

R113

Rotary Disc Header

Unloading and Assembly Instructions

262706 Revision A

Original Instruction

R113 Rotary Disc Header

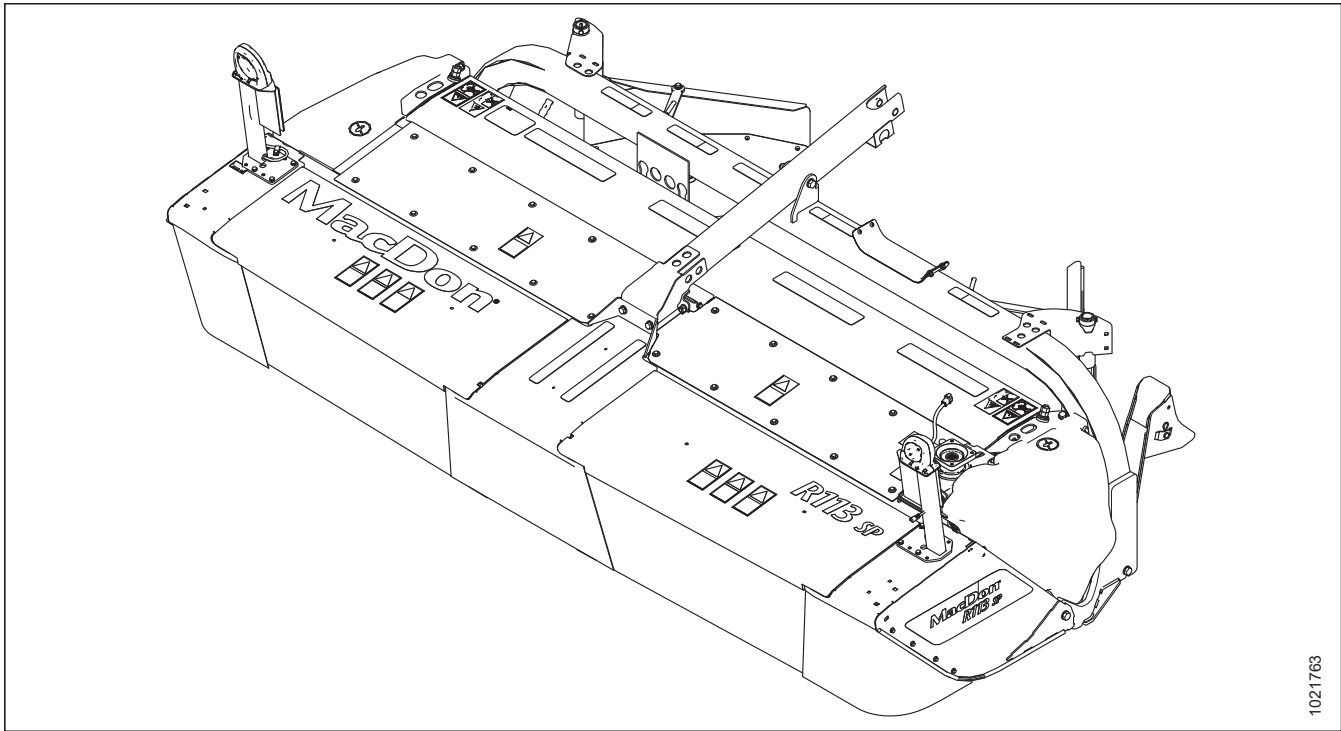

1021763

Published June 2024

© 2024 MacDon Industries, Ltd.

The information in this publication is based on the information available and in effect at the time of printing. MacDon Industries, Ltd. makes no representation or warranty of any kind, whether expressed or implied, with respect to the information in this publication. MacDon Industries, Ltd. reserves the right to make changes at any time without notice.

Introduction

This instruction describes the unloading, setup, and predelivery requirements for the MacDon R113 Rotary Disc Header.

To ensure that the customer receives all of the performance and safety benefits from this product, carefully follow the unloading and assembly procedure from the beginning through to completion.

Retain this instruction for future reference.

Carefully read all the material provided before attempting to unload, assemble, or use the machine.

Conventions

The following conventions are followed in this document:

- Right and left are determined from the operator's position, facing the direction of travel.
- Unless otherwise noted, use the standard torque values provided in this manual. When torque values of 30 Nm or less are listed, their equivalents will be provided in both foot-pounds (lbf·ft) and inch-pounds (lbf·in).

NOTE:

Keep your MacDon publications up-to-date. The most current version can be downloaded from our website (www.macdon.com) or from our Dealer-only site (<https://portal.macdon.com>) (login required).

If the shipment is damaged or is missing parts, contact shortageanddamage@macdon.com.

This instruction is available in English only.

Summary of Changes

At MacDon, we're continuously making improvements, and occasionally these improvements affect product documentation. The following list provides an account of major changes from the previous version of this document.

Section	Summary of Change	Internal Use Only
<i>Throughout manual</i>	Removed discontinued R116 Rotary Disc Header content.	ECN 63134
<i>Introduction, page i</i>	Added contact information for damaged or missing parts in the shipment.	Technical Publications
<i>4.1 Removing Conditioner Drive Belt, page 21</i>	Added topic.	Technical Publications
<i>4.2 Installing Conditioner Drive Belt, page 23</i>	Added topic.	Technical Publications
<i>10.1.15 Checking and Adding Lubricant – Cutterbar, page 125</i>	Added the requirement to warm up the hydraulic oil before checking the oil level.	Technical Publications
<i>10.1.6 Checking and Adding Lubricant – Drive Gearbox, page 121</i>	Added step that applies to new gearboxes or gearboxes that had an oil change.	Engineering
<i>11.4 Torque Specifications, page 133</i>	Removed SAE bolt specifications.	Technical Publications
All tasks listed under <i>Predelivery Checklist, page 144</i>	<ul style="list-style-type: none"> Shortened predelivery procedures. 	Technical Publications Product Support

TABLE OF CONTENTS

Introduction	i
Summary of Changes.....	ii
Chapter 1: Safety	1
1.1 Safety Alert Symbols	1
1.2 Signal Words	2
1.3 General Safety	3
1.4 Hydraulic Safety	5
1.5 Welding Precautions	6
1.6 Safety Signs	7
Chapter 2: Unloading Header.....	9
Chapter 3: Assembling Header.....	11
3.1 Removing Lower Shipping Support	11
3.2 Lowering Header	15
3.3 Removing Shipping Stands	17
3.4 Installing Hydraulic Header Drive.....	18
3.5 Assembling Hazard Lights.....	19
Chapter 4: Changing Conditioner	21
4.1 Removing Conditioner Drive Belt.....	21
4.2 Installing Conditioner Drive Belt	23
4.3 Removing Conditioner	25
4.4 Installing Conditioner	30
4.4.1 Installing Conditioner Drive.....	36
4.5 Discharge Shield – No Conditioner.....	38
4.5.1 Removing Discharge Shield – No Conditioner	38
4.5.2 Installing Discharge Shield – No Conditioner	39
Chapter 5: Attaching Header to Windrower	41
5.1 Attaching Header to M2 Series Windrower	41
5.2 Attaching Header to M1 Series Windrower	48
5.3 Attaching Header to M155, M155E4, or M205 Self-Propelled Windrower – Hydraulic Center-Link with Self-Alignment	55
5.4 Attaching Header – Hydraulic Center-Link without Self-Alignment.....	61
Chapter 6: Attaching Hydraulic and Electrical Components.....	67
6.1 Connecting Header Hydraulic and Electrical Systems – M2170 Windrower.....	67
6.2 Connecting Header Hydraulic and Electrical Systems – M2260 Windrower.....	71
6.2.1 Auger/Rotary Disc/Draper-Ready Configuration – Quick Coupler Connections.....	72
6.2.2 Rotary Disc-Only Configuration – Hard-Plumbed Fittings	75
6.2.3 Rotary Disc-Only Configuration – Quick Coupler Connections.....	77

TABLE OF CONTENTS

6.2.4 Calibrating M2 Series Windrower and Header on HarvestTouch™ Display	80
Calibrating Knife Drive on HarvestTouch™ Display – M2 Series Windrowers.....	80
Calibrating Header Position Sensors on HarvestTouch™ Display	84
6.3 Connecting Header Hydraulic and Electrical Systems – M1240 Windrower.....	88
6.4 Connecting Header Hydraulic and Electrical Systems – M1170 Windrower.....	94
6.4.1 Calibrating M1 Series Windrower Knife Drive and Header on Harvest Performance Tracker Display.....	97
6.5 Connecting Header Hydraulic and Electrical Systems – M155 or M155E4 Windrowers	99
6.6 Connecting Header Hydraulic and Electrical Systems – M205 Windrower	106
Chapter 7: Unpacking Curtains	107
Chapter 8: Installing Options.....	109
8.1 Installing Tall Crop Dividers	109
Chapter 9: Lubricating Rotary Disc Header	111
9.1 Lubrication Locations	112
Chapter 10: Performing Predelivery Checks.....	113
10.1 Performing Predelivery Checks.....	113
10.1.1 Checking and Adjusting Conditioner Drive Belt	114
10.1.2 Checking Skid Shoes.....	114
10.1.3 Checking and Adjusting Forming Shield Deflector Position	115
10.1.4 Checking Header Float	115
Checking Float – M1 Series Windrowers	115
Checking Float – M Series Windrowers	119
10.1.5 Checking and Adding Lubricant – Conditioner Roll Timing Gearbox	121
10.1.6 Checking and Adding Lubricant – Drive Gearbox	121
10.1.7 Checking and Adjusting Roll Gap	122
10.1.8 Checking Roll Timing	123
10.1.9 Checking and Adjusting Roll Tension	123
10.1.10 Adjusting Conditioner Baffle Position	123
10.1.11 Checking Lights	124
10.1.12 Checking Manuals.....	124
10.1.13 Checking Disc Timing Tool	125
10.1.14 Running up Machine	125
10.1.15 Checking and Adding Lubricant – Cutterbar	125
Chapter 11: Reference	127
11.1 Opening Driveshields.....	127
11.2 Closing Driveshields.....	129
11.3 Cutterbar Doors.....	130
11.3.1 Opening Cutterbar Doors.....	130
11.3.2 Opening Cutterbar Doors – Export.....	131
11.3.3 Closing Cutterbar Doors.....	132
11.4 Torque Specifications	133

TABLE OF CONTENTS

11.4.1 Metric Bolt Specifications 133

11.4.2 Metric Bolt Specifications – Cast Aluminum 135

11.4.3 O-Ring Boss Hydraulic Fittings – Adjustable..... 136

11.4.4 O-Ring Boss Hydraulic Fittings – Non-Adjustable 137

11.4.5 O-Ring Face Seal Hydraulic Fittings 138

11.4.6 Tapered Pipe Thread Fittings 139

11.5 Conversion Chart 141

11.6 Definitions 142

Predelivery Checklist 144

Recommended Lubricants 147

Chapter 1: Safety

Understanding and consistently following these safety procedures will help to ensure the safety of those operating the machine and of bystanders.

1.1 Safety Alert Symbols

The safety alert symbol indicates important safety messages in this manual and on safety signs on the machine.

This symbol means:

- **ATTENTION!**
- **BECOME ALERT!**
- **YOUR SAFETY IS INVOLVED!**

Carefully read and follow the safety message accompanying this symbol.

Why is safety important to you?

- Accidents disable and kill
- Accidents cost
- Accidents can be avoided



Figure 1.1: Safety Symbol

1.2 Signal Words

Three signal words, **DANGER**, **WARNING**, and **CAUTION**, are used to alert you to hazardous situations. Two signal words, **IMPORTANT** and **NOTE**, identify non-safety related information.

Signal words are selected using the following guidelines:

DANGER

Indicates an imminently hazardous situation that, if it is not prevented, will result in death or serious injury.

WARNING

Indicates a potentially hazardous situation that, if it is not prevented, could result in death or serious injury. It may also be used to alert you to unsafe practices.

CAUTION

Indicates a potentially hazardous situation that, if it is not prevented, may result in minor or moderate injury. It may also be used to alert you to unsafe practices.

IMPORTANT:

Indicates a situation that, if not prevented, could result in a malfunction or damage to the machine.

NOTE:

Provides additional information or advice.

1.3 General Safety

Operating, servicing, and assembling machinery presents several safety risks. These risks can be reduced or eliminated by following the relevant safety procedures and wearing the appropriate personal protective equipment.

CAUTION

The following general farm safety precautions should be part of your operating procedure for all types of machinery.

Wear all protective clothing and personal safety devices that could be necessary for the job at hand. Do **NOT** take chances. You may need the following:

- Hard hat
- Protective footwear with slip-resistant soles
- Protective glasses or goggles
- Heavy gloves
- Wet weather gear
- Respirator or filter mask

In addition, take the following precautions:

- Be aware that exposure to loud noises can cause hearing impairment. Wear suitable hearing protection devices such as earmuffs or earplugs to help protect against loud noises.



Figure 1.2: Safety Equipment



Figure 1.3: Safety Equipment

- Provide a first aid kit in case of emergencies.
- Keep a properly maintained fire extinguisher on the machine. Familiarize yourself with its use.
- Keep young children away from machinery at all times.
- Be aware that accidents often happen when Operators are fatigued or in a hurry. Take time to consider the safest way to accomplish a task. **NEVER** ignore the signs of fatigue.

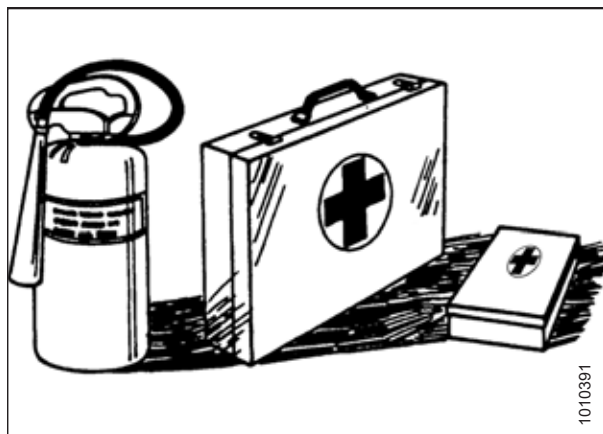

Figure 1.4: Safety Equipment

SAFETY

- Wear close-fitting clothing and cover long hair. **NEVER** wear dangling items such as hoodies, scarves, or bracelets.
- Keep all shields in place. **NEVER** alter or remove safety equipment. Ensure that the driveline guards can rotate independently of their shaft, and that they can telescope freely.
- Use only service and repair parts made or approved by the equipment manufacturer. Parts from other manufacturers may not meet the correct strength, design, or safety requirements.



Figure 1.5: Safety around Equipment

- Keep hands, feet, clothing, and hair away from moving parts. **NEVER** attempt to clear obstructions or objects from a machine while the engine is running.
- Do **NOT** modify the machine. Unauthorized modifications may impair the functionality and/or safety of the machine. It may also shorten the machine's service life.
- To avoid injury or death from the unexpected startup of the machine, **ALWAYS** stop the engine and remove the key from the ignition before leaving the operator's seat for any reason.

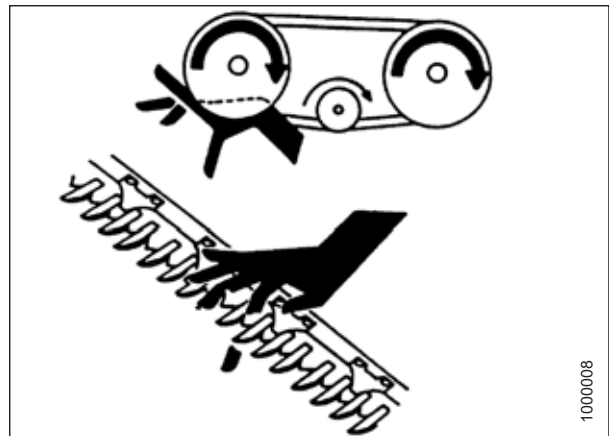

Figure 1.6: Safety around Equipment

- Keep the machine service area clean and dry. Wet and/or oily floors are slippery. Wet spots can be dangerous when working with electrical equipment. Ensure that all electrical outlets and tools are properly grounded.
- Keep the work area well-lit.
- Keep machinery clean. Straw and chaff on a hot engine are fire hazards. Do **NOT** allow oil or grease to accumulate on service platforms, ladders, or controls. Clean machines before they are stored.
- **NEVER** use gasoline, naphtha, or any volatile material for cleaning purposes. These materials may be toxic and/or flammable.
- When storing machinery, cover any sharp or extending components to prevent injury from accidental contact.



Figure 1.7: Safety around Equipment

1.4 Hydraulic Safety

Because hydraulic fluid is under extreme pressure, hydraulic fluid leaks can be very dangerous. Follow the proper safety procedures when inspecting hydraulic fluid leaks and servicing hydraulic equipment.

- Always place all hydraulic controls in **NEUTRAL** before leaving the operator's seat.
- Ensure that all of the components in the hydraulic system are kept clean and in good condition.
- Replace any worn, cut, abraded, flattened, or crimped hoses and steel lines.
- Do **NOT** attempt any makeshift repairs to hydraulic lines, fittings, or hoses by using tapes, clamps, cements, or welding. The hydraulic system operates under extremely high pressure. Makeshift repairs can fail suddenly and create hazardous conditions.



Figure 1.8: Testing for Hydraulic Leaks

- Wear proper hand and eye protection when searching for high-pressure hydraulic fluid leaks. Use a piece of cardboard as a backstop instead of your hands to isolate and identify a leak.
- If you are injured by a concentrated, high-pressure stream of hydraulic fluid, seek medical attention immediately. Serious infection or a toxic reaction can develop from hydraulic fluid piercing the skin.



Figure 1.9: Hydraulic Pressure Hazard

- Ensure that all components are tight and that steel lines, hoses, and couplings are in good condition before applying pressure to a hydraulic system.

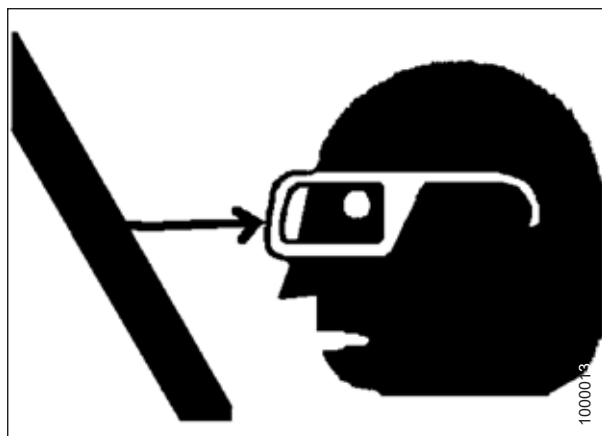

Figure 1.10: Safety around Equipment

1.5 Welding Precautions

To prevent damage to sensitive electronics, **NEVER** attempt welding on the header while it is connected to a windrower.



WARNING

NEVER attempt welding on the header while it is connected to a windrower. Severe damage to sensitive, expensive electronics can result from welding on the header while it is connected to a windrower. It can be impossible to know what effect a high current may have regarding future malfunctions or a shorter lifespan.

For further welding precautions, consult the windrower operator's manual.

1.6 Safety Signs

Safety signs are decals placed on the machine where there is a risk of personal injury, or where the Operator should take extra precautions before operating the controls. They are usually yellow.

- Keep safety signs clean and legible at all times.
- Replace safety signs that are missing or illegible.
- If the original part on which a safety sign was installed is replaced, ensure that the repair part displays the current safety sign.

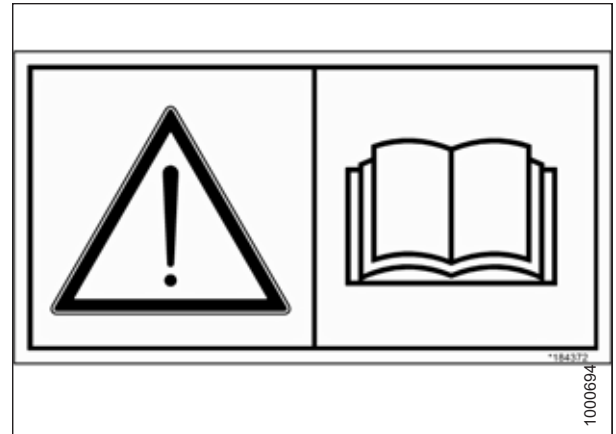

Figure 1.11: Operator's Manual Decal

Chapter 2: Unloading Header

To unload the header from the trailer safely and without damage, understand the weights and lifting requirements and familiarize yourself with the procedure.

WARNING

Be sure the forks are secure before moving away from load. Stand clear when lifting.

CAUTION

To avoid injury to bystanders from being struck by machinery, do **NOT** allow people to stand in unloading area.

CAUTION

Equipment used for unloading must meet or exceed the requirements specified below. Using inadequate equipment may result in chain breakage, vehicle tipping, or machine damage.

Table 2.1 Lifting Vehicle

Minimum Capacity ¹	3630 kg (8000 lb.)
Minimum Fork Length	198 cm (78 in.)

IMPORTANT:

Forklifts are normally rated for a load located 610 mm (24 in.) ahead of the back end of the forks. To obtain the forklift capacity at 1220 mm (48 in.), check with your forklift distributor.

IMPORTANT:

Do **NOT** lift at hooks (A) when unloading from the trailer. Hooks (A) are **ONLY** for tipping the machine over to working position.

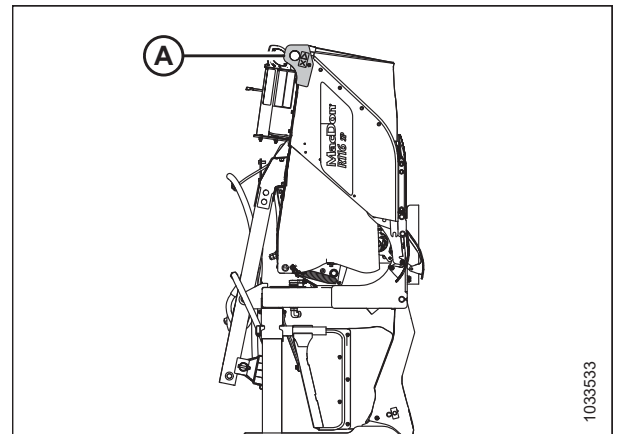

Figure 2.1: Lifting Header off Trailer

1. At 1220 mm (48 in.) from the back end of the forks.

UNLOADING HEADER

1. Remove the hauler's tie-down straps and chains.
2. Approach the header from its underside and slide the forks under the lifting framework as far as possible.

IMPORTANT:

Do **NOT** damage the hydraulic hoses hanging below the header.

3. Raise the header off the deck.

IMPORTANT:

Headers are often shipped two per trailer. If unloading a header from a two-unit load, avoid damaging the other header.

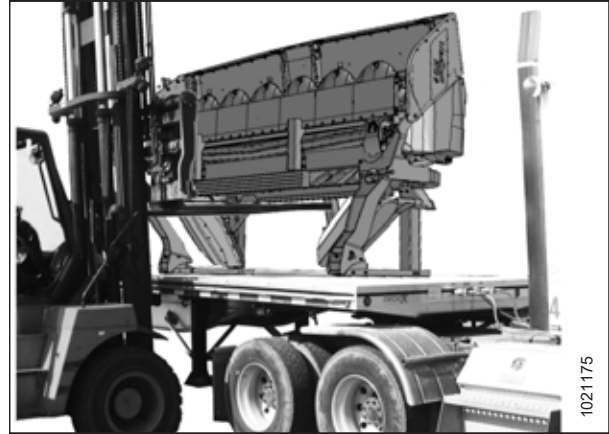

Figure 2.2: Lifting Header off Trailer

4. Back up until the header clears the trailer, and then slowly lower the header to 150 mm (6 in.) from the ground.
5. Take the header to the storage or setup area.
6. Set the header down on secure, level ground.
7. Check for shipping damage and missing parts.

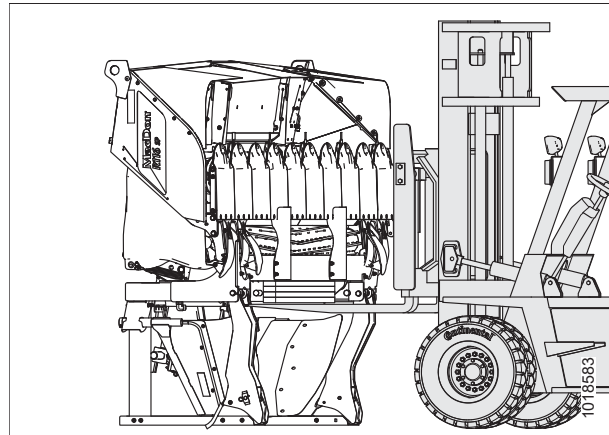

Figure 2.3: Moving Header with Forklift

Chapter 3: Assembling Header

Perform the procedures in the order in which they are presented.

3.1 Removing Lower Shipping Support

The skid shoes on both sides of the header must be lifted out of the way to remove the base support.

1. Support wood brace (B), cut three shipping straps (A), and then remove the wood brace.

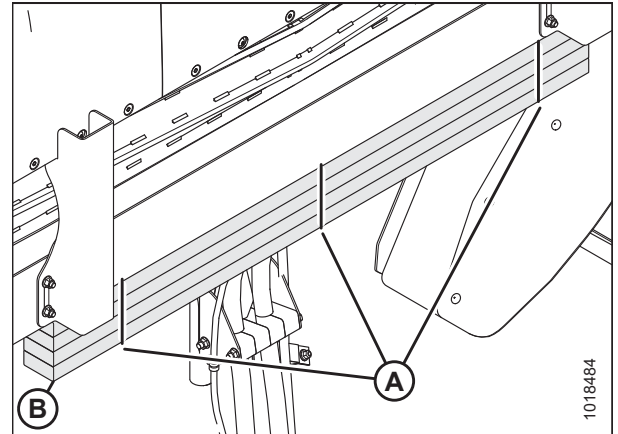

Figure 3.1: Shipping Support

2. Remove four bolts (A) on both vertical fork channels (B), and then remove the vertical fork channels.

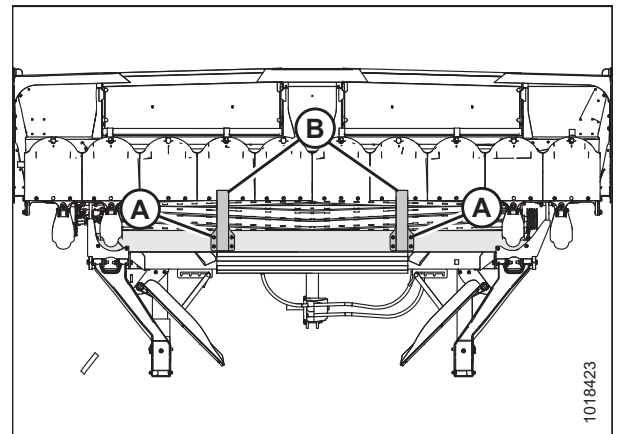

Figure 3.2: Vertical Fork Channels

ASSEMBLING HEADER

3. Remove bolt (A) from skid shoe (B). Retain the bolt for reinstallation.

NOTE:

R113 SP headers have one skid shoe per side.

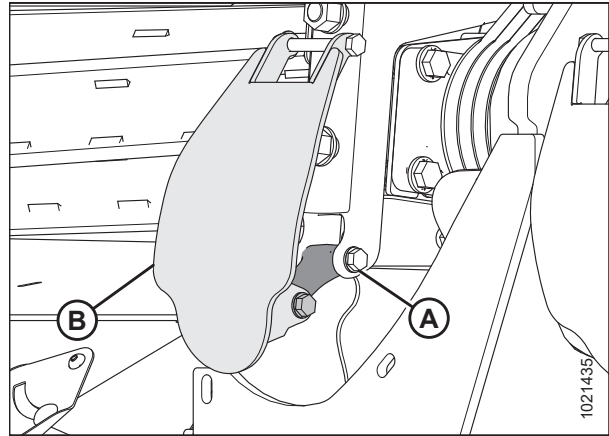

Figure 3.3: Left Skid Shoe Shown

4. Lift skid shoe (B) out of the way and support it with wire (A). Repeat these steps on the opposite skid shoe.

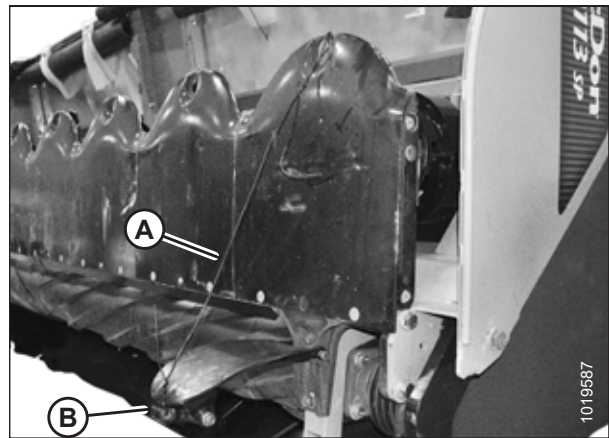

Figure 3.4: Left Skid Shoe Shown

ASSEMBLING HEADER

5. Remove three bolts (A) from each side of base support (B).

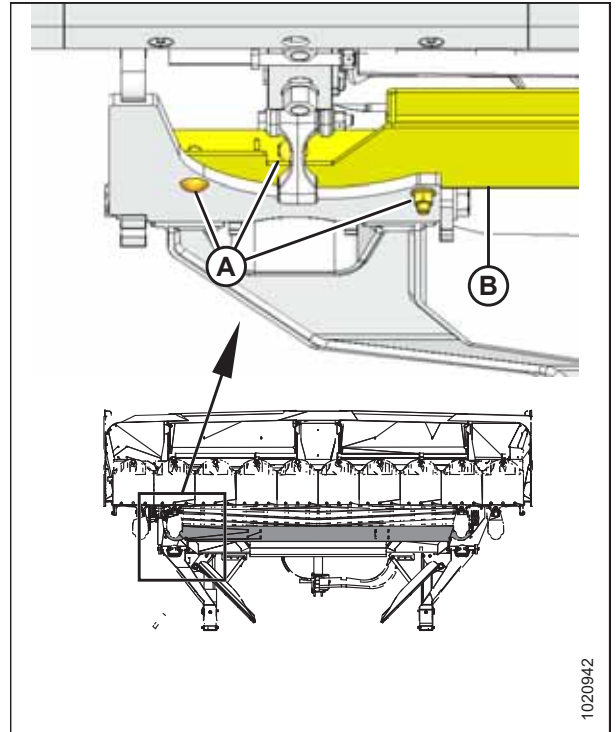

Figure 3.5: Base Shipping Support – Right Side Shown

6. Remove base support (A).

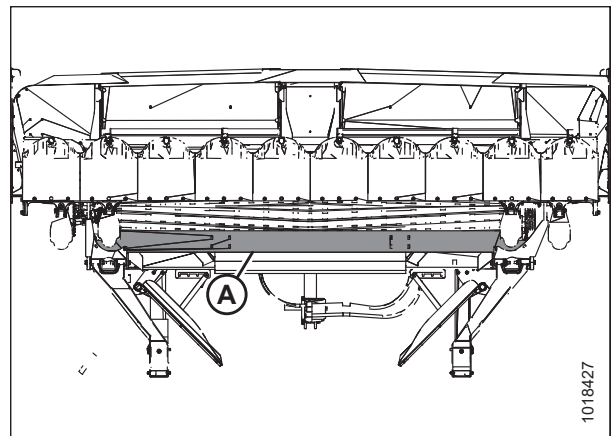

Figure 3.6: Base Shipping Support

ASSEMBLING HEADER

7. Remove wire (A) holding skid shoe (B).

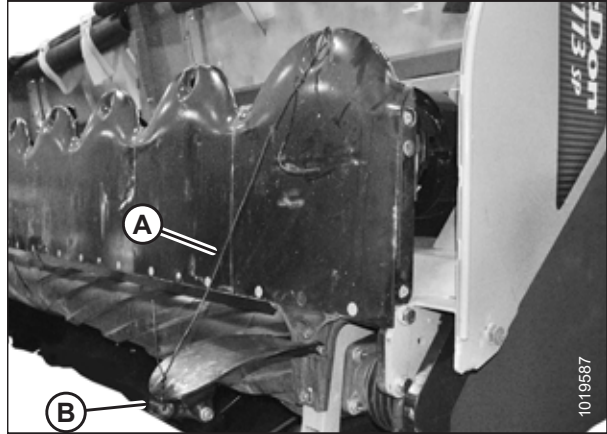

Figure 3.7: Left Skid Shoe Shown

8. Tilt skid shoe (B) inward, and align link (A) with the mounting hole in the skid shoe.
9. Install bolt, washer, and nut (C).
10. Push the skid shoe towards the header, and tighten nut (C).
11. Repeat Steps 7, page 14 to 10, page 14 on the second skid shoe.

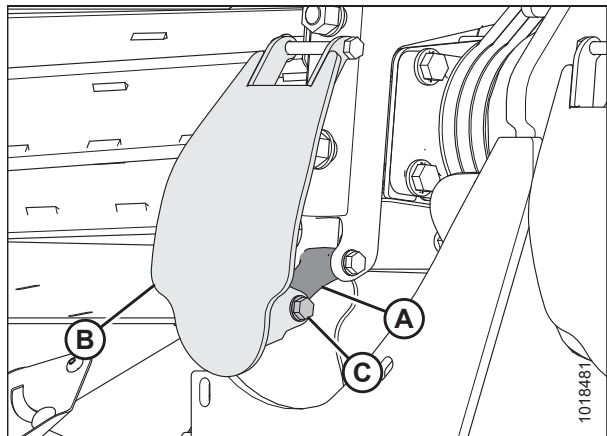

Figure 3.8: Left Skid Shoe Shown

3.2 Lowering Header

Complete the following steps to lower the header into field position after it has been lifted off of its shipping trailer and set down on the ground.

⚠ DANGER

Ensure that a spreader bar is secured to the forks so that it cannot slide off the forks or toward the mast as you lower the header to the ground.

Table 3.1 Lifting Vehicle

Chain Type	Overhead lifting quality, 13 mm (1/2 in.)
Minimum Working Load	2270 kg (5000 lb.)

1. Attach spreader bar (A) to forks.

IMPORTANT:

Length of spreader bar must be approximately 4600 mm (180 in.).

2. Approach the underside of the header with the lifting vehicle.
3. Attach chains to hooks (B) on either side of the header.

IMPORTANT:

Do **NOT** lift at the hooks when unloading the header from the trailer. This procedure is only for laying the machine over into field position.

IMPORTANT:

The chain length must be sufficient to provide a minimum of 1220 mm (48 in.) (C) between the spreader bar and the header.

4. Raise the forks until the lift chains are fully tensioned.

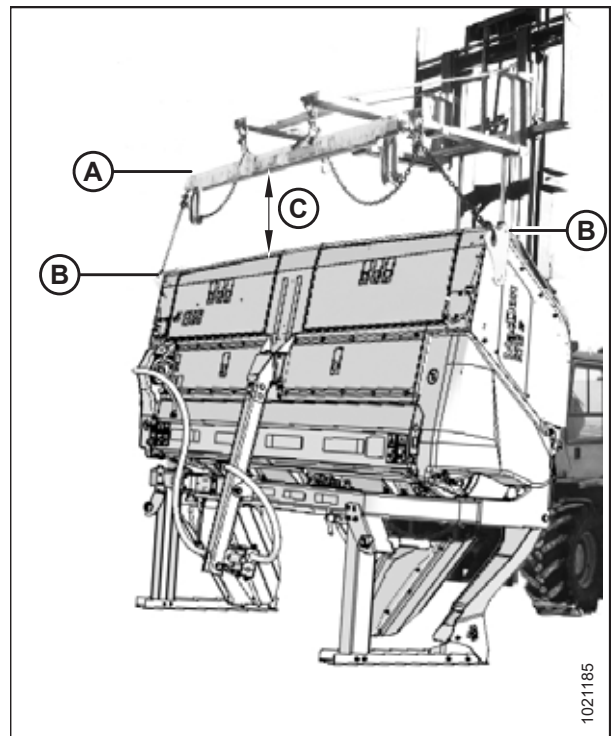

Figure 3.9: Spreader Bar Attached to Header

ASSEMBLING HEADER

DANGER

Stand clear when lowering the rotary disc header.

5. Back up **SLOWLY**, while simultaneously lowering the header until the cutterbar rests on the ground.
6. Remove chains from the header.

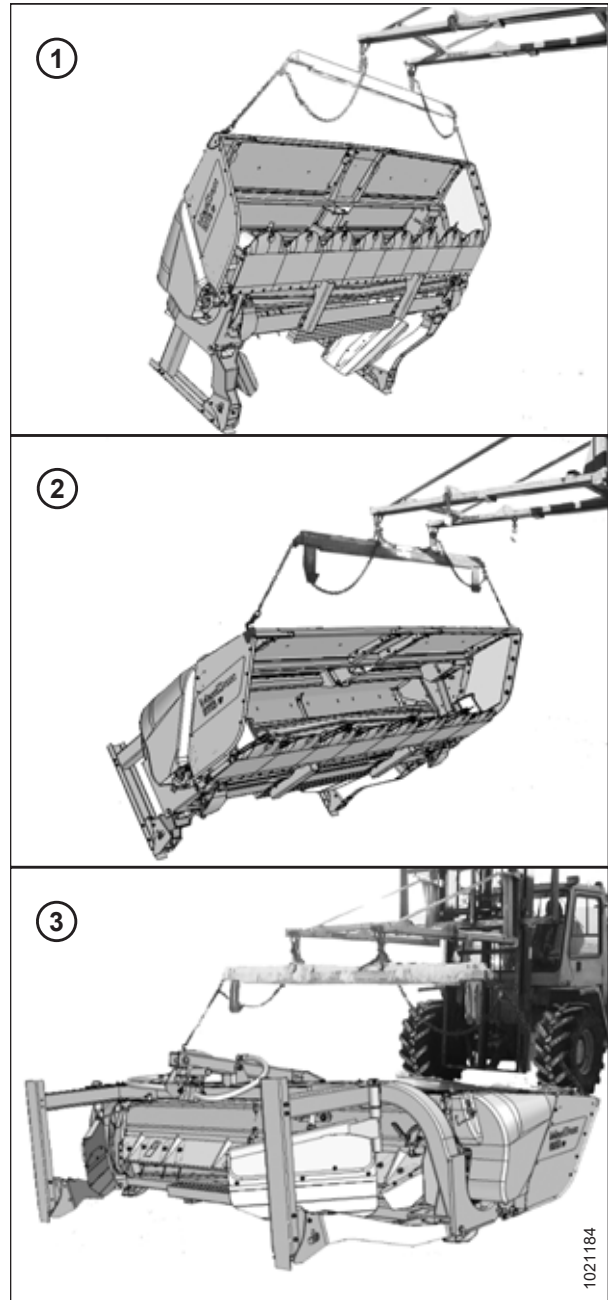

Figure 3.10: Lowering Header to the Ground

3.3 Removing Shipping Stands

The shipping stand and other supports must be removed from the header prior to assembly.

NOTE:

This procedure must be completed on both sides of the header near the forming shields.

1. Remove four bolts (A).
2. Remove bolt (B).

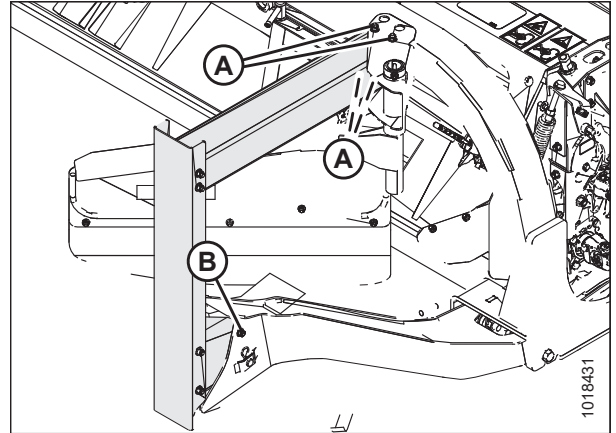

Figure 3.11: Shipping Stands – Right Side Shown, Left Side Opposite

3. Remove shipping wires from header lift boots (D).
4. Remove hair pin (A) from clevis pin (B).
5. Hold shipping stand (C) and remove clevis pin (B).
6. Remove stand (C) and discard. Reinsert pin (B) in header lift boot and secure with hair pin (A).

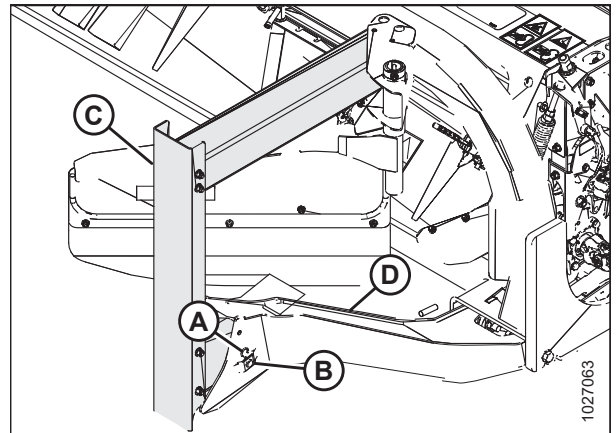

Figure 3.12: Shipping Stands – Right Side Shown

7. Remove shipping hooks (A) from front corners and reinstall hardware.

NOTE:

If installing tall crop divider option, do **NOT** reinstall hardware.

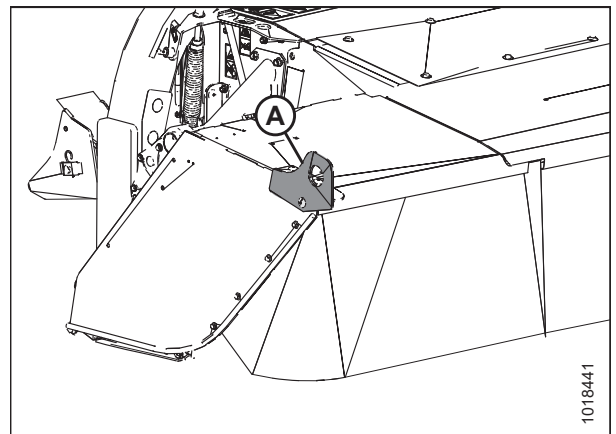

Figure 3.13: Shipping Hook

3.4 Installing Hydraulic Header Drive

The R113 Rotary Disc Headers are assembled without a hydraulic header drive. The compatible hydraulic header drive kit must be installed at this stage of the assembly.

1. Use the instructions supplied with the kit to install the compatible hydraulic header drive kit.

Table 3.2 Hydraulic Drive Kit Compatibility

Windrower	Hydraulic Drive Kit (includes installation instructions)
M2170 and M1170	B6845
M155 and M155E4	B6272
M2260 and M1240	B6845 and B6698
M205	B6845 and MD #257188

3.5 Assembling Hazard Lights

Detach the hazard light bracket from the shipping bracket, and install onto the frame.

1. Detach hazard light bracket (A) from shipping bracket (B) by removing four bolts (C), washers (D), and nuts (E). Retain the hardware for installation.

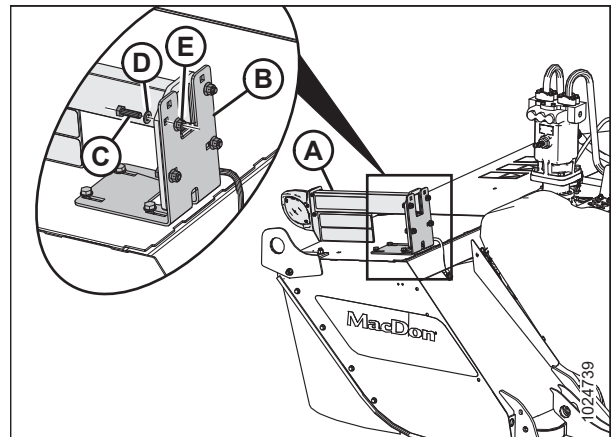

Figure 3.14: Hazard Light Shipping Bracket – Right Side

2. Detach shipping bracket (A) from the header by removing four bolts (B), washers (C), and nuts (D). Discard the hardware.

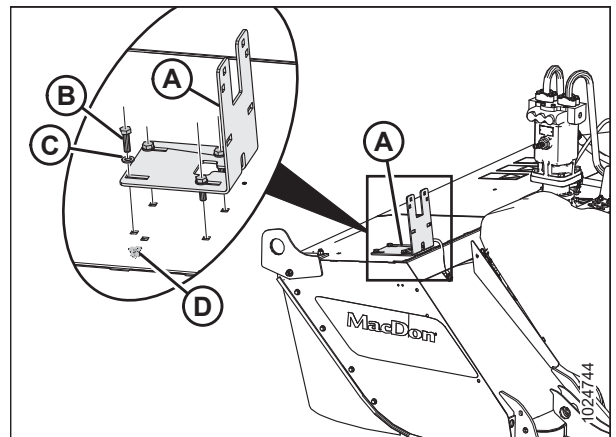

Figure 3.15: Hazard Light Shipping Bracket – Right Side

3. Install hazard light bracket (A) with hardware retained from Step 1, page 19. Install four bolts (B) and washers (C) from above, and secure with nuts (D) from below the frame.
4. Repeat all the steps on the opposite side of the machine.

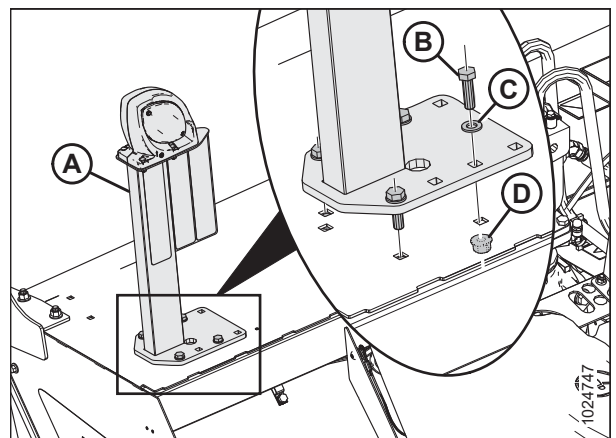

Figure 3.16: Hazard Light Bracket – Right Side

Chapter 4: Changing Conditioner

There are several ways that the conditioner can be configured, depending on your particular machine.

If a conditioner change is **NOT** required, proceed to [5 Attaching Header to Windrower, page 41](#).

The R1 Series Rotary Disc Header can be operated either with no conditioner, with a polyurethane roll conditioner, or with a steel roll conditioner. If the rotary disc header is not conditioner-equipped, a shield must be installed.

NOTE:

These instructions apply to all conditioners. Exceptions are identified where applicable.

If the header was shipped with the desired conditioner configuration, proceed to [5 Attaching Header to Windrower, page 41](#).

If the header was shipped without a conditioner, and you want to install one, proceed to [4.4 Installing Conditioner, page 30](#).

4.1 Removing Conditioner Drive Belt

Remove the conditioner drive belt if it is torn or cracked.

DANGER

To prevent bodily injury or death from the unexpected startup of the machine, always stop the engine and remove the key from the ignition before leaving the operator's seat.

1. Lower the header fully.
2. Shut down the engine, and remove key from the ignition.
3. Open the left driveshield. For instructions, refer to [11.1 Opening Driveshields, page 127](#).
4. Disconnect wire harness (A) from speed sensor (B).

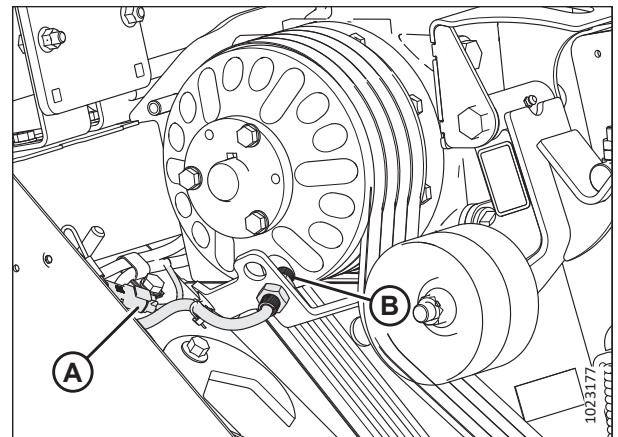

Figure 4.1: Speed Sensor Assembly

CHANGING CONDITIONER

5. Turn jam nut (A) counterclockwise to unlock the tension adjustment.
6. Turn jam nut (A) and adjuster nut (B) counterclockwise to fully collapse tensioner spring (C), and release the tension from conditioner drive belt (D).
7. Remove drive belt (D).

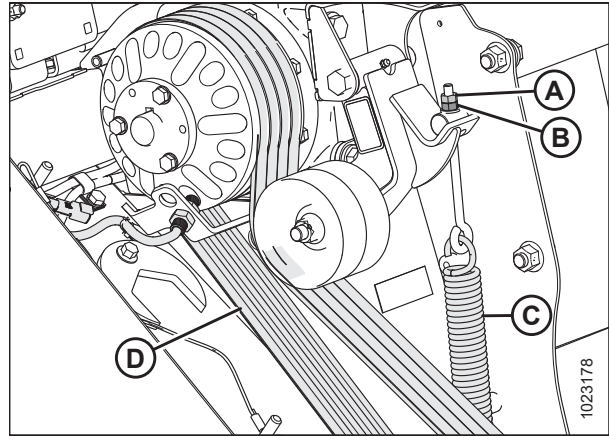

Figure 4.2: Conditioner Drive

4.2 Installing Conditioner Drive Belt

Ensure that the length of the tensioner spring is set correctly when installing the conditioner drive belt.

DANGER

To prevent bodily injury or death from the unexpected startup of the machine, always stop the engine and remove the key from the ignition before leaving the operator's seat.

1. Lower the header fully.
2. Shut down the engine, and remove the key from the ignition.
3. Install drive belt (A) onto driven pulley (C) first, and then onto drive pulley (B), ensuring that the belt is in the pulley grooves.

NOTE:

If necessary, loosen the jam nut and adjuster nut to relieve the spring tension.

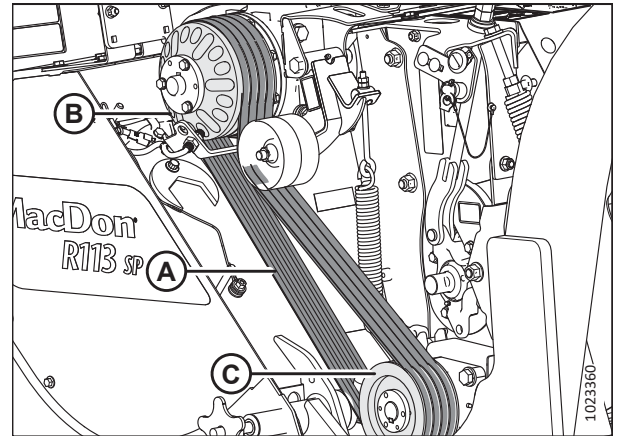

Figure 4.3: Conditioner Drive

4. Measure the length of tensioner spring (C). Dimension (D) should be set to 365 mm (14 3/8 in.) to ensure that the belt is tensioned correctly.
5. To adjust the spring tension, loosen jam nut (A).
6. Turn adjuster nut (B) clockwise to increase the belt tension, or turn adjuster nut (B) counterclockwise to decrease the belt tension.
7. Once the correct spring measurement has been achieved, hold adjuster nut (B) and tighten jam nut (A) against it.

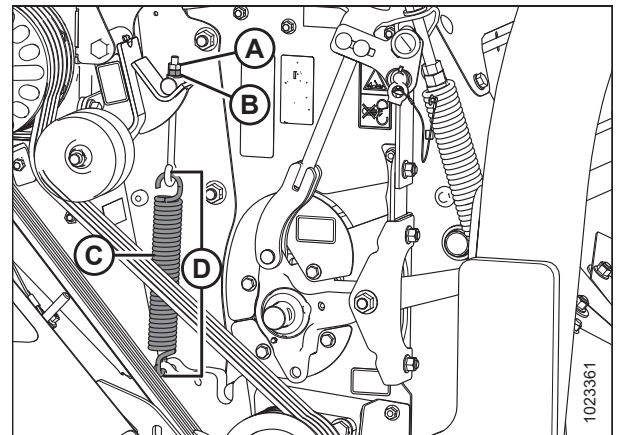

Figure 4.4: Conditioner Drive

CHANGING CONDITIONER

8. Reconnect speed sensor (B) to wiring harness (A).

NOTE:

Use the bottom hole for M1 Series and M2 Series Windrowers; use the top hole for M Series Windrowers.

9. Close the left driveshield. For instructions, refer to [11.2 Closing Driveshields, page 129](#).

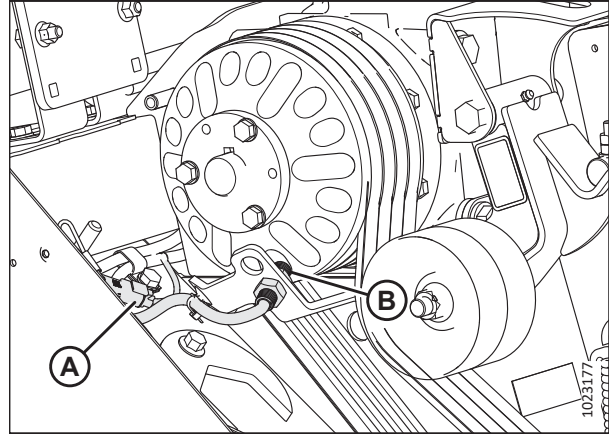

Figure 4.5: Speed Sensor

4.3 Removing Conditioner

The conditioner is very heavy. Removing the conditioner requires a forklift or an equivalent lifting device.

1. Open the driveshields. For instructions, refer to [11.1 Opening Driveshields, page 127](#).
2. Disconnect wire harness (A) from speed sensor (B).

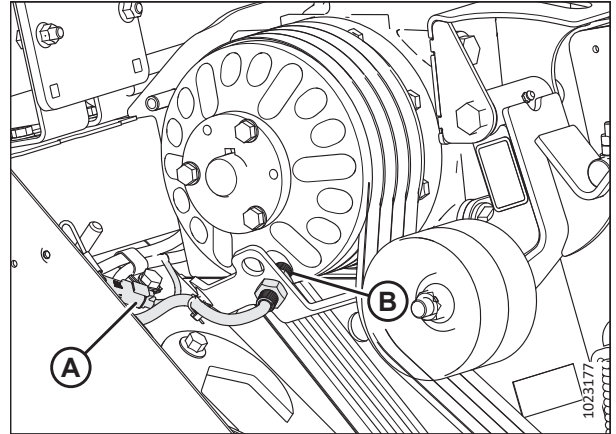

Figure 4.6: Speed Sensor Assembly

3. Turn jam nut (A) counterclockwise to unlock the tension adjustment.
4. Turn jam nut (A) and adjuster nut (B) counterclockwise to fully collapse tensioner spring (C), and release the tension from conditioner drive belt (D).
5. Remove drive belt (D).

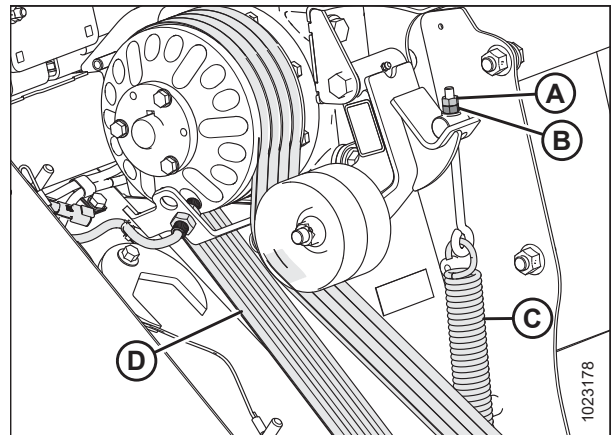

Figure 4.7: Conditioner Drive

6. **M1/M2 Series and M205 Windrowers:** Move hose bundle (A) clear of the frame and lay it on the header.

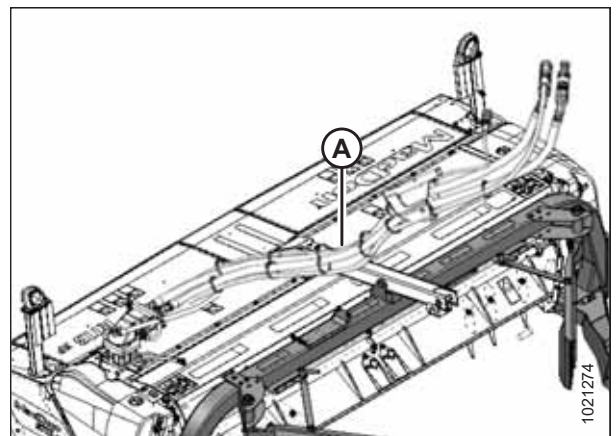

Figure 4.8: Windrower Hose Bundle

CHANGING CONDITIONER

7. **M155 and M155E4 Windrowers:** Remove two bolts (A) securing hose bracket (B) to the header frame.
8. Place the hose bundle and the bracket onto the header.

NOTE:

Do **NOT** disconnect the hoses from the motor.

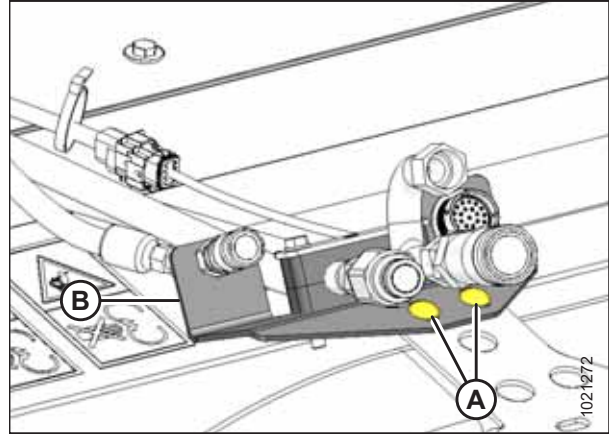

Figure 4.9: M155 and M155E4 Hose Support

WARNING

To prevent the frame from slipping off of the forks, ensure that the frame is secured to the forks. Failing to secure the frame to the forks could result in death or serious injury.

9. Support and secure the adapter frame for lifting. Use one of the two methods below:

Method 1:

- a. Attach straps (A) to adapter frame (B) and to the forklift forks. Straps with a minimum working load of 454 kg (1000 lb.) should be used.

NOTE:

The forks should **NOT** directly contact the frame.

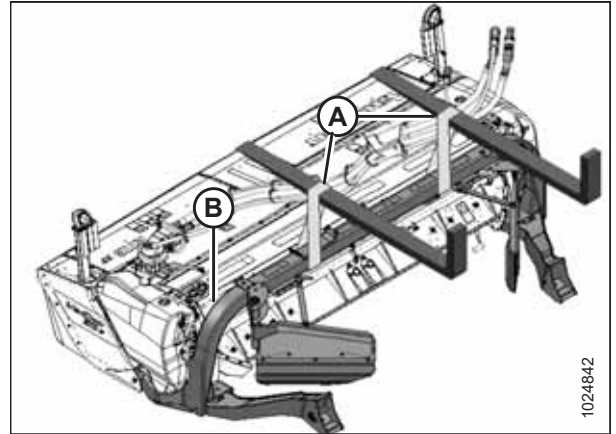

Figure 4.10: Supporting Frame Using Straps

Method 2:

- a. To protect the finish on the frame, wrap packing foam (A) (or equivalent) around the frame at approximately the locations shown.
- b. Position forks (B) under the packing foam on the frame as shown. Raise the forks and lift the frame slightly.

NOTE:

The forks should **NOT** directly contact the frame.

- c. To secure the frame to the forks, wrap chain (C) around the end of the forks and attach the other end of the chain to the forklift.

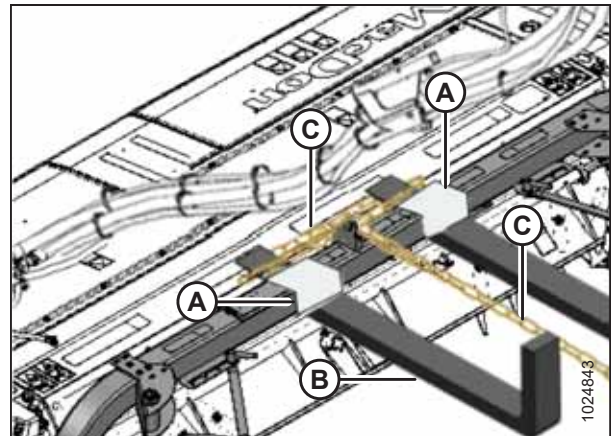

Figure 4.11: Supporting Frame Using Chain

10. Lift the header with the forklift and place 150 mm (6 in.) wooden blocks (A) under the skid shoes. Lower the header onto the blocks and allow the header to tilt forward.

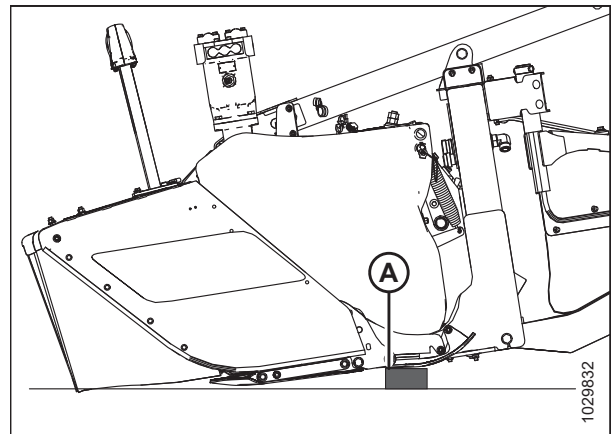

Figure 4.12: Header on Blocks

CHANGING CONDITIONER

11. Remove nut (A) securing bolt (B), washer (C), and washer shims (D) from the center-link support. If necessary, adjust the height of the forks lifting the frame. Retain the hardware for reinstallation.

NOTE:

Some sections are made hidden in the illustration to help clarify the position of shims (D).

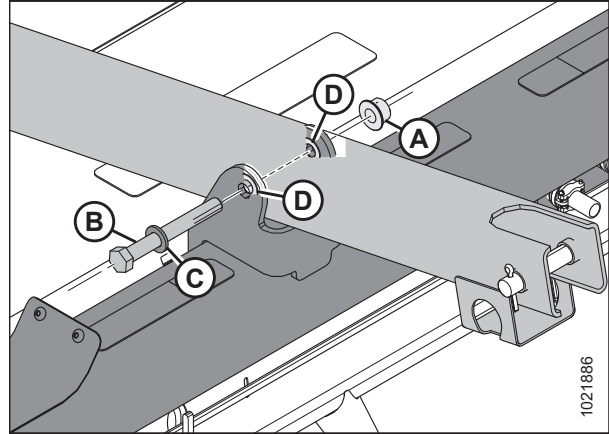

Figure 4.13: Center-Link Support

CAUTION

Stand clear when the frame is being detached, because the frame may shift when the bolts are removed.

12. Remove nut (B).
13. Remove bolt (A) from frame (C). If necessary, adjust the height of the forks to improve access to bolt (A). Repeat this step at the opposite side of the frame. Retain the hardware for reinstallation.
14. Slowly and carefully back the forklift away from the header until the frame is clear of the header. Move the frame away from the work area, lower it to the ground, and disconnect it from the forklift.

WARNING

To prevent the conditioner from falling backward, ensure that the lifting chains are secure. Failure to do so may result in death or serious injury.

15. Attach spreader bar (A) to a forklift or equivalent lifting device, and attach chains to lugs (B) on conditioner (C). Use a chain rated for overhead lifting with a minimum working load of 1135 kg (2500 lb.).

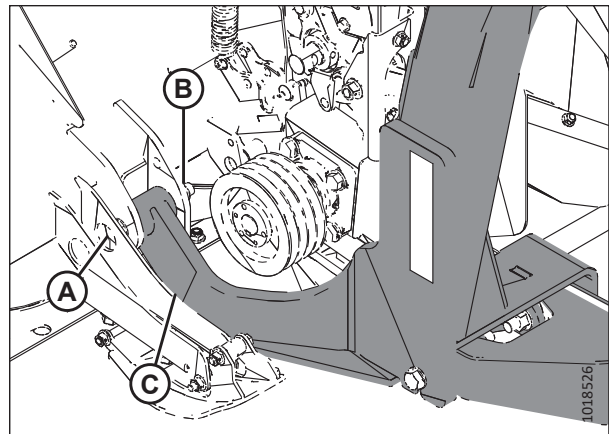

Figure 4.14: Left Side of Adapter Frame

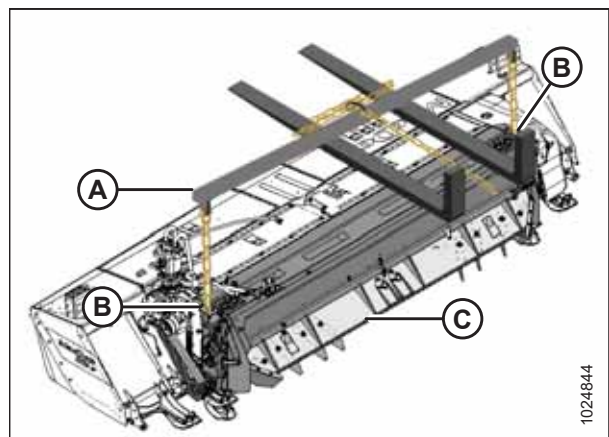

Figure 4.15: Spreader Bar

CHANGING CONDITIONER

16. Loosen two M16 hex head bolts (A) on each side of the conditioner.

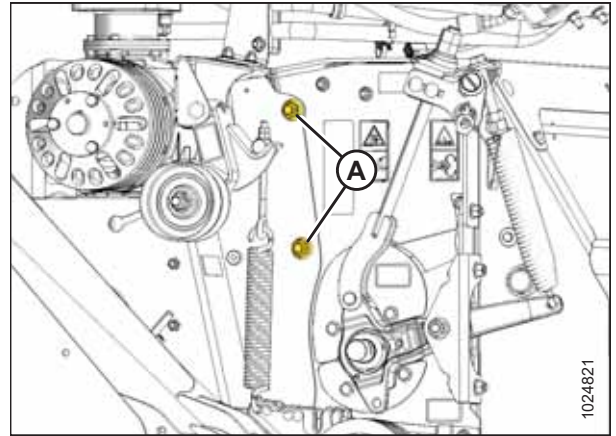

Figure 4.16: Left Side of Conditioner – Right Side Similar

17. Loosen two carriage bolts (A) securing conditioner gearbox support (B) to the header.
18. Adjust the height of the forks to raise the conditioner slightly. Remove the loosened bolts and retain the hardware for reinstallation.

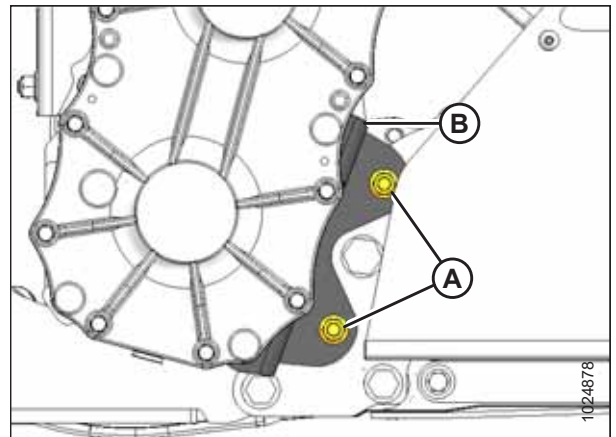

Figure 4.17: Conditioner Gearbox

WARNING

Ensure that the spreader bar is secured to the forks so that it cannot slide off the forks or toward the header. Failing to do so could result in death or serious injury.

19. Using the forklift, lift conditioner (A) off of header (B). Avoid contact between the top of the conditioner and center-link anchor (C).
20. Move the frame away from the work area, set it on the ground, and remove the chains securing the conditioner to the spreader bar.

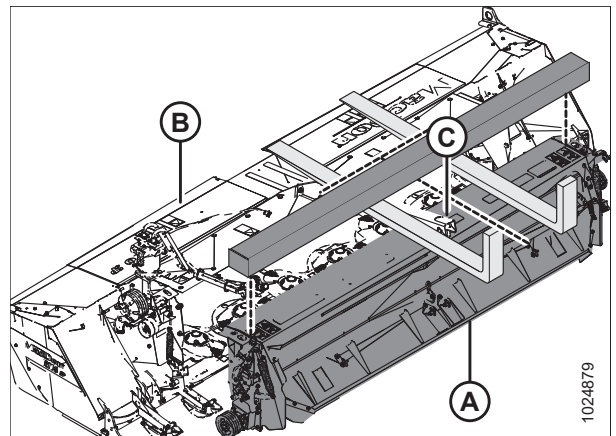

Figure 4.18: Lifting Conditioner

4.4 Installing Conditioner

The conditioner is very heavy. Installing it will require a forklift or an equivalent lifting device.

1. Attach spreader bar (A) to the forklift (or an equivalent lifting device) and attach chains to lugs (B) on the conditioner. Use a chain rated for overhead lifting with a minimum working load of 1135 kg (2500 lb.).

WARNING

Ensure that the spreader bar is secured to the forks so that it cannot slide off the forks or toward the header while you are attaching the conditioner to the header. Failing to do so could result in death or serious injury.

2. Lift conditioner (C) and align it with the header opening.

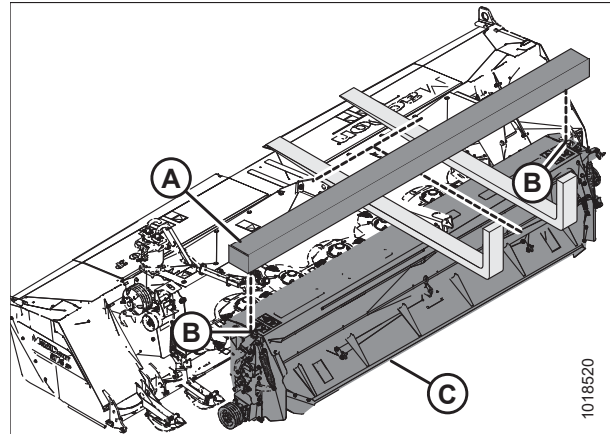

Figure 4.19: Lifting Conditioner

3. Carefully align pin (B) at each end of conditioner (A) with lug (C) on the header.
4. Lower conditioner (A) until pins (B) engage lugs (C) on the header.

NOTE:

Avoid contact between the top of the conditioner and the center-link anchor.

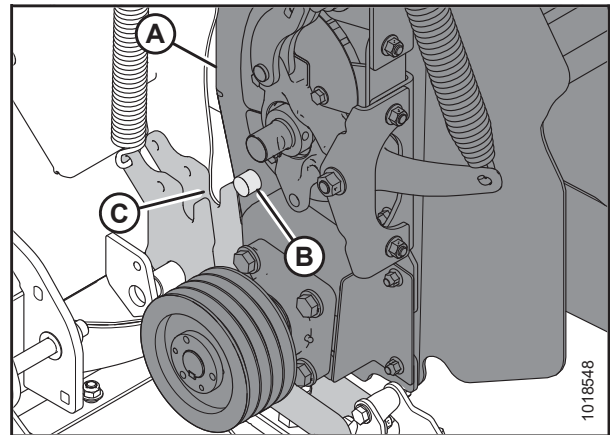

Figure 4.20: Installing Conditioner

5. Align the mounting holes and install four M16 x 40 hex head bolts (A) with the heads facing inboard (two per side).
6. Secure the bolts with four M16 center lock flanged nuts.

NOTE:

Do **NOT** tighten the nuts yet.

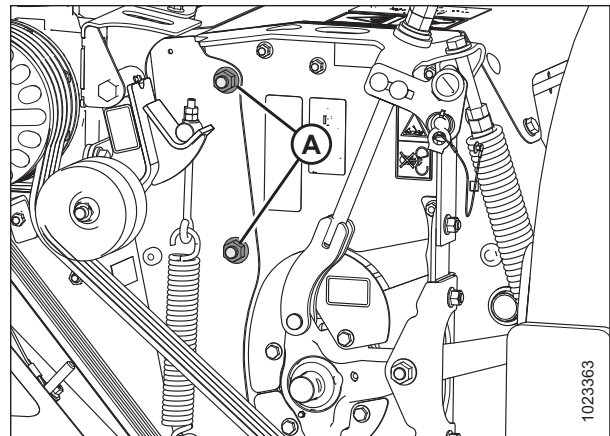

Figure 4.21: Left Side of Conditioner – Right Side Similar

CHANGING CONDITIONER

- Align the holes in support (B) with the mounting holes in the header frame.
- Install two carriage bolts (A) to secure conditioner gearbox support (B) to the header.

NOTE:

The bolt heads must face inboard.

- Torque the nuts to 69 Nm (51 lbf-ft).

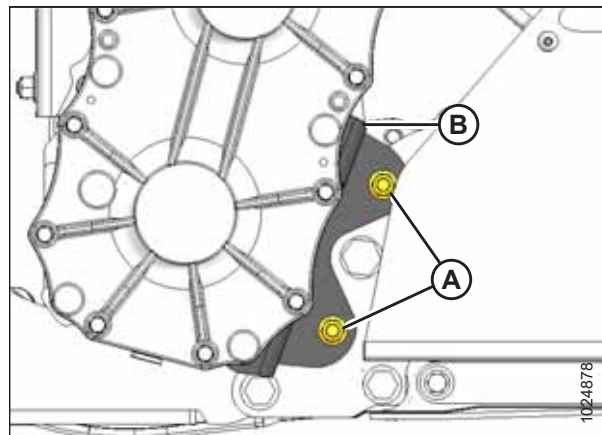

Figure 4.22: Conditioner Gearbox

- Torque nuts (A) on the sides of the conditioner to 170 Nm (126 lbf-ft).
- Remove the lifting chains from the conditioner and move the lifting device clear of the work area.
- If the header was originally shipped without a conditioner, install the conditioner drive components. For instructions, refer to [4.4.1 Installing Conditioner Drive, page 36](#).

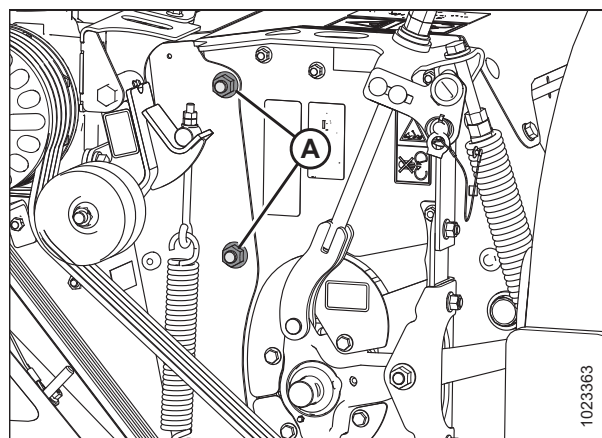

Figure 4.23: Left Side of Conditioner – Right Side Similar

WARNING

To prevent the frame from slipping off of the forks, ensure that the frame is secured to the forks. Failure to do so could result in death or serious injury.

13. Support and secure the adapter frame for lifting. Use one of the two methods below:

Method 1:

- a. Attach straps (A) to adapter frame (B) and the forks of the forklift.

NOTE:

Use straps rated for overhead lifting with a minimum working load of 454 kg (1000 lb.).

- b. Pick up the frame and position it against the header.

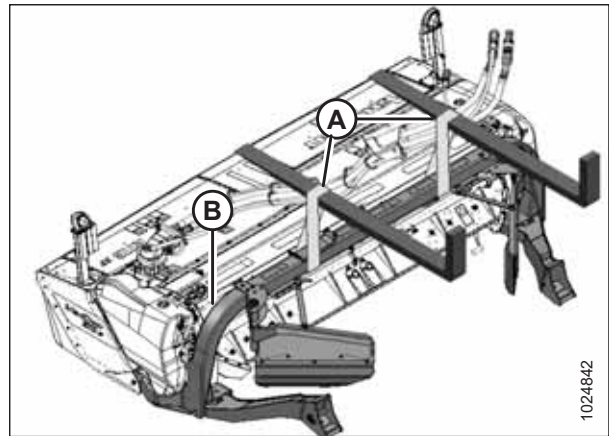

Figure 4.24: Supporting Frame Using Straps

Method 2:

- a. To protect the finish on the frame, wrap packing foam (A) around the frame as shown.
- b. Position forks (B) under the packing foam on the frame as shown. Raise the forks and lift the frame slightly.

NOTE:

The forks should not directly contact the frame.

- c. To secure the frame to the forks, wrap chain (C) around the end of the forks and attach it to the forklift.
- d. Pick up the frame and position it against the header.

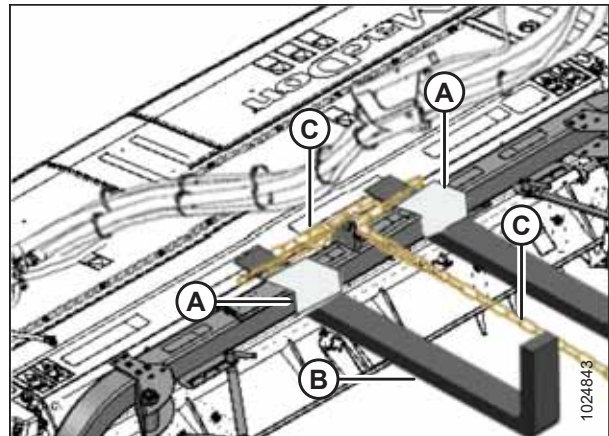

Figure 4.25: Supporting Frame Using Chain

14. Slowly move the conditioner forward until lift arm (C) is aligned with mounting holes (A) and (B) in the frame.

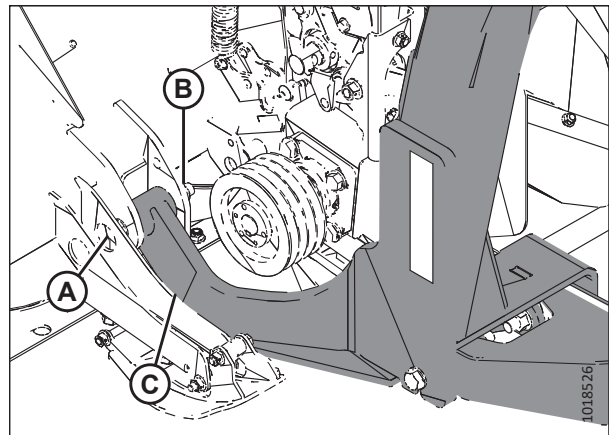

Figure 4.26: Frame – Left Side Shown

CHANGING CONDITIONER

15. Install bolt (A) through frame (B) and bushing (D) in the lift arm. Repeat this step for the opposite side of the machine.
16. Check gaps (C) between bushing inner steel sleeve (D) and frame (B).

NOTE:

If there is a gap, install 1.2 mm thick flat washers to minimize the gap on both sides of the bushing.

17. Remove bolt (A).

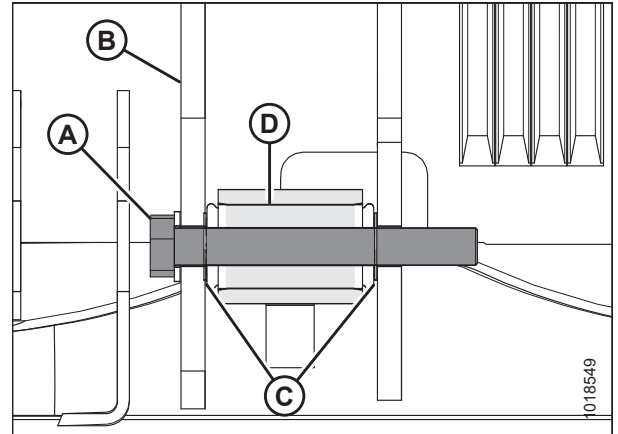

Figure 4.27: Frame Attachment – Left Side Shown

18. Apply anti-seize compound to the shank of bolt (B).

NOTE:

Do **NOT** apply anti-seize compound to the bolt threads.

19. Install washer (A) onto bolt (B).
20. Install bolt (B) with washers (C) as determined in Step 16, page 33.
21. Install three washers (D) and nut (E) onto the bolt.
22. Torque the bolt to 339 Nm (250 lbf-ft).
23. Repeat Step 16, page 33 to Step 21, page 33 for the opposite side of the machine.

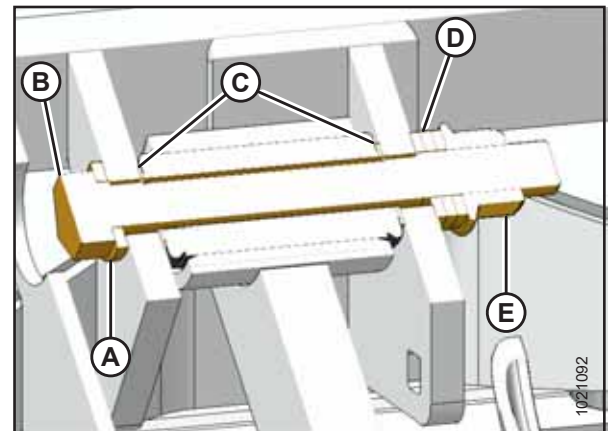

Figure 4.28: Frame Attachment – Cross Section View

24. With flat washer shim (A) on both sides of the center-link support, install securing bolt (B) and washer (C) through the conditioner center-link support bracket and the center-link support.
25. Install nut (D) and torque it to 339 Nm (250 lbf-ft).

NOTE:

Some sections are made hidden in the illustration to help clarify the position of shims (A).

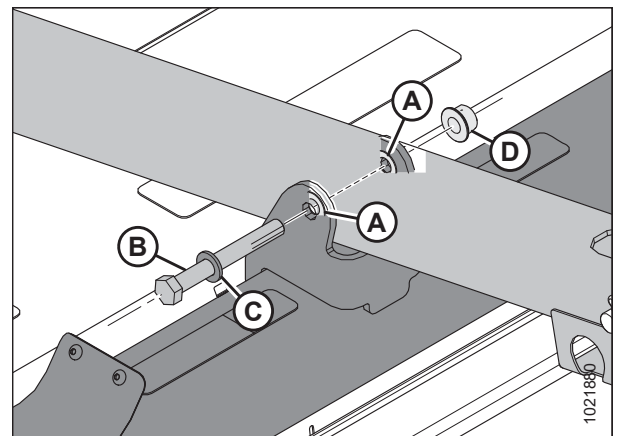

Figure 4.29: Center-Link Support

CHANGING CONDITIONER

WARNING

To prevent the frame from slipping off of the forks, ensure that the frame is secured to the forks. Failure to do so could result in death or serious injury.

26. Lift the header and remove wooden blocks (A) under the skid shoes.
27. Lower the header to the ground.
28. Remove any straps or chains securing the frame to the forks, and back the forklift away from the work area.

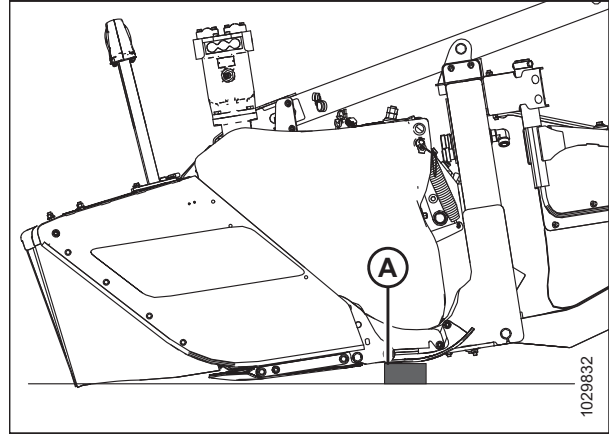

Figure 4.30: Header on Blocks

29. **M155 and M155E4 Windrowers:** Position the hose bundle and hose support (B) onto the adapter and secure it with bolts and nuts (A).

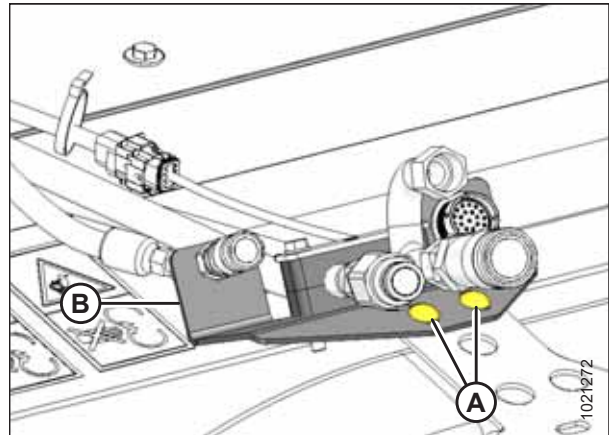

Figure 4.31: M155 and M155E4 Hose Support

30. **M1/M2 Series and M205 Windrowers:** Reposition hose bundle (A) on the frame.

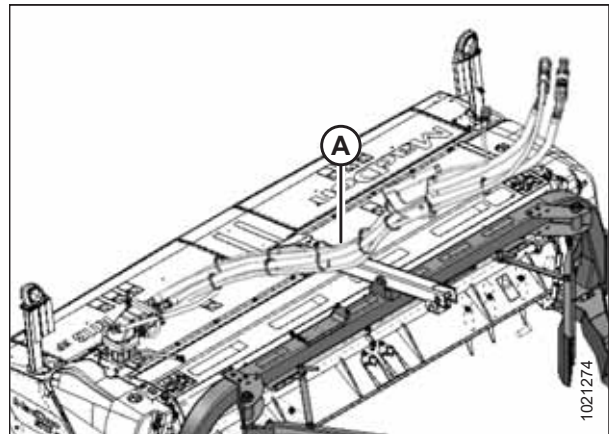

Figure 4.32: Windrower Hose Bundle

CHANGING CONDITIONER

31. Install drive belt (A) onto driven pulley (C) first, and then onto drive pulley (B), ensuring that the belt is in the pulley grooves.

NOTE:

If necessary, loosen the jam nut and adjuster nut to relieve the spring tension.

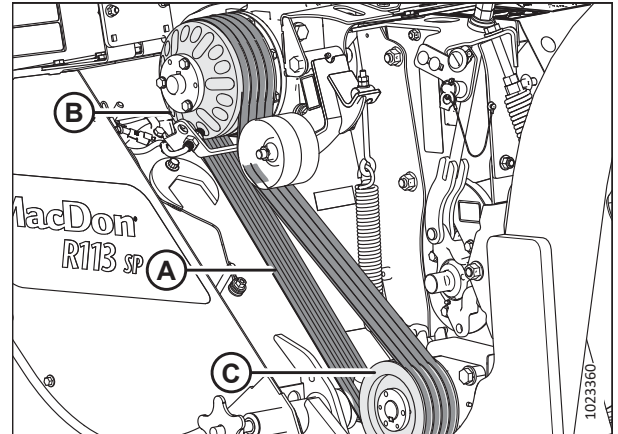

Figure 4.33: Conditioner Drive

32. Measure the length of tensioner spring (C). Dimension (D) should be set to 365 mm (14 3/8 in.) to ensure that the belt is tensioned correctly.
33. To adjust the spring tension, loosen jam nut (A).
34. Turn adjuster nut (B) clockwise to increase the belt tension, or turn adjuster nut (B) counterclockwise to decrease the belt tension.
35. Once the correct spring measurement has been achieved, hold adjuster nut (B) and tighten jam nut (A) against it.

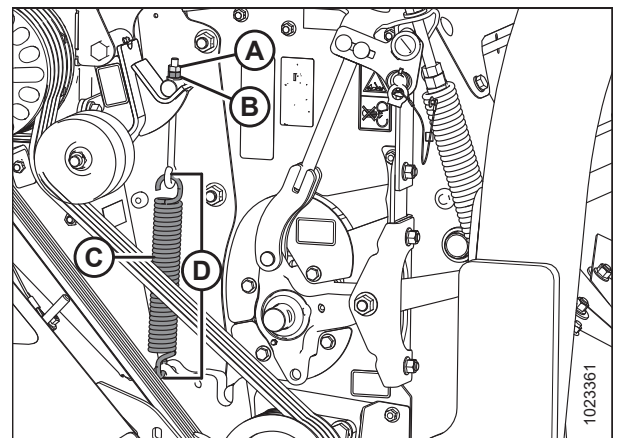

Figure 4.34: Conditioner Drive

36. Reconnect speed sensor (B) to wiring harness (A).

NOTE:

Use the bottom hole for M1 Series and M2 Series Windrowers; use the top hole for M Series Windrowers.

37. Close the driveshields. For instructions, refer to [11.2 Closing Driveshields, page 129](#).

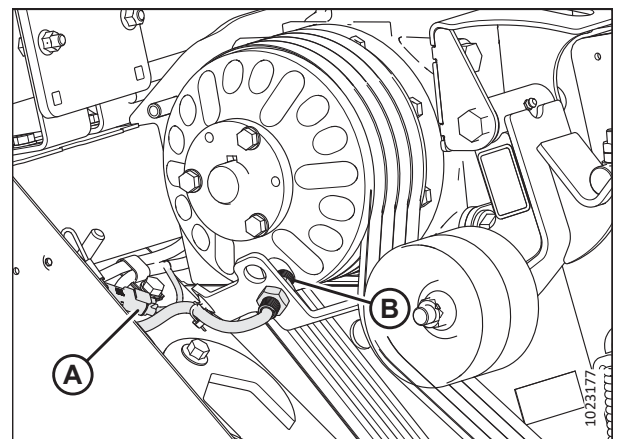

Figure 4.35: Speed Sensor

CHANGING CONDITIONER

4.4.1 Installing Conditioner Drive

This procedure describes the installation of conditioner drive components on a machine that was originally supplied with no conditioner. If a conditioner is to be installed on the header, refer to [4.4 Installing Conditioner, page 30](#).

Retrieve the bag containing the following parts from the conditioner shipment:

- Shaft key
- Pulley
- Bushing with three M10 bolts
- Tensioner assembly
- M16 hex head bolt
- M16 nut
- Two M10 nuts
- Eye bolt
- Hardened washer
- Spring

1. Remove drive cover (A) from left side of header by removing hex head bolt (B), flat washer (C), and nut (D), and sliding cover off pins (E).

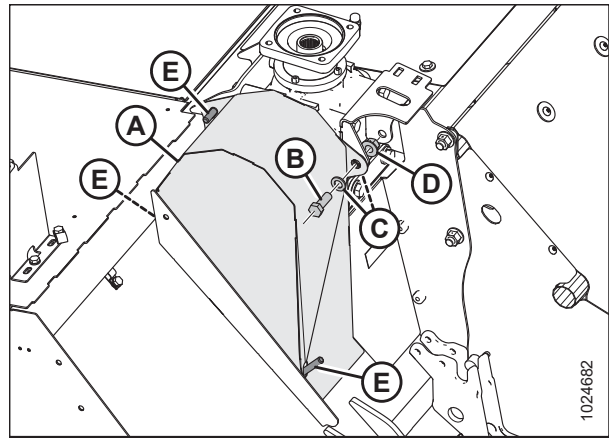

Figure 4.36: Drive Cover

2. Position tensioner assembly (A) as shown, and secure with M16 x 120 bolt (B) and nut (C). Torque nut (C) to 54 Nm (40 lbf-ft).

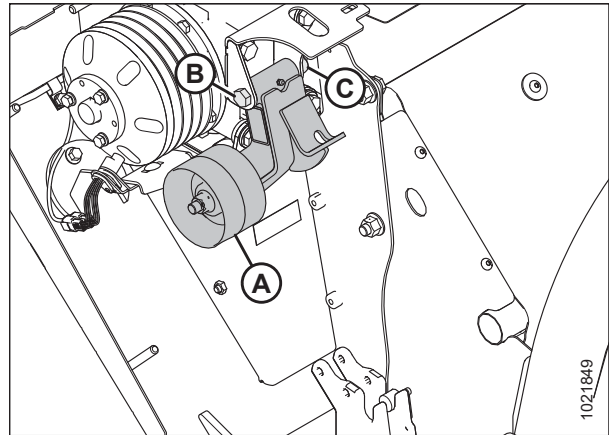

Figure 4.37: Tensioner

CHANGING CONDITIONER

3. Install spring (A) into forward hole (B) in frame.
4. Install eyebolt (C) onto spring (A) and tensioner (D). Secure eyebolt (C) to tensioner (D) with hardened washer (E), and two M10 nuts (F), and straight pin (G).

NOTE:

Install conditioner drive belt after reattaching header to the adapter.

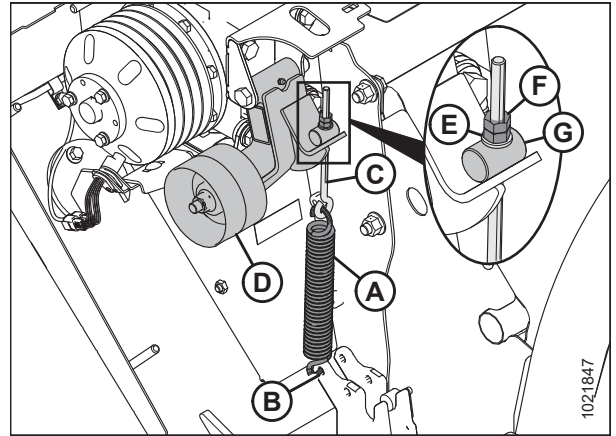

Figure 4.38: Tensioner

4.5 Discharge Shield – No Conditioner

Discharge shields control the distribution of unconditioned crop when no conditioner is installed.

- If a conditioner is being installed, the discharge shield needs to be removed. For instructions, refer to [4.5.1 Removing Discharge Shield – No Conditioner, page 38](#).
- If a conditioner is being removed, the discharge shield needs to be installed. For instructions, refer to [4.5.2 Installing Discharge Shield – No Conditioner, page 39](#).

4.5.1 Removing Discharge Shield – No Conditioner

The discharge shields on a rotary disc header may occasionally need to be removed for machine service.

IMPORTANT:

The discharge shield must be installed if operating the machine without a conditioner.

⚠ DANGER

Ensure that all bystanders have cleared the area.

1. On both ends of the header, remove four M16 hex head bolts, nuts, and flat washers (A) securing shield (B) to header panel (C).

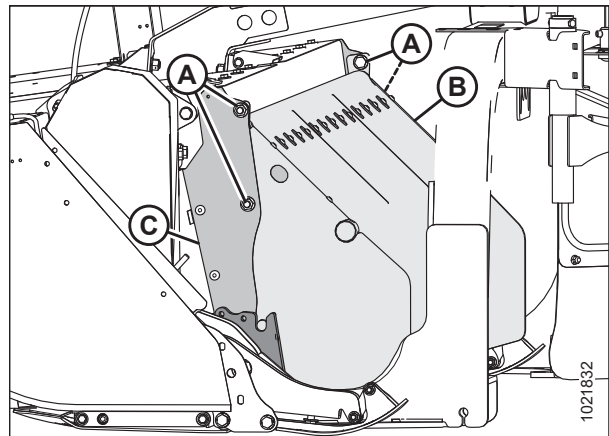

Figure 4.39: Left Side of Header – Right Opposite

2. Lift shield (A) until pins (B) (one on each side) disengage from the slots in support (C).

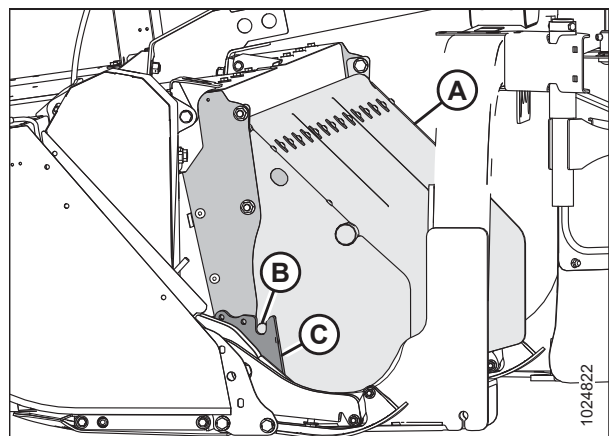

Figure 4.40: Left Side of Header – Right Opposite

4.5.2 Installing Discharge Shield – No Conditioner

The discharge shields on a rotary disc header may occasionally need to be removed for machine service.

IMPORTANT:

The discharge shield must be installed if operating the machine without a conditioner.

⚠ DANGER

Ensure that all bystanders have cleared the area.

1. Position shield (A) until pins (B) (one on each side) engage the slots in support (C) and the bolt holes in shield (A) align with holes (D) in the header.

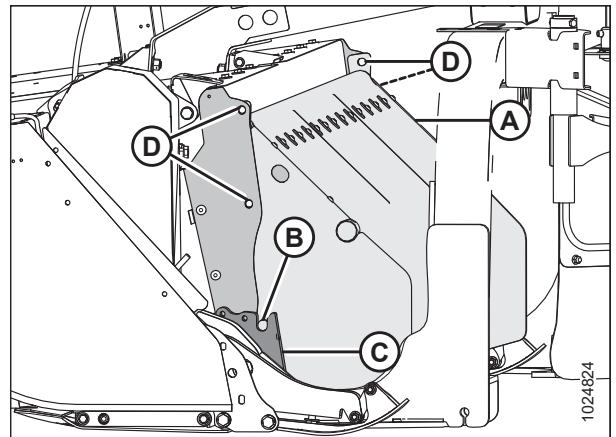

Figure 4.41: Left Side of Header – Right Opposite

2. Secure shield (B) to the header with four M16 hex head bolts (A), nuts, and flat washers.
3. Ensure the bolt heads face inboard and torque the nuts to 261 Nm (193 lbf·ft).

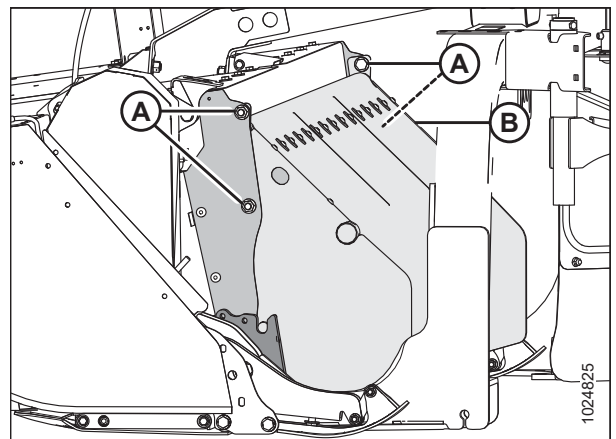

Figure 4.42: Left Side of Header – Right Opposite

Chapter 5: Attaching Header to Windrower

The procedure for attaching a rotary disc header to a windrower varies depending on the windrower model and how that windrower is equipped.

Proceed to the procedure that is suitable for your windrower:

- [5.1 Attaching Header to M2 Series Windrower, page 41](#)
- [5.2 Attaching Header to M1 Series Windrower, page 48](#)
- [5.3 Attaching Header to M155, M155E4, or M205 Self-Propelled Windrower – Hydraulic Center-Link with Self-Alignment, page 55](#)
- [5.4 Attaching Header – Hydraulic Center-Link without Self-Alignment, page 61](#)

5.1 Attaching Header to M2 Series Windrower

The windrower's lift linkage and center-link will need to be connected to the header.

IMPORTANT:

The R113 Rotary Disc Header is compatible with an M2170 or M2260 Windrower, but **NOT** an M2170 NT Windrower.

DANGER

To prevent bodily injury or death from the unexpected start-up or fall of a raised machine, always stop the engine and remove the key before leaving the operator's seat, and always engage the safety props before going under the machine for any reason.

DANGER

Ensure that all bystanders have cleared the area.

1. Shut down the engine, and remove the key from the ignition.
2. Remove hairpin (A) from clevis pin (B), and remove the pin from header support (C). Remove the hairpin and the clevis pin from the other header support.
3. Start the engine.

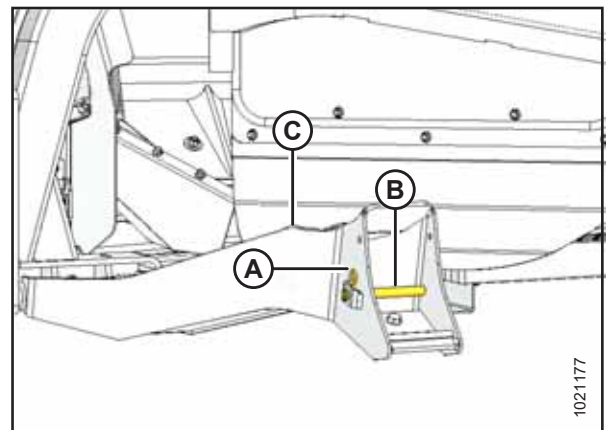

Figure 5.1: Header Support

ATTACHING HEADER TO WINDROWER

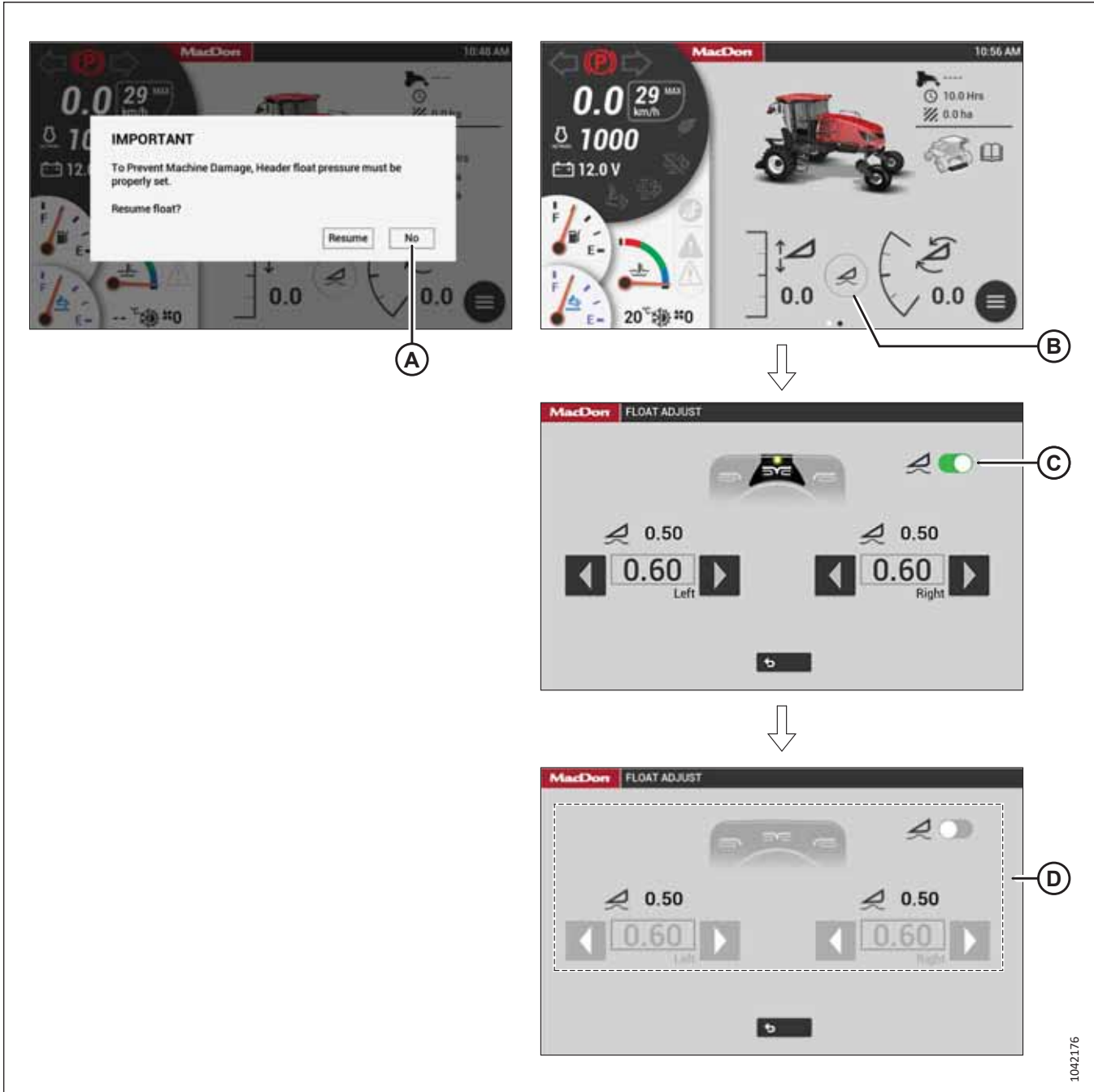

Figure 5.2: Float Removal

4. Remove the float as follows:

- If the HarvestTouch™ Display shows the message “Resume Float?”, then select NO (A).
- If the HarvestTouch™ Display does **NOT** show the message, then select FLOAT ADJUST (B), select switch (C), and confirm the switch and float settings (D) are grayed out.

IMPORTANT:

Removing the float will release the tension in the float springs. This will prevent damage to the header lift linkages when lowering the legs without a header or weight box attached to the windrower.

ATTACHING HEADER TO WINDROWER

- Prepare the center-link as follows:
 - If not equipped with the Center-Link Alignment kit:** Relocate pin (A) in the frame linkage as needed to raise center-link (B) until the hook is above the attachment pin on the header.
 - If equipped with the Center-Link Alignment kit:** Press REEL UP switch (D) on the ground speed lever (GSL) to raise the center-link until the hook is above the attachment pin on the header.

IMPORTANT:

Ensure that the center-link is positioned high enough that it does not contact the header as the windrower approaches the header.

- Press HEADER DOWN switch (C) on the GSL until the windrower lift linkages are fully lowered.

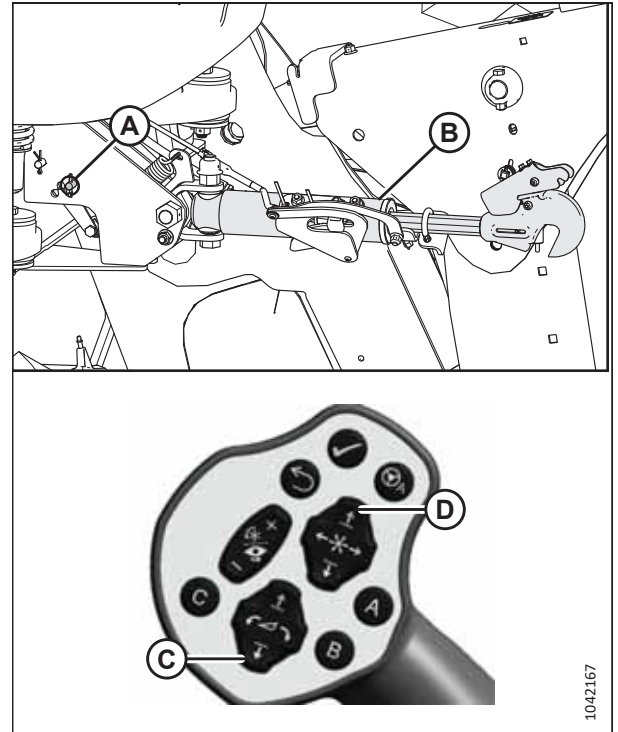

Figure 5.3: Center-Link without Self-Alignment

- Slowly drive the windrower forward until feet (A) enter header supports (B). Continue to drive forward until the feet engage the supports and the header nudges forward.
- Ensure that feet (A) are properly engaged in header supports (B).

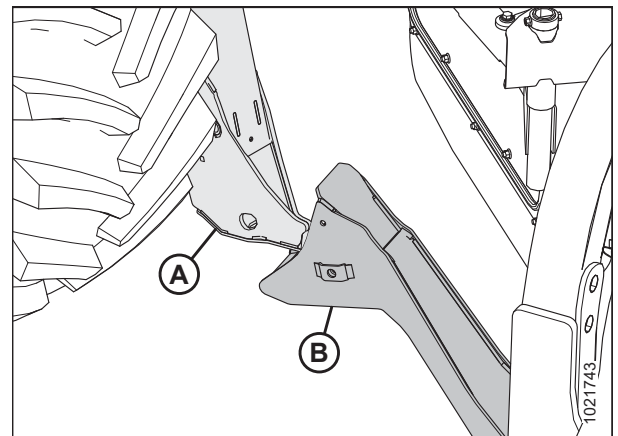

Figure 5.4: Header Support

ATTACHING HEADER TO WINDROWER

9. Windrowers equipped with the Center-Link Alignment kit:

- Press HEADER TILT UP (A) or HEADER TILT DOWN (B) switches on the GSL to extend or retract the center-link cylinder until hook (C) is aligned with the header attachment pin.
- Lower the center-link onto the header with REEL DOWN (D) switch on the GSL until the center-link locks into position and hook release (E) is down.

IMPORTANT:

The hook release must be down to enable the self-locking mechanism. If the hook release is open (in the up position), manually push it down after the hook engages the pin.

- Check that the center-link is locked onto the header by pressing REEL UP (F) switch on the GSL.

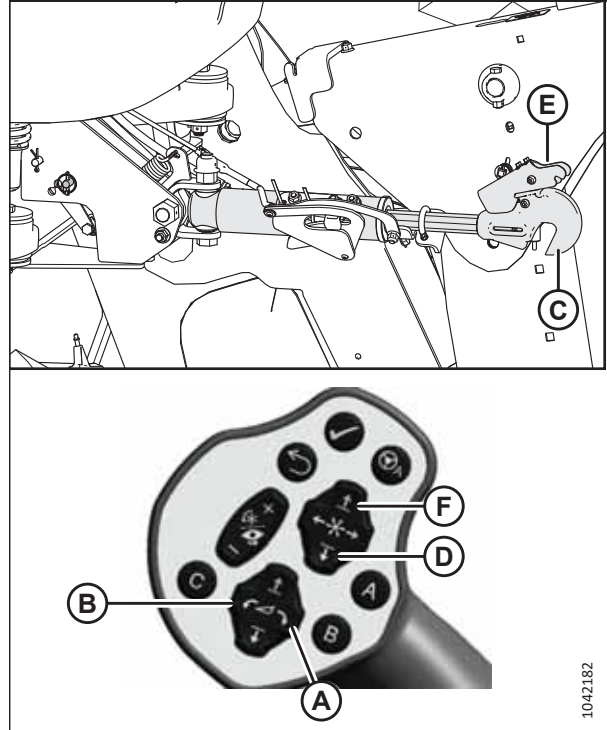

Figure 5.5: Hydraulic Center-Link

10. Windrowers without the Center-Link Alignment kit:

- Press HEADER TILT UP (A) or HEADER TILT DOWN (B) switches on the GSL to extend or retract the center-link cylinder until the hook is aligned with the header attachment pin.
- Shut down the engine, and remove the key from the ignition.
- Push down on rod end (C) of the link cylinder until hook (D) engages and locks onto the header pin.

IMPORTANT:

Hook release (E) must be down to enable the self-locking mechanism. If the hook release is open (in the up position), manually push it down after the hook engages the pin.

- Check that the center-link is locked onto the header by pulling upward on rod end (C) of the cylinder.
- Start the engine.

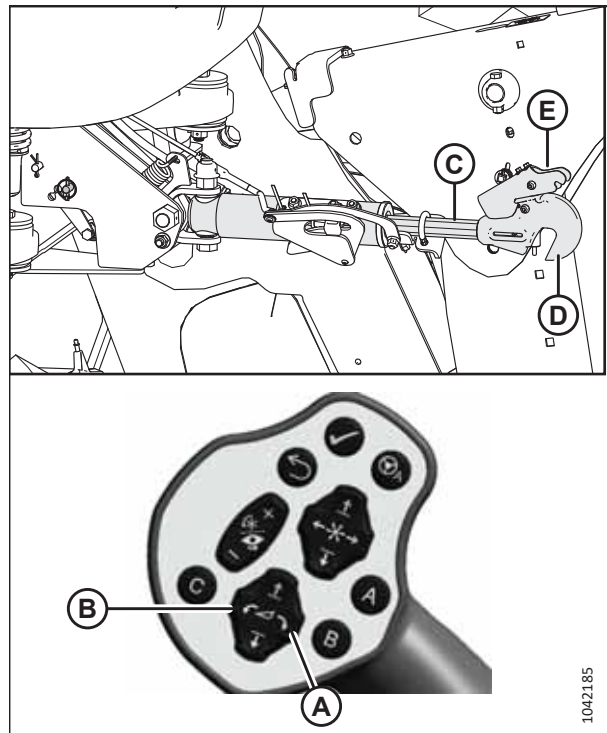

Figure 5.6: Hydraulic Center-Link

ATTACHING HEADER TO WINDROWER

11. Press HEADER UP switch (A) to raise the header to its maximum height.

NOTE:

If one end of the header does **NOT** fully rise, rephase the lift cylinders as follows:

- a. Press and hold HEADER UP switch (A) until both cylinders stop moving.
 - b. Continue to hold the switch for 3–4 seconds. The cylinders are now phased.
12. Shut down the engine, and remove the key from the ignition.

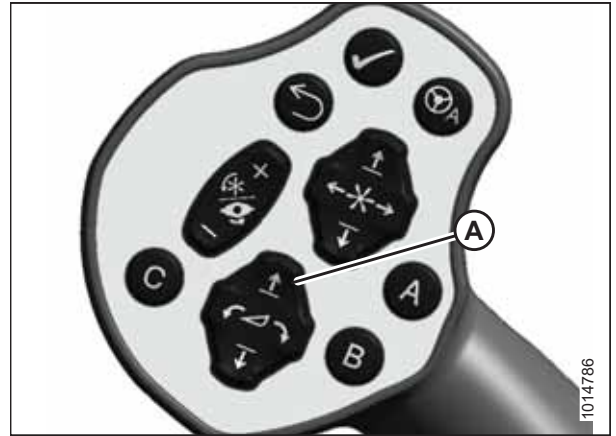

Figure 5.7: Ground Speed Lever (GSL)

13. Engage the safety props on both lift cylinders as follows:

- a. Pull lever (A) toward you to release it, then rotate it toward the header to lower the safety prop onto the cylinder.
- b. Repeat the previous step for the opposite lift cylinder.

IMPORTANT:

Ensure that the safety props engage over the cylinder piston rods. If the safety prop does **NOT** engage properly, raise the header until the safety prop fits over the rod.

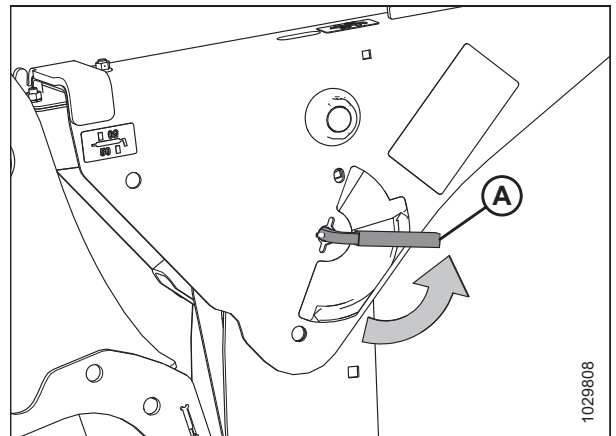

Figure 5.8: Safety Prop Lever

14. Install clevis pin (A) through the support and the windrower lift arm and secure the clevis pin with hairpin (B). Install the clevis pin and the hairpin on the opposite side of the header.

IMPORTANT:

Ensure that clevis pin (A) is inserted as far as possible and that the hairpin is installed behind the bracket as shown.

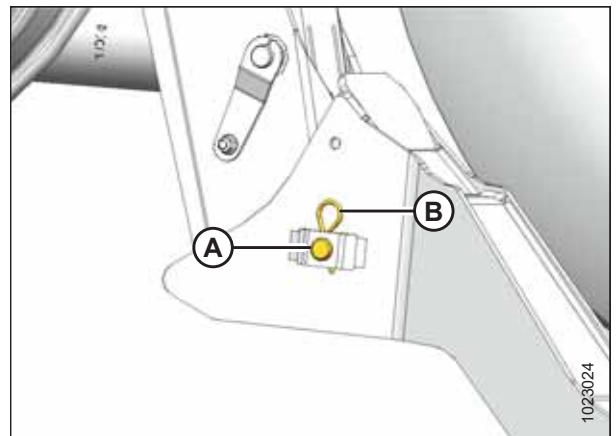

Figure 5.9: Header Support

ATTACHING HEADER TO WINDROWER

15. Disengage the safety props on both lift cylinders as follows:
 - a. Turn lever (A) away from the header to raise the safety prop until the lever locks into the vertical position.
 - b. Repeat the previous step for the opposite cylinder.

NOTE:

If the safety prop will **NOT** disengage, raise the header to release the prop.

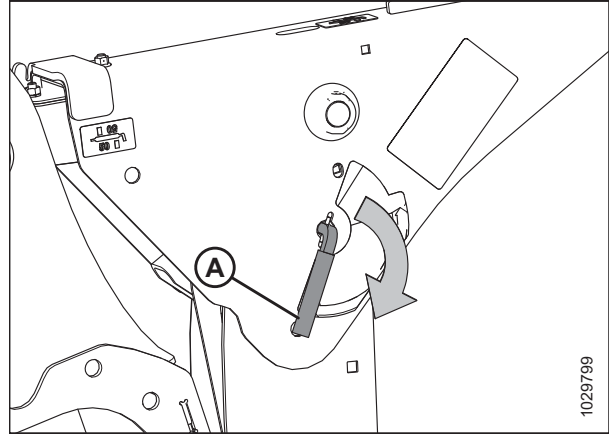

Figure 5.10: Safety Prop Lever

16. Press HEADER DOWN switch (A) on the GSL to fully lower the header.

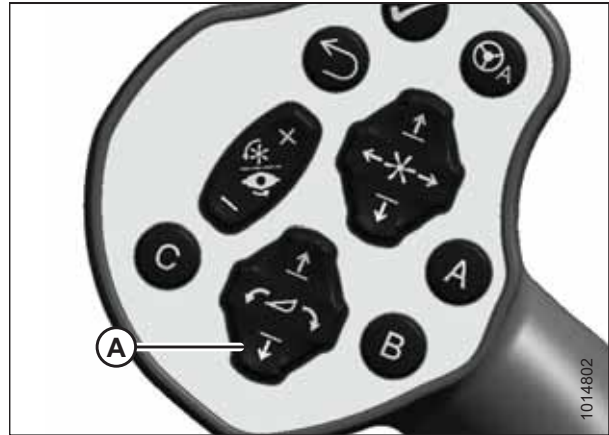

Figure 5.11: Ground Speed Lever (GSL)

17. Select FLOAT ADJUST (A).

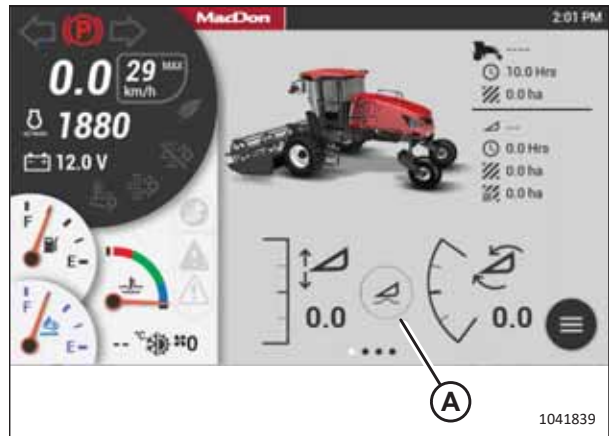

Figure 5.12: HarvestTouch™ Display

ATTACHING HEADER TO WINDROWER

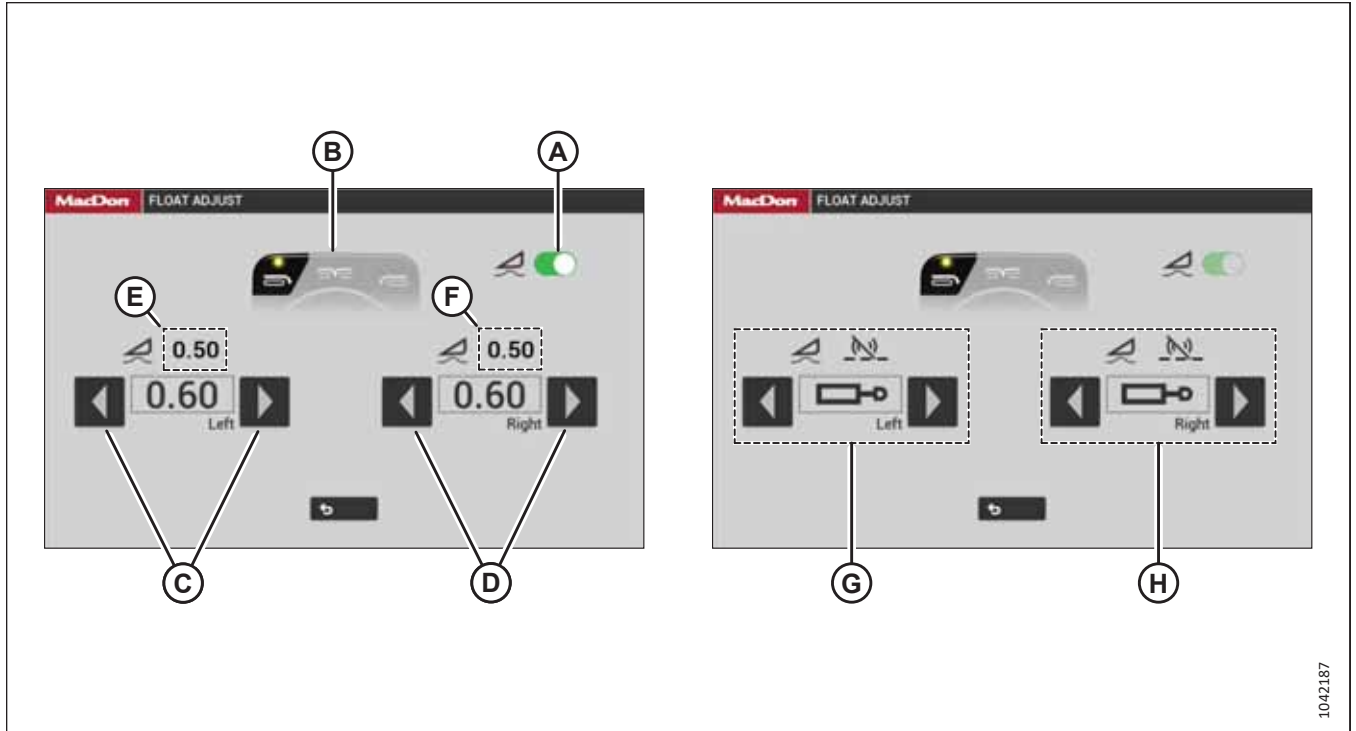

Figure 5.13: Float Adjustment

18. Select switch (A), so that it turns green, to activate the float.

19. If the float is not already set up, set the float as follows:

- The float preset, which is selected using the operator's console, is displayed at location (B). Confirm if the desired preset is selected.
- Select arrows (C) to set the target float for the left side of the header. Value (E) is the actual amount of float (measured by the left float sensor).
- Select arrows (D) to set the target float for the right side of the header. Value (F) is the actual amount of float (measured by the left float sensor).

NOTE:

Adjusting the float by increments of 1.0 (out of 10) changes the header weight at the cutterbar by approximately 91 kg (200 lb.). Adjust the float in increments of 0.05 to fine-tune the header's performance.

20. Shut down the engine, and remove the key from the ignition.

21. Check the float as follows:

- Grasp one end of the header and lift it. The lifting force used should be 426–471 N (95–105 lbf).
- Repeat this step on the other side of the header.

22. Proceed as follows:

- If you are attaching the header to an M2170 Windrower, proceed to [6.1 Connecting Header Hydraulic and Electrical Systems – M2170 Windrower, page 67](#).
- If you are attaching the header to an M2260 Windrower, proceed to [6.2 Connecting Header Hydraulic and Electrical Systems – M2260 Windrower, page 71](#).

5.2 Attaching Header to M1 Series Windrower

The procedure for attaching the header to an M1 Series Windrower varies depending on whether or not the self-aligning center-link is installed.

IMPORTANT:

The R113 Rotary Disc Header is compatible with the M1170 and M1240 Windrowers, but **NOT** the M1170 *NT* and M1170 *NT5* Windrowers.

⚠ DANGER

To prevent bodily injury or death from the unexpected startup of the machine, always stop the engine and remove the key from the ignition before leaving the operator's seat for any reason.

⚠ DANGER

Ensure that all bystanders have cleared the area.

1. Shut down the engine, and remove the key from the ignition.
2. Locate hydraulic center-link (A).

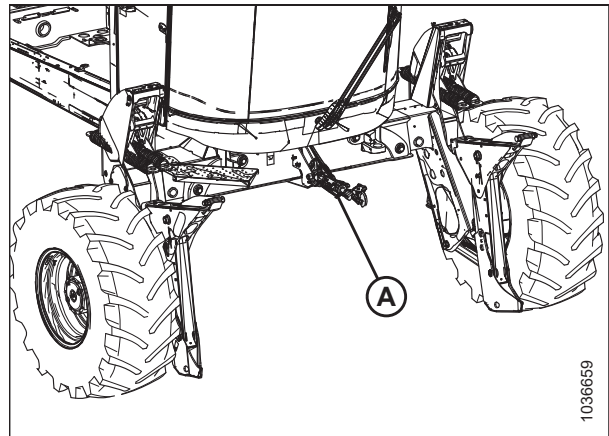

Figure 5.14: Hydraulic Center-Link Location

3. **Hydraulic center-link without self-alignment:** Remove pin (A) and raise center-link (B) until the hook is above the attachment pin on the header. Replace pin (A) to hold the center-link in place.

IMPORTANT:

If the center-link is too low, it may contact the header as the windrower approaches the header.

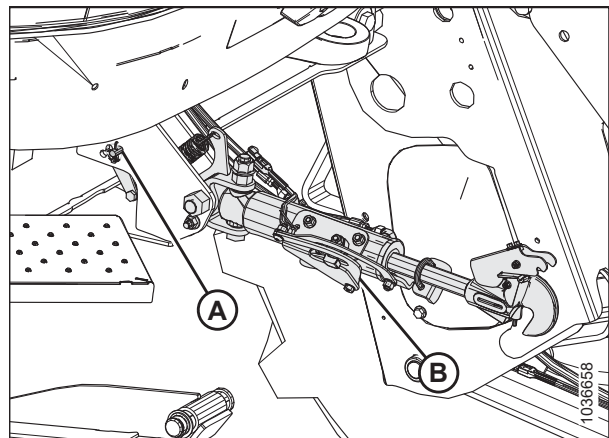

Figure 5.15: Hydraulic Center-Link and Pin

ATTACHING HEADER TO WINDROWER

4. Remove hairpin (A) from clevis pin (B) from header support (C) on both sides of the header.

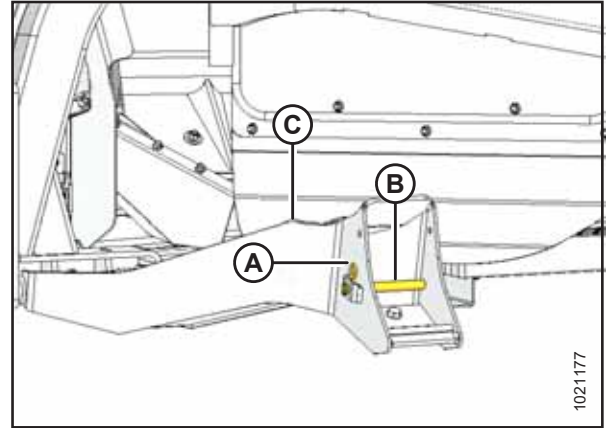

Figure 5.16: Header Support

5. If you are lowering the header lift legs with a header or weight box attached, proceed to Step 9, page 50.
If you are lowering the header lift legs without a header or weight box attached, proceed to Step 6, page 49 to release the tension from header float springs (A).

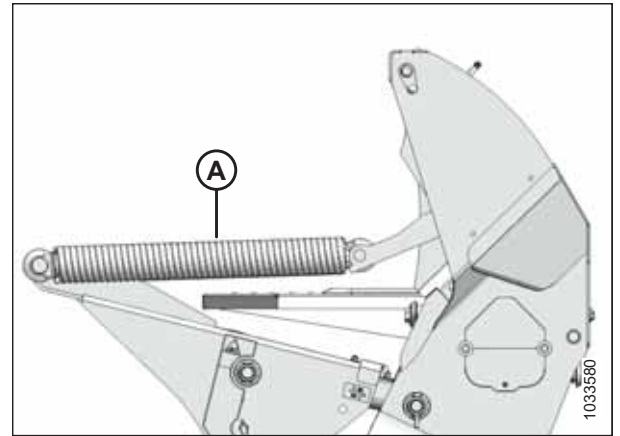

Figure 5.17: Header Float Springs

6. Press rotary scroll knob (A) on the Harvest Performance Tracker (HPT) to highlight the QuickMenu options.
7. Rotate scroll knob (A) to highlight HEADER FLOAT symbol (B), and press the scroll knob to select it. The Float Adjust page appears.



Figure 5.18: HPT Display

ATTACHING HEADER TO WINDROWER

- Press soft key 3 (A) to remove the header float.

NOTE:

If the header float is active, the icon at soft key 3 will display REMOVE FLOAT; if the header float has been removed, then the icon will display RESUME FLOAT.



Figure 5.19: HPT Display

- Press HEADER DOWN switch (E) on the ground speed lever (GSL) to fully retract the header lift cylinders.
- Self-aligning hydraulic center-link:** Press REEL UP switch (B) on the GSL to raise the center-link until the hook is above the attachment pin on the header.

IMPORTANT:

If the center-link is too low, it may contact the header as the windrower approaches the header.

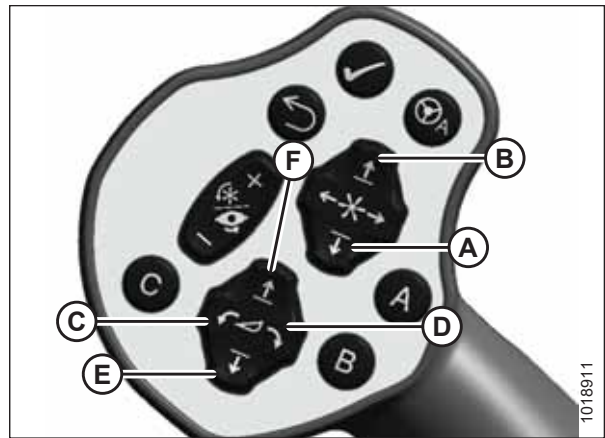

Figure 5.20: GSL

A - Reel Down	B - Reel Up
C - Header Tilt Down	D - Header Tilt Up
E - Header Down	F - Header Up

- Slowly drive the windrower forward until feet (A) enter header supports (B). Continue to drive forward until the feet engage the supports and the header nudges forward.
- Ensure that feet (A) properly engage header supports (B).

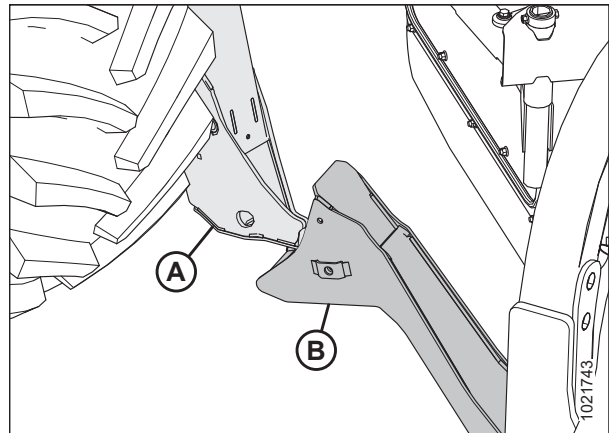

Figure 5.21: Header Support

ATTACHING HEADER TO WINDROWER

13. Windrowers equipped with the Center-Link Alignment kit:

- a. Adjust the position of center-link cylinder (A) with the switches on the GSL until hook (B) is above the header attachment pin.

IMPORTANT:

Hook release (C) must be down to enable the self-locking mechanism to function.

- b. If hook release (C) is open (in the up position), shut down the engine, and remove the key from the ignition. Manually push hook release (C) down after the hook engages the header pin.
- c. Lower center-link (A) onto the header with the REEL DOWN switch on the GSL until the center-link locks into position and hook release (C) is down.
- d. Check that the center-link is locked onto the header by pressing the REEL UP switch on the GSL.

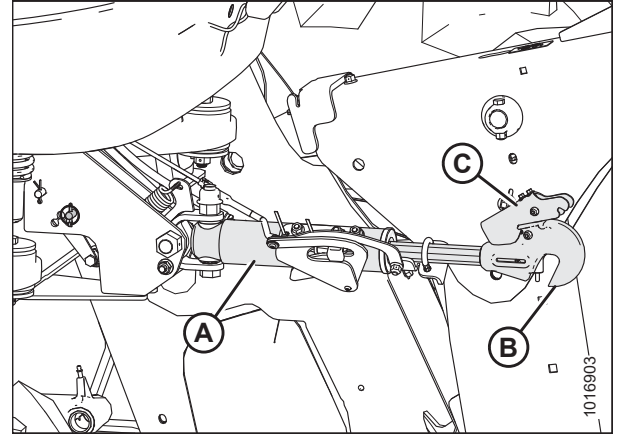

Figure 5.22: Hydraulic Center-Link

14. Windrowers without the Center-Link Alignment kit:

- a. Press the HEADER TILT UP or HEADER TILT DOWN cylinder switches on the GSL to extend or retract the center-link cylinder until the hook is aligned with the header attachment pin.
- b. Shut down the engine, and remove the key from the ignition.
- c. Push down on rod end (B) of the link cylinder until the hook engages and locks onto the header pin.

IMPORTANT:

The hook release must be down to enable the self-locking mechanism to function. If the hook release is open (in the up position), manually push it down after the hook engages the pin.

- d. Check that center-link (A) is locked onto the header by pulling upward on rod end (B) of the cylinder.
- e. Start the engine.

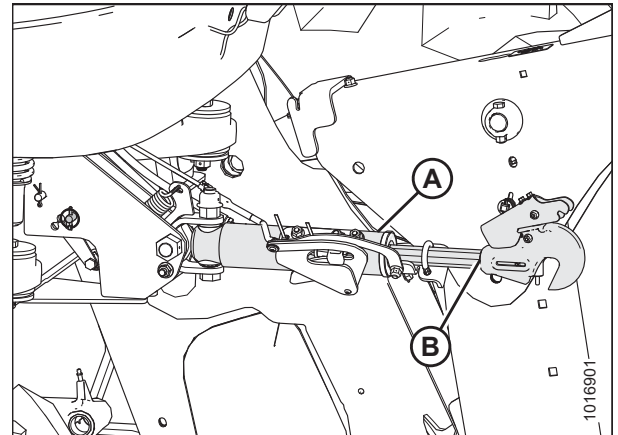

Figure 5.23: Hydraulic Center-Link

ATTACHING HEADER TO WINDROWER

15. Press HEADER UP switch (A) to fully raise the header.

NOTE:

If one end of the header does **NOT** fully raise, rephase the lift cylinders as follows:

- Press and hold HEADER UP switch (A) until both cylinders stop moving.
- Continue to hold the switch for 3–4 seconds. The cylinders are now phased.

16. Shut down the engine, and remove the key from the ignition.

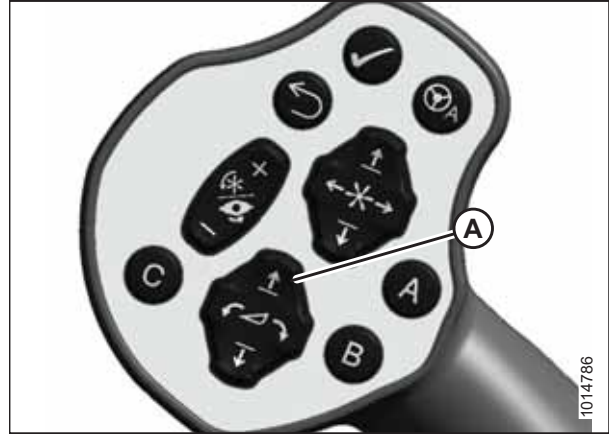

Figure 5.24: GSL

17. Engage the safety props on both lift cylinders as follows:

- Pull lever (A) toward you to release it, then rotate it toward the header to lower the safety prop onto the cylinder.
- Repeat the previous step for the opposite lift cylinder.

IMPORTANT:

Ensure that the safety props engage over the cylinder piston rods. If the safety prop does **NOT** engage properly, raise the header until the safety prop fits over the rod.

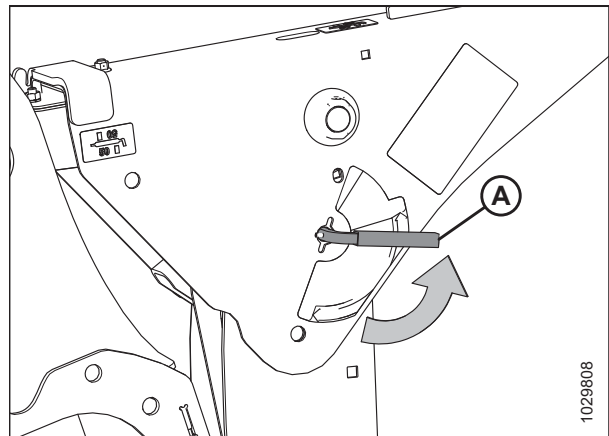

Figure 5.25: Safety Prop Lever

18. Install clevis pin (A) through the header support and the windrower lift arm. Secure the clevis pin with hairpin (B). Repeat this step for the opposite side of the header.

IMPORTANT:

Ensure that clevis pin (A) is fully inserted and that the hairpin is behind the bracket.

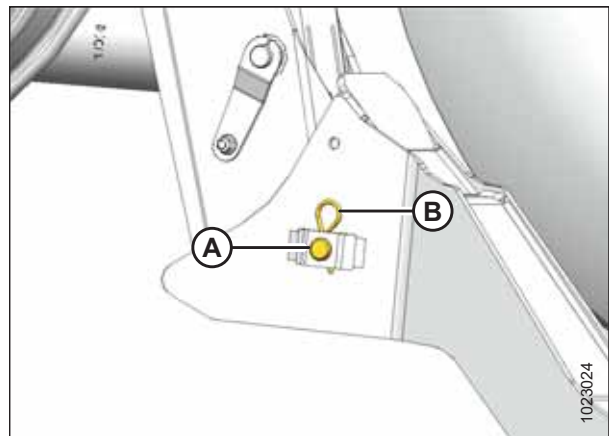

Figure 5.26: Header Support

ATTACHING HEADER TO WINDROWER

19. Disengage the safety props on both lift cylinders as follows:
 - a. Turn lever (A) away from the header to raise the safety prop until the lever locks into the vertical position.
 - b. Repeat the previous step for the opposite cylinder.

NOTE:

If the safety prop will **NOT** disengage, raise the header to release the prop.

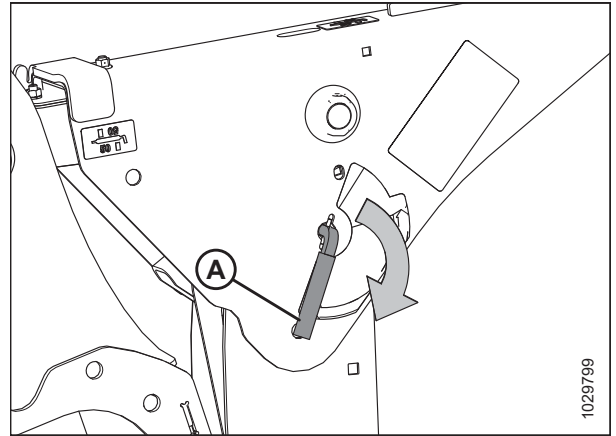

Figure 5.27: Safety Prop Lever

20. Press HEADER DOWN switch (A) on the GSL to fully lower the header.
21. Shut down the engine, and remove the key from the ignition.

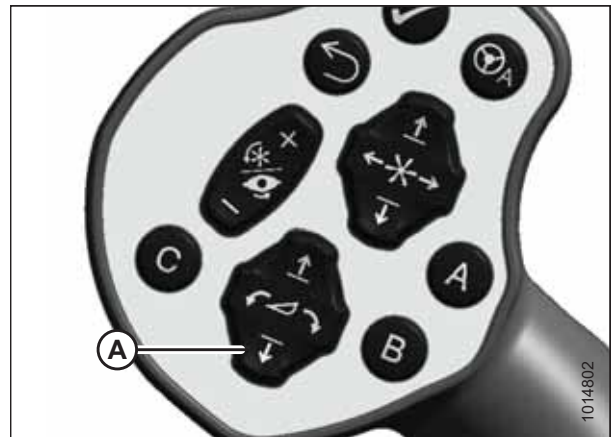

Figure 5.28: GSL

22. If you are not prompted by the HPT display to restore the header float, restore the header float manually by doing the following:
 - a. Press rotary scroll knob (A) on the HPT to highlight the QuickMenu options.
 - b. Rotate scroll knob (A) to highlight Header Float icon (B), and press the scroll knob to select it.



Figure 5.29: HPT Display

ATTACHING HEADER TO WINDROWER

23. Press soft key 3 (A) to restore the header float.

NOTE:

If the header float is active, the icon at soft key 3 will display Remove Float; if the header float has been removed, then the icon will display Resume Float.

24. Shut down the engine, and remove the key from the ignition.



Figure 5.30: HPT Display

5.3 Attaching Header to M155, M155E4, or M205 Self-Propelled Windrower – Hydraulic Center-Link with Self-Alignment

The header will need to be physically attached to the windrower, and the hydraulic and electrical connections completed. The windrower may be equipped with an optional self-aligning hydraulic center-link, which allows the Operator to control the vertical position of the center-link from the cab.

⚠ DANGER

To prevent bodily injury or death from the unexpected start-up or fall of a raised machine, always stop the engine and remove the key before leaving the operator's seat, and always engage the safety props before going under the machine for any reason.

⚠ DANGER

Ensure that all bystanders have cleared the area.

1. Shut down the engine, and remove the key from the ignition.
2. Locate header supports (A) on the rear of the header.

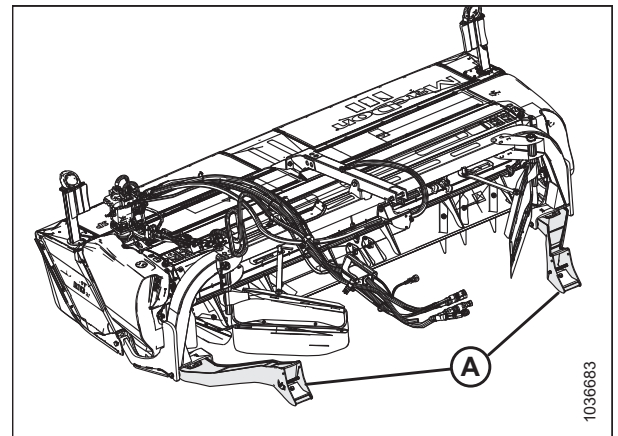

Figure 5.31: Header Supports

3. Remove hairpin (B) from clevis pin (A) and remove the clevis pin from header support (C) on both sides of the header.

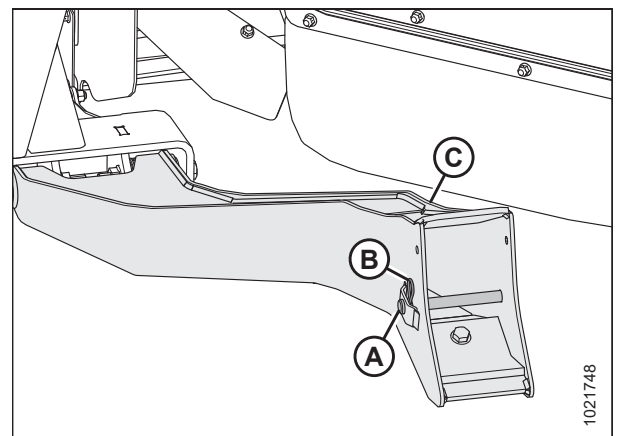

Figure 5.32: Header Support

ATTACHING HEADER TO WINDROWER

4. Remove the float engagement pin from hole (A) to disengage the float springs, and insert the float engagement pin into storage hole (B). Secure the pin with the lynch pin. Repeat this step for the opposite linkage.

IMPORTANT:

To prevent damage to the lift system when lowering the header lift linkages without a header or a weight box attached to the windrower, ensure that the float engagement pin is installed in storage hole (B) and **NOT** in engaged position (A).

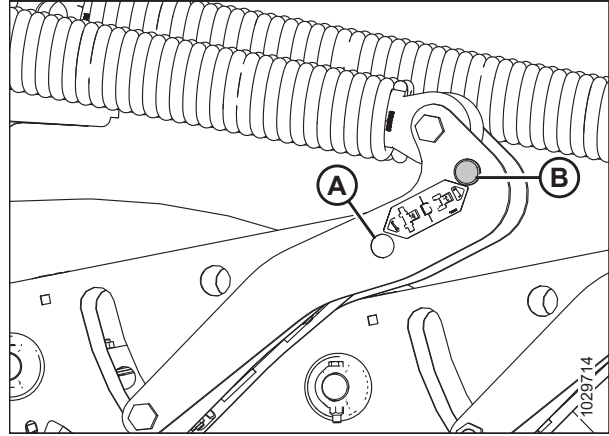

Figure 5.33: Float Linkage

5. Activate HEADER DOWN button (A) on the ground speed lever (GSL) to fully retract the header lift cylinders.

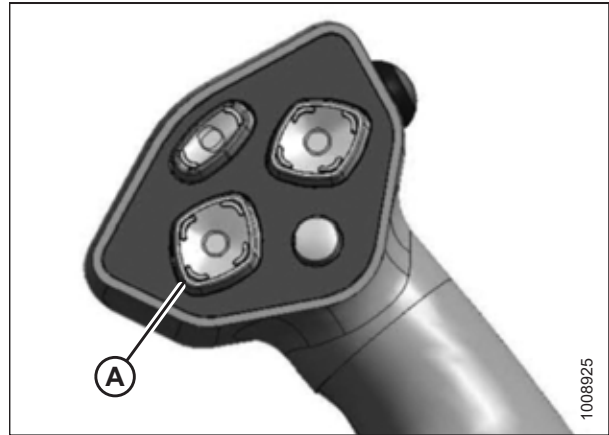

Figure 5.34: Ground Speed Lever

6. Press REEL UP switch (A) on the GSL to raise the center-link until the hook is above the attachment pin on the header.

IMPORTANT:

If the center-link is too low, it may contact the header as the windrower approaches the header for hookup.



Figure 5.35: Ground Speed Lever

ATTACHING HEADER TO WINDROWER

7. Slowly drive the windrower forward until windrower feet (A) enter header supports (B). Continue driving slowly forward until the feet engage the supports and the header is nudged forward.

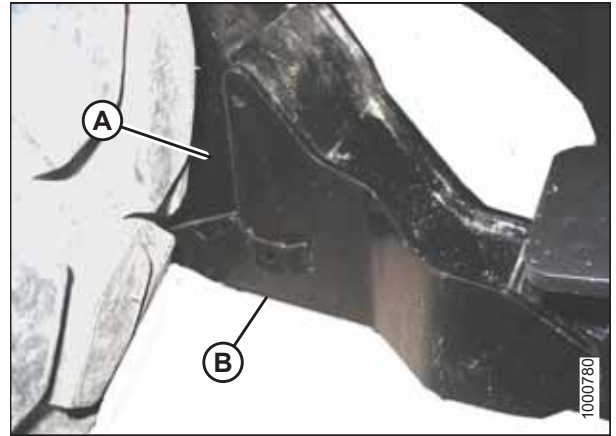

Figure 5.36: Header Support

8. Use the following GSL functions to position the center-link hook above the header attachment pin:
 - REEL UP (A) to raise the center-link
 - REEL DOWN (B) to lower the center-link
 - HEADER TILT UP (C) to retract the center-link
 - HEADER TILT DOWN (D) to extend the center-link

IMPORTANT:

The hook release must be down to enable the self-locking mechanism. If the release is open (up), manually push it down after the hook engages the header pin.

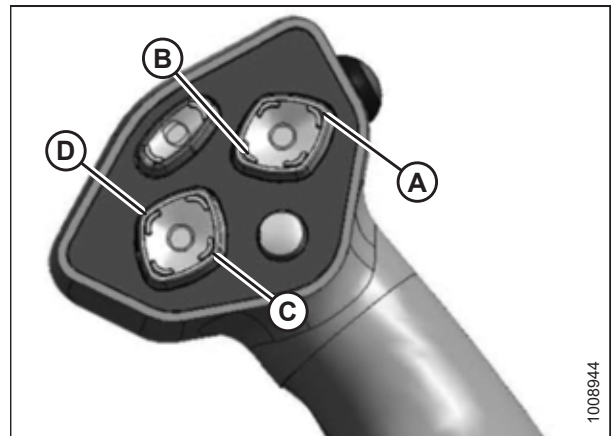

Figure 5.37: Ground Speed Lever

9. Adjust the position of center-link cylinder (A) with the REEL UP and REEL DOWN switches on the GSL until the hook is positioned above the header attachment pin.

IMPORTANT:

Hook release (B) must be down to enable the self-locking mechanism. If the release is open (up), manually push it down after the hook engages the header pin.

10. Lower center-link (A) onto the header using the REEL DOWN switch on the GSL until the center-link locks into position and hook release (B) is down.
11. Check that the center-link is locked onto the header by pressing the REEL UP switch on the GSL.

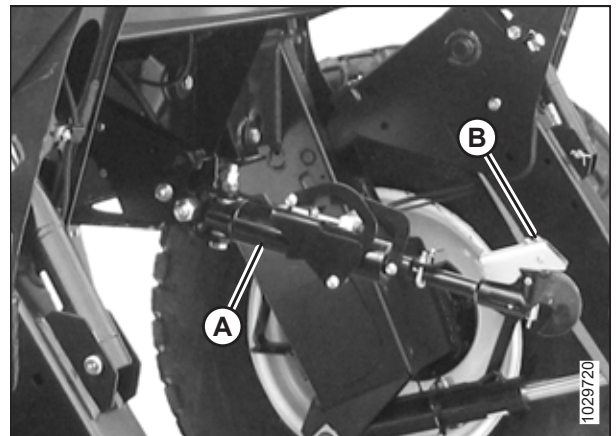

Figure 5.38: Hydraulic Center-Link

ATTACHING HEADER TO WINDROWER

12. Press HEADER UP switch (A) to raise the header to its maximum height.
13. If one end of the header does **NOT** fully rise, rephase the lift cylinders as follows:
 - a. Press and hold the HEADER UP switch until both cylinders stop moving.
 - b. Continue to hold the switch for 3–4 seconds to fully phase the cylinders.

NOTE:

It may be necessary to repeat this procedure if there is air in the hydraulic system.



Figure 5.39: Ground Speed Lever

14. Engage the safety props on both lift cylinders:
 - a. Shut down the engine, and remove the key from the ignition.
 - b. Pull lever (A) and rotate it towards the header to release and lower safety prop (B) onto the lift cylinder.
 - c. Repeat the previous steps for the opposite lift cylinder.

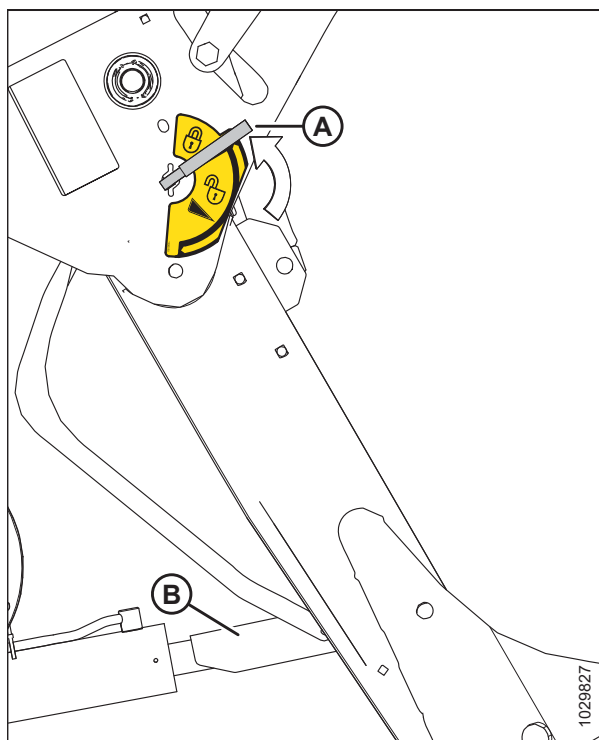

Figure 5.40: Safety Prop

ATTACHING HEADER TO WINDROWER

15. Install clevis pin (A) through the support and the windrower lift member, and secure it with hairpin (B). Repeat this step for the opposite side of the machine.

IMPORTANT:

Ensure that clevis pin (A) is fully inserted and that the hairpin is installed behind the bracket.

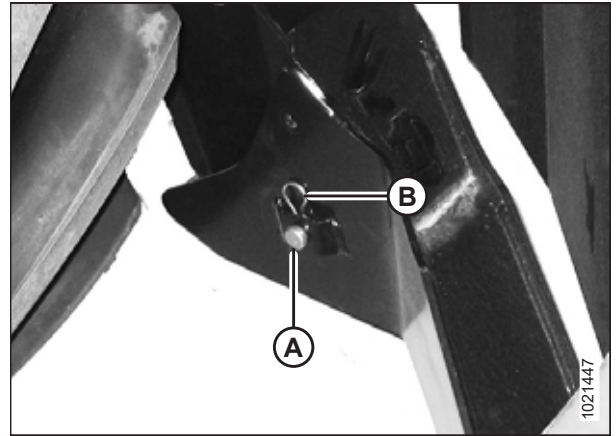

Figure 5.41: Header Support

16. Remove the clevis pin from storage position (B) in the linkage and insert it into hole (A) to engage the float springs. Repeat this step on the opposite float linkage.

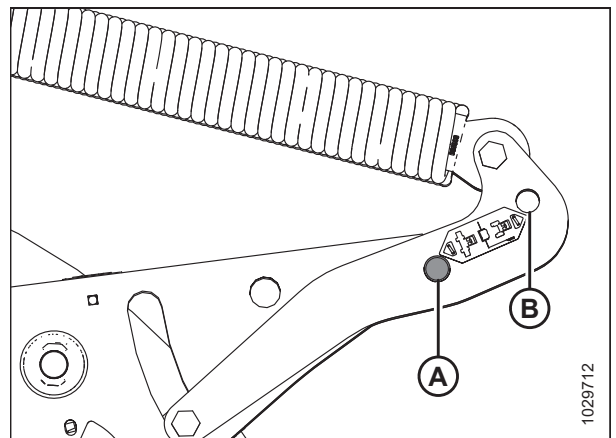

Figure 5.42: Header Float Linkage

17. Disengage the safety prop by turning lever (A) downwards until the lever locks into the vertical position.
18. Repeat the previous step to disengage the other safety prop.

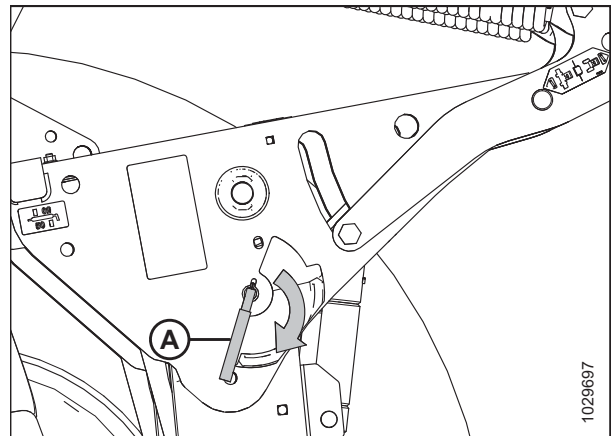

Figure 5.43: Safety Prop Lever

ATTACHING HEADER TO WINDROWER

19. Press HEADER DOWN switch (A) on the GSL to fully lower the header.
20. Shut down the engine, and remove the key from the ignition.



Figure 5.44: Ground Speed Lever

5.4 Attaching Header – Hydraulic Center-Link without Self-Alignment

The header will need to be physically attached to the windrower, and the hydraulic and electrical connections completed. If the windrower is equipped with a hydraulic center-link that lacks the self-alignment capability, the Operator will have to manually attach the hydraulic center-link's hook to the header's center pin.

DANGER

To prevent bodily injury or death from the unexpected start-up or fall of a raised machine, always stop the engine and remove the key before leaving the operator's seat, and always engage the safety props before going under the machine for any reason.

DANGER

Ensure that all bystanders have cleared the area.

1. Shut down the engine, and remove the key from the ignition.
2. Locate header supports (A) on the rear of the header.

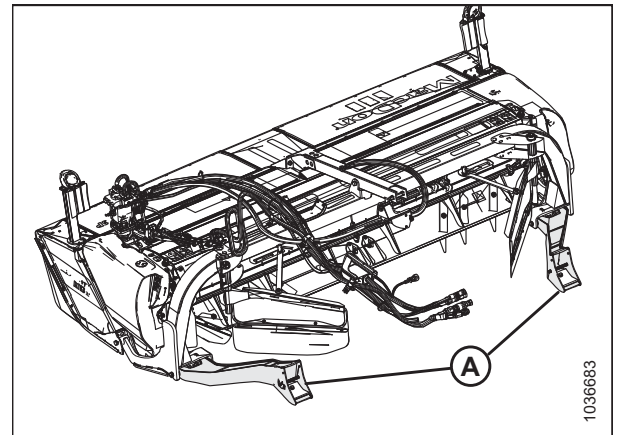

Figure 5.45: Header Supports

3. Remove hairpin (B) and clevis pin (A) from header support (C) on both sides of the header.

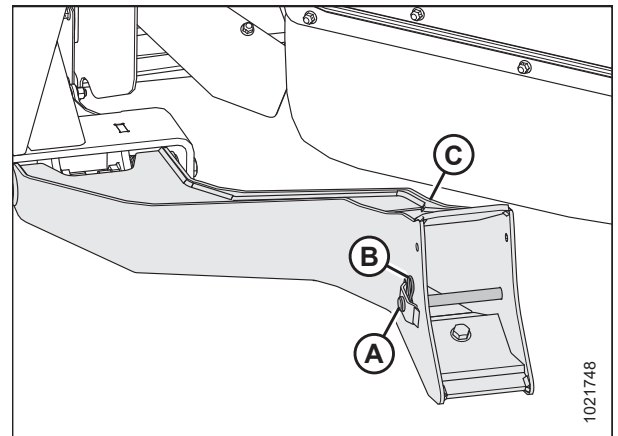

Figure 5.46: Header Support

ATTACHING HEADER TO WINDROWER

4. To disengage the float springs, move the float engagement pin from engaged position (A) and insert the pin into storage hole (B). Secure the float engagement pin with a lynch pin. Repeat this step for the opposite linkage.

IMPORTANT:

To avoid damaging the lift system when lowering the header lift linkages without a header or a weight box attached, ensure that the float engagement pin is installed in storage position (B) and **NOT** in engaged position (A).

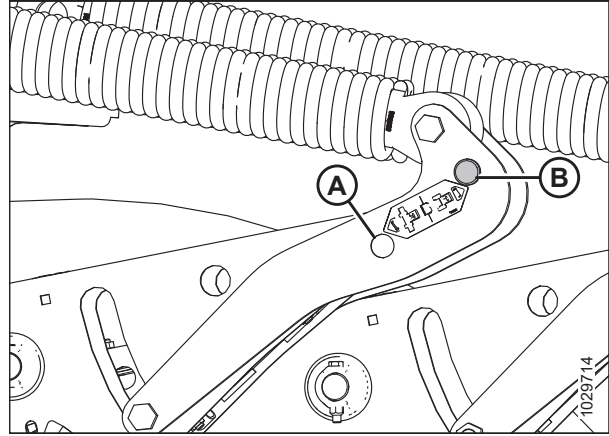

Figure 5.47: Header Float Linkage

5. Activate HEADER DOWN button (A) on the ground speed lever (GSL) to fully retract the header lift cylinders.

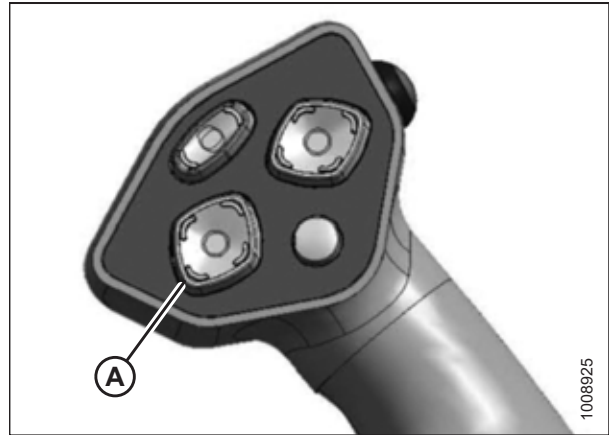

Figure 5.48: Ground Speed Lever

6. Remove pin (A) from the frame linkage and raise center-link (B) until the hook is above the attachment pin on the header. Replace pin (A) to hold the center-link in place.

IMPORTANT:

If the center-link is too low, it may contact the header as the windrower approaches the header for hookup.

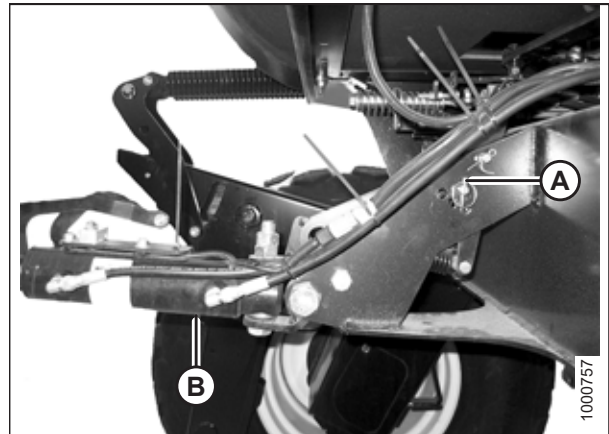

Figure 5.49: Hydraulic Center-Link

ATTACHING HEADER TO WINDROWER

7. Slowly drive the windrower forward until windrower feet (A) enter header supports (B). Continue driving slowly forward until the feet engage the supports and the header nudges forward.

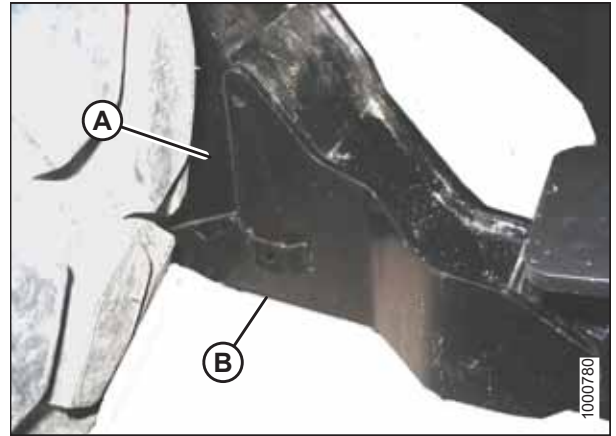

Figure 5.50: Header Support

8. Use the following GSL functions to position the center-link hook above the header attachment pin:
 - HEADER TILT UP (A) to retract the center-link
 - HEADER TILT DOWN (B) to extend the center-link
9. Shut down the engine, and remove the key from the ignition.

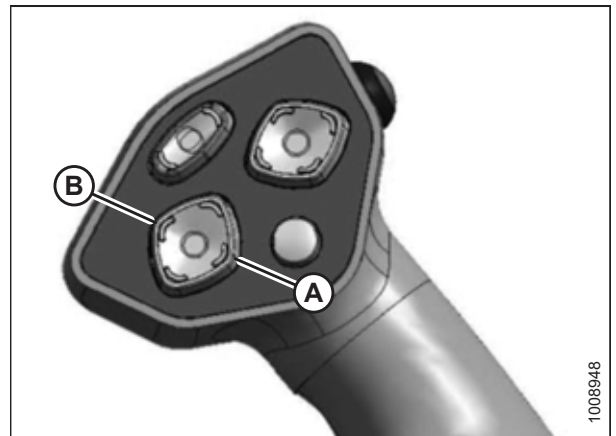

Figure 5.51: Ground Speed Lever

10. Push down on the rod end of link cylinder (A) until hook (B) engages and locks onto the header pin.

IMPORTANT:

The hook release must be down to enable the self-locking mechanism. If the release is open (up), manually push it down after the hook engages the header pin.

11. Check that center-link (A) is locked onto the header by pulling upward on the rod end of the cylinder.

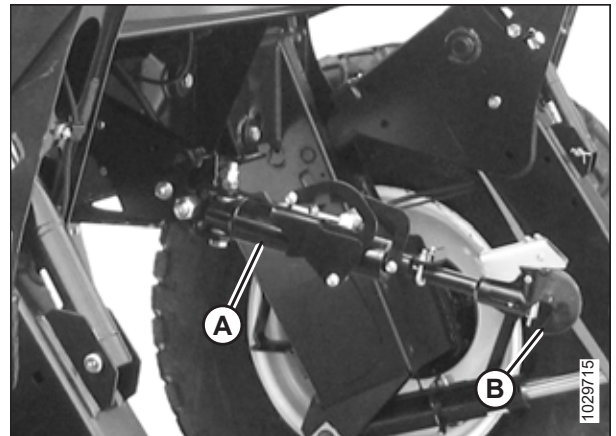

Figure 5.52: Hydraulic Center-Link

ATTACHING HEADER TO WINDROWER

12. Press HEADER UP switch (A) to fully raise the header.
13. If one end of the header does **NOT** fully raise, rephase the lift cylinders as follows:
 - a. Press and hold the HEADER UP switch until both cylinders stop moving.
 - b. Continue to hold the switch for 3–4 seconds. The cylinders are now phased.

NOTE:

It may be necessary to repeat this procedure if there is air in the system.

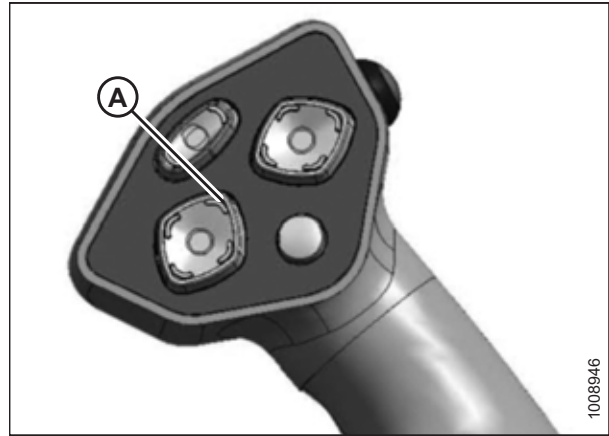

Figure 5.53: Ground Speed Lever

14. Engage the safety props on both lift cylinders:
 - a. Shut down the engine, and remove the key from the ignition.
 - b. Pull lever (A) and rotate it towards the header to release and lower safety prop (B) onto the lift cylinder.
 - c. Repeat the previous steps for the opposite lift cylinder.

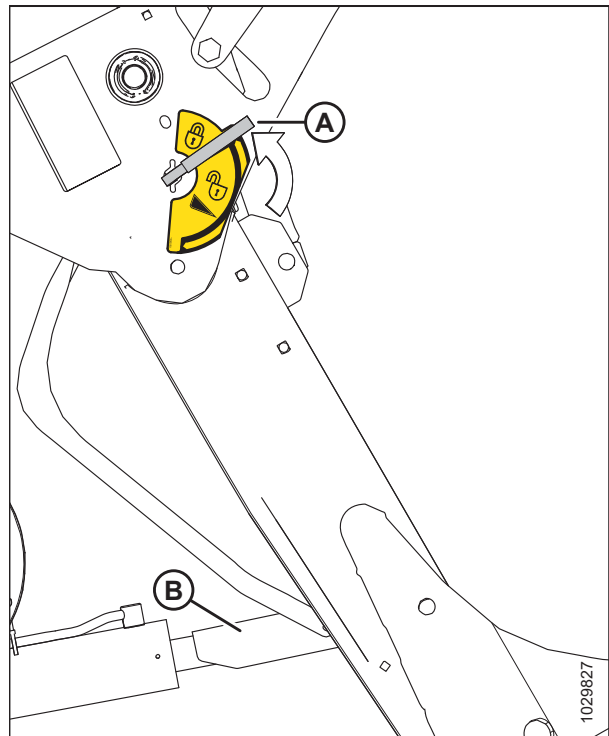

Figure 5.54: Safety Prop

ATTACHING HEADER TO WINDROWER

15. Install clevis pin (A) through the header support and the windrower lift member, and secure the clevis pin with hairpin (B). Repeat this step on the opposite side of the machine.

IMPORTANT:

Ensure that clevis pin (A) is fully inserted and that the hairpin is behind the bracket.

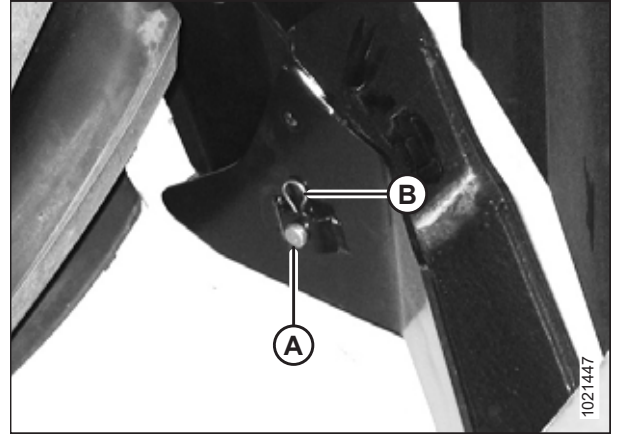

Figure 5.55: Header Support

16. Remove the clevis pin from storage position (B) in the linkage and insert it into hole (A) to engage the float springs. Repeat this step on the opposite float linkage.

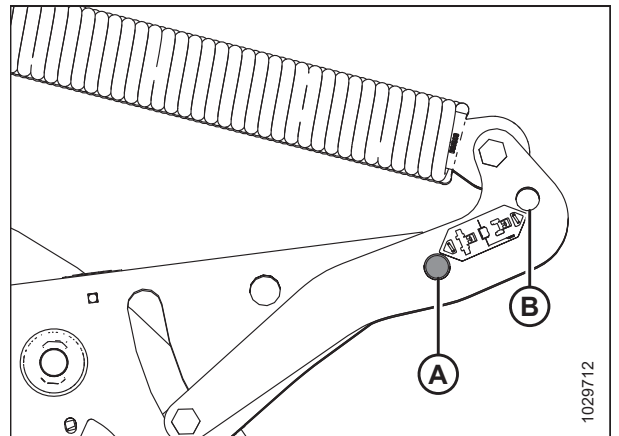

Figure 5.56: Header Float Linkage

17. Disengage the safety prop by turning lever (A) downwards until the lever locks into the vertical position.
18. Repeat the previous step to disengage the other safety prop.

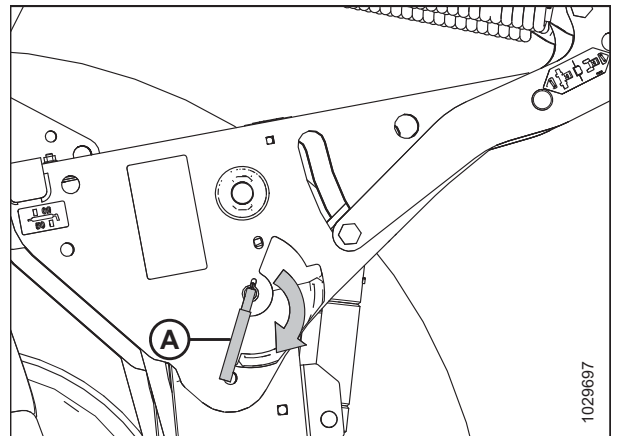

Figure 5.57: Safety Prop Lever

ATTACHING HEADER TO WINDROWER

19. Press HEADER DOWN switch (A) on the GSL to fully lower the header.
20. Shut down the engine, and remove the key from the ignition.



Figure 5.58: Ground Speed Lever

Chapter 6: Attaching Hydraulic and Electrical Components

The procedure for attaching the header hydraulic and electrical components depends on the windrower model.

NOTE:

Hydraulic conversion kits are needed to configure headers for different windrowers. Contact your MacDon Dealer for more information.

Refer to the relevant hydraulic and electrical attachment procedure:

- *6.1 Connecting Header Hydraulic and Electrical Systems – M2170 Windrower, page 67*
- *6.2 Connecting Header Hydraulic and Electrical Systems – M2260 Windrower, page 71*
- *6.3 Connecting Header Hydraulic and Electrical Systems – M1240 Windrower, page 88*
- *6.4 Connecting Header Hydraulic and Electrical Systems – M1170 Windrower, page 94*
- *6.5 Connecting Header Hydraulic and Electrical Systems – M155 or M155E4 Windrowers, page 99*
- *6.6 Connecting Header Hydraulic and Electrical Systems – M205 Windrower, page 106*

6.1 Connecting Header Hydraulic and Electrical Systems – M2170 Windrower

The header's hydraulic and electrical multicoupler will need to be connected to the windrower.



DANGER

To prevent bodily injury or death from the unexpected start-up of the machine, always stop the engine and remove the key from the ignition before making adjustments to the machine.



CAUTION

Do NOT stand on an unlocked platform. It is unstable and may cause you to fall.

IMPORTANT:

To prevent contamination of the hydraulic system, use a clean rag to remove dirt and moisture from all (fixed and movable) hydraulic couplers.

1. Shut down the engine, and remove the key from the ignition.
2. Retrieve the hydraulic hoses from the header.

ATTACHING HYDRAULIC AND ELECTRICAL COMPONENTS

3. Push latch (A) to unlock platform (B).

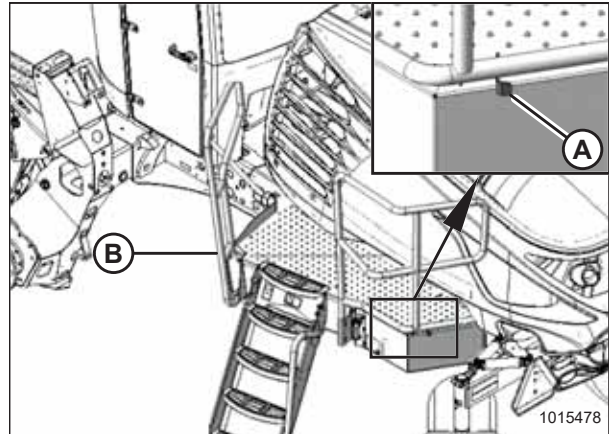

Figure 6.1: Left Platform

4. Pull platform (A) toward the cab until it stops and the latch is engaged.

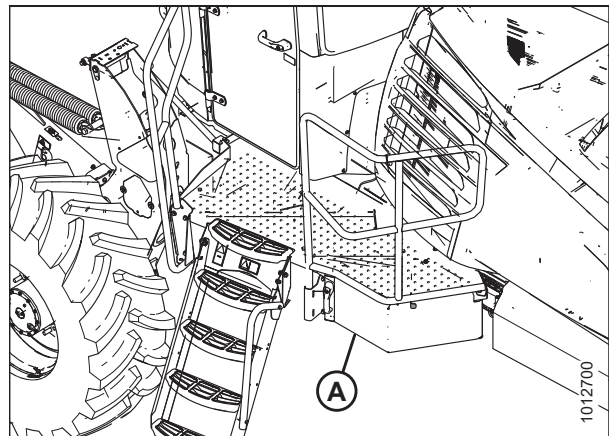

Figure 6.2: Left Platform

5. Attach hose support (A) to the frame near the windrower left cab-forward leg. Route the hoses under the frame.

NOTE:

Ensure that the hoses remain as straight as possible and that they are not subject to damage from abrasion.

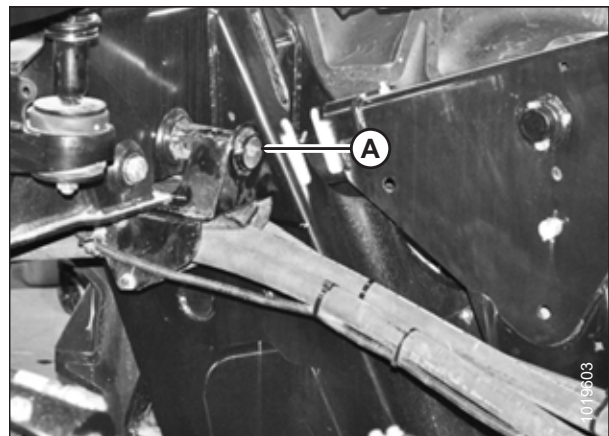

Figure 6.3: Hose Support Attachment

ATTACHING HYDRAULIC AND ELECTRICAL COMPONENTS

6. **If you are replacing an auger header:** Disconnect hose (A) from knife pressure receptacle (C) on the frame.
7. Move the hose to storage location (B).

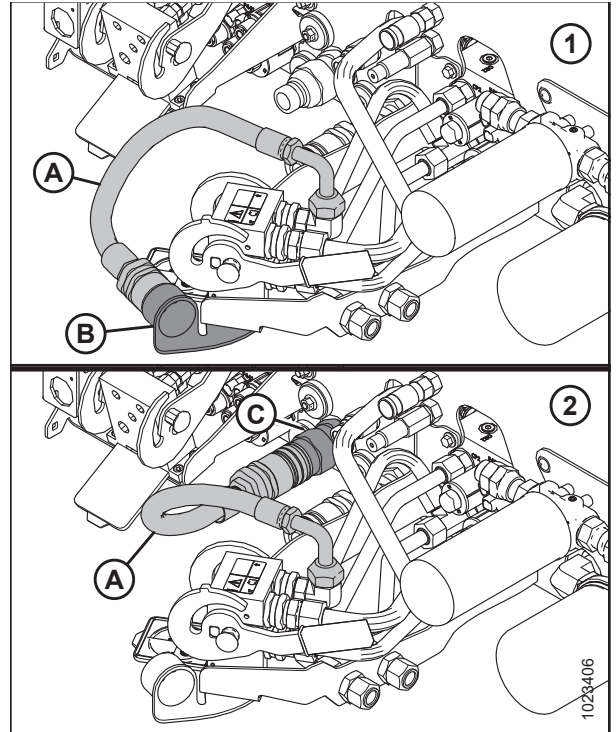

Figure 6.4: Knife Pressure Hose Positions

- 1 - Knife Pressure Hose in Storage Position – Rotary Configuration
- 2 - Hose to Knife Pressure Receptacle – Auger/Draper Configuration

8. Attach the couplers to the receptacles on the windrower as follows:
 - a. Connect the pressure hose female coupler to receptacle (A).
 - b. Connect the return hose male coupler to receptacle (B).
 - c. Connect the case drain hose coupler to receptacle (C).
 - d. Connect the electrical harness to receptacle (D).

IMPORTANT:

The hydraulic hoses should **NOT** come in contact with multicoupler (E). To increase the slack in the hoses, loosen and adjust the hose holder on the front windrower leg before pulling the hoses back toward the windrower.

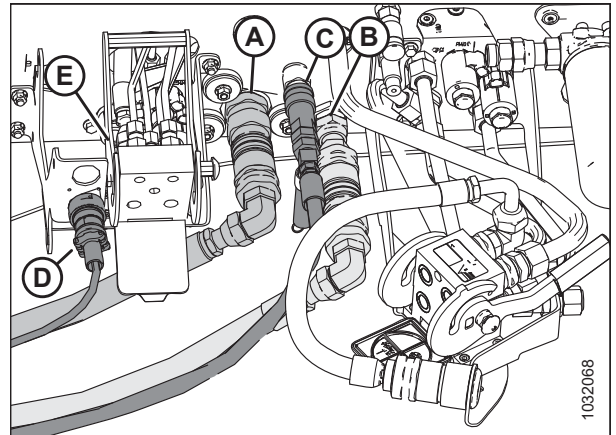

Figure 6.5: Hydraulic and Electrical Connections

ATTACHING HYDRAULIC AND ELECTRICAL COMPONENTS

9. Push latch (A) to unlock platform (B).

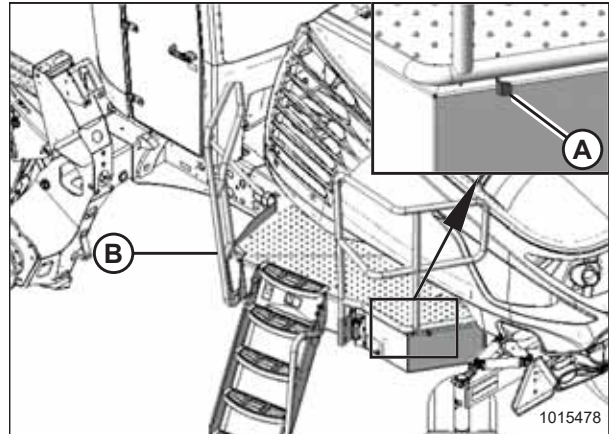

Figure 6.6: Left Platform

10. Pull platform (A) toward the cab until it stops and the latch is engaged.
11. Calibrate the header on the windrower. For instructions, refer to [6.2.4 Calibrating M2 Series Windrower and Header on HarvestTouch™ Display, page 80](#).

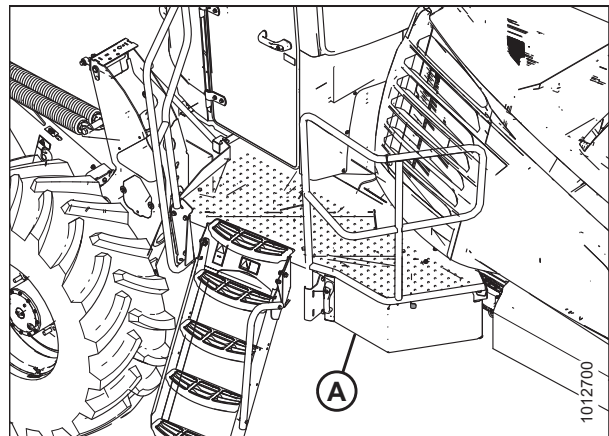

Figure 6.7: Left Platform

6.2 Connecting Header Hydraulic and Electrical Systems – M2260 Windrower

The header's electrical and hydraulic systems must be connected to the windrower. The procedure for connecting the header's hydraulic and electrical systems to the windrower differs depending on the configuration of the windrower.

IMPORTANT:

The Low Pressure Case Drain kit (B6698) must be installed on the M2260 Windrower before an R113 Rotary Disc Header can be connected.

The procedure for connecting the header's hydraulic connections to the windrower depends on the windrower's configuration:

- Auger/rotary disc/drapper header-ready windrowers are equipped with a set of hydraulic quick couplers which are compatible with the header drive hoses on the rotary disc header.
- Rotary disc header-ready windrowers are equipped with hard-plumbed hydraulic connections.

NOTE:

The hydraulic bundle includes a complete set of quick couplers that can be installed onto a windrower configured for use with rotary disc headers.

Proceed to the relevant procedure:

For auger/rotary disc/drapper-ready configuration (A), refer to [6.2.1 Auger/Rotary Disc/Draper-Ready Configuration – Quick Coupler Connections, page 72](#) for instructions.

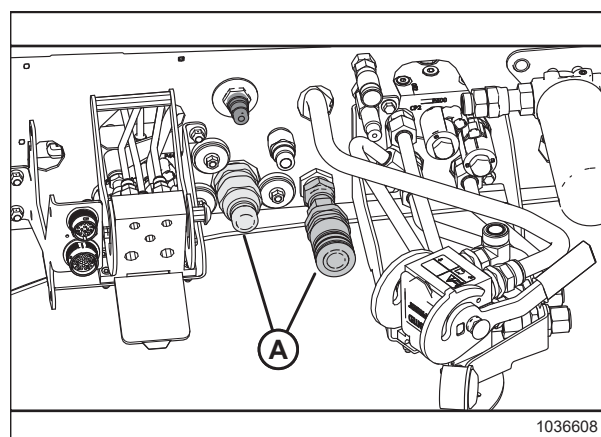

Figure 6.8: Header Hydraulics Configurations – Auger/Rotary Disc/Draper-Ready

For rotary disc-only hard-plumbed configuration (A), refer to [6.2.2 Rotary Disc-Only Configuration – Hard-Plumbed Fittings, page 75](#) for instructions.

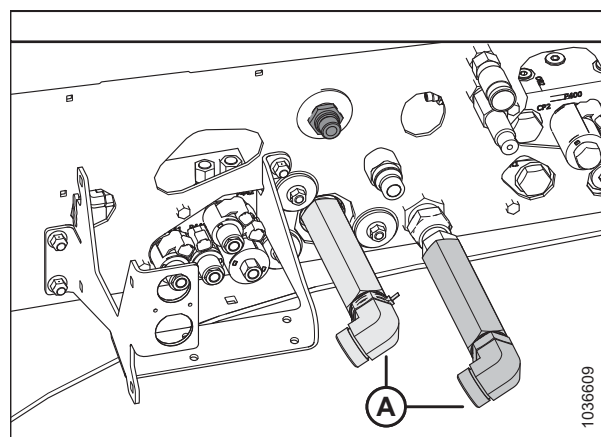

Figure 6.9: Header Hydraulics Configuration – Rotary Disc-Ready with Hard-Plumbed Connections

ATTACHING HYDRAULIC AND ELECTRICAL COMPONENTS

For rotary disc-ready configuration with quick couplers (A), refer to [6.2.3 Rotary Disc-Only Configuration – Quick Coupler Connections](#), page 77 for instructions.

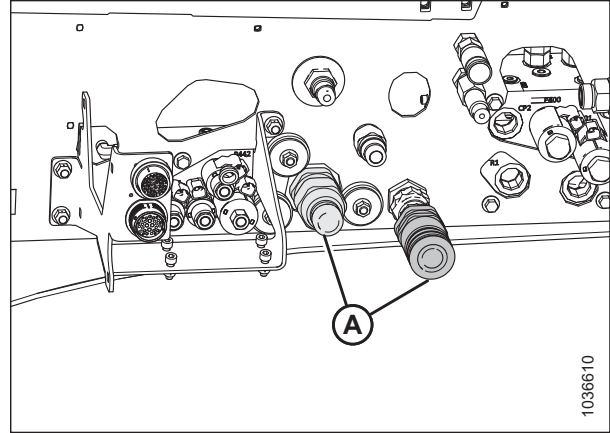

Figure 6.10: Header Hydraulics Configuration – Rotary Disc-Ready with Quick Couplers

6.2.1 Auger/Rotary Disc/Draper-Ready Configuration – Quick Coupler Connections

Windrowers with the auger/rotary disc/draper-ready configuration are equipped with the hydraulic connections needed to pair with an auger, rotary disc, or a draper header.

DANGER

To prevent bodily injury or death from the unexpected start-up of the machine, always stop the engine and remove the key from the ignition before making adjustments to the machine.

CAUTION

Do NOT stand on an unlocked platform. It is unstable and may cause you to fall.

IMPORTANT:

To prevent contamination of the hydraulic system, use a clean rag to remove dirt and moisture from all (fixed and movable) hydraulic couplers.

1. Shut down the engine, and remove the key from the ignition.
2. Approach platform (A) on the left side of the windrower. Ensure that the cab door is closed.
3. Push latch (B) and pull platform (A) toward the walking beam until it stops and the latch engages.

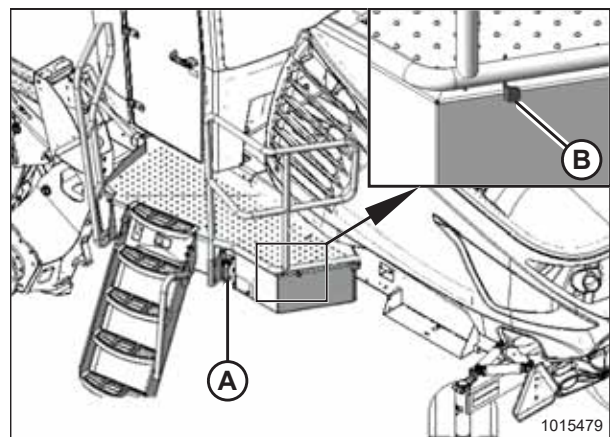

Figure 6.11: Left Platform

ATTACHING HYDRAULIC AND ELECTRICAL COMPONENTS

- Attach hose support (A) to the frame near the windrower left cab-forward leg. Route the hoses under the frame.

NOTE:

Ensure that the hoses remain as straight as possible and that they are not subject to damage from abrasion.

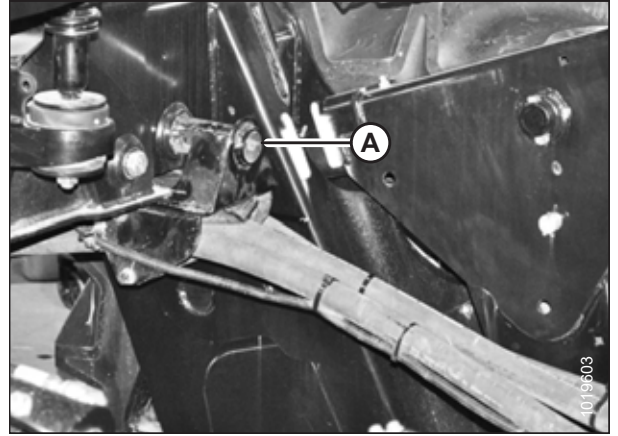

Figure 6.12: Hose Support Attachment

- Ensure that hose (A) is disconnected from windrower receptacle (B) and placed in storage cup (C) on the multicoupler.

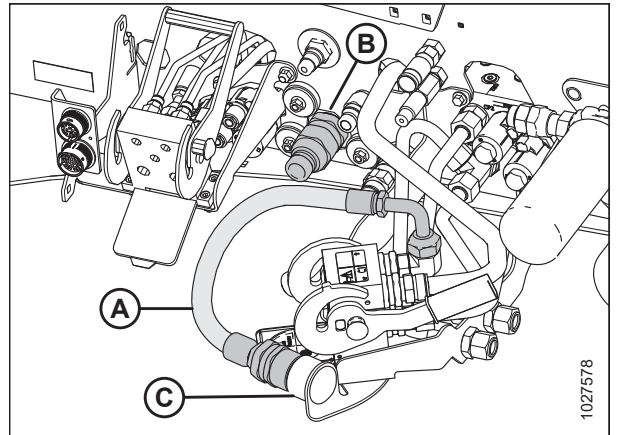

Figure 6.13: Couplers – Auger/Rotary/Draper Header-Ready Configuration with Case Drain Kit Installed

- Remove the extra hydraulic quick couplers from pressure hose (A) and return hose (B). These can be stored and used as replacement parts.

NOTE:

It is normal to have an extra set of quick couplers on windrowers with the auger/rotary disc/draper-ready configuration.

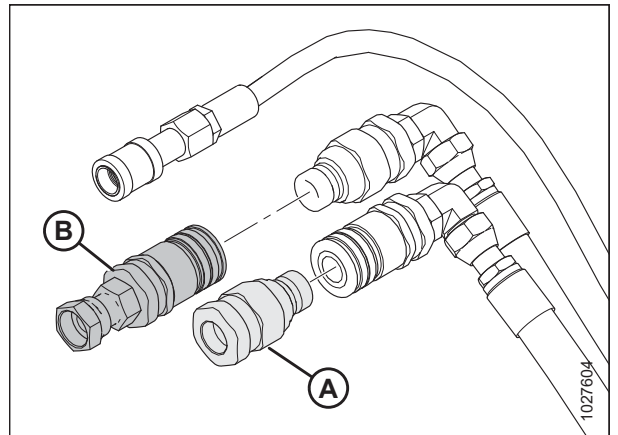

Figure 6.14: Hydraulic Quick Couplers

ATTACHING HYDRAULIC AND ELECTRICAL COMPONENTS

7. Connect the hydraulic hoses to the windrower with the quick coupler fittings as follows:
 - a. Connect the pressure hose female coupler to receptacle (A).
 - b. Connect the return hose male coupler to receptacle (B).
 - c. Connect case drain hose (C) to the mating 1/2 in. coupler on the frame.

NOTE:

This coupler is only present if the Low Pressure Case Drain kit (B6698) has been installed.

IMPORTANT:

Do **NOT** connect the case drain coupler to 1/2 in. flat faced coupler (E).

- d. Connect the electrical harness to receptacle (D).
8. Push latch (A) to unlock platform (B).

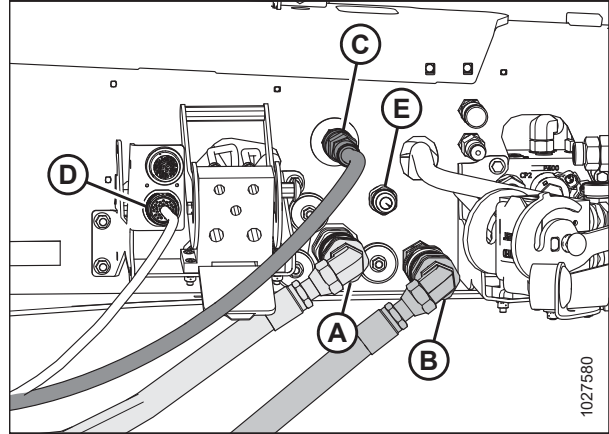

Figure 6.15: Hydraulics and Electrical Installed – Auger/Rotary/Draper-Ready Windrower

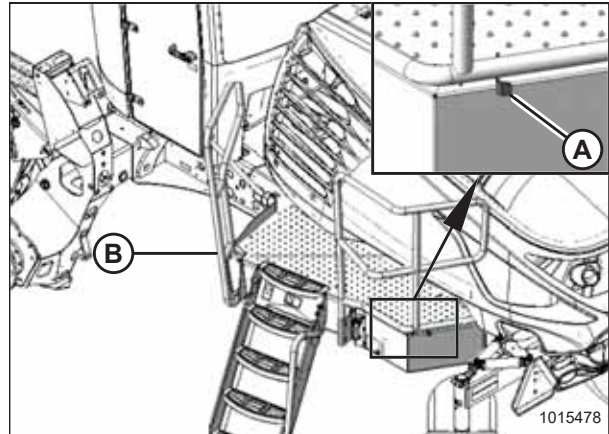

Figure 6.16: Left Platform

9. Pull platform (A) toward the cab until it stops and the latch is engaged.
10. Calibrate the header on the windrower. For instructions, refer to [6.2.4 Calibrating M2 Series Windrower and Header on HarvestTouch™ Display, page 80](#).

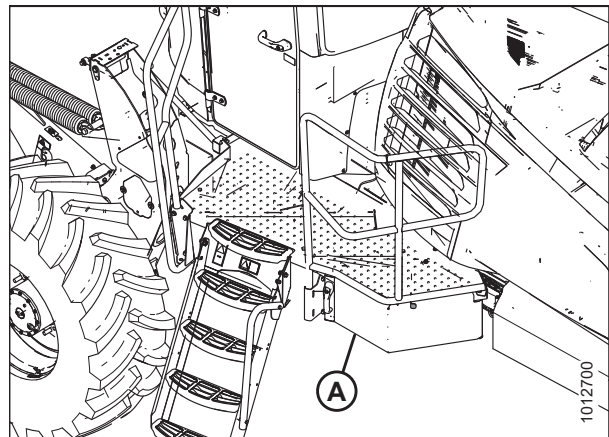

Figure 6.17: Left Platform

6.2.2 Rotary Disc-Only Configuration – Hard-Plumbed Fittings

The rotary disc-only configuration allows the windrower to operate with compatible rotary disc headers.

DANGER

To prevent bodily injury or death from the unexpected start-up of the machine, always stop the engine and remove the key from the ignition before making adjustments to the machine.

CAUTION

Do NOT stand on an unlocked platform. It is unstable and may cause you to fall.

IMPORTANT:

To prevent contamination of the hydraulic system, use a clean rag to remove dirt and moisture from all (fixed and movable) hydraulic couplers.

1. Shut down the engine, and remove the key from the ignition.
2. Approach platform (A) on the left side of the windrower. Ensure that the cab door is closed.
3. Push latch (B) and pull platform (A) toward the walking beam until it stops and the latch engages.

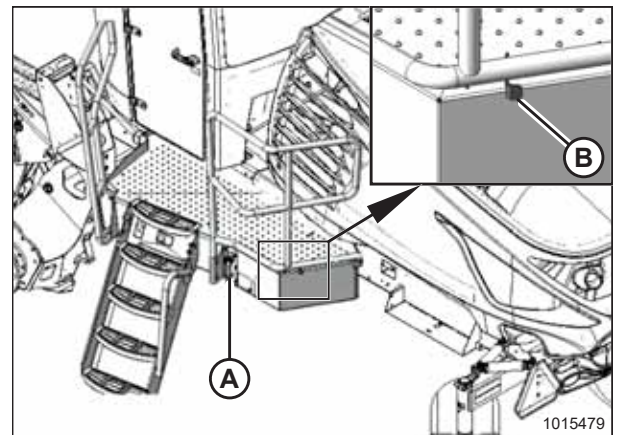

Figure 6.18: Left Platform

4. Attach hose support (A) to the frame near the windrower left cab-forward leg. Route the hoses under the frame.

NOTE:

Ensure that the hoses remain as straight as possible and that they are not subject to damage from abrasion.

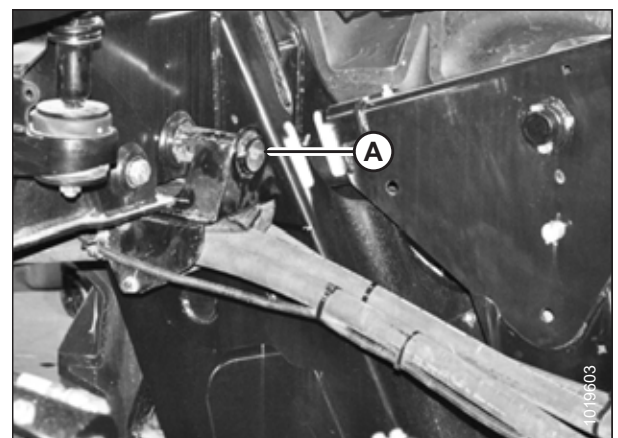

Figure 6.19: Hose Support Attachment

ATTACHING HYDRAULIC AND ELECTRICAL COMPONENTS

5. Remove the existing quick couplers and elbow fittings (if they are installed) from header hydraulic pressure hose (A) and return hose (B). Do **NOT** remove the fittings from case drain hose (C).

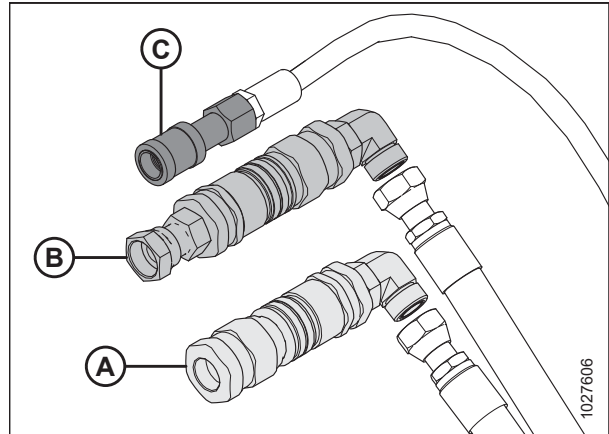

Figure 6.20: Rotary Disc Header Hose Bundle

6. Connect the hydraulic hoses to the windrower as follows:
 - a. Connect rotary disc pressure hose (A) as shown and torque it to 215 Nm (159 lbf-ft).
 - b. Connect rotary disc return hose (B) as shown and torque it to 215 Nm (159 lbf-ft).
 - c. Connect case drain hose (C) to the mating 1/2 in. coupler as shown.

NOTE:

The case drain hose coupler will be present only if the Low Pressure Case Drain kit (B6698) has been installed.

IMPORTANT:

Ensure that the case drain hose is connected to port (C), **NOT** port (E).

- d. Connect the electrical harness to receptacle (D).
7. Push latch (A) to unlock platform (B).

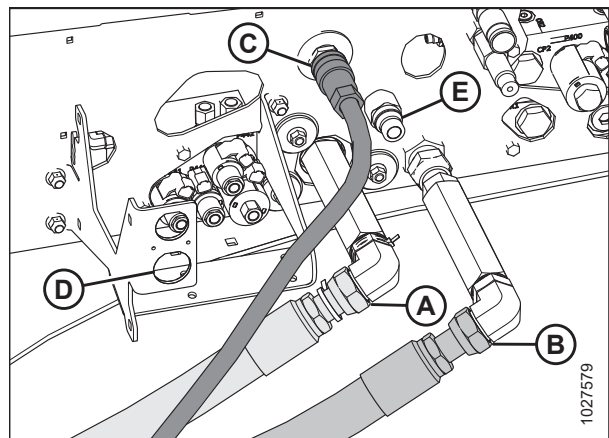

Figure 6.21: Hard Plumbed Connections on Disc Header-Ready Windrower with Case Drain Kit

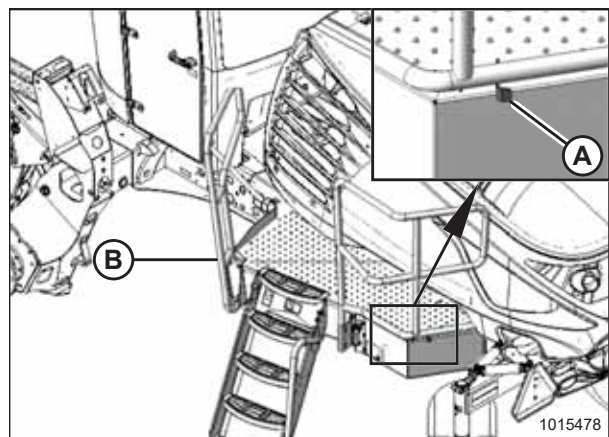

Figure 6.22: Left Platform

ATTACHING HYDRAULIC AND ELECTRICAL COMPONENTS

8. Pull platform (A) toward the cab until it stops and the latch is engaged.
9. Calibrate the header on the windrower. For instructions, refer to [6.2.4 Calibrating M2 Series Windrower and Header on HarvestTouch™ Display, page 80](#).

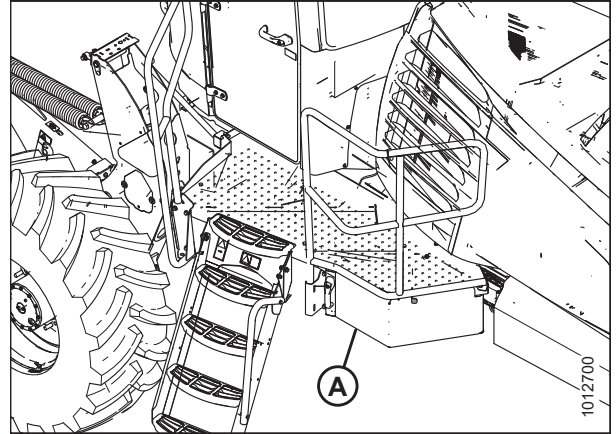

Figure 6.23: Left Platform

6.2.3 Rotary Disc-Only Configuration – Quick Coupler Connections

The rotary disc-only configuration allows the windrower to operate with compatible rotary disc headers. Attaching the header's hydraulic connections to the windrower's ports using quick couplers does not require any additional tools or hardware.

DANGER

To prevent bodily injury or death from the unexpected start-up of the machine, always stop the engine and remove the key from the ignition before making adjustments to the machine.

CAUTION

Do NOT stand on an unlocked platform. It is unstable and may cause you to fall.

IMPORTANT:

To prevent contamination of the hydraulic system, use a clean rag to remove dirt and moisture from all (fixed and movable) hydraulic couplers.

1. Shut down the engine, and remove the key from the ignition.
2. Approach platform (A) on the left side of the windrower. Ensure that the cab door is closed.
3. Push latch (B) and pull platform (A) toward the walking beam until it stops and the latch engages.

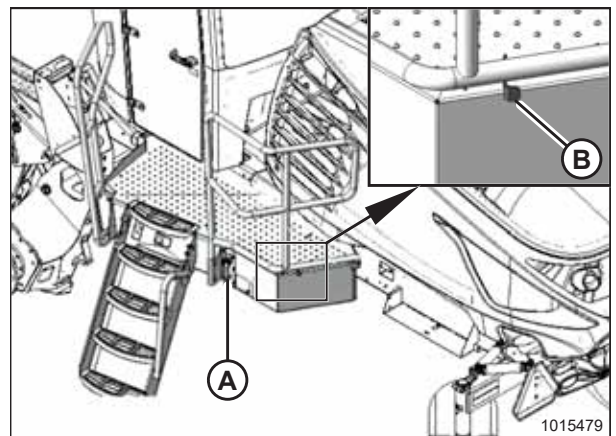

Figure 6.24: Left Platform

ATTACHING HYDRAULIC AND ELECTRICAL COMPONENTS

- Attach hose support (A) to the frame near the windrower left cab-forward leg. Route the hoses under the frame.

NOTE:

Ensure that the hoses remain as straight as possible and that they are not subject to damage from abrasion.

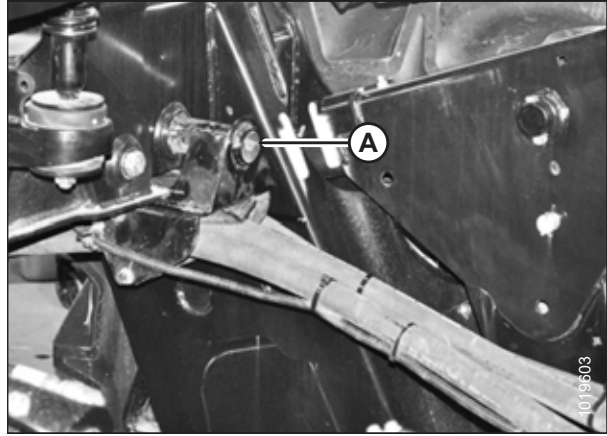

Figure 6.25: Hose Support Attachment

- Remove extension fittings and elbows (A) from the rotary disc header's hydraulic pressure and return connections.

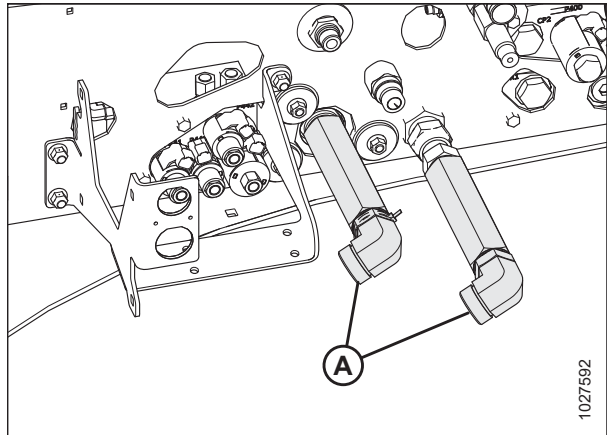

Figure 6.26: Hard Plumbed Connections – Rotary Disc-Ready Windrower

- Remove and retain the extra hydraulic quick couplers from pressure hose (A) and return hose (B).

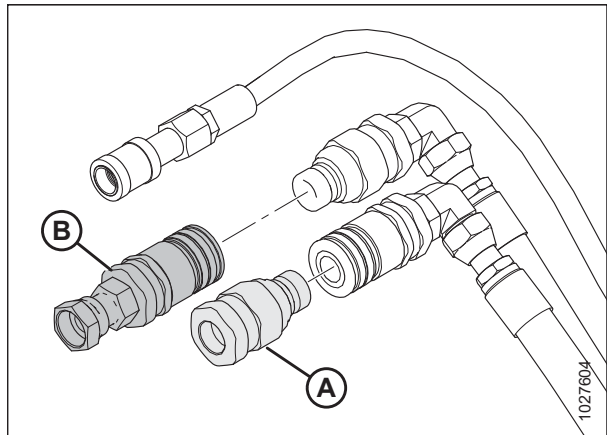

Figure 6.27: Hydraulic Quick Couplers

ATTACHING HYDRAULIC AND ELECTRICAL COMPONENTS

7. Install the male quick coupler at windrower pressure receptacle (A) as shown.
8. Install the female quick coupler at windrower return receptacle (B) as shown.

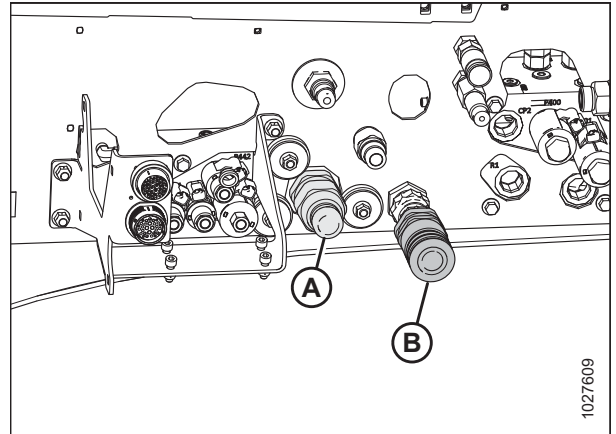

Figure 6.28: Quick Couplers on Rotary Disc-Ready Windrower

9. Connect the hydraulic hoses to the windrower as follows:
 - a. Connect pressure hose female coupler (A) as shown.
 - b. Connect return hose male coupler (B) as shown.
 - c. Connect case drain hose (C) as shown.

NOTE:

The case drain hose coupler will be present only if the Low Pressure Case Drain kit (B6698) has been installed.

IMPORTANT:

Ensure that the case drain hose is connected to port (C), **NOT** port (E).

- d. Connect the header's electrical harness to receptacle (D).

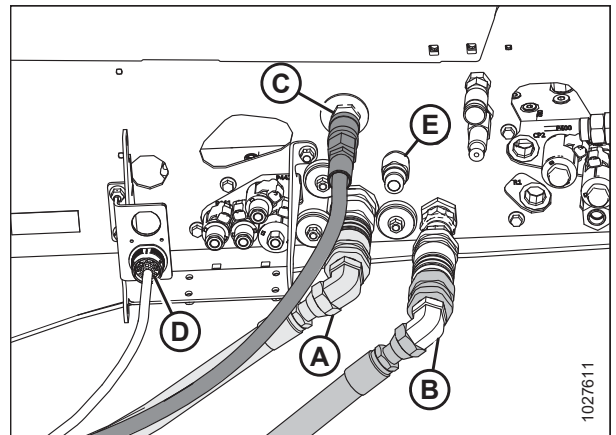

Figure 6.29: Quick Couplers on Rotary Disc-Ready Windrower with Case Drain Kit

10. Push latch (A) to unlock platform (B).

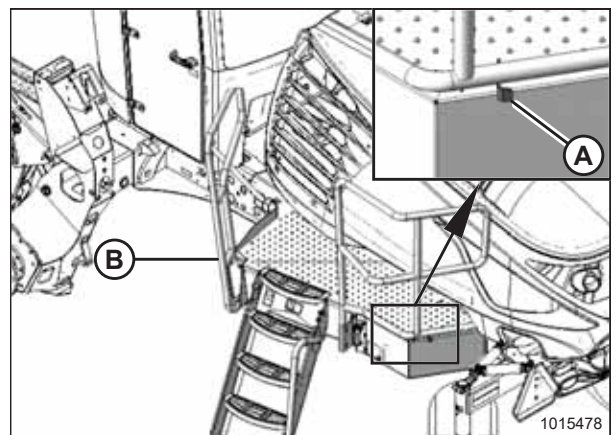

Figure 6.30: Left Platform

ATTACHING HYDRAULIC AND ELECTRICAL COMPONENTS

11. Pull platform (A) toward the cab until it stops and the latch is engaged.
12. Calibrate the header on the windrower. For instructions, refer to [6.2.4 Calibrating M2 Series Windrower and Header on HarvestTouch™ Display](#), page 80.

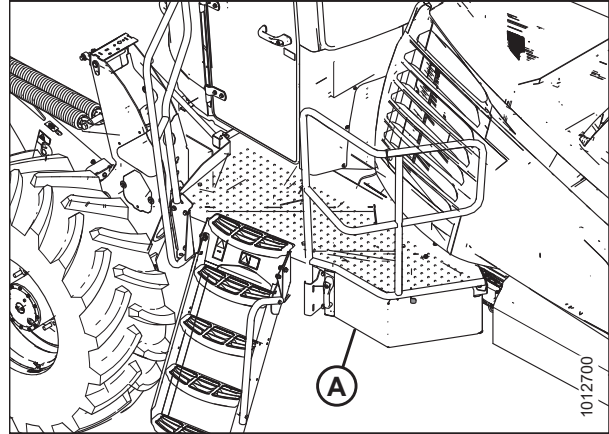

Figure 6.31: Left Platform

6.2.4 Calibrating M2 Series Windrower and Header on HarvestTouch™ Display

The HarvestTouch™ Display recognizes when a header is attached to the windrower and determines which systems will require calibration.

The following sensors may require calibration, depending on the type of header attached to the windrower:

- Header height
- Header angle
- Header float left
- Header float right
- Reel height
- Reel fore-aft
- Swath compressor
- Knife drive

Refer to the following topics for information on calibrating header systems:

- [Calibrating Knife Drive on HarvestTouch™ Display – M2 Series Windrowers](#), page 80
- [Calibrating Header Position Sensors on HarvestTouch™ Display](#), page 84

Calibrating Knife Drive on HarvestTouch™ Display – M2 Series Windrowers

When a header is attached to the windrower, the windrower's HarvestTouch™ Display will recognize the header ID and choose the appropriate settings for that header. Before it can be operated, however, the header's knife drive must be calibrated to ensure that the knife drive pump output is accurate.

DANGER

Ensure that all bystanders have cleared the area.

NOTE:

This calibration **MUST** be performed with the engine running and the header engaged.

ATTACHING HYDRAULIC AND ELECTRICAL COMPONENTS

1. Start the engine.
2. Engage the header.

NOTE:

Once the header is engaged, header gauges (A) will appear on the HarvestTouch™ Display home page.

3. Select MENU icon (B).

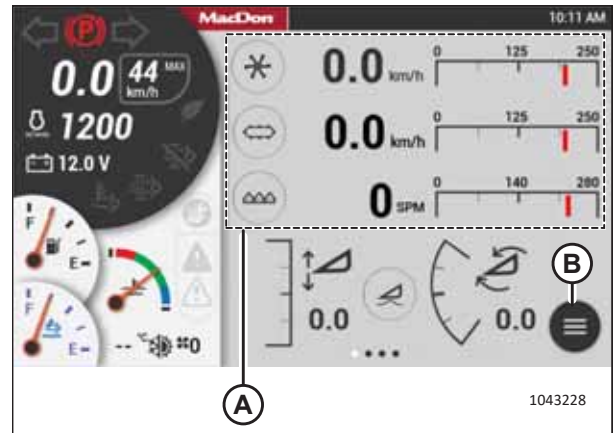

Figure 6.32: HarvestTouch™ Display

4. Select SETUP (A).

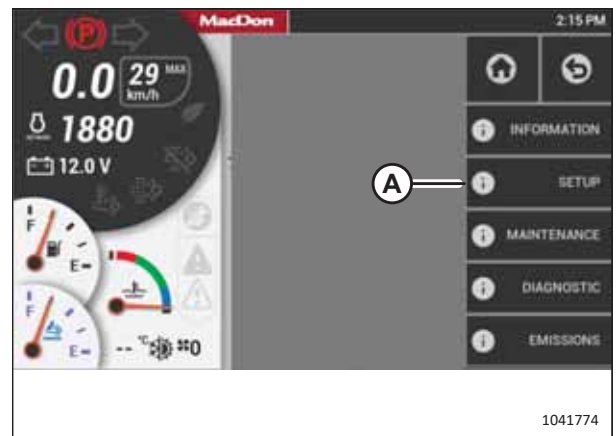

Figure 6.33: Main Menu

5. Select WINDROWER (A).



Figure 6.34: Setup Menu

ATTACHING HYDRAULIC AND ELECTRICAL COMPONENTS

6. Select CALIBRATION (A).

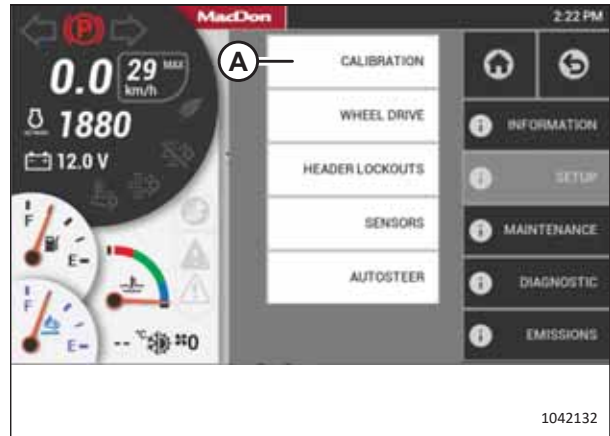

Figure 6.35: Setup Menu

7. Select KNIFE DRIVE (A).



Figure 6.36: Calibration Selection Page

8. Select PLAY icon (A).

NOTE:

The PLAY icon will only appear if the header is engaged.

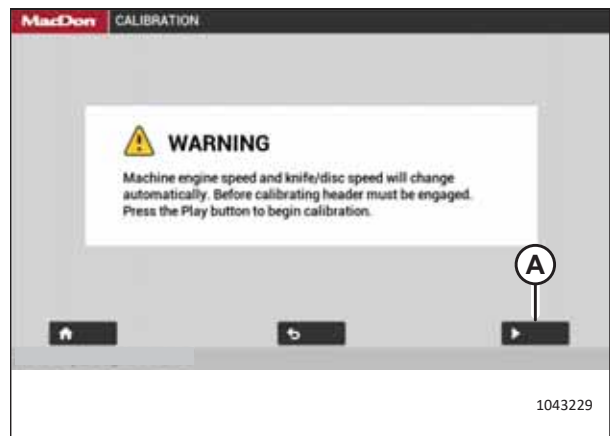

Figure 6.37: Engage Header Warning

ATTACHING HYDRAULIC AND ELECTRICAL COMPONENTS

9. The display changes to show that calibration has started. The process should automatically proceed through all nine stages.

NOTE:

If the engine speed is less than 1500 rpm before calibration, the system will raise the engine speed to 1500 rpm.

NOTE:

During the calibration process, the speed of the header and the engine will fluctuate.

NOTE:

Select X icon (A) on the screen or use the HEADER DISENGAGE switch at any time during the calibration process to exit the procedure without saving your progress. The engine will resume the speed at which it was operating before the calibration process began.

NOTE:

If error message (A) appears during the calibration process, follow the instructions in the message to fix the error. Select X icon (B) to exit the message. If the knife calibration process fails:

- Confirm that the engine and the hydraulics are at operating temperature.
- Confirm that the hydraulic system is free of any restrictions and is in working order.
- Confirm that the throttle is working:
 - Check the engine codes to confirm that the engine is not derated or throttle-inhibited.
 - The throttle is controlled via the powertrain’s CAN network 1. Check the network’s wiring and connectors for an open or intermittent connection.
- Confirm that the sensor mounting is secured properly and that the sensor’s gap is set correctly.
- Check the sensor wiring and connectors for an intermittent connection.
- Replace the sensor.



Figure 6.38: Calibration Page

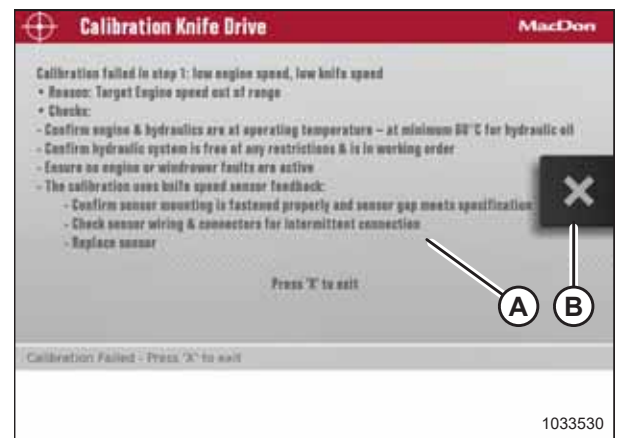

Figure 6.39: Calibration Page

ATTACHING HYDRAULIC AND ELECTRICAL COMPONENTS

- Once the calibration process completes all nine stages, the message CALIBRATING COMPLETED appears. Select X icon (A) to exit the page.

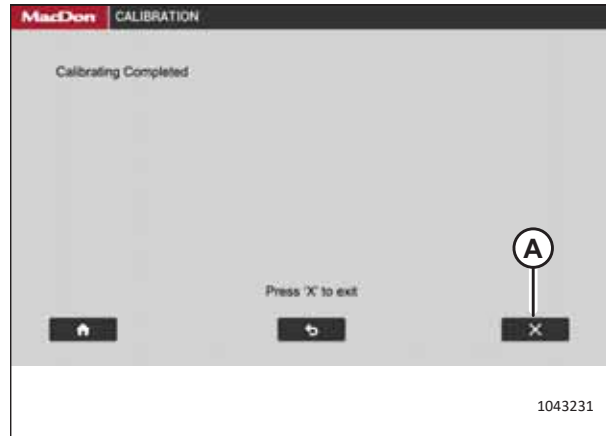

Figure 6.40: Calibration Page

Calibrating Header Position Sensors on HarvestTouch™ Display

The header position sensors need to be recalibrated whenever the HarvestTouch™ Display is replaced, a position sensor is replaced, sensor readouts are erratic, a pump has been replaced, or when a new header type or attachment is connected to the windrower.

DANGER

Ensure that all bystanders have cleared the area.

NOTE:

This calibration **MUST** be performed with the engine running and the header engaged.

- Start the engine.
- Engage the header.

NOTE:

Once the header is engaged, header gauges (A) will appear on the HarvestTouch™ Display home page.

- Select MENU icon (B).

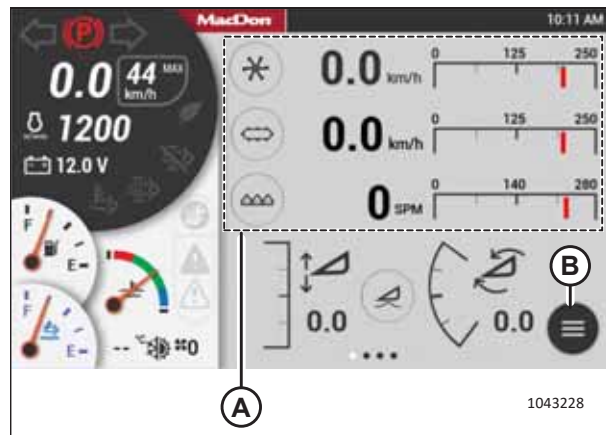

Figure 6.41: HarvestTouch™ Display

ATTACHING HYDRAULIC AND ELECTRICAL COMPONENTS

4. Select SETUP (A).

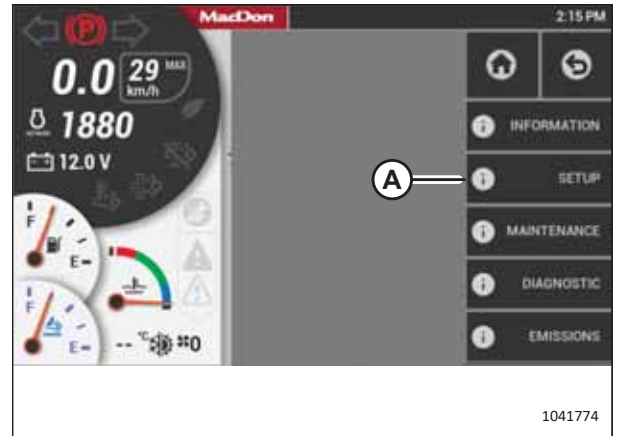

Figure 6.42: Main Menu

5. Select CALIBRATION (A).

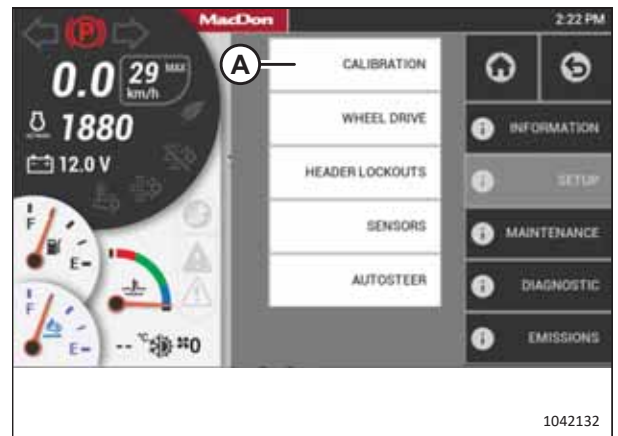

Figure 6.43: Setup Menu

6. Select POSITION (A).

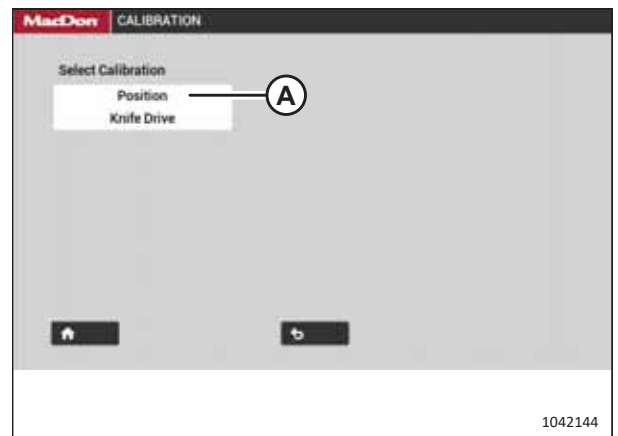

Figure 6.44: Calibration Selection Page

ATTACHING HYDRAULIC AND ELECTRICAL COMPONENTS

7. Select PLAY icon (A).

NOTE:

The PLAY icon will only appear if the header is engaged.



Figure 6.45: Engage Header Warning

8. The calibration will attempt the first calibration stage.

NOTE:

Selecting X icon (A), HOME, or BACK, or pressing any of the ground speed lever (GSL) buttons at any time during calibration will EXIT the calibration process without saving your progress. The engine speed will return to the original rpm before starting the calibration process.

NOTE:

If a sensor goes out of its normal operating range during the calibration process, calibration will stop and a message will appear on the screen indicating that a sensor is out of range.



Figure 6.46: Calibration Page

9. When the first stage of the calibration is complete, select PLAY icon (A) on the screen to continue with the second stage of the calibration process.

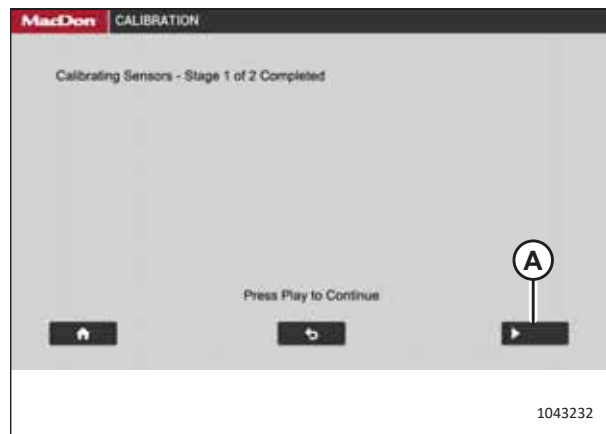

Figure 6.47: Calibration Page

ATTACHING HYDRAULIC AND ELECTRICAL COMPONENTS

NOTE:

If the voltage of any sensor falls below its acceptable range during calibration, a message appears afterward with a list of sensors reporting out-of-range voltages. Adjust the sensors as needed and repeat the calibration process from the beginning.



Figure 6.48: Sample of Failed Calibration Display Message

- When the second stage of calibration is complete, calibration is complete. Select RESUME icon (A) on the screen to configure the HEADER FLOAT setting, or select the HOME or BACK icons to exit the screen.

NOTE:

The engine speed returns to the speed prior to calibration when the second stage of the calibration is complete.

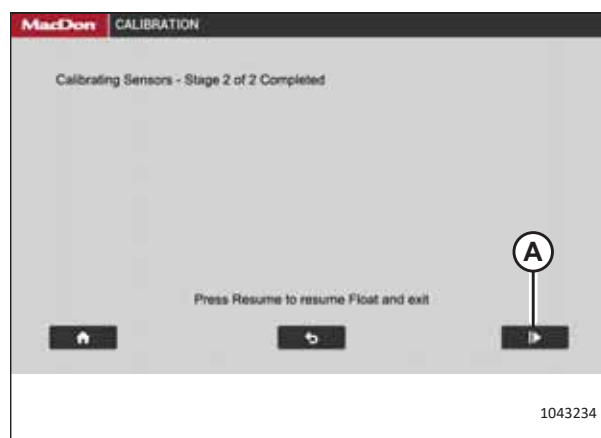

Figure 6.49: Calibration Page

6.3 Connecting Header Hydraulic and Electrical Systems – M1240 Windrower

Connect the header hydraulic and electrical components to the windrower in order to operate the header.

IMPORTANT:

Install the M1240 Low Pressure Case Drain kit (B6698) prior to connecting the hydraulic components.

The header hydraulics connection procedure varies depending on the windrower configuration:

- Draper header ready windrowers include one set of hydraulic quick couplers which are compatible with the header drive hoses on the R113 Rotary Disc Header.
- Rotary disc header ready windrowers include hard plumbed hydraulics connections.

IMPORTANT:

To prevent contamination of the hydraulic system, use a clean rag to remove dirt and moisture from all (fixed and movable) hydraulic couplers.

NOTE:

The header hydraulic bundle includes a complete set of quick couplers that can be installed onto a rotary disc header configured windrower.

1. Open the windrower's left platform. For instructions, refer to the windrower operator's manual.
2. Using a clean rag, remove dirt and moisture from the couplers on the left side of the windrower frame.
3. Retrieve hydraulic hoses (A) from the header and route the hose bundle under the windrower frame.
4. Insert pin (B) into hole (C) in the windrower frame.

IMPORTANT:

Route hydraulic hoses as straight as possible, and avoid rub/wear points that could damage the hoses. To prevent damage, the hoses should have enough slack to pass by the multicoupler bracket without contact. To adjust hose slack, loosen the clamps below pin (B), adjust the hoses, then retighten the hose holder.

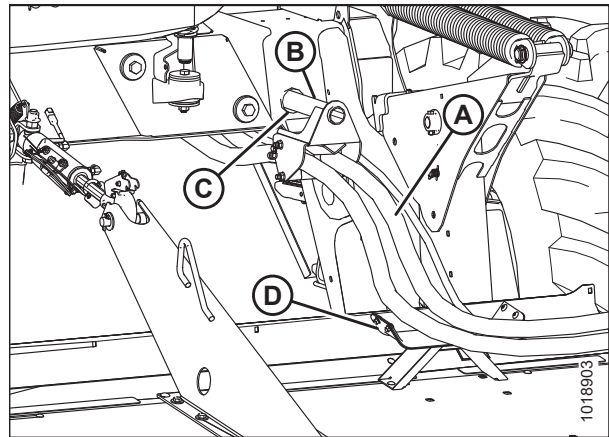

Figure 6.50: Hose Support Attachment

ATTACHING HYDRAULIC AND ELECTRICAL COMPONENTS

Proceed with the steps that are relevant to the following windrower configurations:

Windrower Configuration	Steps for Connecting Hydraulics and Electrical
Rotary disc/drafter ready configuration (A)	Step 5, page 89 to Step 7, page 90
Rotary disc only hard plumbed configuration (B)	Step 8, page 90 to Step 9, page 91 Step
Rotary disc ready configuration (B) with quick couplers installed	Steps 10, page 91 to 14, page 92

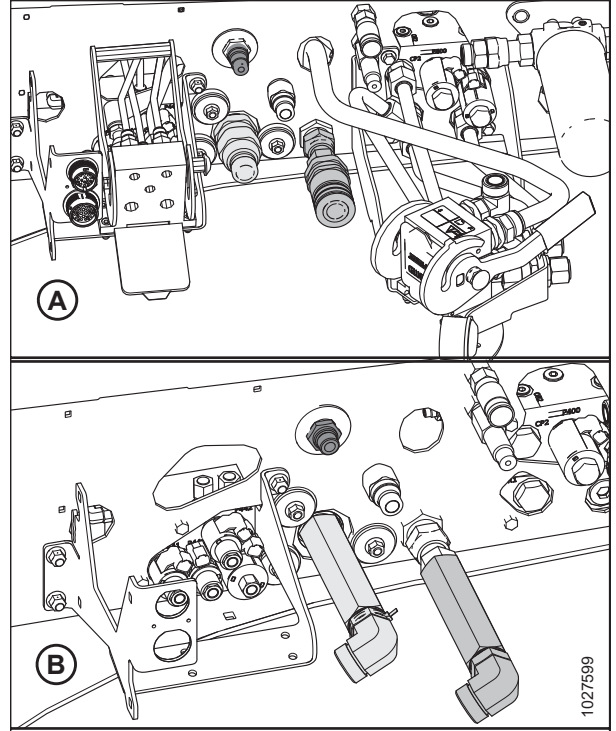

Figure 6.51: Header Hydraulics Configurations

Rotary disc/drafter ready configuration with quick couplers:

5. Ensure hose (A) is disconnected from windrower receptacle (B) and placed in storage cup (C) on multicoupler.

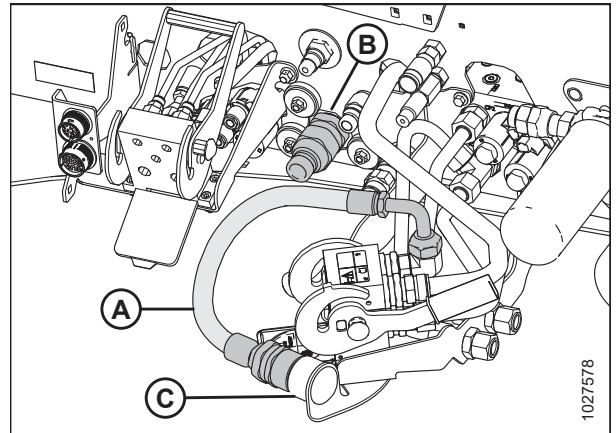

Figure 6.52: Couplers – Drafter Ready

ATTACHING HYDRAULIC AND ELECTRICAL COMPONENTS

6. Remove the extra hydraulic quick couplers from pressure hose (A) and return hose (B) and store them as spares.

NOTE:

It is normal to have an extra set of quick couplers with the rotary disc/drapper ready configuration.

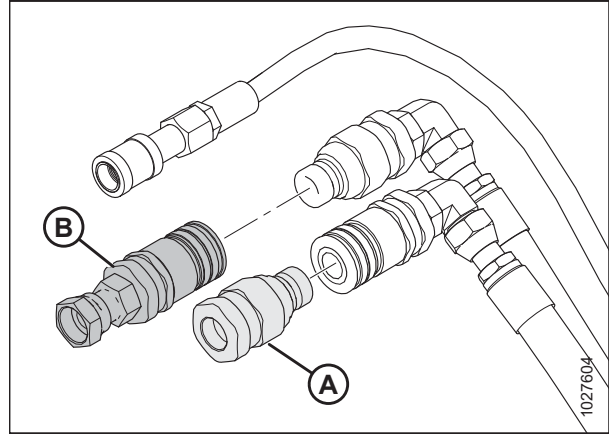

Figure 6.53: Hydraulic Quick Couplers

7. Connect the hydraulic hoses to the windrower with quick coupler fittings as follows:
 - a. Connect pressure hose female coupler to receptacle (A).
 - b. Connect return hose male coupler to receptacle (B).
 - c. Connect case drain hose (C) to mating 1/2 in. coupler on frame—installed with the M1240 Low Pressure Case Drain kit (B6698). The other 1/2 in. flat faced coupler for case drain (E) is **NOT** suitable for the R113 Rotary Disc Header.
 - d. Connect the electrical harness to receptacle (D).

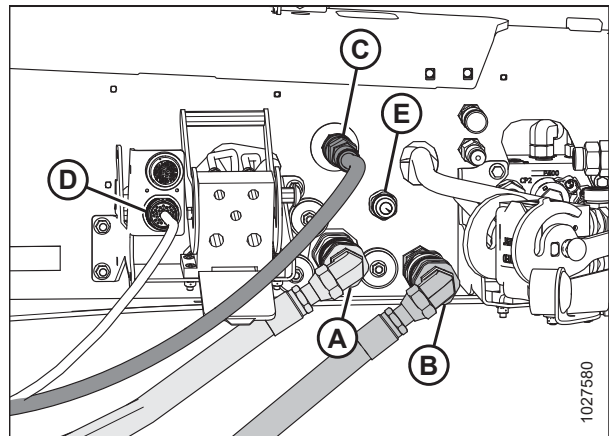

Figure 6.54: Hydraulics and Electrical – Draper Ready Windrower

Hard plumbed fittings – rotary disc ready windrower:

8. If installed, remove the existing quick couplers and elbow fittings from header hydraulic pressure hose (A) and return hose (B). Do **NOT** remove fittings from case drain hose (C).

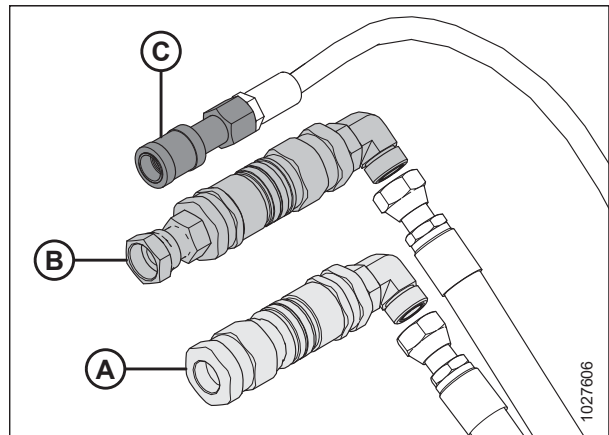

Figure 6.55: R113 SP Hose Bundle – Rotary Disc Ready Windrower

ATTACHING HYDRAULIC AND ELECTRICAL COMPONENTS

9. Connect the hydraulic hoses to the windrower with hard plumbed fittings as follows:
 - a. Connect rotary disc pressure hose (A) to fitting on frame and torque to 205–226 Nm (151–167 lbf-ft).
 - b. Connect rotary disc return hose (B) to fitting on frame and torque to 205–226 Nm (151–167 lbf-ft).
 - c. Connect case drain hose (C) to mating 1/2 in. coupler on frame—installed with the M1240 Low Pressure Case Drain kit (B6698). The other 1/2 in. flat faced coupler for case drain (E) is **NOT** suitable for the R113 Rotary Disc Header.
 - d. Connect the electrical harness to receptacle (D).

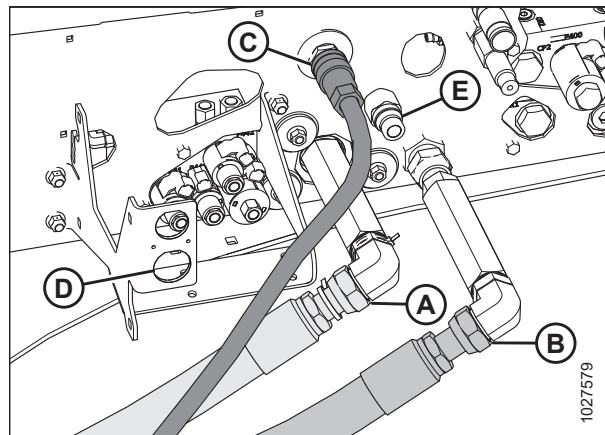

Figure 6.56: Hard Plumbed Connections on Disc Header Ready Windrower

Quick coupler fittings – rotary disc ready windrower:

10. Remove quick couplers from pressure hose (A) and return hose (B) on the R113 Rotary Disc Header hydraulic hose bundle.

NOTE:

Do **NOT** remove the fittings on the case drain hose that was installed with the M1240 Low Pressure Case Drain kit (B6698).

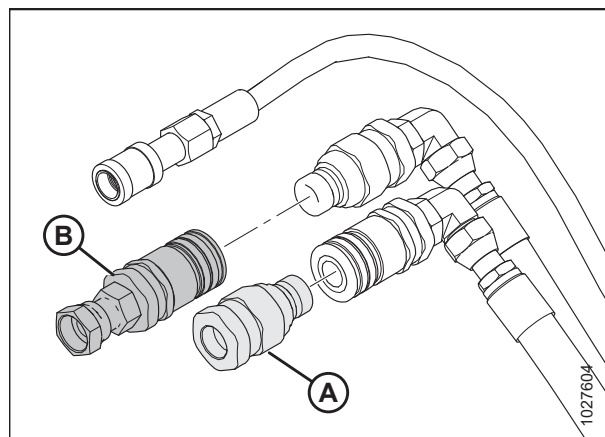

Figure 6.57: Hydraulic Quick Couplers

11. Remove the extension fittings and elbows (A) from the rotary disc header hydraulic pressure and return connections.

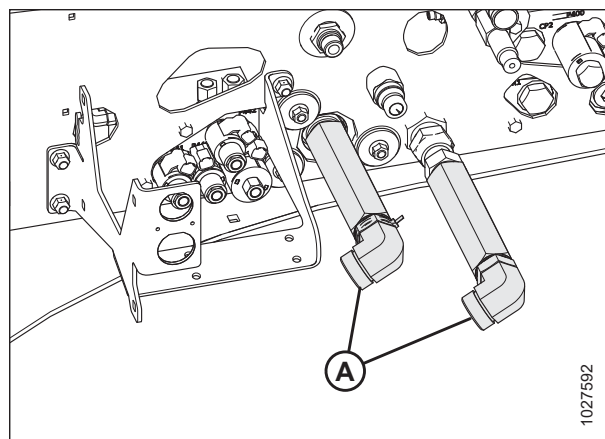

Figure 6.58: Hard Plumbed Connections – Rotary Disc Ready Windrower

ATTACHING HYDRAULIC AND ELECTRICAL COMPONENTS

12. Install the male quick coupler at windrower pressure receptacle (A).
13. Install the female quick coupler with adapter at windrower return receptacle (B).

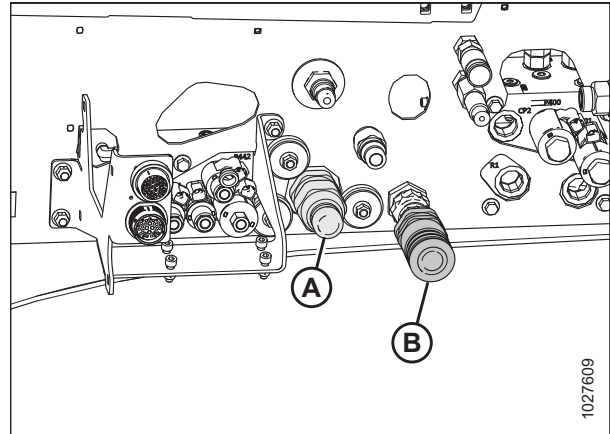

Figure 6.59: Quick Couplers on Rotary Disc Ready Windrower

14. Connect the hydraulic hoses to the windrower with quick connect fittings, as follows:
 - a. Connect pressure hose (A) female coupler to receptacle.
 - b. Connect return hose (B) male coupler to receptacle.
 - c. Connect case drain hose (C) to mating 1/2 in. coupler on frame—installed with the M1240 Low Pressure Case Drain kit (B6698). The other 1/2 in. flat faced coupler for case drain (E) is **NOT** suitable for the R113 Rotary Disc Header.
 - d. Connect the electrical harness to receptacle (D).

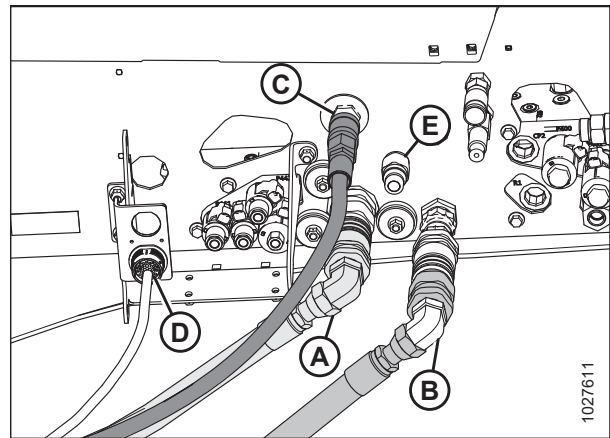

Figure 6.60: Quick Couplers on Rotary Disc Ready Windrower

15. Push latch (B) to unlock and close left side platform (A).

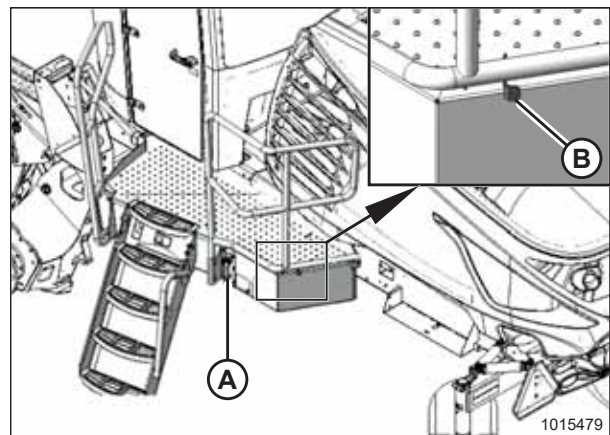

Figure 6.61: Left Cab-Forward Platform

ATTACHING HYDRAULIC AND ELECTRICAL COMPONENTS

16. Pull platform (A) toward the cab until it stops and the latch is engaged.
17. Calibrate the knife pump on the windrower. For instructions, refer to [6.4.1 Calibrating M1 Series Windrower Knife Drive and Header on Harvest Performance Tracker Display](#), page 97.

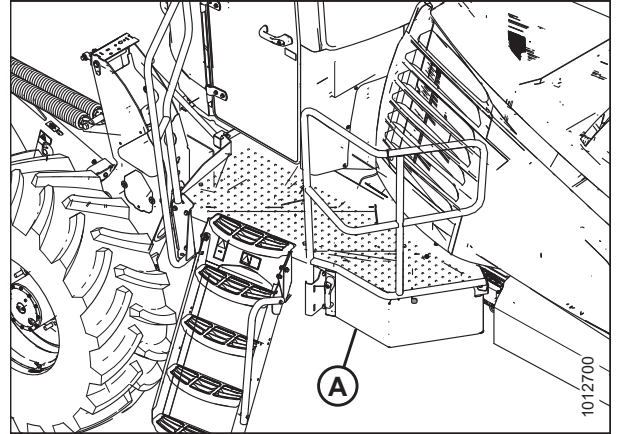

Figure 6.62: Left Platform

6.4 Connecting Header Hydraulic and Electrical Systems – M1170 Windrower

The header's hydraulic and electrical multicoupler will need to be connected to the windrower.

IMPORTANT:

To prevent contamination of the hydraulic system, use a clean rag to remove dirt and moisture from all (fixed and movable) hydraulic couplers.

1. Open the platform. For instructions, refer to the windrower operator's manual.
2. Retrieve the hydraulic hoses from the header.
3. Attach hose support (A) to the frame near the windrower left cab-forward leg, and route the hoses under the frame.

NOTE:

Route the hydraulic hoses as straight as possible, and avoid rub/wear points that could cause damage.

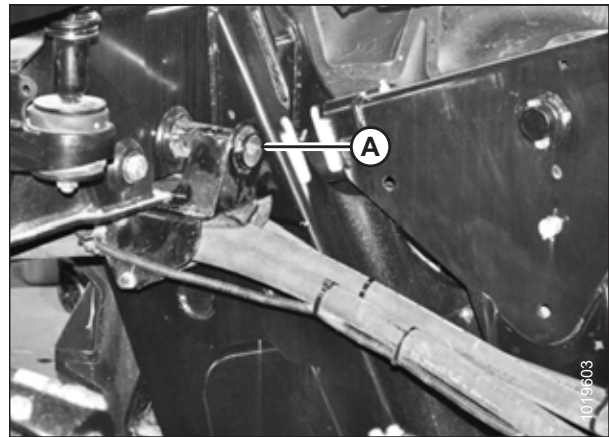

Figure 6.63: Hose Support Attachment

4. Disconnect male coupler (A) from the pressure hose.
5. Disconnect female coupler and fitting (B) from the return hose.

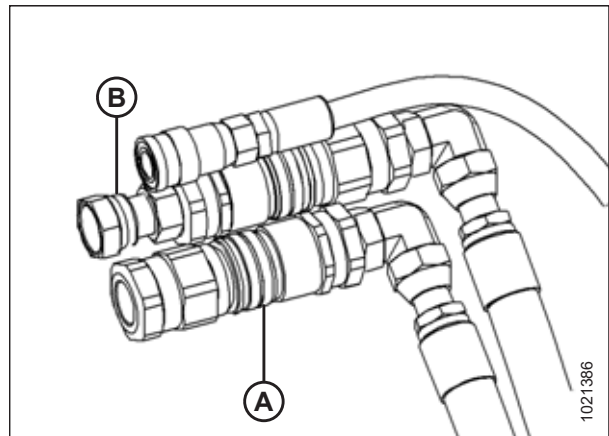

Figure 6.64: Hoses from Header

ATTACHING HYDRAULIC AND ELECTRICAL COMPONENTS

6. Remove coupling and cap (A) and plug (B) from fittings on the windrower.

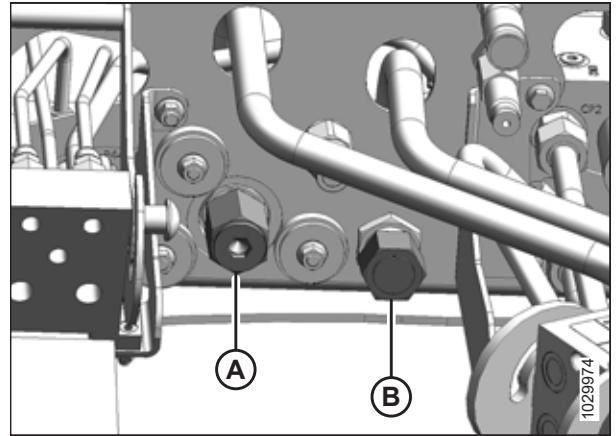

Figure 6.65: Windrower Hydraulics

7. Install the male coupler onto pressure fitting (A), and the female coupler onto return fitting (B) on the windrower.
8. Tighten the couplers onto the fittings.

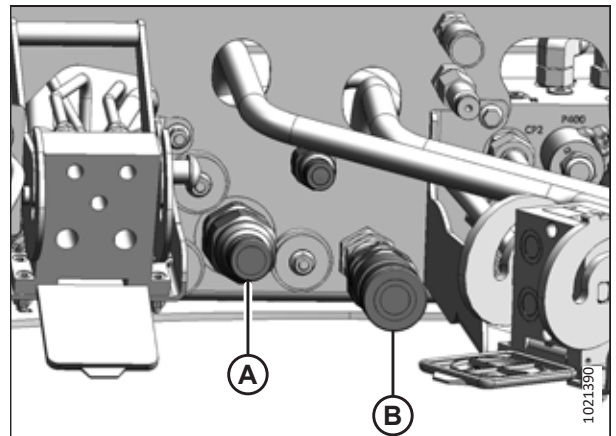

Figure 6.66: Couplers

9. Disconnect steel line (A) from elbow (B) and tee (C) (inside frame), and remove and discard the line.

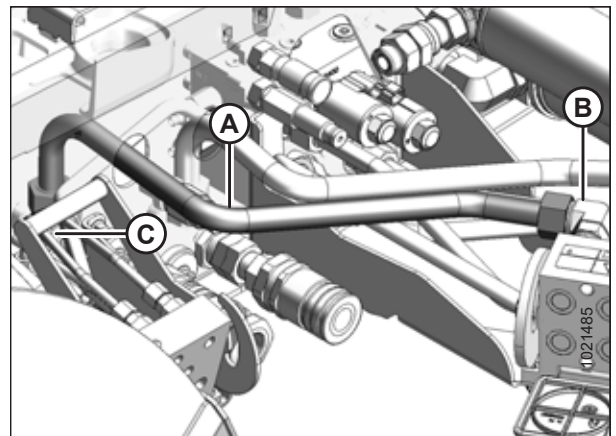

Figure 6.67: Windrower Couplers

ATTACHING HYDRAULIC AND ELECTRICAL COMPONENTS

10. Install cap (A) on tee.
11. Reposition elbow (B) as shown.

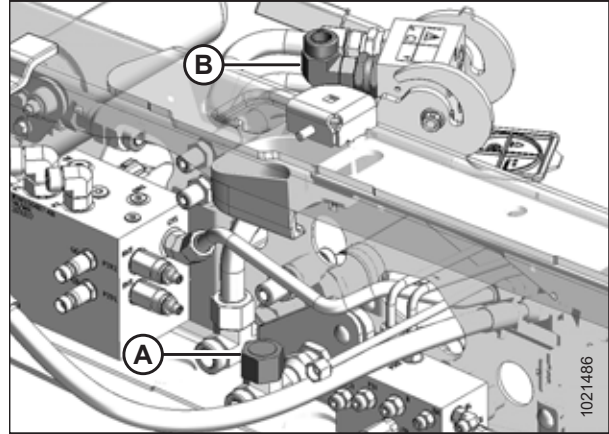

Figure 6.68: Windrower Header Drive

12. Remove two existing nuts (A) securing the multicoupler to bracket (B).
13. Position new bracket (C) onto the existing bolts and secure with existing nuts (A).
14. Install rubber coupler holder (D) into bracket (C).

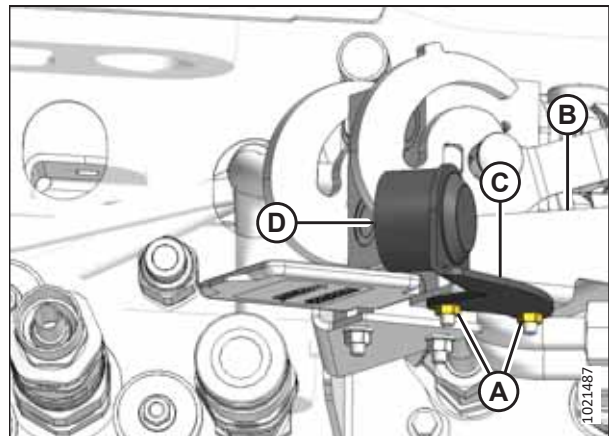

Figure 6.69: Windrower Couplers

15. Connect fitting (A) on the knife pressure hose to elbow fitting (B).
16. Place female coupler (C) on the knife pressure hose into holder (D).

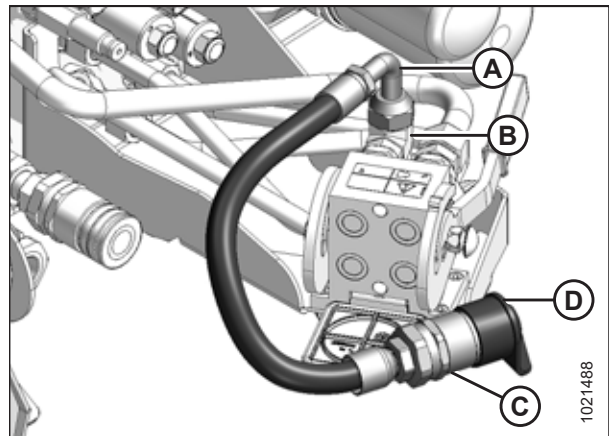

Figure 6.70: Windrower Coupler

ATTACHING HYDRAULIC AND ELECTRICAL COMPONENTS

17. Attach the couplers to receptacles on the windrower as follows:
 - a. Connect the pressure hose female coupler to receptacle (A)
 - b. Connect the return hose male coupler to receptacle (B)
 - c. Connect the case drain hose coupler to receptacle (C)
 - d. Connect the electrical harness to receptacle (D)

IMPORTANT:

The hydraulic hoses should have enough slack to pass by multicoupler (E) without coming into contact with it. This will protect the hoses from rubbing against the multicoupler and becoming damaged. You can increase slack in the hoses by loosening and adjusting the hose holder on the front windrower leg, and pulling the hoses backward toward the windrower.

18. Push latch (B) to unlock platform (A).
19. Close the platform. For instructions, refer to the windrower operator's manual.

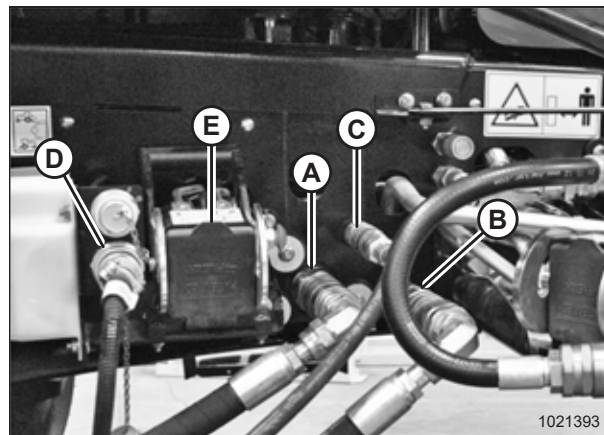

Figure 6.71: Hydraulic and Electrical Connections

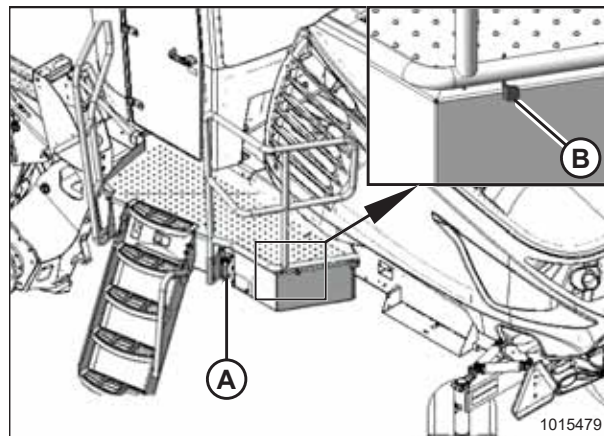

Figure 6.72: Left Cab-Forward Platform

6.4.1 Calibrating M1 Series Windrower Knife Drive and Header on Harvest Performance Tracker Display

When an R1 Series Rotary Disc Header is attached to an M1 Series Windrower, the Harvest Performance Tracker (HPT) will recognize the header ID. The header must be calibrated to ensure that the knife drive pump output is accurate.

DANGER

Before starting the machine, check to be sure all bystanders have cleared the area.

NOTE:

To calibrate the knife drive, the header must be attached and engaged. If the header is disengaged when calibration is selected, the message ENGAGE HEADER will appear on the screen.

ATTACHING HYDRAULIC AND ELECTRICAL COMPONENTS

1. Start the engine.
2. Press soft key 5 (A) to open the HPT main menu.

NOTE:

Calibrations **MUST** be performed with the engine running. Some calibrations will not be available with the engine off.

3. Use HPT scroll knob (B) or the ground speed lever (GSL) scroll wheel (not shown) to highlight SETTINGS icon (C).
4. Press HPT scroll knob (B) or the GSL SELECT button (not shown) to activate the settings menu options.

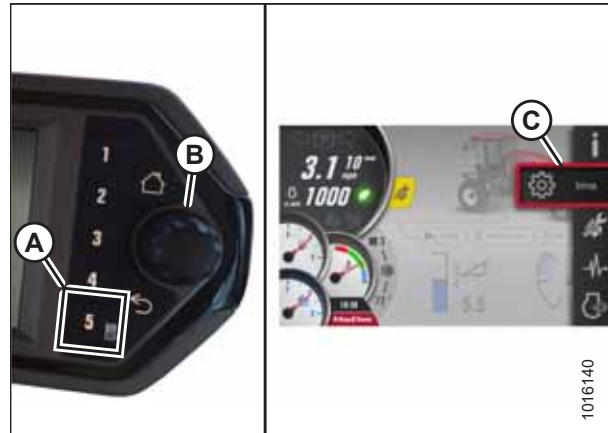

Figure 6.73: Opening the Main Menu

5. Scroll to WINDROWER icon (A) and press the HPT scroll knob.
6. Scroll to CALIBRATION icon (B), and press SELECT to open the CALIBRATION SELECTION page.

NOTE:

The F3 shortcut button on the operator's console will also open the WINDROWER SETTINGS menu.

7. Select KNIFE DRIVE.

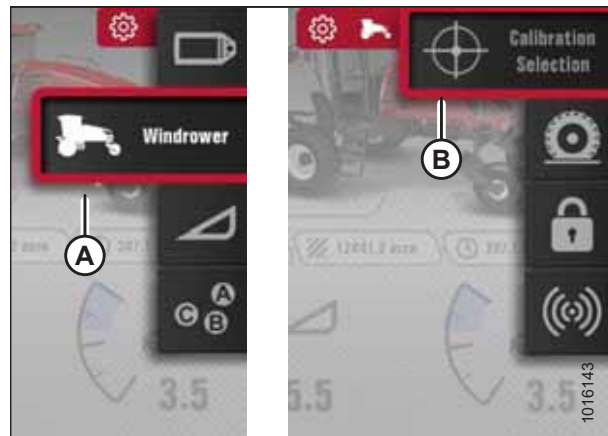

Figure 6.74: Windrower Icon and Calibration Selection Submenu Icon

8. Press the PLAY icon to begin the calibration process.

NOTE:

During the calibration sequence, the engine rpm and header speed will increase and decrease multiple times.

NOTE:

Press the X button (A) on the screen or use the HEADER DISENGAGE switch at any time during the calibration process to exit calibration without saving. The engine speed will return to the original rpm prior to starting the calibration process.



Figure 6.75: Calibration Page

6.5 Connecting Header Hydraulic and Electrical Systems – M155 or M155E4 Windrowers

The header's hydraulic and electrical multicoupler will need to be connected to the windrower.

DANGER

To avoid bodily injury or death from unexpected startup of the machine, always stop the engine and remove the key from the ignition before leaving the operator's seat for any reason.

NOTE:

M155 or M155E4 Windrowers require Disc Drive Manifold kit (B4657) to hydraulically connect an R113 Rotary Disc Header.

1. Disengage and rotate lever (A) counterclockwise to the FULLY-UP position.
2. Remove cap (B) securing the electrical connector to the frame.

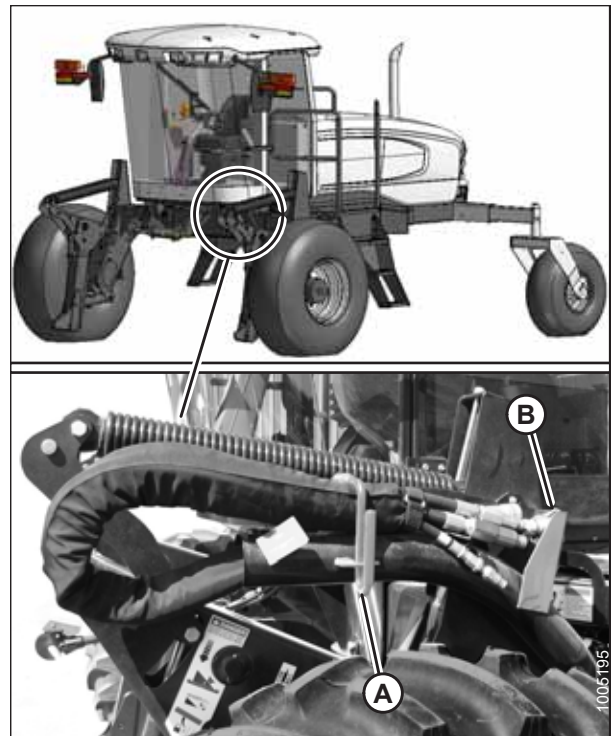

Figure 6.76: Hose Bundle

3. Move hose bundle (A) from the windrower and rest the bundle on the header.

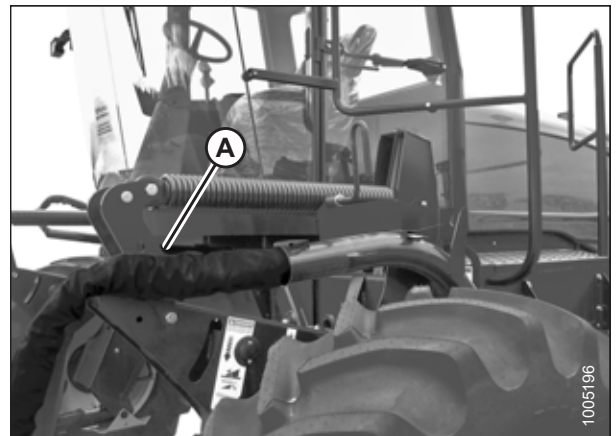

Figure 6.77: Hose Bundle

ATTACHING HYDRAULIC AND ELECTRICAL COMPONENTS

4. Position the hose support with lower bolt (A) in the forward hole as shown. Loosen both bolts, and adjust as required.

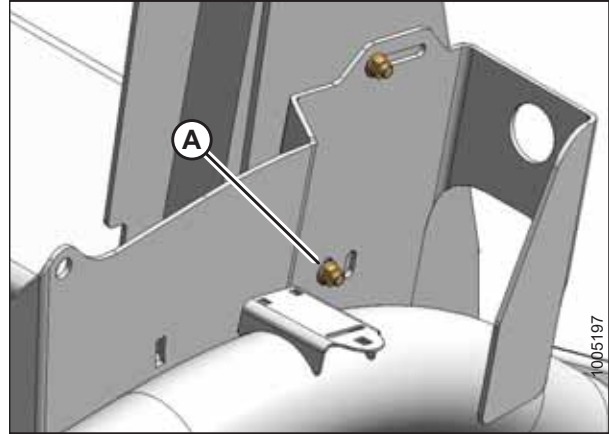

Figure 6.78: Hose Support

5. Move the windrower's left (cab-forward) platform (A) to the OPEN position. For instructions, refer to the windrower operator's manual.

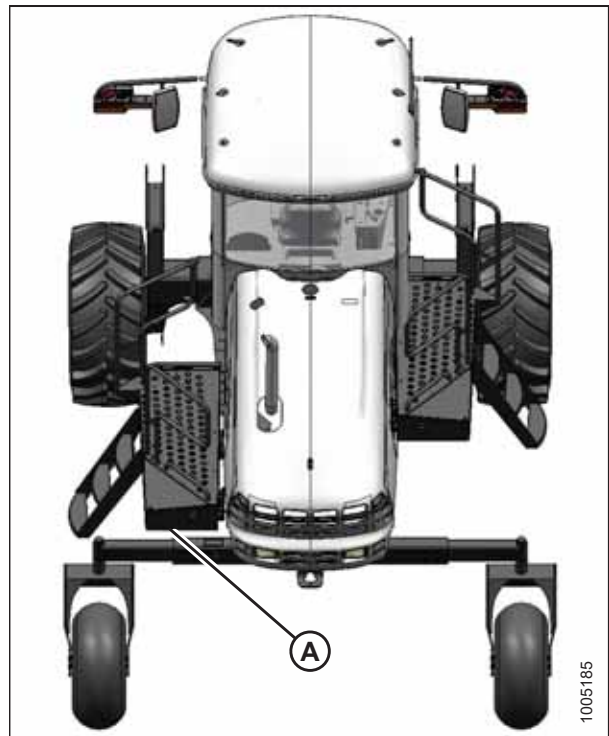

Figure 6.79: Windrower Left Platform in Open Position

ATTACHING HYDRAULIC AND ELECTRICAL COMPONENTS

6. Route windrower hose bundle (A) through hose support (B) on the header.
7. Route pressure hose (C) from the header through support (B) to the windrower.
8. Ensure that the open lines and ports are clean before making any hydraulic connections.

IMPORTANT:

Contaminated hydraulic connections increase the risk of hydraulic component failure.

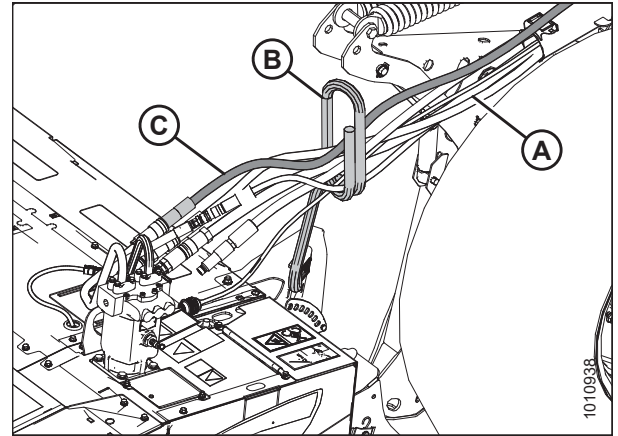

Figure 6.80: Hose Bundle

9. Connect pressure hose (A) routed from the header to port M2 on the disc drive valve (middle block).

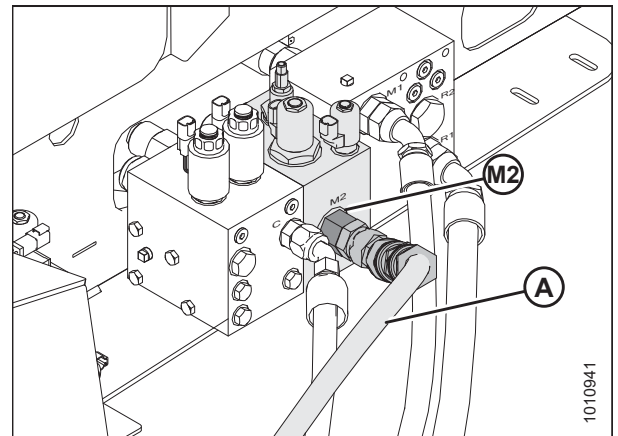

Figure 6.81: Hydraulic Connections

ATTACHING HYDRAULIC AND ELECTRICAL COMPONENTS

10. Remove caps and plugs on hoses from the windrower and lines on the header.
11. Connect pressure hose (B) from drive manifold port M1 to steel line (A) attached to motor port A.

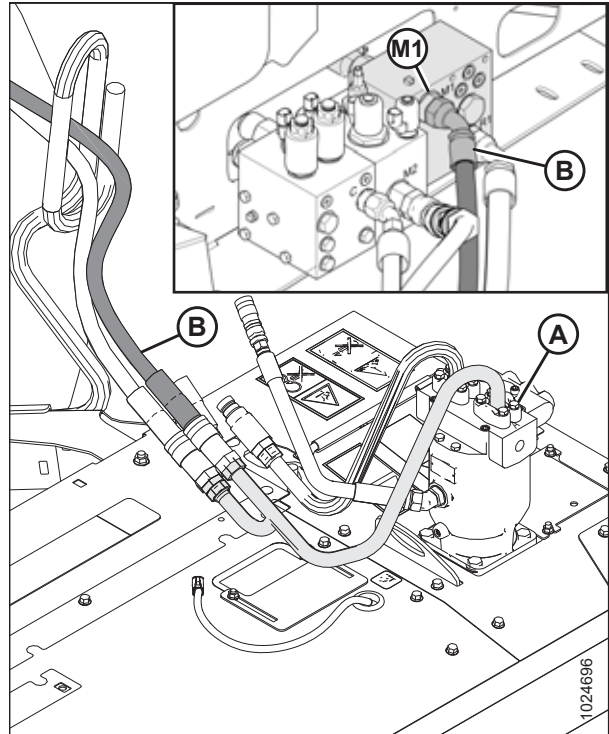

Figure 6.82: Hydraulic Connections

12. Connect return hose (A) from drive manifold port R1 to steel line (B) attached to motor port B.

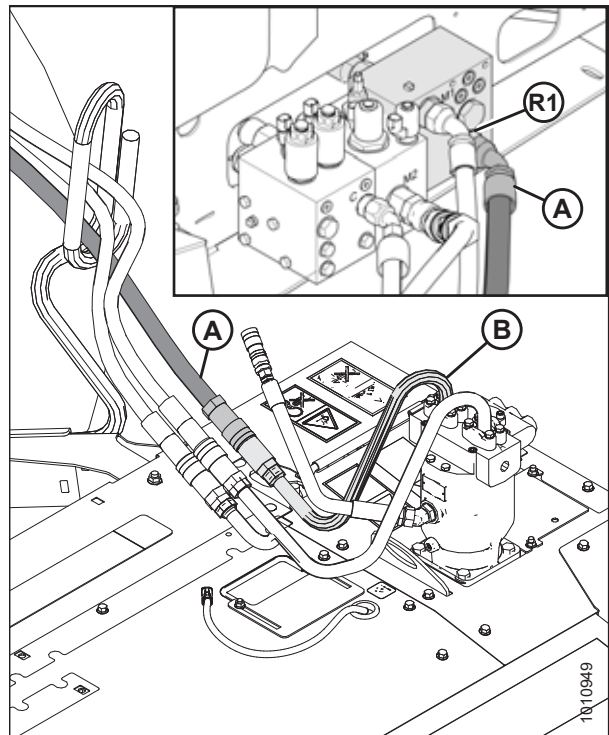

Figure 6.83: Hydraulic Connections

ATTACHING HYDRAULIC AND ELECTRICAL COMPONENTS

NOTE:

If the windrower is equipped with a reverser valve (A) for an auger header, route return hose (C) from port R1 on the reverser valve to steel line (B) attached to motor port B.

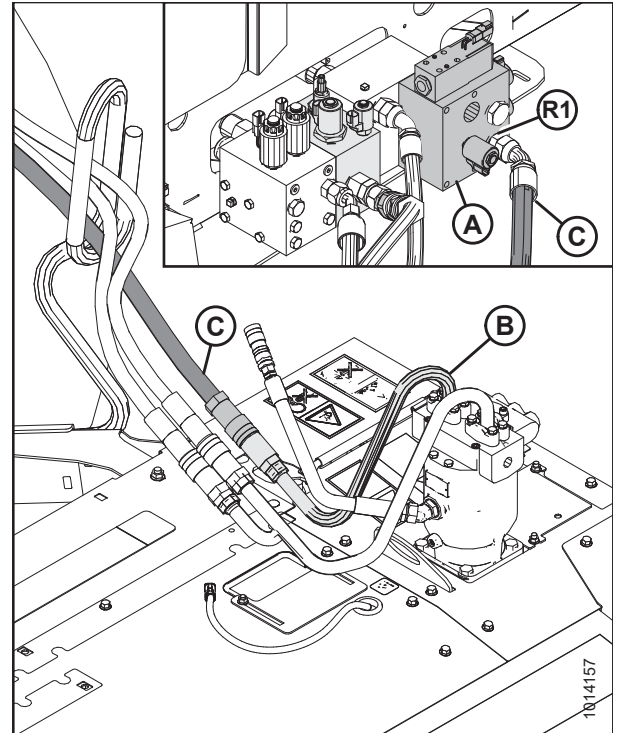

Figure 6.84: Windrower Hose Connections with Reverser

13. Connect case drain hose (A) from lift manifold port T3 to the fitting attached to motor port D.

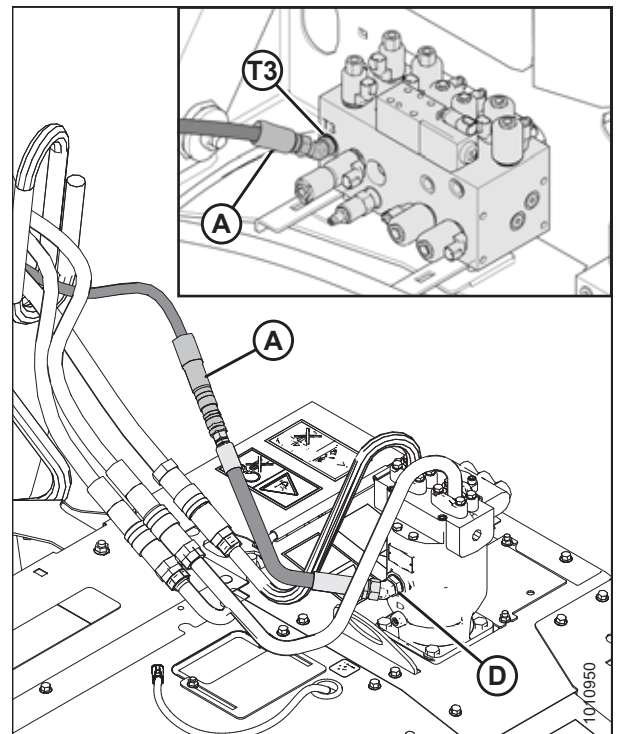

Figure 6.85: Hydraulic Connections

ATTACHING HYDRAULIC AND ELECTRICAL COMPONENTS

14. Connect electrical harness (A) from the windrower to the electrical connector on the header.

NOTE:

Hydraulic hoses removed from the illustration to improve clarity.

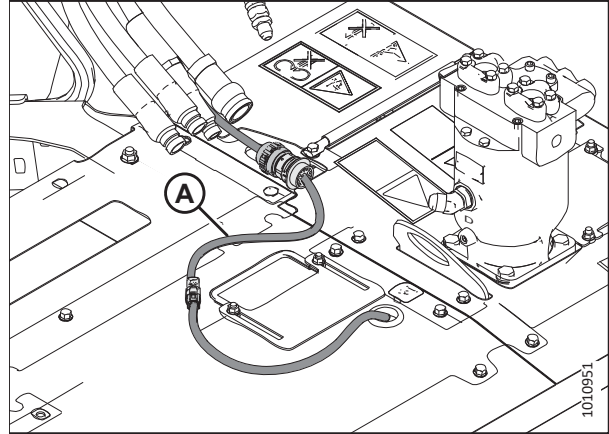

Figure 6.86: Electrical Connection

15. Lower and lock lever (A). Secure hose (B) with three cinch straps (C).

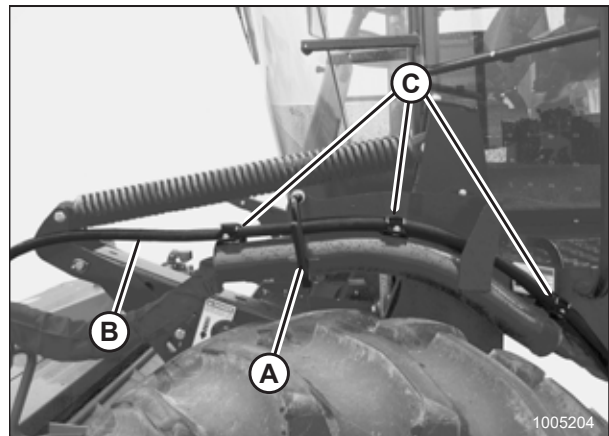

Figure 6.87: Hose Bundle

ATTACHING HYDRAULIC AND ELECTRICAL COMPONENTS

16. Move platform (A) to the CLOSED position. For instructions, refer to the windrower operator's manual.

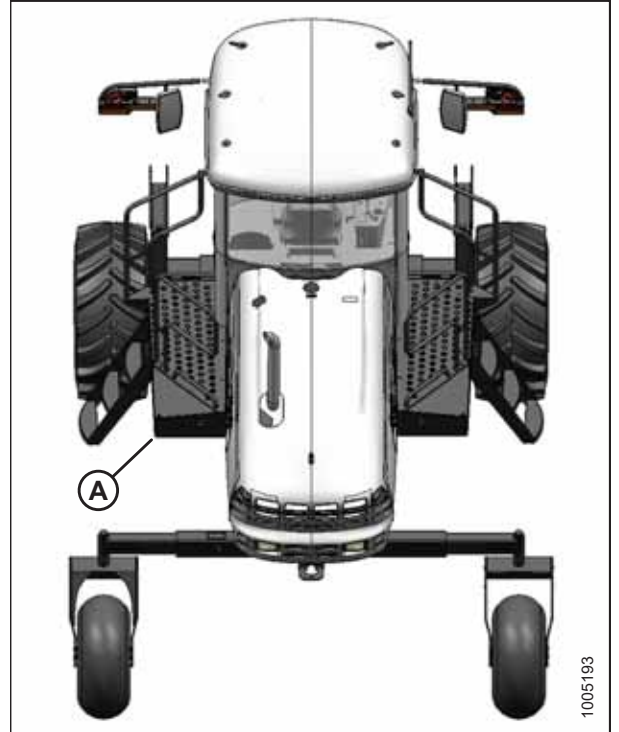

Figure 6.88: Top View of Windrower

6.6 Connecting Header Hydraulic and Electrical Systems – M205 Windrower

Connect the header hydraulic and electrical components to the windrower to operate the header.

Connect the R113 Rotary Disc Header to the M205 Windrower using the M205 Compatibility kit (MD #257188). For instructions, refer to the M205 Compatibility kit, or *Connecting R113 Rotary Disc Header Hydraulics and Electrical – M205 Windrower* in the header's operator manual.

Chapter 7: Unpacking Curtains

The curtain is installed at the front of the header. It minimizes the risk of thrown objects ejected at high speed from the cutterbar area.

WARNING

Ensure that the cutterbar is completely clear of foreign objects. These objects can be ejected with considerable force when the machine is started, which can result in serious injury to bystanders or equipment damage.

1. Remove two bolts (A) securing the cutterbar doors to the frame.

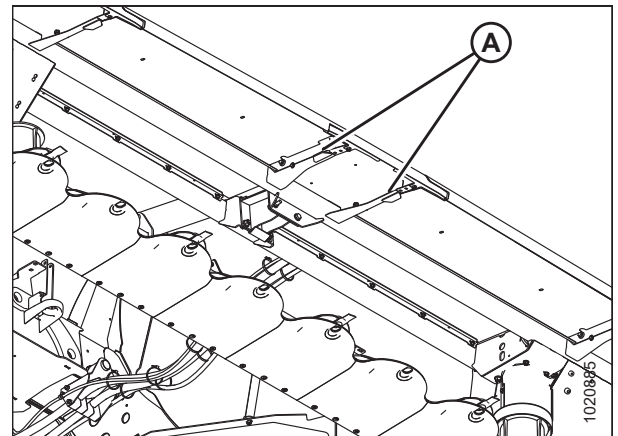

Figure 7.1: Cutterbar Doors – View Looking Up

2. Remove shipping wire (A) from around the curtains.

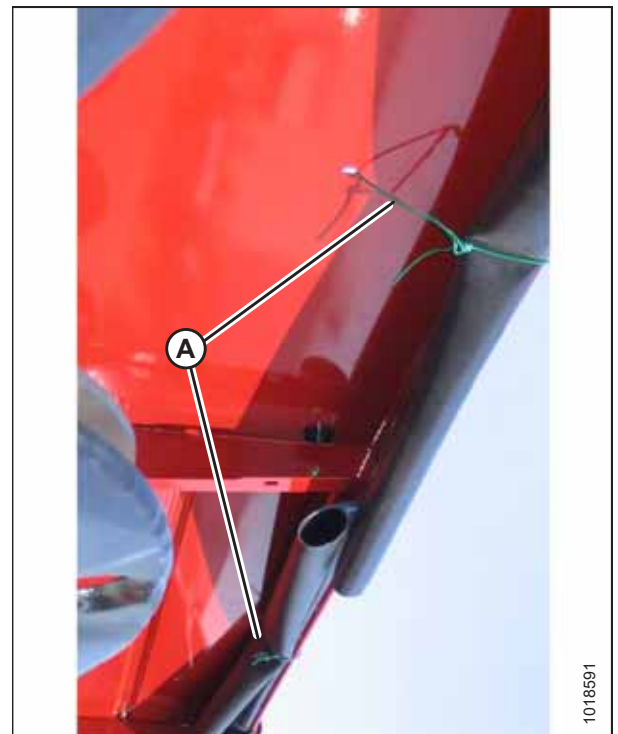

Figure 7.2: Curtain Secured for Shipping

UNPACKING CURTAINS

3. Open the cutterbar doors. For instructions, refer to [11.3.1 Opening Cutterbar Doors, page 130](#).
4. Check the cutterbar area for debris and foreign objects. Ensure that all material is removed.

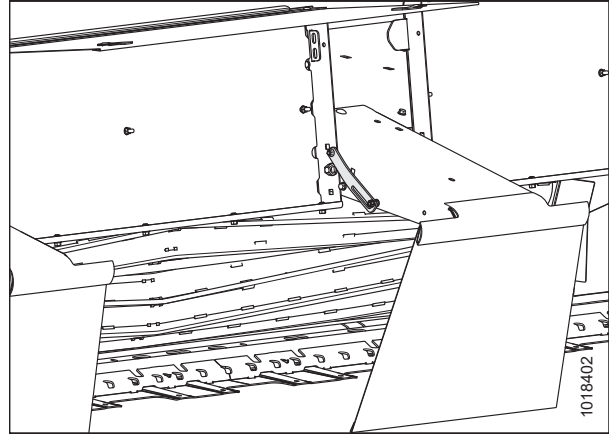

Figure 7.3: Cutterbar Doors Open

5. Close the cutterbar doors. For instructions, refer to [11.3.3 Closing Cutterbar Doors, page 132](#).
6. Ensure that the curtains hang properly and completely enclose the cutterbar area. Minor creases in the curtains will eventually straighten out.



Figure 7.4: Curtain – Unacceptable



Figure 7.5: Curtain – Acceptable

Chapter 8: Installing Options

Install options (if supplied with the shipment) according to the instructions supplied with each kit.

8.1 Installing Tall Crop Dividers

To install the Tall Crop Divider kit (B5800), follow these steps:

DANGER

To avoid bodily injury or death from unexpected startup of the machine, always stop the engine and remove the key from the ignition before leaving the operator's seat for any reason.

1. Lower the header fully.
2. Stop the engine, and remove the key from the ignition.
3. Unpack the Tall Crop Divider kit.
4. Open the cutterbar doors.
5. Remove four bolts (A) from divider (B). Retain the bolts for reinstallation.

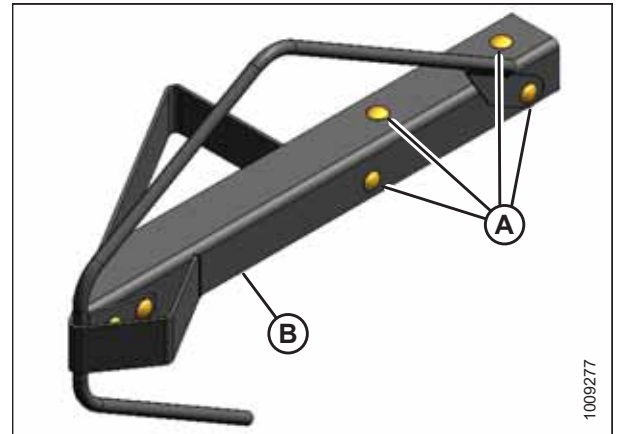

Figure 8.1: Tall Crop Divider – Left Shown, Right Opposite

6. Position left divider (B) on the left front corner, and install with four previously removed bolts (A) and nuts. Tighten the hardware.

NOTE:

The mounting holes in the rotary disc header should be vacant. If necessary, remove the fasteners.

7. Repeat Step 5, [page 109](#) to Step 6, [page 109](#) on the right side of the header.
8. Close the cutterbar doors.

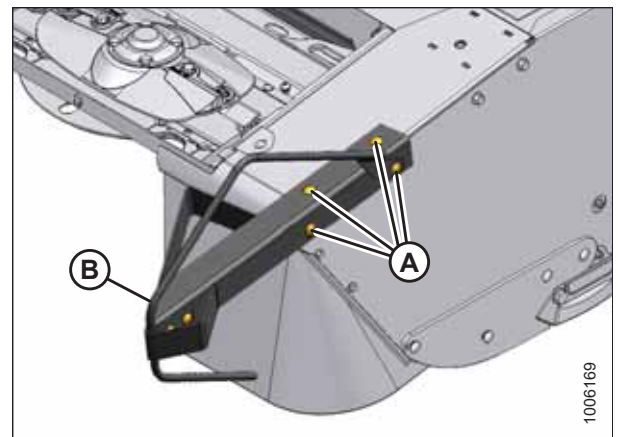

Figure 8.2: Tall Crop Divider – Left Shown, Right Opposite

Chapter 9: Lubricating Rotary Disc Header

The rotary disc header has been lubricated at the factory; however, you should lubricate the rotary disc header prior to delivery to offset the effects of weather during outside storage and transport.



DANGER

To prevent bodily injury or death from the unexpected startup of the machine, always stop the engine and remove the key from the ignition before leaving the operator's seat for any reason.

Refer to [9.1 Lubrication Locations, page 112](#) for a list of grease points on both the right and left sides of the header.

9.1 Lubrication Locations

The lubrication locations are identified according to the maintenance schedule for the header.

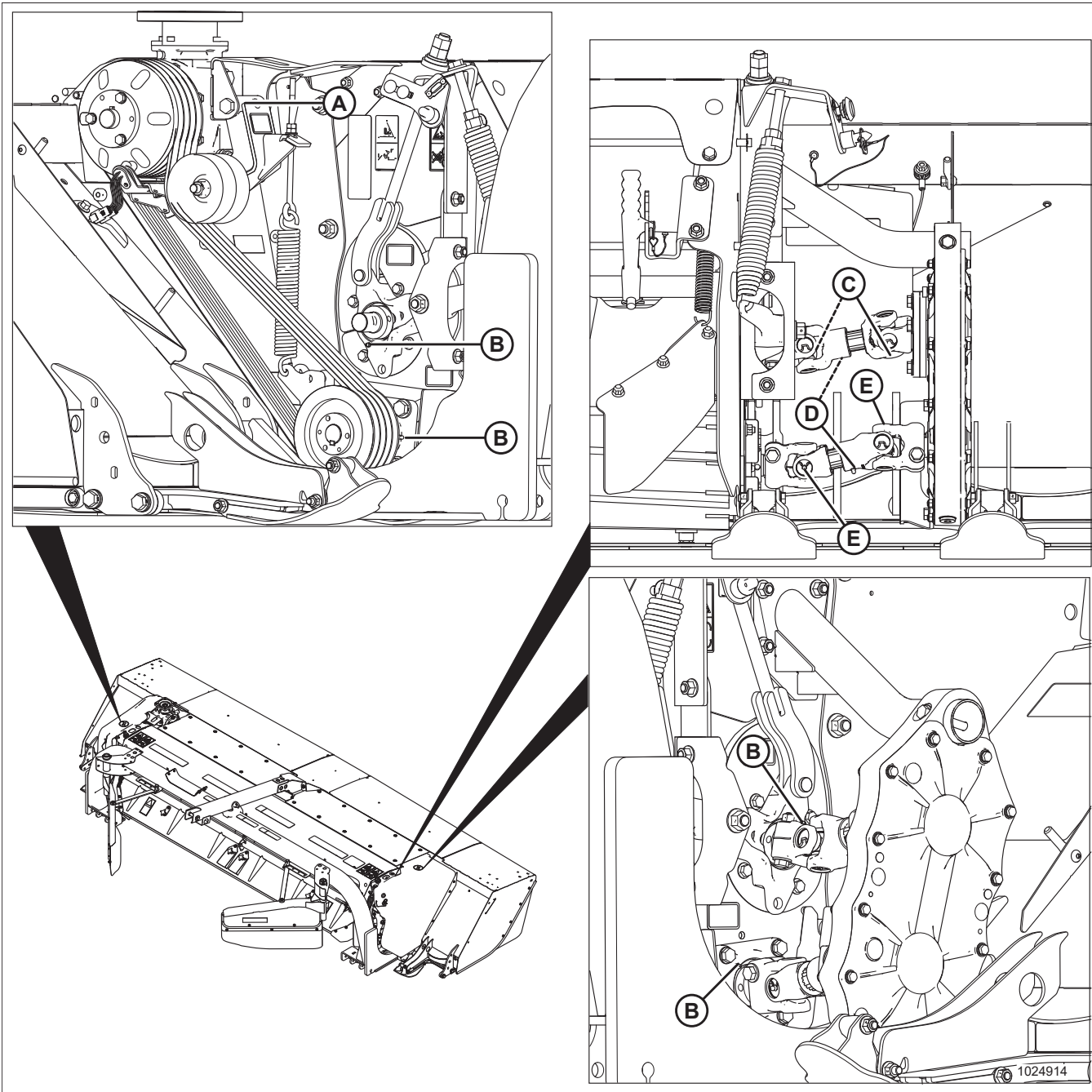

A - Idler/Tensioner Pivot
D - Slip Joints, Conditioner Drivelines²

B - Bearing, Roller Conditioner (4 Places)
E - U-Joint, Lower Driveline (2 Places)

C - U-Joint, Upper Driveline (2 Places)

2. Use high-temperature, extreme-pressure (EP2) performance grease with 10% max molybdenum disulphide (NLGI grade 2) lithium base.

Chapter 10: Performing Predelivery Checks

Perform final checks and adjustments as listed on the Predelivery Checklist (yellow sheet at the back of this instruction) to ensure that the machine is field-ready. Refer to the pages on the Predelivery Checklist for detailed instructions.

The Operator or the Dealer should retain the completed Predelivery Checklist.

10.1 Performing Predelivery Checks

Perform the final checks and adjustments as listed on the Predelivery Checklist (yellow sheet inside the back cover of this instruction) to ensure the machine is field-ready.

Refer to the following pages for detailed instructions as indicated on the . The completed Checklist should be retained either by the Operator or the Dealer.



DANGER

Follow these safety guidelines during predelivery checks to prevent bodily injury or death:

- Always shut off the engine and remove the key from the ignition before adjusting or inspecting the machine, or leaving the operator's seat for any reason.
- If the machine is raised, always place blocks under each end of the cutterbar, and close the lock-out valves. Never work on or beneath an unsupported machine.
- Block the machine wheels before detaching it from the tractor.
- Clear the area of bystanders.



WARNING

Follow these safety guidelines during predelivery checks to prevent bodily injury or death:

- Install all machine shields and covers before operating the machine.
- Wear close-fitting clothing and cover long hair. NEVER wear dangling items such as hoodies, scarves, or bracelets.
- Wait for shafts and other parts to stop moving before approaching them.
- Wear safety glasses and safety gloves when working near the cutterbar.
- Never exceed the maximum inflation pressure indicated on the tire label.

IMPORTANT:

To avoid machine damage, check that no shipping dunnage has fallen into cutterbar.

IMPORTANT:

Set the hydraulic flow rate to between 10–15 percent to provide optimal flow to the auxiliary lift cylinder control valve.

NOTE:

For recommended fluids and lubricants, refer to the chart on the inside back cover.

10.1.1 Checking and Adjusting Conditioner Drive Belt

1. Check that belt (A) is properly tensioned and positioned on the pulleys. Overall spring length (B) should be 365 mm (14 3/8 in.). To adjust the spring length, do the following:
 - a. Turn jam nut (C) counterclockwise to unlock the tension adjustment.
 - b. To increase the spring length (tension), turn adjuster nut (D) clockwise. To decrease the spring length (relax), turn adjuster nut (D) counterclockwise.
2. Check that jam nut (C) and adjuster nut (D) are tight.

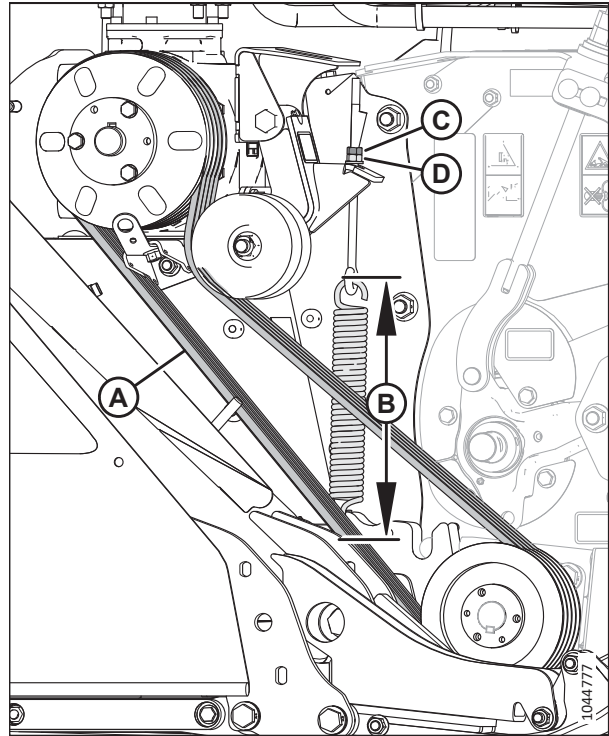

Figure 10.1: Conditioner Drive Belt

10.1.2 Checking Skid Shoes

All skid shoes (A) should be at the same position, either up (shown at right) or down. If adjustment is required, refer to the machine's operator's manual.

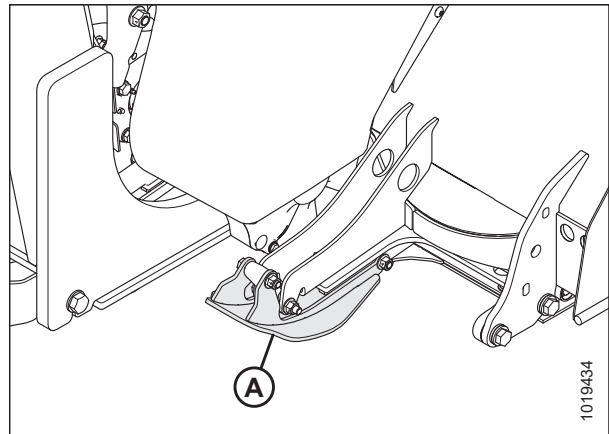

Figure 10.2: R113 SP Skid Shoe

10.1.3 Checking and Adjusting Forming Shield Deflector Position

The position of the side deflectors controls the width and placement of the windrow. Both side deflectors must be evenly set at the same position. If the side deflectors are not evenly set, follow the steps below to adjust them:

DANGER

To avoid bodily injury or death from unexpected startup of the machine, always stop the engine and remove the key from the ignition before leaving the operator's seat for any reason.

1. Loosen locking handle (A).
2. Slide adjuster bar (B) along adjuster plate (C) to the desired deflector position, and then engage bar (B) into a notch in the adjuster plate.
3. Tighten locking handle (A).
4. Repeat on the opposite side of the deflector.

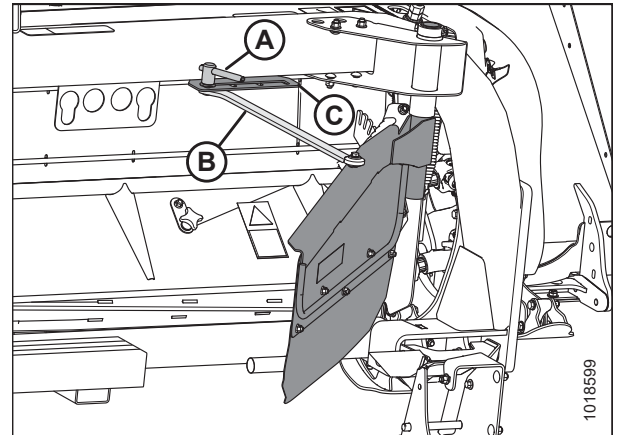

Figure 10.3: Right Forming Shield Side Deflector

10.1.4 Checking Header Float

1. Set the left and right float fine adjustments on the CDM to approximately 5.0. For instruction, refer to the windrower operator's manual.
2. Grasp the front corner of the rotary disc header and lift; the weight should feel approximately like 45 kg (100 lb.) at both ends. If adjustment is required, refer to .

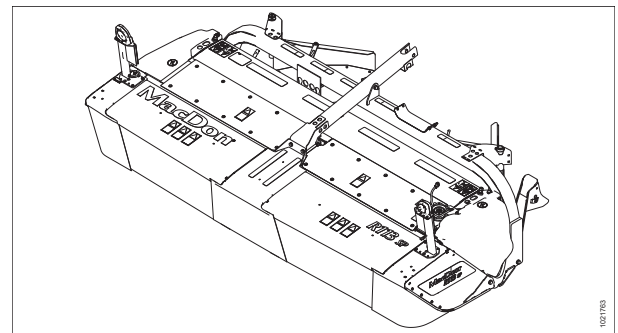

Figure 10.4: R113 SP

Checking Float – M1 Series Windrowers

You can check the header float setting by measuring the force required to lift the header.

DANGER

To prevent bodily injury or death from the unexpected startup of the machine, always stop the engine and remove the key from the ignition before leaving the operator's seat for any reason.

DANGER

Ensure that all bystanders have cleared the area.

PERFORMING PREDELIVERY CHECKS

1. Start the engine.
2. Use HEADER TILT switches (A) on the ground speed lever (GSL) to set the center-link to the mid-range position.
3. Using HEADER DOWN switch (B), lower the rotary disc header fully. The header lift cylinders will fully retract.
4. Ensure the header is level with the ground with zero tilt.

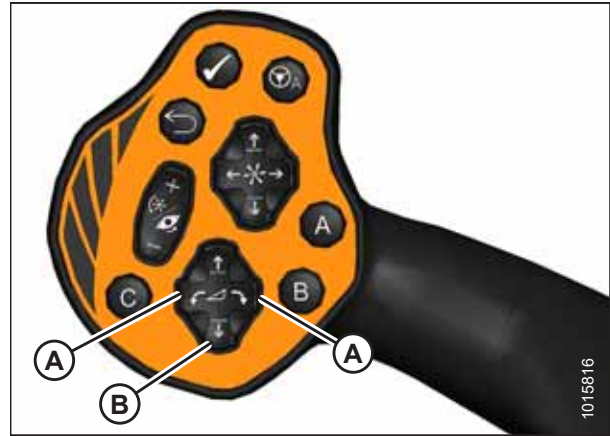

Figure 10.5: Ground Speed Lever (GSL)

5. Shut down the engine, and remove the key from the ignition.
6. Grasp one end of the header and lift it up. The lifting force should be 426–471 N (95–105 lbf) and should be the same at both ends.
7. Restart the engine, and adjust the float as needed. For instructions on adjusting the float with M1 Series Windrowers, refer to [Setting Float – M1 Series Windrowers, page 116](#). For instructions on adjusting the float with M2 Series Windrowers, refer to [Setting Float – M2 Series Windrowers, page 117](#).

NOTE:

Increasing the float makes the header feel lighter.

Setting Float – M1 Series Windrowers

The float can be set for windrowing with the cutterbar on the ground.

The optimum float setting lets the rotary disc header follow the contour of the terrain.

1. Set the center-link to the mid-range position (5.0 on the Harvest Performance Tracker [HPT]). For instructions, refer to the windrower operator's manual.
2. Lower the header until the cutterbar is on the ground.

NOTE:

To minimize scooping rocks when operating at the flattest header angle, lower the header skid shoes. For instructions, refer to the header operator's manual.

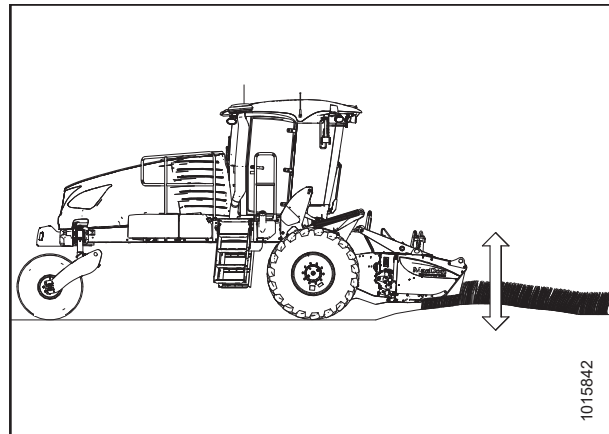

Figure 10.6: Header Float – Cutterbar on Ground

PERFORMING PREDELIVERY CHECKS

3. Press rotary scroll knob (A) on the HPT to display the QuickMenu page.
4. Rotate scroll knob (A) to highlight header float icon (B) and press the scroll knob to select.



Figure 10.7: HPT Run Screen

5. Turn scroll knob (A) to highlight left (B) or right float (C) and press knob (A) to activate the selection.
6. Rotate scroll knob (A) to adjust the float setting and press the knob.

NOTE:

Float adjustments of 1.0 (out of 10) change the header weight at the cutterbar by approximately 91 kg (200 lb.). Adjust the float in increments of 0.05 to optimize field performance.

7. Press soft key 3 (D) to remove or resume the header float.



Figure 10.8: HPT Float Settings

Setting Float – M2 Series Windrowers

The float can be set for windrowing with the cutterbar on the ground.

The optimum float setting lets the rotary disc header follow the contour of the terrain.

1. Set the center-link to the mid-range position (5.0 on the HarvestTouch™ Display). For instructions, refer to the windrower operator's manual.

PERFORMING PREDELIVERY CHECKS

- When cutting on the ground, lower the header until the cutterbar is on the ground.

NOTE:

To minimize scooping rocks when operating at the flattest header angle, lower the header skid shoes. For instructions, refer to the header operator's manual.

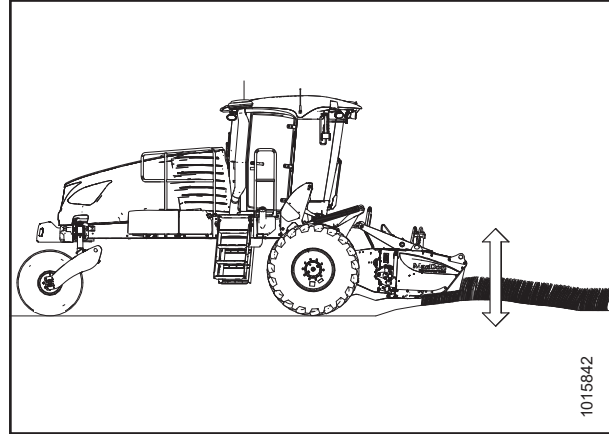

Figure 10.9: Header Float – Cutterbar on Ground

- Press FLOAT SETTINGS icon (A) on the HarvestTouch™ Display to show the float setting page.

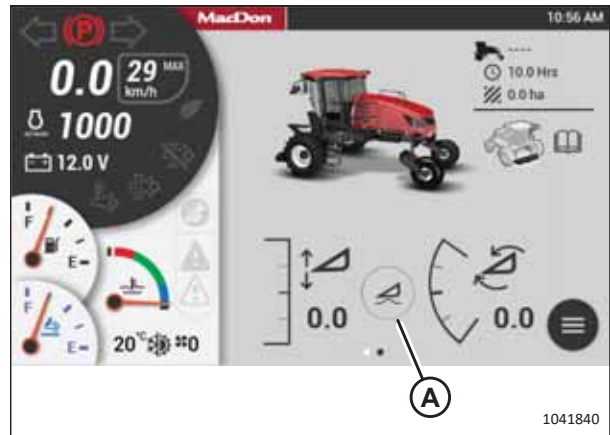

Figure 10.10: HarvestTouch™ Display

- Press arrows (A) to adjust left or right float settings.

NOTE:

Float adjustments of 1.0 (out of 10) change the header weight at the cutterbar by approximately 91 kg (200 lb.). Adjust the float in increments of 0.05 to optimize field performance.

- Press switch (B) to remove or resume the header float.

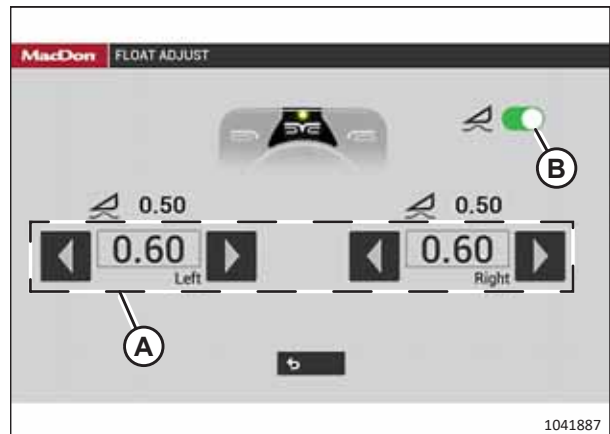

Figure 10.11: HarvestTouch™ Display

Checking Float – M Series Windrowers

The windrower is equipped with primary (coarse) and secondary (fine) float adjustment systems. The primary adjustment system allows the Operator to move the system’s drawbolts to change the tension on the springs in the lift linkages. The secondary adjustment system allows the Operator to use hydraulic cylinders to change the spring tension.

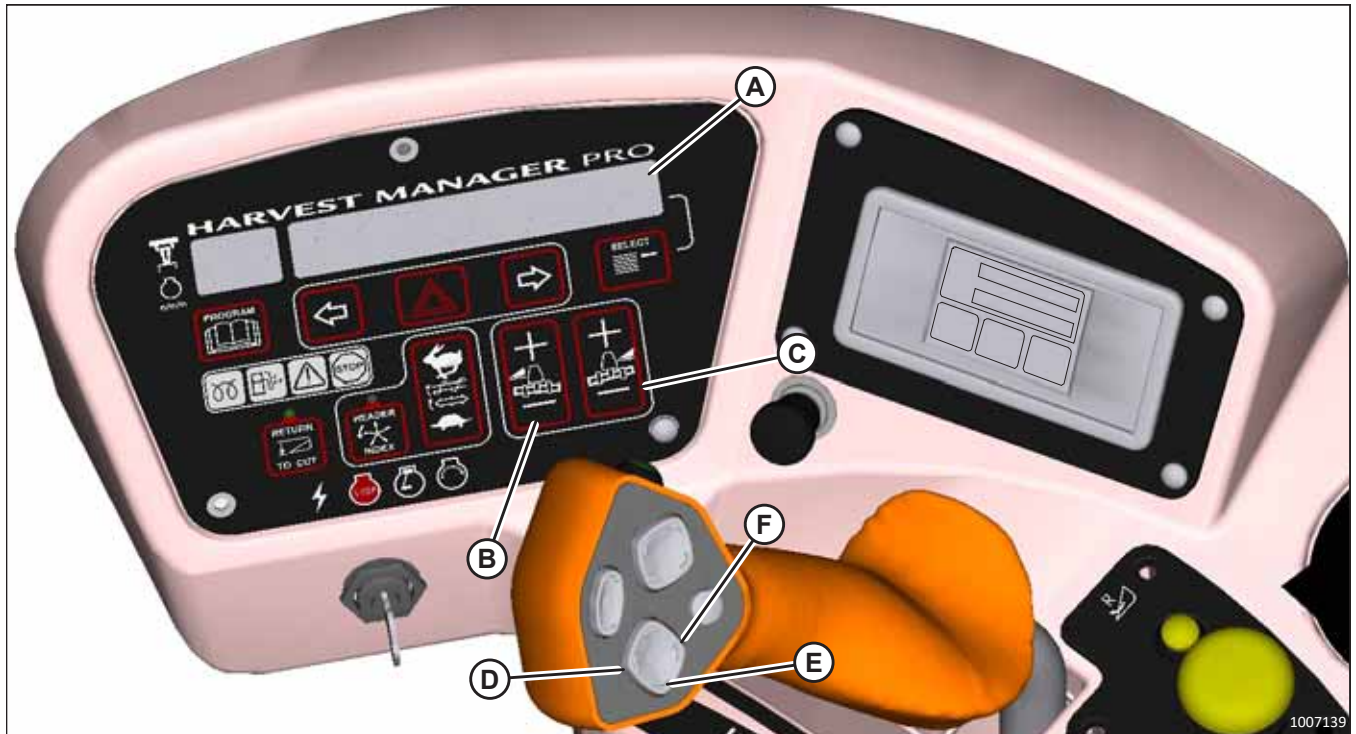

Figure 10.12: Cab Display Module (CDM) – M155E4 Shown, M155 Similar

- | | | |
|----------------------|---------------------------|----------------------------|
| A - CDM Display | B - Left Float Adjustment | C - Right Float Adjustment |
| D - Header Tilt Down | E - Header Lower | F - Header Tilt Up |

⚠ DANGER

To prevent bodily injury or death from the unexpected startup of the machine, always stop the engine and remove the key from the ignition before leaving the operator’s seat for any reason.

⚠ DANGER

Ensure that all bystanders have cleared the area.

1. Start the engine.
2. Lower the header fully.
3. Using HEADER TILT switches (D) and (F), set the center-link to the mid-range position (5.0 on cab display module [CDM] [A]).
4. Using HEADER DOWN switch (E), lower the header fully until the lift cylinders fully retract.

PERFORMING PREDELIVERY CHECKS

5. Set the left and right float fine adjustments on the CDM to approximately **5.0**:
 - a. Using FLOAT SELECTOR switch (B), push + to increase the float or – to decrease the float on the left side of the header. CDM display (A) will show the selected float setting for the left side (for example: **5.0 L FLOAT R XX.X**).
 - b. Repeat the previous step for the right side of the header float using switch (C). The display will show the float setting for both sides, (for example, **5.0 L FLOAT R 5.0**).
6. Shut down the engine, and remove the key from the ignition.
7. Grasp the end of the header and lift it up. The force to lift the end of the header should be 426–471 N (95–105 lbf) and should be approximately the same at both ends.

Adjusting Float Using Drawbolts – M Series Windrowers

Coarse float adjustment is done using the drawbolts located on both sides of the windrower.

DANGER

To prevent bodily injury or death from the unexpected startup of the machine, always stop the engine and remove the key from the ignition before leaving the operator's seat for any reason.

DANGER

Ensure that all bystanders have cleared the area.

1. Raise the header fully.
2. Shut down the engine, and remove the key from the ignition.
3. Turn drawbolt (A) clockwise to increase the float, or counterclockwise to decrease the float.
4. Recheck the header float. Refer to *Checking Float – M Series Windrowers, page 119* for instructions.

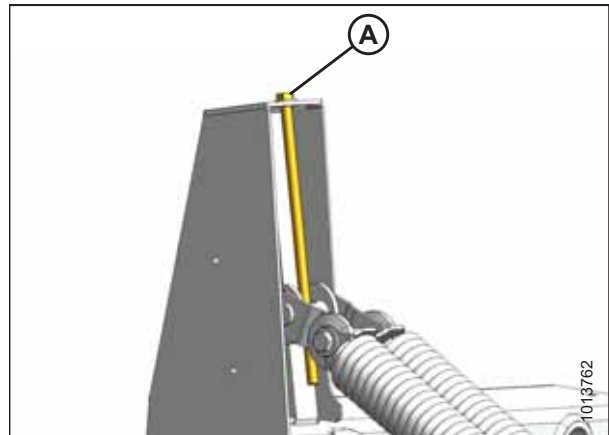

Figure 10.13: Header Float Adjustment

10.1.5 Checking and Adding Lubricant – Conditioner Roll Timing Gearbox

1. Lower the machine to the ground.
2. Adjust the cutting angle with the center-link so that the cutterbar is level.
3. Use a spirit (bubble) level and check that cutterbar is level in fore-aft direction. Adjust the cutting angle as required.
4. Clean around lubricant sight glass (A) and breather plug (B) on the conditioner roll timing gearbox.
5. Ensure that the lubricant level is at the top of the sight glass. If necessary, add lubricant through plug (B), then reinstall the plug.

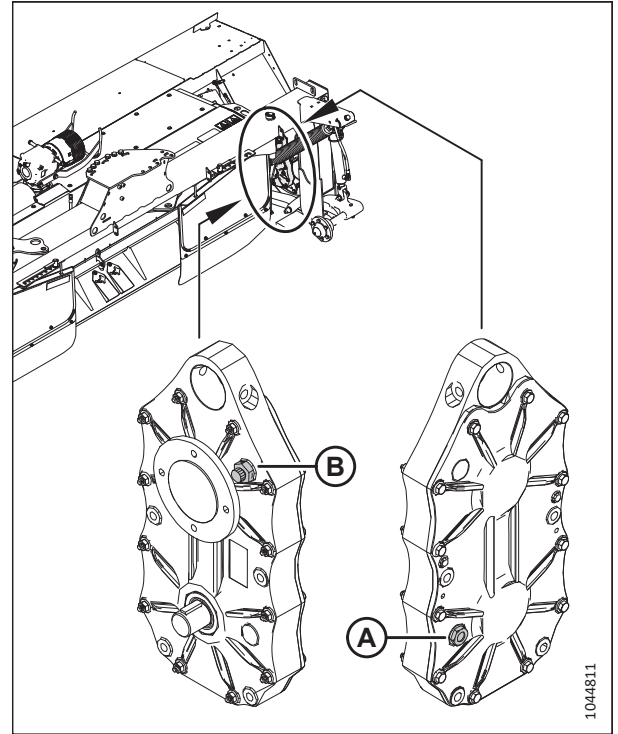

Figure 10.14: Roll Timing Gearbox

10.1.6 Checking and Adding Lubricant – Drive Gearbox

1. **New gearboxes or gearboxes after an oil change:** To ensure that the gearbox oil level is accurate, rotate cutterbar drum (A) a few turns. This will allow the oil to run into all gearbox cavities, such as the bottom bearings.

NOTE:

A new gearbox is a gearbox that has been filled with oil for the first time, but has not been operated yet.

2. Clean the area around dipstick (B).
3. Remove dipstick using a 22 mm socket.
4. Ensure the lubricant level is to the full line on the dipstick.
5. If necessary, add gear lubricant through dipstick hole (B).
6. Reinstall the dipstick and tighten it.

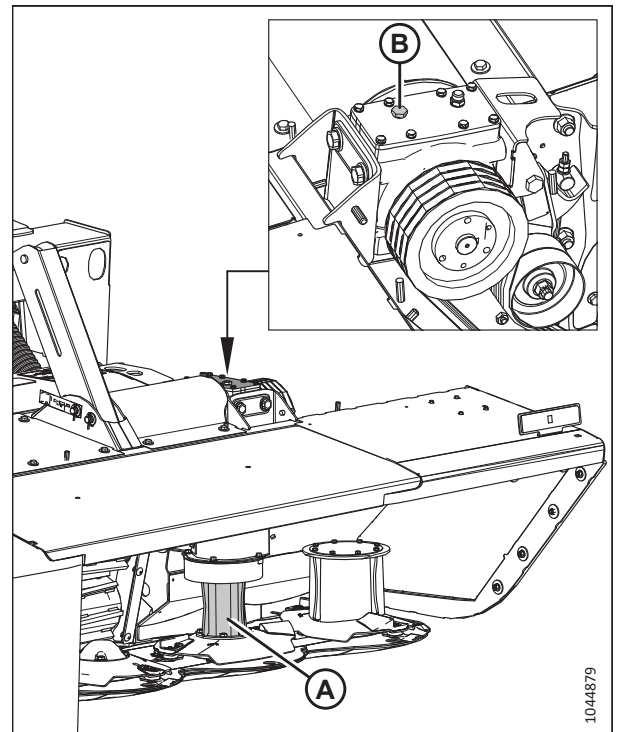

Figure 10.15: Left Side of

10.1.7 Checking and Adjusting Roll Gap

1. Lower the machine to the ground.
2. **Steel rolls:** Ensure that the roll gap is set to 6 mm (1/4 in.) (factory setting) as follows:

NOTE:

The length of thread (A) extending above the jam nut on the adjustment rods can be used as an approximation of roll gap, but does **NOT** provide consistent roll gap measurements.

- a. Loosen jam nut (B) on both sides of the conditioner.
- b. Turn lower nut (C) counterclockwise until the upper roll rests on the lower roll. Ensure the rolls intermesh.
- c. Turn lower nut (C) two and a half full turns clockwise to raise the upper roll and achieve a 6 mm (1/4 in.) roll gap.
- d. Hold nut (C) and tighten jam nut (B) on both sides of the conditioner.

IMPORTANT:

Make sure the roll gap adjustment nuts are adjusted equally on both sides to achieve a consistent gap across the rolls.

3. **Polyurethane rolls:** Insert a feeler gauge between the rolls from either front or rear of the machine and check that the roll gap is 3 mm (1/8 in.) (factory setting).

If adjustments are required, do the following:

- a. Loosen jam nut (B) on both sides of the conditioner.
- b. Turn lower nut (C) counterclockwise until the upper roll rests on the lower roll. Ensure the rolls intermesh.
- c. Turn lower nut (C) two and a half full turns clockwise to raise the upper roll and achieve a 3 mm (1/4 in.) roll gap.
- d. Hold nut (C) and tighten jam nut (B) on both sides of the conditioner.

IMPORTANT:

Make sure the roll gap adjustment nuts are adjusted equally on both sides to achieve a consistent gap across the rolls.

- e. Rotate the rolls manually and use a feeler gauge at the ends of the rolls to check that the actual gap is no less than 2 mm (1/16 in.) and no more than 4 mm (5/32 in.).

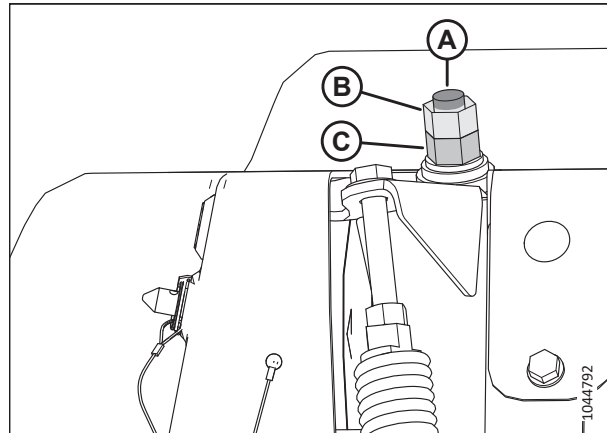

Figure 10.16: Roll Gap Adjustment

10.1.8 Checking Roll Timing

The roll timing is factory-set and should not require adjustment; however, if there is excessive noise coming from the conditioner rolls, the timing will need to be adjusted. Listen to the rollers. Excessive noise may come from dirt build up, or the rollers being out of time and would require adjustment. For instructions, refer to the header operator's manual.

10.1.9 Checking and Adjusting Roll Tension

1. Measure the amount of exposed thread on the roll tension adjuster bolt (A) at each end of the conditioner. Measurement (B) should be 12–15 mm (1/2–9/16 in.) for roll conditioners.
2. If the tension requires adjusting, do the following:
 - a. Loosen jam nut (C) on both sides of the conditioner.
 - b. Adjust dimension (B) as follows:
 - To increase the dimension, turn bolt (A) clockwise.
 - To decrease the dimension, turn bolt (A) counterclockwise.

IMPORTANT:

Turn each bolt equally.

- c. Tighten jam nuts (A) on each end of the conditioner.

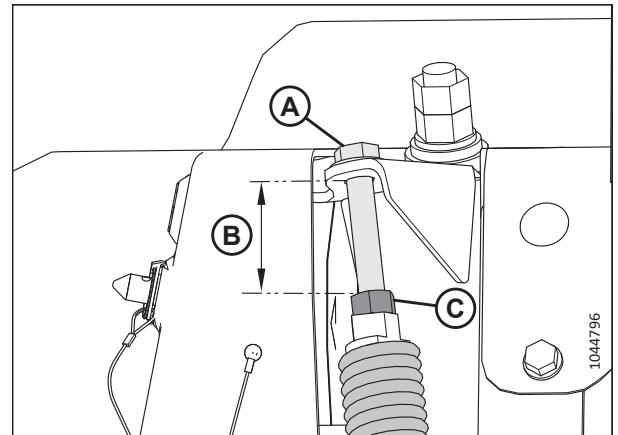

Figure 10.17: Roll Tension Adjuster

10.1.10 Adjusting Conditioner Baffle Position

The position of the adjustable conditioner baffle, along with the forming shields, determines the height and width of the windrow: raising the baffle produces a fluffier, narrower windrow; lowering the baffle produces a flatter, wider windrow.

1. Remove clip (A).
2. Move baffle adjustment handle (B) to the desired position on adjustment plate (C).
3. Install clip (A).

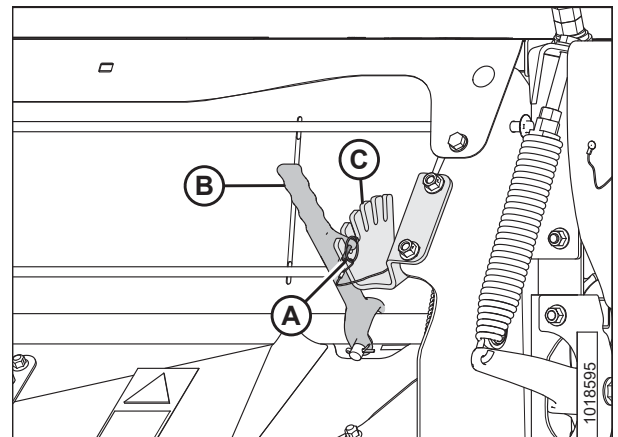

Figure 10.18: Conditioner Baffle Adjuster

10.1.11 Checking Lights

1. Check light mountings (A) for security and damage.
2. Check operation of hazard lights (B) during machine run-up.

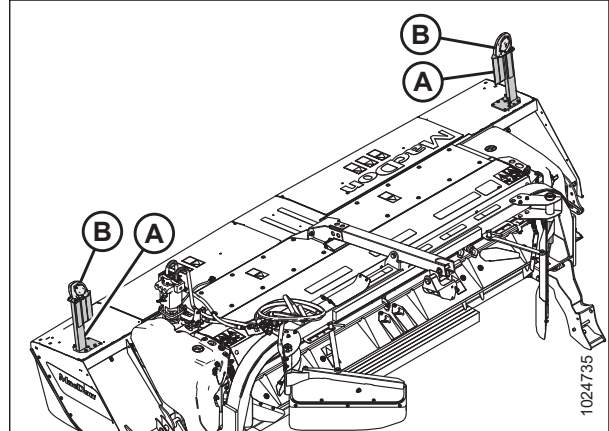

Figure 10.19: Lights

10.1.12 Checking Manuals

Confirm the following are stored in manual storage case (A):

- R1 Series Rotary Disc Header Operator's Manual
- R113 Rotary Disc Headers Parts Catalog
- R1 Series Rotary Disc Header Quick Card

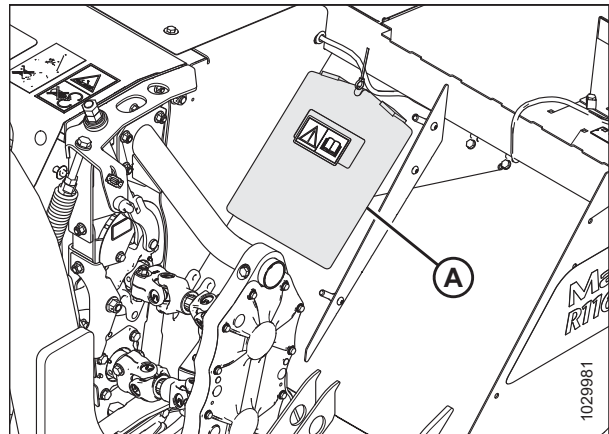

Figure 10.20: Manual Case

10.1.13 Checking Disc Timing Tool

Confirm that disc timing tool (A) is stored on the left of the machine.

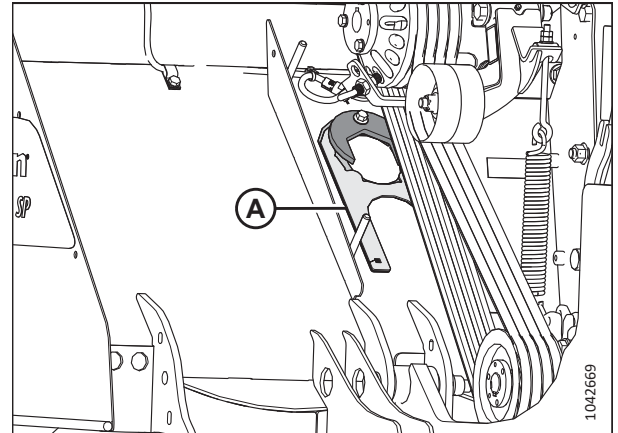

Figure 10.21: Disc Timing Tool

10.1.14 Running up Machine

WARNING

- Ensure that bystanders remain at least 100 m (330 ft.) from the header while it is operating. Stones and other objects can be ejected from the header with great force.
- Inspect the cutterbar area carefully for loose hardware. These objects can be ejected with great force when the header is engaged, resulting in serious injury or damage.
- Cutterbar curtains reduce the potential for thrown objects. Always keep these curtains down when operating the disc header. Replace the curtains if they become worn or damaged.

NOTE:

A higher engine rpm may be required to engage the machine. Do **NOT** exceed 1800 rpm.

1. Set the machine 152–305 mm (6–12 in.) above the ground and adjust the center-link to mid-position.
2. Run the machine slowly for 5 minutes, and watch and listen **FROM THE OPERATOR'S SEAT** for binding or interfering parts.
3. Run the machine at operating speed for 15 minutes. Listen for any unusual sounds or abnormal vibration.
4. Perform the run-up check as listed on the Predelivery Checklist (the yellow sheet inside the back cover of this instruction) to ensure that the machine is field-ready.
5. Retain the Predelivery Checklist and this instruction for future reference.

10.1.15 Checking and Adding Lubricant – Cutterbar

IMPORTANT:

Check the cutterbar lubricant level when the lubricant is warm. If the lubricant is cold, idle the machine for approximately 10 minutes prior to checking.

PERFORMING PREDELIVERY CHECKS

1. Lower the machine onto 25 cm (10 in.) blocks under both ends of the cutterbar.
2. Use spirit level (A) to ensure that the cutterbar is level in both directions. Adjust the cutterbar position accordingly.

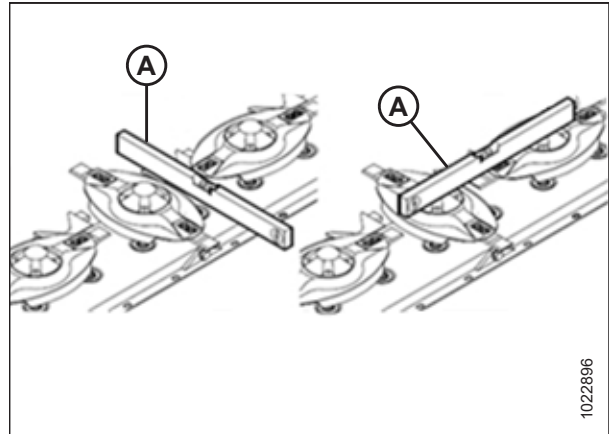

Figure 10.22: Spirit Level on Cutterbar

3. Clean the area around plug (A). Place a 5 liter (5.2 US qts) capacity container under the plug.
4. Remove plug (A) and O-ring (B) from the cutterbar. The oil level must be up to the inspection plug hole. If additional lubricant is required, do the following:
 - a. Reinstall the inspection plug.
 - b. Lower the header onto blocks, so that the left end is slightly higher than the right end.
 - c. Remove the inspection plug, and add some oil. Loosely install the inspection plug.

IMPORTANT:

Do **NOT** overfill the cutterbar. Overfilling can cause overheating, damage, and failure of the cutterbar components.

- d. Recheck the oil level (repeat Step 1, page 126 to Step 4, page 126).
5. Check O-ring (B) for breaks or cracks, and replace it if necessary.
 6. Install plug (A) and O-ring (B).

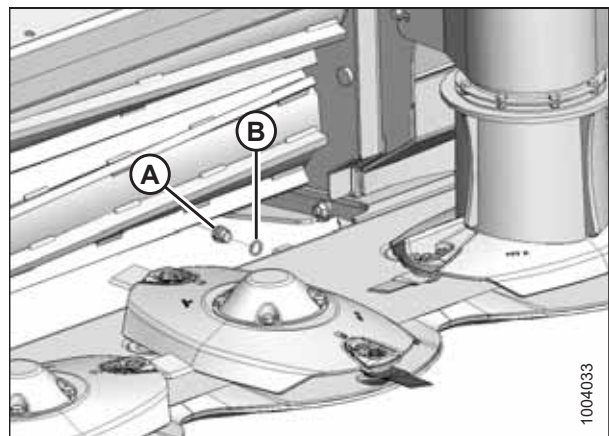

Figure 10.23: Cutterbar Oil Inspection Plug

Chapter 11: Reference

Additional information and commonly repeated procedures are included in the reference chapter.

11.1 Opening Driveshields

The driveshields offer protection from moving components. Open them only when you intend to service the machine.

DANGER

To prevent bodily injury or death from the unexpected start-up of the machine, always stop the engine and remove the key from the ignition before making adjustments to the machine.

WARNING

To reduce the risk of personal injury, do NOT operate the machine without the driveshields in place and secured.

NOTE:

The illustrations in this procedure show the left driveshield; the right driveshield is similar.

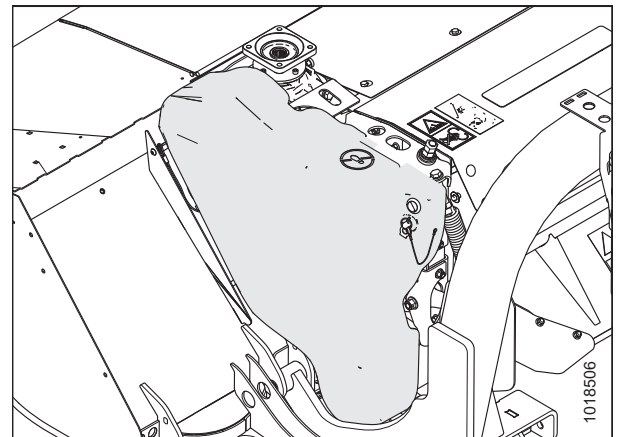

Figure 11.1: Left Driveshield

1. Shut down the engine, and remove the key from the ignition.
2. Remove lynch pin (A) and tool (B) from pin (C).

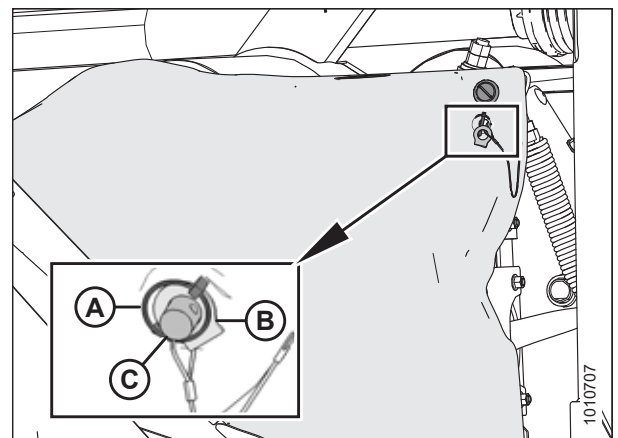

Figure 11.2: Left Driveshield

REFERENCE

3. Insert the flat end of tool (A) into latch (B) and turn it counterclockwise to unlock the driveshield.

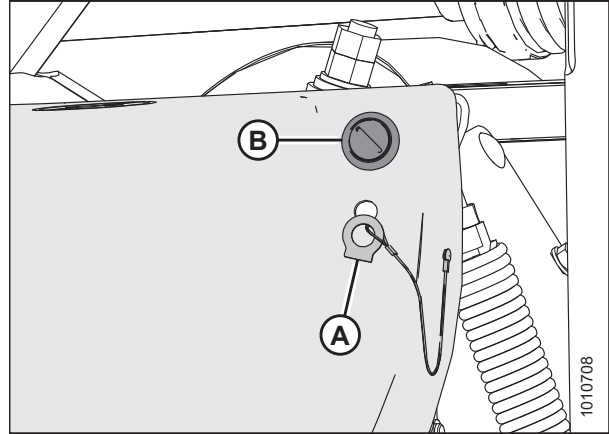

Figure 11.3: Driveshield Latch

4. Pull the top of driveshield (A) away from the machine to open it.

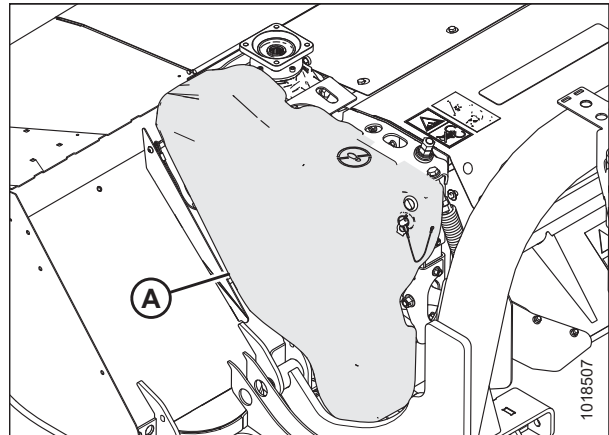

Figure 11.4: Left Driveshield

11.2 Closing Driveshields

Close the driveshields when your maintenance or repair tasks are complete.

WARNING

To reduce the risk of personal injury, do NOT operate the machine without the driveshields in place and secured.

NOTE:

The illustrations shown in this procedure apply to the left driveshield; the right driveshield is similar.

1. Position the driveshield onto the pins, if necessary.
2. Push driveshield (A) to engage latch (B).
3. Ensure that the driveshield is properly secured.

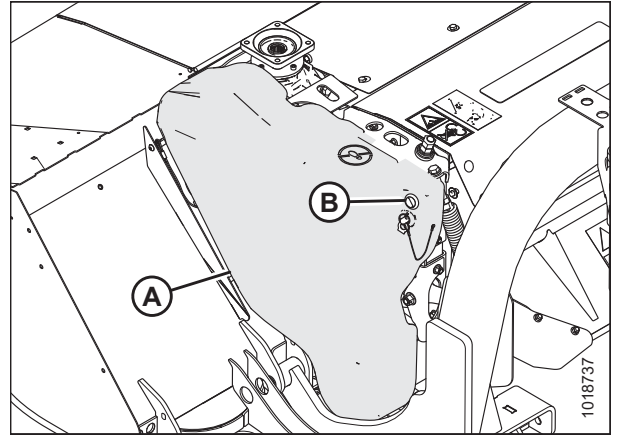

Figure 11.5: Left Driveshield

4. Replace tool (B) and lynch pin (A) onto pin (C).

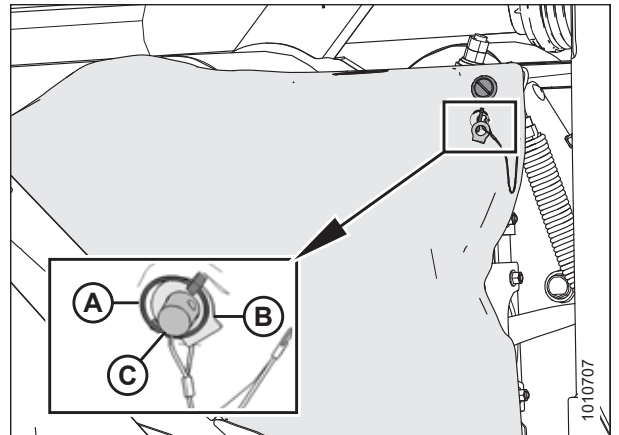

Figure 11.6: Left Driveshield

11.3 Cutterbar Doors

Two doors with rubber curtains provide access to the cutterbar area.

WARNING

To reduce the risk of personal injury and machine damage, do NOT operate the machine without all the cutterbar doors down or without curtains installed and in good condition. Objects in the path of the blades can eject with considerable force when the machine is started.

Rotary disc headers sold outside of North America have latches on cutterbar doors (A).

Curtains (B) and (C) are attached to each front corner and at the center respectively. Always lower the curtains when operating the rotary disc header.

IMPORTANT:

Replace the curtains if they become worn or damaged.

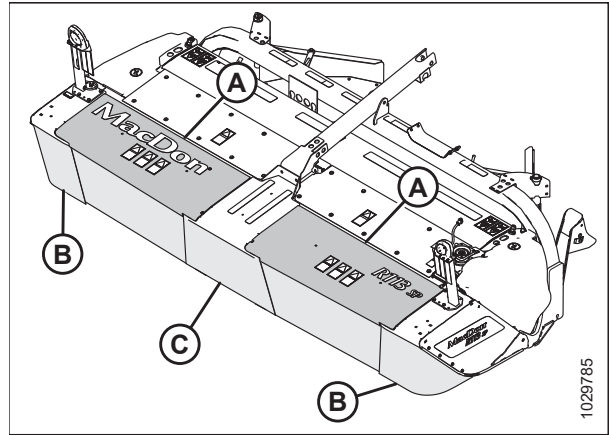

Figure 11.7: Cutterbar Doors and Curtains

11.3.1 Opening Cutterbar Doors

You will need to open the cutterbar doors to access the cutterbar.

If the machine was sold outside of North America, it will have export-style latches. For instructions, refer to [11.3.2 Opening Cutterbar Doors – Export, page 131](#).

DANGER

To prevent bodily injury or death from the unexpected startup of the machine, always stop the engine and remove the key from the ignition before leaving the operator's seat.

1. Shut down the engine, and remove the key from the ignition.
2. Lift up doors (A) at the front of the machine.

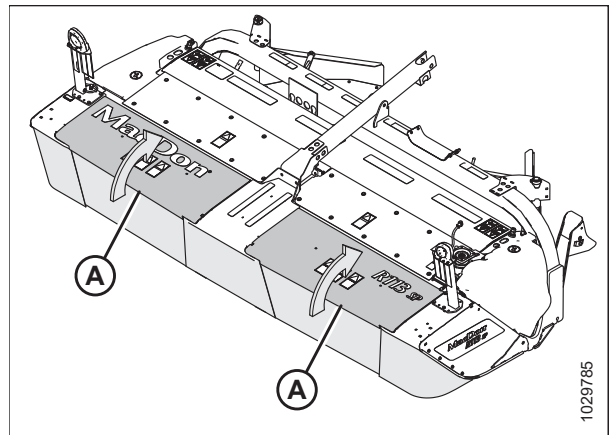

Figure 11.8: Cutterbar Doors and Curtains

11.3.2 Opening Cutterbar Doors – Export

Machines sold outside North America have a tool-operated latch on the cutterbar doors.

⚠ DANGER

To prevent bodily injury or death from the unexpected startup of the machine, always stop the engine and remove the key from the ignition before leaving the operator’s seat.

1. Shut down the engine, and remove the key from the ignition.
2. Locate latch access holes (A) for each door.

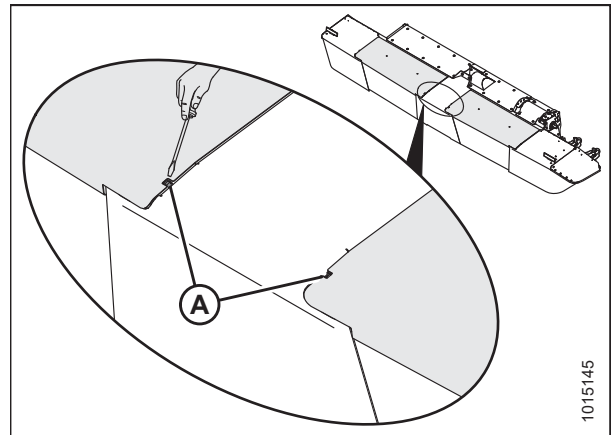

Figure 11.9: Cutterbar Door Latch Access Hole – Export Only

3. Use a rod or screwdriver to press down on latch (A) to release the cutterbar door.

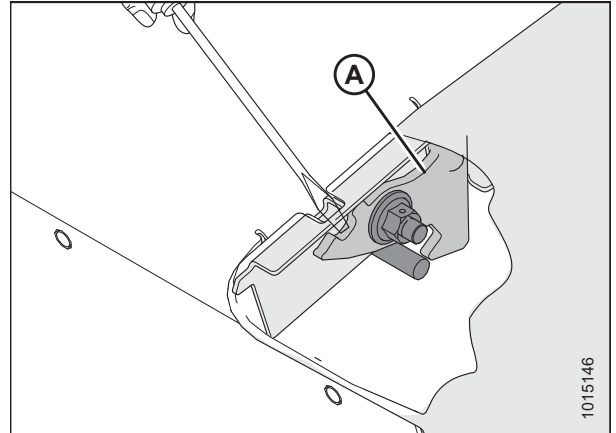

Figure 11.10: Cutterbar Door Latch – Cutaway View

REFERENCE

4. Lift up on doors (A) while pressing down on the latch.

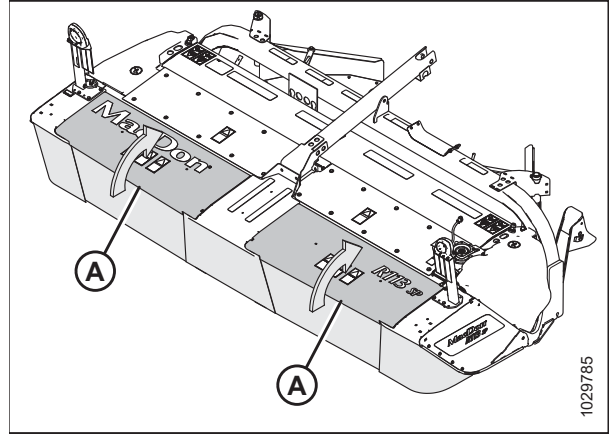

Figure 11.11: Cutterbar Doors and Curtains

11.3.3 Closing Cutterbar Doors

Do **NOT** operate the machine without closing the cutterbar doors.

CAUTION

Keep your hands and fingers away from the corners of the doors when you are closing them.

1. Pull down on door (A) from the top to close it.
2. Ensure that the curtains hang properly and completely enclose the cutterbar area.

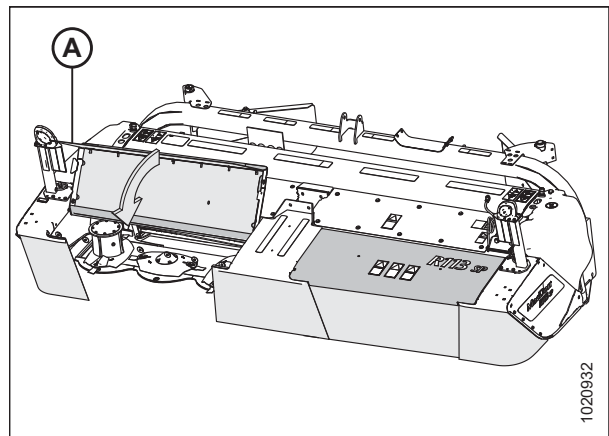

Figure 11.12: Cutterbar Doors and Curtains

11.4 Torque Specifications

The following tables provide torque values for various bolts, cap screws, and hydraulic fittings. Refer to these values only when no other torque value has been specified in a given procedure.

- Tighten all bolts to the torque values specified in the charts below, unless you are directed otherwise in this manual.
- Replace removed hardware with hardware of the same strength and grade.
- Refer to the torque value tables as a guide when periodically checking the tightness of bolts.
- Understand the torque categories for bolts and cap screws by reading the markings on their heads.

Jam nuts

Jam nuts require less torque than nuts used for other purposes. When applying torque to finished jam nuts, multiply the torque applied to regular nuts by 0.65 to obtain the modified torque value.

Self-tapping screws

Refer to the standard torque values when installing the self-tapping screws. Do **NOT** install the self-tapping screws on structural or otherwise critical joints.

11.4.1 Metric Bolt Specifications

Specifications are provided for the appropriate final torque values to secure various sizes of metric bolts.

NOTE:

The torque values provided in the following metric bolt torque tables apply to hardware installed dry; that is, hardware with no grease, oil, or threadlocker on the threads or heads. Do **NOT** add grease, oil, or threadlocker to bolts or cap screws unless you are directed to do so in this manual.

Table 11.1 Metric Class 8.8 Bolts and Class 9 Free Spinning Nut

Nominal Size (A)	Torque (Nm)		Torque (lbf-ft) (*lbf-in)	
	Min.	Max.	Min.	Max.
3-0.5	1.4	1.6	*13	*14
3.5-0.6	2.2	2.5	*20	*22
4-0.7	3.3	3.7	*29	*32
5-0.8	6.7	7.4	*59	*66
6-1.0	11.4	12.6	*101	*112
8-1.25	28	30	20	23
10-1.5	55	60	40	45
12-1.75	95	105	70	78
14-2.0	152	168	113	124
16-2.0	236	261	175	193
20-2.5	460	509	341	377
24-3.0	796	879	589	651

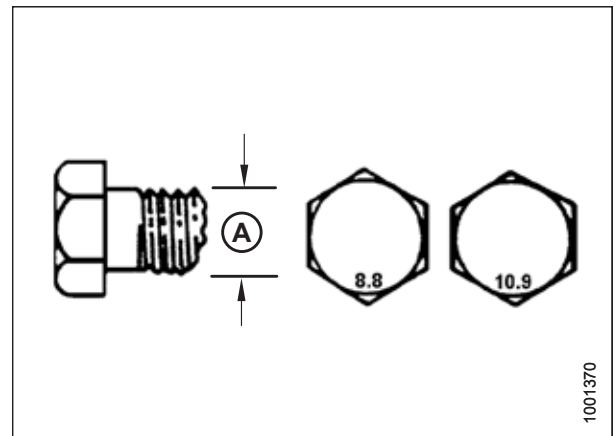

Figure 11.13: Bolt Grades

REFERENCE

Table 11.2 Metric Class 8.8 Bolts and Class 9 Distorted Thread Nut

Nominal Size (A)	Torque (Nm)		Torque (lbf-ft) (*lbf-in)	
	Min.	Max.	Min.	Max.
3-0.5	1	1.1	*9	*10
3.5-0.6	1.5	1.7	*14	*15
4-0.7	2.3	2.5	*20	*22
5-0.8	4.5	5	*40	*45
6-1.0	7.7	8.6	*69	*76
8-1.25	18.8	20.8	*167	*185
10-1.5	37	41	28	30
12-1.75	65	72	48	53
14-2.0	104	115	77	85
16-2.0	161	178	119	132
20-2.5	314	347	233	257
24-3.0	543	600	402	444

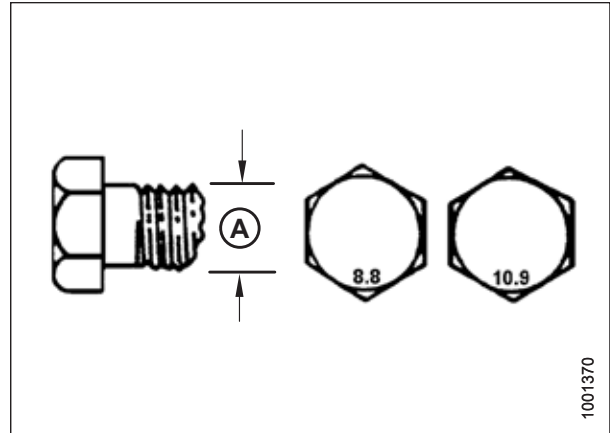

Figure 11.14: Bolt Grades

Table 11.3 Metric Class 10.9 Bolts and Class 10 Free Spinning Nut

Nominal Size (A)	Torque (Nm)		Torque (lbf-ft) (*lbf-in)	
	Min.	Max.	Min.	Max.
3-0.5	1.8	2	*18	*19
3.5-0.6	2.8	3.1	*27	*30
4-0.7	4.2	4.6	*41	*45
5-0.8	8.4	9.3	*82	*91
6-1.0	14.3	15.8	*140	*154
8-1.25	38	42	28	31
10-1.5	75	83	56	62
12-1.75	132	145	97	108
14-2.0	210	232	156	172
16-2.0	326	360	242	267
20-2.5	637	704	472	521
24-3.0	1101	1217	815	901

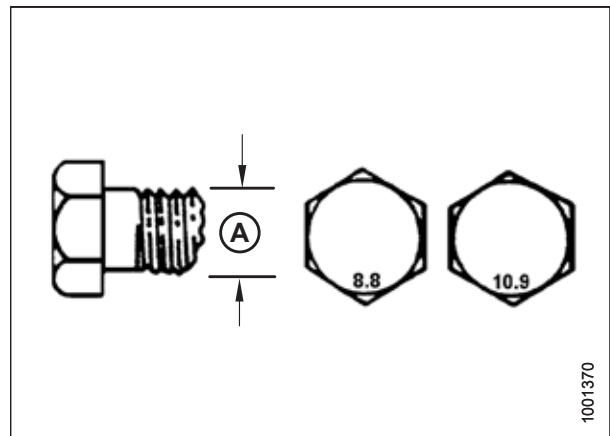

Figure 11.15: Bolt Grades

REFERENCE

Table 11.4 Metric Class 10.9 Bolts and Class 10 Distorted Thread Nut

Nominal Size (A)	Torque (Nm)		Torque (lbf-ft) (*lbf-in)	
	Min.	Max.	Min.	Max.
3-0.5	1.3	1.5	*12	*13
3.5-0.6	2.1	2.3	*19	*21
4-0.7	3.1	3.4	*28	*31
5-0.8	6.3	7	*56	*62
6-1.0	10.7	11.8	*95	*105
8-1.25	26	29	19	21
10-1.5	51	57	38	42
12-1.75	90	99	66	73
14-2.0	143	158	106	117
16-2.0	222	246	165	182
20-2.5	434	480	322	356
24-3.0	750	829	556	614

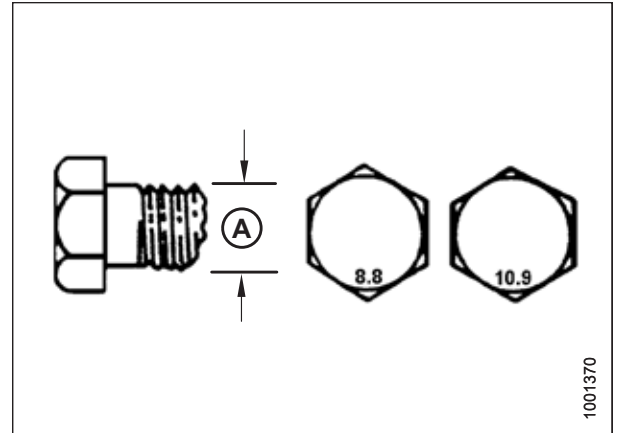

Figure 11.16: Bolt Grades

11.4.2 Metric Bolt Specifications – Cast Aluminum

Specifications are provided for the appropriate final torque values for various sizes of metric bolts in cast aluminum.

NOTE:

The torque values provided in the following metric bolt torque tables apply to hardware installed dry; that is, hardware with no grease, oil, or threadlocker on the threads or heads. Do **NOT** add grease, oil, or threadlocker to bolts or cap screws unless you are directed to do so in this manual.

Table 11.5 Metric Bolt Bolting into Cast Aluminum

Nominal Size (A)	Bolt Torque			
	8.8 (Cast Aluminum)		10.9 (Cast Aluminum)	
	Nm	lbf-ft	Nm	lbf-ft
M3	–	–	–	1
M4	–	–	4	2.6
M5	–	–	8	5.5
M6	9	6	12	9
M8	20	14	28	20
M10	40	28	55	40
M12	70	52	100	73
M14	–	–	–	–
M16	–	–	–	–

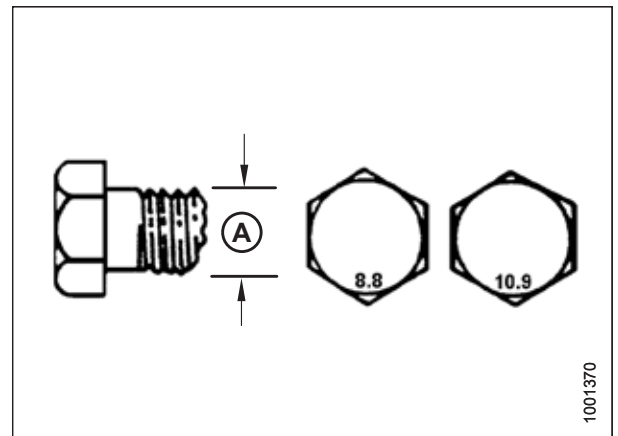

Figure 11.17: Bolt Grades

11.4.3 O-Ring Boss Hydraulic Fittings – Adjustable

The standard torque values are provided for adjustable hydraulic fittings. If a procedure specifies a different torque value for the same type and size of fitting found in this topic, refer to the value specified in the procedure instead.

1. Inspect O-ring (A) and seat (B) for dirt or defects.
2. Back off lock nut (C) as far as possible. Ensure that washer (D) is loose and that it is pushed toward lock nut (C) as far as possible.
3. Ensure that O-ring (A) is **NOT** on the threads. Adjust O-ring (A) if necessary.
4. Apply hydraulic system oil to O-ring (A).

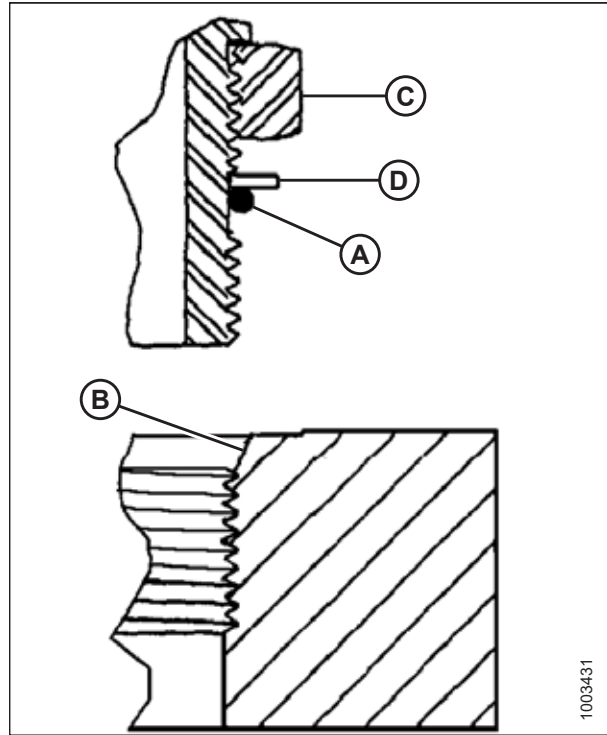

Figure 11.18: Hydraulic Fitting

5. Install fitting (B) into the port until backup washer (D) and O-ring (A) contact part face (E).
6. Position the angle fittings by unscrewing no more than one turn.
7. Turn lock nut (C) down to washer (D) and tighten it to the torque value indicated in the table. Use two wrenches, one on fitting (B) and the other on lock nut (C).
8. Verify the final condition of the fitting.

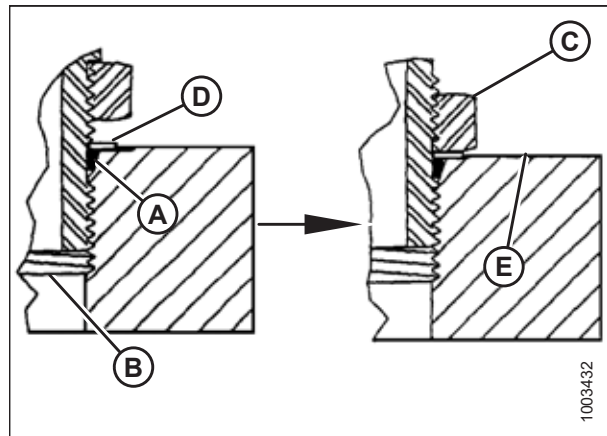

Figure 11.19: Hydraulic Fitting

REFERENCE

Table 11.6 O-Ring Boss (ORB) Hydraulic Fittings – Adjustable and Non-Adjustable

SAE Dash Size	Thread Size (in.)	Torque Value ³	
		Nm	lbf-ft (*lbf-in)
-2	5/16–24	10–11	*89–97
-3	3/8–24	18–20	*159–177
-4	7/16–20	29–32	21–24
-5	1/2–20	32–35	24–26
-6	9/16–18	40–44	30–32
-8	3/4–16	70–77	52–57
-10	7/8–14	115–127	85–94
-12	1 1/16–12	183–201	135–148
-14	1 3/16–12	237–261	175–193
-16	1 5/16–12	271–298	200–220
-20	1 5/8–12	339–373	250–275
-24	1 7/8–12	414–455	305–336
-32	2 1/2–12	509–560	375–413

11.4.4 O-Ring Boss Hydraulic Fittings – Non-Adjustable

The standard torque values for non-adjustable hydraulic fittings are provided. If a procedure specifies a different torque value for the same type and size of fitting found in this topic, use the value specified in the procedure instead.

1. Inspect O-ring (A) and seat (B) for dirt or defects.
2. Ensure that O-ring (A) is **NOT** on the threads. Adjust O-ring (A) if necessary.
3. Apply hydraulic system oil to the O-ring.
4. Install fitting (C) into the port until the fitting is hand-tight.
5. Torque fitting (C) according to values in Table 11.7, page 137.
6. Verify the final condition of the fitting.

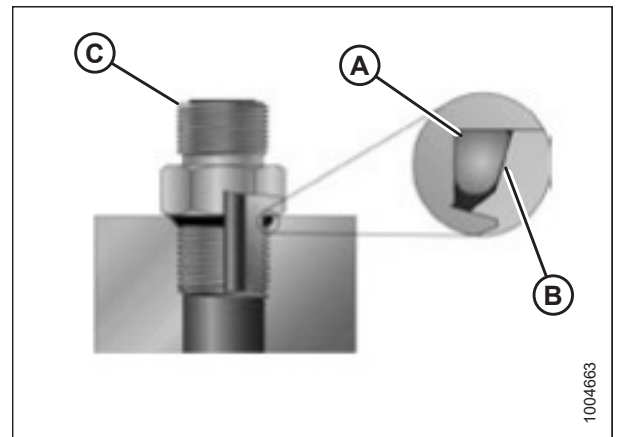

Figure 11.20: Hydraulic Fitting

Table 11.7 O-Ring Boss (ORB) Hydraulic Fittings – Adjustable and Non-Adjustable

SAE Dash Size	Thread Size (in.)	Torque Value ³	
		Nm	lbf-ft (*lbf-in)
-2	5/16–24	10–11	*89–97
-3	3/8–24	18–20	*159–177
-4	7/16–20	29–32	21–24
-5	1/2–20	32–35	24–26

3. Torque values shown are based on lubricated connections as in reassembly.

REFERENCE

Table 11.7 O-Ring Boss (ORB) Hydraulic Fittings – Adjustable and Non-Adjustable (continued)

SAE Dash Size	Thread Size (in.)	Torque Value ⁴	
		Nm	lbf-ft (*lbf-in)
-6	9/16-18	40-44	30-32
-8	3/4-16	70-77	52-57
-10	7/8-14	115-127	85-94
-12	1 1/16-12	183-201	135-148
-14	1 3/16-12	237-261	175-193
-16	1 5/16-12	271-298	200-220
-20	1 5/8-12	339-373	250-275
-24	1 7/8-12	414-455	305-336
-32	2 1/2-12	509-560	375-413

11.4.5 O-Ring Face Seal Hydraulic Fittings

The standard torque values are provided for O-ring face seal hydraulic fittings. If a procedure specifies a different torque value for the same type and size of fitting found in this topic, refer to the value specified in the procedure instead.

Torque values are shown in the Table 11.8, page 139.

1. Ensure that the sealing surfaces and the fitting threads are free of burrs, nicks, scratches, and any foreign material.



Figure 11.21: Hydraulic Fitting

4. Torque values shown are based on lubricated connections as in reassembly.

REFERENCE

2. Apply hydraulic system oil to O-ring (B).
3. Align the tube or hose assembly so that the flat face of sleeve (A) or (C) comes into full contact with O-ring (B).
4. Thread tube or hose nut (D) until it is hand-tight. The nut should turn freely until it bottoms out.
5. Torque the fittings according to values in Table 11.8, page 139.

NOTE:

If applicable, hold the hex flange on fitting body (E) to prevent the rotation of the fitting body and the hose when tightening fitting nut (D).

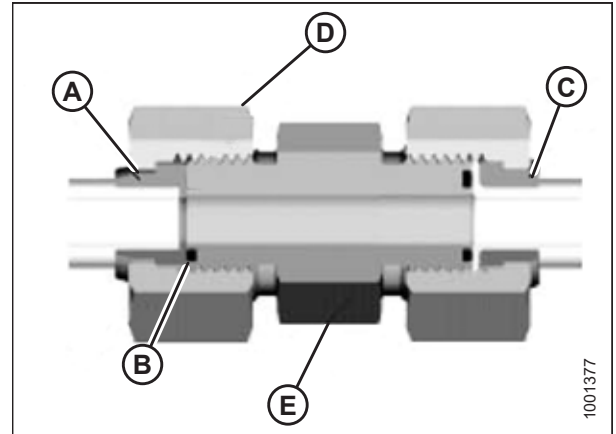

Figure 11.22: Hydraulic Fitting

6. Use three wrenches when assembling unions or joining two hoses together.
7. Verify the final condition of the fitting.

Table 11.8 O-Ring Face Seal (ORFS) Hydraulic Fittings

SAE Dash Size	Thread Size (in.)	Tube O.D. (in.)	Torque Value ⁵	
			Nm	lbf-ft
-3	Note ⁶	3/16	–	–
-4	9/16	1/4	25–28	18–21
-5	Note ⁶	5/16	–	–
-6	11/16	3/8	40–44	30–32
-8	13/16	1/2	55–61	41–45
-10	1	5/8	80–88	59–65
-12	1 3/16	3/4	115–127	85–94
-14	Note ⁶	7/8	–	–
-16	1 7/16	1	150–165	111–122
-20	1 11/16	1 1/4	205–226	151–167
-24	2	1 1/2	315–347	232–256
-32	2 1/2	2	510–561	376–414

11.4.6 Tapered Pipe Thread Fittings

The standard torque values are provided for tapered pipe thread fittings. If a procedure specifies a different torque value for the same type and size of fitting found in this topic, refer to the value specified in the procedure instead.

Assemble pipe fittings as follows:

1. Ensure that the fitting and the port threads are free of burrs, nicks, scratches, and any other form of contamination.
2. Apply paste-type pipe thread sealant to the external pipe threads.
3. Thread the fitting into the port until it is hand-tight.

5. Torque values and angles shown are based on lubricated connection as in reassembly.

6. O-ring face seal type end not defined for this tube size.

REFERENCE

4. Torque the connector to the appropriate torque angle. The turns from finger tight (TFFT) and flats from finger tight (FFFT) values are shown in Table 11.9, page 140. Ensure that the tube end of a shaped connector (typically a 45° or 90° elbow) is aligned to receive the incoming tube or hose assembly. Always finish the alignment of the fitting in the direction of tightening. Never loosen the threaded connectors to achieve alignment.
5. Clean all residue and any excess thread conditioner with an appropriate cleaner.
6. Inspect the final condition of the fitting. Pay special attention to the possibility of cracks in the port opening.
7. Mark the final position of the fitting. If a fitting leaks, disassemble the fitting and check it for damage.

NOTE:

The failure of fittings due to over-torquing may not be evident until the fittings are disassembled and inspected.

Table 11.9 Hydraulic Fitting Pipe Thread

Tapered Pipe Thread Size	Recommended TFFT	Recommended FFFT
1/8-27	2-3	12-18
1/4-18	2-3	12-18
3/8-18	2-3	12-18
1/2-14	2-3	12-18
3/4-14	1.5-2.5	12-18
1-11 1/2	1.5-2.5	9-15
1 1/4-11 1/2	1.5-2.5	9-15
1 1/2-11 1/2	1.5-2.5	9-15
2-11 1/2	1.5-2.5	9-15

11.5 Conversion Chart

This manual uses both SI units (including metric) and US customary units (sometimes referred to as standard units) of measurement. A list of those units along with their abbreviations and conversion factors is provided here for your reference.

Table 11.10 Conversion Chart

Quantity	SI Units (Metric)		Factor	US Customary Units (Standard)	
	Unit Name	Abbreviation		Unit Name	Abbreviation
Area	hectare	ha	x 2.4710 =	acre	acres
Flow	liters per minute	L/min	x 0.2642 =	US gallons per minute	gpm
Force	Newton	N	x 0.2248 =	pound force	lbf
Length	millimeter	mm	x 0.0394 =	inch	in.
Length	meter	m	x 3.2808 =	foot	ft.
Power	kilowatt	kW	x 1.341 =	horsepower	hp
Pressure	kilopascal	kPa	x 0.145 =	pounds per square inch	psi
Pressure	megapascal	MPa	x 145.038 =	pounds per square inch	psi
Pressure	bar (Non-SI)	bar	x 14.5038 =	pounds per square inch	psi
Torque	Newton meter	Nm	x 0.7376 =	pound feet or foot pounds	lbf-ft
Torque	Newton meter	Nm	x 8.8507 =	pound inches or inch pounds	lbf-in
Temperature	degrees Celsius	°C	(°C x 1.8) + 32 =	degrees Fahrenheit	°F
Velocity	meters per minute	m/min	x 3.2808 =	feet per minute	ft/min
Velocity	meters per second	m/s	x 3.2808 =	feet per second	ft/s
Velocity	kilometers per hour	km/h	x 0.6214 =	miles per hour	mph
Volume	liter	L	x 0.2642 =	US gallon	US gal
Volume	milliliter	mL	x 0.0338 =	ounce	oz.
Volume	cubic centimeter	cm ³ or cc	x 0.061 =	cubic inch	in. ³
Weight	kilogram	kg	x 2.2046 =	pound	lb.

REFERENCE

11.6 Definitions

The following terms, abbreviations, and acronyms are used in this instruction.

Table 11.11 Definitions

Term	Definition
API	American Petroleum Institute
Bolt	A headed and externally threaded fastener designed to be paired with a nut
Cab-forward	Windrower operation mode in which the operator's seat faces the header
Center-link	A hydraulic cylinder or manually adjustable turnbuckle type connection between the header and the vehicle, which is used to change the angle of the header relative to the vehicle
CGVW	Combined gross vehicle weight
Export header	The header configuration typical outside North America
FFFT	Flats from finger tight
Finger tight	A reference position in which the given sealing surfaces or components are making contact with each other. The fitting has been tightened by hand to a point where the fitting is no longer loose and cannot be tightened further by hand
GVW	Gross vehicle weight
Hard joint	A joint made with use of a fastener where joining materials are highly incompressible
Header	A machine that cuts and lays crop into a windrow when attached to a windrower
Hex key	A tool of hexagonal cross-section used to drive bolts and screws that have a hexagonal socket in the head (internal-wrenching hexagon drive); also known as an Allen key
JIC	Joint Industrial Council: A standards body that developed standard sizing and shape for the original 37° flared fitting
M Series Windrowers	MacDon M100, M105, M150, M155, M155E4, M200, and M205 Windrowers
M1 Series Windrowers	MacDon M1170, M1170 NT, M1170 NT5, and M1240 Windrowers
M2 Series Windrowers	MacDon M2170, M2170 NT, and M2260 Windrowers
n/a	Not applicable
North American header	The header configuration typical in North America
NPT	National Pipe Thread: A style of fitting used for low-pressure port openings. Threads on NPT fittings are uniquely tapered for an interference fit
Nut	An internally threaded fastener designed to be paired with a bolt
ORB	O-ring boss: A style of fitting commonly used in port openings on manifolds, pumps, and motors
ORFS	O-ring face seal: A style of fitting commonly used for connecting hoses and tubes. This style of fitting is also commonly called ORS, which stands for O-Ring Seal
rpm	Revolutions per minute
SAE	Society of Automotive Engineers
Screw	A headed and externally threaded fastener that threads into preformed threads or forms its own thread when it is inserted into a mating part
Soft joint	A flexible joint made by use of a fastener in which the joining materials compress or relax over a period of time
Tension	An axial load placed on a bolt or screw, usually measured in Newtons (N) or pounds (lb.). This term can also be used to describe the force a belt exerts on a pulley or sprocket
TFFT	Turns from finger tight

REFERENCE

Table 11.11 Definitions (continued)

Term	Definition
Torque	The product of a force * the length of a lever arm, usually measured in Newton-meters (Nm), foot-pounds (lbf·ft), or inch-pounds (lbf·in)
Torque angle	A tightening procedure in which a fitting is assembled to a specified tightness (usually finger tight) and then the nut is turned farther by a specified number of degrees until it achieves its final position
Torque-tension	The relationship between the assembly torque applied to a piece of hardware and the axial load it induces in a bolt or screw
Washer	A thin cylinder with a hole or a slot located in the center, used as a spacer, a load distribution element, or a locking mechanism
Windrower	The power unit for a header

Predelivery Checklist

Perform these checks and adjustments before delivering the machine to your Customer. If adjustments are required, refer to the appropriate page number in this manual. The completed Checklist should be retained by either the Operator or the Dealer.

WARNING

Do NOT operate the machine with the driveshields open. High speed rotating components may throw debris and could result in death or serious injury.

CAUTION

Carefully follow the instructions given. Be alert for safety-related messages that bring your attention to hazards and unsafe practices.

Serial Number:

Table .12 Predelivery Checklist

✓	Item	Reference
	Check for shipping damage or missing parts. Be sure all shipping dunnage is removed.	—
	Check for loose hardware. Tighten to required torque if applicable.	<i>11.4 Torque Specifications, page 133</i>
	Check main drive belt tension.	<i>10.1.1 Checking and Adjusting Conditioner Drive Belt, page 114</i>
	Check skid shoes are evenly set.	<i>10.1.2 Checking Skid Shoes, page 114</i>
	Check side forming shields evenly set to desired position.	<i>10.1.3 Checking and Adjusting Forming Shield Deflector Position, page 115</i>
	Check rear baffle is about mid-position.	<i>10.1.10 Adjusting Conditioner Baffle Position, page 123</i>
	Check conditioner roll gap (roll conditioner).	<i>10.1.7 Checking and Adjusting Roll Gap, page 122</i>
	Check conditioner roll tension (roll conditioner).	<i>10.1.9 Checking and Adjusting Roll Tension, page 123</i>
	Check conditioner roll timing hardware is securely tightened (roll conditioner).	<i>10.1.8 Checking Roll Timing, page 123</i>
	Check that cutterbar doors are unbolted from centre channel frame, shipping wire is removed from cutterbar curtains, and cutterbar curtains are hanging properly.	<i>7 Unpacking Curtains, page 107</i>
	Grease all bearings and drivelines.	<i>9.1 Lubrication Locations, page 112</i>
	Check conditioner roll timing gearbox lubricant.	<i>10.1.5 Checking and Adding Lubricant – Conditioner Roll Timing Gearbox, page 121</i>
	Check cutterbar lubricant.	<i>10.1.15 Checking and Adding Lubricant – Cutterbar, page 125</i>

REFERENCE

Table .12 Predelivery Checklist (continued)

✓	Item	Reference
	<p>Check cutterbar area carefully for loose parts and hardware on the cutterbar.</p> <p> WARNING</p> <p>These objects can be ejected with considerable force when the machine is started, and may result in serious injury or machine damage.</p>	—
Run-Up Procedure		
	Check hydraulic hose and wiring harness routing to ensure adequate clearance when raising or lowering header.	—
	Check hazard lights are functional.	<i>10.1.11 Checking Lights, page 124</i>
Post Run-Up Check – Stop Engine		
	Check belt drive for proper idler alignment and overheating bearings.	<i>10.1.1 Checking and Adjusting Conditioner Drive Belt, page 114</i>
	Check for hydraulic leaks.	—
	Check that header manuals are in storage compartment.	<i>10.1.12 Checking Manuals, page 124</i>
	Ensure that timing tool and spindle nut wrench are stored on the panel at the left end of the header.	<i>10.1.13 Checking Disc Timing Tool, page 125</i>

Date Checked:

Checked by:

Recommended Lubricants

Keep your machine operating at top efficiency by using only clean lubricants and by ensuring the following:

- Use clean containers to handle all lubricants.
- Store lubricants in an area protected from dust, moisture, and other contaminants.

IMPORTANT:

Do **NOT** overfill the cutterbar when adding lubricant. Overfilling could result in overheating and failure of cutterbar components.

Specification	Description	Use	Capacities
Lubricant: Grease			
SAE Multipurpose	High-temperature, extreme-pressure (EP) performance with 1% max. molybdenum disulphide (NLGI Grade 2) lithium base	As required unless otherwise specified	—
SAE Multipurpose	High-temperature, extreme-pressure (EP) performance with 10% max. molybdenum disulphide (NLGI Grade 2) lithium base	Driveline slip-joints	—
Lubricant: Gear Lubricant			
SAE 80W-90	High thermal and oxidation stability API service class GL-5		8 L (8.5 qts [US])
SAE 85W-140	Fully synthetic oil API GL-5 minimum, SAE J2360 preferred	Conditioner roll timing gearbox	0.7 L (0.75 qts [US])
SAE 80W-140	Fully synthetic oil API GL-5 minimum, SAE J2360 preferred	Header drive 90° gearbox	1.65 L (1.74 qts [US])

MacDon®

CUSTOMERS
MacDon.com

DEALERS
Portal.MacDon.com

Trademarks of products are the marks of their
respective manufacturers and/or distributors.

Printed in Canada