

MacDon™

M105 Self-Propelled Windrower

**UNLOADING and ASSEMBLY
INSTRUCTIONS
for
NORTH AMERICAN SHIPMENTS**



MACDON M105 SELF PROPELLED WINDROWER

CALIFORNIA

Proposition 65 Warning

Diesel engine exhaust and some of its constituents are known to the State of California to cause cancer, birth defects, and other reproductive harm.

INTRODUCTION

This instructional manual describes the unloading, set-up and pre-delivery requirements for the MacDon M105 Self-Propelled Windrower. Use the Table of Contents to guide you to specific areas. Retain this instruction for future reference.

CAREFULLY READ ALL THE MATERIAL PROVIDED BEFORE ATTEMPTING TO UNLOAD, ASSEMBLE, OR USE THE MACHINE.

TABLE OF CONTENTS

Title	Page
INTRODUCTION	1
GENERAL SAFETY	2
RECOMMENDED TORQUES	4
A. GENERAL.....	4
B. SAE BOLTS	4
C. METRIC BOLTS.....	4
D. HYDRAULIC FITTINGS.....	5
CONVERSION CHART	7
DEFINITIONS	8
STEP 1. UNLOAD WINDROWER	9
A. TWO FORKLIFT METHOD.....	9
B. SINGLE FORKLIFT METHODS	10
STEP 2. RE-POSITION RH LEG (BOLTED FRAME)	12
STEP 3. INSTALL FRONT WHEELS	13
STEP 4. INSTALL CASTER WHEELS (FIXED FRAME)	14
STEP 5. RE-POSITION CASTER WHEELS (BOLTED FRAME)	16
STEP 6. INSTALL STEPS	17
STEP 7. INSTALL CENTER-LINK	17
STEP 8. INSTALL BATTERIES	18
STEP 9. INSTALL AM/FM RADIO	19
STEP 10. ATTACH HEADER	21
A. HEADER ATTACHMENT - D SERIES	21
B. HEADER ATTACHMENT - A SERIES.....	26
STEP 11. LUBRICATE MACHINE	29
STEP 12. PROGRAM CDM	31
STEP 13. PERFORM PRE- DELIVERY CHECKS	37
A. SERIAL NUMBERS	37
B. FINAL DRIVE LUBRICANT LEVEL	37
C. TIRE PRESSURES.....	37
D. ENGINE COOLANT	37
E. AIR CLEANER	38
F. HYDRAULIC OIL LEVEL	38
G. FUEL SEPARATOR.....	38
H. A/C COMPRESSOR BELT	39
I. PERFORM SAFETY SYSTEM CHECKS	40
J. OPERATIONAL CHECKS	41
K. SET KNIFE SPEED	46
L. MANUALS.....	47
M. CAB INTERIOR.....	47

GENERAL SAFETY



CAUTION

The following are general farm safety precautions that should be part of your operating procedure for all types of machinery.

- Protect yourself.
- When assembling, operating and servicing machinery, wear all the protective clothing and personal safety devices that **COULD** be necessary for the job at hand. Don't take chances.
- You may need:

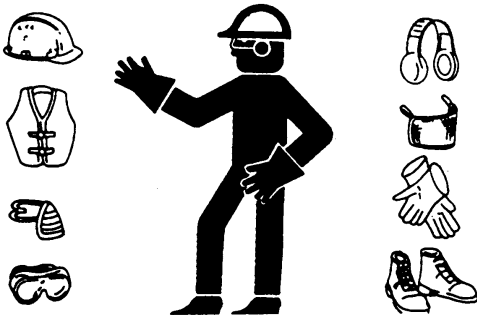

- a hard hat.
- protective shoes with slip resistant soles.
- protective glasses or goggles.
- heavy gloves.
- wet weather gear.
- respirator or filter mask.

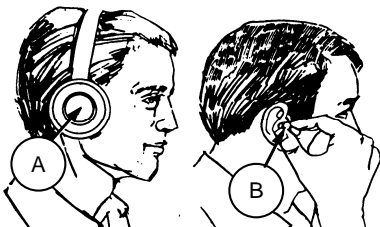

- hearing protection. Be aware that prolonged exposure to loud noise can cause impairment or loss of hearing. Wearing a suitable hearing protective device such as ear muffs (A) or ear plugs (B) protects against objectionable or loud noises.
- Keep young children away from machinery at all times.



- Provide a first-aid kit for use in case of emergencies.
- Keep a fire extinguisher on the machine. Be sure the extinguisher is properly maintained and be familiar with its proper use.
- Be aware that accidents often happen when the Operator is tired or in a hurry to get finished. Take the time to consider the safest way. Never ignore warning signs of fatigue.
- Wear close-fitting clothing and cover long hair. Never wear dangling items such as scarves or bracelets.
- Keep hands, feet, clothing and hair away from moving parts. Never attempt to clear obstructions or objects from a machine while the engine is running.

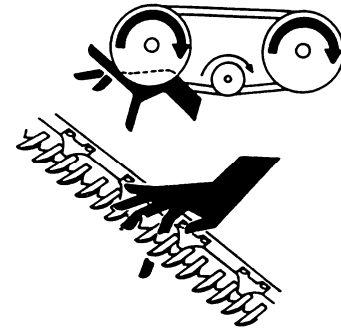

- Keep all shields in place. Never alter or remove safety equipment. Make sure driveline guards can rotate independently of the shaft and can telescope freely.
- Use only service and repair parts made or approved by the equipment manufacturer. Substituted parts may not meet strength, design, or safety requirements.
- Do not modify the machine. Unauthorized modifications may impair the function and/or safety and affect machine life.

(continued next page)

GENERAL

- Stop engine, and remove key from ignition before leaving Operator's seat for any reason. A child or even a pet could engage an idling machine.



- Keep the area used for servicing machinery clean and dry. Wet or oily floors are slippery. Wet spots can be dangerous when working with electrical equipment. Be sure all electrical outlets and tools are properly grounded.
- Use adequate light for the job at hand.
- Keep machinery clean. Do not allow oil or grease to accumulate on service platforms, ladders or controls. Clean machines before storage.
- Never use gasoline, naphtha or any volatile material for cleaning purposes. These materials may be toxic and/or flammable.
- When storing machinery, cover sharp or extending components to prevent injury from accidental contact.

GENERAL

RECOMMENDED TORQUES

A. GENERAL

The tables shown below give correct torque values for various bolts and capscrews.

- Tighten all bolts to the torques specified in chart, unless otherwise noted throughout this manual.
- Check tightness of bolts periodically, using bolt torque chart as a guide.
- Replace hardware with the same strength bolt.
- Torque figures are valid for non-greased or non-oiled threads and heads unless otherwise specified. Do not grease or oil bolts or capscrews unless specified in this manual.
- When using locking elements, increase torque values by 5%.

B. SAE BOLTS

BOLT DIA. "A" (in.)	NC BOLT TORQUE*			
	SAE-5		SAE-8	
	lbf-ft	N-m	lbf-ft	N-m
1/4	9	12	11	15
5/16	18	24	25	34
3/8	32	43	41	56
7/16	50	68	70	95
1/2	75	102	105	142
9/16	110	149	149	202
5/8	150	203	200	271
3/4	265	359	365	495
7/8	420	569	600	813
1	640	867	890	1205

* Torque categories for bolts and capscrews are identified by their head markings.

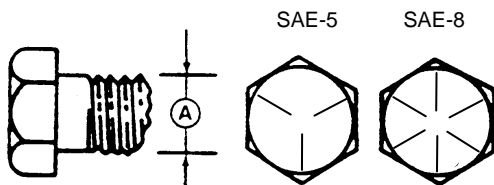

C. METRIC BOLTS

BOLT DIA. "A"	STD COARSE BOLT TORQUE*			
	8.8		10.9	
	lbf-ft	N-m	lbf-ft	N-m
M3	0.4	0.5	1.3	1.8
M4	2.2	3	3.3	4.5
M5	4	6	7	9
M6	7	10	11	15
M8	18	25	26	35
M10	37	50	52	70
M12	66	90	92	125
M14	103	140	148	200
M16	166	225	229	310
M20	321	435	450	610
M24	553	750	774	1050
M30	1103	1495	1550	2100
M36	1917	2600	2710	3675

* Torque categories for bolts and capscrews are identified by their head markings.

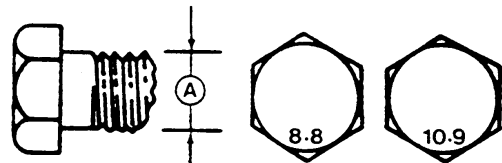

GENERAL

D. HYDRAULIC FITTINGS

FLARE TYPE

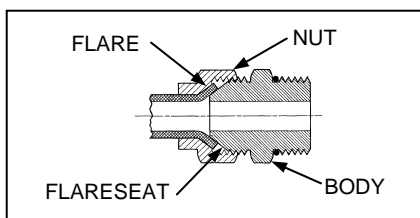

- a. Check flare and flare seat for defects that might cause leakage.
- b. Align tube with fitting before tightening.
- c. Lubricate connection, and hand-tighten swivel nut until snug.
- d. To prevent twisting the tube(s), use two wrenches. Place one wrench on the connector body, and with the second, tighten the swivel nut to the torque shown.

SAE NO.	TUBE SIZE O.D. (in.)	THD SIZE (in.)	NUT SIZE ACROSS FLATS (in.)	TORQUE VALUE*		RECOMMENDED TURNS TO TIGHTEN (AFTER FINGER TIGHTENING)	
				ft-lbf	N-m	Flats	Turns
3	3/16	3/8	7/16	6	8	1	1/6
4	1/4	7/16	9/16	9	12	1	1/6
5	5/16	1/2	5/8	12	16	1	1/6
6	3/8	9/16	11/16	18	24	1	1/6
8	1/2	3/4	7/8	34	46	1	1/6
10	5/8	7/8	1	46	62	1	1/6
12	3/4	1-1/16	1-1/4	75	102	3/4	1/8
14	7/8	1-3/16	1-3/8	90	122	3/4	1/8
16	1	1-5/16	1-1/2	105	142	3/4	1/8

* Torque values shown are based on lubricated connections as in re-assembly.

O-RING TYPE

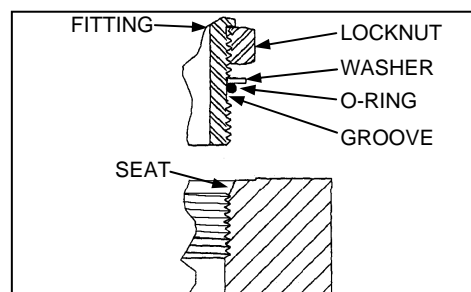

- a. Inspect O-ring, and seat for dirt or obvious defects.

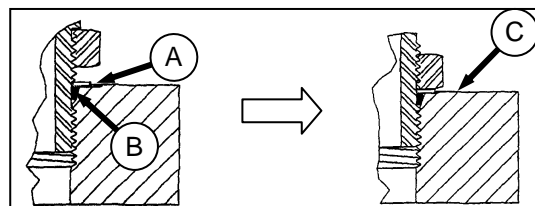

- b. On angle fittings, back off the lock nut until washer (A) bottoms out at top of groove (B) in fitting.
- c. Hand-tighten fitting until back up washer (A) or washer face (if straight fitting) bottoms on part face (C), and O-ring is seated.
- d. Position angle fittings by unscrewing **no more than** one turn.
- e. Tighten straight fittings to torque shown.
- f. Tighten angle fittings to torque shown in the following table, while holding body of fitting with a wrench.

SAE NO.	THD SIZE (in.)	NUT SIZE ACROSS FLATS (in.)	TORQUE VALUE*		RECOMMENDED TURNS TO TIGHTEN (AFTER FINGER TIGHTENING)	
			ft-lbf	N-m	Flats	Turns
3	3/8	1/2	6	8	2	1/3
4	7/16	9/16	9	12	2	1/3
5	1/2	5/8	12	16	2	1/3
6	9/16	11/16	18	24	2	1/3
8	3/4	7/8	34	46	2	1/3
10	7/8	1	46	62	1-1/2	1/4
12	1-1/16	1-1/4	75	102	1	1/6
14	1-3/16	1-3/8	90	122	1	1/6
16	1-5/16	1-1/2	105	142	3/4	1/8
20	1-5/8	1-7/8	140	190	3/4	1/8
24	1-7/8	2-1/8	160	217	1/2	1/12

* Torque values shown are based on lubricated connections as in re-assembly.

GENERAL

O-RING FACE SEAL (ORFS) HYDRAULIC FITTINGS

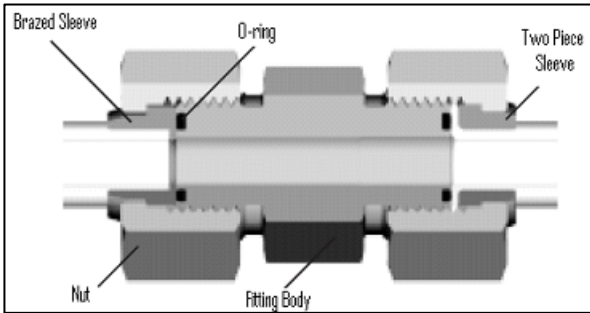
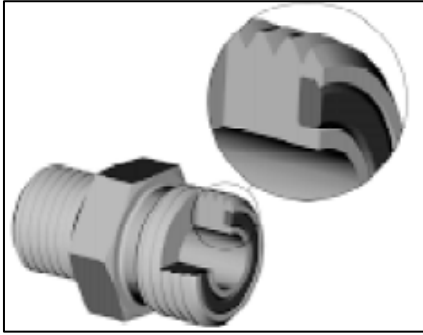

- a. Check components to ensure that the sealing surfaces and fitting threads are free of burrs, nicks, and scratches, or any foreign material.
- b. Apply lubricant (typically Petroleum Jelly) to O-ring and threads. If O-ring is not already installed, install O-ring. Align the tube or hose assembly.
- c. Ensure that flat face of the mating flange comes in full contact with O-ring.
- d. Thread tube or hose nut until hand-tight. The nut should turn freely until it is bottomed out. Torque fitting further to the specified number of F.F.F.T ("Flats From Finger Tight"), or to a given torque value in the table shown in the opposite column.

NOTE

If available, always hold the hex on the fitting body to prevent unwanted rotation of fitting body and hose when tightening the fitting nut.

- e. When assembling unions or two hoses together, three wrenches will be required.

SAE NO.	THD SIZE (in.)	TUBE O.D. (in.)	TORQUE VALUE*		RECOMMENDED TURNS TO TIGHTEN (AFTER FINGER TIGHTENING)**	
			ft-lbf	N-m	Tube Nuts	Swivel & Hose
3	***	3/16	---	---	---	---
4	9/16	1/4	11 - 12	14 - 16	1/4 - 1/2	1/2 - 3/4
5	***	5/16	---	---	---	---
6	11/16	3/8	18 - 20	24 - 27	1/4 - 1/2	1/2 - 3/4
8	13/16	1/2	32 - 35	43 - 47		
10	1	5/8	45 - 51	60 - 68		
12	1-3/16	3/4	67 - 71	90 - 95		1/3 - 1/2
14	1-3/16	7/8	67 - 71	90 - 95		
16	1-7/16	1	93 - 100	125 - 135		
20	1-11/16	1-1/4	126 - 141	170 - 190		
24	2	1-1/2	148 - 167	200 - 225	---	---
32	2-1/2	2	---	---	---	---

* Torque values and angles shown are based on lubricated connection, as in re-assembly.

** Always default to the torque value for evaluation of adequate torque.

*** O-ring face seal type end not defined for this tube size.

GENERAL

CONVERSION CHART

QUANTITY	INCH-POUND UNITS		FACTOR	SI UNITS (METRIC)	
	UNIT NAME	ABBR.		UNIT NAME	ABBR.
Area	acres	acres	x 0.4047 =	hectares	ha
Flow	gallons per minute (US) gallons per minute (Imp)	gpm (US) gpm	x 3.7854 = x 4.5460 =	liters per minute	L/min
Force	pounds force	lbf	x 4.4482 =	Newtons	N
Length	inch	in.	x 25.4 =	millimeters	mm
	foot	ft	x 0.305 =	meters	m
Power	horsepower	hp	x 0.7457 =	kilowatts	kW
Pressure	pounds per square inch	psi	x 6.8948 =	kilopascals	kPa
			x .00689 =	megapascals	MPa
Torque	pound feet or foot pounds	lbf-ft or ft-lbf	x 1.3558 =	newton meters	N·m
	pound inches or inch pounds	lbf-in. or in-lbf	x 0.1129 =		
Temperature	degrees Fahrenheit	°F	(°F - 32) x 0.56 =	Celsius	°C
Velocity	feet per minute	ft/min	x 0.3048 =	meters per minute	m/min
	feet per second	ft/s	x 0.3048 =	meters per second	m/s
	miles per hour	mph	x 1.6063 =	kilometers per hour	km/h
Volume	ounces	oz.	x 29.5735 =	milliliters	ml
	cubic inches	in. ³	x 16.3871 =	cubic centimeters	cm ³ or cc
	quarts (US) quarts (Imperial)	US qt. qt.	x 0.96464 x 1.1365	liters	L
	gallons (US) gallons (Imperial)	US gal. gal.	x 3.7854 = x 4.5460 =		
Weight	pounds	lb	x 0.4536 =	kilograms	kg

GENERAL

DEFINITIONS

The following terms/abbreviations may be used in this manual:

TERM	DEFINITION
API	American Petroleum Institute
APT	Articulating Power Tongue
ASTM	American Society Of Testing and Materials
Cab-Forward	Windrower operation with the Operator and cab facing in the direction of travel.
CDM	Cab Display Module
Center-link	A hydraulic cylinder or turnbuckle type link between the header and the machine that tilts the header.
ECM	Engine Control Module.
GSL	Ground Speed Lever
Header	A machine that cuts and lays crop into a windrow, and is attached to a self-propelled windrower.
ISC	Intermediate Speed Control.
Mower Conditioner	A machine that cuts and conditions hay, and is pulled by an Ag tractor.
PTO	Power Take-Off
SAE	Society Of Automotive Engineers
Self-Propelled Windrower (SP)	Self-propelled machine consisting of a power unit with a header and/or conditioner.
Tractor	Ag type tractor.
Truck	A four-wheel highway/road vehicle weighing no less than 7500 lb (3400 kg).
Windrower	Power unit of a self-propelled header.
WCM	Windrower Control Module

UNLOADING AND ASSEMBLY

STEP 1. UNLOAD WINDROWER



CAUTION

To avoid injury to bystanders from being struck by machinery, do not allow persons to stand in unloading area.

A. TWO FORKLIFT METHOD



CAUTION

Equipment used for unloading must meet or exceed the requirements specified below. Using inadequate equipment may result in chain breakage, vehicle tipping or machine damage.

LIFTING VEHICLE	
Minimum Capacity *	5500 lb (2500 kg)
Minimum Fork Length	78 in. (1981 mm)

* At 48 in. (1220 mm) from back end of forks.

IMPORTANT

Forklifts are normally rated for a load located 24 in. (610 mm) ahead of back end of the forks.

To obtain the forklift capacity at 48 in. (1220 mm), check with your forklift distributor.

- Move trailer onto level ground, and block trailer wheels.
- Set forklift tines to the widest possible setting.



BOLTED FRAME SHOWN
FIXED FRAME SIMILAR

- Position one forklift on either side of trailer, and locate forks under windrower frame.

NOTE

Windrower center of gravity is approximately 55 in. (1397 mm) rearward of drive wheel center.

- Lift with both forklifts simultaneously until windrower is clear of trailer bed.



WARNING

Be sure forks are secure before moving trailer away from load. Stand clear when lifting.

- Drive the truck slowly forward until trailer bed is clear of windrower.
- Lower unit slowly and simultaneously with both forklifts to the ground. If ground is soft, place wooden blocks under front shipping stands.
- Back off forklifts.
- Check windrower for shipping damage, and check shipment for missing parts.

UNLOADING AND ASSEMBLY

B. SINGLE FORKLIFT METHODS

There are two methods that can be used:

I. METHOD 1



CAUTION

Equipment used for unloading must meet or exceed the requirements specified below. Using inadequate equipment may result in chain breakage, vehicle tipping or machine damage.

LIFTING VEHICLE	
Minimum Capacity *	5500 lb (2500 kg)

* At 48 in. (1220 mm) from back end of forks.

IMPORTANT

Forklifts are normally rated for a load located 24 in. (610 mm) ahead of back end of the forks.

To obtain the forklift capacity at 48 in. (1220 mm), check with your forklift distributor.

CHAIN	
Type	Overhead Lifting Quality (1/2 inch)
Minimum Working Load	5000 lb (2270 kg)

- a. Position rear of trailer against unloading dock that is the same height or slightly lower than the trailer bed.
- b. Remove shipped parts from under windrower frame.
- c. Set forklift tines to widest possible setting.

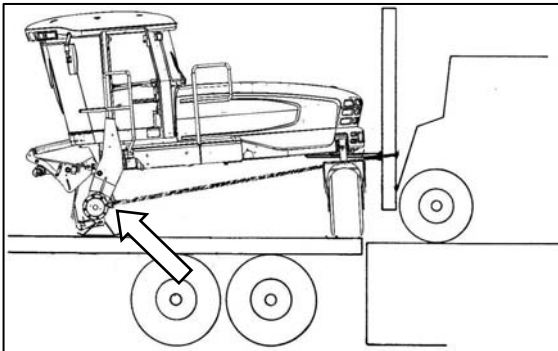

- d. Drive forklift up to rear of windrower, and place forks under the rear frame cross member.

- e. Install chains from forklift mast to jacking brackets on both front legs of windrower.
- f. Chains must be the same length.



CAUTION

The front legs rest on the trailer bed on skid shoes. Ensure there are no obstructions to prevent rearward sliding of the skid shoes, and watch carefully that as unit is dragged, the skid shoes are not sliding sideways towards the edge of the trailer bed.

- g. Drag windrower rearward off of carrier.
- h. Remove chains, and back off the forklift.
- i. Check windrower for shipping damage, and check shipment for missing parts.

II. METHOD 2



CAUTION

Equipment used for unloading must meet or exceed the requirements specified below. Using inadequate equipment may result in chain breakage, vehicle tipping or machine damage.

LIFTING VEHICLE	
Minimum Capacity *	11000 lb (4994 kg)
Minimum Fork Length	78 in. (1981 mm)

* At 48 in. (1220 mm) from back end of forks.

IMPORTANT

Forklifts are normally rated for a load located 24 in. (610 mm) ahead of back end of the forks.

To obtain the forklift capacity at 48 in. (1220 mm), check with your forklift distributor.



WARNING

Be sure forks are secure before moving away from load. Stand clear when lifting.

- a. Move trailer onto level ground, and block trailer wheels.
- b. Set forklift tines to the widest possible setting.

(continued next page)

UNLOADING AND ASSEMBLY



BOLTED FRAME SHOWN
FIXED FRAME SIMILAR

- c. Position forklift on left or right side of trailer, and locate forks under windrower frame.

NOTE

Windrower center of gravity is approximately 55 in. (1397 mm) rearward of drive wheel center.



WARNING

Ensure forks project beyond far side of frame.

- d. Lift until windrower is clear of trailer bed.
- e. Slowly back forklift away from trailer until windrower is clear of trailer.
- f. Lower unit slowly to the ground. If ground is soft, place wooden blocks under front shipping stands.
- g. Back off forklift.
- h. Check windrower for shipping damage, and check shipment for missing parts.

UNLOADING AND ASSEMBLY

STEP 2. RE-POSITION RH LEG (BOLTED FRAME)

For a Fixed Frame windrower, proceed to STEP 3. INSTALL FRONT WHEELS.

For a Bolted Frame windrower, the right cab-forward leg requires re-positioning from shipping to field configuration as follows:

- a. Support front of the windrower leg off the ground with stand (or equivalent).

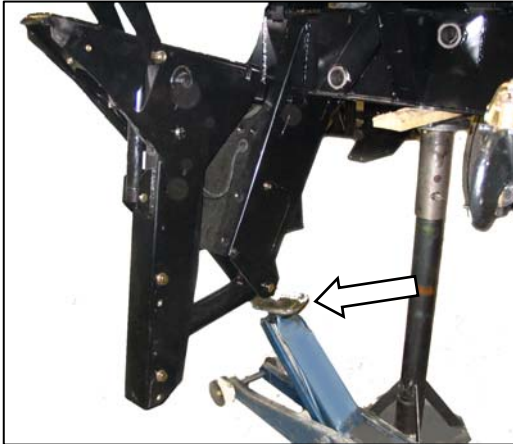

- b. Locate jack under RH leg, and raise jack slightly to take some weight off leg.

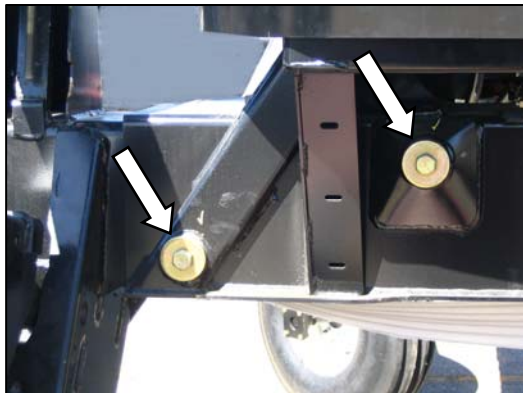

- c. Remove two bolts, washers, and nuts from frame.



- d. Tap out the two pins with a hammer.

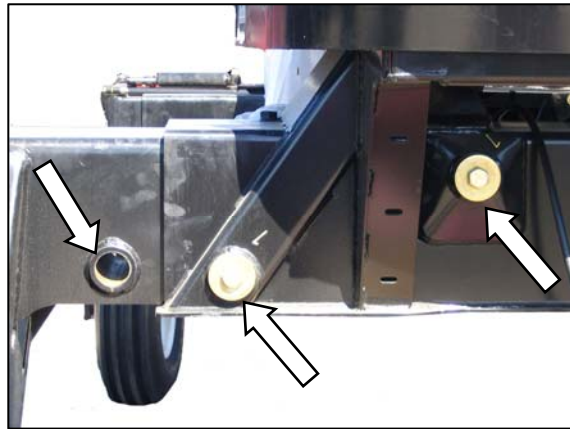

- e. Move leg out to expose one hole.
- f. Re-install pins, and secure with bolts, washers, and nuts (not shown). Torque nuts to 100 ft·lbf (136 N·m).
- g. Lower jack, and remove it from RH leg.

UNLOADING AND ASSEMBLY

STEP 3. INSTALL FRONT WHEELS

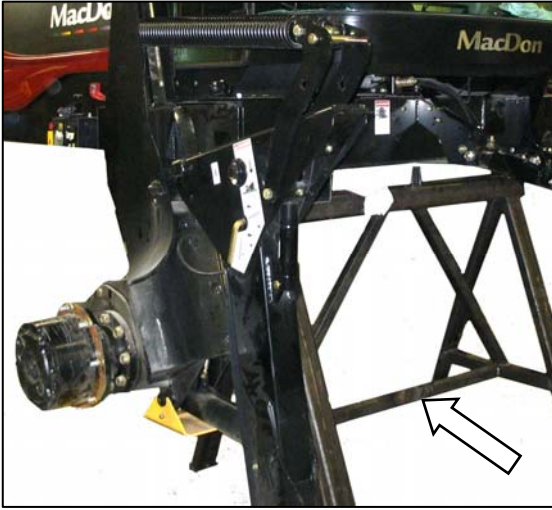

- a. Support the front of the windrower off the ground with stand(s).

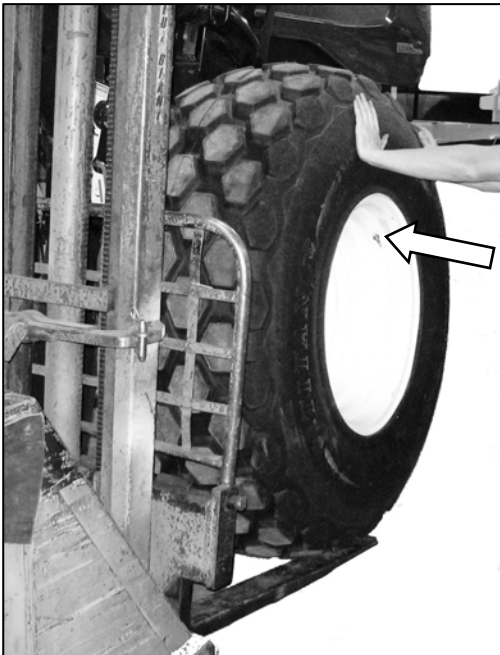

- b. Place wheel against hub so that air valves are on outside, and tire tread points forward.
For "Turf" tires (diamond tread), be sure arrow on sidewall points in forward rotation.
- c. Lift wheel on hub with a forklift (or equivalent). Lower forklift.
- d. Rotate wheel to align holes with studs, and push wheel onto studs.

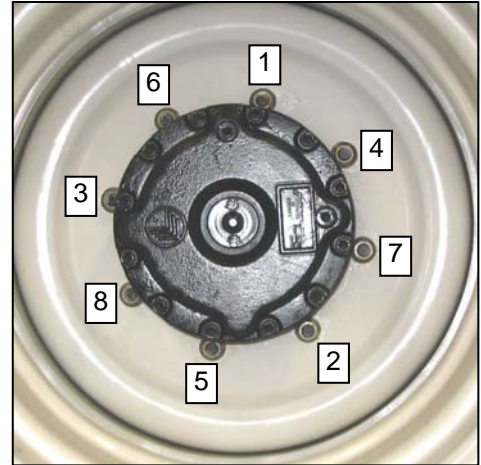

- e. Install wheel nuts, and tighten to 175 - 200 ft-lbf (237 - 271 N-m), using the tightening sequence shown above.

NOTE

To avoid damage to wheel disks, do not over-tighten wheel nuts.

- f. Repeat sequence three times.
- g. Repeat above steps b. to f. for opposite wheel.
- h. Remove stand(s), and lower windrower to ground.

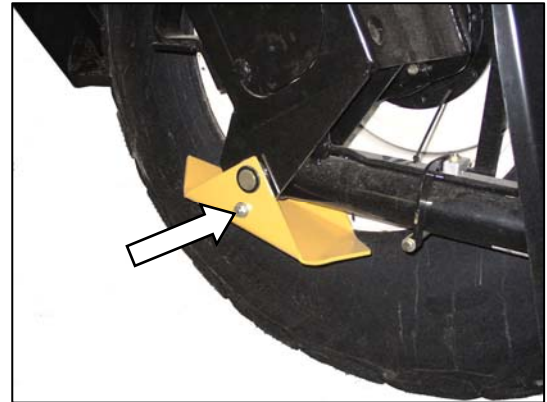

BOLTED FRAME SHIPPING SKID
BOTH SIDES

- i. Remove bolt and shipping skid on LH and RH leg. Discard.
- j. **For Bolted Frame windrower**, proceed to STEP 5. RE-POSITION CASTER WHEELS (BOLTED FRAME)
- k. **For Fixed Beam windrower**, proceed to STEP 4. INSTALL CASTER WHEELS (FIXED FRAME).

UNLOADING AND ASSEMBLY

STEP 4. INSTALL CASTER WHEELS (FIXED FRAME)

There are two methods that can be used:

I. METHOD 1

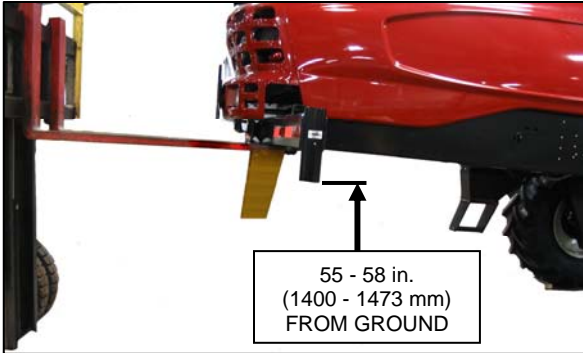

- a. Support rear of windrower with a forklift (or equivalent).

Distance between walking beam and ground should be 55 - 58 in. (1400 - 1473 mm).



- b. Position caster spindle into walking beam.

NOTE

Install formed caster wheels so that in forward operation, the caster spindle is on the outboard side of the wheel.

- c. Slowly lower rear of windrower, while manoeuvring caster so that spindle slides freely into walking beam.

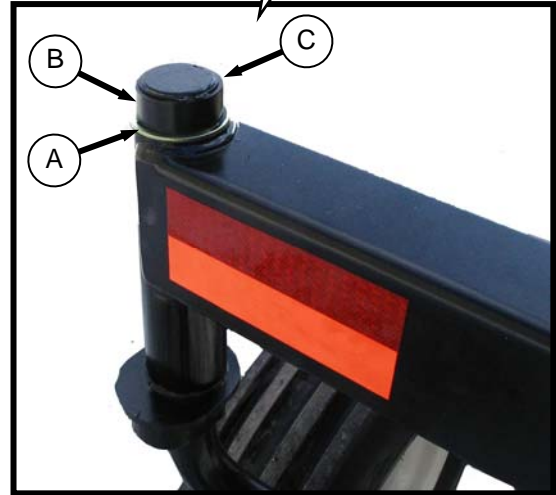

- d. Secure caster in walking beam with washer (A), bushing (B), and clip (C).
- e. Raise rear of windrower again, and repeat above steps for other caster.

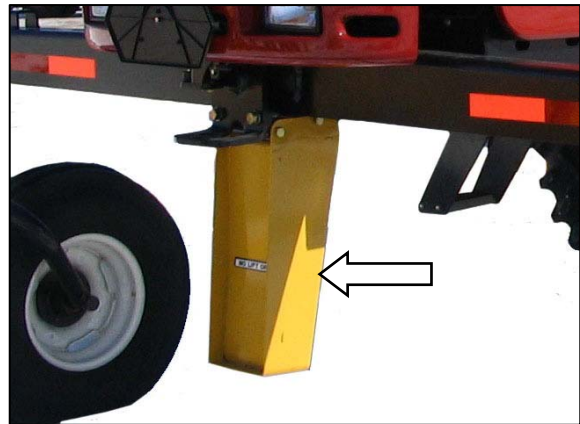

- f. Remove rear shipping stand.
- g. Proceed to STEP 6. INSTALL STEPS.

(continued on next page)

UNLOADING AND ASSEMBLY

II. METHOD 2



- a. Support rear of windrower with jack stands under the rear frame, or with a support under the shipping stand.

Distance between walking beam and ground should be 55 - 58 in. (1400 -1473 mm).

IMPORTANT

The support(s) must be capable of supporting 5000 lb (2270 kg).



- b. Attach a sling around caster, and the other end to a lifting device.

NOTE

Install formed caster wheels so that in forward operation, the caster spindle is on the outboard side of the wheel.

- c. Hoist caster into position, and locate caster spindle into walking beam.
- d. Slowly raise caster while manoeuvring caster so that spindle slides freely into walking beam.

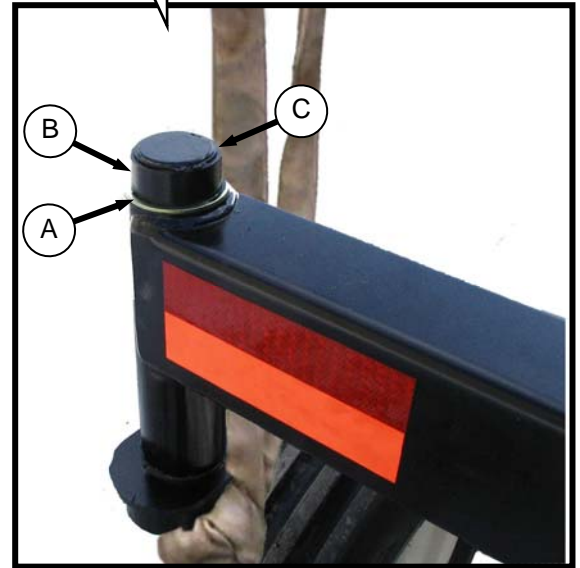

- e. Secure caster in walking beam with washer (A), bushing (B), and clip (C).
- f. Lower lifting device, and remove sling.
- g. Repeat above steps for other caster.
- h. Raise rear of windrower so that stand can be removed, and lower windrower to the ground.

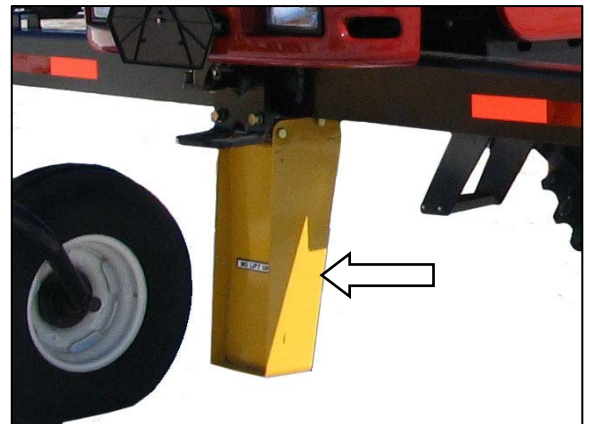

- i. Remove rear shipping stand.
- j. Proceed to STEP 6. INSTALL STEPS.

UNLOADING AND ASSEMBLY

STEP 5. RE-POSITION CASTER WHEELS (BOLTED FRAME)

As an option, the rear casters can be adjusted to a narrow tread width to allow loading and shipping without having to remove them.

A narrow tread width also suits smaller headers by allowing more space to the uncut crop, and provides more maneuverability around poles, irrigation inlets, or other obstacles.

A wider tread width is useful in heavy crops that produce large windrows so that run-over is reduced.

- a. Raise rear of windrower slightly so that most of the weight is off the casters, using a jack or other lifting device under the frame where shown.

NOTE

Lifting device should have a lifting capacity of at least 5000 lb (2270 kg).

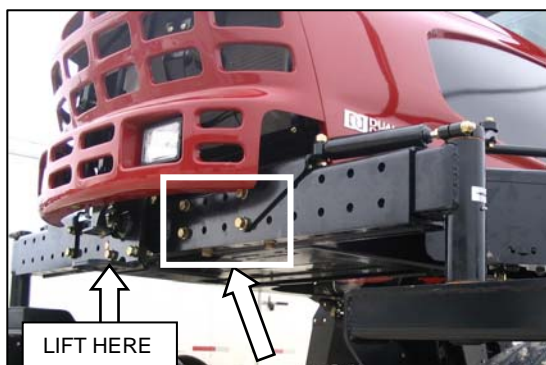

- b. Remove six bolts (four on backside, two on underside) and washers from left and right side of walking beam.



- c. Slide extensions outboard equal amounts, and align holes at desired location.

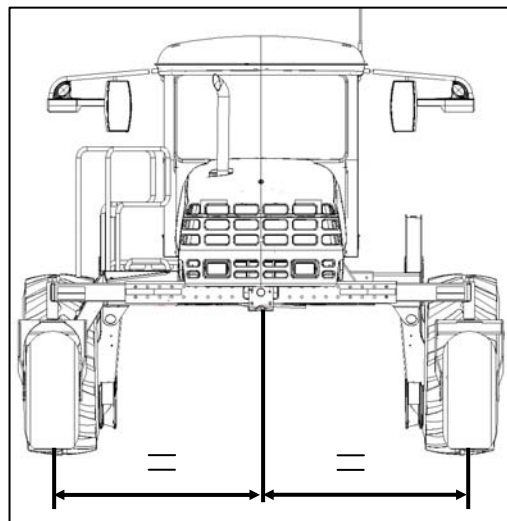

WIDEST TREAD WIDTH SHOWN

IMPORTANT

Caster wheels must be equi-distant from center of windrower.

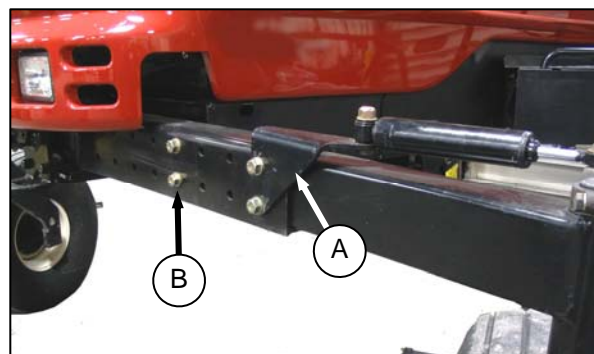

- d. Position bracket (A), and install bolts. The two shorter bolts (B) are installed at the back inboard locations. Torque as follows:
 1. Snug bottom bolts.
 2. Tighten and torque back bolts to 330 ft·lbf (447 N·m).
 3. Tighten and torque bottom bolts to 330 ft·lbf (447 N·m).
- e. Lower windrower to ground.

IMPORTANT

Re-torque bolts after first 5, and 10 hours of operation.

UNLOADING AND ASSEMBLY

STEP 6. INSTALL STEPS

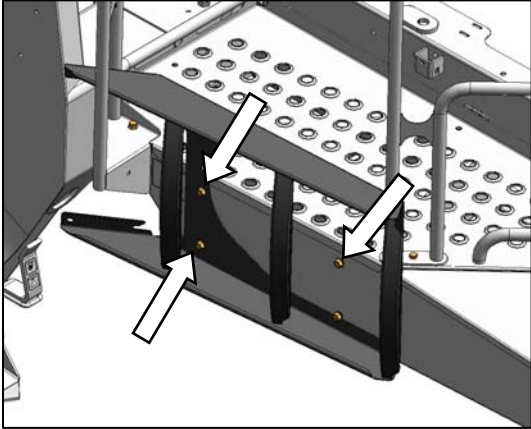

- a. Remove two bolts securing steps to platform, and remove steps.
- b. Remove the one existing upper bolt.

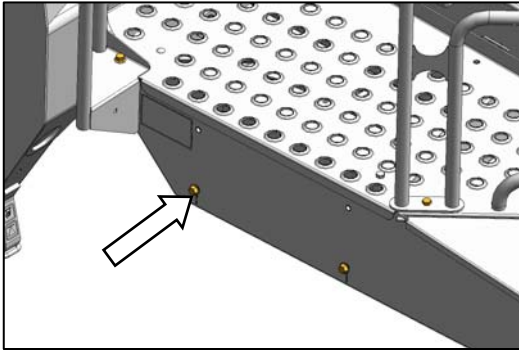

- c. Re-install one bolt in lower hole in platform. Do not thread in fully.
- d. Hang step assembly on bolts. If required, back off bolts.

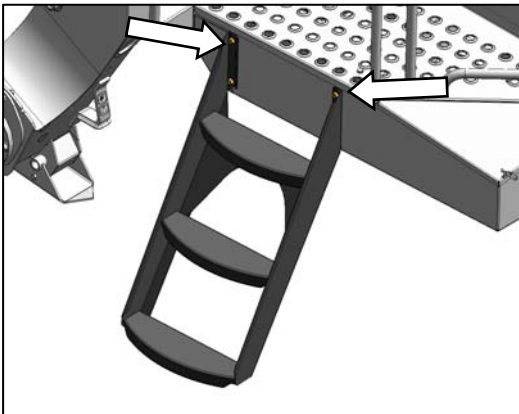

- e. Install two remaining bolts in upper holes in step, and tighten.
- f. Tighten upper bolts installed in step a.

STEP 7. INSTALL CENTER-LINK MECHANICAL LINK

- a. Remove clevis pin from center-link.



- b. Position link between mounting brackets on front frame, and attach at lower hole location.
- c. Install clevis pin, and secure with hair pin.

HYDRAULIC LINK - OPTIONAL



The hydraulic center-link is supplied in a separate kit that is included with the shipment. Refer to installation instructions in the kit.

UNLOADING AND ASSEMBLY

STEP 8. INSTALL BATTERIES

The batteries should conform to the following specification:

RATING	BCI GROUP	CCA	VOLT
Heavy Duty, Off-Road, Vibration Resistant	31A or 29H	650 (min)	12

- a. Open engine compartment hood to highest position.

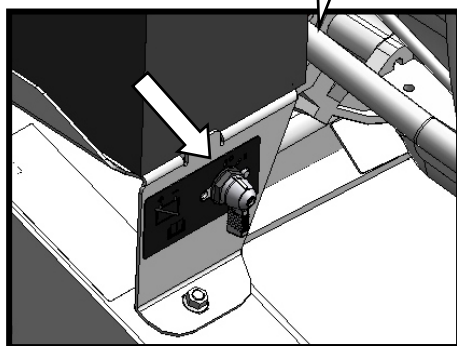
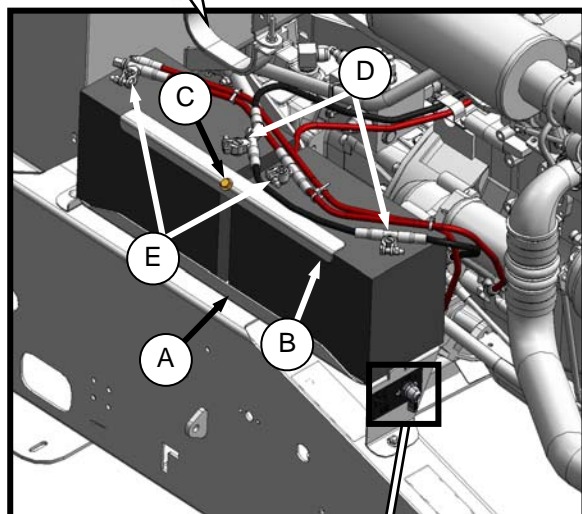

- b. A battery main disconnect switch is located on the battery tray. Ensure switch is switched to POWER OFF.
- c. Locate new batteries on holder (A).
- d. Install strap (B) with bolts (C).

IMPORTANT

BATTERY IS NEGATIVE GROUNDED. Always connect starter cable to the positive (+) terminal of battery, and battery ground cable to negative (-) terminal of battery. Reversed polarity in battery or alternator may result in permanent damage to electrical system.

- e. Attach negative (black) cable clamps (D) to negative post on batteries, and tighten clamps.
- f. Attach positive (red) cable clamps (E) to positive post on batteries, and tighten. Re-install plastic covers onto clamps.
- g. Switch battery switch to ON.
- h. Close engine compartment hood.

UNLOADING AND ASSEMBLY

STEP 9. INSTALL AM/FM RADIO

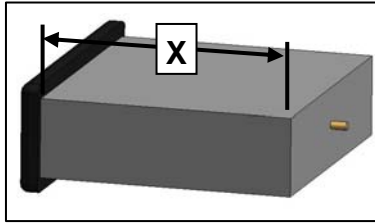

Provision has been made for installation of AM/FM radio. The mounting is designed to fit a DIN E style radio with a depth $X = 161$ mm, and having a 5 mm threaded stud centered on the rear for support. Provision has been made for adjustments should the radio fall outside these parameters.

- a. Ensure the ignition is turned to OFF.

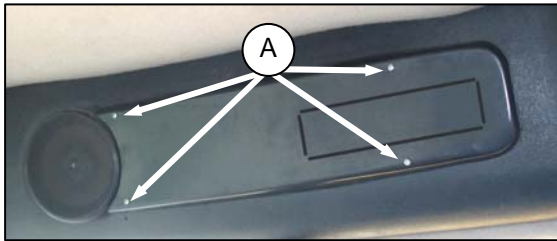

- b. Remove radio panel by removing four screws (A).

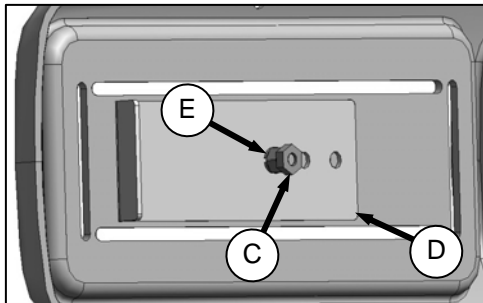

- c. Remove screw and nut (C) to remove support (D) from panel. Retain metric nut (E) and lockwasher.

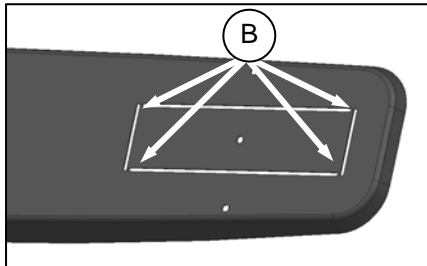

- d. Remove the cut-out by cutting the tabs (B) in the panel. Remove sharp edges on panel.

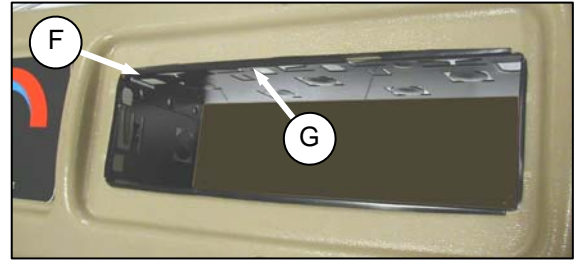

- e. Locate receptacle (F) (supplied with radio) in opening, and secure by bending tabs (G) on receptacle against panel.

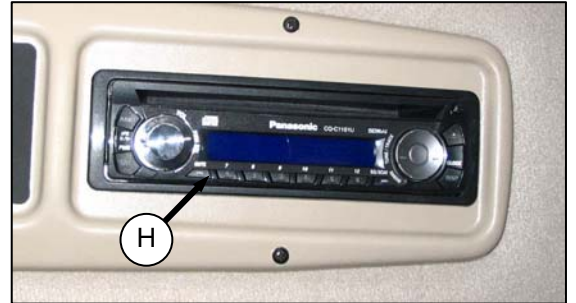

- f. Insert radio into receptacle, and attach radio bezel. Ensure radio locks into position, and faceplate (H) is against the panel.
- g. A six-pin connector for the radio is included in the wiring harness.

In order to mate properly with this connector, the radio must have a six-pin connector (Packard #2977042), and have a terminal arrangement as follows:

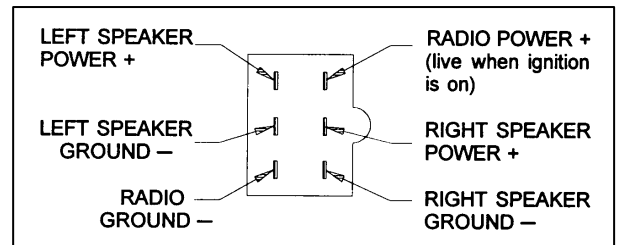

- h. Attach two additional wires in the wiring harness to the radio:
1. **Circuit 503** - Red with 1/4 in. female blade terminal. This is a live wire provided for powering a radio clock/memory, if these exist on your radio.
 2. **Circuit 315** - Black ground wire attaches to radio body.
- i. Plug cable from antenna into radio.

NOTE

An approved radio package is available from Radio Engineering Industries (REI) of Omaha, Nebraska.

(continued next page)

UNLOADING AND ASSEMBLY

j. Attach stud (supplied with radio) to center rear of radio.

k. Attach support (D) to stud on back of radio chassis with lock washer and metric nut (E) that was supplied with the support.

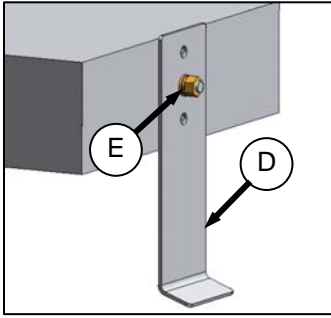

l. Support can be attached to chassis in multiple locations to allow for proper mounting of radio.

m. Re-install radio panel with original screws.

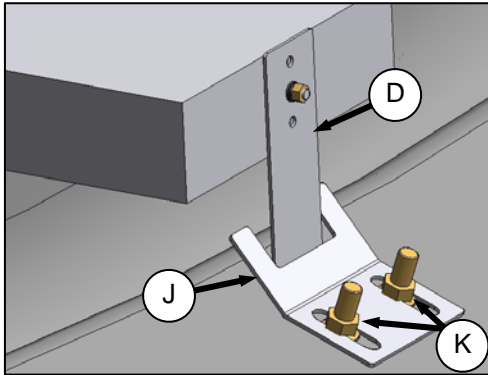

n. Adjust bracket (J) if necessary by loosening nuts (K) to allow radio to slide into opening, and securely capture support (D).

o. Turn battery disconnect switch to ON.

p. Turn ignition key to ACC, switch radio ON, and check operation in accordance with instructions supplied with the radio.

UNLOADING AND ASSEMBLY

STEP 10. ATTACH HEADER

A. HEADER ATTACHMENT - D SERIES



IMPORTANT

A light header float kit may need to be installed, depending on the header size and configuration.

I. CONFIGURE HYDRAULICS

The M105 windrower must be fitted with a draper drive basic kit to operate the D-Series draper headers.

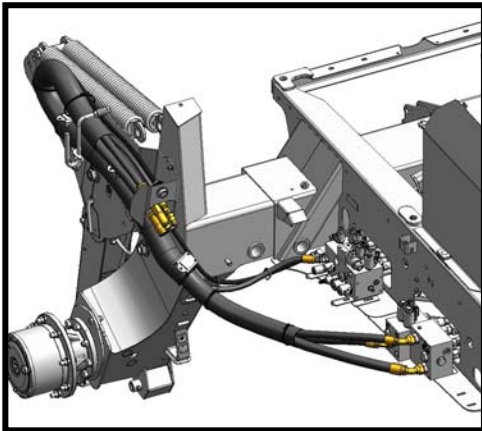

DRAPER HEADER DRIVE HYDRAULICS

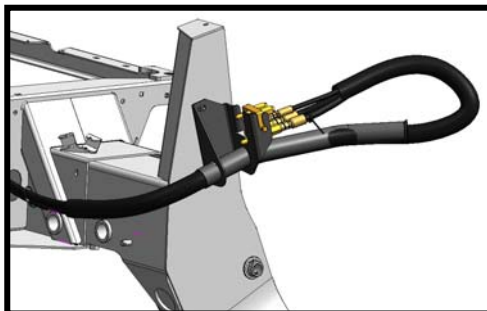
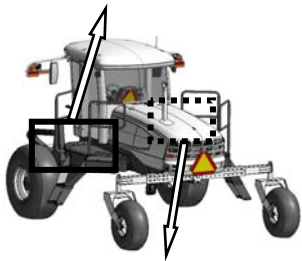

DRAPER HEADER REEL HYDRAULICS

Windrowers equipped with D-Series hydraulics have four header drive hoses on the LH side, and up to five reel drive hoses on the RH side.

If necessary, obtain Kit B5577 from your MacDon Dealer, and install it in accordance with the instructions supplied with the kit

II. ATTACH HEADER BOOTS

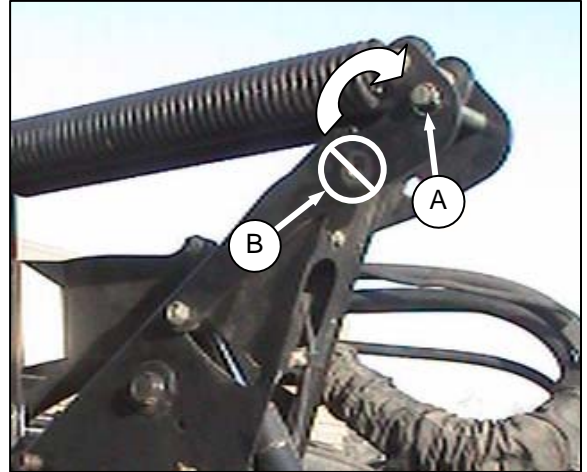

IMPORTANT

To prevent damage to the lift system when lowering header lift linkages without a header or weight box attached to windrower, ensure that float engagement pin is installed in storage location (A), and not installed at hole location (B).

If not installed, attach draper header boots (supplied with header) to windrower lift linkage as follows:

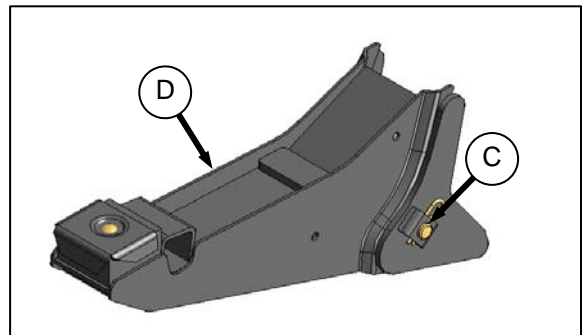

- a. Remove pin (C) from boot (D).

(continued next page)

UNLOADING AND ASSEMBLY

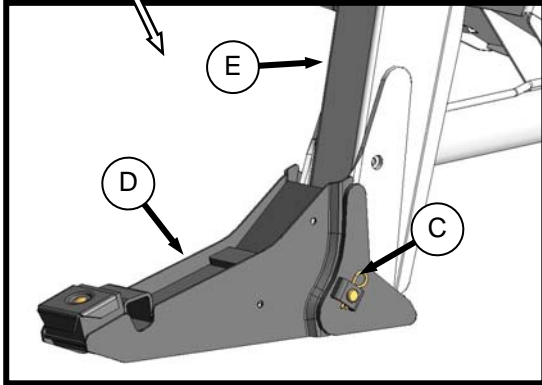

- b. Locate boot (D) on lift linkage (E), and re-install pin (C). Pin may be installed from either side of boot.
- c. Secure pin (C) with hairpin.
- d. Repeat for opposite side.

III. HEADER ATTACHMENT

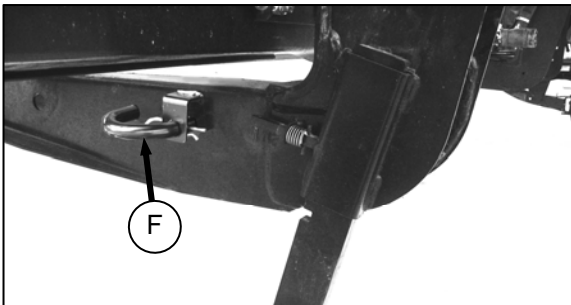

- a. Remove hairpin on pins (F), and remove pins from header legs.

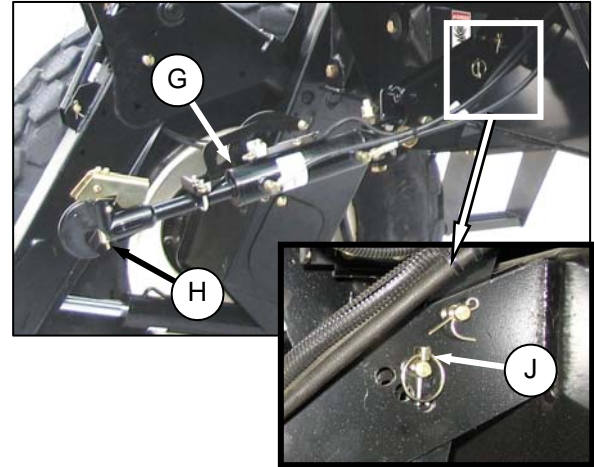
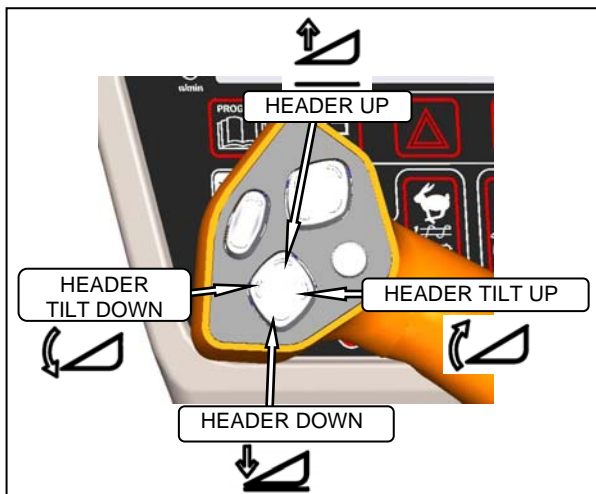

- b. If necessary, re-locate the pin (J) at the frame linkage as required to raise the center-link (G) so that the hook (H) is above the attachment pin on the header.



CAUTION

Check to be sure all bystanders have cleared the area.

- c. Start engine, and activate HEADER DOWN button on the GSL to fully retract header lift cylinders.

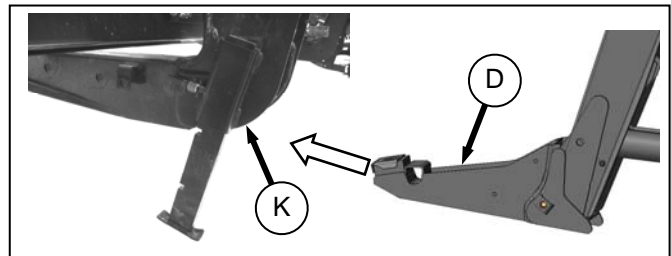

- d. Slowly drive windrower forward so that boots (D) enter header legs (K). Continue to drive slowly forward until lift linkages contact support plates in the header legs, and header nudges forward.
- e. Ensure that lift linkages are properly engaged in header legs, contacting support plates.

(continued next page)

UNLOADING AND ASSEMBLY

f. Connect center-link:

HYDRAULIC LINK

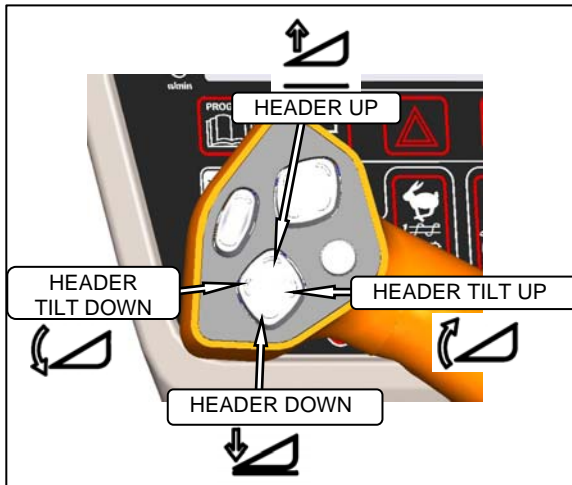

1. Activate HEADER TILT cylinder switches on GSL to extend or retract center-link cylinder (G) so that the hook lines-up with the header attachment pin.



WARNING

Stop windrower engine, and remove key before making adjustments to machine. A child or even a pet could engage the drive.

2. Stop engine, and remove key from ignition.

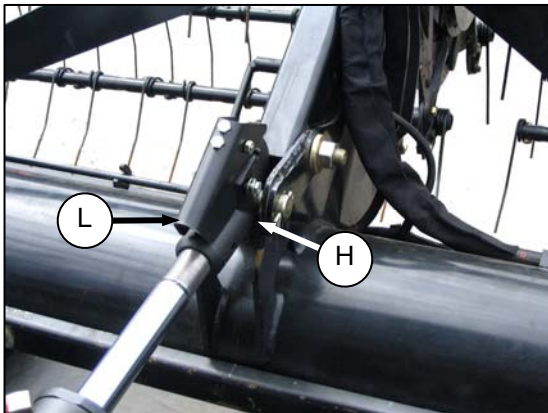

3. Push down on rod end of link cylinder until hook (H) engages pin on header, and is locked.

IMPORTANT

Hook release (L) must be down to enable self-locking mechanism. If the release is open ("up"), manually push it down after hook engages header pin.

4. Check that center-link is locked onto header by pulling upward on rod end of cylinder.
5. Proceed to step g. in next column.

MECHANICAL LINK



WARNING

Stop windrower engine, and remove key before making adjustments to machine. A child or even a pet could engage the drive.

1. Stop engine, and remove key from ignition.

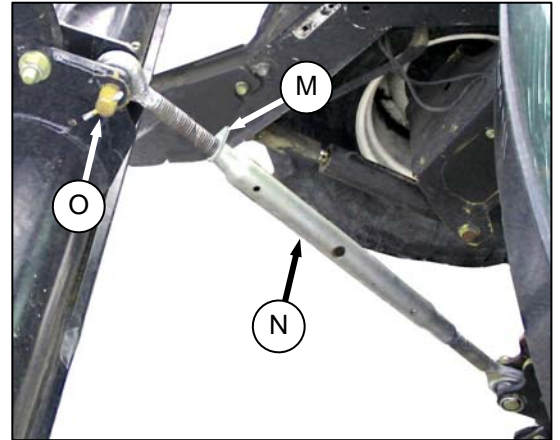

2. Loosen nut (M), and rotate barrel (N) to adjust length so that the link lines-up with header bracket.
3. Install pin (O), and secure with cotter pin.
4. Adjust link to required length for proper header angle by rotating barrel (N). Tighten nut (M) against barrel. A slight tap with a hammer is sufficient.



CAUTION

Check to be sure all bystanders have cleared the area.

- g. Start engine, and press HEADER UP switch to raise header to maximum height.

NOTE

If one end of the header does not raise fully, the lift cylinders require re-phasing. Proceed as follows:

1. Press and hold the HEADER UP switch until both cylinders stop moving.
2. Continue to hold the switch for three to four seconds.
3. Cylinders are phased.

(continued next page)

UNLOADING AND ASSEMBLY



DANGER

To avoid bodily injury from fall of raised header, always engage header lift cylinder stops when working on or around raised header, and before going under header for any reason.

- h. Cylinder stops are located on both header lift cylinders on the windrower. Engage lift cylinder stops on both lift cylinders as follows:
1. Stop engine, and remove key from ignition.

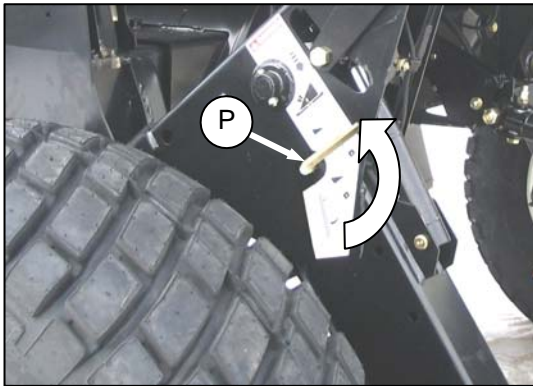

2. Pull lever (P), and rotate toward header to release and lower cylinder stop (Q) onto cylinder.
3. Repeat for opposite lift cylinder.

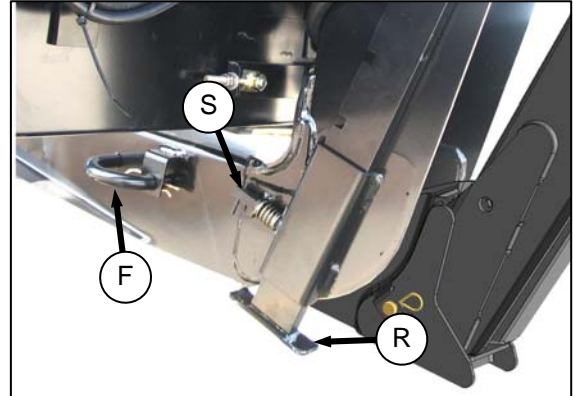

- i. Install pin (F) through header leg, (engaging U-bracket in lift linkage) on both sides, and secure with hairpin.
- j. Raise header stand (R) by pulling pin (S), and lifting stand into "uppermost" position. Release pin (S).

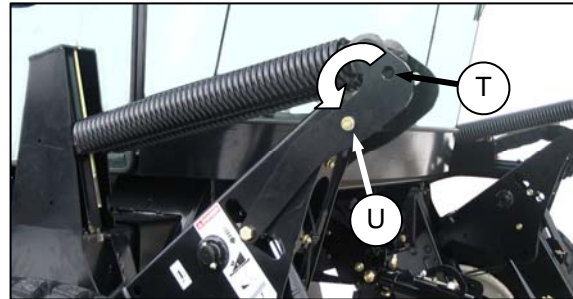

- k. Remove pin from storage location (T) in linkage, and insert in hole (U) to engage float springs. Secure with hairpin.

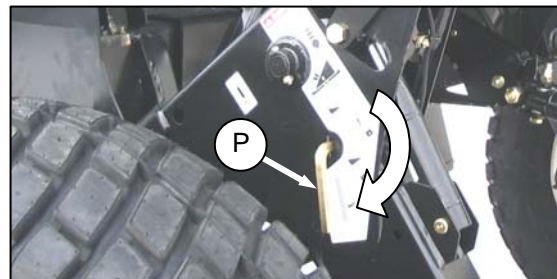

- l. Disengage lift cylinder stop by turning lever (P) downward to release and lower stop until lever locks into vertical position.
- m. Repeat for opposite lift cylinder stop.

(continued next page)

UNLOADING AND ASSEMBLY



CAUTION

Check to be sure all bystanders have cleared the area.

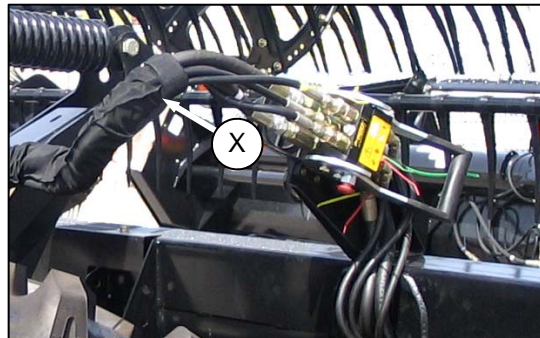
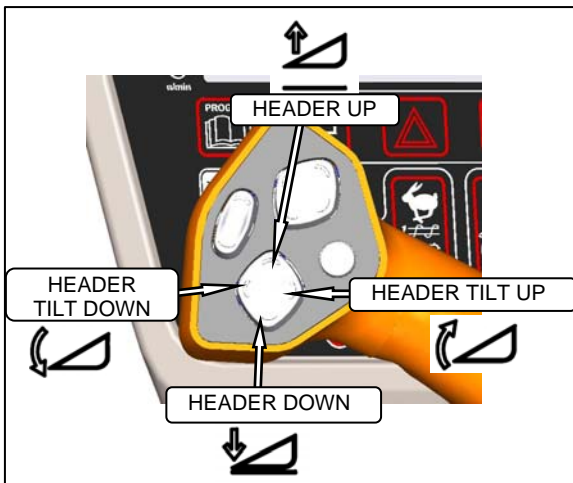

- p. Connect reel hydraulics (X) at RH side of windrower. Refer to the Draper Header Operator's Manual.

- n. Start engine, and activate HEADER DOWN switch on GSL to lower header fully. Stop engine, and remove key.



WARNING

Stop windrower engine, and remove key before making adjustments to machine. A child or even a pet could engage the drive.



- o. Connect header drive hoses (V) and electrical harness (W) to header. Refer to the Draper Header Operator's Manual.

UNLOADING AND ASSEMBLY

B. HEADER ATTACHMENT - A SERIES

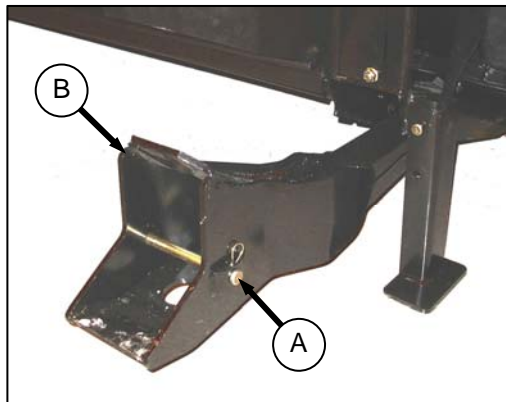

- a. Remove hairpin from pin (A), and remove pin from left and right header boots (B) on header.

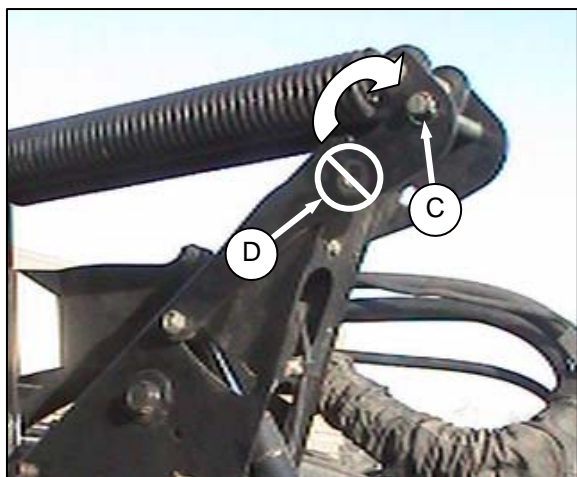

IMPORTANT

To prevent damage to the lift system when lowering header lift linkages without a header or weight box attached to windrower, ensure that float engagement pin is installed in storage location (C), and not installed at hole location (D).

IMPORTANT

For machines equipped with the hydraulic center-link, it may contact the header as the windrower approaches the header for hook-up.

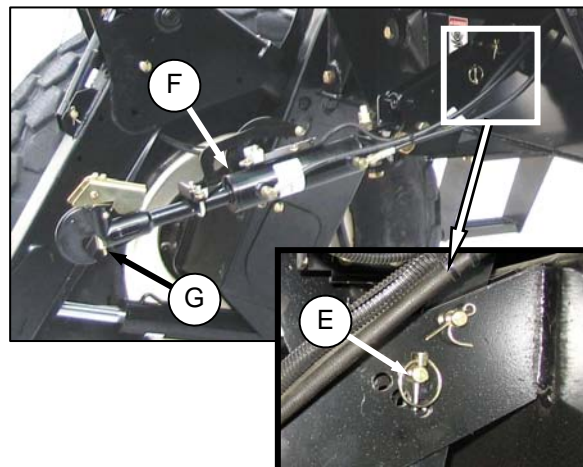

- b. If necessary, re-locate the pin (E) at the frame linkage as required to raise the center-link (F) so that the hook (G) is above the attachment pin on the header.



CAUTION

Check to be sure all bystanders have cleared the area.

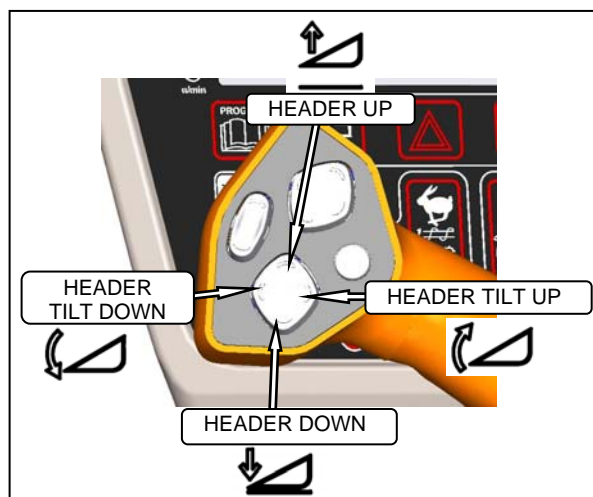

- c. Start the engine, and activate HEADER DOWN button on the GSL to fully retract header lift cylinders.

(continued next page)

UNLOADING AND ASSEMBLY

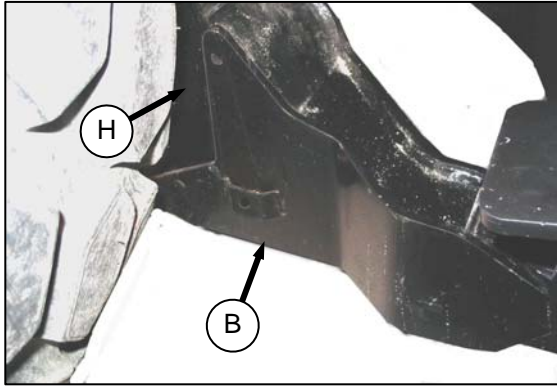

- d. Slowly drive windrower forward so that feet (H) on windrower enter boots (B) on the header. Continue to drive slowly forward until feet engage the boots, and header nudges forward.
- e. Connect center-link as follows:

HYDRAULIC LINK

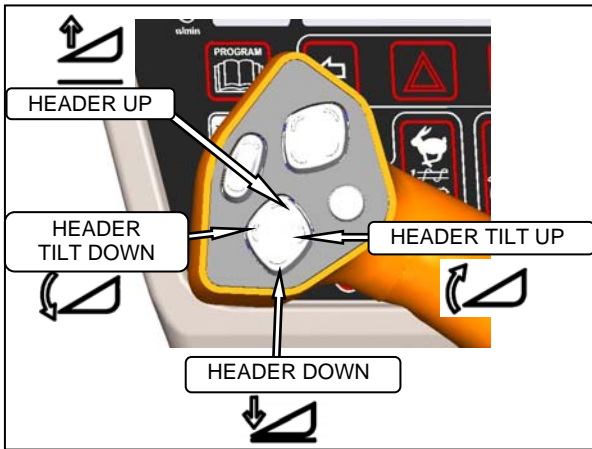

1. Activate HEADER TILT cylinder switches on GSL to extend or retract center-link cylinder so that the hook lines-up with the header attachment pin.
2. Stop engine, and remove key from ignition.

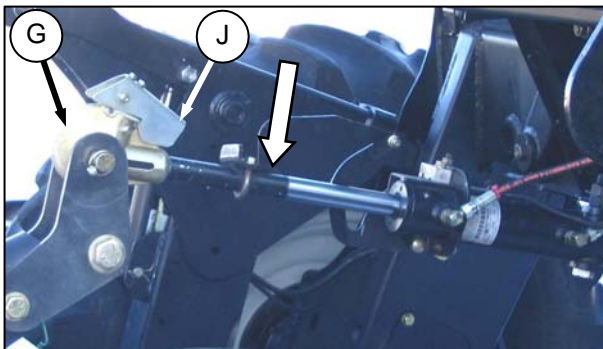

3. Push down on rod end of link cylinder until hook (G) engages pin on header, and is locked.

IMPORTANT

Hook release (J) must be down to enable self-locking mechanism. If the release is open ("up"), manually push it down after hook engages header pin.

4. Check that center-link is locked onto header by pulling upward on rod end of cylinder.
5. Proceed to step f. below.

MECHANICAL LINK



WARNING

Stop windrower engine, and remove key before making adjustments to machine. A child or even a pet could engage the drive.

1. Stop engine and remove key from ignition.

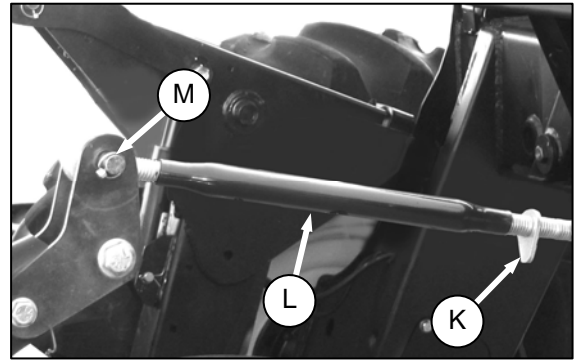

2. Loosen nut (K), and rotate barrel (L), to adjust length so that other end lines-up with header bracket.
3. Install pin (M), and secure with cotter pins.
4. Adjust link to required length for proper header angle by rotating barrel (L). Tighten nut (K) against barrel. A slight tap with a hammer is sufficient.



CAUTION

Check to be sure all bystanders have cleared the area.

- f. Start engine, and press HEADER UP switch to raise header to maximum height.

(continued next page)

UNLOADING AND ASSEMBLY

NOTE

If one end of the header does *not* raise fully, the lift cylinders require re-phasing, proceed as follows:

1. Press and hold the HEADER UP switch until both cylinders stop moving.
2. Continue to hold the switch for three to four seconds.
3. Cylinders are phased.



DANGER

To avoid bodily injury from fall of raised header, always engage header lift cylinder stops when working on or around raised header, and before going under header for any reason.

- g. Cylinder stops are located on both header lift cylinders on the windrower. Engage lift cylinder stops on both lift cylinders as follows:
1. Stop engine, and remove key from ignition.

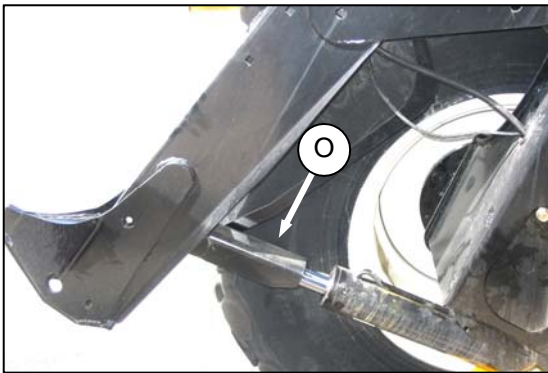
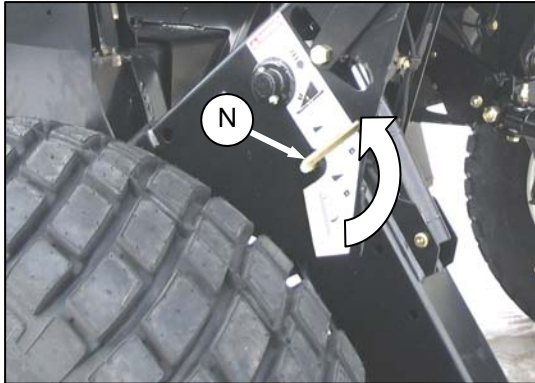

2. Pull lever (N), and rotate toward header to release and lower cylinder stop (O) onto cylinder.
3. Repeat for opposite lift cylinder.

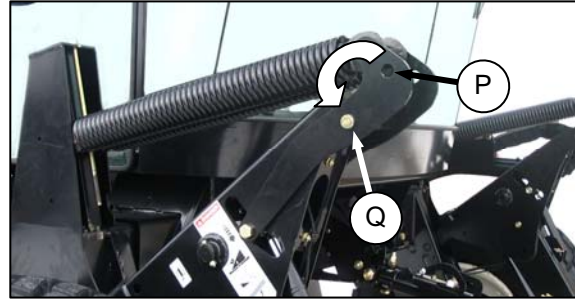

- h. Remove pin from storage location (P) in linkage, and insert in hole (Q) to engage float springs. Secure with lynch pin.
- i. Disengage lift cylinder stop by moving lever (N) downward to release, and lower stop until lever locks into "vertical" position. Repeat for opposite cylinder stop.

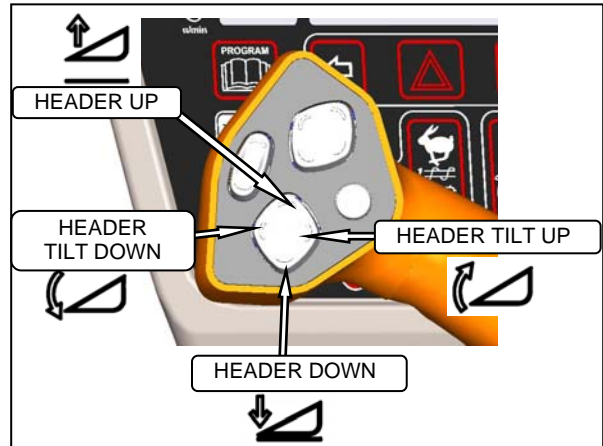

- j. Start engine, and activate HEADER DOWN switch on GSL to lower header fully. Stop engine, and remove key.



- k. Connect header drive hydraulics (R) and electrical harness (S) to header. Refer to your Auger Header Operator's Manual.

UNLOADING AND ASSEMBLY

STEP 11. LUBRICATE MACHINE

Recommended Lubricant

SPEC	DESCRIPTION	USE
SAE Multi- Purpose	High Temperature Extreme Pressure (EP2) Performance With 1% Max Molybdenum Disulphide (NLGI Grade 2) Lithium Base	As Required Unless Otherwise Specified



DANGER

Stop engine, and remove key from ignition before leaving Operator's seat for any reason. A child or even a pet could engage an idling machine.



- a. Wipe grease fitting with a clean cloth before greasing, to avoid injecting dirt and grit.
- b. Inject grease through fitting with grease gun until grease overflows fitting (except where noted).
- c. Leave excess grease on fitting to keep out dirt.
- d. Replace any loose or broken fittings immediately.
- e. If fitting will not take grease, remove and clean thoroughly. Also clean lubricant passageway. Replace fitting if necessary.
- f. Refer to the following illustrations to identify the various locations requiring lubrication.

(continued next page)

UNLOADING AND ASSEMBLY

Lubrication Points

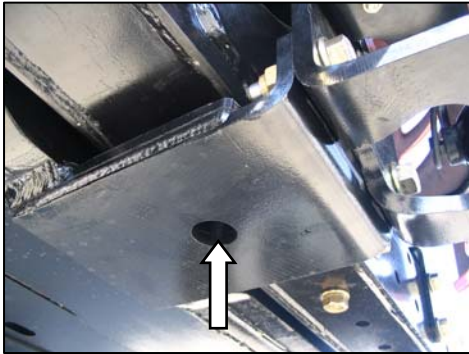
High Temperature Extreme Pressure (EP2) Performance With 1% Max Molybdenum Disulphide (NLGI Grade 2). Lithium Base



WALKING BEAM PIVOT



CASTER PIVOT (BOTH SIDES)



FORMED CASTER WHEEL BEARING 1 PLACE (BOTH WHEELS)

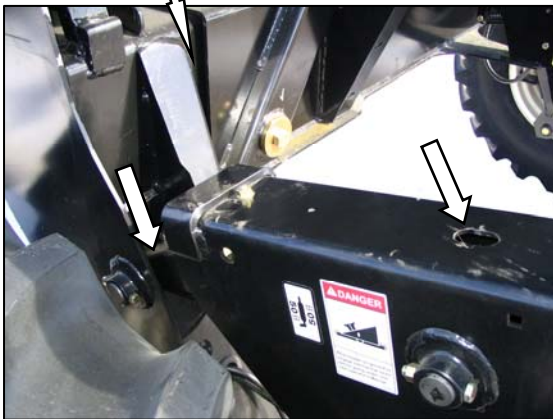

TOP LINK - TWO FITTINGS (BOTH SIDES)



FORKED CASTER SPINDLE BEARINGS TWO PLACES (BOTH WHEELS)

UNLOADING AND ASSEMBLY

STEP 12. PROGRAM CDM

The monitoring system requires programming for each header, and the **header must be attached to the windrower**.

Programming the system may be accomplished with or without the engine running.





- **If engine is running**, the transmission must be in NEUTRAL.
- **If engine is not running**, the ignition must be ON.

Exit Programming Mode at any time by pressing PROGRAM switch, or by turning the ignition OFF.

The system only needs to be programmed once for each header. The Operator may make changes later on to a particular setting to suit windrowing conditions or modifications to the machine.

Most functions have been pre-programmed at the factory, but can be changed by the Operator if required.

Proceed as follows to program the CDM:

- Turn ignition key to RUN, or start the engine. See STEP 13J. III. START ENGINE on page 41.
- Press PROGRAM and SELECT on CDM to enter Programming Mode.
- Press SELECT. TRACTOR SETUP? is displayed on upper line.
- Press  and then SELECT.
- HEADER TYPE? is displayed. DRAPER is flashing on lower line.
- Press  or  to change value on lower line.
- Press SELECT.
- TILT CYL INSTALLED? is displayed.
- Press  or  to change value on lower line.
- Press SELECT to advance to the next L1 item and press arrow keys to change values.
- Press PROGRAM to exit Programming Mode when finished entering desired values.

Refer to Detailed Programming Instructions on following pages.

NOTE

Contact the manufacturer for information regarding software updates to the electronic modules.

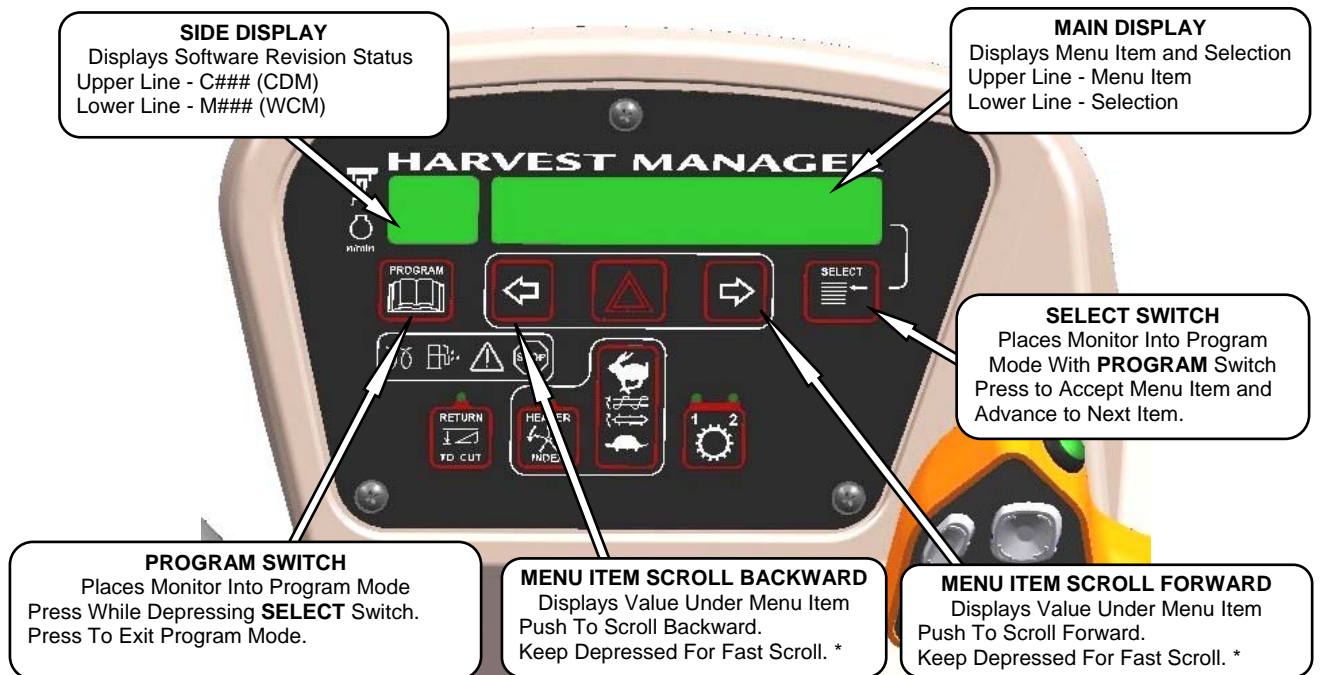

* Fast scroll applies only when changing OVERLOAD SPEED (with expansion module), and TIRE SIZE.

UNLOADING AND ASSEMBLY

DETAILED PROGRAMMING INSTRUCTIONS

(Key ON / Engine Running or Not / Header Disengaged).
 (Press **PROGRAM** and **SELECT** on CDM to enter Programming Mode).

NOTE: ENGINE MUST BE RUNNING TO CALIBRATE SENSORS.

Programming Menu Flow Chart

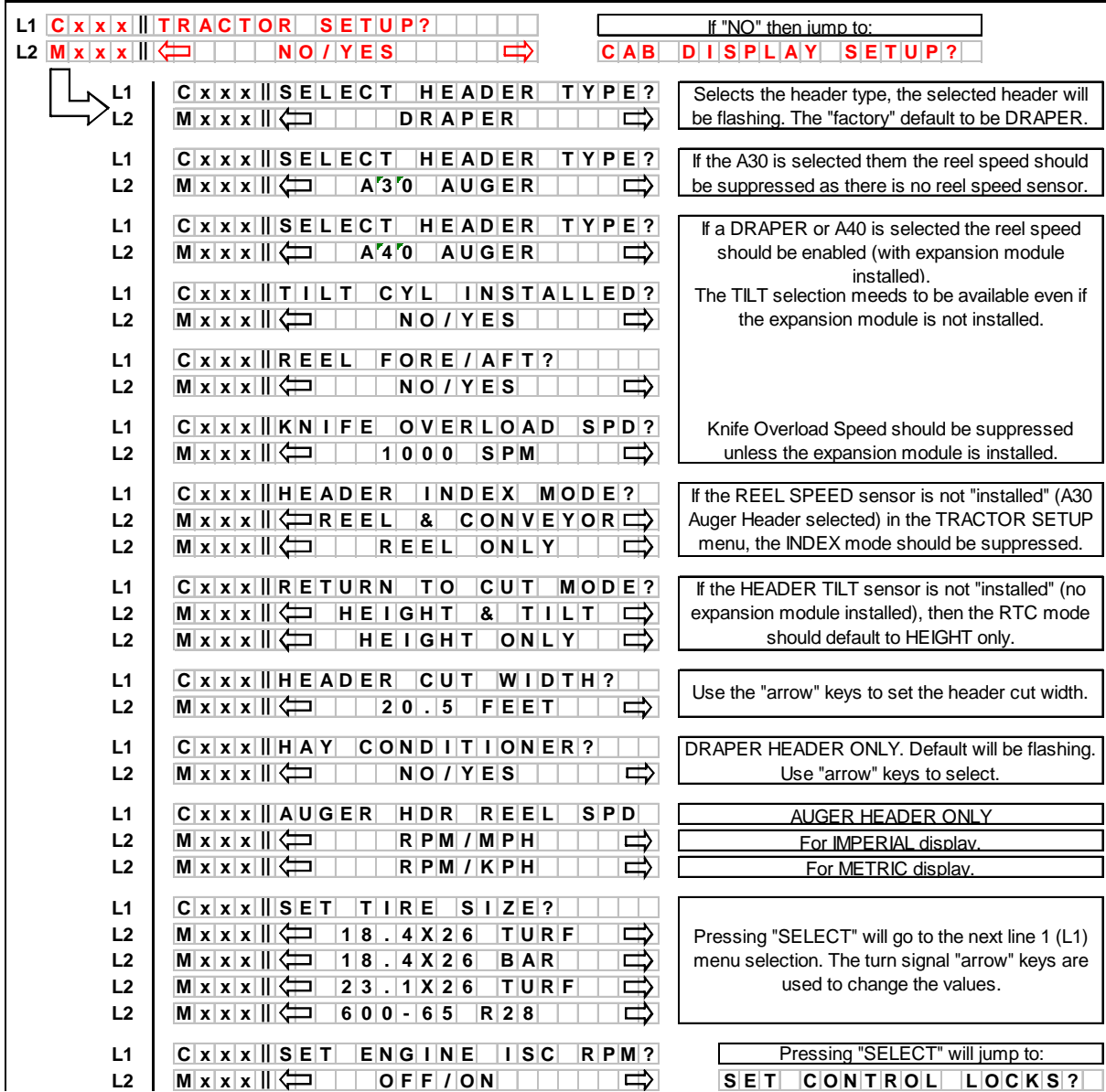

(continued next page)

UNLOADING AND ASSEMBLY

L1 C x x x || SET CONTROL LOCKS? If "NO" then jump to:
 L2 M x x x || ← NO / YES → VIEW CONTROL LOCKS?

↙ L1 C x x x || DRAPER SPEED
 L2 M x x x || ← ENABLED / LOCKED →

L1 C x x x || AUGER SPEED
 L2 M x x x || ← ENABLED / LOCKED →

L1 C x x x || REEL SPEED
 L2 M x x x || ← ENABLED / LOCKED →

L1 C x x x || REEL FORE / AFT
 L2 M x x x || ← ENABLED / LOCKED →

L1 C x x x || HEADER TILT
 L2 M x x x || ← ENABLED / LOCKED →

L1 C x x x || EXIT CONTROL LOCKS?
 L2 M x x x || ← NO / YES →

This menu allows the operator to selectably "lock out" the control functions for the various header functions. The default or selected "status" for each item will flash.

If the expansion module is not installed the corresponding menu items should be suppressed.

The "arrow" keys are used to ENABLE or LOCK OUT each function. Pressing "SELECT" will go to the next L1 menu item.

Tilt to be suppressed if not "installed" in the tractor setup menu.

If "NO" then jump to:
 DRAPER SPEED
 ← ENABLED / LOCKED →

L1 C x x x || VIEW CONTROL LOCKS? If "NO" then jump to:
 L2 M x x x || ← NO / YES → EXIT TRACTOR SETUP?

↙ L1 C x x x || DRAPER SPEED
 L2 M x x x || 5 7 5 . 1 HRS ENABLED
 L2 M x x x || 6 4 8 . 6 HRS LOCKED

L1 C x x x || AUGER SPEED
 L2 M x x x || 5 7 5 . 1 HRS ENABLED
 L2 M x x x || 6 4 8 . 6 HRS LOCKED

L1 C x x x || REEL SPEED
 L2 M x x x || 5 7 5 . 1 HRS ENABLED
 L2 M x x x || 6 4 8 . 6 HRS LOCKED

L1 C x x x || REEL FORE / AFT
 L2 M x x x || 5 7 5 . 1 HRS ENABLED
 L2 M x x x || 6 4 8 . 6 HRS LOCKED

L1 C x x x || HEADER TILT
 L2 M x x x || 5 7 5 . 1 HRS ENABLED
 L2 M x x x || 6 4 8 . 6 HRS LOCKED

L1 C x x x || EXIT VIEW LOCKOUTS?
 L2 M x x x || ← NO / YES →

When the control lock outs are viewed, the lower display line (L2) will show the engine hours and either ENABLED or LOCKED to indicate the present status along with the engine hours at which time the function was either ENABLED or LOCKED.

Using the "arrow" keys allows the operator to select the various functions. Pressing "SELECT" will go to the EXIT VIEW LOCKOUTS? menu selection.

If any of the HDR ANGLE / KNIFE SPEED or REEL SPEED sensors are not "installed" (no expansion module or A30 Auger header selected), they should be suppressed.

If "NO" then jump to:
 DRAPER SPEED
 ← ENABLED / LOCKED →

L1 C x x x || EXIT TRACTOR SETUP? If "NO" then jump to:
 L2 M x x x || ← NO / YES → TILT CYL INSTALLED?

L1 C x x x || CAB DISPLAY SETUP? If "NO" then jump to:
 L2 M x x x || ← NO / YES → CALIBRATE SENSORS?

↙ L1 C x x x || DISPLAY LANGUAGE?
 L2 M x x x || ← ENGLISH →
 L2 M x x x || ← ESPANOL →
 L2 M x x x || ← RUSSIAN →

L1 C x x x || DISPLAY UNITS?
 L2 M x x x || ← IMPERIAL →
 L2 M x x x || ← METRIC →

Use the "arrow" keys to change the default language. Pressing "SELECT" goes to the next L1 menu selection.

The "arrow" keys are used to select between IMPERIAL or METRIC. The default value will be displayed first.

(continued next page)

UNLOADING AND ASSEMBLY

L1 C x x x || CDM BUZZER VOLUME

L2 M x x x || ← [] [] [] [] [] [] [] [] [] [] →

L1 C x x x || CDM BACKLIGHTING

L2 M x x x || ← [] [] [] [] [] [] [] [] [] [] →

L1 C x x x || CDM CONTRAST

L2 M x x x || ← [] [] [] [] [] [] [] [] [] [] →

L1 C x x x || EXIT DISPLAY SETUP?

L2 M x x x || ← [] [] [] [] [] [] [] [] [] [] →

The "arrow" keys are used to change the CDM buzzer volume, CDM backlighting or the CDM contrast, with the bar graph indicating the relative level for each item. When "SELECT" is pressed the program goes to the EXIT DISPLAY SETUP? menu selection.

If "NO" then jump to:
 DISPLAY LANGUAGE? [] [] [] [] [] [] [] [] [] []

L1 C x x x || CALIBRATE SENSORS?

L2 M x x x || ← [] [] [] [] [] [] [] [] [] [] →

If "NO" then jump to:
 DIAGNOSTIC MODE? [] [] [] [] [] [] [] [] [] []



L1 C x x x || TO CALIBRATE SELECT

L2 M x x x || ← [] [] [] [] [] [] [] [] [] [] →

L2 M x x x || ← [] [] [] [] [] [] [] [] [] [] →

L2 M x x x || ← [] [] [] [] [] [] [] [] [] [] →

L1 C x x x || HEIGHT SENSOR CAL

L2 M x x x || RAISE HDR TO START

L1 C x x x || CALIBRATING HEIGHT

L2 M x x x || RAISE HEADER [] [] HOLD

L2 M x x x || RAISE HEADER [] [] DONE

L1 C x x x || HEIGHT SENSOR CAL

L2 M x x x || PRESS LOWER HEADER

L1 M x x x || CALIBRATING HEIGHT

L2 M x x x || LOWER HEADER [] [] HOLD

L2 M x x x || HT SENSOR [] [] COMPLETE

L1 C x x x || TO CALIBRATE SELECT

L2 M x x x || ← [] [] [] [] [] [] [] [] [] [] →

L1 C x x x || TO CALIBRATE SELECT

L2 M x x x || ← [] [] [] [] [] [] [] [] [] [] →

L2 M x x x || ← [] [] [] [] [] [] [] [] [] [] →

L1 M x x x || HDR TILT SENSOR CAL

L2 M x x x || EXTEND TLT TO START

L1 C x x x || CALIBRATING TILT

L2 M x x x || EXTEND TILT [] [] HOLD

L2 M x x x || EXTEND TILT [] [] DONE

L1 M x x x || HDR TILT SENSOR CAL

L2 M x x x || PRESS RETRACT TILT

L1 C x x x || CALIBRATING TILT

L2 M x x x || RETRACT TILT [] [] HOLD

L2 M x x x || HDR TILT [] [] COMPLETE

L1 C x x x || TO CALIBRATE SELECT

L2 M x x x || ← [] [] [] [] [] [] [] [] [] [] →

L2 M x x x || ← [] [] [] [] [] [] [] [] [] [] →

L1 C x x x || EXIT CALIBRATION?

L2 M x x x || ← [] [] [] [] [] [] [] [] [] [] →

The operator can select any of the two items requiring calibration or to STOP & EXIT the menu.

When a function is activated, the display will indicate the function being calibrated. HOLD will flash until the system has completed reading in the signal with the header fully raised.

DONE will flash and prompt the operator to COMPLETE the sensor calibration by lowering the header.

The menu will display the last item selected when the calibration routine is completed.

If the HEADER TILT option in the TRACTOR SETUP is set to NO then only HEIGHT should be available as a menu selection for calibration.

If "NO" then jump to:
 TO CALIBRATE SELECT

(continued next page)

UNLOADING AND ASSEMBLY

L1	C x x x DIAGNOSTIC MODE?		If "NO" then jump to:																												
L2	M x x x <input type="button" value="←"/> NO / YES <input type="button" value="→"/>		TRACTOR SETUP?																												
<div style="display: flex; align-items: center;"> <div style="margin-right: 10px;"> <input type="button" value="↙"/> </div> <div style="margin-right: 10px;">L1</div> <div style="border: 1px solid black; padding: 2px;">C x x x VIEW ERROR CODES?</div> <div style="margin-left: 10px;">If "NO" then jump to:</div> </div>																															
<div style="display: flex; align-items: center;"> <div style="margin-right: 10px;">L2</div> <div style="border: 1px solid black; padding: 2px;">M x x x <input type="button" value="←"/> NO / YES <input type="button" value="→"/></div> <div style="margin-left: 10px;">ENTER SENSOR SETUP?</div> </div>																															
<div style="display: flex; align-items: center;"> <div style="margin-right: 10px;"> <input type="button" value="↙"/> </div> <div style="margin-right: 10px;">L1</div> <div style="border: 1px solid black; padding: 2px;">C x x x VIEW TRACTOR CODES?</div> <div style="margin-left: 10px;">If "NO" then jump to:</div> </div>																															
<div style="display: flex; align-items: center;"> <div style="margin-right: 10px;">L2</div> <div style="border: 1px solid black; padding: 2px;">M x x x <input type="button" value="←"/> NO / YES <input type="button" value="→"/></div> <div style="margin-left: 10px;">ENTER SENSOR SETUP?</div> </div>																															
<div style="display: flex; align-items: center;"> <div style="margin-right: 10px;">L1</div> <div style="border: 1px solid black; padding: 2px;"> <table style="width: 100%; border-collapse: collapse;"> <tr> <td style="width: 5%; text-align: center;">1</td> <td style="width: 5%; border: 1px solid black;"> </td> <td style="width: 5%; border: 1px solid black;">1</td> <td style="width: 5%; border: 1px solid black;">2</td> <td style="width: 5%; border: 1px solid black;">3</td> <td style="width: 5%; border: 1px solid black;">4</td> <td style="width: 5%; border: 1px solid black;">. 5</td> <td style="width: 5%; border: 1px solid black;">HRS</td> <td style="width: 5%; border: 1px solid black;">1</td> <td style="width: 5%; border: 1px solid black;">2</td> <td style="width: 5%; border: 1px solid black;">3</td> <td style="width: 5%; border: 1px solid black;"> </td> <td style="width: 5%; border: 1px solid black;"><input type="button" value="←"/></td> <td style="width: 5%; border: 1px solid black;"><input type="button" value="→"/></td> </tr> <tr> <td colspan="14" style="border: 1px solid black; padding: 2px;">E 4 7 SENSOR VOLTS LOW</td> </tr> </table> </div> <div style="margin-left: 10px;">The last 10 distinct error codes are stored along with the code #, Exxx, engine hours and number of occurrences. The "arrow" keys are used to cycle between codes.</div> </div>				1		1	2	3	4	. 5	HRS	1	2	3		<input type="button" value="←"/>	<input type="button" value="→"/>	E 4 7 SENSOR VOLTS LOW													
1		1	2	3	4	. 5	HRS	1	2	3		<input type="button" value="←"/>	<input type="button" value="→"/>																		
E 4 7 SENSOR VOLTS LOW																															
<div style="display: flex; align-items: center;"> <div style="margin-right: 10px;">L1</div> <div style="border: 1px solid black; padding: 2px;"> <table style="width: 100%; border-collapse: collapse;"> <tr> <td style="width: 5%; text-align: center;">2</td> <td style="width: 5%; border: 1px solid black;"> </td> <td style="width: 5%; border: 1px solid black;">1</td> <td style="width: 5%; border: 1px solid black;">2</td> <td style="width: 5%; border: 1px solid black;">3</td> <td style="width: 5%; border: 1px solid black;">4</td> <td style="width: 5%; border: 1px solid black;">. 5</td> <td style="width: 5%; border: 1px solid black;">HRS</td> <td style="width: 5%; border: 1px solid black;">1</td> <td style="width: 5%; border: 1px solid black;">2</td> <td style="width: 5%; border: 1px solid black;">3</td> <td style="width: 5%; border: 1px solid black;"> </td> <td style="width: 5%; border: 1px solid black;"><input type="button" value="←"/></td> <td style="width: 5%; border: 1px solid black;"><input type="button" value="→"/></td> </tr> <tr> <td colspan="14" style="border: 1px solid black; padding: 2px;">E 7 1 LOW HYDRAULIC OIL</td> </tr> </table> </div> </div>				2		1	2	3	4	. 5	HRS	1	2	3		<input type="button" value="←"/>	<input type="button" value="→"/>	E 7 1 LOW HYDRAULIC OIL													
2		1	2	3	4	. 5	HRS	1	2	3		<input type="button" value="←"/>	<input type="button" value="→"/>																		
E 7 1 LOW HYDRAULIC OIL																															
<div style="display: flex; align-items: center;"> <div style="margin-right: 10px;">L1</div> <div style="border: 1px solid black; padding: 2px;">C x x x EXIT TRACTOR CODES?</div> <div style="margin-left: 10px;">If "NO" then jump to:</div> </div>																															
<div style="display: flex; align-items: center;"> <div style="margin-right: 10px;">L2</div> <div style="border: 1px solid black; padding: 2px;">M x x x <input type="button" value="←"/> NO / YES <input type="button" value="→"/></div> <div style="margin-left: 10px;">VIEW TRACTOR CODES?</div> </div>																															
<div style="display: flex; align-items: center;"> <div style="margin-right: 10px;">L1</div> <div style="border: 1px solid black; padding: 2px;">C x x x ENTER SENSOR SETUP?</div> <div style="margin-left: 10px;">If "NO" then jump to:</div> </div>																															
<div style="display: flex; align-items: center;"> <div style="margin-right: 10px;">L2</div> <div style="border: 1px solid black; padding: 2px;">M x x x <input type="button" value="←"/> NO / YES <input type="button" value="→"/></div> <div style="margin-left: 10px;">READ SENSOR INPUTS?</div> </div>																															
<div style="display: flex; align-items: center;"> <div style="margin-right: 10px;"> <input type="button" value="↙"/> </div> <div style="margin-right: 10px;">L1</div> <div style="border: 1px solid black; padding: 2px;">C x x x HEADER HT SENSOR</div> <div style="margin-left: 10px;">The operator can select each sensor and selectively enable or disable the sensor in the event of a sensor malfunction.</div> </div>																															
<div style="display: flex; align-items: center;"> <div style="margin-right: 10px;">L2</div> <div style="border: 1px solid black; padding: 2px;">M x x x <input type="button" value="←"/> ENABLE / DISABLE <input type="button" value="→"/></div> <div style="margin-left: 10px;">If no expansion module or an A30 auger header is selected, the corresponding menu items should be suppressed.</div> </div>																															
<div style="display: flex; align-items: center;"> <div style="margin-right: 10px;">L1</div> <div style="border: 1px solid black; padding: 2px;">C x x x HEADER TILT SENSOR</div> <div style="margin-left: 10px;">When "SELECT" is pressed the program goes to the EXIT SENSOR SETUP? selection.</div> </div>																															
<div style="display: flex; align-items: center;"> <div style="margin-right: 10px;">L2</div> <div style="border: 1px solid black; padding: 2px;">M x x x <input type="button" value="←"/> ENABLE / DISABLE <input type="button" value="→"/></div> </div>																															
<div style="display: flex; align-items: center;"> <div style="margin-right: 10px;">L1</div> <div style="border: 1px solid black; padding: 2px;">C x x x KNIFE SPEED SENSOR</div> </div>																															
<div style="display: flex; align-items: center;"> <div style="margin-right: 10px;">L2</div> <div style="border: 1px solid black; padding: 2px;">M x x x <input type="button" value="←"/> ENABLE / DISABLE <input type="button" value="→"/></div> </div>																															
<div style="display: flex; align-items: center;"> <div style="margin-right: 10px;">L1</div> <div style="border: 1px solid black; padding: 2px;">C x x x REEL SPEED SENSOR</div> </div>																															
<div style="display: flex; align-items: center;"> <div style="margin-right: 10px;">L2</div> <div style="border: 1px solid black; padding: 2px;">M x x x <input type="button" value="←"/> ENABLE / DISABLE <input type="button" value="→"/></div> </div>																															
<div style="display: flex; align-items: center;"> <div style="margin-right: 10px;">L1</div> <div style="border: 1px solid black; padding: 2px;">C x x x EXIT SENSOR SETUP?</div> <div style="margin-left: 10px;">If "NO" then jump to:</div> </div>																															
<div style="display: flex; align-items: center;"> <div style="margin-right: 10px;">L2</div> <div style="border: 1px solid black; padding: 2px;">M x x x <input type="button" value="←"/> NO / YES <input type="button" value="→"/></div> <div style="margin-left: 10px;">KNIFE SPEED SENSOR</div> </div>																															
<div style="text-align: center; border: 1px solid black; padding: 2px;">Or to the first sensor "installed"</div>																															

(continued next page)

UNLOADING AND ASSEMBLY

L1 | C x x x || S E N S O R I N P U T | ← | → |
L2 | M x x x || H D R H E I G H T | S E N S O R

L1 | C x x x || S E N S O R I N P U T | ← | → |
L2 | M x x x || H E A D E R A N G L E S E N S O R

L1 | C x x x || S E N S O R I N P U T | ← | → |
L2 | M x x x || K N I F E S P E E D | S E N S O R

L1 | C x x x || S E N S O R I N P U T | ← | → |
L2 | M x x x || R E E L S P E E D | S E N S O R

If a sensor has been disabled "SENSOR" will be flashing in the area where the input reading would have been.

If no expansion module or an A30 auger header is selected, the corresponding menu items should be suppressed.

L1 | C x x x || A C T I V A T E F U N C T I O N S ? | If "NO" then jump to:
L2 | M x x x || ← | | | N O / Y E S | → | | | E X I T D I A G N O S T I C S ? |

↙ L1 | C x x x || A C T I V A T E F U N C T I O N S ?
L2 | M x x x || H E A D E R ← | D O W N / U P | → |

L1 | C x x x || A C T I V A T E F U N C T I O N S ?
L2 | M x x x || R E E L ← | D O W N / U P | → |

For diagnostic purposes each header function can be activated by using the "arrow" keys on the CDM. When "SELECT" is pressed the program will go to the next function that can be activated.

L1 | C x x x || A C T I V A T E F U N C T I O N S ?
L2 | M x x x || H D R T I L T ← | I N / O U T | → |

If the HEADER TILT cylinder or the REEL FORE / AFT valve is not installed under the TRACTOR SETUP menu then the ACTIVATE FUNCTIONS menu selection for these items should be suppressed.

L1 | C x x x || A C T I V A T E F U N C T I O N S ?
L2 | M x x x || K N I F E D R I V E O N | → |

L1 | C x x x || A C T I V A T E F U N C T I O N S ?
L2 | M x x x || D R A P E R / A U G E R O N | → |

L1 | C x x x || A C T I V A T E F U N C T I O N S ?
L2 | M x x x || R E E L ← | F O R E / A F T | → |

L1 | C x x x || A C T I V A T E H Y D P U R G E ?
L2 | M x x x || ← | | | N O / Y E S | → |

ACTIVATE HYD PURGE - This is to allow the operator to purge the air from a new or changed pump system.

L1 | C x x x || T O A C T I V A T E P U R G E | | | |
L2 | M x x x || P R E S S A N D H O L D | | | → |

L1 | C x x x || P U R G E C Y C L E S T A R T E D
L2 | M x x x || P R E S S A N D H O L D | | | → |

Pressing and holding the right hand "arrow" button activates a predetermined timed purge cycle. Releasing pressure on the switch or a completed cycle (timed out) will jump to the PURGE CYCLE ENDED menu selection.

L1 | C x x x || P U R G E C Y C L E E N D E D
L2 | M x x x || | | | | | | | | | | |

L1 | C x x x || P U R G E C Y C L E E N D E D
L2 | M x x x || ← | N O | | | E X I T | | | Y E S | → |

L1 | C x x x || E X I T F U N C T I O N M E N U ?
L2 | M x x x || ← | | | | N O / Y E S | | | → |

If "NO" then jump to:
H E A D E R ← | D O W N / U P | → |

L1 | C x x x || E X I T D I A G N O S T I C S ?
L2 | M x x x || ← | | | | N O / Y E S | | | → |

If "NO" then jump to:
D I A G N O S T I C M O D E ? | | |

PRE-DELIVERY CHECKS

STEP 13. PERFORM PRE-DELIVERY CHECKS



WARNING

Stop windrower engine, and remove key before making adjustments to machine. A child or even a pet could engage the drive.

- Perform the final checks and adjustments as listed on the "Pre-Delivery Checklist" (yellow sheet attached to back of this instruction) to ensure the machine is field-ready. Refer to the following pages for detailed instructions as indicated on the Checklist.
- The completed Checklist should be retained either by the Operator or the Dealer.

A. SERIAL NUMBERS



- Record windrower and engine serial numbers on Checklist.

B. FINAL DRIVE LUBRICANT LEVEL



- Rotate wheel so that one of the plugs is horizontally aligned with the center of the hub.
- Remove the plug. The oil should be visible through the hole, or slightly running out.

C. TIRE PRESSURES

Measure tire pressure with a gauge.

TIRE TYPE	SIZE	PRESSURE
Bar	18.4 - 26	32 psi (221 kPa)
	600 - 65R28	26 psi (179 kPa)
Turf	18.4 - 26	35 psi (241 kPa)
	23.1 - 26	20 psi (138 kPa)
	580 / 70 R26	24 psi (165 kPa)

All Rear Tire Pressures are 10 psi (69 kPa).

D. ENGINE COOLANT

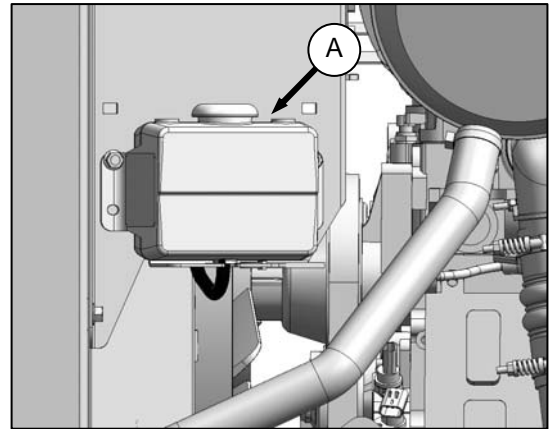

- Check the coolant level in the coolant recovery tank (A). Tank should be at least one-half full.
- Check coolant concentration in the radiator. Coolant shall be good for temperatures of -30°F (-34°C).

PRE-DELIVERY CHECKS

E. AIR CLEANER



- a. Check that air cleaner cap is firmly attached, and that all clamps on air cleaner are secure.

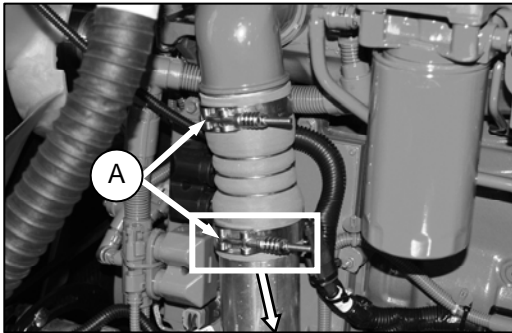
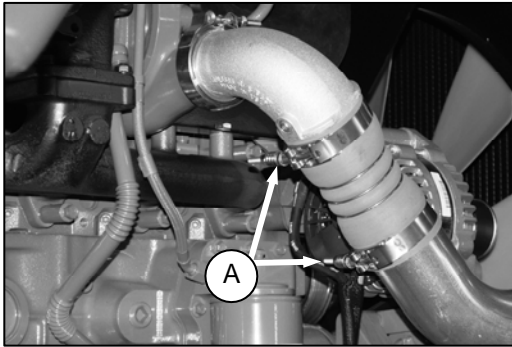

HOLD 0.018 in. (0.46 mm) GAUGE BETWEEN MIDDLE COILS AND TIGHTEN CLAMP UNTIL GAUGE IS SNUG. REMOVE GAUGE.

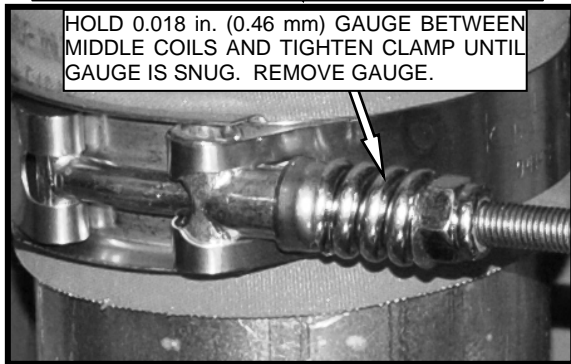

- b. Check spring clamps (A) on charge air cooling duct connections (at turbocharger outlet, engine intake, and inside cooling box).

F. HYDRAULIC OIL LEVEL



- a. Turn filler cap counter clockwise to loosen bung, and remove dipstick.

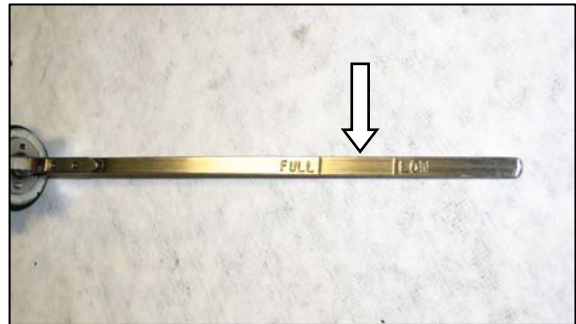

- b. Check that level is between LOW and FULL marks.
- c. Re-install filler cap, and turn clockwise to tighten bung.

G. FUEL SEPARATOR



- a. Turn drain valve by hand 1-1/2 to 2 turns counter clockwise until draining occurs.
- b. Drain the filter sump of water and sediment until clear fuel is visible. Clean as necessary.
- c. Turn the valve clockwise to close the drain.

PRE-DELIVERY CHECKS

H. A/C COMPRESSOR BELT

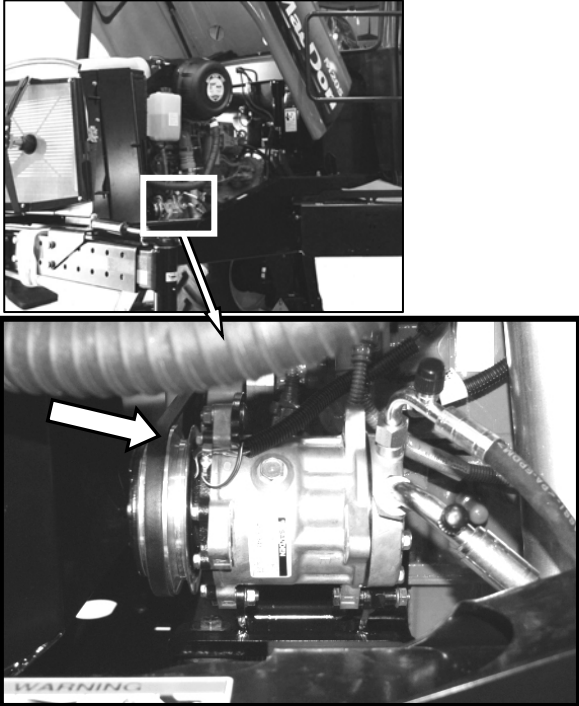

- a. Tension on A/C compressor belt should be such that a force of 8 to 12 lbf (35 - 55 N) deflects the belt 3/16 in. (5 mm) at mid-span.

PRE-DELIVERY CHECKS

I. PERFORM SAFETY SYSTEM CHECKS



CAUTION

Check to be sure all bystanders have cleared the area.

A properly functioning system should operate as follows:

- The starter should engage ONLY when the GSL is in N-DETENT, the steering wheel is locked in the CENTER position, and the HEADER DRIVE switch is OFF.
- Under the above conditions, the brake should engage, and the machine should not move after engine start-up.
- The steering wheel should not lock with the engine running, and GSL out of N-DETENT.
- The machine should not move with the engine running, and with the steering wheel still centered, when the GSL is pulled straight out of N-DETENT (not in forward or reverse).

If the system does not function as described above, refer to the M105 Operator's Manual for adjustment procedures.

- a. With the engine shut down, and the HEADER DRIVE switch engaged:
 1. Try to start the engine. The CDM will display "HEADER ENGAGED" on the upper line, and "DISENGAGE HEADER" on the lower line.
 2. If the engine turns over, the system requires adjustment, refer to the M105 Operator's Manual for adjustment procedures.

- b. With the engine shut down:
 1. Open engine compartment hood.

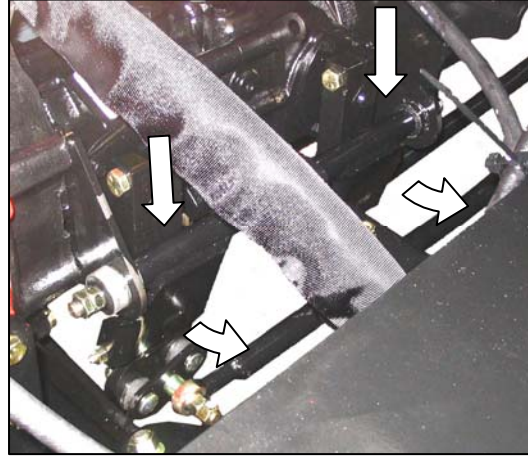

2. Pry the steering interlock away from pintle arms by inserting a wedge or pry bar between one of the interlock channels and pintle arm.
 3. Insert a wood block approximately 3/4 in. (19 mm) thick between the other channel and pintle arm so that the interlock channel is clear of the pintle arm.
 4. Turn the steering wheel off-center, and move the GSL in N-DETENT.
 5. Try to start the engine. The CDM will flash "CENTER STEERING", accompanied by a short beep with each flash, and the engine should not turn over.
 6. If the engine turns over, the system requires adjustment, refer to the M105 Operator's Manual for adjustment procedures.
 7. Remove key.
 8. Remove wood block inserted at step 3. above, and close hood.
- c. With the engine shut down, the steering wheel centered, and the GSL in NEUTRAL (but not in N-DETENT):
 1. Try to start the engine. The CDM will flash "CENTER STEERING" on the upper line, and "PLACE GSL INTO N" on the lower line accompanied by a short beep with each flash, and the engine should not turn over.
 2. If the engine turns over, the system requires adjustment, refer to the M105 Operator's Manual for adjustment procedures.

PRE-DELIVERY CHECKS

J. OPERATIONAL CHECKS

I. ENGINE WARNING LIGHTS



- Turn ignition key (A) to RUN.
- Single loud tone sounds, and engine warning lights (B) illuminate.
- Turn ignition key to OFF.

II. CHECK FUEL LEVEL

- Turn ignition key (A) to RUN.
- Check fuel level by pressing the selector switch (C) on the CDM until FUEL LEVEL is displayed at (D). If required, add sufficient fuel for a 15 minute run.

III. START ENGINE

- Start engine as follows:

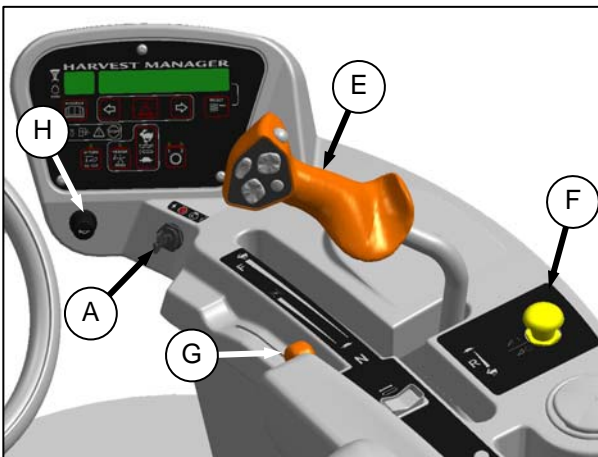

- Move GSL (E) into N-DETENT.
- Turn steering wheel until it locks.
- Push HEADER DRIVE switch (F) to OFF.

- Normal Start: Engine temperature above 60°F (16°C):**

- Set throttle to START position (G) - "fully back".
- Turn ignition key (A) to RUN.
- Single loud tone sounds, engine warning lights illuminate in self-test mode, and CDM displays "HEADER DISENGAGED" and "IN PARK".



CAUTION

Check to be sure all bystanders have cleared the area.

- Sound horn three times with horn button (H).
- Turn ignition key (A) to START until engine starts, and then release key.

IMPORTANT

Do not operate starter for longer than 15 seconds at a time. If engine does not start, wait at least two minutes before trying again. After the third 15 second crank attempt, allow starter to cool for 10 minutes before further cranking attempts.

If engine still does not start, refer to the following table:

PROBLEM	SOLUTION
Controls not in NEUTRAL.	Move GSL to NEUTRAL. Move steering wheel to locked position. Disengage header clutch.
Neutral interlock misadjusted.	Refer to M105 Operator's Manual.
No fuel to engine.	Fill empty fuel tank. Replace clogged filter.
Old fuel in tank.	Drain tank, refill with fresh fuel.
Water, dirt or air in fuel system.	Drain, flush, fill and prime system.
Improper type of fuel.	Use proper fuel for operating conditions.
Crankcase oil too heavy.	Use recommended oil.
Low battery output.	Have battery tested. Check battery electrolyte level.
Poor battery connection.	Clean and tighten loose connections.
Faulty starter.	Refer to M105 Engine Manual.
Wiring shorted, circuit breaker open.	Check continuity of wiring and breaker (manual reset).
Faulty injectors.	Refer to M105 Engine Manual.

(continued next page)

PRE-DELIVERY CHECKS

- c. **Cold Start: Engine temperature 20°F (-7°C) or lower.**

NOTE

Grid heater will not operate if engine temperature is 20°F (-6°C) or higher.

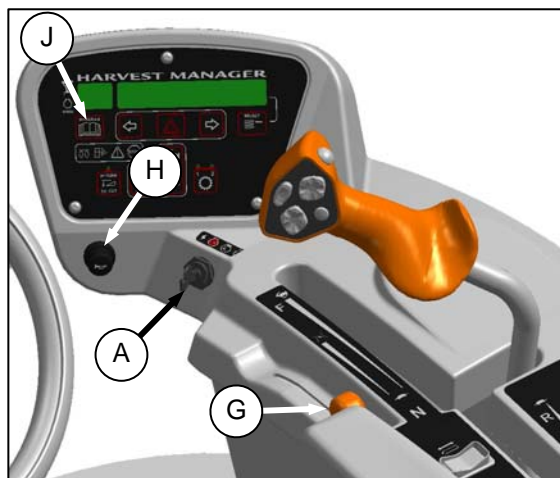

1. Set throttle (G) to START position - "fully back" (low idle).
2. Turn ignition key (A) to RUN.
3. Single loud tone sounds, engine warning lights illuminate, and CDM displays "HEADER DISENGAGED" and "IN PARK".
4. Grid heater light (J) on CDM will cycle ON / OFF / ON after 2 seconds for a pre-set length of time. The operating period for the grid heater and light will change depending engine temperature.
5. When grid heater light goes out, sound horn (H), turn key to START, and crank engine until it starts. Leave throttle at IDLE.

IMPORTANT

If engine fails to start within 15 seconds, cease cranking, and wait two minutes to allow the starting motor to cool before attempting to re-start the engine.

6. If engine fails to start, repeat steps 2 to 5.
7. After start-up, the engine will cycle through a period where it appears to labor.

IMPORTANT

Do not operate engine above 1500 rpm until engine temperature gauge is above 100°F (38°C).

NOTE

Throttle is non-responsive during this time as engine is in "warm up" mode. This mode lasts from 30 seconds to 3 minutes depending on temperature. After engine is stabilized and idling normally, the throttle becomes active.

IV. CDM DISPLAY



Check CDM display (D) is working by pushing SELECT (C) on CDM or SELECT button (K) on GSL.

V. ENGINE SPEED

Check engine rpm on CDM at (L).

IDLE RPM	MAX RPM (No Load)
1100	2270 - 2330

VI. ALTERNATOR CHARGE RATE

Push SELECT switch (C) on CDM until VOLTS displays at (D).

Reading should be 13.8 - 15.0 VOLTS.

PRE-DELIVERY CHECKS

VII. OPERATOR'S PRESENCE SYSTEM CHECKS

- a. With the windrower engine running, place the GSL in NEUTRAL, and turn the steering wheel until it locks.



CAUTION

Check to be sure all bystanders have cleared the area.

- b. With everyone clear of the machine, engage HEADER DRIVE switch.
 1. After header drives are running, stand up out of the seat. In approximately 5 seconds, the header should shut off. If not, the Operator Presence System requires adjustment, refer to the M105 Operator's Manual for adjustment procedures.

NOTE

To re-start the header, move the HEADER DRIVE switch to the OFF, and then to ON.

- c. With the windrower moving at less than 3 mph;
 1. Stand up out of the seat.
 2. The CDM will flash "NO OPERATOR" on the upper line, and "ENGINE SHUTDOWN 5...4...3...2...1...0" on the lower line accompanied by a steady tone. At "0", the engine shuts down.
 3. If the engine does not shut down, the Operator Presence System requires adjustment, refer to the M105 Operator's Manual for adjustment procedures.
- d. With the windrower moving at more than 3 mph;
 1. Stand up out of the seat.
 2. The CDM beeps once, and displays "NO OPERATOR" on the lower line.
 3. If not, the Operator Presence System requires adjustment, refer to the M105 Operator's Manual for adjustment procedures.

VIII. EXTERIOR LIGHTS

- a. Switch FIELD lights ON, and check that all lights as shown are functioning.

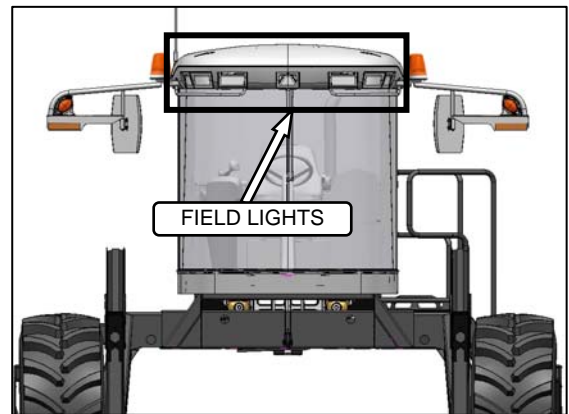

FRONT

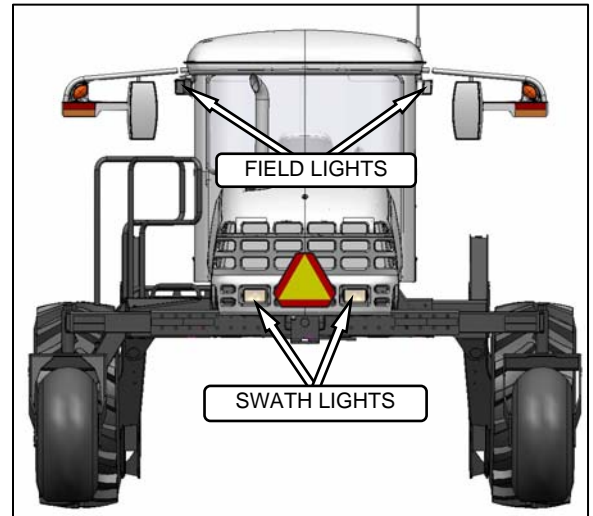

REAR

- b. Turn lights OFF.

(continued next page)

PRE-DELIVERY CHECKS

- c. Switch ROAD lights ON, and check that all lights shown are functioning.

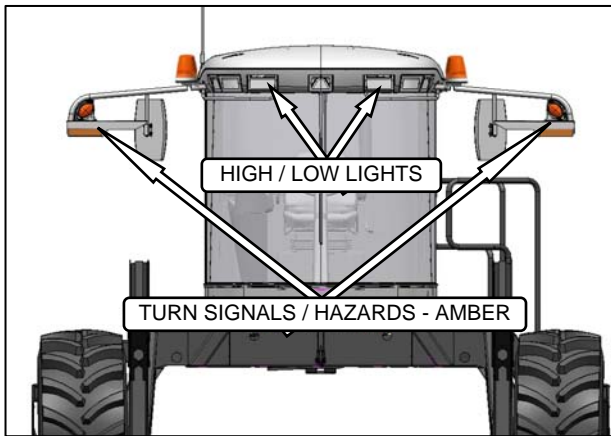
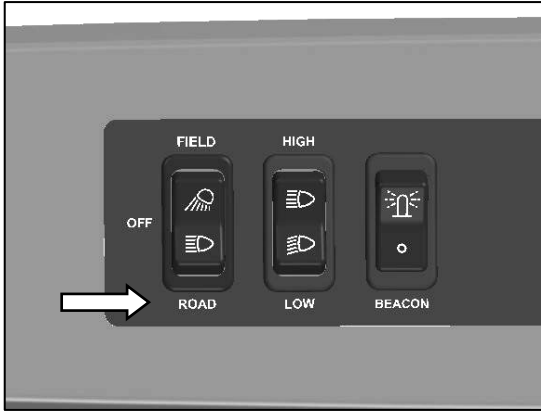

FRONT

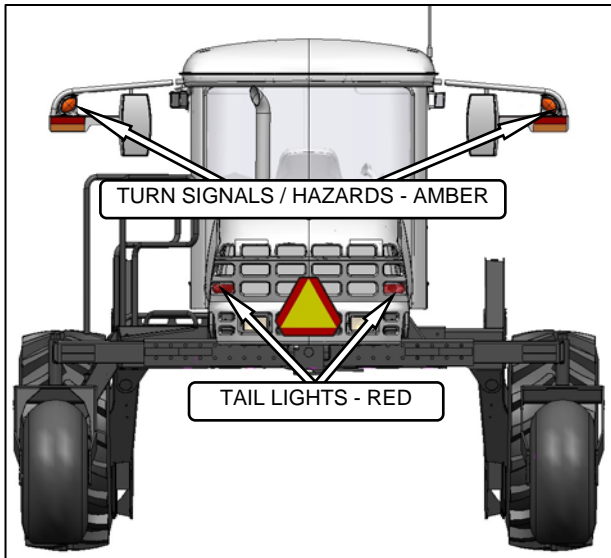

REAR

- d. Activate HIGH / LOW switch.
e. Activate turn signals and hazard warning lights with switches on CDM.

- f. Switch BEACONS ON (if installed), and check that they are functioning. The ignition switch must be at RUN, but the engine does not need to be running.

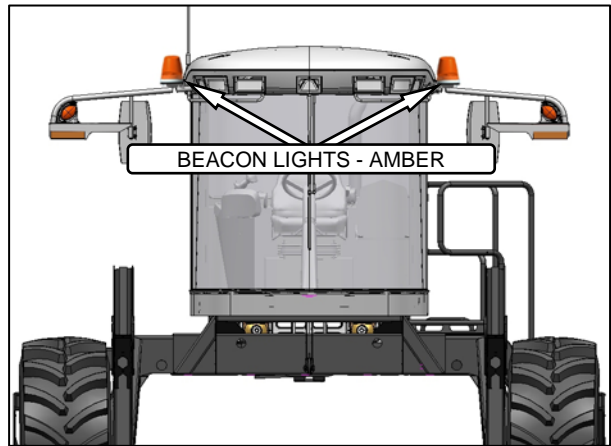

FRONT

IX. INTERIOR LIGHTS

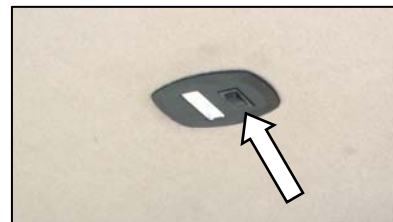

- a. Switch lights ON and OFF with switches on each light. Interior lights only work with road or field light switch ON.

PRE-DELIVERY CHECKS

X. A/C AND HEATER

IMPORTANT

To distribute the oil throughout the system, perform the following steps whenever the machine is first started after storage for more than one week.

- a. Ensure heater shut-off valve at engine is OPEN.

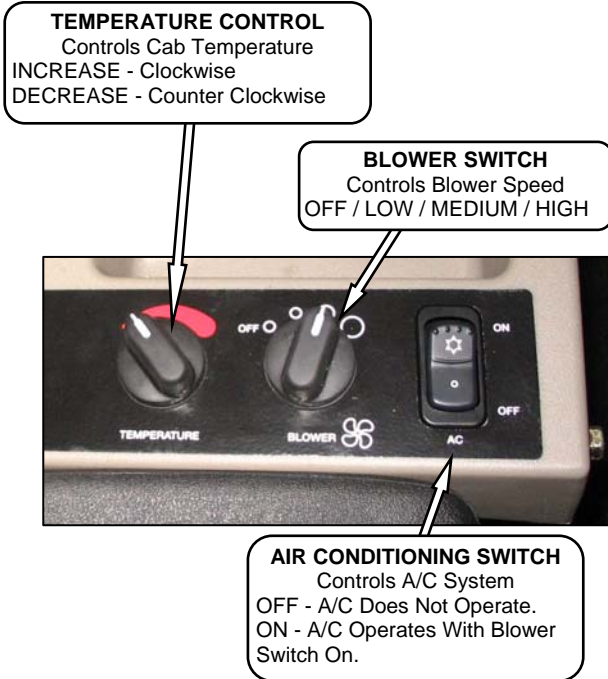

- b. With the engine running, turn blower switch to the "first position", turn temperature control switch to MAXIMUM heating, and A/C control to OFF.
- c. Click A/C switch from OFF to ON for one second, then back to OFF for 5 to 10 seconds. Repeat this step ten times.

PRE-DELIVERY CHECKS

K. SET KNIFE SPEED

The knife speed is manually set by making adjustments to the knife drive pump, and has been pre-set at the factory. For optimum performance, adjust the knife speed according to the header being used. See the table below.

NOTE

The knife speed should stay within the range specified for each header.

HEADER DESCRIPTION		KNIFE SPEED			
TYPE	SIZE (FT)	MINIMUM		MAXIMUM	
		RPM	SPM	RPM	SPM
Draper DK	15	750	1500	950	1900
	20 and 25	700	1400	850	1700
	30	600	1200	800	1600
	35			700	1400
Draper SK	20 and 25	600	1200	750	1500
	30			700	1400
	35	550	1100	700	1400
Grass Seed	All	700	1400	975	1950
Auger A40-D		775	1550	925	1850
Auger A30-D		625	1250	775	1550
Auger A30-S					

RPM = speed of wobble box pulley.

SPM = strokes per minute of knife (RPM x 2).

- Start engine. See STEP 13. J. III. on page 41.
- Move throttle to adjust engine speed to IDLE.
- Set the Intermediate Speed Control (ISC) to OFF (see STEP 12. PROGRAM CDM).



- Push down on the yellow knob, and pull up on the black ring at the base of the switch.
- A slight delay between switch ON and operating speed is normal.

- Run engine at maximum rpm.
- Press SELECTOR button on the GSL until the CDM displays the knife speed in SPM (strokes per minute). This indicates that Optional Sensors Expansion Module B4666 is installed.

If knife speed is not displayed, the Module is not installed - proceed to step j. on next page.

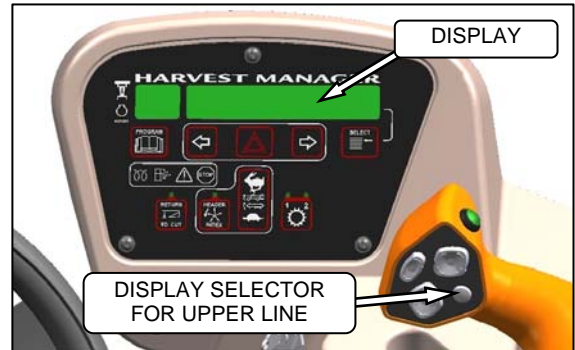

- Compare reading to the table opposite.
- If required, adjust knife speed as follows:



DANGER

Stop engine, and remove key from ignition before leaving Operator's seat for any reason. A child or even a pet could engage an idling machine.

- Shut down engine, and open engine hood.

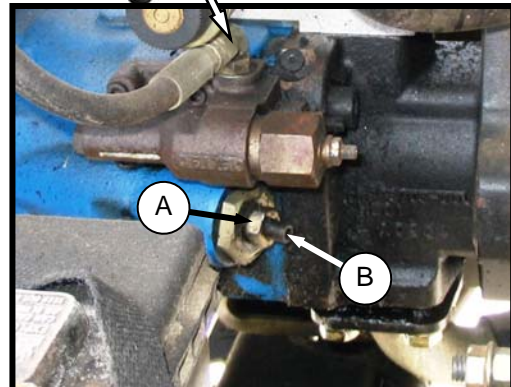

- Loosen jam-nut (A).
- Turn adjuster screw (B) clockwise (screw in) to decrease knife speed, and counter clockwise (screw out) to increase the knife speed.

(continued next page)

PRE-DELIVERY CHECKS

NOTE

One turn of the adjuster screw (B) will change the knife speed by approximately 116 strokes per minute, or the wobble box pulley speed by 58 revolutions per minute.

4. Once adjustment has been made, re-torque jam nut (A) as shown on previous page.
5. Close hood, start engine, and re-check knife speed.
- j. For windrowers not equipped with the Optional Sensors Expansion Module B4666:

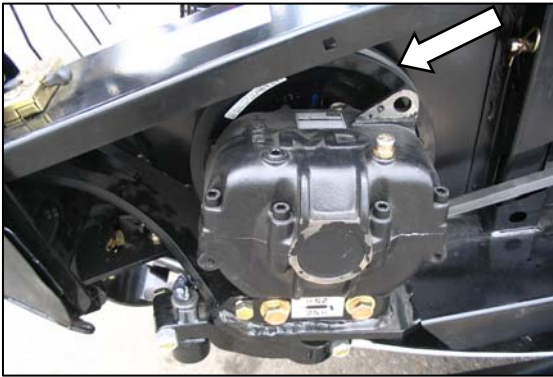

1. Check wobble box pulley speed with a hand-held tachometer.
2. Multiply the rpm reading by two for the knife speed in strokes per minute.
3. Compare reading to the table on the previous page.
4. If required, adjust knife speed. See step i. on previous page.

L. MANUALS

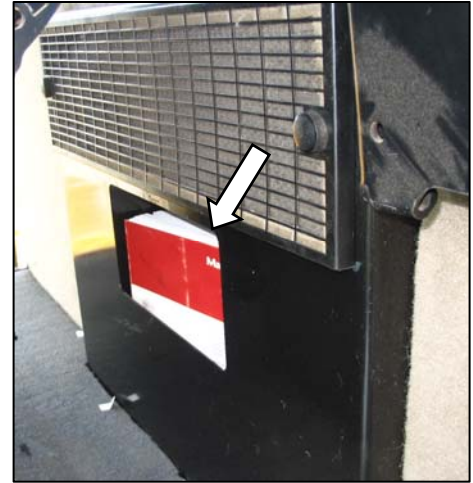

- a. The following manuals should be stored in the manual storage compartment behind the Operator's seat:

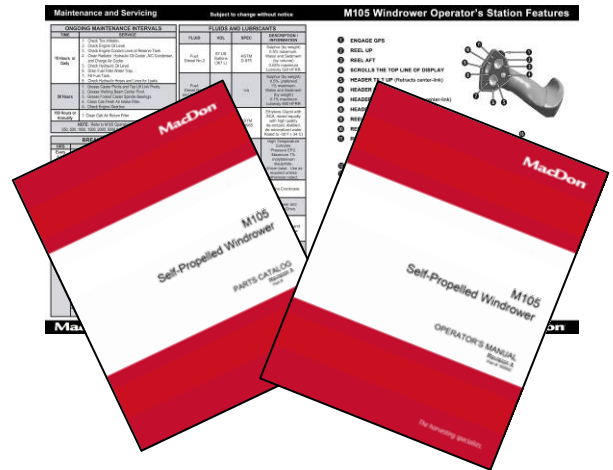

- M105 Self-Propelled Windrower PARTS CATALOG. See below.
- M105 Self-Propelled Windrower OPERATOR'S MANUAL. See below.
- Engine Manual 166240.
- M105 Windrower Quick Card 169570.
- Warranty documents.

WINDROWER	OPERATOR'S MANUAL	PARTS CATALOG
MacDon	169552	169549
Westward	169554	169550
Premier	169555	169551

M. CAB INTERIOR

- a. Remove plastic coverings from console, and seats after pre-delivery check is complete.

MacDon™

MacDon Industries Ltd.

680 Moray Street
Winnipeg, Manitoba
Canada R3J 3S3
t. (204) 885-5590
f. (204) 832-7749

MacDon Inc.

10708 N. Pomona Avenue
Kansas City, Missouri
United States 64153-1924
t. (816) 891-7313
f. (816) 891-7323

MacDon Australia Pty. Ltd.

A.C.N. 079 393 721
P.O. Box 243
Suite 3, 143 Main Street
Greensborough, Victoria
Australia 3088
t. 03 9432 9982
f. 03 9432 9972

CUSTOMERS

www.macdon.com

DEALERS

www.macdondealers.com

Trademarks of products are the marks of their
respective manufacturers and/or distributors.

Printed in Canada

M105 Self-Propelled Windrower Pre-Delivery Checklist - N.A.

Perform these checks and adjustments prior to delivery to your Customer. The completed Checklist should be retained either by the Operator or the Dealer.



CAUTION: Carefully follow the instructions given. Be alert for safety related messages which bring your attention to hazards and unsafe practices.

Windrower Serial Number: _____ Engine Serial Number: _____

✓	ITEM	PAGE
	Check for shipping damage or missing parts. Be sure all shipping dunnage is removed.	---
	Check for loose hardware. Tighten to required torque if necessary.	4
	Check tire air pressures and adjust as required.	37
	Check final drive hub lubricant level.	37
	Check engine coolant level and strength at recovery tank.	37
	Check air cleaner and clamps.	38
	Check hydraulic oil level, and check for leaks along lines.	38
	Check fuel separator for water and foreign material. Drain and clean as necessary. Add fuel.	38
	Check tension of A/C compressor belt.	39
	Check machine completely lubricated.	29
	Check Neutral Interlock system.	40
	Check engine warning lights at Cab Display Module.	41
START ENGINE AND RUN TO OPERATING TEMPERATURE		41
	Check Cab Display Module for operation.	42
	Check Operator's Presence System.	43
	Check alternator charge rate on CDM.	42
	Check air conditioning functioning properly.	45
	Check heater functioning properly.	45
	Check interior lights for operation.	44
	Check maximum (no load) engine speed at Cab Display Module: 2270 - 2330 rpm.	42
	Check exterior lights for operation.	43
	Complete the Header Pre-Delivery Checklist.	---
	Check that manuals are with the windrower.	47
	Check plastic coverings from cab interior removed.	47

Date Checked: _____

Checked by: _____