

C Series Corn Header

Unloading and Assembly Instructions (North America)

262816 Revision A

Original Instruction

C3808 Series Corn Header



Published October 2024.

© 2024 MacDon Industries, Ltd.

The information in this publication is based on the information available and in effect at the time of printing. MacDon Industries, Ltd. makes no representation or warranty of any kind, whether expressed or implied, with respect to the information in this publication. MacDon Industries, Ltd. reserves the right to make changes at any time without notice.

Introduction

This document describes the unloading, setup, and predelivery requirements for the MacDon C Series Corn Header.

To ensure your customers receive all of the performance and safety benefits from this product, carefully follow the unloading and assembly procedure from the beginning through to completion.

Retain this instruction for future reference.

If the shipment is damaged or is missing parts, contact shortageanddamage@macdon.com.

Conventions

The following conventions are used in this document:

- Right and left are determined from the operator's position. The front of the corn header faces the crop.
- Unless otherwise noted, use the standard torque values provided in Chapter [9.1 Torque Specifications, page 93](#). When torque values of 30 Nm or less are listed, their equivalents will be provided in both foot-pounds (lb·ft) and inch-pounds (lb·in).

Carefully read all the material provided before attempting to unload, assemble, or use the machine.

NOTE:

Keep your MacDon publications up-to-date. The most current version can be downloaded from our website (www.macdon.com) or from our Dealer-only site (<https://portal.macdon.com>) (login required).

This instruction is currently available in English only.

An instructional video can be streamed on [YouTube](#). This video contains supplementary information that should be viewed in combination with these instructions. Scanning the QR code with your smart device will take you to the video on YouTube.



Figure 1: QR Code Video Link

Summary of Changes

At MacDon, we're continually making improvements, and occasionally these improvements affect product documentation. The following list provides an account of major changes from the previous version of this document.

Section	Summary of Change	Internal Use Only
<i>Introduction, page i</i>	Added a link to the supplementary instructional video.	Product Support
<i>2 Header Specifications – C Series Corn Headers, page 7</i>	Updated the weight specified for the following models: C3012, C3812, C2018, and C2218.	Engineering
<i>3.2 Inspecting Header, page 12</i>	Added a photograph of the serial number plate.	Technical Publications
<i>4.1.1 Attaching Folding Frame Linkage – Folding Headers, page 17</i>	Added topic for assembling folding linkage for folding frame headers.	Product Support
<i>4.3 Lowering Header to Field Position, page 25</i>	Added important statement.	Engineering
<i>4.6 Removing Shipping Components, page 34</i>	Added an important note about ensuring that the folding frame linkage is connected.	Product Support
<i>4.7.1 Installing Standard End Dividers, page 36</i>	Added a cross reference to show wiring/routing for headers with auto header height control.	Technical Publications
<i>4.8 Installing Snouts and Snout Height Supports, page 42</i>	<ul style="list-style-type: none"> Added an image showing snout position mechanism for headers with 50 cm (20 in.) row spacing. Added an image to show wiring/routing for headers with auto header height control. 	Engineering
<i>8.1 Checking and Adjusting Orifices – Folding Headers, page 87</i>	Corrected details about hydraulic fittings orifice size.	Product Support
<i>5.12.1 Greasing Procedure, page 68</i>	Added detail about header grease points.	Product Support
<i>6.1 Recommended Sensor Output Voltages for Combines, page 73</i>	Added topic.	Product Support
<i>6.2 Adjusting Auto Header Height Sensor Voltage, page 74</i>	Added topic.	Product Support
<i>6.4 Configuring Challenger®, Gleaner®, and Massey Ferguson® Combines, page 77</i>	Added information about connecting harness pins when setting up Challenger®, Gleaner®, and Massey Ferguson® Combines.	Engineering
<i>6.6 Configuring IDEAL™ Combines, page 79</i>	Added information about connecting harness pins when setting up IDEAL™ combines.	Engineering
<i>6.3 Configuring Case IH Combines, page 75</i>	<ul style="list-style-type: none"> Added step for configuring combine display for folding frame. Added a list of required combine calibrations. 	Engineering
<i>6.3.1 Header Settings Quick Reference – Case AFX Display, page 75</i>	Added combine setup quick reference information.	Product Support
<i>7.1 Checking and Adjusting Row Guidance Sensor Clearance (Option), page 83</i>	Added topic.	Product Support

Section	Summary of Change	Internal Use Only
<i>6.8 Configuring New Holland Combines, page 81</i>	<ul style="list-style-type: none"> • Added step for configuring combine display for folding frame. • Added a list of features controlled by the multifunction handle. • Added a list of required combine calibrations. 	Engineering
<i>6.8.1 Header Settings Quick Reference – New Holland Display, page 81</i>	Added combine setup quick reference information.	Product Support
<i>7.2 Checking Row Guidance Sensor Voltage (Option), page 84</i>	Added topic.	Product Support
<i>7.3 Adjusting Row Guidance Sensor Voltage Orientation (Option), page 85</i>	Added topic.	Product Support
<i>8.2 Checking Folding Operation – Folding Headers, page 90</i>	Added illustration to highlight the locations of the cylinders used when folding/unfolding the header.	Technical Publications
<i>Predelivery Checklist, page 97</i>	Added row guidance check to the predelivery checklist.	Technical Publications

TABLE OF CONTENTS

Introduction	i
Summary of Changes.....	ii
Chapter 1: Safety	1
1.1 Safety Alert Symbols	1
1.2 Signal Words	2
1.3 General Safety	3
1.4 Hydraulic Safety	5
1.5 Safety Signs	6
Chapter 2: Header Specifications – C Series Corn Headers	7
Chapter 3: Unloading Header.....	11
3.1 Unloading Trailer.....	11
3.2 Inspecting Header.....	12
Chapter 4: Assembling Header.....	17
4.1 Preparing Header While in Standing Position.....	17
4.1.1 Attaching Folding Frame Linkage – Folding Headers	17
4.1.2 Checking and Adjusting Minimum Snapping Roll Knife Clearance.....	18
4.1.3 Checking and Adjusting Vine Knife Clearance	19
4.1.4 Checking and Adjusting Stalk Chopper	20
4.1.5 Adjusting Header Stands and Removing Parts Shipped on Bottom of Header.....	21
4.1.6 Checking and Adjusting Clearance Lights	22
4.2 Header Lifting Points.....	23
4.3 Lowering Header to Field Position	25
4.4 Preparing Header for Combine Attachment.....	26
4.5 Attaching Header to Combine.....	29
4.5.1 Adjusting Latching Hooks.....	29
4.5.2 Attaching Drivelines to Combine.....	32
4.5.3 Connecting Hydraulic and Electrical Systems.....	33
4.6 Removing Shipping Components	34
4.7 Installing End Dividers	36
4.7.1 Installing Standard End Dividers.....	36
4.7.2 Installing Rotary End Dividers	37
4.7.3 Installing Tall End Dividers	39
4.7.4 Checking and Adjusting End Divider Latches.....	41
4.8 Installing Snouts and Snout Height Supports.....	42
4.9 Installing Stubble Stompers (Option).....	48
Chapter 5: Performing Predelivery Checks.....	51
5.1 Checking and Adjusting Header Angle	51
5.2 Checking and Adjusting Snout Height	52

TABLE OF CONTENTS

5.3	Checking and Adjusting Snapping Plate Gap	53
5.4	Checking and Adjusting Rear Divider Latch	54
5.5	Checking and Adjusting Auger Flighting Configuration	56
5.6	Checking and Adjusting Auger Position	57
5.7	Checking and Adjusting Auger Drive Chain Tension	60
5.8	Checking and Adjusting Center Auger Timing – Two-Piece Augers	61
5.9	Checking and Adjusting Auger Debris Shield Angle	62
5.10	Checking and Adjusting Auger Timing – Folding Headers	63
5.11	Checking and Adjusting Fluid Levels	65
5.11.1	Checking and Adjusting Oil Level – Input Gearboxes	65
5.11.2	Checking and Adjusting Lubricant Level – Snapping Unit Gearbox	66
5.11.3	Checking and Adjusting Oil Level – Stalk Chopper Gearbox (Option)	67
5.12	Lubricating Header	68
5.12.1	Greasing Procedure	68
Chapter 6:	Configuring Combine	73
6.1	Recommended Sensor Output Voltages for Combines	73
6.2	Adjusting Auto Header Height Sensor Voltage	74
6.3	Configuring Case IH Combines	75
6.3.1	Header Settings Quick Reference – Case AFX Display	75
6.4	Configuring Challenger®, Gleaner®, and Massey Ferguson® Combines	77
6.5	Configuring CLAAS Combines	78
6.6	Configuring IDEAL™ Combines	79
6.7	Configuring John Deere Combines	80
6.8	Configuring New Holland Combines	81
6.8.1	Header Settings Quick Reference – New Holland Display	81
Chapter 7:	Setting up Row Guidance (Option)	83
7.1	Checking and Adjusting Row Guidance Sensor Clearance (Option)	83
7.2	Checking Row Guidance Sensor Voltage (Option)	84
7.3	Adjusting Row Guidance Sensor Voltage Orientation (Option)	85
Chapter 8:	Running up Header	87
8.1	Checking and Adjusting Orifices – Folding Headers	87
8.2	Checking Folding Operation – Folding Headers	90
Chapter 9:	Reference	93
9.1	Torque Specifications	93
9.1.1	Torque Specifications for Fasteners	93
9.1.2	Torque Specifications for Hydraulic Fittings	94
9.2	Conversion Chart	95
9.3	Definitions	96

TABLE OF CONTENTS

Predelivery Checklist 97
Recommended Fluids and Lubricants 99

Chapter 1: Safety

Understanding and consistently following these safety procedures will help to ensure the safety of those operating the machine and of bystanders.

1.1 Safety Alert Symbols

The safety alert symbol indicates important safety messages in this manual and on safety signs on the machine.

This symbol means:

- **ATTENTION!**
- **BECOME ALERT!**
- **YOUR SAFETY IS INVOLVED!**

Carefully read and follow the safety message accompanying this symbol.

Why is safety important to you?

- Accidents disable and kill
- Accidents cost
- Accidents can be avoided



Figure 1.1: Safety Symbol

1.2 Signal Words

Three signal words, **DANGER**, **WARNING**, and **CAUTION**, are used to alert you to hazardous situations. Two signal words, **IMPORTANT** and **NOTE**, identify non-safety related information.

Signal words are selected using the following guidelines:

DANGER

Indicates an imminently hazardous situation that, if it is not prevented, will result in death or serious injury.

WARNING

Indicates a potentially hazardous situation that, if it is not prevented, could result in death or serious injury. It may also be used to alert you to unsafe practices.

CAUTION

Indicates a potentially hazardous situation that, if it is not prevented, may result in minor or moderate injury. It may also be used to alert you to unsafe practices.

IMPORTANT:

Indicates a situation that, if not prevented, could result in a malfunction or damage to the machine.

NOTE:

Provides additional information or advice.

1.3 General Safety

Operating, servicing, and assembling machinery presents several safety risks. These risks can be reduced or eliminated by following the relevant safety procedures and wearing the appropriate personal protective equipment.

CAUTION

The following general farm safety precautions should be part of your operating procedure for all types of machinery.

Wear all protective clothing and personal safety devices that could be necessary for the job at hand. Do **NOT** take chances. You may need the following:

- Hard hat
- Protective footwear with slip-resistant soles
- Protective glasses or goggles
- Heavy gloves
- Wet weather gear
- Respirator or filter mask

In addition, take the following precautions:

- Be aware that exposure to loud noises can cause hearing impairment. Wear suitable hearing protection devices such as earmuffs or earplugs to help protect against loud noises.



Figure 1.2: Safety Equipment



Figure 1.3: Safety Equipment

- Provide a first aid kit in case of emergencies.
- Keep a properly maintained fire extinguisher on the machine. Familiarize yourself with its use.
- Keep young children away from machinery at all times.
- Be aware that accidents often happen when Operators are fatigued or in a hurry. Take time to consider the safest way to accomplish a task. **NEVER** ignore the signs of fatigue.

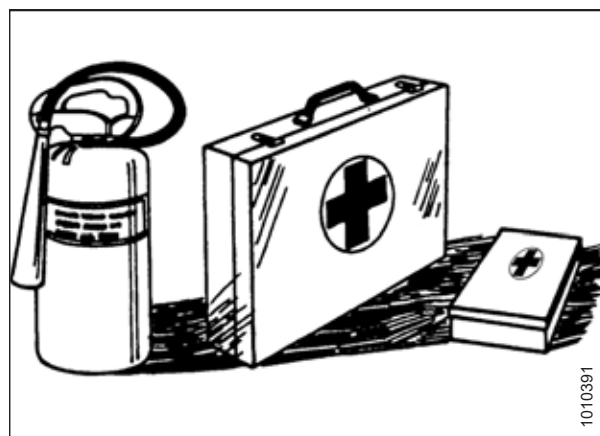

Figure 1.4: Safety Equipment

SAFETY

- Wear close-fitting clothing and cover long hair. **NEVER** wear dangling items such as hoodies, scarves, or bracelets.
- Keep all shields in place. **NEVER** alter or remove safety equipment. Ensure that the driveline guards can rotate independently of their shaft, and that they can telescope freely.
- Use only service and repair parts made or approved by the equipment manufacturer. Parts from other manufacturers may not meet the correct strength, design, or safety requirements.



Figure 1.5: Safety around Equipment

- Keep hands, feet, clothing, and hair away from moving parts. **NEVER** attempt to clear obstructions or objects from a machine while the engine is running.
- Do **NOT** modify the machine. Unauthorized modifications may impair the functionality and/or safety of the machine. It may also shorten the machine's service life.
- To avoid injury or death from the unexpected startup of the machine, **ALWAYS** stop the engine and remove the key from the ignition before leaving the operator's seat for any reason.

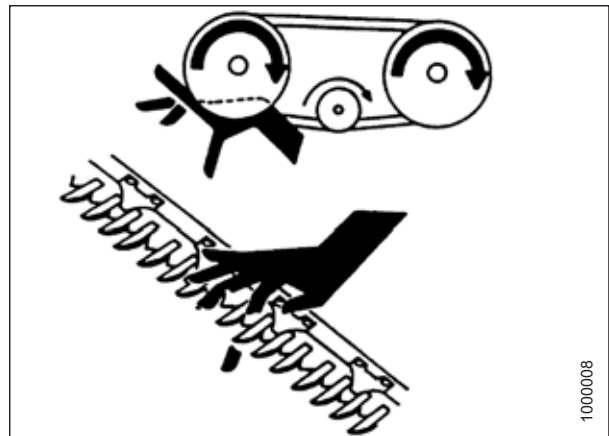

Figure 1.6: Safety around Equipment

- Keep the machine service area clean and dry. Wet and/or oily floors are slippery. Wet spots can be dangerous when working with electrical equipment. Ensure that all electrical outlets and tools are properly grounded.
- Keep the work area well-lit.
- Keep machinery clean. Straw and chaff on a hot engine are fire hazards. Do **NOT** allow oil or grease to accumulate on service platforms, ladders, or controls. Clean machines before they are stored.
- **NEVER** use gasoline, naphtha, or any volatile material for cleaning purposes. These materials may be toxic and/or flammable.
- When storing machinery, cover any sharp or extending components to prevent injury from accidental contact.



Figure 1.7: Safety around Equipment

1.4 Hydraulic Safety

Because hydraulic fluid is under extreme pressure, hydraulic fluid leaks can be very dangerous. Follow the proper safety procedures when inspecting hydraulic fluid leaks and servicing hydraulic equipment.

- Always place all hydraulic controls in **NEUTRAL** before leaving the operator's seat.
- Ensure that all of the components in the hydraulic system are kept clean and in good condition.
- Replace any worn, cut, abraded, flattened, or crimped hoses and steel lines.
- Do **NOT** attempt any makeshift repairs to hydraulic lines, fittings, or hoses by using tapes, clamps, cements, or welding. The hydraulic system operates under extremely high pressure. Makeshift repairs can fail suddenly and create hazardous conditions.



Figure 1.8: Testing for Hydraulic Leaks

- Wear proper hand and eye protection when searching for high-pressure hydraulic fluid leaks. Use a piece of cardboard as a backstop instead of your hands to isolate and identify a leak.
- If you are injured by a concentrated, high-pressure stream of hydraulic fluid, seek medical attention immediately. Serious infection or a toxic reaction can develop from hydraulic fluid piercing the skin.



Figure 1.9: Hydraulic Pressure Hazard

- Ensure that all components are tight and that steel lines, hoses, and couplings are in good condition before applying pressure to a hydraulic system.

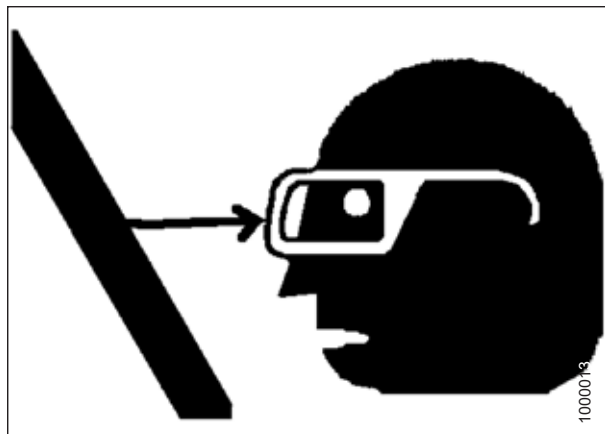

Figure 1.10: Safety around Equipment

1.5 Safety Signs

Safety signs are decals placed on the machine where there is a risk of personal injury, or where the Operator should take extra precautions before operating the controls. They are usually yellow.

- Keep safety signs clean and legible at all times.
- Replace safety signs that are missing or illegible.
- If the original part on which a safety sign was installed is replaced, ensure that the repair part displays the current safety sign.

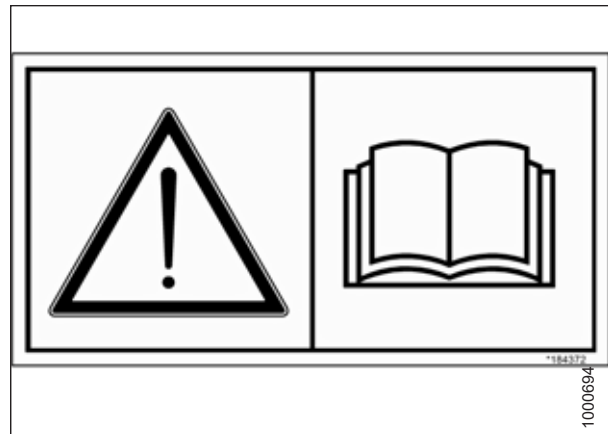

Figure 1.11: Operator's Manual Decal

Chapter 2: Header Specifications – C Series Corn Headers

The dimensions and weights of the various C Series Corn Headers are provided here.



DANGER

The equipment used for loading or unloading a machine must meet or exceed the requirements specified in this document. Using inadequate equipment may result in chain breakage, vehicle tipping, machine damage, and bodily harm to operators or bystanders.

HEADER SPECIFICATIONS – C SERIES CORN HEADERS

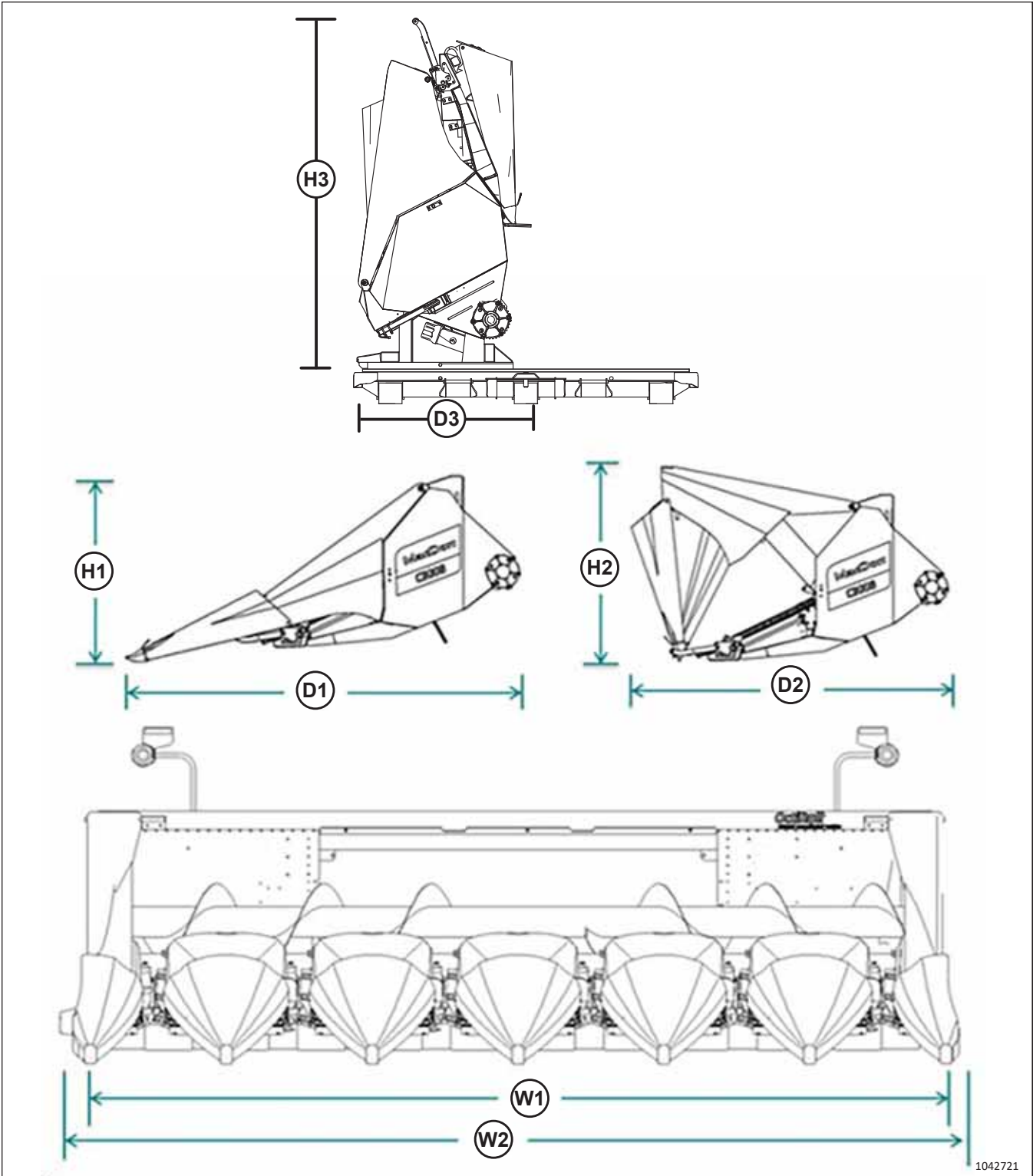

1042721

Figure 2.1: Header Dimensions

D1 - Header Length in Field Configuration

D3 - Header Length in Shipping Configuration

H2 - Header Height in Transport Configuration

W1 - Effective Harvesting Width

D2 - Header Length in Transport Configuration

H1 - Header Height in Field Configuration

H3 - Header Height in Shipping Configuration

W2 - Overall Header Width

HEADER SPECIFICATIONS – C SERIES CORN HEADERS

Table 2.1 Header Dimensions – All Models

Header Type	Length in Field Configuration (D1)		Length in Shipping Configuration (D3) ²		Length in Transport Configuration ¹ (D2)		Height in Field Configuration (H1)		Height in Shipping Configuration (H3) ²		Height in Transport Configuration ¹ (H2)	
	m	ft.	m	ft.	m	ft.	m	ft.	m	ft.	m	ft.
Rigid	2.97	9.7	1.10	3.6	1.10	3.6	1.45	4.8	2.45	8.0	2.43	8.0
Folding	2.97	9.7	1.20	3.9	1.10	3.6	1.58	5.2	2.45	8.0	2.43	8.0

Table 2.2 Rigid Header Dimensions

Row Spec.	Model ³	Weight		Effective Harvesting Width (W1)		Overall Width (W2)	
		kg	lb.	m	ft.	m	ft.
6R30	C3006	2073	4570	4.57	15.00	4.63	15.20
	C3006C	2180	4800	4.57	15.00	4.70	15.42
8R22	C2208	2140	4720	4.47	14.67	4.74	15.53
	C2208C	2260	4982	4.47	14.67	4.80	15.75
8R30	C3008	2968	6543	6.10	20.00	6.16	20.20
	C3008C	3110	6856	6.10	20.00	6.22	20.42
8R38	C3808	2900	6390	7.72	25.33	7.58	24.87
	C3808C	3080	6790	7.72	25.33	7.65	25.08
12R20	C2012	2890	6370	6.10	20.00	6.41	21.03
	C2012C	3050	6724	6.10	20.00	6.48	21.25
12R22	C2212	3325	7330	6.71	22.00	6.97	22.87
	C2212C	3630	8000	6.71	22.00	7.04	23.08
12R30	C3012	3723	8869	9.14	30.00	9.21	30.20
	C3012C	4120	9083	9.14	30.00	9.27	30.42
12R38	C3812	4197	9253	11.58	38.00	11.44	37.53
	C3812C	4290	9458	11.58	38.00	11.51	37.75
16R30	C3016	5060	11,155	12.19	40.00	12.25	40.20
	C3016C	5330	11,751	12.19	40.00	12.32	40.42
18R20	C2018	4292	9462	9.14	30.00	9.46	31.03
	C2018C	4480	9877	9.14	30.00	9.53	31.25
18R22	C2218	5036	11,102	10.06	33.00	10.33	33.87
	C2218C	5225	11,519	10.06	33.00	10.39	34.08

1. Transport configuration is used when transporting the header between fields, after unloading and assembly tasks are complete.
2. Shipping configuration is the configuration of the header when it is shipped from the factory.
3. Model numbers ending in “C” indicate that the header is equipped with a chopper.

HEADER SPECIFICATIONS – C SERIES CORN HEADERS

Table 2.3 Folding Header Dimensions

Row Spec.	Model ⁴	Weight		Folded Width		Effective Harvesting Width (W1)		Overall Width (W2)	
		kg	lb.	m	ft.	m	ft.	m	ft.
8R30	C3008F	3218	7094	3.23	10.6	6.10	20.00	6.16	20.20
	C3008CF	3360	7408	3.23	10.6	6.10	20.00	6.22	20.42
12R30	CR012F	4156	9162	4.75	15.6	9.14	30.00	9.21	30.20
	CR012CF	4370	9634	4.75	15.6	9.14	30.00	9.27	30.42

4. Model numbers ending in "F" indicate that the header folds; model numbers ending in "CF" indicate that the header folds and is equipped with a chopper.

Chapter 3: Unloading Header

These instructions are to be followed when receiving a C Series Corn Header and preparing it for field use.

3.1 Unloading Trailer

Normally, two C Series Corn Headers are shipped together in an upright position on a trailer. Follow these procedures when unloading them from the trailer.

DANGER

The equipment used for loading or unloading a machine must meet or exceed the requirements specified in this document. Using inadequate equipment may result in chain breakage, vehicle tipping, machine damage, and bodily harm to operators or bystanders.

To determine the equipment needed to handle the headers, refer to *2 Header Specifications – C Series Corn Headers, page 7*.

To unload the headers from the trailer, follow these steps:

1. Move the trailer into position and block the trailer's wheels.
2. Lower the trailer storage stands.
3. Approach the header with a forklift and line up the forks with the fork slider channels under the shipping stand.
4. Slide the forks underneath the fork slider channels as far as possible without contacting the shipping support of the second header, if present.
5. Remove the tie-down straps, chains, and wooden blocks.
6. Slowly raise the header off of the trailer deck.
7. Back the forklift away from the trailer until the header clears the trailer. Slowly lower the header until it is 254 mm (10 in.) above the ground.
8. Take the header to the storage area. Set the header down securely on level ground free of rocks and debris.
9. Repeat this procedure to unload the second header, if present.

3.2 Inspecting Header

Once unloaded, each header must be inspected to ensure that the order was received in its entirety and without damage.

1. Inspect the following items to ensure that they are present and correct:

- Serial number (located on plate [A] the left end of the header, on the top face of the top beam)



Figure 3.1: Serial Number Plate

- Main driveline guard – ensure it is properly seated to the gearbox



Figure 3.2: Main Driveline Guard – Correctly Seated



Figure 3.3: Main Driveline Guard – Incorrectly Seated

UNLOADING HEADER

- Driveshaft and gearbox – ensure they are configured for the correct combine (the gear tooth configuration [A] is written or stamped on the gearbox’s aluminum housing; you may need to remove the cover to see it); refer to Table 3.1, page 13.

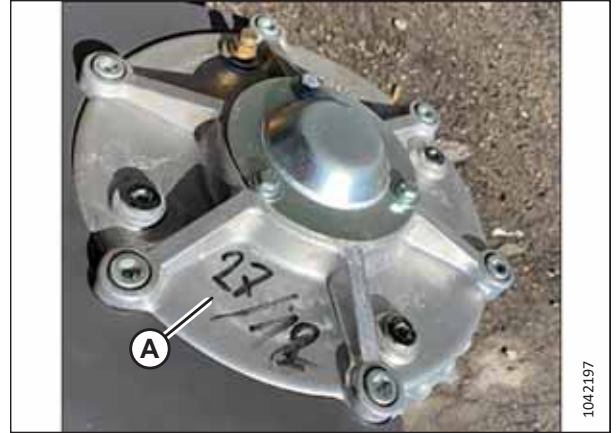

Figure 3.4: Gearbox Configuration

Table 3.1 Driveshaft and Gearbox Configurations

Combine	Drive	Gearbox Ratio	Driveshaft
Case IH 1600 and 2000 Series	—	27T/11T	1 1/8 hex
Case and New Holland (2016 and earlier)	—	27T/12T	1 3/8 - 6 spline
Case and New Holland (2017 and later)	—	27T/12T	1 3/8 - 21 spline
CLAAS	—	27T/15T	1 3/8 - 21 spline
Gleaner®	Fixed	27T/15T	1 3/8 - 21 spline
	Variable	27T/18T	1 3/8 - 21 spline
IDEAL™	Fixed	27T/15T	1 3/4 - 20 spline
	Variable	27T/18T	1 3/4 - 20 spline
John Deere	Fixed	27T/11T	1 3/8 - 21 spline
	Variable	27T/15T	1 3/8 - 21 spline
Massey Ferguson®	Fixed	27T/15T	1 3/8 - 21 spline
	Variable	27T/18T	1 3/8 - 21 spline

UNLOADING HEADER

- Parts shipped in wooden crate (A):
 - Wire snout brackets (headers with 76 cm [30 in.] row spacing only)
 - Auger paddle/finger kit
 - Chopper wrench (headers configured with stalk choppers)
 - Gathering chain tool (folding headers only; shipped in the toolbox on rigid and flex headers. Refer to Figure .)
 - Alternate orifices for folding cylinders (folding headers)
 - Yellow MacDon decals (headers configured for Case or New Holland combines)
 - Folding switch (folding headers configured for CLAAS combines)

NOTE:

Figure 3.5, page 14 shows the header still on the header cart. The header should have been removed from the cart before it was delivered to the dealership.

NOTE:

Toolbox (A) shown in Figure 3.6, page 14 is not installed on folding headers.

- Manuals located in the manual canister:
 - Operator's manual
 - Parts catalog



Figure 3.5: Wooden Shipping Crate

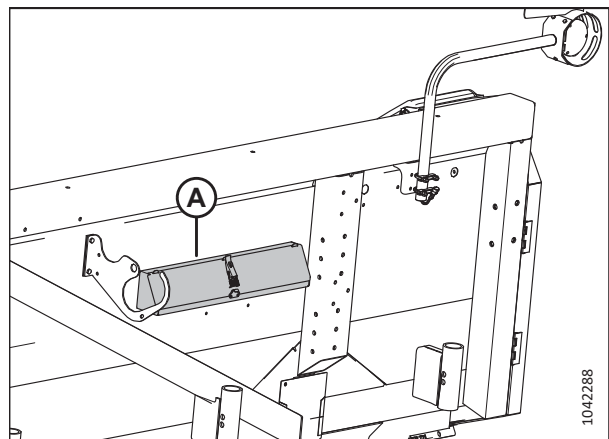

Figure 3.6: Toolbox on Back of Header



Figure 3.7: Operator's Manual

UNLOADING HEADER

- Combine configuration — ensure the electrical and hydraulic completion parts are appropriate for the combine type
 - Special configurations, for example:
 - Snout color
 - Rotary end dividers (REDs)
 - Stubble stompers
 - Tall end dividers (TEDs)
 - Row guidance
 - Auto header height control (AHHC)
2. Check for shipping damage, for example:
- Missing or damaged snouts
 - Decals that are peeling, bubbling, or scratched
 - Scuffed paint (touch up if possible)
 - Missing hardware or parts (toolbox cover, gathering chain tool, etc.)
 - Bent or damaged parts (snout support brackets, header field stands, clearance lights, etc.)
3. If the shipment is incorrect, damaged, or missing parts, send an itemized list and photographs to *[Missing cross reference text]*.

Chapter 4: Assembling Header

Follow these procedures when preparing a C Series Corn Header for field use.

4.1 Preparing Header While in Standing Position

Some assembly tasks are best done before lowering the header into field position.

1. Ensure that the assembly area is flat and free of rocks or debris that could damage the header. If necessary, move the header to a more suitable location.
2. Remove the wooden crate from the header shipping stand and set it aside.
3. If preparing a non-folding header, proceed to [4.1.2 Checking and Adjusting Minimum Snapping Roll Knife Clearance](#), page 18.

4.1.1 Attaching Folding Frame Linkage – Folding Headers

Some header configurations are shipped with the folding frame linkage disconnected from the frame. This linkage must be connected before removing the folding frame shipping locks and lowering the header to field position.

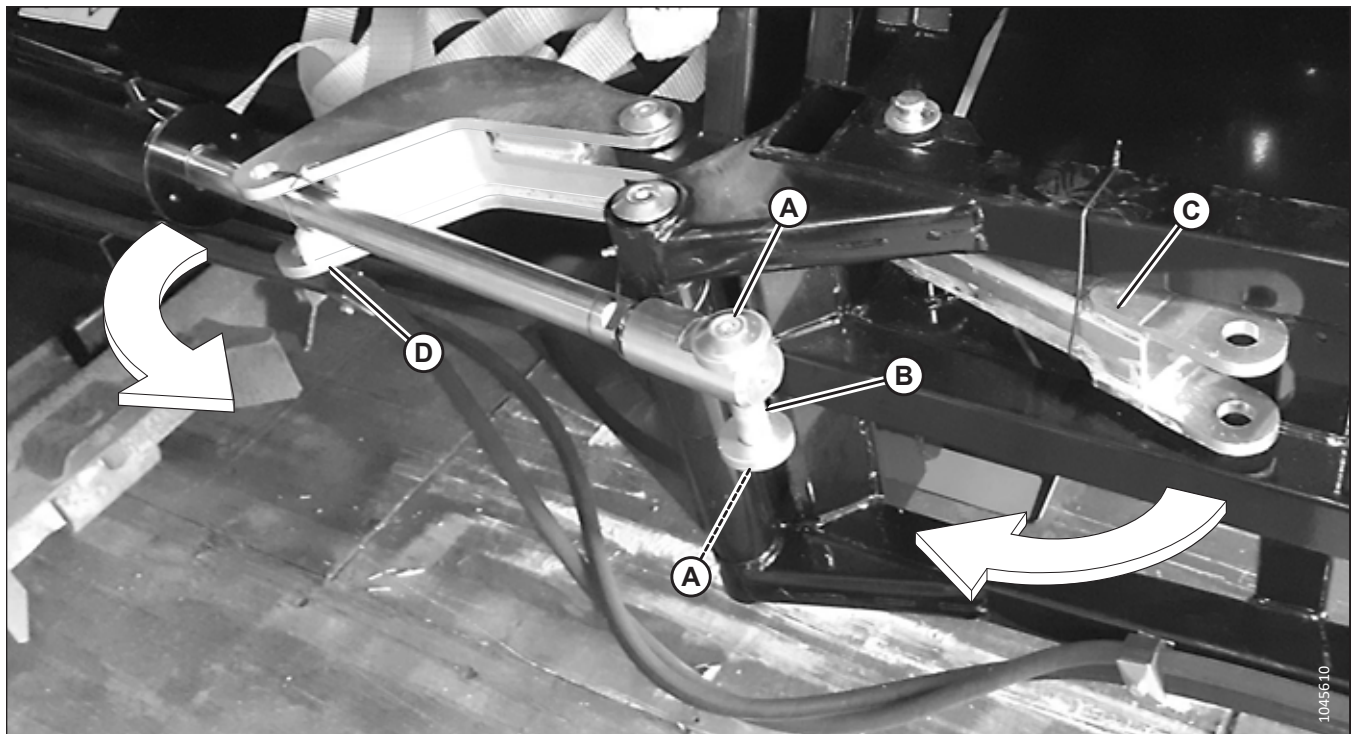

Figure 4.1: Folding Frame Linkage – Left Side

1. Remove bolts (A), washers, and pin (B) from the cylinder clevis.
2. Remove shipping wire and rotate brackets (C) and (D) inward to engage the cylinder clevis.

ASSEMBLING HEADER

3. Insert pin (A) through the brackets and cylinder clevis.
4. Apply medium-strength threadlocker (Loctite® 243 or equivalent) to bolts (C) and secure pin with washers (B) and bolts.
5. Torque bolts to 63 Nm (46 lbf·ft).
6. Repeat on the opposite side of the header frame.

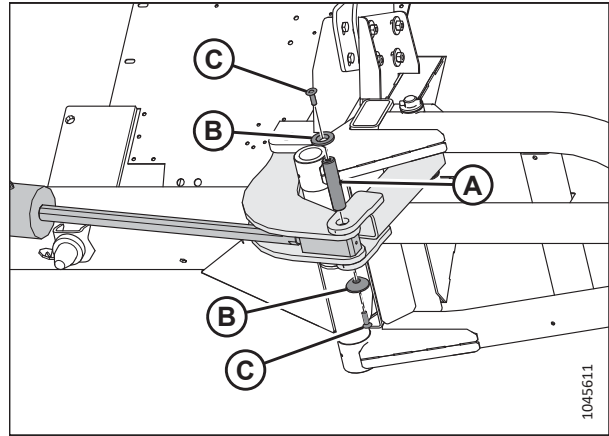

Figure 4.2: Folding Frame Linkage – Left Side

4.1.2 Checking and Adjusting Minimum Snapping Roll Knife Clearance

There is a snapping unit assembly between each pair of snouts, and each assembly contains two snapping rolls with attached knives. The clearance between those knives should be checked, and if necessary adjusted, before lowering the header into field position.

CAUTION

Wear heavy gloves when working around or handling knives.

CAUTION

Ensure hands are clear when rotating snapping rolls. When you rotate one, others will rotate as well.

1. There is a pair of snapping rolls in each row. Rotate snapping rolls (A) and check the clearance between each pair. There should be a 1–2 mm (0.04–0.08 in.) gap (B) between opposing sharp knives.

NOTE:

If the header is equipped with a stalk chopper, you can rotate the snapping rolls by hand by turning the chopper assembly. If the header is not equipped with a stalk chopper, use a 32 mm wrench to turn the input hex shaft.

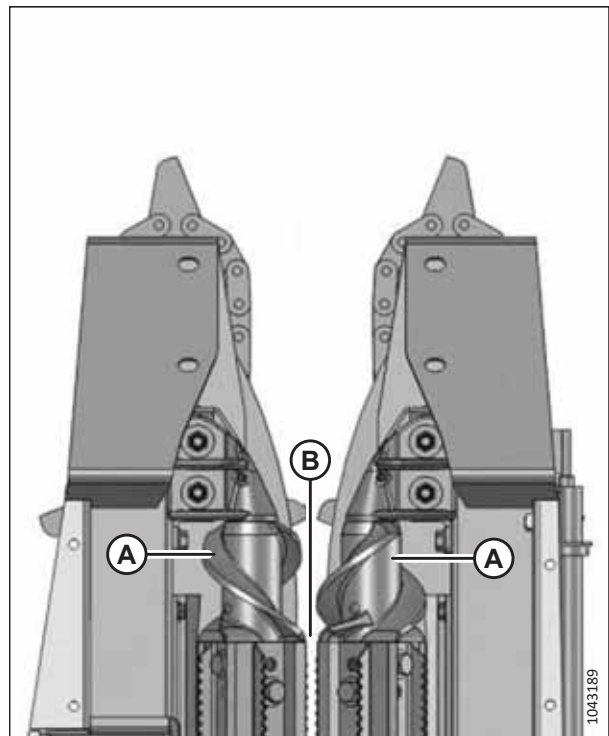

Figure 4.3: Snapping Roll Knife Clearance

ASSEMBLING HEADER

2. If the clearance is inadequate, adjust the front of each snapping roll (A) as follows:
 - a. Slightly loosen bolts (C) holding the snapping roll front support.
 - b. Using a pry bar, slide the roll to adjust the gap between the opposing knives, and then retighten bolts (C).
 - c. Repeat these steps on the second snapping roll. Make sure both rolls are adjusted the same amount. Gap (B) between the opposing knives should now be 1–2 mm (0.04–0.08 in.).
 - d. Torque the nuts to 45 Nm (33 lbf·ft).
 - e. After both rolls have been adjusted, rotate the rolls a full revolution to ensure that there is no contact between the knives.

NOTE:

The rear of the snapping roll is fixed in place and cannot be adjusted.

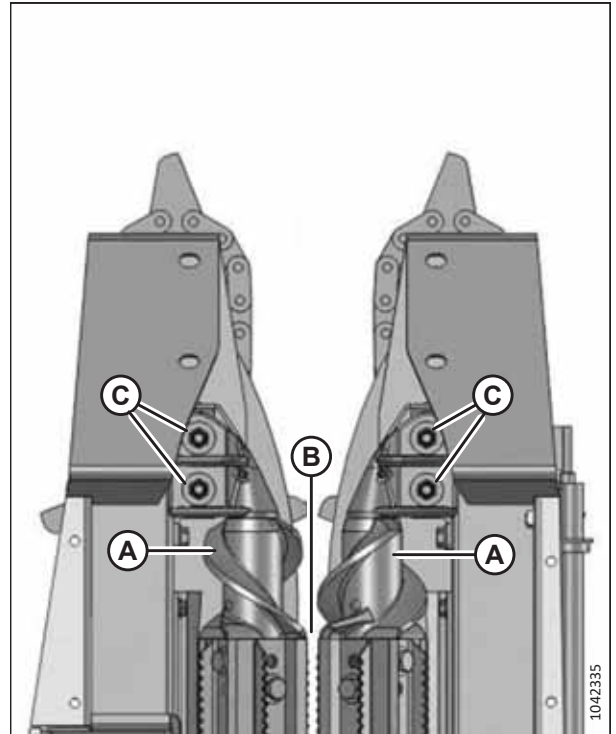

Figure 4.4: Snapping Roll Knife Clearance

4.1.3 Checking and Adjusting Vine Knife Clearance

The clearance between the snapping rolls and the vine knives should be checked, and if necessary adjusted, before lowering the header into field position.

CAUTION

Wear heavy gloves when working around or handling knives.

1. Rotate the snapping rolls again, and this time check the clearance between the rolls and the vine knives (A) and (B). The gap (C) should be 1–2 mm (0.04–0.08 in.).

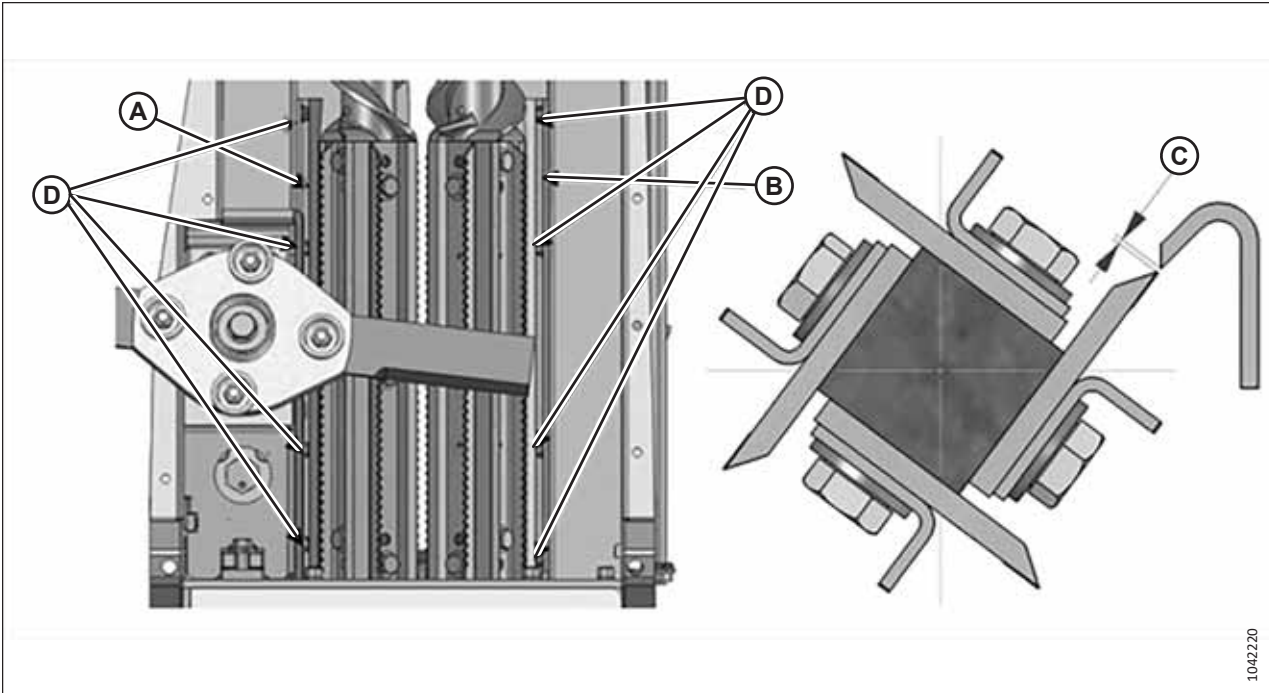

Figure 4.5: Vine Knives

2. If the clearance is incorrect, adjust the position of the vine knives as follows:
 - a. Loosen the four M8 bolts (D) securing one of the vine knives in place.
 - b. Adjust the position of the knife, then retighten the bolts.
 - c. Rotate the rolls a full revolution to ensure that there is no interference and that clearance gap (C) is now correct.
3. If assembling a header without the stalk chopper option, proceed to [4.1.5 Adjusting Header Stands and Removing Parts Shipped on Bottom of Header, page 21](#).

4.1.4 Checking and Adjusting Stalk Chopper

The stalk chopper should be checked, and if necessary adjusted, before lowering the header into field position. Headers with a letter "C" after the model number (e.g., C3808C") are equipped with the stalk chopper feature.

WARNING

Stalk choppers have sharp edges. Wear heavy, cut-proof gloves when working around or handling choppers.

NOTE:

A chopper wrench should be supplied with every header equipped with stalk choppers. It should have been shipped in the wooden shipping crate (on folding headers) or in the header toolbox (on rigid headers).

ASSEMBLING HEADER

1. Put on heavy, cut-proof gloves.
2. To check if the stalk chopper is engaged or disengaged, grab the center of stalk chopper (A) and rotate it. If the chopper is engaged, the snapping rolls should rotate with the chopper.
3. If the stalk chopper is disengaged, turn hex knob (B) 180 degrees to engage it. Repeat this adjustment on every row.
4. Once you have ensured that the stalk chopper is engaged, grab each chopper knife (C) in turn, and rotate the knives to make sure they do not bind. Stalk chopper knives must move freely.

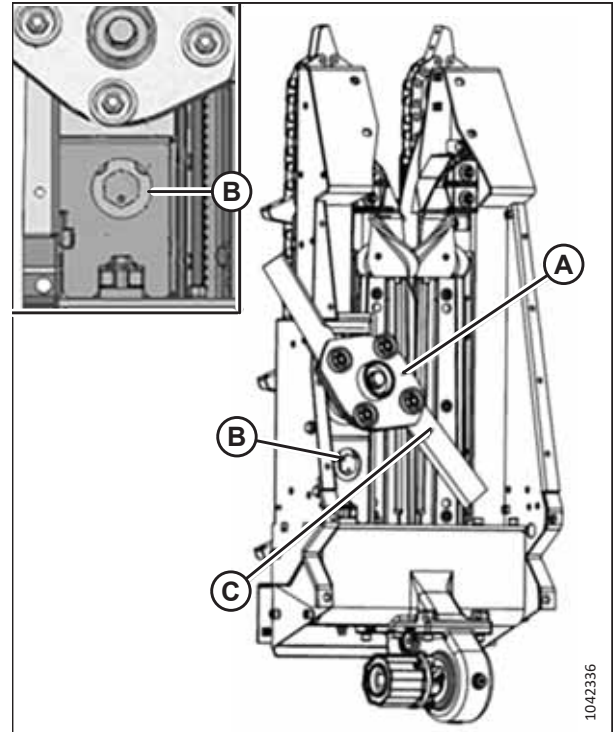

Figure 4.6: Stalk Chopper

4.1.5 Adjusting Header Stands and Removing Parts Shipped on Bottom of Header

The header stands need to be adjusted and some parts removed from the bottom of the header before lowering the header into field position.

1. Lower header stands (A) until the tops are flush with the top of the mount (B) to protect the bottom of the snapping units and stalk choppers.

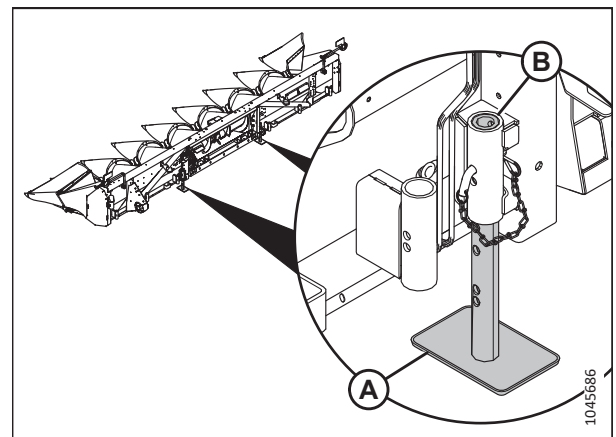

Figure 4.7: Header Stand

ASSEMBLING HEADER

2. Remove any snouts and/or tall end dividers (TEDs) (A) that are secured to the bottom of the header for shipping. Set them aside for later installation.



Figure 4.8: Bottom of Header in Shipping Configuration

4.1.6 Checking and Adjusting Clearance Lights

Ensure the clearance lights are positioned in such a way that they won't be damaged when the header is lowered into field position.

1. Check if clearance lights (A) on each end of the header are pushed tight to the backsheet. If necessary, loosen four nuts (B), then slide the light inboard and upward. Retighten the nuts.

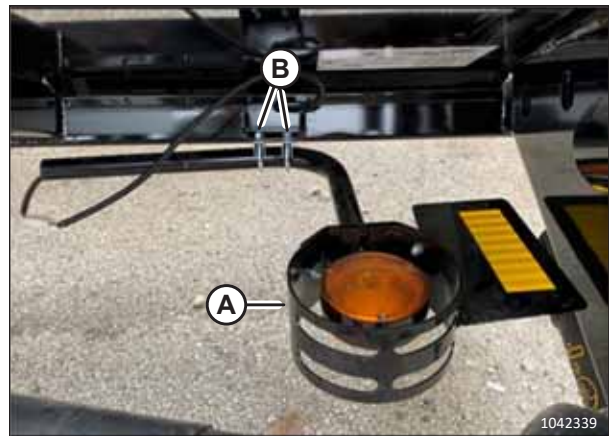

Figure 4.9: Clearance Lights

4.2 Header Lifting Points

The header can be lifted with either a forklift or a crane. It should only be lifted using the lifting points identified below.

Use an appropriately sized forklift or crane and cables to lift and move the header. For header dimensions and weight, refer to *2 Header Specifications – C Series Corn Headers, page 7*.

Lifting from header stand

When using a forklift, ensure the forks are fully seated in the channels when moving headers on stands.

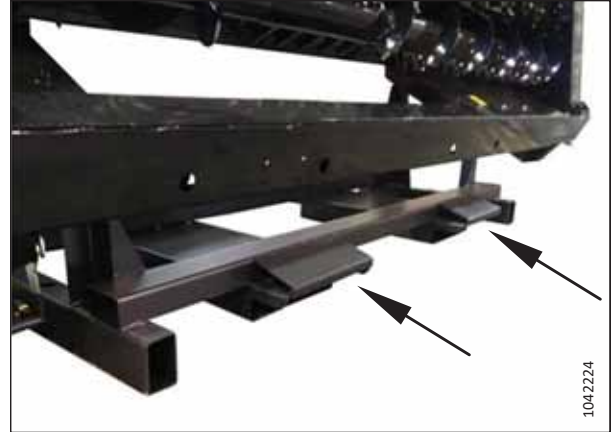

Figure 4.10: Forklift Channels in Header Stand

Lifting from lifting bar(s)

Headers will arrive with one or two lifting bars bolted to the underside of the row units.

For headers with a single lifting bar, use an appropriately rated rigging hooked at both lifting bar hooks (A).

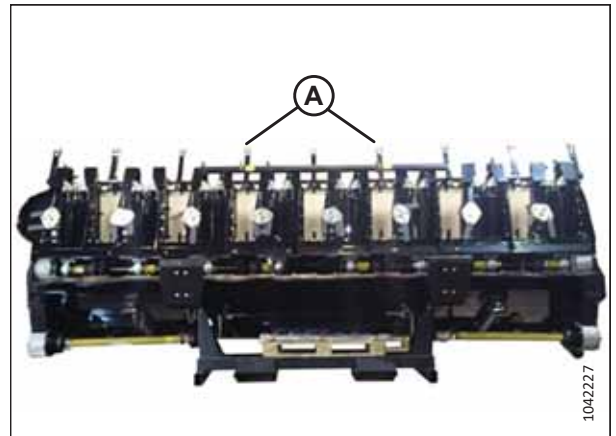

Figure 4.11: Header with Single Lifting Bar

ASSEMBLING HEADER

For headers using two lifting bars, use an appropriately rated rigging hooked at all four lifting points, and make sure angle (A), between the cables and/or chains, is less than 90° .

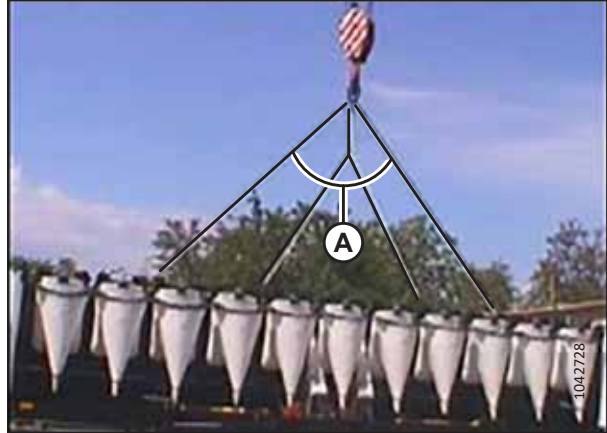

Figure 4.12: Header with Two Lifting Bars

4.3 Lowering Header to Field Position

The headers are shipped upright and will need to be lowered to the ground so that final assembly procedures can be performed.

1. Ensure that the assembly area is flat and free of rocks or debris that could damage the header. If necessary, move the header to a more suitable location.
2. Attach a lifting device to the header as described in [4.2 Header Lifting Points, page 23](#).

IMPORTANT:

Ensure that the lifting device rigging does **NOT** contact the snout supports as the header is tipped. If needed, snout supports can be removed inboard of the rigging to prevent damage.

3. Use the lifting device and cables to tip the header down into field position.

4.4 Preparing Header for Combine Attachment

Certain assembly tasks must be completed after the header is lowered into field position but before it is attached to a combine.

Removing header stand

1. If applicable, remove adjustable strap (A) securing the bulkhead lines to the header stand.

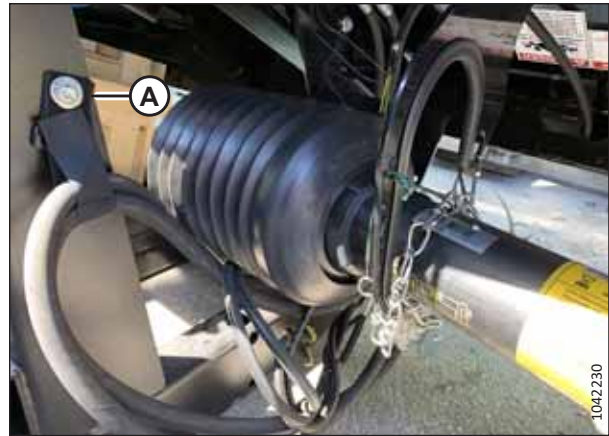

Figure 4.13: Adjustable Strap

2. While header stand (A) is supported by a forklift or crane, remove and discard the four M16 bolts securing the stand to the header.
3. Remove header stand (A) from the back of the header.



Figure 4.14: Removing Header Stand

Repositioning driveline storage bracket

4. One or two driveline storage brackets are installed high on the back of the header frame, secured to holes (A) on either side of the delivery opening, for shipping. This position is ideal for C2008, C2208, C3006, C2212, and C3012F headers configured for Lexion combines.

Depending on the combine model and header configuration, you may need to reposition the driveline holder lower, securing it to holes (B), to avoid interference when in the storage and operational positions.

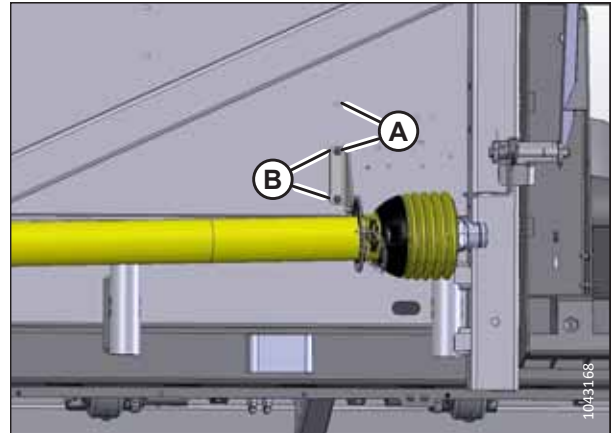

Figure 4.15: Driveline Storage Bracket in Lower Position

Repositioning clearance lights

5. Remove U-bolts (A) securing clearance light (B) in shipping position.

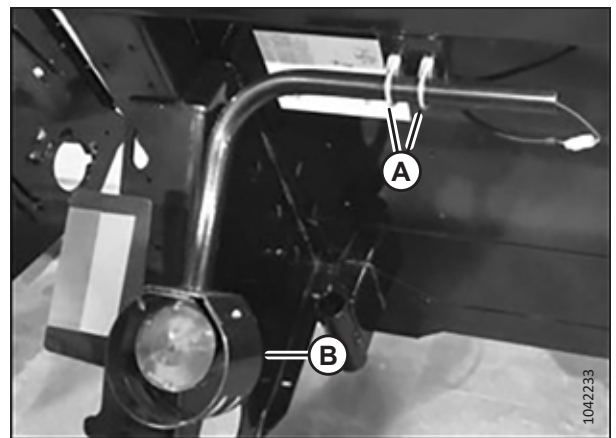

Figure 4.16: Clearance Light – Shipping Position

6. Rotate light (B) up to field position, ensuring that the yellow reflector faces forward.
7. Reinstall U-bolts (A) to secure light (B) in field position. Leave the U-bolts slightly loose so that the lights can rotate to prevent damage if they contact anything.
8. Repeat Steps 5, page 27 to 7, page 27 to reposition the clearance light at the other end of the header.

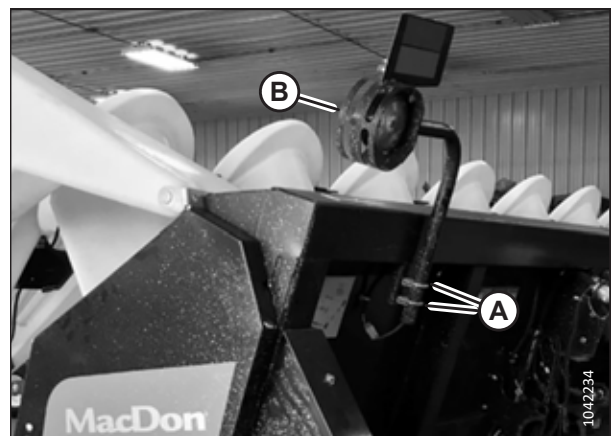

Figure 4.17: Clearance Light – Field Position

ASSEMBLING HEADER

Trimming transition frame seal — John Deere only

9. Lower transition frame seals (A) may overlap the feeder house opening on some John Deere combines. If necessary, trim the edges of the seals to match the feeder house opening width.



Figure 4.18: Too Large Transition Frame Seal

4.5 Attaching Header to Combine

The header must be attached to a combine before assembly can be completed.

IMPORTANT:

Headers are shipped already configured for a specific combine brand. If the header will be attached to a different combine brand, remove the factory-installed mounting kit and install the mounting kit recommended for the new combine brand before attaching the header to the combine.

NOTE:

Ensure that the combine feeder house's lugs are free of dirt and debris. Check the locking mechanism for freedom of movement, and ensure that it is free of damage; make any necessary repairs to the locking mechanism before attaching the header to the combine.

NOTE:

Ensure that all electrical and hydraulic connectors are clean and free of dust and debris.

1. Engage and securely attach the header to the combine following the instructions provided in the combine operator's manual.
2. Engage the header safety props. For instructions, refer to the combine operator's manual.

4.5.1 Adjusting Latching Hooks

After picking up the header with the combine, you will need to adjust the latching hooks, which are specific to each combine model. Ensure the locking pins are securely seated before proceeding.

Refer to the applicable instructions for your combine model below.

Case IH 1000–2000

1. Locate the U-bolts on the transition frame on the rear of the header, just below the outboard corners of the delivery opening.
2. Adjust nuts (A) on the U-bolts as required to provide adequate clamping force. Refer to the combine operator's manual for the correct adjustments and latching methods.

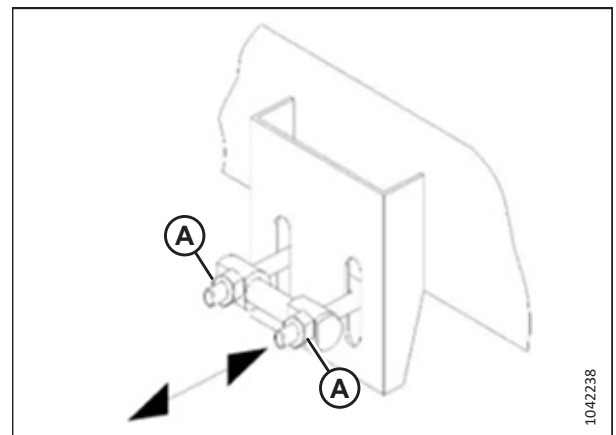

Figure 4.19: U-bolts – Case IH 1000–2000

ASSEMBLING HEADER

Case IH Flagship and Legacy, New Holland CR and CX Series

1. Adjust hooks (A) on the combine until they are fully seated in the holes of the header.
2. Put combine locking arm (B) in header latch (C), and then tighten lower bolts (D).

NOTE:

Some combines have two of bolt (D) and some have three.

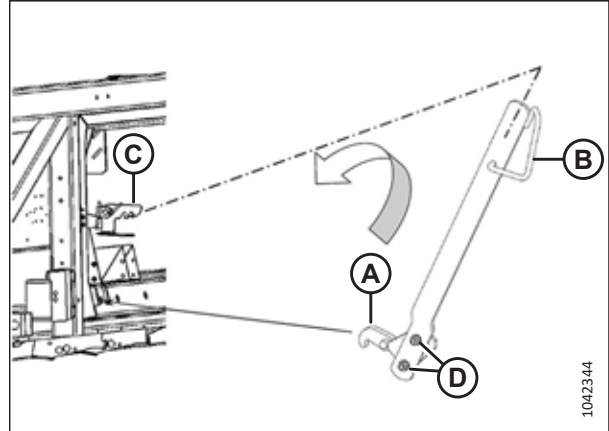

Figure 4.20: Header Latch – Case IH Flagship and Legacy, New Holland CR and CX Series

Challenger® and Massey Ferguson® 9000 Series, and Gleaner® A, N, R, and S Series

1. Check the alignment of the top mounts and the shields around the feeder house. Ensure that locks (A) in the bottom corners of the feeder house latch properly. For more information, refer to your combine operator's manual.

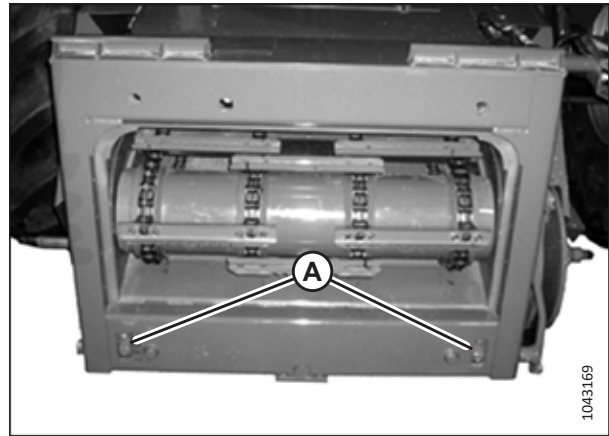

Figure 4.21: Combine Feeder House – Challenger® and Massey Ferguson® 9000 Series, and Gleaner® A, N, R, and S Series

ASSEMBLING HEADER

CLAAS Lexion 500, 600, 700, 7000, and 8000 Series

1. Locate latch axles (A) on the transition frame on the rear of the header, just below the outboard corners of the delivery opening.
2. If there is a difference between the axis line of latch axle (A) and that of the hole in the combine feeder house's clamping strap (B), set the clamping strap, then fix pivot pin (C).

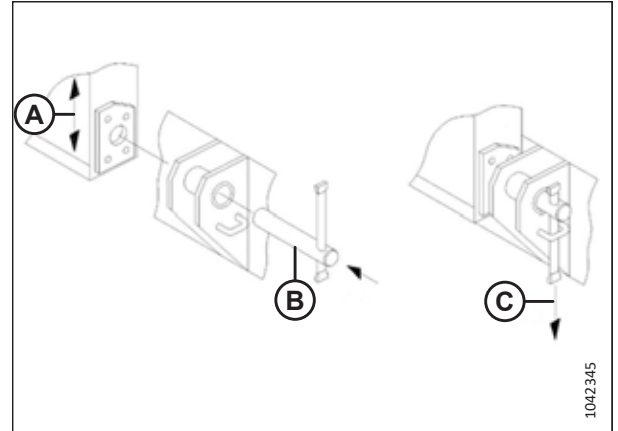

Figure 4.22: Axis Line of Latch Axle – CLAAS Lexion 500, 600, 700, 7000, and 8000 Series

IDEAL™ 7, 8, and 9 Series

1. On the header, in the bottom corners of the transition frame, loosen bolts (A), adjust them to ensure the pins on the combine feeder house go into the holes in the transition frame easily, and then retighten.

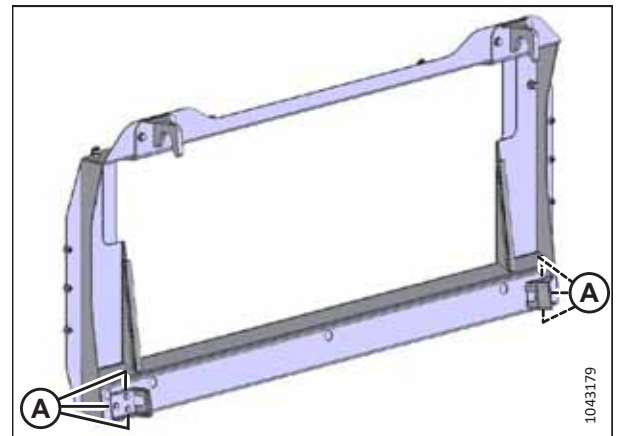

Figure 4.23: IDEAL™ Transition Frame

John Deere 60, 70, and S Series

1. On the header, in the bottom corners of the transition frame, loosen hardware (A), adjust retainer plate (B) as needed to engage the lock, and then retighten the hardware.

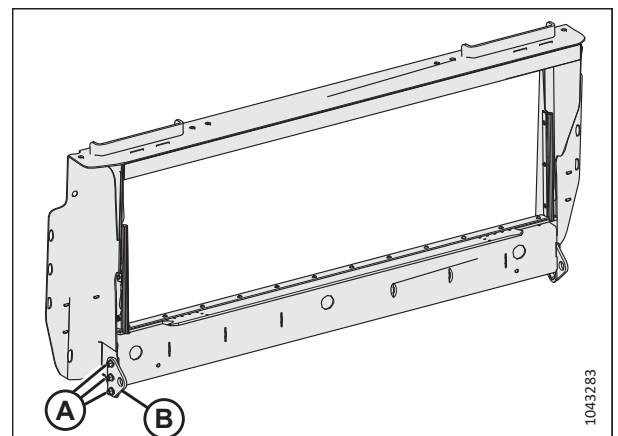

Figure 4.24: John Deere Transition Frame

ASSEMBLING HEADER

Massey Ferguson® 8500 Series

1. Adjust the nuts on U-bolts (A) as required to provide adequate clamping force. Refer to the combine operator's manual for the correct adjustments and latching methods.

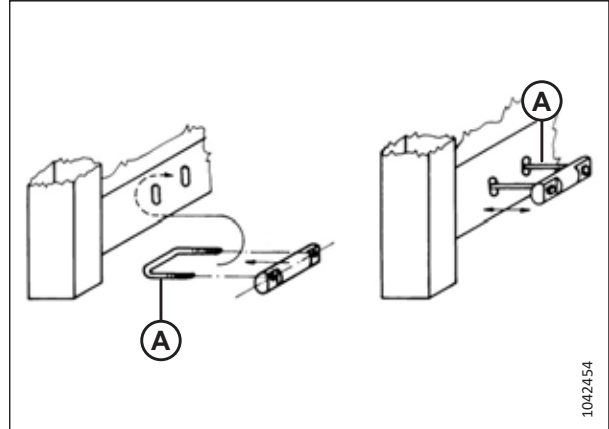

Figure 4.25: U-bolts – Massey Ferguson® 8500 Series

4.5.2 Attaching Drivelines to Combine

All headers have a driveline on the left side of the combine feeder house. Some headers also have a driveline on the right side. The driveline(s) must be connected to the combine.

1. Connect the drive shafts and ensure that the protective shields are properly in place and that all rotating parts are adequately shielded. The shafts are installed at the factory with the protective shielding supplied by the shaft manufacturer.

IMPORTANT:

After connecting to the feeder drive shaft, position protective shield (A) on the drive shaft according to the instructions in the combine operator's manual.

2. To prevent rotation of header drive shaft shield (B), attach both original chain restraints (C) to the header.

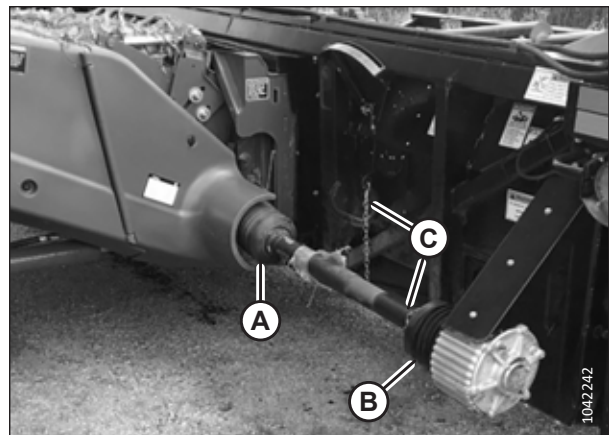

Figure 4.26: Header Driveline

4.5.3 Connecting Hydraulic and Electrical Systems

The header's hydraulic and electrical systems must be connected to the combine's hydraulic and electrical systems.

1. Connect the combine single/multi-point connector to multicoupler (A) on the left side of the header opening on the rear of the header. Refer to the combine operator's manual for the correct latching methods.

NOTE:

The connections vary for different combine brands.

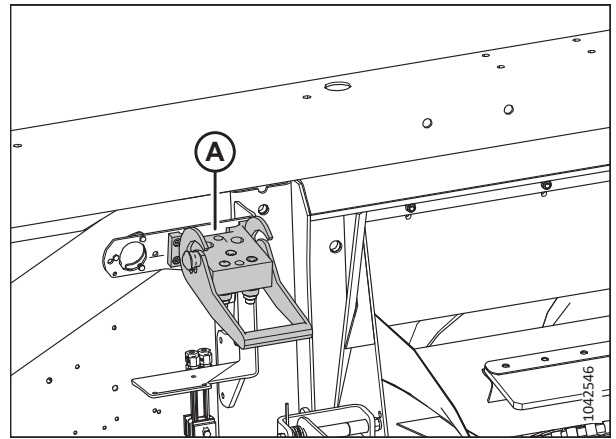

Figure 4.27: Multicoupler on a Header Configured for a Case or New Holland Combine

4.6 Removing Shipping Components

Once the header is fully assembled, the remaining shipping components need to be removed.

DANGER

Ensure that all bystanders have cleared the area.

DANGER

To prevent bodily injury or death from the unexpected start-up of the machine, always stop the engine and remove the key from the ignition before making adjustments to the machine.

1. Raise the header fully.
2. Engage the header safety props. For instructions, refer to the combine operator's manual.
3. Shut down the engine, and remove the key from the ignition.

Removing lifting bar(s)

4. Using a forklift, remove lifting bar(s) (A) from the header.

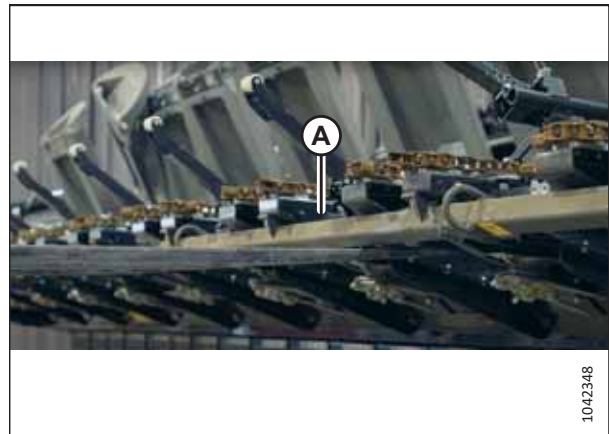

Figure 4.28: Removing Lifting Bar

ASSEMBLING HEADER

Removing folding frame lock

IMPORTANT:

The folding frame linkage **MUST** be connected before removing the folding frame locks and lowering the header to field position.

5. **Folding headers:** Remove shipping hardware (A) locking the wing to the center section.

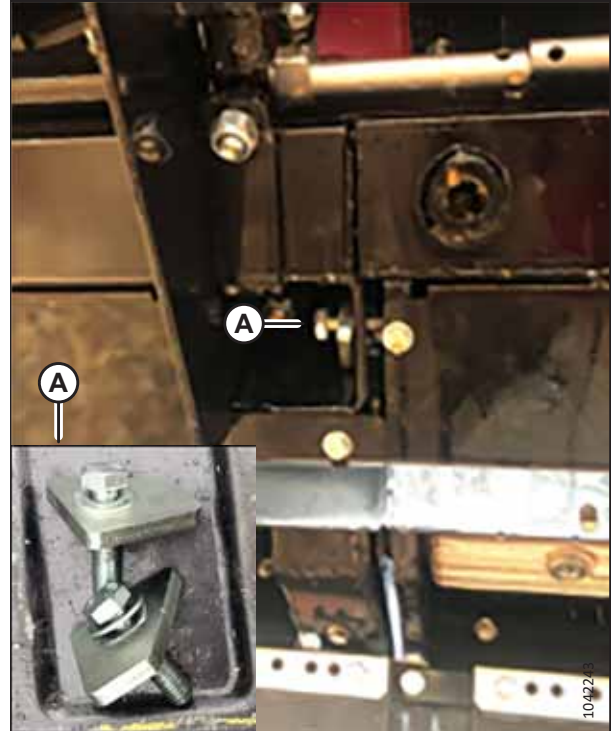

Figure 4.29: Shipping Hardware – Folding Headers

4.7 Installing End Dividers

Each header must have either standard end dividers or rotary end dividers (REDs). Tall end dividers (TEDs) can be installed on standard end dividers or REDs.

Follow the installation procedure(s) for the dividers shipped with your header:

- [4.7.1 Installing Standard End Dividers, page 36](#)
- [4.7.2 Installing Rotary End Dividers, page 37](#)
- [4.7.3 Installing Tall End Dividers, page 39](#)

4.7.1 Installing Standard End Dividers

One divider needs to be installed on each end of the header.

1. Remove the hardware securing each divider to the shipping brackets, then using a forklift or crane, remove the dividers from the header. Retain the hardware for reinstallation.
2. Remove the shipping brackets from the header.
3. Insert shaft (A) through the upper hole in each divider (B), and then secure the shaft to support (C) at the top of the header side shield with retaining plate (D) and M6 bolt (E).

NOTE:

The hardware is retained from Step 1, [page 36](#).

NOTE:

For a close-up view, refer to [Figure 4.31, page 36](#).

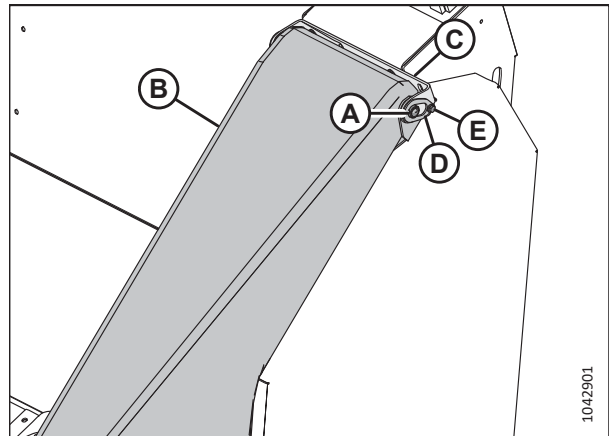

Figure 4.30: Standard End Divider Installed on Left Side Shield

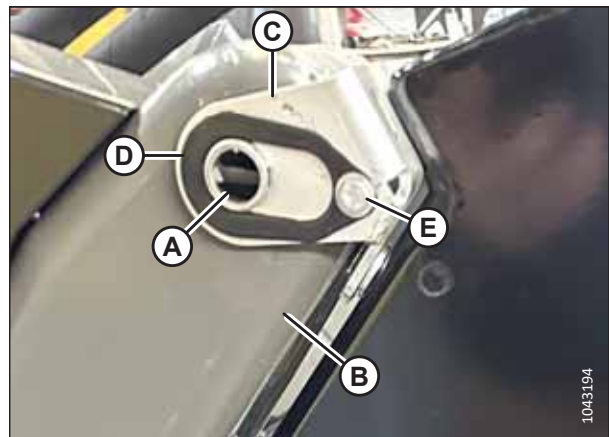

Figure 4.31: Close-Up of Top Divider Connection Point

- | | |
|-------------|---------------------|
| A - Shaft | B - Divider |
| C - Support | D - Retaining Plate |
| E - M6 Bolt | |

ASSEMBLING HEADER

4. Remove the shaft from the lower holes in divider (A), and insert it through snout (B) and then through the lower divider holes. Secure the shaft in place with two spacers (C), two spring washers (D), and two M12 x 35 Torx® hex socket button-head bolts (E). Apply medium-strength threadlocker (Loctite® 243 or equivalent) to the bolts before installing them.
5. **Headers equipped with auto header height control (AHHC):** Be sure the 8 mm spacer is installed between the divider and snout on the outboard side. Connect the front and rear wires and then secure them with a P-clip and self-tapping screw. Allow enough slack in the wires to allow the connector to move into all transport positions without contacting the gathering chains. For instructions and illustrations, refer to [4.8 Installing Snouts and Snout Height Supports](#), page 42.
6. If you are installing tall end dividers (TEDs) on the standard end dividers, proceed to [4.7.3 Installing Tall End Dividers](#), page 39, otherwise, proceed to [4.7.4 Checking and Adjusting End Divider Latches](#), page 41.

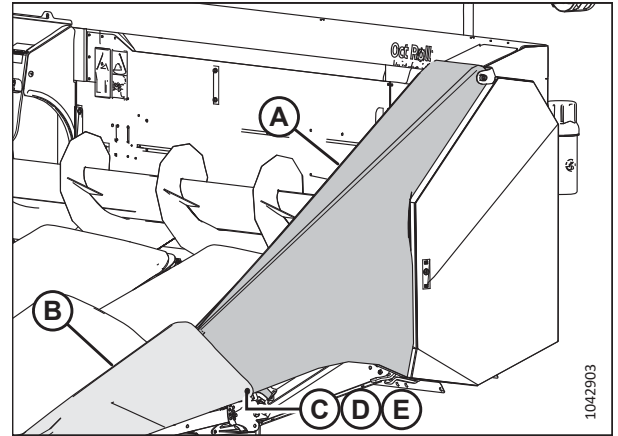

Figure 4.32: Standard End Divider Installed on Left Side Shield

4.7.2 Installing Rotary End Dividers

Rotary end dividers (REDs) are optional attachments that, if ordered, are secured to the ends of the header for shipping. One RED should be installed at each end of the header.

When ordered, two REDs are shipped with each header. Follow these steps for each of them.

1. Remove the hardware securing each RED (A) to the shipping brackets, then using a forklift or crane, remove the REDs from the header. Retain the hardware for reinstallation.
2. Remove the shipping brackets from the header.



Figure 4.33: RED in Shipping Configuration

ASSEMBLING HEADER

3. Insert shaft (A) through the upper hole in each divider (B), and then secure the shaft to support (C) at the top of the header side shield with retaining plate (D) and M6 bolt (E).

NOTE:

The hardware is retained from Step 1, page 37. One set of hardware secures each end of the shaft to the divider and support.

NOTE:

For a close-up view, refer to Figure 4.35, page 38.

4. Remove the shaft from the lower holes in the divider, and insert it through snout (F) and then through the lower divider holes. Secure the shaft in place with two spacers (G), two spring washers (H), and two M12 x 35 Torx® hex socket button-head bolts (J). Apply medium-strength threadlocker (Loctite® 243 or equivalent) to the bolts before installing them.

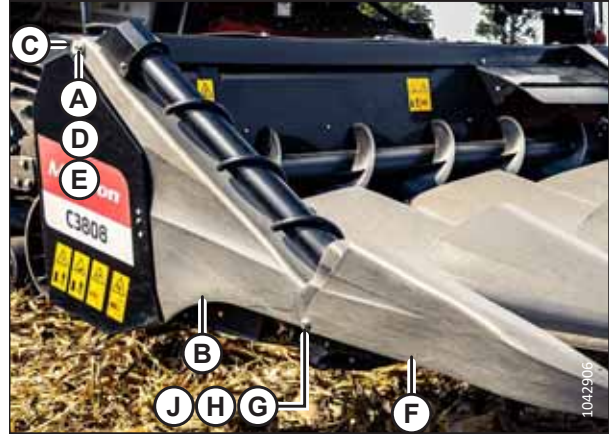

Figure 4.34: RED Installed on Header – Right Side

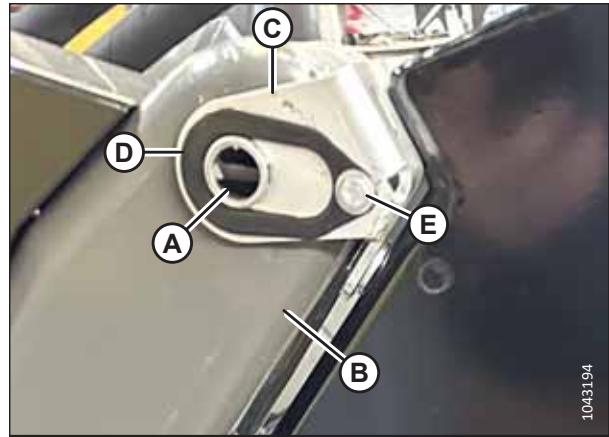

Figure 4.35: Close-Up of Top Divider Connection Point – Left Side

- | | |
|-------------|---------------------|
| A - Shaft | B - Divider |
| C - Support | D - Retaining Plate |
| E - M6 Bolt | |

ASSEMBLING HEADER

5. **Headers equipped with auto header height control (AHHC):** Be sure the 8 mm spacer is installed between the divider and snout on the outboard side. Connect the front and rear wires and then secure them with a P-clip and self-tapping screw. Allow enough slack in the wires to allow the connector to move into all transport positions without contacting the gathering chains.
6. Hydraulic hoses are routed from the motors on the REDs, along the top of the header to the multicoupler. Secure the hoses in the factory-installed hydraulic clamps (A). Pull the hoses tight before tightening the clamps.
7. If you are installing tall end dividers (TEDs) on the REDs, proceed to [4.7.3 Installing Tall End Dividers, page 39](#), otherwise, proceed to [4.7.4 Checking and Adjusting End Divider Latches, page 41](#).



Figure 4.36: RED Hydraulic Hoses

4.7.3 Installing Tall End Dividers

Tall end dividers (TEDs) can be installed on both standard end dividers and rotary end dividers (REDs). If ordered, one TED should be installed on each standard end divider or RED.

NOTE:

TEDs are secured to the bottom of the header for shipping, and should have been removed and set aside in [4.1 Preparing Header While in Standing Position, page 17](#).

Follow these steps to install each TED:

1. When installing TEDs on REDs, ensure that the reel drive hydraulics are disabled in the combine cab. For instructions, refer to the combine operator's manual.
2. Lift the front end of existing standard or rotary end divider (A) and fold attached snout (B) down into bent-knee position.
3. Remove existing locking plate (C) from the rear side of the snout (if present). Retain the hardware.
4. Position the TED on top of the snout, and secure the TED's locking plate to the rear side of the snout with the existing hardware. The rubber curtain should fall on the inboard side of the snout.

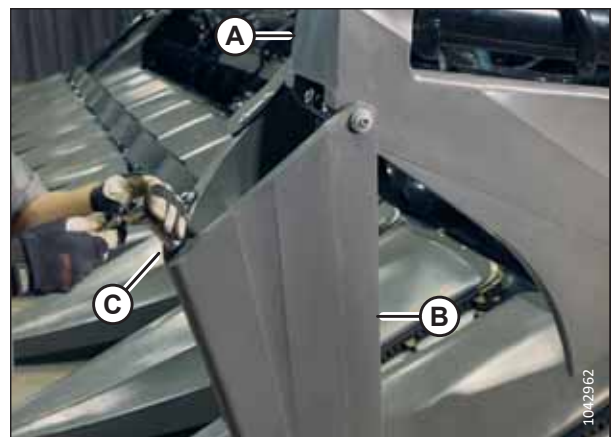

Figure 4.37: Rotary End Divider and Snout in Bent-Knee Position

ASSEMBLING HEADER

5. Insert an M8 x 100 hex bolt (A) through an M8 washer, then up through a hole near the end of the end snout into the molded nut near the tip of the TED.
6. Torque all the installed hardware to 23 Nm (204 lbf-in [17 lbf-ft]).



Figure 4.38: TED Installed on Left Standard End Divider

7. Return snout (A), standard or rotary end divider (B), and tall end divider (C) to field position as shown in the illustration at right.
8. Repeat this procedure with the second TED on the other end of the header.

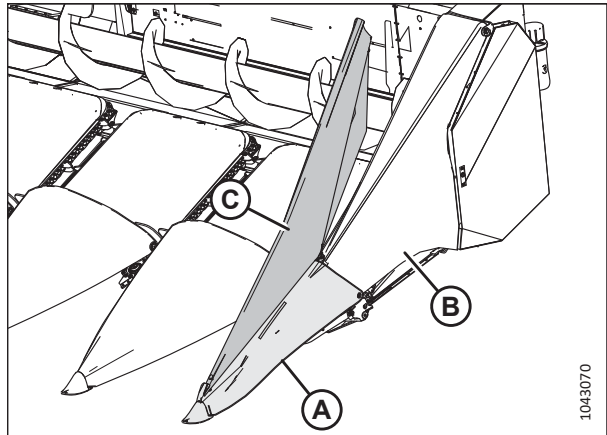

Figure 4.39: TED Installed on Left Standard End Divider

4.7.4 Checking and Adjusting End Divider Latches

Once the standard end dividers or rotary end dividers (REDs) have been installed, the latches at the front ends of the dividers need to be checked, and if necessary, adjusted.

1. Lower the end divider.
2. At the bottom/front end of the divider, check if shaft (A), securing the divider to the snout, seats into latching channel (B) as shown in the illustration at right.

NOTE:

The top of the divider and the snout have been removed from the illustration so that you can clearly see the latch mechanism.

3. If not, loosen three bolts (C) and slide channel (B) forward or rearward to allow shaft (A) to seat.
4. Tighten all bolts.
5. Swing latch (D) into place and lock it with lynch pin (E).
6. Repeat this procedure on the opposite end divider.

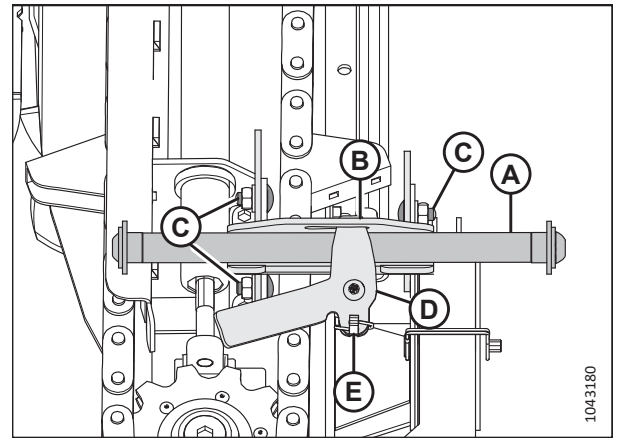

Figure 4.40: Left End Divider Latch

4.8 Installing Snouts and Snout Height Supports

Snouts must be removed from their shipping position and then reinstalled in field position.

DANGER

Ensure that all bystanders have cleared the area.

DANGER

To prevent bodily injury or death from the unexpected start-up of the machine, always stop the engine and remove the key from the ignition before making adjustments to the machine.

1. Lower the header to the ground.
2. Shut down the engine, and remove the key from the ignition.
3. Remove the snouts from their shipping position, retaining the Torx® hardware and washers securing them in place. Discard the shipping brackets.



Figure 4.41: Snouts in Shipping Position

ASSEMBLING HEADER

4. **Headers with 76 cm (30 in.) row spacing:** Remove wire bracket supports (A) from the wooden shipping crate, and install them on the front snouts. When necessary, the brackets will support the snouts in a raised position for service as shown in the illustration at right.

NOTE:

The wire bracket supports should not be used when transporting the header on the road. The snouts should be pointing down for transport as shown in Figure 4.44, page 44.

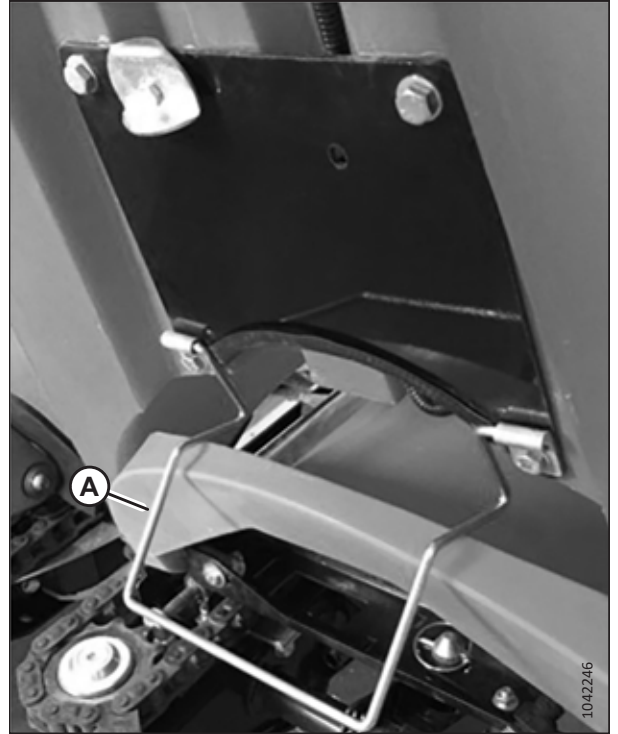

Figure 4.42: Wire Bracket Support Installed on Front Snout – Raised Service Position



Figure 4.43: Wire Bracket Support Installed on Front Snout – Field Position

ASSEMBLING HEADER

NOTE:

For trailer transport, remove the lynch pin securing rear divider (A) and lift the divider up. The snout tip will point down and sit in the hole just behind white plastic support (B).

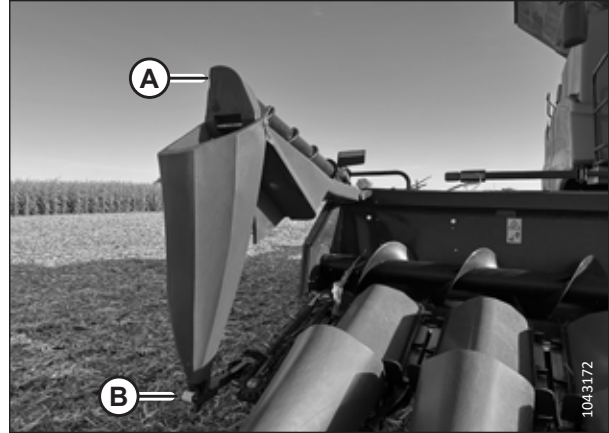

Figure 4.44: End Snout in Transport Position

5. Cross bolts (A) are positioned below snout support arms (C) for shipping purposes. One at a time, remove the cross bolts from shipping position, and reinstall them through rear second hole from the bottom (D) in fixed brackets (B) and through rear hole (E) in snout support arms (C). Secure cross bolts (A) with nuts, leaving them slightly loose to allow snout support arms (C) to pivot up and down.
6. Ensure that the nuts on the end snouts are on the side furthest from the gathering chains to avoid the ends of the bolts contacting the chains.

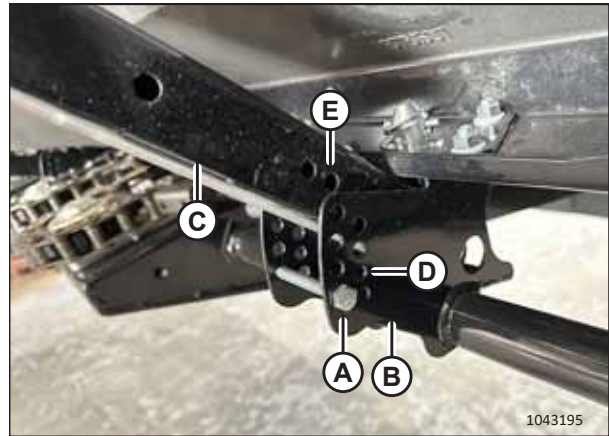

Figure 4.45: Snout Height Support in Shipping Position

7. **Headers with 50 cm (20 in.) row spacing only:** Adjust the snout position by installing bolt (A) and nut in the desired position of bracket (B).

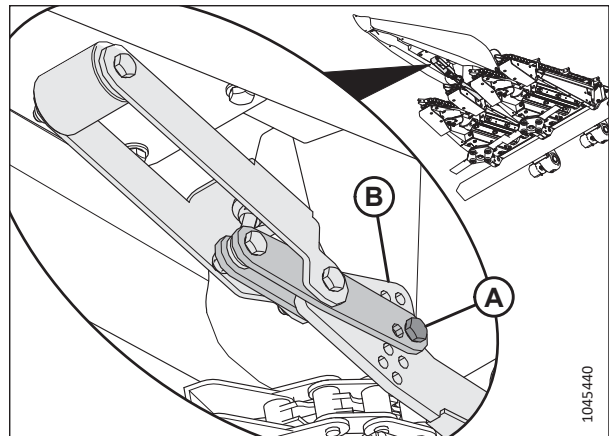

Figure 4.46: Snout Height Support

ASSEMBLING HEADER

8. Slightly loosen bolts (A) so that plastic rollers (B) are able to turn, as shown in the illustration at right. This will help prevent excess wear.

NOTE:

Do **NOT** loosen the bolts too much or the nuts will fall off.

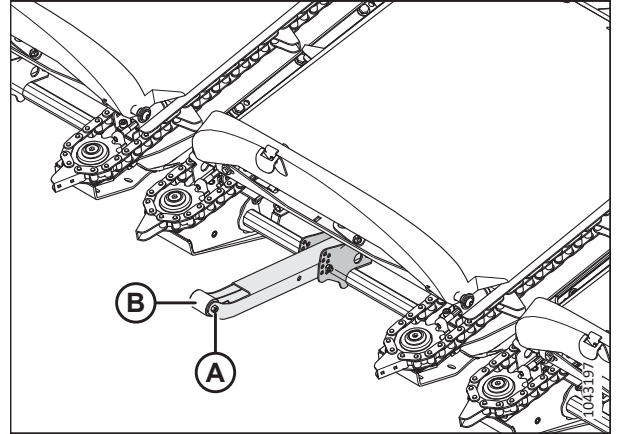

Figure 4.47: Snout Height Support

9. One at a time, position central snouts (A) on rear divider pins (B). There is one pin on each side of each rear divider.

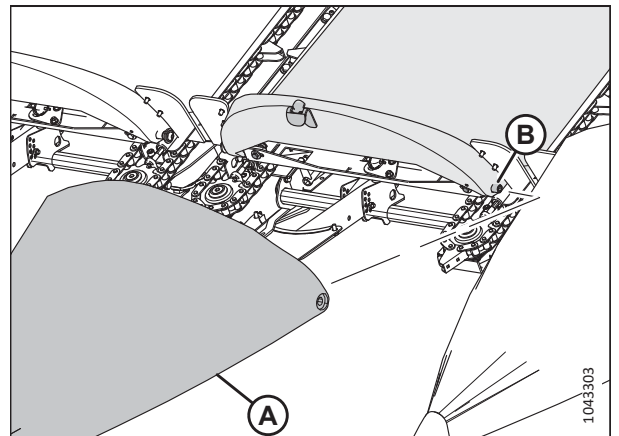

Figure 4.48: Snout Pivot Hardware

ASSEMBLING HEADER

10. **Headers equipped with auto header height control (AHHC) or row guidance:** Be sure that 8 mm spacer (A) is installed between the rear divider and snout on the left side of the header.

11. **Headers equipped with auto header height control (AHHC) or row guidance:** Connect the front electrical harness with rear harness (B), and then secure the harnesses to the divider and snout with P-clamps (C) and self-tapping screws (D). Move the snouts and dividers to ensure that there is enough slack in the harnesses to allow the snouts to move into transport position without contacting the gathering chains or binding between the snout and the dividers.

- For central divider, route cable as shown in Figure 4.49, page 46.
- For end divider, route cable as shown in Figure 4.50, page 46.

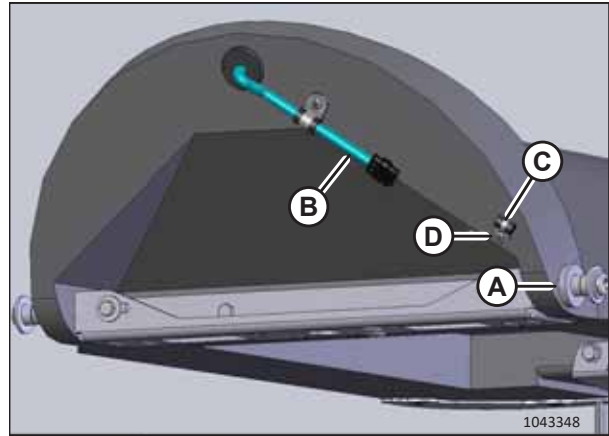

Figure 4.49: Rear Central Divider (Snout Not Shown)

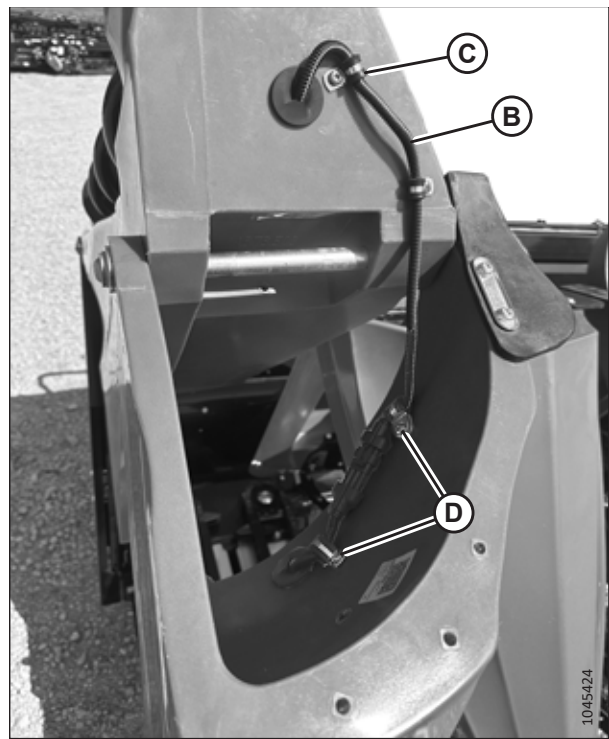

Figure 4.50: End Divider

ASSEMBLING HEADER

12. Apply medium strength threadlocker (Loctite® 243 or equivalent) to Torx® head bolts (C), and use them with washers (D) and (E) to secure each snout in place. Torque the bolts to 100 Nm (74 lbf·ft).

NOTE:

The bolts and washers were retained from Step 3, page 42.

13. If there is more than 6 mm (1/4 in.) of movement between snout (A) and rear divider (F), shift divider pins (B) inward to reduce movement. Loosen hex bolts (G) on the inboard end of the pins, slide the pins inward to achieve a tight fit, and then retighten the hex bolts.

NOTE:

Latch (H) is factory-installed on headers with 95 cm (38 in.) row spacing. It is not present on other headers.

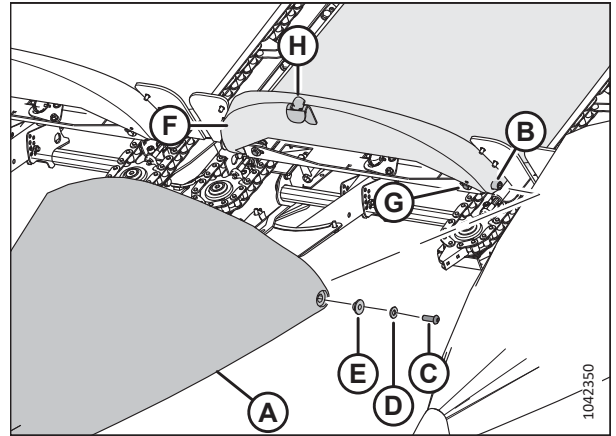

Figure 4.51: Snout Pivot Hardware

4.9 Installing Stubble Stompers (Option)

If stubble stompers were ordered with the header, they can be installed now. A maximum of two Stubble Stomper kits can be installed on C3006, C3006C, C2208, C2208C, C3008F, and C3008CF headers; a maximum of three kits can be installed on other headers. There are two stompers in each kit.

Stubble stompers can be installed in the square tubing (A) on either side of the transition frame, in the round tubes (B) holding the header stands, and in any additional round tubes (C); they cannot be installed below the combine feeder house. The number of vertical round tubes varies with the header model.

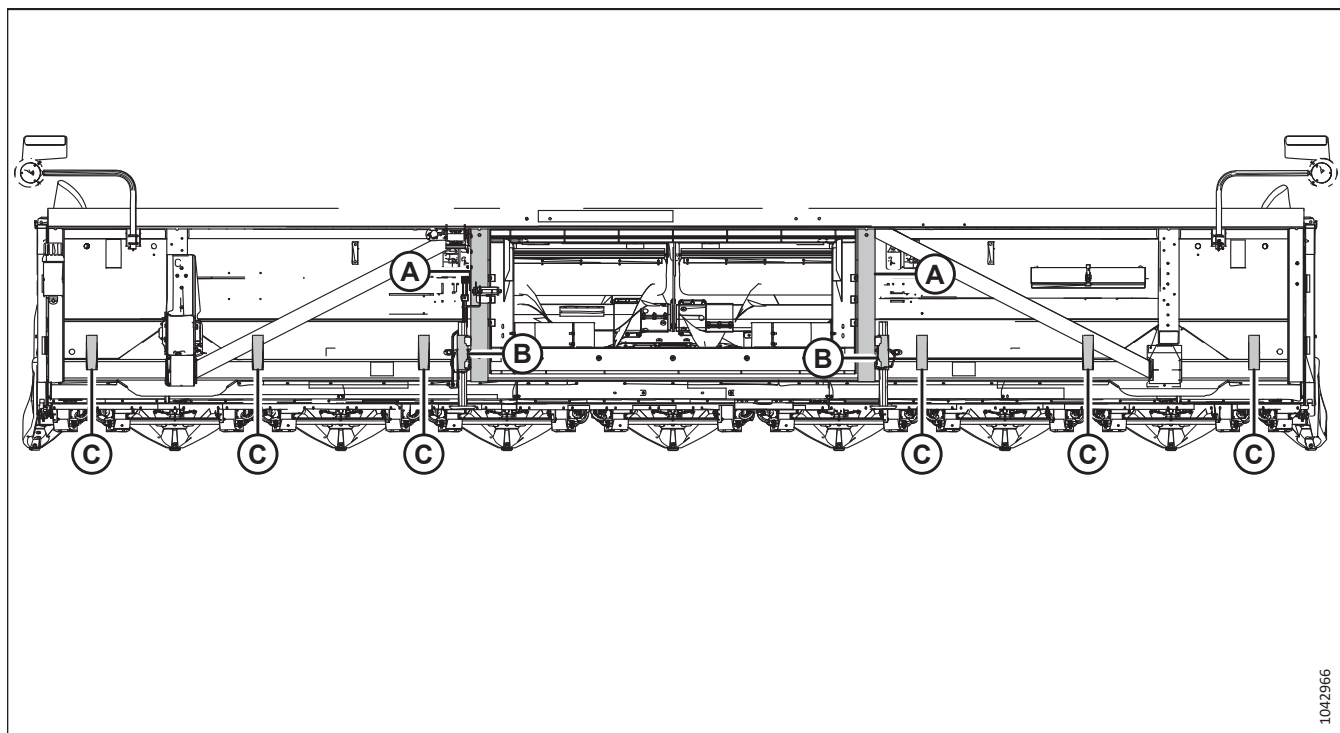

Figure 4.52: Stubble Stomper Installation Locations – C3808

To install stubble stompers, follow these steps:

1. Remove the Stubble Stomper kits from the shipping crate.
2. Identify which rows you want to stomp. If any of the rows line up with square tubing (A) on either side of the transition frame, proceed to [Step 3, page 48](#). If none of the rows line up with square tubing (A), proceed to [Step 7, page 49](#).
3. Remove any filler plugs from the bottoms of square tubing (A).

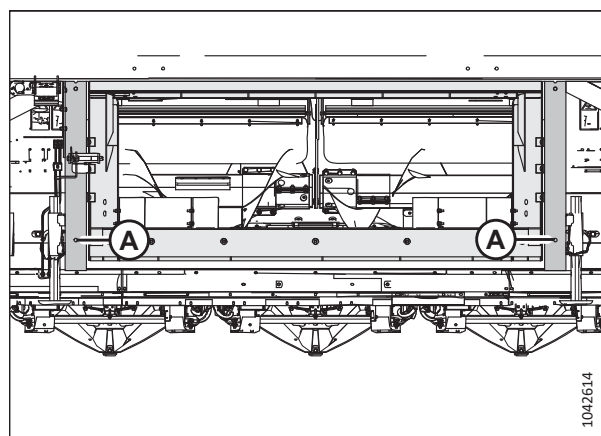

Figure 4.53: Square Tubing

ASSEMBLING HEADER

4. Remove hardware (A), (B), (C), and (D) from support (E).
5. Insert support (E) into the hole in the square tubing, and then reinstall hardware (A), (B), (C), and (D).
6. Torque M16 x 30 screw (C) to 195 Nm (144 lbf-ft) and M8 x 25 screw (A) to 23 Nm (204 lbf-in [17 lbf-ft]).

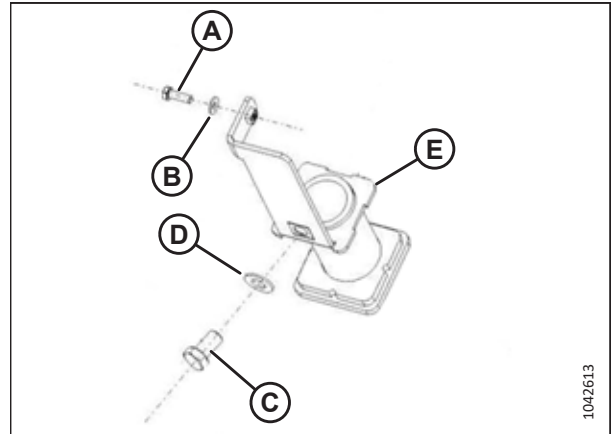

Figure 4.54: Stubble Stomper Support

NOTE:

In the illustration at right, square tubing (A) is transparent so that you can clearly see support (B) installed inside it.

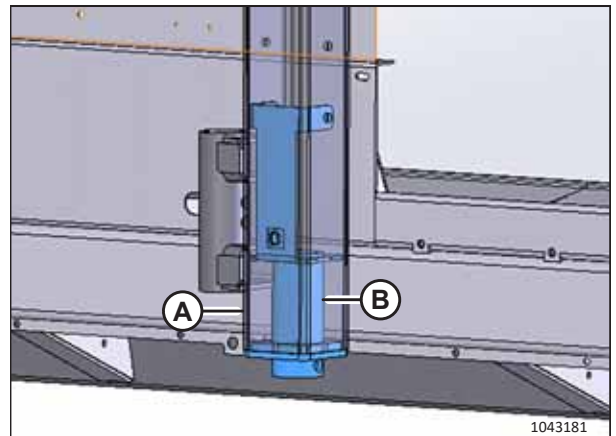

Figure 4.55: Stubble Stomper Support Installed in Square Tubing

7. If any of the rows you want to stomp line up with header stands (A), remove the stands from the round tubing in which they are installed.

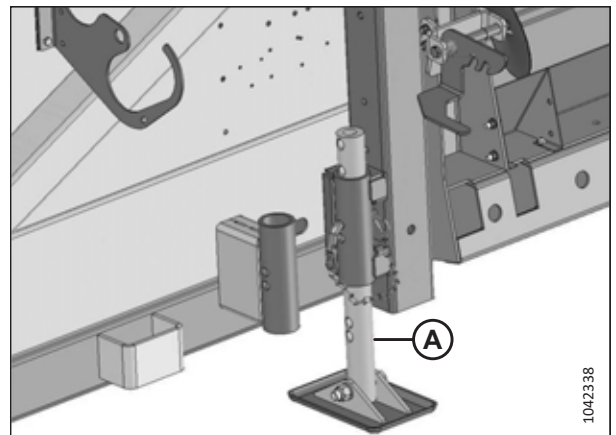

Figure 4.56: Header Stands

ASSEMBLING HEADER

8. **All stubble stomper locations:** Slide each stubble stomper shaft into the tubing until stomper (A) is at the desired height. Secure the shaft in place with pin (B) and a cotter key.

IMPORTANT:

Stubble stompers should be positioned at the highest height that will break the stalks. Operating the header with stubble stompers positioned lower than necessary can cause stomper or frame damage.

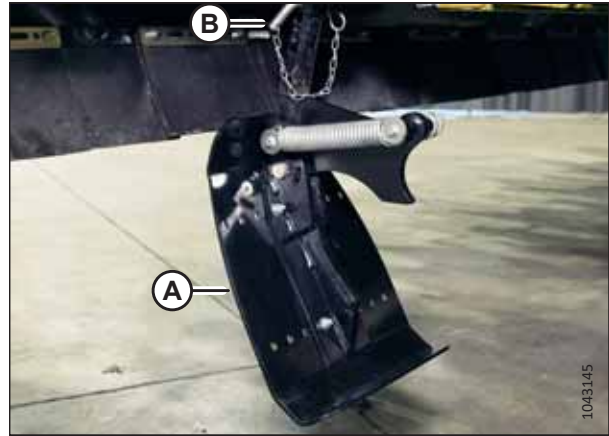

Figure 4.57: Stubble Stomper Installed

Chapter 5: Performing Predelivery Checks

Once the header has been assembled and the optional kits have been installed, the header will need to be run up and its performance tested.

IMPORTANT:

Ensure that shipping material has not fallen into the header.

Perform the final checks listed on the Predelivery Checklist (*Predelivery Checklist, page 97*) to ensure that the header is field-ready. Refer to the procedures in this chapter for detailed instructions on performing the tasks listed in the Predelivery Checklist.

The completed Predelivery Checklist should be retained by the Operator or the Dealer.

5.1 Checking and Adjusting Header Angle

The header angle must be checked, and if necessary, adjusted for field operation.

DANGER

To prevent bodily injury or death from the unexpected start-up of the machine, always stop the engine and remove the key from the ignition before making adjustments to the machine.

1. Lower the header until the front of the row unit just touches a 10 x 10 cm (4 x 4 in.) block.
2. Shut down the engine, and remove the key from the ignition.



Figure 5.1: Front of Row Unit

3. Measure snapping plate angle (A) relative to the ground and adjust the feeder house angle until 23° is achieved.

NOTE:

A snapping plate angle greater than 23° will prevent ears from feeding smoothly up the snapping unit to the auger. If feeding issues are prevalent, ensure the header angle is not greater than 23°.

NOTE:

If the header is less than 23°, watch carefully for ground contact at the choppers and rear curtain.

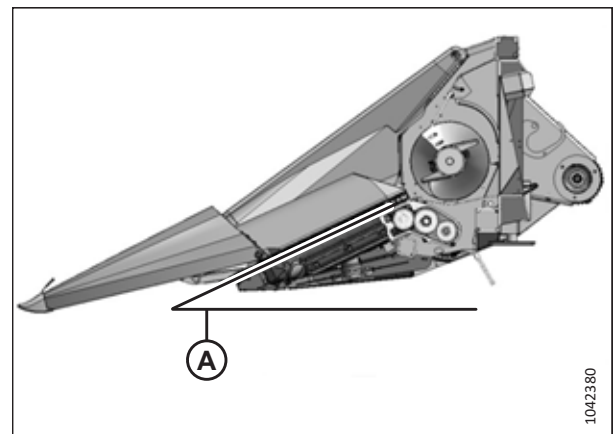

Figure 5.2: Snapping Plate Angle

5.2 Checking and Adjusting Snout Height

The snouts must be positioned properly so that they can work effectively.

1. With the header resting on 10 x 10 cm (4 x 4 in.) blocks, and the header angle set at 23°, tip (A) of each center snout should be just off the ground. Gently press each tip down. With minimal pressure, you should be able to force the tips to touch the ground.



Figure 5.3: Correct Snout Position

2. If necessary, adjust the position of each center snout as follows:
 - Make coarse adjustments by changing the position of front cross bolt (A). Ensure the support adjustment bolt head faces the gathering chain on the end snouts to avoid contact.
 - Ensure cross bolt (A) is lined up in the correct hole. The front holes on the fixed bracket should use the front holes on the arm and the rear holes on the fixed bracket should use the rear holes on the arm.
 - Ensure cross bolt (A) is slightly loose to allow snout support arm (B) to pivot up and down.
 - Fine tune the position of the snout by adjusting the rear eye bolt (C).
3. Set the end snouts 13–25 mm (1/2–1 in.) higher than the rest of the snouts to prevent them from catching crop and debris on the ground if the combine is turned while the header is on the ground.

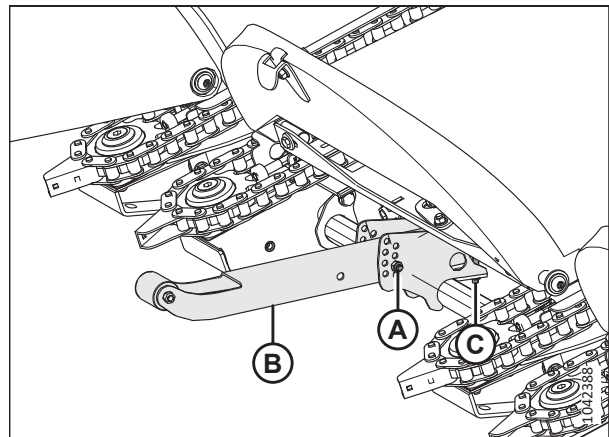

Figure 5.4: Snout Hardware – View from Below

5.3 Checking and Adjusting Snapping Plate Gap

Each row on the header has one fixed snapping plate and one moving snapping plate. Normally, the gap between the plates should measure 19 mm (3/4 in.) at the front and 24 mm (15/16 in.) at the rear. However, the gap can be adjusted when harvesting specialty crops with very large or small stalks (for example, popcorn). The gap should be 5 mm (3/16 in.) smaller at the front than at the rear to prevent plugging.

Snapping plate tool (MD #1.369.047) is helpful for this procedure, but not required.

1. Set the in-cab snapping plate adjusting mechanism to the minimum snapping plate gap.
2. Position snapping plate tool (A) (MD #1.369.047) between snapping plates (B) and (C) in the first row. The snapping plates should lightly contact the lower tabs of the snapping plate tool.

NOTE:

If the snapping plate tool is not available, measure the gap between the snapping plates using a caliper feeler gauge, or a tape measure. The gap at the front should measure 19 mm (3/4 in.) and the gap at the rear should measure 24 mm (15/16 in.).

3. If adjustment is necessary, loosen bolts (D) and adjust fixed snapping plate (C) until the tabs just fit between the snapping plates, then retighten the bolts.
4. Repeat Steps 2, [page 53](#) and 3, [page 53](#) for each of the remaining rows.

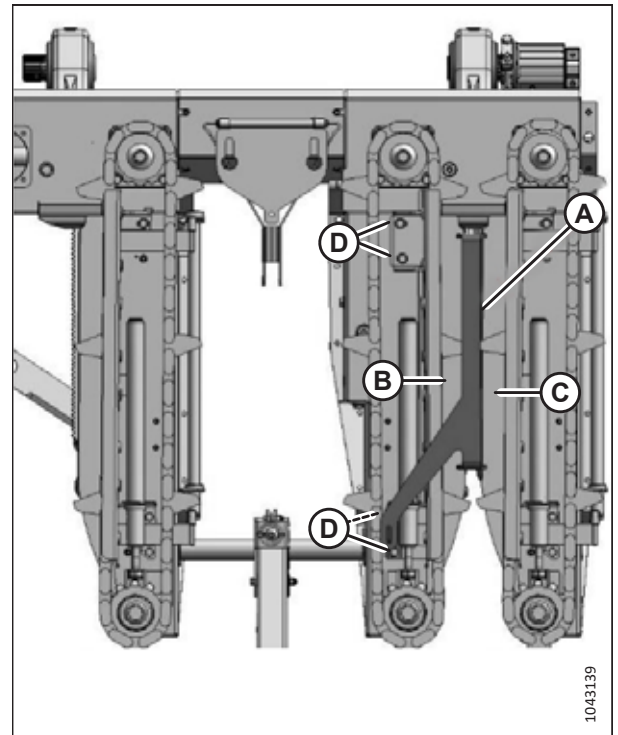

Figure 5.5: Snapping Plate Tool Positioned between Snapping Plates

5.4 Checking and Adjusting Rear Divider Latch

Rear divider latch adjustment is important for easy latching and quick turn around when transporting the header.

You may want to use snout seating tool (MD #1.369.048); it will ensure that the snouts align with the brackets after they are tightened down.

1. Raise the first center snout.
2. Remove lynch pin (A) from support pin (B).
3. Raise rear divider (C).
4. Close rear divider (C). If it latches correctly, proceed to Step 8, page 55. If it does not, proceed to Step 5, page 54.

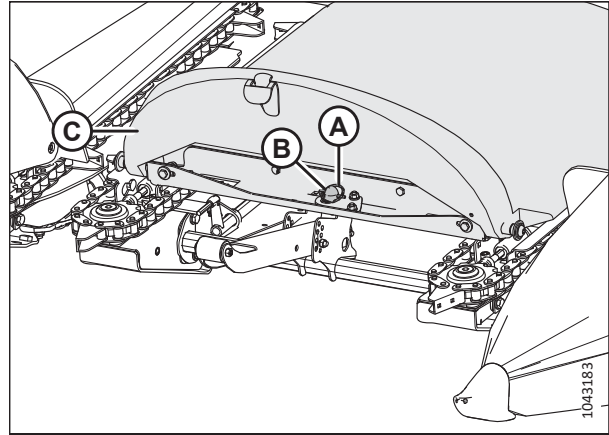

Figure 5.6: Rear Divider

5. Position the center hole in snout seating tool (A) (MD #1.369.048) over support pin (B). Slots in the tool should fit over tabs (C).

NOTE:

Different slots in the snout seating tool will be used depending on the row spacing.

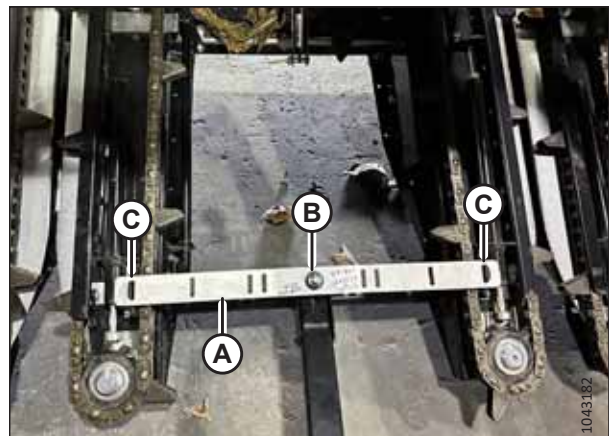

Figure 5.7: Snout Seating Tool in Use

PERFORMING PREDELIVERY CHECKS

6. If adjustment is needed, do one or both of the following:
 - Loosen socket-head screws (B), and then move tabs (C) until they are aligned. Tighten screws.
 - Loosen the nut below support pin (A), adjust the position of the support pin, and then tighten the nut.

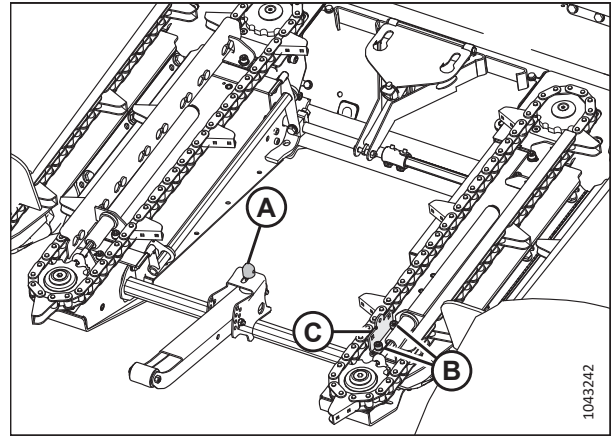

Figure 5.8: Adjustment Points

7. Lower rear divider (C), and reinstall lynch pin (A) in support pin (B).
8. Lower the snout into field position.
9. Repeat this procedure for each remaining rear divider.

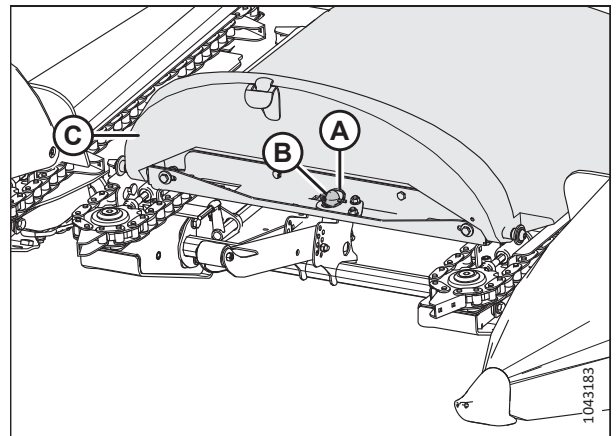

Figure 5.9: Rear Divider

5.5 Checking and Adjusting Auger Flighting Configuration

Headers come factory-configured with reverse auger flighting, which is sufficient for most conditions. If needed for challenging conditions, this flighting can be replaced with paddle flighting, which is included in the wooden shipping crate on every header.

1. Determine what kind of auger flighting (A) is appropriate for your conditions.
 - Reverse flighting – The best all round flighting option; performs well in most conditions.
 - Paddle flighting – Recommended for use in corn with very dry stalks and in high trash conditions.

NOTE:

Paddle flighting can be disassembled to expose finger flighting.

2. If necessary, remove the factory-installed reverse flighting and install paddle flighting in its place. Paddle flighting is shipped in the wooden crate.

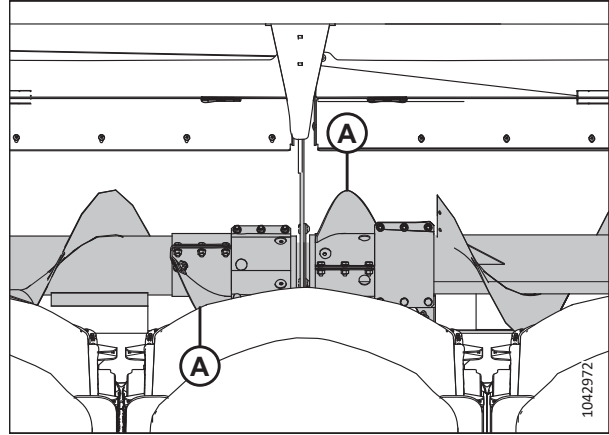

Figure 5.10: Auger with Reverse Flighting

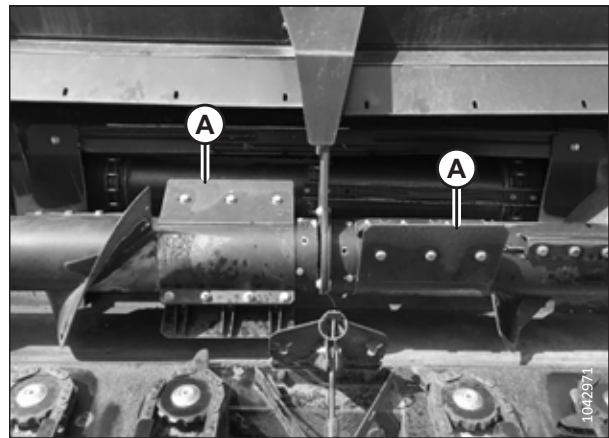

Figure 5.11: Auger with Paddle Flighting

5.6 Checking and Adjusting Auger Position

To promote ear-on-ear feeding through the auger, the auger height should be 32–38 mm (1 1/4–1 1/2 in.) on rigid headers and the clearance between the rear of the auger and the rear horizontal stripper bar should be 6 mm (1/4 in.) on all headers. The auger height is not adjustable on folding headers.

Rigid headers: You can use a 38 x 89 mm (2 x 4 in.) block of wood as a gauge when setting the auger height.



Figure 5.12: Auger Resting on Wood Block

1. **Rigid headers:** Check gap (A) between the auger flighting and auger pan as shown in the illustration at right. If the gap is less than or greater than 32–38 mm (1 1/4–1 1/2 in.), adjustment is required.

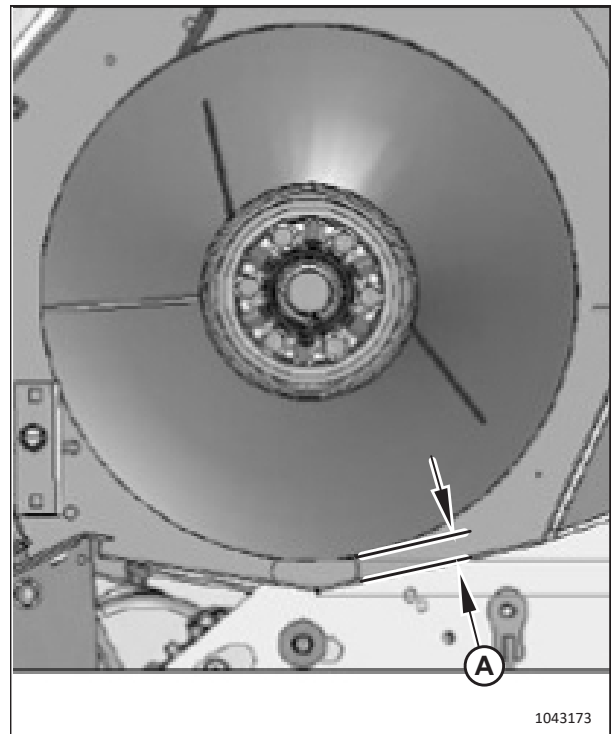

Figure 5.13: Clearance between Auger Flighting and Auger Pan

PERFORMING PREDELIVERY CHECKS

2. Check the gap between auger flighting (A) and rear horizontal stripper bar (B) as shown in the illustration at right. If the gap is less than or greater than 6 mm (1/4 in.) across the length of the auger, adjustment is required.



Figure 5.14: Auger-to-Stripper Bar Clearance

3. Open the right side shield.
4. Loosen bolts (A).
5. Loosen Torx® bolt (C) securing the tensioner pulley, and adjust draw bolt (D) to loosen the chain.
6. **Rigid headers:** To adjust the auger-to-pan clearance, slightly loosen bolt (E), then use bolt (B) to move the auger.
7. To adjust the auger-to-stripper bar clearance, slightly loosen bolt (B), then use bolt (E) to move the auger.
8. Once the auger is positioned correctly, tighten all bolts.
9. Repeat this procedure on the left side of the header.

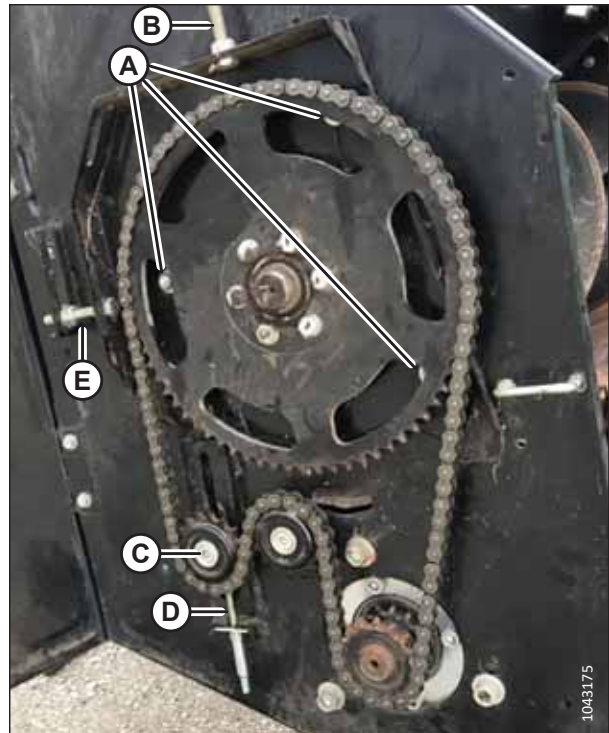

Figure 5.15: Auger Drive – Right Side

PERFORMING PREDELIVERY CHECKS

10. **Headers with two-piece augers:** Adjust the center of the auger as follows:
 - a. Support the auger so that it doesn't fall when the nuts are loosened.
 - b. Loosen the nuts on the four bolts (A) connecting the vertical piece in the center of the auger to the frame above.
 - c. Use a prybar to move the auger until the auger-to-pan and auger-to-stripper bar clearances are both correct.
 - d. Retighten the nuts and remove the auger support.

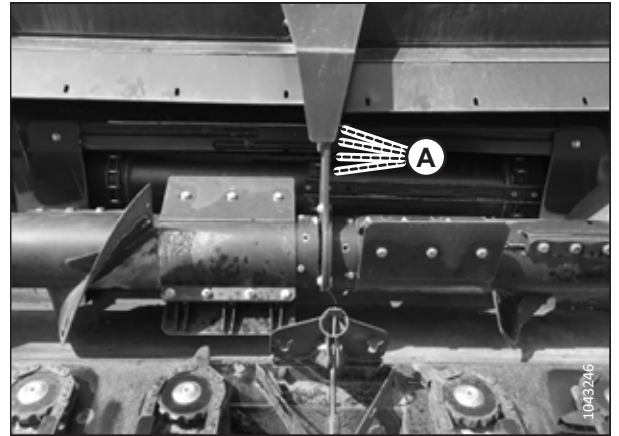

Figure 5.16: Center Auger Support Bolts

5.7 Checking and Adjusting Auger Drive Chain Tension

You will need to ensure that the auger drive chain is tensioned correctly.

NOTE:

Check chain tension after torquing the idler sprocket as tightening the sprocket can change the chain tension.

1. Check the tension of the auger drive chain. It should deflect 19 mm (3/4 in.) at location (A).
2. If the chain tension is not correct, loosen Torx® bolt (B) securing the tensioner pulley, then adjust draw bolt (C) to achieve correct chain tension. Retighten bolt (B).

NOTE:

It is better to have a loose chain than a tight one.

3. Close the side shield.

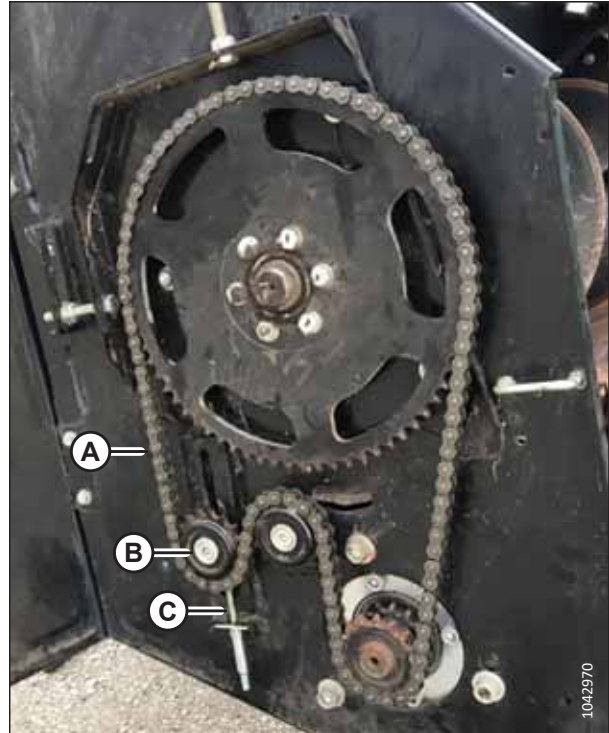

Figure 5.17: Auger Drive Chain

5.8 Checking and Adjusting Center Auger Timing – Two-Piece Augers

If there is a two-piece auger installed on the header, the auger timing must be checked, and if necessary, adjusted. Correct timing will aid in smooth feeding of crop into the feeder house.

1. Inspect flightings (A) and (B) on the right and left sides of the auger center. They should be offset from each other by 90° as shown in the illustration at right.
2. If the flightings are not correctly offset, follow these steps:
 - a. Disconnect the driveline(s) from the combine.
 - b. Hand-turn the chopper assembly (if equipped) or use a 32 mm wrench to turn the input hex shaft until the flightings are offset from each other by 90°.
 - c. Reconnect the driveline(s) to the combine.

NOTE:

Alternatively, loosen the auger drive chain (for instructions, refer to [5.7 Checking and Adjusting Auger Drive Chain Tension, page 60](#)), remove the chain, rotate the auger to the desired position, and then reinstall and tension the chain.

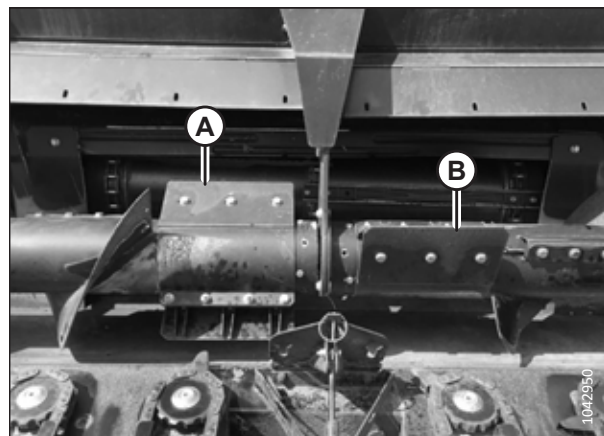

Figure 5.18: Two-Section Auger with Paddle Flighting

5.9 Checking and Adjusting Auger Debris Shield Angle

Auger debris shield(s) are installed in front of the delivery opening, above the auger. Headers with a one-piece auger have a single auger debris shield. Headers with two-piece augers have two auger debris shields.



Figure 5.19: Auger Debris Shield

1. Check the angle of the auger debris shield(s). Auger flap (A) should be 51 mm (2 in.) above the auger.
2. If the angle of the auger debris shield(s) needs to be adjusted, loosen bolts (B) on the sides of the shield(s), adjust the shield(s) to the correct angle, and then retighten the bolts.

NOTE:

Only one of bolt (B) is visible in the illustration. The second one is hidden behind the auger debris shield.

5.10 Checking and Adjusting Auger Timing – Folding Headers

On folding headers, the distance between the auger flightings should be properly maintained to optimize feeding across the wing joint. The distance between the flightings should be 457–508 mm (18–20 in.).

NOTE:

This procedure does not apply to rigid headers.

1. With the wing engaging the center section, check distance (A) between the auger flightings. Be sure to measure the distance across the support and not right at the end of the flighting.

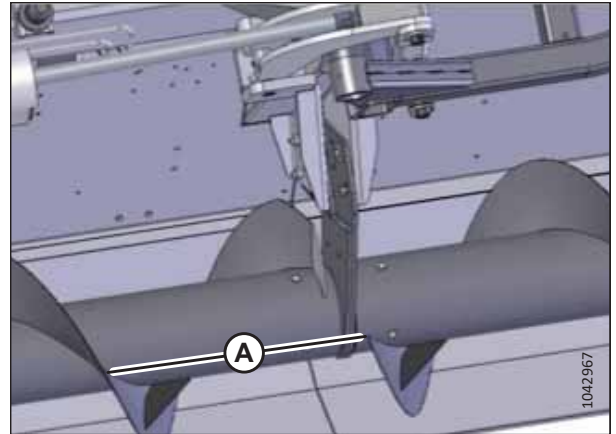
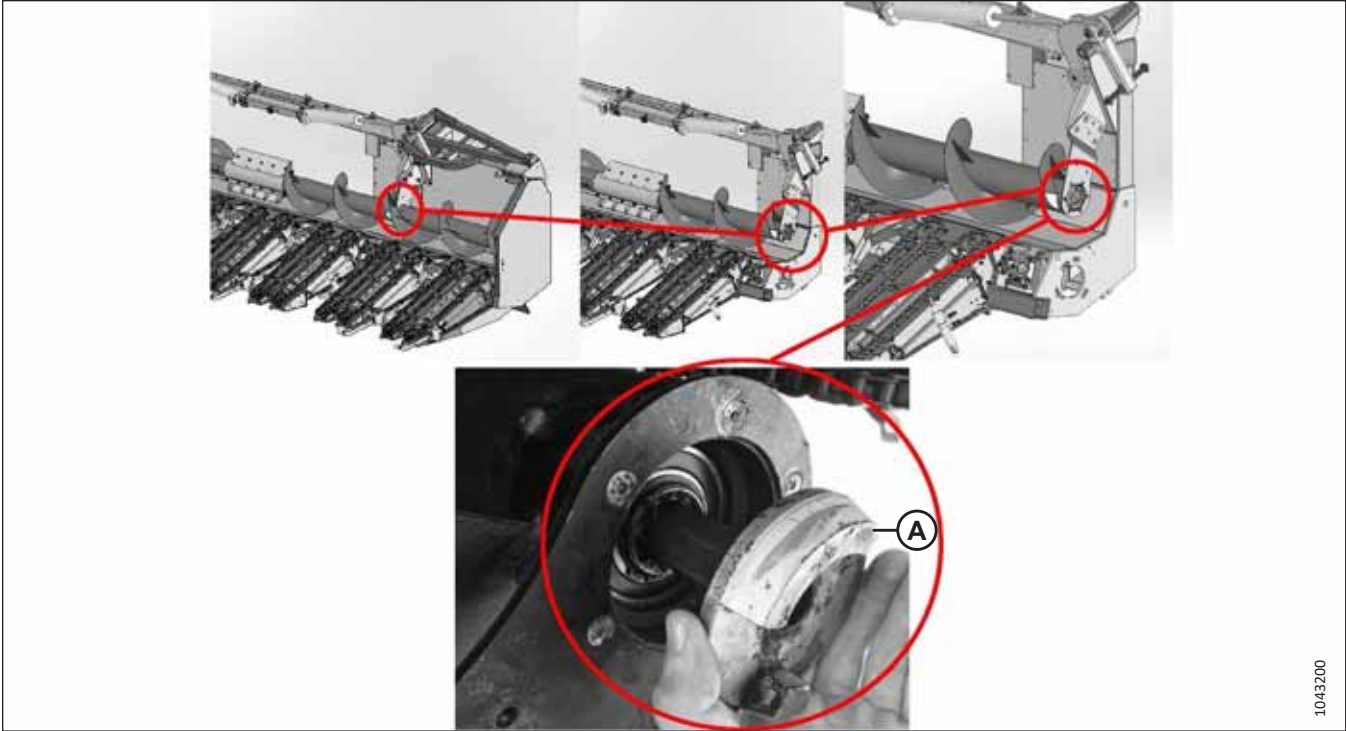

Figure 5.20: Auger Flighting

PERFORMING PREDELIVERY CHECKS



1043200

Figure 5.21: Jaw Coupler

2. If the distance is not 457–508 mm (18–20 in.), adjust as follows:
 - a. Remove the bolt from jaw coupler (A).
 - b. Remove the jaw coupler from the header.
 - c. Rotate the jaw coupler (hex shaft in hex hole).
 - d. Reinstall the jaw coupler in the header.
 - e. Reinstall the bolt in the jaw coupler.

5.11 Checking and Adjusting Fluid Levels

Fluid levels must be checked, and if necessary adjusted, in the input gearboxes, snapping unit gearbox, and if installed, the stalk chopper gearbox.

5.11.1 Checking and Adjusting Oil Level – Input Gearboxes

Depending on their configuration, headers may have one or two driver and driven input gearboxes. The oil level in each one should be checked with the header at harvesting height; the oil level changes significantly as the header is raised.

For oil type and quantity, refer to the inside back cover of this document.

1. With the header resting on 10 x 10 cm (4 x 4 in.) blocks and the header angle at 23°, remove level plug (A) from the input driver gearbox. Oil should just drip out.

NOTE:

Breather (B) should always be mounted on the top of the gearbox as shown.

NOTE:

On headers configured for CLAAS combines, the input driver gearbox is positioned higher up.

2. If the oil level is low, add oil through breather (B) or level plug (A).



Figure 5.22: Input Driver Gearbox

3. Repeat this procedure on the input driven gearbox.

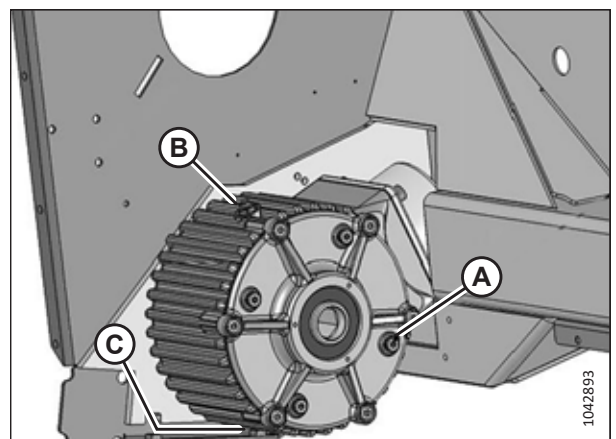

Figure 5.23: Input Driven Gearbox

A - Level Plug B - Breather
C - Drain Plug

5.11.2 Checking and Adjusting Lubricant Level – Snapping Unit Gearbox

There is one gearbox in each snapping unit. The lubricant level in each one needs to be checked, and if necessary, adjusted. For lubricant type and quantity, refer to the inside back cover of this document.

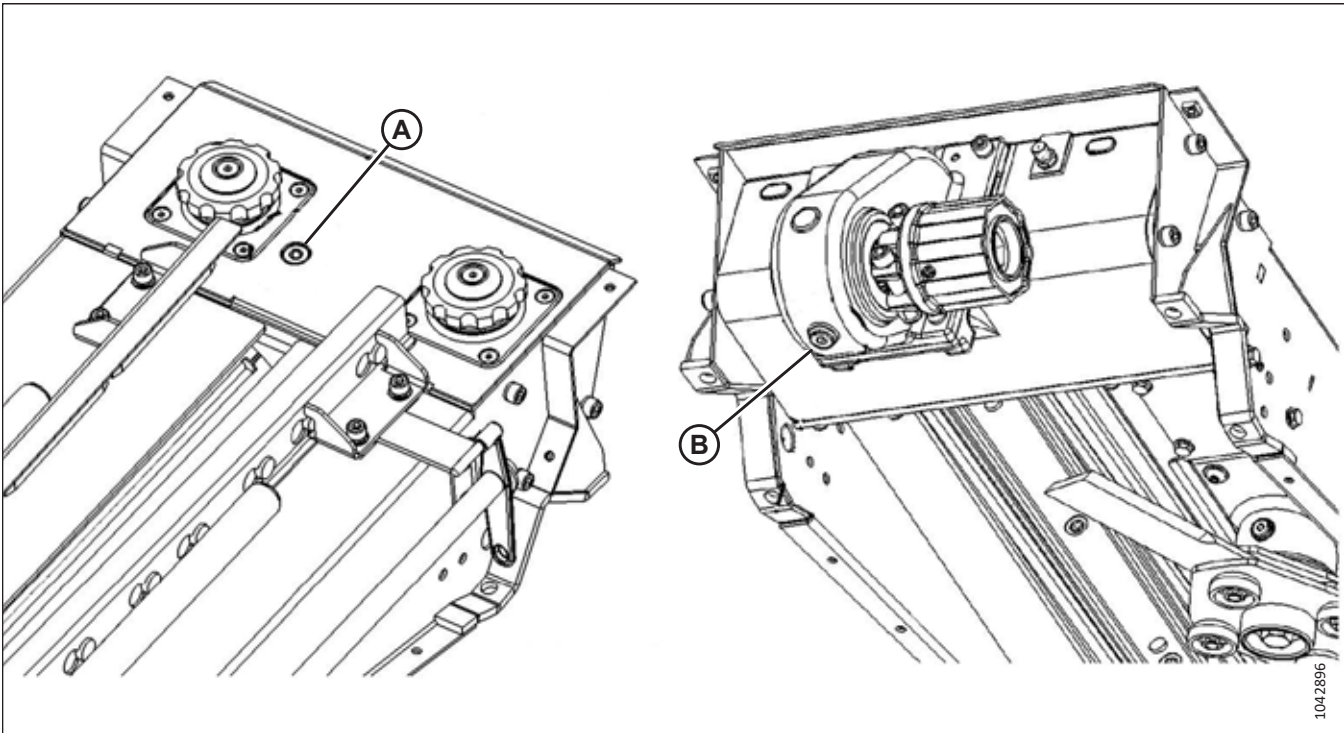

Figure 5.24: Snapping Unit Gearbox

A - Lubricant Fill Plug and Dipstick

B - Lubricant Drain Plug

1. With the header resting on 10 x 10 cm (4 x 4 in.) blocks and the header angle at 23°, inspect the first snapping unit gearbox. Unscrew dipstick (A), wipe the dipstick, then replace but do not screw it back in, wait, then remove the dipstick again. The lubricant level should be midway between the minimum and maximum warning lines.
2. If there isn't enough lubricant, add more.
3. Repeat this procedure for each of the snapping unit gearboxes.

5.11.3 Checking and Adjusting Oil Level – Stalk Chopper Gearbox (Option)

If stalk choppers are installed on the header, each one will have a gearbox. The oil level in each gearbox needs to be checked, and if necessary, adjusted.

For oil type and quantity, refer to the inside back cover of this document.

1. With the header resting on 10 x 10 cm (4 x 4 in.) blocks and the header angle at 23°, unscrew dipstick (A), wipe the dipstick, then replace but do not screw it back in, wait, then remove the dipstick again.
2. If there isn't enough lubricant, add more.
3. Repeat this procedure for each stalk chopper gearbox.

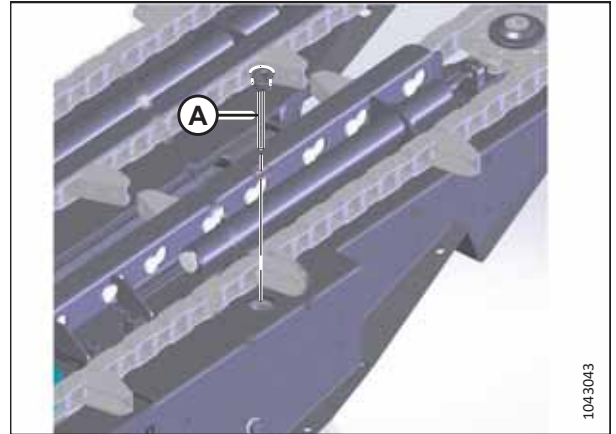

Figure 5.25: Stalk Chopper Gearbox Dipstick

5.12 Lubricating Header

All of the lubrication points on the header need to be inspected to ensure that they can accept grease.

Use the proper lubricant for the application. Refer to the table below for information on the type of lubricant to use.

Lubricant	Specification	Description	Use	Capacities
Grease	SAE multi-purpose	High temperature extreme pressure (EP) performance with 1% max. molybdenum disulphide (NLGI Grade 2) lithium base	As required unless otherwise specified	—
		High temperature extreme pressure (EP) performance with 10% max. molybdenum disulphide (NLGI Grade 2) lithium base	Header drive shaft	—
Semi-fluid grease	EP-00	Extreme pressure (EP) performance with lithium base	Row unit main gearbox	2.5 liters (2.6 quarts)
Gear lubricant	SAE 80W-140 or SAE 85W-140	API service class GL-5	Stalk chopper gearbox	0.3 liters (0.3 quarts)
			Input drive and driven gearboxes	0.9 liters (1.0 quarts)
Chain lubricant	Chain lubricant or SAE 30W oil	Chain oil is formulated to provide good wear protection and resistance to foaming. It protects the chain and drive sprockets against wear.	Auger drive chain, hex shaft chain couplings, and snapping plate indicator chain	—

5.12.1 Greasing Procedure

Some header components need to be lubricated in order to perform their function correctly and prevent machine damage.

DANGER

To prevent injury or death from the unexpected start-up of the machine, always stop the engine and remove the key from the ignition before leaving the operator's seat for any reason.

1. Wipe the grease fitting with a clean cloth before greasing it to avoid injecting dirt and grit.

IMPORTANT:

Use clean, high-temperature, extreme-pressure grease only.

2. Leave the excess grease on the fitting to keep the dirt out.
3. Replace any loose or broken grease fittings immediately.
4. Remove and thoroughly clean any fitting that will not take grease. Clean the lubricant passageway. Replace the fitting if necessary.

PERFORMING PREDELIVERY CHECKS

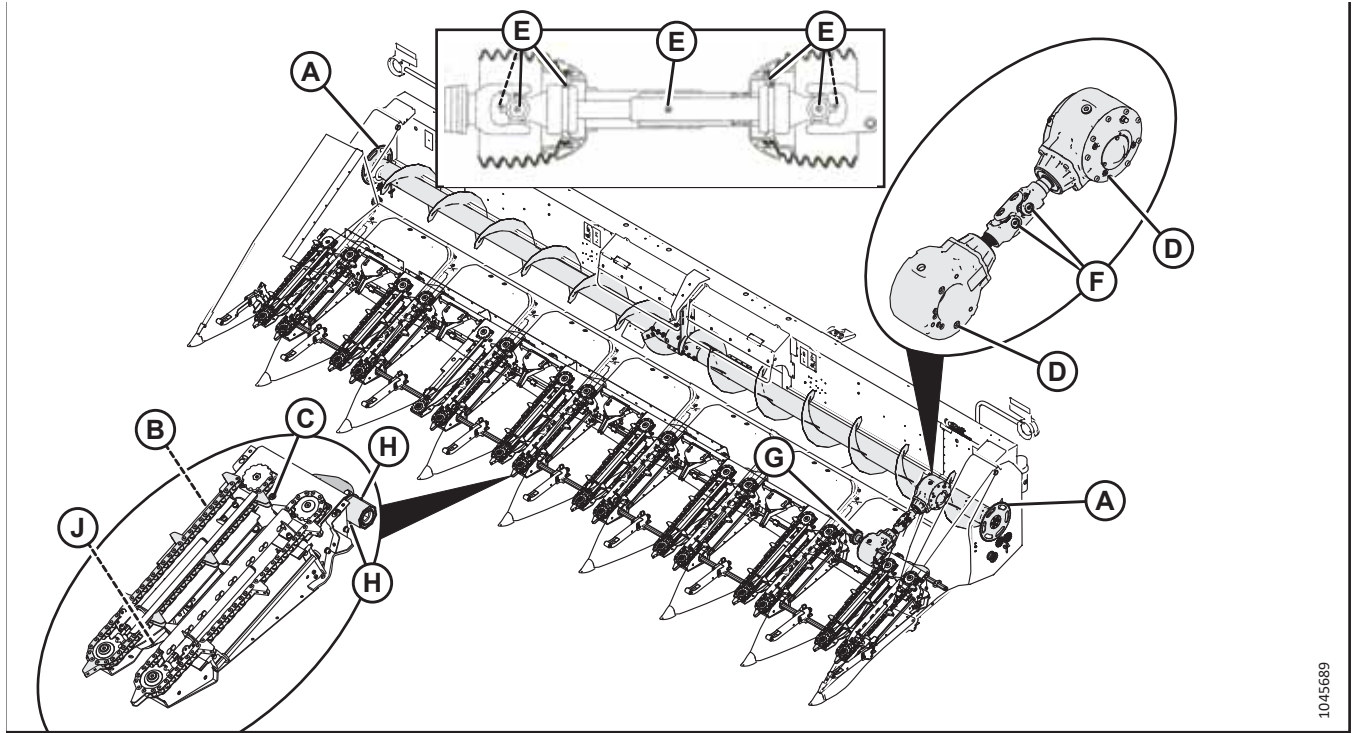

Figure 5.26: Lubrication Points

Table 5.1 Lubrication Table

Callout	Description	Lubrication Type	Interval
A	Auger drive chains (1 per side)	Chain lubricant or SAE 30W	Lubricate every 50 hours
B	Stalk chopper gearbox oil level (1 per row), if equipped	0.3 liters (0.3 quarts) SAE 80W-140 or SAE 85W-140	Replace after first 50 hours and then replace every 250 hours/annually
C	Row unit grease level (1 per row)	Semi-fluid grease – 2.5L of EP-00	Check every 50 hours
D	Input gearbox(s) (header drive) oil level (2 or 4 per header)	0.9 liters (1.0 quarts) SAE 80W-140 or SAE 85W-140	Replace after first 50 hours and then replace every 250 hours/annually
E	Header drive shaft (1 or 2 per header, 5 places each)	SAE multi-purpose grease ⁵ IMPORTANT: Two pumps only; do NOT over-grease.	Grease 100 hours
F	Input gearbox coupling shaft (1 or 2 per header, 2 places each)	SAE multi-purpose grease ⁵ IMPORTANT: Two pumps only; do NOT over-grease.	Grease 250 hours/annually
G	Hex shaft chain couplings	Chain lubricant or SAE 30W	Lubricate 250 hours/annually

5. High temperature extreme pressure (EP) performance with 10% max. molybdenum disulphide (NLGI Grade 2) lithium base

PERFORMING PREDELIVERY CHECKS

Table 5.1 Lubrication Table (continued)

Callout	Description	Lubrication Type	Interval
H	Slip clutches (2 per row)	SAE multi-purpose grease ⁶ IMPORTANT: Two pumps only; do NOT over-grease.	Grease 250 hours/annually
J	Front grease fittings on snapping rolls (1 per row)	SAE multi-purpose grease ⁶	Grease 100 hours

6. High-temperature extreme pressure (EP) performance with 1% max. molybdenum disulphide (NLGI Grade 2) lithium base

PERFORMING PREDELIVERY CHECKS

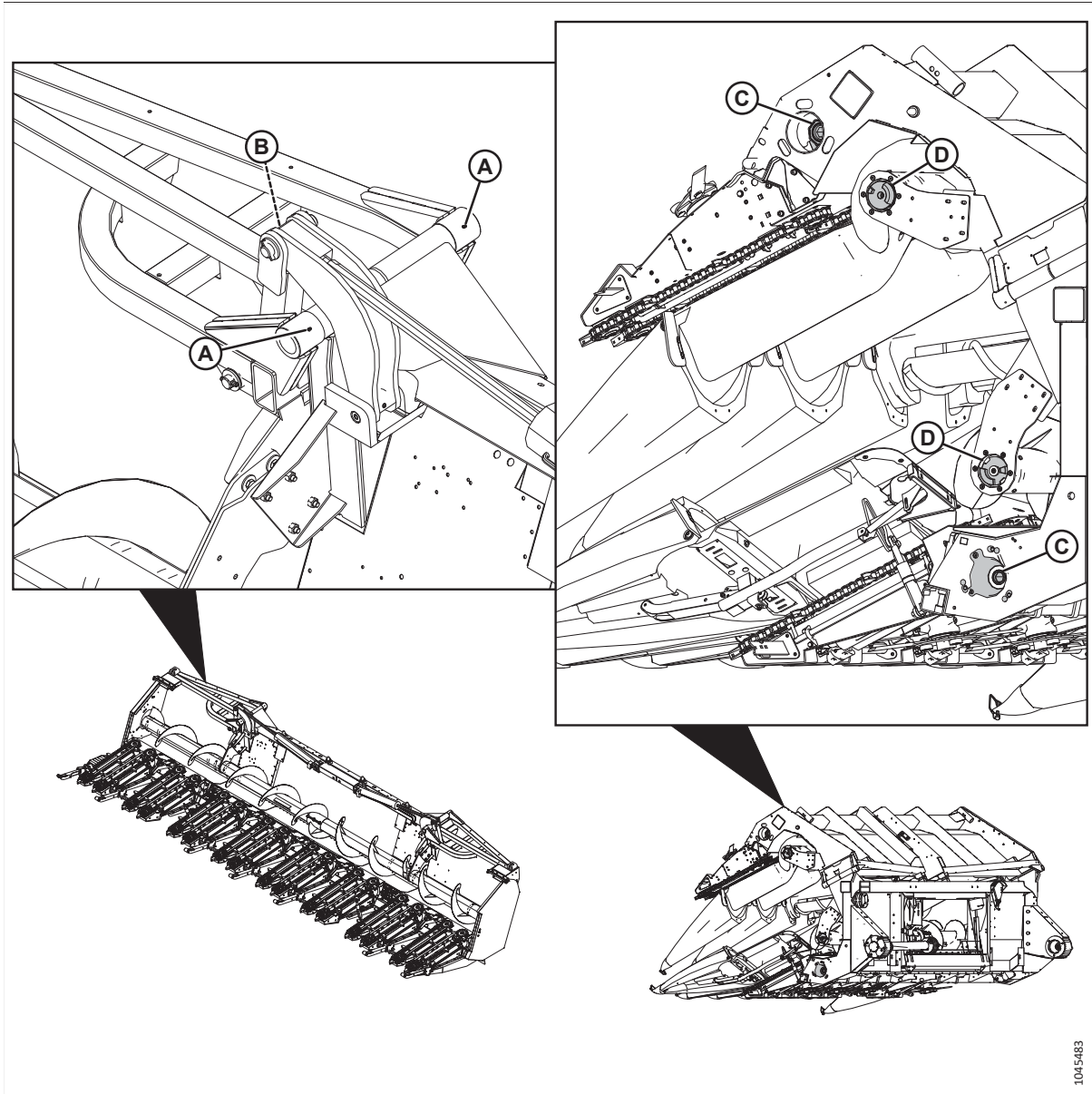

Figure 5.27: Folding Header Lubrication Points

Table 5.2 Lubrication Table – Folding Models Only

Callout	Description	Lubrication Type	Interval
A	Folding mechanism bushing – 2 per side	SAE multi-purpose grease ⁶	250 hours/annually
B	Cylinder rod end – 1 location per side	SAE multi-purpose grease ⁶	250 hours/annually
C	Snapping unit connecting clutches – 2 per side	SAE multi-purpose grease ⁶	50 hours
D	Auger connecting clutch faces – 2 per side	SAE multi-purpose grease ⁶	50 hours

Chapter 6: Configuring Combine

If rotary end dividers (REDs), an auto header height control (AHHC) system, or row guidance have been installed, the combine that will be used to operate the header will need to be configured to use them.

Refer to the appropriate instructions for your combine brand:

- [6.3 Configuring Case IH Combines, page 75](#)
- [6.4 Configuring Challenger®, Gleaner®, and Massey Ferguson® Combines, page 77](#)
- [6.5 Configuring CLAAS Combines, page 78](#)
- [6.6 Configuring IDEAL™ Combines, page 79](#)
- [6.7 Configuring John Deere Combines, page 80](#)
- [6.8 Configuring New Holland Combines, page 81](#)

6.1 Recommended Sensor Output Voltages for Combines

The auto header height control (AHHC) sensor output must be within a specific voltage range for each combine, or the AHHC feature will not work properly. The recommended lower and upper voltage values for best AHHC operation are provided.

Table 6.1 Combine Voltage Limits

Combine	Lower Voltage Limit (V)	Upper Voltage Limit (V)	Minimum Range (V)
All combine models except New Holland 10 V models	0.7	4.3	2.5
New Holland 10 V combines	2.8	7.2	4.1–4.4

NOTE:

Some combine models do not support checking sensor output voltage from the cab (e.g., early Case, and CLAAS 500/600/700 Series). For these models, check output voltage manually.

6.2 Adjusting Auto Header Height Sensor Voltage

C Series Corn Headers equipped with the optional two-sensor auto header height control (AHHC) system have sensors located on the two end snouts. Headers equipped with the optional three-sensor system have an additional sensor located on the center snout.

DANGER

To prevent injury or death from the unexpected start-up or fall of a raised machine, always stop the engine and remove the key from the ignition before leaving the operator's seat or making adjustments to the machine. Never work on or beneath an unsupported header. If the header is fully raised, always engage the safety props. If the header is off of the ground but not raised to its full height, place blocks under the header.

NOTE:

Two-sensor systems should be installed on headers configured for CLAAS, or AGCO combine brands. The three-sensor systems should be installed on headers configured for Case, New Holland, or John Deere combines.

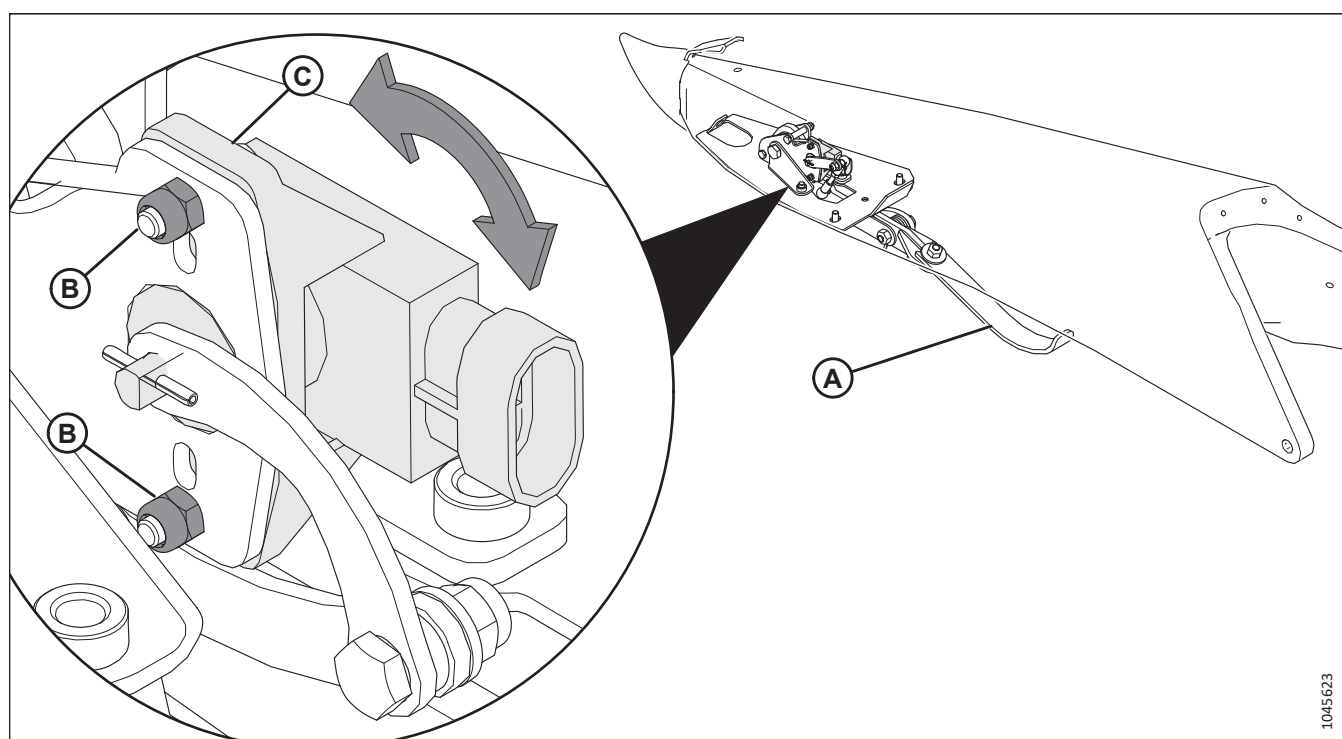

Figure 6.1: AHHC Sensor Inside End Snout

1. To check the sensor's output voltage range, open the diagnostics page in the combine monitor to view the voltage seen on each sensor, and then manually cycle the AHHC arm (A) through the entire range.

NOTE:

Some combines are not equipped to display the AHHC sensor voltage.

2. Ensure the sensor voltage is within the lower and upper limits. Refer to [6.1 Recommended Sensor Output Voltages for Combines, page 73](#).
3. If the voltage is outside of the ideal range, loosen nuts (B) and rotate sensor body (C) to adjust the voltage limits.
4. When adjustment is complete, torque nuts (B) to 3 Nm (2.2 lbf-ft [22 lbf-in]).
5. Repeat all the steps on the other sensors.

6.3 Configuring Case IH Combines

Case IH combines can be configured to use rotary end dividers (REDs) and auto header height control (AHHC) if necessary.

Setting up REDs

1. On the combine display, navigate to the HEADER SETUP 1 page.
2. From DECK PLATES menu (A) and HYDRAULIC ROTATING DIVIDERS menu (B), select INSTALLED. The speed of the REDs is controlled the same as the reel speed would be controlled on a platform header.
3. **Folding headers:** from the FRAME TYPE pull-down menu (C), select FOLDING.



Figure 6.2: Case IH Combine Display – Header Setup 1 Page

Configuring AHHC

4. Follow the instructions on the combine display to configure the AHHC. For assistance, refer to the combine operator’s manual.
5. Follow the instructions on the combine display to configure the row guidance system (if equipped). For assistance, refer to the combine operator’s manual.

NOTE:

The combine must be steering ready, and have row guidance activated in order to use row guidance sensors. Contact your Case dealer for more information.

6.3.1 Header Settings Quick Reference – Case AFX Display

The following table provides recommended auto header height (AHHC) settings for C Series Corn headers connected to Case combines with AFX displays.

NOTE:

Some options/selections may not be available unless the combine display is in Dealer Mode.

Setup Parameter	Setting	Notes
Maximum work height	75 %	—
Header type	Corn	Required.
Cutting type	Row	Required.
Frame type	Rigid	Select based on frame style: rigid for rigid headers; folding for folding headers.
Feeder speed corn	Full range	—
Header sensors	Enabled	If AHHC is installed, you must select ENABLED.
Header pressure float	Disabled	—
Header tilt response	Fast	—

CONFIGURING COMBINE

Setup Parameter	Setting	Notes
Pressure float override	20 %	—
Auto height override	No	—
Auto header lift	Yes	Customer preference
HHC raise rate	230	May be effected by header weight.
HHC lower rate	200	May be effected by header weight.
HHC height sensitivity	200	—
HHC tilt sensitivity	150	—
HHC tilt rate	100	—
Reel speed minimum	3.2 km/h (2.0 mph)	—
Reel speed slope	100	—
Reel drive type	Hydraulic	—
Reel speed sensor	No	—
Reel sensor horizontal	No	—
Reel end dividers	Yes	If the header is equipped with rotary end dividers (REDs).
Knife fore/aft	No	Select YES for folding headers.
Deck plates	Hydraulic	—
Header lateral tilt	Yes	Required
Auto tilt	No	—
Auto level at headland	Yes	—

6.4 Configuring Challenger[®], Gleaner[®], and Massey Ferguson[®] Combines

Challenger[®], Gleaner[®], and Massey Ferguson[®] combines can be configured to use rotary end dividers (REDs) and auto header height control (AHHC) if necessary.

Setting up REDs

1. Follow the instructions on the combine display to set up REDs. For assistance, refer to the combine operator's manual.
2. To engage the reel drive pump on the combine, harness pins 17 and 18 must be connected together. Plug 1.379.630 is used to complete the circuit. RED speed can then be controlled using the reel speed control on the side console.

Configuring auto header height control (AHHC)

3. Follow the instructions on the combine display to configure the AHHC. For assistance, refer to the combine operator's manual.

6.5 Configuring CLAAS Combines

CLAAS combines can be configured to use rotary end dividers (REDs) and auto header height control (AHHC) if necessary. A folding switch can be installed in the combine cab for use with folding headers.

Setting up REDs

1. To engage the reel drive pump on the combine, pins XA13 and XC5 must be connected together. The pins are provided in the harness. RED speed can then be controlled using the reel speed control on the side console.

Configuring auto header height control (AHHC)

2. Follow the instructions on the combine display to configure the AHHC. For assistance, refer to the combine operator's manual.

Installing folding switch

3. A switch is included in the parts crate for CLAAS configured folding headers. If the folding switch has not already been installed, it will be installed in the left side headliner in 700 series and prior machines to activate the folding circuit. Consult your Dealer for further instructions.

6.6 Configuring IDEAL™ Combines

IDEAL™ combines can be configured to use rotary end dividers (REDs) and auto header height control (AHHC) if necessary.

Setting up REDs

1. Follow the instructions on the combine display to set up REDs. For assistance, refer to the combine operator's manual.
2. To engage the reel drive pump on the combine, harness pins 17 and 18 must be connected together. Plug 1.379.630 is used to complete the circuit. RED speed can then be controlled using the reel speed control on the side console.

Configuring AHHC

3. Follow the instructions on the combine display to configure the AHHC. For assistance, refer to the combine operator's manual.

Required Combine Calibrations

- Feeder house drive calibration
- Header calibration
- Row guidance calibration (if equipped)

6.7 Configuring John Deere Combines

John Deere combines can be configured to use rotary end dividers (REDs) and auto header height control (AHHC) if necessary.

Setting up rotary end dividers (REDs)

1. To engage REDs on John Deere combines with GS4 displays, navigate to MENU – MACHINE SETTINGS – HEADER DETAILS and select ENABLE AUXILIARY FUNCTION (A). The speed of the REDs can then be controlled using the reel speed control on the side console.
2. To engage REDs on John Deere combines with GS3 displays, navigate to HEADER SETUP – HEADER WIDTH SETTINGS and select REEL INSTALLED. The speed of the REDs can then be controlled using the reel speed control on the side console.



Figure 6.3: John Deere Combine Display – Header Details Dialog Box

Configuring auto header height control (AHHC)

3. Follow the instructions on the combine display to configure the AHHC and row guidance. For assistance, refer to the combine operator's manual.

6.8 Configuring New Holland Combines

New Holland combines can be configured to use rotary end dividers (REDs) and auto header height control (AHHC) if necessary.

Setting up rotary end dividers (REDs)

1. On the combine display, navigate to the HEADER SETUP 1 page.
2. From DECK PLATES menu (A) and HYDRAULIC ROTATING DIVIDERS menu (B), select INSTALLED
3. **Folding headers:** from the FRAME TYPE pull-down menu (C), select FOLDING.



Figure 6.4: New Holland Combine Display – Header Setup 1 Page

Configuring auto header height control (AHHC)

4. Follow the instructions on the combine display to configure the AHHC and row guidance. For assistance, refer to the combine operator's manual.
5. Use the following buttons on the New Holland multifunction handle to control header functions:
 - Reel speed – controls snapping plate opening/gap
 - Reel fore/aft – activates fold/unfold on folding headers

NOTE:

When the header is engaged, reel fore/aft control is disabled to prevent damage to the folding or drive systems.

- Reel lift – adjusts rotary end divider speed (if installed)

Required Combine Calibrations

- Feeder house drive calibration
- Header calibration
- Row guidance calibration (if equipped)

6.8.1 Header Settings Quick Reference – New Holland Display

The following table provides recommended auto header height (AHHC) settings for C Series Corn headers connected to New Holland combines.

NOTE:

Some options/selections may not be available unless the combine display is in Dealer Mode.

CONFIGURING COMBINE

Setup Parameter	Setting	Notes
Header type	Rigid corn or variable speed corn	—
Deck plates	Installed	—
Hydraulic rotating dividers	Installed	If the header is equipped with rotary end dividers (REDs).
Frame type	Rigid (or folding)	Rigid if rigid, or Folding if folding type header.
Knife fore/aft	Not installed	Select INSTALLED for folding headers.
Hydraulic reel reverse	Not installed	—
Flip up kit	Not installed	—
Header blow-off	Not installed	—
Reel speed minimum	3.2 km/h (2.0 mph)	—
Reel speed offset	0.0 km/h (mph)	—
Maximum work height	75 %	Customer preference may supersede the recommendation.
Auto float	Installed	Required
Auto float II	Enabled	Required
Auto header lift	Installed	Customer preference may supersede the recommendation.
Auto tilt at headland	Installed	Customer preference may supersede the recommendation.
Auto level at headland	Installed	Customer preference may supersede the recommendation.
Pressure override threshold	20 bars (290 psi)	—
Height/tilt response	Fast	—
HHC height sensitivity	150	—
HHC tilt sensitivity	200	—
HHC raise slow rate	220	—
HHC raise fast rate	250	—
HHC lower slow rate	60	Setting affected by header weight.
HHC lower fast rate	150	Setting affected by header weight.
Header slip clutch	Not installed	—

Chapter 7: Setting up Row Guidance (Option)

This section describes the adjustments and setup required to ensure that the row guidance components are functional.

NOTE:

On Case and New Holland combines, the row guidance option requires an unlock code.

7.1 Checking and Adjusting Row Guidance Sensor Clearance (Option)

The position of the row guidance sensor arm must be checked.

NOTE:

For checking voltage from inside the combine cab, refer to the combine operator's manual.

The opening of the sensor wands should match the center of the row unit.

1. Ensure clearance (B) between sensor arms (A) is 15–25 mm (0.59–1.0 in.) and the gap is centered on the opening between the snapping rolls.
2. If adjustment is required, loosen three bolts (C), and rotate the wands to achieve the correct clearance.
3. Retighten bolts (C).

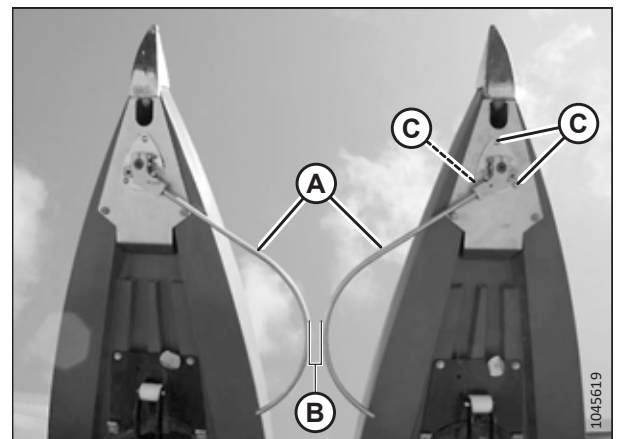

Figure 7.1: Row Guidance Sensor Arms

7.2 Checking Row Guidance Sensor Voltage (Option)

On headers equipped with the optional row guidance system, the row guidance sensor voltage should be checked to ensure the voltage range is compatible with the combine.

1. On the combine display's diagnostic page, view the row guidance sensor voltage values.
2. Compare the values to those in Table 7.1, page 84. If the combine display values are opposite to those in the table, refer to [7.3 Adjusting Row Guidance Sensor Voltage Orientation \(Option\)](#), page 85 for instruction about change sensor orientation.

Table 7.1 Row Guidance Sensor Voltage Limits

Combine	Left Sensor Voltage		Right Sensor Voltage	
	Wands extended	Wands retracted	Wands extended	Wands retracted
John Deere	0.7	4.2	4.2	0.7
Case, New Holland, CLAAS ⁷	0.7	4.2	0.7	4.2

-
7. At the time of publishing, we are unable to confirm the correct voltage range for Challenger, Fendt, Gleaner, IDEAL, and Massey Ferguson combines.

7.3 Adjusting Row Guidance Sensor Voltage Orientation (Option)

The row guidance sensor orientation may need to be changed to match the combine voltage requirements.

DANGER

To prevent injury or death from the unexpected start-up or fall of a raised machine, always stop the engine and remove the key from the ignition before leaving the operator's seat or making adjustments to the machine. Never work on or beneath an unsupported header. If the header is fully raised, always engage the safety props. If the header is off of the ground but not raised to its full height, place blocks under the header.

NOTE:

An optional voltage translator harness (1.369.178) can be installed in line with the row guidance sensor to switch between John Deere and other combine brands. The following procedure describes how to manually change the sensor orientation.

1. To access the row guidance sensor, remove bolts (A) and remove the sensor arm assembly from end of the snout.

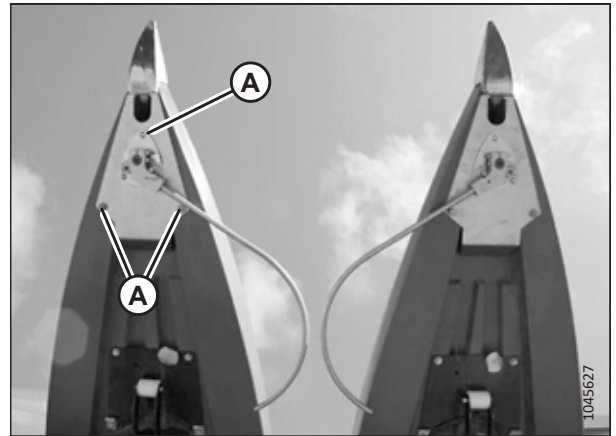

Figure 7.2: Row Guidance Sensor Arms

SETTING UP ROW GUIDANCE (OPTION)

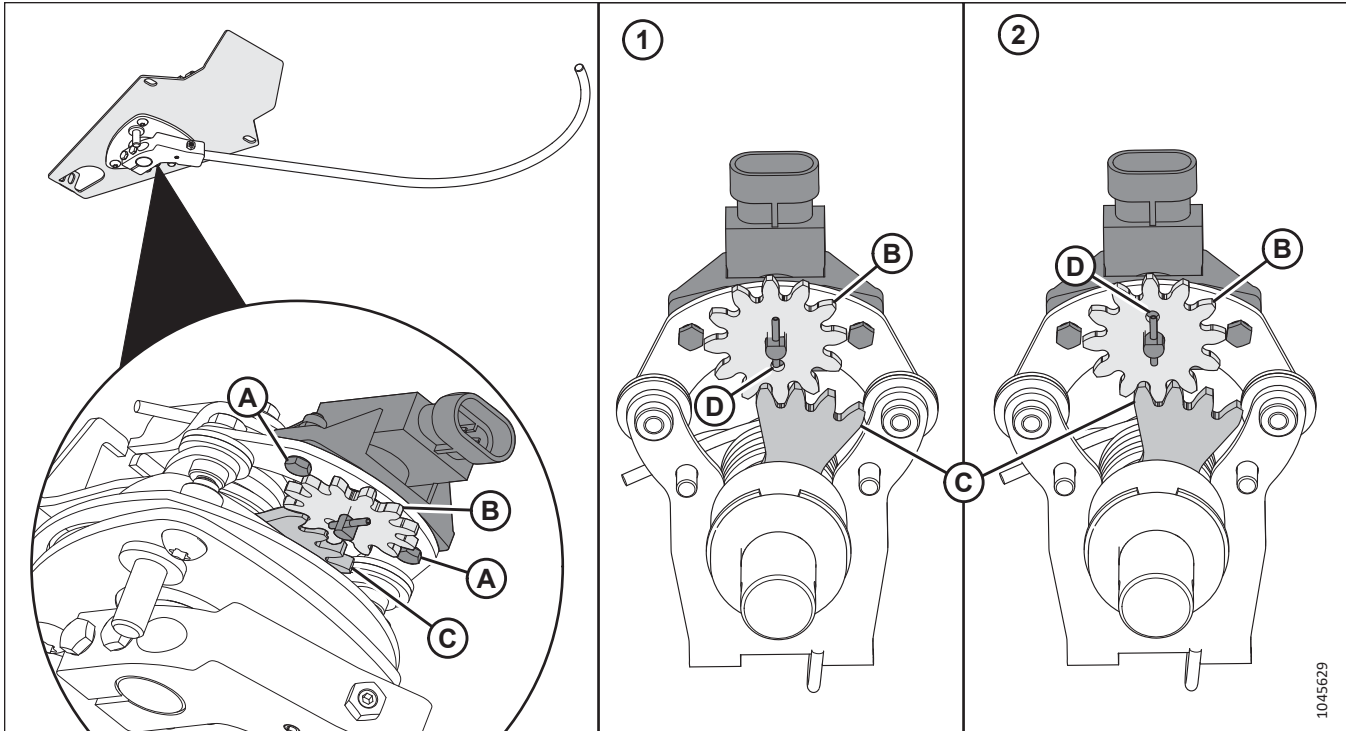

Figure 7.3: Row Guidance Sensor

- 1 - John Deere Configuration: Hole (D) Closest to Arm (C)
- 2 - Case, CLAAS, New Holland Configuration⁸: Hole (D) Farthest from Arm (C)

2. Loosen nuts and bolts (A) enough to allow sensor gear (B) to disengage from arm (C).
3. Rotate sensor gear (B) until hole (D) is positioned correctly for the combine type. Refer to Figure 7.3, page 86.
 - For John Deere combines refer to illustration section 1.
 - For Case, CLAAS, or New Holland combines⁸, refer to illustration section 2.
4. Retighten nuts and bolts (A) to secure the sensor.
5. Install the sensor arm assembly into the end of the snout, and secure it with bolts (A).

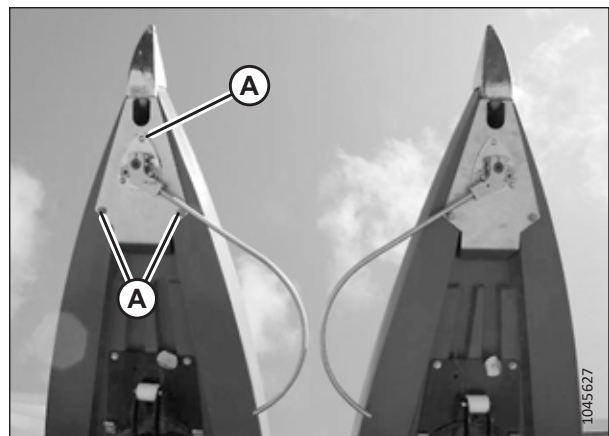

Figure 7.4: Row Guidance Sensor Arms

8. At the time of publishing, we are unable to confirm the correct configuration for Challenger, Fendt, Gleaner, IDEAL, and Massey Ferguson combines.

Chapter 8: Running up Header

The header needs to be operated and its performance observed before it can be delivered to the customer, to ensure that all of its features are functional. A 30 minute trial run is recommended.

DANGER

Ensure that all bystanders have cleared the area.

1. Start the combine and engage the drive with the engine speed at low idle. If all sounds well, run the header slowly.

IMPORTANT:

Avoid starting the drive at full throttle as the inertia load from acceleration can be 8–10 times more than the load from steady speed operation. High-speed startup may cause damage to the drive system and safety clutches.

2. After the slow speed start, increase the engine speed to a medium level, and listen for abnormal sounds. If no irregularity is observed, increase the engine speed to full throttle.
3. Engage the rotary end dividers (REDs) (if installed). Confirm that they turn the correct direction (left: clockwise; right: counterclockwise).
4. Check the lights and confirm that they turn on and off as expected.

8.1 Checking and Adjusting Orifices – Folding Headers

Folding headers are equipped with orifices that provide hydraulic flow restriction to control the movement of folding wings and snout lift cylinders. Alternative orifices are provided and can be installed to adjust for different combines.

Folding headers are factory-equipped with two 1.0 mm orifices in the base of each folding wing cylinder that enable the header wings to fold simultaneously on most combines. The orifices can be replaced with 0.7 mm orifices to synchronize a header that folds one wing and then the other.

The snout lift cylinders are factory-equipped with 5.0 mm orifices to control the lifting speed of the snouts during folding. They can be replaced with 1.0 mm orifices to reduce speeds on high flow combines. Four 0.7 mm orifices, and four 1.0 mm orifices are shipped inside the wooden shipping crate.

RUNNING UP HEADER

1. Fold the header and observe whether the wings fold simultaneously or one at a time.

The hydraulic circuit controlling the snapping plates also powers the folding system.

Selection and activation of folding varies by combine:

- John Deere, AGCO, and older Case and New Holland combines use selector switch (A) powered by an auxiliary power port in the cab. After selecting folding, the header is folded using the snapping plate adjustment (or reel fore-aft control).
- Newer Case and New Holland machines can fold the header without an external harness using the shift+ deck plate adjusting buttons. Header should be configured as CORN with FOLDABLE frame in the head 1 setting menu. In the head 2 menu, knife fore/aft should be YES and shift+ reel fore aft should be HEADER FEATURES.
- Some CLAAS combines use a switch located in the headliner of the machine to activate folding.

Consult the combine operator's manual for model-specific instructions.



Figure 8.1: Header Folding Switch

Wing cylinders

2. If the wings fold at different speeds, replace (1.0 mm) factory-installed orifices (B) on main fold cylinders (A) with the smaller ones (0.7 mm) provided in the shipping crate.

NOTE:

There is one fold cylinder on each side of the header. Each cylinder has a valve with two orifices.

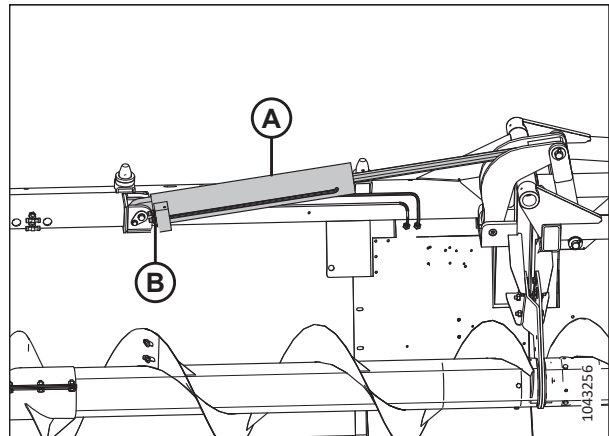

Figure 8.2: Check Valve on Left Wing Cylinder

Snout-lifting cylinders

3. If the snouts at the folding joint are rising too quickly, replace factory-installed 5.0 mm orifices (B) on dual-controlled check valves (A) with the smaller (1.0 mm) orifices provided in the shipping crate.

NOTE:

There is one dual-controlled check valve on each side of the header. Each valve has two orifices.

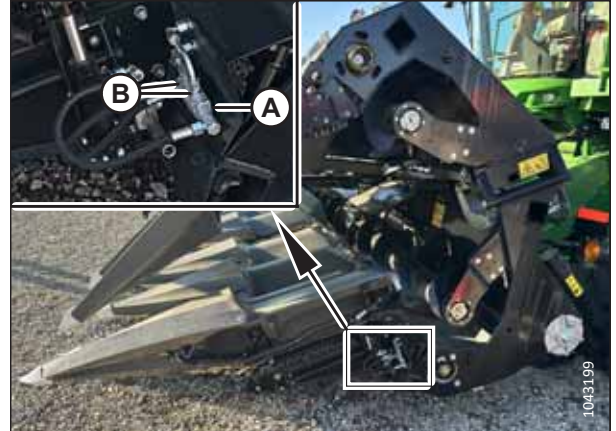

Figure 8.3: Check Valve on Left Snout-Lifting Cylinder

8.2 Checking Folding Operation – Folding Headers

On folding headers, test the folding operation to ensure that it works correctly. Folding is controlled from the combine cab.

NOTE:

The combine controls used to fold the header vary depending on the combine model. Refer to your combine operator’s manual for instructions.

1. Trigger the header folding operation from the combine cab, and ensure that the hydraulic cylinders operate in the following sequence:
 - a. The lock cylinders (D1 and D2), located below the auger, retract fully.
 - b. The rear divider cylinders (B1 and B2), located at the folding joints, extend fully.
 - c. The wing cylinders (A1 and A2), located on the top rear of the header, retract to fold the wings.

NOTE:

Refer to Figure 8.5, page 91.

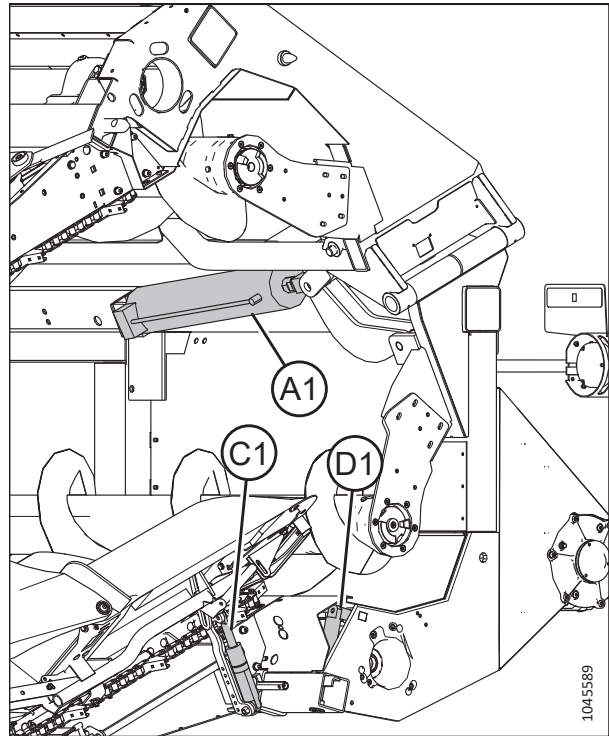
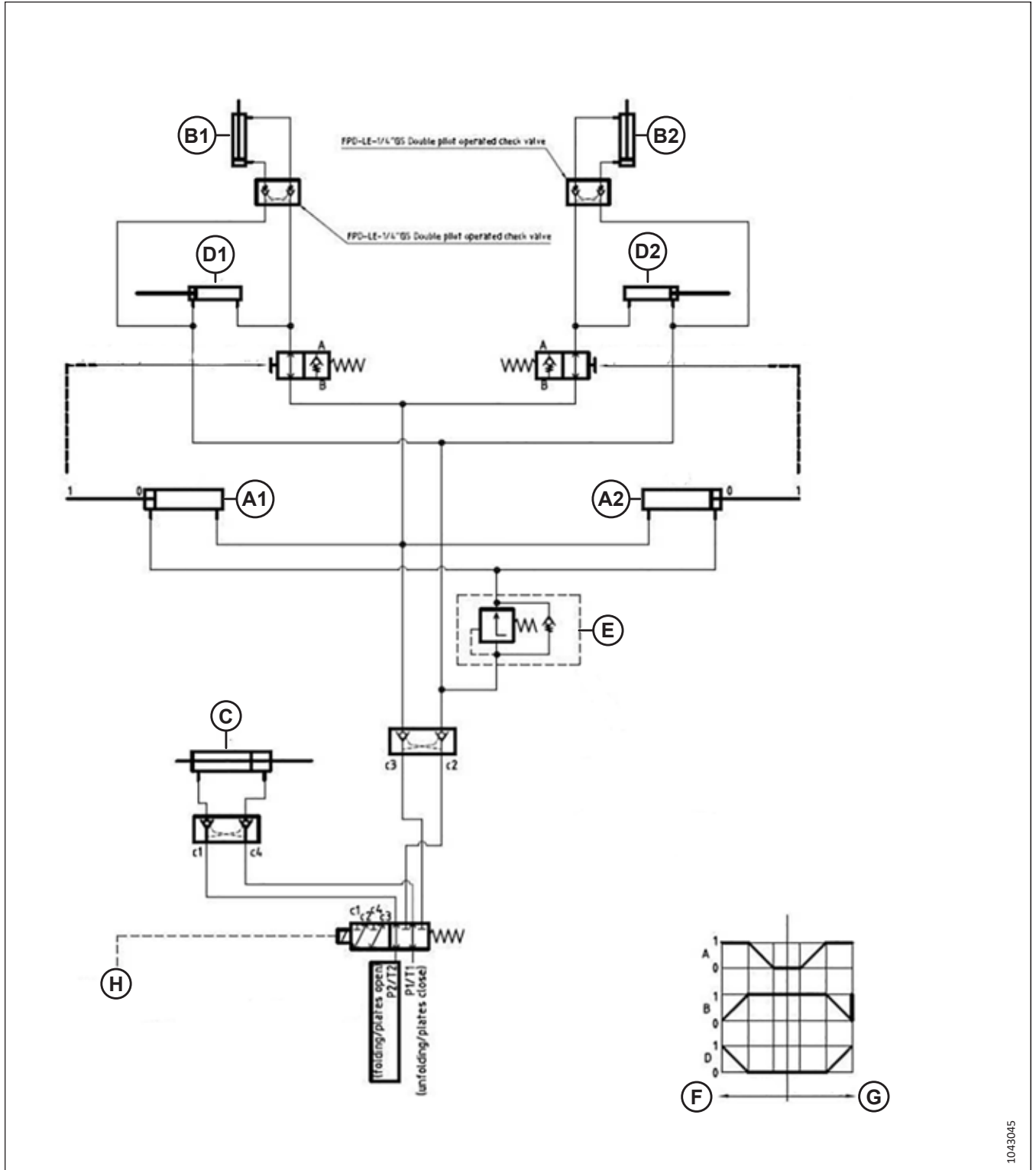

Figure 8.4: Cylinder Locations – Left Side

RUNNING UP HEADER



1043045

Figure 8.5: Hydraulic Schematic – Folding Headers

A1 and A2- Wing Cylinders
 D1 and D2- Locking Cylinders
 G - Unfolding

B1 and B2- Rear Divider Cylinders
 E - Pressure Relief Valve
 H - Energized: Folding; De-energized: Snapping Plate Opens

C - Snapping Plate Cylinder
 F - Folding

RUNNING UP HEADER

2. If the wing cylinders start moving before the other cylinders (D1, D2, B1, and B2) reach their end positions, locate pressure relief valve adjuster screw (A) on the valve block on the rear of the header, to the left of the delivery opening. Turn the screw half a turn clockwise, then recheck the hydraulic cylinders.
3. Repeat this procedure as necessary until the header folds correctly.



Figure 8.6: Pressure Relief Valve Adjuster Screw

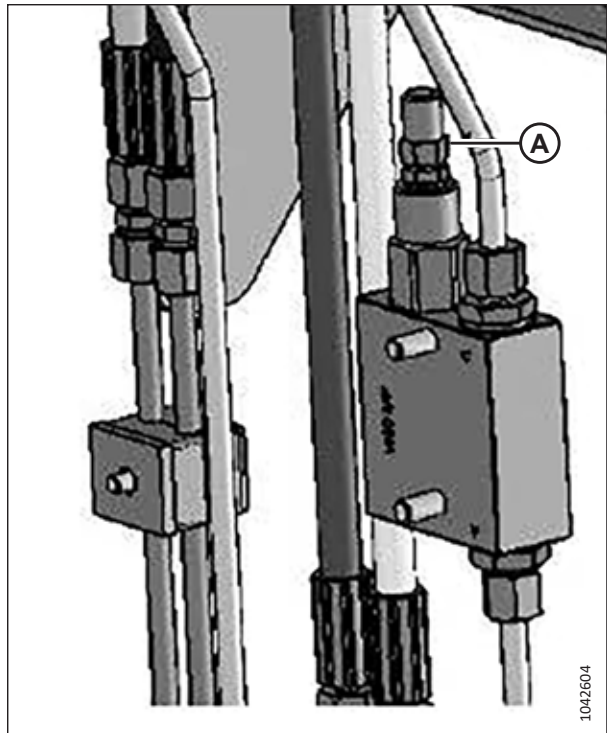

Figure 8.7: Close-up of Pressure Relief Valve Adjuster Screw

Chapter 9: Reference

Additional information and commonly repeated procedures are included in the reference chapter.

9.1 Torque Specifications

The following tables provide torque values for various bolts, cap screws, and hydraulic fittings. Refer to these values only when no other torque value has been specified in a given procedure.

- Tighten all bolts to the torque values specified in the charts below, unless you are directed otherwise in this manual.
- Replace removed hardware with hardware of the same strength and grade.
- Refer to the torque value tables as a guide when periodically checking the tightness of bolts.
- Understand the torque categories for bolts and cap screws by reading the markings on their heads.

Jam nuts

Jam nuts require less torque than nuts used for other purposes. When applying torque to finished jam nuts, multiply the torque applied to regular nuts by 0.65 to obtain the modified torque value.

Self-tapping screws

Refer to the standard torque values when installing the self-tapping screws. Do **NOT** install the self-tapping screws on structural or otherwise critical joints.

9.1.1 Torque Specifications for Fasteners

Specifications are provided for the appropriate final torque values to secure various sizes of metric bolts, screws, and nuts.

NOTE:

The torque values provided in the following metric bolt torque tables apply to hardware installed dry; that is, hardware with no grease, oil, or threadlocker on the threads or heads. Do **NOT** add grease, oil, or threadlocker to bolts or cap screws unless you are directed to do so in this manual.

Table 9.1 Torque Values for Fasteners (Nm)

Size	Quality		
	Class 8.8	Class 10.9	Class 12.9
Bolts/Screws			
Nuts	Class 8	Class 10	Class 12
M6	10	14	16
M8	23	33	40
M10	45	63	75
M12	78	110	130
M14	122	175	210
M16	195	270	325
M18	260	370	440
M20	370	525	630
M24	640	900	1080
M30	1260	1800	2160

REFERENCE

Table 9.2 Torque Values for Fasteners (lbf·ft)

Size	Quality		
	Bolts/Screws	Class 8.8	Class 10.9
Nuts	Class 8	Class 10	Class 12
M6	7	10	12
M8	17	24	30
M10	33	46	55
M12	58	81	96
M14	90	129	155
M16	144	199	240
M18	192	273	325
M20	273	387	465
M24	472	664	797
M30	929	1328	1593

9.1.2 Torque Specifications for Hydraulic Fittings

The standard torque values for hydraulic ring tube fittings are provided. If a procedure specifies a different torque value for the same type and size of fitting found in this topic, use the value specified in the procedure instead.

Table 9.3 Dimensions and Torque Specifications – L Series

Size	Minimum Tube Wall Thickness	Torque Value	
		Nm	lbf·ft (*lbf·in)
6	6 x 1	25	*221
8	8 x 1	40	30
10	10 x 1	50	37
12	12 x 1.5	70	52
15	15 x 1.5	90	66
18	18 x 1.5	115	85
22	22 x 2	210	155
28	28 x 2	310	229
35	35 x 3	500	369
42	42 x 3	600	443

Table 9.4 Dimensions and Torque Specifications – S Series

Size	Minimum Tube Wall Thickness	Torque Value	
		Nm	lbf·ft
6	6 x 2	35	26
8	8 x 1.5	55	41
10	10 x 1.5	70	52
12	12 x 1.5	85	63
14	14 x 2	110	81
16	16 x 1.5	120	89
20	20 x 2	200	148
25	25 x 2.5	340	251
30	30 x 3	480	354
38	38 x 4	850	627

9.2 Conversion Chart

This manual uses both SI units (including metric) and US customary units (sometimes referred to as standard units) of measurement. A list of those units along with their abbreviations and conversion factors is provided here for your reference.

Table 9.5 Conversion Chart

Quantity	SI Units (Metric)		Factor	US Customary Units (Standard)	
	Unit Name	Abbreviation		Unit Name	Abbreviation
Area	hectare	ha	x 2.4710 =	acre	acres
Flow	liters per minute	L/min	x 0.2642 =	US gallons per minute	gpm
Force	Newton	N	x 0.2248 =	pound force	lbf
Length	millimeter	mm	x 0.0394 =	inch	in.
Length	meter	m	x 3.2808 =	foot	ft.
Power	kilowatt	kW	x 1.341 =	horsepower	hp
Pressure	kilopascal	kPa	x 0.145 =	pounds per square inch	psi
Pressure	megapascal	MPa	x 145.038 =	pounds per square inch	psi
Pressure	bar (Non-SI)	bar	x 14.5038 =	pounds per square inch	psi
Torque	Newton meter	Nm	x 0.7376 =	pound feet or foot pounds	lbf·ft
Torque	Newton meter	Nm	x 8.8507 =	pound inches or inch pounds	lbf·in
Temperature	degrees Celsius	°C	(°C x 1.8) + 32 =	degrees Fahrenheit	°F
Velocity	meters per minute	m/min	x 3.2808 =	feet per minute	ft/min
Velocity	meters per second	m/s	x 3.2808 =	feet per second	ft/s
Velocity	kilometers per hour	km/h	x 0.6214 =	miles per hour	mph
Volume	liter	L	x 0.2642 =	US gallon	US gal
Volume	milliliter	mL	x 0.0338 =	ounce	oz.
Volume	cubic centimeter	cm ³ or cc	x 0.061 =	cubic inch	in. ³
Weight	kilogram	kg	x 2.2046 =	pound	lb.

9.3 Definitions

The following terms, abbreviations, and acronyms are used in this instruction.

Table 9.6 Definitions

Term	Definition
AHHC	Automatic header height control
API	American Petroleum Institute
Bolt	A headed and externally threaded fastener designed to be paired with a nut
FFFT	Flats from finger tight
Field configuration	Also known as working position. The configuration of the machine when working in the field.
Finger tight	A reference position in which the given sealing surfaces or components are making contact with each other. The fitting has been tightened by hand to a point where the fitting is no longer loose and cannot be tightened further by hand
JIC	Joint Industrial Council: A standards body that developed standard sizing and shape for the original 37° flared fitting
n/a	Not applicable
NPT	National Pipe Thread: A style of fitting used for low-pressure port openings. Threads on NPT fittings are uniquely tapered for an interference fit
Nut	An internally threaded fastener designed to be paired with a bolt
ORB	O-ring boss: A style of fitting commonly used in port openings on manifolds, pumps, and motors
ORFS	O-ring face seal: A style of fitting commonly used for connecting hoses and tubes. This style of fitting is also commonly called ORS, which stands for O-Ring Seal
RED	Rotary end divider
SAE	Society of Automotive Engineers
Screw	A headed and externally threaded fastener that threads into preformed threads or forms its own thread when it is inserted into a mating part
Shipping configuration	The configuration of the machine when it is shipped from the factory
TED	Tall end divider
Tension	An axial load placed on a bolt or screw, usually measured in Newtons (N) or pounds (lb.). This term can also be used to describe the force a belt exerts on a pulley or sprocket
TFFT	Turns from finger tight
Torque	The product of a force * the length of a lever arm, usually measured in Newton-meters (Nm), foot-pounds (lbf-ft), or inch-pounds (lbf-in)
Torque angle	A tightening procedure in which a fitting is assembled to a specified tightness (usually finger tight) and then the nut is turned farther by a specified number of degrees until it achieves its final position
Torque-tension	The relationship between the assembly torque applied to a piece of hardware and the axial load it induces in a bolt or screw
Transport configuration	The configuration of the machine when it is being transported between fields.
Washer	A thin cylinder with a hole or a slot located in the center, used as a spacer, a load distribution element, or a locking mechanism

Predelivery Checklist

Perform these checks and adjustments before delivering the machine to your Customer. If adjustments are required, refer to the appropriate page number in this manual. The completed Checklist should be retained by either the Operator or the Dealer.

CAUTION

Carefully follow the instructions given. Be alert for safety-related messages that bring your attention to hazards and unsafe practices.

Header Serial Number:

✓	Step	Item	Reference
	1	Check for shipping damage and missing parts	<i>3.2 Inspecting Header, page 12</i>
	2	Verify that the input gearbox configuration is correct for the combine	<i>3.2 Inspecting Header, page 12</i>
	3	Verify that the gathering chain tool is present	<i>3.2 Inspecting Header, page 12</i>
	4	Verify that the operator's manual and parts catalog are present	<i>3.2 Inspecting Header, page 12</i>
	5	Verify that the hydraulic completion is correct for the combine	<i>3.2 Inspecting Header, page 12</i>
	6	Verify that the electrical completion is correct for the combine	<i>3.2 Inspecting Header, page 12</i>
	7	Verify that the transition frame completion is correct for the combine	<i>3.2 Inspecting Header, page 12</i>
	8	Check the snapping roll clearances	<i>4.1 Preparing Header While in Standing Position, page 17</i>
	9	Check the vine knife clearances	<i>4.1 Preparing Header While in Standing Position, page 17</i>
	10	Ensure the chopper gearboxes are fully engaged prior to runup (if applicable)	<i>4.1 Preparing Header While in Standing Position, page 17</i>
	11	Ensure that the chopper knives rotate freely (if applicable)	<i>4.1 Preparing Header While in Standing Position, page 17</i>
	12	Ensure that the clearance lights are in field configuration	<i>4.4 Preparing Header for Combine Attachment, page 26</i>
	13	Pick up the header with the combine	<i>4.5 Attaching Header to Combine, page 29</i>
	14	Ensure the transition frame latches are properly secured to the feeder house	<i>4.5.1 Adjusting Latching Hooks, page 29</i>
	15	Ensure that the drive shafts are properly connected to the combine feeder house	<i>4.5.2 Attaching Drivelines to Combine, page 32</i>
	16	Ensure that the shipping brackets and packaging have been removed	<i>4.6 Removing Shipping Components, page 34</i>
	17	Ensure end dividers have been properly installed	<i>4.7 Installing End Dividers, page 36</i>
	18	Ensure the end divider latches are properly adjusted and secured	<i>4.7.4 Checking and Adjusting End Divider Latches, page 41</i>
	19	Ensure that the snouts have all been attached	<i>4.8 Installing Snouts and Snout Height Supports, page 42</i>
	20	Ensure auto header height control (AHHC) wires are connected and secure.	<i>4.8 Installing Snouts and Snout Height Supports, page 42</i>

REFERENCE

✓	Step	Item	Reference
	21	Check the header angle	<i>5.1 Checking and Adjusting Header Angle, page 51</i>
	22	Set the snout tip height	<i>5.2 Checking and Adjusting Snout Height, page 52</i>
	23	Check the snapping plate clearances	<i>5.3 Checking and Adjusting Snapping Plate Gap, page 53</i>
	24	Check the snapping plate setting	<i>5.3 Checking and Adjusting Snapping Plate Gap, page 53</i>
	25	Ensure the correct auger flighting is installed for the conditions	<i>5.5 Checking and Adjusting Auger Flighting Configuration, page 56</i>
	26	Check the auger clearances	<i>5.6 Checking and Adjusting Auger Position, page 57</i>
	27	Check the auger drive chain tension	<i>5.7 Checking and Adjusting Auger Drive Chain Tension, page 60</i>
	28	Check the auger phasing left to right (if applicable)	<i>5.10 Checking and Adjusting Auger Timing – Folding Headers, page 63</i>
	29	Check the fluid level in the input drive gearbox(es) and input driven gearbox(es)	<i>5.11.1 Checking and Adjusting Oil Level – Input Gearboxes, page 65</i>
	30	Check the fluid level in the snapping unit gearbox	<i>5.11.2 Checking and Adjusting Lubricant Level – Snapping Unit Gearbox, page 66</i>
	31	Check the fluid level in the chopper gearbox (if applicable)	<i>5.11.3 Checking and Adjusting Oil Level – Stalk Chopper Gearbox (Option), page 67</i>
	32	Grease all bearings and drivelines	<i>5.12 Lubricating Header, page 68</i>
	33	Verify that the folding/unfolding operation works correctly (if applicable)	<i>8.2 Checking Folding Operation – Folding Headers, page 90</i>
	34	Calibrate the AHHC (if applicable)	Combine operator’s manual
	35	Check the row guidance system setup and sensor voltage (if applicable)	<i>7 Setting up Row Guidance (Option), page 83</i>
	36	Run up the header in forward and reverse	<i>8 Running up Header, page 87</i>
	37	Check the header speed	<i>8 Running up Header, page 87</i>
	38	Check for loose hardware	—

Date Checked:

Checked by:

Recommended Fluids and Lubricants

Ensure your machine operates at top efficiency by using clean fluids and lubricants only.

- Use clean containers to handle all fluids and lubricants.
- Store fluids and lubricants in an area protected from dust, moisture, and other contaminants.

Lubricant	Specification	Description	Use	Capacities
Grease	SAE multi-purpose	High temperature extreme pressure (EP) performance with 1% max. molybdenum disulphide (NLGI Grade 2) lithium base	As required unless otherwise specified	—
		High temperature extreme pressure (EP) performance with 10% max. molybdenum disulphide (NLGI Grade 2) lithium base	Header drive shaft	—
Semi-fluid grease	EP-00	Extreme pressure (EP) performance with lithium base	Row unit main gearbox	2.5 liters (2.6 quarts)
Gear lubricant	SAE 80W-140 or SAE 85W-140	API service class GL-5	Stalk chopper gearbox	0.3 liters (0.3 quarts)
			Input drive and driven gearboxes	0.9 liters (1.0 quarts)
Chain lubricant	Chain lubricant or SAE 30W oil	Chain oil is formulated to provide good wear protection and resistance to foaming. It protects the chain and drive sprockets against wear.	Auger drive chain, hex shaft chain couplings, and snapping plate indicator chain	—

MacDon®

CUSTOMERS
MacDon.com

DEALERS
Portal.MacDon.com

Trademarks of products are the marks of their
respective manufacturers and/or distributors.

Printed in Hungary