

D2 Series Draper Header with FM200 Float Module

Unloading and Assembly Instructions (North America)

262332 Revision A

Original Instruction

D2 Series Draper Header

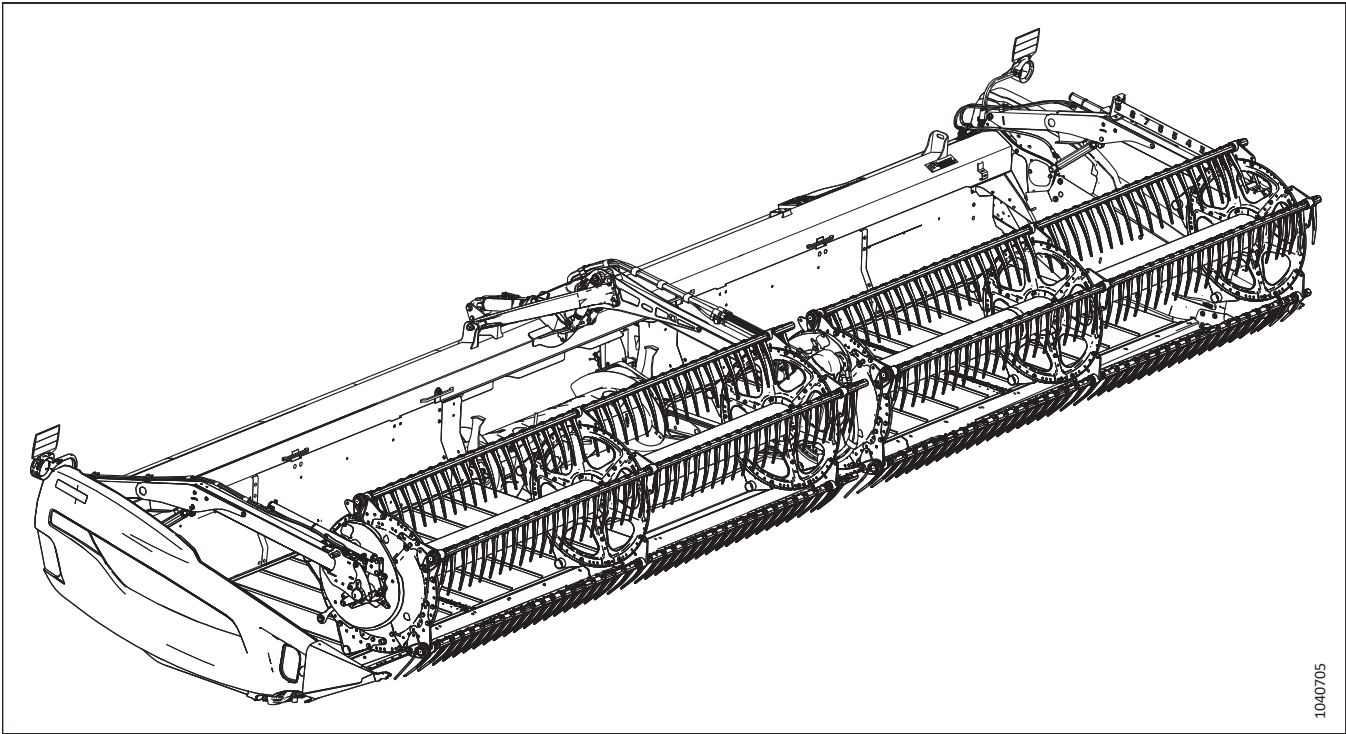

1040705

Published: February 2024

© 2024 MacDon Industries, Ltd.

The information in this publication is based on the information available and in effect at the time of printing. MacDon Industries, Ltd. makes no representation or warranty of any kind, whether expressed or implied, with respect to the information in this publication. MacDon Industries, Ltd. reserves the right to make changes at any time without notice.

Introduction

This instruction manual describes the unloading, setup, and predelivery requirements for the MacDon D2 Series Draper Header with FM200 Float Module.

To ensure the best performance from this product and the safety of your customers, carefully follow this unloading and assembly procedure from the beginning through to completion.

Some sections or steps do not apply to all header configurations and sizes. Follow the instructions for the particular header you are assembling.

Carefully read all of the instructions provided before attempting to unload, assemble, or operate the header.

If the shipment is damaged or is missing parts, contact shortageanddamage@macdon.com.

Retain this instruction for future reference.

NOTE:

Keep your MacDon publications up-to-date. The latest version can be downloaded from our website (www.macdon.com) or from our Dealer portal (<https://portal.macdon.com>) (login required).

This document is currently available in English only.

Summary of Changes

The following list provides an account of major changes from the previous version of this document.

Section	Summary of Change	Internal Use Only
<i>1.5 Welding Precautions, page 6</i>	Added topic.	Technical Publications
<i>2.1 Header Specifications for Unloading and Assembly, page 9</i>	Revised the header weight specifications table to include the weight of the float module.	Technical Publications
<i>2.6 Lowering Header to Field Position – D225, page 17</i>	Revised procedure for tipping the header into field position.	Product Support
<i>2.7 Lowering Header to Field Position – D230 and D235, page 21</i>	Added steps and illustration for lifting the rear of the float module and blocking it.	Product Support
—	Removed the following topics because headers configured for New Holland will no longer be shipped with the associated feed auger kits: <ul style="list-style-type: none"> • “Setting Up Feed Opening on Float Modules for New Holland” • “Replacing Feeder Deflectors on Float Modules for New Holland CR and CX Combines” 	ECN 63619
<i>3.6 Retrieving Limiter Link – CLAAS Lexion Combines, page 48</i>	<ul style="list-style-type: none"> • Added the step to retrieve the customer’s combine. • Specified that the procedure only applies to CLAAS 5/6/7/8000 series and TRION series combines. • Move limiter link installation steps to <i>4.3.1 Installing Limiter Link and Performing a Fore/Aft Tilt Calibration – CLAAS Lexion 5/6/7/8000 Series and TRION Series, page 67</i>, and revised a hazard statement and steps. 	Technical Publications Product Support Engineering
<i>3.7 Retrieving Two-Position Adjustment Plates – John Deere X9 Series Combines, page 49</i>	Added topic.	ECN 64613
<i>4 Attaching Header to Combine, page 51</i>	<ul style="list-style-type: none"> • “CLAAS 500 Series” relabeled as “CLAAS/CAT-Lexion Models”, and added “600” to the list. • Added New Holland model CH. 	ECR 32134 ECN 64068
<i>4.1 Attaching Header to Case IH Combine, page 52</i>	<ul style="list-style-type: none"> • Deleted “Start the engine” step. • Added the condition "If MacDon in-cab controls are installed" to steps concerning connectors C81A and C81B. • Revised the step about float locks to clarify when the locks should be left locked or unlocked. 	ECN 64329

Section	Summary of Change	Internal Use Only
<p><i>4.2 Attaching Header to Challenger®, Gleaner®, or Massey Ferguson® Combine, page 57</i></p>	<ul style="list-style-type: none"> • Deleted “Start the engine” step. • Illustration 1043218 replaces 1001486 to show the feeder house tool and latch mechanism. • Deleted “Lower the header fully” step. • Revised the step and illustration about float locks to clarify when the locks should be left locked or unlocked. 	<p>Technical Publications Product Support</p>
<p><i>4.3 Attaching Header to CLAAS Combine, page 62</i></p>	<ul style="list-style-type: none"> • Deleted “Start the engine” steps. • Deleted “Lower the header fully” step. • Deleted "Remove the blocks from under the cutterbar" step. • Replaced illustration 1039435 with 1035174. Added the condition "If MacDon in-cab controls are installed" to the step concerning connectors C81A and C81B. • Revised the last step to clarify when the float locks should be left locked or unlocked. 	<p>Engineering</p>
<p><i>4.3.1 Installing Limiter Link and Performing a Fore/Aft Tilt Calibration – CLAAS Lexion 5/6/7/8000 Series and TRION Series, page 67</i></p>	<p>Added topic.</p>	<p>Technical Publications Product Support</p>
<p><i>4.4 Attaching Header to IDEAL™ Series Combine, page 72</i></p>	<ul style="list-style-type: none"> • Deleted “Start the engine” step. • Added “Shut the engine off” step. • Replaced illustration 1038495 with 1043031. Added the step concerning connectors C81A and C81B. • Added the last step to clarify when the float locks should be left locked or unlocked. 	<p>Engineering</p>
<p><i>4.5 Attaching Header to John Deere Combine, page 76</i></p>	<ul style="list-style-type: none"> • Deleted “Start the engine” step. • Added X9 series one- and two-position adjustment plate content. • Revised steps concerning the attachment of the multicoupler to the combine, and feeder house locking pin engagement. • Revised the last step to clarify when the float locks should be left locked or unlocked. 	<p>Technical Publications ECN 64613</p>
<p><i>4.6 Attaching Header to New Holland CR, CX, or CH Combine, page 84</i></p>	<ul style="list-style-type: none"> • Deleted “Start the engine” step. • Added the condition "If MacDon in-cab controls are installed" to steps concerning connectors C81A and C81B. • Revised the last step to clarify when the float locks should be left locked or unlocked. 	<p>ECN 64329</p>

Section	Summary of Change	Internal Use Only
<i>4.7 Attaching Header to Rostselmash Combine, page 89</i>	<ul style="list-style-type: none"> Deleted "Start the engine" step. Revised the last step to clarify when the float locks should be left locked or unlocked. 	Technical Publications
<i>3.5 Installing Cab Control Kits (Parts Bags MD #337619 or 337627), page 47</i>	<p>Removed the following cab control kits:</p> <ul style="list-style-type: none"> Removed CLAAS cab control kit MD #337611. Case New Holland kit MD #357970. 	ECR 32906 ECN 64329
<i>5.2 Removing Shipping Supports, page 97</i>	Updated the illustration showing the left and right shipping straps that attach the float module legs to the header.	ECN 65226
<i>5.7 Installing Deck Cutterbar Seals – D230 (Parts Bag MD #335987), page 113</i>	Replaced "Unmarked Parts Bag" with "Parts Bag MD #335987".	Technical Publications
<i>5.8 Installing Deck Cutterbar Seal – D235 (Parts Bag MD #335988), page 116</i>	Replaced "Unmarked Parts Bag" with "Parts Bag MD #335988".	Technical Publications
<i>5.6 Installing Reel Lift Cylinders – Double Reel, D230 and D235, page 106</i>	Added instructions for reconnecting the reel lift cylinder hoses (illustration 1043823 and associated steps).	ECN 65175
<i>5.11 Attaching Reel Height Sensor, page 124</i>	<ul style="list-style-type: none"> Added Challenger®, Gleaner®, Massey Ferguson®, and Rostselmash information below the sensor orientation illustration. Changed the imperial torque value of 70 lbf-in to 73 lbf-in. 	Engineering Technical Publications
<i>5.12 Installing Reel Fore-Aft Steel Lines (Parts Bag MD #357107), page 127</i>	Added clamp torque of 7 Nm (5 lbf-ft [62 lbf-in]).	Engineering
<i>5.14 Connecting Reel to Fore-Aft Cylinders, Single-Reel Headers – D225 (Parts Bag MD #357467), page 130</i>	Fore-aft cylinder position illustration 1043629 replaces 1041019 to show more context.	Product Support
<i>5.15 Connecting Reel to Fore-Aft Cylinders – Double-Reel Headers D230 and D235 (Parts Bag MD #347580), page 136</i>	Fore-aft cylinder position illustration 1043629 replaces 1041019 to show more context.	Product Support
<i>5.16 Installing Reel Fore-Aft Hose Clamp – D230 and D235, page 142</i>	Moved this topic to this location (after the reel fore-aft cylinders are connected).	Product Support
<i>5.17.1 Installing Tine Tube onto Reel – D225 (Parts Bag MD #357394), page 143</i>	Added IMPORTANT: "Mounting the tine tubes onto the mid-discs according to specification helps maintain an even and correct clearance between the fingers and cutterbar."	Product Support
<i>5.18 Installing Single-Reel Endshields, Nine-Bat – D225 (Parts Bag MD #368328), page 150</i>	Parts bag MD #368328 replaces MD #311363.	ECN 64055
<i>5.18.1 Installing Single-Reel Endshields at Cam End – Nine-Bat, page 151</i>	<ul style="list-style-type: none"> Parts bag MD #368328 replaces MD #311363. Parts bag MD #368338 replaces MD #360020. Step associated with endshield mounting bracket hardware (illustration 1040594): 68.5 Nm (50.5 lbf-ft) rounded up to 69 Nm (51 lbf-ft). 	ECN 64055 Engineering

Section	Summary of Change	Internal Use Only
<p><i>5.18.2 Installing Single-Reel Endshields at Tail End – Nine-Bat, page 158</i></p>	<p>Updated parts bags as follows:</p> <ul style="list-style-type: none"> • Parts bag MD #368328 replaces MD #311363. • Parts bag MD #368337 replaces MD #360019. <p>Corrected the topic as follows:</p> <ul style="list-style-type: none"> • Deleted bolt MD #320180 and nut MD #136431 because they were never used in this parts bag. • Corrected quantity of nut MD #135799 from 9 to 18. • Added bolt MD #152655. • Corrected assembly steps associated with the parts corrections listed above. • Corrected step associated with endshield mounting bracket (illustration 1040670): Corrected hardware size from M12 to M10. Torque of 68.5 Nm (50.5 lbf-ft) corrected to 39 Nm (29 lbf-ft). 	<p>ECN 64055 Technical Publications</p>
<p><i>5.19 Installing Double-Reel Endshields – Parts Bag MD #368322 (Five-Bat Reels) or MD #368323 (Six-Bat Reels), page 165</i></p>	<p>Removed the parts lists. Updated parts bags as follows:</p> <ul style="list-style-type: none"> • Parts bag MD #368322 replaces MD #340985. • Parts bag MD #368323 replaces MD #340986. 	<p>ECN 64055</p>
<p><i>5.19.1 Installing Double-Reel Endshields at Outboard Cam End, page 166</i></p>	<p>Updated parts bags as follows:</p> <ul style="list-style-type: none"> • Parts bag MD #368322 replaces MD #340985. • Parts bag MD #368323 replaces MD #340986. • Parts bag "RH CAM" replaces "Bag #4". <p>Step associated with endshield mounting bracket hardware (illustration 1037035): 68.5 Nm (50.5 lbf-ft) rounded up to 69 Nm (51 lbf-ft).</p>	<p>ECN 64055</p>
<p><i>5.19.2 Installing Double-Reel Endshields at Inboard Tail End, page 174</i></p>	<ul style="list-style-type: none"> • Added first step and IMPORTANT concerning raising/lowering the reel fully to fill the hydraulic lines with oil and to purge them of air. • Updated parts bags as follows: <ul style="list-style-type: none"> – Parts bag MD #368322 replaces MD #340985. – Parts bag MD #368323 replaces MD #340986. – Parts bag "RH" replaces "Bag #3". 	<p>Product Support ECN 64055</p>

Section	Summary of Change	Internal Use Only
5.19.3 Installing Double-Reel Endshields at Inboard Cam End, page 181	<ul style="list-style-type: none"> • Added first step and IMPORTANT concerning raising/lowering the reel fully to fill the hydraulic lines with oil and to purge them of air. • Updated parts bags as follows: <ul style="list-style-type: none"> – Parts bag MD #368322 replaces MD #340985. – Parts bag MD #368323 replaces MD #340986. – Parts bag "LH CAM" replaces "Bag #2". • Step associated with endshield mounting bracket hardware (illustration 1037274): 68.5 Nm (50.5 lbf-ft) rounded up to 69 Nm (51 lbf-ft). 	ECN 64055
5.19.4 Installing Double-Reel Endshields at Outboard Tail End, page 188	<p>Updated parts bags as follows:</p> <ul style="list-style-type: none"> • Parts bag MD #368322 replaces MD #340985. • Parts bag MD #368323 replaces MD #340986. • Parts bag "LH" replaces "Bag #1". <p>Corrected step associated with endshield mounting bracket (illustration 1037025): Torque of 68.5 Nm (50.5 lbf-ft) corrected to 39 Nm (29 lbf-ft).</p>	ECN 64055
—	<p>Removed topic "Installing Float Module Top Cover (Parts Bag MD #357511)" because that is for headers sold outside of North America.</p>	Technical Publications
—	<p>Removed duplicate procedure 7.2 Checking and Adjusting Reel Fore-Aft Position Sensor, page 262 from the pre-delivery chapter because that procedure is already included in the chapter that precedes the auto header height control chapter.</p>	Technical Publications
6.1 Checking Tire Pressure – Option for D230 and D235, page 203	<p>Changed the load range from "E" to "F", and the pressure from 552 kPa (80 psi) to 655 kPa (95 psi).</p>	ECN 62597
6.3 Checking Oil Level in Knife Drive Box, page 205	<p>Corrected the steps for checking the oil level.</p>	Product Support
6.9 Reel-to-Cutterbar Clearance, page 224	<p>Revised as follows:</p> <ul style="list-style-type: none"> • D225 - "end panels" changed from 25 mm to 30 mm. • D230 and D235 - "end panels" and "beside center arm" changed from 20 mm to 25 mm. • Removed D241 and D245 because those models are not offered in North America. 	Engineering
6.10 Checking and Adjusting Header Float, page 229	<ul style="list-style-type: none"> • Added step for checking that the header is on down stops. • Updated float indicator illustrations and associated steps to show the new float-check mechanism and the zero "dot". 	Product Support ECN 64338 ECN 64232

Section	Summary of Change	Internal Use Only
<i>6.13 Checking and Adjusting Draper Seal, page 240</i>	<ul style="list-style-type: none"> Added bystander hazard. Removed models D241 and D245 because they are not offered in North America. 	Technical Publications
<i>6.14.2 Lubrication Points, page 245</i>	<ul style="list-style-type: none"> Updated pictures of the feed deck draper drive roller and idler roller to show the model year 2024 assemblies. Removed the three-piece upper cross auger (UCA) because the associated size of header is not available for North America. 	ECN 63641 Technical Publications
<i>7.1 Checking and Adjusting Reel Height Sensor, page 259</i>	<ul style="list-style-type: none"> Moved procedure to precede the auto header height control chapter. Added Challenger®, Gleaner®, Massey Ferguson®, and Rostselmash information to the voltage limits table. 	Technical Publications Engineering
<i>7.2 Checking and Adjusting Reel Fore-Aft Position Sensor, page 262</i>	<ul style="list-style-type: none"> Moved procedure to precede the auto header height control chapter. Updated all fore-aft sensor illustrations and associated steps for model year 2024. 	Technical Publications ECN 64090 ECN 65011
<i>8.1.2 Recommended Sensor Output Voltages for Combines, page 268</i>	<ul style="list-style-type: none"> Removed all combine model numbers because this was unnecessary detail. Added Rostselmash. 	Engineering
<i>8.1.3 Manually Checking Voltage Limits, page 269</i>	<ul style="list-style-type: none"> Updated float indicator illustrations and associated steps to show the new float-check mechanism and the zero “dot”. Revised the note about connector P600 to mention all plugs offered for model year 2024. Revised the procedure so that the sensor connectors P537 and P539 are tested instead of P600. 	ECN 64338 ECN 64232 ECN 63849 Product Support Engineering
—	Deleted the topic “Replacing Float Height Sensor”.	Product Support
<i>Checking Voltage Range from Combine Cab – Case IH 5130, 5140, 6130, 6140, 7130, and 7140, page 274</i>	<ul style="list-style-type: none"> Revised the introductory steps for consistency with equivalent procedures for other brands of combine. Updated float indicator illustrations and associated steps to show the new float-check mechanism and the zero “dot”. Added last step “If the sensor voltage is not within the lower and upper limits...” for consistency with equivalent procedures for other brands of combine. 	ECN 64338 ECN 64232 Technical Publications
<i>Header Settings Quick Reference – Case IH 130 and 140 Series, page 276</i>	Added topic.	Technical Publications

Section	Summary of Change	Internal Use Only
<i>Calibrating Auto Header Height Control – Case IH 5130, 5140, 6130, 6140, 7130, and 7140 Combines with Software Version below 28.00, page 279</i>	Revised the introductory steps for consistency with equivalent procedures for other brands of combine.	Technical Publications
<i>Setting Preset Cutting Height – Case IH 5130, 5140, 6130, 6140, 7130, and 7140, page 281</i>	Updated float indicator illustration to show the new float-check mechanism.	ECN 64338
<i>Checking Voltage Range from Combine Cab – Case IH, 120, 230, 240, and 250 Series Combines, page 284</i>	<ul style="list-style-type: none"> • Revised the introductory steps for consistency with equivalent procedures for other brands of combine. • Updated float indicator illustrations and associated steps to show the new float-check mechanism and the zero “dot”. • Added last step “If the sensor voltage is not within the lower and upper limits...” for consistency with equivalent procedures for other brands of combine. 	ECN 64338 ECN 64232 Technical Publications
<i>Header Settings Quick Reference – Case IH 120, 230, 240, and 250 Series, page 286</i>	Added topic.	Technical Publications
<i>Calibrating Auto Header Height Control – Case IH 120, 230, 240, and 250 Series Combines with Software Version below 28.00, page 287</i>	<ul style="list-style-type: none"> • Revised the introductory steps for consistency with equivalent procedures for other brands of combine. • Illustration 1042851 replaces 1025903 to show the “Rigid” value for the header style field. 	Product Support Technical Publications
<i>Calibrating Auto Header Height Control – Case IH Combines with Version 28.00 or Higher Software, page 292</i>	<ul style="list-style-type: none"> • Revised the introductory steps for consistency with equivalent procedures for other brands of combine. • Updated illustrations to include new “FD2/D2 Series” value for the “Header Sub Type” field. 	Engineering Technical Publications
<i>Setting Preset Cutting Height – Case IH 120, 230, 240, and 250 Series Combines, page 299</i>	Updated float indicator illustration to show the new float-check mechanism.	ECN 64338
<i>Reel Reverse Function – Case IH Combines, page 300</i>	Added topic.	Engineering
<i>Side Draper Speed Control – Case IH Combines, page 303</i>	Added topic.	Engineering
<i>Reel Speed Sensor Compatibility – Case IH Combines, page 305</i>	Added topic.	Engineering
<i>Checking Voltage Range from Combine Cab – Challenger® and Massey Ferguson®, page 306</i>	<ul style="list-style-type: none"> • Revised the introductory steps for consistency with equivalent procedures for other brands of combine. • Updated float indicator illustrations and associated steps to show the new float-check mechanism and the zero “dot”. 	ECN 64338 ECN 64232

Section	Summary of Change	Internal Use Only
<i>Calibrating Auto Header Height Control – Challenger® and Massey Ferguson®, page 309</i>	Revised the introductory steps for consistency with equivalent procedures for other brands of combine.	Technical Publications
—	All procedures previously labeled “CLAAS 500 Series” are now labeled “CLAAS Lexion 500 Series”.	Engineering
<i>Calibrating Auto Header Height Control – CLAAS Lexion 500 Series, page 315</i>	<ul style="list-style-type: none"> Revised the introductory steps for consistency with equivalent procedures for other brands of combine. Deleted "link limiter" content as it does not apply to this model of combine. 	Technical Publications
—	All procedures previously labeled “CLAAS 600 and 700 Series” are now labeled “CLAAS Lexion 600 and 700 Series”.	Engineering
<i>Calibrating Reel Height Sensor and Reel Fore-Aft Sensor – CLAAS Lexion 600 and 700 Series, page 333</i>	Added illustration 1043654 and revised the NOTE to refer to headers as “integration-equipped” instead of headers equipped with bundle B7231.	ECN 62841
<i>Calibrating Auto Header Height Control – CLAAS Lexion 600 and 700 Series, page 326</i>	<ul style="list-style-type: none"> Revised the introductory steps for consistency with equivalent procedures for other brands of combine. Deleted "link limiter" content as it does not apply to this model of combine. 	Technical Publications
—	All procedures previously labeled “CLAAS 7000 and 8000 Series” are now labeled “CLAAS Lexion 5/6/7/8000 and TRION Series”.	Engineering
<i>Calibrating Auto Header Height Control – CLAAS Lexion 5/6/7/8000 Series and TRION Series, page 340</i>	<ul style="list-style-type: none"> Revised the introductory steps for consistency with equivalent procedures for other brands of combine. Deleted "link limiter" content as it does not apply to this model of combine. 	Technical Publications
<i>Calibrating Reel Height Sensor and Reel Fore-Aft Sensor – CLAAS Lexion 5/6/7/8000 Series and TRION Series, page 347</i>	Added illustration 1043654 and revised the NOTE to refer to headers as “integration-equipped” instead of headers equipped with bundle B7231.	ECN 62841
<i>Checking Voltage Range from Combine Cab – Gleaner® R65, R66, R75, R76, and Pre-2016 S Series, page 350</i>	<ul style="list-style-type: none"> Revised the introductory steps for consistency with equivalent procedures for other brands of combine. Updated float indicator illustrations and associated steps to show the new float-check mechanism and the zero “dot”. Added last step “If the sensor voltage is not within the lower and upper limits...” for consistency with equivalent procedures for other brands of combine. 	ECN 64338 ECN 64232 Technical Publications
<i>Calibrating Auto Header Height Control – Gleaner® R65, R66, R75, R76, and Pre-2016 S Series, page 353</i>	Revised the introductory steps for consistency with equivalent procedures for other brands of combine.	Technical Publications

Section	Summary of Change	Internal Use Only
<i>Adjusting Ground Pressure – Gleaner® R65, R66, R75, R76, and Pre-2016 S Series, page 358</i>	Updated float indicator illustration to show the new float check mechanism	ECN 64338
<i>Calibrating Auto Header Height Control – Gleaner® S9 Series, page 371</i>	Revised the introductory steps for consistency with equivalent procedures for other brands of combine.	Technical Publications
<i>Header Settings Quick Reference – IDEAL™ Series, page 379</i>	Added topic.	Technical Publications
<i>Calibrating Header – IDEAL™ Series, page 388</i>	Revised the introductory steps for consistency with equivalent procedures for other brands of combine.	Technical Publications
<i>8.1.14 John Deere 60 Series Combines, page 395</i>	Added topic.	Engineering
<i>Checking Voltage Range from Combine Cab – John Deere 60 Series, page 395</i>	Added topic.	Engineering
<i>Calibrating Auto Header Height Control – John Deere 60 Series, page 397</i>	Added topic.	Engineering
<i>Turning Accumulator Off – John Deere 60 Series, page 399</i>	Added topic.	Engineering
<i>Setting Header Height Sensitivity – John Deere 60 Series, page 400</i>	Added topic.	Engineering
<i>Setting Auto Header Height Control Sensitivity – John Deere 60 Series, page 401</i>	Added topic.	Engineering
<i>Adjusting Drop Rate Valve Threshold – John Deere 60 Series, page 402</i>	Added topic.	Engineering
<i>Checking Voltage Range from Combine Cab – John Deere 70 Series, page 403</i>	<ul style="list-style-type: none"> Revised the introductory steps for consistency with equivalent procedures for other brands of combine. Updated float indicator illustrations and associated steps to show the new float-check mechanism and the zero “dot”. Added last step “If the sensor voltage is not within the lower and upper limits...” for consistency with equivalent procedures for other brands of combine. 	ECN 64338 ECN 64232 Technical Publications
<i>Calibrating Auto Header Height Control – John Deere 70 Series, page 407</i>	Revised the introductory steps for consistency with equivalent procedures for other brands of combine.	Technical Publications

Section	Summary of Change	Internal Use Only
<i>Checking Voltage Range from Combine Cab – John Deere S and T Series, page 410</i>	<ul style="list-style-type: none"> • Revised the introductory steps for consistency with equivalent procedures for other brands of combine. • Updated float indicator illustrations and associated steps to show the new float-check mechanism and the zero “dot”. • Added last step “If the sensor voltage is not within the lower and upper limits...” for consistency with equivalent procedures for other brands of combine. 	ECN 64338 ECN 64232 Technical Publications
<i>Adjusting Manual Header Raise/Lower Rate – John Deere S and T Series, page 413</i>	Updated float indicator illustration to show the new float-check mechanism.	ECN 64338
<i>Calibrating Auto Header Height Control – John Deere S and T Series, page 415</i>	Revised the introductory steps for consistency with equivalent procedures for other brands of combine.	Technical Publications
<i>Setting Preset Cutting Height – John Deere S and T Series, page 420</i>	Updated float indicator illustration to show the new float-check mechanism.	ECN 64338
<i>Checking Voltage Range from Combine Cab – John Deere S7 Series, page 434</i>	<ul style="list-style-type: none"> • Revised the introductory steps for consistency with equivalent procedures for other brands of combine. • Updated float indicator illustrations and associated steps to show the new float-check mechanism and the zero “dot”. • Added last step “If the sensor voltage is not within the lower and upper limits...” for consistency with equivalent procedures for other brands of combine. 	ECN 64338 ECN 64232 Technical Publications
<i>Calibrating Header – John Deere S7 Series, page 440</i>	Revised the introductory steps for consistency with equivalent procedures for other brands of combine.	Technical Publications
<i>Calibrating Auto Header Height Control – John Deere X9 Series, page 446</i>	<ul style="list-style-type: none"> • Revised the introductory steps for consistency with equivalent procedures for other brands of combine. • Clarified how to calibrate the header. 	Technical Publications ECN 64318
<i>Checking Voltage Range from Combine Cab – John Deere X9 Series, page 449</i>	<ul style="list-style-type: none"> • Revised the introductory steps for consistency with equivalent procedures for other brands of combine. • Added last step “If the sensor voltage is not within the lower and upper limits...” for consistency with equivalent procedures for other brands of combine. 	Technical Publications
<i>Using Auto Header Height Control – John Deere X9 Series, page 452</i>	Removed the step that mentioned ContourMax™ because that option is not offered for the header.	Technical Publications

Section	Summary of Change	Internal Use Only
—	Deleted the following topics because the option is not offered for the header: <ul style="list-style-type: none"> • “Cutting Above Ground Level – Headers Equipped with ContourMax™” • “Cutting at Ground Level – Headers Equipped with ContourMax™” 	Technical Publications
<i>Reel Reverse Function – John Deere X9 Series, page 456</i>	Added topic.	ECN 64758
—	Removed the following John Deere X9 topics: <ul style="list-style-type: none"> • Assigning Multi-Function Lever Buttons – John Deere X9 Series • Assigning Console Buttons – John Deere X9 Series 	Technical Publications
<i>Checking Voltage Range from Combine Cab – New Holland CR and CX Series, page 458</i>	<ul style="list-style-type: none"> • Revised the introductory steps for consistency with equivalent procedures for other brands of combine. • Updated float indicator illustrations and associated steps to show the new float-check mechanism and the zero “dot”. • Added last step “If the sensor voltage is not within the lower and upper limits...” for consistency with equivalent procedures for other brands of combine. 	ECN 64338 ECN 64232 Technical Publications
<i>Calibrating Auto Header Height Control – New Holland CR and CX Series, page 462</i>	Revised the introductory steps for consistency with equivalent procedures for other brands of combine.	Technical Publications
<i>Setting Preset Cutting Height – New Holland CR and CX Series, page 467</i>	Updated float indicator illustration to show the new float-check mechanism.	ECN 64338
<i>8.1.20 New Holland Combines – CR Series (2015 and Later) and CH, page 469</i>	Added New Holland combine CH.	ECN 64037
<i>Checking Voltage Range from Combine Cab – New Holland CR Series and CH, page 469</i>	<ul style="list-style-type: none"> • Revised the introductory steps for consistency with equivalent procedures for other brands of combine. • Added New Holland combine CH. • Updated float indicator illustrations and associated steps to show the new float-check mechanism and the zero “dot”. • Added last step “If the sensor voltage is not within the lower and upper limits...” for consistency with equivalent procedures for other brands of combine. 	ECN 64037 ECN 64338 ECN 64232 Technical Publications
<i>Setting up Auto Header Height Control – New Holland CR Series and CH, page 472</i>	<ul style="list-style-type: none"> • Added New Holland combine CH. • Removed instructions for accessing dealer mode. 	ECN 64037 Engineering

Section	Summary of Change	Internal Use Only
<i>Setting up Reel Speed – New Holland CR Series and CH, page 475</i>	Added New Holland combine CH. <ul style="list-style-type: none"> Added New Holland combine CH. Removed instructions for accessing dealer mode. 	ECN 64037 Engineering
<i>Calibrating Auto Header Height Control – New Holland CR Series and CH, page 476</i>	Added New Holland combine CH.	ECN 64037
<i>Calibrating Reel Height Sensor and Reel Fore-Aft Sensor – New Holland CR Series and CH, page 479</i>	Added New Holland combine CH.	ECN 64037
<i>Checking Reel Height Sensor Voltages – New Holland CR Series and CH, page 482</i>	<ul style="list-style-type: none"> Added New Holland combine CH. Corrected the voltage ranges and associated steps. 	Product Support
<i>Setting Preset Cutting Height – New Holland CR Series and CH, page 483</i>	Added New Holland combine CH.	ECN 64037
<i>Setting Maximum Work Height – New Holland CR Series and CH, page 485</i>	Added New Holland combine CH.	ECN 64037
<i>Configuring Reel Fore-Aft, Header Tilt, and Header Type – New Holland CR Series and CH, page 487</i>	<ul style="list-style-type: none"> Added New Holland combine CH. Removed instructions for accessing dealer mode. 	ECN 64037 Engineering
<i>Reel Reverse Function – New Holland CR Series and CH, page 488</i>	Added topic.	Engineering
<i>8.1.21 Rostselmash Combines – RSM 161, T500, and TORUM 785, page 491</i>	Corrected model numbers in the title.	Engineering
<i>Calibrating Auto Header Height Control – Rostselmash RSM 161, T500, and TORUM 785, page 491</i>	Updated float indicator illustration to show the new float-check mechanism.	ECN 64338
<i>Engaging Auto Header Height Control – Rostselmash RSM 161, T500, and TORUM 785, page 493</i>	Corrected model numbers in the title.	Engineering
<i>Calibrating Reel Speed – Rostselmash RSM 161, T500, and TORUM 785, page 494</i>	Corrected model numbers in the title.	Engineering
<i>Operating Header – Rostselmash RSM 161, T500, and TORUM 785, page 496</i>	Corrected model numbers in the title.	Engineering
<i>9 Running up Header, page 499</i>	The step “Engage the header with the combine running at low idle” previously used the term “low rpm”.	Product Support
<i>9.1 Adjusting Side Draper Speed, page 501</i>	Added topic.	Technical Publications
—	Removed procedure “Checking Knife Speed” because this information is contained in <i>9.2 Checking and Adjusting Knife Speed – Dynamatic Integrated Pump (MD #337774), page 503.</i>	Technical Publications
<i>9.2 Checking and Adjusting Knife Speed – Dynamatic Integrated Pump (MD #337774), page 503</i>	<ul style="list-style-type: none"> Reordered most steps. Added Rostselmash to the “Feeder House Speed” table. 	Product Support Engineering

Section	Summary of Change	Internal Use Only
<i>10.5 Leveling Header, page 526</i>	Added topic.	Product Support
<i>10.1 Changing Float Spring Configuration and Installation Location, page 511</i>	Added topic.	Product Support
<i>10.6.4 O-Ring Boss Hydraulic Fittings – Non-Adjustable, page 533</i>	Updated torque values in the table.	ECN 64539
<i>10.6.3 O-Ring Boss Hydraulic Fittings – Adjustable, page 532</i>	Updated torque values in the table.	ECN 64539
<i>10.6.5 O-Ring Face Seal Hydraulic Fittings, page 534</i>	Minor corrections in the table of torque values: <ul style="list-style-type: none"> • Size -6: rounded lbf-ft from 29 up to 30. • Size -24: corrected "Thread Size" from 1-2 to 2 	Technical Publications
Inside back cover	Added "Recommended Fluids and Lubricants".	Product Support

TABLE OF CONTENTS

Introduction	i
Summary of Changes.....	ii
Chapter 1: Safety	1
1.1 Safety Alert Symbols	1
1.2 Signal Words	2
1.3 General Safety	3
1.4 Hydraulic Safety	5
1.5 Welding Precautions	6
1.6 Safety Signs	8
Chapter 2: Unloading Header.....	9
2.1 Header Specifications for Unloading and Assembly.....	9
2.2 Unloading Header and Float Module from Trailer – Headers Shipped Flat.....	11
2.3 Unloading Header and Float Module from Trailer – Headers Shipped Upright	13
2.4 Removing Upper Cross Auger from Shipping Location – Option	15
2.5 Removing Parts from Shipping Location.....	16
2.6 Lowering Header to Field Position – D225.....	17
2.7 Lowering Header to Field Position – D230 and D235.....	21
2.8 Removing Crop Dividers From Single Reel Shipping Position, and Installing Deflector Hardware – D225 (Parts Bag MD #357731).....	25
2.9 Removing Crop Dividers From Double Reel Shipping Position – D230 and D235.....	27
2.10 Removing Shipping Stands and Supports – D225	28
2.11 Removing Shipping Stands – D230 and D235	31
2.12 Removing Anti-Rotation Strap from Reel and Installing Knife Cover Hardware – D225, D230, and D235 (Parts Bag MD #347598).....	33
Chapter 3: Setting up Float Module.....	35
3.1 Repositioning Completion Gearbox to Working Position	35
3.2 Installing Standard Driveline (B7038, B7039, or B7108)	37
3.3 Installing Driveline for Combines Equipped with a Slope Compensation Package (B7180, B7181, B7182, or B7326).....	41
3.4 Installing Filler Cap (Unmarked Parts Bag).....	46
3.5 Installing Cab Control Kits (Parts Bags MD #337619 or 337627)	47
3.6 Retrieving Limiter Link – CLAAS Lexion Combines	48
3.7 Retrieving Two-Position Adjustment Plates – John Deere X9 Series Combines	49
Chapter 4: Attaching Header to Combine	51
4.1 Attaching Header to Case IH Combine	52
4.2 Attaching Header to Challenger®, Gleaner®, or Massey Ferguson® Combine.....	57
4.3 Attaching Header to CLAAS Combine	62

TABLE OF CONTENTS

4.3.1 Installing Limiter Link and Performing a Fore/Aft Tilt Calibration – CLAAS Lexion 5/6/7/8000 Series and TRION Series	67
4.4 Attaching Header to IDEAL™ Series Combine.....	72
4.5 Attaching Header to John Deere Combine.....	76
4.6 Attaching Header to New Holland CR, CX, or CH Combine.....	84
4.7 Attaching Header to Rostselmash Combine	89
Chapter 5: Completing Header Assembly.....	93
5.1 Installing Center-Link Cylinder (Parts Bag MD #347601).....	93
5.2 Removing Shipping Supports	97
5.3 Installing Fore-Aft Indicator and Sensor Spring (Parts Bag MD #368002).....	98
5.4 Installing Front Support for Right Endshield – D225 (Parts Bag MD #357468)	100
5.5 Installing Reel Lift Cylinders – Single Reel, D225	101
5.6 Installing Reel Lift Cylinders – Double Reel, D230 and D235	106
5.7 Installing Deck Cutterbar Seals – D230 (Parts Bag MD #335987).....	113
5.8 Installing Deck Cutterbar Seal – D235 (Parts Bag MD #335988).....	116
5.9 Installing Knifehead Guard Hardware (Parts Bag MD #347581)	119
5.10 Installing Skid Shoes – D225 (Parts Bag MD #357993).....	121
5.11 Attaching Reel Height Sensor	124
5.12 Installing Reel Fore-Aft Steel Lines (Parts Bag MD #357107)	127
5.13 Preparing Hydraulic Hoses.....	129
5.14 Connecting Reel to Fore-Aft Cylinders, Single-Reel Headers – D225 (Parts Bag MD #357467)	130
5.15 Connecting Reel to Fore-Aft Cylinders – Double-Reel Headers D230 and D235 (Parts Bag MD #347580)	136
5.16 Installing Reel Fore-Aft Hose Clamp – D230 and D235	142
5.17 Installing Tine Tubes and Cam Control Linkages.....	143
5.17.1 Installing Tine Tube onto Reel – D225 (Parts Bag MD #357394)	143
5.17.2 Attaching Cam Control Linkages to Tine Tubes – D225 (Parts Bag MD #357743)	148
5.17.3 Connecting Cam Control Linkages to Tine Tube Cranks – D230 and D235 (Parts Bag MD #347627)	149
5.18 Installing Single-Reel Endshields, Nine-Bat – D225 (Parts Bag MD #368328)	150
5.18.1 Installing Single-Reel Endshields at Cam End – Nine-Bat	151
5.18.2 Installing Single-Reel Endshields at Tail End – Nine-Bat	158
5.19 Installing Double-Reel Endshields – Parts Bag MD #368322 (Five-Bat Reels) or MD #368323 (Six-Bat Reels).....	165
5.19.1 Installing Double-Reel Endshields at Outboard Cam End.....	166
5.19.2 Installing Double-Reel Endshields at Inboard Tail End	174
5.19.3 Installing Double-Reel Endshields at Inboard Cam End	181
5.19.4 Installing Double-Reel Endshields at Outboard Tail End	188
5.20 Installing Tank Covers (Parts Bag MD #357088)	195
5.21 Installing Clearance Lights	196
5.22 Crop Dividers	198

TABLE OF CONTENTS

5.22.1 Installing Crop Dividers.....	198
5.22.2 Installing Crop Divider Rods.....	200
5.23 Installing Options.....	201
Chapter 6: Performing Predelivery Checks.....	203
6.1 Checking Tire Pressure – Option for D230 and D235	203
6.2 Checking Transport Wheel Bolt Torque – Option for D230 and D235	204
6.3 Checking Oil Level in Knife Drive Box.....	205
6.4 Checking Oil Level in Header Drive Main Gearbox	206
6.5 Checking Oil Level in Header Drive Completion Gearbox.....	207
6.6 Checking Oil Level in Hydraulic Reservoir	208
6.7 Guard Identification	209
6.7.1 Checking Hold-Down – Pointed Knife Guards	211
6.7.2 Adjusting Hold-Down – Pointed Knife Guards.....	212
6.7.3 Checking Center Hold-Down on Double-Knife Header – Pointed Knife Guards.....	213
6.7.4 Adjusting Center Hold-Down on Double-Knife Header – Pointed Knife Guards	214
6.7.5 Checking Hold-Down – Short Knife Guards	215
6.7.6 Adjusting Hold-Down – Short Knife Guards.....	215
6.7.7 Checking Center Hold-Down on Double-Knife Headers – Short Knife Guards.....	216
6.7.8 Adjusting Center Hold-Down – Short Knife Guards	217
6.7.9 Adjusting Knife Guards and Guard Bar	218
6.8 Checking and Adjusting Reel-to-Endsheet Clearance	221
6.9 Reel-to-Cutterbar Clearance	224
6.9.1 Measuring Reel-to-Cutterbar Clearance	224
6.9.2 Adjusting Reel-to-Cutterbar Clearance	226
6.10 Checking and Adjusting Header Float	229
6.11 Adjusting Feed-Auger-to-Pan Clearance	235
6.12 Checking and Adjusting Side Draper Tension.....	238
6.13 Checking and Adjusting Draper Seal	240
6.14 Lubricating Header.....	243
6.14.1 Greasing Procedure	243
6.14.2 Lubrication Points	245
6.15 Checking and Adjusting Header Endshields.....	253
6.16 Checking Manuals.....	258
Chapter 7: Setting up Reel Position Sensors	259
7.1 Checking and Adjusting Reel Height Sensor	259
7.2 Checking and Adjusting Reel Fore-Aft Position Sensor	262
Chapter 8: Setting Up Auto Header Height Control System.....	265
8.1 Auto Header Height Control System.....	265
8.1.1 Auto Header Height Control Sensor Operation	266

TABLE OF CONTENTS

8.1.2 Recommended Sensor Output Voltages for Combines	268
8.1.3 Manually Checking Voltage Limits	269
8.1.4 10 Volt Adapter – New Holland Combines Only	273
8.1.5 Case IH 130 and 140 Series Mid-Range Combines	274
Checking Voltage Range from Combine Cab – Case IH 5130, 5140, 6130, 6140, 7130, and 7140	274
Header Settings Quick Reference – Case IH 130 and 140 Series.....	276
Setting up Header on Combine Display – Case IH 5130, 5140, 6130, 6140, 7130, and 7140	277
Calibrating Auto Header Height Control – Case IH 5130, 5140, 6130, 6140, 7130, and 7140 Combines with Software Version below 28.00	279
Setting Preset Cutting Height – Case IH 5130, 5140, 6130, 6140, 7130, and 7140	281
8.1.6 Case IH 120, 230, 240, and 250 Series Combines	284
Checking Voltage Range from Combine Cab – Case IH, 120, 230, 240, and 250 Series Combines	284
Header Settings Quick Reference – Case IH 120, 230, 240, and 250 Series	286
Calibrating Auto Header Height Control – Case IH 120, 230, 240, and 250 Series Combines with Software Version below 28.00	287
Calibrating Auto Header Height Control – Case IH Combines with Version 28.00 or Higher Software	292
Checking Reel Height Sensor Voltages – Case IH Combines	298
Setting Preset Cutting Height – Case IH 120, 230, 240, and 250 Series Combines	299
Reel Reverse Function – Case IH Combines.....	300
Side Draper Speed Control – Case IH Combines.....	303
Reel Speed Sensor Compatibility – Case IH Combines.....	305
8.1.7 Challenger® and Massey Ferguson® 6 and 7 Series Combines	306
Checking Voltage Range from Combine Cab – Challenger® and Massey Ferguson®	306
Engaging Auto Header Height Control – Challenger® and Massey Ferguson®	308
Calibrating Auto Header Height Control – Challenger® and Massey Ferguson®.....	309
Adjusting Header Height – Challenger® and Massey Ferguson®.....	312
Adjusting Header Raise/Lower Rate – Challenger® and Massey Ferguson®	313
Setting Auto Header Height Control Sensitivity – Challenger® and Massey Ferguson®	314
8.1.8 CLAAS Lexion 500 Series Combines	315
Calibrating Auto Header Height Control – CLAAS Lexion 500 Series.....	315
Cutting Height – CLAAS Lexion 500 Series	318
Setting Auto Header Height Control Sensitivity – CLAAS Lexion 500 Series	320
Adjusting Auto Reel Speed – CLAAS Lexion 500 Series	323
8.1.9 CLAAS Lexion 600 and 700 Series Combines.....	326
Calibrating Auto Header Height Control – CLAAS Lexion 600 and 700 Series.....	326
Setting Cutting Height – CLAAS Lexion 600 and 700 Series	330
Setting Auto Header Height Control Sensitivity – CLAAS Lexion 600 and 700 Series	330
Adjusting Auto Reel Speed – CLAAS Lexion 600 and 700 Series	332
Calibrating Reel Height Sensor and Reel Fore-Aft Sensor – CLAAS Lexion 600 and 700 Series	333
Adjusting Auto Reel Height – CLAAS Lexion 600 and 700 Series.....	337
8.1.10 CLAAS Lexion 5/6/7/8000 Series and TRION Series Combines.....	338
Header Settings Quick Reference – CLAAS Lexion 5/6/7/8000 Series and TRION Series	338
Setting up Header – CLAAS Lexion 5/6/7/8000 Series and TRION Series.....	339
Calibrating Auto Header Height Control – CLAAS Lexion 5/6/7/8000 Series and TRION Series.....	340
Setting Cut and Reel Height Preset – CLAAS Lexion 5/6/7/8000 Series and TRION Series	343
Setting Auto Header Height Control Sensitivity – CLAAS Lexion 5/6/7/8000 Series and TRION Series.....	344
Adjusting Auto Reel Speed – CLAAS Lexion 5/6/7/8000 Series and TRION Series	346
Calibrating Reel Height Sensor and Reel Fore-Aft Sensor – CLAAS Lexion 5/6/7/8000 Series and TRION Series.....	347
8.1.11 Gleaner® R65, R66, R75, R76, and S Series Combines	350

TABLE OF CONTENTS

Checking Voltage Range from Combine Cab – Gleaner® R65, R66, R75, R76, and Pre-2016 S Series.....	350
Engaging Auto Header Height Control – Gleaner® R65, R66, R75, R76, and Pre-2016 S Series	352
Calibrating Auto Header Height Control – Gleaner® R65, R66, R75, R76, and Pre-2016 S Series	353
Turning off Accumulator – Gleaner® R65, R66, R75, R76, and Pre-2016 S Series	357
Adjusting Header Raise/Lower Rate – Gleaner® R65, R66, R75, R76, and Pre-2016 S Series	358
Adjusting Ground Pressure – Gleaner® R65, R66, R75, R76, and Pre-2016 S Series	358
Adjusting Auto Header Height Control Sensitivity – Gleaner® R65, R66, R75, R76, and Pre-2016 S Series.....	359
Troubleshooting Alarms and Diagnostic Faults – Gleaner® R65, R66, R75, R76, and Pre-2016 S Series.....	360
8.1.12 Gleaner® S9 Series Combines	362
Setting up Header – Gleaner® S9 Series.....	362
Setting Minimum Reel Speed and Calibrating Reel – Gleaner® S9 Series.....	367
Setting up Automatic Header Controls – Gleaner® S9 Series	369
Calibrating Auto Header Height Control – Gleaner® S9 Series.....	371
Operating Auto Header Height Control – Gleaner® S9 Series.....	376
Reviewing Header In-Field Settings – Gleaner® S9 Series	377
Header Settings Quick Reference – Gleaner® S9 Series.....	379
8.1.13 IDEAL™ Series Combines	379
Header Settings Quick Reference – IDEAL™ Series	379
Setting up Header – IDEAL™ Series	380
Setting Minimum Reel Speed and Calibrating Reel – IDEAL™ Series	385
Setting up Automatic Header Controls – IDEAL™ Series	387
Calibrating Header – IDEAL™ Series	388
Operating Header – IDEAL™ Series	392
Reviewing Header In-Field Settings – IDEAL™ Series	393
8.1.14 John Deere 60 Series Combines	395
Checking Voltage Range from Combine Cab – John Deere 60 Series.....	395
Calibrating Auto Header Height Control – John Deere 60 Series	397
Turning Accumulator Off – John Deere 60 Series.....	399
Setting Header Height Sensitivity – John Deere 60 Series.....	400
Setting Auto Header Height Control Sensitivity – John Deere 60 Series.....	401
Adjusting Drop Rate Valve Threshold – John Deere 60 Series.....	402
8.1.15 John Deere 70 Series Combines	403
Checking Voltage Range from Combine Cab – John Deere 70 Series.....	403
Calibrating Feeder House Speed – John Deere 70 Series	406
Adjusting Manual Header Raise/Lower Rate – John Deere 70 Series	406
Calibrating Auto Header Height Control – John Deere 70 Series	407
Setting Auto Header Height Control Sensitivity – John Deere 70 Series.....	409
8.1.16 John Deere S and T Series Combines.....	410
Checking Voltage Range from Combine Cab – John Deere S and T Series	410
Adjusting Manual Header Raise/Lower Rate – John Deere S and T Series.....	413
Calibrating Auto Header Height Control – John Deere S and T Series.....	415
Setting Auto Header Height Control Sensitivity – John Deere S and T Series	419
Setting Preset Cutting Height – John Deere S and T Series.....	420
Calibrating Feeder House Fore-Aft Tilt Range – John Deere S and T Series	423
Checking Reel Height Sensor Voltages – John Deere S and T Series.....	425
Calibrating Reel Height Sensor and Reel Fore-Aft Sensor – John Deere S and T Series	428
8.1.17 John Deere S7 Series Combines	430
Setting up Header – John Deere S7 Series	430
Checking Voltage Range from Combine Cab – John Deere S7 Series.....	434
Calibrating Feeder House – John Deere S7 Series	437

TABLE OF CONTENTS

Calibrating Header – John Deere S7 Series	440
8.1.18 John Deere X9 Series Combines	444
Setting up Header in CommandCenter™ Display – John Deere X9 Series.....	444
Calibrating Auto Header Height Control – John Deere X9 Series	446
Checking Voltage Range from Combine Cab – John Deere X9 Series.....	449
Using Auto Header Height Control – John Deere X9 Series	452
Checking Error Codes on Header Controller – John Deere X9 Series	454
Reel Reverse Function – John Deere X9 Series	456
Checking Software Version of Header Controller – John Deere X9 Series	456
8.1.19 New Holland CR and CX Series Combines – 2014 and Earlier	458
Checking Voltage Range from Combine Cab – New Holland CR and CX Series	458
Header Settings Quick Reference – New Holland CR Series.....	461
Setting up Auto Header Height Control – New Holland CR and CX Series	461
Calibrating Auto Header Height Control – New Holland CR and CX Series.....	462
Calibrating Maximum Stubble Height – New Holland CR and CX Series.....	464
Adjusting Header Raise Rate – New Holland CR and CX Series.....	465
Adjusting Header Lower Rate – New Holland CR and CX Series	466
Setting Auto Header Height Control Sensitivity – New Holland CR and CX Series	467
Setting Preset Cutting Height – New Holland CR and CX Series.....	467
8.1.20 New Holland Combines – CR Series (2015 and Later) and CH	469
Checking Voltage Range from Combine Cab – New Holland CR Series and CH.....	469
Setting up Auto Header Height Control – New Holland CR Series and CH	472
Setting up Reel Speed – New Holland CR Series and CH	475
Calibrating Auto Header Height Control – New Holland CR Series and CH	476
Calibrating Reel Height Sensor and Reel Fore-Aft Sensor – New Holland CR Series and CH.....	479
Checking Reel Height Sensor Voltages – New Holland CR Series and CH	482
Setting Preset Cutting Height – New Holland CR Series and CH	483
Setting Maximum Work Height – New Holland CR Series and CH.....	485
Configuring Reel Fore-Aft, Header Tilt, and Header Type – New Holland CR Series and CH.....	487
Reel Reverse Function – New Holland CR Series and CH	488
8.1.21 Rostselmash Combines – RSM 161, T500, and TORUM 785	491
Calibrating Auto Header Height Control – Rostselmash RSM 161, T500, and TORUM 785	491
Engaging Auto Header Height Control – Rostselmash RSM 161, T500, and TORUM 785.....	493
Calibrating Reel Speed – Rostselmash RSM 161, T500, and TORUM 785	494
Operating Header – Rostselmash RSM 161, T500, and TORUM 785	496
Chapter 9: Running up Header.....	499
9.1 Adjusting Side Draper Speed.....	501
9.2 Checking and Adjusting Knife Speed – Dynamatic Integrated Pump (MD #337774).....	503
9.3 Adjusting Side Draper Tracking	506
9.4 Post Run-Up Adjustments	508
9.4.1 Checking Knife Position	508
9.4.2 Checking and Adjusting Feed Draper Tension	509
Chapter 10: Reference	511
10.1 Changing Float Spring Configuration and Installation Location	511
10.2 Adjusting Side Draper Deck Height.....	517
10.3 Reel Safety Props.....	519
10.3.1 Engaging Reel Safety Props	519
10.3.2 Disengaging Reel Safety Props	520

TABLE OF CONTENTS

10.4 Header Endshields 522
 10.4.1 Opening Header Endshields..... 522
 10.4.2 Closing Header Endshields 523
 10.4.3 Removing Header Endshields 524
 10.4.4 Installing Header Endshields..... 525
10.5 Leveling Header..... 526
10.6 Torque Specifications 529
 10.6.1 Metric Bolt Specifications 529
 10.6.2 Metric Bolt Specifications – Cast Aluminum 531
 10.6.3 O-Ring Boss Hydraulic Fittings – Adjustable..... 532
 10.6.4 O-Ring Boss Hydraulic Fittings – Non-Adjustable 533
 10.6.5 O-Ring Face Seal Hydraulic Fittings 534
 10.6.6 Tapered Pipe Thread Fittings 535
10.7 Conversion Chart 537
10.8 Definitions 538
Predelivery Checklist 541
Recommended Fluids and Lubricants 543

Chapter 1: Safety

Understanding and consistently following these safety procedures will help to ensure the safety of those operating the machine and of bystanders.

1.1 Safety Alert Symbols

The safety alert symbol indicates important safety messages in this manual and on safety signs on the machine.

This symbol means:

- **ATTENTION!**
- **BECOME ALERT!**
- **YOUR SAFETY IS INVOLVED!**

Carefully read and follow the safety message accompanying this symbol.

Why is safety important to you?

- Accidents disable and kill
- Accidents cost
- Accidents can be avoided



Figure 1.1: Safety Symbol

1.2 Signal Words

Three signal words, **DANGER**, **WARNING**, and **CAUTION**, are used to alert you to hazardous situations. Two signal words, **IMPORTANT** and **NOTE**, identify non-safety related information.

Signal words are selected using the following guidelines:

DANGER

Indicates an imminently hazardous situation that, if it is not prevented, will result in death or serious injury.

WARNING

Indicates a potentially hazardous situation that, if it is not prevented, could result in death or serious injury. It may also be used to alert you to unsafe practices.

CAUTION

Indicates a potentially hazardous situation that, if it is not prevented, may result in minor or moderate injury. It may also be used to alert you to unsafe practices.

IMPORTANT:

Indicates a situation that, if not prevented, could result in a malfunction or damage to the machine.

NOTE:

Provides additional information or advice.

1.3 General Safety

Operating, servicing, and assembling machinery presents several safety risks. These risks can be reduced or eliminated by following the relevant safety procedures and wearing the appropriate personal protective equipment.

CAUTION

The following general farm safety precautions should be part of your operating procedure for all types of machinery.

Wear all protective clothing and personal safety devices that could be necessary for the job at hand. Do **NOT** take chances. You may need the following:

- Hard hat
- Protective footwear with slip-resistant soles
- Protective glasses or goggles
- Heavy gloves
- Wet weather gear
- Respirator or filter mask

In addition, take the following precautions:

- Be aware that exposure to loud noises can cause hearing impairment. Wear suitable hearing protection devices such as earmuffs or earplugs to help protect against loud noises.



Figure 1.2: Safety Equipment



Figure 1.3: Safety Equipment

- Provide a first aid kit in case of emergencies.
- Keep a properly maintained fire extinguisher on the machine. Familiarize yourself with its use.
- Keep young children away from machinery at all times.
- Be aware that accidents often happen when Operators are fatigued or in a hurry. Take time to consider the safest way to accomplish a task. **NEVER** ignore the signs of fatigue.

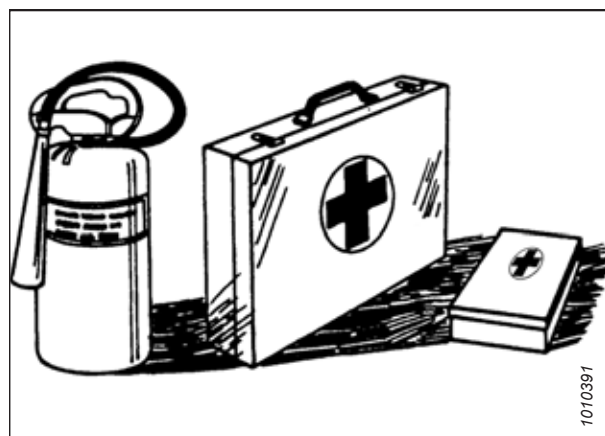

Figure 1.4: Safety Equipment

SAFETY

- Wear close-fitting clothing and cover long hair. **NEVER** wear dangling items such as hoodies, scarves, or bracelets.
- Keep all shields in place. **NEVER** alter or remove safety equipment. Ensure that the driveline guards can rotate independently of their shaft, and that they can telescope freely.
- Use only service and repair parts made or approved by the equipment manufacturer. Parts from other manufacturers may not meet the correct strength, design, or safety requirements.



Figure 1.5: Safety around Equipment

- Keep hands, feet, clothing, and hair away from moving parts. **NEVER** attempt to clear obstructions or objects from a machine while the engine is running.
- Do **NOT** modify the machine. Unauthorized modifications may impair the functionality and/or safety of the machine. It may also shorten the machine's service life.
- To avoid injury or death from the unexpected startup of the machine, **ALWAYS** stop the engine and remove the key from the ignition before leaving the operator's seat for any reason.

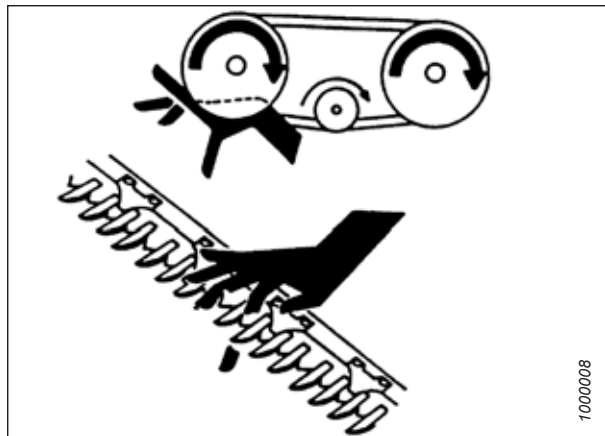

Figure 1.6: Safety around Equipment

- Keep the machine service area clean and dry. Wet and/or oily floors are slippery. Wet spots can be dangerous when working with electrical equipment. Ensure that all electrical outlets and tools are properly grounded.
- Keep the work area well-lit.
- Keep machinery clean. Straw and chaff on a hot engine are fire hazards. Do **NOT** allow oil or grease to accumulate on service platforms, ladders, or controls. Clean machines before they are stored.
- **NEVER** use gasoline, naphtha, or any volatile material for cleaning purposes. These materials may be toxic and/or flammable.
- When storing machinery, cover any sharp or extending components to prevent injury from accidental contact.



Figure 1.7: Safety around Equipment

1.4 Hydraulic Safety

Because hydraulic fluid is under extreme pressure, hydraulic fluid leaks can be very dangerous. Follow the proper safety procedures when inspecting hydraulic fluid leaks and servicing hydraulic equipment.

- Always place all hydraulic controls in **NEUTRAL** before leaving the operator's seat.
- Ensure that all of the components in the hydraulic system are kept clean and in good condition.
- Replace any worn, cut, abraded, flattened, or crimped hoses and steel lines.
- Do **NOT** attempt any makeshift repairs to hydraulic lines, fittings, or hoses by using tapes, clamps, cements, or welding. The hydraulic system operates under extremely high pressure. Makeshift repairs can fail suddenly and create hazardous conditions.



Figure 1.8: Testing for Hydraulic Leaks

- Wear proper hand and eye protection when searching for high-pressure hydraulic fluid leaks. Use a piece of cardboard as a backstop instead of your hands to isolate and identify a leak.
- If you are injured by a concentrated, high-pressure stream of hydraulic fluid, seek medical attention immediately. Serious infection or a toxic reaction can develop from hydraulic fluid piercing the skin.



Figure 1.9: Hydraulic Pressure Hazard

- Ensure that all components are tight and that steel lines, hoses, and couplings are in good condition before applying pressure to a hydraulic system.

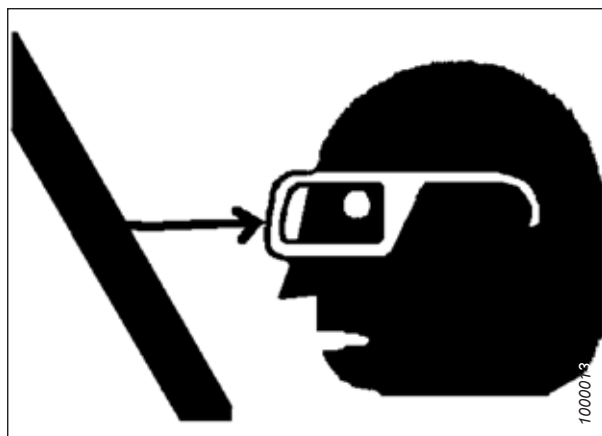

Figure 1.10: Safety around Equipment

1.5 Welding Precautions

To prevent damage to sensitive electronics, **NEVER** attempt welding on the header while it is connected to a combine.

WARNING

NEVER attempt welding on the header while it is connected to a combine. Severe damage to sensitive, expensive electronics can result from welding on the header while it is connected to a combine. It can be impossible to know what effect a high current may have regarding future malfunctions or a shorter lifespan.

For further welding precautions, consult the combine operator's manual.

Before welding on a header, you **MUST** detach the header from the combine, and then disconnect the following electrical components from the header:

Draper Speed Control Module

1. On the FM200 adapter, between the frame and the header, disconnect draper speed control module (A) from solenoid (B).

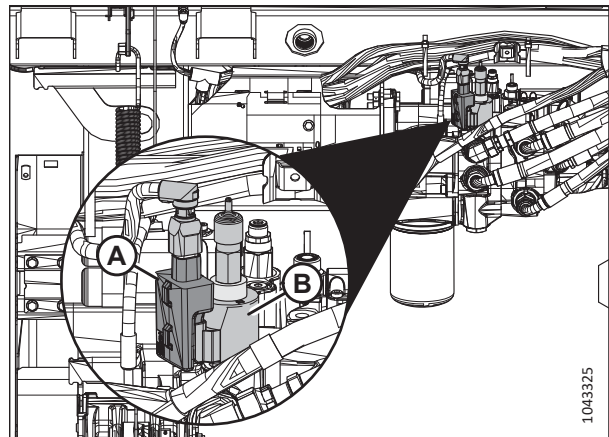

Figure 1.11: Draper Speed Control Module

John Deere X9 Integration Module

2. On the FM200 frame, between the header and the adapter, disconnect John Deere X9 integration module (A) by unplugging bulkhead (B) from the module.

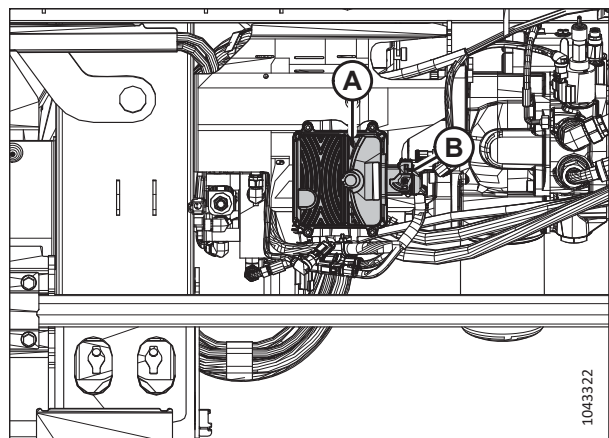

Figure 1.12: John Deere X9 Integration Module

SAFETY

3. To unplug the bulkhead from the module, push in tab (A) to unlatch arm (B).
4. Push arm (B) downward until it is in the position shown. Unplug the bulkhead from the module.

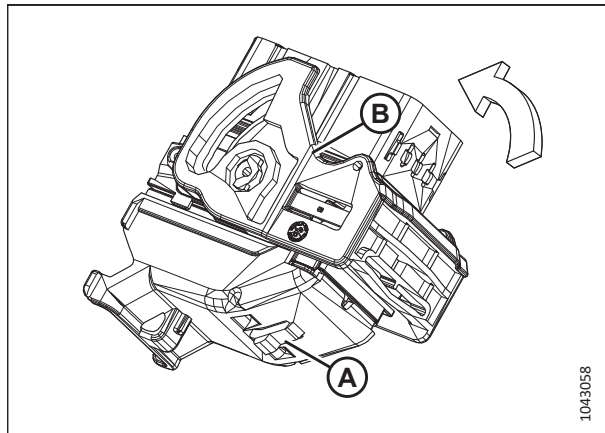

Figure 1.13: Unplugging Bulkhead from Control Module

CLAAS Integration Module

5. On the FM200 frame, between the header and the adapter, disconnect CLAAS integration module (A) by unplugging connector (B).

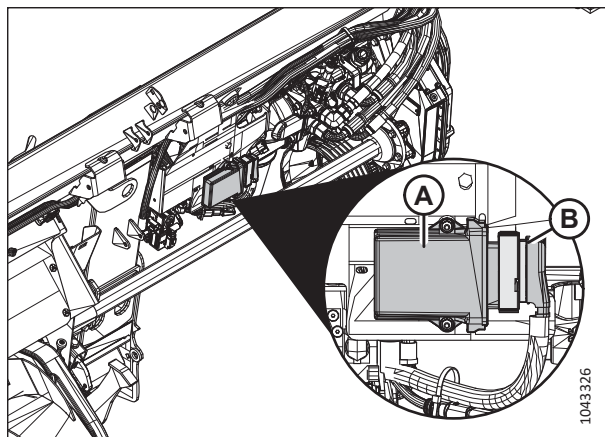

Figure 1.14: CLAAS Integration Module

6. To unplug the connector, use a screwdriver or a pair of needle nose pliers to slowly pull out latch (A) while allowing the connector to back off of the integration module.

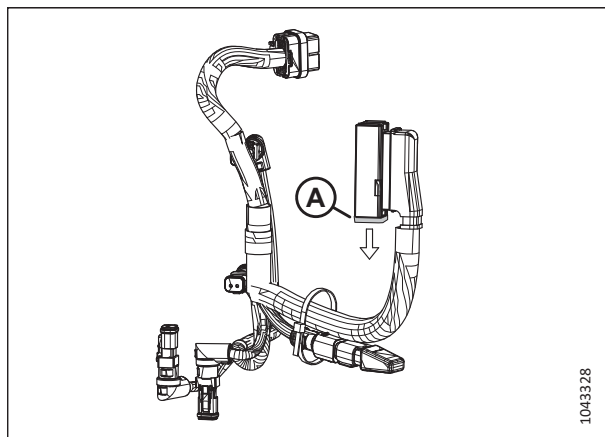

Figure 1.15: CLAAS Integration Harness

1.6 Safety Signs

Safety signs are decals placed on the machine where there is a risk of personal injury, or where the Operator should take extra precautions before operating the controls. They are usually yellow.

- Keep safety signs clean and legible at all times.
- Replace safety signs that are missing or illegible.
- If the original part on which a safety sign was installed is replaced, ensure that the repair part displays the current safety sign.

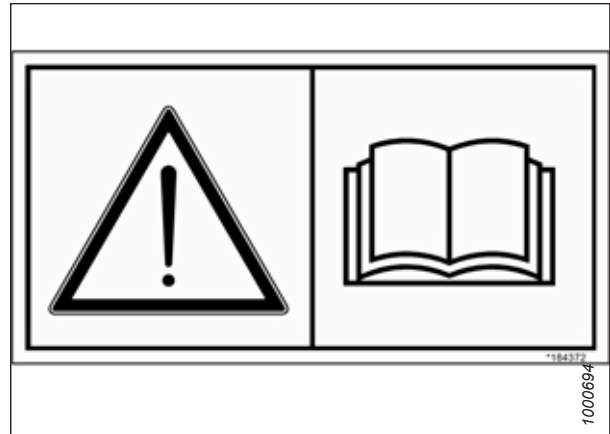

Figure 1.16: Operator's Manual Decal

Chapter 2: Unloading Header

Carefully follow these procedures in the order in which they are presented.

2.1 Header Specifications for Unloading and Assembly

The dimensions, weight, and spreader bar specifications for the header are provided so that you can choose the correct equipment to lift, tip, and transport the header safely.

DANGER

The equipment used for loading or unloading a machine must meet or exceed the requirements specified in this document. Using inadequate equipment may result in chain breakage, vehicle tipping, machine damage or bodily harm to operators or bystanders.

NOTE:

When a header and float module are ordered together, they are shipped with the float module already installed in the header.

To determine the equipment needed to handle the header, refer to the relevant tables below:

- For the header and float module weight specifications, refer to Table 2.1, page 9.
- For the dimensions of fully assembled headers attached to shipping stands, refer to Table 2.2, page 10.

Table 2.1 Header Weight

IMPORTANT: These are approximate weights for a single header paired with a float module . These weights include the weight of the shipping stands, and assume the header has no optional kits installed. When additional optional kits are installed, the weight will increase.	
Header Model	Weight
D225	3291 kg (7253 lb.)
D230	3655 kg (8056 lb.)
D235	3877 kg (8544 lb.)

UNLOADING HEADER

Table 2.2 Header Dimensions – Fully Assembled and Attached to Shipping Stands

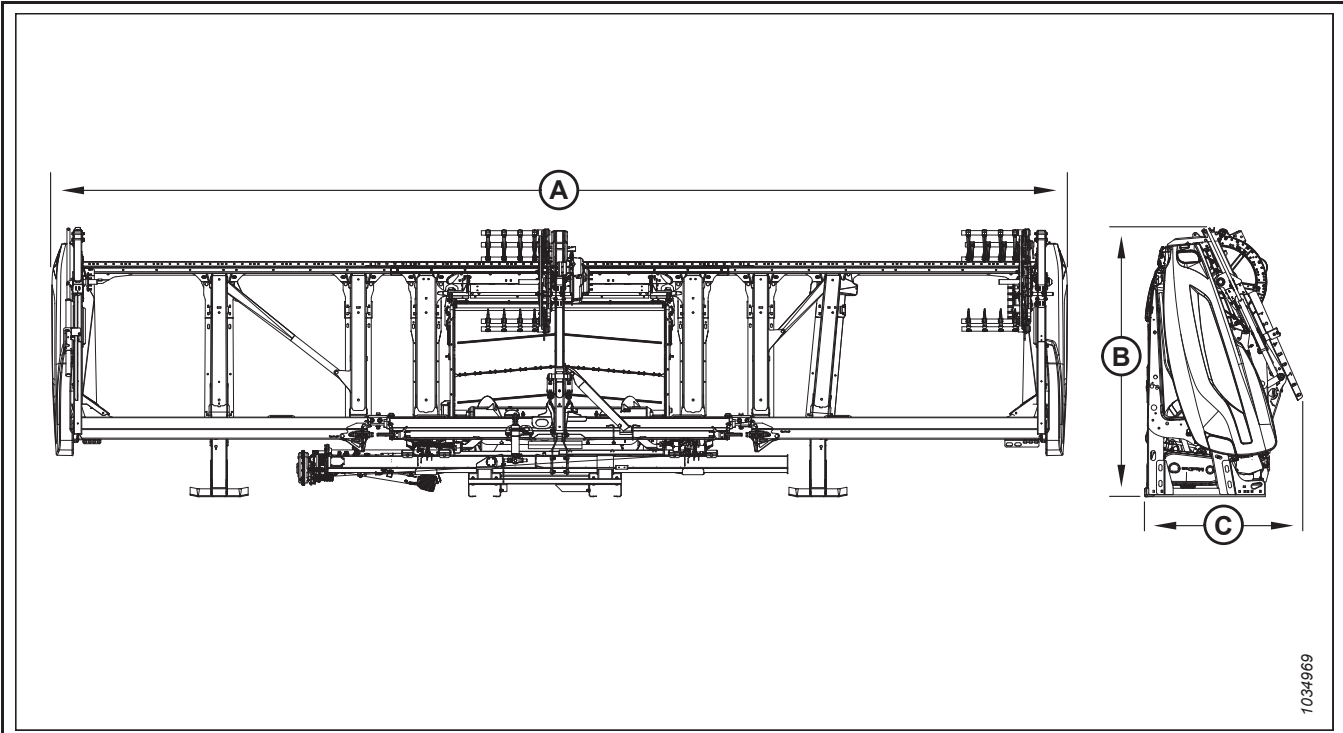

IMPORTANT:

These approximate dimensions are provided to help you choose the correct size of vehicle to lift or transport the header. These dimensions assume the header is assembled and attached to the shipping stands.

Header Model	Dimensions		
	A	B	C
D225	8.2 m (26 ft. 11 in.)	2.6 m (8 ft. 5 in.)	1.5 m (4 ft. 11 in.)
D230	9.6 m (31 ft. 7 in.)		
D235	11.2 m (36 ft. 7 in.)		

2.2 Unloading Header and Float Module from Trailer – Headers Shipped Flat

Headers can be shipped on a flat-deck trailer either lying flat or in the upright position. Headers lying flat will need to be removed from the trailer with a forklift.

DANGER

To prevent injury to bystanders caused by being struck by machinery, do NOT allow people to stand in the unloading area.

DANGER

The equipment used for loading or unloading a machine must meet or exceed the requirements specified in this document. Using inadequate equipment may result in chain breakage, vehicle tipping, machine damage or bodily harm to operators or bystanders.

IMPORTANT:

To unload headers shipped flat, the forklift must have a fork length of minimum 2286 mm (90 in.) to ensure that the forks extend beyond the cutterbar.

IMPORTANT:

For the minimum lifting equipment requirements, refer to [2.1 Header Specifications for Unloading and Assembly, page 9](#).

To unload the header from the trailer, follow these steps:

1. Move the trailer into position, block the trailer wheels, and lower the trailer storage stands.
2. Approach the header from the back. Slide the forks underneath the float module's lower beam structure as far forward as possible.

IMPORTANT:

Ensure that the forks extend beyond the cutterbar. If the forks do not lift at the cutterbar, damage to the header may occur.

3. Remove the tie-down straps, chains, and wooden blocks.
4. Slowly raise the header off the trailer deck until the header clears the trailer deck by 102–204 mm (4–8 in.).

IMPORTANT:

Maintain adequate clearance between the header and the trailer.

DANGER

Ensure that the forks on the forklift are secure and that no bystanders are present.

5. Back the forklift away from the trailer until the header clears the trailer. Slowly lower the header until it is 150 mm (6 in.) off of the ground.
6. Take the header to the storage or setup area. Ensure that the area is flat and free of rocks or debris that could damage the header.

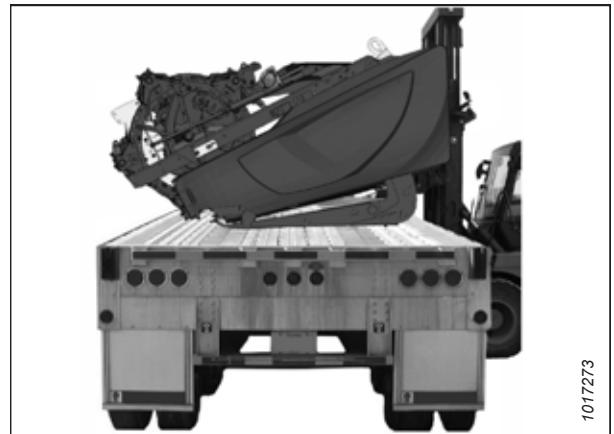

Figure 2.1: Header on Flat Deck

1017273

UNLOADING HEADER

7. Place 254 mm (10 in.) blocks (A) under each end of the header, and one on each side of the float module. Lower the header onto the blocks.

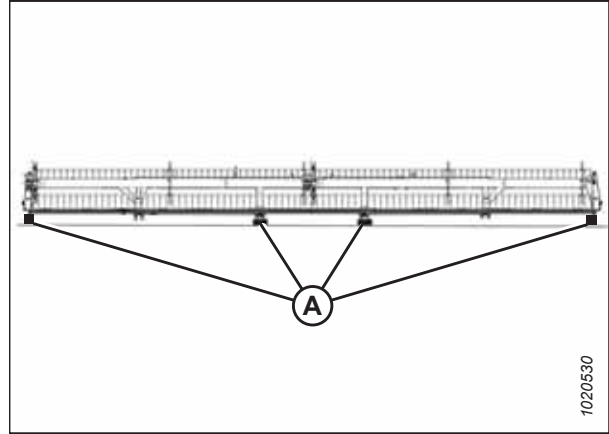

Figure 2.2: Blocks at Each End of Cutterbar

2.3 Unloading Header and Float Module from Trailer – Headers Shipped Upright

Headers can be shipped on a flat-deck trailer either lying flat or in the upright position. Pairs of headers are shipped in the upright position. Headers in the upright position will need to be removed from the trailer with a forklift.

DANGER

To prevent injury to bystanders caused by being struck by machinery, do NOT allow people to stand in the unloading area.

DANGER

The equipment used for loading or unloading a machine must meet or exceed the requirements specified in this document. Using inadequate equipment may result in chain breakage, vehicle tipping, machine damage or bodily harm to operators or bystanders.

IMPORTANT:

For the minimum lifting equipment requirements, refer to *2.1 Header Specifications for Unloading and Assembly, page 9*.

To unload the headers from a trailer, follow these steps:

1. Move the trailer into position and block the trailer wheels.
2. Lower the trailer storage stands.
3. Approach one of the headers and line up forks (A) with fork slider channels (B) under the float module frame.
4. Slide forks (A) underneath fork slider channels (B) as far as possible without contacting the shipping support of the opposite header.
5. Remove the tie-down straps, chains, and wooden blocks.
6. Slowly raise the header off of the trailer deck.

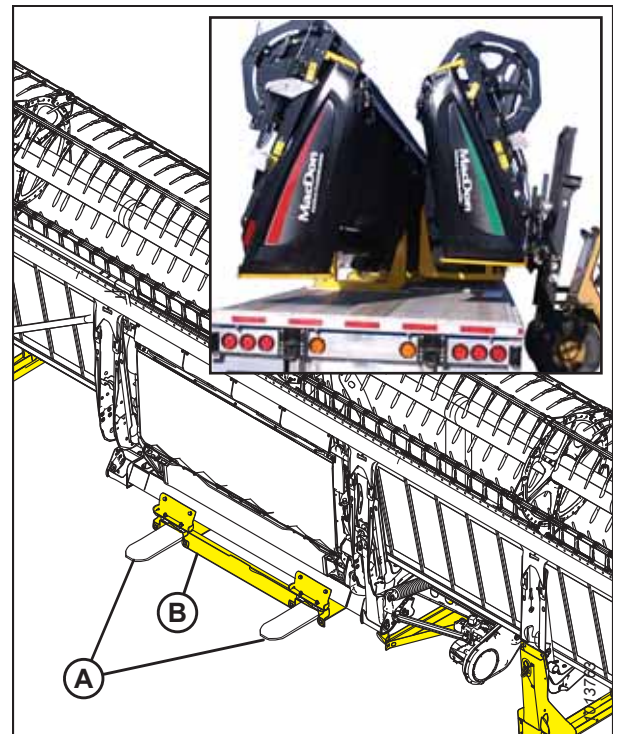

Figure 2.3: Header Shipping Supports

UNLOADING HEADER

DANGER

Ensure that the forks on the forklift are secure and that no bystanders are present.

7. Back the forklift away from the trailer until the header clears the trailer. Slowly lower the header until it is 254 mm (10 in.) above the ground.
8. Take the header to the storage area. Set the header down securely on level ground free of rocks and debris.
9. Repeat this procedure to unload the second header.

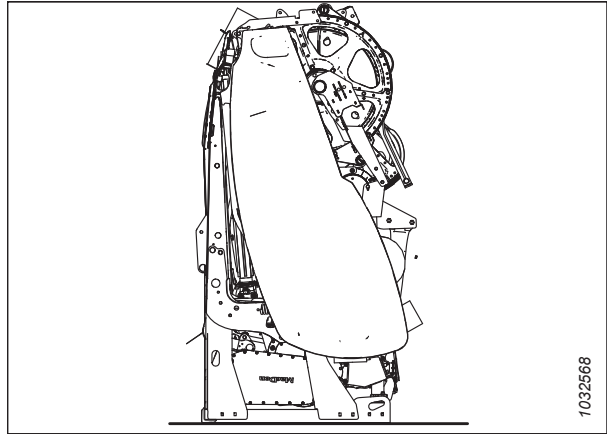

Figure 2.4: Header on Level Ground

2.4 Removing Upper Cross Auger from Shipping Location – Option

If the header was ordered with an upper cross auger (UCA), the UCA will be secured to the front of the header for shipping. The UCA components will need to be removed from the header before the header can be lowered into field position.

If the header was shipped without a UCA, proceed to [2.5 Removing Parts from Shipping Location, page 16](#).

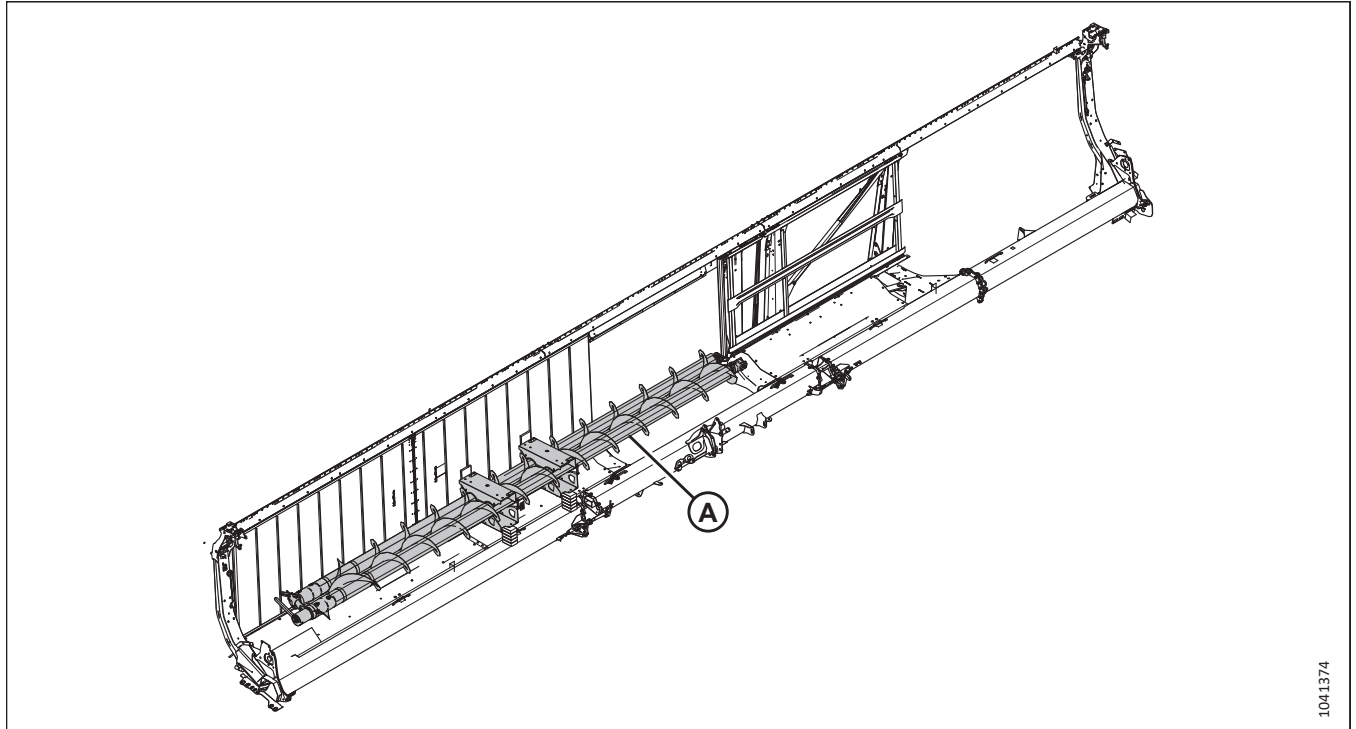

Figure 2.5: Double-Reel Header with Two-Piece Upper Cross Auger (UCA)

1. Remove any banding and blocks securing UCA (A) to the header.

IMPORTANT:

When positioning a forklift or lifting device use the pockets on the UCA shipping bracket to avoid damaging the attached aluminum deflectors.

2. Set the UCA aside.

2.5 Removing Parts from Shipping Location

The header was shipped with several parts strapped to the draper deck and reel. They will need to be removed from the header.

NOTE:

Parts can also be removed after the header is lowered to field position.

1. Remove and set aside left clearance light (A).



Figure 2.6: Parts Secured to Header

2. Remove and set aside reel endshield bags (A).
3. Remove and set aside right clearance light (B).

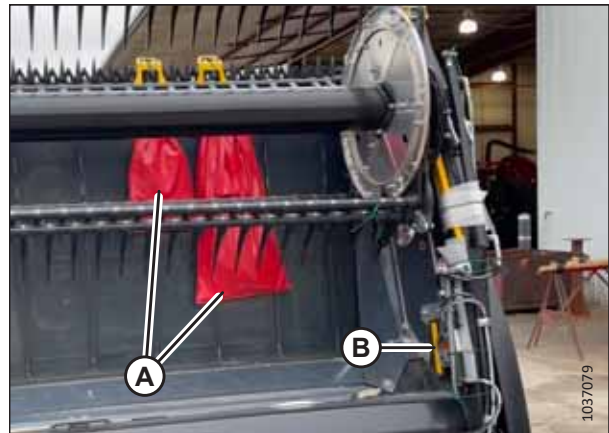

Figure 2.7: Parts Bags Secured to Draper Deck

2.6 Lowering Header to Field Position – D225

Headers shipped upright will need to be lowered to the ground so that the final assembly procedures can be performed.



DANGER

The equipment used for loading or unloading a machine must meet or exceed the requirements specified in this document. Using inadequate equipment may result in chain breakage, vehicle tipping, machine damage or bodily harm to operators or bystanders.



DANGER

Ensure that all bystanders have cleared the area.

For the minimum lifting equipment requirements, refer to [2.1 Header Specifications for Unloading and Assembly, page 9](#).

UNLOADING HEADER

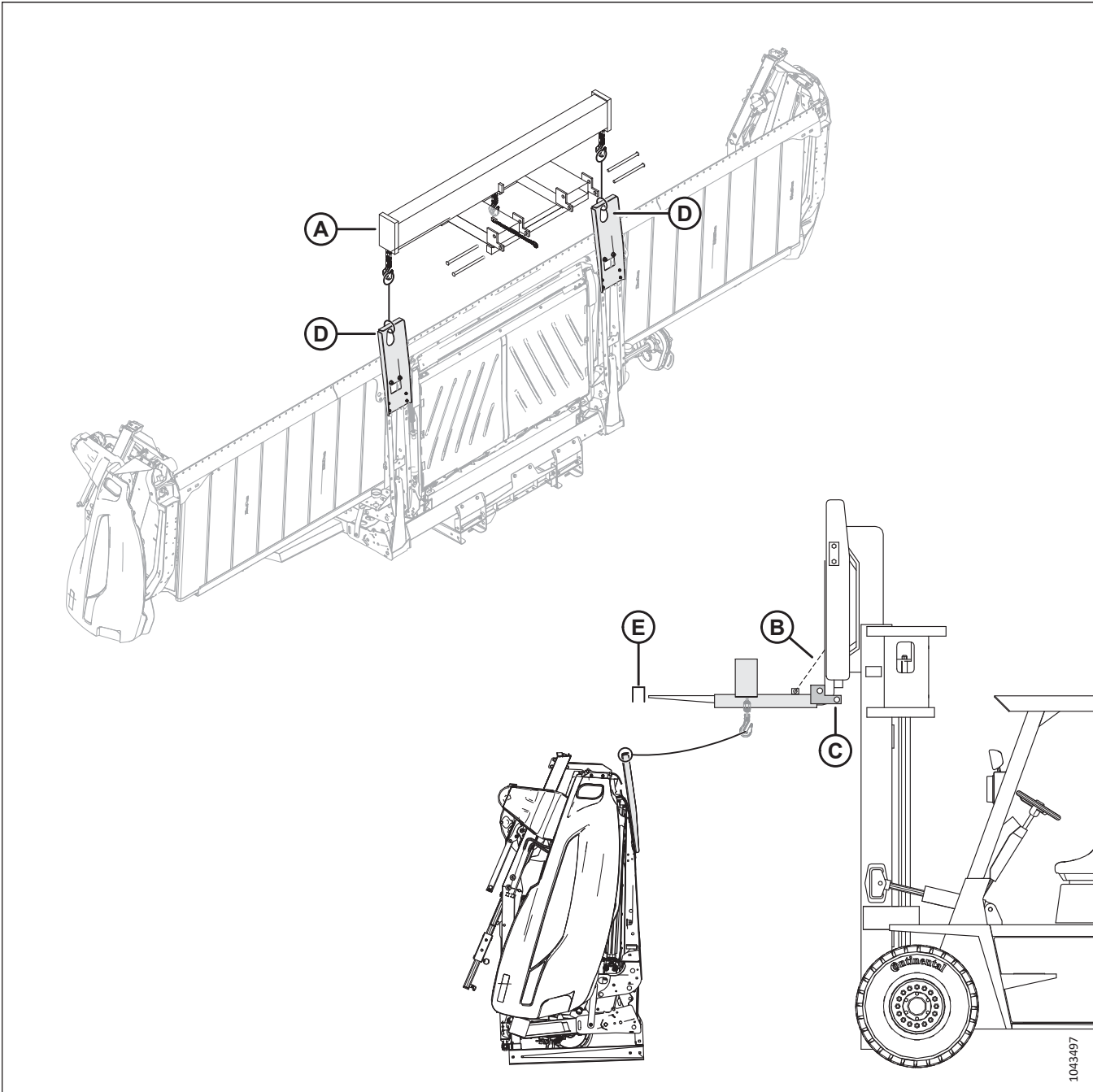

Figure 2.8: Upright Header, Spreader Bar, and Forklift

1. Attach a spreader bar (A) to a forklift. Make sure any devices designed to prevent the spreader bar from falling off the forklift, such as safety chains (B) and locking pins (C), are installed according to the spreader bar manufacturer's instructions.
2. Approach the underside of the header with the forklift. Hang a chain at both ends of the spreader bar. Attach the other end of the chains to tipping plates (D). Make sure there is clearance (E) between the forks and the tipping plates.

UNLOADING HEADER

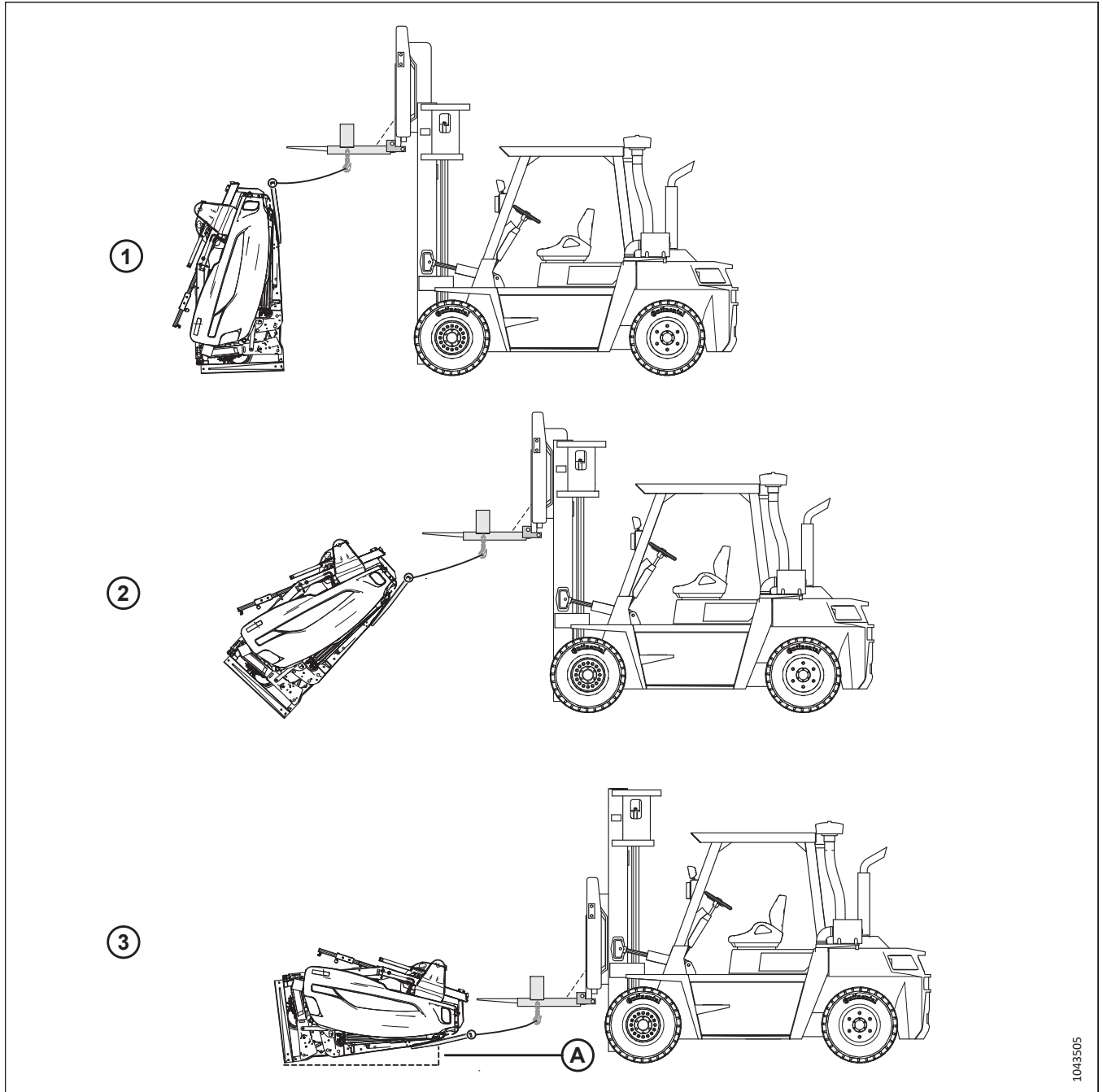

Figure 2.9: Tipping Header into Field Position

3. Back the forklift up **SLOWLY** while lowering the forks, until the header's cutterbar is approximately 254–306 mm (10–14 in.) (A) off the ground.

IMPORTANT:

Ensure that the tension on the chains remains as consistent as possible while the header is lowered.

UNLOADING HEADER

- Place four 254 mm (10 in.) blocks (A) under the header: one at each end of the header and one on each side of the float module.
- Lower the header onto the blocks.
- Remove the chains from the header.

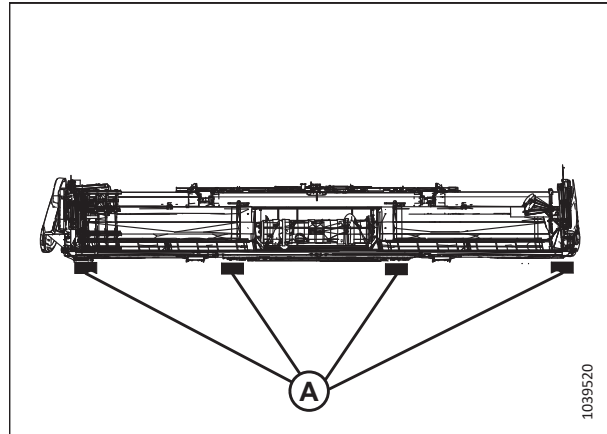

Figure 2.10: Blocks Positioned under Header

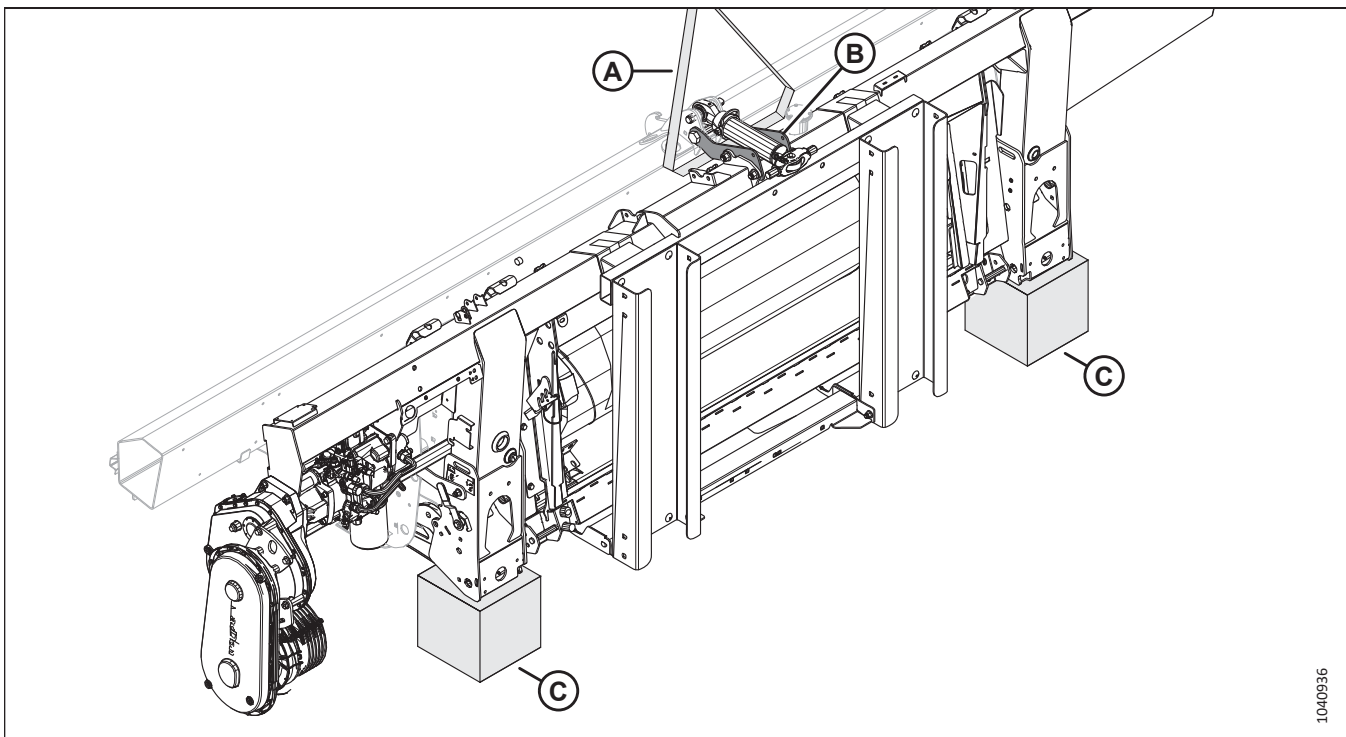

Figure 2.11: Blocks Positioned under Float Module

- Loop strap (A) under shipping brackets (B).
- Attach the other end of the strap to the fork of a forklift.
- Use the forklift to raise the back of the header until it is 254–306 mm (10–14 in.) off of the ground.
- Place 254 mm (10 in.) blocks (C) under the float module.
- Lower the header onto blocks (C).
- Remove the chain from the header.
- Back the forklift away from the header.

2.7 Lowering Header to Field Position – D230 and D235

Double-reel headers shipped upright will need to be lowered to the ground so that the final assembly procedures can be performed.

DANGER

The equipment used for loading or unloading a machine must meet or exceed the requirements specified in this document. Using inadequate equipment may result in chain breakage, vehicle tipping, machine damage or bodily harm to operators or bystanders.

DANGER

Ensure that all bystanders have cleared the area.

For the minimum lifting equipment requirements, refer to [2.1 Header Specifications for Unloading and Assembly, page 9](#).

1. Approach the underside of the header with the lifting vehicle.

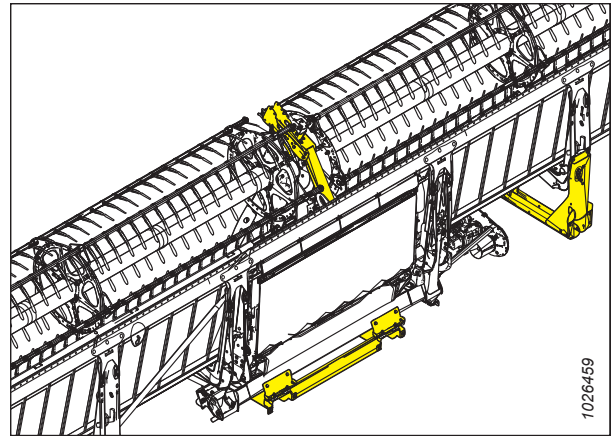

Figure 2.12: Underside of Header

2. Attach a chain to shipping support (A) on the center reel arm.

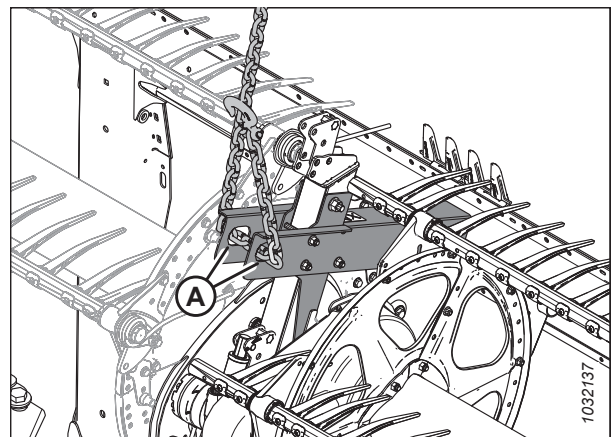

Figure 2.13: Chain Attachment Location – Double Reel

UNLOADING HEADER

- Place 254 mm (10 in.) blocks (A) under each end of the header, and one on each side of the float module.

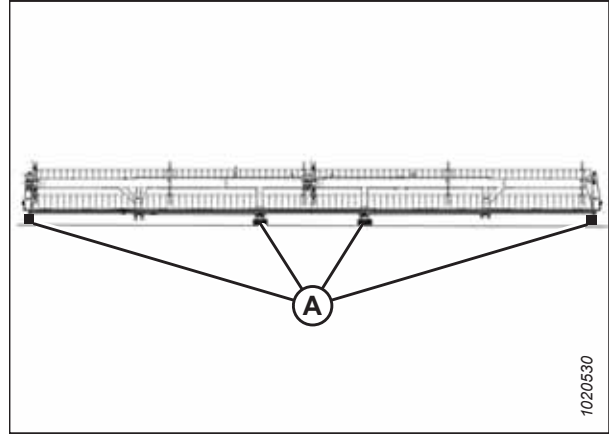

Figure 2.14: Blocks at Each End of Cutterbar

UNLOADING HEADER

4. Back up **SLOWLY** while lowering the forks until the header rests on the blocks.
5. Remove the chain from both shipping supports.



Figure 2.15: Header Lowered to Field Position

UNLOADING HEADER

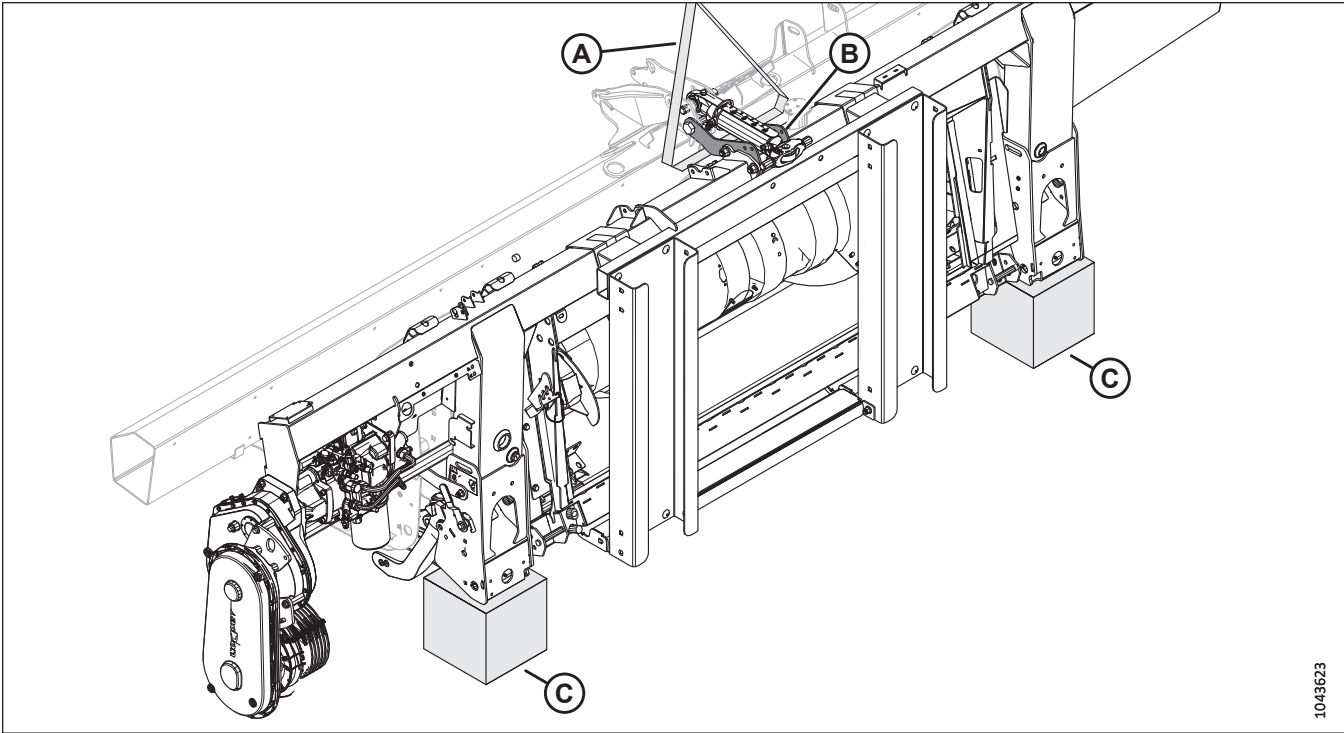

1043623

Figure 2.16: Blocks Positioned under Float Module

6. Loop strap (A) under shipping brackets (B).
7. Attach the other end of the strap to the fork of a forklift.
8. Use the forklift to raise the back of the header until it is 254–306 mm (10–14 in.) off of the ground.
9. Place 254 mm (10 in.) blocks (C) under the float module.
10. Lower the header onto blocks (C).
11. Remove the chain from the header.
12. Back the forklift away from the header.

2.8 Removing Crop Dividers From Single Reel Shipping Position, and Installing Deflector Hardware – D225 (Parts Bag MD #357731)

The crop dividers need to be moved from their shipping location for later installation.

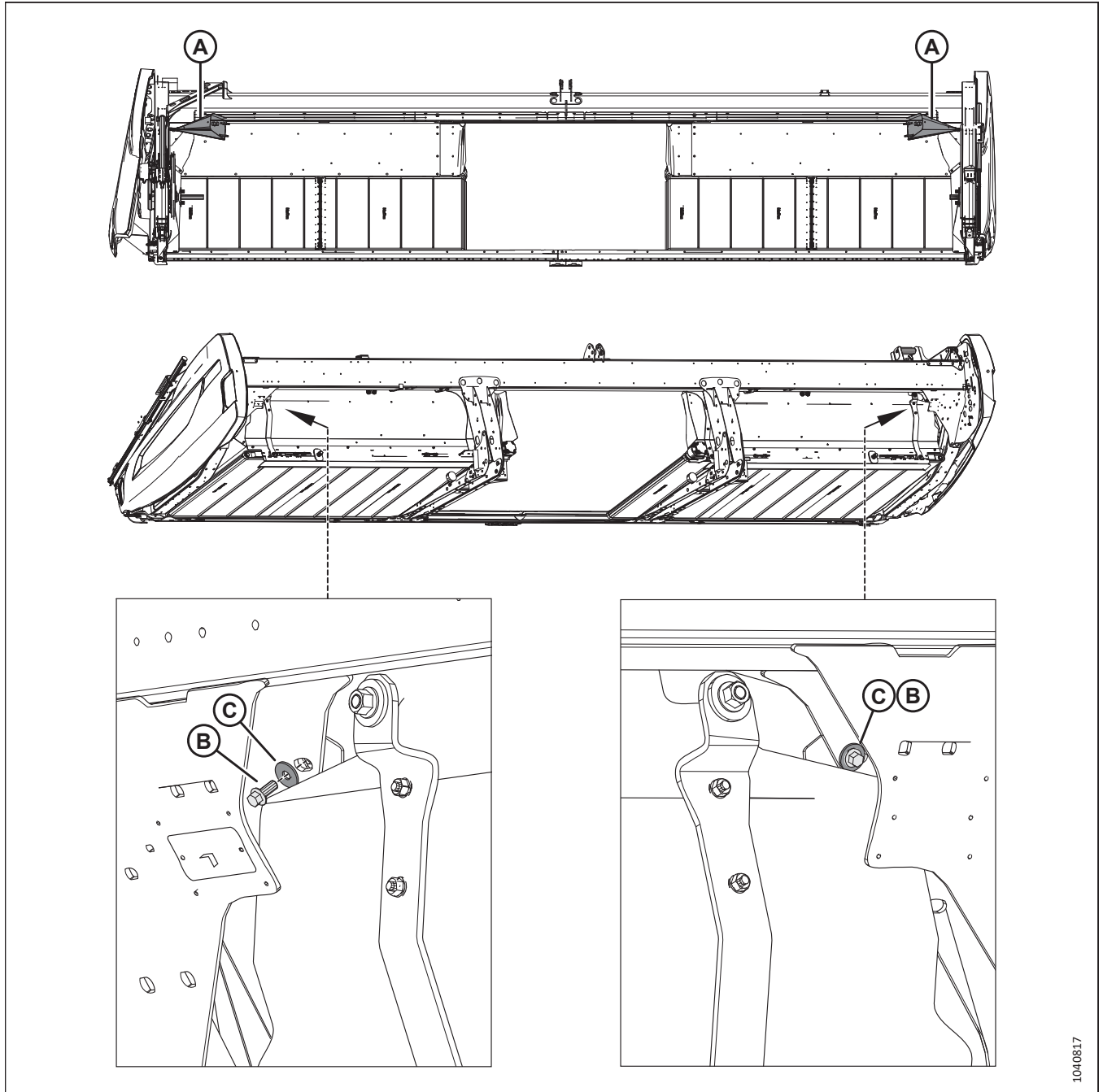
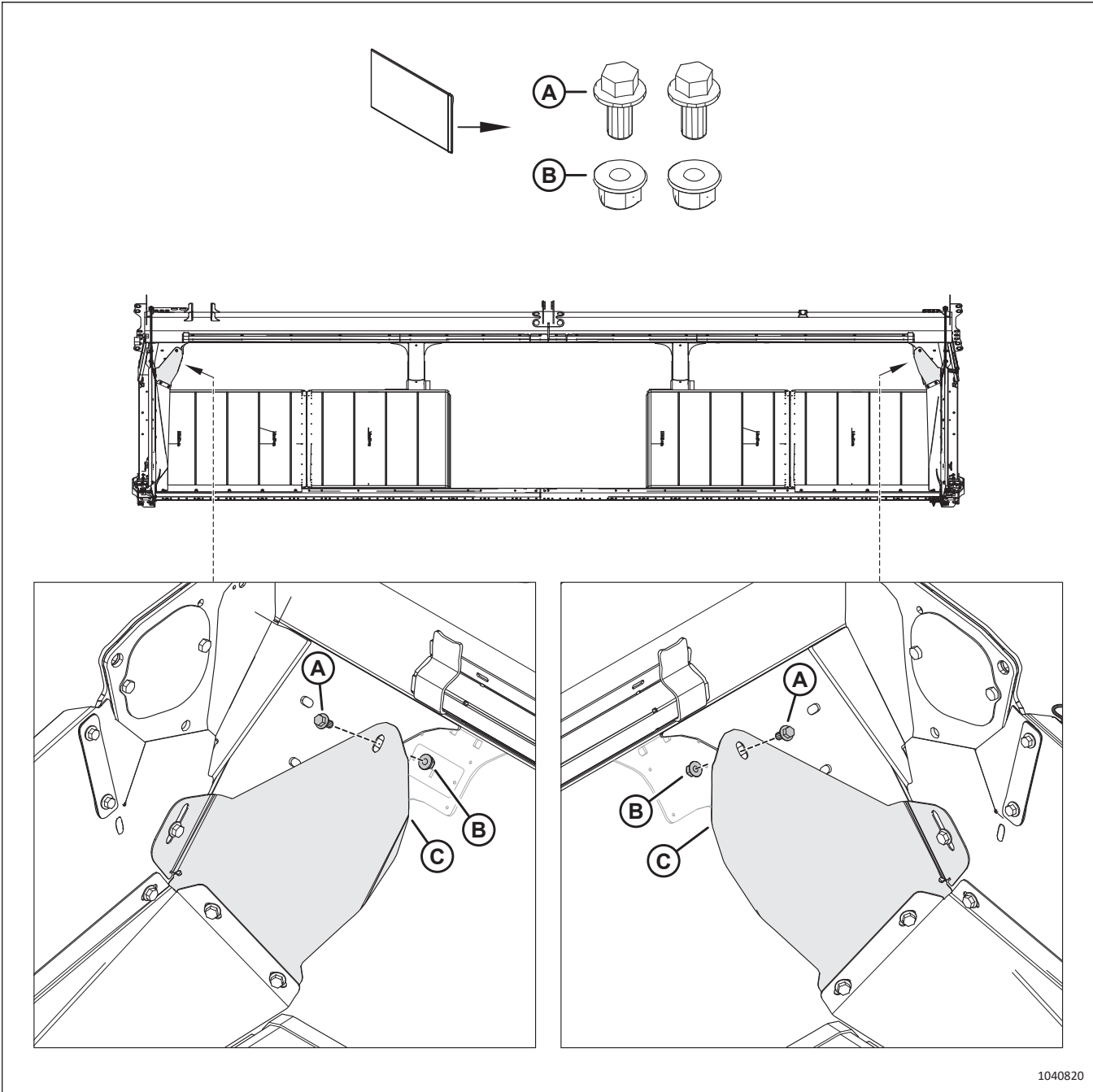

Figure 2.17: Crop Dividers Shipping Location

1. Remove shipping wire from crop dividers (A).
2. Remove and discard bolts (B) and washers (C) that attach the crop dividers to the deflectors.
3. Set the crop dividers aside.

UNLOADING HEADER



1040820

Figure 2.18: Deflector Hardware Installation

4. Retrieve parts bag MD #357731, which contains the following:
 - Two M10 bolts (A)
 - Two M10 nuts (B)
5. Attach deflectors (C) to header using M10 bolt (A) and nut (B).

2.9 Removing Crop Dividers From Double Reel Shipping Position – D230 and D235

The crop dividers need to be moved from the shipping location for later installation.

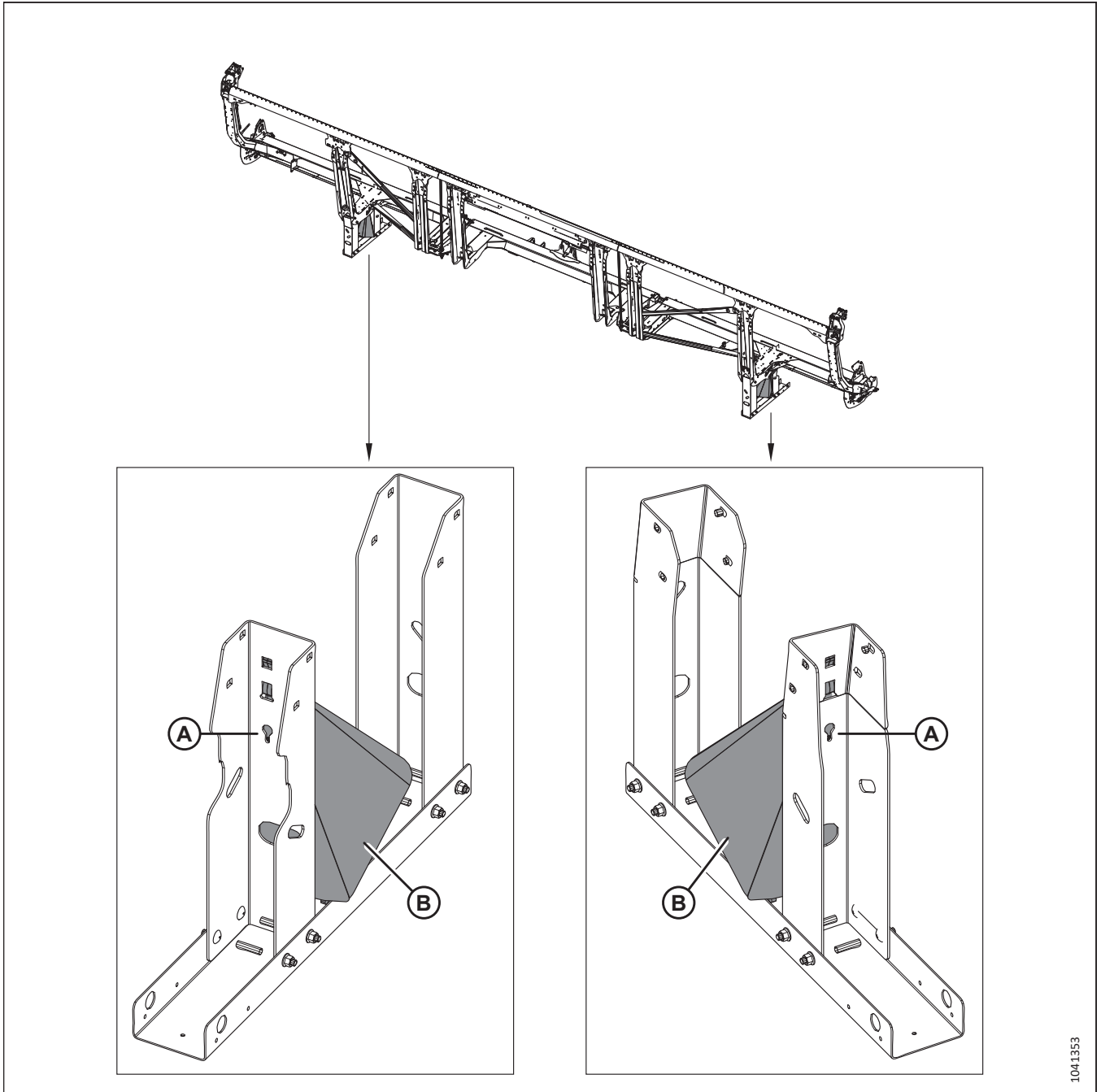

Figure 2.19: Crop Dividers Shipping Location

1. Remove and discard bolts (A).
2. Set both crop dividers (B) aside.

2.10 Removing Shipping Stands and Supports – D225

Parts used to secure the header for shipping must be removed from the header.

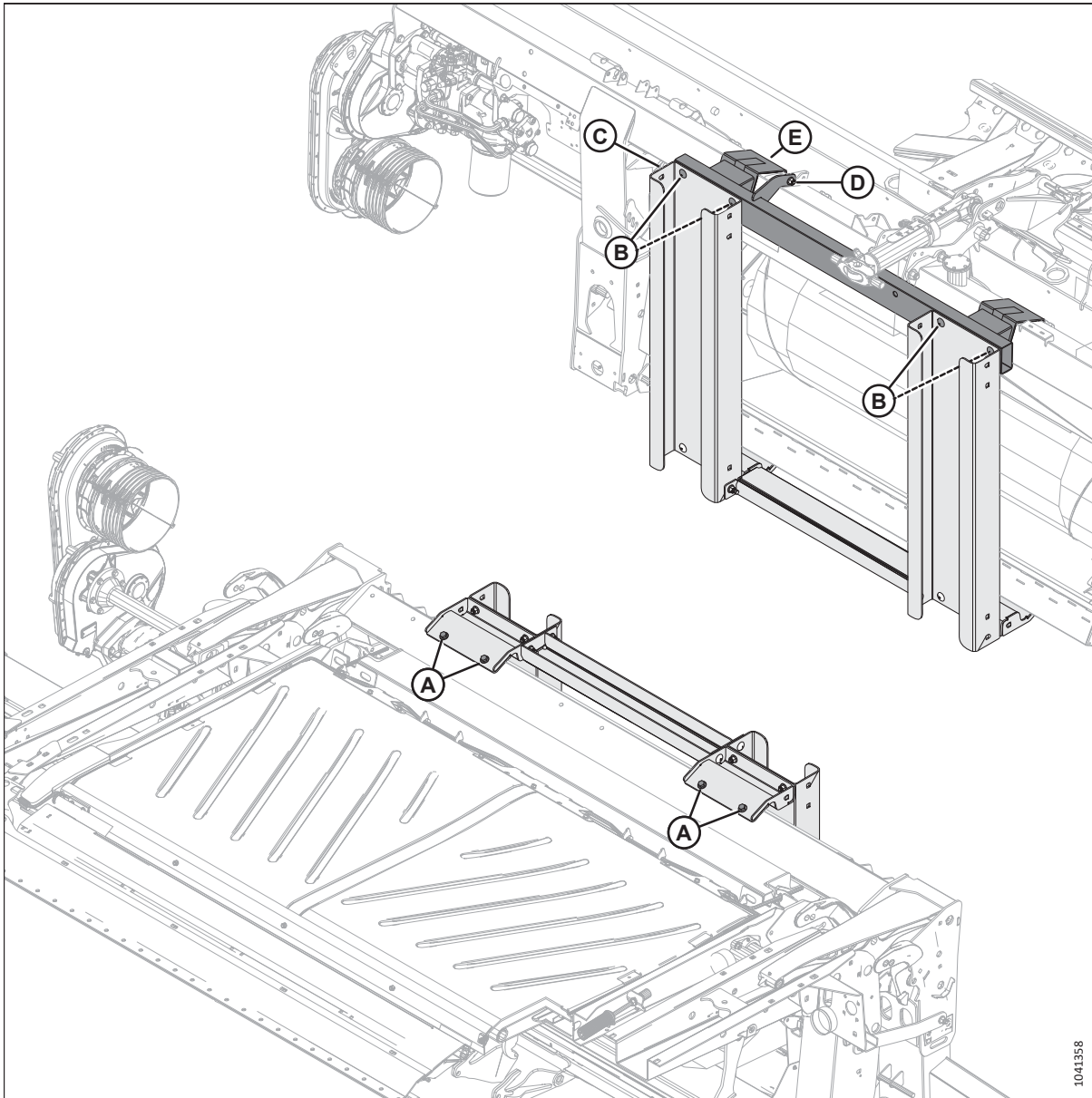

Figure 2.20: Shipping Stands

1. Ensure that the float module is resting on 254 mm. (10 in.) blocks so that you can access the bolts at the float module support stand.

NOTE:

The blocks should have been positioned when the header was tipped over. For instructions on positioning the blocks, refer to [2.6 Lowering Header to Field Position – D225, page 17](#).

2. Remove and discard the following:
 - a. Hardware (A), (B), and stand (C).
 - b. Hardware (D) and stand (E).

UNLOADING HEADER

3. Remove and discard hardware (A) and shipping tag (B) from the inboard deck support.
4. Repeat the previous step to remove the shipping tag from the opposite deck.

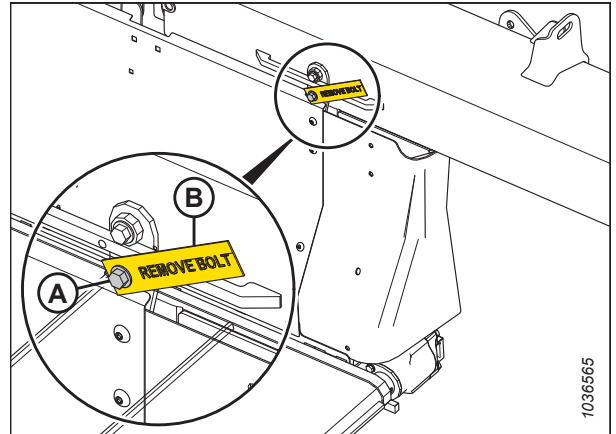

Figure 2.21: Deck Support Shipping Bolt

5. On the front of the header, remove six nuts (A) from right shipping foot (B). Remove right shipping foot (B).
6. Repeat the previous step to remove the left shipping foot.

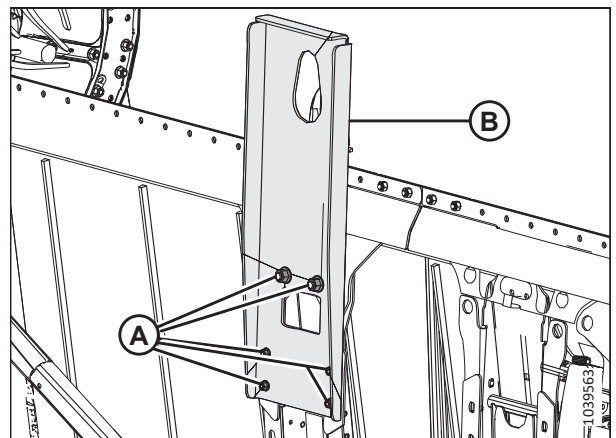
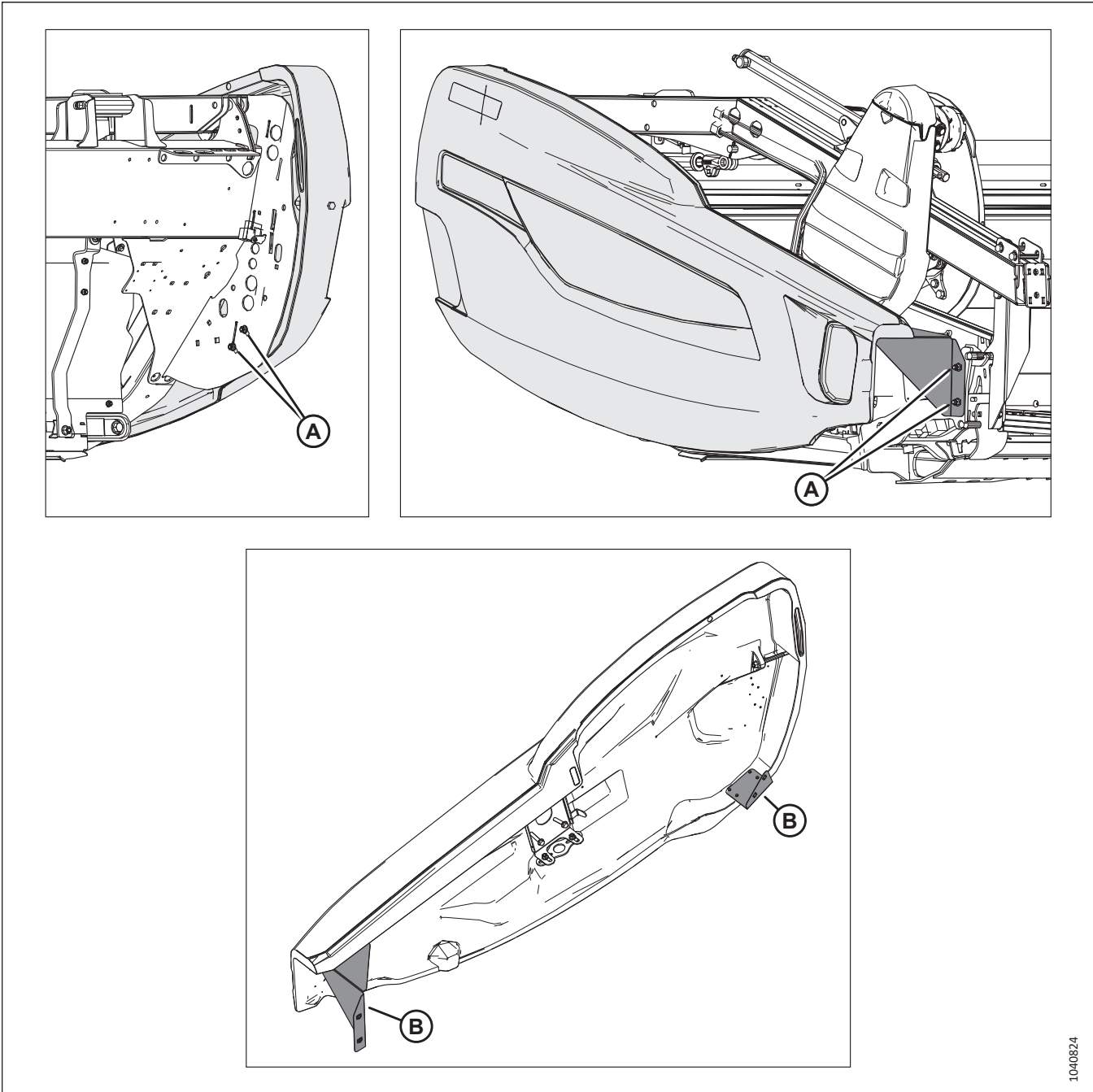

Figure 2.22: Right Shipping Foot – View from Below

UNLOADING HEADER



1040824

Figure 2.23: Right Endshield in Shipping Configuration

7. On the right endshield, remove and discard hardware (A).
8. Remove brackets (B). Discard the hardware and brackets.

2.11 Removing Shipping Stands – D230 and D235

Shipping stands prevent damage to the header during shipping. They will need to be removed from the header.

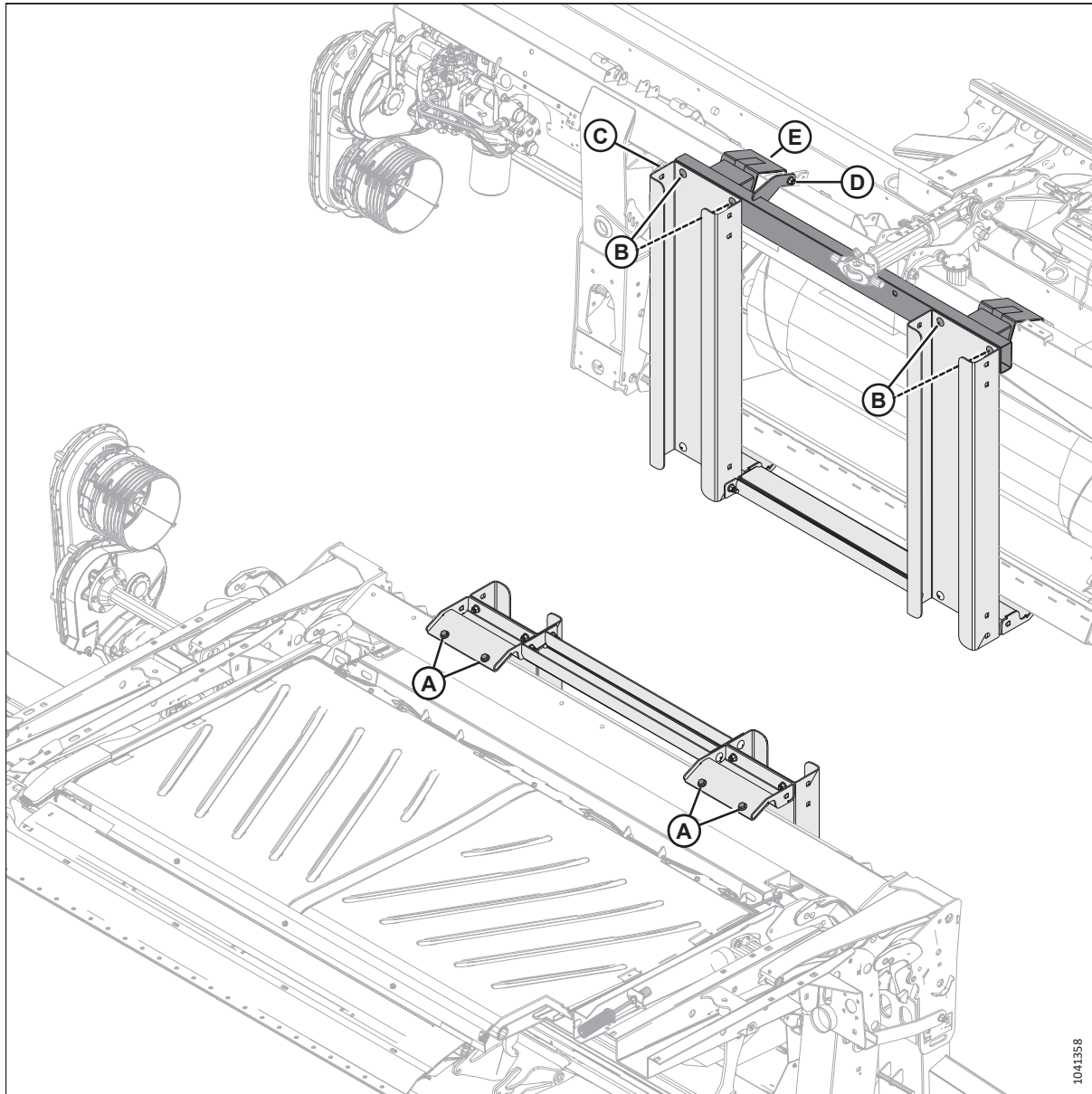

Figure 2.24: Shipping Stands

1. Ensure that the float module is resting on 254 mm. (10 in.) blocks so that you can access the bolts at the float module support stand.

NOTE:

The blocks should have been positioned when the header was tipped over. For instructions on positioning the blocks, refer to [2.11 Removing Shipping Stands – D230 and D235, page 31](#).

2. Remove and discard the following:
 - a. Hardware (A), (B), and stand (C).
 - b. Hardware (D) and stand (E).

UNLOADING HEADER

3. Remove eight bolts (A) and shipping stand (B) from both outboard header legs.

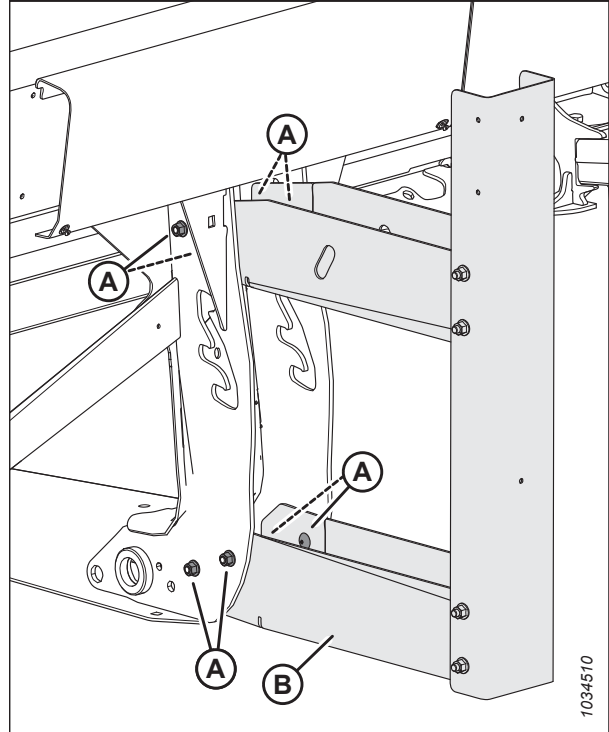

Figure 2.25: Right Shipping Stand on Outboard Leg

4. Remove and discard hardware (A) and shipping tag (B) from both inboard deck supports.

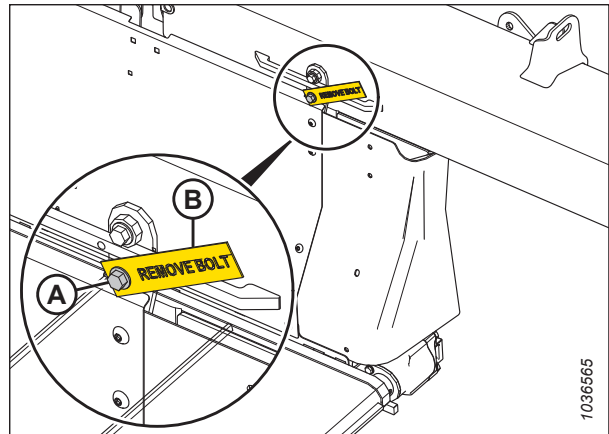

Figure 2.26: Right Deck Support Shipping Bolt

2.12 Removing Anti-Rotation Strap from Reel and Installing Knife Cover Hardware – D225, D230, and D235 (Parts Bag MD #347598)

The anti-rotation strap prevents the reel from rotating during shipping.

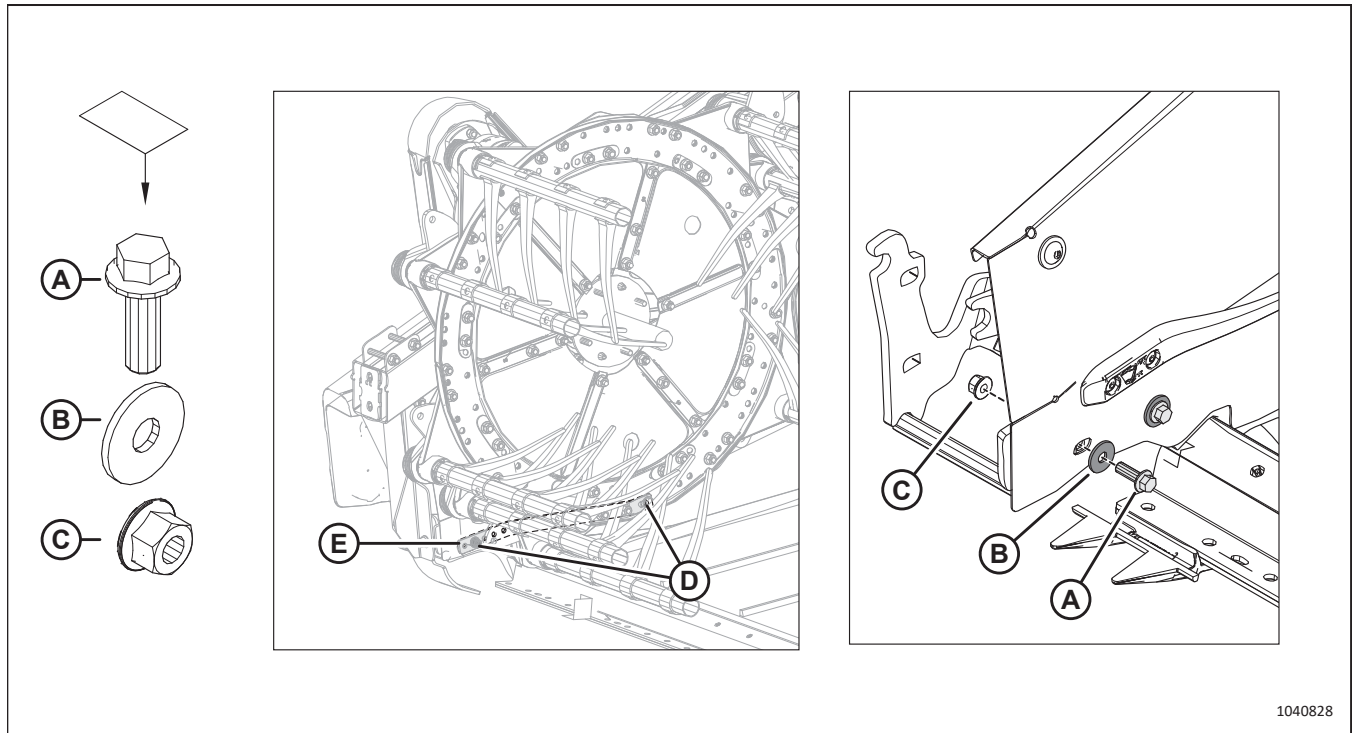

Figure 2.27: Anti-Rotation Strap Removal, Installation of Knife Cover Hardware

1. Ensure that the header is resting on 254 mm (10 in.) blocks.

CAUTION

If the reel is not supported, it can rotate, which can result in injury.

2. Use an appropriate lifting device to support the weight of the reel and to prevent it from rotating.
3. Retrieve parts bag MD #347598, which contains the following:
 - One M10 x 30 bolt (A)
 - One M10 washer (B)
 - One M10 nut (C)
4. Remove hardware (D) securing anti-rotation strap (E). Discard the hardware and strap.
5. Install M10 bolt (A), washer (B), and nut (C) to secure the endsheet to the header frame.
6. Tighten nut (C) to 11 Nm (97 lbf-in [8 lbf-ft]).

Chapter 3: Setting up Float Module

The float module allows the header to interface with the combine. Some parts of the float module were removed or their position changed for shipping purposes. They will need to be installed or repositioned now.

Perform the procedures in this chapter in the order in which they are listed. Not all procedures apply to all header models.

3.1 Repositioning Completion Gearbox to Working Position

The float module's completion gearbox was placed in the forward position for shipping purposes. It will need to be moved to the working position.

1. Loosen hex bolt (A) on main gearbox bracket (B).

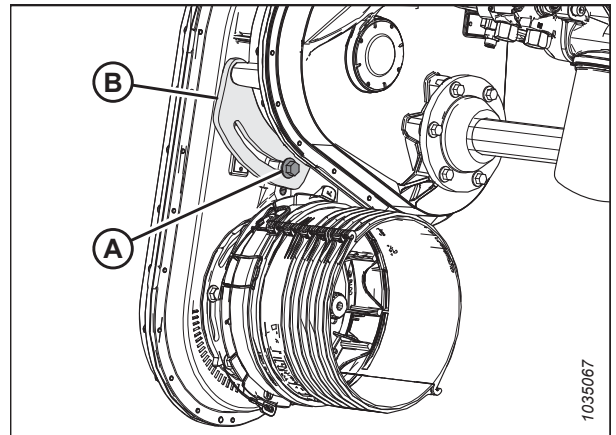

Figure 3.1: Shipping Position

2. Remove and retain two hex bolts (A) from main gearbox bracket (B).
3. Swing completion gearbox rearward. Align the mounting holes on the bracket with the mounting holes on main gearbox bracket (B).

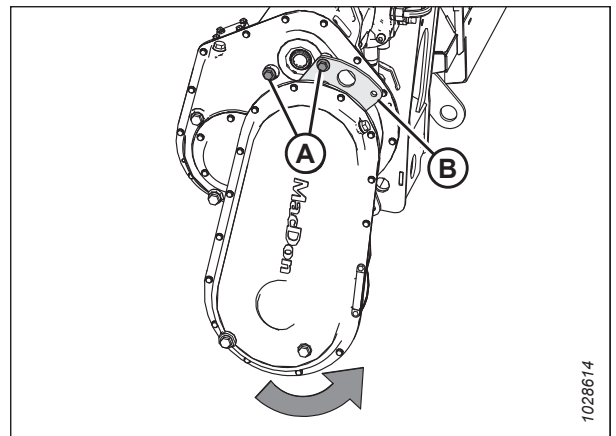

Figure 3.2: Shipping Position

SETTING UP FLOAT MODULE

4. Secure bracket (A) with two retained M12 hex bolts (B).
5. Tighten the two M12 hex bolts to 58 Nm (42 lbf-ft).

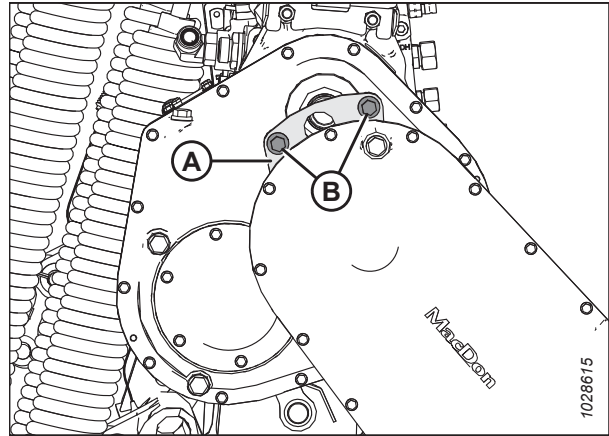

Figure 3.3: Working Position

3.2 Installing Standard Driveline (B7038, B7039, or B7108)

The driveline connects the float module's completion gearbox to the combine's power take-off (PTO). It will need to be installed on the float module.

CAUTION

To prevent injury to the installer and damage to the driveline, hold the driveline so that it doesn't fall to the floor or ground.

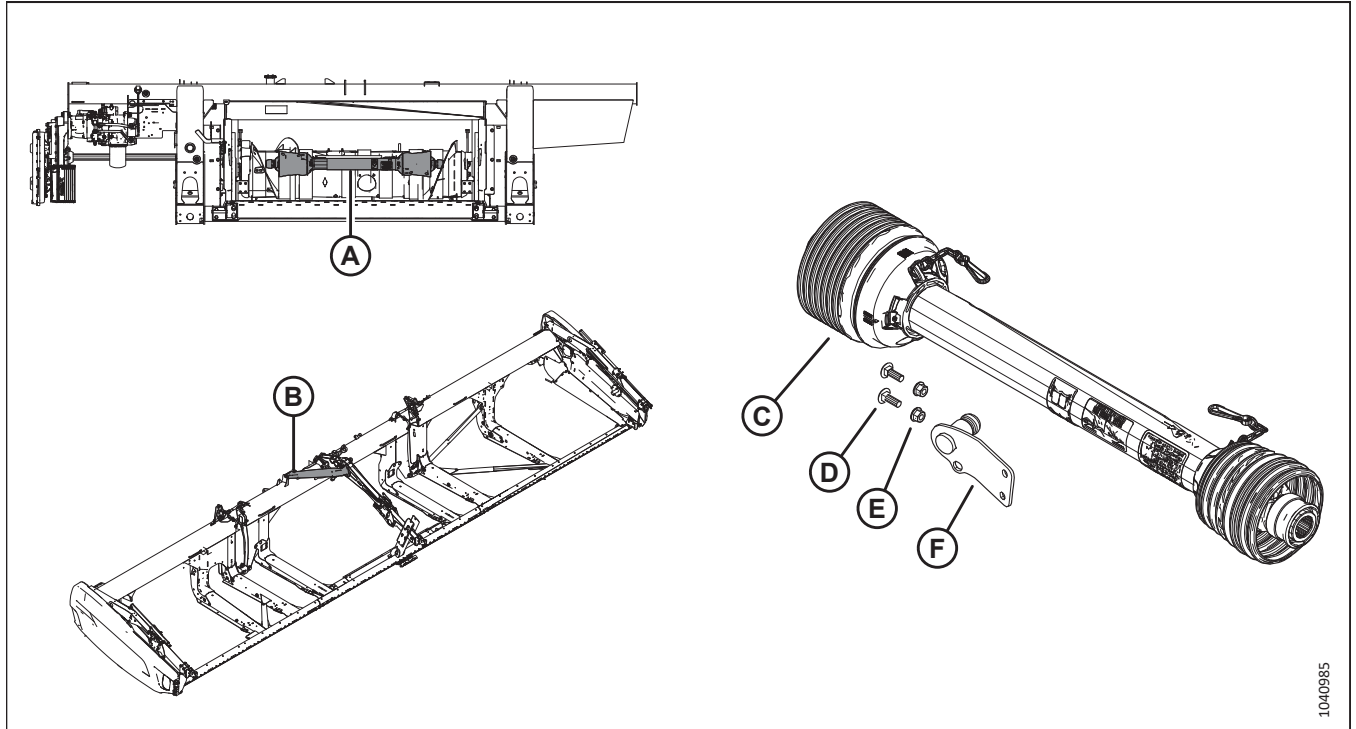

Figure 3.4: Driveline Shipping Locations and Driveline Parts

1. Retrieve the following driveline parts that are shipped packaged on feed auger (A) or reel arm brace (B):

- Driveline (C)
- Two M10 x 1.5 x 30 bolts (D)
- Two M10 nuts (E)
- Driveline storage support (F)

NOTE:

The appearance of storage support (F) varies according to the bundle.

SETTING UP FLOAT MODULE

2. Position driveline storage support (A) on the left side of the float module as shown. Secure the support with two M10 x 1.5 x 30 carriage bolts and hex flange nuts (B).

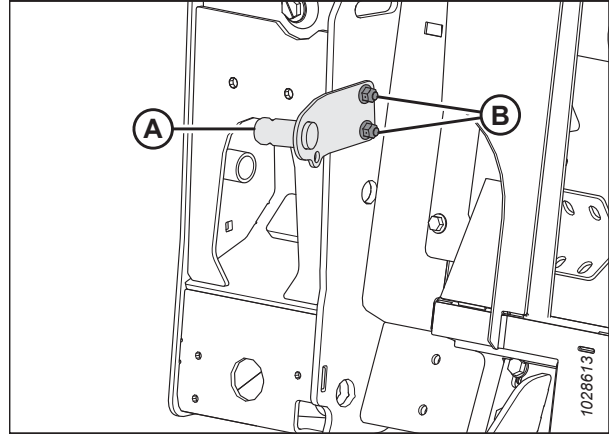

Figure 3.5: Driveline Support

3. On the completion gearbox, pry clips (A) off of shield (B). Remove the shield.

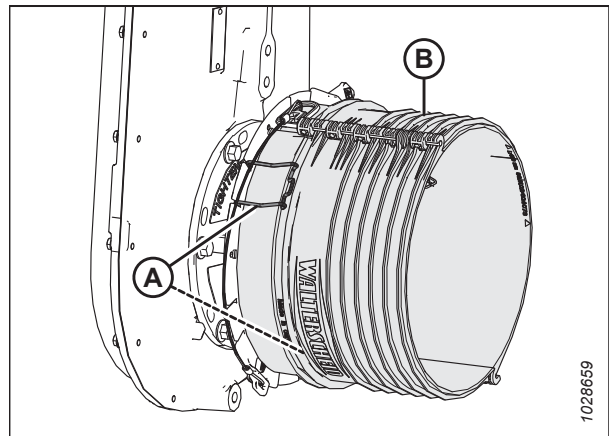

Figure 3.6: Driveline Shield on Float Module Gearbox

NOTE:

Ensure that the arrow on the driveline decal points toward the combine. The appearance of the decal on the driveline varies.



Figure 3.7: Sample Driveline Decal

SETTING UP FLOAT MODULE

- Slide shield (A) onto the driveline.
- Pull back collar (B). Slide the quick disconnect yoke onto the shaft on the float module's gearbox until the yoke locks onto the shaft. Release the collar.

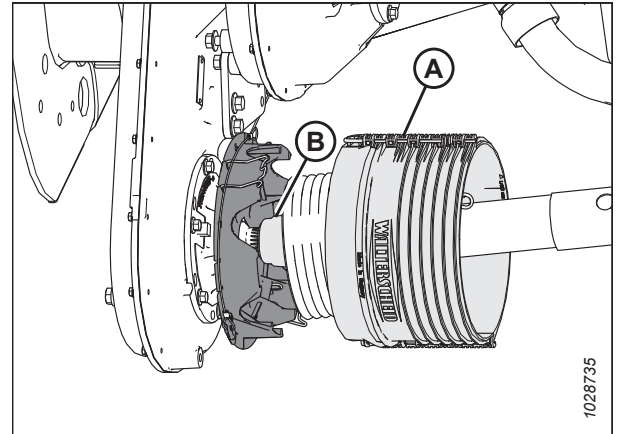

Figure 3.8: Driveline Installed on Float Module Gearbox Shaft

- Secure shield (A) with clips (B).

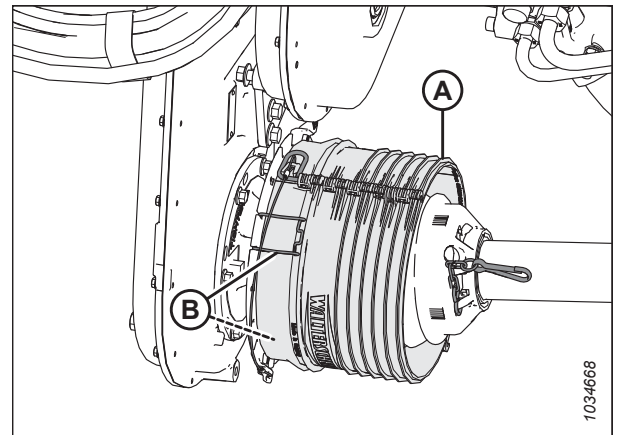

Figure 3.9: Driveline with Shield Installed on Float Module Gearbox

- Secure the loose end of safety chain (A) to the ear on the aluminum plate.

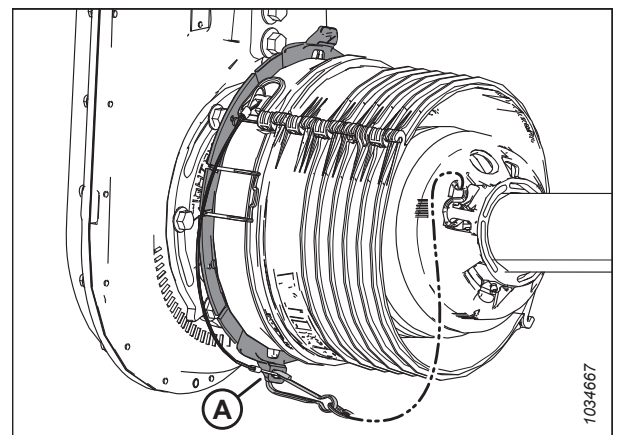

Figure 3.10: Chain Secured to Driveline on Float Module Gearbox

SETTING UP FLOAT MODULE

8. Pull back the collar on driveline (A). Slide driveline yoke (A) onto the shaft on storage support (B) until the yoke locks onto the shaft. Release the collar.
9. Secure the loose end of safety chain (C) to the driveline storage support.

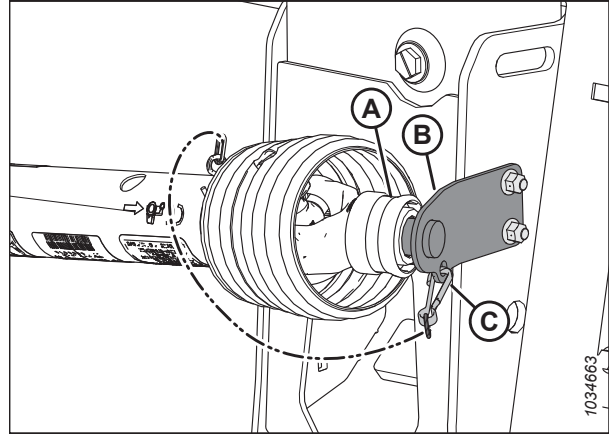

Figure 3.11: Driveline in Storage Position

3.3 Installing Driveline for Combines Equipped with a Slope Compensation Package (B7180, B7181, B7182, or B7326)

The driveline connects the float module's completion gearbox to the combine's power take-off (PTO). This type of driveline allows the header to operate more effectively on sloped terrain, and requires the combine to be equipped with a slope compensation package. It will need to be installed on the float module.

CAUTION

To prevent injury to the installer and damage to the driveline, do not drop the driveline.

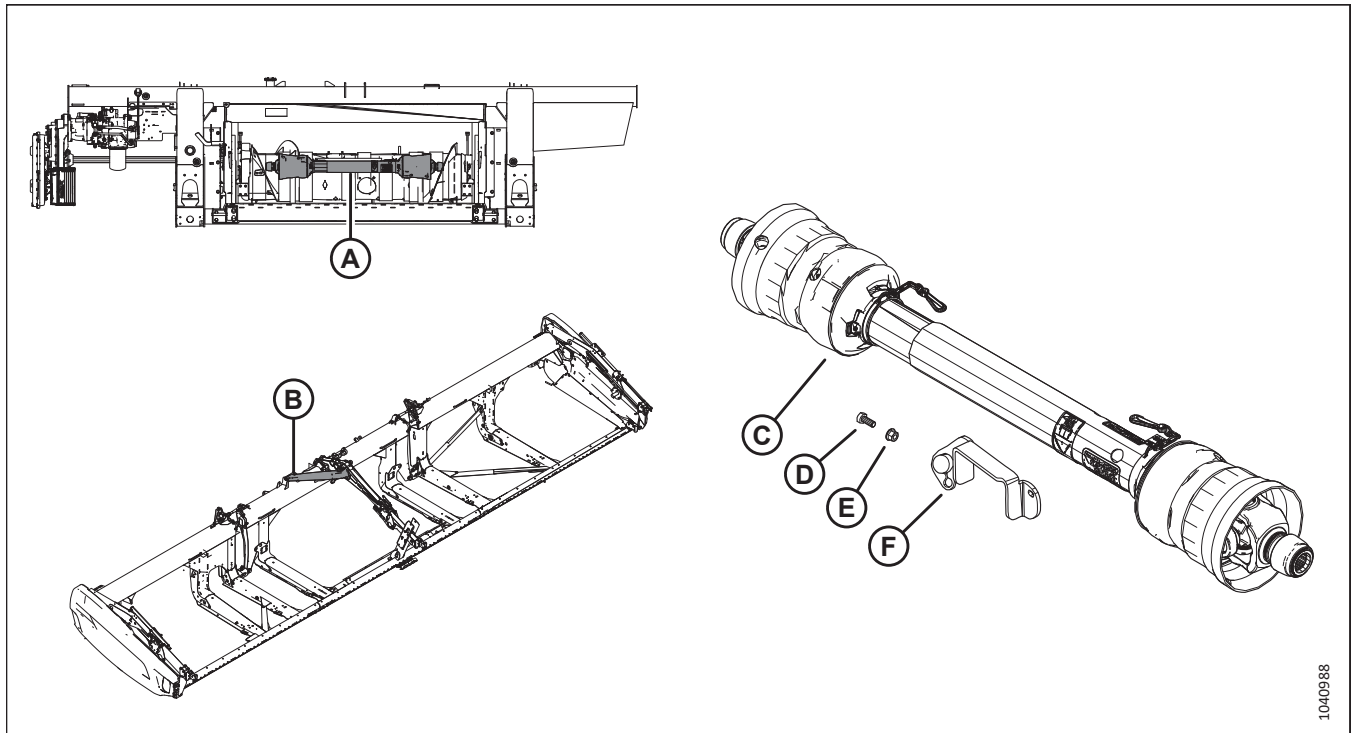
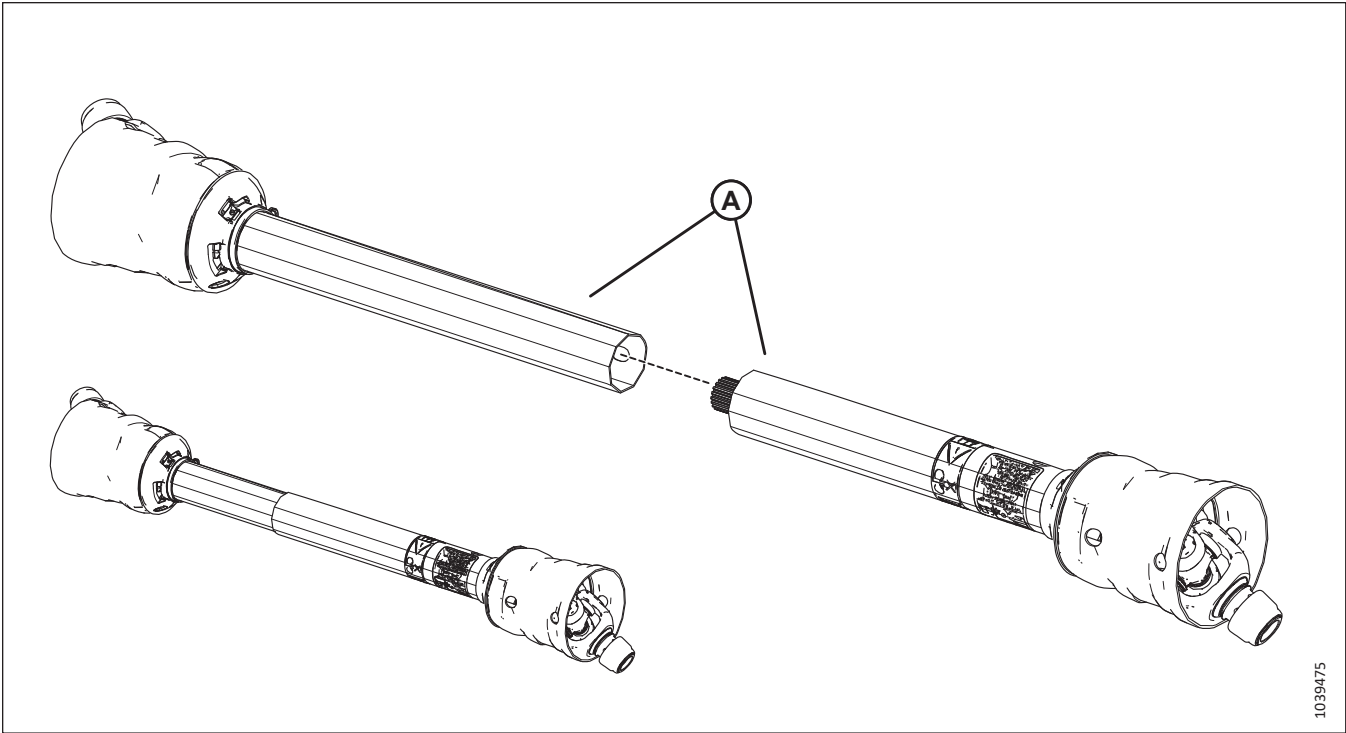

Figure 3.12: Driveline Shipping Locations and Driveline Parts

1. Retrieve the following driveline parts from that are shipped packaged on feed auger (A) (excluding B7326) or reel arm brace (B):
 - Driveline (C) (shipped in two halves for B7326)
 - M10 x 1.5 x 25 mm bolt (D)
 - M10 nut (E)
 - Driveline storage support (F)

SETTING UP FLOAT MODULE



1039475

Figure 3.13: Driveline B7326 Assembly

2. **B7326:** Join driveline halves (A).

NOTE:

The driveline halves are phased. There is only one way to join them.

SETTING UP FLOAT MODULE

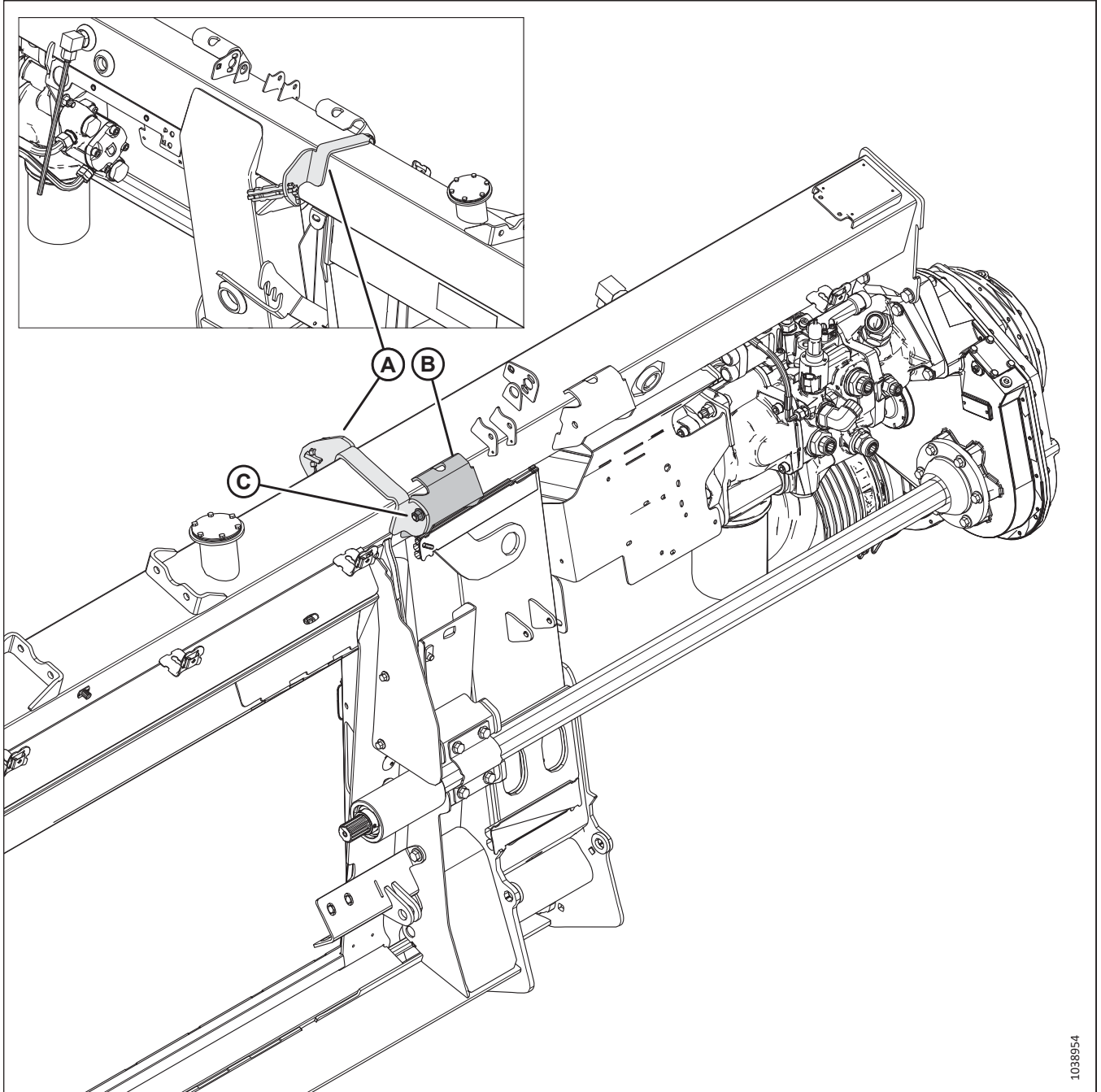

Figure 3.14: Driveline Support on Float Module – View from Behind

3. Attach driveline storage support (A) to bracket (B) using one M10 bolt and nut (C).

SETTING UP FLOAT MODULE

4. On the completion gearbox, pry clips (A) off of shield (B). Remove the shield.

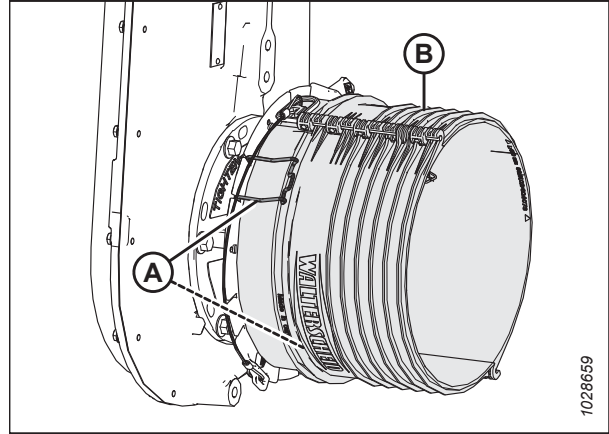

Figure 3.15: Driveline Shield on Float Module Gearbox

NOTE:

Ensure that the arrow on the driveline decal points toward the combine. The appearance of the decal on the driveline varies.



Figure 3.16: Sample Driveline Decal

5. Slide shield (A) onto the driveline.
6. Pull back collar (B). Slide the quick disconnect yoke onto the shaft on the float module's gearbox until the yoke locks onto the shaft. Release the collar.

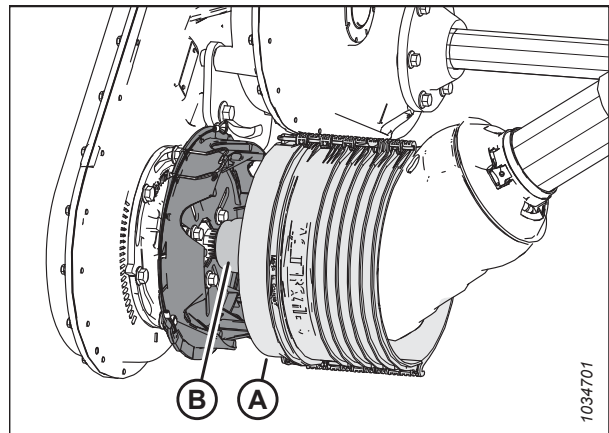

Figure 3.17: Driveline Installed on Float Module Gearbox Shaft

SETTING UP FLOAT MODULE

- Secure shield (A) with clips (B).

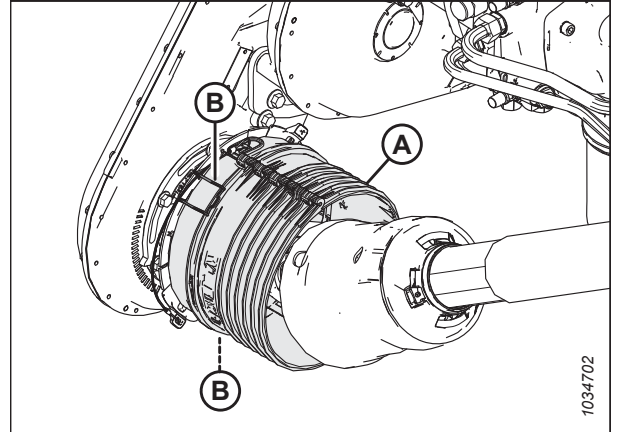

Figure 3.18: Driveline with Shield Installed on Float Module Gearbox Shaft

- Secure the loose end of safety chain (A) to the ear on the aluminum plate as shown.

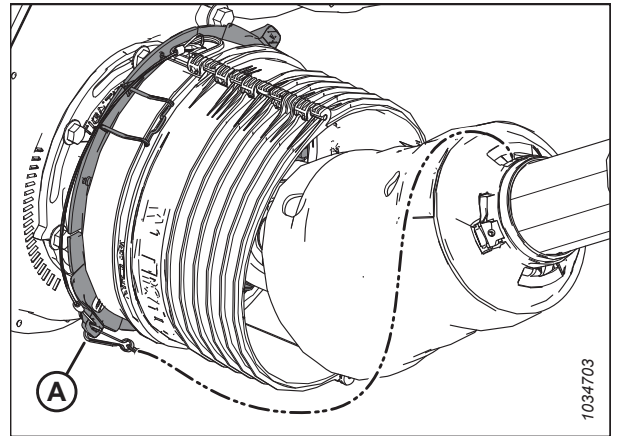

Figure 3.19: Driveline Safety Chain Secured to Float Module Gearbox

- Pull back the collar on driveline (A). Slide driveline (A) yoke onto the shaft on storage support (B) until the yoke locks onto the shaft. Release the collar.
- Secure the loose end of safety chain (C) to the driveline storage support.

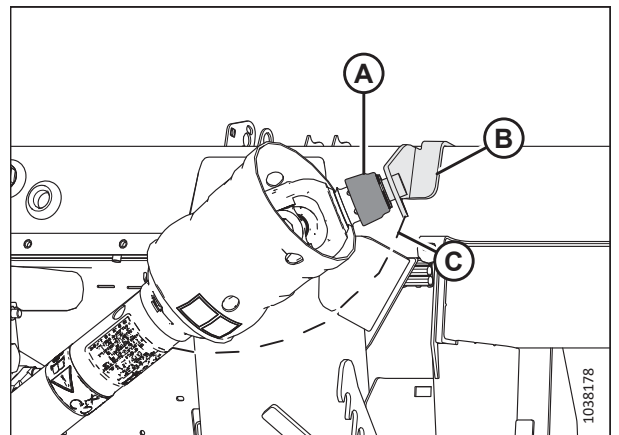

Figure 3.20: Sidehill Driveline in Storage Position on Float Module

3.4 Installing Filler Cap (Unmarked Parts Bag)

The filler cap will need to be installed on the filler neck on the top of the float module.

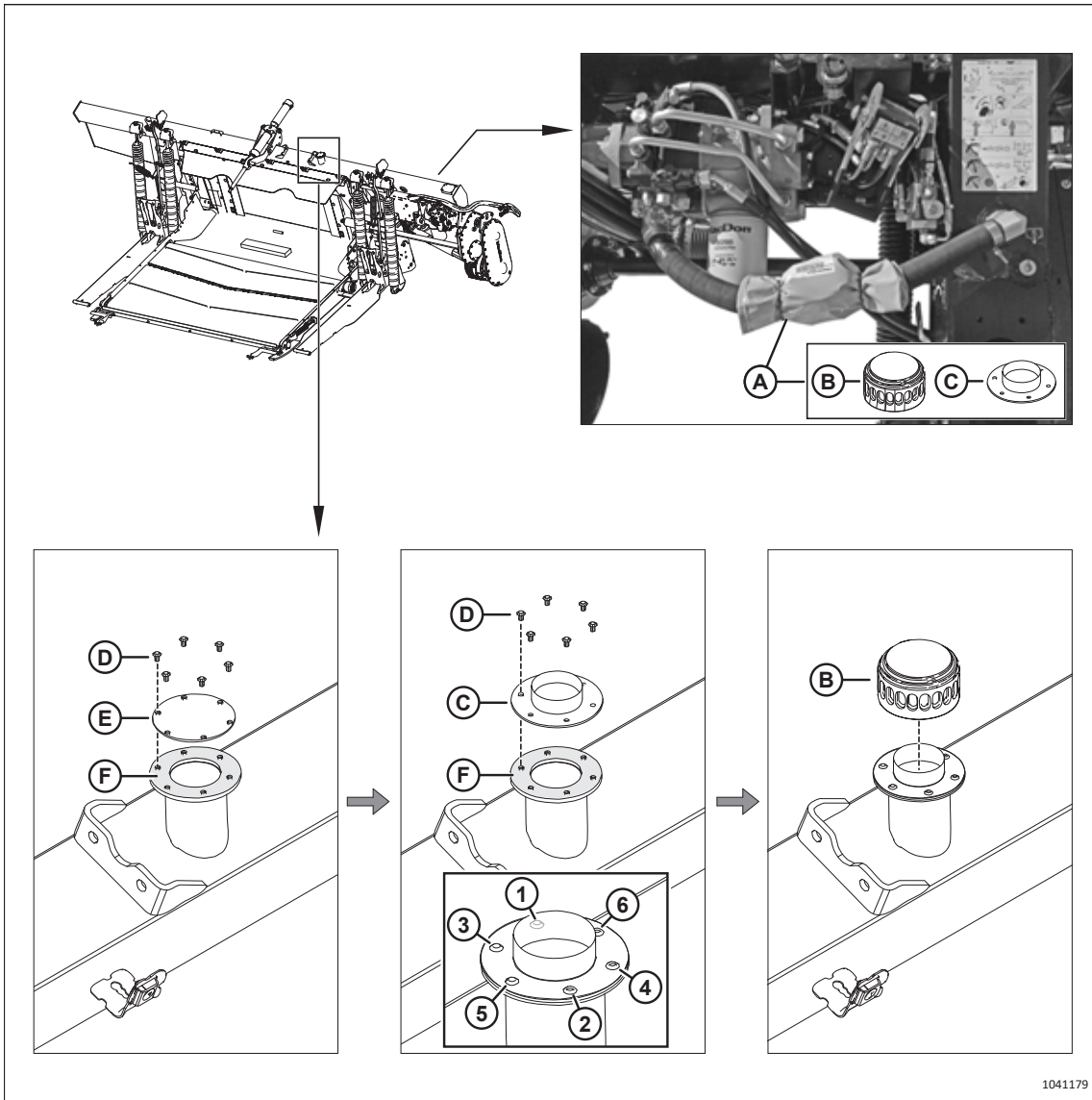

Figure 3.21: Filler Cap Installation

1. Retrieve package (A), which contains cap (B) and bayonet (C).

CAUTION

Hydraulic fluid may be under pressure. Relieve the pressure by loosening the screws and slowly moving the shipping cover away from you.

2. Remove and retain six screws (D). Discard cover (E). Leave gasket (F) in place.
3. Seat bayonet (C) onto gasket (F). Secure the bayonet using six screws (D).
4. Tighten the screws in the order shown (1–6).
5. Screw cap (B) onto the bayonet.

3.5 Installing Cab Control Kits (Parts Bags MD #337619 or 337627)

Cab control kits supply the parts needed for the combine to control certain header features.

NOTE:

Skip this procedure if the float module is configured for any of the following combines:

- Case
- CLAAS
- John Deere X9 Series
- New Holland

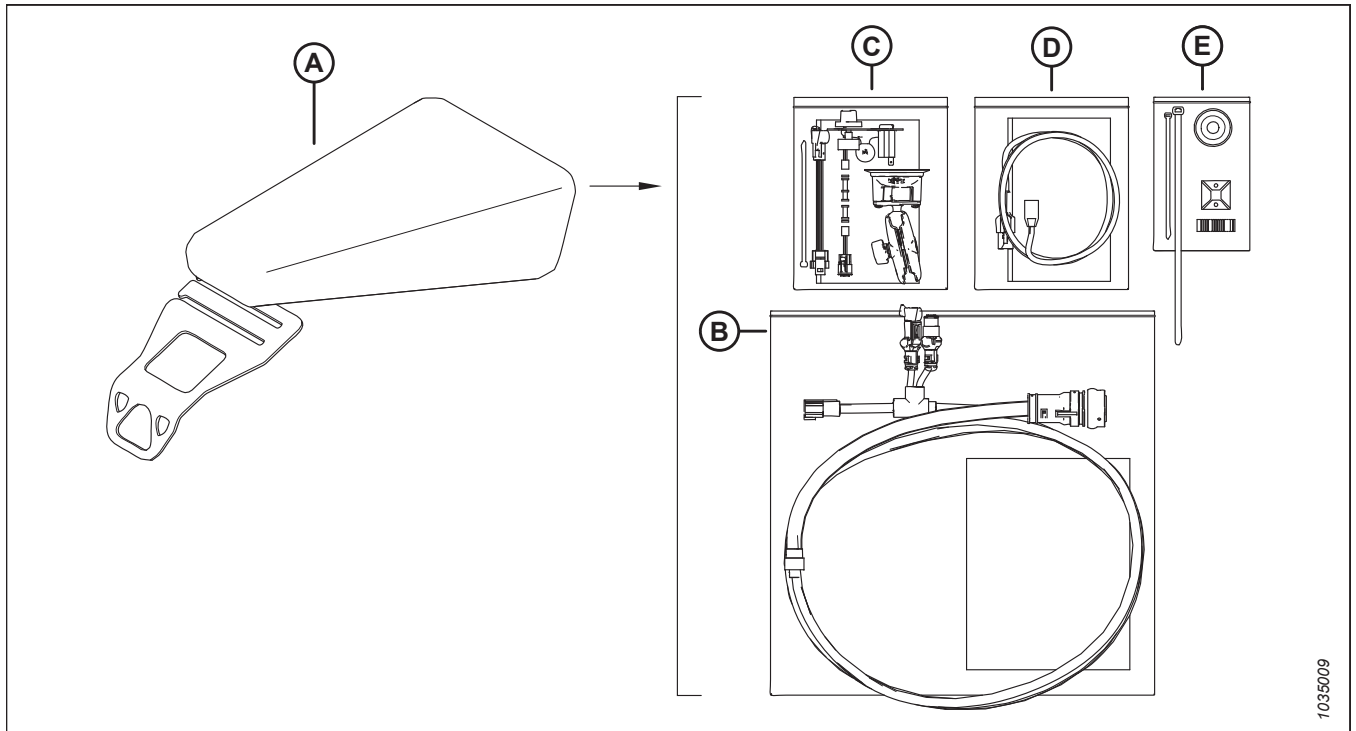

Figure 3.22: John Deere Cab Control Kit MD #337619 – Other Combines Similar

1. Retrieve parts bag (A) that contains the cab control kits. The parts bag is labeled with one of the following numbers:
 - MD #337619 (John Deere excluding X9)
 - MD #337627 (AGCO brands, or if the header is shipped not configured for any brand of combine)
2. Separate instructions are supplied with the kits. Follow the instructions supplied with each kit to install them:
 - Combine Cab Control Harness kit (B)
 - In-Cab Side Draper Speed Control kit (C)
 - Combine Cab Power kits (D)
 - Supplementary parts (E)

3.6 Retrieving Limiter Link – CLAAS Lexion Combines

One limiter link is shipped with float modules configured for CLAAS combines, but is to be installed on CLAAS Lexion 5/6/7/8000 series and TRION series combines only. The limiter link prevents interference between the float module and the combine feeder house dust blower shroud.

⚠ DANGER

Ensure that all bystanders have cleared the area.

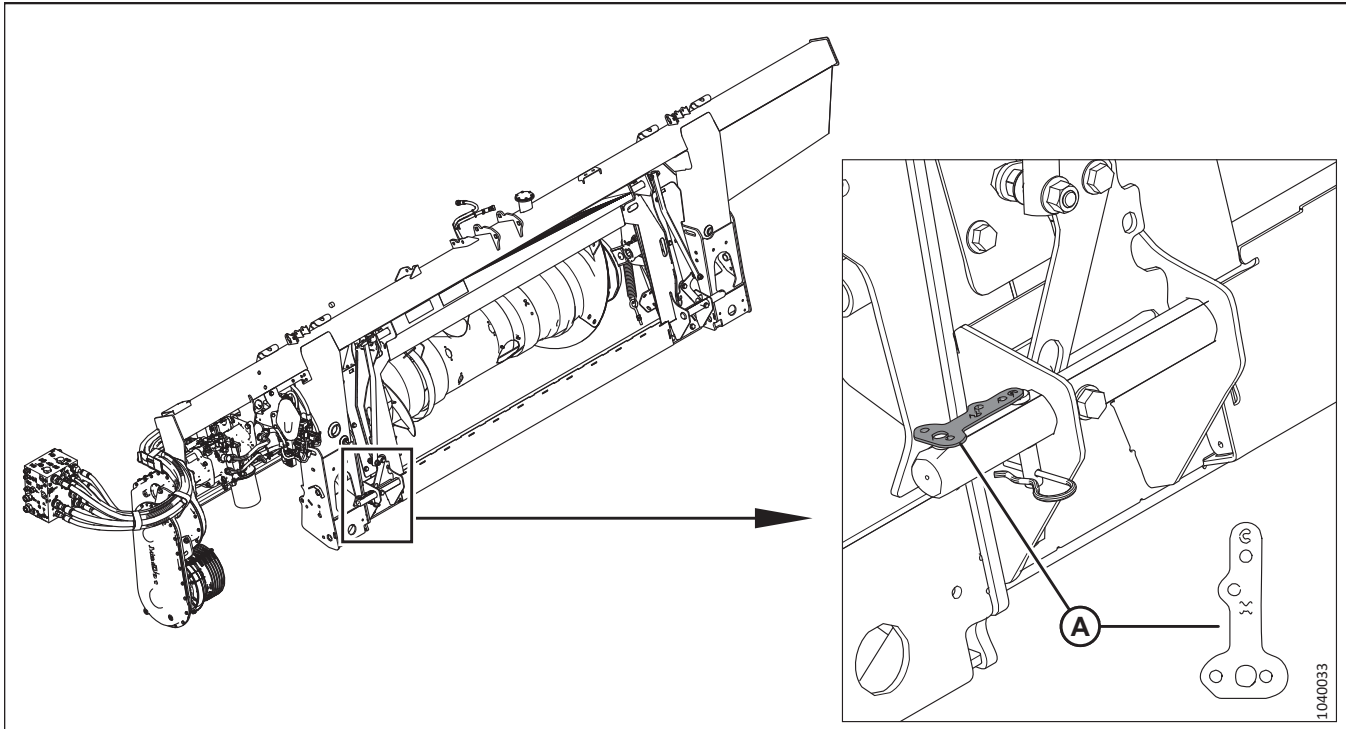

Figure 3.23: Limiter Link Shipping Position

Retrieve limiter link (A) from its shipping position. Proceed as follows:

- If the customer’s combine is **NOT** a CLAAS Lexion 5/6/7/8000 series or TRION series combine, then discard the limiter link, and proceed to [4.3 Attaching Header to CLAAS Combine, page 62](#).
- If customer’s combine is a CLAAS Lexion 5/6/7/8000 series or TRION series combine, then retrieve the customer’s combine (the combine that will operate the header regularly). The limiter link is intended for that combine only. Do **NOT** attach the header to the combine. Proceed to [4.3.1 Installing Limiter Link and Performing a Fore/Aft Tilt Calibration – CLAAS Lexion 5/6/7/8000 Series and TRION Series, page 67](#).

3.7 Retrieving Two-Position Adjustment Plates – John Deere X9 Series Combines

Two adjustment plates have to be retrieved from their shipping location on the float module before the header can be attached to the combine.

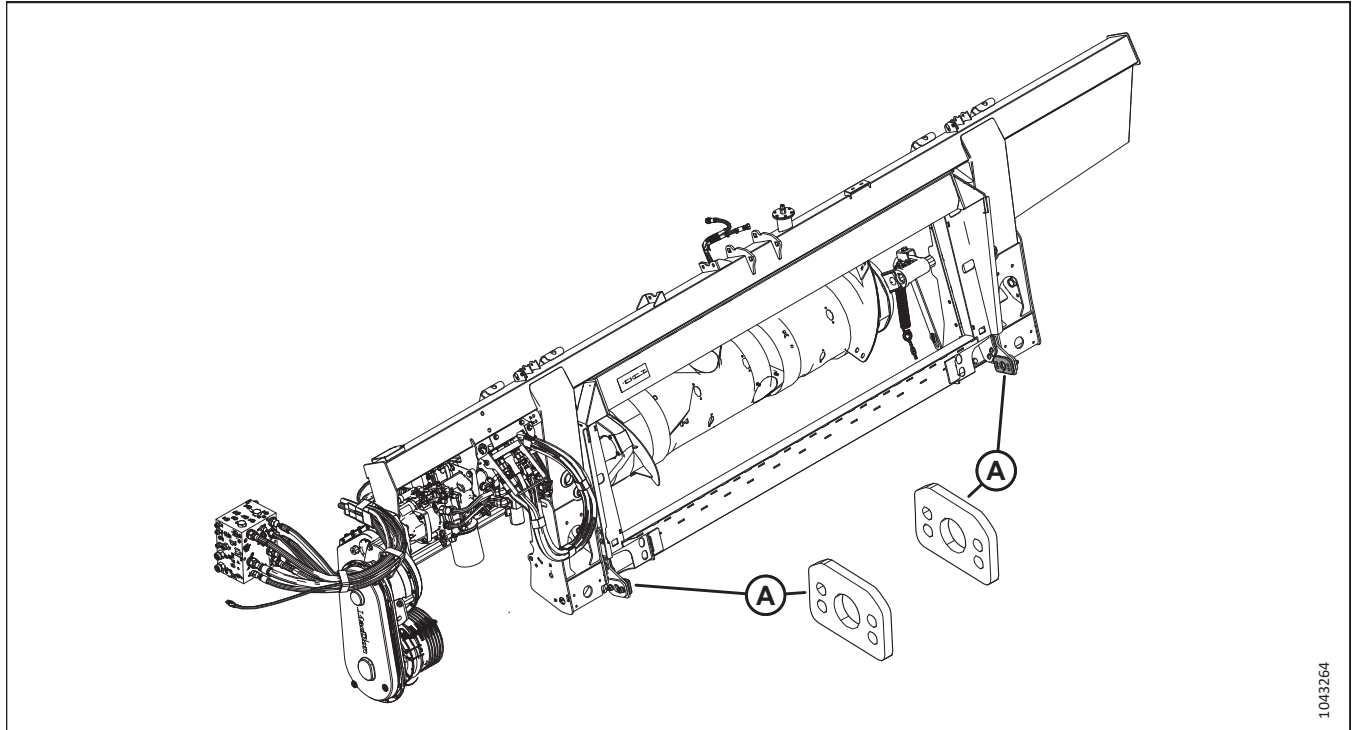

Figure 3.24: John Deere X9 Series Float Module

Retrieve both two-position adjustment plates (A) that are wired to the transition frame anchor plates. Set the plates aside.

- The two-position adjustment plates might be necessary when attaching the header to the combine.
- Make sure the owner of the header receives the adjustment plates.

Chapter 4: Attaching Header to Combine

The header will need to be attached to the combine for further assembly and testing.

The procedures for attaching the header to a combine vary depending on the combine model. Refer to the relevant procedure:

Table 4.1 Combine Model Header Attachment Procedures

Combine	Refer to
Case IH Models: 5/6/7088, 7/8010, 7/8/9120, 130, 140, 150, 230, 240, 250 Series Case IH Models: 21XX/23XX/25XX	4.1 Attaching Header to Case IH Combine, page 52
Challenger® 66/67/680B, 540C/560C Gleaner® A-Series Models: A66/76/86 Gleaner® R-Series & Super-Series Models: R65/75, R66/76, S67/77, S68/78/88, S96/97/98 Massey Ferguson® 9520/40/50, 9695/9795/9895	4.2 Attaching Header to Challenger®, Gleaner®, or Massey Ferguson® Combine, page 57
CLAAS/CAT-Lexion Models: 560/570/580/590R, 575/585/595R, 600 CLAAS Lexion 600 and 700 Series Models: 6X0 and 7X0 CLAAS Lexion 5/6/7/8000 Series and Models: 5X00, 6X00, 7X00, 8X00 CLAAS Lexion TRION Series	4.3 Attaching Header to CLAAS Combine, page 62
IDEAL™ (Massey Ferguson®, Fendt®, and Valtra®) Models: 7, 8, 9, 10	4.4 Attaching Header to IDEAL™ Series Combine, page 72
John Deere T, 60/70 and S-Series Models: T5X0, T6X0, 9X60, 9X70, S6X0, S7X0 John Deere X9 Series	4.5 Attaching Header to John Deere Combine, page 76
New Holland CR Models: CR 9X0, 90X0, X090, X080, X.90, X.80 New Holland CX Models: CX 8X0, 80X0, 8.X0 New Holland CH Model: CH7.70	4.6 Attaching Header to New Holland CR, CX, or CH Combine, page 84
Rostselmash 161, T500, and TORUM 785	4.7 Attaching Header to Rostselmash Combine, page 89

IMPORTANT:

Ensure that the applicable functions (for example: automatic header height control [AHHC], draper header option, hydraulic center-link option, hydraulic reel drive) are enabled on the combine and in the combine's computer. Failure to do so may result in improper header operation.

NOTE:

Ensure that the combine feeder house's lugs are free of dirt and debris. Check the locking mechanism for freedom of movement, and ensure that it is free of damage; make any necessary repairs to the locking mechanism prior to attaching the header to the combine.

NOTE:

Ensure that all electrical and hydraulic connectors are clean and free of dust and debris.

4.1 Attaching Header to Case IH Combine

The header will need to be physically connected to the combine's feeder house, and the electrical and hydraulic connections completed.

DANGER

To prevent injury or death from the unexpected start-up of the machine, always stop the engine and remove the key from the ignition before leaving the operator's seat for any reason.

DANGER

Ensure that all bystanders have cleared the area.

IMPORTANT:

If the combine is **NOT** equipped with a rock trap, feeder house faceplate (A) **MUST** be in mid-position (B). For instructions on adjusting the faceplate, refer to the combine operator's manual.

NOTE:

A rock trap prevents rocks or debris from entering the combine, and is located on the front of the combine and behind the feeder house.

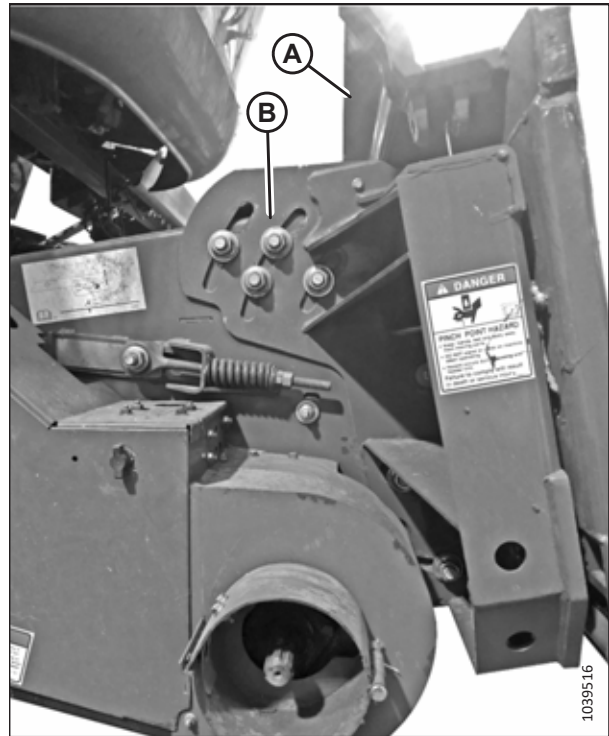

Figure 4.1: Faceplate Tilted to Mid-Position on Unspecified Combine

1. Shut down the engine, and remove the key from the ignition.

ATTACHING HEADER TO COMBINE

2. On the combine, ensure that lock handle (A) is positioned so hooks (B) can engage the float module.

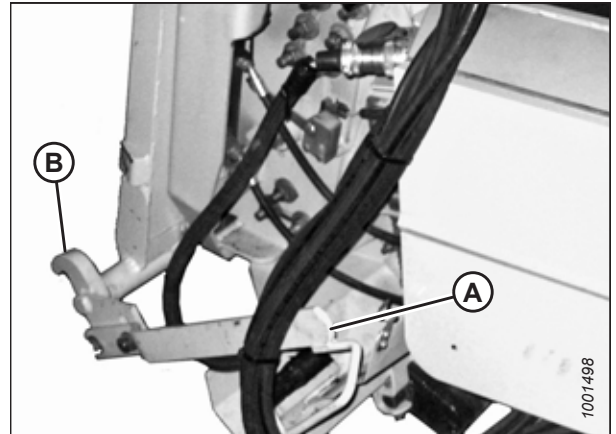

Figure 4.2: Feeder House Locks

3. Slowly drive the combine up to the header until feeder house saddle (A) is directly under float module top cross member (B).
4. Raise the feeder house slightly to lift the header. Ensure that the feeder saddle is properly engaged in the float module's frame.
5. Shut down the engine, and remove the key from the ignition.

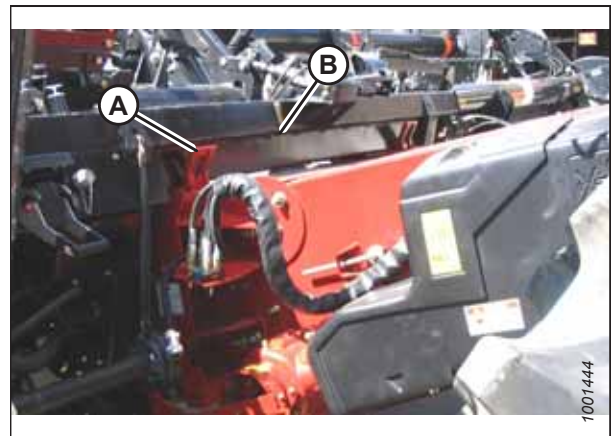

Figure 4.3: Combine and Float Module

6. On the left side of the feeder house, lift lever (A) on the float module and push handle (B) on the combine to engage locks (C) on both sides of the feeder house.
7. Push lever (A) down so that the slot in the lever locks the handle.
8. If lock (C) does not fully engage the pin on the float module, loosen bolts (D) and adjust the lock. Retighten the bolts.

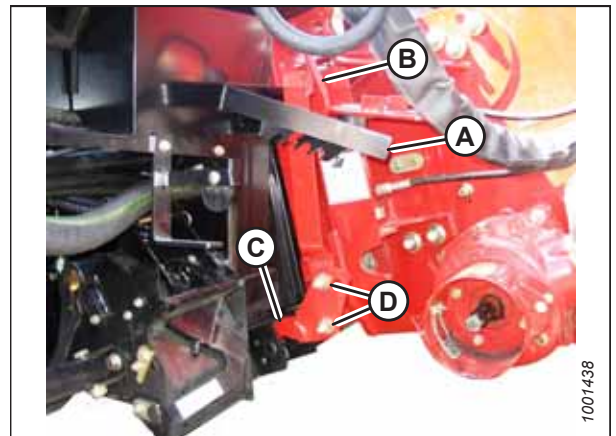

Figure 4.4: Combine and Float Module

ATTACHING HEADER TO COMBINE

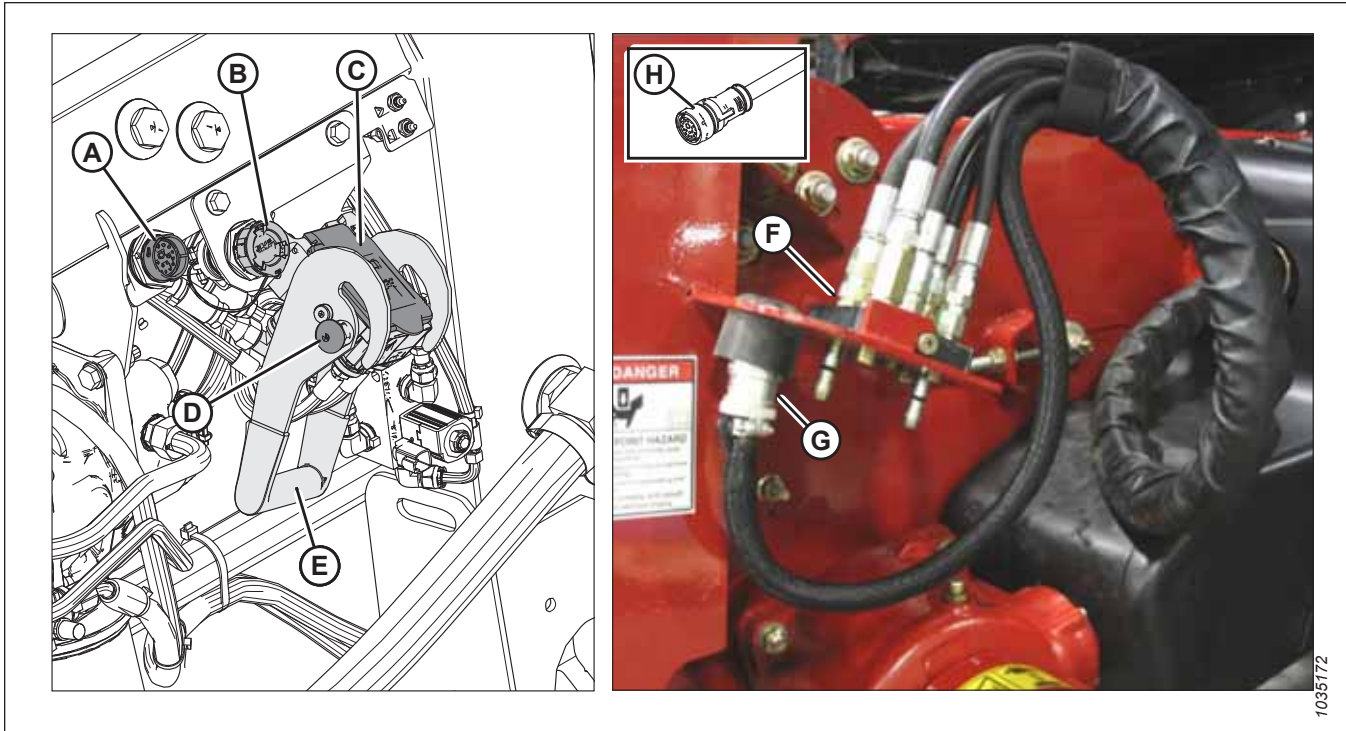

Figure 4.5: Multicoupler and Electrical Connections

9. **If MacDon in-cab controls are installed:** Remove the cap from connector C81B (A).
10. Remove the cap from connector C72B (B).
11. Remove the cover from hydraulic receptacle (C). Clean the receptacle mating surfaces.
12. Push in lock button (D) and pull handle (E) to the fully open position.
13. Remove hydraulic quick coupler (F) from the storage plate on the combine. Clean the mating surface of the coupler.
14. Position coupler (F) onto float module receptacle (C), and push handle (E) to engage the pins into the receptacle.
15. Push handle (E) to the closed position until lock button (D) snaps out.
16. Remove combine connector (G) from its storage location on the combine and connect it to receptacle C72B (B). Turn the collar on the connector to lock it in place.
17. **If MacDon in-cab controls are installed:** Remove cab control kit connector C81A (H) from its storage location on the combine and connect it to C81B (A). Turn the collar on the connector to lock it in place.

ATTACHING HEADER TO COMBINE

18. Pull driveline collar (A) back to release the driveline from the support bracket. Remove the driveline from the support bracket.

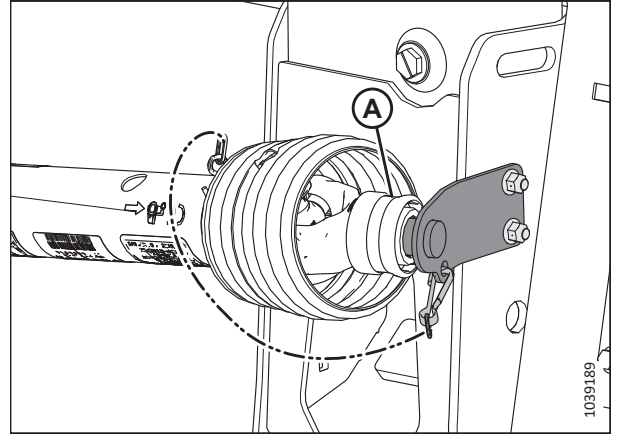

Figure 4.6: Driveline in Storage Position – Driveline B7038 or B7039

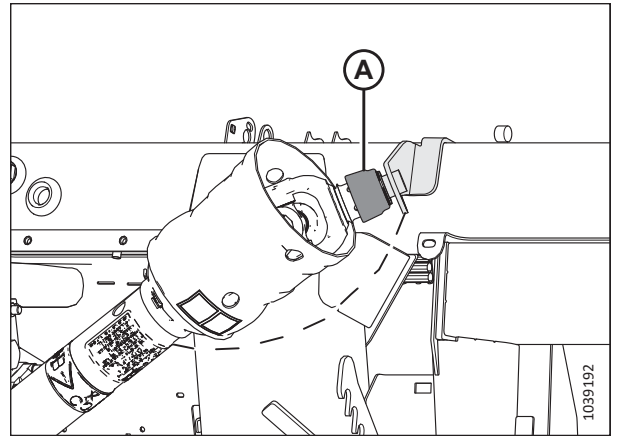

Figure 4.7: Driveline in Storage Position – Sidehill/Hillside Driveline B7180, B7181, or B7326

19. Pull back collar (A) on the end of the driveline. Push the driveline onto combine output shaft (B) until the collar locks.

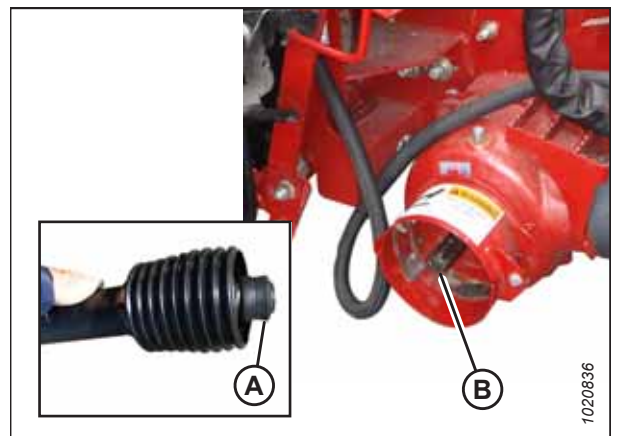

Figure 4.8: Combine Output Shaft

ATTACHING HEADER TO COMBINE

20. Proceed as follows:

- If the header is going to be used in the field now, disengage the float locks by pulling each float lock handle (A) away from the float module and into unlocked position (B).
- If the header is **NOT** going to be used in the field now, engage the float locks by pushing each float lock handle (A) toward the float module and into locked position (C).

NOTE:

The illustration shows the float lock handle on the right side of the header. The float lock handle on the left side of the header is the opposite.

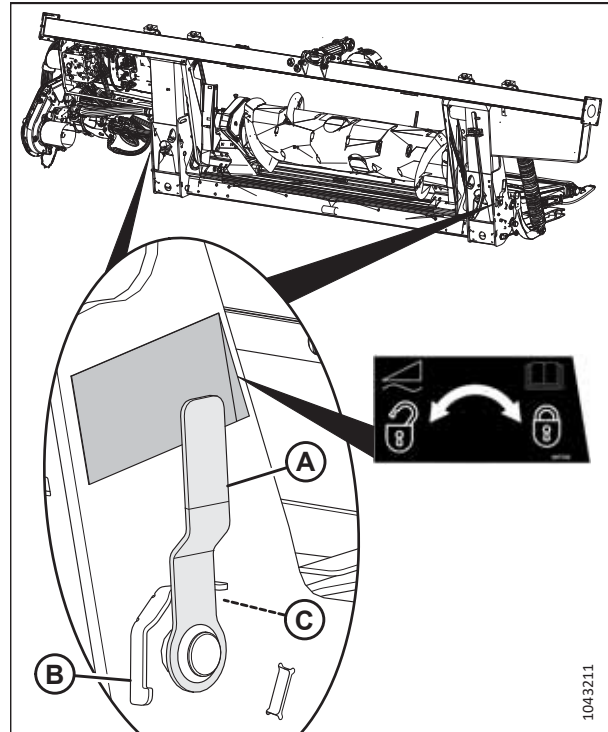

Figure 4.9: Float Lock Handle

4.2 Attaching Header to Challenger®, Gleaner®, or Massey Ferguson® Combine

The header will need to be physically connected to the combine’s feeder house, and the electrical and hydraulic connections completed.

NOTE:

The float module is equipped with a multicoupler that connects to the combine. If the combine is equipped with individual connectors, a multicoupler kit (single-point connector) must be installed. Refer to Table 4.2, page 57 for a list of needed kits.

Table 4.2 Multicoupler Kits

Combine	AGCO Kit Number
Challenger®	71530662
Gleaner® R/S Series	71414706
Massey Ferguson®	71411594

⚠ DANGER

To prevent injury or death from the unexpected start-up of the machine, always stop the engine and remove the key from the ignition before leaving the operator’s seat for any reason.

⚠ DANGER

Ensure that all bystanders have cleared the area.

IMPORTANT:

If the combine is **NOT** equipped with a rock trap, feeder house faceplate (A) **MUST** be in mid-position (B). For instructions on adjusting the faceplate, refer to the combine operator’s manual.

NOTE:

A rock trap prevents rocks or debris from entering the combine, and is located on the front of the combine and behind the feeder house.

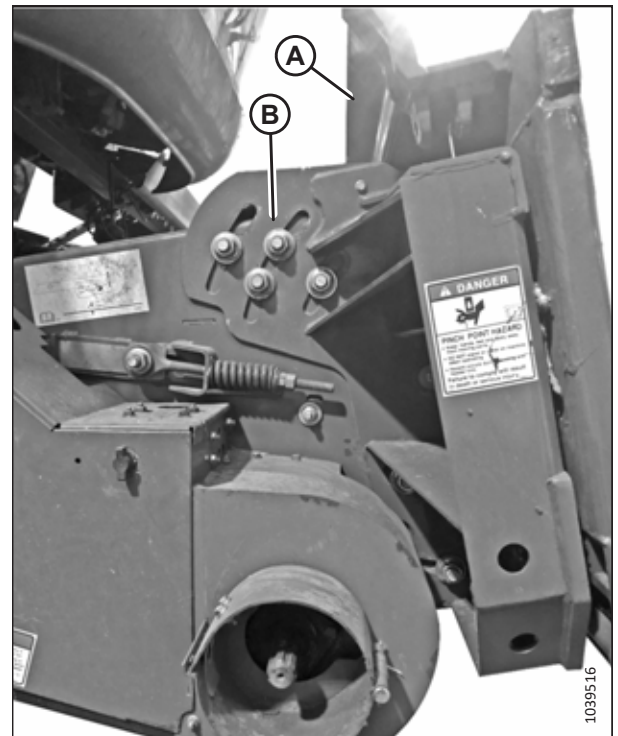

Figure 4.10: Faceplate Tilted to Mid-Position on Unspecified Combine

ATTACHING HEADER TO COMBINE

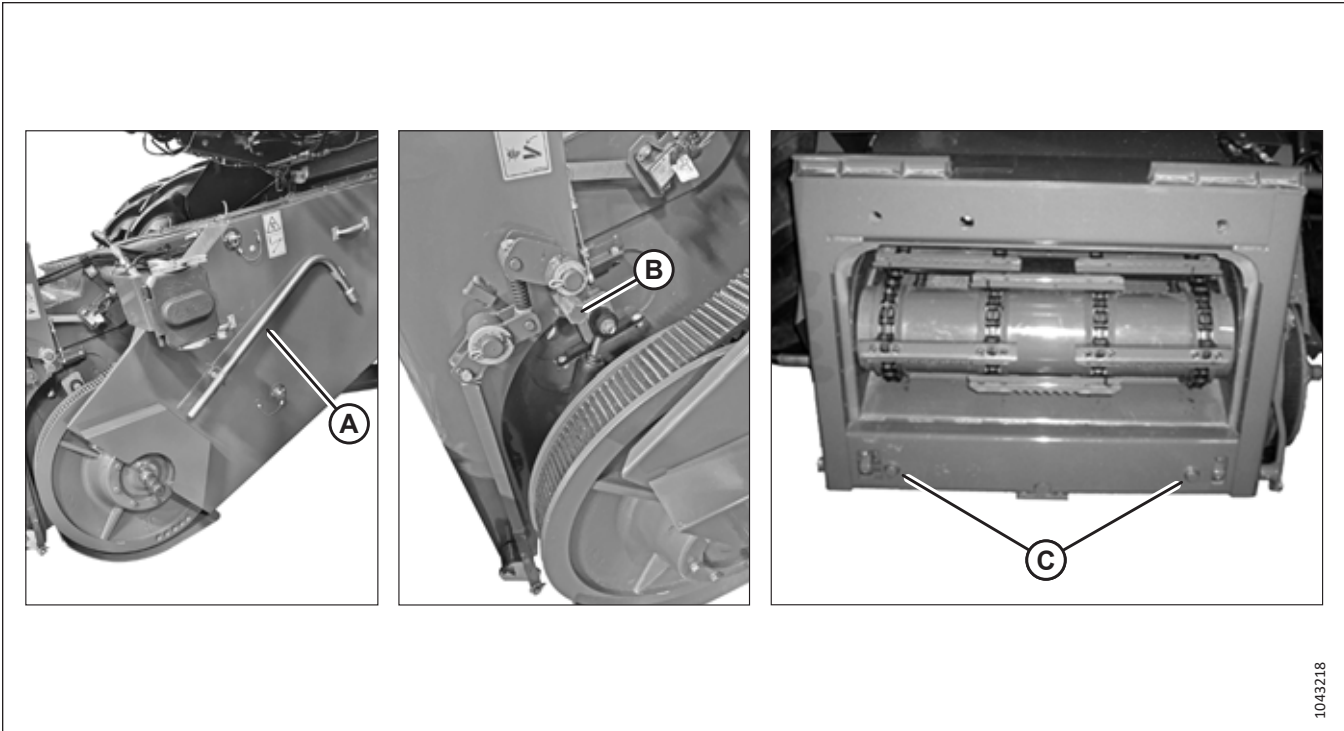

Figure 4.11: Feeder House

1. Shut down the engine, and remove the key from the ignition.
2. Retrieve feeder house tool (A) and install it onto latch bolt (B). Retract feeder house pins (C) by operating the latch.

NOTE:

The combine feeder house may not be exactly as shown. If the latch mechanism is different than what is described in this procedure, refer to the combine operator's manual for instructions.

3. Slowly approach the header until the feeder house is directly under float module top cross member (A).

NOTE:

Ensure that alignment pins (C) (refer to Figure 4.11, page 58) on the feeder house align with holes (B) in the float module frame.

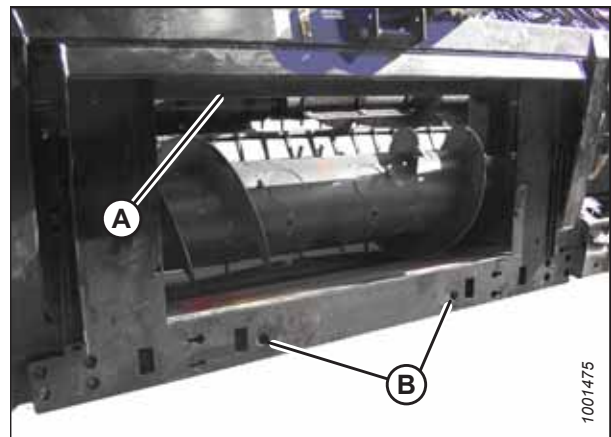

Figure 4.12: Float Module

ATTACHING HEADER TO COMBINE

4. Raise the feeder house slightly to lift the header, ensuring feeder house saddle (A) is properly engaged in the float module frame.
5. Shut down the engine, and remove the key from the ignition.

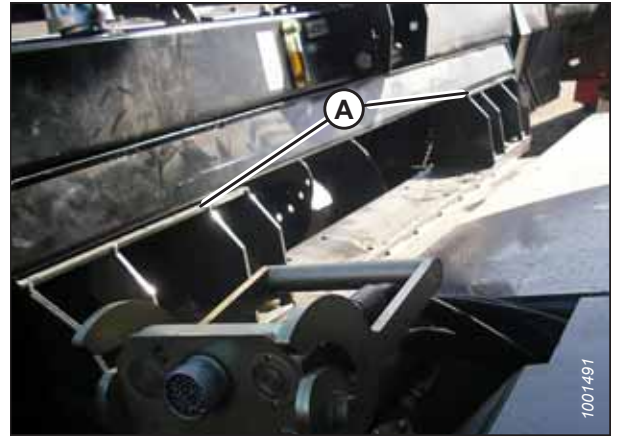

Figure 4.13: Feeder House and Float Module

6. Use latch mechanism (B) to engage pins (A) with the float module.

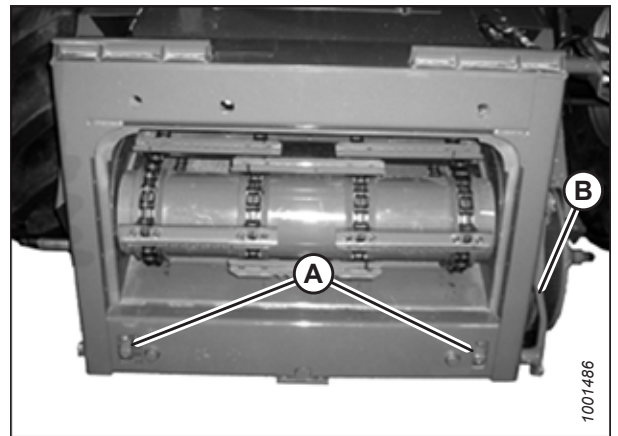

Figure 4.14: AGCO Group Feeder House

ATTACHING HEADER TO COMBINE

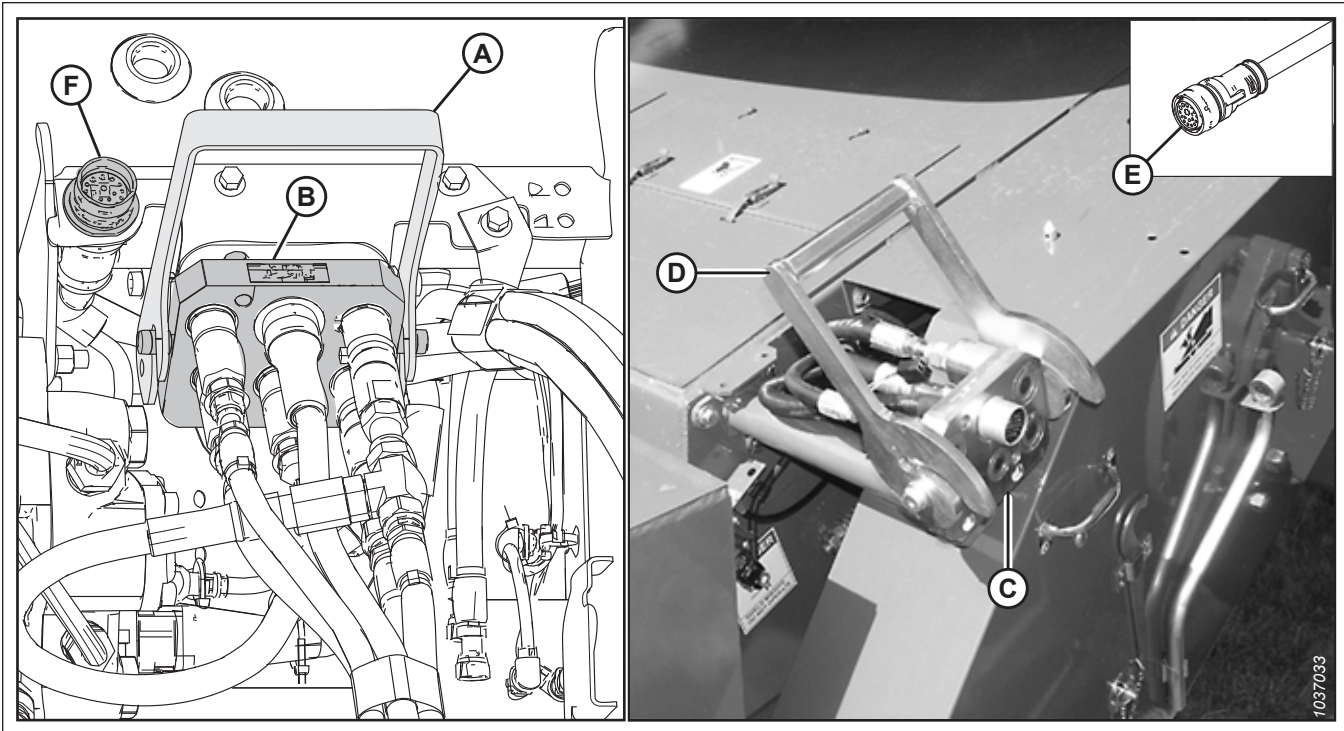

Figure 4.15: Hydraulics and Electrical Multicoupler

7. Raise handle (A) to release multicoupler (B) from the float module.
8. Raise handle (D) on the combine to the fully open position. Clean the mating surfaces of multicoupler (B) and receptacle (C).
9. Install multicoupler (B) into combine receptacle (C). Pull handle (D) to engage the multicoupler into the receptacle.
10. Retrieve cab control kit connector C81A (E) from the storage location on the combine and connect it to connector C81B (F) on the float module. Turn the collar on the connector to lock it.
11. Pull driveline collar (A) back to release the driveline from the support bracket. Remove the driveline from the support bracket.

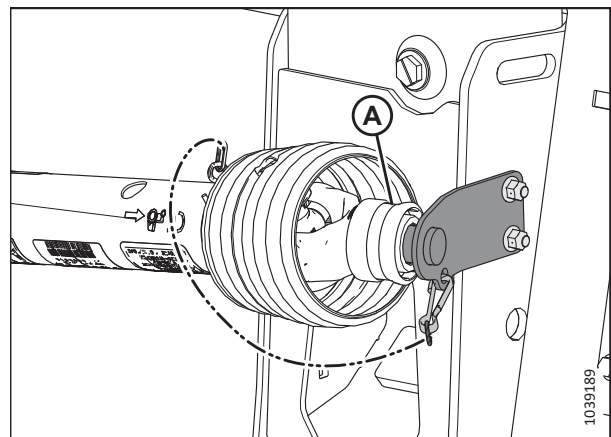

Figure 4.16: Driveline in Storage Position

ATTACHING HEADER TO COMBINE

12. Pull back collar (A) on the end of the driveline, and push the driveline onto combine output shaft (B) until the collar is locked.

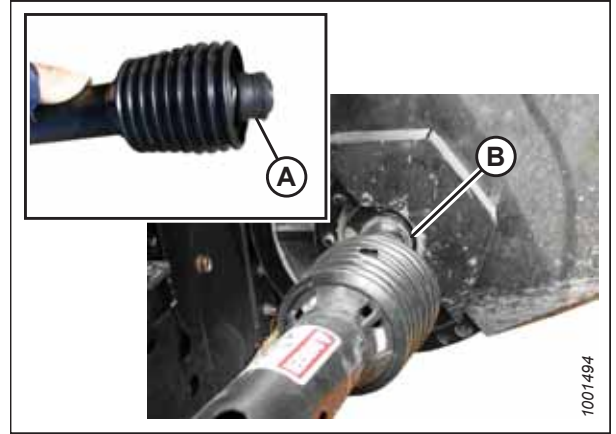

Figure 4.17: Driveline

13. Proceed as follows:

- If the header is going to be used in the field now, disengage the float locks by pulling each float lock handle (A) away from the float module and into unlocked position (B).
- If the header is **NOT** going to be used in the field now, engage the float locks by pushing each float lock handle (A) toward the float module and into locked position (C).

NOTE:

The illustration shows the float lock handle on the right side of the header. The float lock handle on the left side of the header is the opposite.

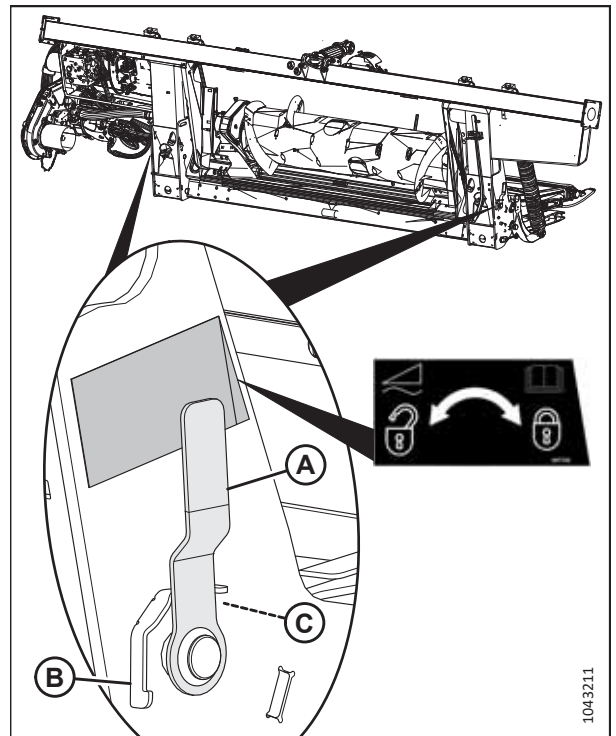

Figure 4.18: Float Lock Handle

4.3 Attaching Header to CLAAS Combine

The header will need to be physically connected to the combine's feeder house, and the electrical and hydraulic connections completed.

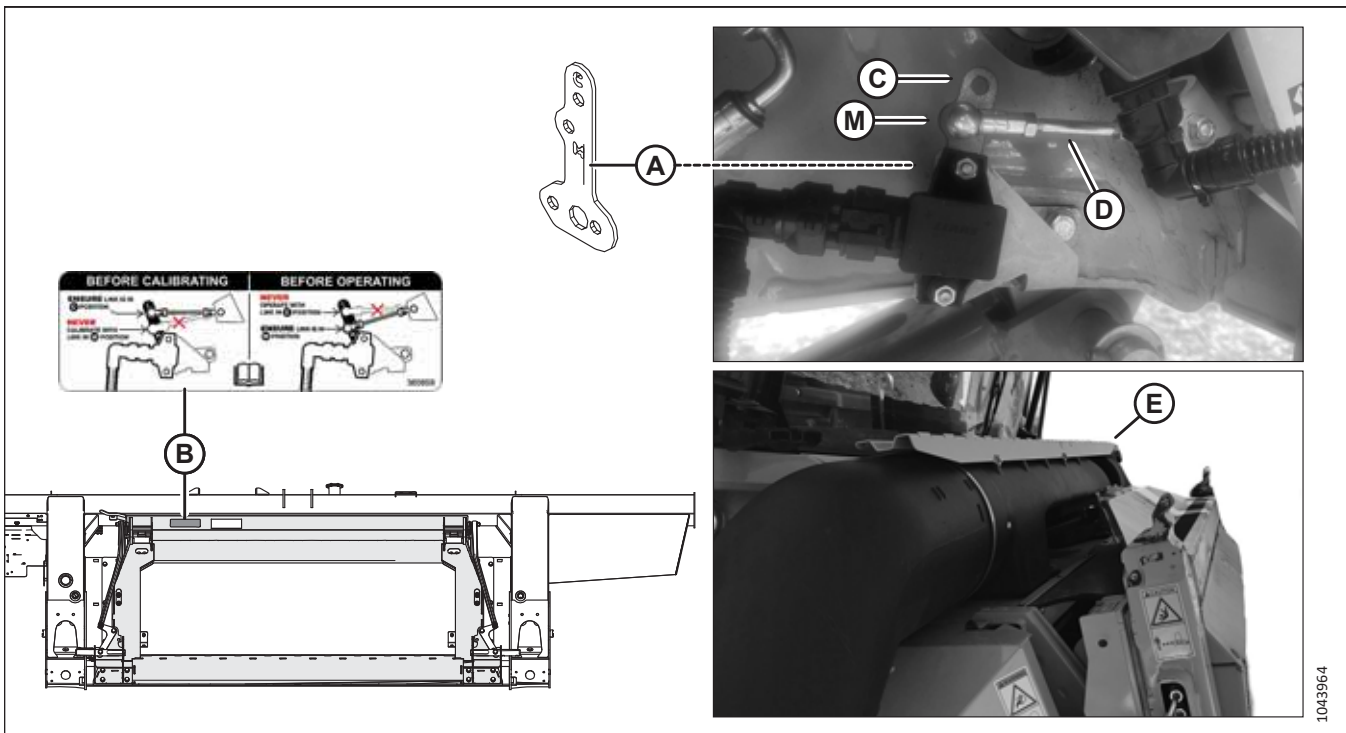

Figure 4.19: Limiter Link, Decal, and Feeder House

IMPORTANT:

Before a CLAAS Lexion 5/6/7/8000 Series or TRION series combine is attached to the header for the first time, fore/aft tilt sensor limiter link (A) (MD #357776) must be installed on the combine's feeder house, and a feeder house fore/aft tilt calibration must be performed. When properly configured, the limiter link prevents interference between the float module and the feeder house dust blower shroud (E).

- The initial installation of the limiter link, and the initial feeder house fore/aft tilt calibration, is done by a Dealer.
- Sensor linkage (D) must be installed in limiter link hole "C" (C), and the header must be detached from the combine, before performing a feeder house fore/aft tilt calibration. Hole "C" is only used for feeder house fore/aft tilt calibrations.
- Sensor linkage (D) must be installed in limiter link hole "M" (M) as shown before attaching the header to the combine. Hole "M" is used for operating the header, or performing any calibration that is **NOT** a feeder house fore-aft tilt calibration. Examples of calibrations that use hole "M" include auto header height control (AHHC), reel height, and reel fore-aft calibrations.
- Decal (B) (MD #360859) is installed on the float module transition frame to remind the operator when the sensor linkage must be installed in hole "C" or hole "M".
- For limiter link installation and feeder house fore/aft tilt calibration instructions, refer to [4.3.1 Installing Limiter Link and Performing a Fore/Aft Tilt Calibration – CLAAS Lexion 5/6/7/8000 Series and TRION Series, page 67](#).

ATTACHING HEADER TO COMBINE

IMPORTANT:

If the combine is **NOT** equipped with a rock trap, feeder house faceplate (A) **MUST** be in mid-position (B). For instructions on adjusting the faceplate, refer to the combine operator's manual.

NOTE:

A rock trap prevents rocks or debris from entering the combine, and is located on the front of the combine and behind the feeder house.

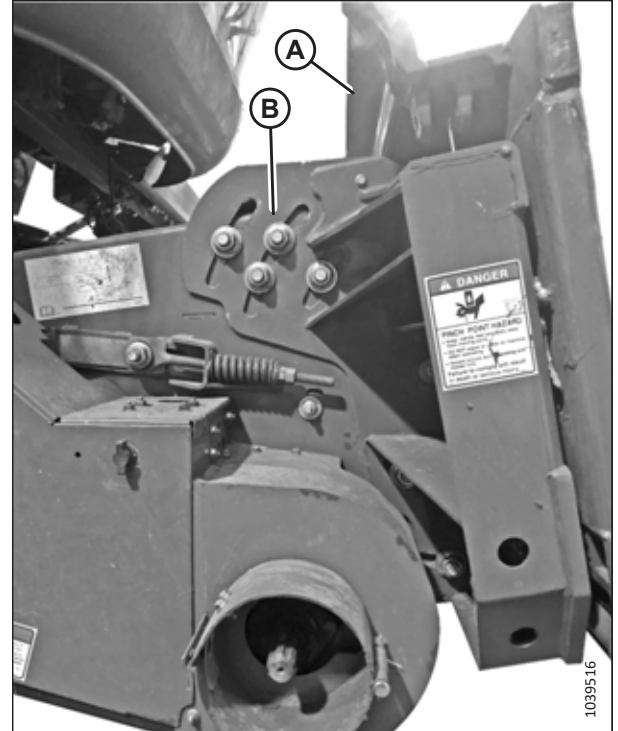

Figure 4.20: Faceplate Tilted to Mid-Position on Unspecified Combine

DANGER

To prevent injury or death from the unexpected start-up of the machine, always stop the engine and remove the key from the ignition before leaving the operator's seat for any reason.

DANGER

Ensure that all bystanders have cleared the area.

1. Shut down the engine, and remove the key from the ignition.
2. Move handle (A) on the float module to the raised position. Ensure that pins (B) at the bottom corners of the float module are retracted.

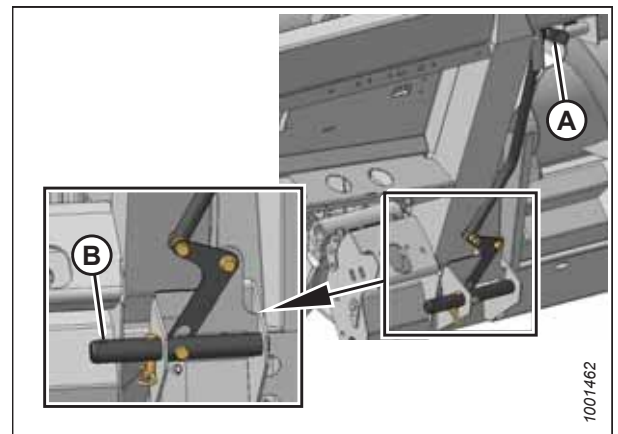

Figure 4.21: Pins Retracted

ATTACHING HEADER TO COMBINE

3. Slowly drive the combine up to the header until feeder house saddle (A) is directly under float module top cross member (B).
4. Raise the feeder house slightly to lift the header. Ensure that the feeder saddle is fully engaged with the float module's frame.
5. Shut down the engine, and remove the key from the ignition.

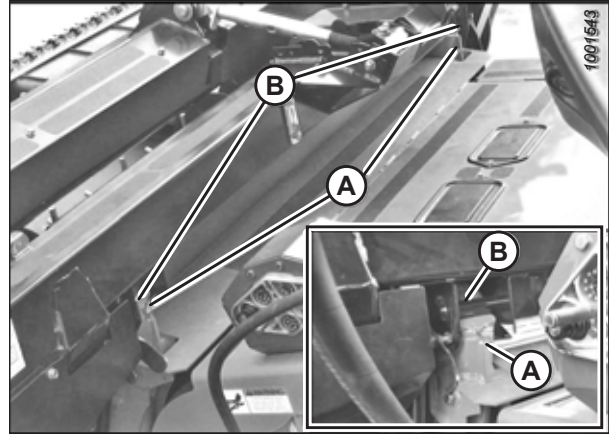

Figure 4.22: Header on Combine

6. Remove locking pin (B) from float module pin (A).

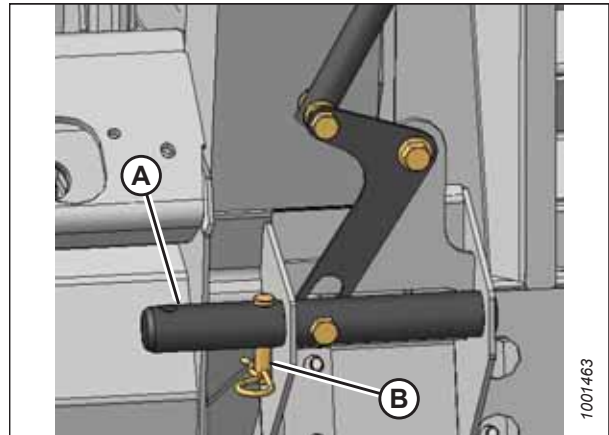

Figure 4.23: Locking Pins

7. Lower handle (A) to engage float module pins (B) into the feeder house. Reinsert locking pin (C) as shown. Secure the locking pin with the hairpin.

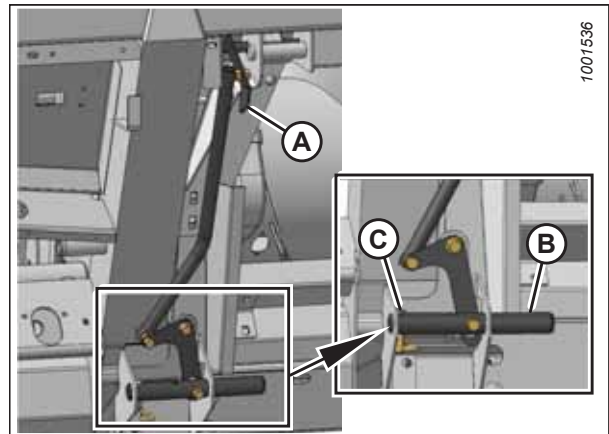

Figure 4.24: Engaging Pins

ATTACHING HEADER TO COMBINE

8. Remove float module receptacle cover (A). Clean the receptacle.

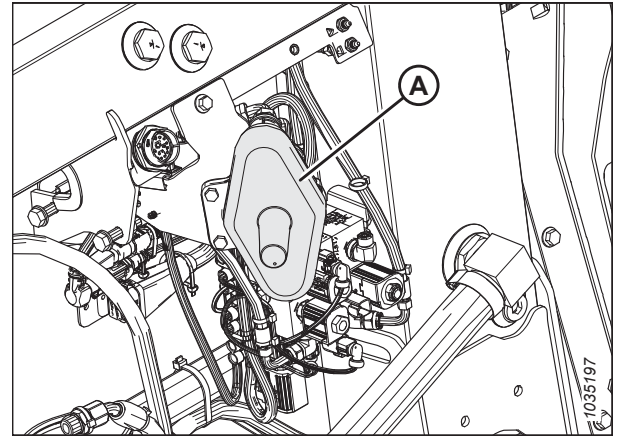

Figure 4.25: Receptacle Cover

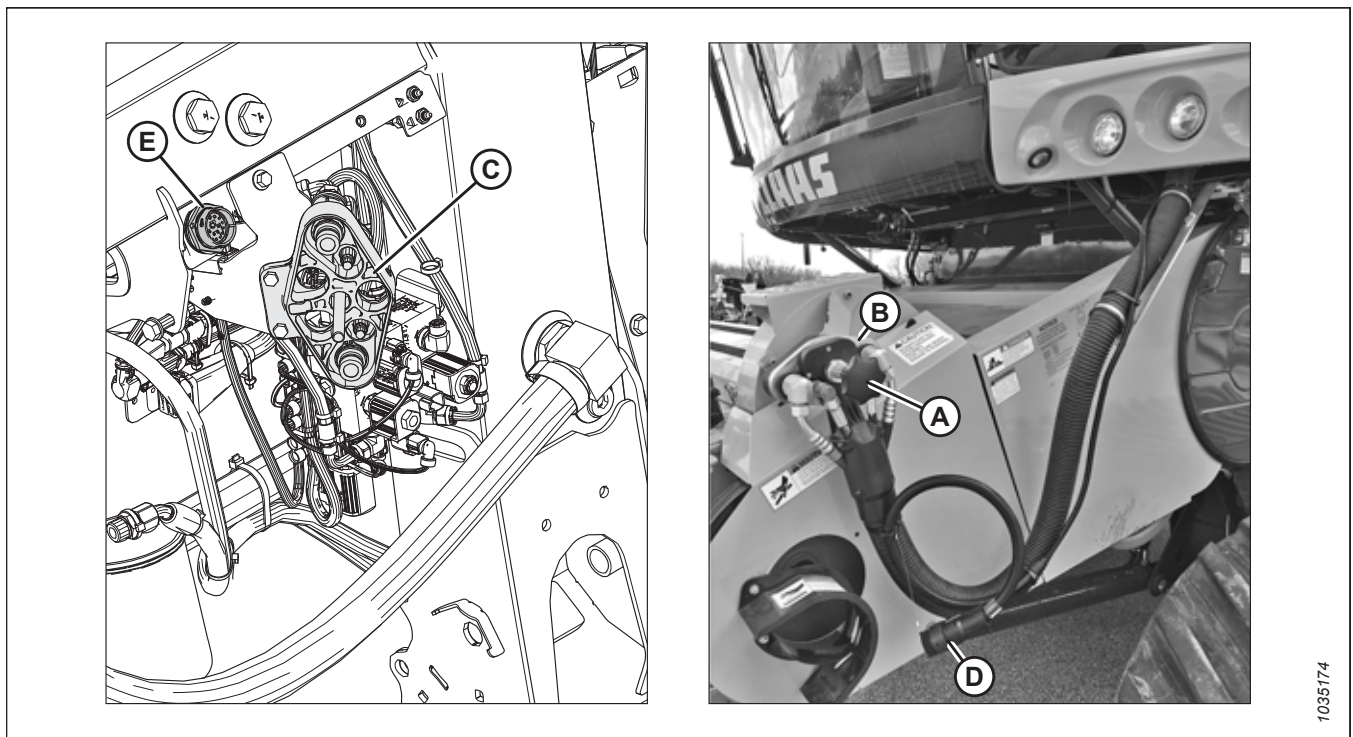

Figure 4.26: Multicoupler and Electrical Connections

9. Unscrew knob (A) on combine coupler (B) to release the coupler from the receptacle.
10. Clean coupler (B) and the receptacle.
11. Install combine coupler (B) onto float module receptacle (C). Secure the coupler by turning knob (A).
12. **If MacDon in-cab controls are installed:** Remove cab control kit connector C81A (D) from the storage location on the combine and connect it to C81B (E) on the float module. Turn the collar on the connector to lock it in place.

ATTACHING HEADER TO COMBINE

- Place float module receptacle cover (A) onto the combine receptacle as shown in Figure 4.27, page 66.

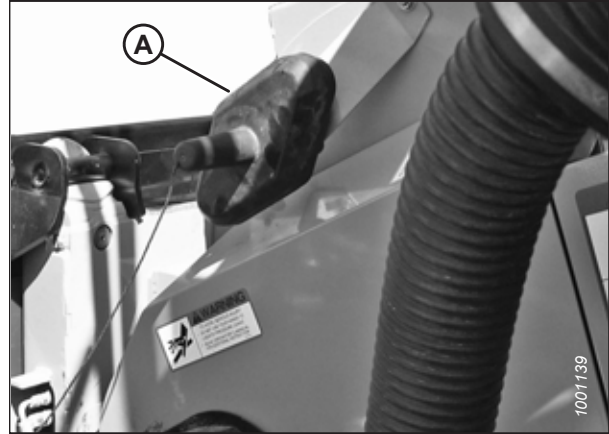

Figure 4.27: Receptacle Cover

- Pull driveline collar (A) back to release the driveline from the support bracket (B). Remove the driveline from the support bracket.

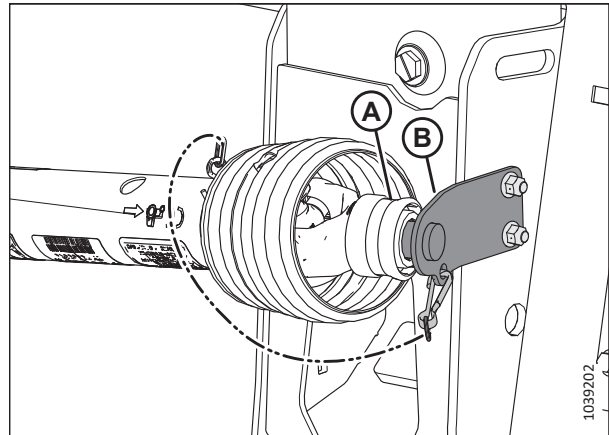

Figure 4.28: Driveline in Storage Position

- Attach driveline (A) to the combine output shaft.

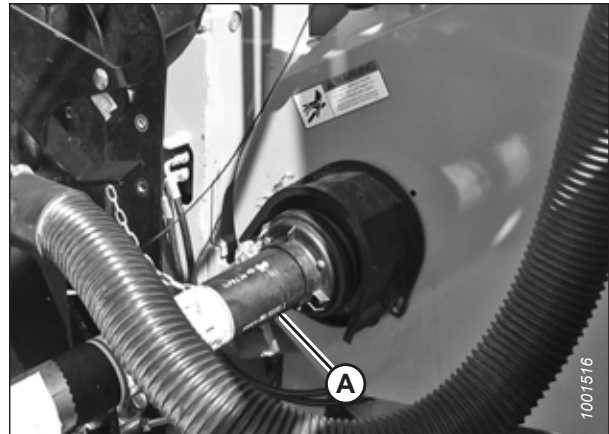

Figure 4.29: Driveline and Output Shaft

ATTACHING HEADER TO COMBINE

16. Proceed as follows:

- If the header is going to be used in the field now, disengage the float locks by pulling each float lock handle (A) away from the float module and into unlocked position (B).
- If the header is **NOT** going to be used in the field now, engage the float locks by pushing each float lock handle (A) toward the float module and into locked position (C).

NOTE:

The illustration shows the float lock handle on the right side of the header. The float lock handle on the left side of the header is the opposite.

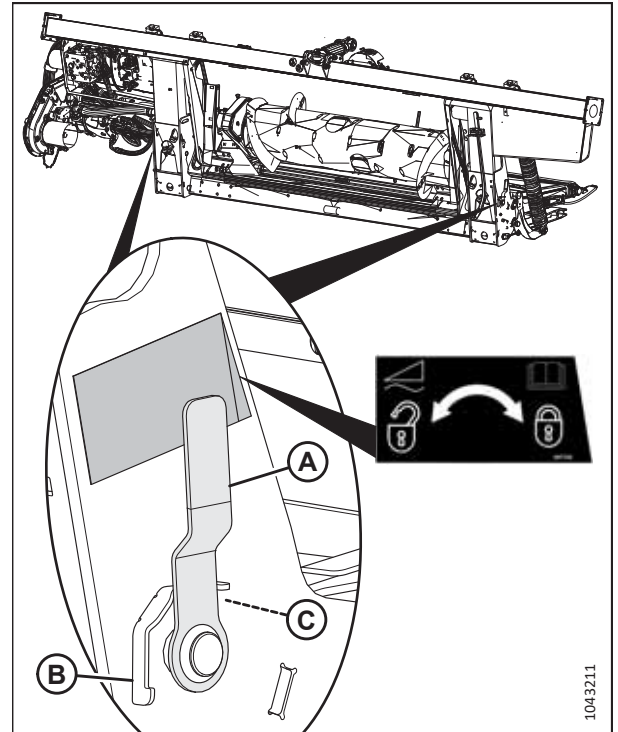

Figure 4.30: Float Lock Handle

4.3.1 Installing Limiter Link and Performing a Fore/Aft Tilt Calibration – CLAAS Lexion 5/6/7/8000 Series and TRION Series

To prevent interference between the float module and the feeder house dust blower shroud, a limiter link must be installed, calibrated, and configured on CLAAS Lexion 5/6/7/8000 series and TRION series combines before the combine is attached to the header for the first time.

DANGER

To prevent injury or death from the unexpected start-up or fall of a raised machine, always shut off the engine and remove the key from the ignition before leaving the operator's seat or making adjustments to the machine. If the feeder house is fully raised, always engage the safety props.

DANGER

Ensure that all bystanders have cleared the area.

IMPORTANT:

To prevent damage caused by interference between the header and feeder house dust blower shroud, make sure the combine is detached from the header before raising the feeder house or performing fore/aft tilt calibration.

1. Park the combine on a level surface.
2. Lower or raise the feeder house fully.

ATTACHING HEADER TO COMBINE

3. In CEBIS, navigate to HEADER (A), SETTINGS (B), HEADER PITCH (C). Adjust the faceplate pitch to 0.
4. Shut down the engine, and remove the key from the ignition.
5. If the feeder house is raised, engage the header safety props. For instructions, refer to the combine operator's manual.

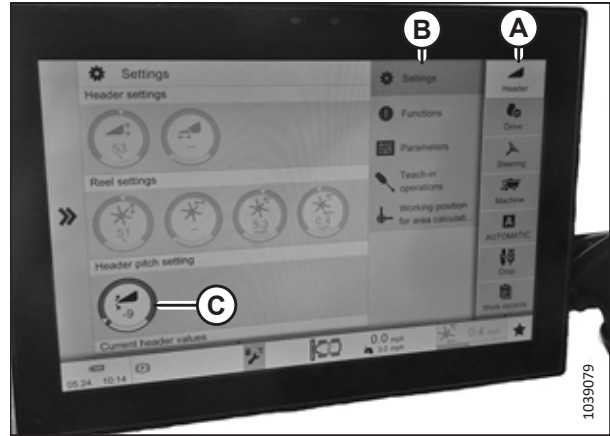

Figure 4.31: CEBIS Settings

6. Proceed as follows:
 - If installing limiter link (A) onto the feeder house, proceed to the next step.
 - If limiter link (A) is already installed on the feeder house, proceed to Step 14, page 69 for calibration instructions.

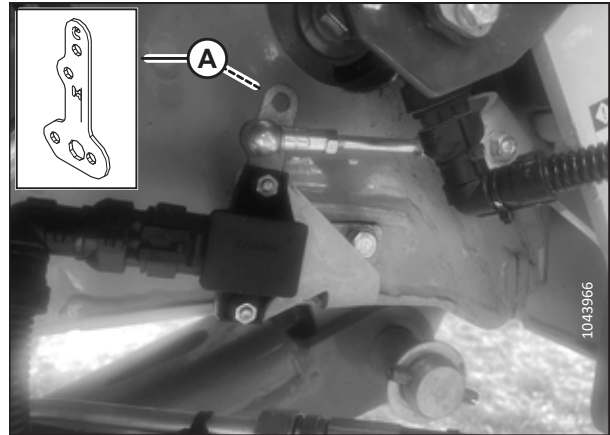

Figure 4.32: Limiter Link

7. Locate feeder house fore/aft tilt sensor (B) on the right side of the combine's feeder house, near header safety prop (A).

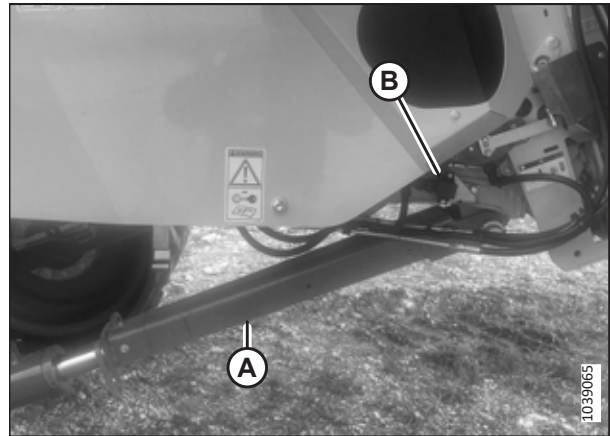

Figure 4.33: Sensor Limiter Link Location – Feeder House

ATTACHING HEADER TO COMBINE

8. Remove the nut that secures linkage (A) to the sensor arm.
9. Remove linkage (A) from the sensor arm.

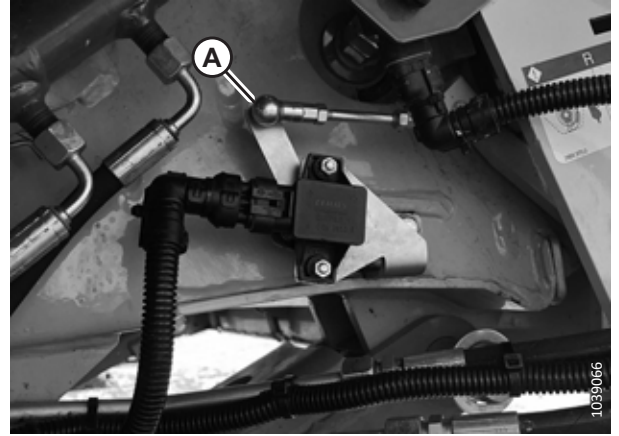

Figure 4.34: Sensor Arm Linkage

10. Remove two bolts (A) that secure sensor arm (B) to the sensor.

NOTE:

Do not unbolt the sensor from the combine.

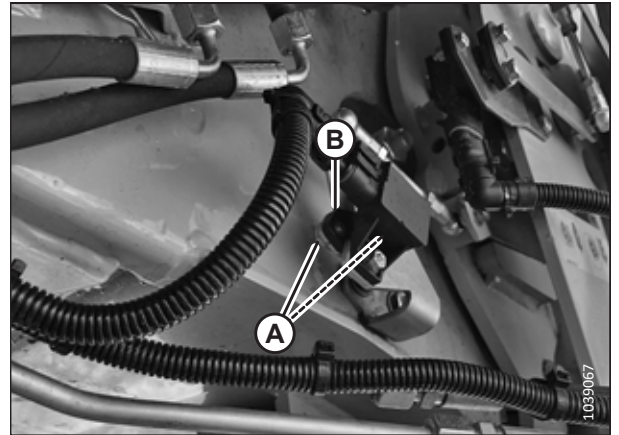

Figure 4.35: Sensor Arm

11. Install sensor arm (A) onto sensor (C). The bottom pointed end (B) of the sensor arm and the sensor pivot that the arm bolts to should both point towards the back of the combine. The extended part of the sensor arm should be pointing up.
12. Install the two bolts to secure sensor arm (A) to sensor (C).
13. Install linkage (D) into the upper hole "C" on the sensor arm.

IMPORTANT:

Make sure the sensor arm is installed in hole "C" before calibrating the system. Calibrating the system with the sensor arm installed in hole "M", instead of hole "C", will lead to mechanical interference once the header is connected to the combine.

14. If the header safety props are engaged, disengage them now. For instructions, refer to the combine operator's manual.
15. Start the engine.

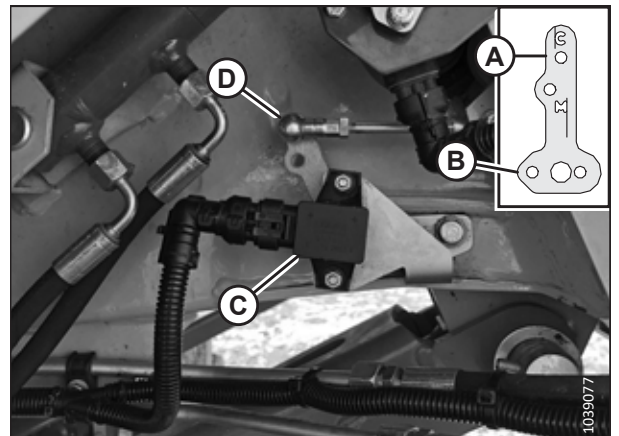

Figure 4.36: Sensor Arm Linkage

ATTACHING HEADER TO COMBINE

NOTE:

Step 17, [page 70](#) and Step 18, [page 70](#) describe performing a fore/aft tilt calibration.

16. In CEBIS, navigate to HEADER (A), TEACH IN OPERATIONS (B), and then HEADER PITCH (C).

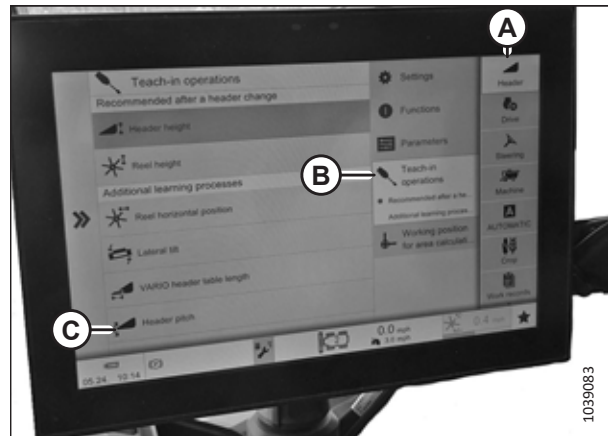

Figure 4.37: CEBIS Settings

17. Press arrow (A) to start the procedure. Follow the on-screen prompts.
18. Lower or raise the feeder house fully.
19. Shut down the engine, and remove the key from the ignition.
20. If the feeder house is raised, engage the header safety props.

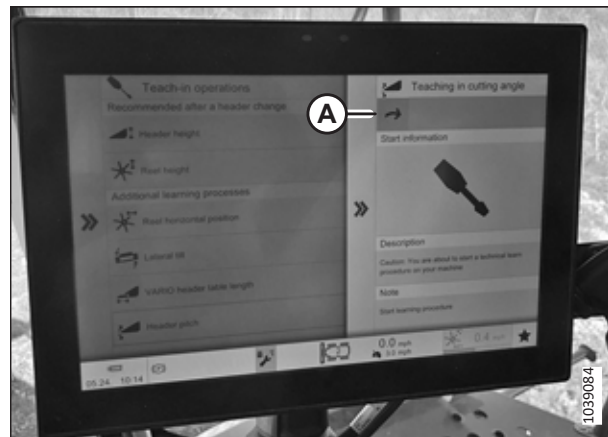

Figure 4.38: CEBIS Settings

21. Change the sensor linkage arm position from upper hole (A) labeled "C" to lower hole (B) labeled "M".
22. If the header safety props are engaged, disengage them now. For instructions, refer to the combine operator's manual.
23. Start the engine.
24. Connect the combine to the header. For instructions, refer to [4.3 Attaching Header to CLAAS Combine, page 62](#).

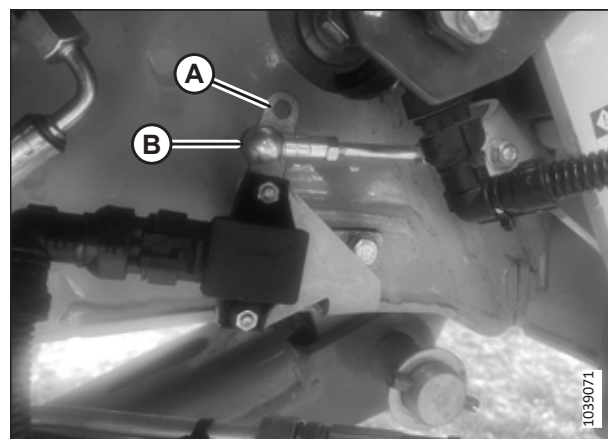

Figure 4.39: Sensor Arm Linkage

ATTACHING HEADER TO COMBINE

25. Slowly tilt the combine faceplate back to ensure that there is **NO** interference between the header and step (A) on the combine feeder house.
26. Tilt the faceplate forward until "0" is shown on the display.

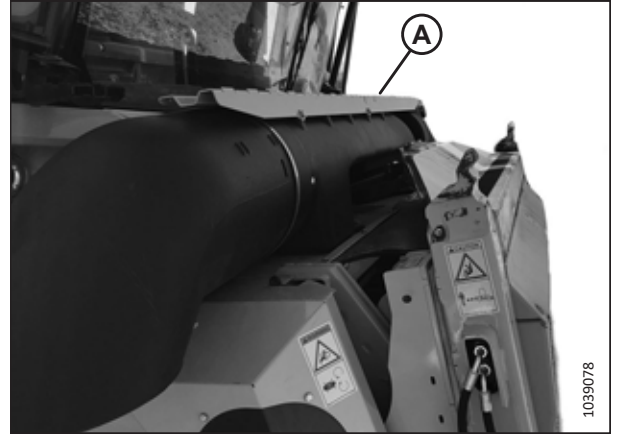

Figure 4.40: Step Contact

4.4 Attaching Header to IDEAL™ Series Combine

The header will need to be physically connected to the combine's feeder house, and the electrical and hydraulic connections completed.

DANGER

To prevent injury or death from the unexpected start-up of the machine, always stop the engine and remove the key from the ignition before leaving the operator's seat for any reason.

DANGER

Ensure that all bystanders have cleared the area.

IMPORTANT:

If the combine is **NOT** equipped with a rock trap, feeder house faceplate (A) **MUST** be in mid-position (B). For instructions on adjusting the faceplate, refer to the combine operator's manual.

NOTE:

A rock trap prevents rocks or debris from entering the combine, and is located on the front of the combine and behind the feeder house.

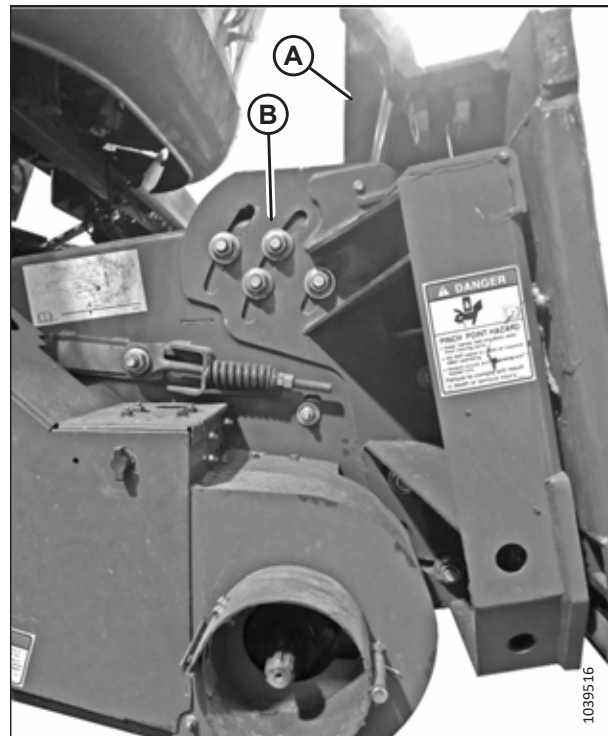

Figure 4.41: Faceplate Tilted to Mid-Position on Unspecified Combine

1. Shut down the engine, and remove the key from the ignition.

ATTACHING HEADER TO COMBINE

2. Pull lever (A) up to retract pins (B) at the bottom left and right sides of the feeder house.

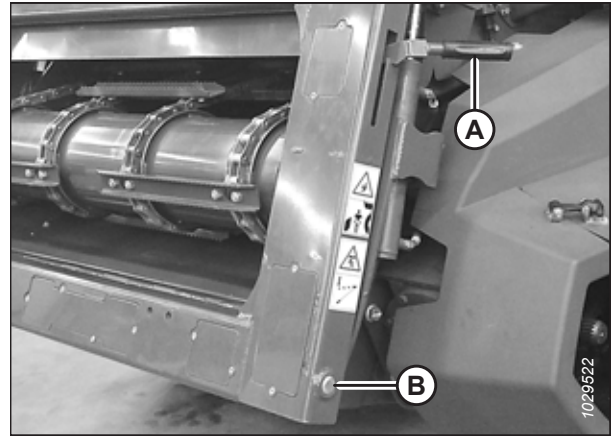

Figure 4.42: Feeder House

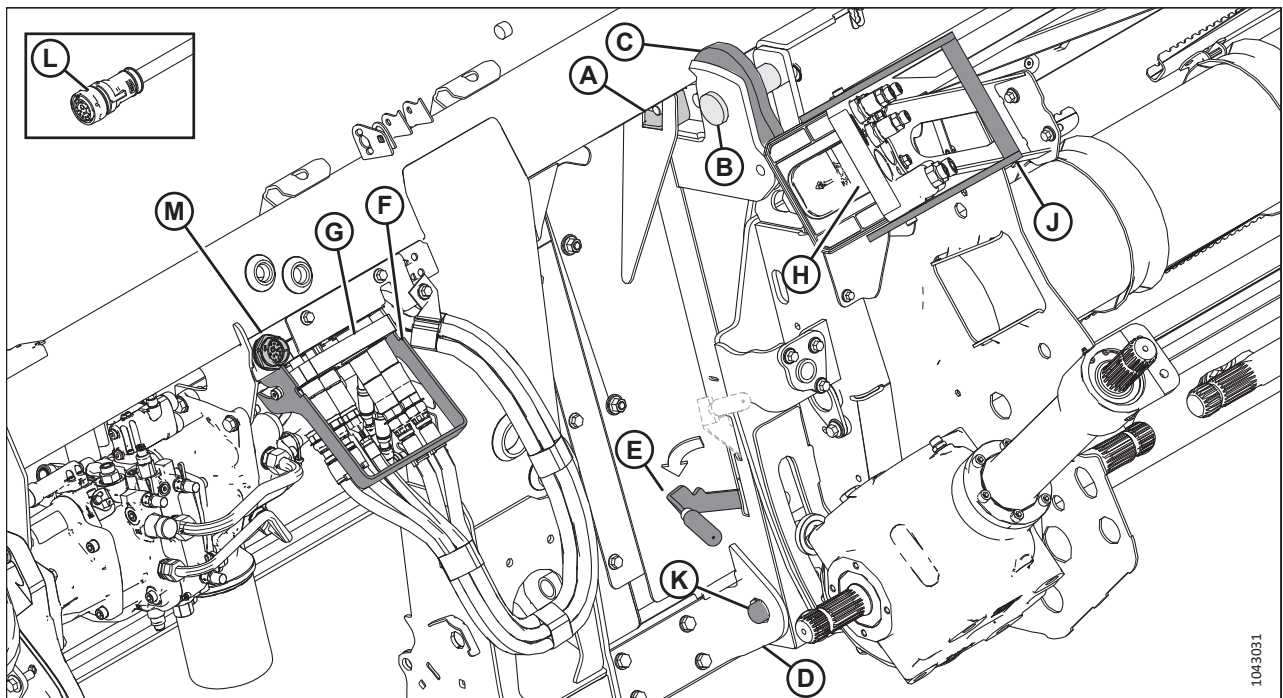

Figure 4.43: Float Module with Dynamatic Pump

3. Drive the combine slowly up to the header until the feeder house is directly under top beam (A), and pins (B) are under hooks (C) on the transition frame.
4. Raise the feeder house until transition frame top beam (A) is fully resting on the feeder house. Raise the header slightly off the ground.

IMPORTANT:

The full weight of the header must be on the feeder house, **NOT** on pins (B).

5. Position the bottom of the feeder house so that locking pins (K) align with the holes in mount (D).
6. Shut down the engine, and remove the key from the ignition.
7. Push lever (E) down to extend locking pins (K) into mount (D).
8. Lower handle (F) to release multicoupler (G) from the header.

ATTACHING HEADER TO COMBINE

9. Open the cover on combine receptacle (H).
10. Push handle (J) to the fully open position.
11. Clean the mating surfaces of the coupler and receptacle.
12. Position coupler (G) onto combine receptacle (H), and pull handle (J) to fully insert the multicoupler into the receptacle.
13. Remove cab control kit connector C81A (L) from the storage location on the combine and connect it to C81B (M) on the float module. Turn the collar on the connector to lock it in place.
14. Pull driveline collar (A) back to release the driveline from the support bracket. Remove the driveline from the support bracket.

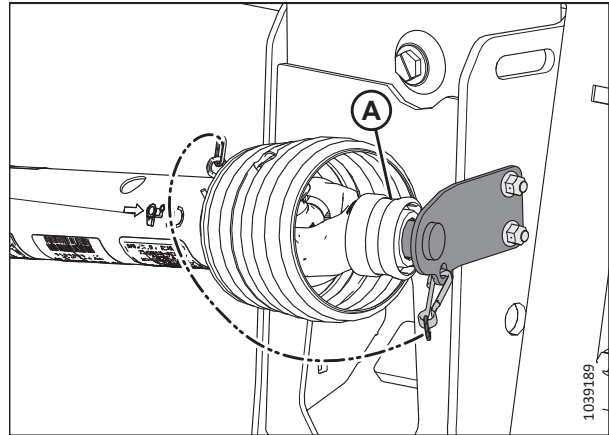

Figure 4.44: Driveline in Storage Position

15. Pull back collar (A) on the end of driveline and push it onto combine output shaft (B) until the collar locks.

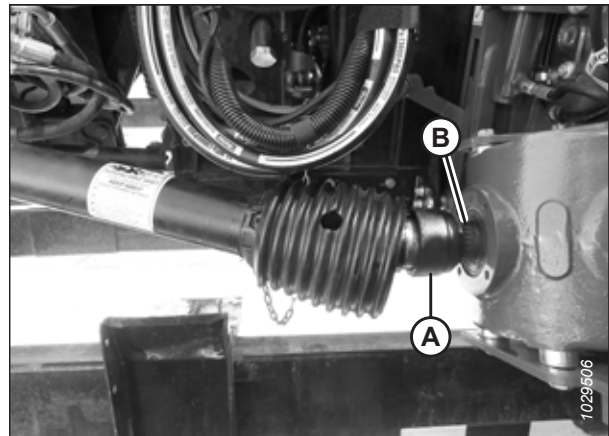

Figure 4.45: Connecting Driveline to Combine

ATTACHING HEADER TO COMBINE

16. Proceed as follows:

- If the header is going to be used in the field now, disengage the float locks by pulling each float lock handle (A) away from the float module and into unlocked position (B).
- If the header is **NOT** going to be used in the field now, engage the float locks by pushing each float lock handle (A) toward the float module and into locked position (C).

NOTE:

The illustration shows the float lock handle on the right side of the header. The float lock handle on the left side of the header is the opposite.

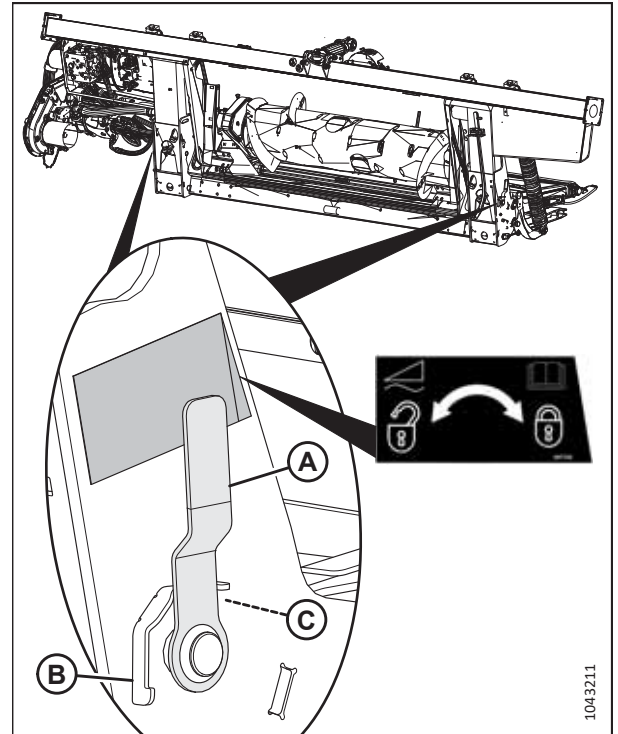

Figure 4.46: Float Lock Handle

4.5 Attaching Header to John Deere Combine

The header will need to be physically connected to the combine's feeder house, and the electrical and hydraulic connections completed.

DANGER

To prevent injury or death from the unexpected start-up of the machine, always stop the engine and remove the key from the ignition before leaving the operator's seat for any reason.

DANGER

Ensure that all bystanders have cleared the area.

IMPORTANT:

If the combine is **NOT** equipped with a rock trap, feeder house faceplate (A) **MUST** be in mid-position (B). For instructions on adjusting the faceplate, refer to the combine operator's manual.

NOTE:

A rock trap prevents rocks or debris from entering the combine, and is located on the front of the combine and behind the feeder house.

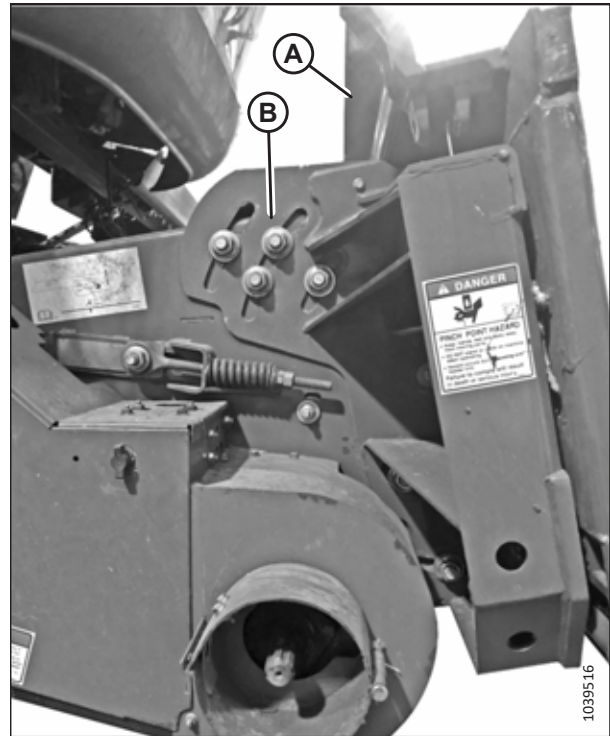

Figure 4.47: Faceplate Tilted to Mid-Position on Unspecified Combine

1. Shut down the engine, and remove the key from the ignition.

ATTACHING HEADER TO COMBINE

2. Push handle (A) on the combine multicoupler receptacle toward the feeder house to retract pins (B) at the bottom corners of the feeder house. Clean the receptacle.
3. Slowly drive the combine up to the header until feeder house saddle (C) is directly under float module top cross member (D).
4. Raise the feeder house slightly to lift the header, ensuring that the feeder house saddle is properly engaged in the float module frame.
5. Shut down the engine, and remove the key from the ignition.

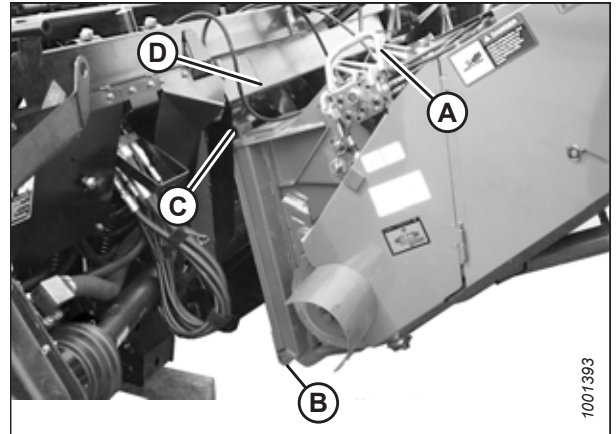

Figure 4.48: Combine and Float Module

6. Pull handle (A) on the float module to release multicoupler (B) from the storage position.
7. Remove the multicoupler, and push the handle back into the float module.

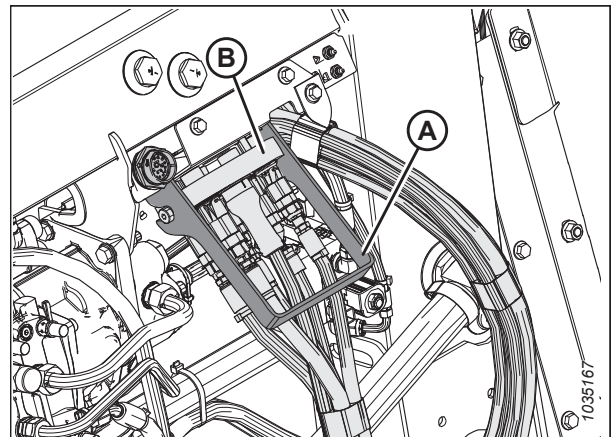

Figure 4.49: Multicoupler Storage

8. Position multicoupler (A) onto the receptacle.
9. Pull locking pin (B) and lower handle (C) until locking pin (B) is fully engaged.

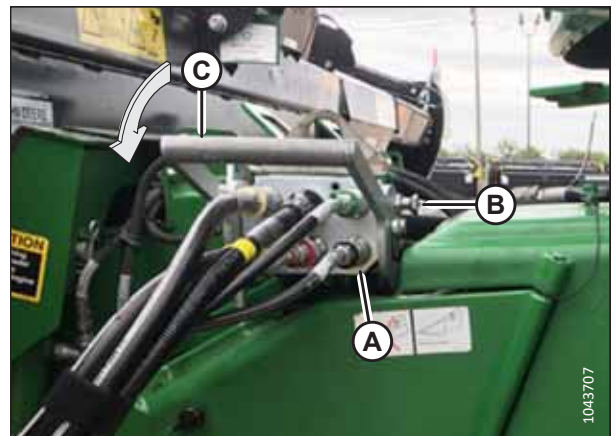

Figure 4.50: Multicoupler

ATTACHING HEADER TO COMBINE

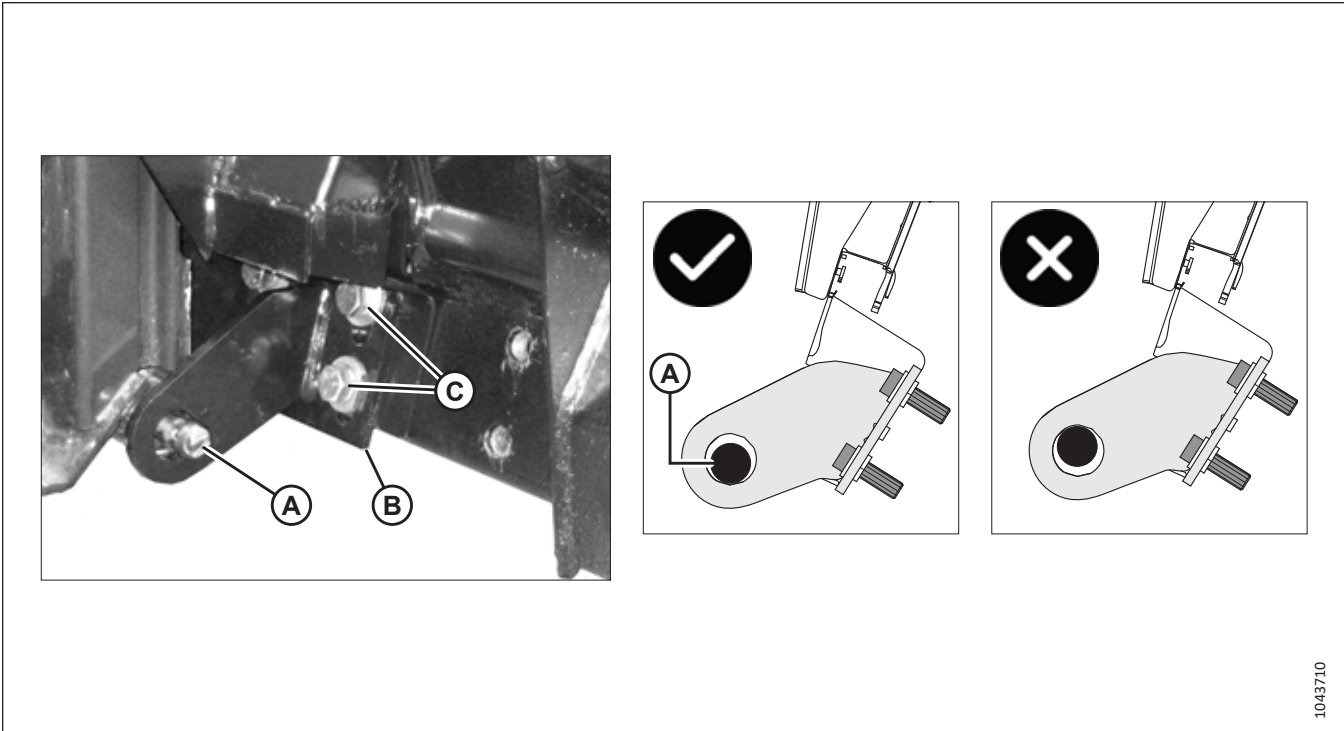

Figure 4.51: Feeder House Locking Pin used on John Deere 60, 70, S, or T Series

10. **60, 70, S, or T Series:** Ensure that both feeder house locking pins (A) are fully engaged into the float module anchor brackets (B), and sit toward the bottom of the circular cutouts of the brackets, with some clearance as shown.

IMPORTANT:

The header might fall off the feeder house if pins (A) do not fully engage the anchor brackets. If pins (A) do not fully engage the brackets, first ensure that the multicoupler locking pin is fully engaged. If the problem persists, refer to the original equipment manufacturer (OEM) manual for instructions on how to adjust the feeder house locking pins outward.

IMPORTANT:

The pin should sit at the bottom of the circular cutout so that there is little to no ability for the frame to lift off the feeder house. To adjust an anchor bracket, loosen bolts (C), re-position the bracket as required, and re-tighten bolts (C) to 75 Nm (55 lbf·ft).

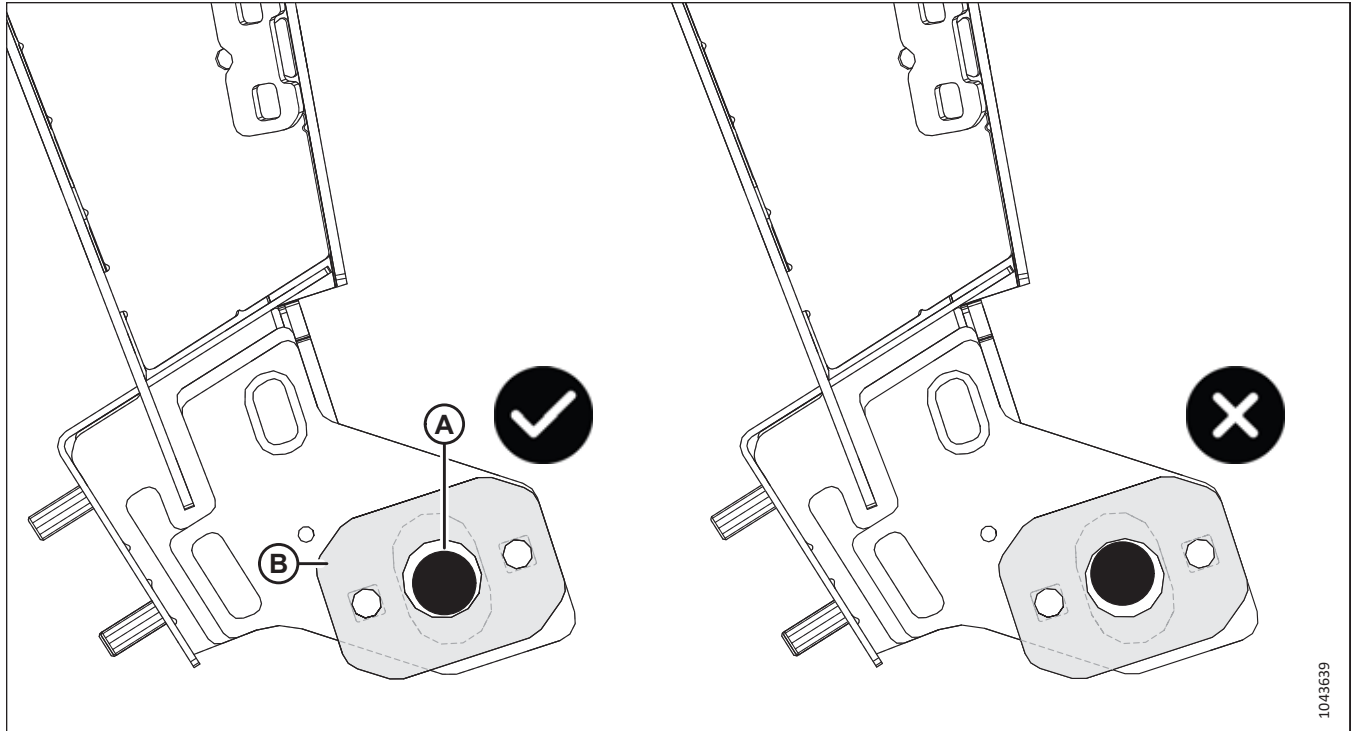

Figure 4.52: John Deere X9 Feeder House Locking Pin Alignment – Single-Position Adjustment Plate

11. **X9 Series:** Ensure that both feeder house locking pins (A) are fully engaged into the float module anchor brackets, and sit toward the bottom of the circular cutout in adjustment plates (B) with some clearance as shown.

IMPORTANT:

The header might fall off the feeder house if pins (A) do not fully engage the anchor brackets. If pins (A) do not fully engage the brackets, first ensure that the multicoupler locking pin is fully engaged. If the problem persists, refer to the original equipment manufacturer (OEM) manual for instructions on how to adjust the feeder house locking pins outward.

IMPORTANT:

The pin should sit at the bottom of the circular cutout so that there is little to no ability for the frame to lift off the feeder house. Single-position adjustment plates (with only one set of mounting holes) are shown in Figure 4.52, page 79. If the ideal locking pin alignment cannot be achieved using the single-position plates, then position two-position adjustment plates (with two sets of mounting holes), according to Figure 4.53, page 80 or Figure 4.54, page 80. All adjustment plates and their mounting nuts **MUST** be on the outboard side of the transition frame anchor plates.

ATTACHING HEADER TO COMBINE

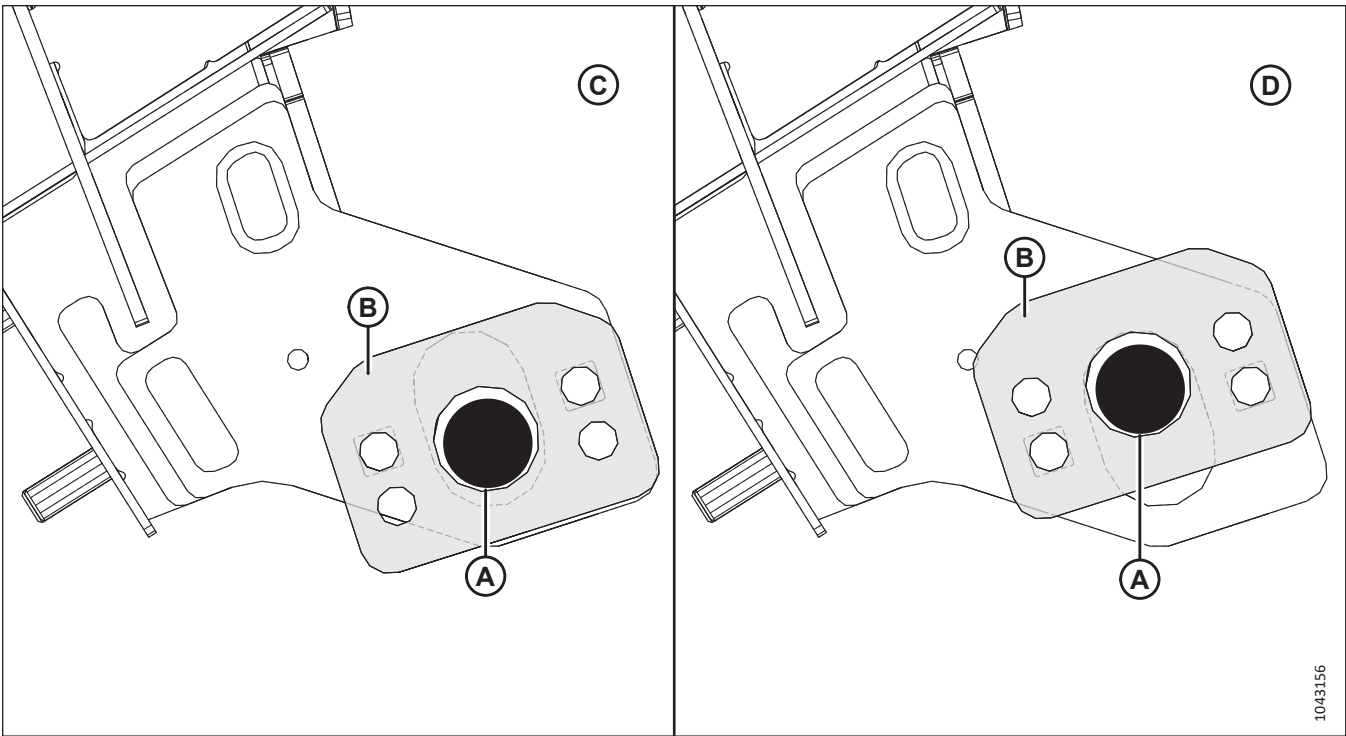

Figure 4.53: X9 Series Two-Position Adjustment Plate, Side A

A – Combine Locking Pin

B – Two-Position Locking Plate

C – Position 1

D – Position 2

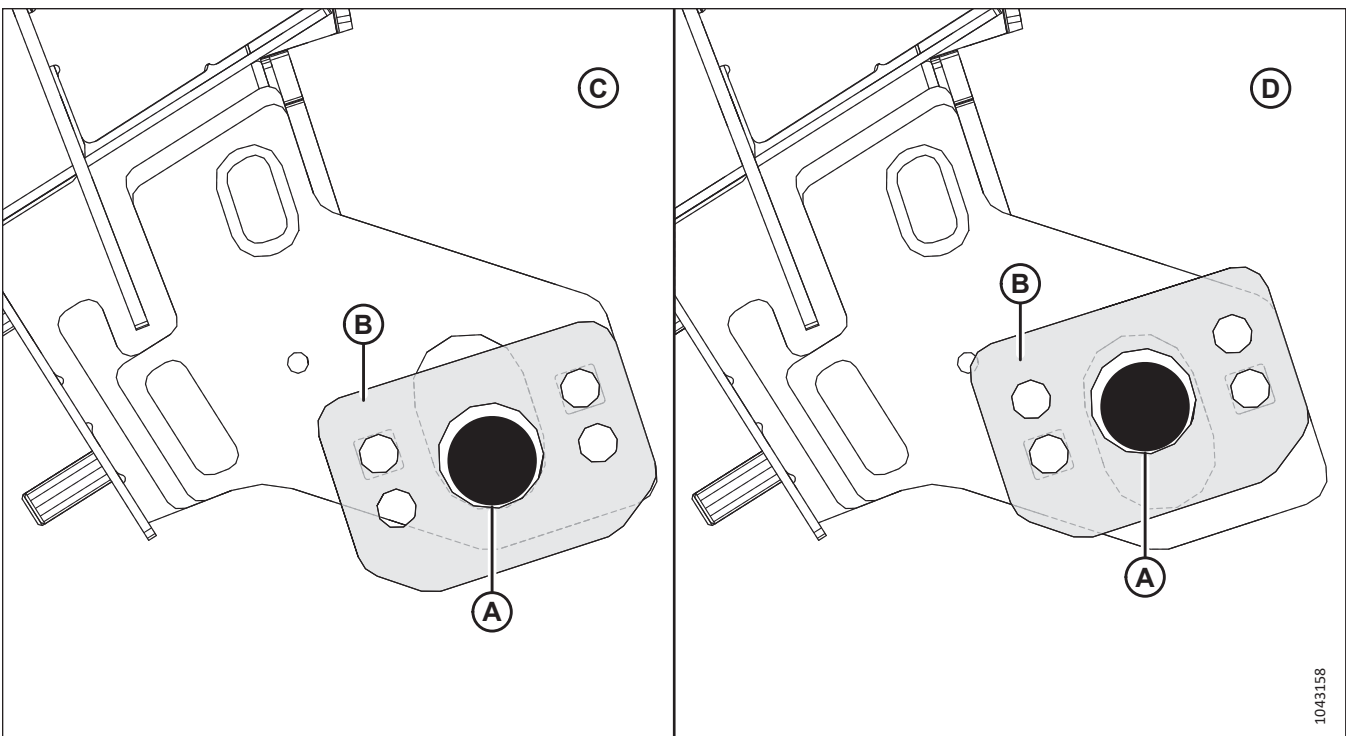

Figure 4.54: X9 Series Two-Position Adjustment Plate, Side B

A – Combine Locking Pin

B – Two-Position Locking Plate

C – Position 1

D – Position 2

ATTACHING HEADER TO COMBINE

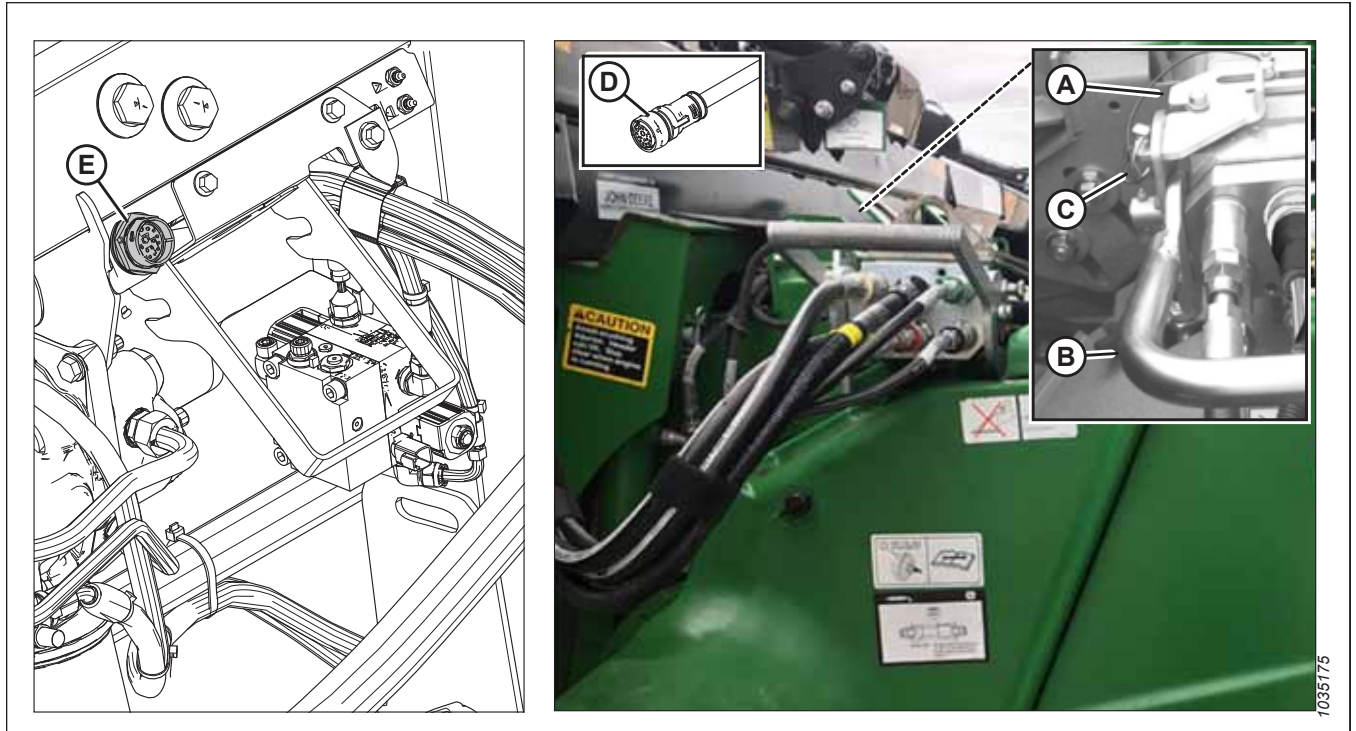

Figure 4.55: Multicoupler Lock, Electrical Connections

12. Slide latch (A) to lock handle (B) in position and secure it with lynch pin (C).
13. **60, 70, S, or T Series:** Remove cab control kit connector C81A (D) from its storage location on the combine and connect it to receptacle C81B (E) on the float module. Turn the collar on the connector to lock it in place.

ATTACHING HEADER TO COMBINE

14. Pull driveline collar (A) back to release the driveline from support bracket (B). Remove the driveline from the support bracket.

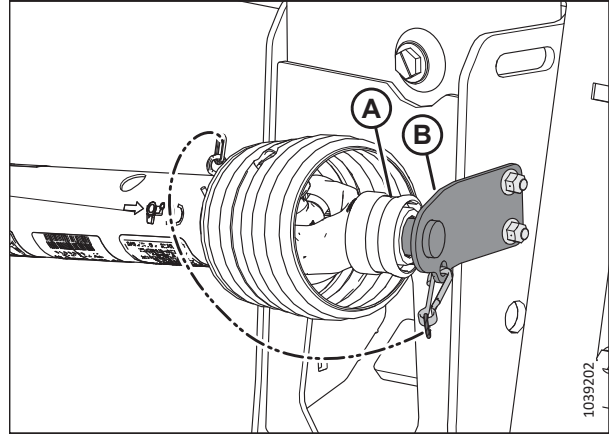

Figure 4.56: Driveline in Storage Position – Driveline B7038 or B7039

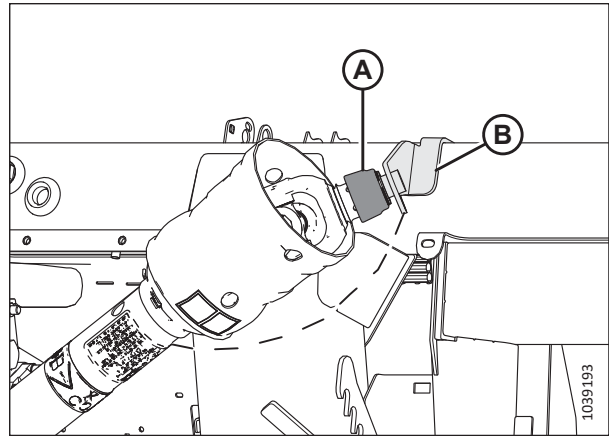

Figure 4.57: Driveline in Storage Position – Sidehill/Hillside Driveline B7326 or B7182

15. Pull back collar (A) on the end of the driveline, and push the driveline onto combine output shaft (B) until the collar locks.

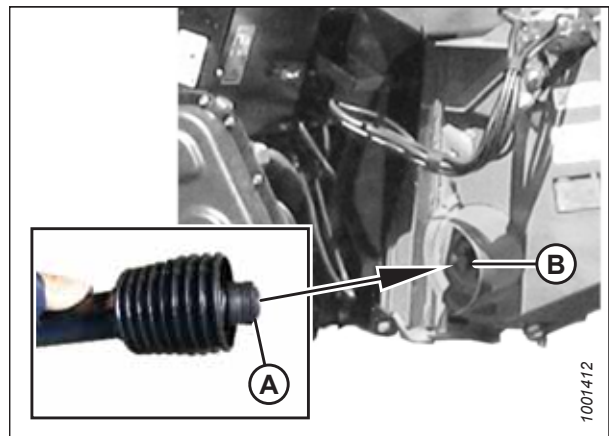

Figure 4.58: Driveline

ATTACHING HEADER TO COMBINE

16. Disengage the float locks by pulling each float lock handle (A) away from the float module, and setting it in unlocked position (B).

NOTE:

The illustration shows the float lock handle on the right side of the header; the float lock handle on the left side of the header is the opposite.

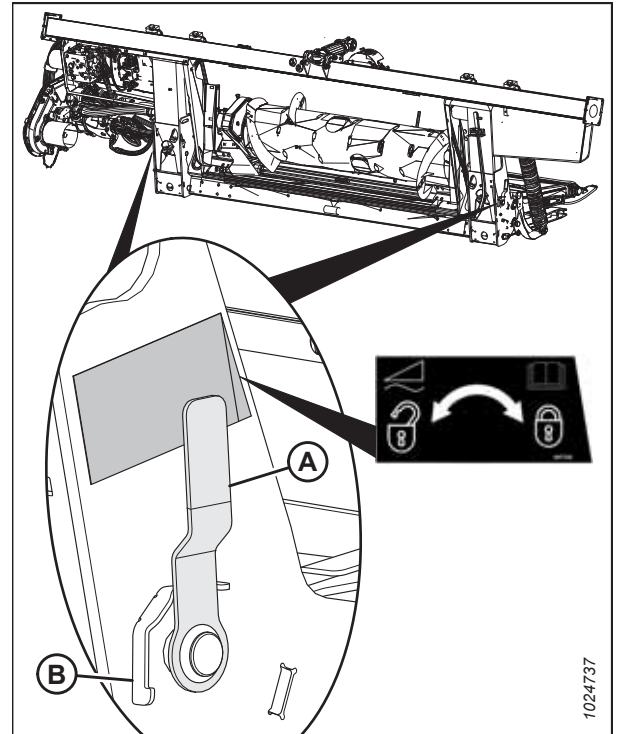

Figure 4.59: Float Lock Handle

4.6 Attaching Header to New Holland CR, CX, or CH Combine

The header will need to be physically connected to the combine's feeder house, and the electrical and hydraulic connections completed.

DANGER

To prevent injury or death from the unexpected start-up of the machine, always stop the engine and remove the key from the ignition before leaving the operator's seat for any reason.

DANGER

Ensure that all bystanders have cleared the area.

IMPORTANT:

If the combine is **NOT** equipped with a rock trap, feeder house faceplate (A) **MUST** be in mid-position (B). For instructions on adjusting the faceplate, refer to the combine operator's manual.

NOTE:

A rock trap prevents rocks or debris from entering the combine, and is located on the front of the combine and behind the feeder house.

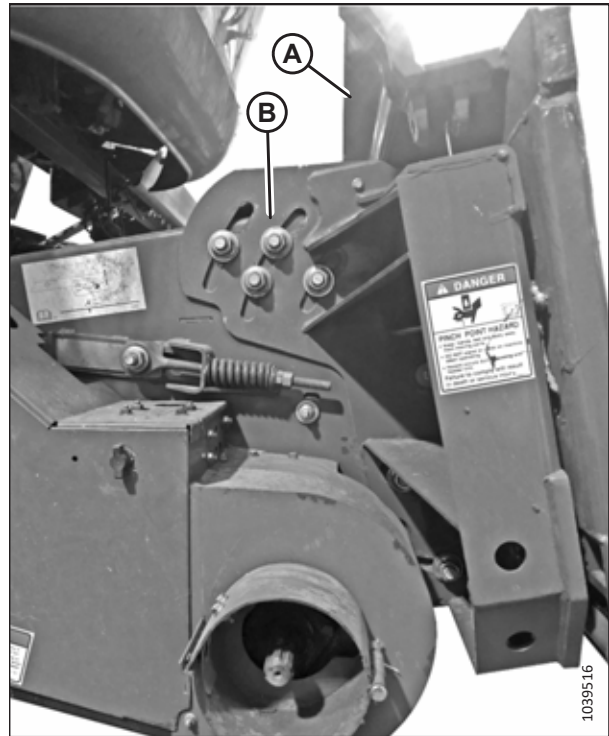

Figure 4.60: Faceplate Tilted to Mid-Position on Unspecified Combine

1. Shut down the engine, and remove the key from the ignition.

ATTACHING HEADER TO COMBINE

2. Ensure that handle (A) is positioned so that locks (B) can engage the float module.

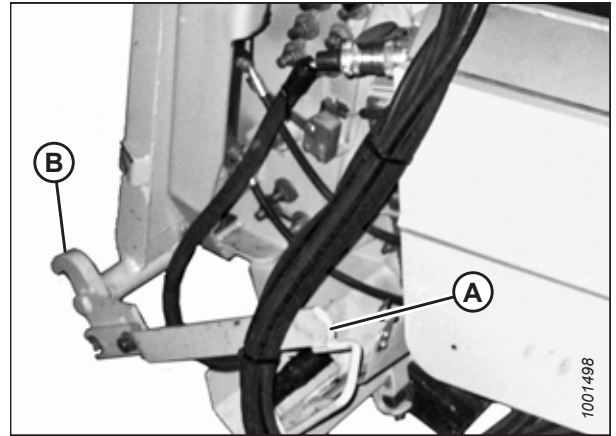

Figure 4.61: Feeder House Locks

3. Slowly drive the combine up to the float module until feeder house saddle (A) is directly under float module top cross member (B).
4. Raise the feeder house slightly to lift the header. Ensure that the feeder saddle is fully engaged in the float module frame.
5. Shut down the engine, and remove the key from the ignition.

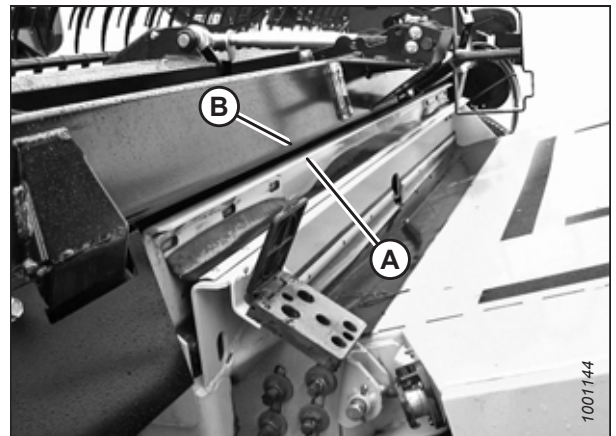

Figure 4.62: Header on Combine

6. On the left side of the feeder house, lift lever (A) on the float module, and push handle (B) on the combine to engage locks (C) on both sides of the feeder house.
7. Push down on lever (A) so the slot in the lever engages the handle and locks it in place.
8. If the lock does not fully engage pin (D) on the float module when lever (A) and handle (B) are engaged, loosen bolts (E) and adjust lock (C). Retighten the bolts.

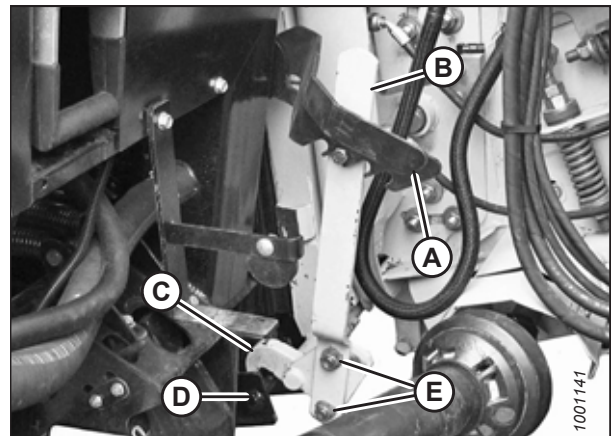

Figure 4.63: Feeder House Locks

ATTACHING HEADER TO COMBINE

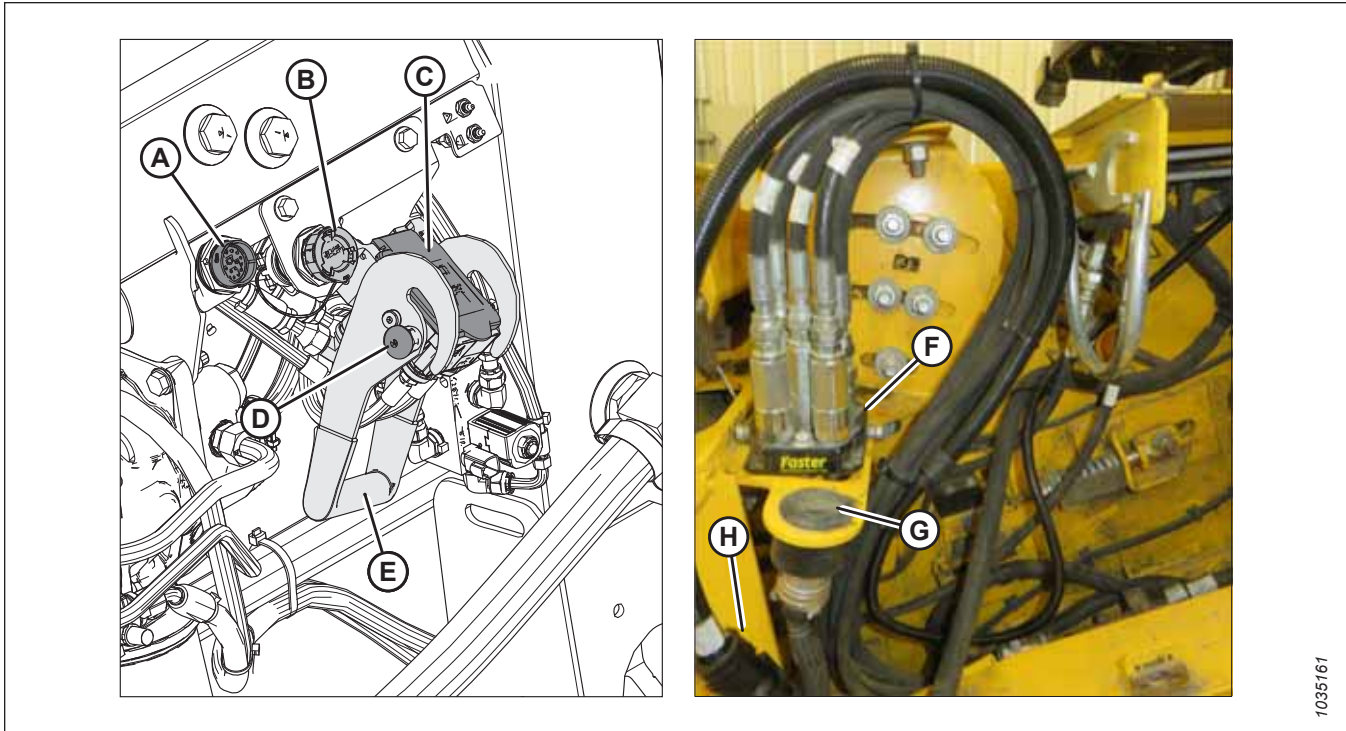

Figure 4.64: Multicoupler and Electrical Connections

9. **If MacDon in-cab controls are installed:** Remove the cap from connector C81B (A).
10. Remove the cap from connector C72B (B).
11. Remove the cover from hydraulic receptacle (C). Clean the receptacle mating surfaces.
12. Push in lock button (D) and pull handle (E) to the fully open position.
13. Remove hydraulic quick coupler (F) from the storage plate on the combine. Clean the mating surface of the coupler.
14. Position coupler (F) onto float module receptacle (C).
15. Push handle (E) to the closed position until lock button (D) snaps out.
16. Remove combine connector (G) from its storage location on the combine and connect it to receptacle C72B (B). Turn the collar on the connector to lock it in place.
17. **If MacDon in-cab controls are installed:** Remove cab control kit connector C81A (H) from its storage location on the combine and connect it to receptacle C81B (A). Turn the collar on the connector to lock it in place.

ATTACHING HEADER TO COMBINE

18. Pull driveline collar (A) back to release the driveline from the support bracket (B). Remove the driveline from the support bracket.

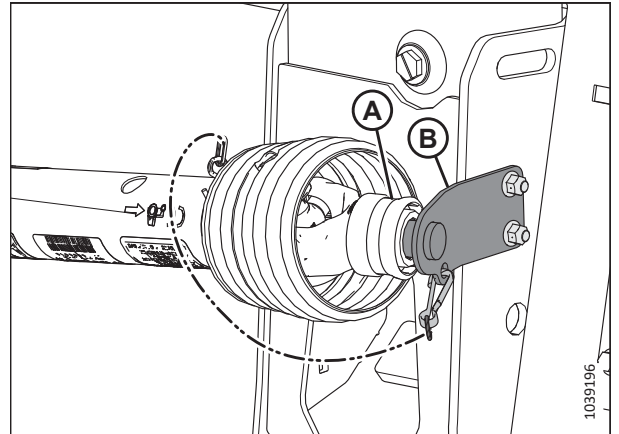

Figure 4.65: Driveline in Storage Position – Driveline B7038 or B7039

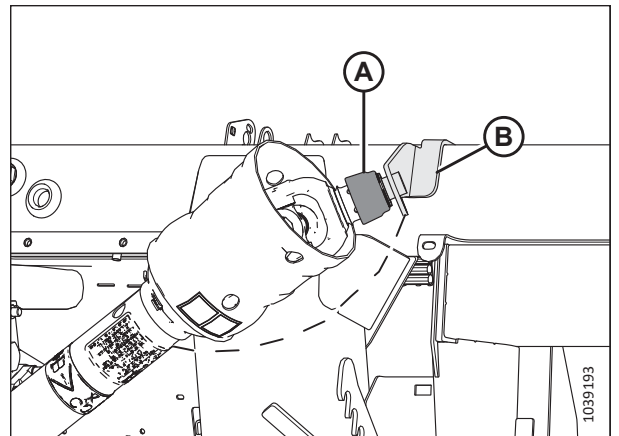

Figure 4.66: Driveline in Storage Position – Sidehill/Hillside Driveline B7180, B7181, or B7326

19. Pull back the collar on the end of the driveline, and push the driveline onto combine output shaft (A) until the collar locks.

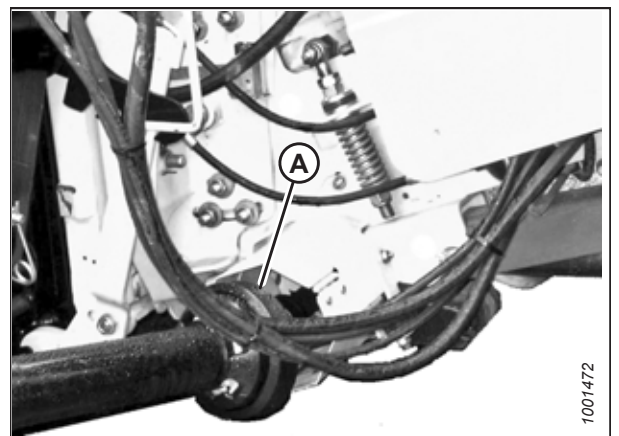

Figure 4.67: Driveline and Output Shaft

ATTACHING HEADER TO COMBINE

20. Proceed as follows:

- If the header is going to be used in the field now, disengage the float locks by pulling each float lock handle (A) away from the float module and into unlocked position (B).
- If the header is **NOT** going to be used in the field now, engage the float locks by pushing each float lock handle (A) toward the float module and into locked position (C).

NOTE:

The illustration shows the float lock handle on the right side of the header. The float lock handle on the left side of the header is the opposite.

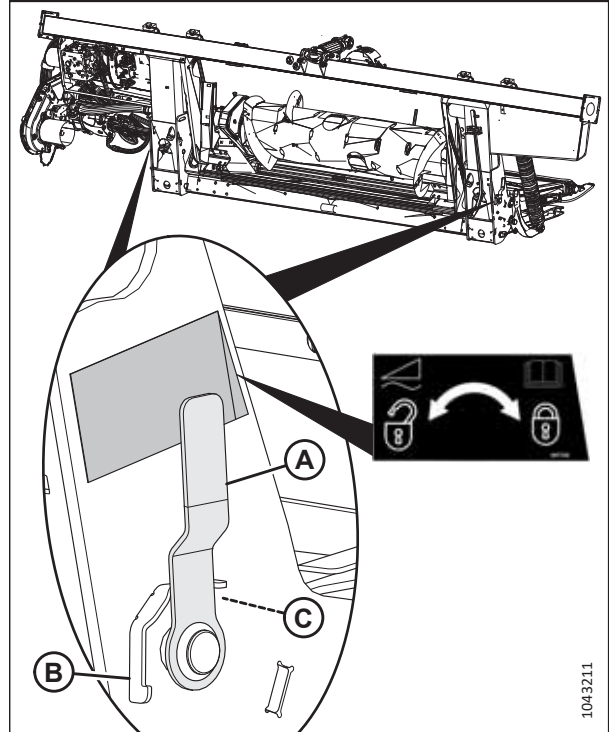

Figure 4.68: Float Lock Handle

4.7 Attaching Header to Rostselmash Combine

The header will need to be physically connected to the combine's feeder house, and the electrical and hydraulic connections completed.

DANGER

To prevent injury or death from the unexpected start-up of the machine, always stop the engine and remove the key from the ignition before leaving the operator's seat for any reason.

DANGER

Ensure that all bystanders have cleared the area.

IMPORTANT:

If the combine is **NOT** equipped with a rock trap, feeder house faceplate (A) **MUST** be in mid-position (B). For instructions on adjusting the faceplate, refer to the combine operator's manual.

NOTE:

A rock trap prevents rocks or debris from entering the combine, and is located on the front of the combine and behind the feeder house.

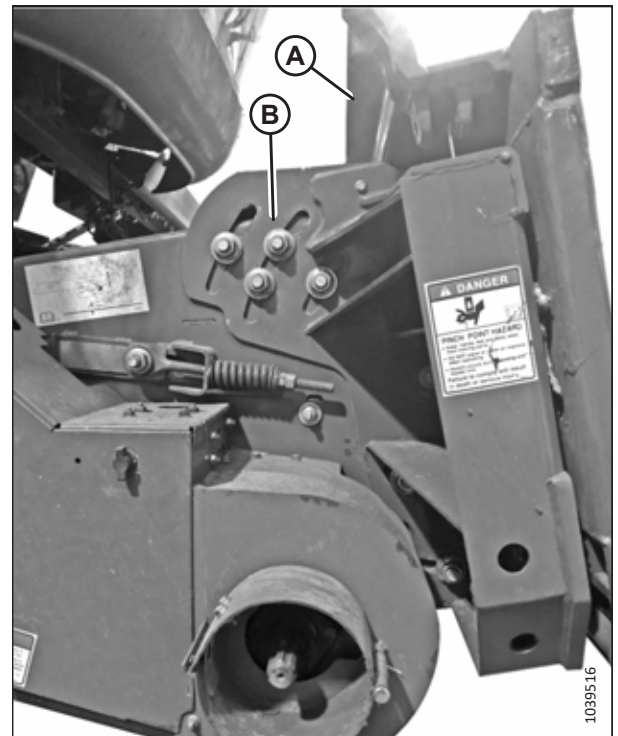

Figure 4.69: Faceplate Tilted to Mid-Position on Unspecified Combine

1. Slowly drive the combine up to the header until feeder house saddle (A) is directly under float module top cross member (B).
2. Raise the feeder house slightly to lift the header, ensuring the feeder house saddle is properly engaged in the float module frame.
3. Shut down the engine, and remove the key from the ignition.

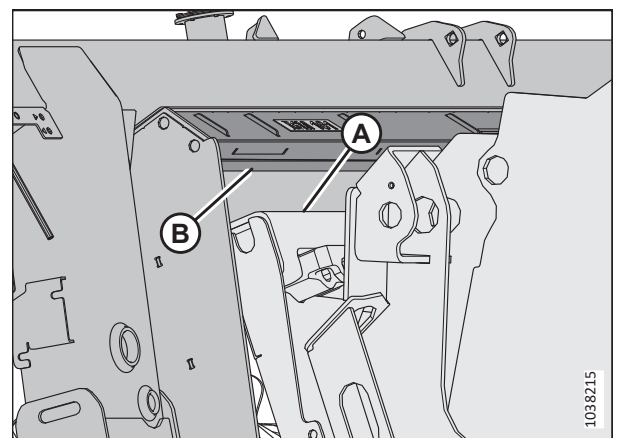

Figure 4.70: Combine and Float Module

ATTACHING HEADER TO COMBINE

4. Pull pin (A) outward and rotate handle (B) until both feeder house pins (C) are fully engaged into float module brackets (D).

NOTE:

If pins (C) do not fully engage the float module brackets, loosen bolts (E) and adjust brackets (D) as required.

5. Tighten nuts (E).

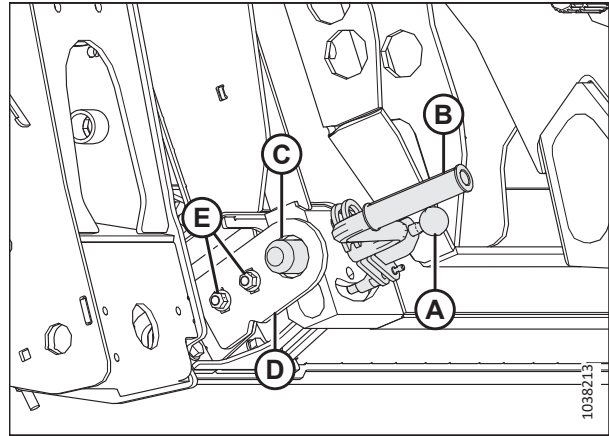

Figure 4.71: Feeder House Pin

6. Push in lock button (A) and pull handle (B) to the fully open position.
7. Remove the hydraulic quick coupler from the storage plate on the combine. Clean the mating surface of the coupler.
8. Position the combine coupler onto the float module receptacle. Push down on the handle to engage the pins into the receptacle.
9. Push the handle down to the closed position until lock button (B) snaps out.
10. Remove the combine connector from the storage location on the combine and connect it to receptacle (C). Turn the collar on the connector to lock it in place.
11. Remove the cab control kit connector C81A from the storage location on the combine and connect it to connector C81B (D). Turn the collar on the connector to lock it.

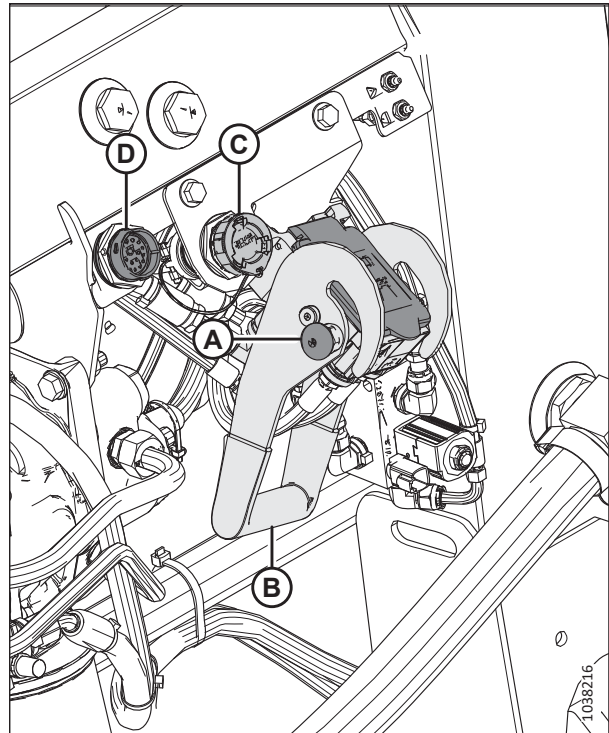

Figure 4.72: Multicoupler Storage

ATTACHING HEADER TO COMBINE

12. Detach safety chain (C) from support bracket (B).
13. Pull driveline collar (A) back to release the driveline from the support bracket. Remove the driveline from the support bracket.

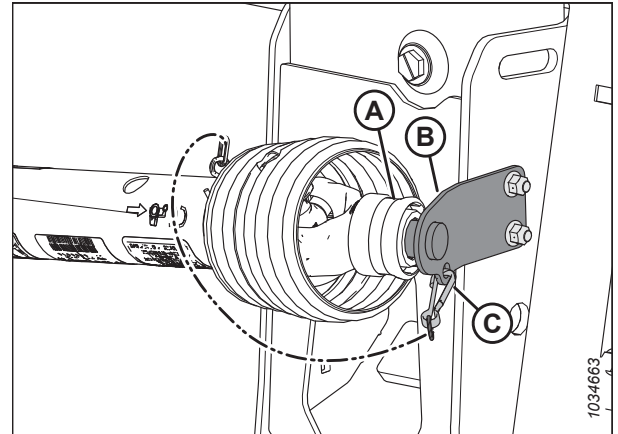

Figure 4.73: Driveline in Storage Position

14. Pull back collar (A) on the end of the driveline, and push the driveline onto combine output shaft (B) until the collar locks.

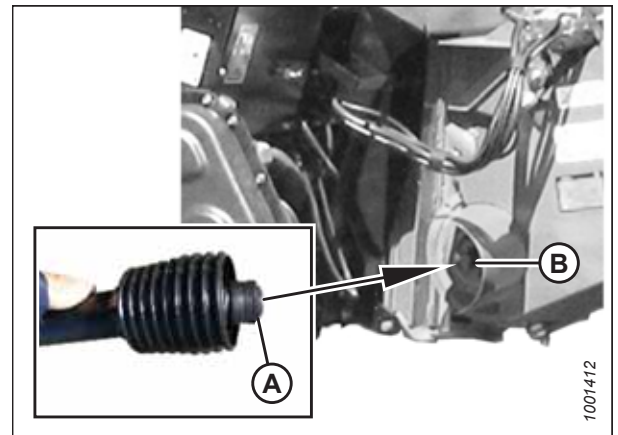

Figure 4.74: Driveline

ATTACHING HEADER TO COMBINE

15. Proceed as follows:

- If the header is going to be used in the field now, disengage the float locks by pulling each float lock handle (A) away from the float module and into unlocked position (B).
- If the header is **NOT** going to be used in the field now, engage the float locks by pushing each float lock handle (A) toward the float module and into locked position (C).

NOTE:

The illustration shows the float lock handle on the right side of the header. The float lock handle on the left side of the header is the opposite.

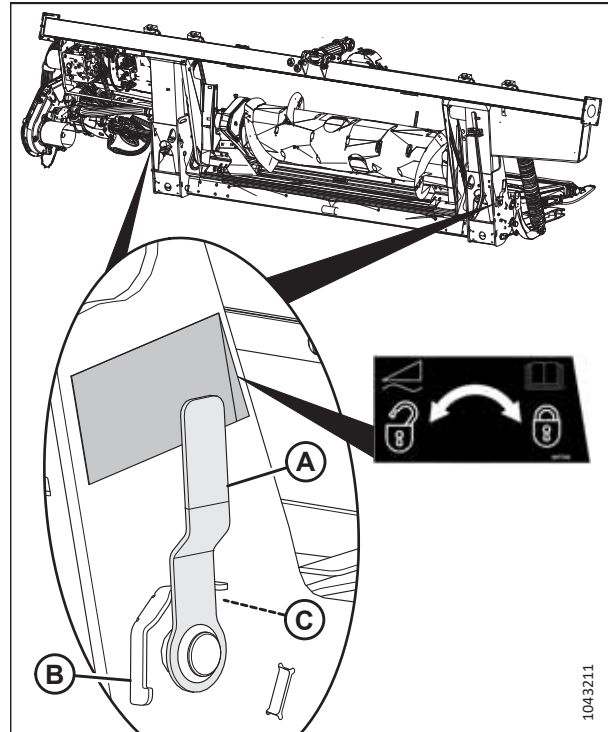

Figure 4.75: Float Lock Handle

Chapter 5: Completing Header Assembly

The header will need further assembly before it can be run up and tested.

5.1 Installing Center-Link Cylinder (Parts Bag MD #347601)

The center-link cylinder hydraulically adjusts the tilt angle of the header. It will need to be installed on the header.

1. Retrieve the center-link part bag (MD #347601). For a list of parts, refer to Table 5.1, page 93.

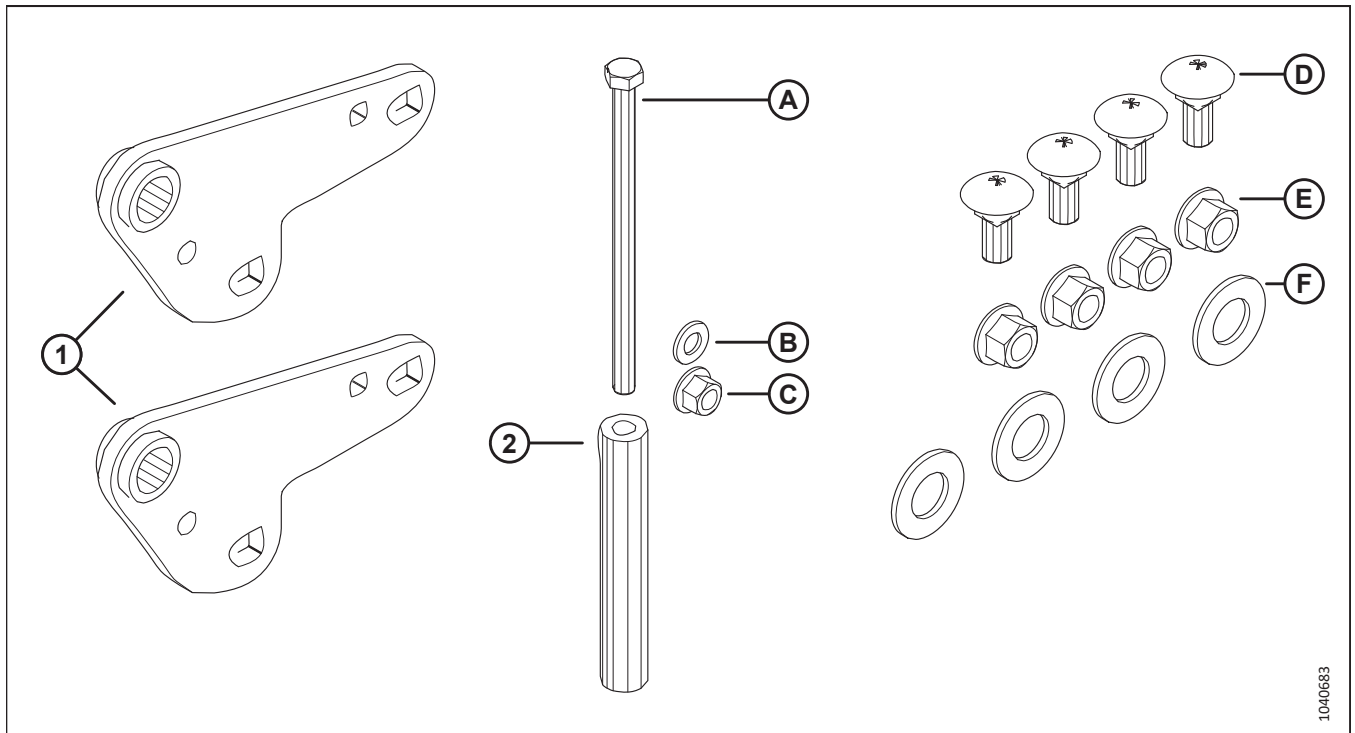

Figure 5.1: Center-Link Part Bag (MD #347601)

Table 5.1 Center-Link Part Bag (MD #347601)

Ref	Part Number	Description	Quantity
1	314645	WELDMENT – TOP LINK ANCHOR	2
2	301318	TUBE – SPACER	1
A	152395	BOLT – HEX HD M12X1.75X200-10.9-AA3L	1
B	184714	WASHER – FLAT REG M12-300HV	1
C	136431	NUT – HEX FLG CTR LOC M12X1.75-10	1
D	136755	BOLT – RHSN M16X2X40-8.8-AA1J	4
E	136440	NUT – HEX FLG CTR LK M16X2-10-AA1J	4
F	18603 – see NOTE ¹	WASHER – FLAT SAE 1 1/16 ID X 2.0 OD	4

1. Only two of the four washers (MD #18603) are required for this procedure. You can keep the remaining two washers as spares.

COMPLETING HEADER ASSEMBLY

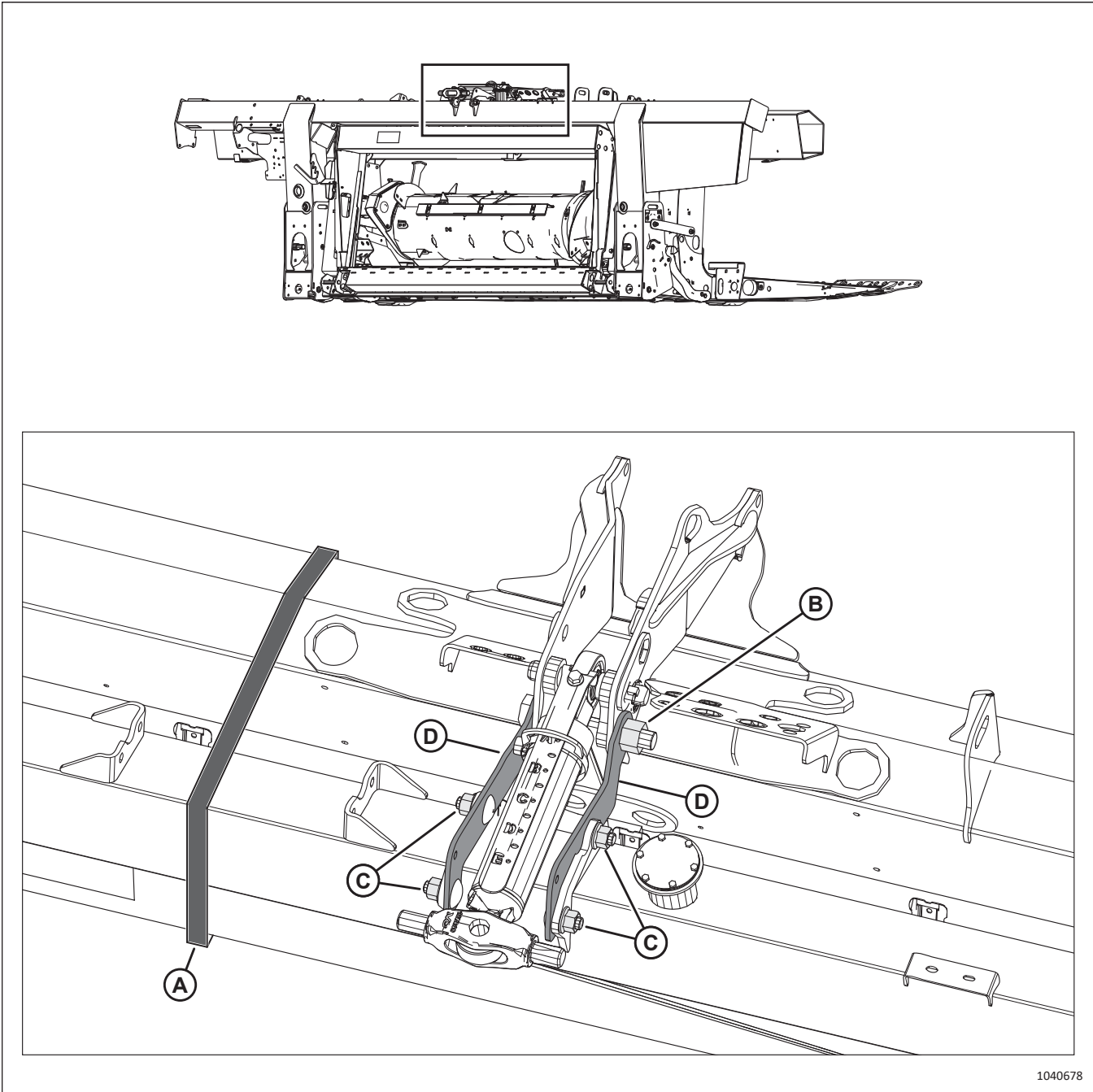

Figure 5.2: Center-Link Installation

2. Install ratchet strap (A) around the float module and the header backtube.
3. Remove nut (B) and bolt. Discard the hardware.
4. Remove four nuts (C) and bolts. Discard the hardware and both brackets (D).

COMPLETING HEADER ASSEMBLY

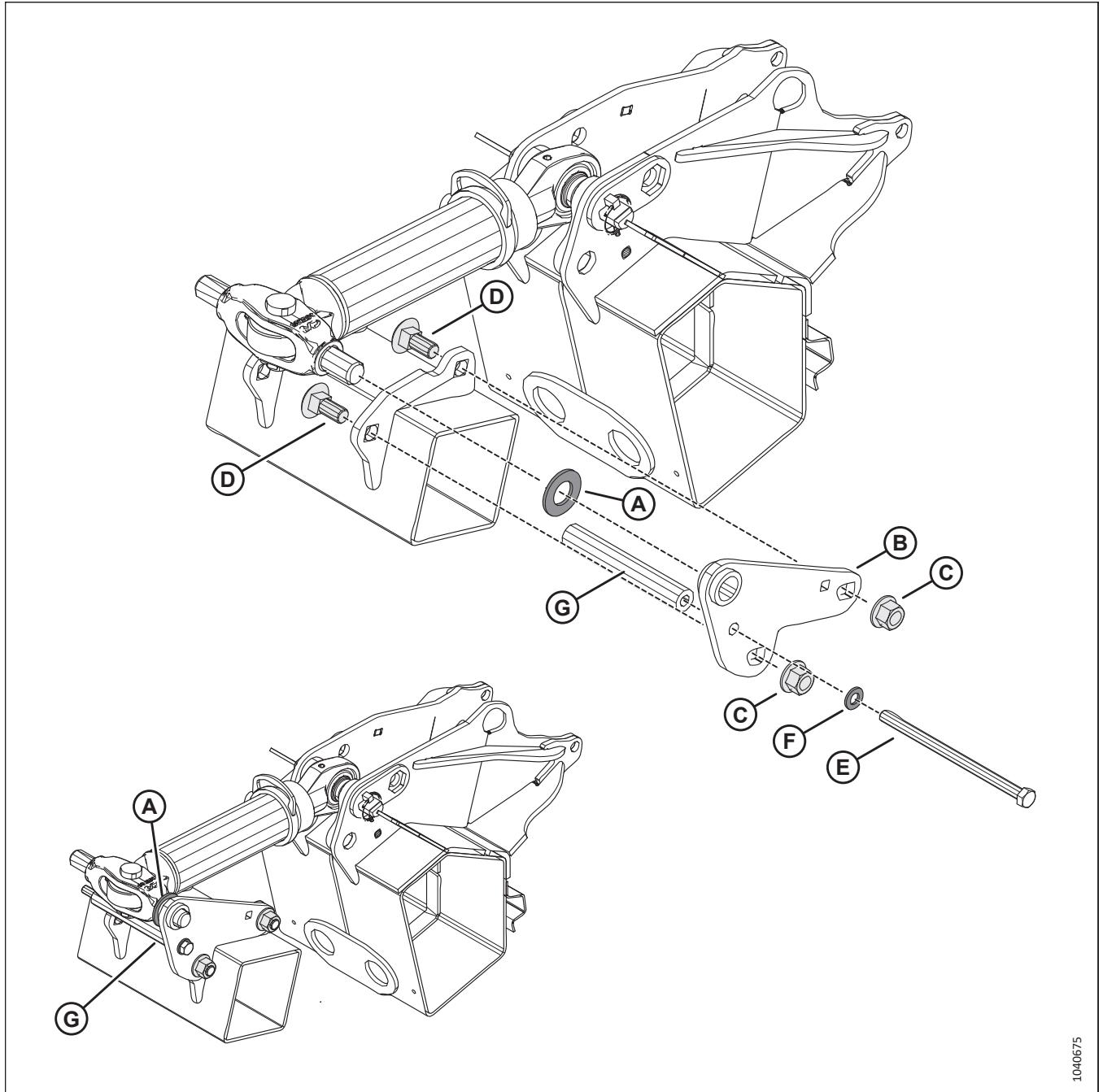
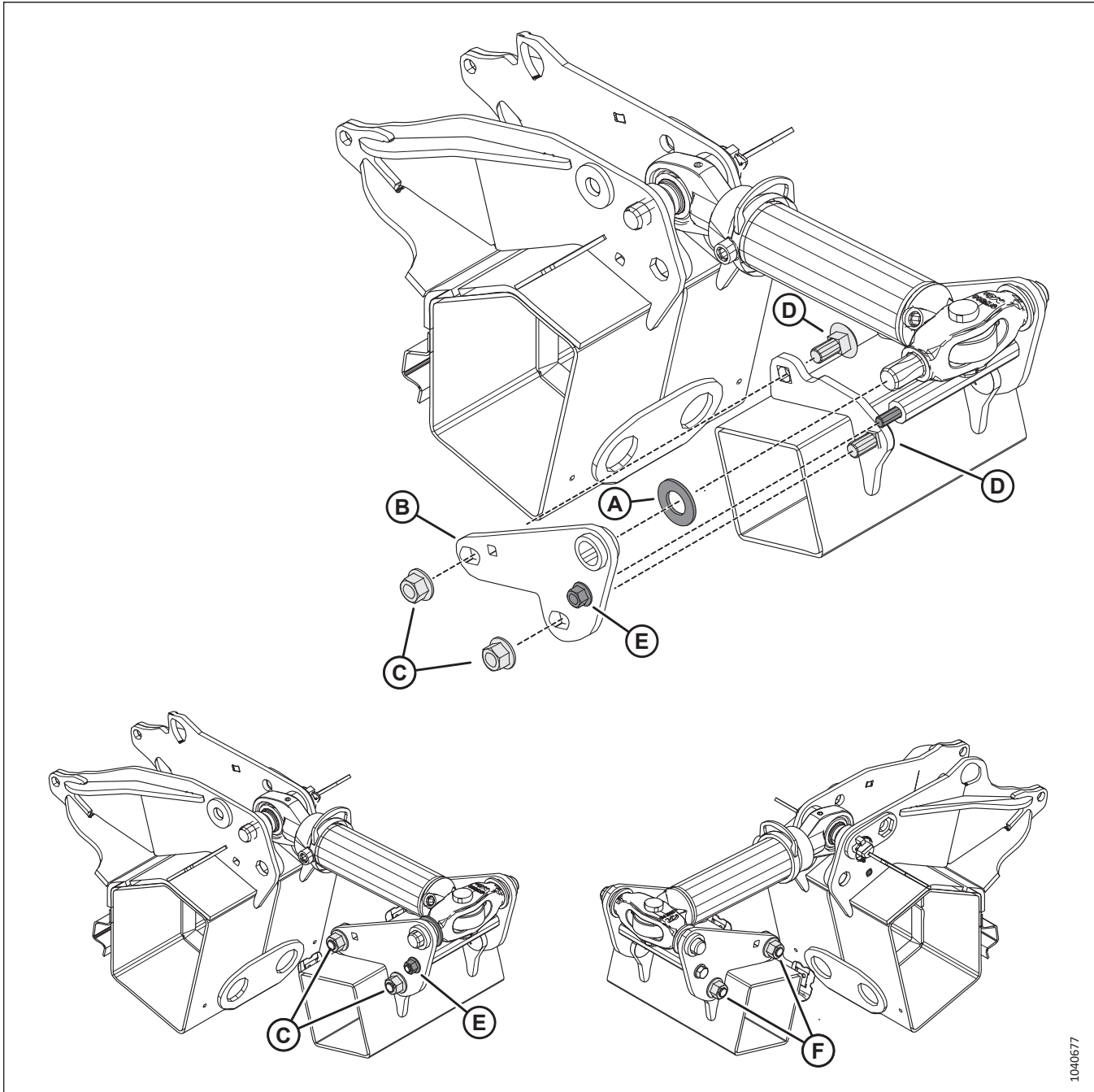

Figure 5.3: Center-Link Installation

5. Install washer (A) (MD #18603) onto the center-link.
6. Attach plate (B) to the float module using two M16 nuts (C) (MD #136440) and carriage head bolts (D) (MD #136755).
7. Insert M12 bolt (E) (MD #152395) through washer (F) (MD #184714), plate (B), and spacer (G).

COMPLETING HEADER ASSEMBLY



1040677

Figure 5.4: Center-Link Installation

8. Install washer (A) onto center-link.
9. Attach plate (B) to the float module using two M16 nuts (C) (MD #136440) and carriage head bolts (D) (MD #136755).
10. Insert M12 nut (E) (MD #136431) onto the spacer bolt.
11. Tighten M16 nuts (C) and (F) to 170 Nm (125 lbf-ft). Tighten M12 nut (E) to 69 Nm (51 lbf-ft).

5.2 Removing Shipping Supports

The shipping stands bolted to the header allow it to be handled safely. These stands are no longer needed after shipping, and must be removed from the header.

DANGER

To prevent injury or death from the unexpected start-up of the machine, always stop the engine and remove the key from the ignition before leaving the operator's seat for any reason.

DANGER

Clear the area of other persons, pets, etc. Keep children away from the machinery. Walk around the machine to be sure no one is under, on, or close to it.

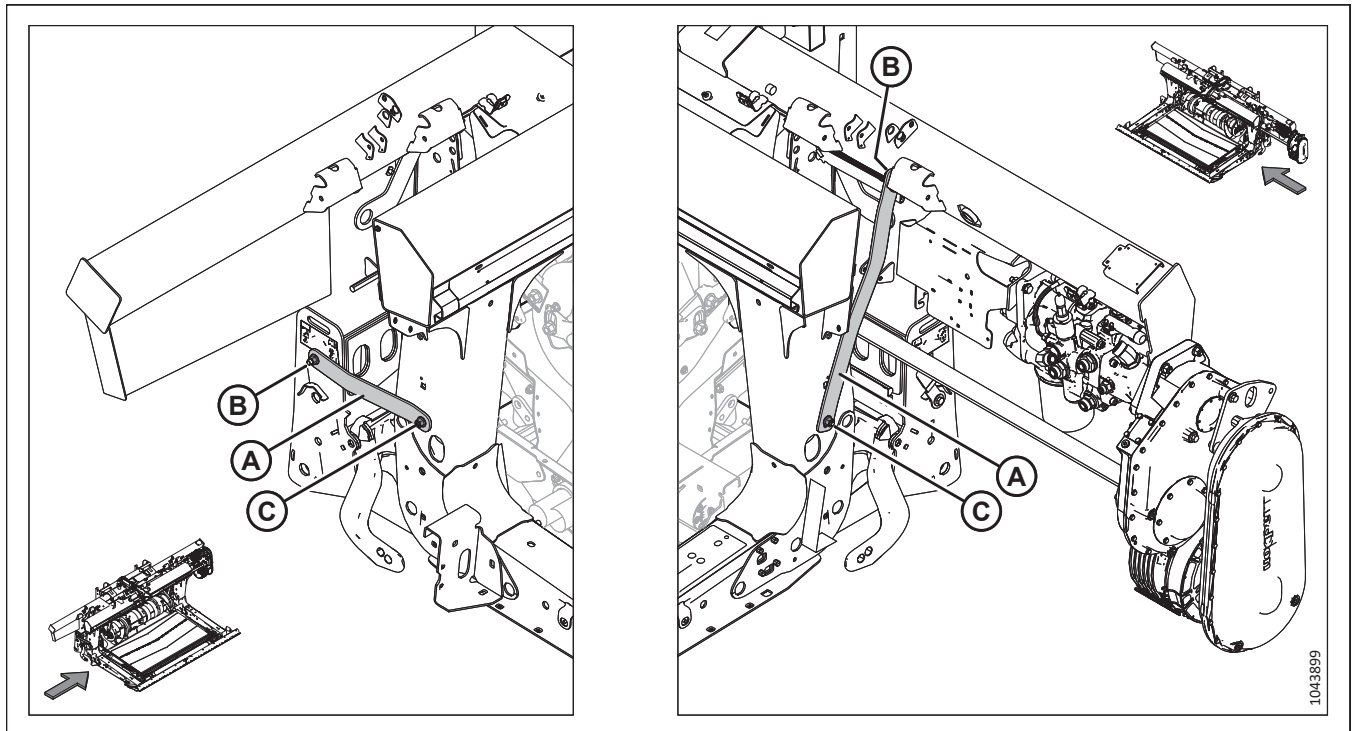

Figure 5.5: Straps on Center Frame

1. Remove straps (A) as follows:

NOTE:

If straps (A) are difficult to remove, lift one end of the header to release the load on the straps so that the bolts can be removed.

- a. Remove and discard rear bolts (B) from straps (A) on both sides of the float module.
- b. Start the engine and use the tilt cylinder to tilt the guard angle.
- c. Shut down the engine, and remove the key from the ignition.
- d. Remove and discard front bolts (C) and straps (A) on both sides of the float module.

5.3 Installing Fore-Aft Indicator and Sensor Spring (Parts Bag MD #368002)

To prevent damage during shipping, the fore-aft indicator parts were removed and will need to be installed.

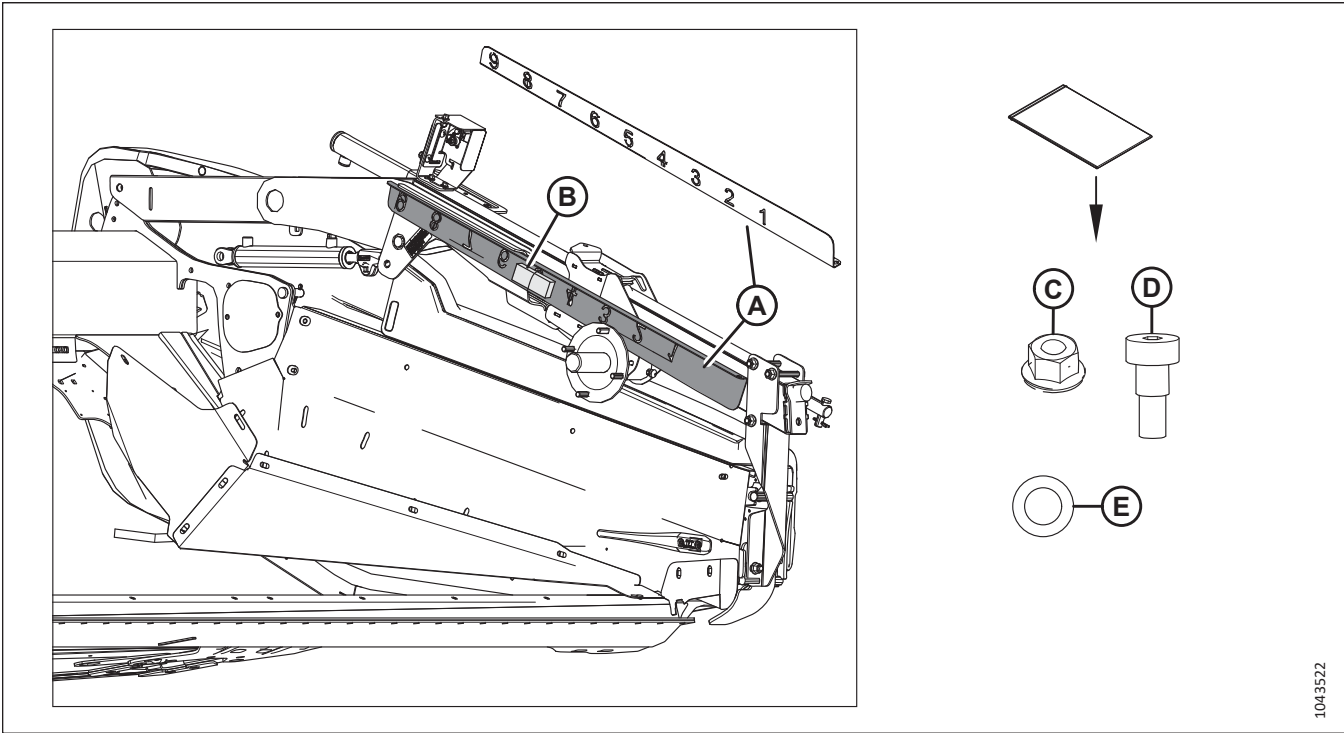

Figure 5.6: Fore-Aft Indicator Shipping Location, Parts Bag MD #368002

1. Retrieve fore-aft indicator (A) and parts bag (B) MD #368002 from the left reel arm. This bag contains the following:
 - One M8 nut (C) MD #135337
 - One M10 hex socket shoulder bolt (D) MD #135894
 - One M10 washer (E) MD #184711

COMPLETING HEADER ASSEMBLY

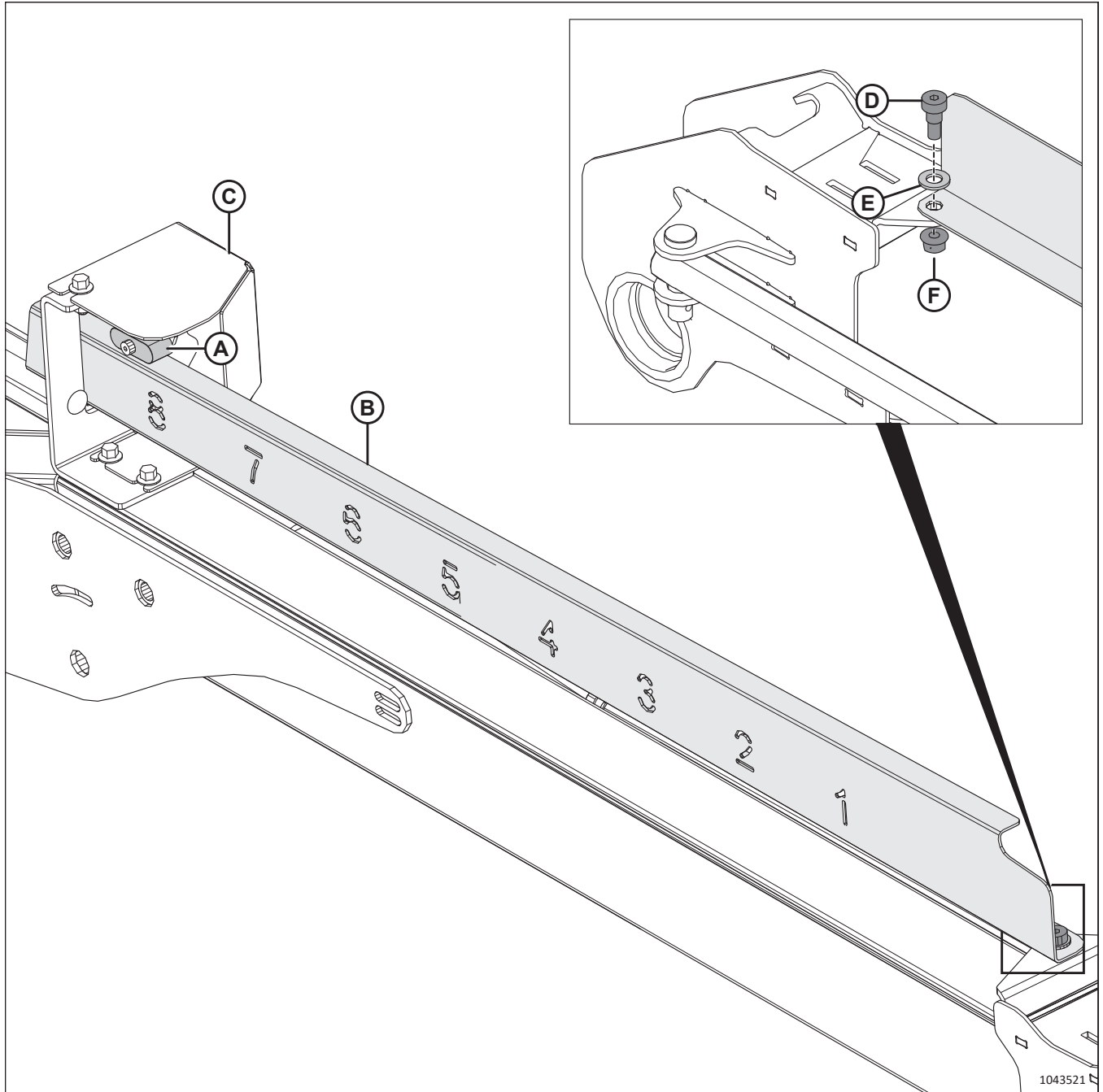

Figure 5.7: Fore-Aft Indicator Installation

2. Lift sensor slider (A) up, and slide fore-aft indicator (B) through sensor bracket (C).
3. Secure the indicator using shoulder bolt (D), washer (E), and M8 nut (F).

NOTE:

The shoulder bolt ensures that the bolt will remain free-spinning.

5.4 Installing Front Support for Right Endshield – D225 (Parts Bag MD #357468)

The front support helps secure the endshield to the header.

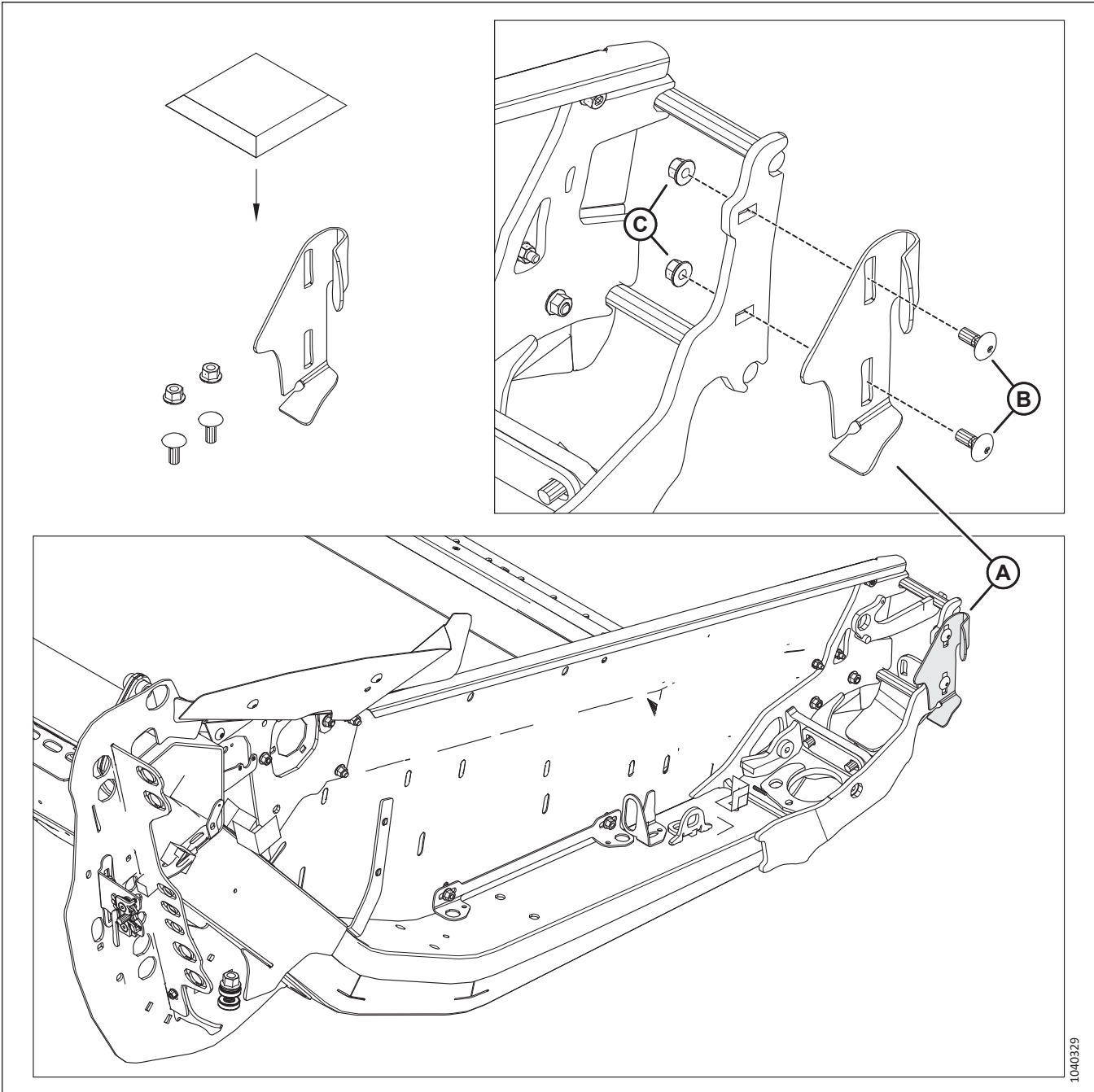

Figure 5.8: Front Support Installation, Parts Bag MD #357468

1. Retrieve parts bag MD #357468.
2. Install front support (A) using two bolts (B) and nuts (C) supplied in the parts bag.

5.5 Installing Reel Lift Cylinders – Single Reel, D225

The left and right reel lift cylinders on single-reel headers have been detached from the reel lift arms for shipping purposes. They will need to be installed on the header.

CAUTION

Do NOT remove reel fore-aft shipping supports (A). The reel fore-aft hydraulic cylinders must be connected to the reel before fore-aft shipping supports (A) can be removed. If the fore-aft shipping supports are removed before the hydraulic cylinders have been connected, the reel can slide forward, which may result in injury.

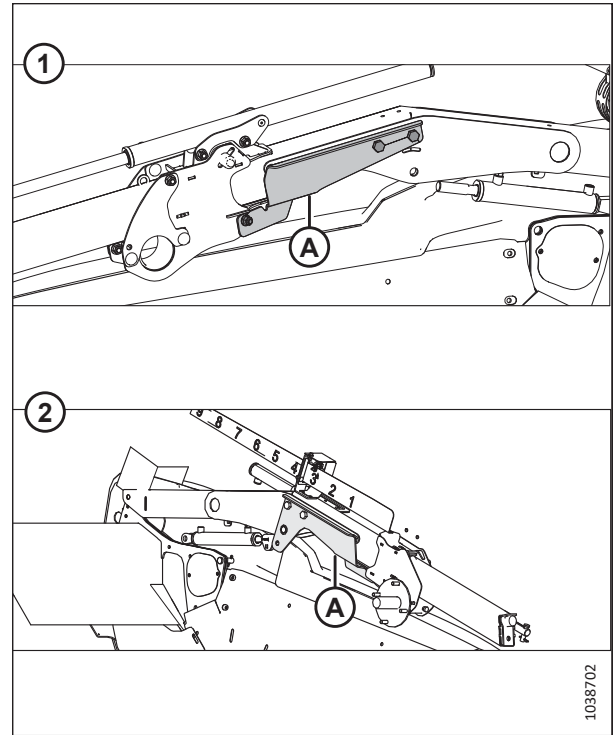

Figure 5.9: Fore-Aft Shipping Supports

1 - Outer Right Reel Arm

2 - Outer Left Reel Arm

1. On left reel arm support (B), remove top two bolts (A).

IMPORTANT:

The top bolts **MUST** be removed from both reel arm supports before the lift cylinders are connected.

2. Repeat the previous step to remove the top two bolts from the right reel arm support.

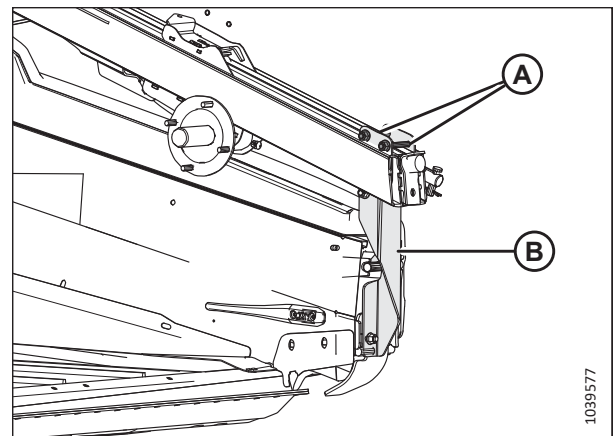

Figure 5.10: Reel Arm Support

COMPLETING HEADER ASSEMBLY

- Retrieve reel lift cylinder (A) from the left reel arm.

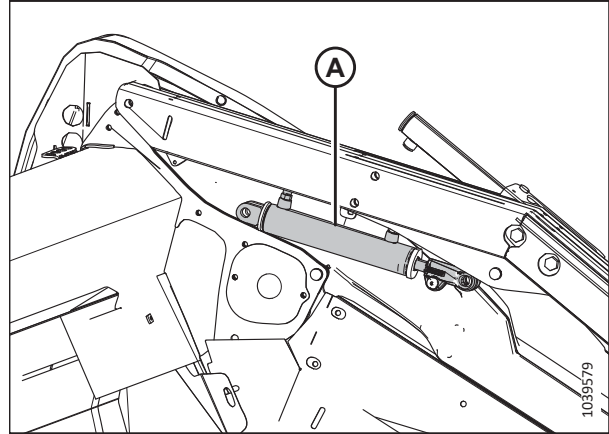

Figure 5.11: Reel Lift Cylinder on Left Reel Arm

- On the left end of the reel, wrap sling (A) around the reel tube as shown. Attach the sling to the fork of a forklift.

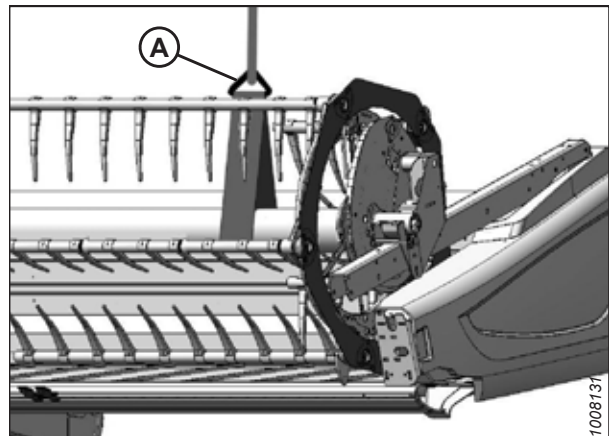

Figure 5.12: Sling Positioned on Left Side of Reel

- Remove and retain two pins (A).
- Use the forklift to lift the reel so that the reel lift cylinder mounting holes line up with the lug on the endsheet and the hole in the reel arm.

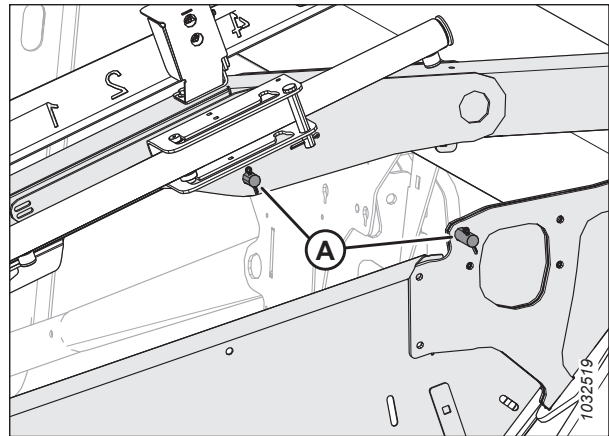

Figure 5.13: Left Reel Lift Cylinder Pins

COMPLETING HEADER ASSEMBLY

7. Install the rod end of lift cylinder (A) and safety prop (B) using clevis pin (C) and cotter pin (D).

IMPORTANT:

Install cotter pin (D) on the outboard side of the header.

8. Move reel safety prop (B) up onto the hook under the reel arm.
9. Secure the base of cylinder (A) to the endsheet using clevis pin (E) and cotter pin (F).

IMPORTANT:

Install cotter pin (F) on the outboard side of the header.

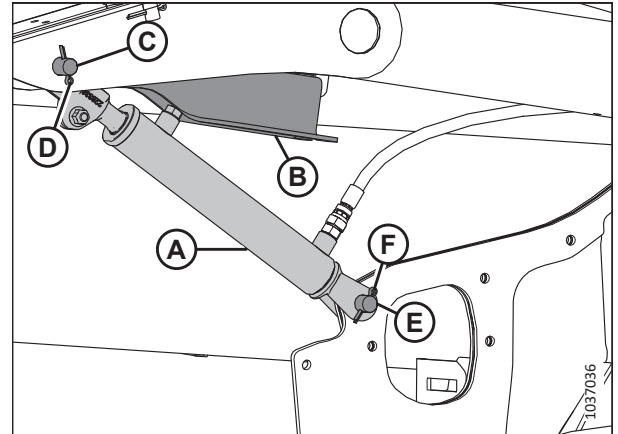

Figure 5.14: Left Reel Lift Cylinder Installed on Header

10. Remove hardware (A) from outboard arm support (B). Remove and discard the support and the hardware.

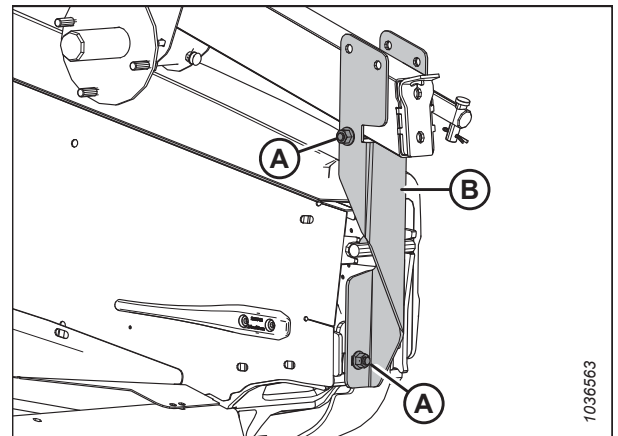

Figure 5.15: Reel Left Arm Support

11. On the right end of the reel, wrap sling (A) around the reel tube as shown. Attach the sling to the fork of a forklift.

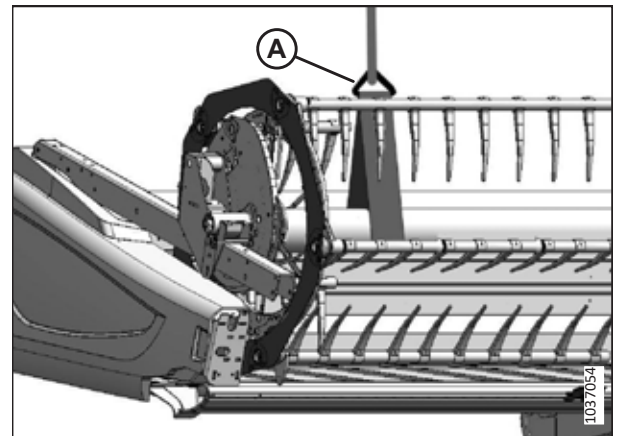

Figure 5.16: Sling Positioned on Right Side of Reel

COMPLETING HEADER ASSEMBLY

- Retrieve reel lift cylinder (A) from the right reel arm.

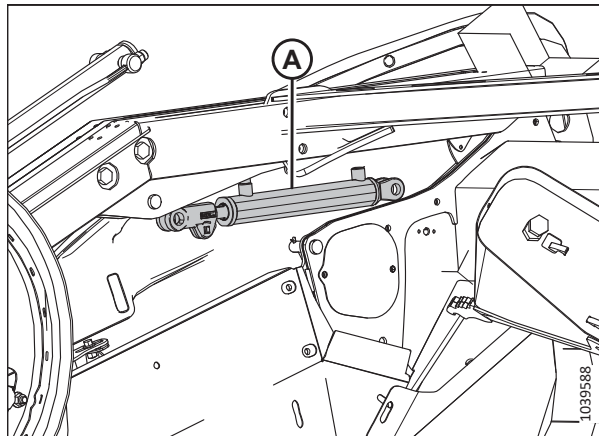

Figure 5.17: Reel Lift Cylinder on Right Reel Arm

- Remove and retain two pins (A).
- Use the forklift to lift the reel so that the reel lift cylinder mounting holes line up with the lug on the endsheet and the hole in the reel arm.

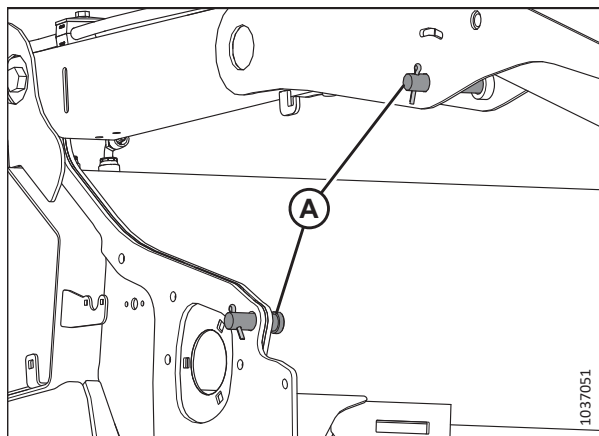

Figure 5.18: Right Reel Lift Cylinder Pins

- Install the rod end of lift cylinder (A) and safety prop (B) using clevis pin (C) and cotter pin (D).

IMPORTANT:

Install cotter pin (D) on the outboard side of the header.

- Move reel safety prop (B) up onto the hook under the reel arm.
- Secure the base of cylinder (A) to the endsheet using clevis pin (E) and cotter pin (F).

IMPORTANT:

Install cotter pin (F) on the outboard side of the header.

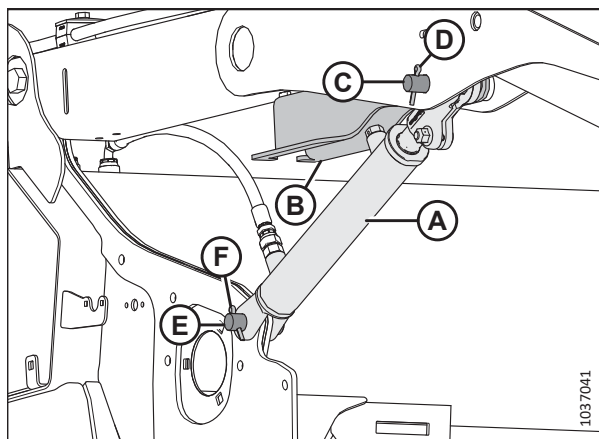

Figure 5.19: Right Lift Cylinder and Safety Prop

COMPLETING HEADER ASSEMBLY

18. Remove hardware (A) from outboard arm support (B).
Discard support (B) and hardware (A).

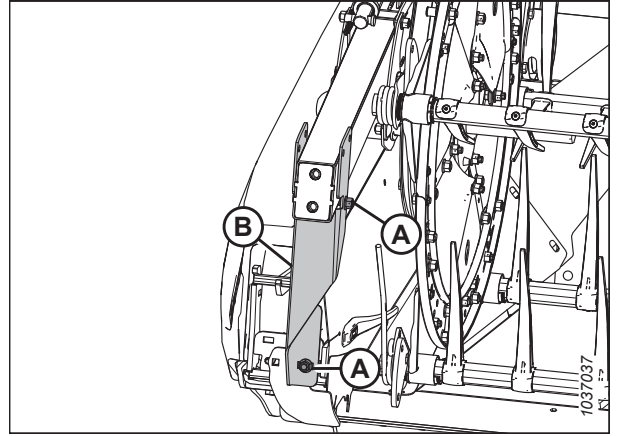

Figure 5.20: Right Reel Arm

5.6 Installing Reel Lift Cylinders – Double Reel, D230 and D235

The left, center, and right reel lift cylinders on double-reel headers have been detached from the reel lift arms for shipping purposes. They will need to be installed on the header.

CAUTION

Do NOT REMOVE reel fore-aft shipping supports (A). The reel fore-aft hydraulic cylinders must be connected to the reel before fore-aft shipping supports (A) can be removed. If the fore-aft shipping supports are removed before the hydraulic cylinders have been connected, the reel can slide forward, which may result in injury.

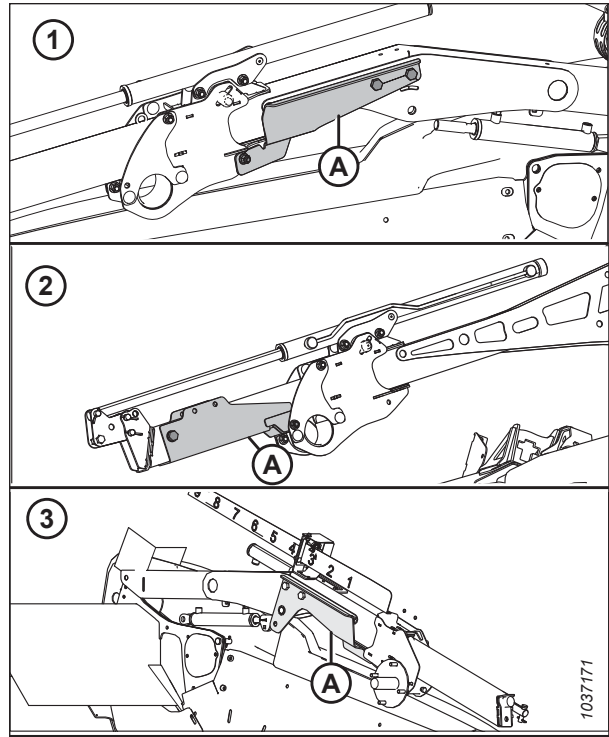

Figure 5.21: Fore-Aft Shipping Supports

1 - Outer Right Reel Arm

2 - Center Reel Arm

3 - Outer Left Reel Arm

1. Remove top two bolts (A) from all three reel arm supports.

IMPORTANT:

The top bolts **MUST** be removed from both reel arm supports before the lift cylinders are connected.

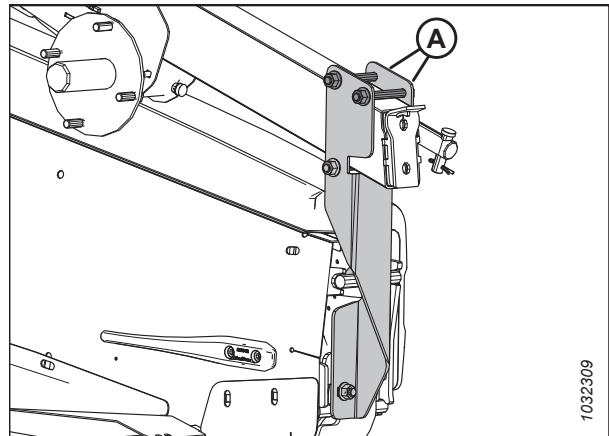

Figure 5.22: Left Reel Arm Shipping Support

COMPLETING HEADER ASSEMBLY

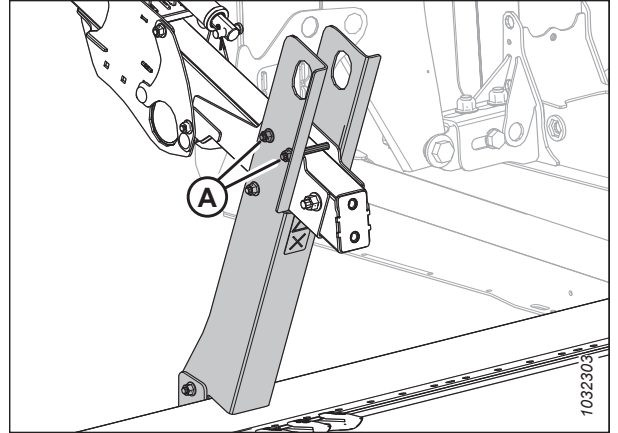

Figure 5.23: Center Arm Shipping Support

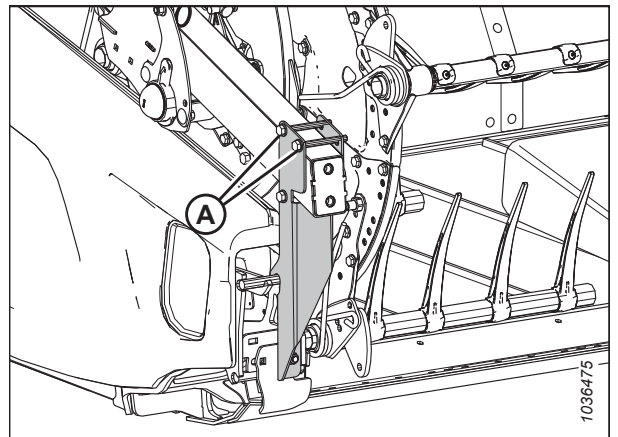

Figure 5.24: Right Reel Arm Shipping Support

2. On the left end of the left reel, wrap sling (A) around the reel tube as shown. Attach the sling to the fork of a forklift.

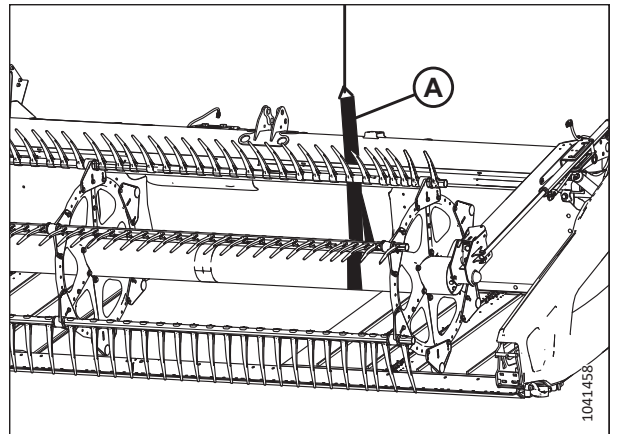

Figure 5.25: Sling Positioned on Left Side of Reel

COMPLETING HEADER ASSEMBLY

3. Remove the shipping wire securing reel lift cylinder (A) to the left reel arm.
4. Remove and set aside the left light assembly strapped to the reel lift cylinder.

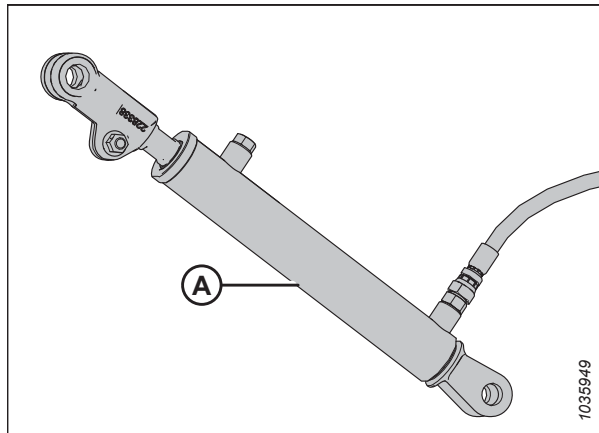

Figure 5.26: Reel Lift Cylinder

5. Remove and retain two sets of pins (A) from the lug on the endsheet and the reel arm.

NOTE:

The safety prop may fall when the upper pin is removed.

6. Use the forklift to lift the reel so that the reel lift cylinder mounting holes line up with the lug on the endsheet and the hole in the reel arm.

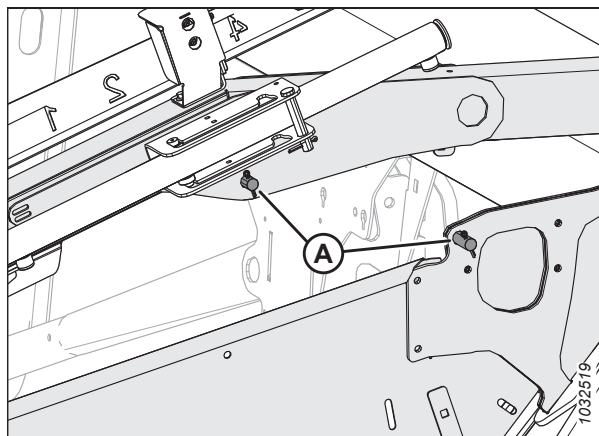

Figure 5.27: Left Reel Lift Cylinder Pins

7. Install the rod end of lift cylinder (A) and safety prop (B) using clevis pin (C) and cotter pin (D).

IMPORTANT:

Install cotter pin (D) on the outboard side of the header.

8. Move reel safety prop (B) up onto the hook under the reel arm.
9. Secure the base of cylinder (A) to the endsheet using clevis pin (E) and cotter pin (F).

IMPORTANT:

Install cotter pin (F) on the outboard side of the header.

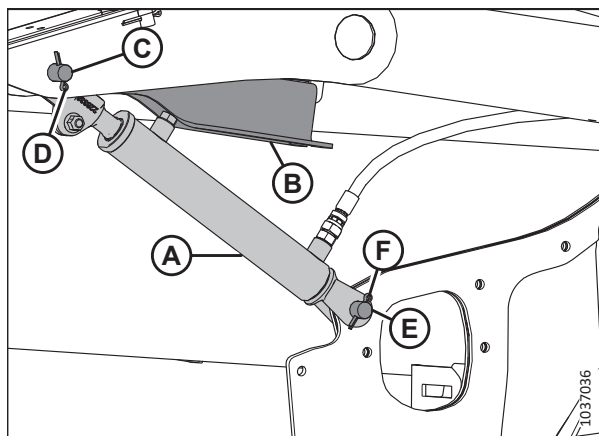

Figure 5.28: Left Reel Lift Cylinder

COMPLETING HEADER ASSEMBLY

10. Remove hardware (A) from outboard arm support (B). Discard support (B) and hardware (A).

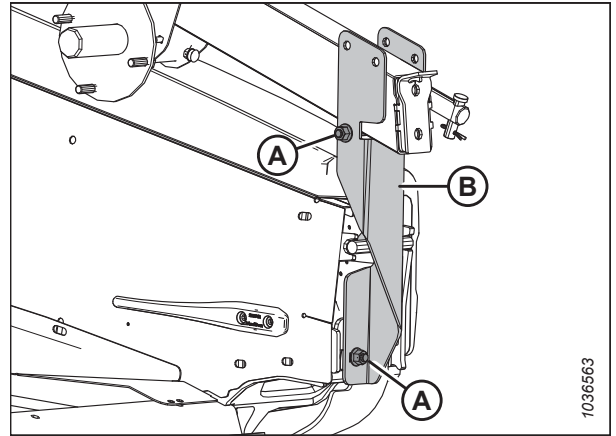

Figure 5.29: Shipping Support – Left Reel Arm

11. Reposition sling (A) near the reel center support arm.

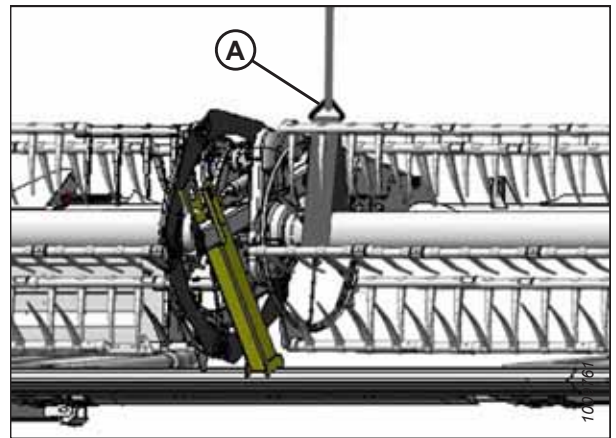

Figure 5.30: Center Reel Arm Shipping Support

12. Remove the shipping wires securing lift cylinders (A) to the center reel arm.
13. Remove and retain the pins from the rod ends of both lift cylinders.

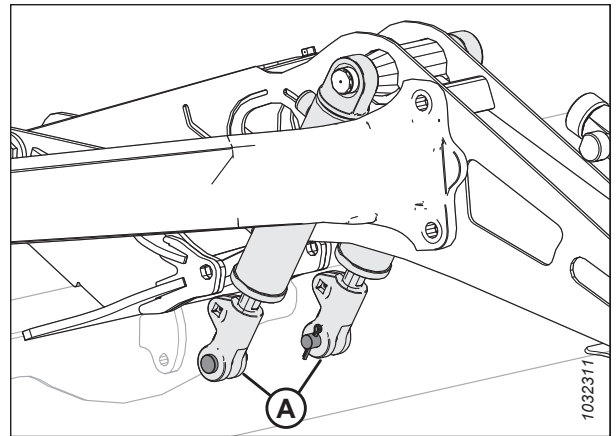

Figure 5.31: Lift Cylinders Secured to Center Reel Arm

COMPLETING HEADER ASSEMBLY

14. Use the forklift to lift the reel. Align the holes on cylinders (A) with the holes on the reel support plates. Secure the cylinders with clevis pins and cotter pins (B).

IMPORTANT:

Install cotter pins (B) on the inboard side as shown.

15. Ensure that the hydraulic fittings on cylinders (A) are tight.

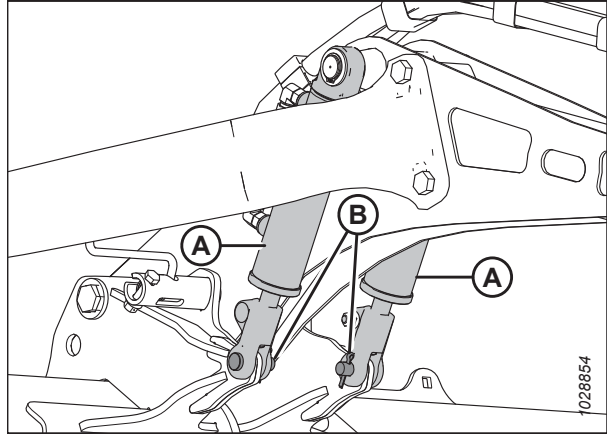

Figure 5.32: Lift Cylinders at Center Reel Arm

16. At the center arm, remove and discard bolts (A) and bolts (B).

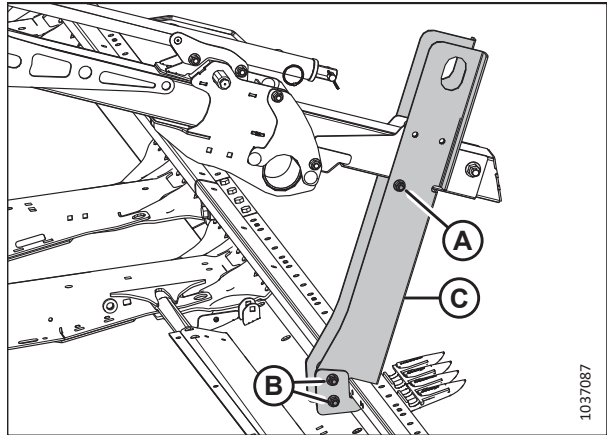

Figure 5.33: Center Reel Arm Support

17. On the right end of the right reel, wrap sling (A) around the reel tube as shown. Attach the sling to the fork of a forklift.

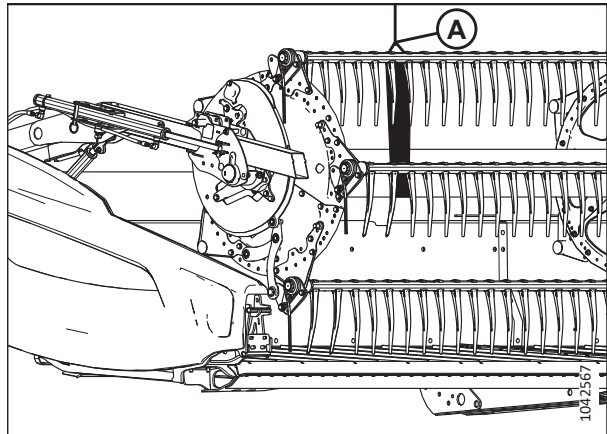

Figure 5.34: Sling Positioned on Right Side of Reel

COMPLETING HEADER ASSEMBLY

18. Remove the shipping wire securing reel lift cylinder (A) to the right reel arm.
19. Remove and set aside the right light assembly strapped to the reel lift cylinder.

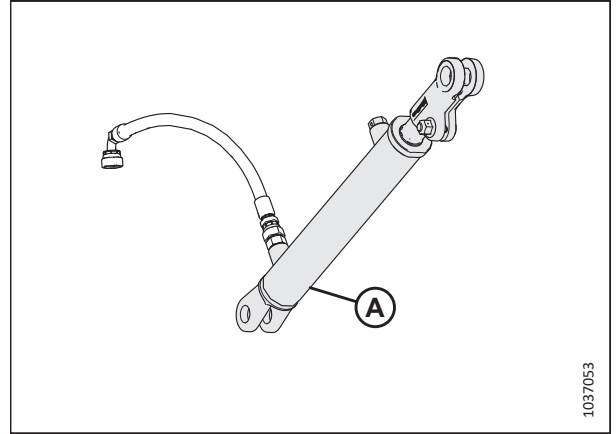

Figure 5.35: Reel Lift Cylinder

20. Remove and retain two sets of pins (A) from the lug on the endsheet and the reel arm.

NOTE:

The safety prop may fall when the upper pin is removed.

21. Lift the reel so that the reel lift cylinder mounting holes line up with the lug on the endsheet and the hole in the reel arm.

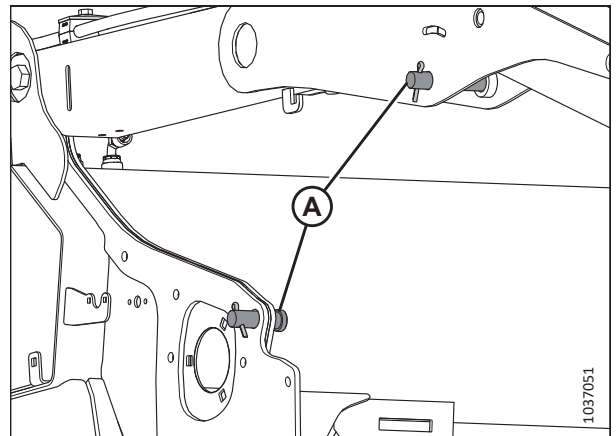

Figure 5.36: Right Reel Arm Lift Cylinder Pins

22. Install rod end of lift cylinder (A) and safety prop (B) using clevis pin (C) and cotter pin (D).

IMPORTANT:

Install cotter pin (D) on the outboard side of the header.

23. Move reel safety prop (B) up onto the hook under the reel arm.
24. Secure the base of cylinder (A) to the endsheet using clevis pin (E) and cotter pin (F).

IMPORTANT:

Install cotter pin (F) on the outboard side of the header.

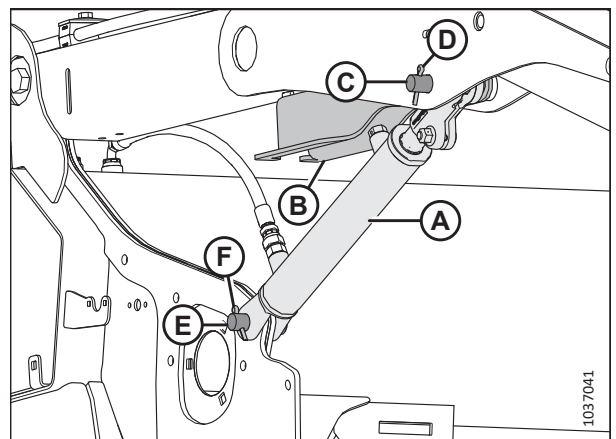

Figure 5.37: Right Lift Cylinder Installed on Reel Arm

COMPLETING HEADER ASSEMBLY

25. Remove hardware (A) from right reel arm support (B).
Discard support (B) and hardware (A).

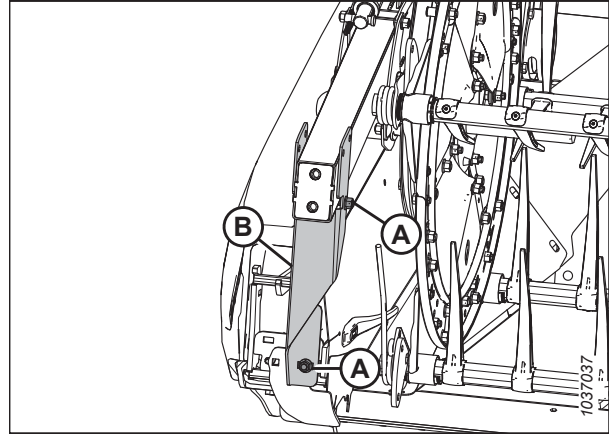

Figure 5.38: Right Reel Arm Shipping Support

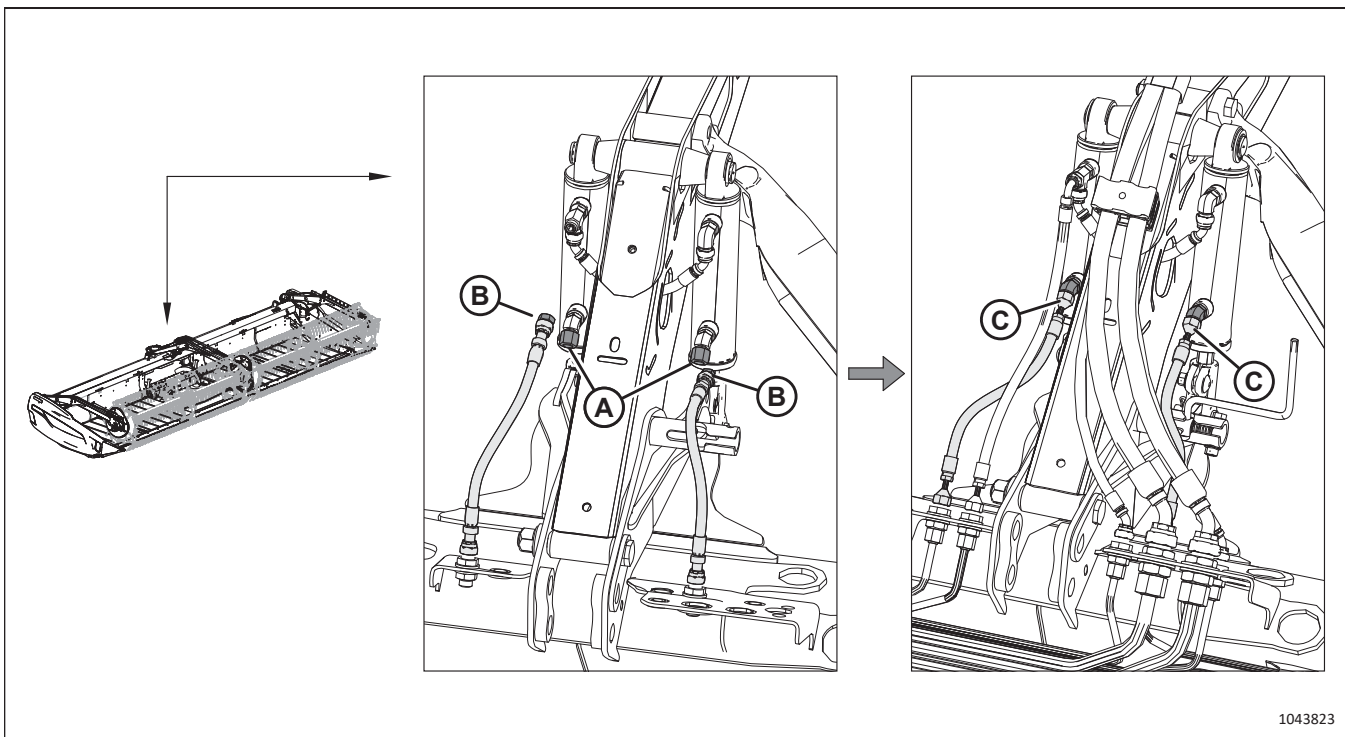

Figure 5.39: Center Reel Arm

26. At the center reel arm, remove caps (A) from the lift cylinders.
27. Remove caps (B) from both reel lift hoses.
28. Connect reel lift hoses (C) to the cylinders.

5.7 Installing Deck Cutterbar Seals – D230 (Parts Bag MD #335987)

Two cutterbar seals were removed from the center of the cutterbar for shipping purposes. They will need to be installed.

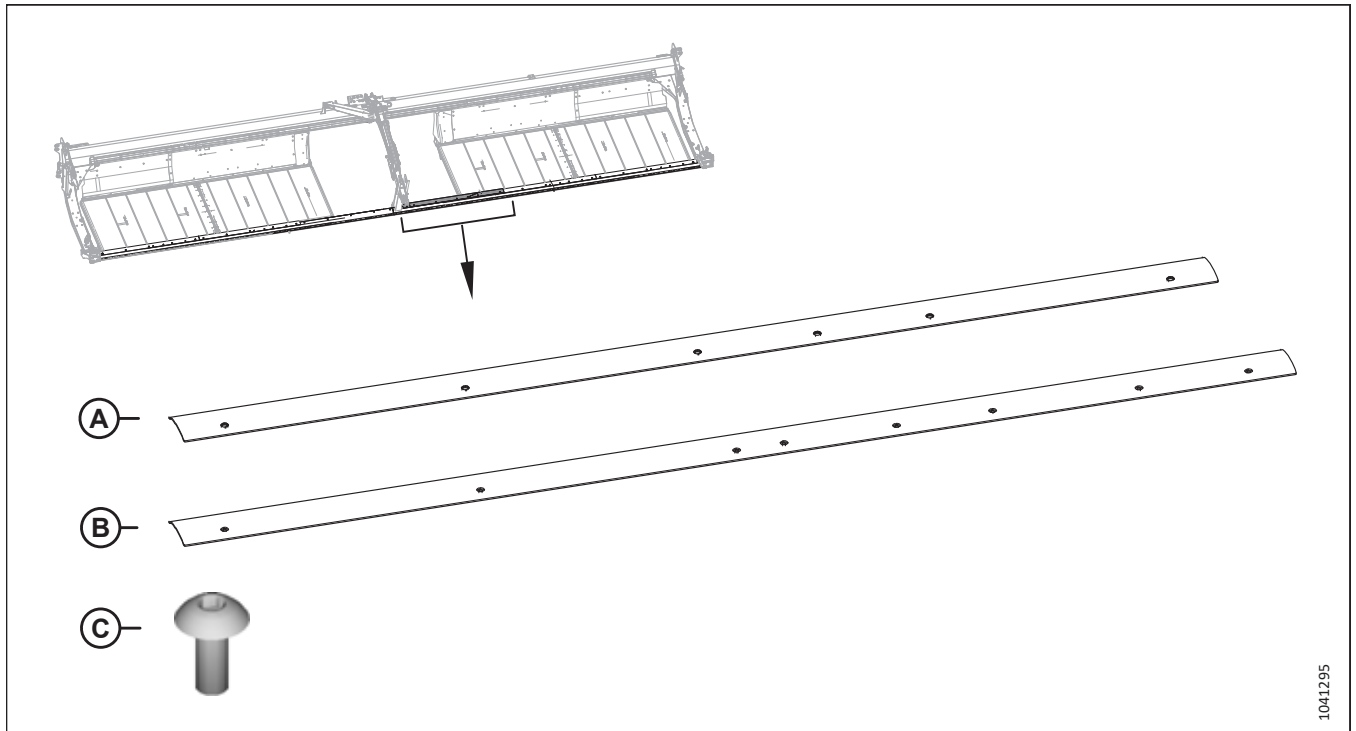

Figure 5.40: Cutterbar Seals and Hardware

1. Retrieve the following parts shipped wired to the cutterbar:
 - Short seal (A)
 - Long seal (B)
 - Parts bag MD #335987, which contains ten M8 Torx[®] screws (C) (MD #320190)

COMPLETING HEADER ASSEMBLY

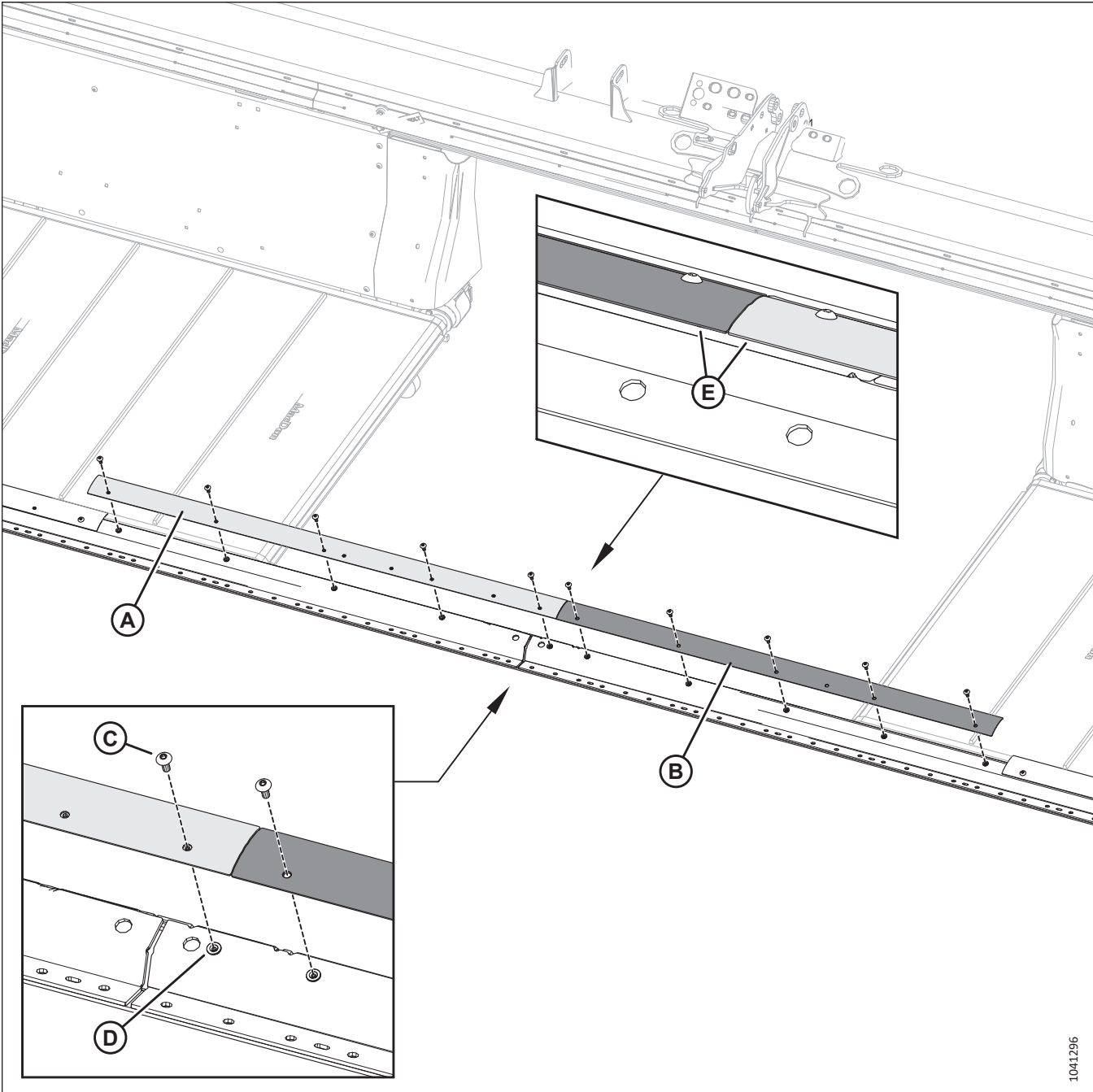

Figure 5.41: Draper Seals – Right Deck

2. Secure longer (A) and shorter (B) seals using five Torx® screws (C) and rivnuts (D) per seal.
3. Tighten all Torx® screws to 29 Nm (21 lbf-ft [257 lbf-in]).
4. Make sure back edges (E) of the seals are aligned with each other. To align the seals, bend them.

COMPLETING HEADER ASSEMBLY

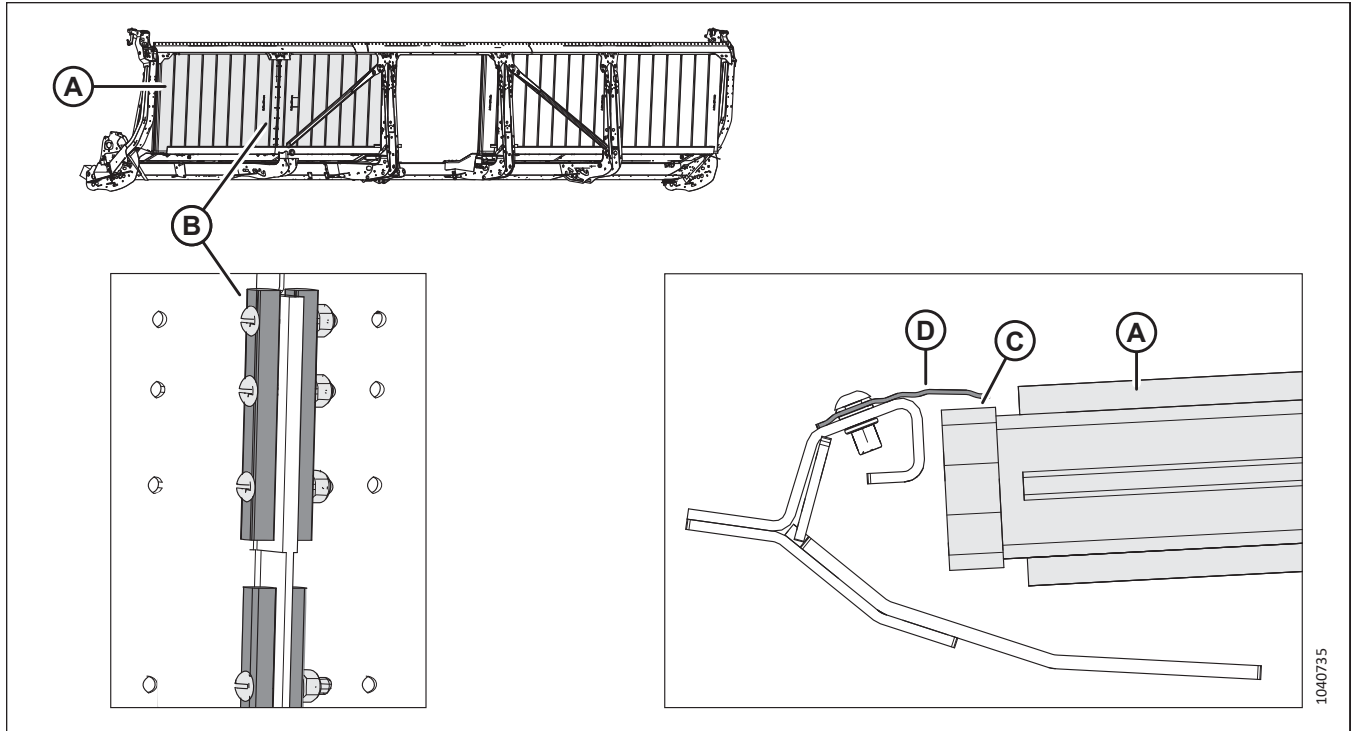

Figure 5.42: Draper Seal Clearance Specifications

5. Move draper (A) so that connector bar (B) is on the bottom of the header.
6. Ensure that clearance (C) between draper (A) and metal seal (D) is 1–4 mm (0.04–0.16 in.).
7. If the draper clearance is not within the correct range, adjust the deck height. For instructions, refer to [10.2 Adjusting Side Draper Deck Height, page 517](#).

5.8 Installing Deck Cutterbar Seal – D235 (Parts Bag MD #335988)

One cutterbar seal was removed from the center of the cutterbar for shipping purposes. It will need to be installed.

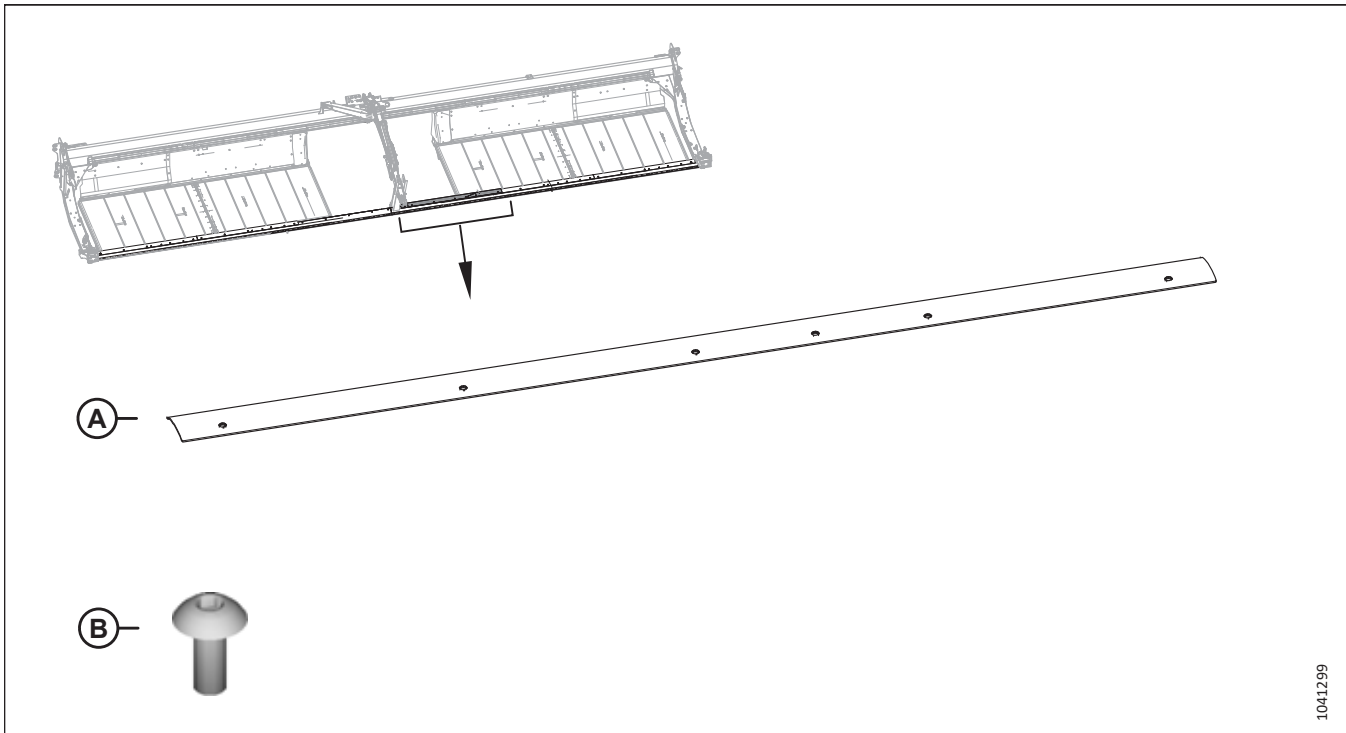

Figure 5.43: Cutterbar Seal and Hardware

1. Retrieve the following parts shipped wired to the cutterbar:
 - Seal (A)
 - Parts bag MD #335988, which contains five M8 Torx[®] screws (B) (MD #320190)

1041299

COMPLETING HEADER ASSEMBLY

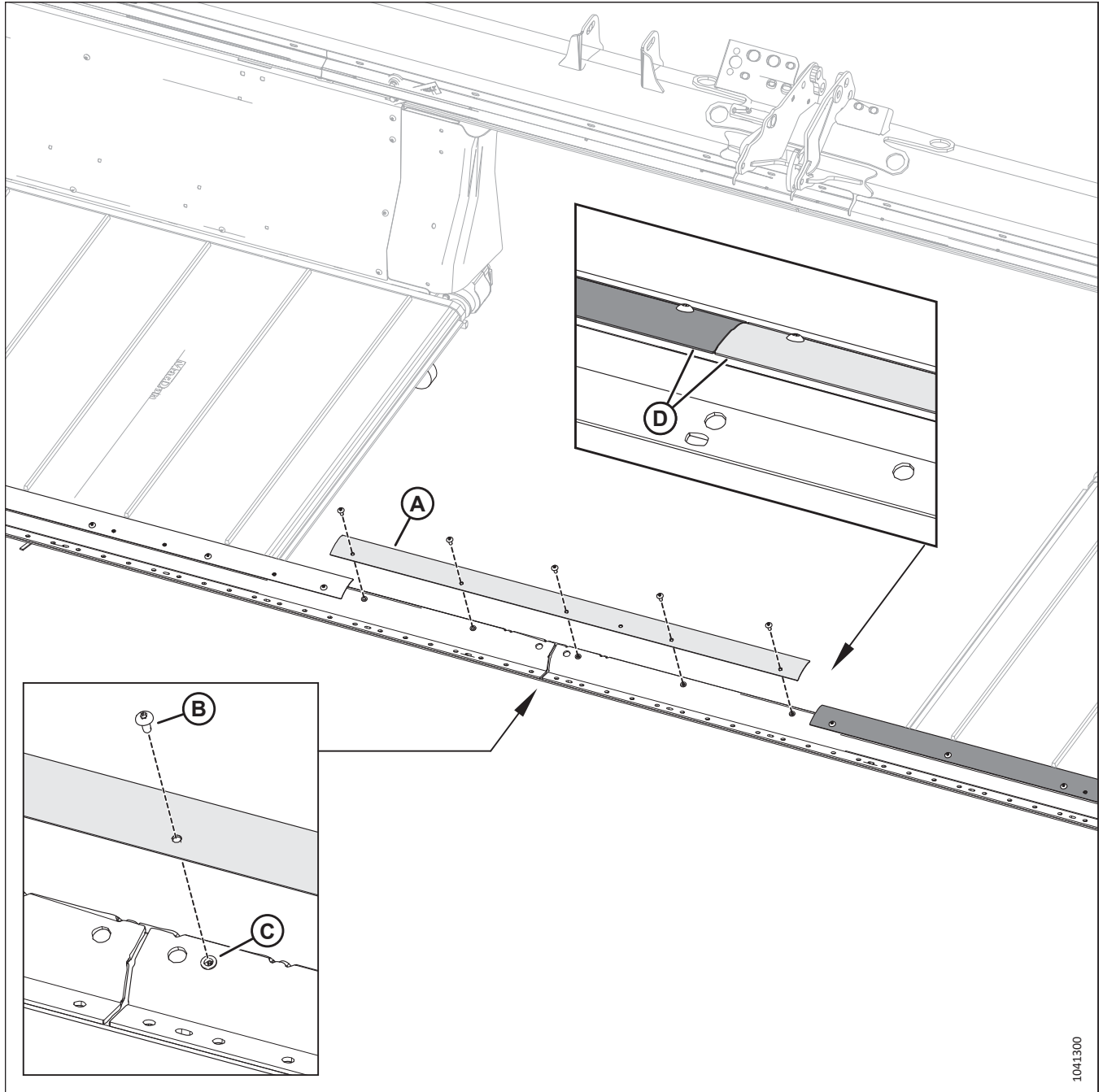

Figure 5.44: Draper Seals – Right Deck

2. Secure seal (A) using five Torx® screws (B) and rivnuts (C).
3. Tighten all Torx® screws to 29 Nm (21 lbf-ft [257 lbf-in]).
4. Make sure back edges (D) of the seals are aligned with each other. To align the seals, bend them.

COMPLETING HEADER ASSEMBLY

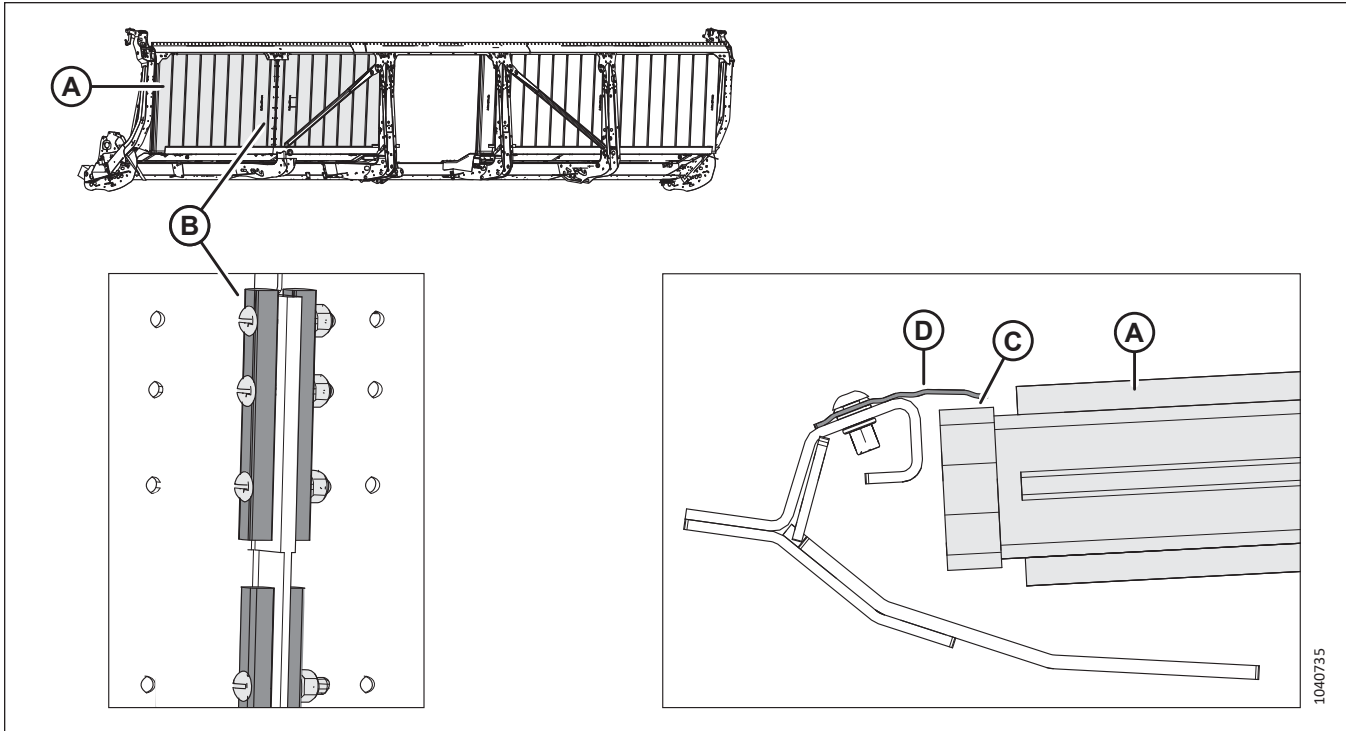

Figure 5.45: Draper Seal Clearance Specifications

5. Move draper (A) so that connector bar (B) is on the bottom of the header.
6. Ensure that clearance (C) between draper (A) and metal seal (D) is 1–4 mm (0.04–0.16 in.).
7. If the draper clearance is not within the correct range, adjust the deck height. For instructions, refer to [10.2 Adjusting Side Draper Deck Height, page 517](#).

5.9 Installing Knifehead Guard Hardware (Parts Bag MD #347581)

The knifehead guards are shipped partially installed on the header.

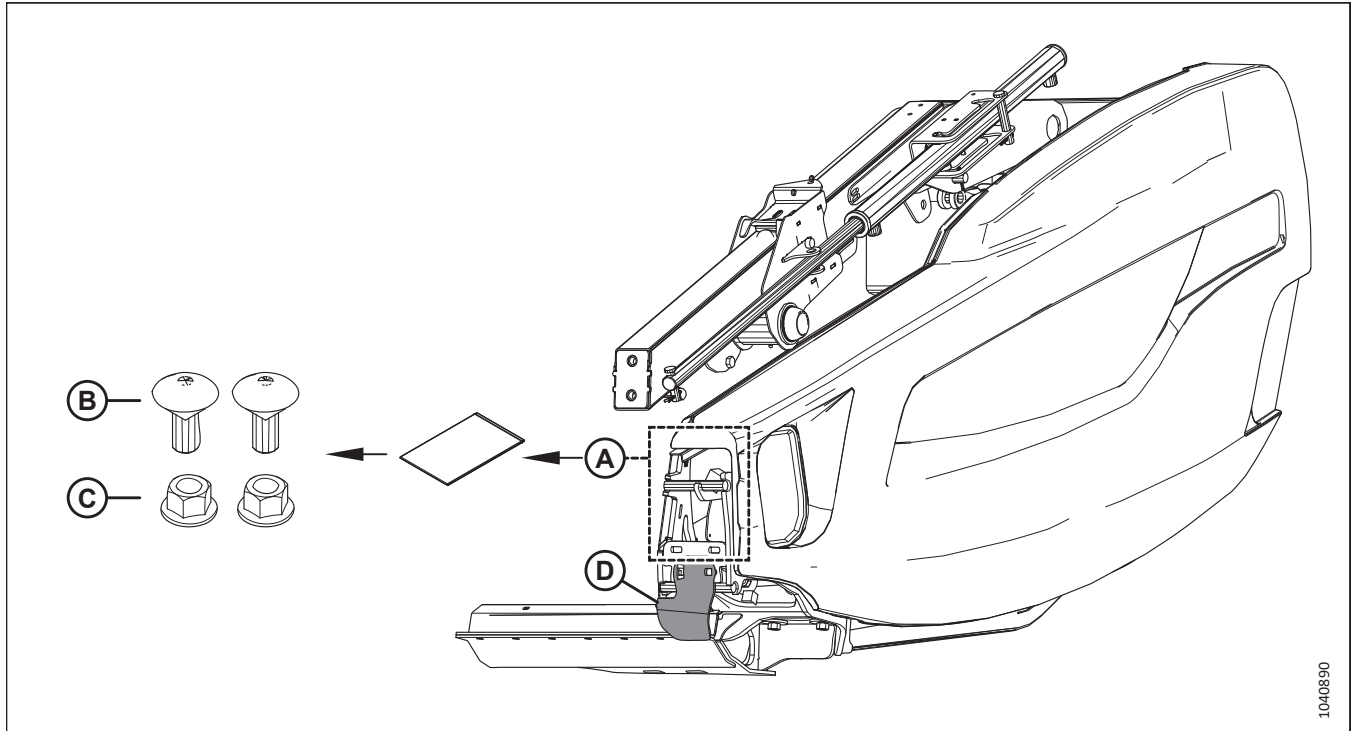

Figure 5.46: Parts Bag MD #347581

1. Retrieve parts bag MD #347581 from location (A). This bag contains the following hardware for the left knifehead guard (D) and the right knifehead guard (not shown):
 - Two M12 x 30 mm bolts (B)
 - Two M12 nuts (C)
2. Position left knifehead guard (A) as close as possible to the bottom of guard (C). The inboard edge of guard (A) should be in line with or just inboard of the center of the first guard point (C).
3. Secure left knifehead guard (A) with one M12 bolt (B) and nut.

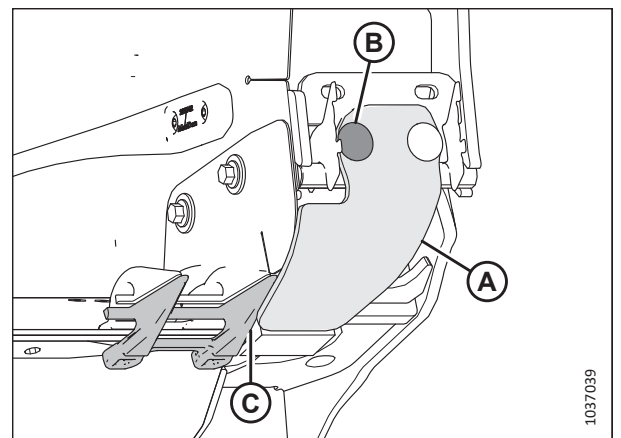

Figure 5.47: Left Knifehead Guard

COMPLETING HEADER ASSEMBLY

4. Position right guard (A) as close as possible to the bottom of guard (C). The inboard edge of guard (A) should be in line with or just inboard of the center of the first guard point (C).
5. Secure right knifehead guard (A) with one M12 bolt (B) and nut.

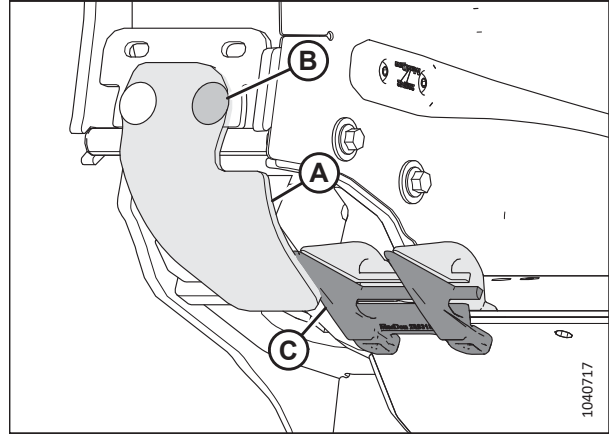

Figure 5.48: Right Knifehead Guard

5.10 Installing Skid Shoes – D225 (Parts Bag MD #357993)

Install the two skid shoes that were removed for shipping purposes.

1. Retrieve parts bag MD #357993. For a list of parts, refer to Table 5.2, page 121.

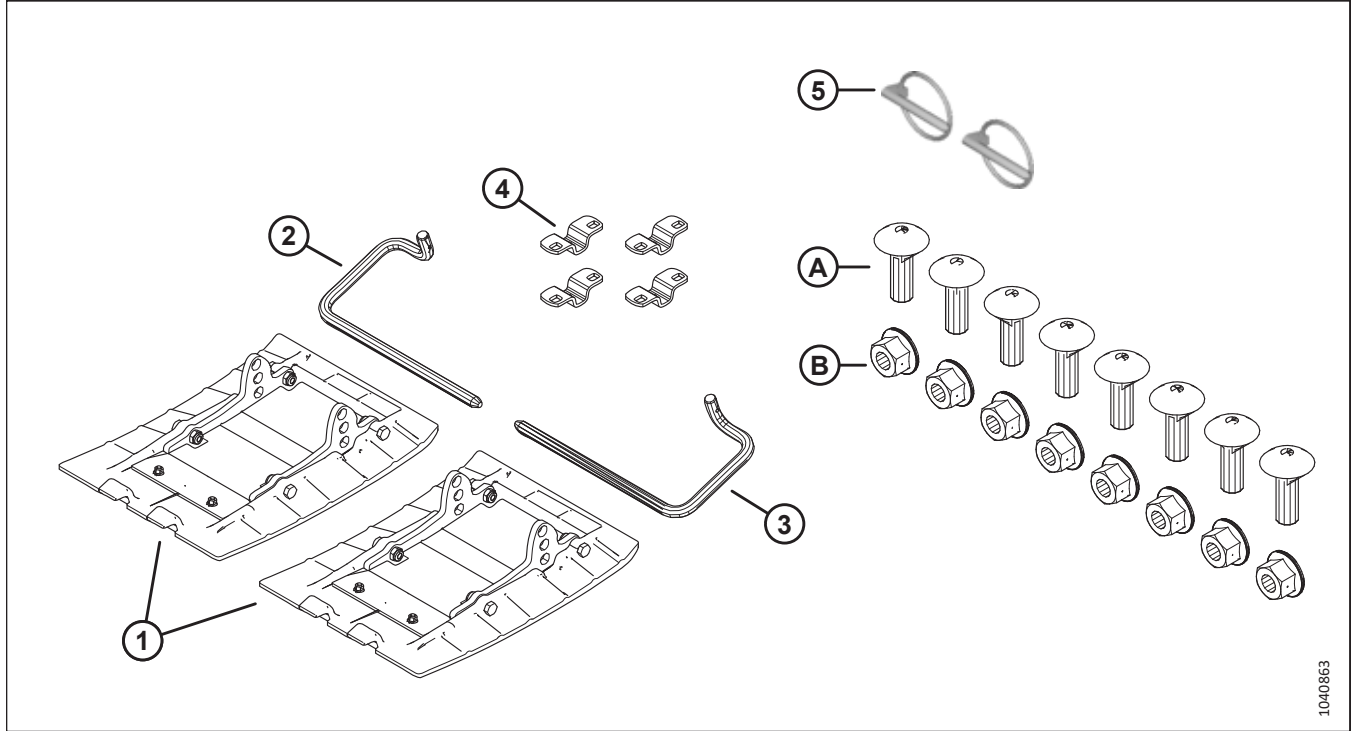

Figure 5.49: Parts Bag MD #357993

Table 5.2 Parts Bag MD #357993

Ref	Part Number	Description	Quantity
1	289761	ASSEMBLY – SKID SHOE	2
2	165588	ROD – ENGAGING RH	1
3	165168	ROD – ENGAGING LH	1
4	232806	BRACKET – SHOE SUPPORT	4
5	50193	PIN – LYNCH	2
A	184662	BOLT – RHSN TFL M10 X 1.5 X 30-8.8-AA1J	8
B	135799	NUT – HEX FLG CTR LOC M10 X 1.5-10	8

COMPLETING HEADER ASSEMBLY

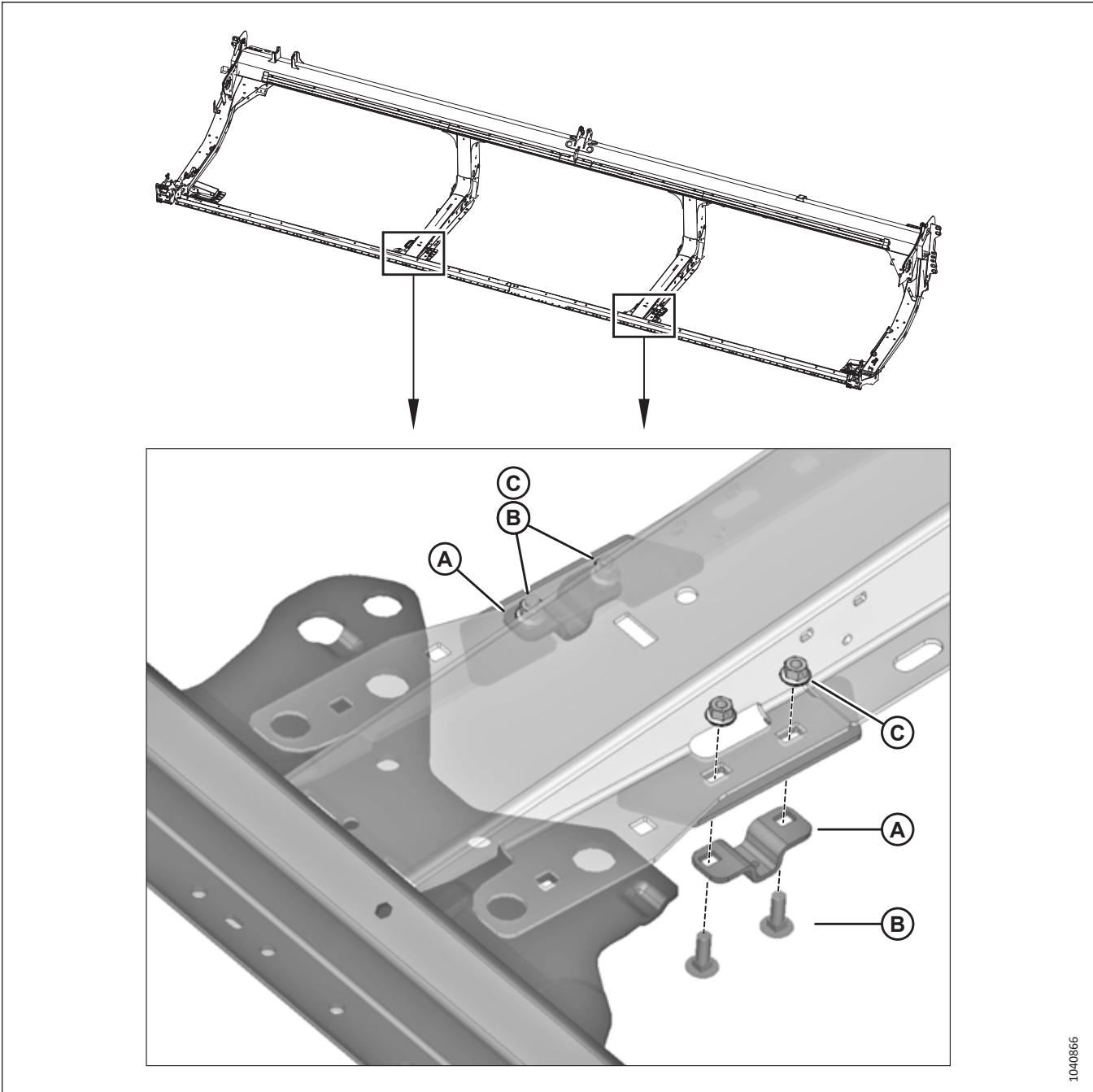

Figure 5.50: Support Bracket Installation

2. Attach two support brackets (A) to both center legs using two bolts (B) and M10 nuts (C) per bracket. Do **NOT** fully tighten nuts (C) yet.

COMPLETING HEADER ASSEMBLY

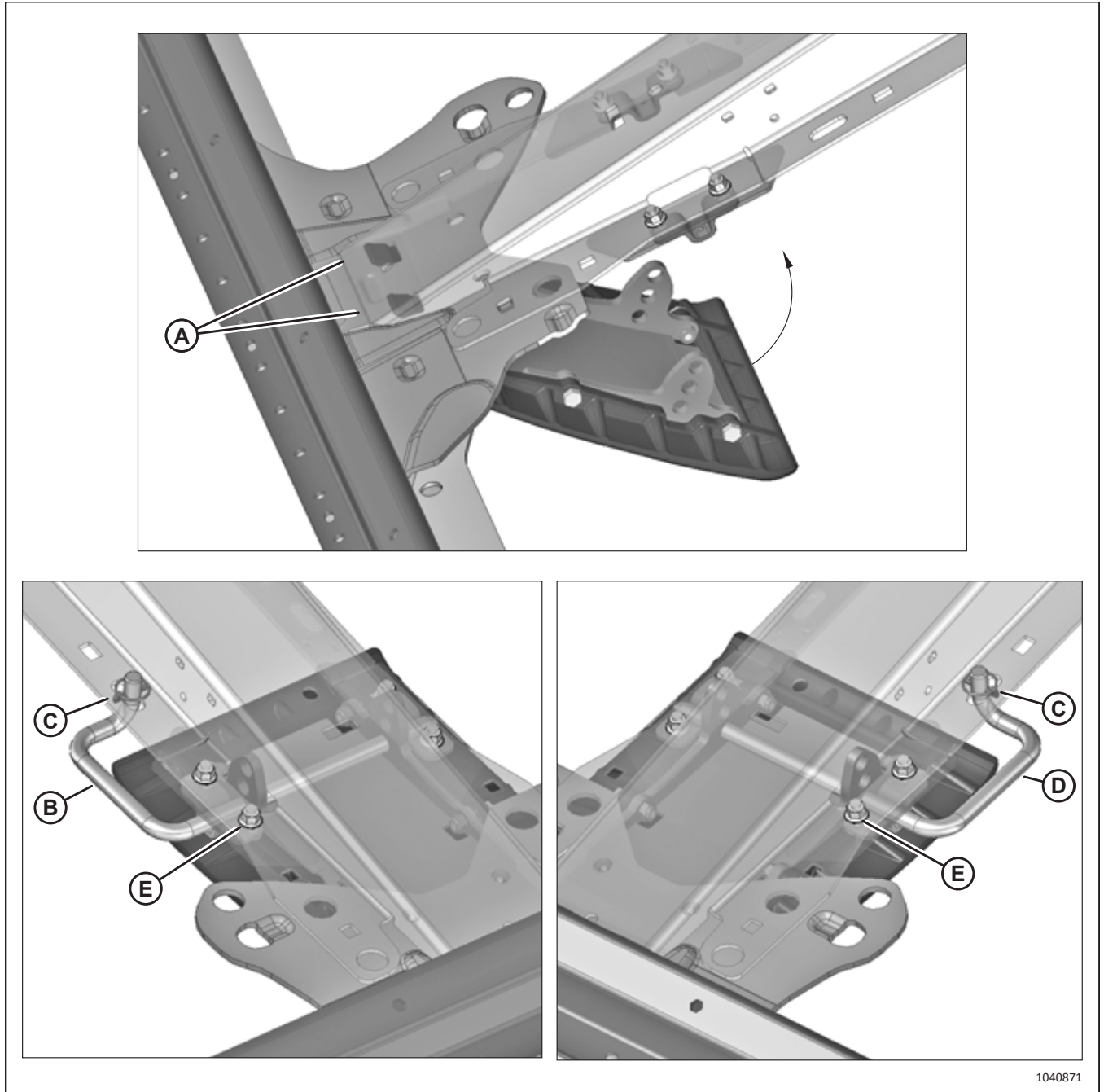

Figure 5.51: Skid Shoe Installation

3. Hook skid shoe tabs (A) into the frame and rotate the shoe upward.
4. Insert the rod through the header leg, support brackets, and skid shoe holes as shown:
 - Rod (B) is for the right leg
 - Rod (D) is for the left leg
5. Secure the rod with pin (C). Push the skid shoe as far forward as possible, and then tighten all bracket nuts (E).
6. Repeat Step 3, page 123 to Step 5, page 123 for the other skid shoe.

COMPLETING HEADER ASSEMBLY

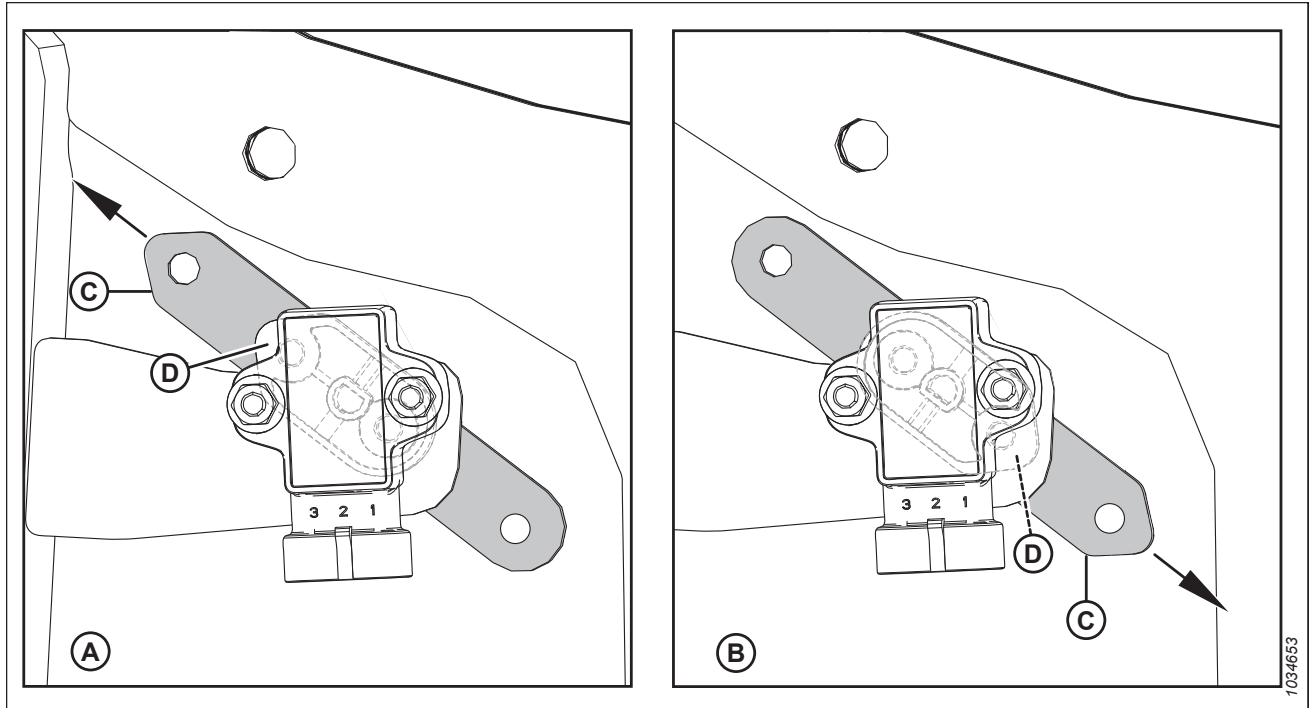

Figure 5.53: Sensor Arm/Pointer Configurations

A - Challenger®, CLAAS, Gleaner®, IDEAL™, Massey Ferguson®, and John Deere Configuration

B - Case, New Holland, and Rostselmash Configuration

C - Sensor Arm (Shown Semitransparent)

D - Sensor Pointer (Shown Under Sensor Arm)

3. Attach reel height sensor rod (A) to reel arm bracket (B) with already installed nut (C). Secure the other end of the rod to the sensor arm with nut (D). Torque nuts (C) and (D) to 8 Nm (6 lbf-ft [73 lbf-in]).

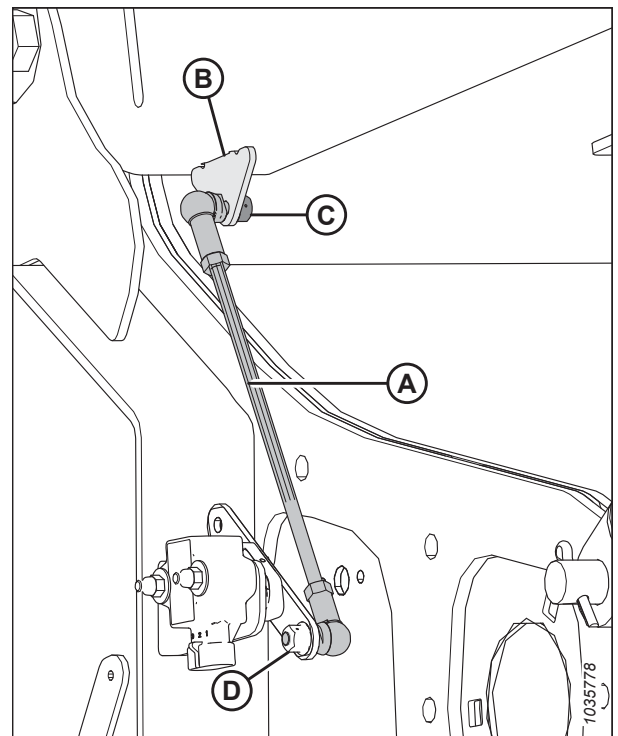

Figure 5.54: Reel Height Sensor

COMPLETING HEADER ASSEMBLY

NOTE:

Dimension (A) is set to 165 mm (6 1/2 in.), but it might need to be adjusted in [7.1 Checking and Adjusting Reel Height Sensor, page 259](#) to achieve the correct voltage range.

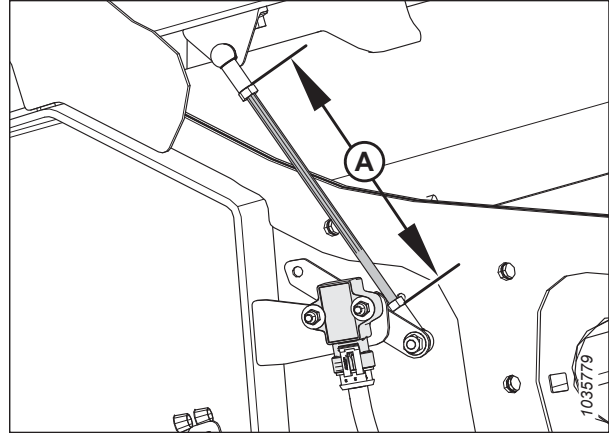

Figure 5.55: Reel Height Sensor – Right Reel Arm with Reel Down

4. Close the right header endshield. For instructions, refer to [10.4.2 Closing Header Endshields, page 523](#).

5.12 Installing Reel Fore-Aft Steel Lines (Parts Bag MD #357107)

The steel lines on one of the reel arms need to be clamped into place.

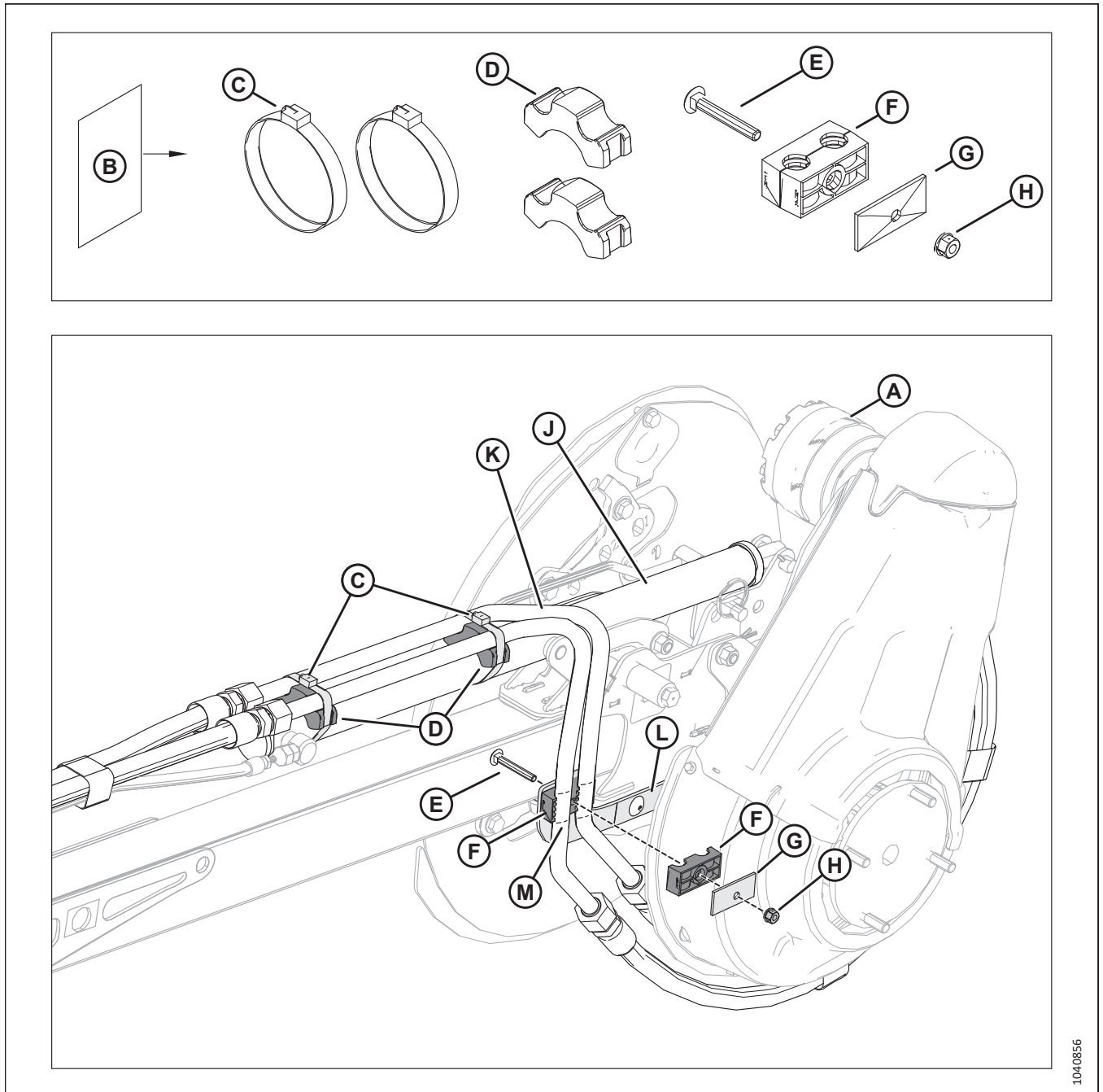

Figure 5.56: Steel Line Installation

1. Locate reel drive motor (A). Retrieve bag (B) MD #357107, which contains parts (C), (D), (E), (F), (G), and (H).

NOTE:

On headers that are 35 ft. or narrower, the bag is attached to cylinder (J).

2. Remove the foam and shipping wire from tubes (K). Place both tubes on top of cylinder (J) and against bracket (L).

COMPLETING HEADER ASSEMBLY

3. Install clamp (F) onto both lines, between markings (M). Attach the clamp to bracket (L) using bolt (E), cover (G), and M8 nut (H).
4. Tighten M8 nut (H) to 7 Nm (5 lbf·ft [62 lbf·in]).
5. Seat the steel lines in clamps (D). Secure the clamps and lines to the cylinder using gear clamps (C). Make sure the barrel end of the gear clamps is on top as shown.

5.13 Preparing Hydraulic Hoses

The hydraulic hoses on the left of the float module are temporarily secured during shipping. They will need to be rerouted.

1. On the left side of the float module, remove shipping wire (A) from the hydraulic hoses.
2. Place hose bundle (B) in bracket (C). Secure the hose bundle in the bracket by reinstalling strap (D) through bracket slot (E) and over the hose bundle.

NOTE:

Ensure that hose bundle (B) is securely strapped to bracket (C). Improper strapping can result in the hoses wearing through.

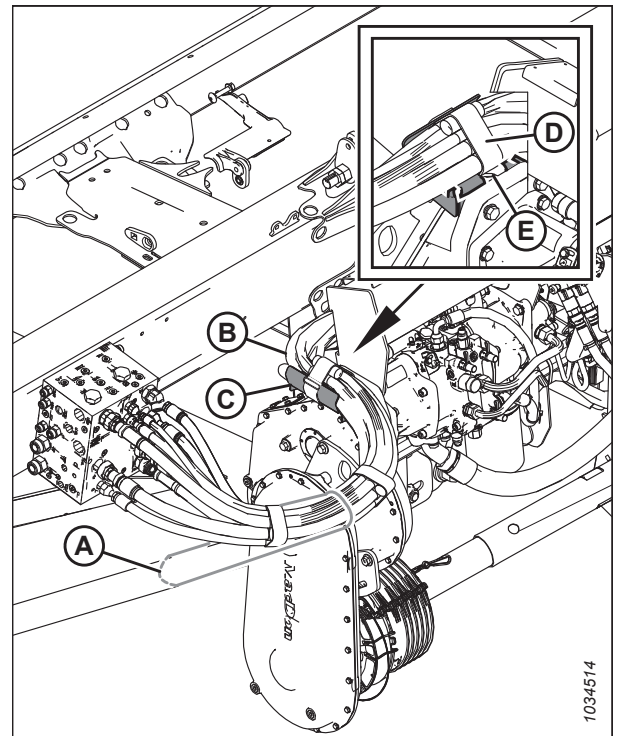

Figure 5.57: Hydraulic Hoses – Narrow Configuration

5.14 Connecting Reel to Fore-Aft Cylinders, Single-Reel Headers – D225 (Parts Bag MD #357467)

Fore-aft cylinders move the reel fore and aft on the reel arms. The hydraulic connections fore-aft cylinders on single-reel headers will need to be completed.

CAUTION

The reel fore-aft hydraulic cylinders must be connected to the reel before fore-aft shipping supports (A) are removed. Failure to do so may result in the reel sliding fully forward when the supports are removed.

CAUTION

Ensure that the header hydraulics are connected to the combine. Lift the reel to level the reel support arms; this will prevent the reel from moving when the fore-aft shipping supports are removed.

DANGER

To prevent bodily injury or death from the unexpected start-up of the machine, always stop the engine and remove the key from the ignition before making adjustments to the machine.

DANGER

Ensure that all bystanders have cleared the area.

1. Raise the reel arms until they are parallel with the ground.
2. Shut down the engine, and remove the key from the ignition.

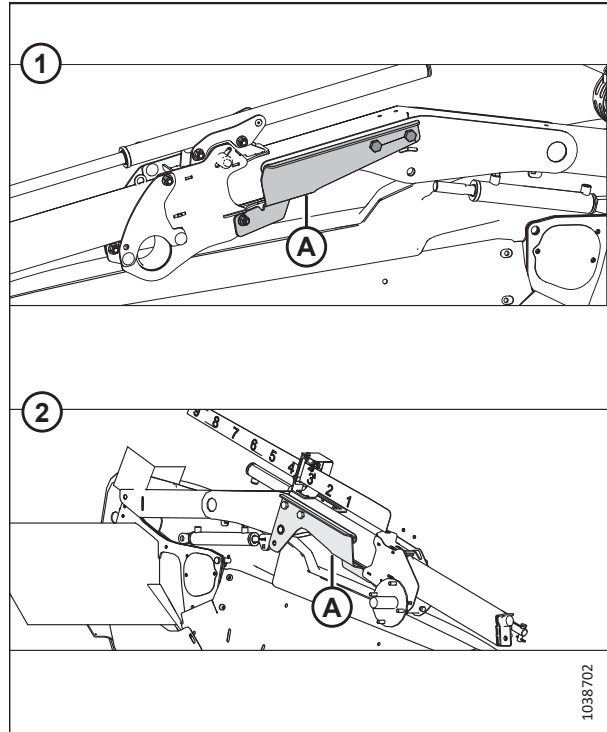

Figure 5.58: Fore-Aft Shipping Supports

1 - Right Reel Arm

2 - Left Reel Arm

COMPLETING HEADER ASSEMBLY

Preparing right reel arm

3. Retrieve parts bag (MD #357467). For a list of parts, refer to Table 5.3, page 131.

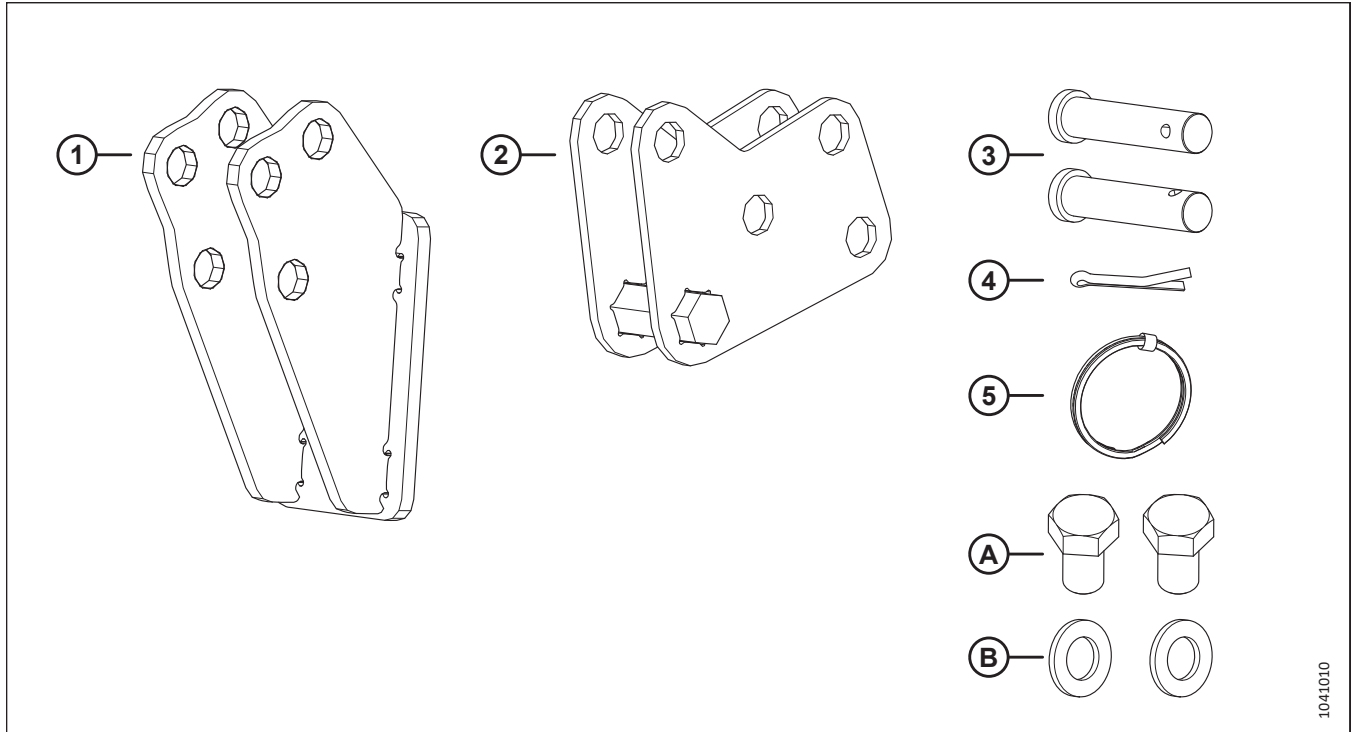

Figure 5.59: Right Reel Arm Fore-Aft Support Parts Bag MD #357467

Table 5.3 Right Reel Arm Fore-Aft Support Parts Bag MD #357467

Ref	Part Number	Description	Quantity
1	311237	SUPPORT – FRONT ANCHOR	1
2	311238	ANCHOR – FORE-AFT	1
3	18704	PIN – CLEVIS	2
4	18607	PIN – COTTER 5/32 DIA X 1.5 ZP	1
5	320207	RING – SPLIT	1
A	136143	BOLT – HEX HD TFL M16 X 2 X 30-10.9 AA1J	2
B	184717	WASHER – FLAT REG M16-200HV-AA1J	2

COMPLETING HEADER ASSEMBLY

4. Install front anchor support (A) on the end of the right reel arm using two M16 x 30 mm bolts (B) as shown. Torque the bolts to 249 Nm (184 lbf·ft).

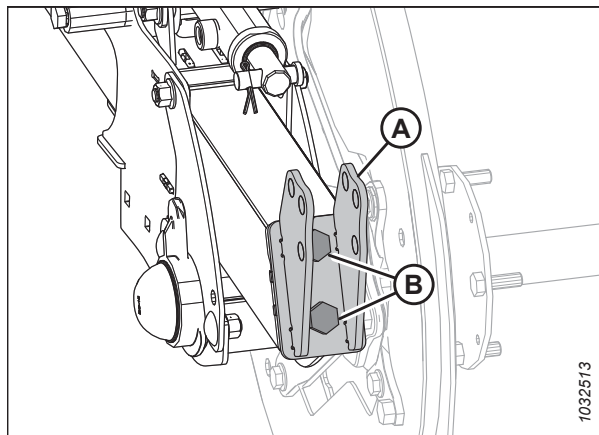

Figure 5.60: Front Anchor Support

5. Attach fore-aft anchor (A) to the front support using two clevis pins (B) and two washers.

IMPORTANT:

Ensure that anchor (A) is installed in the forward position as shown. The cylinder on the left arm is installed in the forward position from the factory; all fore-aft cylinders must be installed in the same position to prevent damage to the reel during operation.

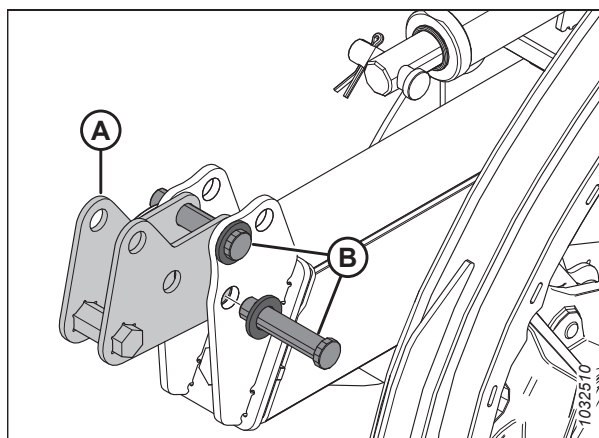

Figure 5.61: Fore-Aft Anchor

6. Secure the clevis pins with split ring (A) and cotter pin (B).

NOTE:

It is easier for the Operator to toggle between the two cylinder positions if the split ring is installed on the top clevis pin.

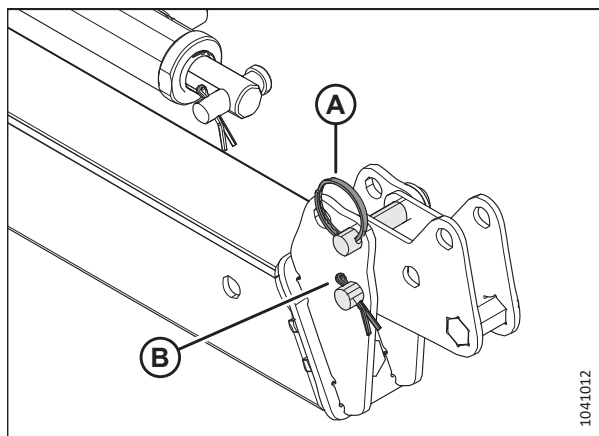

Figure 5.62: Fore-Aft Anchor

COMPLETING HEADER ASSEMBLY

Securing cylinders to reel arms

7. Remove and retain cotter pin (A) and clevis pin (B) from the left fore-aft cylinder rod. Remove the shipping wire securing the cylinder rod to the reel support.

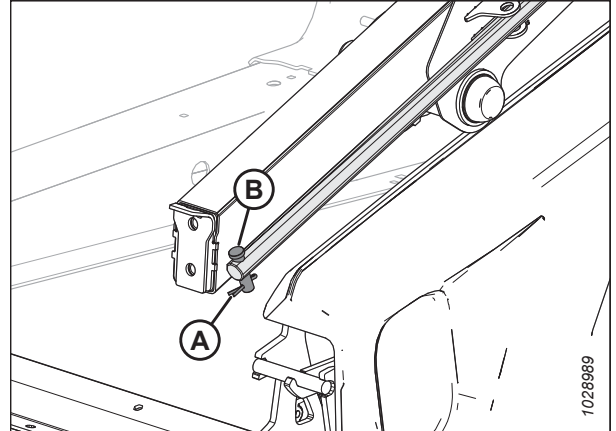

Figure 5.63: Left Reel Arm

8. Remove and retain cotter pin (A) and clevis pin (B) from the right fore-aft cylinder rod.

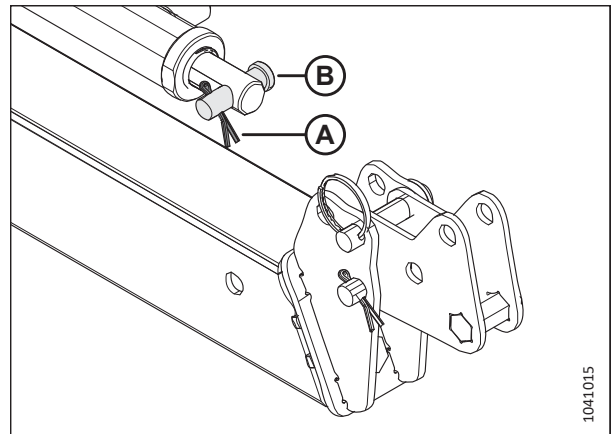

Figure 5.64: Shipping Location of Pins in Right Fore-aft Cylinder

9. Use the combine controls or move the reel by hand to align the reel arm mounting holes with the fore-aft cylinders.
10. Shut down the engine, and remove the key from the ignition.
11. On the right arm, attach fore-aft cylinder rod (A) to fore-aft anchor (B) with retained clevis pin (C) and cotter pin (D).

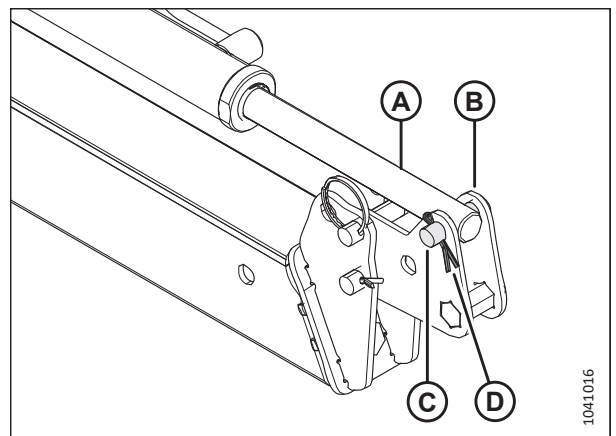

Figure 5.65: Cylinder Secured to Right Reel Arm

COMPLETING HEADER ASSEMBLY

12. On the left arm, attach fore-aft cylinder rod (A) to reel end support (B) with clevis pin and cotter pin (C).

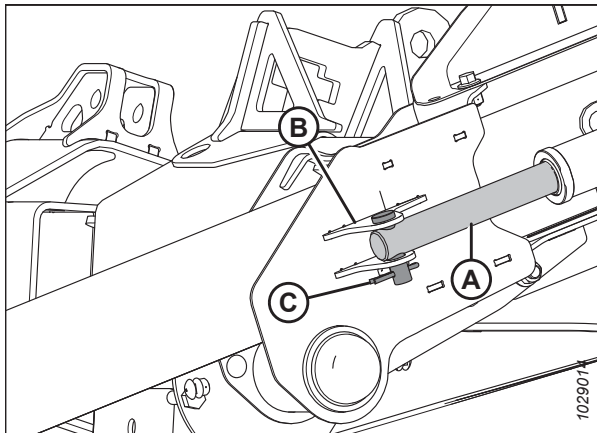

Figure 5.66: Cylinder Secured to Left Reel Arm

13. On the left reel arm, remove hardware (A) and shipping support (B).

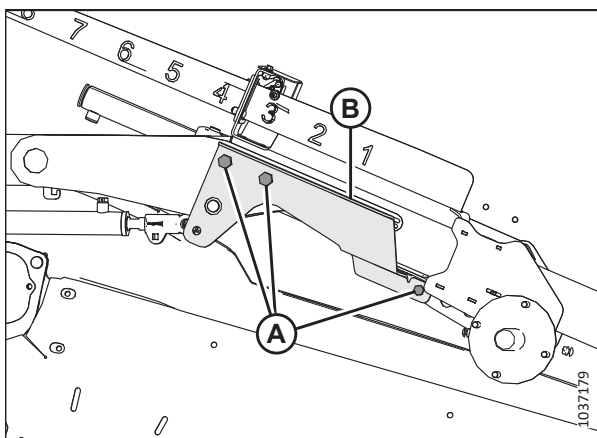

Figure 5.67: Left Reel Arm Shipping Support

14. On the right reel arm, remove hardware (A) and shipping support (B).
15. Phase the fore-aft cylinders by adjusting the reel fully forward and fully rearward two or three times.
16. Shut down the engine, and remove the key from the ignition.

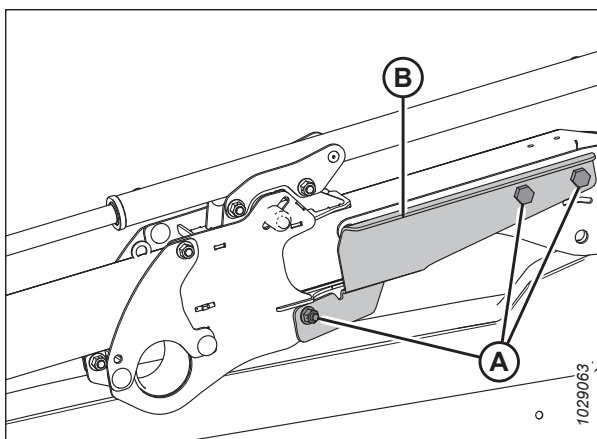

Figure 5.68: Right Reel Arm Shipping Support

COMPLETING HEADER ASSEMBLY

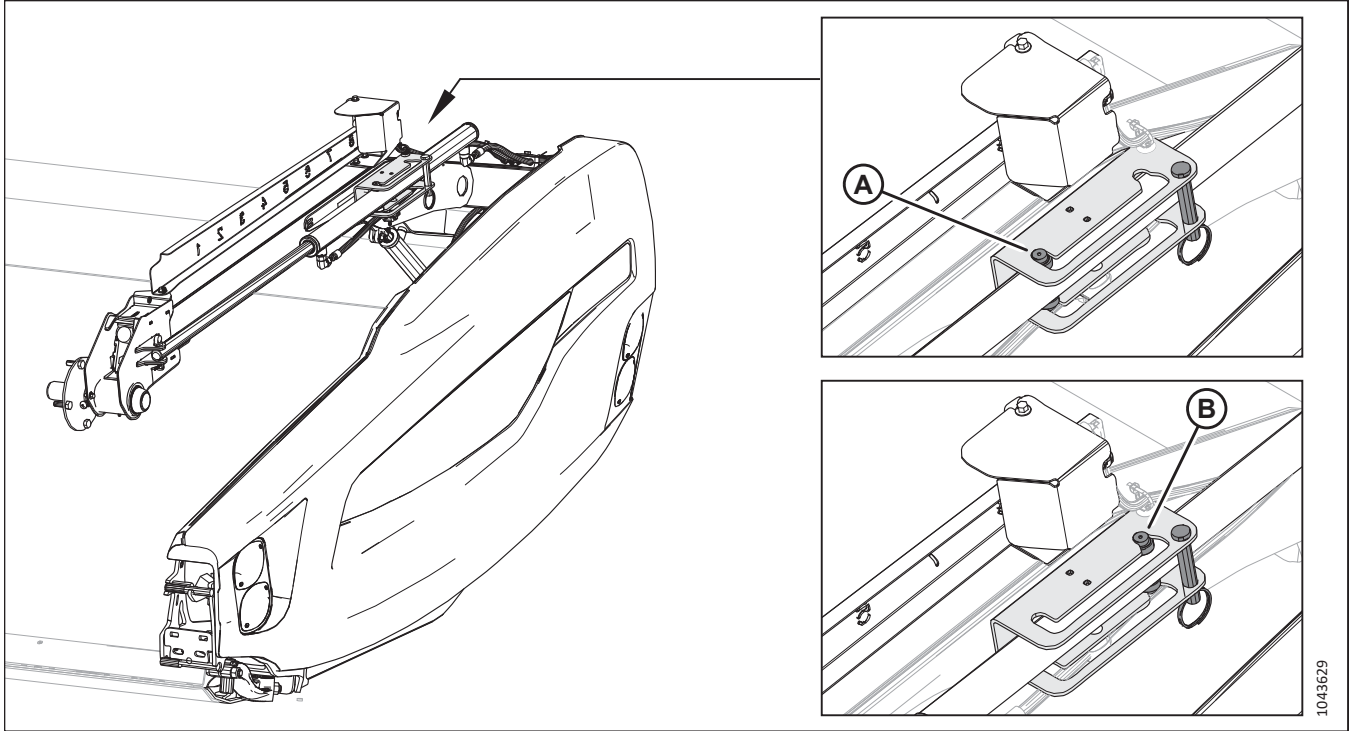

Figure 5.69: Left Arm Cylinder

NOTE:

From the factory, the reel is set in the fore position (A). This allows the reel to reach lodged crop ahead of the cutterbar to carry it onto the drapers. For delicate and shatter-prone crops, it may be necessary to reposition the fore-aft cylinders to the aft position (B). Doing so allows the reel to be positioned over the drapers, which prevents seed loss. For further instructions, refer to the header operator's manual.

NOTE:

To install vertical knives, the fore-aft cylinders will need to be in the aft position. For further instructions, refer to the header operator's manual.

5.15 Connecting Reel to Fore-Aft Cylinders – Double-Reel Headers D230 and D235 (Parts Bag MD #347580)

The fore-aft cylinders move the reel fore and aft on the reel arms. The cylinders on the headers will need to be installed.

CAUTION

The reel fore-aft hydraulic cylinders must be connected to the reel before fore-aft shipping supports (A) are removed. Failure to do so may result in the reel sliding fully forward when the supports are removed.

CAUTION

Ensure that the header hydraulics are connected to the combine. Lift the reel to level the reel support arms; this will prevent the reel from moving when the fore-aft shipping supports are removed.

DANGER

To prevent injury or death from the unexpected start-up of the machine, always stop the engine and remove the key from the ignition before leaving the operator's seat for any reason.

DANGER

Ensure that all bystanders have cleared the area.

1. Raise the reel arms until they are parallel with the ground.
2. Shut down the engine, and remove the key from the ignition.

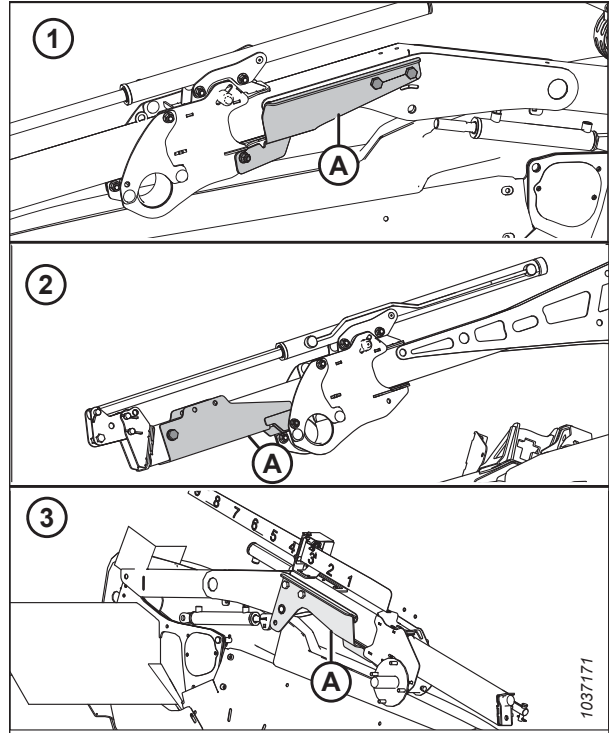

Figure 5.70: Fore-Aft Shipping Supports

1 - Outer Right Reel Arm

2 - Center Reel Arm

3 - Outer Left Reel Arm

COMPLETING HEADER ASSEMBLY

3. Retrieve parts bag MD #347580. For a list of parts, refer to Table 5.4, page 137.

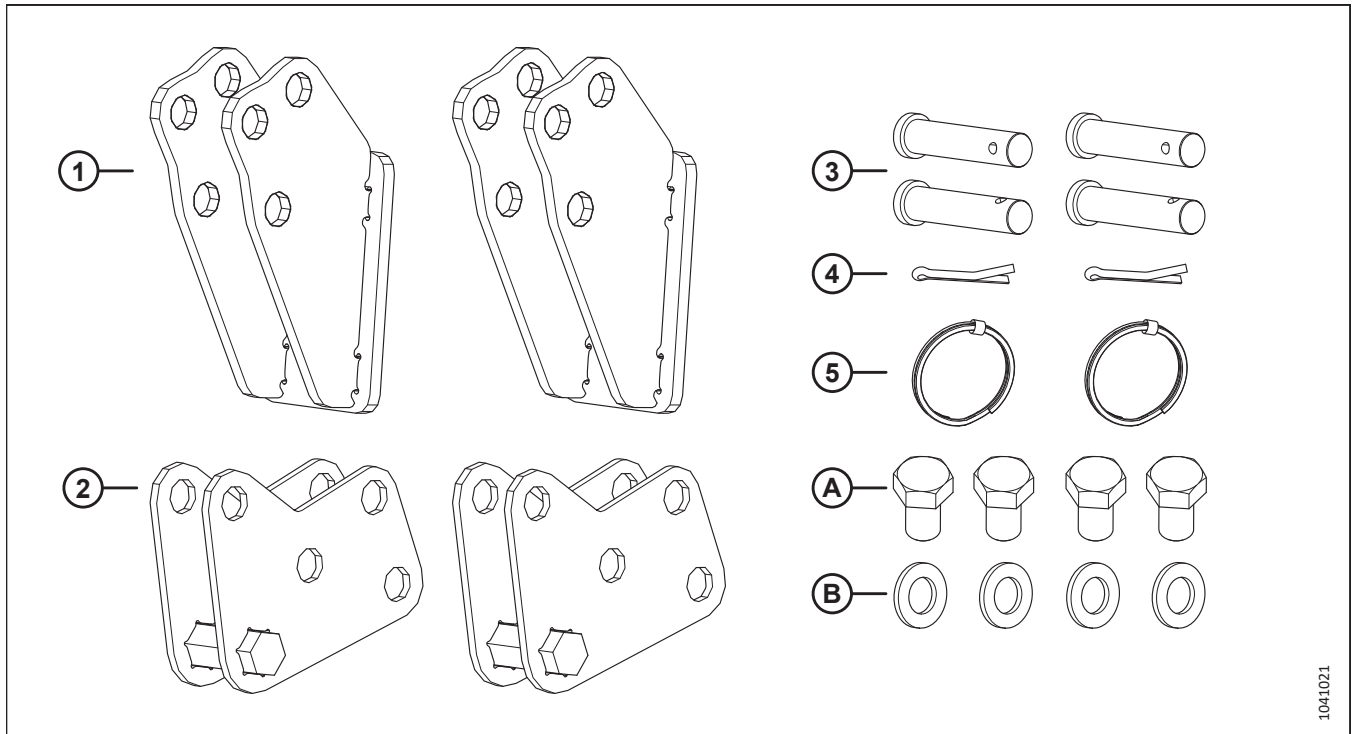

Figure 5.71: Fore-Aft Support Parts Bag MD #347580 for Center Arm and Right Arm

Table 5.4 Fore-Aft Support Parts Bag MD #347580 for Center Arm and Right Arm

Ref	Part Number	Description	Quantity
1	311237	SUPPORT – FRONT ANCHOR	2
2	311238	ANCHOR – FORE-AFT	2
3	18704	PIN – CLEVIS	4
4	18607	PIN – COTTER 5/32 DIA X 1.5 ZP	2
5	320207	RING – SPLIT	2
A	136143	BOLT – HEX HD TFL M16 X 2 X 30-10.9 AA1J	4
B	184717	WASHER – FLAT REG M16-200HV-AA1J	4

COMPLETING HEADER ASSEMBLY

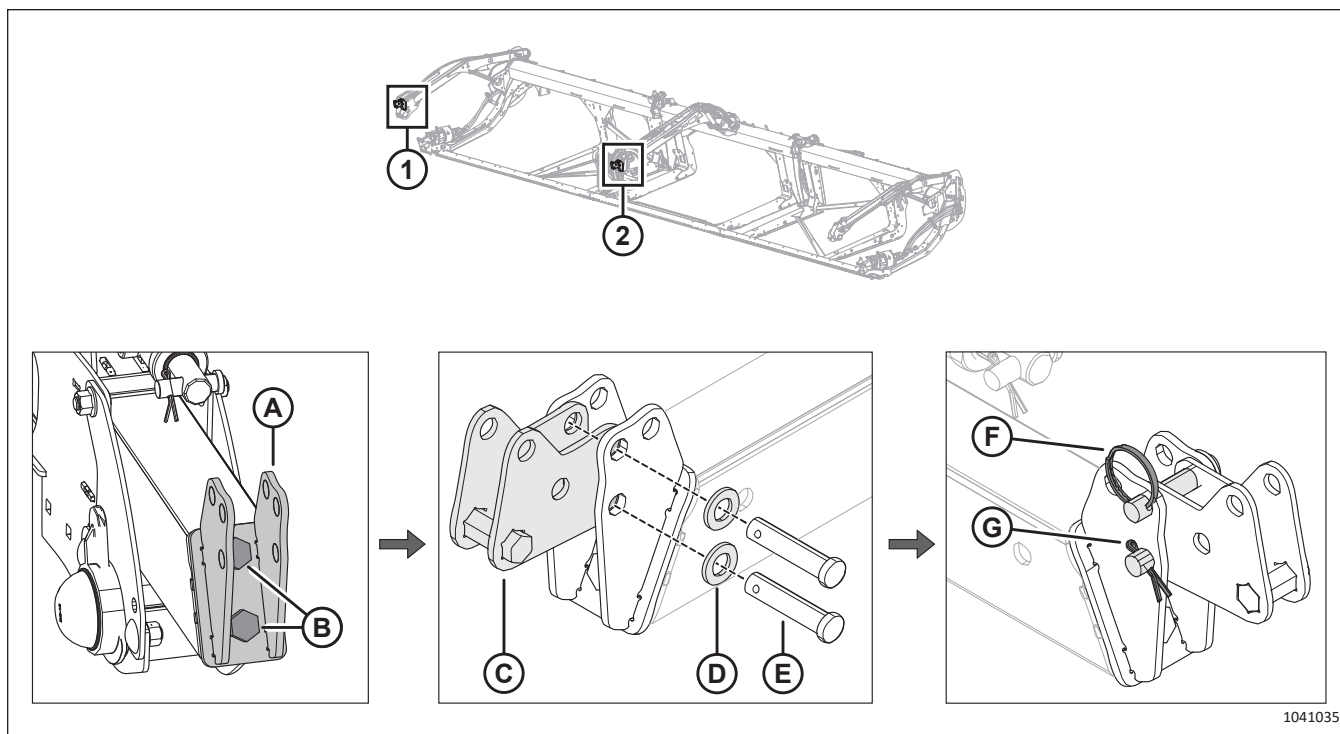

Figure 5.72: Fore-Aft Support Locations

4. Install the contents of parts bag MD #347580 on right arm (1) and center arm (2):
 - a. Install front support (A) using two M16 bolts (B). Tighten the bolts to 249 Nm (184 lbf·ft).
 - b. Attach fore-aft anchor (C) to the front support using two washers (D) and two clevis pins (E).

IMPORTANT:

Ensure that anchor (C) is installed in the forward position as shown. The cylinder on the left arm is installed in the forward position from the factory. All fore-aft cylinders must be installed in the same position to prevent damage to the reel during operation.

- c. Secure the top clevis pin with split ring (F). Secure the bottom clevis pin with cotter pin (G).

NOTE:

It is easier for the Operator to toggle between the two cylinder position if the split ring is installed on the top clevis pin.

COMPLETING HEADER ASSEMBLY

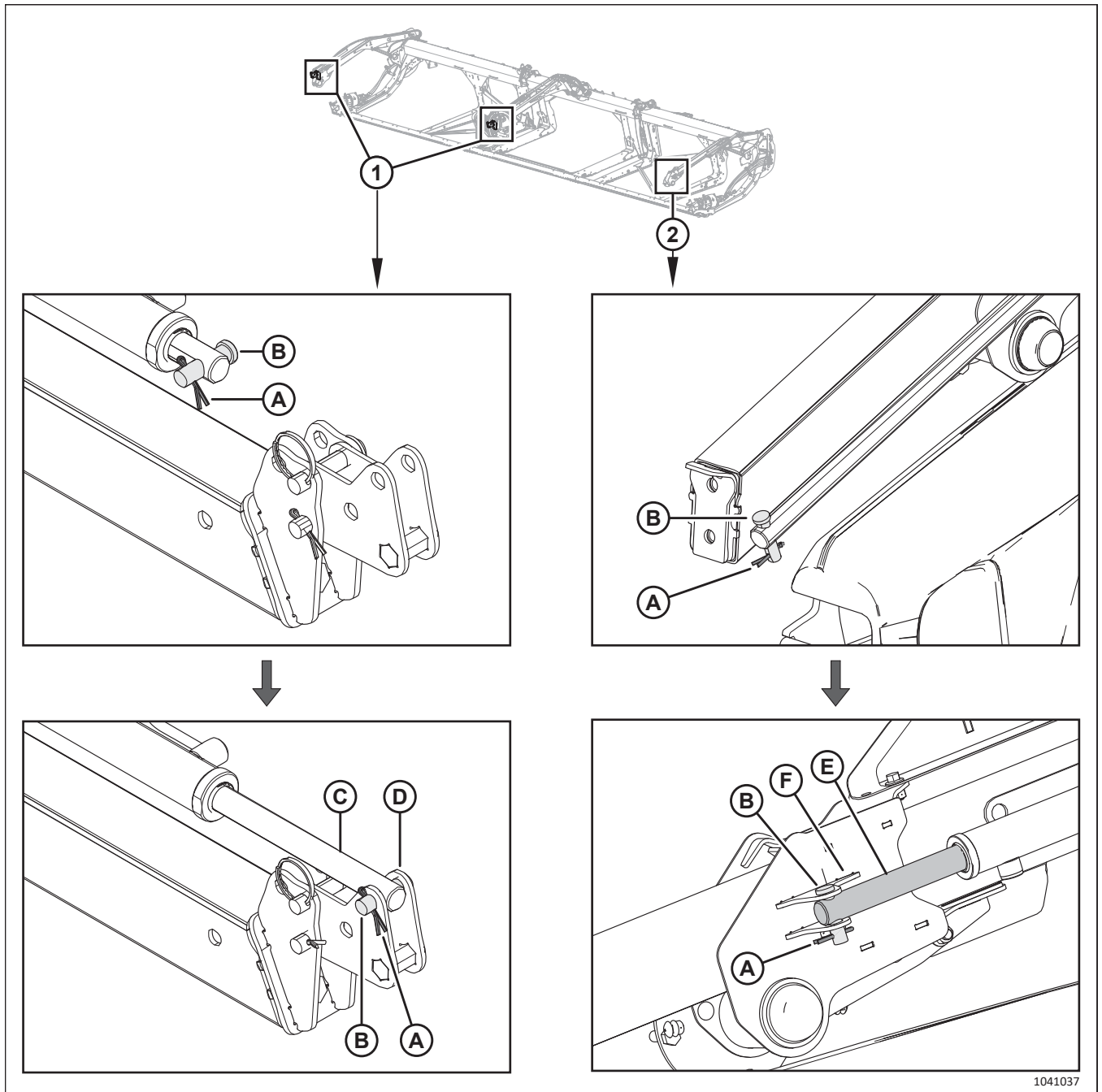

Figure 5.73: Double-Reel Fore-Aft Cylinder Rods

5. Remove and retain cotter pin (A) and clevis pin (B) from all three fore-aft cylinder rods.
6. Use the combine controls or move the reel by hand to align the reel arm mounting holes with the fore-aft cylinders.
7. Shut down the engine, and remove the key from the ignition.
8. On right and center reel arms (1), secure cylinder rod (C) to anchor (D) using clevis pin (B) and cotter pin (A).
9. On left reel arm (2), secure cylinder rod (E) to support (F) using clevis pin (B) and cotter pin (A).

COMPLETING HEADER ASSEMBLY

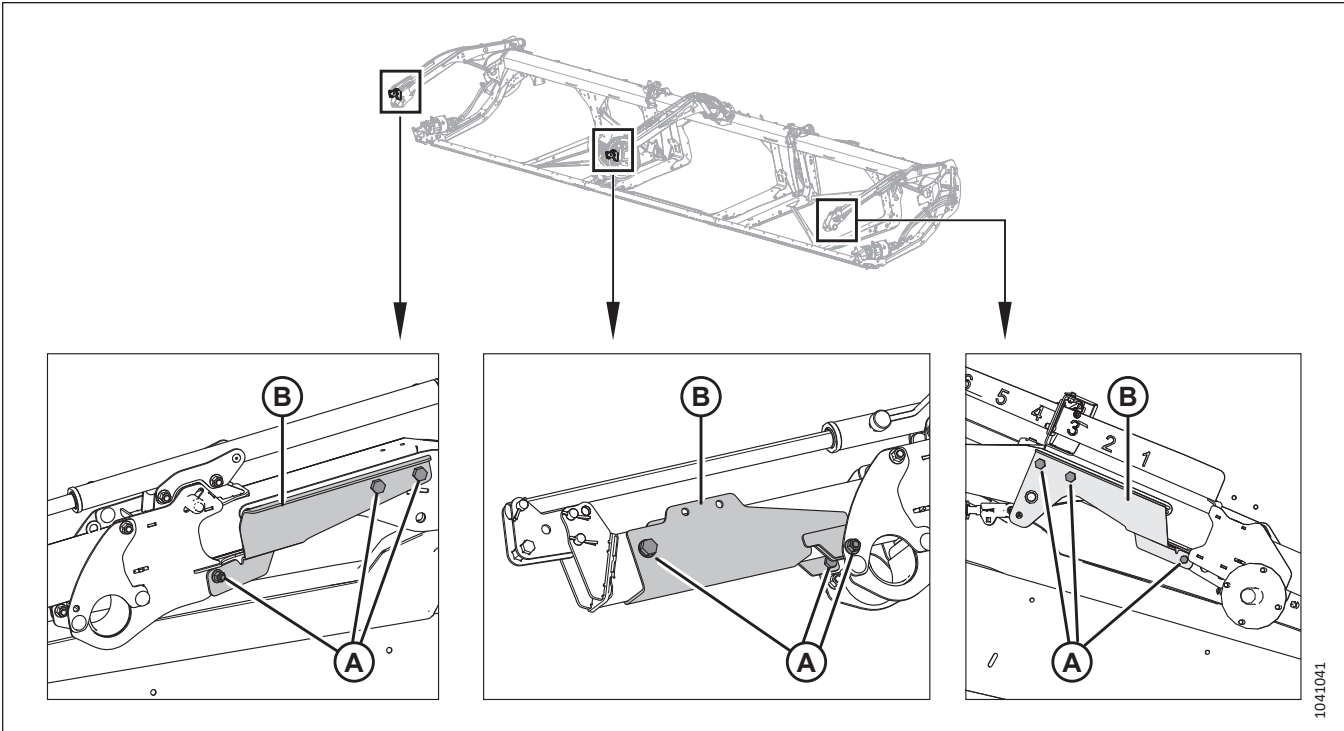

Figure 5.74: Shipping Supports

10. Remove hardware (A) from all three shipping supports (B). Discard these parts.
11. Phase the fore-aft cylinders by adjusting the reel fully forward and fully rearward two or three times.
12. Shut down the engine, and remove the key from the ignition.

COMPLETING HEADER ASSEMBLY

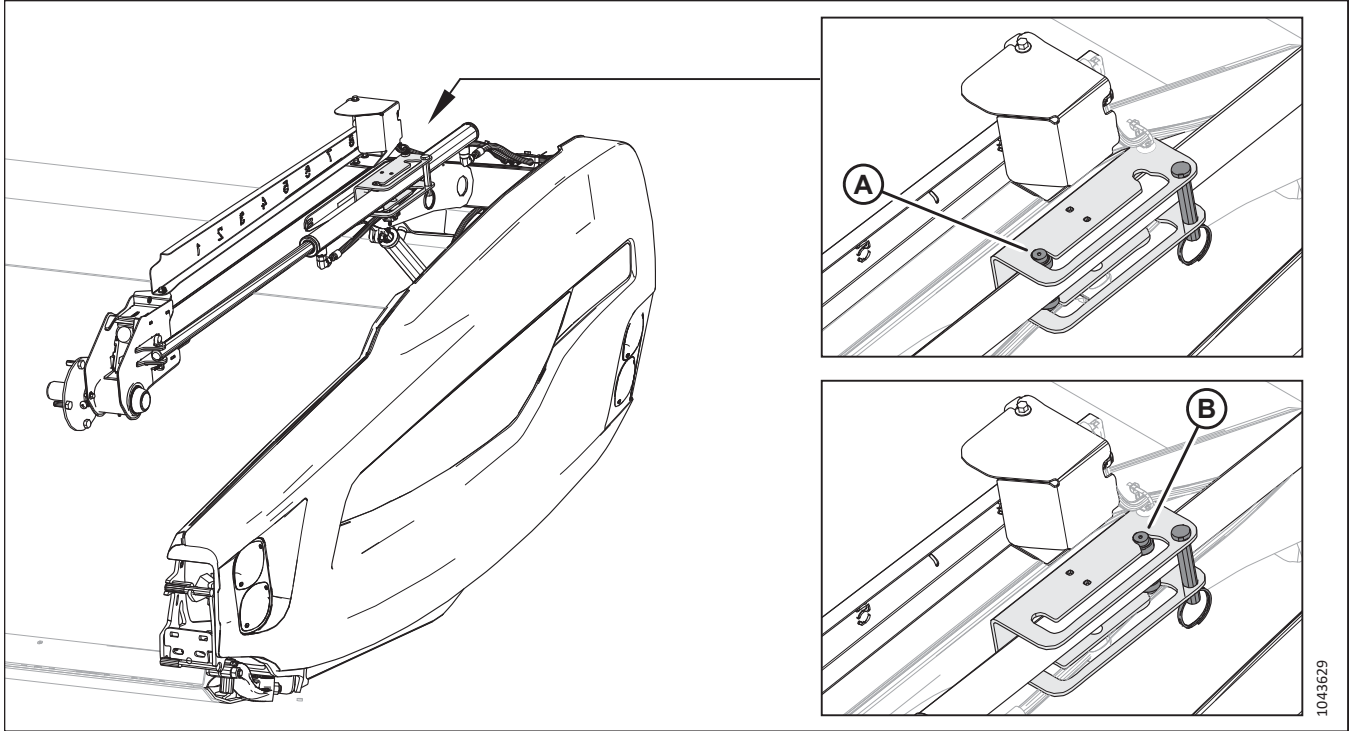

Figure 5.75: Left Arm Cylinder

NOTE:

From the factory, the reel is set in the fore position (A). This allows the reel to reach lodged crop ahead of the cutterbar to carry it onto the drapers. For delicate and shatter-prone crops, it may be necessary to reposition the fore-aft cylinders to the aft position (B). Doing so allows the reel to be positioned over the drapers, which prevents seed loss. For further instructions, refer to the header operator's manual.

NOTE:

To install vertical knives, the fore-aft cylinders will need to be in the aft position. For further instructions, refer to the header operator's manual.

5.16 Installing Reel Fore-Aft Hose Clamp – D230 and D235

A hose clamp for the reel fore-aft hoses must be installed at the center reel arm.

DANGER

To prevent bodily injury or death from the unexpected start-up of the machine, always stop the engine and remove the key from the ignition before making adjustments to the machine.

DANGER

Ensure that all bystanders have cleared the area.

1. Adjust the reel fully forward.
2. Shut down the engine, and remove the key from the ignition.
3. Reinstall the fore-aft hose clamp at location (A) as follows:
 - a. Discard the nut installed on the bottom of the clamp.
 - b. Align the bottom of the clamp with the mark on the hoses.
 - c. Ensure that there is a loop in the hose bundle to allow the reel to move forward.
 - d. Secure the clamp by installing the clamp bolt into the reel arm.

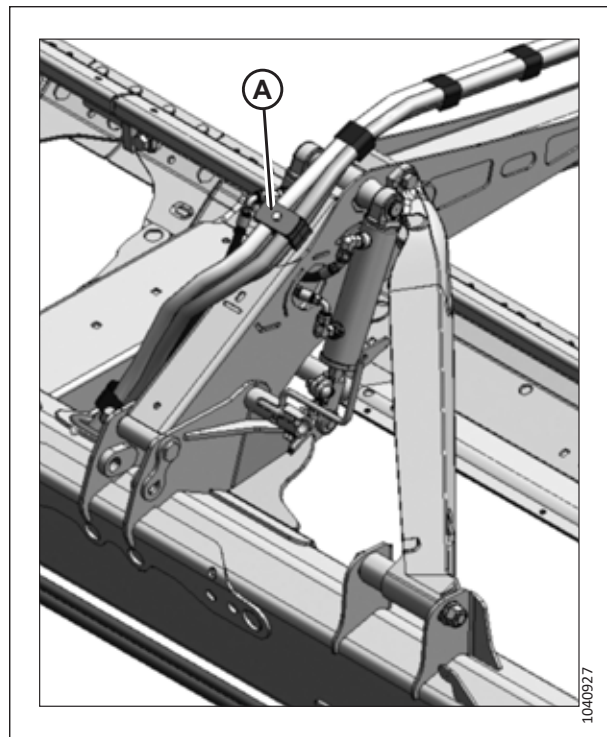

Figure 5.76: Reel Arm Fore-Aft Hose Clamp – Double-Reel

5.17 Installing Tine Tubes and Cam Control Linkages

These procedures apply to headers with one-piece frames, as opposed to wide headers shipped with the frame split on one end.

CAUTION

Wear gloves to protect yourself from cuts and scrapes while working on the reel.

5.17.1 Installing Tine Tube onto Reel – D225 (Parts Bag MD #357394)

One tine tube has been removed for shipping purposes. The tine tube must be installed for the reel to operate properly.

1. Retrieve parts bag MD #357394. For a list of parts, refer to Table 5.5, page 143.

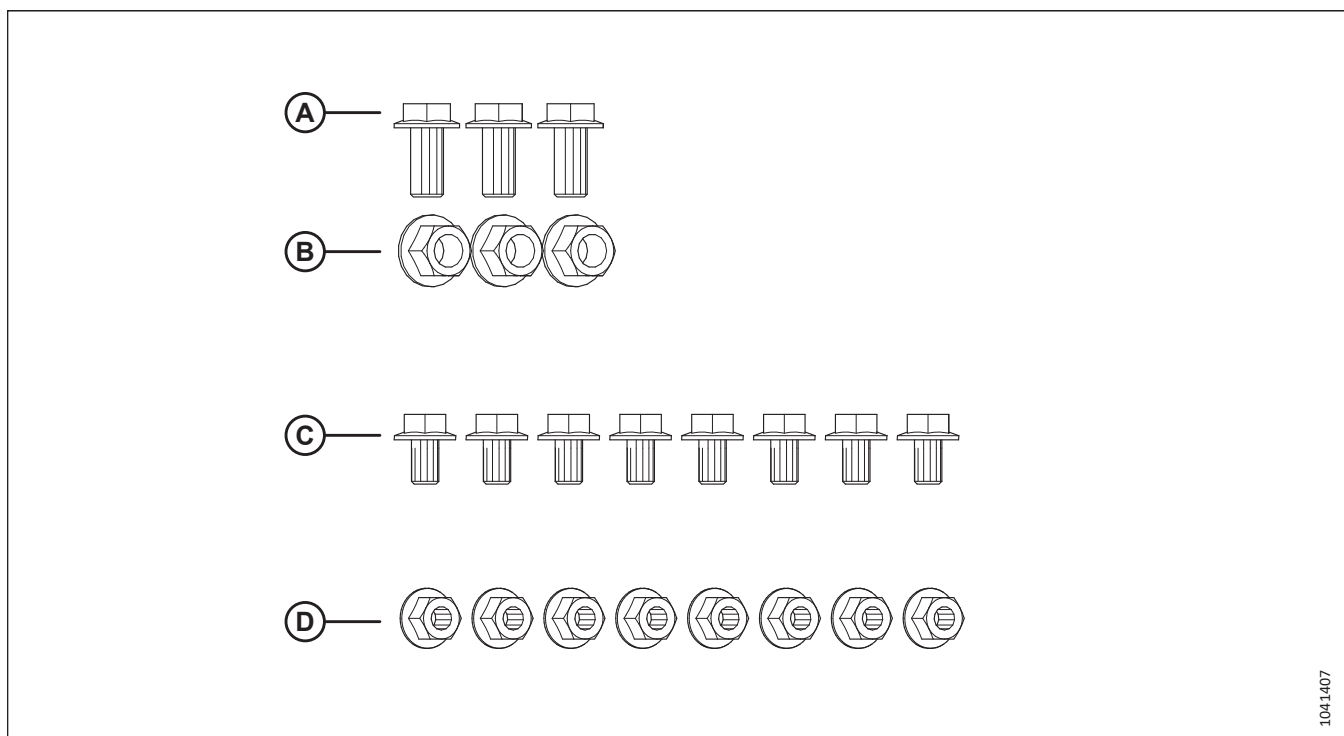
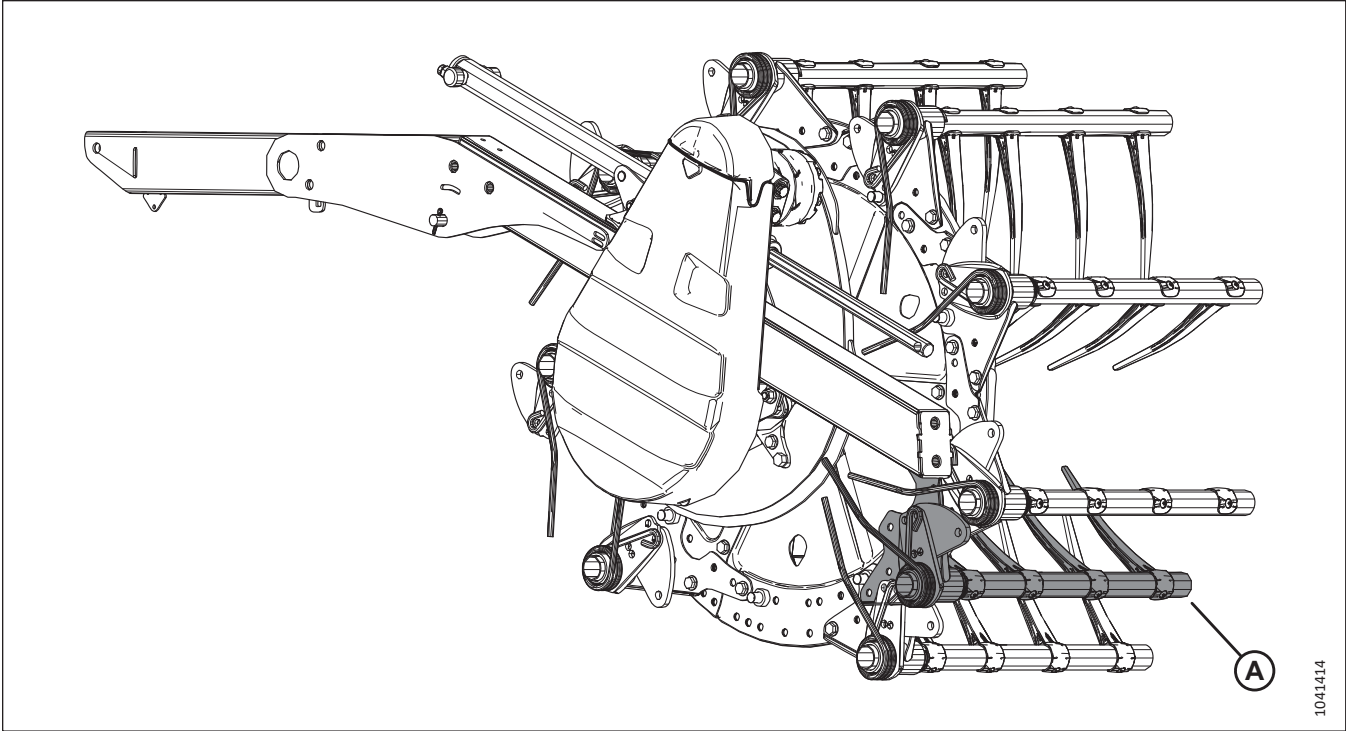

Figure 5.77: Parts Bag MD #357394

Table 5.5 Parts Bag MD #357394

Ref	Part Number	Description	Quantity
A	320175	BOLT – HEX FLG HD TFL M12 X 1.75 X 25 - SPCL - 8.8 - ZINC	3
B	136431	NUT – HEX FLG CTR LOC M12 X 1.75-10	3
C	136151	BOLT – HEX FLG HD TFL M10 X 1.5 X 16 - 8.8 - AA1J	8
D	135799	NUT – HEX FLG CTR LOC M10 X 1.5 -10	8

COMPLETING HEADER ASSEMBLY



1041414

Figure 5.78: Tine Tube in Shipping Position

2. Remove the detached tine tube (A) from the reel.

COMPLETING HEADER ASSEMBLY

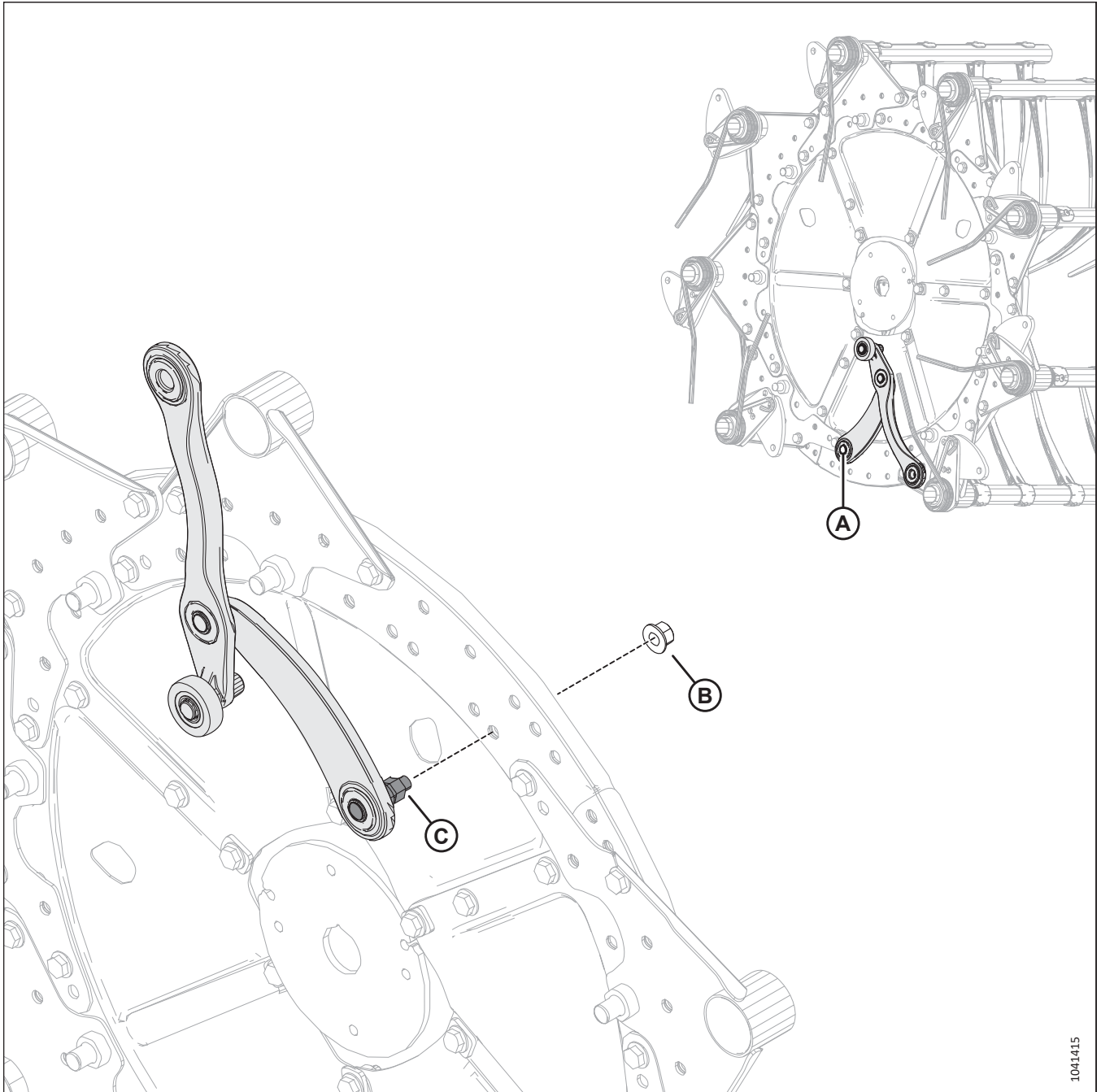

Figure 5.79: Cam Linkage Associated with Removed Tine Tube

3. Locate the one cam linkage (A) attached to the disc where there is no tine tube installed.
4. Remove and retain M12 nut (B) from cam linkage stud (C).

NOTE:

The M12 nut is the same as the M12 nuts supplied in the parts bag.

5. Pull the stud end of the cam linkage out of the disc.

COMPLETING HEADER ASSEMBLY

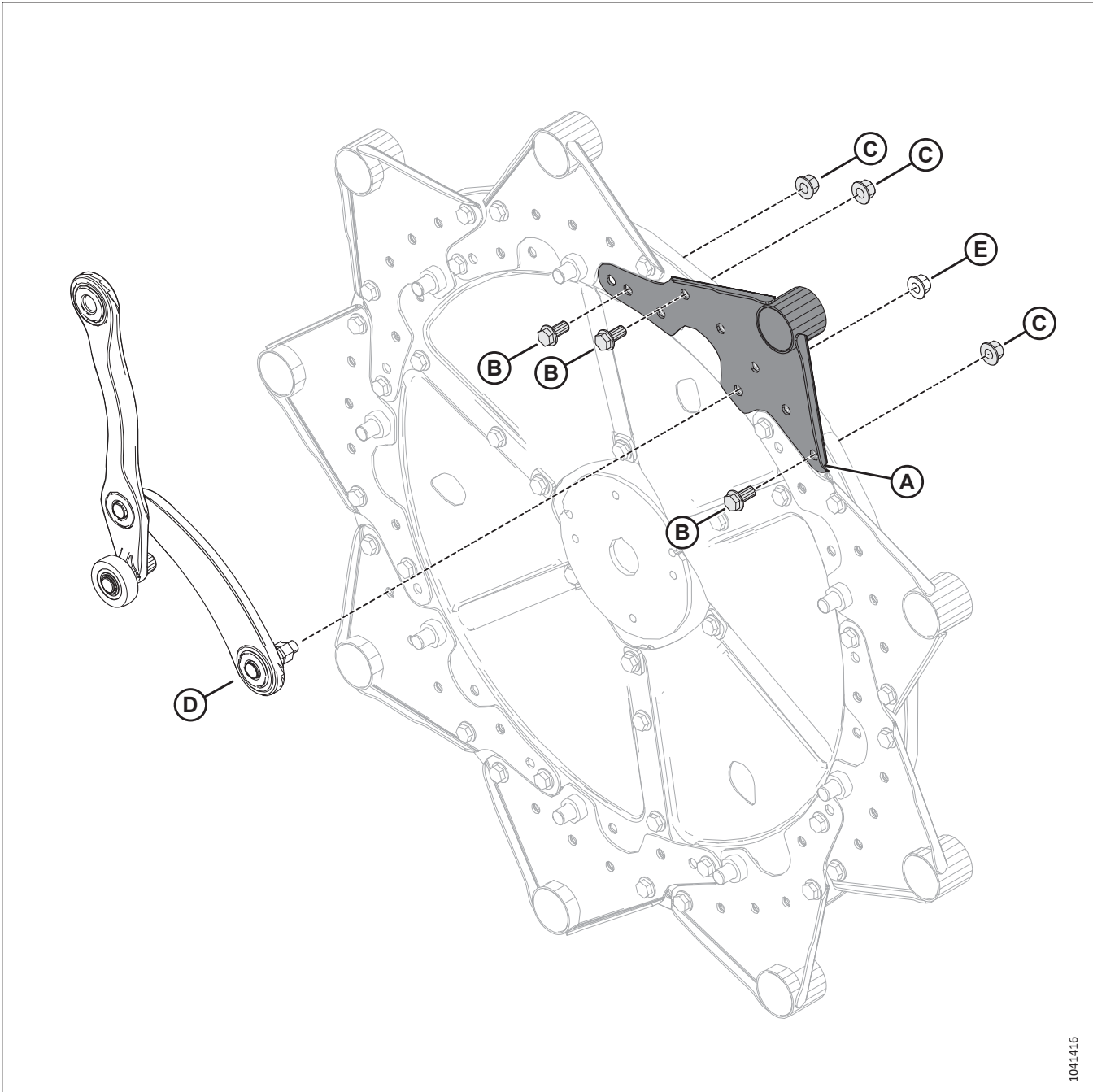

Figure 5.80: Tine Tube and Cam Linkage Installation on Cam End Disc

6. Attach tine tube (A) to the disc using three M12 bolts (B), and nuts (C).
7. Insert cam linkage stud (D) through the tine tube and secure with M12 nut (E).

COMPLETING HEADER ASSEMBLY

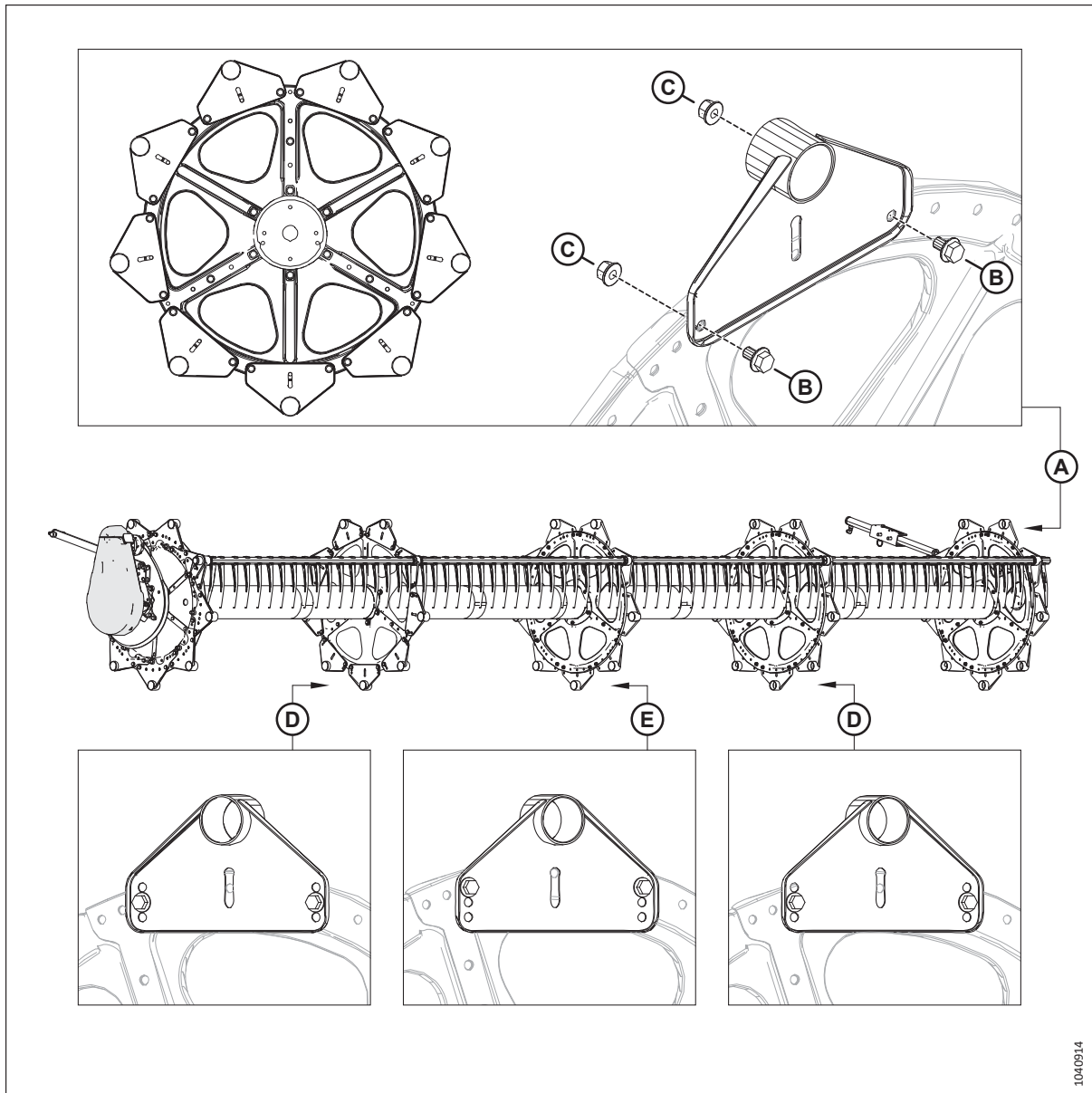

Figure 5.81: Tine Tube Installation on Mid and Tail End Discs

8. On tail end disc (A), attach the tine tube using two M10 bolts (B) and nuts (C).
9. On mid discs (D) and (E), align the tine tube mounting holes as shown, and attach it using two M10 bolts and nuts.

IMPORTANT:

Mounting the tine tubes onto the mid-discs according to specification helps maintain an even and correct clearance between the fingers and cutterbar.

10. Starting on the right of the reel and working toward the left, tighten the mounting nuts:
 - Tighten all nuts on a disc before proceeding to the next disc.
 - Tighten the M12 nuts on the cam end disc to 68.5 Nm (51 lbf·ft).
 - Tighten the M10 nuts on the remaining discs to 39 Nm (29 lbf·ft).
 - Mark tightened nuts with a paint marker.

5.17.2 Attaching Cam Control Linkages to Tine Tubes – D225 (Parts Bag MD #357743)

Seven of the nine cam linkages need to be attached to the tine tube cranks.

1. Retrieve parts bag MD #357743. This bag contains:

- Seven M16 x 30 mm bolts (A)
- Seven shims (B)

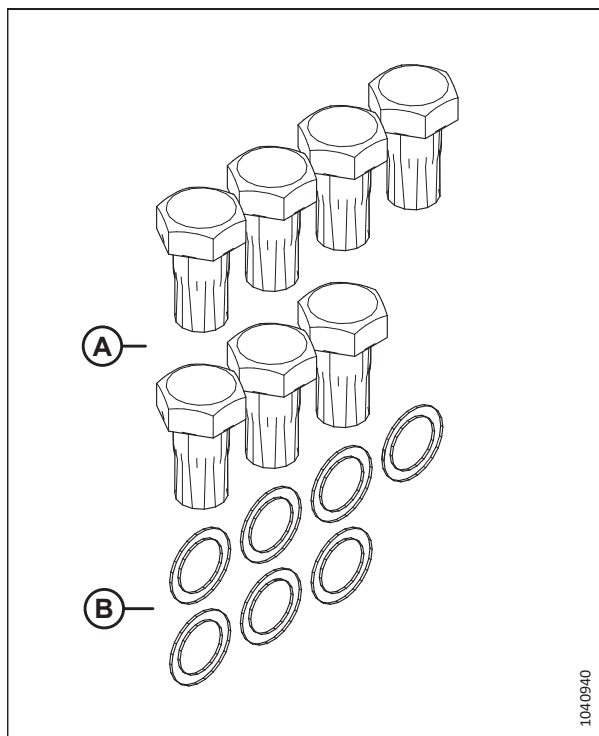

Figure 5.82: Parts Bag MD #357743

2. Install M16 bolt (A) in link (C), and position shim (B) on bolt so that shim is between link (C) and tine bar crank (D).

NOTE:

Bolts are precoated with threadlocker so no further locking method is required.

3. Realign link (C) and tine bar crank (D), and thread in bolt (A).
4. Torque bolt (A) to 163 Nm (120 lbf·ft).
5. Repeat this procedure until all seven disconnected cam linkages are re-attached. The reel has a total of nine cam linkages.

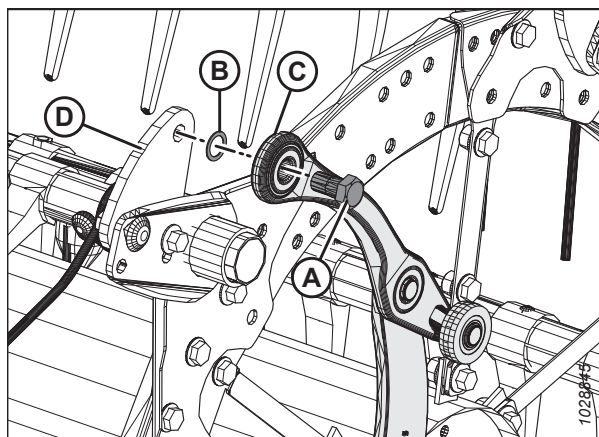

Figure 5.83: Cam Link

5.17.3 Connecting Cam Control Linkages to Tine Tube Cranks – D230 and D235 (Parts Bag MD #347627)

Four of the six cam linkages on each reel need to be reattached to the tine tube cranks.

1. Retrieve parts bag MD #347627. This bag contains:

- Eight M16 x 30 mm bolts (A)
- Eight shims (B)

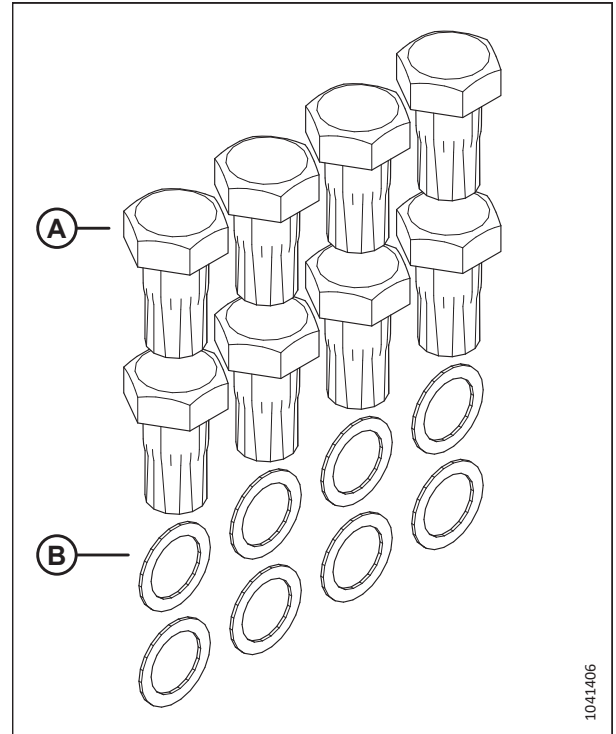

Figure 5.84: Parts Bag MD #347627

2. Install M16 bolt (A) in link (C), and position shim (B) on bolt so that shim is between link (C) and tine bar crank (D).

NOTE:

Bolts are pre-coated with Loctite® so no further locking method is required.

3. Realign link (C) and tine bar crank (D), and thread in bolt (A).
4. Torque bolt (A) to 163 Nm (120 lbf-ft).
5. Repeat this procedure until all eight disconnected cam linkages (four per reel) are re-attached. Each reel has six cam linkages.

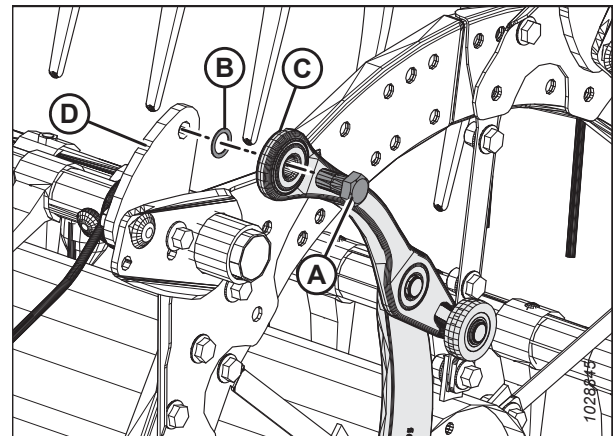

Figure 5.85: Cam Link

5.18 Installing Single-Reel Endshields, Nine-Bat – D225 (Parts Bag MD #368328)

The reel endshields on single-reel headers have been removed for shipping purposes. The reel endshields will need to be unpacked and installed on the header.

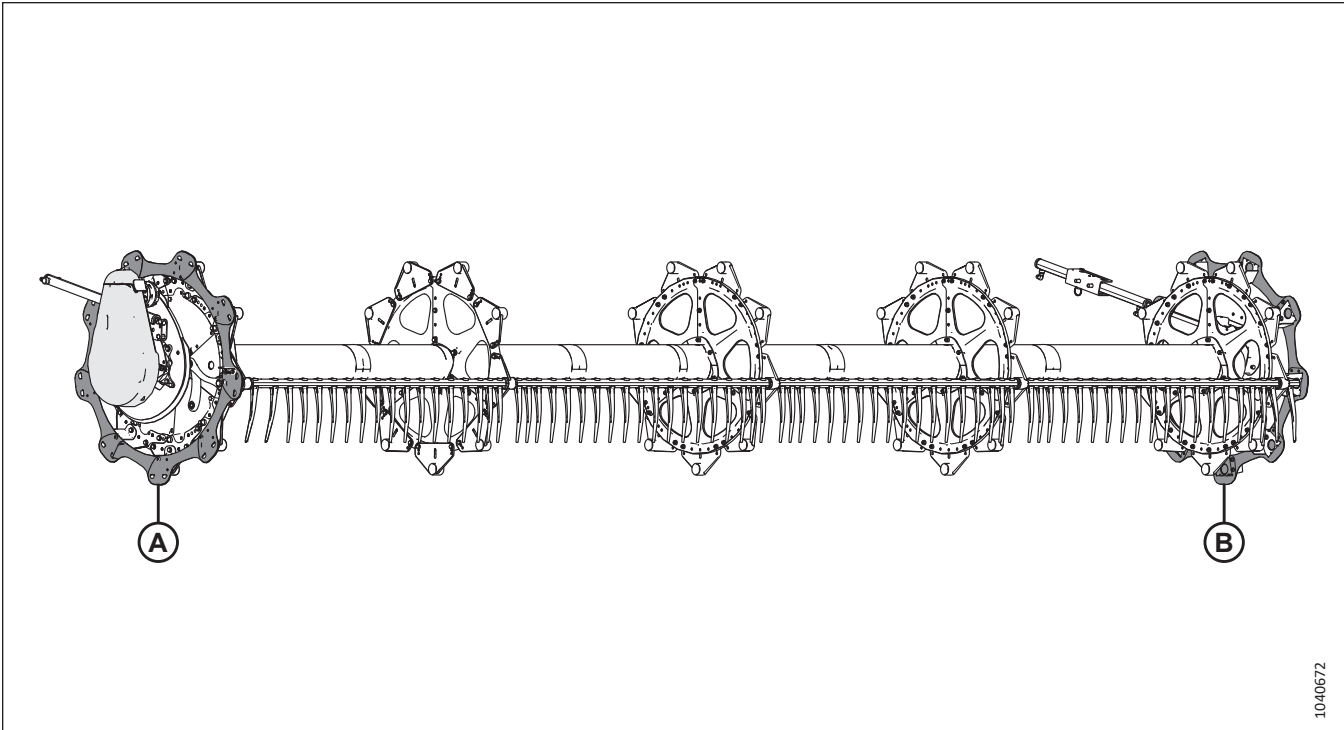

Figure 5.86: Nine-Bat Single-Reel

1. Retrieve parts bag MD #368328.

NOTE:

Parts lists and illustrations are included in the procedures referenced in the steps below.

2. Install cam-end endshields (A). For instructions, refer to [5.18.1 Installing Single-Reel Endshields at Cam End – Nine-Bat, page 151](#).
3. Install tail-end endshields (B). For instructions, refer to [5.18.2 Installing Single-Reel Endshields at Tail End – Nine-Bat, page 158](#).

5.18.1 Installing Single-Reel Endshields at Cam End – Nine-Bat

Single-reel headers have had the cam-end (right) reel endshield parts removed for shipping purposes. These parts will need to be assembled and installed on the reel.

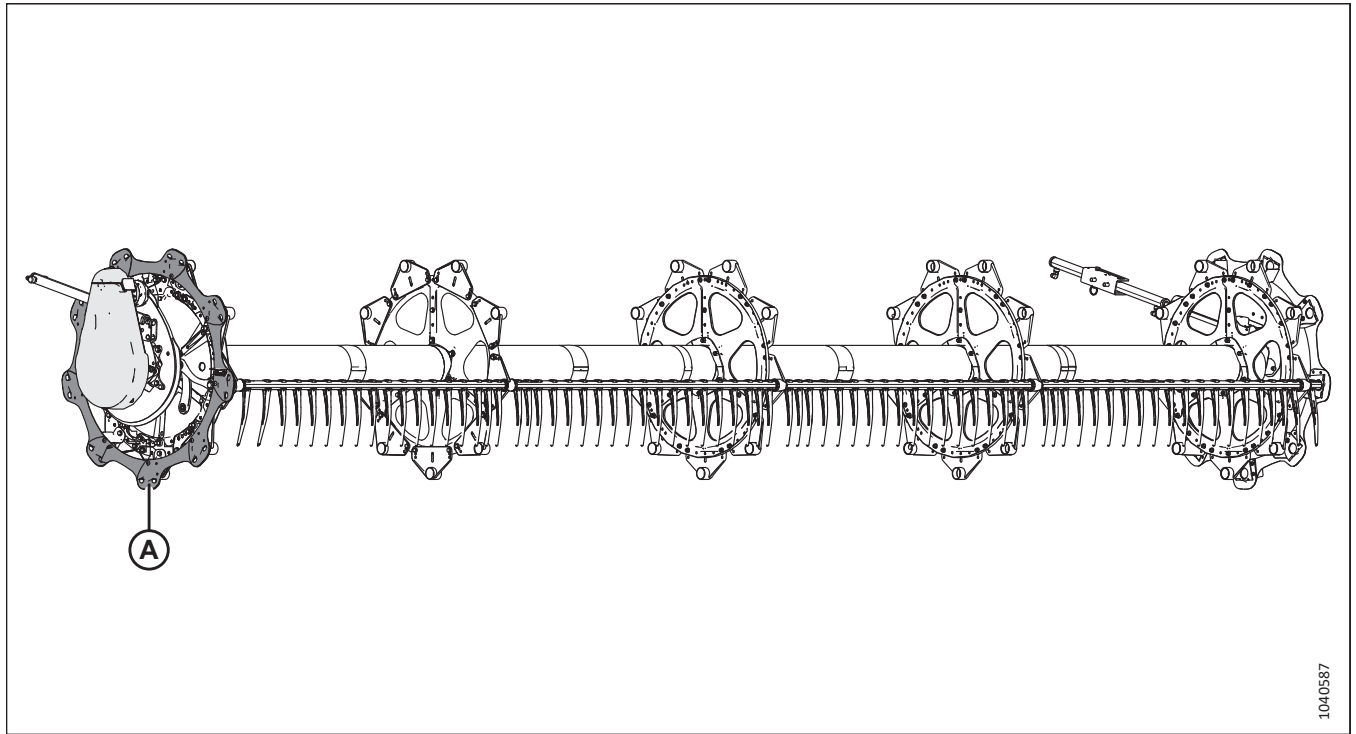

Figure 5.87: Nine-Bat Single-Reel

NOTE:

Cam-end endshields (A) are installed on the right of the reel.

1040587

COMPLETING HEADER ASSEMBLY

1. Retrieve parts bag (1) labeled with MD #368328. From that bag, retrieve the parts listed in Table 5.6, page 152.

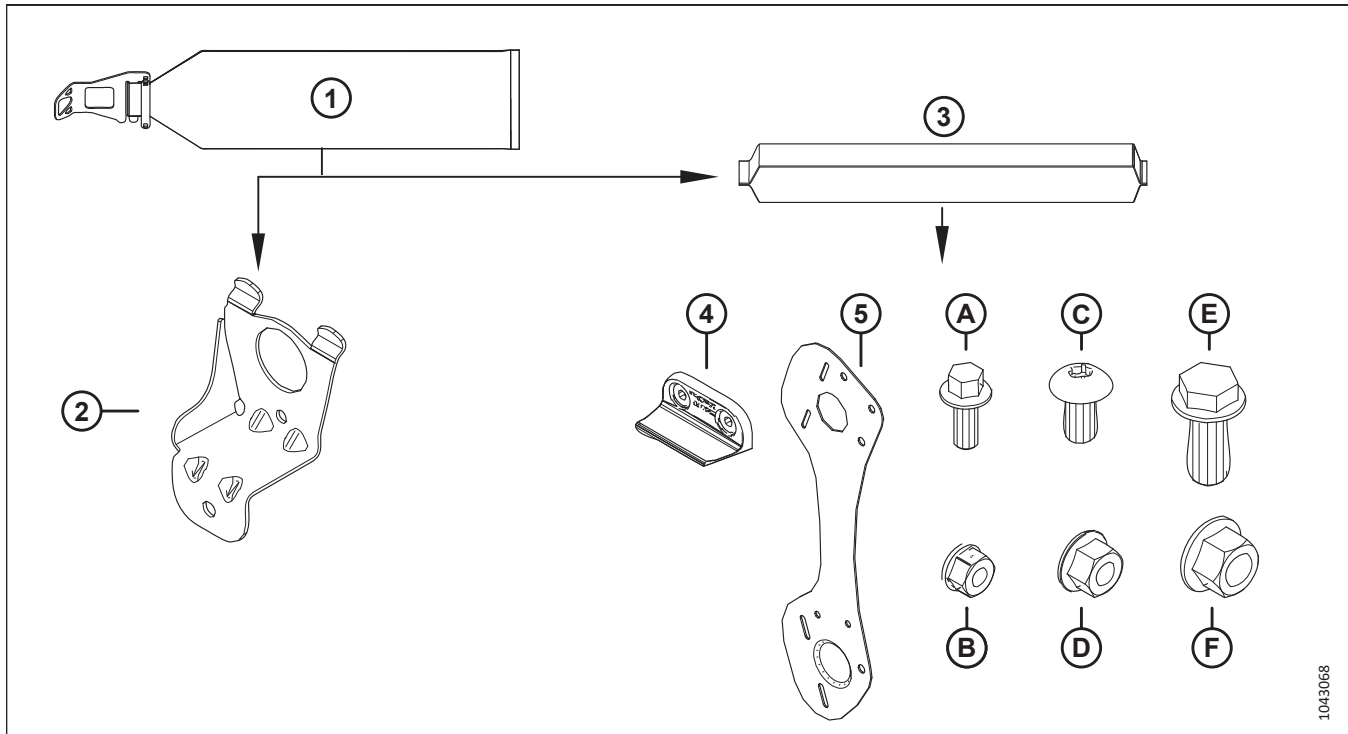

Figure 5.88: Parts to Retrieve from Nine-Bat Reel Endshields Parts Bag – MD #368328

Table 5.6 Parts to Retrieve from Nine-Bat Reel Endshields Parts Bag – MD #368328

Ref	Part Number	Description	Quantity to Retrieve
2	311964 – see note ²	SUPPORT – CAM END	9
3	368337 or “RH”	ENDSHLD BAG – 9 BAT RH OB CAM NOTE: This bag contains the parts listed below.	1
4	313035	PADDLE – REEL END; HYTREL	3
5	311863	SHIELD – OUTBOARD RH 9 BAT	9
A	136300	BOLT – HEX FLG HD TFL M8X1.25X20-8.8-AA3L	6
B	135337	NUT – HEX FLG CTR LK M8X1.25-8-AA1J	6
C	136395	SCR – TORX TRUSS HD M10X1.5X20XSPCL-8.8-A3L	9
D	135799	NUT – HEX FLG CTR LOC M10X1.5-10	9
E	320180	BOLT – HEX FLG HD M12X1.75X30-SPCL-8.8-ZINC	9
F	136431	NUT – HEX FLG CTR LOC M12X1.75-10	9

2. These parts are marked with a red cable tie to indicate that they belong with parts bag (3) (“RH”, MD #368337) which should also be marked with a red cable tie.

COMPLETING HEADER ASSEMBLY

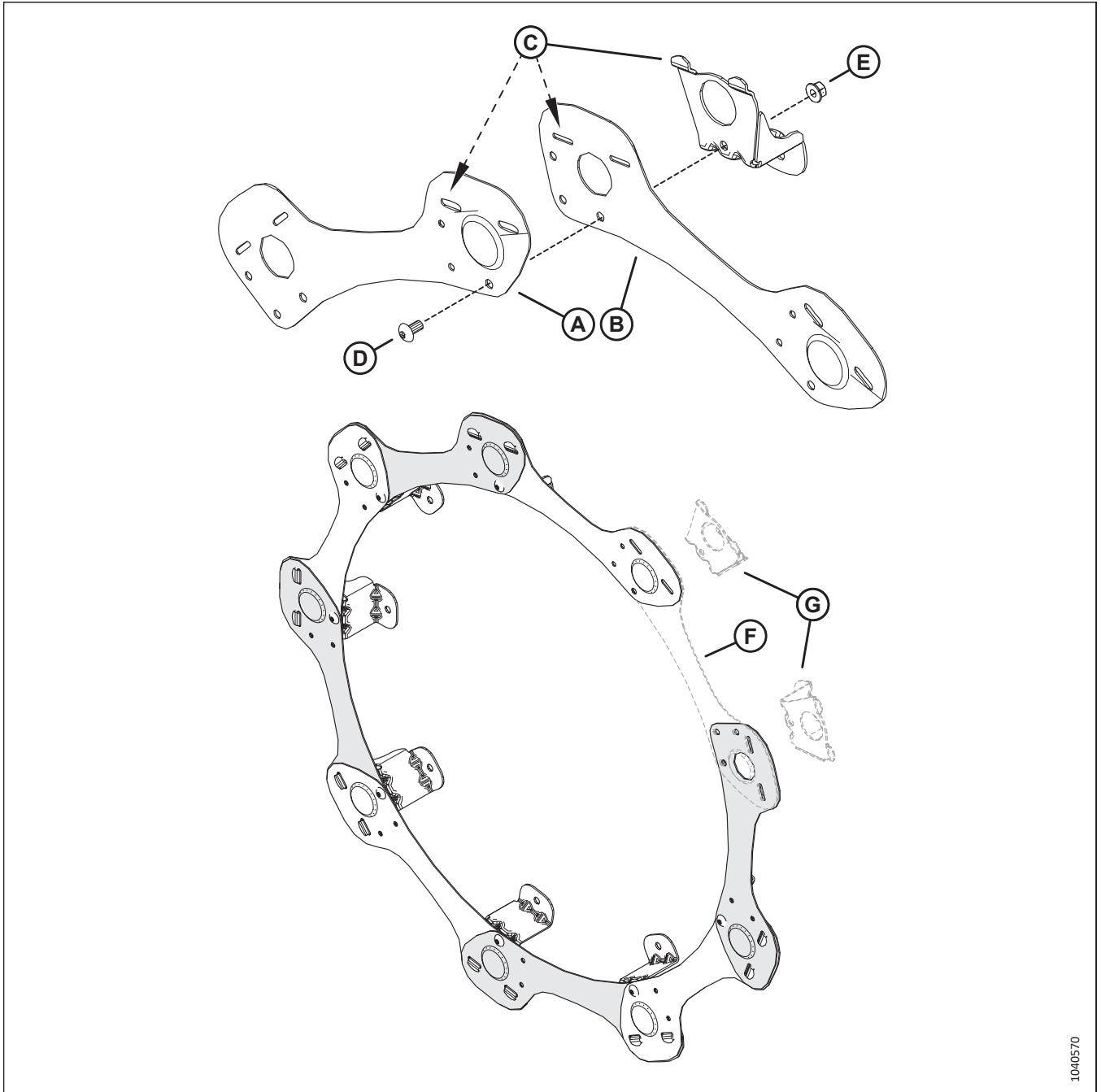
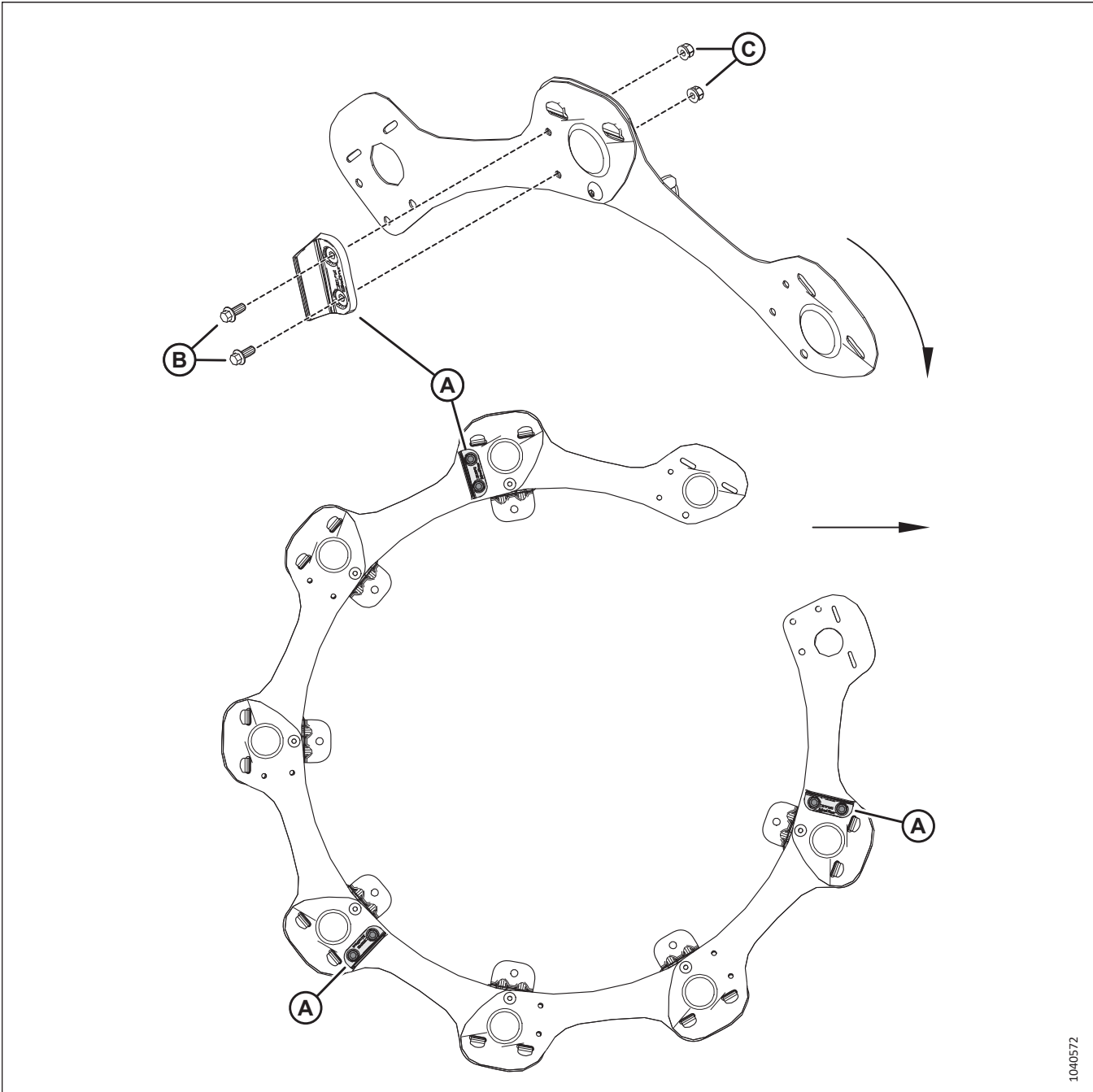

Figure 5.89: Nine-Bat Reel – Initial Endshield Assembly

2. Position one endshield segment (A) on top of another segment (B). Engage endshield support tabs (C) through both segments.
3. Secure the segments with M10 Torx® screw (D) (MD #136395) and nut (E) (MD #135799). Do **NOT** tighten the hardware yet.
4. Repeat the previous step for the remaining segments, except do **NOT** install last segment (F) and two supports (G) yet.

COMPLETING HEADER ASSEMBLY



1040572

Figure 5.90: Nine-Bat Reel – Initial Endshield Assembly

5. Install three rubber reel end paddles (A) on the outboard face of the endshield assembly using two M8 bolts (B) (MD #136300) and nuts (C) (MD #135337) per paddle.

IMPORTANT:

The arrows point to the front of the machine. Ensure that the rubber paddles are oriented as shown.

COMPLETING HEADER ASSEMBLY

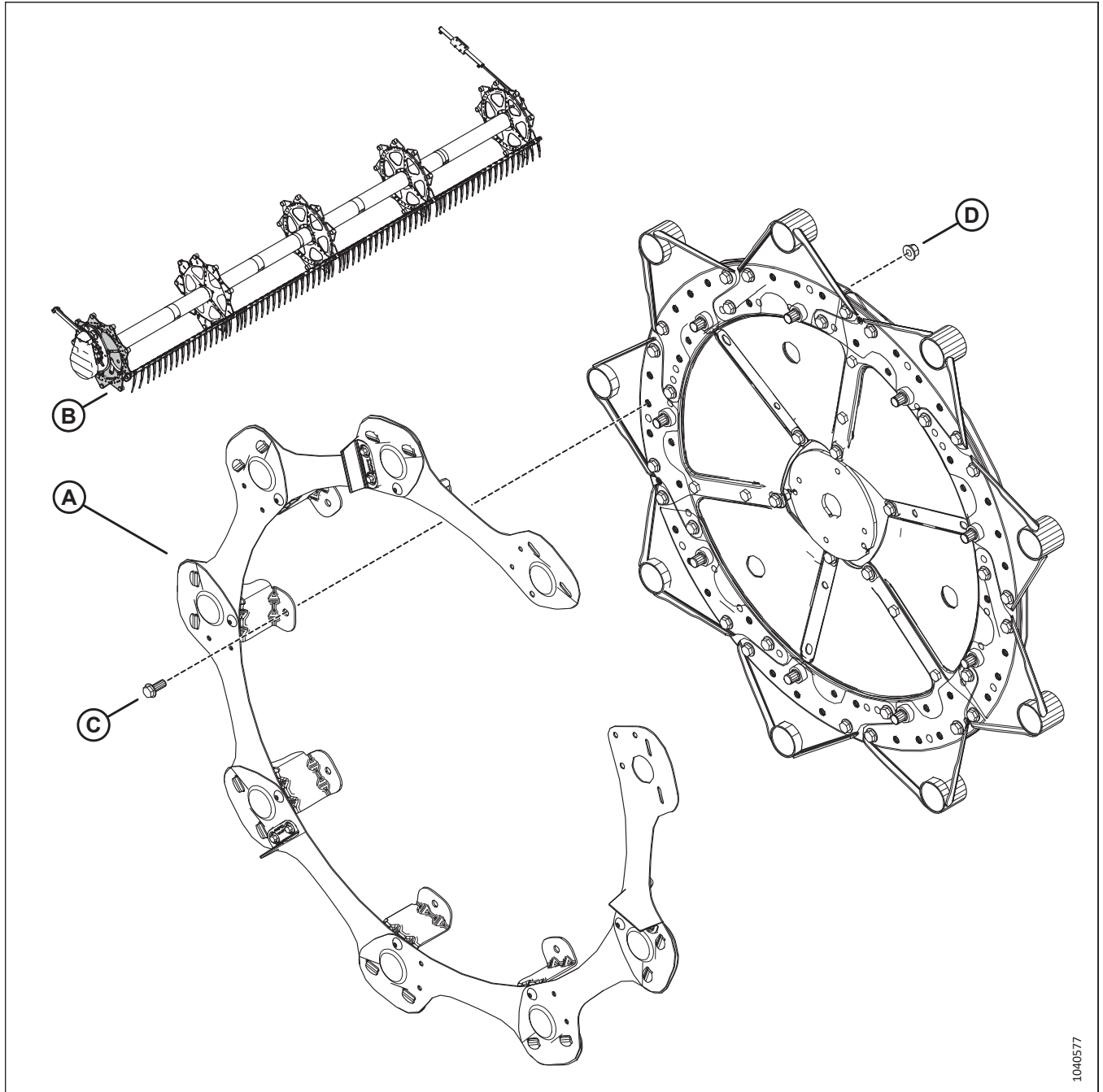
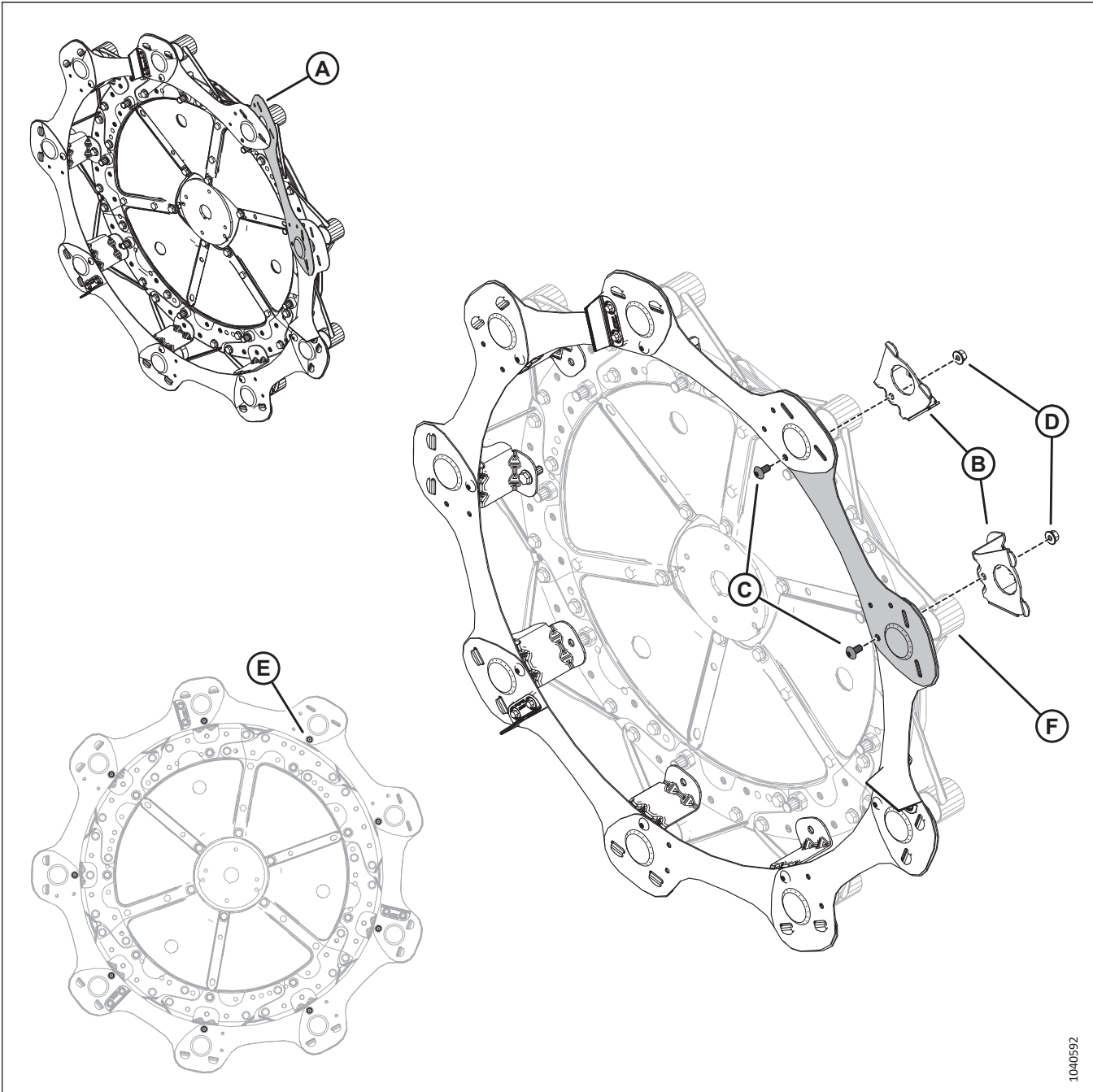

Figure 5.91: Nine-Bat Reel – Initial Endshield Assembly

6. Attach endshield assembly (A) to the cam-end reel disc (B) with one M12 bolt (C) (MD #320180) and nut (D) (MD #136431). Do **NOT** tighten the hardware yet.

COMPLETING HEADER ASSEMBLY



1040592

Figure 5.92: Nine-Bat Reel – Initial Endshield Assembly

7. Position ninth endshield (A) into place.
8. Insert the tabs of two endshield supports (B) through the endshield segments. Secure the endshield supports with two M10 Torx® screws (C) (MD #136395) and nuts (D) (MD #135799).
9. Tighten all nine M10 Torx® screws (E) to 39 Nm (29 lbf-ft).
10. Install the endshield supports on tine tubes (F).

COMPLETING HEADER ASSEMBLY

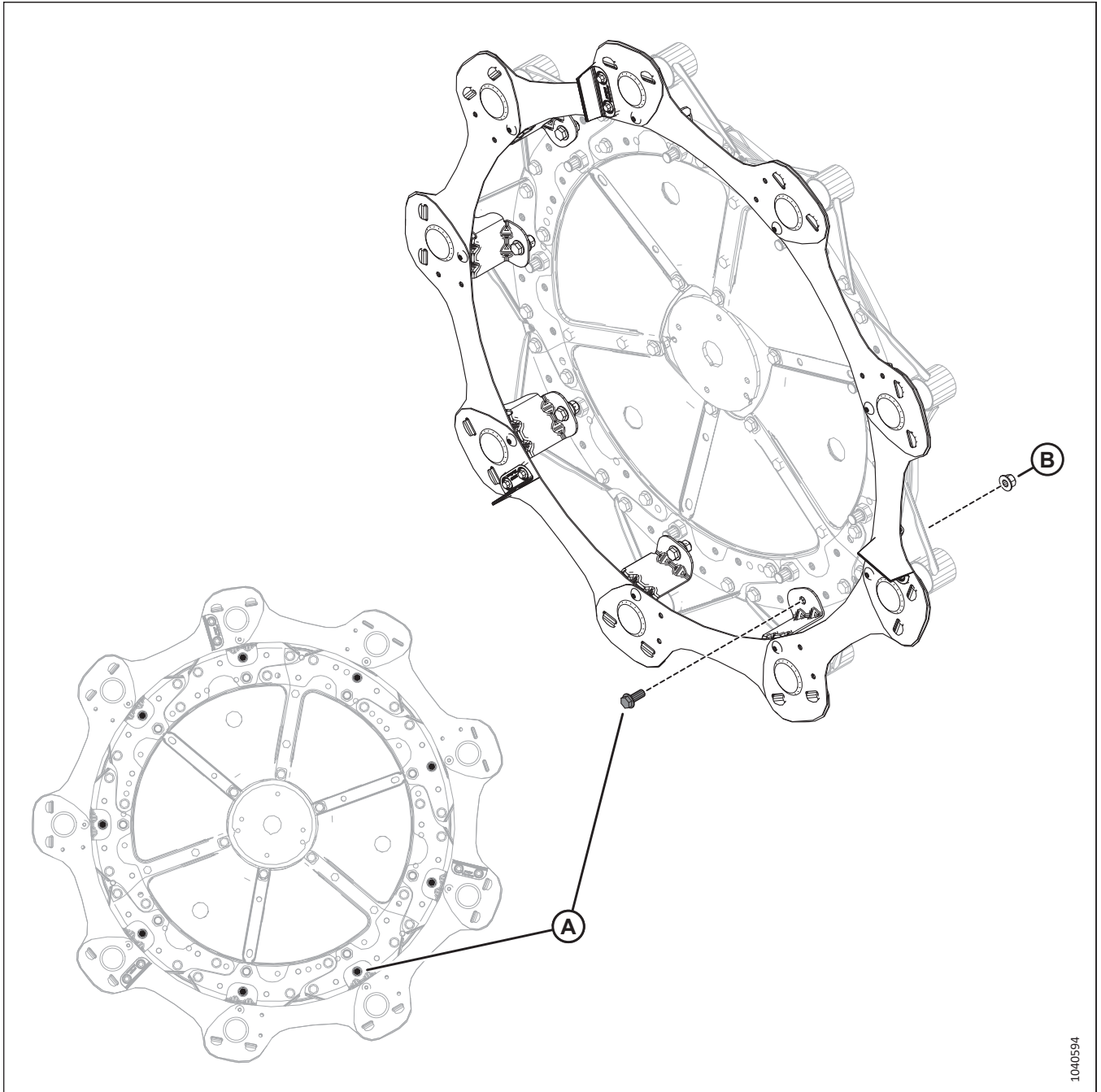

Figure 5.93: Nine-Bat Reel – Initial Endshield Assembly

11. Secure the remaining eight endshield supports to the reel disc using one M12 bolt (A) (MD #320180) and nut (B) (MD #136431).
12. Tighten all nine M12 bolts (A) to 69 Nm (51 lbf-ft).

5.18.2 Installing Single-Reel Endshields at Tail End – Nine-Bat

Single-reel headers have had the tail-end reel endshield parts removed for shipping purposes. These parts will need to be assembled and installed on the reel.

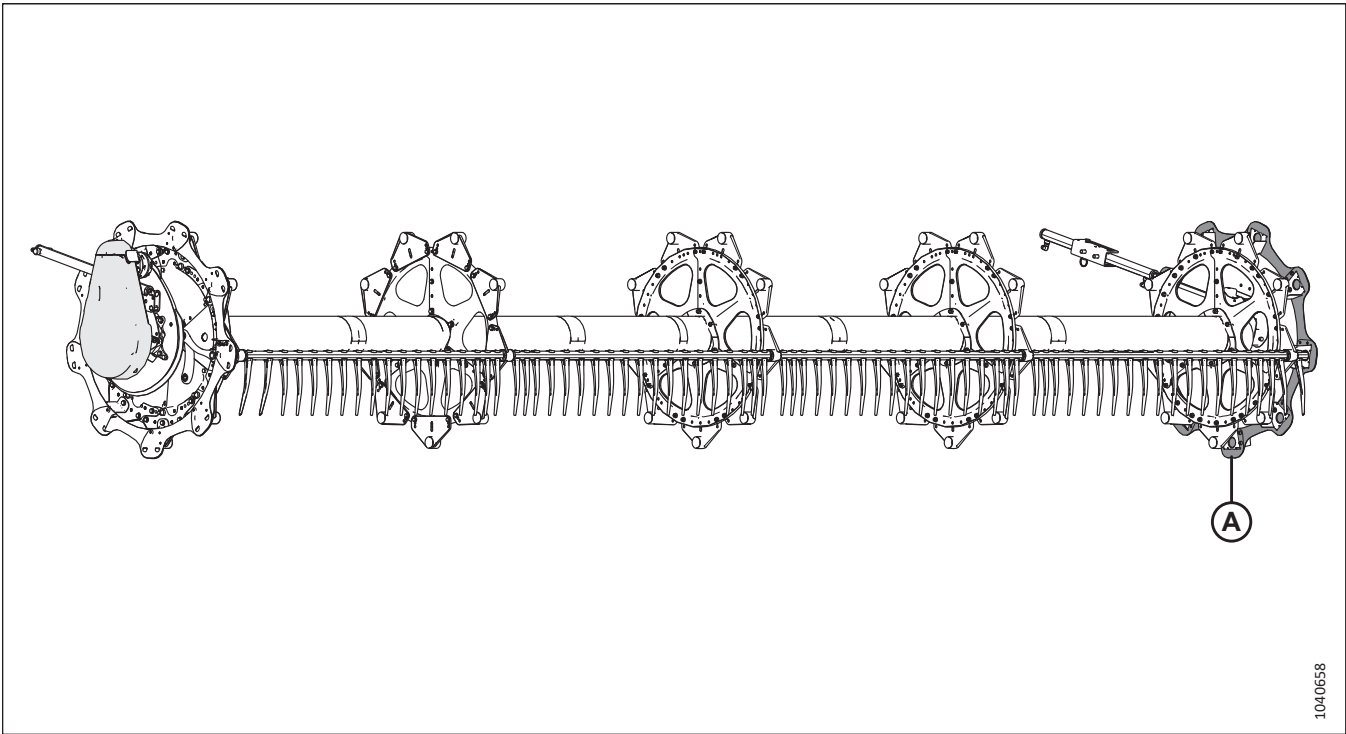

Figure 5.94: Nine-Bat Single-Reel

NOTE:

Tail-end endshields (A) are installed on the left of the reel.

COMPLETING HEADER ASSEMBLY

1. Retrieve parts bag (1) labeled with MD #368328. From that bag, retrieve the parts listed in Table 5.7, page 159.

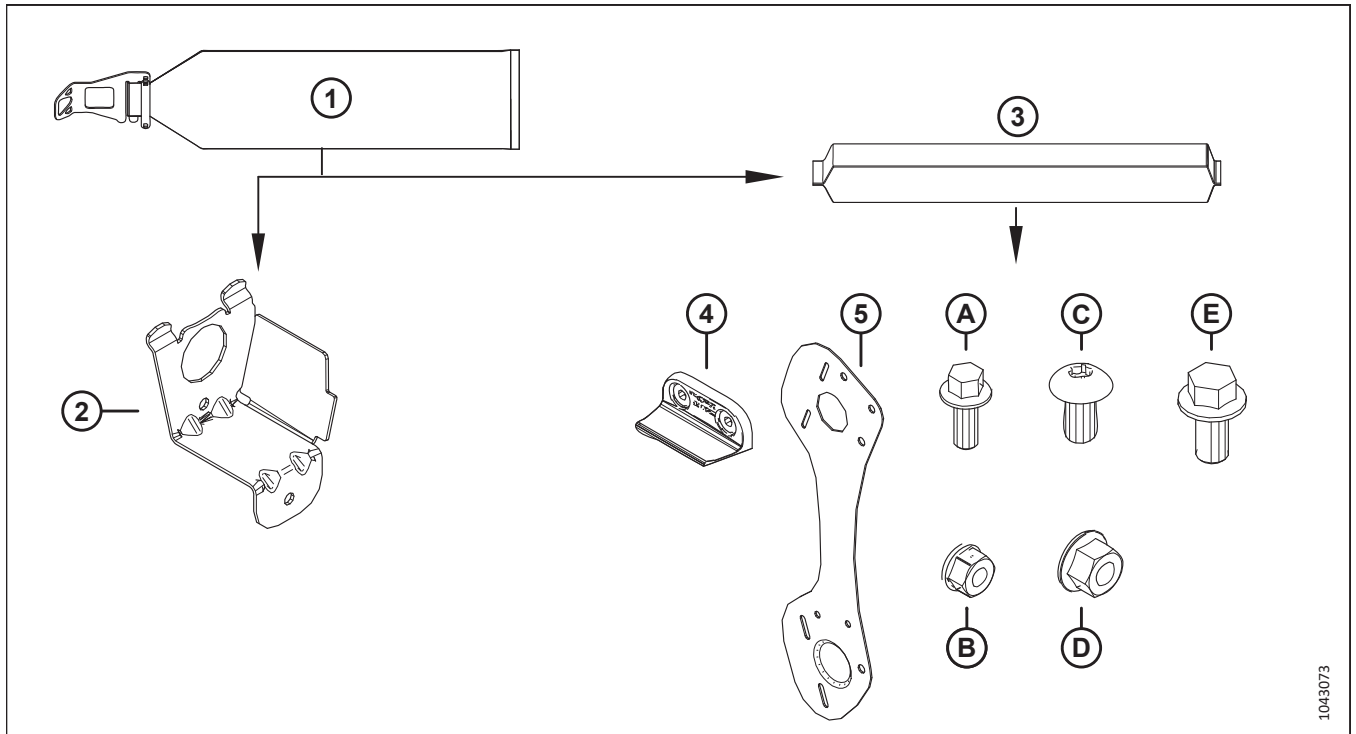

Figure 5.95: Parts to Retrieve from Nine-Bat Reel Endshields Parts Bag – MD #368328

Table 5.7 Parts to Retrieve from Nine-Bat Reel Endshields Parts Bag – MD #368328

Ref	Part Number	Description	Quantity to Retrieve
2	311965 – see note ³	SUPPORT – TAIL END	9
3	368336 or “LH”	ENDSHLD BAG – 9 BAT LH OB TAIL NOTE: This bag contains the parts listed below.	1
4	313035	PADDLE – REEL END; HYTREL	3
5	311864	SHIELD – OUTBOARD LH 9 BAT	9
A	136300	BOLT – HEX FLG HD TFL M8X1.25X20-8.8-AA3L	6
B	135337	NUT – HEX FLG CTR LK M8X1.25-8-AA1J	6
C	136395	SCR – TORX TRUSS HD M10X1.5X20XSPCL-8.8-A3L	9
D	135799	NUT – HEX FLG CTR LOC M10X1.5-10	18
E	152655	BOLT – HEX FLG HD M10X1.5X20-8.8-AA1J	9

3. These parts are marked with a yellow cable tie to indicate that they belong with parts bag (3) (“LH”, MD #368336) which should also be marked with a yellow cable tie.

COMPLETING HEADER ASSEMBLY

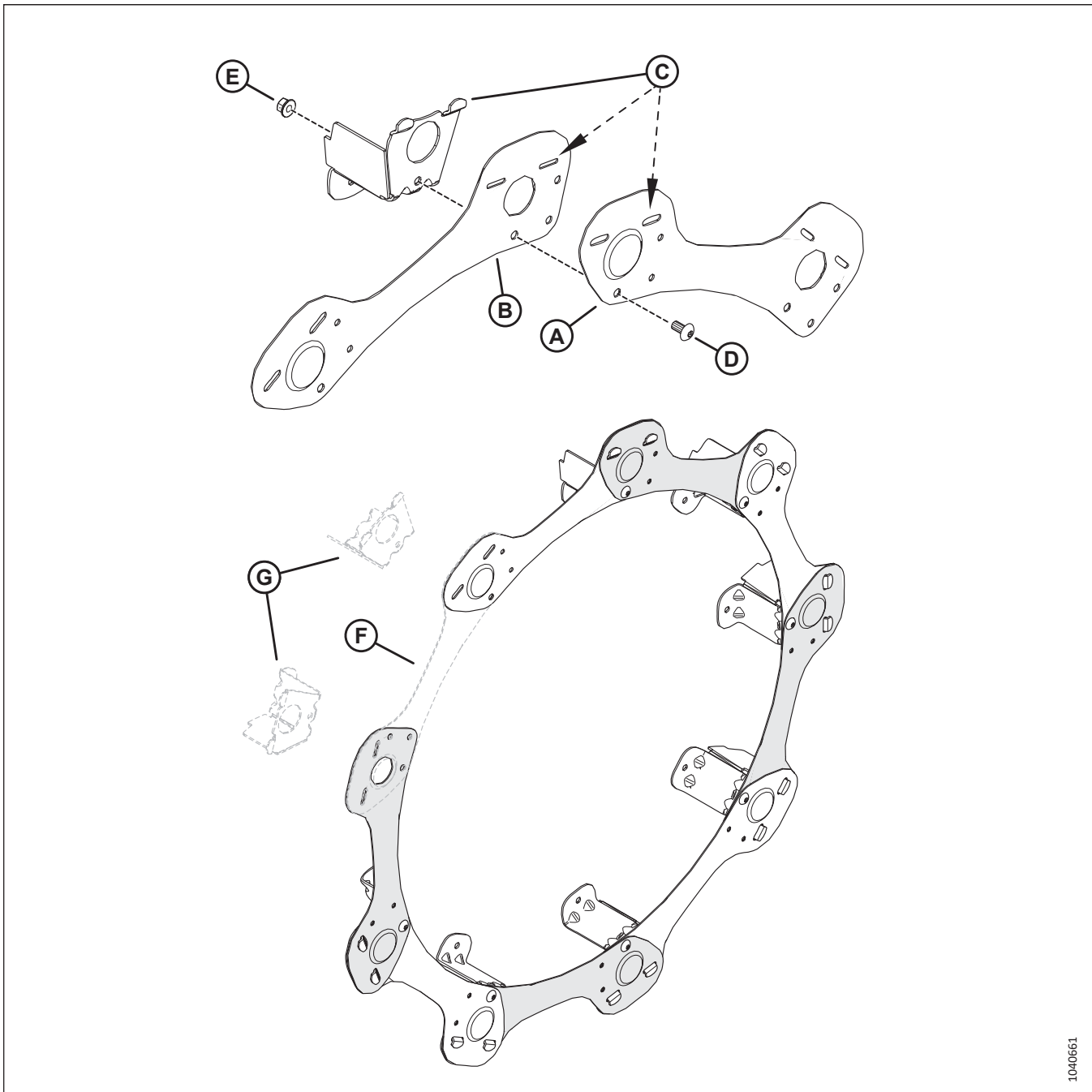

1040661

Figure 5.96: Nine-Bat Reel – Initial Endshield Assembly

2. Position one endshield segment (A) on top of another segment (B). Engage endshield support tabs (C) through both segments.
3. Secure the segments with M10 Torx® screw (D) (MD #136395) and nut (E) (MD #135799). Do **NOT** tighten the hardware yet.
4. Repeat the previous step for the remaining segments, except do **NOT** install last segment (F) and two supports (G) yet.

COMPLETING HEADER ASSEMBLY

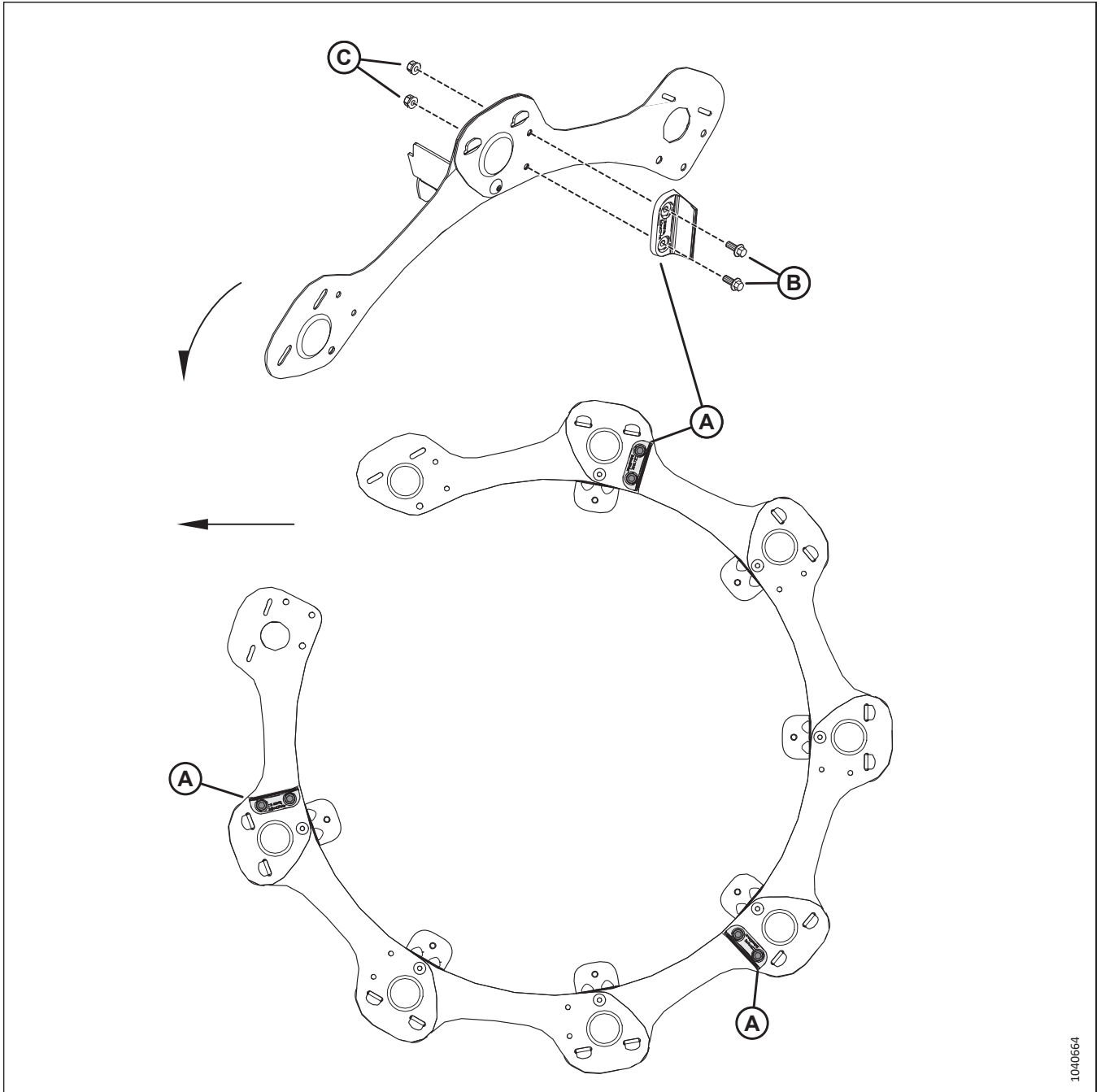

Figure 5.97: Nine-Bat Reel – Initial Endshield Assembly

5. Install three rubber reel end paddles (A) on the outboard face of the endshield assembly using two M8 bolts (B) (MD #136300) and nuts (C) (MD #135337) per paddle.

IMPORTANT:

The arrows point to the front of the machine. Ensure that the rubber paddles are oriented as shown.

COMPLETING HEADER ASSEMBLY

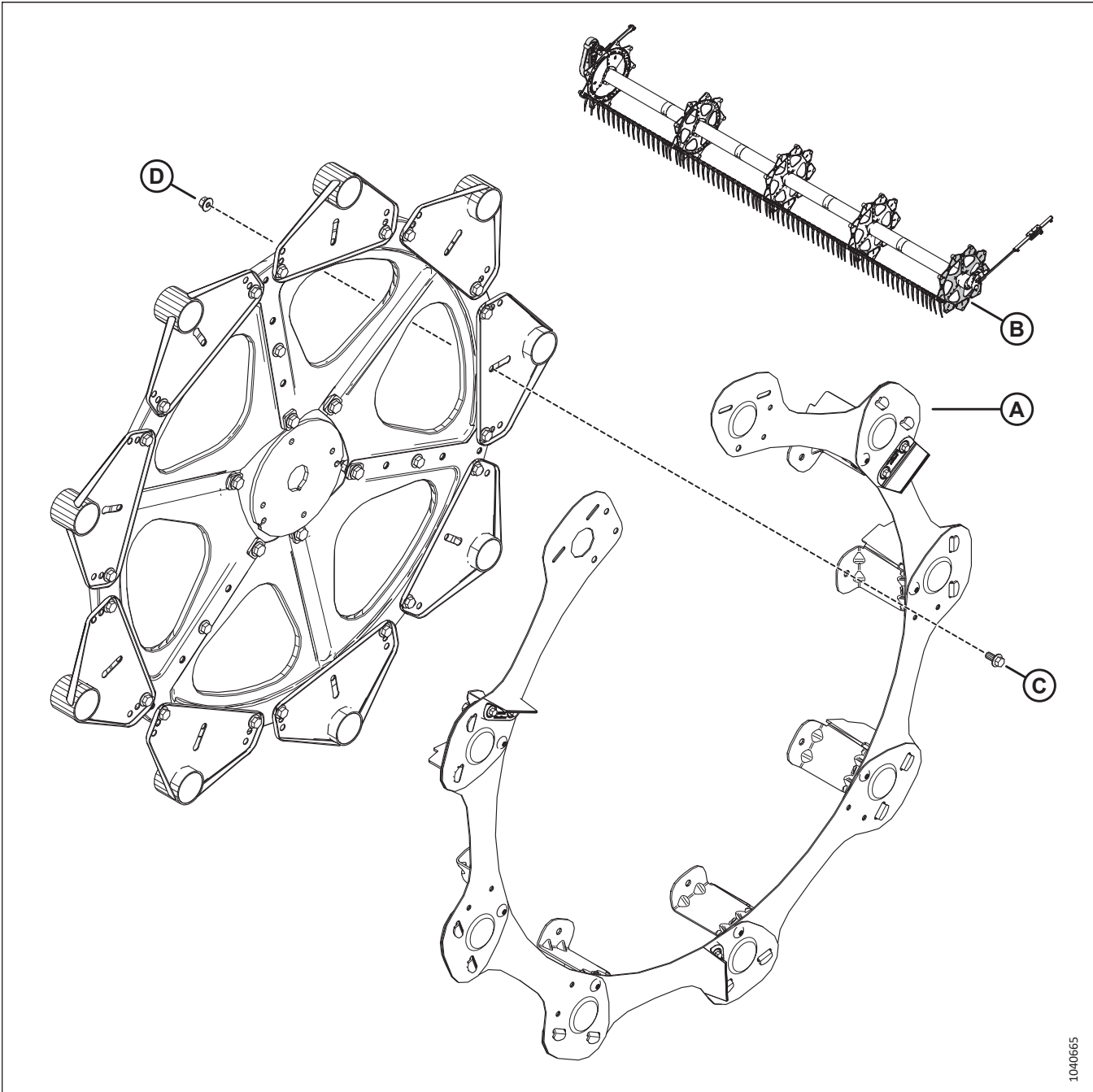

1040665

Figure 5.98: Nine-Bat Reel – Initial Endshield Assembly

6. Attach endshield assembly (A) to the cam-end reel disc (B) with one M10 bolt (C) (MD #152655) and nut (D) (MD #135799). Do **NOT** tighten the hardware yet.

COMPLETING HEADER ASSEMBLY

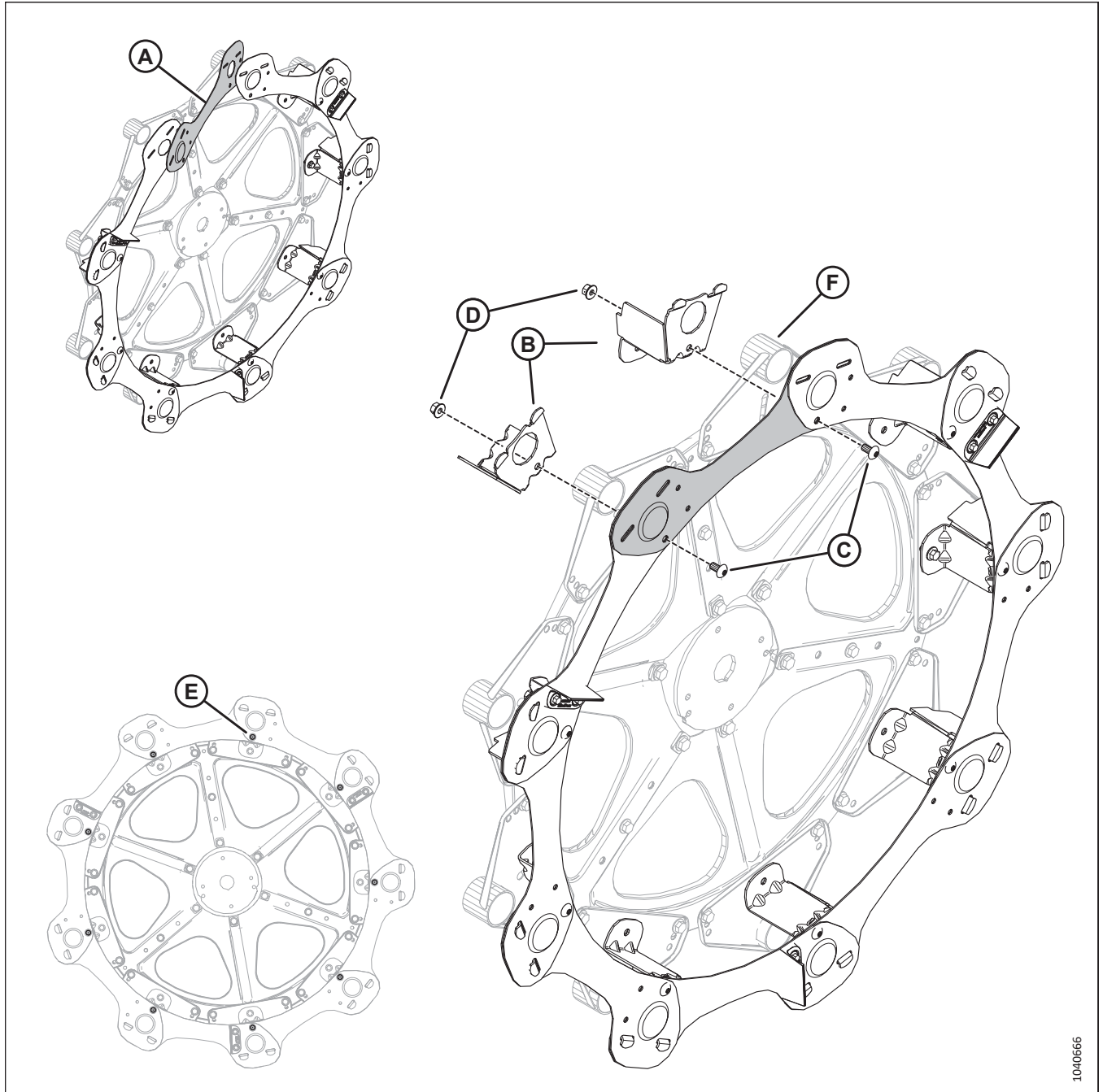
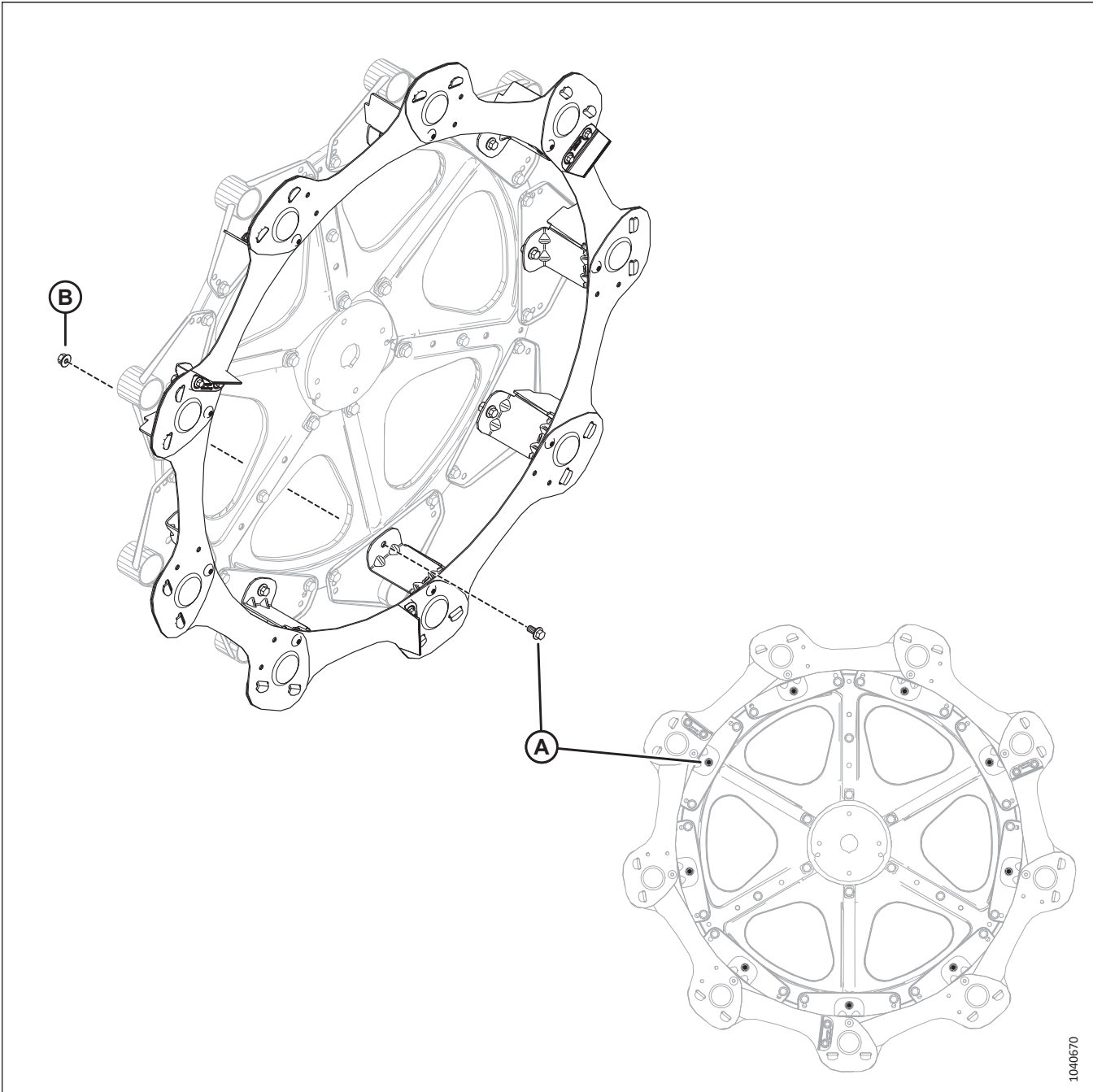

Figure 5.99: Nine-Bat Reel – Initial Endshield Assembly

7. Position ninth endshield (A) into place.
8. Insert the tabs of two endshield supports (B) through the endshield segments. Secure the endshield supports with two M10 Torx® screws (C) (MD #136395) and nuts (D) (MD #135799).
9. Tighten all nine M10 Torx® screws (E) to 39 Nm (29 lbf-ft).
10. Install the endshield supports on tine tubes (F).

COMPLETING HEADER ASSEMBLY



1040670

Figure 5.100: Nine-Bat Reel – Initial Endshield Assembly

11. Secure the remaining eight endshield supports to the reel disc using one M10 bolt (A) (MD #152655) and nut (B) (MD #135799).
12. Tighten all nine M10 bolts (A) to 68.5 Nm (50.5 lbf-ft).

5.19 Installing Double-Reel Endshields – Parts Bag MD #368322 (Five-Bat Reels) or MD #368323 (Six-Bat Reels)

The reel endshields on double-reel headers have been removed for shipping purposes. The reel endshields will need to be unpacked and installed on the header.

NOTE:

As of model year 2023, D2 Series Draper Headers sold in North America are only offered in six-bat reels. The endshield assembly illustrations and steps throughout this section of the manual show five-bat reels except where noted. The installation procedure for six-bat reels is similar.

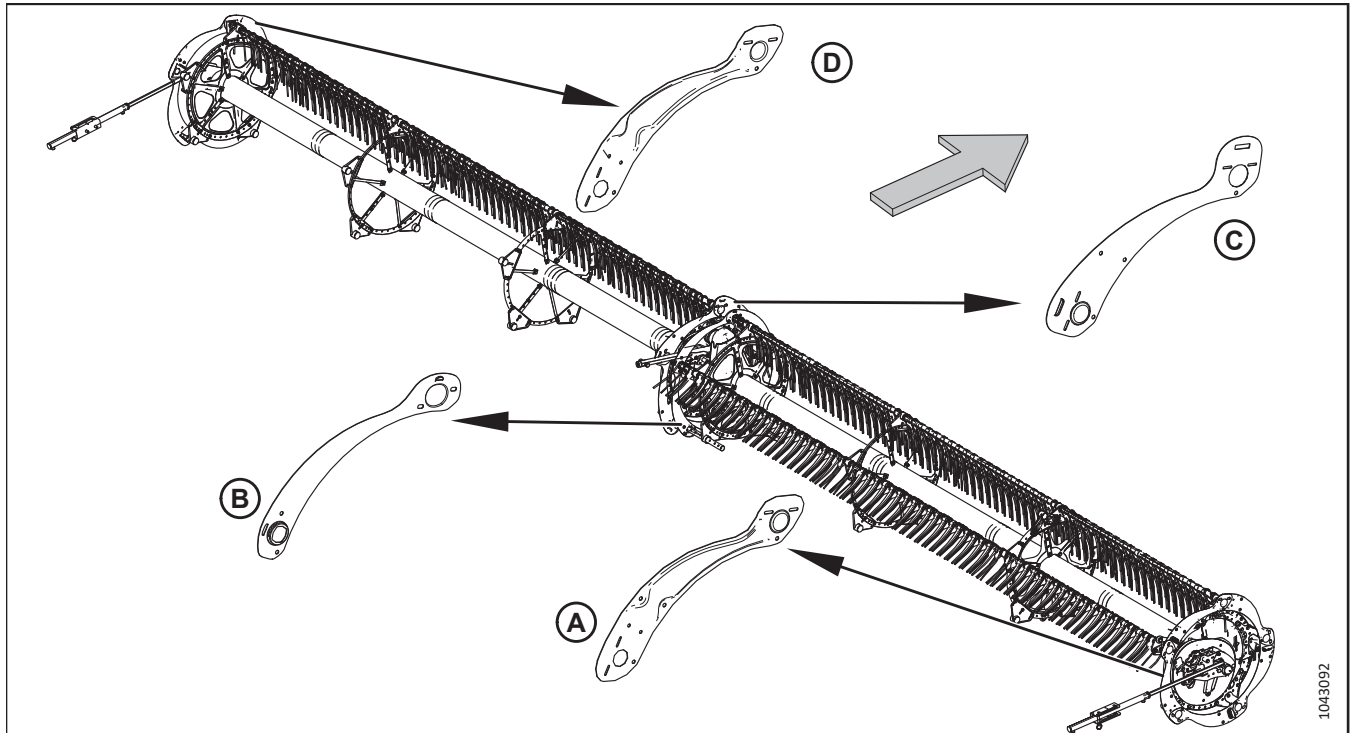

Figure 5.101: Reel Endshields – Double-Reel Endshield (Five-Bat Reel Shown)

NOTE:

The large arrow indicates the front of the header.

1. Retrieve the parts bag containing the endshields:

- **Five-bat reel:** Retrieve parts bag MD #368322.
- **Six-bat reel:** Retrieve parts bag MD #368323.

NOTE:

Parts lists and illustrations are included in the procedures referenced in the steps below.

2. Install outboard cam-end endshields (A). For instructions, refer to [5.19.1 Installing Double-Reel Endshields at Outboard Cam End, page 166](#).
3. Install inboard tail-end endshields (B). For instructions, refer to [5.19.2 Installing Double-Reel Endshields at Inboard Tail End, page 174](#).
4. Install inboard cam-end endshields (C). For instructions, refer to [5.19.3 Installing Double-Reel Endshields at Inboard Cam End, page 181](#).

COMPLETING HEADER ASSEMBLY

5. Install outboard tail-end endshields (D). For instructions, refer to [5.19.4 Installing Double-Reel Endshields at Outboard Tail End, page 188](#).

5.19.1 Installing Double-Reel Endshields at Outboard Cam End

Endshields need to be installed at the cam end of the right reel to prevent crop from wrapping around the reel.

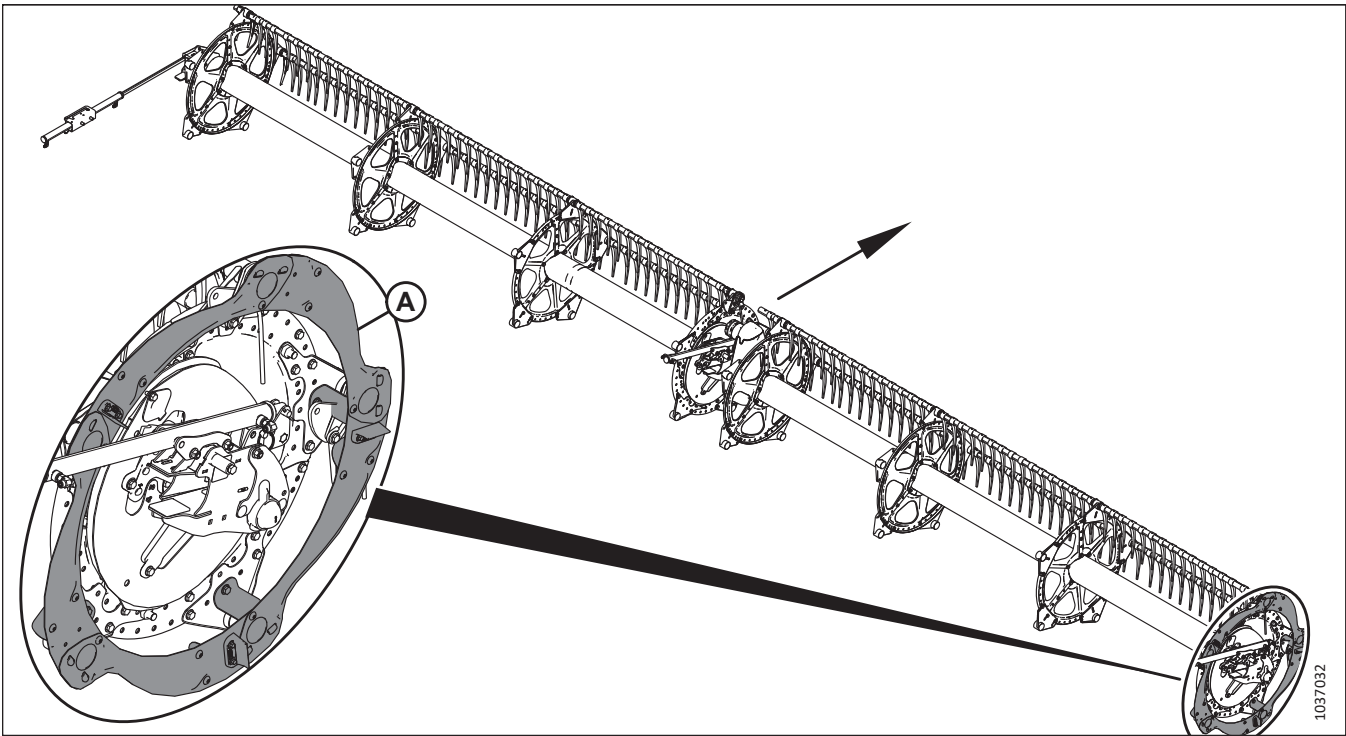

Figure 5.102: Five-Bat Double Reel

NOTE:

Outboard cam-end endshields (A) are installed on the right of the reel.

NOTE:

The arrow in the illustration indicates the front of the header.

NOTE:

This procedure applies to five-bat reels. The procedure for six-bat reels is similar.

COMPLETING HEADER ASSEMBLY

1. **Five-bat reels:** Retrieve parts bag (1) labeled with MD #368322. From that bag, retrieve the parts listed in Table 5.8, page 167.

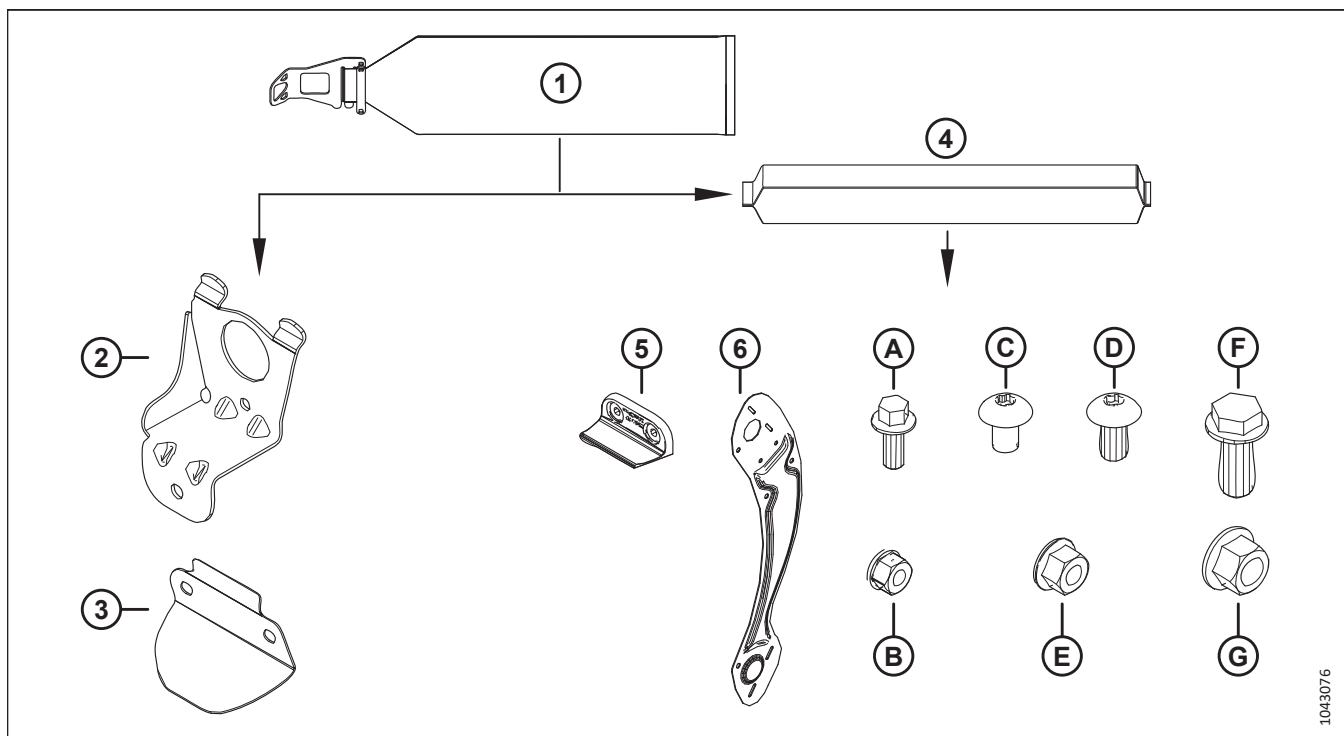

Figure 5.103: Five-Bat Reel Endshield Parts Bag (MD #368322)

Table 5.8 Parts to Retrieve from Five-Bat Reel Endshields Parts Bag (MD #368322)

Ref	Part Number	Description	Quantity
2	311964 – see note ⁴	SUPPORT – CAM END	5
3	311729 – see note ⁴	DEFLECTOR – CAM OUTBOARD	5
4	368332 (“RH CAM”)	ENDSHLD BAG – 5 BAT RH OB CAM NOTE: This bag contains the parts listed below.	1
5	313035	PADDLE – REEL END; HYTREL	3
6	311694	SHIELD – OUTBOARD RH 5 BAT	5
A	136300	BOLT – HEX FLG HD TFL M8X1.25X20-8.8-AA3L	6
B	135337	NUT – HEX FLG CTR LK M8X1.25-8-AA1J	6
C	136640	SCR – TORX TRUSS HD M10X1.5X16XSPCL-8.8-AA1J	10
D	136395	SCR – TORX TRUSS HD M10X1.5X20XSPCL-8.8-A3L	5
E	135799	NUT – HEX FLG CTR LOC M10X1.5-10	15
F	320180	BOLT – HEX FLG HD M12X1.75X30-SPCL-8.8-ZINC	5
G	136431	NUT – HEX FLG CTR LOC M12X1.75-10	5

4. These parts are marked with a red cable tie to indicate that they belong with parts bag (4) (“RH CAM”, MD #368332) which should also be marked with a red cable tie.

COMPLETING HEADER ASSEMBLY

2. **Six-bat reels:** Retrieve parts bag (1) labeled with MD #368323. From that bag, retrieve the parts listed in Table 5.9, page 168.

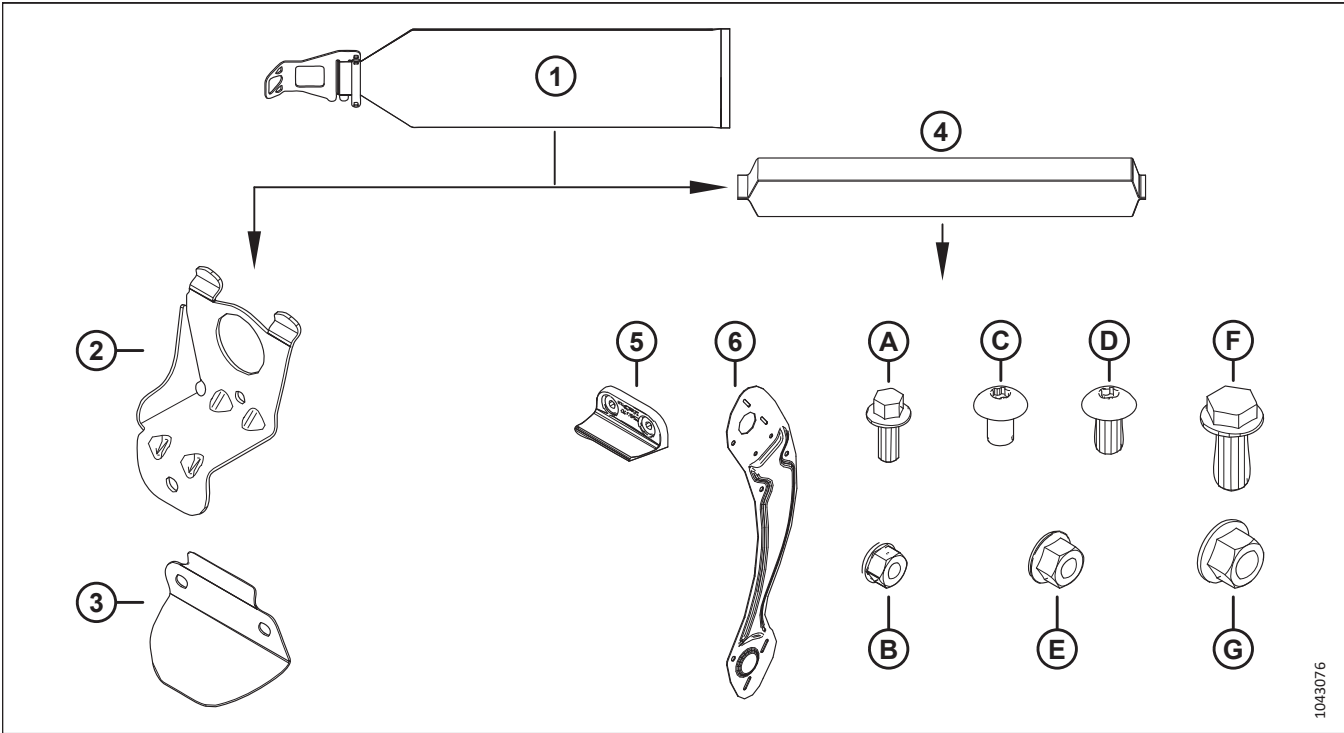

Figure 5.104: Six-Bat Reel Endshield Parts Bag (MD #368323)

Table 5.9 Parts to Retrieve from Six-Bat Reel Endshields Parts Bag (MD #368323)

Ref	Part Number	Description	Quantity
2	311964 – see note ⁵	SUPPORT – CAM END	6
3	311729 – see note ⁵	DEFLECTOR – CAM OUTBOARD	6
4	368335 (“RH CAM”)	ENDSHLD BAG – 6 BAT RH OB CAM NOTE: This bag contains the parts listed below.	1
5	313035	PADDLE – REEL END; HYTREL	3
6	311752	SHIELD – OUTBOARD RH 6 BAT	6
A	136300	BOLT – HEX FLG HD TFL M8X1.25X20-8.8-AA3L	6
B	135337	NUT – HEX FLG CTR LK M8X1.25-8-AA1J	6
C	136640	SCR – TORX TRUSS HD M10X1.5X16XSPL-8.8-AA1J	12
D	136395	SCR – TORX TRUSS HD M10X1.5X20XSPL-8.8-A3L	6
E	135799	NUT – HEX FLG CTR LOC M10X1.5-10	18
F	320180	BOLT – HEX FLG HD M12X1.75X30-SPL-8.8-ZINC	6
G	136431	NUT – HEX FLG CTR LOC M12X1.75-10	6

5. These parts are marked with a red cable tie to indicate that they belong with parts bag (4) (“RH CAM”, MD #368335) which should also be marked with a red cable tie.

COMPLETING HEADER ASSEMBLY

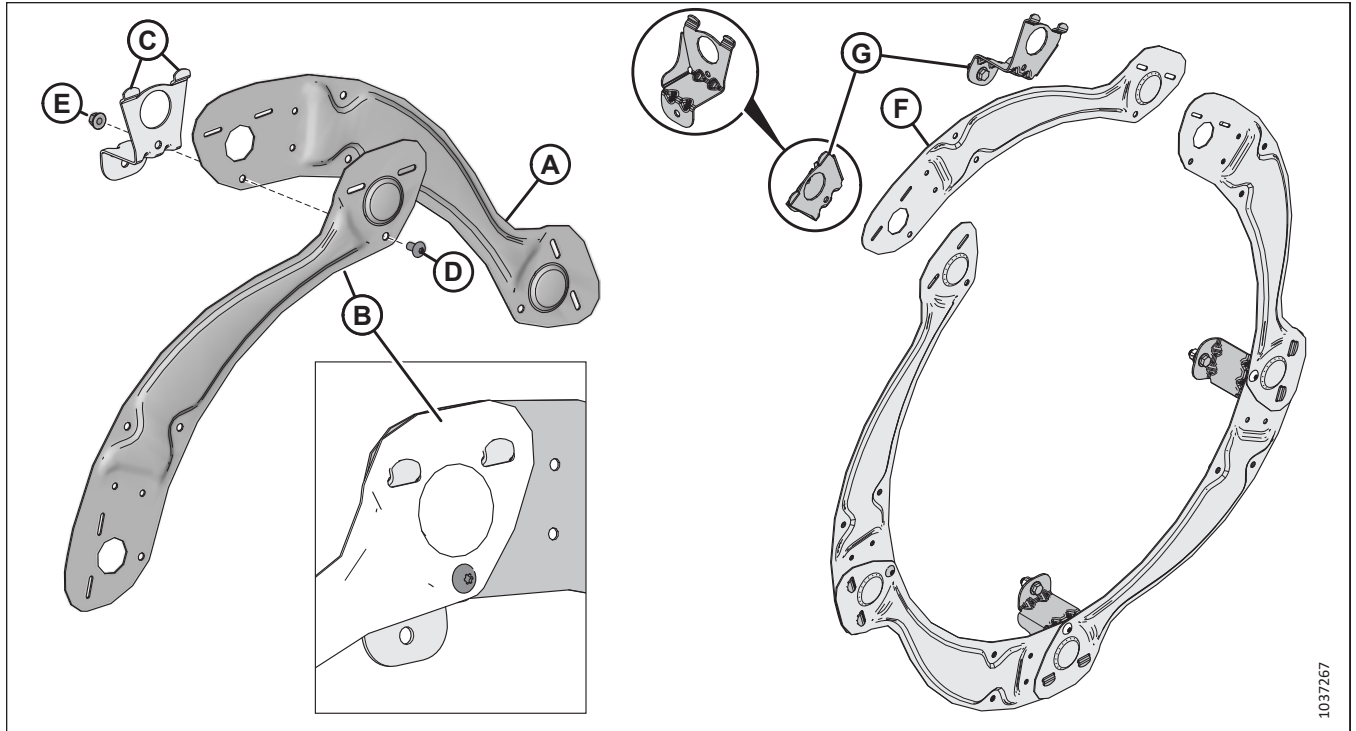

Figure 5.105: Five-Bat Reel – Initial Endshield Assembly

3. Assemble the endshield as follows:

- a. Position endshield segment (A) behind segment (B). Engage endshield support tabs (C) through both segments. Secure the segments with M10 X 1.5 X 20 Torx® screw (D) and hex nut (E). Do **NOT** tighten the hardware yet.
- b. Repeat step (a.) for the remaining segments. Do **NOT** install last segment (F) and two support tabs (G) yet.

COMPLETING HEADER ASSEMBLY

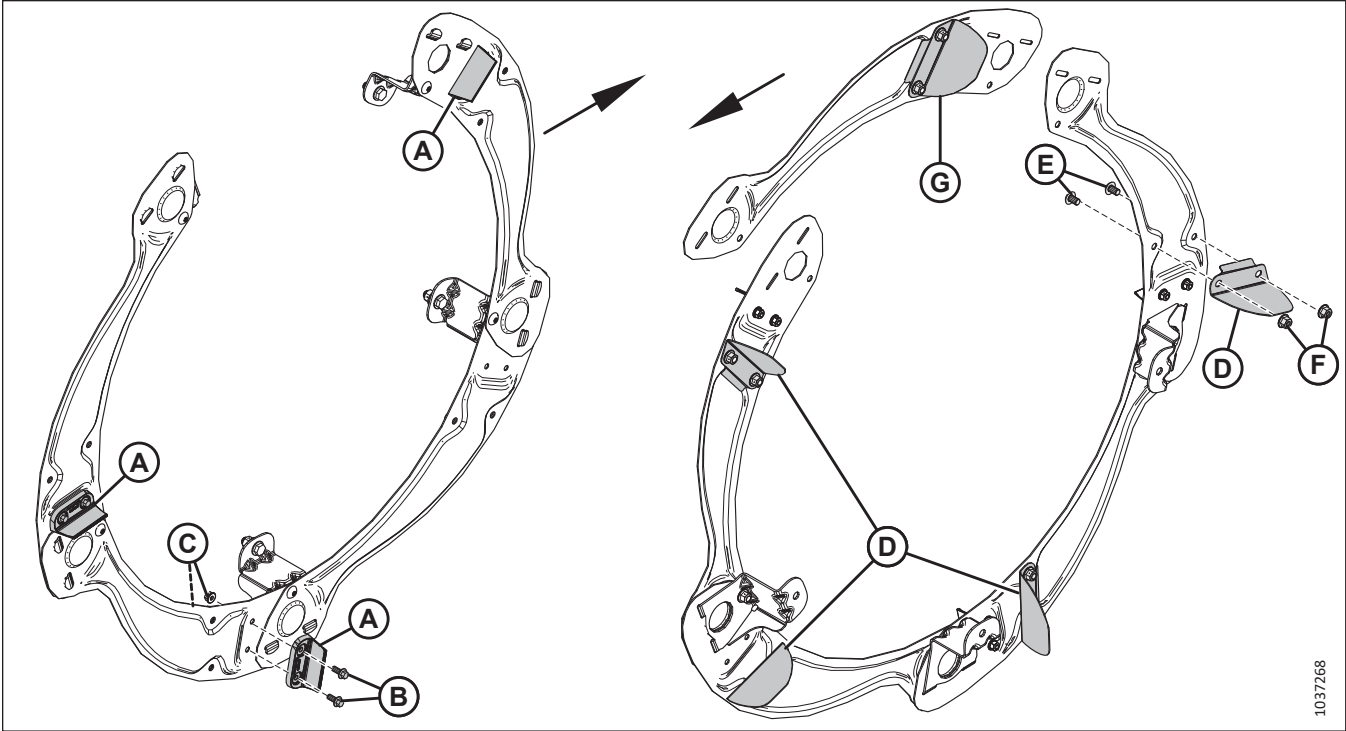

Figure 5.106: Five-Bat Reel – Rubber Paddles and Aluminum Cam Deflectors

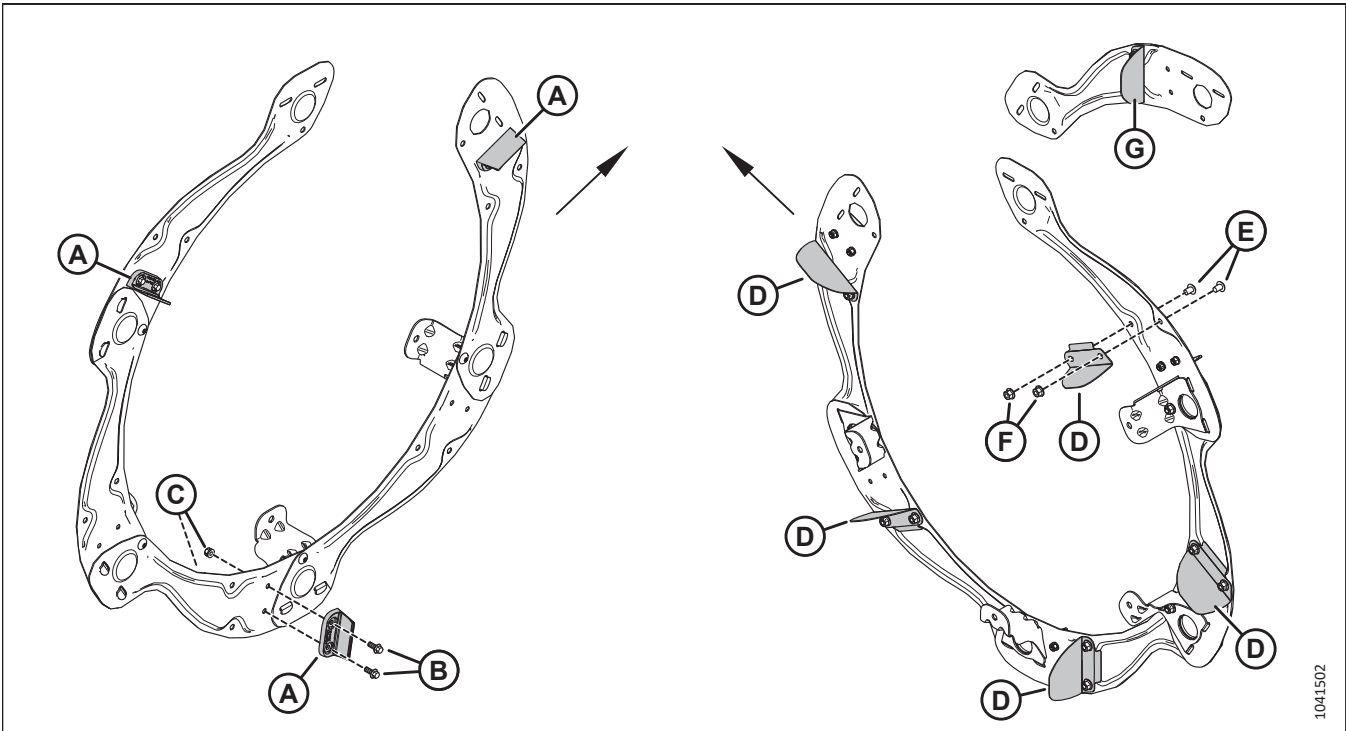

Figure 5.107: Six-Bat Reel – Rubber Paddles and Aluminum Cam Deflectors

NOTE:

For five-bat reels, refer to Figure 5.106, page 170. For six-bat reels, refer to Figure 5.107, page 170.

COMPLETING HEADER ASSEMBLY

4. Install all rubber reel end paddles (A) on the outboard face of the endshield assembly using two M8 X 1.25 X 20 hex bolts (B) and nuts (C) per paddle.

IMPORTANT:

Ensure that the rubber paddles and cam deflectors are oriented as shown.

5. Install aluminum cam deflectors (D) (MD #311729) on the inboard face of the endshield assembly shown using two M10 X 1.5 X 16 Torx® screws (E) and hex nuts (F).
6. Install aluminum cam deflector (G) (MD #311729) on the last segment as shown using two M10 X 1.5 X 16 Torx® screws and hex nuts.

COMPLETING HEADER ASSEMBLY

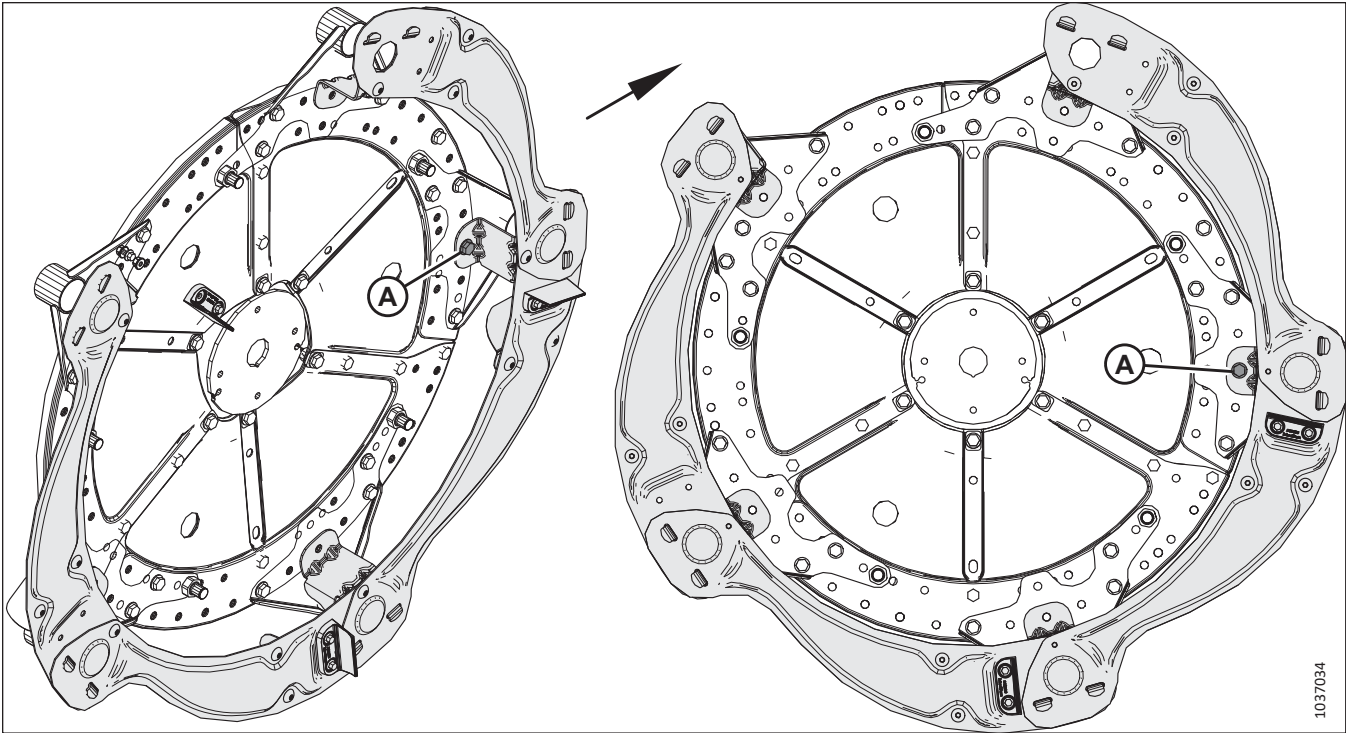

Figure 5.108: Five-Bat Reel – Partially Assembled Reel Endshields on Reel

7. Position the partially assembled reel endshield on the reel.
8. Secure the endshield to the reel with one M12 X 1.75 X 30 hex bolt and nut (A). Do **NOT** tighten the hardware yet.

COMPLETING HEADER ASSEMBLY

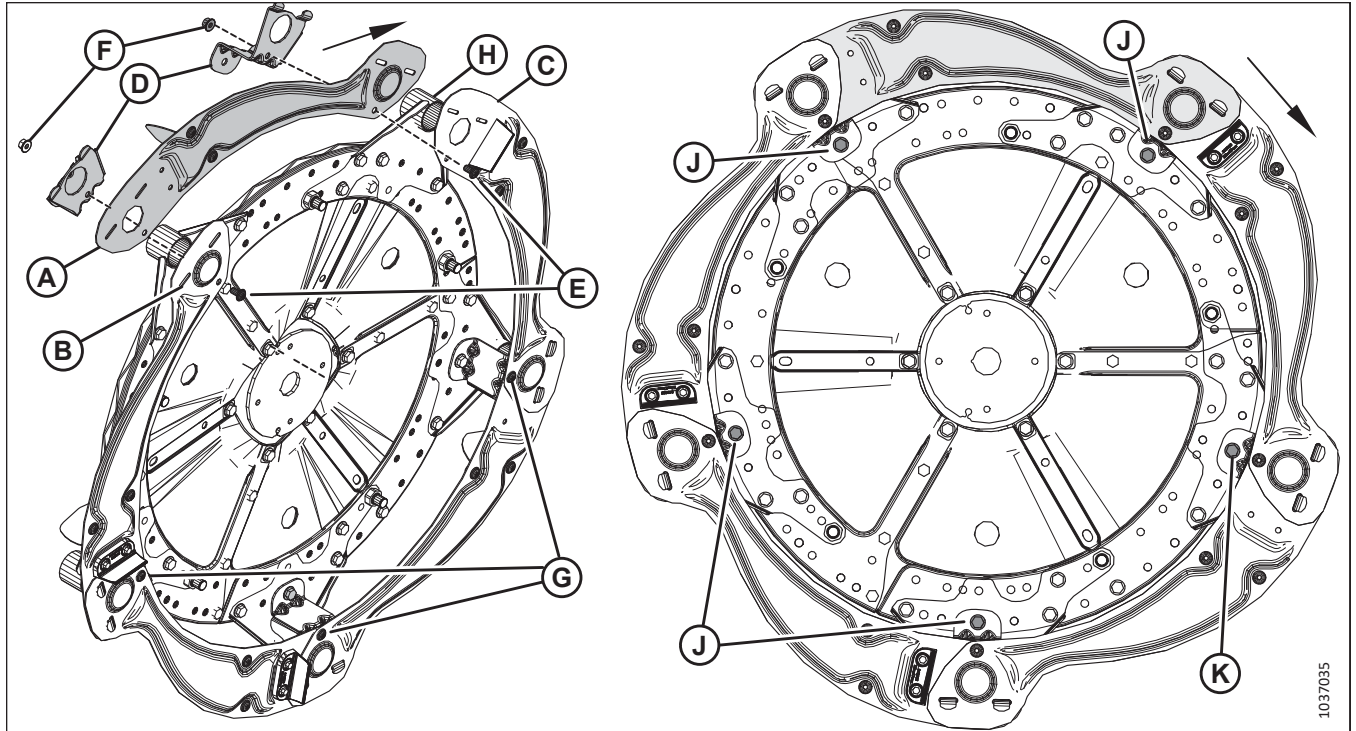

Figure 5.109: Five-Bat Reel – Partially Assembled Reel Endshields on Reel

9. Install the last segment of endshield (A) as follows:
 - a. Position the wide end of last segment (A) behind segment (B). Position the other end of the last segment on top of segment (C).
 - b. Insert the tabs of endshield supports (D) through the endshield segments.
 - c. Secure the endshield supports using two M10 X 1.5 X 20 Torx® screws (E) and nuts (F).
 - d. Torque five M10 X 1.5 X 20 Torx® screws (E) and (G) to 39 Nm (29 lbf·ft). Rotate the reel to reach the screws if required.
 10. Install the endshield supports on tine tubes (H).
- NOTE:**
Not all of the tine tubes are shown in the illustration.
11. Secure the remaining endshield supports to the reel disc using one M12 X 1.75 X 30 hex bolt (J) and nut per endshield support.
 12. Tighten M12 X 1.75 X 30 hex bolts (J) and (K) and the nuts securing the endshield supports to the cam discs to 69 Nm (51 lbf·ft).

5.19.2 Installing Double-Reel Endshields at Inboard Tail End

Endshields need to be installed on the tail end of the right reel to prevent crop from wrapping around the reel.

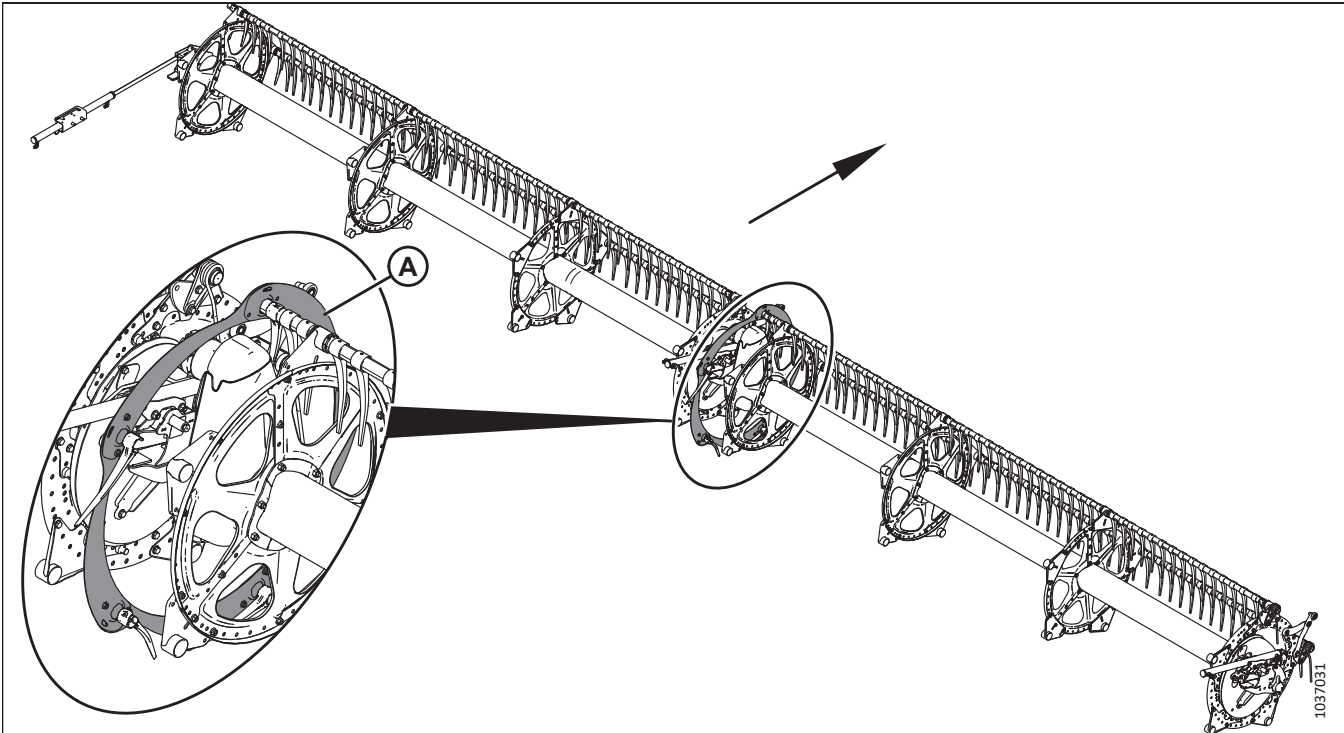

Figure 5.110: Five-Bat Double Reel

NOTE:

Inboard tail-end endshields (A) are installed on the left of the reel.

NOTE:

The arrow in the illustration indicates the front of the header.

NOTE:

This procedure applies to five-bat reels. The procedure for six-bat reels is similar.

1. If not already done at least once, raise the reel fully, and then lower it fully.

IMPORTANT:

Raising the reel fully, and then lowering it fully, will fill the hydraulic lines with oil and will purge them of air. Doing this before installing the inboard endshields will prevent the inboard endshields from contacting and damaging each other when the reel is subsequently raised.

COMPLETING HEADER ASSEMBLY

2. **Five-bat reels:** Retrieve parts bag (1) labeled with MD #368322. From that bag, retrieve the parts listed in Table 5.10, page 175.

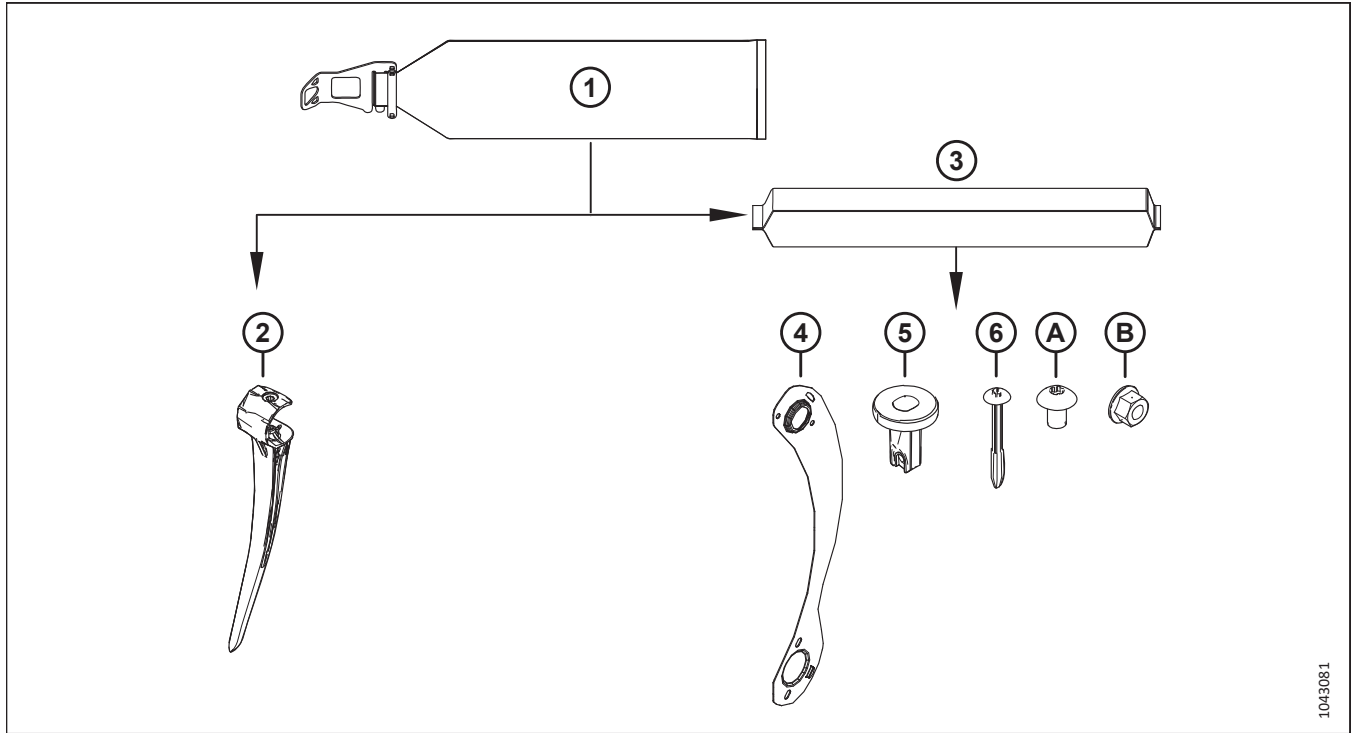

Figure 5.111: Five-Bat Reel Endshield Parts Bag MD #368322

Table 5.10 Parts to Retrieve from Five-Bat Reel Endshields Parts Bag MD #368322

Ref	Part Number	Description	Quantity
2	NSS see notes ⁶⁷	FINGER – PLASTIC – LH ANGLED 45 MM	5
3	368331 (“RH”)	ENDSHLD BAG – 5 BAT RH IB TAIL NOTE: This bag contains the parts listed below.	1
4	311795	SHIELD – 5 BAT RH REEL-TAIL END	5
5	273968	BUSHING – ENDSHIELD	5
6	252687	SCREW – 48° PLASTITE TWIN HELIX	5
A	136640	SCR – TORX TRUSS HD M10X1.5X16XSPCL-8.8-AA1J	10
B	135799	NUT – HEX FLG CTR LOC M10X1.5-10	10

6. Not sold separately. For service parts, can be ordered as a package of 10 (MD #360540).
 7. These parts are marked with a black cable tie to indicate that they belong with parts bag (3) (“RH IB TAIL”, MD #368331) which should also be marked with a black cable tie.

COMPLETING HEADER ASSEMBLY

3. **Six-bat reels:** Retrieve parts bag (1) labeled with MD #368323. From that bag, retrieve the parts listed in Table 5.11, page 176.

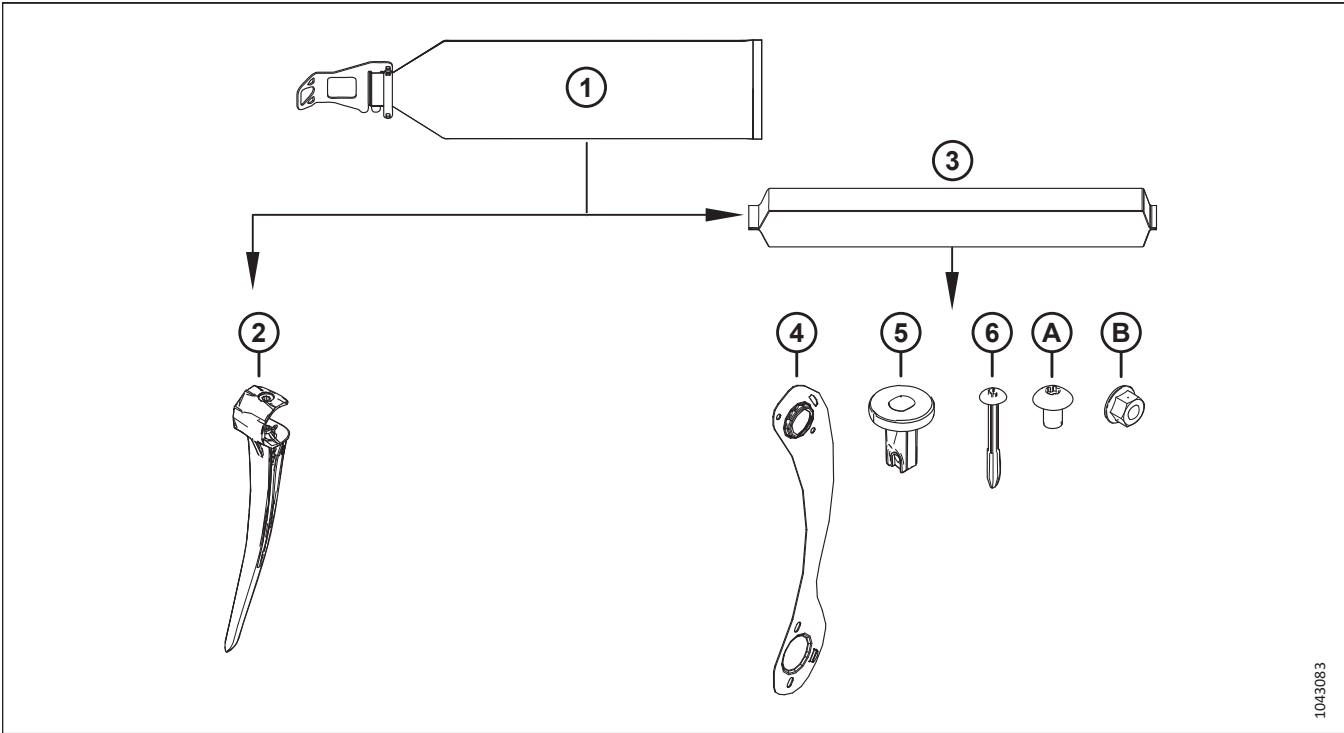

Figure 5.112: Six-Bat Reel Endshield Parts Bag MD #368323

Table 5.11 Parts to Retrieve from Six-Bat Reel Endshields Parts Bag MD #368323

Ref	Part Number	Description	Quantity
2	NSS see notes ⁸⁹	FINGER – PLASTIC – LH ANGLED 45MM	6
3	368334 (“RH”)	ENDSHLD BAG – 6 BAT RH IB TAIL NOTE: This bag contains the parts listed below.	1
4	311822	SHIELD – 6 BAT RH REEL-TAIL END	6
5	273968	BUSHING – ENDSHIELD	6
6	252687	SCREW – 48° PLASTITE TWIN HELIX	6
A	136640	SCR – TORX TRUSS HD M10X1.5X16XSPCL-8.8-AA1J	12
B	135799	NUT – HEX FLG CTR LOC M10X1.5-10	12

8. Not sold separately. For service parts, can be ordered as a package of 10 (MD #360540).
 9. These parts are marked with a black cable tie to indicate that they belong with parts bag (3) (“RH IB TAIL”, MD #368334) which should also be marked with a black cable tie.

COMPLETING HEADER ASSEMBLY

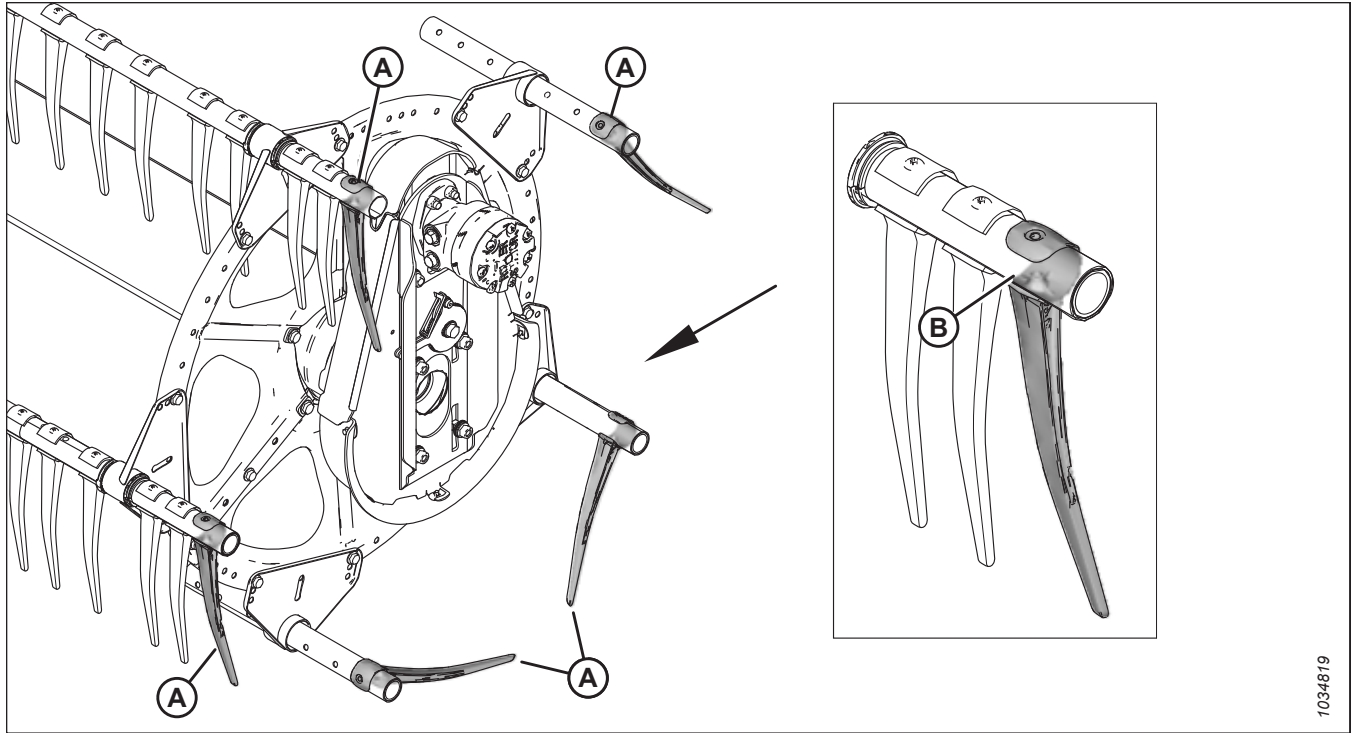
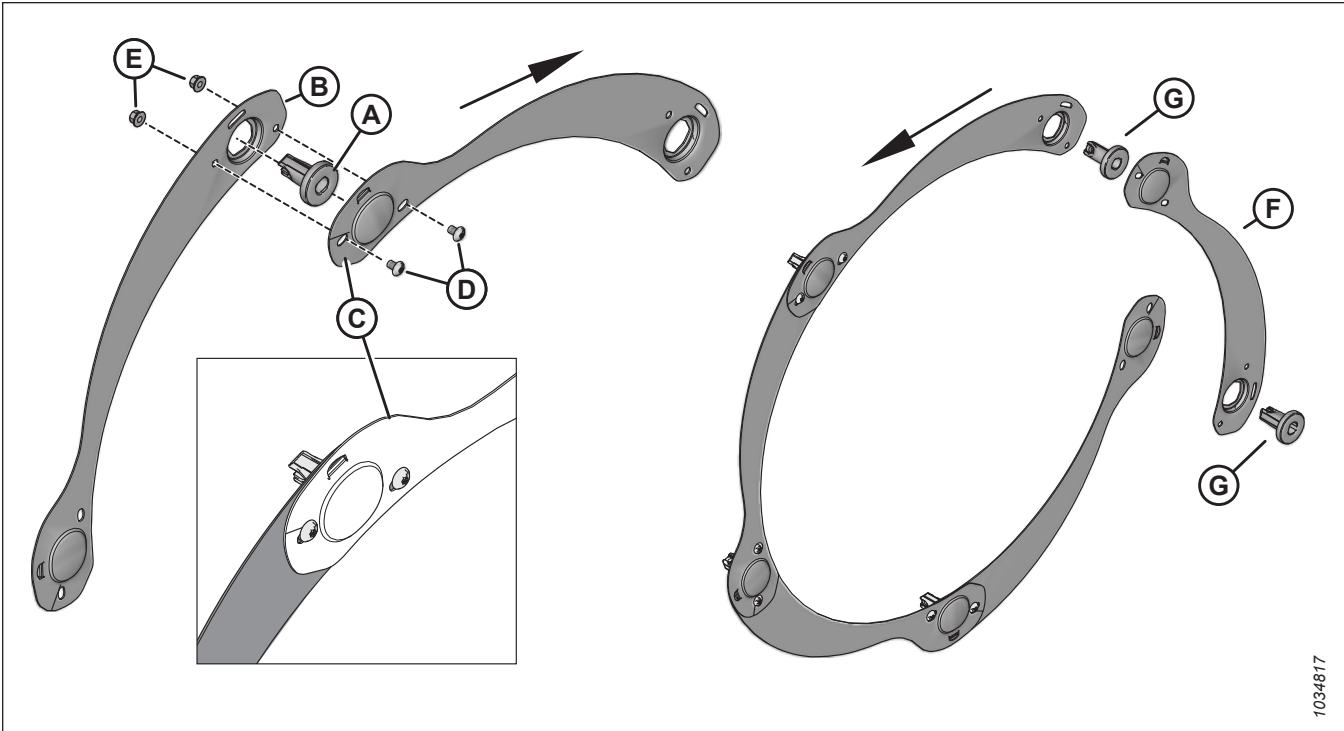

Figure 5.113: Fingers Placed on Tine Tubes

4. Place one finger (A) onto each tine tube. Ensure that open face (B) of each finger faces the front of the header.

COMPLETING HEADER ASSEMBLY



1034817

Figure 5.114: Endshield Subassembly

5. Assemble the endshield as follows:
 - a. Insert bushing (A) into endshield segment (B).
 - b. Place the cupped end of endshield segment (C) on top of segment (B). Secure the segments using two M10 X 1.5 X 16 Torx® screws (D) and nuts (E). Do **NOT** tighten the hardware yet.
 - c. Repeat Substep (a.) and Substep (b.) to install the remaining segments. Do **NOT** install last segment (F) and two bushings (G) yet.

COMPLETING HEADER ASSEMBLY

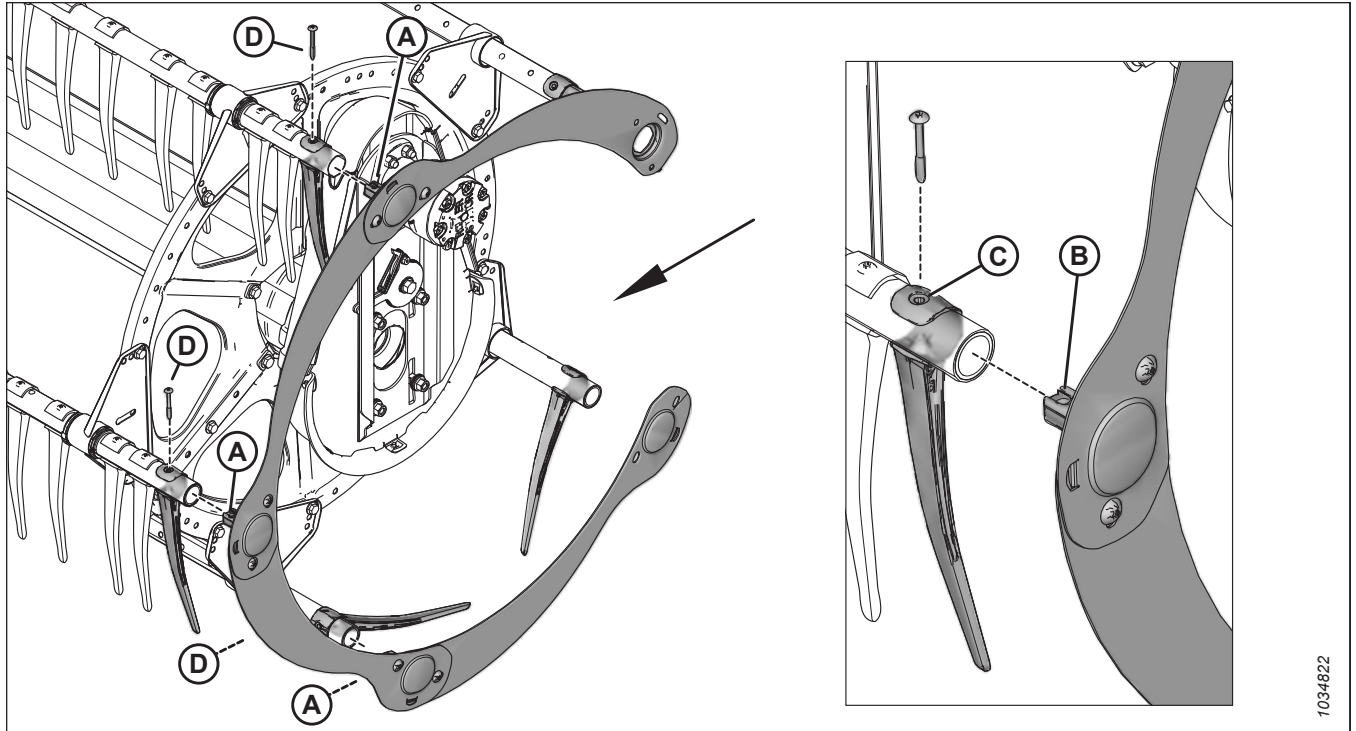

Figure 5.115: Endshield Mounted onto Reel

6. Mount the endshield onto the reel as follows:
 - a. Insert three bushings (A) into the tine tubes. Align the holes in bushing (B) and finger (C) with the hole in the tine tube.
 - b. Secure the bushings and the fingers using Torx® Plastite® screws (D). Do **NOT** tighten the hardware yet.

COMPLETING HEADER ASSEMBLY

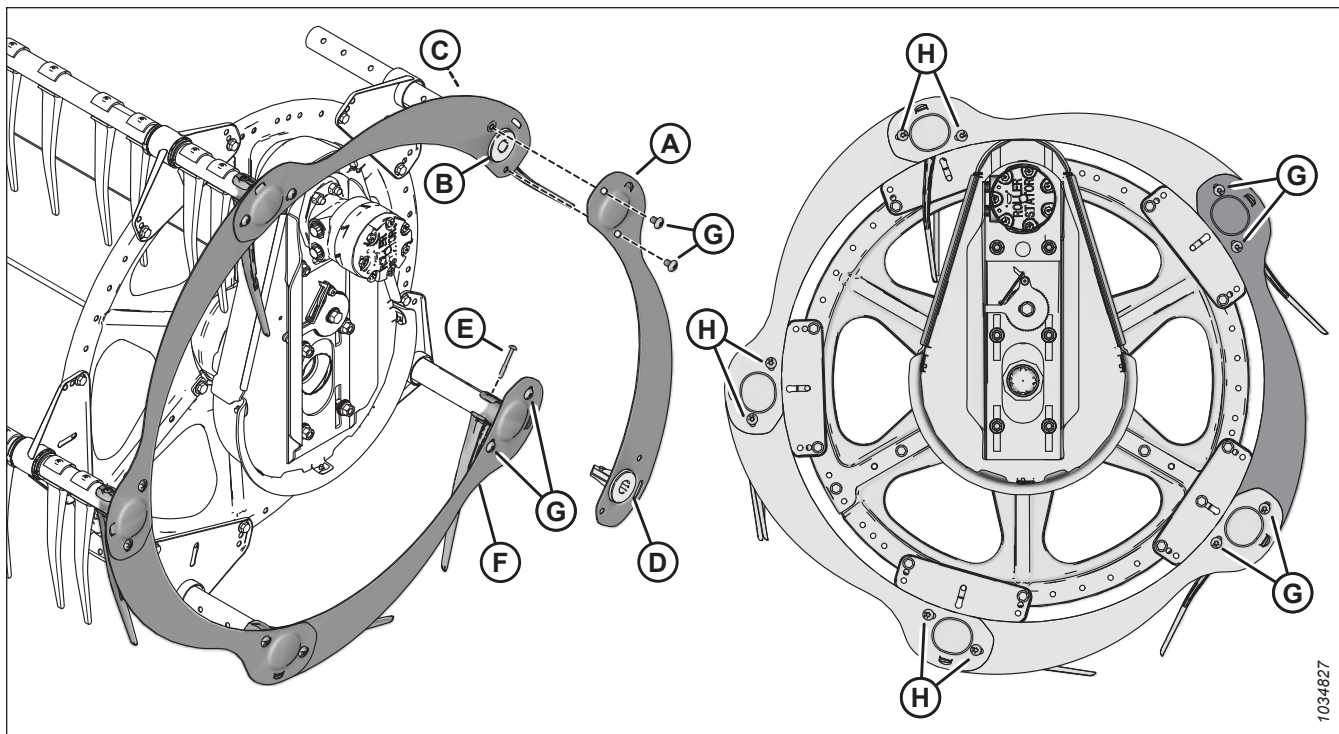

Figure 5.116: Completed Endshield Assembly

7. Install remaining endshield segment (A) as follows:
 - a. Install bushing (B) into the endshield segment and the tine tube. Secure the bushing with Torx® Plastite® screw (C). Do **NOT** tighten the hardware yet.
 - b. Install bushing (D) into the endshield segment.
 - c. Insert the end of the segment with bushing (D) into the tine tube. Secure it with Torx® Plastite® screw (E). Do **NOT** tighten the hardware yet.
 - d. Place the cupped end of segment (F) on top of segment (A).
 - e. Secure the endshield segments with M10 X 1.5 X 16 Torx® screws and nuts (G).
8. Tighten all the tine tube finger Torx® Plastite® screws to 9 Nm (80 lbf in). Do **NOT** overtighten the screws; overtightening will flatten the tubes.
9. Torque all M10 X 1.5 X16 Torx® screws (G) and (H) to 39 Nm (29 lbf-ft).

5.19.3 Installing Double-Reel Endshields at Inboard Cam End

Endshields need to be installed at the cam end of the left reel to prevent crop from wrapping around the reel.

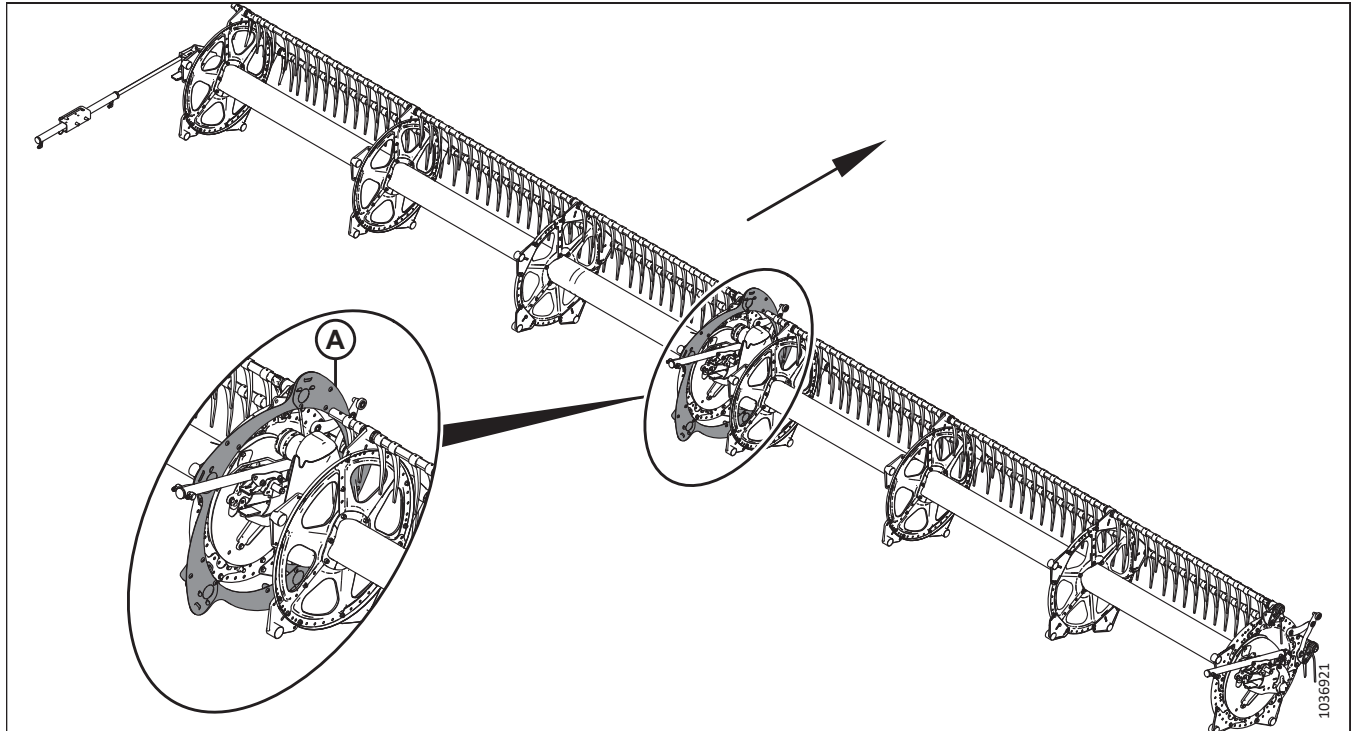

Figure 5.117: Five-Bat Double Reel

NOTE:

Inboard cam-end endshields (A) are installed on the right of the reel.

NOTE:

The arrow in the illustration in this procedure indicate the front of the header.

NOTE:

The illustrations in this procedure all show five-bat reel endshields. The procedure for installing six-bat endshields is the same, only the quantity of parts is different.

1. If not already done at least once, raise the reel fully, and then lower it fully.

IMPORTANT:

Raising the reel fully, and then lowering it fully, will fill the hydraulic lines with oil and will purge them of air. Doing this before installing the inboard endshields will prevent the inboard endshields from contacting and damaging each other when the reel is subsequently raised.

COMPLETING HEADER ASSEMBLY

2. **Five-bat reels:** Retrieve parts bag (1) labeled with MD #368322. From that bag, retrieve the parts listed in Table 5.12, page 182.

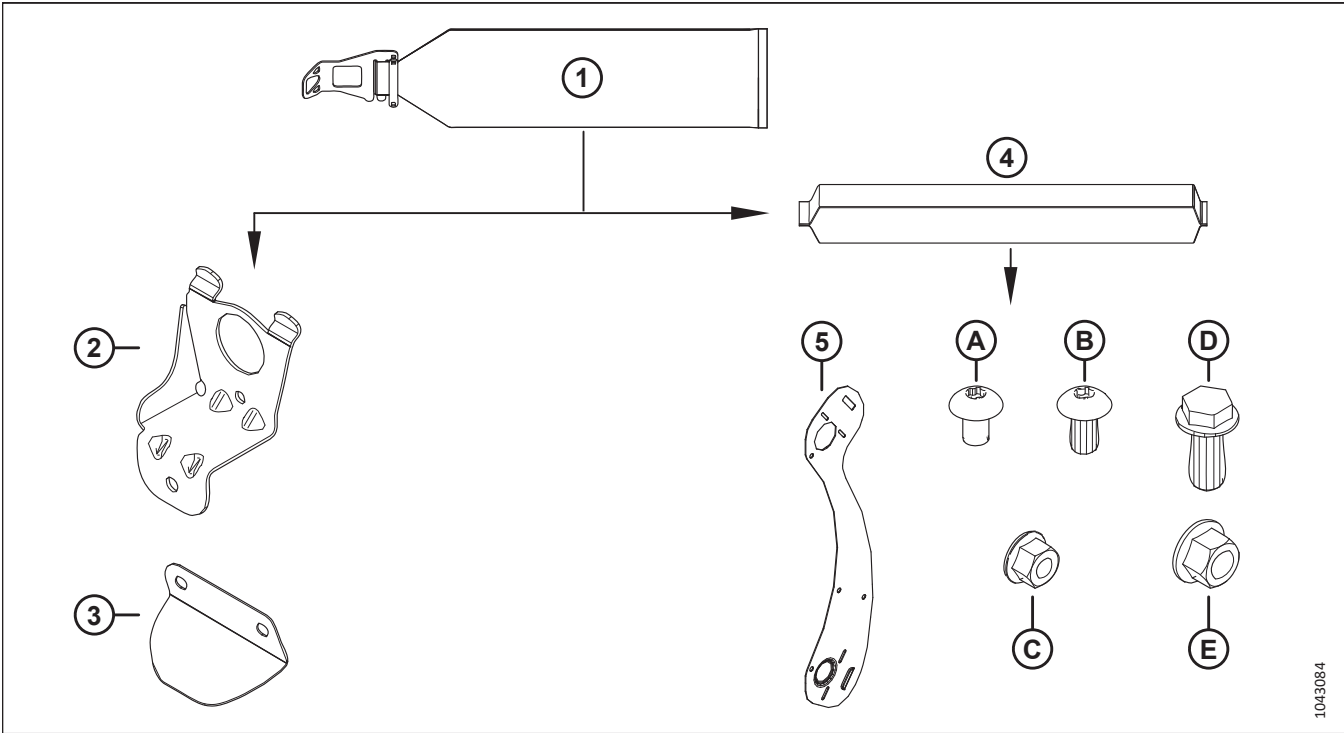

Figure 5.118: Reel Endshield Parts Bag MD #368322

Table 5.12 Parts to Retrieve from Five-Bat Reel Endshields Parts Bag MD #368322

Ref	Part Number	Description	Quantity
2	311964 - see note ¹⁰	SUPPORT – CAM END	5
3	311906 – see note ¹⁰	DEFLECTOR – CAM INBOARD	5
4	368330 (“LH CAM”)	ENDSHLD BAG – 5 BAT LH IB CAM NOTE: This bag contains the parts listed below.	1
5	273823	SHIELD – 5 BAT LH REEL CAM END	5
A	136640	SCR – TORX TRUSS HD M10X1.5X16XSPCL-8.8-AA1J	10
B	136395	SCR – TORX TRUSS HD M10X1.5X20XSPCL-8.8-A3L	5
C	135799	NUT – HEX FLG CTR LOC M10X1.5-10	15
D	320180	BOLT – HEX FLG HD M12X1.75X30-SPCL-8.8-ZINC	5
E	136431	NUT – HEX FLG CTR LOC M12X1.75-10	5

10. These parts are marked with a green cable tie to indicate that they belong with parts bag (4) (“LH CAM”, MD #368330) which should also be marked with a green cable tie.

COMPLETING HEADER ASSEMBLY

3. **Six-bat reels:** Retrieve parts bag (1) labeled with MD #368323. From that bag, retrieve the parts listed in Table 5.13, page 183.

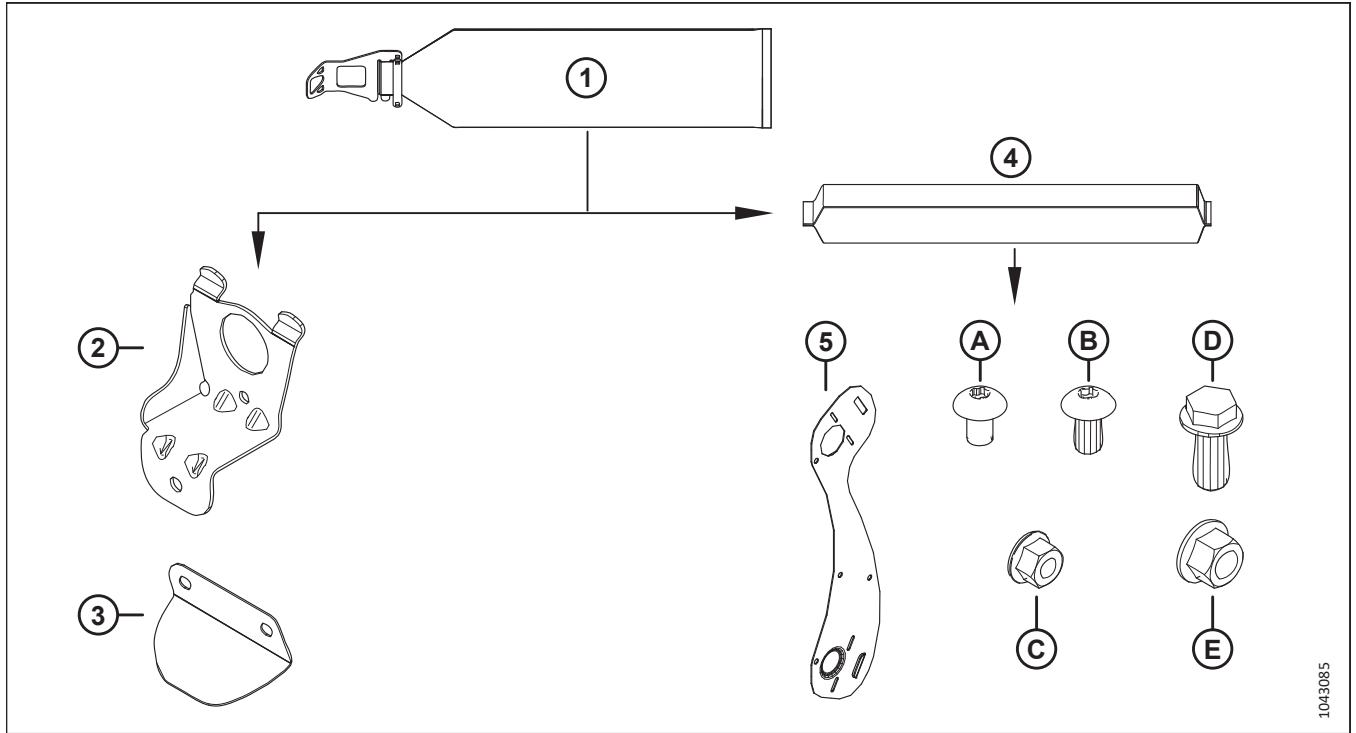

Figure 5.119: Six-Bat Reel Endshield Parts Bag MD #368323

Table 5.13 Parts to Retrieve from Six-Bat Reel Endshields Parts Bag MD #368323

Ref	Part Number	Description	Quantity
2	311964 - see note ¹¹	SUPPORT – CAM END	6
3	311906 - see note ¹¹	DEFLECTOR – CAM INBOARD	6
4	368341 (“LH”)	ENDSHLD BAG – 6 BAT LH IB CAM NOTE: This bag contains the parts listed below.	1
5	273813	SHIELD – 6 BAT LH REEL CAM END	6
A	136640	SCR – TORX TRUSS HD M10X1.5X16XSPCL-8.8-AA1J	12
B	136395	SCR – TORX TRUSS HD M10X1.5X20XSPCL-8.8-A3L	6
C	135799	NUT – HEX FLG CTR LOC M10X1.5-10	18
D	320180	BOLT – HEX FLG HD M12X1.75X30-SPCL-8.8-ZINC	6
E	136431	NUT – HEX FLG CTR LOC M12X1.75-10	6

11. These parts are marked with a green cable tie to indicate that they belong with parts bag (4) (“LH CAM”, MD #368341) which should also be marked with a green cable tie.

COMPLETING HEADER ASSEMBLY

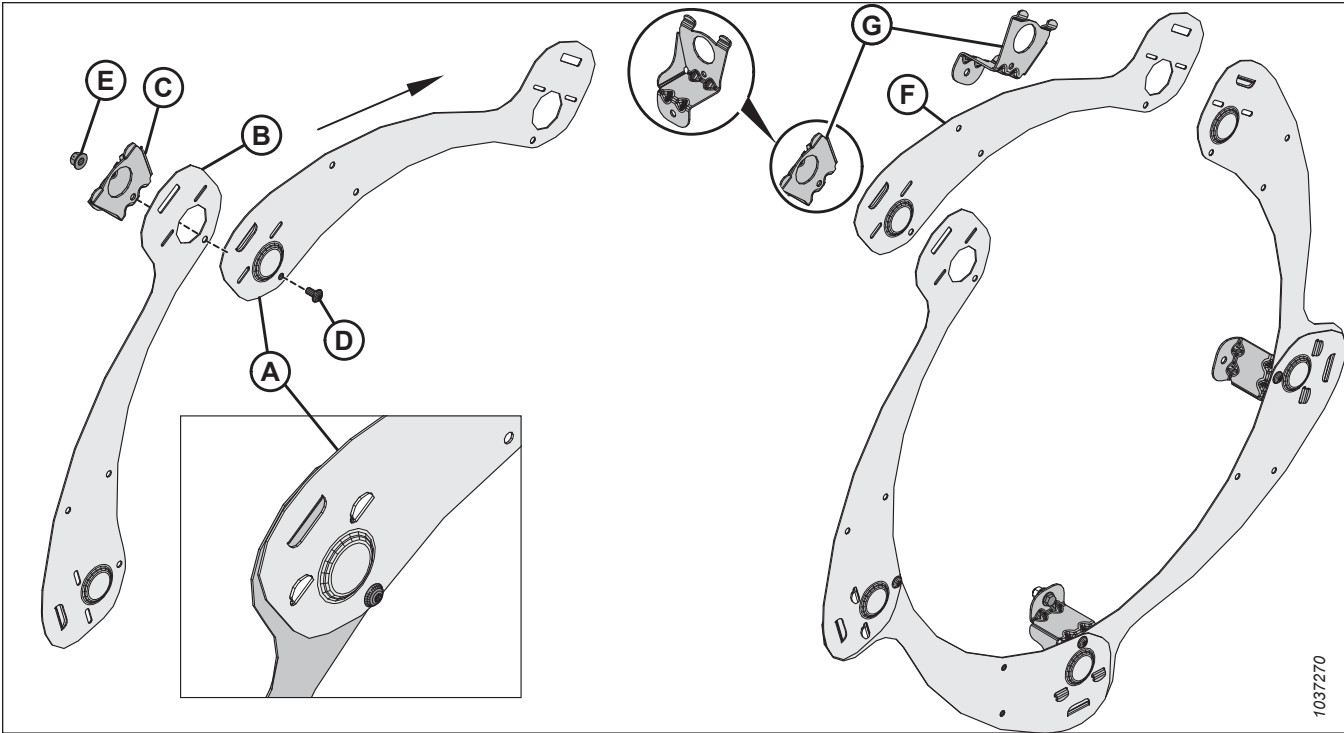

Figure 5.120: Five-Bat Reel – Initial Endshield Assembly

4. Assemble the endshield as follows:

- a. Position endshield segment (A) behind segment (B). Engage endshield support tabs (C) through both segments. Secure the segment with M10 X 1.5 X 20 Torx® screw (D) and hex nut (E). Do **NOT** tighten the hardware yet.
- b. Repeat the previous step to install the remaining segments. Do **NOT** install last segment (F) and two support tabs (G) yet.

COMPLETING HEADER ASSEMBLY

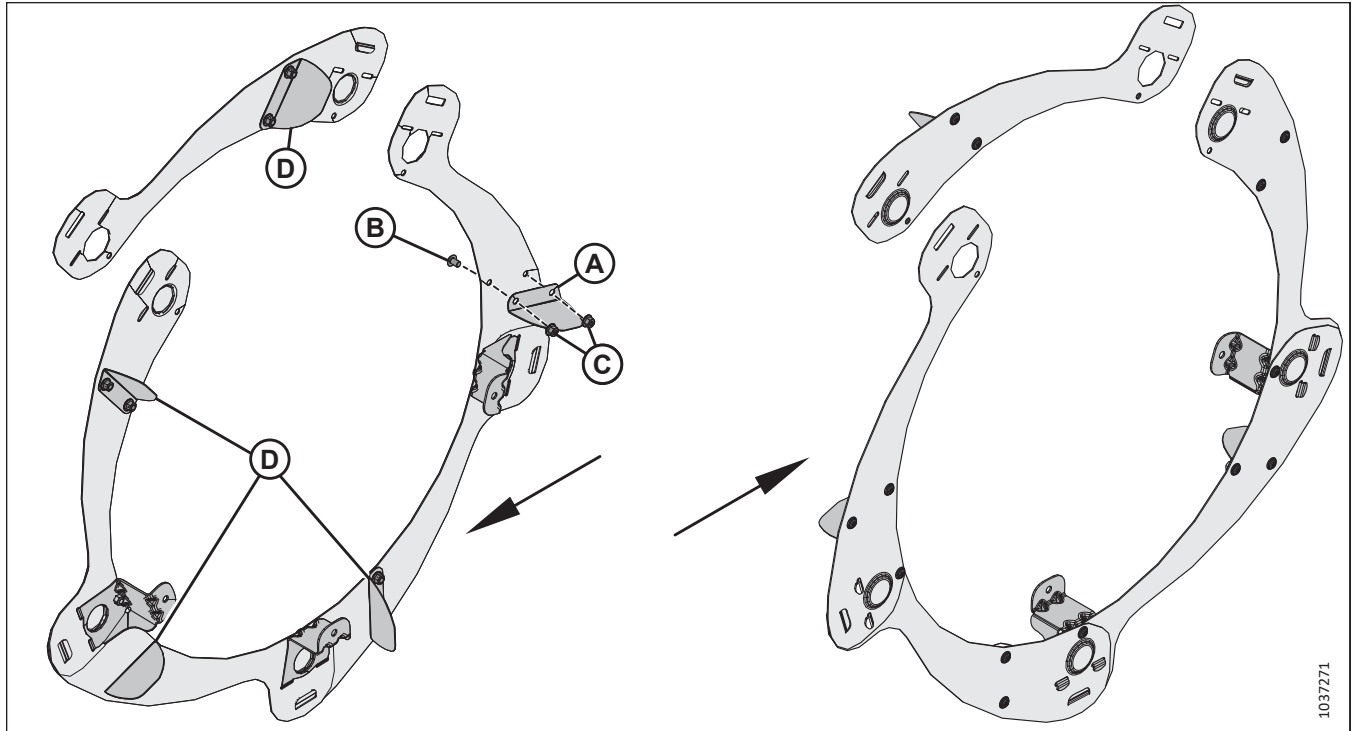

Figure 5.121: Five-Bat Reel – Aluminum Cam Deflectors

5. Install four aluminum cam deflectors (A) (MD #311906) on the inboard face of the endshield assembly using two M10 X 1.5 X 16 Torx® screws (B) and hex nuts (C).
6. Install aluminum cam deflector (D) (MD #311906) on the last segment as shown using two M10 X 1.5 X 16 Torx® screws and hex nuts.

COMPLETING HEADER ASSEMBLY

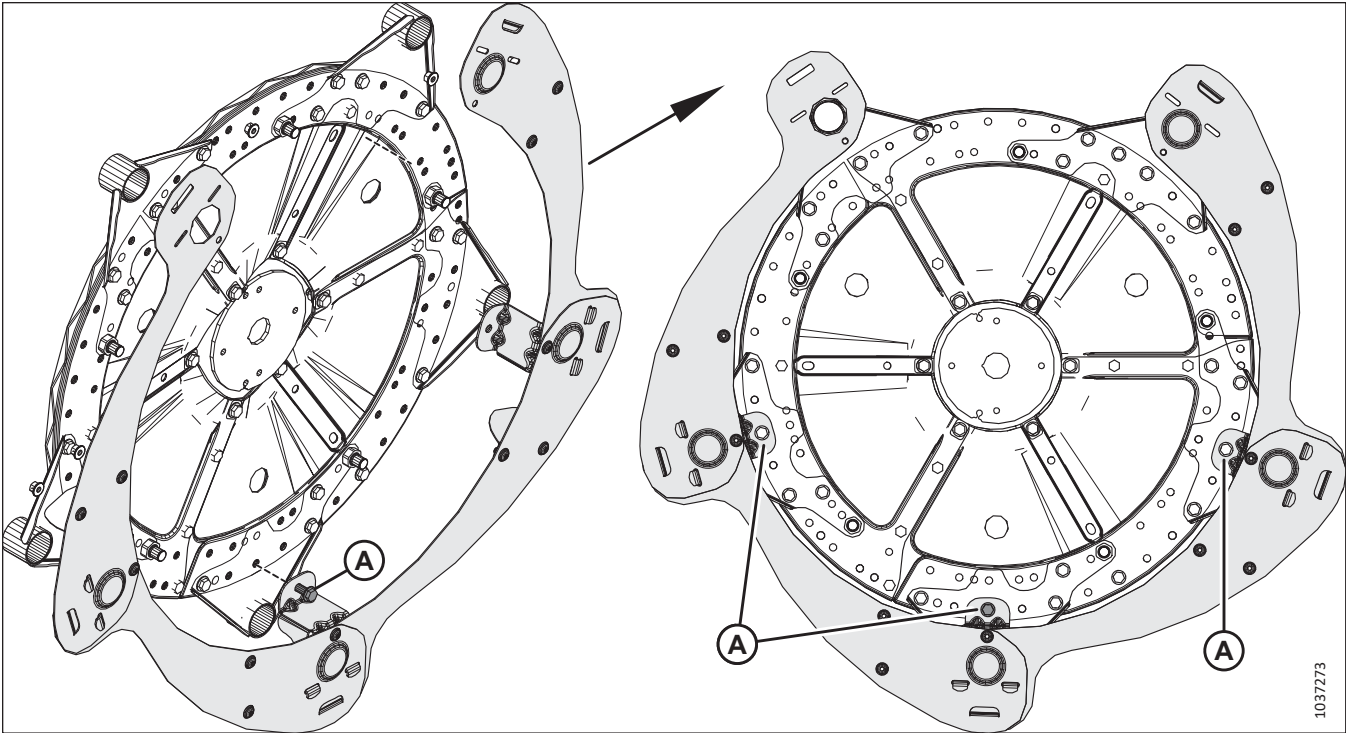

Figure 5.122: Five-Bat Reel – Partially Assembled Reel Endshields on Reel

7. Position the partially assembled reel endshield on the reel.
8. Secure the endshield with three M12 X 1.75 X 30 hex bolts (A) and nuts. Do **NOT** tighten the hardware yet.

COMPLETING HEADER ASSEMBLY

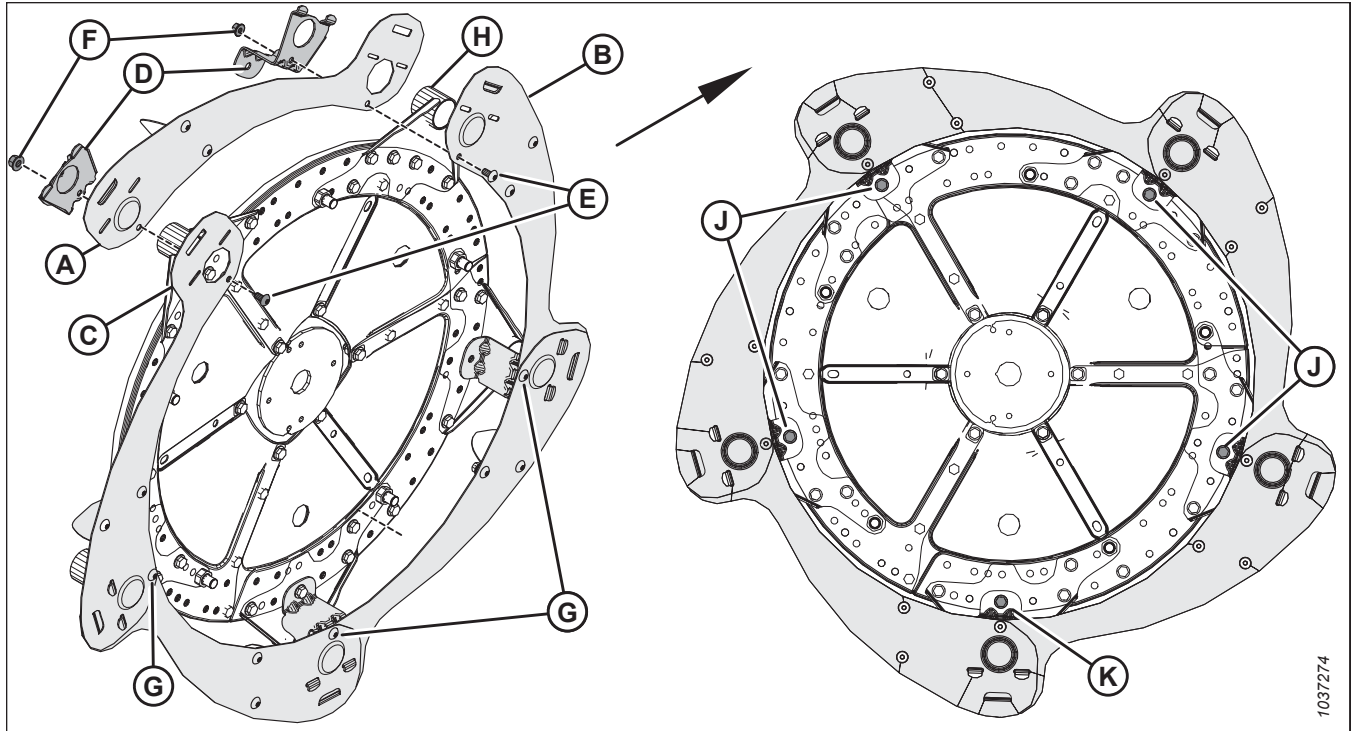

Figure 5.123: Five-Bat Reel – Assembled Reel Endshields on Reel

9. Install the last segment of endshield (A) as follows:
 - a. Position the wide end of last segment (A) behind segment (B). Position the other end of last segment on top of segment (C).
 - b. Insert the tabs of endshield supports (D) through the endshield segments.
 - c. Secure the endshield supports using two M10 X 1.5 X 20 Torx® screws (E) and nuts (F).
 - d. Torque five M10 X 1.5 X 20 Torx® screws (E) and (G) to 39 Nm (29 lbf-ft). Rotate the reel to reach the screws if necessary.

10. Slip endshield supports onto tine tubes (H).

NOTE:

Not all of the tine tubes are shown in the illustration.

11. Secure the remaining endshield supports to the reel disc using one M12 X 1.75 X 30 hex bolts (J) and nut per endshield support.
12. Torque M12 X 1.75 X 30 hex bolts (J) and (K) and the nuts that secure the endshield supports to the cam discs to 69 Nm (51 lbf-ft).

5.19.4 Installing Double-Reel Endshields at Outboard Tail End

Endshields need to be installed on the tail end of the left reel to prevent crop from wrapping around the reel.

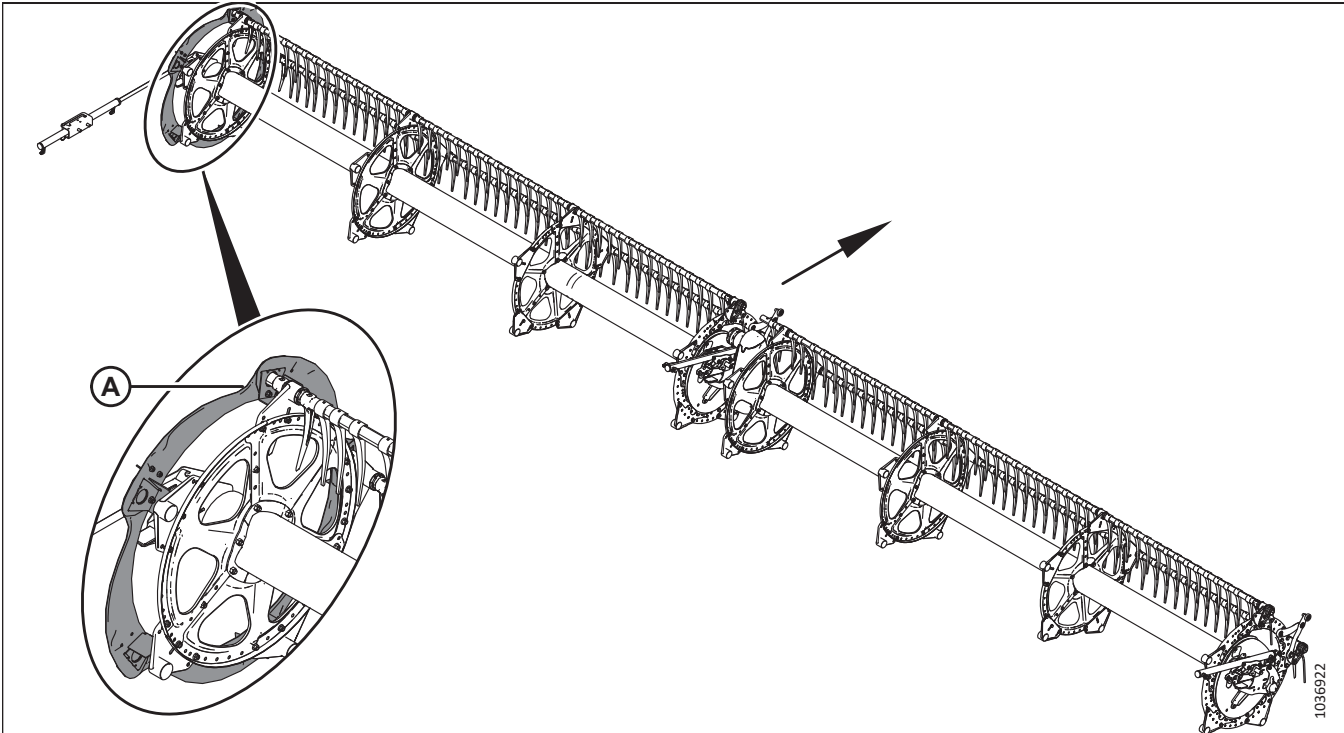

Figure 5.124: Five-Bat Double Reel

NOTE:

Outboard tail-end endshields (A) are installed on the left of the reel.

NOTE:

The arrow in the illustrations indicates the front of the header.

NOTE:

This procedure applies to five-bat reels. The procedure for six-bat reels is similar.

COMPLETING HEADER ASSEMBLY

1. **Five-bat reels:** Retrieve parts bag (1) labeled with MD #368322. From that bag, retrieve the parts listed in Table 5.14, page 189.

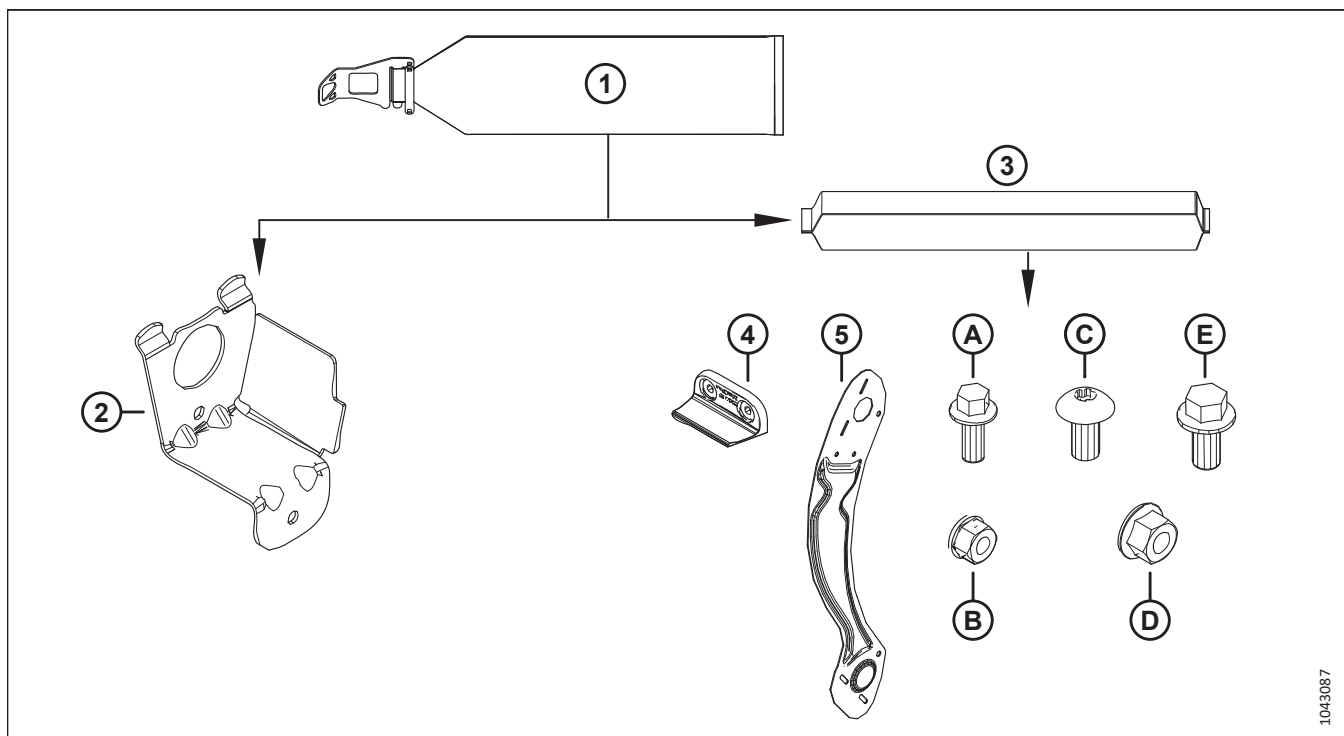

Figure 5.125: Five-Bat Reel Endshield Parts Bag MD #368322

Table 5.14 Parts to Retrieve from Five-Bat Reel Endshields Parts Bag (MD #368322)

Ref	Part Number	Description	Quantity
2	311965 – see note ¹²	SUPPORT – TAIL END	5
3	368329 (“LH”)	ENDSHLD BAG – 5 BAT LH OB TAIL NOTE: This bag contains the parts listed below.	1
4	313035	PADDLE – REEL END; HYTREL	3
5	311695	SHIELD – OUTBOARD LH 5 BAT	5
A	136300	BOLT – HEX FLG HD TFL M8X1.25X20-8.8-AA3L	6
B	135337	NUT – HEX FLG CTR LK M8X1.25-8-AA1J	6
C	136395	SCR – TORX TRUSS HD M10X1.5X20SPCL-8.8-A3L	5
D	135799	NUT – HEX FLG CTR LOC M10X1.5-10	10
E	152655	BOLT – HEX FLG HD M10X1.5X20-8.8-AA1J	5

12. These parts are marked with a yellow cable tie to indicate that they belong with parts bag (3) (“LH”, MD #368329) which should also be marked with a yellow cable tie.

COMPLETING HEADER ASSEMBLY

2. **Six-bat reels:** Retrieve parts bag (1) labeled with MD #368323. From that bag, retrieve the parts listed in Table 5.15, page 190.

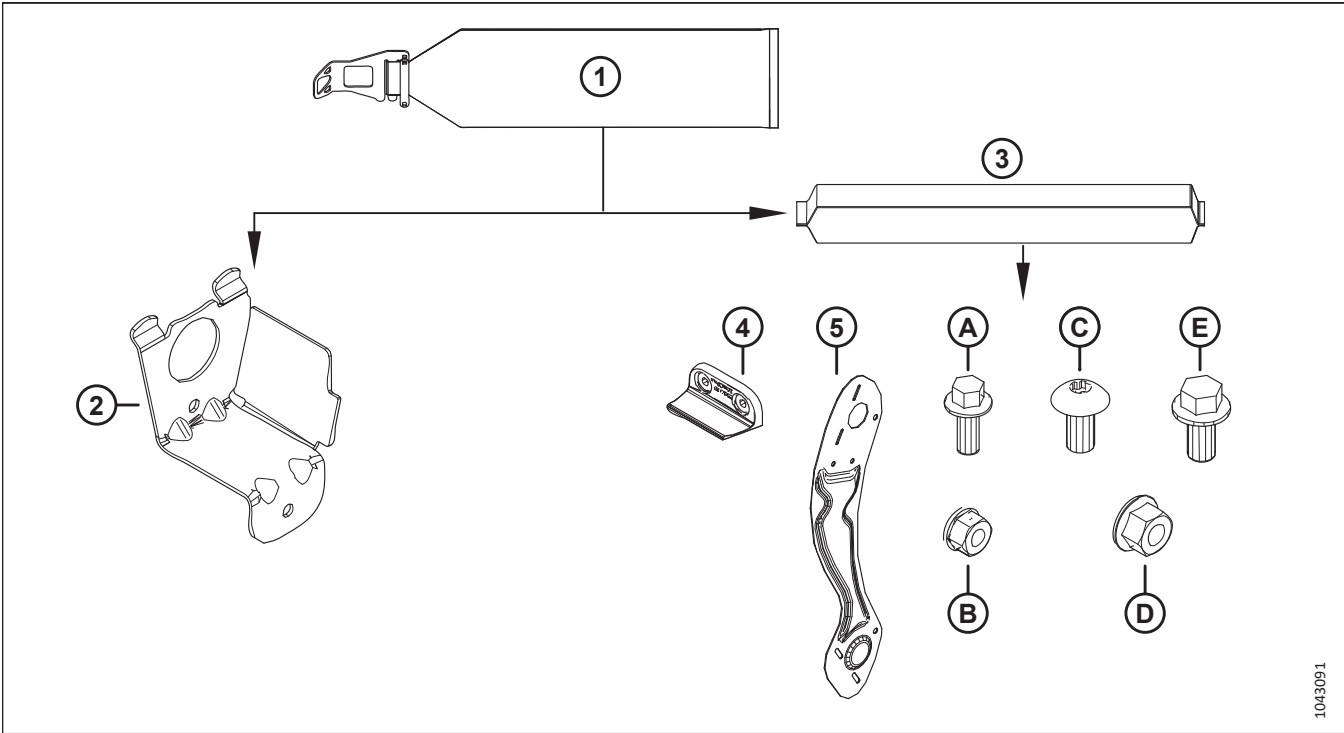

Figure 5.126: Six-Bat Reel Endshield Parts Bag MD #368323

Table 5.15 Parts to Retrieve from Six-Bat Reel Endshields Parts Bag (MD #368323)

Ref	Part Number	Description	Quantity
2	311965 – see note ¹³	SUPPORT – TAIL END	6
3	368333 (“LH”)	ENDSHLD BAG – 6 BAT LH OB TAIL NOTE: This bag contains the parts listed below.	1
4	313035	PADDLE – REEL END; HYTREL	3
5	311753	SHIELD – OUTBOARD LH 6 BAT	6
A	136300	BOLT – HEX FLG HD TFL M8X1.25X20-8.8-AA3L	6
B	135337	NUT – HEX FLG CTR LK M8X1.25-8-AA1J	6
C	136395	SCR – TORX TRUSS HD M10X1.5X20SPCL-8.8-A3L	6
D	135799	NUT – HEX FLG CTR LOC M10X1.5-10	12
E	152655	BOLT – HEX FLG HD M10X1.5X20-8.8-AA1J	6

13. These parts are marked with a yellow cable tie to indicate that they belong with parts bag (3) (“LH”, MD #368333) which should also be marked with a yellow cable tie.

COMPLETING HEADER ASSEMBLY

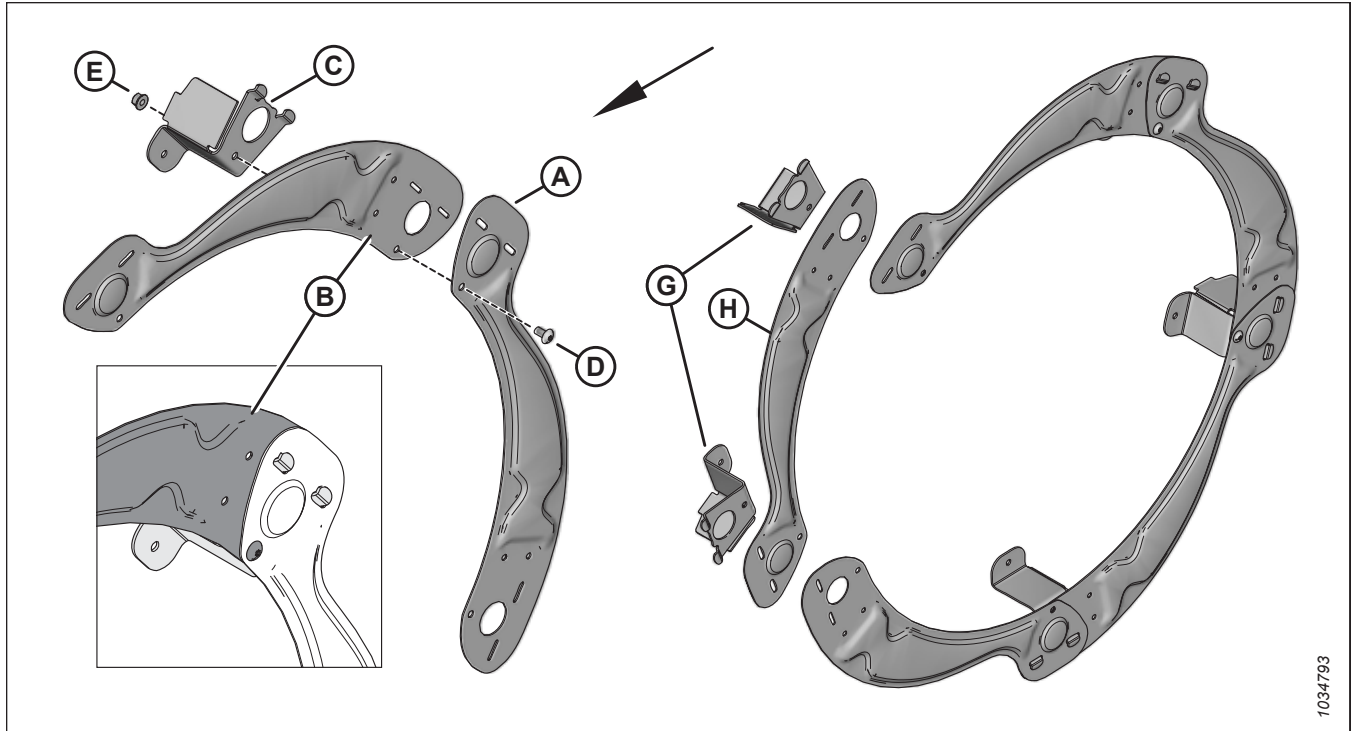

Figure 5.127: Five-Bat Reel – Initial Endshield Assembly

3. Assemble the endshield as follows:

- a. Position endshield segment (A) in front of segment (B). Engage endshield support tabs (C) through both segments. Secure the segments with M10 X 1.5 X 20 Torx® screw (D) and hex nut (E). Do **NOT** tighten the hardware yet.
- b. Repeat the previous step to assemble the remaining segments. Do **NOT** install last segment (H) and two support tabs (G) yet.

COMPLETING HEADER ASSEMBLY

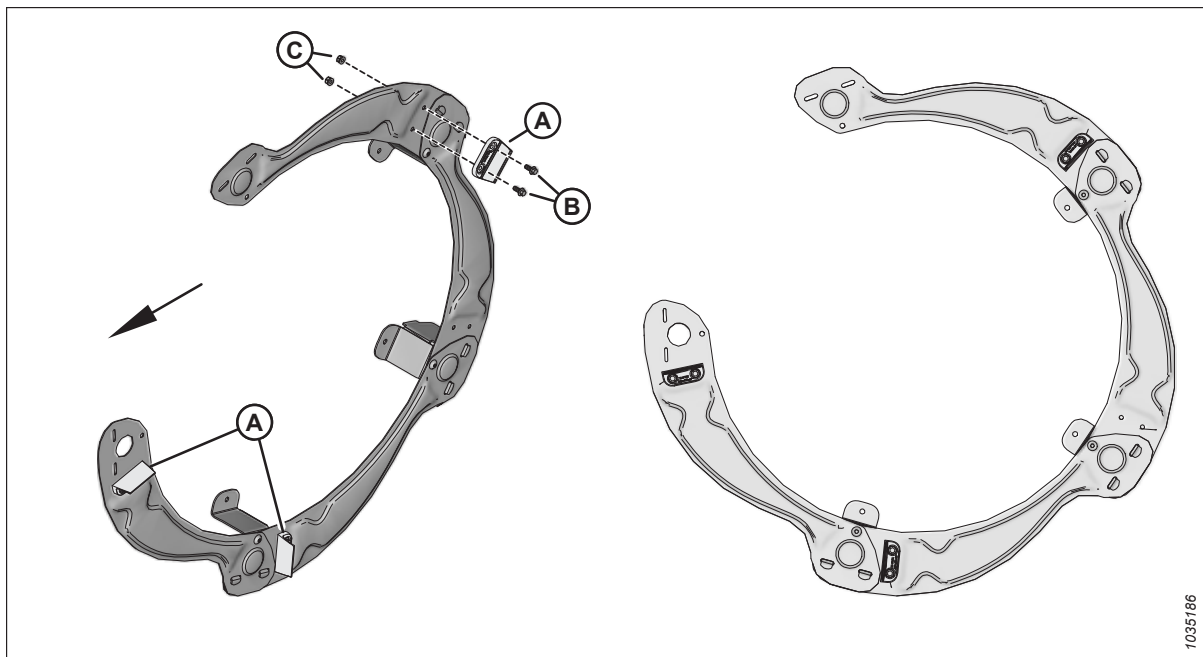

Figure 5.128: Five-Bat Reel – Rubber Paddles

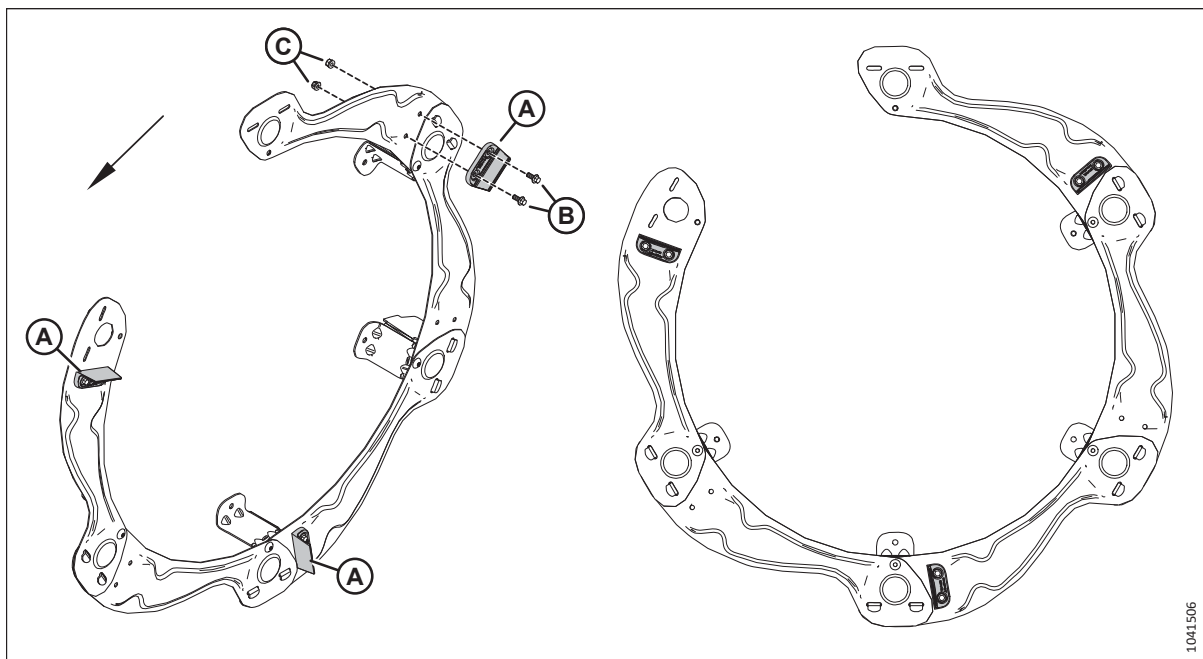

Figure 5.129: Six-Bat Reel – Rubber Paddles

NOTE:

For five-bat reels, refer to Figure 5.128, page 192. For six-bat reels, refer to Figure 5.129, page 192.

4. Install three rubber reel end paddles (A) on the outboard face of the endshield assembly using two M8 X 1.25 X 20 hex bolts (B) and nuts (C) per paddle.

IMPORTANT:

Ensure that the rubber paddles are oriented as shown. The rubber paddles on both ends of the reel (the outboard cam and outboard tail ends) should be aligned.

COMPLETING HEADER ASSEMBLY

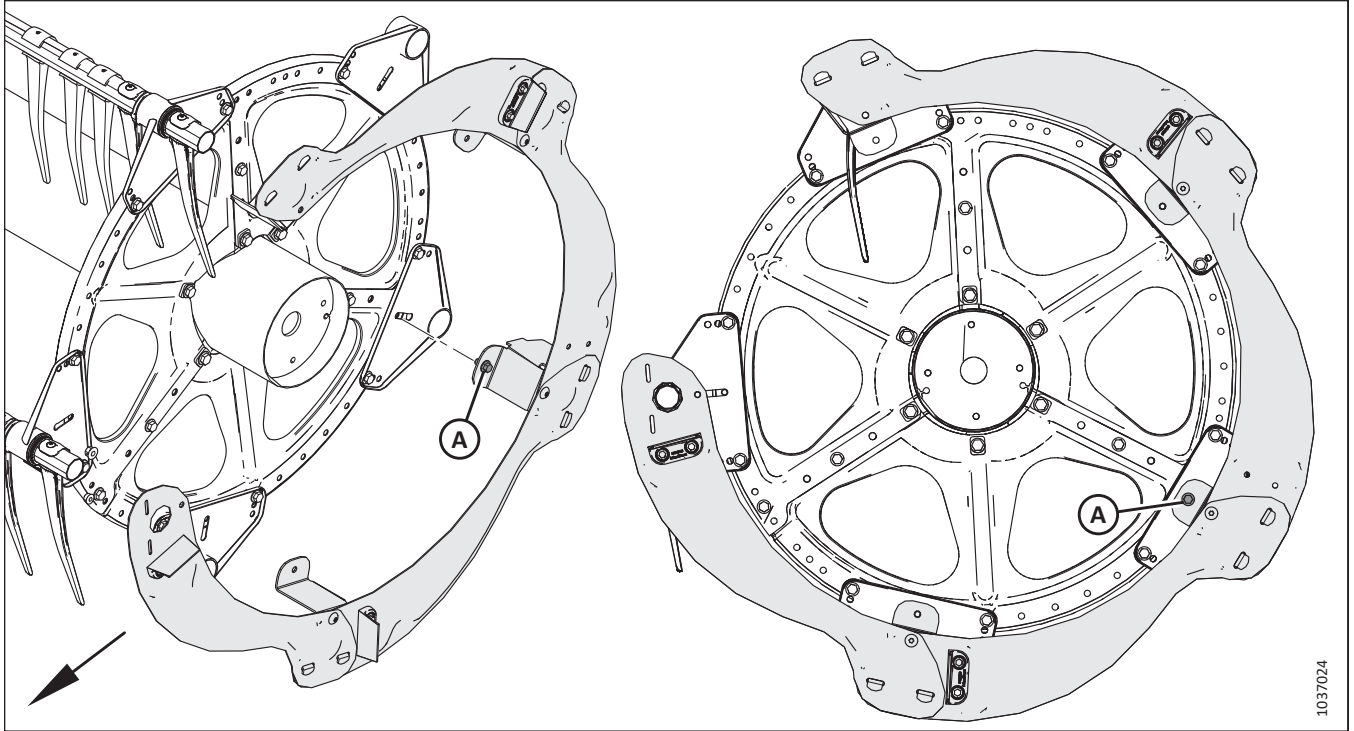

Figure 5.130: Five-Bat Reel – Partially Assembled Reel Endshields on Reel

5. Position the partially assembled reel endshield on the reel and tine tubes.
6. Identify the endshield support tab opposite the opening in the circle of endshield segments. Secure that support tab to the reel with one M10 X 1.5 X 20 hex bolt (A) and nut. Do **NOT** tighten the hardware yet.

COMPLETING HEADER ASSEMBLY

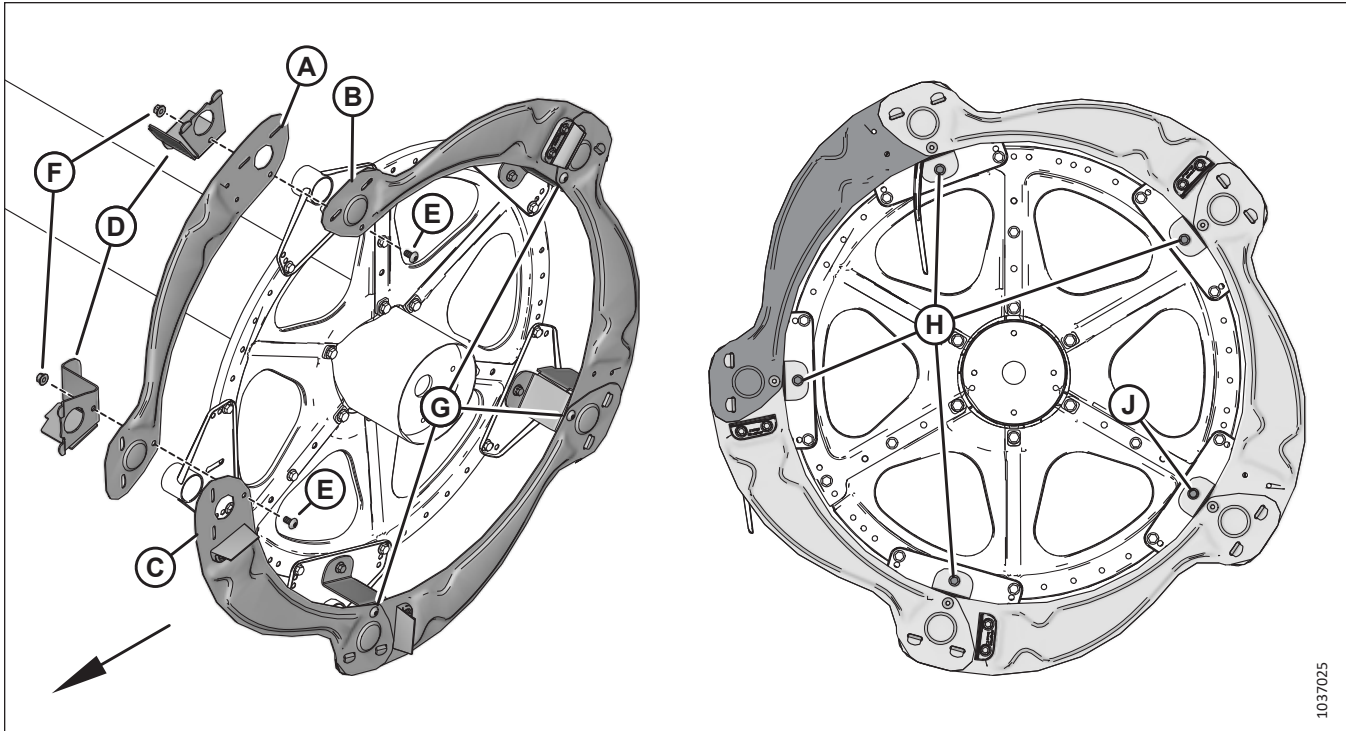

Figure 5.131: Five-Bat Reel – Partially Assembled Reel Endshields on Reel

7. Install the last segment of endshield (A) as follows:
 - a. Position the wide end of last segment (A) behind segment (B). Position the other end of last segment on top of segment (C).
 - b. Insert the tabs of endshield supports (D) through the endshield segments.
 - c. Secure the endshield supports using two M10 X 1.5 X 20 Torx® screws (E) and nuts (F).
 - d. Torque M10 X 1.5 X 20 Torx® screws (E) and (G) to 39 Nm (29 lbf-ft). Rotate the reel to reach the screws if necessary.
8. Secure the endshield supports to the reel disc using one M10 X 1.5 X 20 hex bolt and nut (H) per endshield support.
9. Torque M10 X 1.5 X 20 hex bolts (H) and (J) and the nuts that secure the endshield supports to the cam discs to 39 Nm (29 lbf-ft).

5.20 Installing Tank Covers (Parts Bag MD #357088)

The tank covers protect the float module's hydraulic fluid tank. They will need to be removed from their shipping position and installed on the float module.

1. Remove and discard banding (A) and blocks (B) from the back of the feed auger.
2. Retrieve left and right covers (C) and parts bag MD #357088.

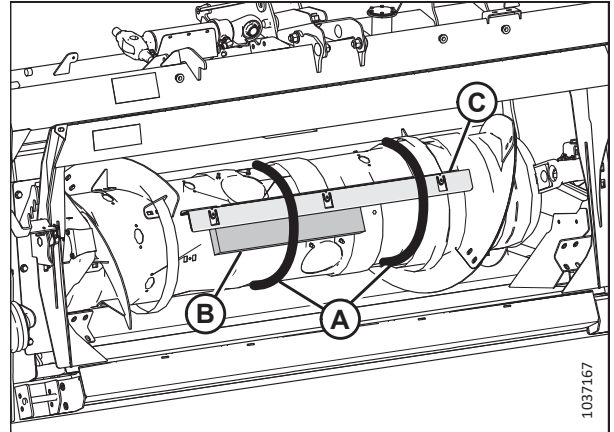

Figure 5.132: Tanks Covers Secured to Float Module's Feed Auger

3. Install covers (A) and (B) on the front of the float module. Secure the covers with push-in clips (C).

NOTE:

You may need to slightly bend the tabs on the tank covers to get them to slot in.

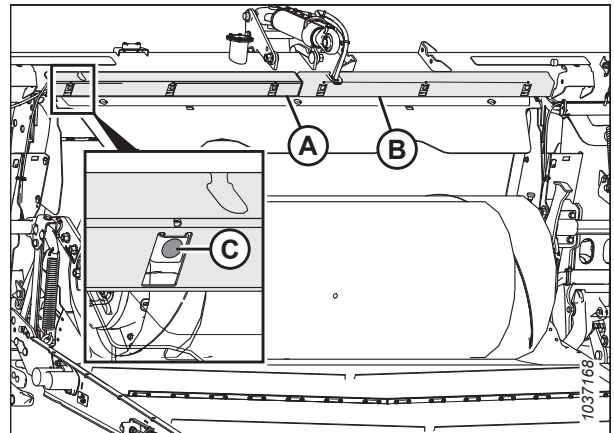

Figure 5.133: Tank Covers Installed on Float Module

5.21 Installing Clearance Lights

Clearance lights are used when transporting the header. They are secured to the sides of the reel arms for shipping purposes and must be repositioned for field use.

DANGER

To prevent bodily injury or death from the unexpected start-up of the machine, always stop the engine and remove the key from the ignition before making adjustments to the machine.

1. Shut down the engine, and remove the key from the ignition.
2. Retrieve previously removed left clearance light assembly (A).
3. Remove two M10 locking flange nuts (C) and two M10 X 1.5 X 35 mm bolts (B).

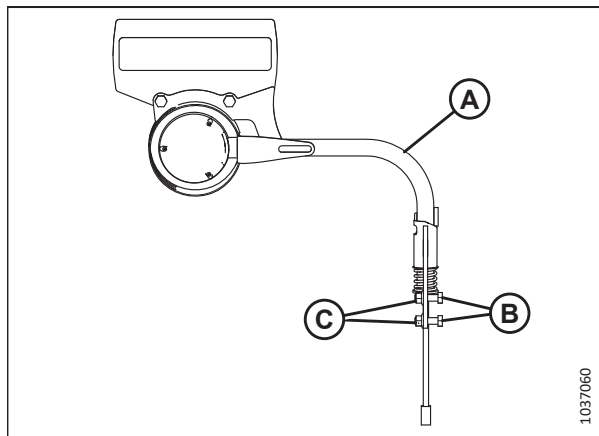

Figure 5.134: Left Clearance Light

4. Position left clearance light assembly (A) on the outboard side of the left reel arm support.
5. Secure left clearance light assembly (A) to the left reel arm support with two M10 X 1.5 X 35 mm bolts (B) and two M10 locking flange nuts (C).
6. Connect electrical harness (D) to the header harness.

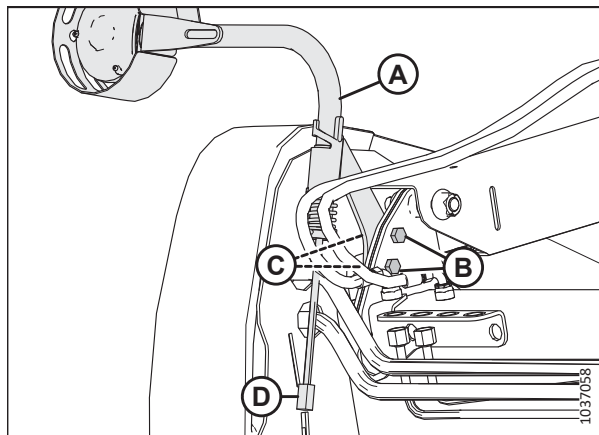

Figure 5.135: Left Clearance Light

COMPLETING HEADER ASSEMBLY

7. Retrieve previously removed right clearance light assembly (A).
8. Remove two M10 locking flange nuts (C) and M10 X 1.5 X 35 mm bolts (B).

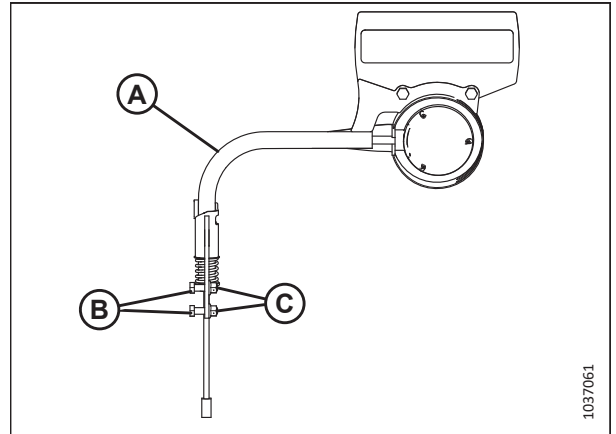

Figure 5.136: Right Clearance Light

9. Position right clearance light assembly (A) on the outboard side of the right reel arm support.
10. Secure right clearance light assembly (A) to the right reel arm support with two M10 X 1.5 X 35 mm bolts (B) and two M10 locking flange nuts (C).
11. Connect electrical harness (D) to the header harness.

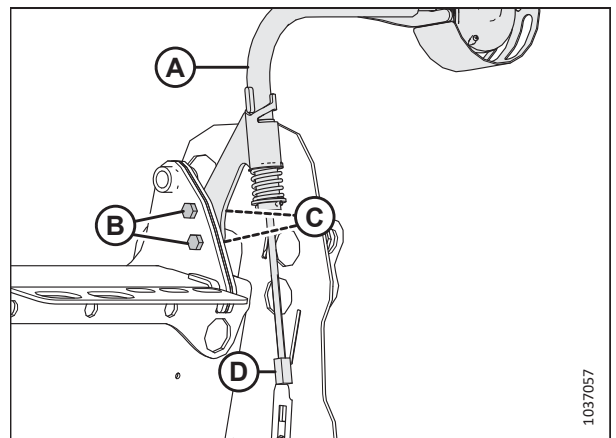

Figure 5.137: Right Clearance Light

5.22 Crop Dividers

Crop dividers separate the crop when harvesting. Remove them to install vertical knives, the sunflower attachment, and to decrease transport width.

5.22.1 Installing Crop Dividers

The crop dividers were removed from the header for shipping purposes. They will need to be installed.

NOTE:

This procedure applies to the standard crop dividers shipped with every header. If you are installing the optional Floating Crop Dividers kit (B7346), refer to the installation instructions provided with the kit.

1. Open the left endshield. For instructions, refer to [10.4.1 Opening Header Endshields, page 522](#).
2. Remove hairpin (A) securing multi-tool (B) to the bracket on the left endsheet.
3. Remove multi-tool (B). Insert the hairpin in the bracket.
4. Retrieve the previously removed crop dividers.

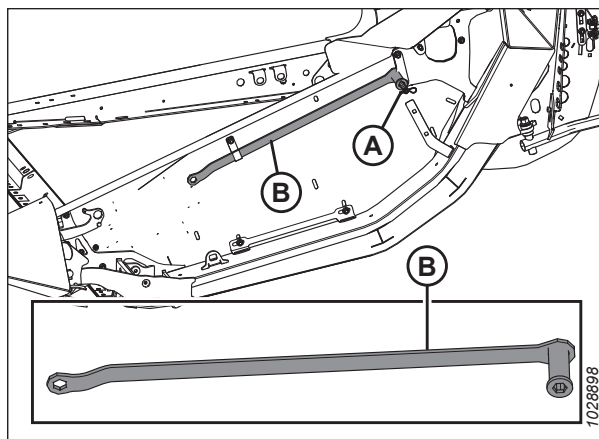

Figure 5.138: Left Endsheet

5. Insert lugs (A) on the crop divider into the holes in the knife drive box support as shown.
6. Remove lynch pin (B) from latch (C).

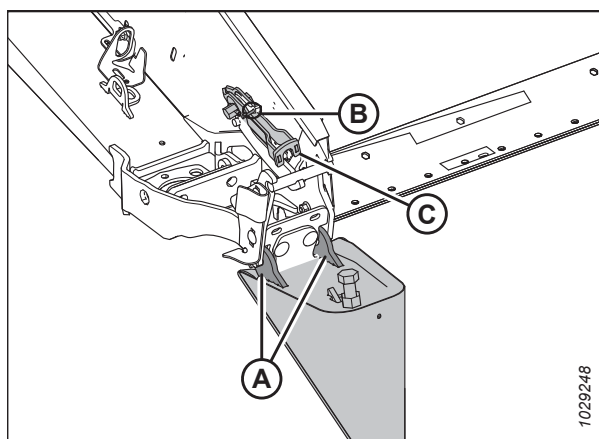

Figure 5.139: Crop Divider

COMPLETING HEADER ASSEMBLY

7. Lift the forward end of latch (A) and crop divider (B).

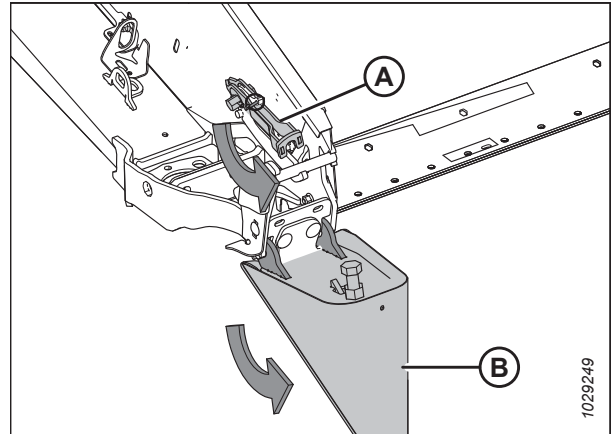

Figure 5.140: Crop Divider

8. Insert latch (A) into crop divider bolt (B).
9. Attach the multi-tool to latch-locking hex shaft (D). Rotate the multi-tool counter-clockwise to lock latch (A).
10. Secure latch (A) with lynch pin (C).
11. To close the latch, torque hex shaft (D) to 40–54 Nm (30–40 lbf·ft).
12. Tighten bolt (B) to increase the torque required to close the latch, or back the bolt off to decrease the torque required to close the latch.

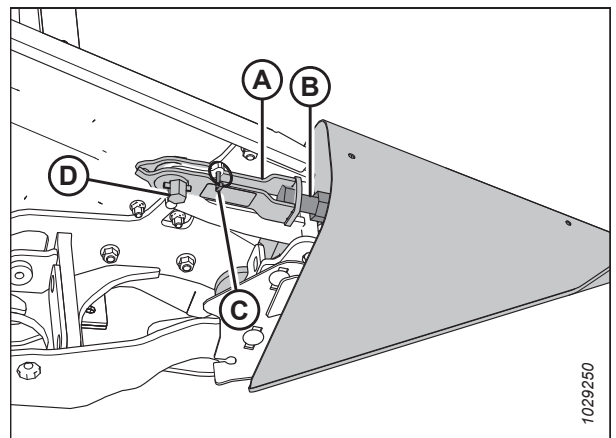

Figure 5.141: Crop Divider

13. Ensure that there is contact between plate (A) and guide (B).
14. Return the multi-tool to its storage location on the left end panel.
15. Close the left endshield. For instructions, refer to [10.4.2 Closing Header Endshields, page 523](#).

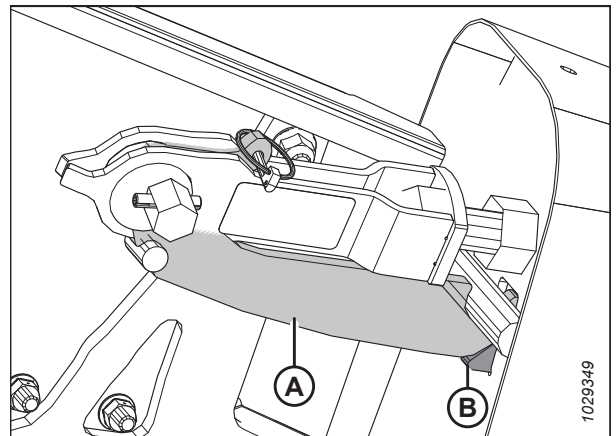

Figure 5.142: Crop Divider's Latch

COMPLETING HEADER ASSEMBLY

IMPORTANT:

Ensure that there is no contact between front support (A) and the back of crop divider (B). If there is too much contact, the front support may bend. There should be a gap of 10 mm (3/8 in.) (C) from the end panel and the front support to allow the crop divider to expand.

NOTE:

Part of the crop divider is illustrated as though it were transparent for the sake of clarity.

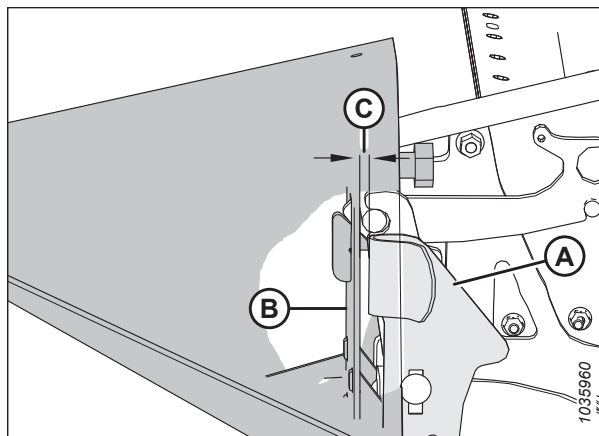

Figure 5.143: Front Support

5.22.2 Installing Crop Divider Rods

The crop divider rods can be installed on the ends of the crop dividers to help separate bushy crop.

1. Open the right and the left endshields. For instructions, refer to [10.4.1 Opening Header Endshields, page 522](#).
2. Undo lynch pin (A) securing divider rods (B) to the header endsheet.
3. Remove the divider rods from their shipping location.
4. Reinstall lynch pin (A).

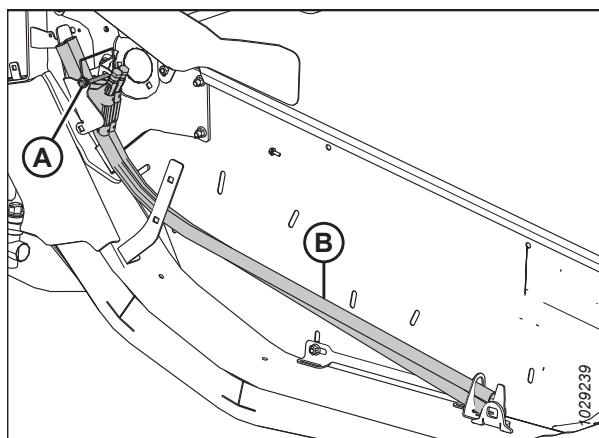

Figure 5.144: Divider Rods

5. Position crop divider rod (A) on the tip of the crop divider. Tighten bolt (B).
6. Repeat Step 2, [page 200](#) to Step 5, [page 200](#) on the opposite end of the header.
7. Close the right and left endshields. For instructions, refer to [10.4.2 Closing Header Endshields, page 523](#).

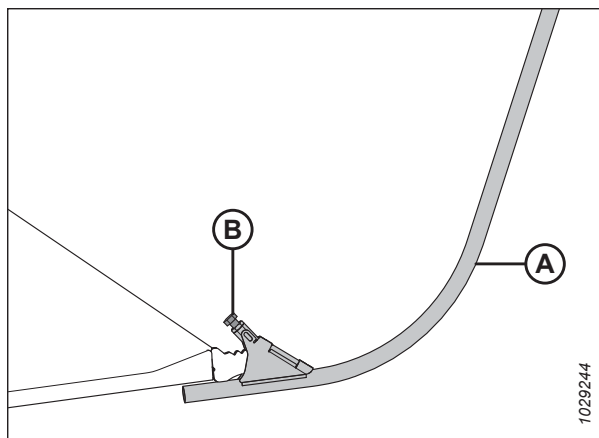

Figure 5.145: Divider Rod on Crop Divider

5.23 Installing Options

Once primary assembly of the header is complete, the optional kits included with the shipment will need to be installed.

1. Retrieve the kits supplied as options with the header, and install them according to the instructions supplied with each kit.
2. Proceed to Chapter [6 Performing Predelivery Checks, page 203](#).

Chapter 6: Performing Predelivery Checks

Once the header has been assembled and the optional kits have been installed, the header will need to be run up and its performance tested.



DANGER

To prevent bodily injury or death from the unexpected start-up of the machine, always stop the engine and remove the key from the ignition before making adjustments to the machine.

IMPORTANT:

Ensure that shipping material has not fallen into the header.

Perform the final checks listed on the Predelivery Checklist ([Predelivery Checklist, page 541](#)) to ensure that the header is field-ready. Refer to the procedures in this chapter for detailed instructions on performing the tasks listed in the Predelivery Checklist.

The completed Predelivery Checklist should be retained by the Operator or the Dealer.

6.1 Checking Tire Pressure – Option for D230 and D235

Some headers may have stabilizer wheels installed. If so, the tire pressure levels will need to be checked and, if necessary, adjusted.

Check the pressure of the transport/stabilizer tires. If necessary, inflate or deflate the tires to the pressure specified below:

Table 6.1 Tire Inflation Pressure

Size	Load Range	Pressure
225/75 R15	F	655 kPa (95 psi)

6.2 Checking Transport Wheel Bolt Torque – Option for D230 and D235

For headers with a transport wheel package, the wheel bolts securing the transport wheels must be torqued correctly before the header can be safely transported.

1. Measure the torque value of each wheel bolt. A correctly torqued wheel bolt will show a torque reading of 115 Nm (85 lbf·ft).
2. If a wheel bolt is not set to the correct torque value, adjust its torque as needed.
3. Tighten all wheel bolts according to the bolt-tightening pattern depicted in the illustration at right.

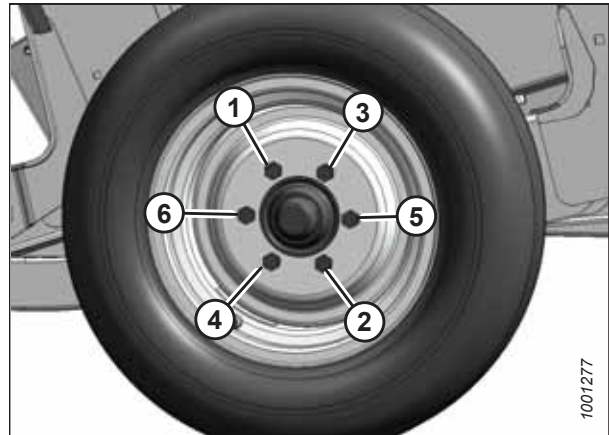

Figure 6.1: Sequence for Tightening Bolts

6.3 Checking Oil Level in Knife Drive Box

There must be a sufficient level of oil in each knife drive box for the knife drive to work correctly. You can inspect the oil level using the dipstick installed in each knife drive.

DANGER

To prevent bodily injury or death from the unexpected start-up of the machine, always stop the engine and remove the key from the ignition before making adjustments to the machine.

DANGER

Ensure that all bystanders have cleared the area.

1. Ensure that the header is level.
2. Lower the header fully.
3. Adjust the header angle so that the top of the knife drive box is level with the ground.
4. Shut down the engine, and remove the key from the ignition.
5. Open the endshield. For instructions, refer to [10.4.1 Opening Header Endshields, page 522](#).
6. Remove oil level dipstick (A), wipe it, and then reinstall it. Tighten it until it is finger-tight.
7. Remove the dipstick again to check the oil level. The oil level must be within range (B), between the lines near the bottom of the dipstick.
8. Add oil to the knife drive box if needed. For instructions on adding oil, refer to the header operator's manual.
9. Reinstall dipstick (A). Tighten the dipstick to 23 Nm (17 lbf·ft [204 lbf·in]).
10. If the header has two knife drives, repeat [Step 5, page 205](#) to [Step 9, page 205](#) to check the oil level for the other knife drive.

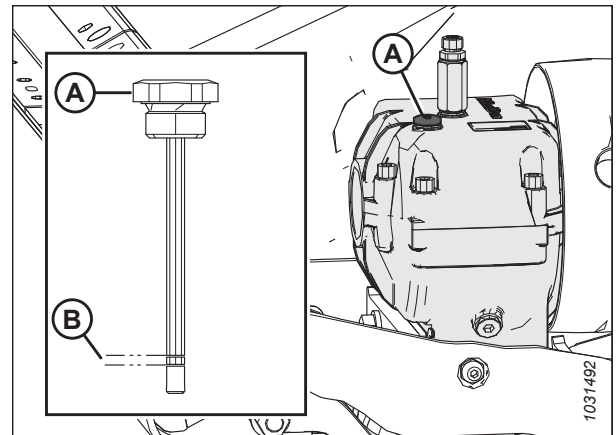

Figure 6.2: Knife Drive Box

6.4 Checking Oil Level in Header Drive Main Gearbox

The oil level in the header's main drive gearbox on the float module will need to be inspected before the header can be operated.

DANGER

To prevent injury or death from the unexpected start-up of the machine, always stop the engine and remove the key from the ignition before leaving the operator's seat for any reason.

DANGER

Ensure that all bystanders have cleared the area.

1. Lower the header fully.
2. Shut down the engine, and remove the key from the ignition.
3. Remove oil level plug (A) from main gearbox (B) and ensure that the oil level is up to the bottom of the hole.
4. Add oil if it is required. For instructions, refer to the header operator's manual.
5. Reinstall oil level plug (A).

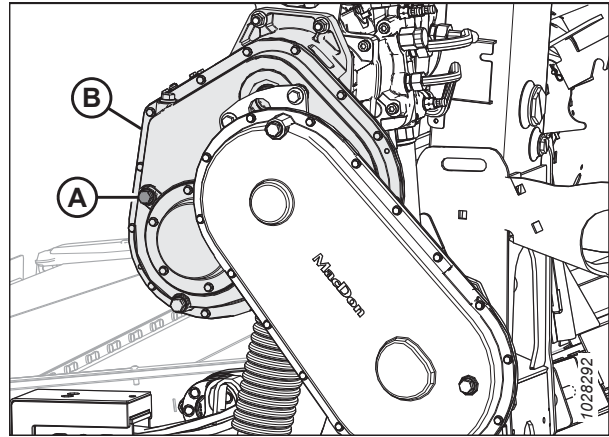

Figure 6.3: Header Drive Main Gearbox

6.5 Checking Oil Level in Header Drive Completion Gearbox

The oil level in the header drive completion gearbox will need to be inspected before the header can be operated.

DANGER

To prevent injury or death from the unexpected start-up of the machine, always stop the engine and remove the key from the ignition before leaving the operator's seat for any reason.

DANGER

Ensure that all bystanders have cleared the area.

1. Lower the header fully.
2. Shut down the engine, and remove the key from the ignition.
3. Ensure that the completion gearbox has been moved to the working position. For instructions, refer to [3.1 Repositioning Completion Gearbox to Working Position, page 35](#).
4. Remove oil level plug (A) from the completion gearbox. The oil should be at the level of the port.
5. If there is an insufficient amount of oil in the completion gearbox, remove filler plug (B) and add oil. For instructions, refer to the header operator's manual.
6. Reinstall oil level plug (A).

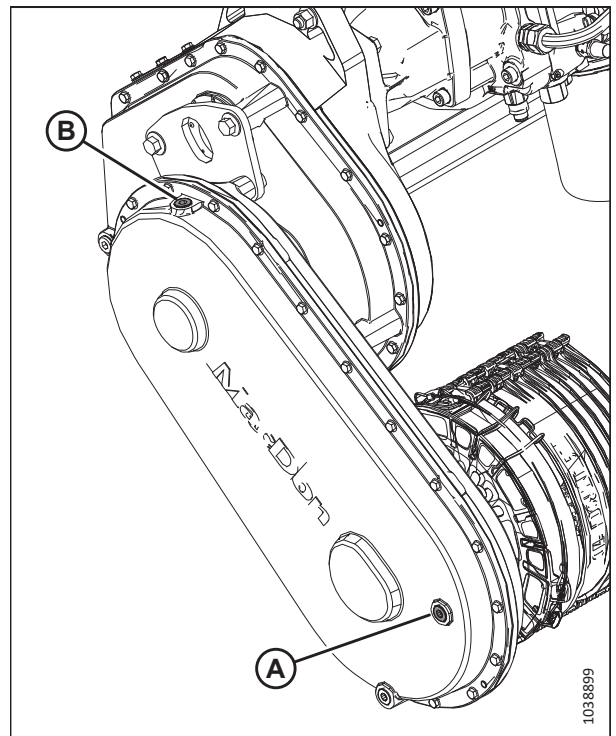

Figure 6.4: Header Drive Completion Gearbox

6.6 Checking Oil Level in Hydraulic Reservoir

The hydraulic oil used to operate the header is stored in the float module's reservoir. The oil level will need to be inspected.

DANGER

To prevent injury or death from the unexpected start-up of the machine, always stop the engine and remove the key from the ignition before leaving the operator's seat for any reason.

DANGER

Ensure that all bystanders have cleared the area.

NOTE:

Inspect the hydraulic oil level when the hydraulic oil is cold.

1. Lower the header to the ground.
2. Fully retract the center-link.
3. Shut down the engine, and remove the key from the ignition.
4. Ensure that the oil is at the appropriate level for the terrain as follows:
 - **Level terrain:** The oil level should fill approximately one half (A) of the gauge.
 - **Sloped terrain:** The oil level should fill approximately three quarters (B) of the gauge.

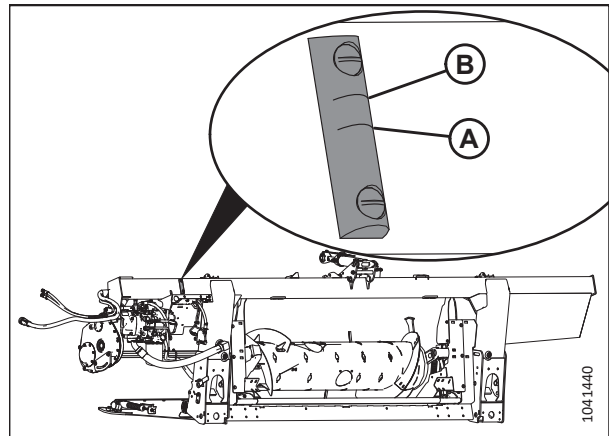

Figure 6.5: Oil Level Sight Gauge

6.7 Guard Identification

There are two different knife guard options available: pointed knife guards and the shorter PlugFree™ (or short) knife guards. Each type of guard has its own checking and adjusting procedures.

The following knife guards and hold-downs are used in pointed guard configurations:

NOTE:

Pointed knife guard configurations require two short knife guards, one at each end of the cutterbar.

NOTE:

A Four-Point Guard kit can be used to replace the knife guards. Four point guards are ideal for use in rocky conditions or for harvesting shatter-prone crops such as lentils. For more information, refer to the header parts catalog.

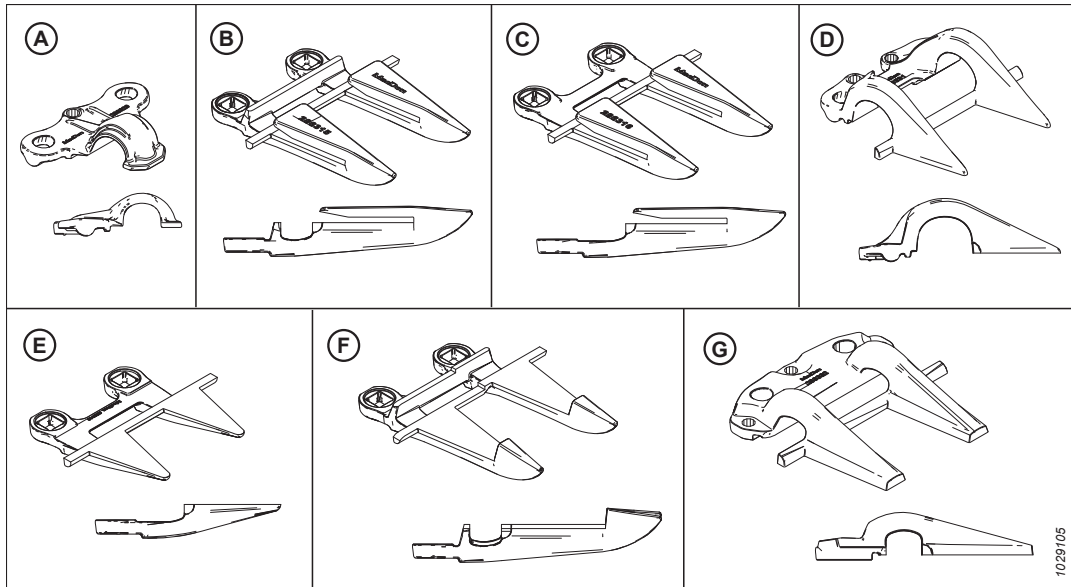

Figure 6.6: Guard and Hold-Down Types Used in Pointed Knife Guard Configurations

A - Pointed Hold-Down (MD #286329)

C - Pointed-End Knife Guard (without Wear Bar) (MD #286316)¹⁴

E - PlugFree™ End Knife Guard (without Wear Bar) (MD #286319)¹⁵

G - Pointed Center Hold-Down (MD #286332)

B - Pointed Knife Guard (MD #286315)

D - PlugFree™ End Hold-Down (MD #286331)

F - Pointed Center Knife Guard (MD #286317)¹⁶

Follow these procedures for checking and adjusting pointed knife guards:

- [6.7.1 Checking Hold-Down – Pointed Knife Guards, page 211](#)
- [6.7.2 Adjusting Hold-Down – Pointed Knife Guards, page 212](#)
- [6.7.3 Checking Center Hold-Down on Double-Knife Header – Pointed Knife Guards, page 213](#)
- [6.7.4 Adjusting Center Hold-Down on Double-Knife Header – Pointed Knife Guards, page 214](#)

14. Installed in positions 2, 3, and 4 on the drive side(s).

15. Installed in position 1 on the drive side(s). Single-knife headers use a standard guard on the right end.

16. Double-knife headers only.

PERFORMING PREDELIVERY CHECKS

The following knife guards and hold-downs are used in short knife guard configurations:

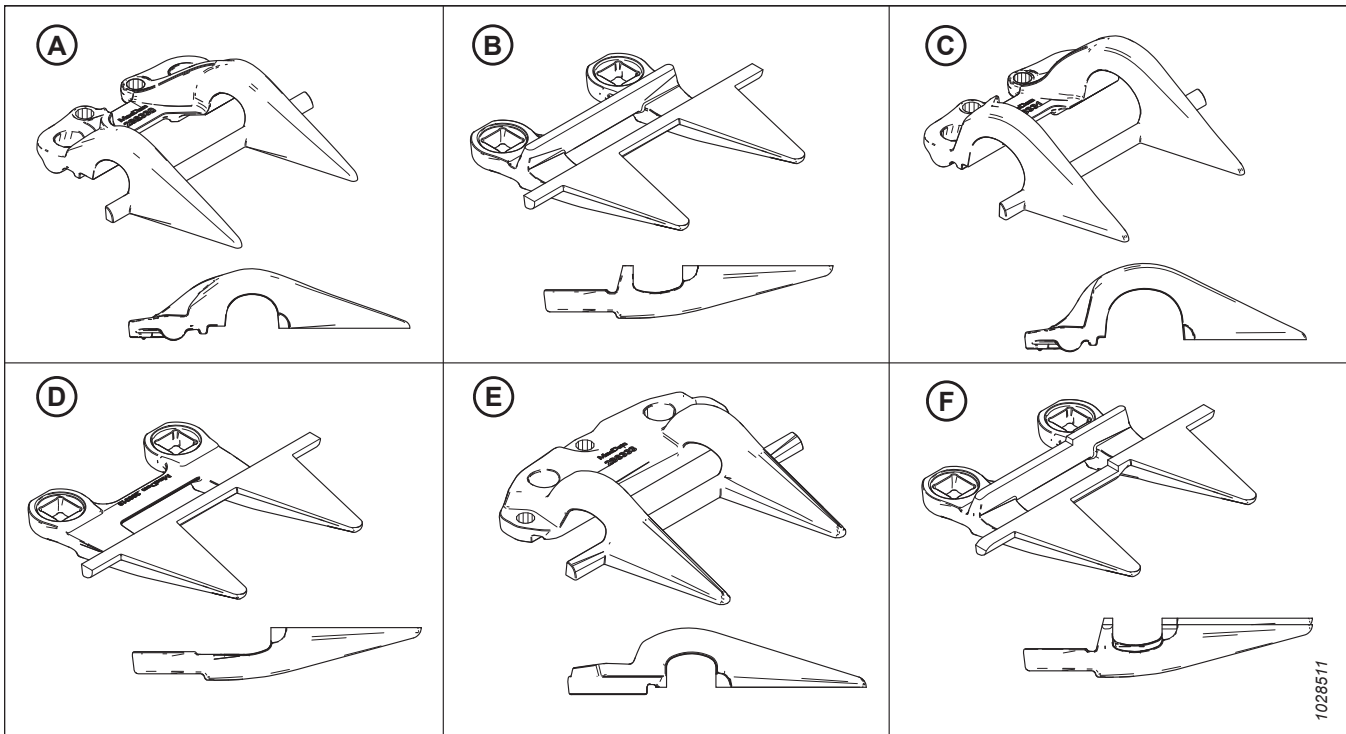

Figure 6.7: Guard and Hold-Down Types used in Short Knife Guard Configurations

A - PlugFree™ Hold-Down (MD #286330)
C - PlugFree™ End Hold-Down (MD #286331)¹⁷
E - PlugFree™ Center Hold-Down (MD #286333)

B - PlugFree™ Knife Guard (MD #286318)
D - PlugFree™ End Knife Guard (without Wear Bar) (MD #286319)¹⁸
F - PlugFree™ Center Knife Guard (MD #286320)¹⁹

Follow these procedures for checking and adjusting short knife guards:

- [6.7.5 Checking Hold-Down – Short Knife Guards, page 215](#)
- [6.7.6 Adjusting Hold-Down – Short Knife Guards, page 215](#)
- [6.7.7 Checking Center Hold-Down on Double-Knife Headers – Short Knife Guards, page 216](#)
- [6.7.8 Adjusting Center Hold-Down – Short Knife Guards, page 217](#)

17. Installed in positions 1–3 on the drive side(s); installed in position 1 at the right end of single-knife headers.

18. Installed in positions 1–4 on the drive side(s). Single-knife headers use a standard guard on the right end of the header.

19. Double-knife headers only.

6.7.1 Checking Hold-Down – Pointed Knife Guards

The pointed knife guard hold-downs prevent the knife sections on the cutterbar from lifting off of the guards, while still allowing the knife to slide. Inspect the hold-downs to ensure that there is an adequate clearance between the hold-downs and knife sections.

This procedure is for standard hold-downs. To check the center hold-down on double-knife headers, refer to [6.7.3 Checking Center Hold-Down on Double-Knife Header – Pointed Knife Guards, page 213](#).

DANGER

To prevent bodily injury or death from the unexpected start-up of the machine, always stop the engine and remove the key from the ignition before making adjustments to the machine.

DANGER

Ensure that all bystanders have cleared the area.

WARNING

To prevent bodily injury from the fall of a raised reel, always engage the reel safety props before going under the raised reel for any reason.

WARNING

Wear heavy gloves when working around or handling knives.

1. Raise the reel fully.
2. Shut down the engine, and remove the key from the ignition.
3. Engage the reel safety props. For instructions, refer to [10.3.1 Engaging Reel Safety Props, page 519](#).
4. Open the endshield. For instructions, refer to [10.4.1 Opening Header Endshields, page 522](#).
5. Rotate the flywheel attached to the knife drive box to position knife section (A) under hold-down (B), and between guard (C).
6. Push down on knife section (A) with approximately 44 N (10 lbf) of force, and use a feeler gauge to measure the clearance between hold-down (B) and the knife section. Ensure the clearance is 0.1–0.5 mm (0.004–0.020 in.).
7. If adjustment is necessary, refer to [6.7.2 Adjusting Hold-Down – Pointed Knife Guards, page 212](#).
8. Close the endshield. For instructions, refer to [10.4.2 Closing Header Endshields, page 523](#).

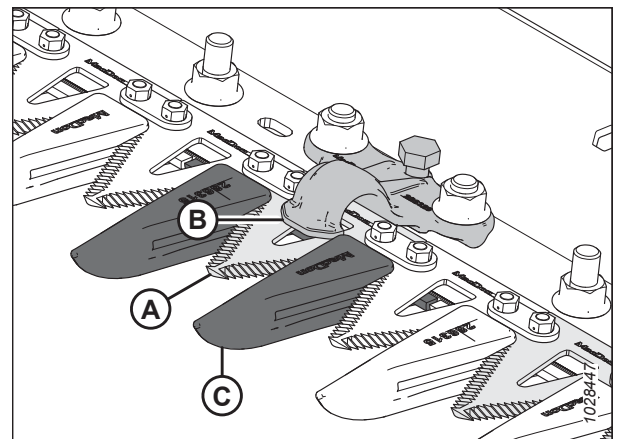

Figure 6.8: Pointed Guard Hold-Down

6.7.2 Adjusting Hold-Down – Pointed Knife Guards

If a pointed or four-point knife guard hold-down is binding the knife, adjust the hold-down.

This procedure applies to standard hold-downs. To adjust the center hold-down on double-knife headers, refer to [6.7.4 Adjusting Center Hold-Down on Double-Knife Header – Pointed Knife Guards, page 214](#).

DANGER

To prevent bodily injury or death from the unexpected start-up of the machine, always stop the engine and remove the key from the ignition before making adjustments to the machine.

DANGER

Ensure that all bystanders have cleared the area.

WARNING

To prevent bodily injury from the fall of a raised reel, always engage the reel safety props before going under the raised reel for any reason.

WARNING

Wear heavy gloves when working around or handling knives.

1. Raise the reel fully.
2. Shut down the engine, and remove the key from the ignition.
3. Engage the reel safety props. For instructions, refer to [10.3.1 Engaging Reel Safety Props, page 519](#).
4. Adjust the hold-down clearance as follows:
 - To lower the front of hold-down (A) and decrease the clearance, rotate adjuster bolt (B) clockwise.
 - To raise the front of hold-down (A) and increase the clearance, rotate adjuster bolt (B) counterclockwise.

NOTE:

For larger adjustments, it may be necessary to loosen nuts (C) before rotating adjuster bolt (B). After adjustment, retighten the nuts to 85 Nm (63 lbf-ft).

5. Check the hold-down clearance. For instructions, refer to [6.7.1 Checking Hold-Down – Pointed Knife Guards, page 211](#).

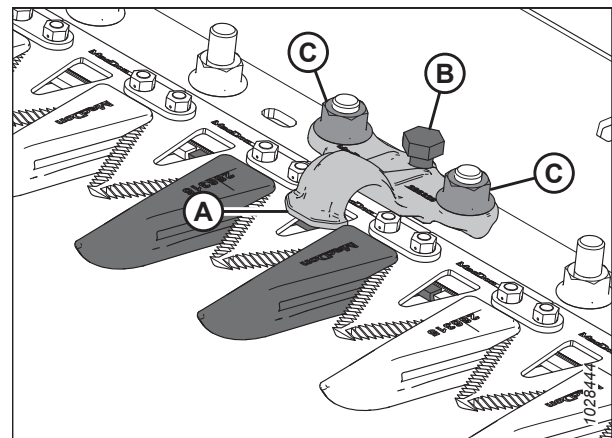

Figure 6.9: Pointed Hold-Down

6. Run the engine at a low idle and listen for noise caused by insufficient clearance. Repeat Step 4, [page 212](#) to Step 5, [page 212](#) if necessary.

IMPORTANT:

An insufficient hold-down clearance will cause the knife and the guards to overheat.

6.7.3 Checking Center Hold-Down on Double-Knife Header – Pointed Knife Guards

The pointed center knife guard hold-down prevents the center knife section on the cutterbar from lifting off of the guard while still allowing the knives to slide. Inspect the center hold-down to ensure that there is adequate clearance between the hold-down and the center knife section.

DANGER

To prevent bodily injury or death from the unexpected start-up of the machine, always stop the engine and remove the key from the ignition before making adjustments to the machine.

DANGER

Ensure that all bystanders have cleared the area.

WARNING

To prevent bodily injury from the fall of a raised reel, always engage the reel safety props before going under the raised reel for any reason.

WARNING

Wear heavy gloves when working around or handling knives.

1. Raise the reel fully.
2. Shut down the engine, and remove the key from the ignition.
3. Engage the reel safety props. For instructions, refer to [10.3.1 Engaging Reel Safety Props, page 519](#).
4. Open the endshield. For instructions, refer to [10.4.1 Opening Header Endshields, page 522](#).
5. Rotate the flywheel attached to the knife drive box to position the knife fully inboard until the knife sections are under hold-down (A). Repeat this step to move the other knife.
6. Push down on the knife section with approximately 44 N (10 lbf) of force, and use a feeler gauge to measure the clearance between hold-down (A) and the knife section. Ensure that the clearance is as follows:
 - At tip (B) of hold-down: 0.1–0.5 mm (0.004–0.020 in.)
 - At rear (C) of hold-down: 0.1–1.0 mm (0.004–0.040 in.)
7. If adjustment is required, refer to [6.7.4 Adjusting Center Hold-Down on Double-Knife Header – Pointed Knife Guards, page 214](#).
8. After tightening nuts (D), recheck the clearance and adjust if necessary.
9. Close the endshield. For instructions, refer to [10.4.2 Closing Header Endshields, page 523](#).

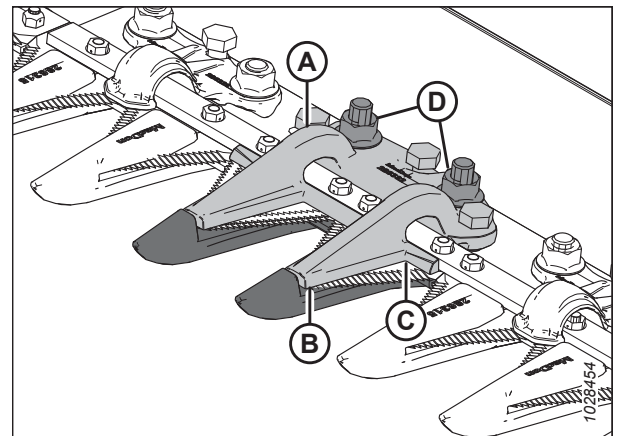

Figure 6.10: Pointed Center Hold-Down

6.7.4 Adjusting Center Hold-Down on Double-Knife Header – Pointed Knife Guards

If the pointed center knife guard hold-down is binding the knife, adjust it.

DANGER

To prevent bodily injury or death from the unexpected start-up of the machine, always stop the engine and remove the key from the ignition before making adjustments to the machine.

DANGER

Ensure that all bystanders have cleared the area.

WARNING

To prevent bodily injury from the fall of a raised reel, always engage the reel safety props before going under the raised reel for any reason.

WARNING

Wear heavy gloves when working around or handling knives.

1. Raise the reel fully.
2. Shut down the engine, and remove the key from the ignition.
3. Engage the reel safety props. For instructions, refer to [10.3.1 Engaging Reel Safety Props, page 519](#).
4. Loosen mounting hardware (B).
5. Adjust the hold-down clearance as follows:
 - To increase the clearance, rotate adjuster bolts (A) clockwise (tighten the bolts).
 - To decrease the clearance, rotate adjuster bolts (A) counterclockwise (loosen the bolts).
6. To adjust the clearance at the hold-down tip only, use adjustment bolt (C) as follows:
 - To increase the clearance, rotate adjuster bolt (C) counterclockwise (loosen the bolts).
 - To decrease the clearance, rotate adjuster bolt (C) clockwise (tighten the bolts).

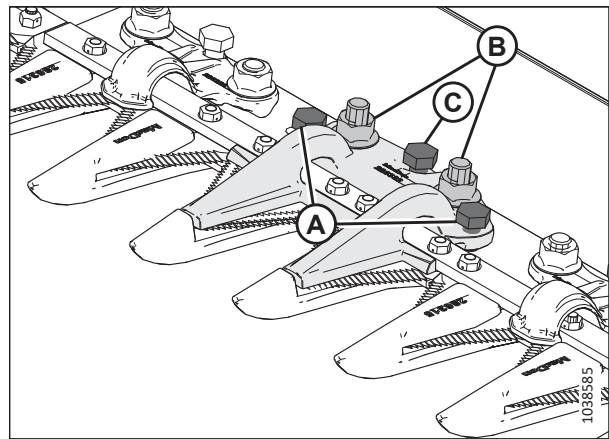

Figure 6.11: Pointed Center Hold-Down

7. Tighten nuts (B) to 85 Nm (63 lbf-ft).
8. Run the engine at a low idle, and listen for noise caused by insufficient clearance.

IMPORTANT:

An insufficient hold-down clearance will cause the knife and the guards to overheat.

9. Check the center guard clearance. For more information, refer to [6.7.3 Checking Center Hold-Down on Double-Knife Header – Pointed Knife Guards, page 213](#).

6.7.5 Checking Hold-Down – Short Knife Guards

The short knife guard hold-downs prevent the knife sections on the cutterbar from lifting off of the guards while still allowing the knife to slide. Inspect the hold-downs to ensure that there is adequate clearance between the hold-downs and knife sections.

To check the center hold-down on double-knife headers, refer to [6.7.7 Checking Center Hold-Down on Double-Knife Headers – Short Knife Guards, page 216](#).

DANGER

To prevent bodily injury or death from the unexpected start-up of the machine, always stop the engine and remove the key from the ignition before making adjustments to the machine.

DANGER

Ensure that all bystanders have cleared the area.

WARNING

To prevent bodily injury from the fall of a raised reel, always engage the reel safety props before going under the raised reel for any reason.

WARNING

Wear heavy gloves when working around or handling knives.

1. Raise the reel fully.
2. Shut down the engine, and remove the key from the ignition.
3. Engage the reel safety props. For instructions, refer to [10.3.1 Engaging Reel Safety Props, page 519](#).
4. Rotate the flywheel attached to the knife drive box to position the knife inboard until the knife sections are under hold-down (A).
5. Push down on the knife section with approximately 44 N (10 lbf) of force and use a feeler gauge to measure the clearance between the tip of hold-down (B) and the knife section. Ensure that the clearance is 0.1–0.5 mm (0.004–0.020 in.).
6. If adjustment is required, refer to [6.7.6 Adjusting Hold-Down – Short Knife Guards, page 215](#).

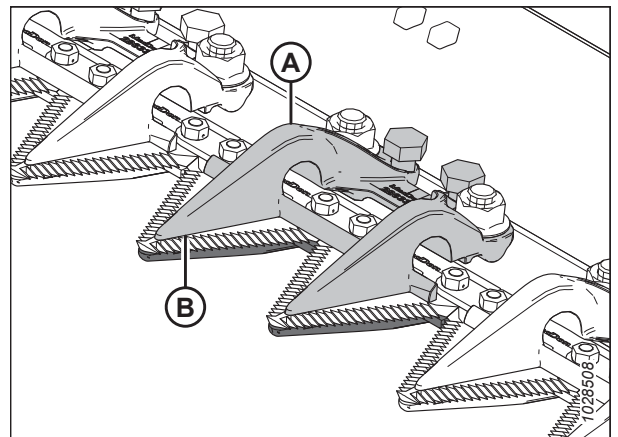

Figure 6.12: Short Knife Guards

6.7.6 Adjusting Hold-Down – Short Knife Guards

If a short knife guard hold-down is binding its knife, adjust the hold-down.

To adjust the center hold-down on double-knife headers, refer to [6.7.8 Adjusting Center Hold-Down – Short Knife Guards, page 217](#).

⚠ DANGER

To prevent bodily injury or death from the unexpected start-up of the machine, always stop the engine and remove the key from the ignition before making adjustments to the machine.

⚠ DANGER

Ensure that all bystanders have cleared the area.

⚠ WARNING

To prevent bodily injury from the fall of a raised reel, always engage the reel safety props before going under the raised reel for any reason.

⚠ WARNING

Wear heavy gloves when working around or handling knives.

1. Raise the reel fully.
2. Shut down the engine, and remove the key from the ignition.
3. Engage the reel safety props. For instructions, refer to [10.3.1 Engaging Reel Safety Props, page 519](#).
4. Adjust the hold-down clearance as follows:
 - To decrease the clearance, rotate adjuster bolts (A) clockwise.
 - To increase the clearance, rotate adjuster bolts (A) counterclockwise.

NOTE:

For larger adjustments, loosen nuts (B) before rotating adjuster bolts (A). After adjustment, retighten the nuts to 85 Nm (63 lbf-ft).

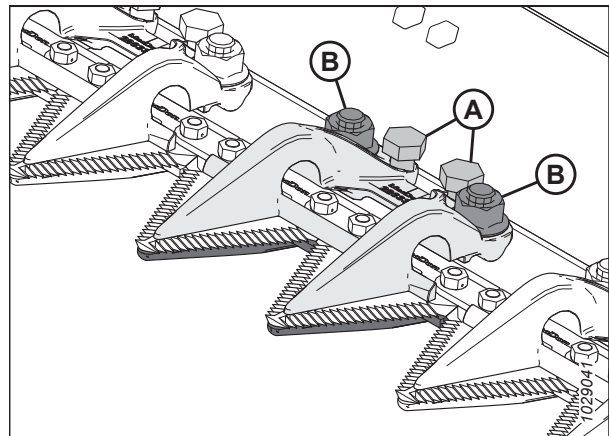

Figure 6.13: Short Knife Guard Hold-Down

5. Run the header at a low idle, and listen for noise caused by insufficient clearance. Adjust the header as necessary.

IMPORTANT:

An insufficient hold-down clearance will cause the knife and the guards to overheat.

6. Disengage the reel safety props. For instructions, refer to [10.3.2 Disengaging Reel Safety Props, page 520](#).

6.7.7 Checking Center Hold-Down on Double-Knife Headers – Short Knife Guards

The short center knife guard hold-down prevents the center knife sections on the cutterbar from lifting off of the guard while still allowing the knife to slide. Inspect the center hold-down to ensure that there is adequate clearance between the hold-down and the center knife sections.

⚠ DANGER

To prevent bodily injury or death from the unexpected start-up of the machine, always stop the engine and remove the key from the ignition before making adjustments to the machine.

⚠ DANGER

Ensure that all bystanders have cleared the area.

⚠ WARNING

To prevent bodily injury from the fall of a raised reel, always engage the reel safety props before going under the raised reel for any reason.

⚠ WARNING

Wear heavy gloves when working around or handling knives.

1. Raise the reel fully.
2. Shut down the engine, and remove the key from the ignition.
3. Engage the reel safety props. For instructions, refer to [10.3.1 Engaging Reel Safety Props, page 519](#).
4. Open the endshield. For instructions, refer to [10.4.1 Opening Header Endshields, page 522](#).
5. Rotate the flywheel attached to the knife drive box to position the knife inboard until the knife section is under hold-down (A). Repeat this step to move the other knife.
6. Push down on the knife section with approximately 44 N (10 lbf) of force. Use a feeler gauge to measure the clearance between hold-down (A) and the knife section. Ensure that the clearance is as follows:
 - At tip (B) of hold-down: 0.1–0.5 mm (0.004–0.020 in.)
 - At rear (C) of hold-down: 0.1–1.0 mm (0.004–0.040 in.)
7. If adjustment is required, refer to [6.7.8 Adjusting Center Hold-Down – Short Knife Guards, page 217](#).
8. Tighten nuts (D), recheck the clearance, and adjust if necessary.
9. Close the endshield. For instructions, refer to [10.4.2 Closing Header Endshields, page 523](#).

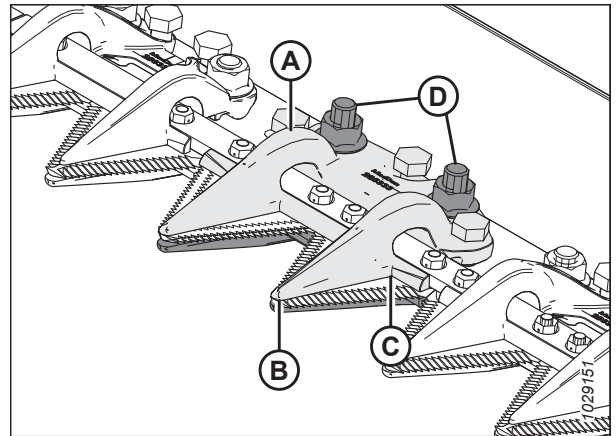

Figure 6.14: Center Knife Guard Hold-Down

6.7.8 Adjusting Center Hold-Down – Short Knife Guards

If a short knife guard hold-down is binding the knife, adjust the hold-down.

⚠ DANGER

To prevent bodily injury or death from the unexpected start-up of the machine, always stop the engine and remove the key from the ignition before making adjustments to the machine.

⚠ DANGER

Ensure that all bystanders have cleared the area.

WARNING

To prevent bodily injury from the fall of a raised reel, always engage the reel safety props before going under the raised reel for any reason.

WARNING

Wear heavy gloves when working around or handling knives.

1. Raise the reel fully.
2. Shut down the engine, and remove the key from the ignition.
3. Engage the reel safety props. For instructions, refer to [10.3.1 Engaging Reel Safety Props, page 519](#).
4. Loosen mounting hardware (B).
5. Adjust the hold-down clearance as follows:
 - To increase the clearance, rotate adjuster bolts (A) clockwise (tighten the bolts).
 - To decrease the clearance, rotate adjuster bolts (A) counterclockwise (loosen the bolts).
6. To adjust the clearance at the tip of the hold-down, turn adjustment bolt (C) as follows:
 - To increase the clearance, turn adjuster bolt (C) counterclockwise (loosen the bolts).
 - To decrease the clearance, turn adjuster bolt (C) clockwise (tighten the bolts).

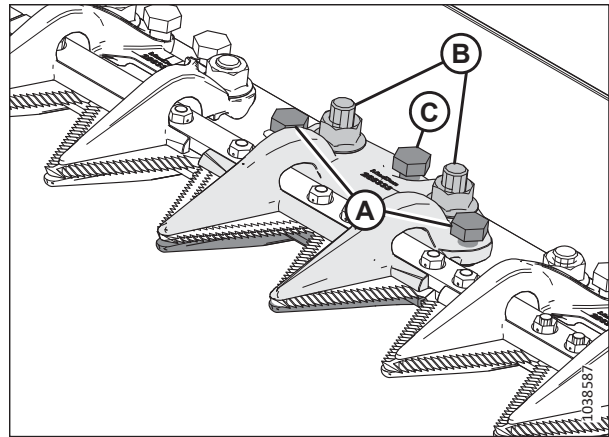

Figure 6.15: Center Hold-Down

7. Torque nuts (B) to 85 Nm (63 lbf·ft).
8. Run the engine at a low idle while listening for noise caused by insufficient clearance. Adjust the knives as necessary.

IMPORTANT:

An insufficient hold-down clearance will cause the knife and the guards to overheat.

6.7.9 Adjusting Knife Guards and Guard Bar

If a knife guard or the guard bar is misaligned due to contact with a rock or obstruction, use the guard straightening tool to correct the alignment.

DANGER

To prevent bodily injury or death from the unexpected start-up of the machine, always stop the engine and remove the key from the ignition before making adjustments to the machine.

WARNING

To prevent bodily injury from the fall of a raised reel, always engage the reel safety props before going under the raised reel for any reason.

WARNING

Wear heavy gloves when working around or handling knives.

PERFORMING PREDELIVERY CHECKS

1. Raise the reel fully.
2. Shut down the engine, and remove the key from the ignition.
3. Engage the reel safety props. For instructions, refer to [10.3.1 Engaging Reel Safety Props, page 519](#).
4. To adjust the guard tips upward, position the guard straightening tool as shown and pull the tool up.

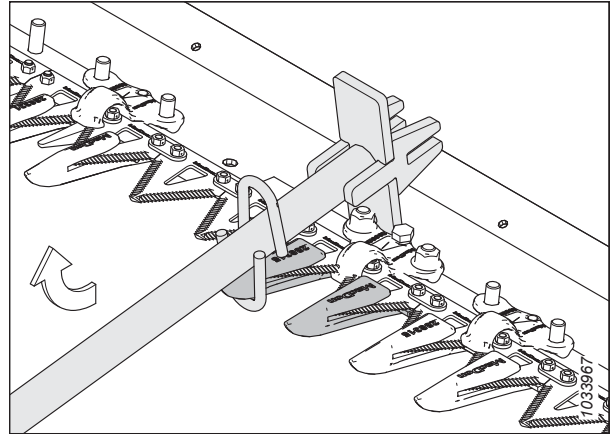

Figure 6.16: Upward Adjustment – Pointed Guard

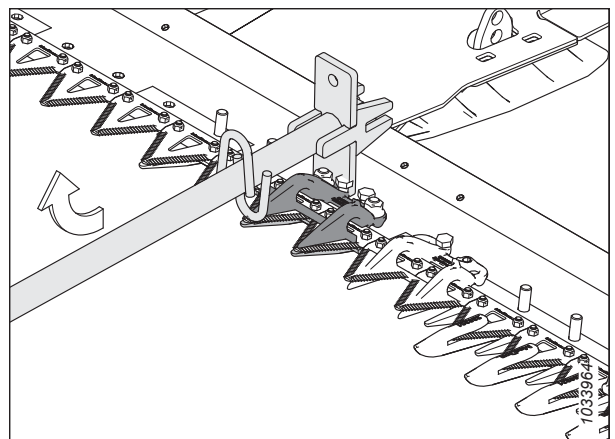

Figure 6.17: Upward Adjustment – Short Knife Guard

5. To adjust the guard tips downward, position the guard straightening tool as shown and push the tool down.

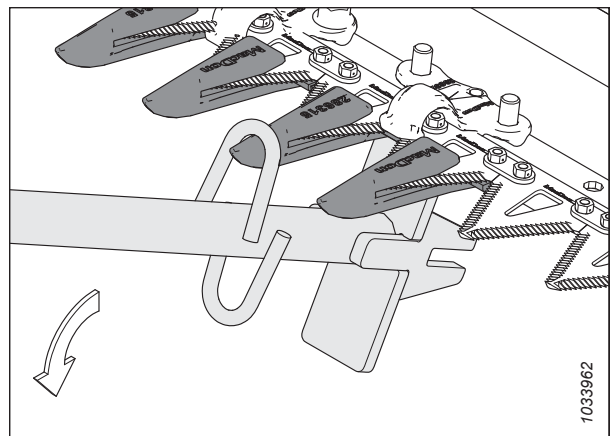

Figure 6.18: Downward Adjustment – Pointed Guard

PERFORMING PREDELIVERY CHECKS

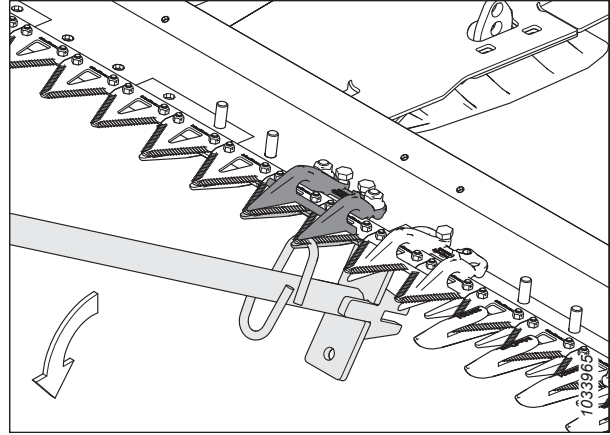

Figure 6.19: Downward Adjustment – Short Knife Guard

6. To adjust the guard bar, position the guard straightening tool as shown, then push down or pull up on the tool accordingly.

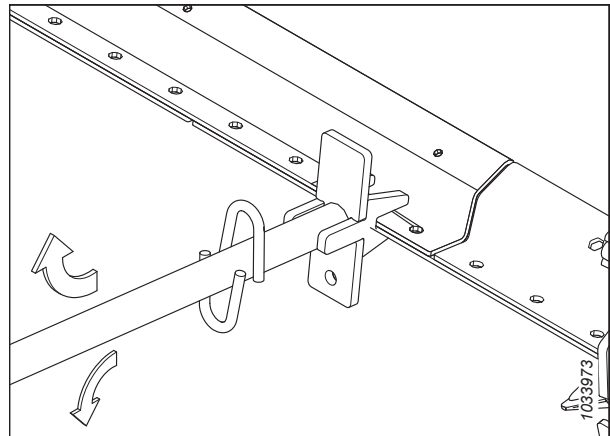

Figure 6.20: Guard Bar Adjustment – No Guards

6.8 Checking and Adjusting Reel-to-Endsheet Clearance

Reel-to-endsheet clearance refers to the side distance between the outboard edge of the reel and the endsheets on the header. If the reel clearance is not satisfactory, it will need to be adjusted.

DANGER

To prevent bodily injury or death from the unexpected start-up of the machine, always stop the engine and remove the key from the ignition before making adjustments to the machine.

DANGER

Ensure that all bystanders have cleared the area.

Checking reel clearance

1. Raise or lower the header until the cutterbar sits 254–356 mm (10–14 in.) above the ground.
2. Lower the reel fully.
3. Extend or retract the reel until the 5 on reel fore-aft indicator (A) is hidden by sensor support (B).
4. Shut down the engine, and remove the key from the ignition.

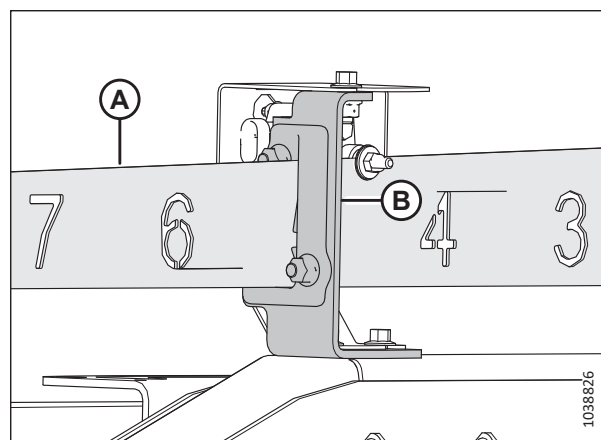

Figure 6.21: Reel Fore-Aft Indicator

PERFORMING PREDELIVERY CHECKS

5. Manually rotate the reel to position a tine tube above the cutterbar.
6. Measure clearance (A) at locations (B) between the reel tine tube and the endsheet at both ends of the header. If the reel is centered, the clearances will be identical. If the clearance needs to be adjusted, proceed to the next step.

NOTE:

If reel endshields are pre-installed, measure between the reel endshield and the header endsheet, at the location of the tine tube, as shown.

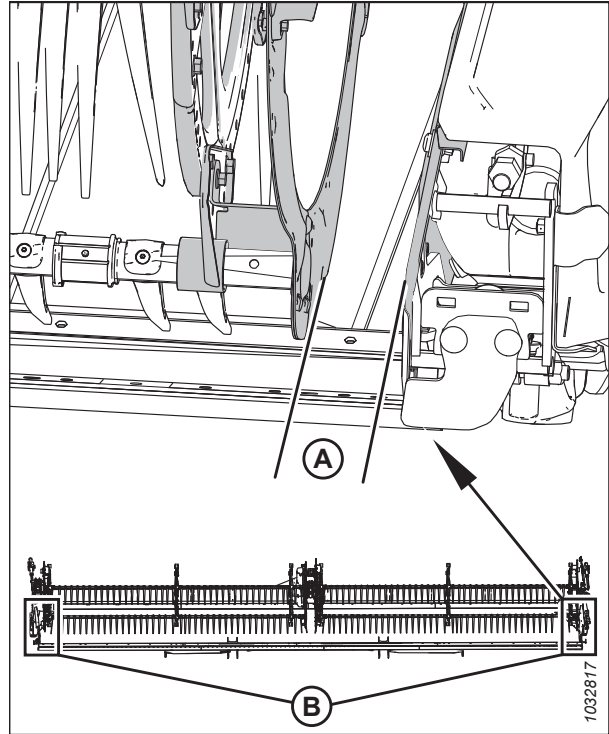

Figure 6.22: Reel Clearance – Double-Reel Header

Adjusting reel clearance – single-reel headers

7. Center the reel as follows:
 - a. Loosen bolt (A) on brace (B) on the right reel arm.
 - b. Move the forward end of reel support arm (C) laterally as needed to center the reel.
 - c. Torque bolts (A) to 457 Nm (337 lbf-ft).

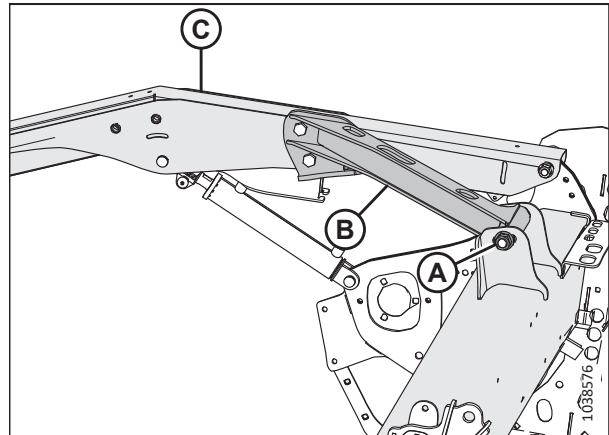

Figure 6.23: Right Support Arm – Single-Reel Header

PERFORMING PREDELIVERY CHECKS

Adjusting reel clearance – double-reel headers

8. Center the reel as follows:
 - a. Loosen bolt (A) on brace (B) at the center support arm.
 - b. Move the forward end of reel support arm (C) laterally as needed to center the reel.
 - c. Torque bolt (A) to 457 Nm (337 lbf·ft).

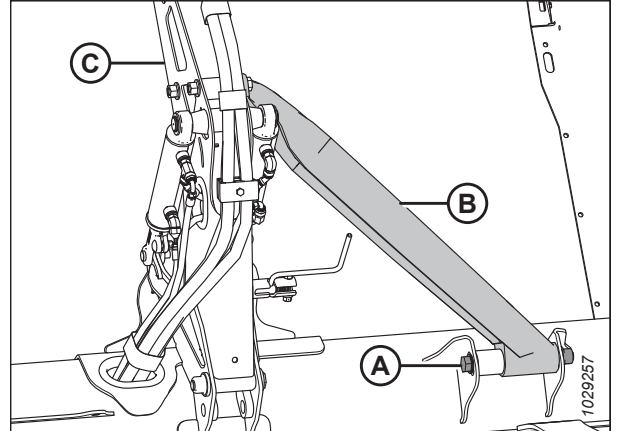

Figure 6.24: Center Support Arm – Double-Reel Header

6.9 Reel-to-Cutterbar Clearance

There must be a sufficient clearance between the reel fingers and the cutterbar to ensure that the reel fingers do not contact the cutterbar during operation. The clearance is set at the factory, but some adjustment may be necessary before operating the header.

Measure clearance (A) between the tip of the reel finger and the guard (pointed guard [B] or short guard [C], depending on the configuration of the header). Compare the measurement to the specifications listed in the table below:

Table 6.2 Finger to Guard/Cutterbar Clearance – Single-Reel Headers

Header	End Panels
D225	30 mm (1.18 in.)

Table 6.3 Finger to Guard/Cutterbar Clearance – Double-Reel Headers

Header	End Panels	Beside Center Arm
D230	25 mm (1 in.)	25 mm (1 in.)
D235		

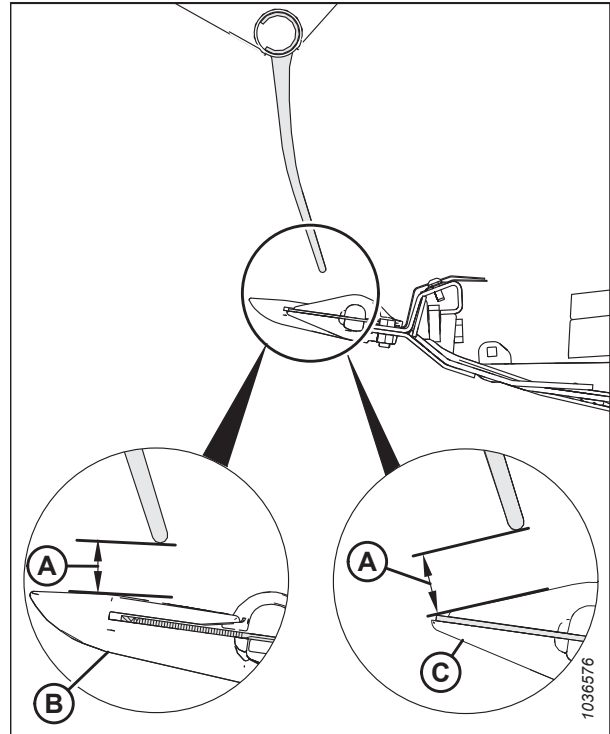

Figure 6.25: Finger Clearance

6.9.1 Measuring Reel-to-Cutterbar Clearance

Make sure there is sufficient clearance between the reel and the cutterbar to prevent the knife from cutting reel finger tips off during operation.

DANGER

To prevent injury or death from the unexpected start-up of the machine, always stop the engine and remove the key from the ignition before leaving the operator's seat for any reason.

DANGER

Ensure that all bystanders have cleared the area.

PERFORMING PREDELIVERY CHECKS

1. Park the combine on a level surface.
2. Adjust the reel fore-aft position until the 7 on fore-aft indicator (A) is hidden by sensor support (B).

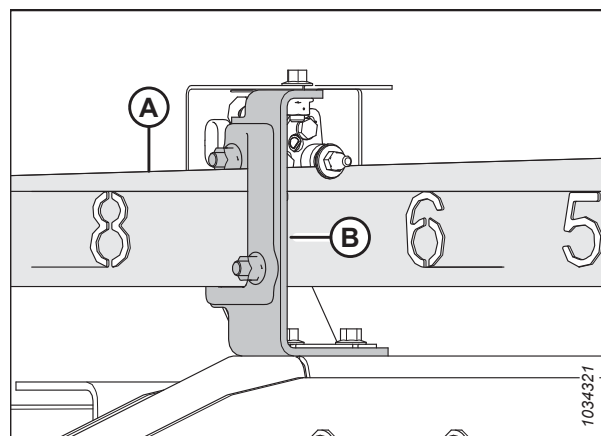

Figure 6.26: Fore-Aft Position

3. Shut down the engine, and remove the key from the ignition.
4. Rotate the reel by hand until a tine tube is directly above the cutterbar.
5. Measure and record clearance (A) from the finger tip to the top of pointed guard (B) or short guard (C). For clearance specifications, refer to [6.9 Reel-to-Cutterbar Clearance](#), page 224.

For measurement locations, refer to:

- Figure 6.28, page 226 – single-reel headers
- Figure 6.29, page 226 – double-reel headers

6. If required, adjust the reel clearance. For instructions, refer to [6.9.2 Adjusting Reel-to-Cutterbar Clearance](#), page 226.

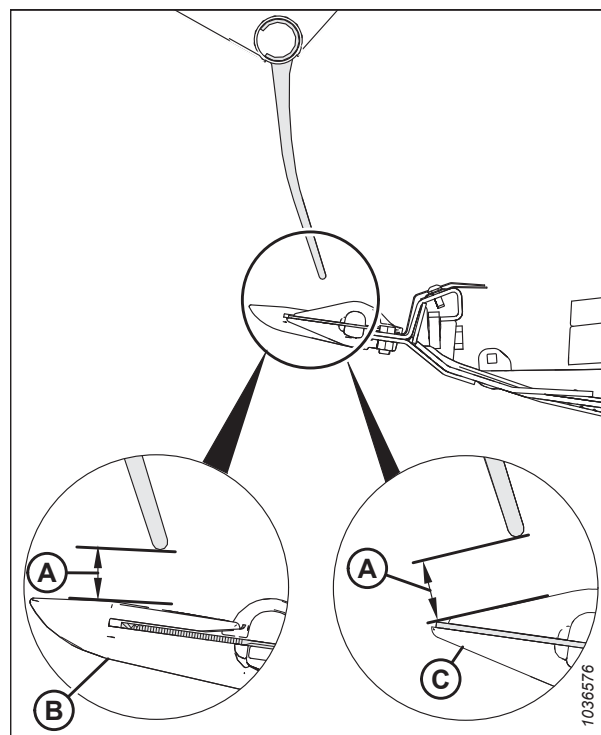

Figure 6.27: Measurement from Finger Tip to Guard

PERFORMING PREDELIVERY CHECKS

Single-reel header measurement locations (A): Outer ends of the reel (two places).

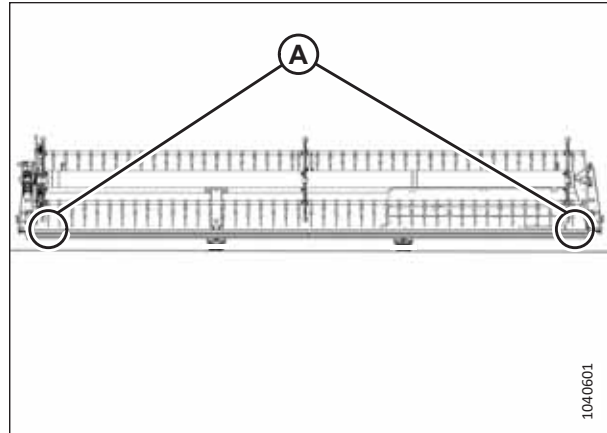

Figure 6.28: Single-Reel Header Measurement Locations

Double-reel header measurement locations (A): Both ends of both reels (four places).

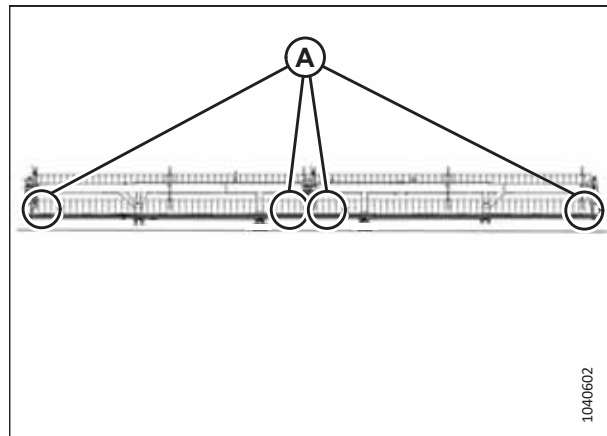

Figure 6.29: Double-Reel Header Measurement Locations

6.9.2 Adjusting Reel-to-Cutterbar Clearance

If the clearance between the reel fingers and the cutterbar is insufficient, it will need to be adjusted to prevent the equipment from being damaged.

NOTE:

This procedure can be performed with the reel fore-aft cylinders in either the standard position or the canola-harvesting position, as long as the fore-aft cylinders remain in the same position for the duration of the procedure.

DANGER

To prevent injury or death from the unexpected start-up of the machine, always stop the engine and remove the key from the ignition before leaving the operator's seat for any reason.

DANGER

Ensure that all bystanders have cleared the area.

1. Measure the reel-to-cutterbar clearance. For instructions, refer to [6.9.1 Measuring Reel-to-Cutterbar Clearance, page 224](#).

PERFORMING PREDELIVERY CHECKS

2. Position the header so that the cutterbar is 254–356 mm (10–14 in.) off the ground.
3. Lower the reel fully and continue holding the control button down to phase the cylinders.
4. Shut down the engine, and remove the key from the ignition.
5. Adjust the clearance at the outboard ends of the reel as follows:

- a. Loosen bolt (A) on the outer arm cylinder.
- b. Adjust cylinder rod (B) as needed:
 - To increase the clearance between the reel fingers and the cutterbar, turn cylinder rod (B) out of the clevis.
 - To decrease the clearance between the reel fingers and the cutterbar, turn cylinder rod (B) into the clevis.
- c. Tighten bolt (A).

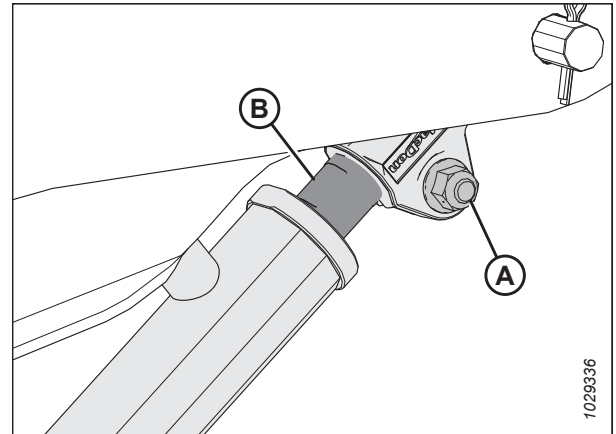

Figure 6.30: Outside Arm Cylinder

6. Repeat Step 5, page 227 on the opposite side of the header.
7. Loosen bolts (A) on both center arm cylinders.
8. Adjust the clearance as follows:

IMPORTANT:

Adjust both cylinder rods equally.

- To increase the clearance between the reel fingers and the cutterbar, turn cylinder rods (D) out of the clevis.
- To decrease the clearance between the reel fingers and the cutterbar, turn cylinder rods (D) into the clevis.

9. Ensure that measurement (B) is identical on both cylinders.

NOTE:

Measurement (B) runs from the center of mounting pins (C) to the tops of the notches in cylinder rods (D).

10. Ensure that both mounting pins (C) **CANNOT** be rotated by hand. If one of the mounting pins can be rotated, adjust cylinder rods (D) as needed:
 - Turn the cylinder rod out of the clevis to increase the load on the cylinder rod.
 - Turn the cylinder rod into the clevis to decrease the load on the cylinder rod.

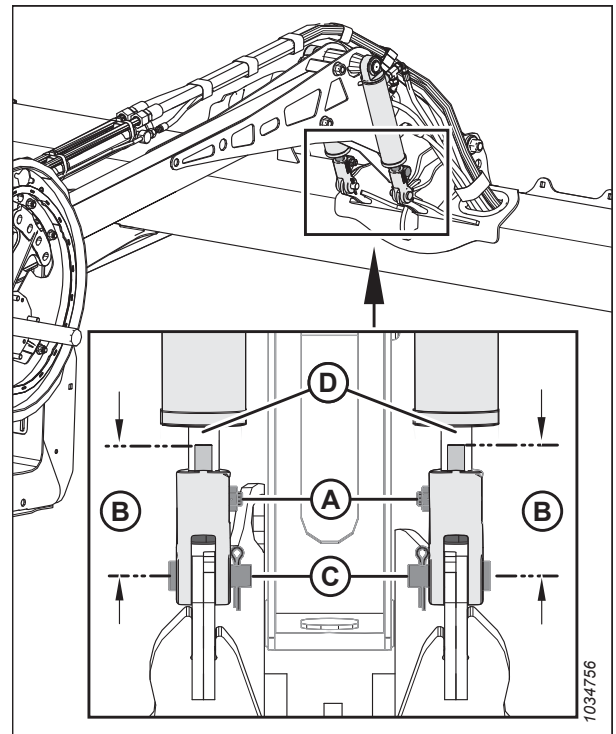

Figure 6.31: Center Arm Cylinders

11. Tighten bolts (A).
12. Start the engine.
13. Raise the reel fully.
14. Lower the reel fully and continue holding the control button down to phase the cylinders.

PERFORMING PREDELIVERY CHECKS

15. Shut down the engine, and remove the key from the ignition.
16. Check the reel-to-cutterbar clearance measurements again. If necessary, repeat the adjustment procedures.
17. Move the reel back to ensure that the reel fingers do not contact the deflector shields.
18. If the reel fingers contact the deflector shields, adjust the reel upward to maintain the clearance at all reel fore-aft positions. If contact still occurs after the reel is adjusted, trim the fingers as needed.
19. Periodically check for evidence of contact during operation. Adjust the reel-to-cutterbar clearance as needed.

6.10 Checking and Adjusting Header Float

The header is equipped with a suspension system that floats the header over the ground to compensate for changes in ground elevation. If the header float is not set properly, the cutterbar may scoop soil or it may leave crop uncut. If the float setting is not satisfactory, it will need to be inspected and adjusted.

IMPORTANT:

Do **NOT** use the float module springs to level the header.

When adjusting the float, use the following guidelines:

- Set the header float as light as possible, but not so light that the header bounces when the combine is moving. This will help prevent knife breakage, soil pushing, soil build-up at the cutterbar in wet conditions, and excessive wear to the skid shoes and cutterbar wearplates.
- To prevent the header from bouncing excessively and cutting unevenly when the float is light, operate the combine at a lower ground speed.
- To cut crop while the header is above ground level, use the stabilizer wheels in conjunction with the header float. This will minimize bouncing at the header ends and help regulate the cut height.

DANGER

Ensure that all bystanders have cleared the area.

DANGER

To prevent injury or death from the unexpected start-up of the machine, always stop the engine and remove the key from the ignition before leaving the operator's seat for any reason.

To check and adjust the float settings, do the following:

Preliminary steps

1. Park the combine on a level surface.
2. Ensure that the header is level with the ground. If adjustment is required, refer to [10.5 Leveling Header, page 526](#).

NOTE:

Spirit level (A) is located on top of the float module frame. The header is level if the bubble is in the center of the spirit level.

3. Position the header so that the cutterbar is 254–356 mm (10–14 in.) off the ground.

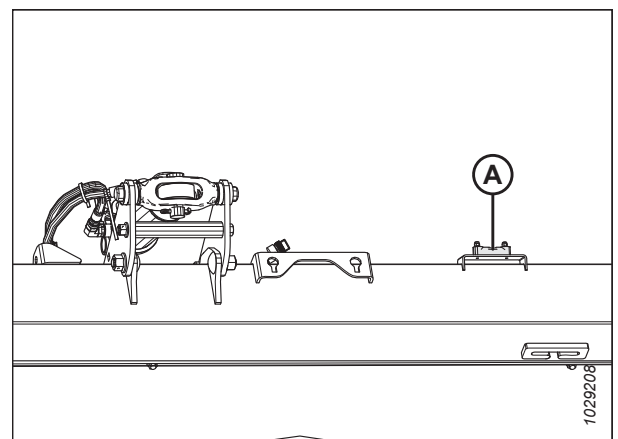

Figure 6.32: Spirit Level

PERFORMING PREDELIVERY CHECKS

- Adjust the reel fore-aft position so that the indicator on left indicator bracket (A) is at position 6.

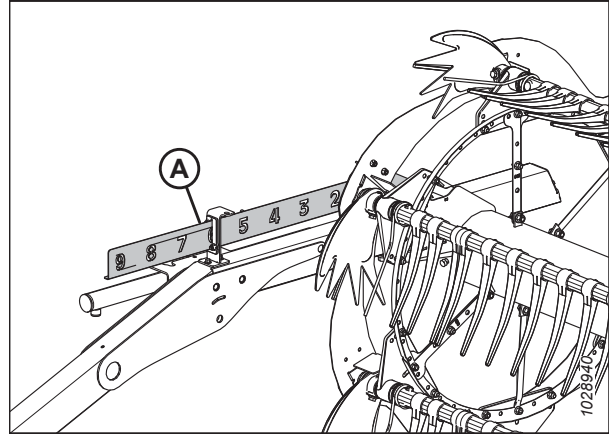

Figure 6.33: Fore-Aft Position

- Adjust center-link (A) so that indicator (B) is at position D on the gauge.
- Lower the reel fully.
- Shut down the engine, and remove the key from the ignition.
- If transport wheels are installed on the header, move them to the uppermost position.

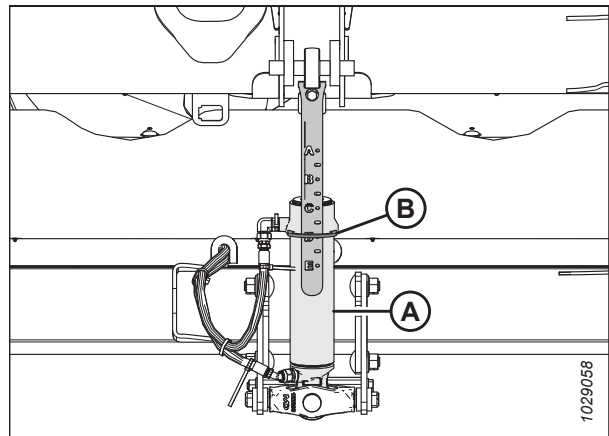

Figure 6.34: Center-Link

- If the pointer is not on zero, loosen bolt (A) and slide float indicator plate (B) until pointer (C) is on 0 (D). Tighten the nut on bolt (A).

NOTE:

Use zero dot (E) above the decal to correctly set the indicator needle.

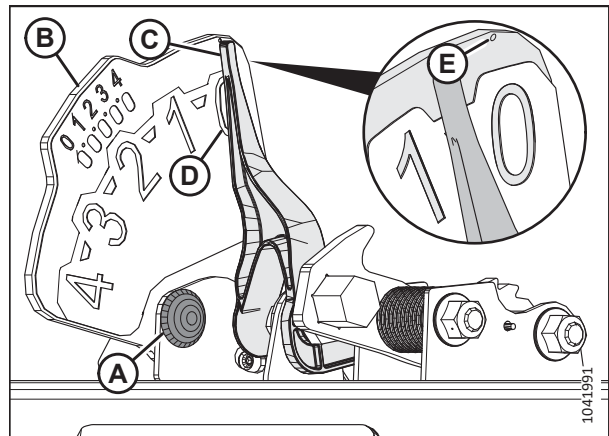

Figure 6.35: Float Indicator

PERFORMING PREDELIVERY CHECKS

10. On the left side of the float module, pull float lock handle (A) away from the float module, and pull the float lock handle down and into position (B) (UNLOCK).
11. Repeat the previous step on the right side of the float module.

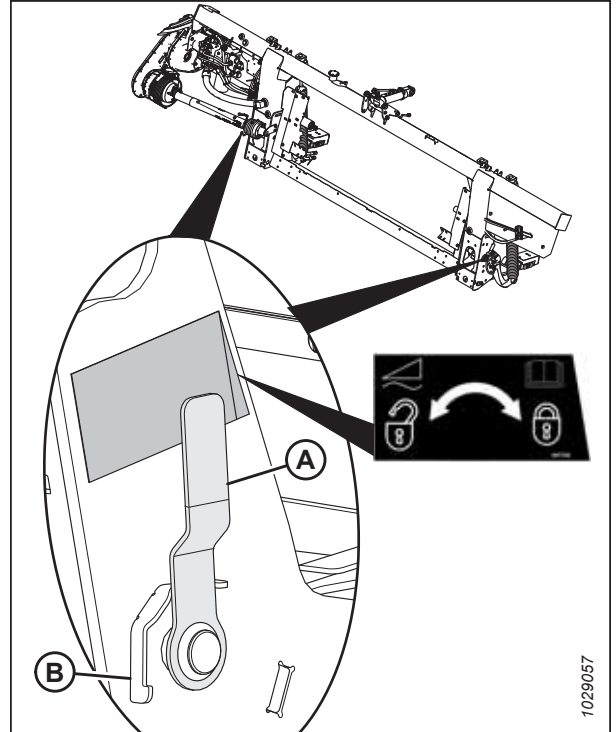

Figure 6.36: Header Float Lock in Locked Position

12. Open the left endshield.
13. Remove hairpin (A) securing multi-tool (B) to the bracket on the left endsheet.
14. Remove multi-tool (B). Replace the hairpin.

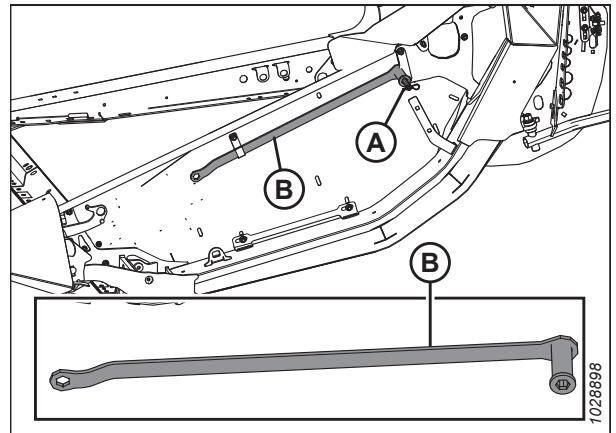

Figure 6.37: Multi-Tool Location

PERFORMING PREDELIVERY CHECKS

Setting the float setting levers

15. On the left side of the float module, lift float setting lever (A) by hand so that the lever is free of slack.

NOTE:

Some parts have been removed from the illustration for clarity.

16. Fully engage the flat end of multi-tool (B) onto the float setting lever. The multi-tool should be angled toward the front of the float module.
17. Pull multi-tool (B) toward the back of the float module until float setting lever (A) cannot be pulled back any further and it is locked into place on last tooth (C) of the lever.
18. Repeat Steps 15, page 232 to 17, page 232 to set the right float setting lever.

IMPORTANT:

Set both the left and the right float setting levers **BEFORE** adjusting the float on either side of the header.

19. Remove the multi-tool and set it aside.

Checking the float

20. Set the left float by pushing the left end of the header down by approximately 76 mm (3 in.). Allow the header to rise. Repeat this step at least three times.

NOTE:

Moving the left side of the header up and down ensures that the reading on the left indicator will be accurate.

21. On the left side of the float module, inspect upper scale on float setting indicator (FSI) (B). Arm (A) on the indicator should point to the number 2.

- If arm (A) on indicator (B) points to a value higher than 2, then the float is too heavy.
- If arm (A) on indicator (B) points to a value lower than 2, then the float is too light.

NOTE:

The lower set of numbers indicates the float height while the header is operating in the field.

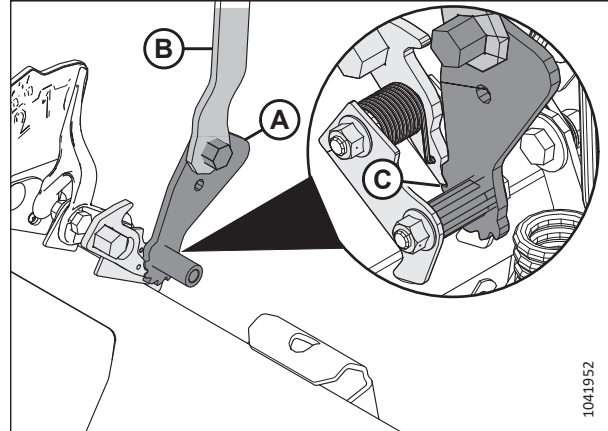

Figure 6.38: Multi-Tool Engaged with Left Float Setting Assembly

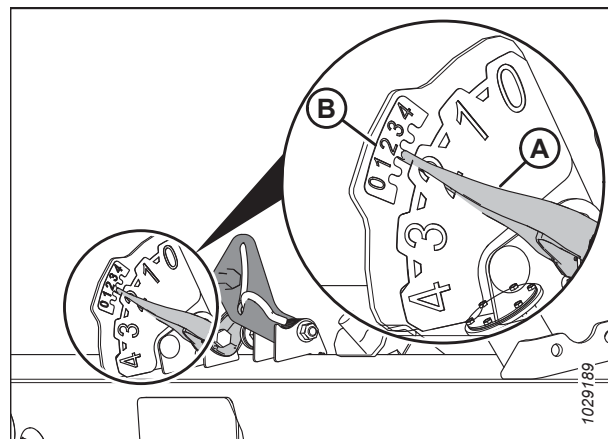

Figure 6.39: Left Float Setting and AHHC Indicator

Adjusting the float

22. On the left side of the float module, loosen bolts (C). Rotate spring locks (B) so that bolt heads (A) are accessible.
23. Increase or decrease the float on the left side of the float module as needed:
 - To make the header lighter (to increase the float), turn adjustment bolts (A) clockwise.
 - To make the header heavier (to decrease the float), turn adjustment bolts (A) counterclockwise.

NOTE:

Adjust each pair of bolts (A) by the same amount.

24. Set the left float again. Refer to Step 20, page 232 for instructions.
25. Check the left float setting indicator again. Refer to Step 21, page 232 for instructions.
26. If the left float setting is not satisfactory, repeat Step 23, page 233 to Step 25, page 233.
27. Check and adjust the right float. For instructions, refer to Step 20, page 232 to Step 26, page 233.

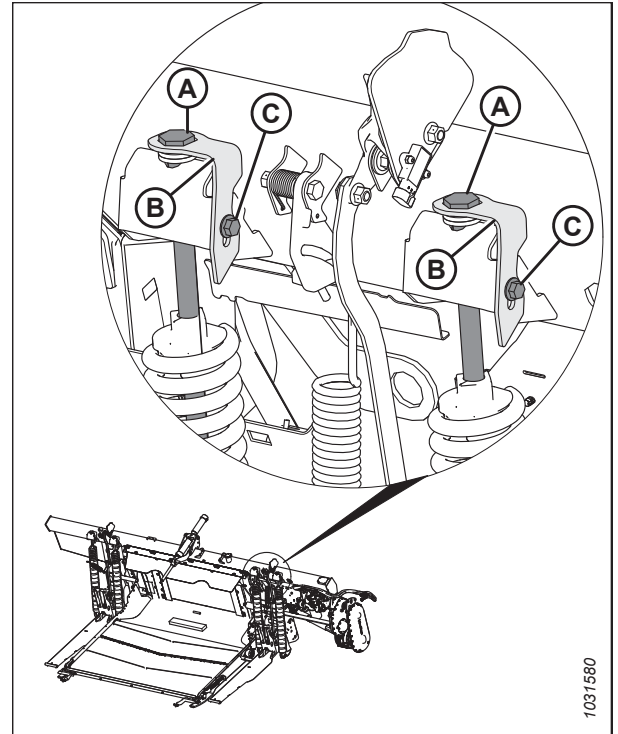

Figure 6.40: Left Float Adjustment

CAUTION

To prevent cuts, pinches, and other bodily harm to the person checking the down stops, ensure that nobody is manually lifting, bouncing, or moving the header in any way while the down stop washer is being touched and checked for movement.

28. Ensure that the float lock linkage is on the down stops (washer [A] cannot move) at both locations.

NOTE:

If the header is **NOT** on the down stops, the voltage may go out of range during operation and cause the AHHC system to malfunction. To fix the problem, make the header heavier by decreasing the float. For instructions, return to Step 23, page 233.

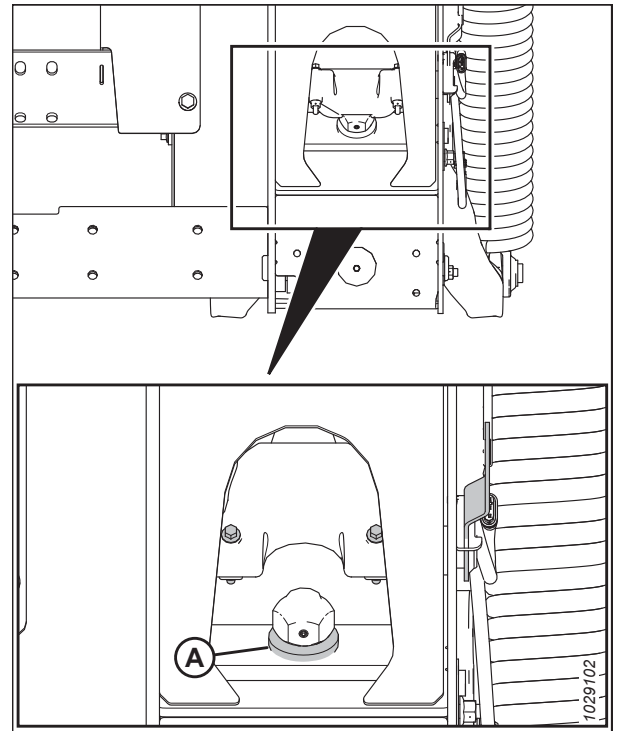

Figure 6.41: Down Stop Washer

PERFORMING PREDELIVERY CHECKS

29. On both sides of the float module, lock adjustment bolts (A) with spring locks (B). Ensure that bolt heads (A) are engaged in the spring lock cutouts. Tighten bolts (C) to secure the spring locks.

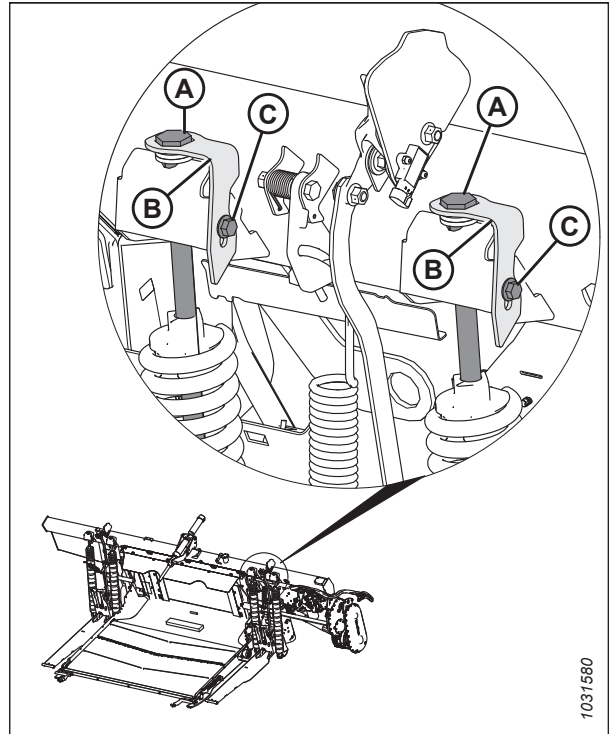

Figure 6.42: Left Float Adjustment

WARNING

Release the float setting lever before resuming operation.

Releasing the float setting levers

30. Fully engage multi-tool (C) onto pawl (B) and push it upward to release float setting lever (A).

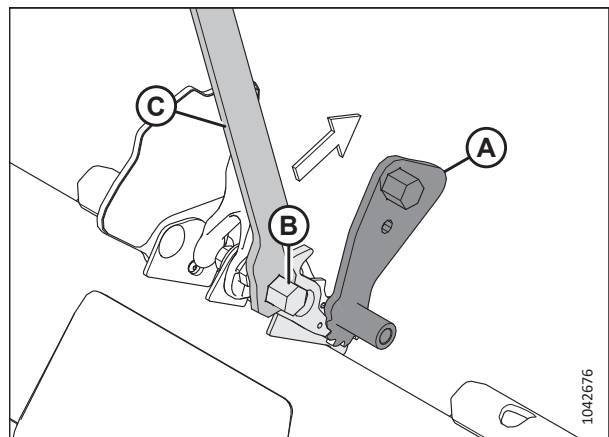

Figure 6.43: Multi-Tool Engaged with Left Pawl

6.11 Adjusting Feed-Auger-to-Pan Clearance

There must be an adequate clearance between the feed auger and the pan on the float module to ensure that the crop feeds smoothly.

DANGER

To prevent injury or death from the unexpected start-up of the machine, always stop the engine and remove the key from the ignition before leaving the operator's seat for any reason.

DANGER

Ensure that all bystanders have cleared the area.

IMPORTANT:

Maintain an appropriate distance between the feed auger and the feed auger pan. Too little of a clearance may result in the fingers or the flighting contacting and damaging the feed draper or the pan when operating the header at certain angles. Look for any evidence of contact when greasing the float module.

1. Extend the center-link to the steepest header angle (setting E), and position the header 254–356 mm (10–14 in.) off the ground.
2. Shut down the engine, and remove the key from the ignition.

CAUTION

To prevent cuts, pinches, and other bodily harm to the person checking the down stops, ensure that nobody is manually lifting, bouncing, or moving the header in any way while the down stop washer is being touched and checked for movement.

3. Ensure that the float lock linkage is on the down stops (washer [A] cannot move) at both locations.

NOTE:

If the header is **NOT** on the down stops, the voltage may go out of range during operation and cause the AHHC system to malfunction. To fix the problem, make the header heavier by decreasing the float. For instructions, refer to [6.10 Checking and Adjusting Header Float, page 229](#).

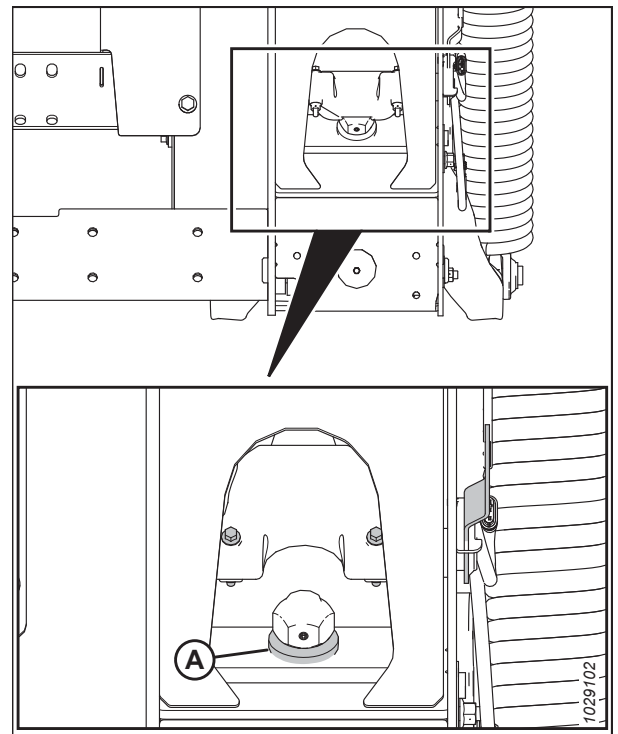

Figure 6.44: Down Stop Washer

PERFORMING PREDELIVERY CHECKS

- Before adjusting the auger-to-pan clearance, check the auger float position to determine how much of a clearance is required:

IMPORTANT:

Ensure that bolts (A) are set at the same location on both ends of the header to prevent damage to the machine during operation.

- If bolt head (A) is closest to floating symbol (B), the auger is in the floating position.

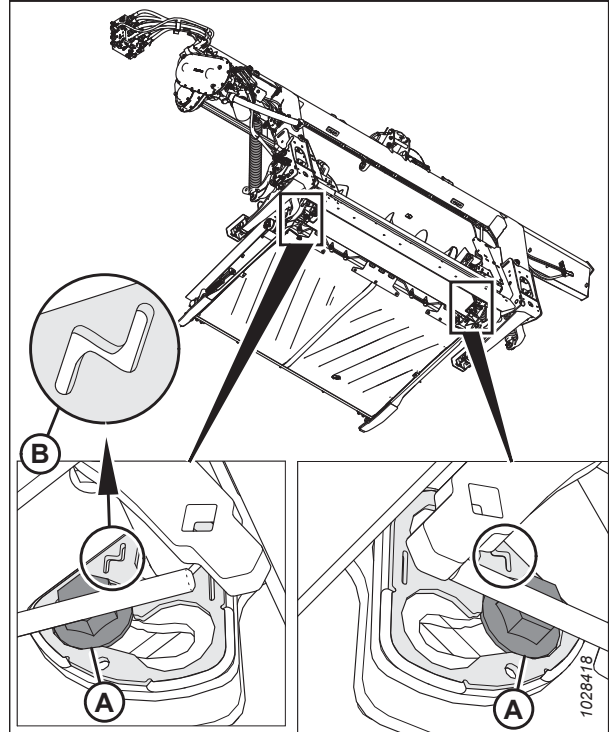

Figure 6.45: Floating Position

- If bolt head (A) is closest to fixed symbol (B), the auger is in the fixed position.

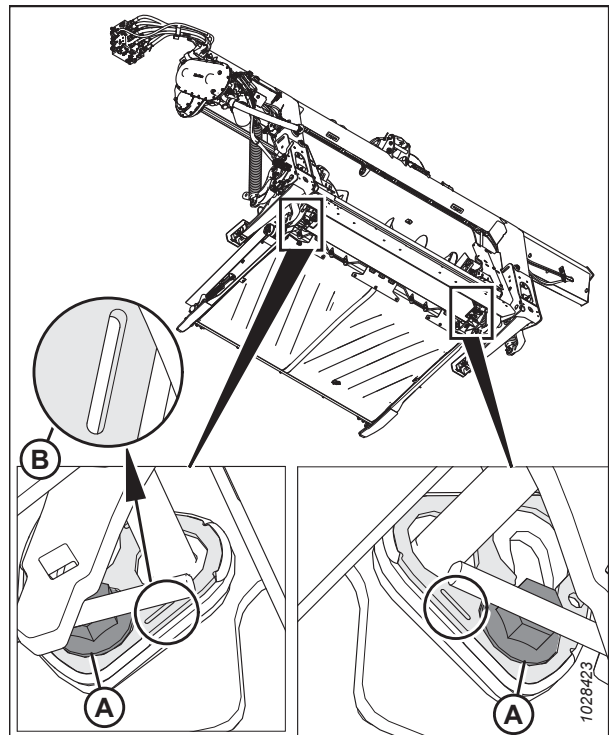

Figure 6.46: Fixed Position

PERFORMING PREDELIVERY CHECKS

5. Check clearance (C) between the feed auger flighting and the pan.
 - If the feed auger is in the fixed position, the clearance should be 24–28 mm (15/16–1 1/8 in.).
 - If the feed auger is in the floating position, the clearance should be 11.5–15.5 mm (7/16–5/8 in.).
6. If the clearance requires adjustment, loosen two nuts (B) and rotate the auger to position the flighting over the feed pan.
7. Turn bolt (A) clockwise to increase clearance (C); turn bolt (A) counterclockwise to decrease clearance (C).
 - If the feed auger is in the fixed position, set the clearance to 24–28 mm (15/16–1 1/8 in.).
 - If the feed auger is in the floating position, set the clearance to 11.5–15.5 mm (7/16–5/8 in.).

NOTE:

The clearance increases between 25–40 mm (1–1 1/2 in.) when the center-link is fully retracted.

8. Repeat Step 5, page 237 to Step 7, page 237 on the opposite end of the auger.

IMPORTANT:

Adjusting one side of the auger can affect the other side. Always double-check both sides of the auger after making final adjustments.

9. Tighten nuts (B) on both ends of the feed auger. Torque the nuts to 96 Nm (70 lbf-ft).
10. Rotate the feed auger and double-check the clearances.

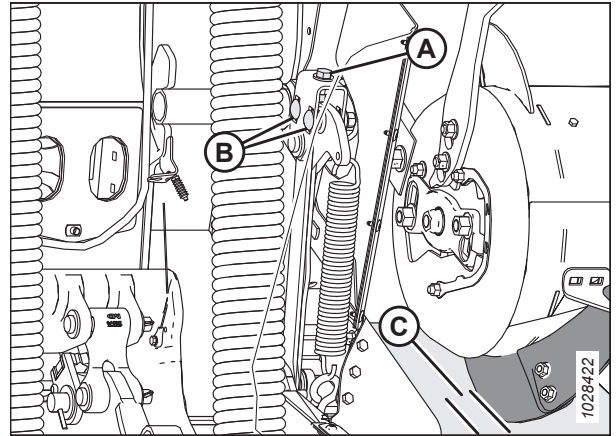

Figure 6.47: Auger Clearance

6.12 Checking and Adjusting Side Draper Tension

DANGER

To prevent bodily injury or death from the unexpected start-up or fall of a raised machine, always stop the engine, remove the key, and engage the vehicle's safety props before going under the machine for any reason.

DANGER

Ensure that all bystanders have cleared the area.

1. Ensure that tension indicator (A) covers the inboard half of the window.
2. Raise the header fully.
3. Shut down the engine, and remove the key from the ignition.
4. Engage the header safety props. For instructions, refer to the combine operator's manual.

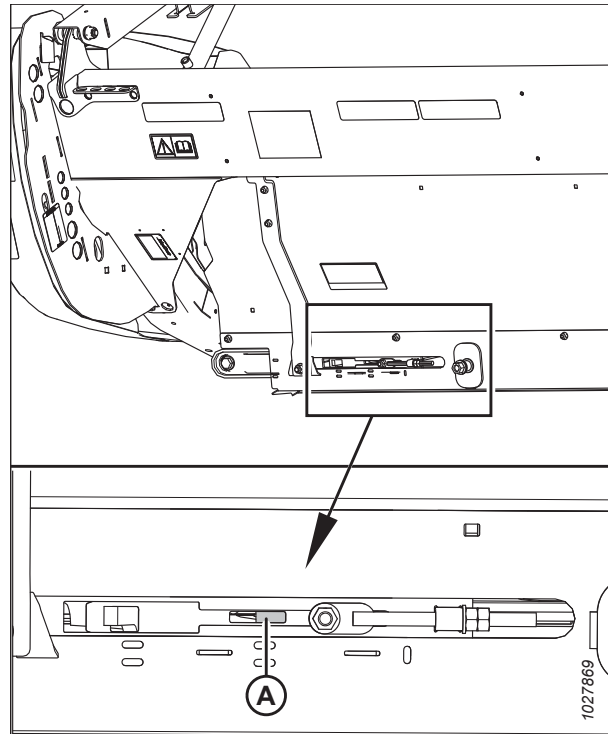

Figure 6.48: Checking Left Tension Adjuster

5. Ensure that the draper guide (the rubber track on the underside of the draper) is engaged in groove (A) of the drive roller.

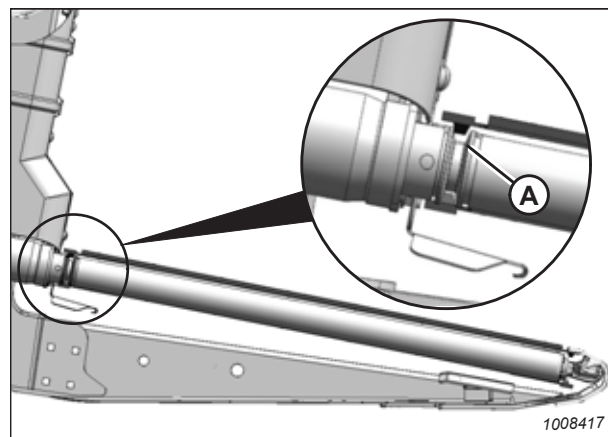

Figure 6.49: Drive Roller

PERFORMING PREDELIVERY CHECKS

6. Ensure that idler roller (A) is between guides (B).

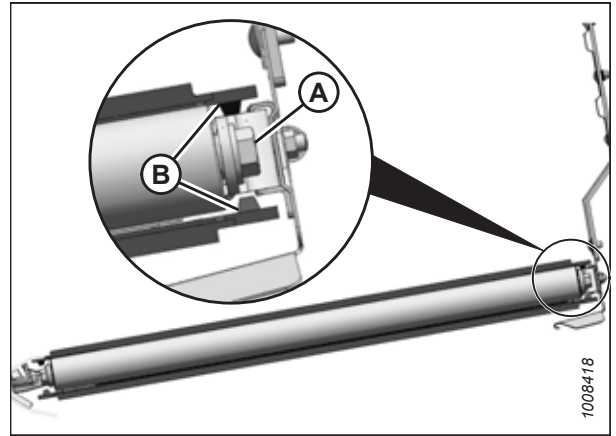

Figure 6.50: Idler Roller

7. Tighten adjuster bolt (A) until the tensioner indicator covers the inboard half of the window. Tensioner indicator (B) will move inboard to show that the draper is tightening.

IMPORTANT:

To avoid premature failure of the draper, draper rollers, and/or the tightener components, do **NOT** operate the header when the tension indicator is not visible.

IMPORTANT:

Do **NOT** adjust nut (C). This nut is used for draper alignment only.

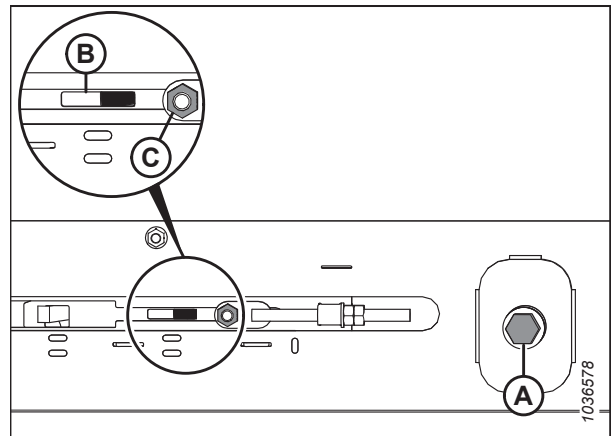

Figure 6.51: Adjusting Left Tensioner

6.13 Checking and Adjusting Draper Seal

Draper seal refers to the clearance between the draper belt and the cutterbar seal plate. A properly sealed draper should have as small a gap as possible between the draper and the cutterbar seal plate. If the draper seal is unsatisfactory, it will need to be adjusted.

Checking draper seal

DANGER

To prevent bodily injury or death from the unexpected start-up of the machine, always stop the engine and remove the key from the ignition before making adjustments to the machine.

DANGER

Ensure that all bystanders have cleared the area.

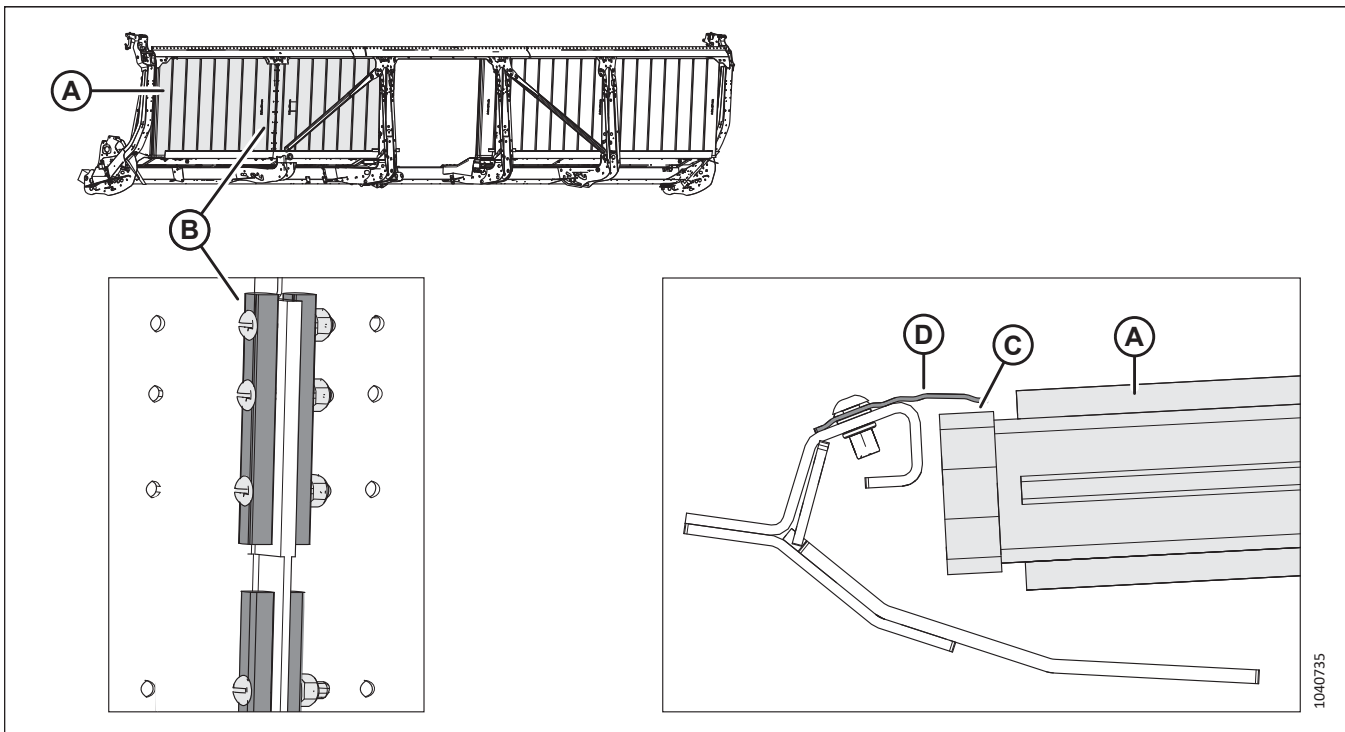

Figure 6.52: Draper Seal Clearance Specifications

1. Lower the header to the working position.
2. Move draper (A) so that connector bar (B) is on the bottom of the header.
3. Shut down the engine, and remove the key from the ignition.
4. Ensure that clearance (C) between draper (A) and metal seal (D) is 1–4 mm (0.04–0.16 in.).
5. If the clearance requires adjustment, proceed to the next step.

Adjusting draper seal

6. Release the tension on the draper. For instructions, refer to [6.12 Checking and Adjusting Side Draper Tension, page 238](#).

PERFORMING PREDELIVERY CHECKS

7. Lift the front edge of draper (A) past cutterbar (B) to expose the front hook.
8. Measure the thickness of the draper belt.

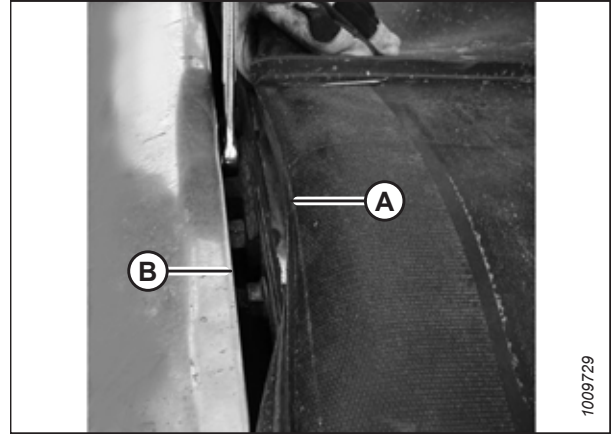

Figure 6.53: Deck Front Hook

9. Remove screws (B) and cutterbar seal (A) above the cutterbar.

NOTE:

This step is not strictly necessary, but performing it allows better access to the front hooks.

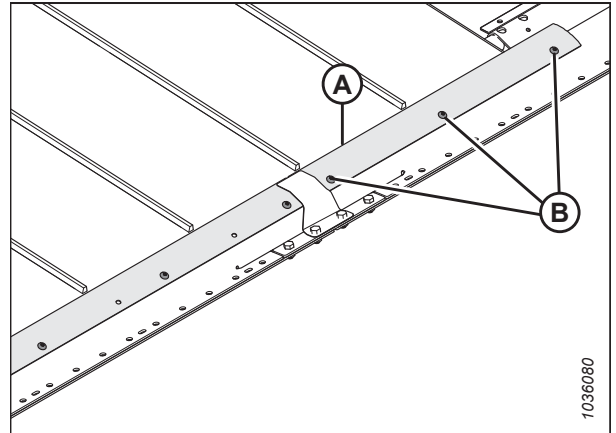

Figure 6.54: Deck Seal Plate

NOTE:

The draper deck is supported by deck front hooks (A). The header width determines the number of hooks:

Table 6.4 Number of Deck Support Hooks

Model	Quantity
D225 and D230	6
D235	8

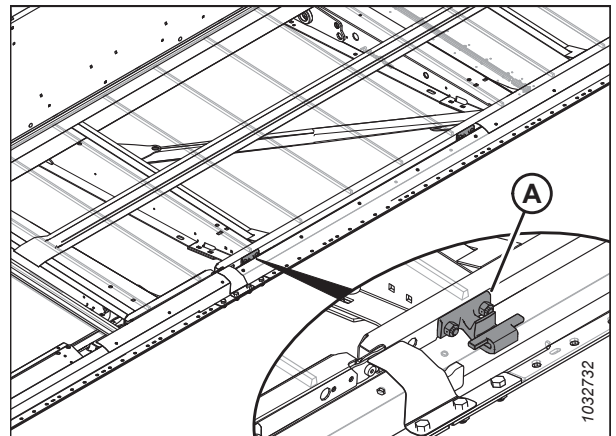

Figure 6.55: Draper Deck Front Hooks

PERFORMING PREDELIVERY CHECKS

- Loosen two lock nuts (A) on deck front hook (B) by one half-turn **ONLY**.
- Tap deck (C) with a hammer and a block of wood to lower the deck relative to the deck front hooks. Tap deck front hook (B) using a punch to raise the deck relative to the deck front hooks.

NOTE:

The deck is shown with parts removed for clarity.

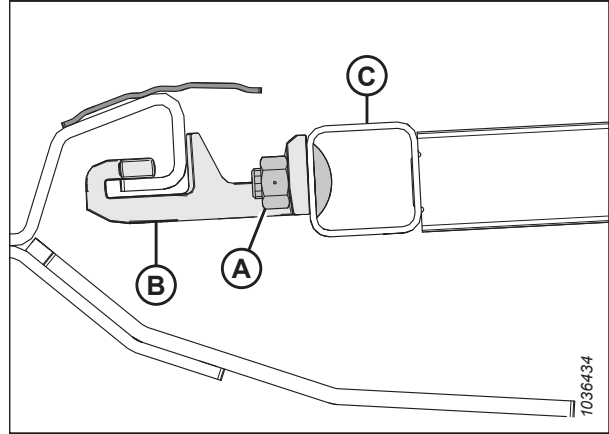

Figure 6.56: Deck Support

- Use a feeler gauge of the same thickness as the draper belt, plus 1 mm (0.04 in.). Slide the feeler gauge along deck (A) under cutterbar seal plate (C) to set the clearance.
- To create a seal, adjust deck (A) so that clearance (B) between cutterbar seal plate (C) and the deck is the same as the thickness as the draper belt plus 1 mm (0.04 in.).

NOTE:

To check the clearance at a draper roller, measure from the roller tube, **NOT** the deck.

- Tighten hardware (D).
- Measure gap (B) again using the feeler gauge. For instructions, refer to Step 12, page 242.
- If removed, install cutterbar seal (A) and screws (B).

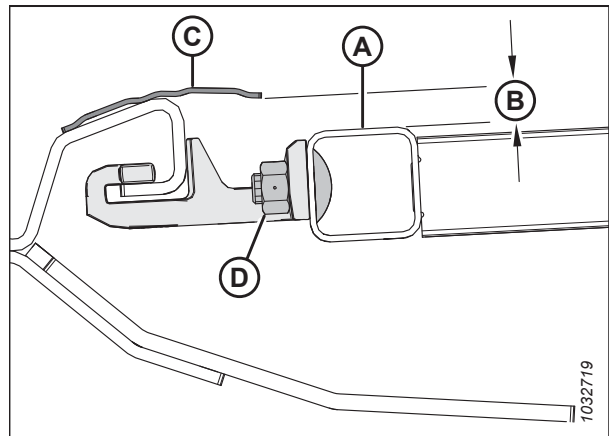

Figure 6.57: Deck Front Hook

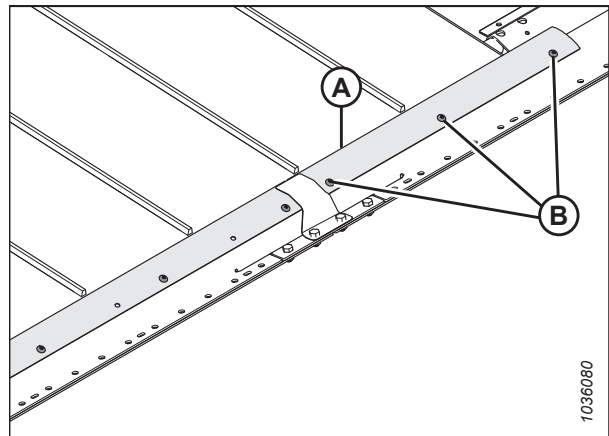

Figure 6.58: Deck Seal Plate

6.14 Lubricating Header

All of the lubrication points on the header will need to be inspected to ensure that they can accept grease.

Use the proper lubricant for the application. Refer to the table below for information on the type of lubricant to use:

Table 6.5 Recommended Lubricant

Lubricant Specification	Description	Application
SAE multipurpose	High temperature, extreme pressure (EP) performance with 10% max. molybdenum disulphide (NLGI Grade 2) lithium base	Driveline slip-joints
SAE multipurpose	High temperature, extreme pressure (EP2) performance with 1% max. molybdenum disulphide (NLGI Grade 2) lithium base	All other lubrication points

6.14.1 Greasing Procedure

Greasing points are identified on the machine by decals showing a grease gun and grease interval in hours of operation. Grease point layout decals are located on the header and on the right side of the float module.

DANGER

To prevent injury or death from the unexpected start-up of the machine, always stop the engine and remove the key from the ignition before leaving the operator's seat for any reason.

1. Before lubricating a grease fitting, wipe it with a clean cloth to avoid injecting dirt and grit into the fitting.

IMPORTANT:

Use clean, high-temperature, extreme-pressure grease only.

2. Inject the grease through the fitting with a grease gun until the grease overflows the fitting (except where noted).
3. Leave the excess grease on the fitting to keep the dirt out.
4. Replace any loose or broken grease fittings immediately.
5. Remove and thoroughly clean any fitting that will not take grease. Clean the lubricant passageway. Replace the fitting if necessary.

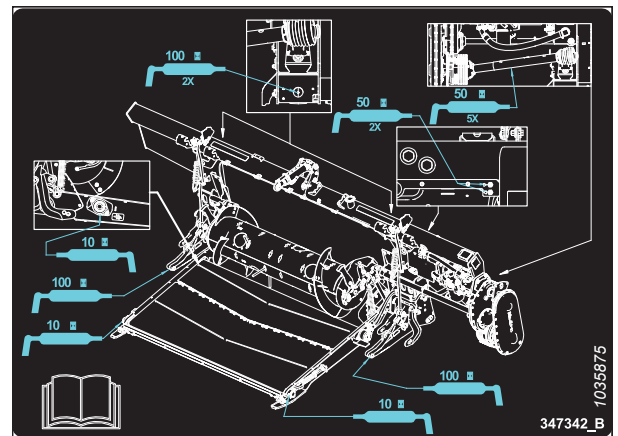

Figure 6.59: FM200 Grease Point Layout Decal

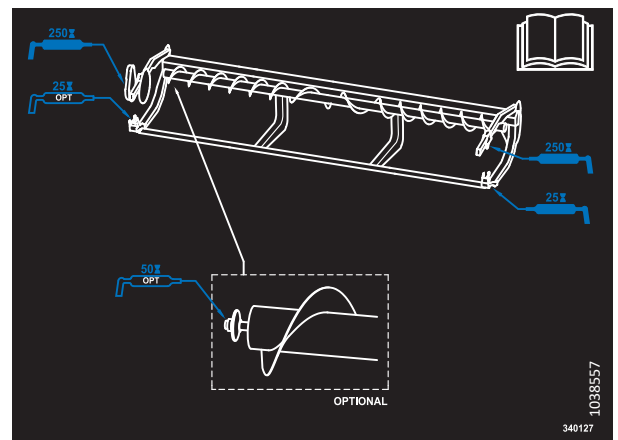

Figure 6.60: Grease Point Decal for Single-Knife Header with One-Piece Upper Cross Auger

PERFORMING PREDELIVERY CHECKS

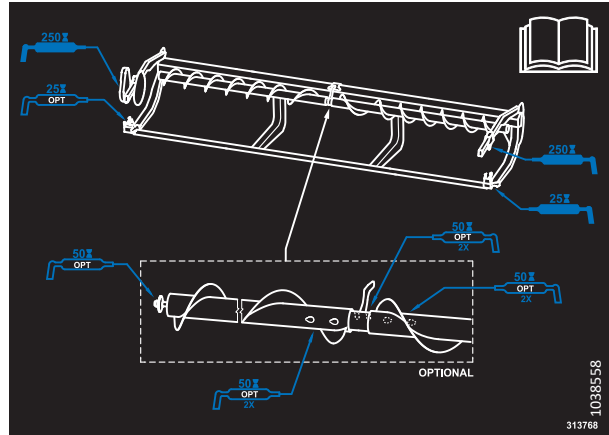

Figure 6.61: Decal for Single-Knife Header with Two-Piece Upper Cross Auger

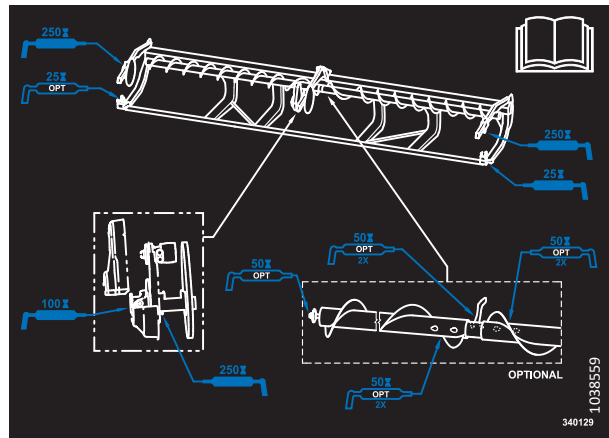

Figure 6.62: Decal for Double-Knife Header with Two-Piece Upper Cross Auger

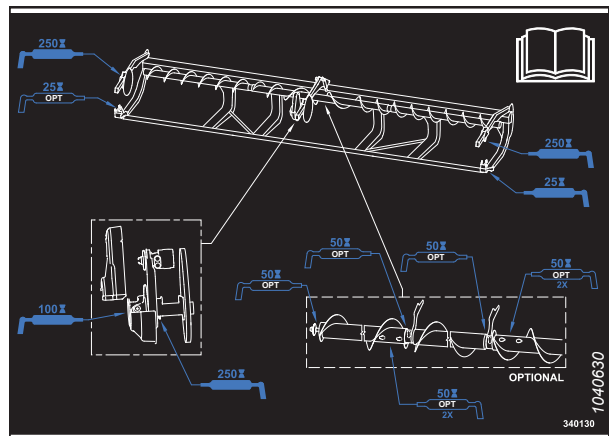

Figure 6.63: Decal for Double-Knife Header with Three-Piece Upper Cross Auger

6.14.2 Lubrication Points

There are several points on the header which will require lubrication.

Lubricate the following grease points using the lubricants specified in [6.14 Lubricating Header, page 243](#):

IMPORTANT:

Feeder draper drive roller grease zerk (A) and idler roller grease zerk (B): Clear any debris and excess grease from around the bearing and bearing housing. Inspect the condition of the bearing and bearing housing. Grease the feed draper drive roller bearing until grease comes out of the seal. Wipe any excess grease from the area after greasing. Initial greasing on a new header may require additional grease (may require 5–10 pumps). Wipe any excess grease from the area after greasing.

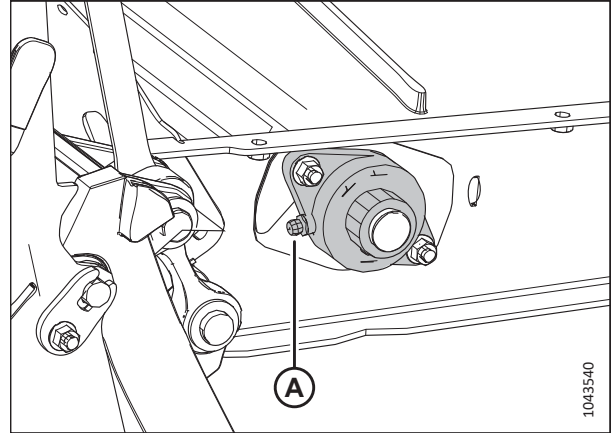

Figure 6.64: Feed Draper Drive Roller

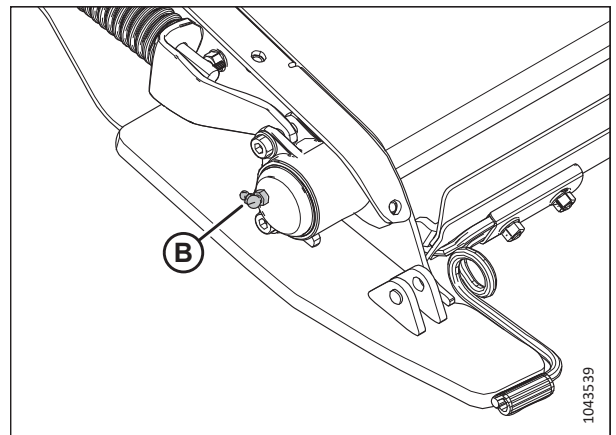

Figure 6.65: Feed Draper Idler Roller

PERFORMING PREDELIVERY CHECKS

NOTE:

There is one knifehead on a single-knife header and two on a double-knife header.

IMPORTANT:

Knifehead grease zerk (A): Overgreasing the knife can cause the knife to bend and make contact with the guards closest to the knifehead. Check for signs of excessive heating on the first few guards after applying grease. If necessary, relieve some of the pressure by removing the grease fitting.

- When greasing for the first time, ensure that the cavity is full of grease, and that movement is not being caused by trapped air in the bearing.
- To prevent binding and/or excessive wear caused by the knife pressing on the guards, do **NOT** overgrease the knifehead.
- Apply only one to two pumps of grease with a grease gun, or just until the knifehead starts to move away from the arm. Do **NOT** use an electric grease gun.
- If more than six to eight pumps of the grease gun are required to fill the cavity, replace the seal in the knifehead.

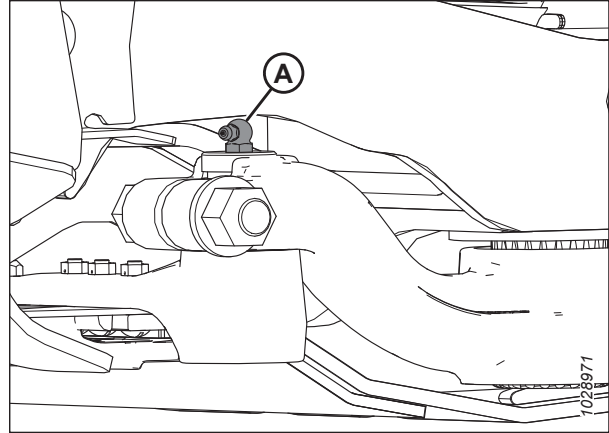

Figure 6.66: Knifehead

PERFORMING PREDELIVERY CHECKS

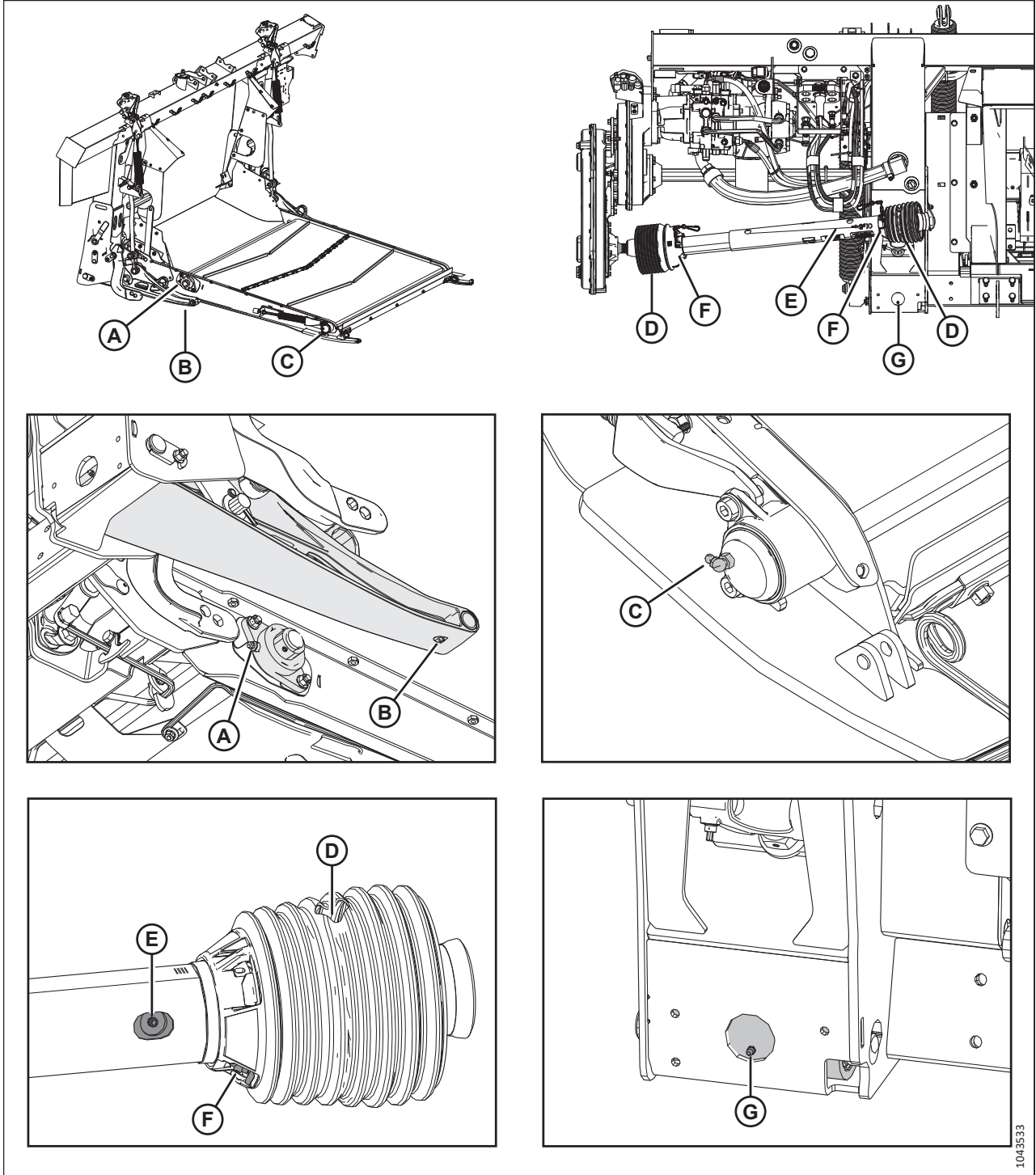

Figure 6.67: Float Module Grease Zerks – Feed Draper and Gearbox

- A - Drive Roller Bearing
- C - Idler Roller Bearing (Two Places)
- E - Driveline Slip Joint
- G - Float Pivots (Right and Left)

- B - Lower Link Bearing (Two Places)
- D - Driveline Universal (Two Places)
- F - Driveline Guards (Two Places)

PERFORMING PREDELIVERY CHECKS

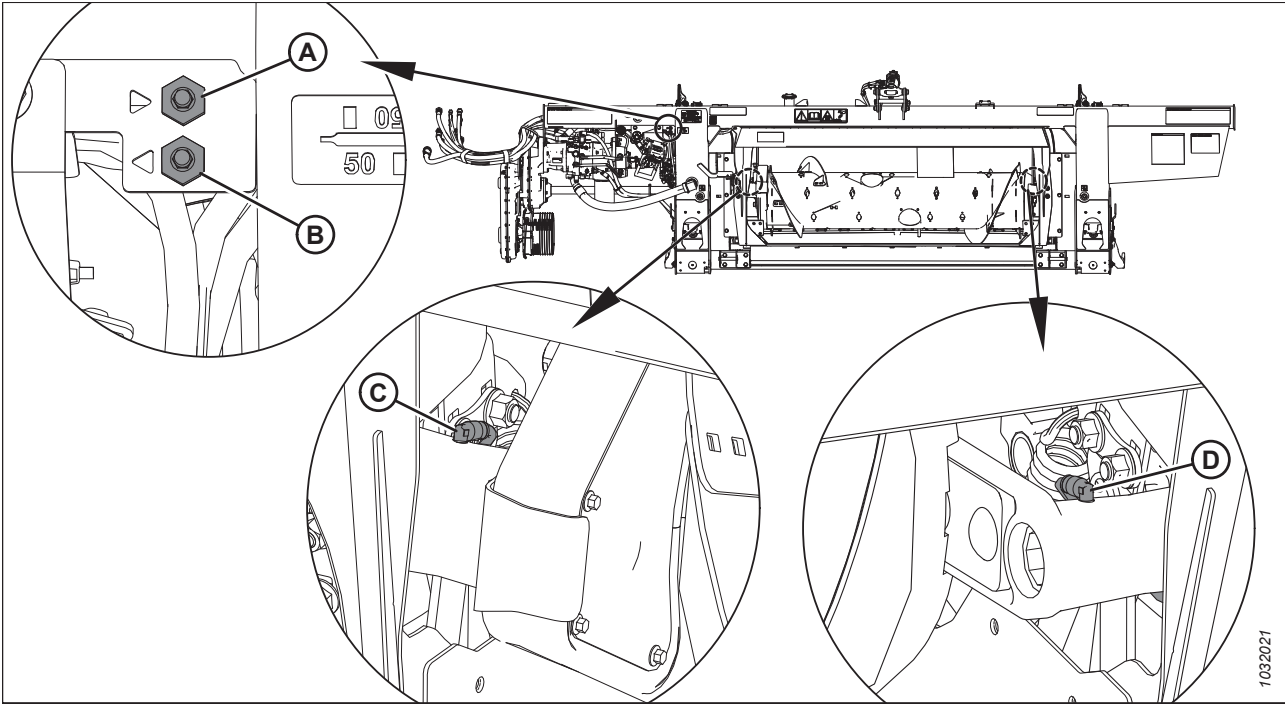

Figure 6.68: Float Module Grease Zerks – Auger

A - Remote Grease Line for Auger Pivot (Right Side)
C - Auger Pivot (Left Side)

B - Remote Grease Line for Auger Pivot (Left Side)
D - Auger Pivot (Right Side)

PERFORMING PREDELIVERY CHECKS

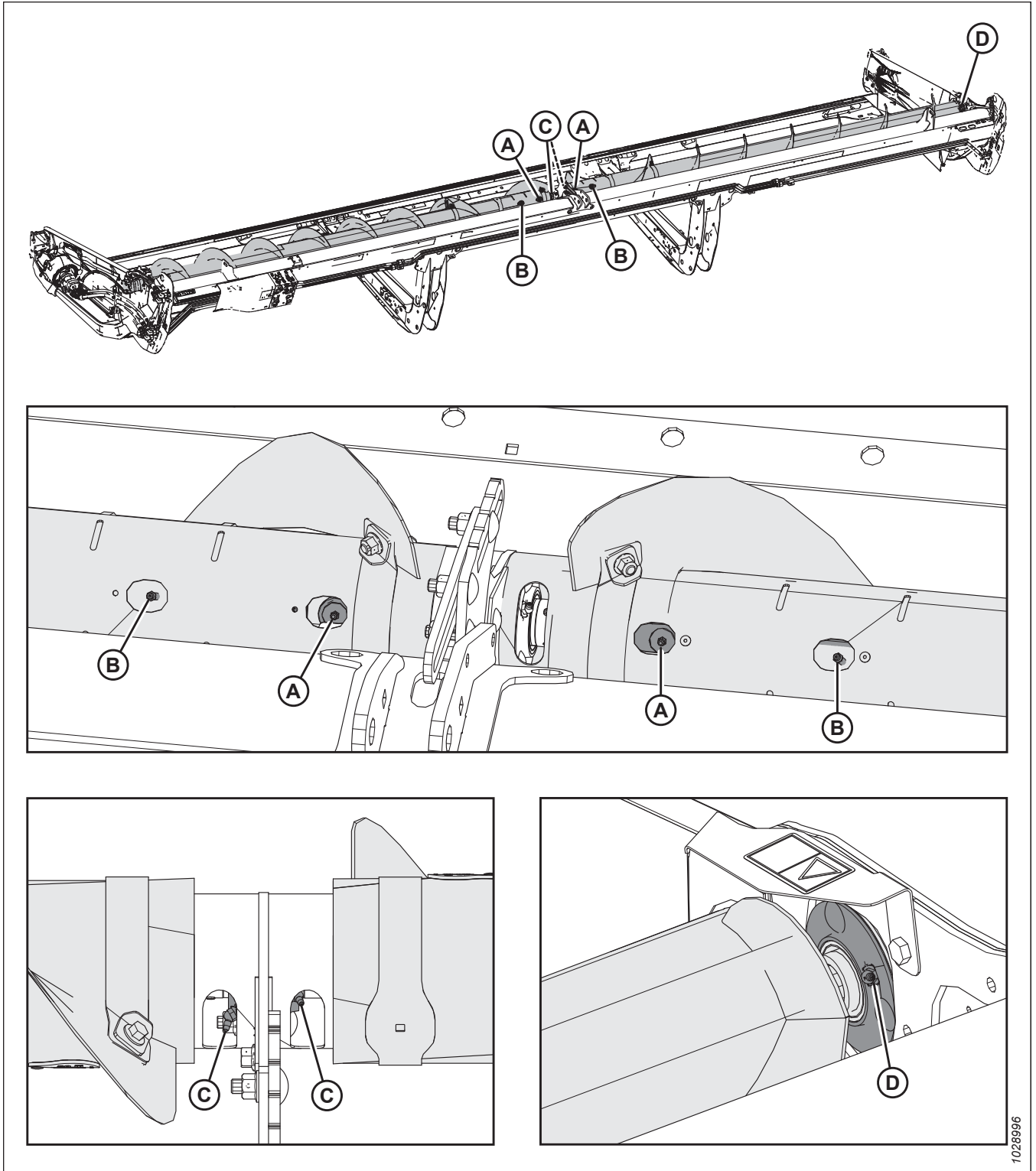
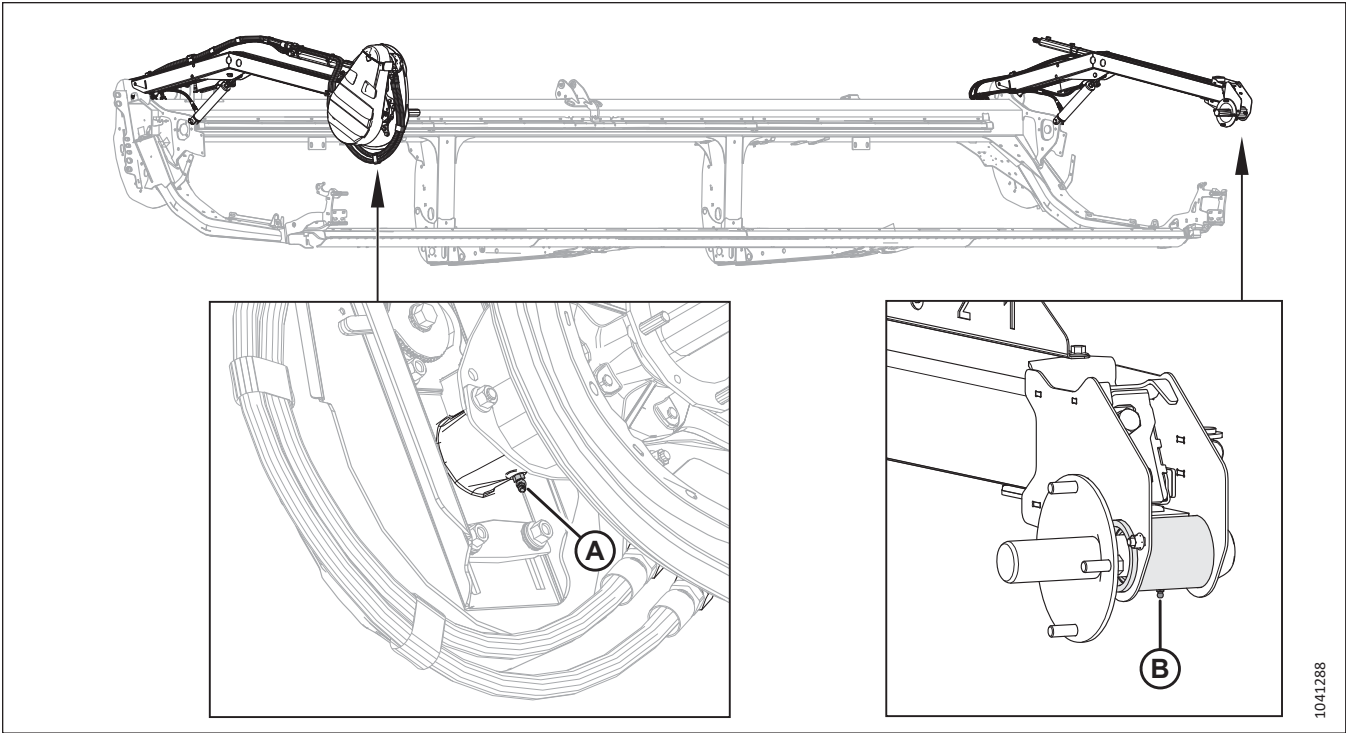

Figure 6.69: Grease Zerks – Two-Piece Upper Cross Auger

- A - Upper Cross Auger U-joints (Two Places)
- C - Upper Cross Auger Center Bearings (Two Places)

- B - Upper Cross Auger Sliding Hubs (Two Places)
- D - Right End Bearing

PERFORMING PREDELIVERY CHECKS



1041288

Figure 6.70: Single Reel

A - Reel Right Bearing (One Place)

B - Reel Left Bearing (One Place)

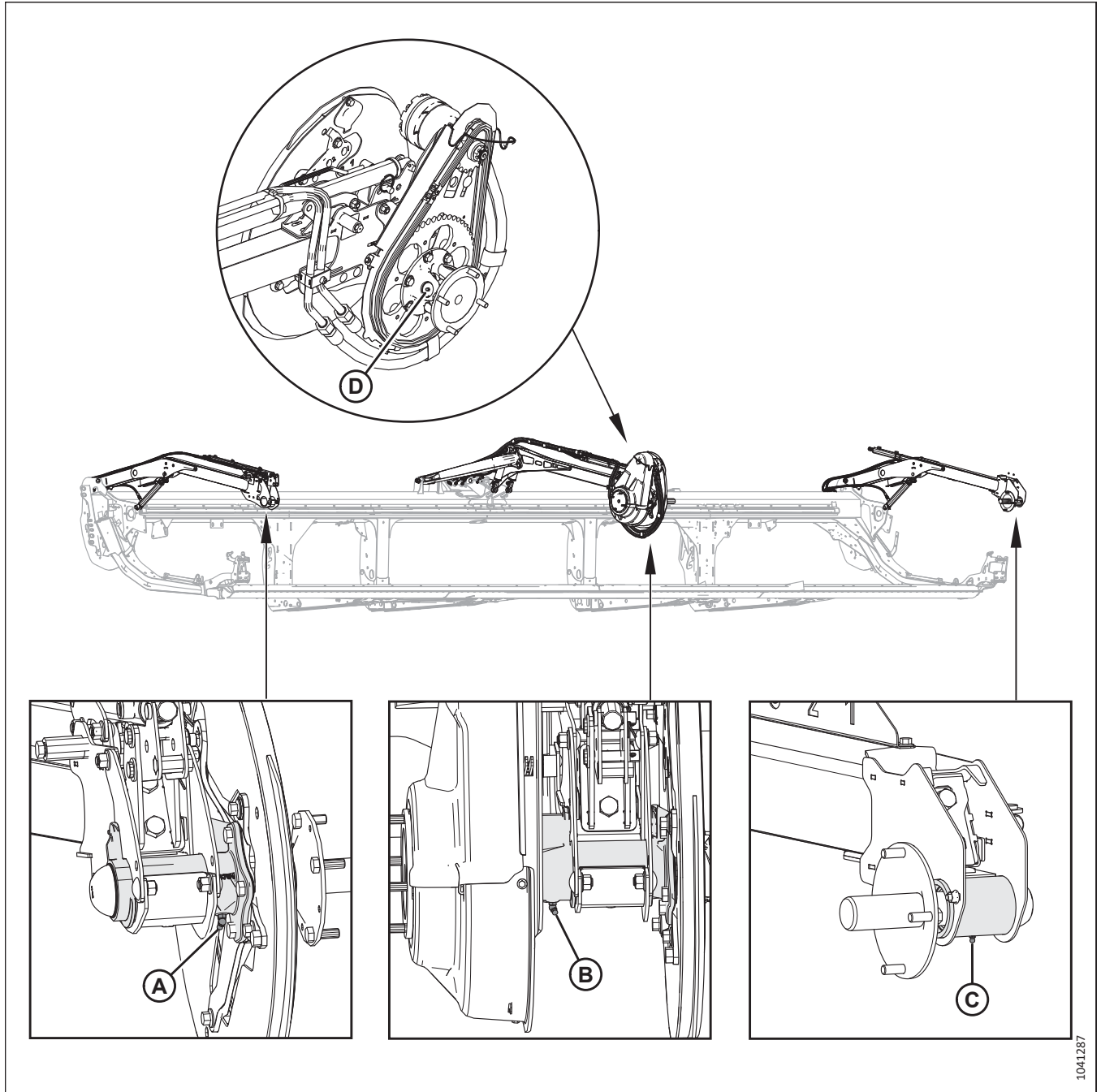

Figure 6.71: Double Reel

A - Reel Right Bearing (One Place)
 D - Reel U-joint (One Place)²⁰

B - Reel Center Bearing (One Place)

C - Reel Left Bearing (One Place)

1041287

20. The U-joint has an extended lubrication cross and bearing kit. Stop greasing when greasing becomes difficult or if the U-joint stops taking grease. Overgreasing will damage the U-joint. Six to eight pumps are sufficient at first grease (factory). Decrease the greasing interval as the U-joint wears and requires more than six pumps.

PERFORMING PREDELIVERY CHECKS

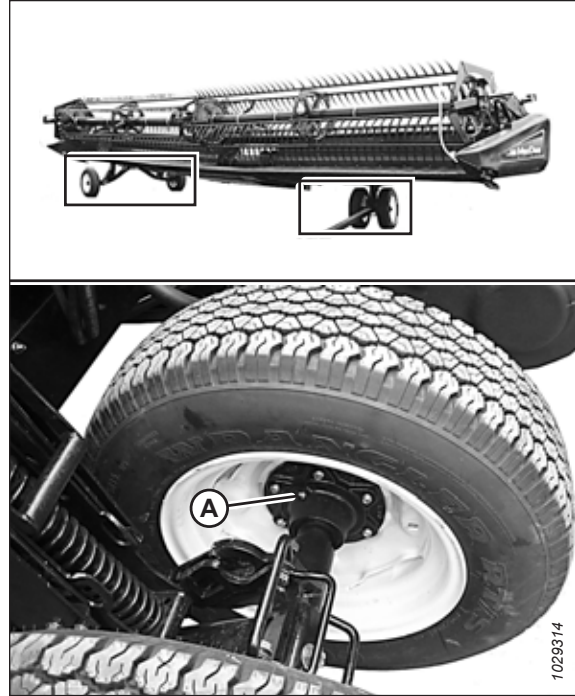

Figure 6.72: Transport Wheel Bearings

A - Wheel Bearings (Four Places)

6.15 Checking and Adjusting Header Endshields

The header endshields can warp due to extreme changes in temperature. Adjust the position of the header endshield to compensate for dimensional changes.

DANGER

To prevent bodily injury or death from the unexpected start-up of the machine, always stop the engine and remove the key from the ignition before leaving the operator's seat for any reason.

1. Shut down the engine, and remove the key from the ignition.

IMPORTANT:

Ensure that the header endshield does **NOT** rest on the aluminum endsheet.

2. Measure clearance (A) between header endshield (B) and endsheet (C). The clearance should be 1–3 mm (1/16–1/8 in.).

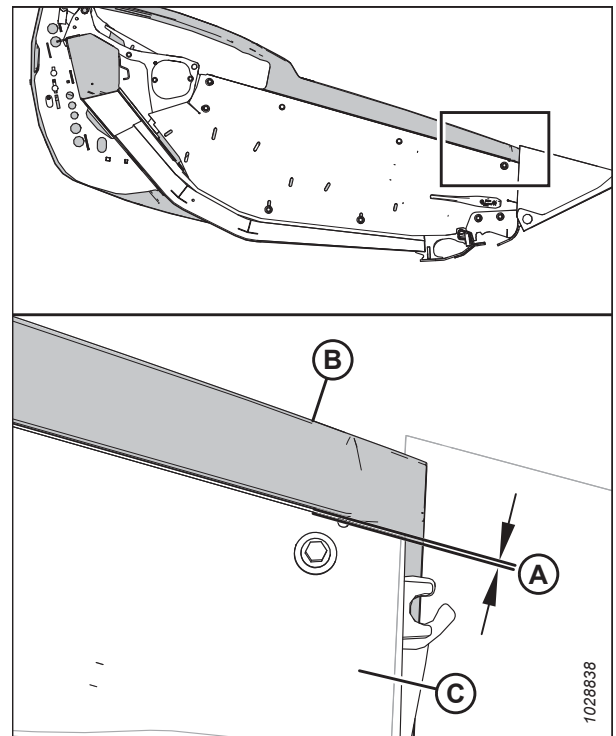

Figure 6.73: Clearance between Endshield and Endsheet

PERFORMING PREDELIVERY CHECKS

3. If the clearance between the header endshield and the endsheet is insufficient, adjust support bracket (A) as follows:
 - a. Loosen bolts (B).
 - b. Move support bracket (A) up or down as needed.
 - c. Retighten the hardware.

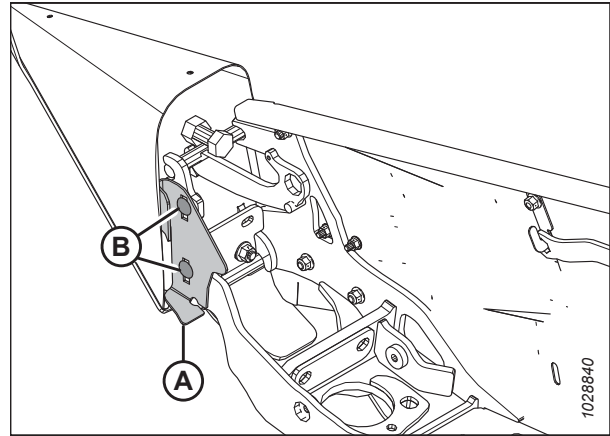

Figure 6.74: Header Endshield Support Bracket

PERFORMING PREDELIVERY CHECKS

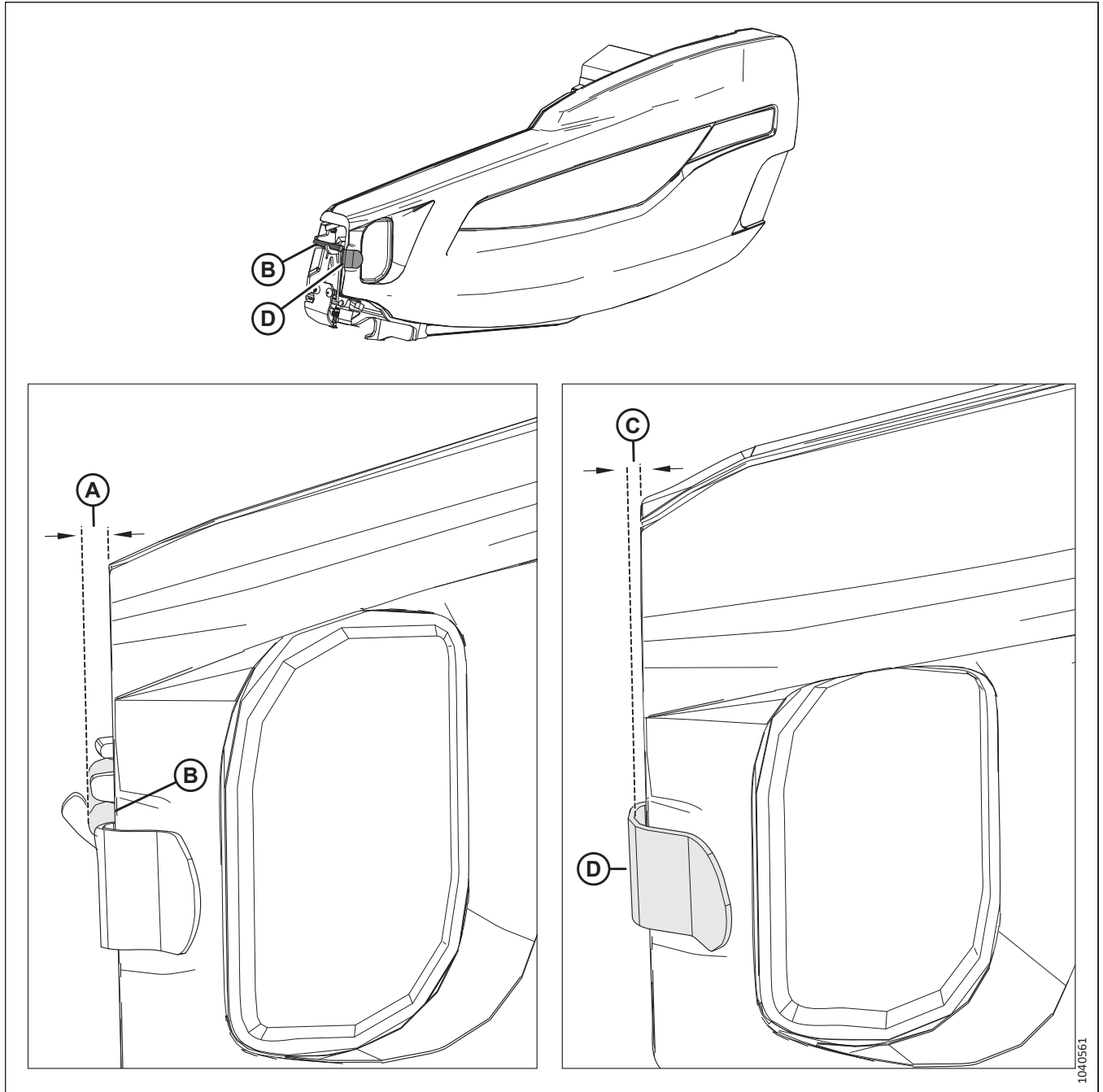

Figure 6.75: Clearance Specifications at the Front of the Endshield

4. Measure clearance (A) between the front of the header endshield and pin (B). The clearance should be 8–18 mm (1/32–11/16 in.).
5. Measure clearance (C) between the front of the header endshield and support bracket (D). The clearance should be 6–10 mm (1/4–3/8 in.).

PERFORMING PREDELIVERY CHECKS

6. If the clearances at the front of the endshield are insufficient, adjust the position of hinge arm (A) as follows:
 - a. Loosen four nuts (B).
 - b. Slide brackets (C) and hinge arm (A) fore or aft as required to achieve the correct clearance.
 - c. Retighten the hardware.

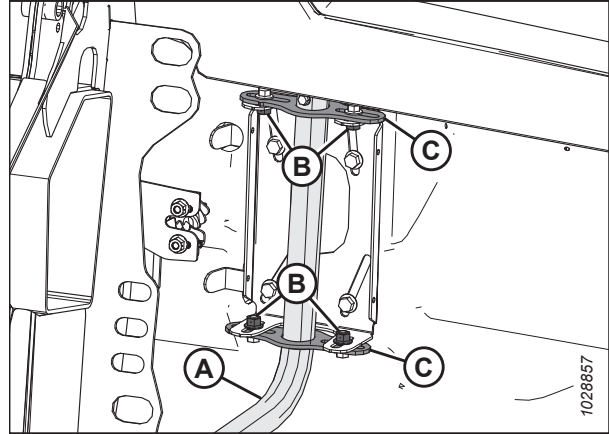

Figure 6.76: Left Header Endshield

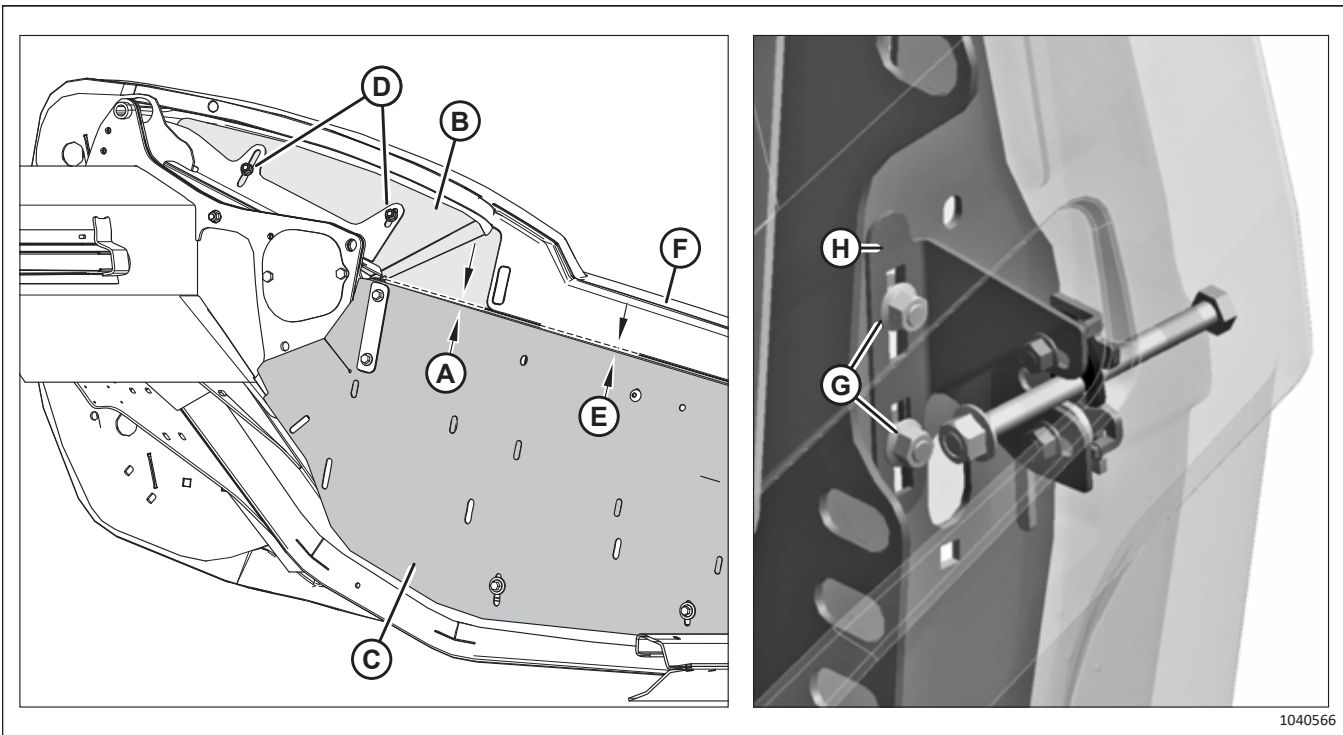

Figure 6.77: Clearance Specification between Neck Shield and End Panel

7. Measure clearance (A) between neck shield (B) and end panel (C). The clearance must be at least 3 mm (1/8 in.). To adjust the clearance, loosen two nuts (D), move neck panel (B), and tighten nuts (D).
8. Measure clearance (E) between end panel (C) and endshield (F). The clearance must be 1–3 mm (1/16–1/8 in.). To adjust the clearance, loosen two nuts (G), slide bracket (H) up or down, and tighten the nuts.

NOTE:

Ensure that the endshield does **NOT** rest on neck panel (B).

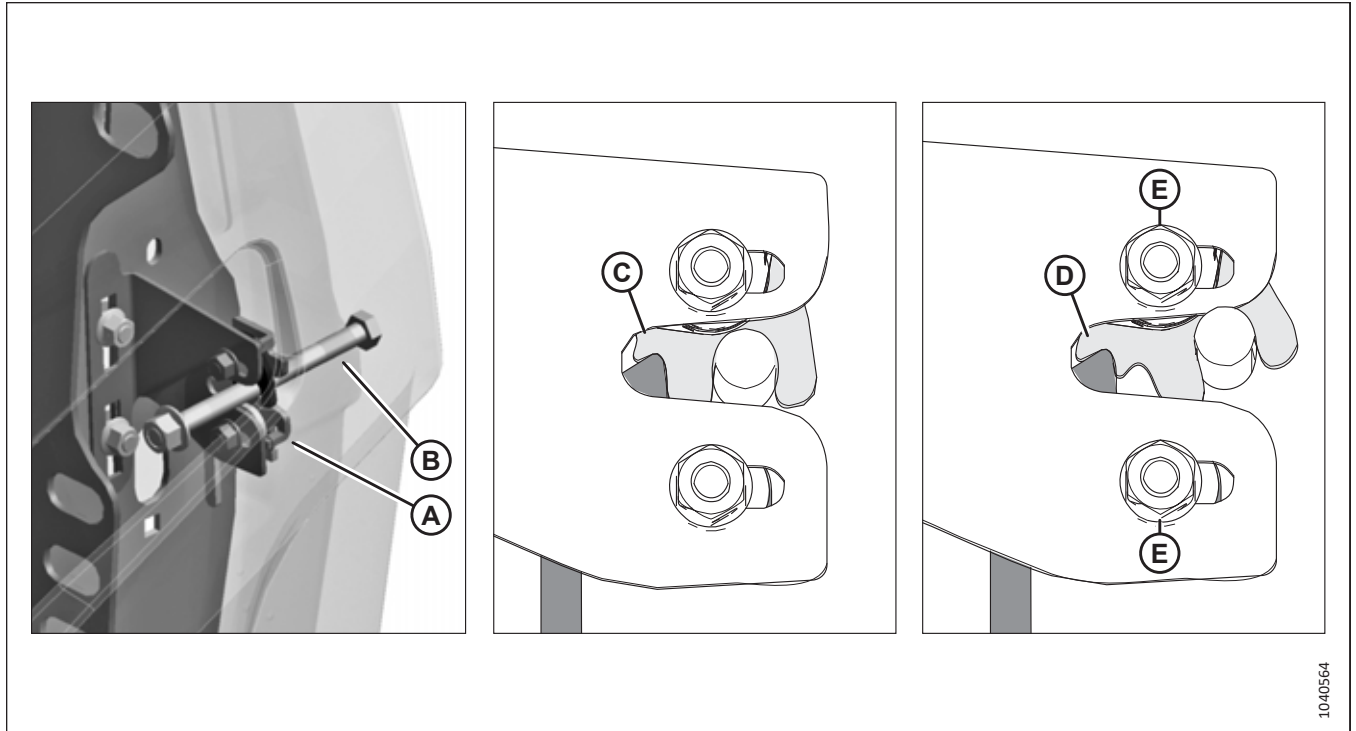

Figure 6.78: Two-Stage Latch

9. When the endshield is closed, two-stage latch (A) must engage first catch (C). This will allow second catch (D) to prevent the endshield from opening completely in case the endshield unlatches by accident. Confirm the endshield latches properly by following Step [10, page 257](#) to Step [12, page 257](#).
10. Close the endshield. Confirm bolt (B) engages latch (A).
11. Release the latch.
12. Try to open the endshield.
 - If you can open the endshield partially, but **NOT** completely, then the latch is positioned properly.
 - If you can open the endshield completely, loosen nuts (E), move latch along the slotted holes, then retighten the nuts. Repeat Step [10, page 257](#) to Step [12, page 257](#).

6.16 Checking Manuals

Check the manual case contents. On D225 Draper Headers, the manual storage case is located at the rear of the header, inboard of the left endsheet. On the larger draper headers, the manual storage case is located at the rear of the header, outboard of the right outer leg.

1. Remove the cable tie on manual case (A).
2. Confirm that the case contains the following manuals:
 - D2 Series Draper Header for Combine Operator's Manual
 - D2 Series Draper Header for Combine Quick Card
 - D2 Series Draper Header for Combine Parts Catalog
3. Close the manual storage case.

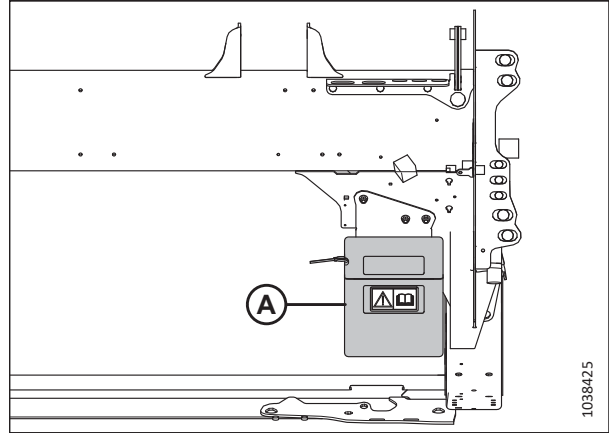

Figure 6.79: Manual Case – D225

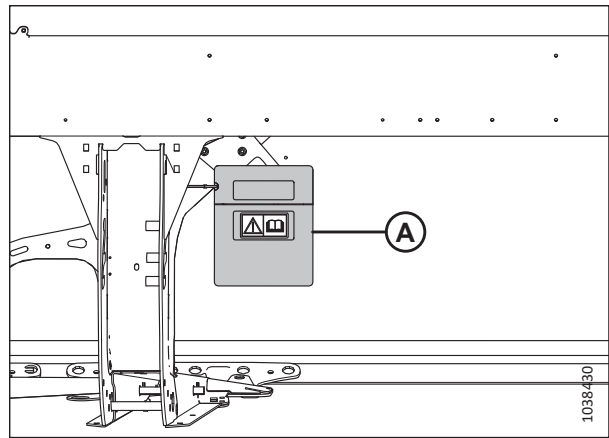

Figure 6.80: Manual Case – D230, D235

Chapter 7: Setting up Reel Position Sensors

The header has multiple sensors to inform the Operator where the reel is positioned.

7.1 Checking and Adjusting Reel Height Sensor

The orientation of the reel height sensor arm must be checked manually at the sensor. The output voltage range of the sensor can be checked either manually at the sensor or from the cab.

IMPORTANT:

Set the minimum reel height before adjusting the reel height sensor. For instructions, refer to and [6.9.1 Measuring Reel-to-Cutterbar Clearance, page 224](#).

NOTE:

For in-cab instructions, refer to the combine operator’s manual.

 **DANGER**

To prevent injury or death from the unexpected start-up of the machine, always stop the engine and remove the key from the ignition before leaving the operator’s seat for any reason.

 **DANGER**

Ensure that all bystanders have cleared the area.

1. On the right endsheet, locate reel height sensor (A). The sensor connects to the right reel arm.

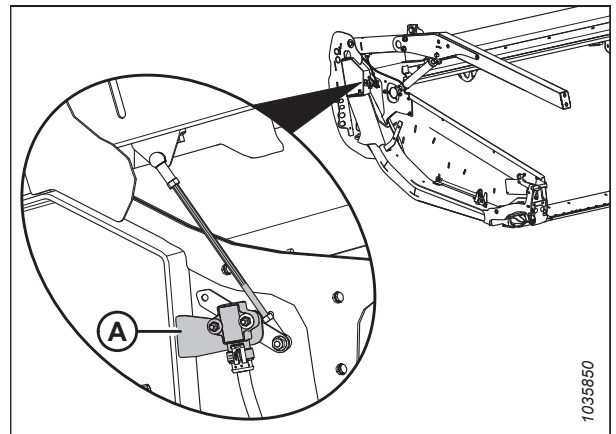

Figure 7.1: Reel Height Sensor Location

Checking and adjusting sensor output voltage when reel is lowered

2. Engage the parking brake.
3. Lower the reel fully.
4. Use the combine display or a voltmeter to measure the voltage range when the reel is lowered. Refer to [Table 7.1, page 259](#) for the recommended voltage ranges.

Table 7.1 Reel Height Sensor Voltage Limits

Combine Type	Recommended Voltage Range	
	Voltage with Reel Raised	Voltage with Reel Lowered
Case	0.7–1.1 V	3.9–4.3 V
Challenger®	3.9–4.3 V	0.7–1.1 V

SETTING UP REEL POSITION SENSORS

Table 7.1 Reel Height Sensor Voltage Limits (continued)

Combine Type	Recommended Voltage Range	
	Voltage with Reel Raised	Voltage with Reel Lowered
CLAAS	3.9–4.3 V	0.7–1.1 V
Gleaner®	3.9–4.3 V	0.7–1.1 V
IDEAL™	3.9–4.3 V	0.7–1.1 V
John Deere	3.9–4.3 V	0.7–1.1 V
Massey Ferguson®	3.9–4.3 V	0.7–1.1 V
New Holland	0.7–1.1 V	3.9–4.3 V
Rostselmash	0.7–1.1 V	3.9–4.3 V

5. Shut down the engine, and remove the key from the ignition.
6. Using a voltmeter, measure the voltage between the ground (pin 2 wire) and the signal (pin 3 wire) at reel height sensor (A).
7. Ensure that the voltage is within the recommended voltage range. If the voltage is not within the recommended range, loosen jam nuts (B) and (C), and adjust the rod length.
8. Tighten the jam nuts by hand until they are snug, then tighten the jam nuts by another quarter-turn.

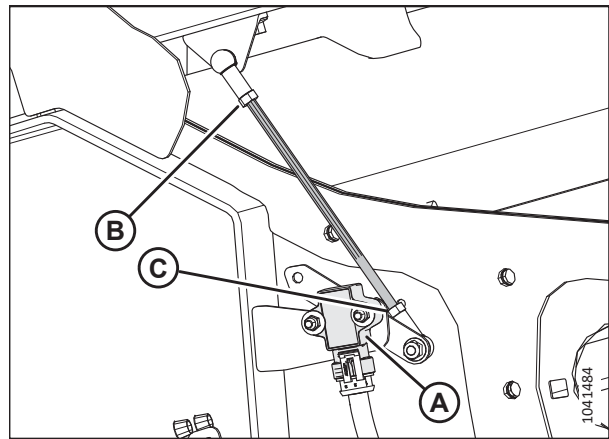

Figure 7.2: Reel Height Sensor – Right Reel Arm with Reel Down

Checking and adjusting sensor output voltage when reel is raised

9. Fully raise the reel.
10. Use the combine display or a voltmeter to measure the voltage range when the reel is raised. Refer to Table 7.1, page 259 for the recommended voltage ranges.
11. Shut down the engine, and remove the key from the ignition.

SETTING UP REEL POSITION SENSORS

12. Using a voltmeter, measure the voltage between the ground (pin 2 wire) and the signal (pin 3 wire) at reel height sensor (A).
13. If the voltage is not within the recommended range, loosen two M5 hex nuts (B) and rotate sensor (A) to achieve the recommended voltage range.
14. Tighten nuts (B) to 2.5 Nm (1.8 lbf·ft [22 lbf·in]).
15. Lower the reel fully.

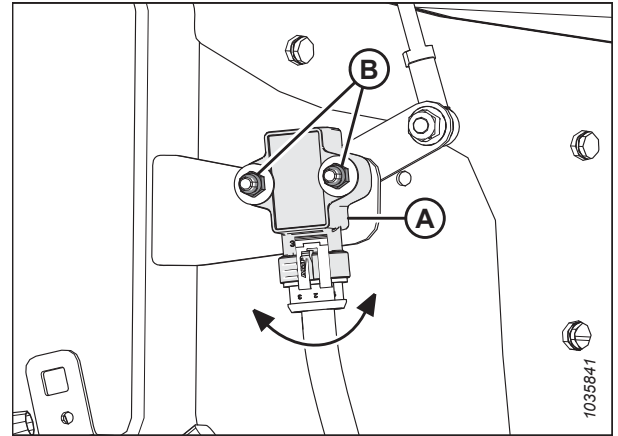

Figure 7.3: Reel Height Sensor – Right Reel Arm with Reel Up

7.2 Checking and Adjusting Reel Fore-Aft Position Sensor

The reel fore-aft position sensor indicates the position of the reel in the fore-aft plane. The sensor's mounting hardware and output voltage range must be checked.

DANGER

To prevent injury or death from the unexpected start-up of the machine, always stop the engine and remove the key from the ignition before leaving the operator's seat for any reason.

DANGER

Ensure that all bystanders have cleared the area.

Checking and adjusting sensor arm orientation

1. Park the combine on a level surface.
2. Shut down the engine, and remove the key from the ignition.

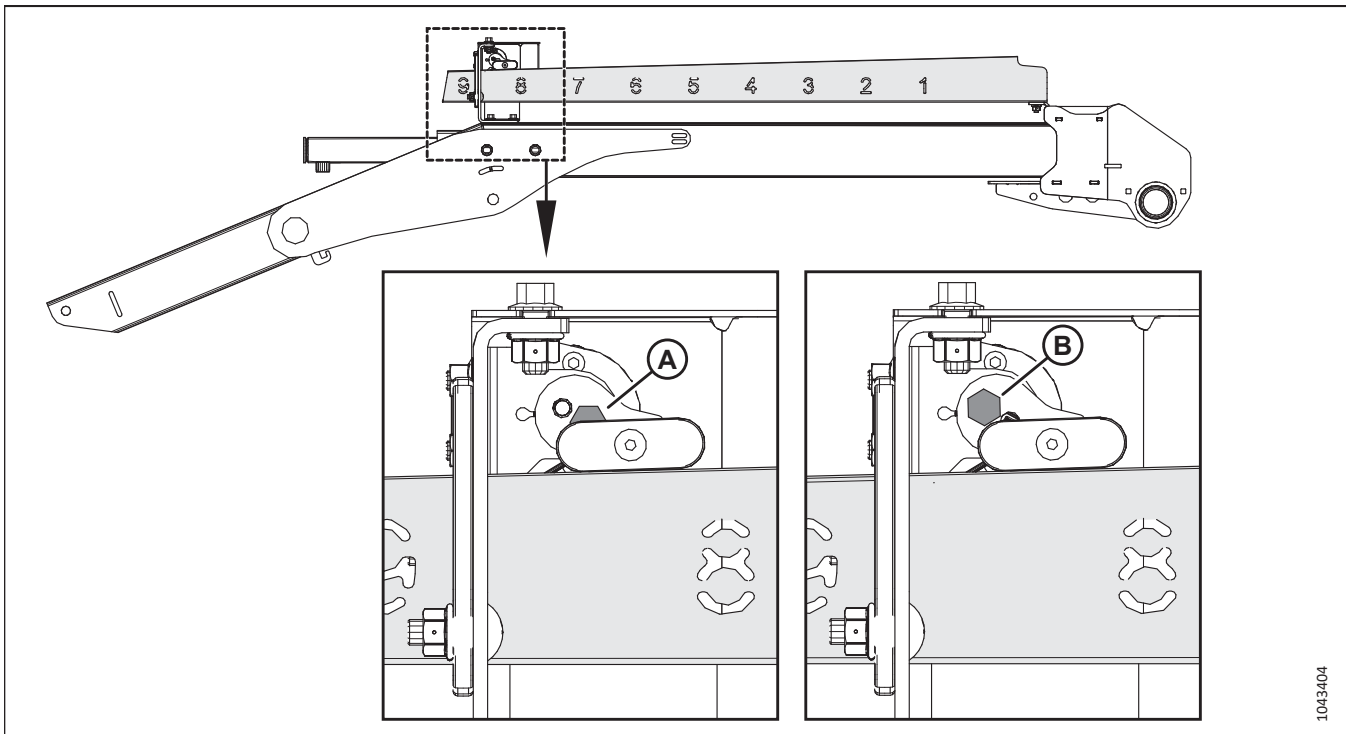

Figure 7.4: Sensor Arm Configurations

3. Check the installation location of the sensor mounting bolt:
 - Location (A) is used for Case, New Holland, and Rostselmash
 - Location (B) is used for Challenger®, CLAAS, Gleaner®, IDEAL™, Massey Ferguson®, and John Deere

If the bolt is in the incorrect location, reinstall it in the correct location, and tighten it to 6 Nm (4 lbf-ft [53 lbf-in]).

SETTING UP REEL POSITION SENSORS

Checking and adjusting sensor output voltage

4. Engage the parking brake.

IMPORTANT:

To measure the output voltage of the fore-aft sensor, the engine needs to be running and supplying power to the sensor.

5. Adjust the reel to the fully forward position. Ensure that dimension (A) (from the sensor bracket to the end of the indicator) is 62–72 mm (2 3/8–2 3/4 in.).

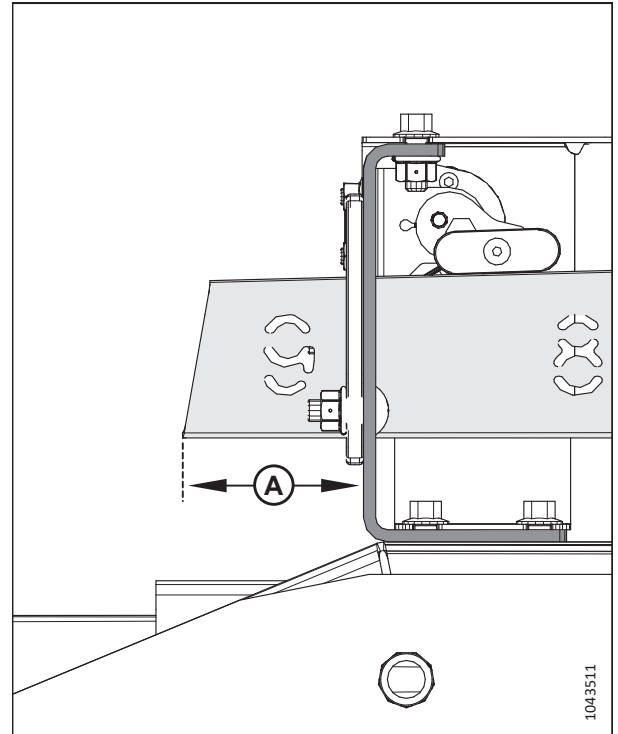

Figure 7.5: Fore-Aft Bracket

SETTING UP REEL POSITION SENSORS

6. Use the combine display or a voltmeter (if measuring the sensor manually) to measure the voltage range. If you are using a voltmeter, check the voltage at sensor (A) between pin 2 (ground) and pin 3 (signal).
 - For Case, New Holland, and Rostselmash combines, the voltage range should be 0.7–1.1 V.
 - For Challenger®, CLAAS, Gleaner®, IDEAL®, John Deere, and Massey Ferguson® combines, the voltage range should be 3.9–4.3 V.
7. Shut down the engine, and remove the key from the ignition.
8. If adjustment is required, loosen nuts (B) and move bracket (C) vertically until the voltage is in the correct range.
9. Once sensor adjustment is complete, torque the nuts to 8 Nm (6 lbf-ft [71 lbf-in]).

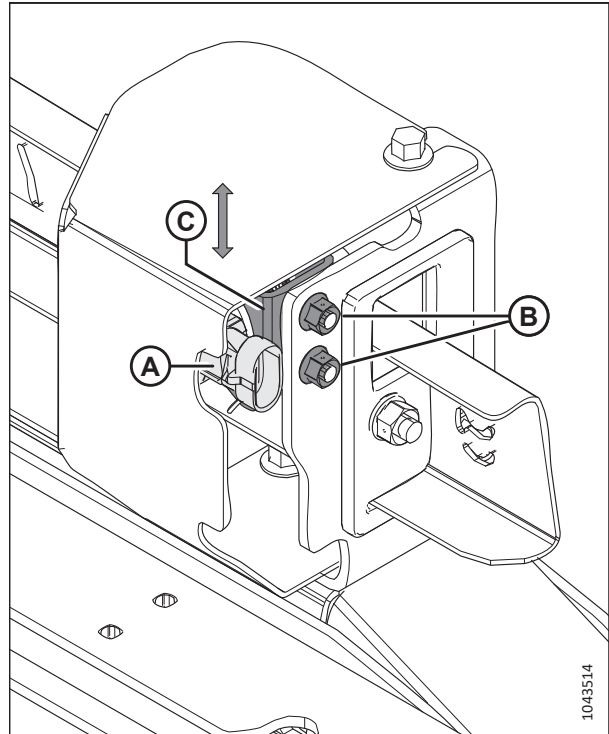

Figure 7.6: Fore-Aft Sensor

NOTE:

Shoulder bolt (A) ensures that the bolt will remain free-spinning.

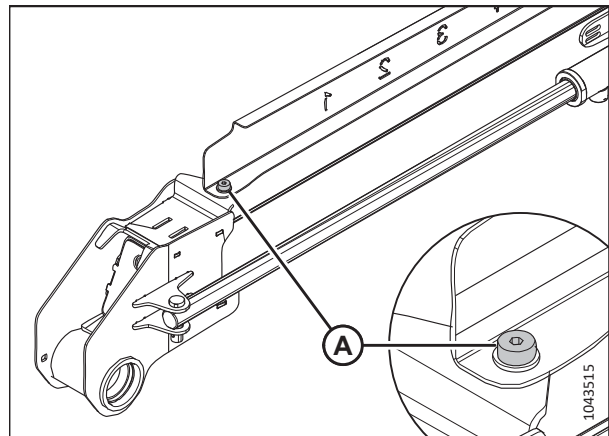

Figure 7.7: Indicator Bolt

Chapter 8: Setting Up Auto Header Height Control System

The auto header control system will need to be configured specifically for the customer's combine.

8.1 Auto Header Height Control System

MacDon's auto header height control (AHHC) system works in conjunction with the AHHC option available on certain combine models. Once the header has been assembled and attached to the combine, the AHHC system will need to be configured to work with the combine.

Two Hall effect sensors (A) are installed on the float setting indicators on the float module. These sensors send signals to the combine, which allow the combine to maintain the header at a consistent cutting height and the optimum float setting as the header follows the contours of the ground.

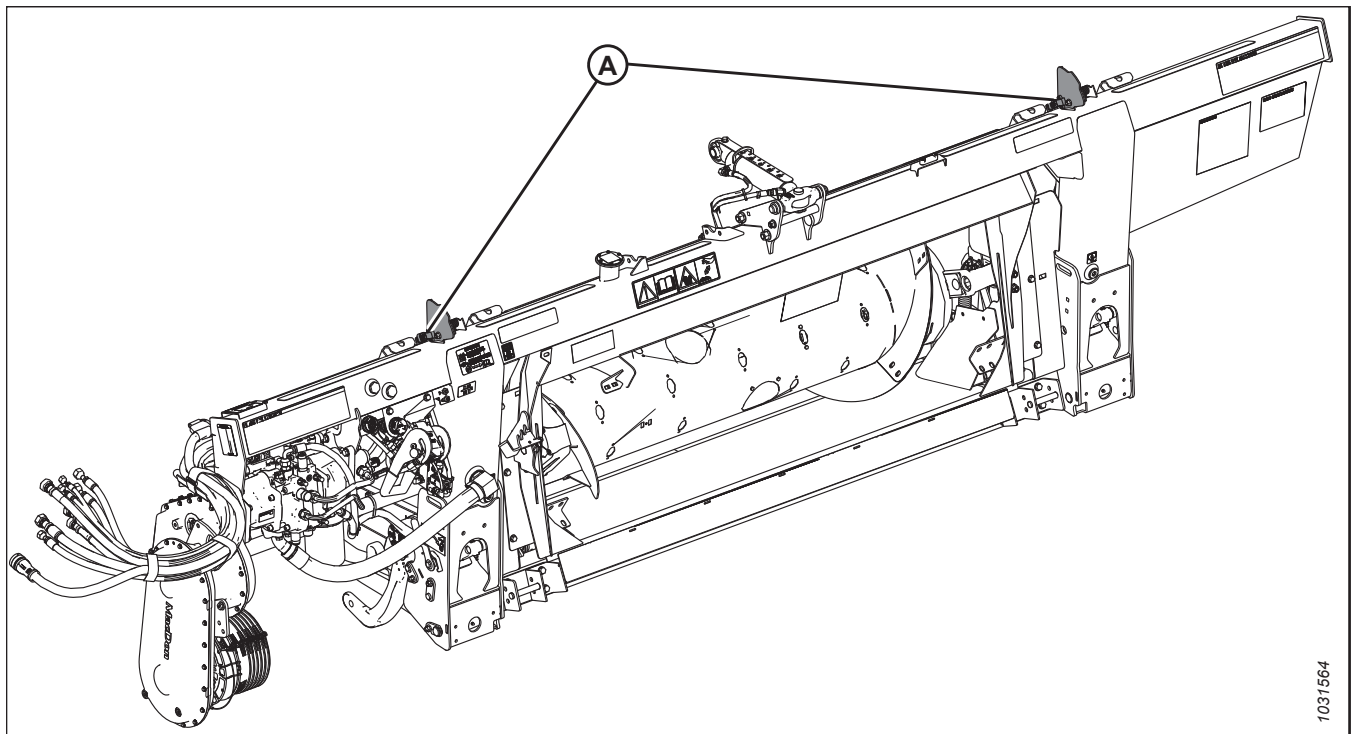

Figure 8.1: FM200 Float Module

Complete the following tasks before using the AHHC system:

1. Prepare the combine to use the AHHC feature (applies only to some combine models—refer to the instructions for your combine).
2. Calibrate the sensors used by the AHHC system so that the combine can correctly interpret data from the Hall effect sensors on the float module. For more information, refer to the combine operator's manual.

To configure the AHHC system for a particular combine model, refer to the relevant procedure:

- [8.1.5 Case IH 130 and 140 Series Mid-Range Combines, page 274](#)
- [8.1.6 Case IH 120, 230, 240, and 250 Series Combines, page 284](#)
- [8.1.7 Challenger® and Massey Ferguson® 6 and 7 Series Combines, page 306](#)
- [8.1.8 CLAAS Lexion 500 Series Combines, page 315](#)
- [8.1.9 CLAAS Lexion 600 and 700 Series Combines, page 326](#)
- [8.1.10 CLAAS Lexion 5/6/7/8000 Series and TRION Series Combines, page 338](#)

SETTING UP AUTO HEADER HEIGHT CONTROL SYSTEM

- 8.1.11 Gleaner® R65, R66, R75, R76, and S Series Combines, page 350
- 8.1.12 Gleaner® S9 Series Combines, page 362
- 8.1.13 IDEAL™ Series Combines, page 379
- 8.1.15 John Deere 70 Series Combines, page 403
- 8.1.16 John Deere S and T Series Combines, page 410
- 8.1.17 John Deere S7 Series Combines, page 430
- 8.1.18 John Deere X9 Series Combines, page 444
- 8.1.19 New Holland CR and CX Series Combines – 2014 and Earlier, page 458
- 8.1.20 New Holland Combines – CR Series (2015 and Later) and CH, page 469
- 8.1.21 Rostselmash Combines – RSM 161, T500, and TORUM 785, page 491

8.1.1 Auto Header Height Control Sensor Operation

The position sensors supplied with the auto header height control (AHHC) system communicate data about the header's height to the combine's computer.

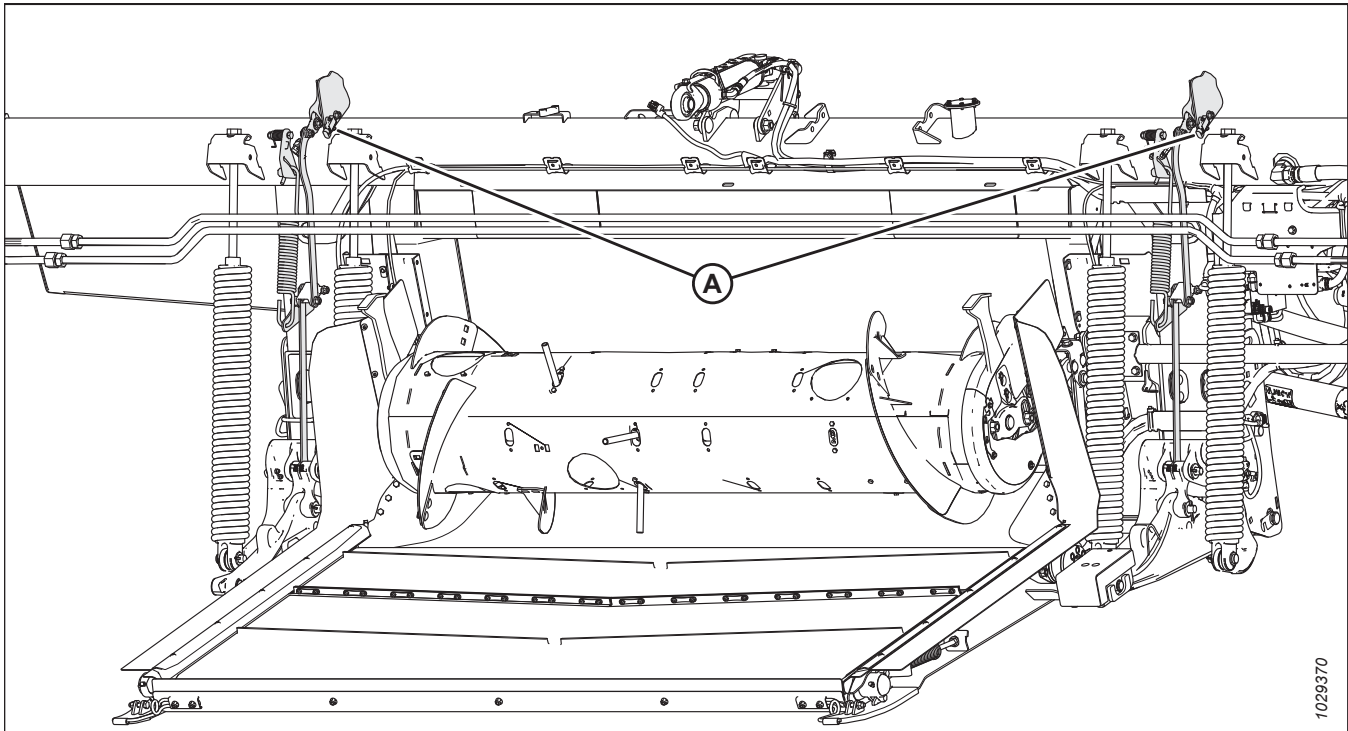

Figure 8.2: Height Control Sensor Locations on Float Module

Auto header height control sensor overview

Two Hall effect sensors are installed on float indicator needles (A). As the header rises and falls, the sensors communicate the header's height to the combine's computer. The combine's computer will, in response, raise or lower the feeder house so that the header can maintain a consistent cutting height.

The normal operating signal voltages for the sensors fall between 0.7 VDC and 4.3 VDC. An increase in sensor voltage correlates to an increase in header height, while a decrease in sensor voltage correlates to a decrease in header height. Any sensor error results in a 0 V signal, which indicates either a faulty sensor or insufficient voltage supply.

SETTING UP AUTO HEADER HEIGHT CONTROL SYSTEM

Auto header height control sensor voltage ranges

The voltage reported by the sensors occurs in a range of at least 2.5 V (Range [A]) and at most 4.0 V (Range [B]). The ideal voltage range for the sensors is 0.7–4.3 V (Range C), a total range of 3.6 V. If the voltage is too close to low end (D) of the voltage range, calibrating the AHHC system will be difficult. A properly set sensor will have sufficient clearance on both ends of the voltage range.

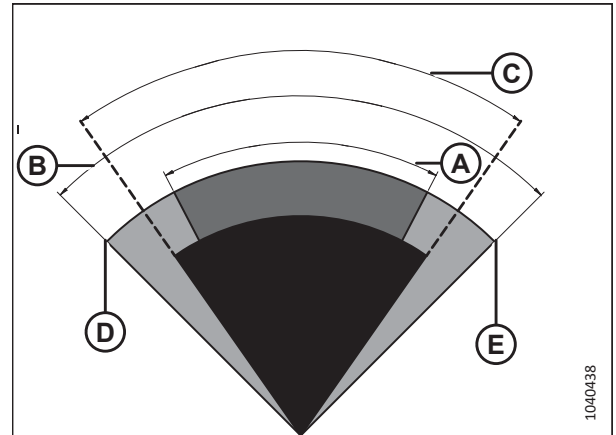

Figure 8.3: Optimal Sensor Voltage Range

A - Minimum Voltage Range – 2.5 V B - Maximum Voltage Range – 4.0 V
C - Ideal Voltage Range – 3.6 V D - Minimum Voltage – 0.5 V
E - Maximum Voltage – 4.5 V

A sensor that is configured so that the voltage range (for example, voltage range [C]) is too close to the sensor's low voltage limit (D) or high voltage limit (E) will have difficulty staying within the sensor's operating range of ideal operating range (A) of 0.7–4.3 V. If the sensor reports values that are above maximum voltage (E) or minimum voltage (D), the AHHC system will stop functioning correctly.

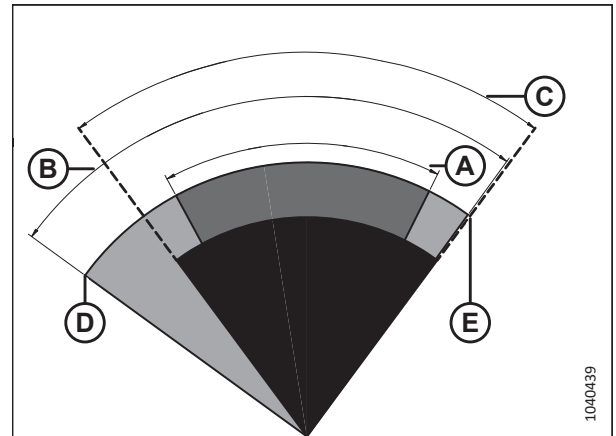

Figure 8.4: Sensor Range Set too Close to Voltage Limit

A - Minimum Voltage Range – 2.5 V B - Maximum Voltage Range – 4.0 V
C - Configured Voltage Range D - Minimum Voltage – 0.5 V
E - Maximum Voltage – 4.5 V

SETTING UP AUTO HEADER HEIGHT CONTROL SYSTEM

A sensor configured to have a voltage range that is less than 2.5 V (for example, range [C]) will have difficulty staying within the ideal range of 3.6 V. The combine will seek to keep the sensor within the narrow set range, resulting in the combine continually raising and lowering the header to search for the appropriate header height.

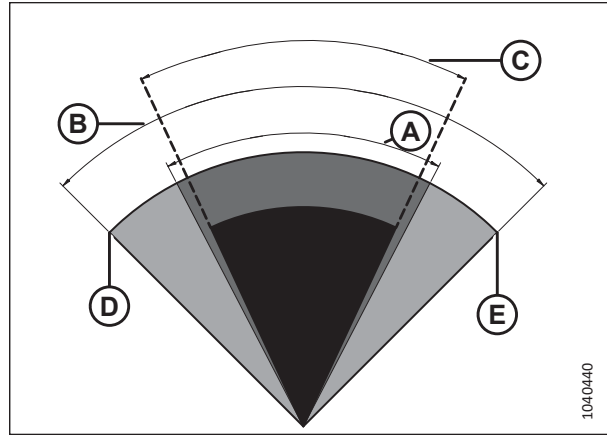

Figure 8.5: Sensor Range too Narrow

A - Minimum Voltage Range – 2.5 V B - Maximum Voltage Range – 4.0 V
 C - Configured Voltage Range D - Minimum Voltage – 0.5 V
 E - Maximum Voltage – 4.5 V

8.1.2 Recommended Sensor Output Voltages for Combines

The auto header height control (AHHC) sensor output must be within a specific voltage range for each combine, or the AHHC feature will not work properly. The recommended lower and upper voltage values for best AHHC operation are provided.

Table 8.1 Combine Voltage Limits

Combine	Lower Voltage Limit (V)	Upper Voltage Limit (V)	Minimum Range (V)
Case IH	0.7	4.3	2.5
Challenger®	0.7	4.3	2.5
CLAAS	0.7	4.3	2.5
IDEAL™ Series	0.7	4.3	2.5
Gleaner®	0.7	4.3	2.5
John Deere	0.7	4.3	2.5
Massey Ferguson®	0.7	4.3	2.5
New Holland - 5 V system	0.7	4.3	2.5
New Holland - 10 V system	2.8	7.2	4.1–4.4
Rostselmash	0.7	4.3	2.5

8.1.3 Manually Checking Voltage Limits

For the auto header height (AHC) system to function correctly, the voltages reported to the combine by the header height sensors must occur within the specified range.

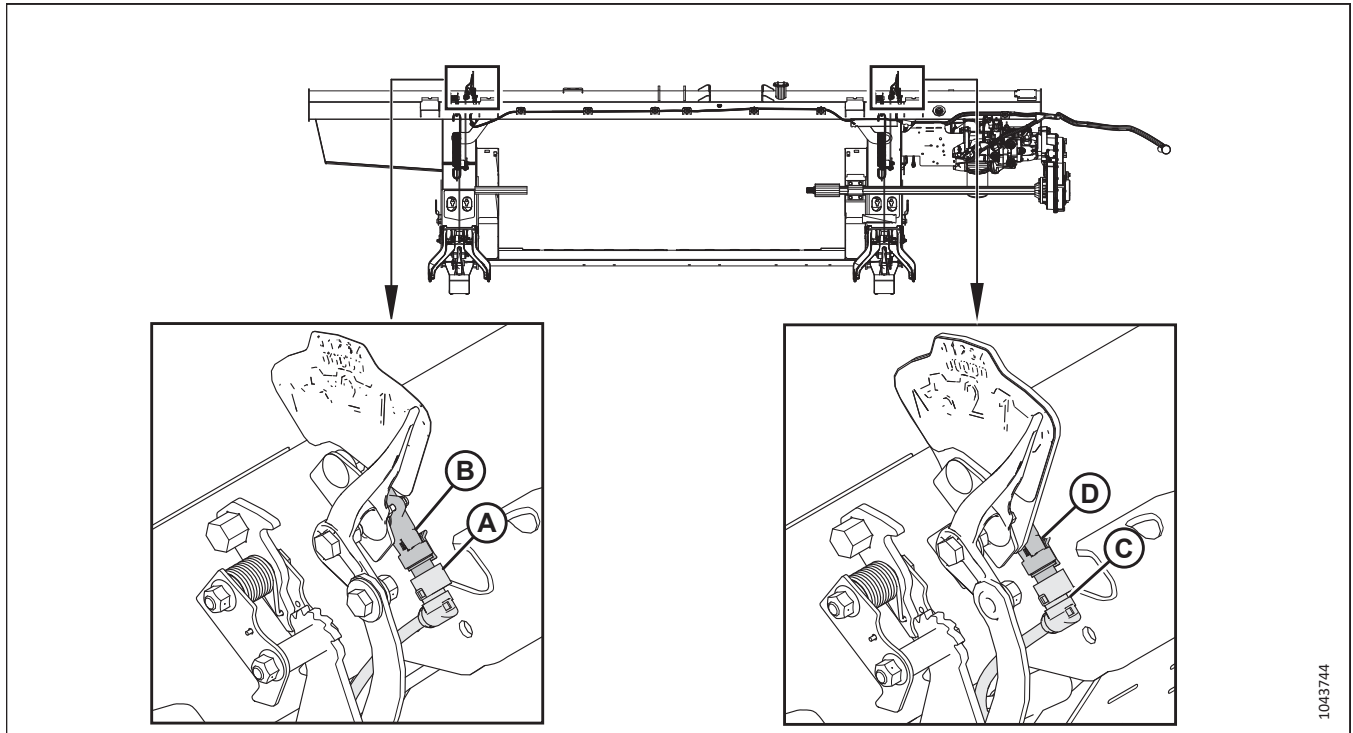

Figure 8.6: Auto Header Height Control Sensors

NOTE:

Both auto header height control (AHC) sensors will need to be checked that they are receiving power from the combine, and are sending high and low voltages within acceptable ranges as specified in [8.1.2 Recommended Sensor Output Voltages for Combines, page 268](#). It does not matter whether you check the left or the right sensor first.

- Connector P539 (A) connects to right AHC sensor (B)
- Connector P537 (C) connects to left AHC sensor (D)

NOTE:

One of the following plugs will be installed in connector P600 (A). This plug determines how the voltage signal is sent to the combine:

- Averaging Plug (MD #328560 [B7489]): This plug sends the average of both sensors to the combine.
- Lateral Tilt Plug (MD #328318 [B7196]): This plug sends separate voltage signals from both sensors to the combine, with averaged center signals.
- Pass-Through Plug (MD #323698 [B7490]): Each sensor sends a voltage signal directly to the combine. There are no averaged center signals.

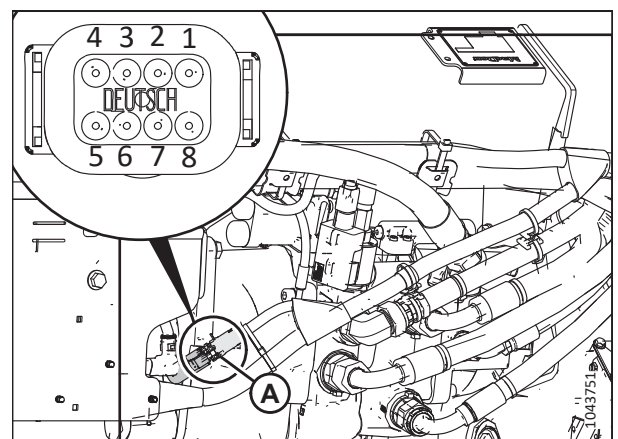

Figure 8.7: Connector

NOTE:

On some combine models, you can see the voltage from the combine cab.

SETTING UP AUTO HEADER HEIGHT CONTROL SYSTEM

DANGER

To prevent injury or death from the unexpected start-up of the machine, always stop the engine and remove the key from the ignition before leaving the operator's seat for any reason.

DANGER

Ensure that all bystanders have cleared the area.

Checking for power from combine, and for sensor upper voltage limit

1. Park the combine on a level surface.
2. Extend the guard angle until header angle indicator (A) is at position E on the center-link.
3. Position the header so that the cutterbar is 254–356 mm (10–14 in.) off the ground.
4. Shut down the engine, and remove the key from the ignition.

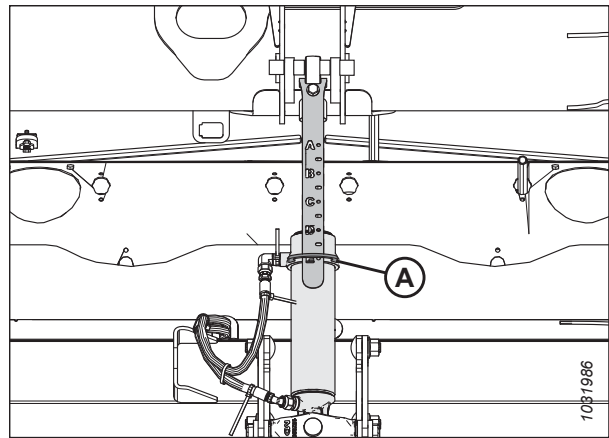

Figure 8.8: Center-Link

CAUTION

To prevent cuts, pinches, and other bodily harm to the person checking the down stops, ensure that nobody is manually lifting, bouncing, or moving the header in any way while the down stop washer is being touched and checked for movement.

5. Ensure that the float lock linkage is on the down stops (washer [A] cannot move) at both locations.

NOTE:

If the header is **NOT** on the down stops, the voltage may go out of range during operation and cause the AHHC system to malfunction. To fix the problem, make the header heavier by decreasing the float. For instructions, refer to [6.10 Checking and Adjusting Header Float, page 229](#).

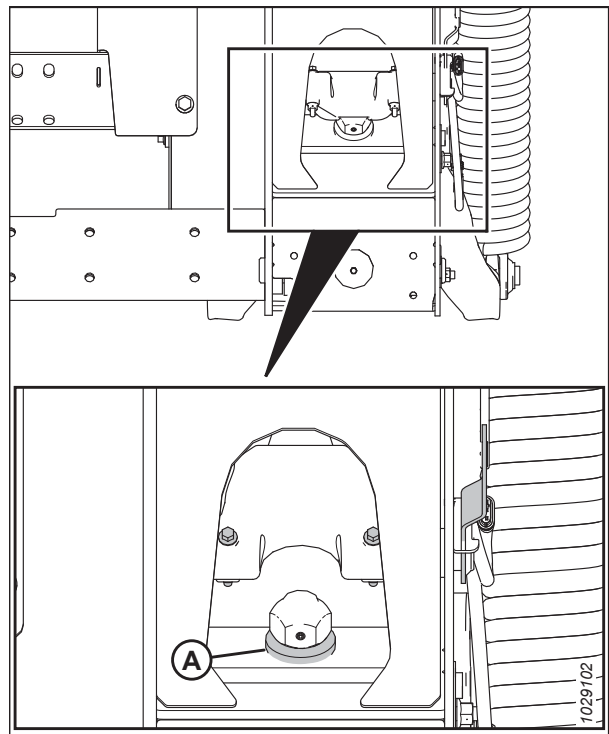

Figure 8.9: Down Stop Washer

SETTING UP AUTO HEADER HEIGHT CONTROL SYSTEM

- If the pointer is not on zero, loosen bolt (A) and slide float indicator plate (B) until pointer (C) is on **0** (D). Tighten the nut on bolt (A).

NOTE:

Use zero dot (E) above the decal to correctly set the indicator needle.

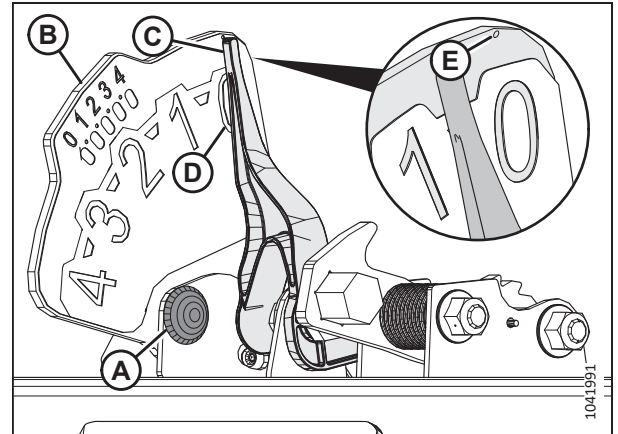

Figure 8.10: Float Indicator

- Disconnect connectors P539 and P537 from the AHHC sensors.
- Using a digital multimeter, check connectors P537 and P539 for power from the combine. The multimeter should read 5 V at pin 1.
 - P537:** Pin 1 - FM2215B – left sensor power
 - P537:** Pin 2 - FM2515B – left sensor ground
 - P539:** Pin 1 - FM2215D – right sensor power
 - P539:** Pin 2 - FM2515D – right sensor ground

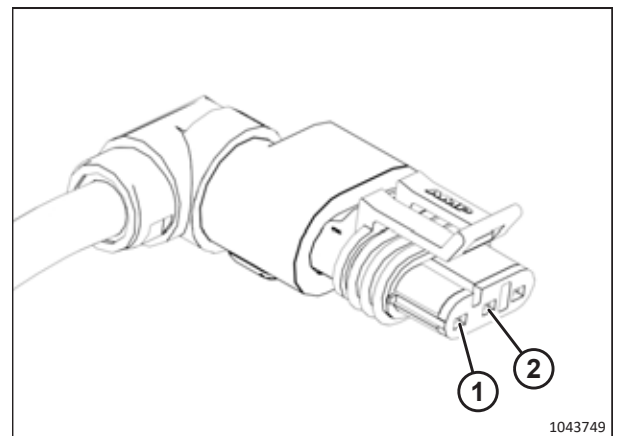

Figure 8.11: Connector P537 or P539

SETTING UP AUTO HEADER HEIGHT CONTROL SYSTEM

9. Reconnect connectors P539 and P537 to the sensors.
10. Insert the key into the ignition and turn it to the RUN position.
11. Unlock tab (A) and remove backshell (B) from connectors P539 and P537.

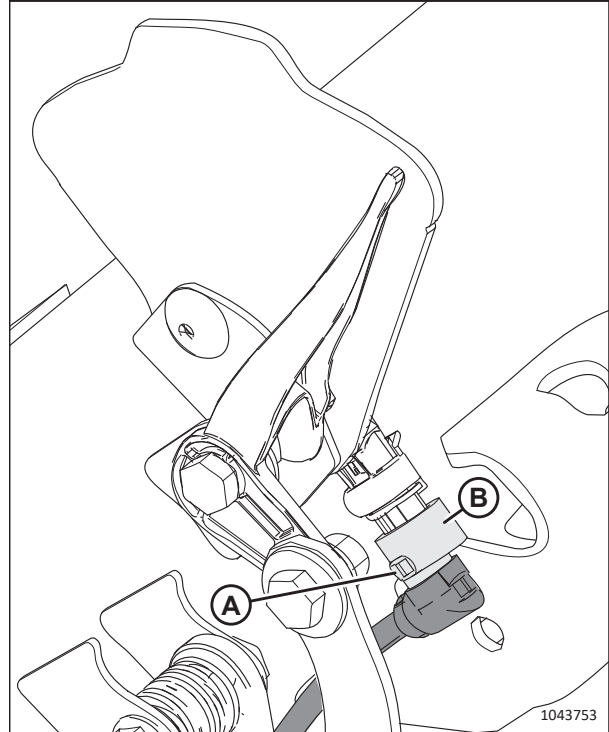

Figure 8.12: Auto Header Height Control Sensor

12. Locate wire (A) connected to pin 3:
 - **P537:** Pin 3 - FM3326A – left sensor signal
 - **P539:** Pin 3 - FM3328A – right sensor signal
13. Back-probe pin 3 and check that the voltage is in the upper range as specified in [8.1.2 Recommended Sensor Output Voltages for Combines, page 268](#).

NOTE:

With the float lock linkage on the down stops, the upper voltage reading must be the same on both (left and right) sensors.

14. If you need to adjust the voltage, then loosen nuts (B), reposition sensor (C) in the indicator plate, then tighten nuts (B) to 3 Nm (2.2 lbf-ft [22 lbf-in]).

NOTE:

While tightening the nuts, make sure that sensor (C) does **NOT** move in the indicator plate.

15. Turn the key to the OFF position, and remove the key from the ignition.

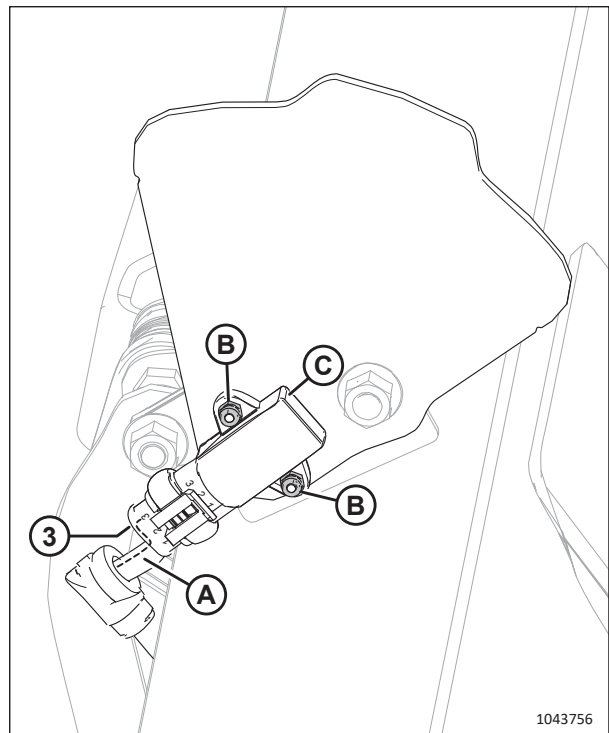

Figure 8.13: Auto Header Height Control Sensor

SETTING UP AUTO HEADER HEIGHT CONTROL SYSTEM

Checking sensor lower voltage limit

16. Lower the header fully.
17. Shut down the engine.
18. Float indicator pointer (A) should be at 4 (B).
19. Turn the ignition key it to the RUN position.
20. Back-probe pin 3 and check that the voltage is in the lower range as specified in [8.1.2 Recommended Sensor Output Voltages for Combines, page 268](#).
 - **P537:** Pin 3 - FM3326A – left sensor signal
 - **P539:** Pin 3 - FM3328A – right sensor signal
21. If you need to adjust the voltage, refer to Step [14, page 272](#) for instructions.
22. Turn the key to the OFF position, and remove the key from the ignition.
23. Reinstall the backshell on connectors P539 and P537.

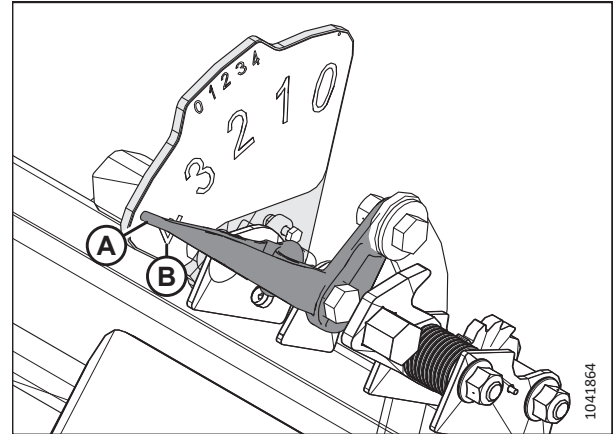

Figure 8.14: Left Float Indicator – View from Rear

8.1.4 10 Volt Adapter – New Holland Combines Only

New Holland combines equipped with a 10 V system require a 10 V adapter in order to calibrate the auto header height control (AHHC) system.

If a 10 V New Holland combine does not have adapter (A) installed, the AHHC output will always read 0 V, regardless of the sensor's position.

For instructions on checking the sensor voltages, refer to [Checking Voltage Range from Combine Cab – New Holland CR and CX Series, page 458](#) or [8.1.3 Manually Checking Voltage Limits, page 269](#).

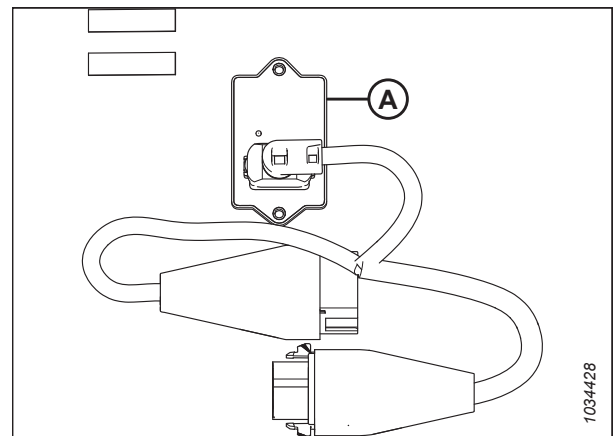

Figure 8.15: 10 V Adapter (B7241)

8.1.5 Case IH 130 and 140 Series Mid-Range Combines

To make the auto header height control (AHHC) system compatible for Case IH 130 and 140 Series mid-range combines, you must configure the reel speed settings, set up the AHHC controls, and calibrate the AHHC system to ensure that it is working correctly.

Checking Voltage Range from Combine Cab – Case IH 5130, 5140, 6130, 6140, 7130, and 7140

The auto header height control sensor needs to operate within a specific voltage range in order to work properly.

NOTE:

Changes may have been made to the combine controls or the display since this document was published. For the most up-to-date information, refer to the combine operator's manual.

⚠ DANGER

To prevent bodily injury or death from the unexpected start-up of the machine, always stop the engine and remove the key from the ignition before making adjustments to the machine.

⚠ DANGER

Ensure that all bystanders have cleared the area.

1. Position the header so that the cutterbar is 254–356 mm (10–14 in.) off the ground.
2. Shut down the engine, and remove the key from the ignition.
3. Unlock the header float. For instructions, refer to the header operator's manual.

⚠ CAUTION

To prevent cuts, pinches, and other bodily harm to the person checking the down stops, ensure that nobody is manually lifting, bouncing, or moving the header in any way while the down stop washer is being touched and checked for movement.

4. Ensure that the float lock linkage is on the down stops (washer [A] cannot move) at both locations.

NOTE:

If the header is **NOT** on the down stops, the voltage may go out of range during operation and cause the AHHC system to malfunction. To fix the problem, make the header heavier by decreasing the float. For instructions, refer to [6.10 Checking and Adjusting Header Float, page 229](#).

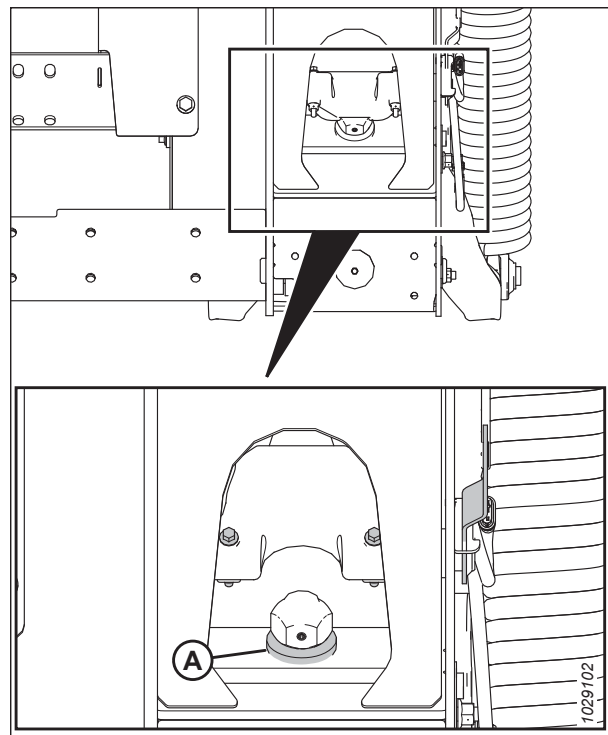

Figure 8.16: Down Stop Washer

SETTING UP AUTO HEADER HEIGHT CONTROL SYSTEM

- If the pointer is not on zero, loosen bolt (A) and slide float indicator plate (B) until pointer (C) is on 0 (D). Tighten the nut on bolt (A).

NOTE:

Use zero dot (E) above the decal to correctly set the indicator needle.

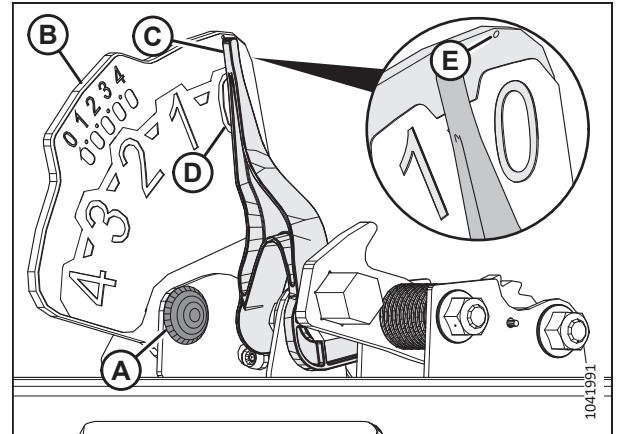

Figure 8.17: Float Indicator

- On the main page of the combine display, select DIAGNOSTICS (A). The DIAGNOSTICS page appears.

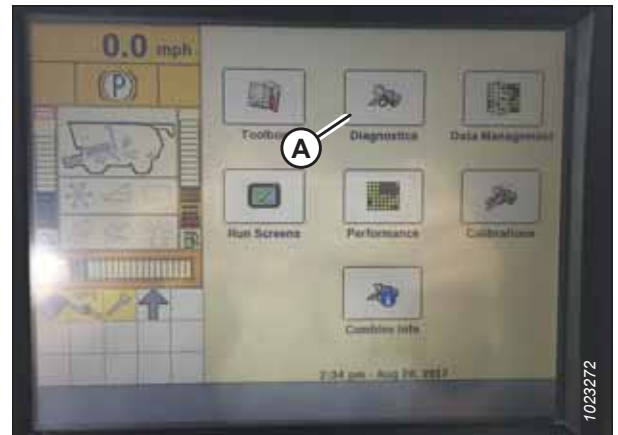

Figure 8.18: Case IH Combine Display

- Select SETTINGS (A). The SETTINGS page appears.
- From the GROUP menu, select HEADER (B).

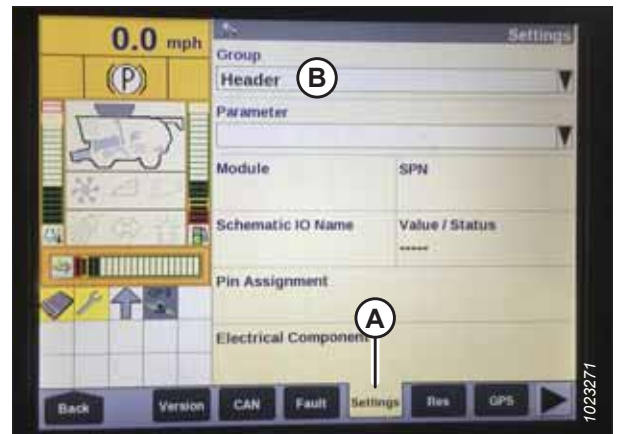

Figure 8.19: Case IH Combine Display

SETTING UP AUTO HEADER HEIGHT CONTROL SYSTEM

- From the PARAMETER menu, select LEFT HEIGHT/TILT SENSOR (A).



Figure 8.20: Case IH Combine Display

- The SETTINGS page updates to display the voltage in VALUE/STATUS field (A). Lower the feeder house fully, and then raise it 254–356 mm (10–14 in.) off the ground to view the full range of voltage readings.
- If the sensor voltage is not within the lower and upper limits, or if the range between the lower and upper limits is insufficient, refer to [8.1.3 Manually Checking Voltage Limits, page 269](#).



Figure 8.21: Case IH Combine Display

Header Settings Quick Reference – Case IH 130 and 140 Series

The recommended auto header height control (AHC) settings for a D2 Series Draper Header operating with a Case IH 130 and 140 Series combine are provided.

NOTE:

Changes may have been made to the combine controls or the display since this document was published. For the most up-to-date information, refer to the combine operator’s manual.

Table 8.2 Header Settings – Case IH 130 and 140 Series

Setup Parameter	Suggested Setting	
Cutting type	Platform	
Header pressure float	Not installed	
HHC height sensitivity ²¹	Two-sensor system	250
	One-sensor system	180
HHC tilt sensitivity	150	

21. If hunting occurs during operation, decrease the HHC HEIGHT SENSITIVITY setting by 20 points at a time until hunting no longer occurs.

SETTING UP AUTO HEADER HEIGHT CONTROL SYSTEM

Table 8.2 Header Settings – Case IH 130 and 140 Series (continued)

Setup Parameter	Suggested Setting	
Reel drive type	Standard 19-tooth drive sprocket	4
	Optional high-torque 14-tooth drive sprocket	5
	Optional high-torque 10-tooth drive sprocket	6
Reel height sensor	Yes	
Autotilt	Two-sensor system	YES
	One-sensor system	NO

Setting up Header on Combine Display – Case IH 5130, 5140, 6130, 6140, 7130, and 7140

To set up the header to work with the combine, you will need to access the HEADER SETUP page on the combine display.

NOTE:

Changes may have been made to the combine controls or the display since this document was published. For the most up-to-date information, refer to the combine operator's manual.

1. On the main page of the combine display, select TOOLBOX icon (A).

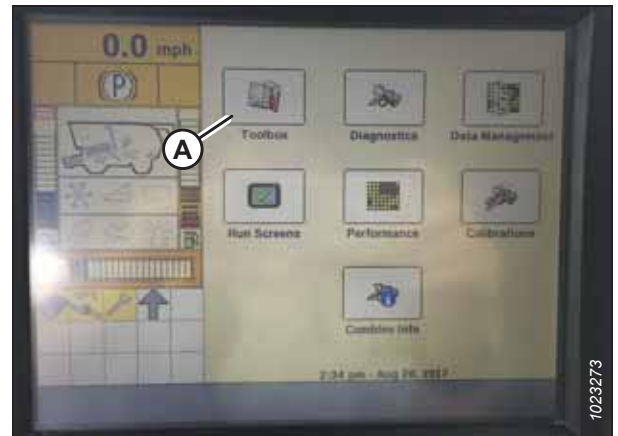

Figure 8.22: Case IH Combine Display

2. Select HEAD 1 tab (A). The HEADER SETUP page appears.

NOTE:

To locate the HEAD 1 tab, you may need to use side arrows (C).

3. From CUTTING TYPE menu (B), select PLATFORM.



Figure 8.23: Case IH Combine Display

SETTING UP AUTO HEADER HEIGHT CONTROL SYSTEM

4. Select HEAD 2 tab (A). The HEADER SETUP 2 page appears.
5. From HEADER PRESSURE FLOAT menu (B), select NOT INSTALLED.
6. From DRAPER GRAIN HEADER STYLE menu (C), select RIGID 2000 SERIES.

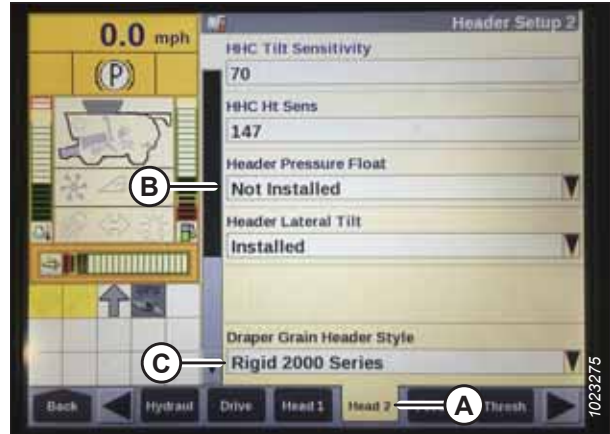

Figure 8.24: Case IH Combine Display

7. Locate HHC HEIGHT SENSITIVITY field (A). Enter the following settings:
 - **Two-sensor system:** Set HHC HEIGHT SENSITIVITY to 250.
 - **Single-sensor system:** Set HHC HEIGHT SENSITIVITY to 180.

NOTE:

If the combine continually raises and lowers the header during operation (a behavior termed “hunting”), decrease the HHC HEIGHT SENSITIVITY setting by 20 points at a time until hunting no longer occurs.

8. Set HHC TILT SENSITIVITY (B) to 150. Increase or decrease this value as desired.
9. From REEL DRIVE TYPE menu (A), select one of the following:
 - If the combine is equipped with a standard 19-tooth drive sprocket, select 4.
 - If the combine is equipped with an optional high-torque 14-tooth drive sprocket, select 5.
 - If the combine is equipped with an optional high-torque 10-tooth drive sprocket, select 6.



Figure 8.25: Case IH Combine Display

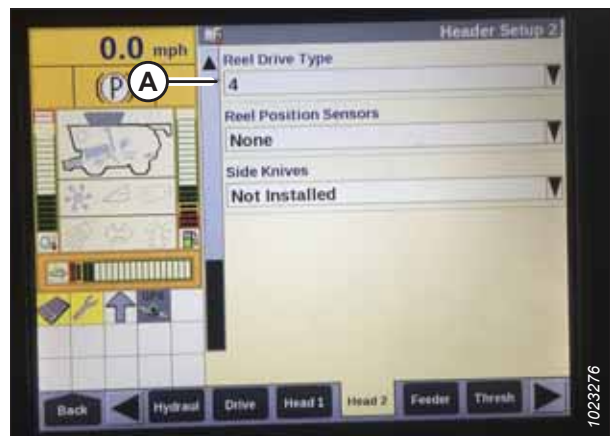

Figure 8.26: Case IH Combine Display

SETTING UP AUTO HEADER HEIGHT CONTROL SYSTEM

10. From REEL HEIGHT SENSOR menu (A), select YES.



Figure 8.27: Case IH Combine Display

11. Locate AUTOTILT field (A).

- **Two-sensor system:** Select YES.
- **Single-sensor system:** Select NO.



Figure 8.28: Case IH Combine Display

Calibrating Auto Header Height Control – Case IH 5130, 5140, 6130, 6140, 7130, and 7140 Combines with Software Version below 28.00

The auto header height control (AHC) sensor output must be calibrated for each combine.

! DANGER

To prevent bodily injury or death from the unexpected start-up of the machine, always stop the engine and remove the key from the ignition before making adjustments to the machine.

! DANGER

Ensure that all bystanders have cleared the area.

NOTE:

Changes may have been made to the combine controls or the display since this document was published. For the most up-to-date information, refer to the combine operator's manual.

NOTE:

If the header float is set too light, it can prevent the calibration of the AHC. In order to prevent the header from separating from the float module, it may be necessary to change the float to a heavier setting during calibration.

1. Park the combine on a level surface.

SETTING UP AUTO HEADER HEIGHT CONTROL SYSTEM

2. Ensure that the header is level with the ground. If adjustment is required, refer to [10.5 Leveling Header, page 526](#).

NOTE:

Spirit level (A) is located on top of the float module frame. The header is level if the bubble is in the center of the spirit level.

3. Ensure that the center-link is set to **D**.

NOTE:

When calibration is complete, adjust the center-link back to the desired header angle. For instructions, refer to the header operator's manual.

4. Adjust the reel fore-aft position so that the indicator is at position **6**.
5. Position the header so that the cutterbar is 254–356 mm (10–14 in.) off the ground.
6. Shut down the engine, and remove the key from the ignition.

CAUTION

To prevent cuts, pinches, and other bodily harm to the person checking the down stops, ensure that nobody is manually lifting, bouncing, or moving the header in any way while the down stop washer is being touched and checked for movement.

7. Ensure that the float lock linkage is on the down stops (washer [A] cannot move) at both locations.

NOTE:

If the header is **NOT** on the down stops, the voltage may go out of range during operation and cause the AHHC system to malfunction. To fix the problem, make the header heavier by decreasing the float. For instructions, refer to [6.10 Checking and Adjusting Header Float, page 229](#).

8. Unlock the header float. For instructions, refer to the header operator's manual.

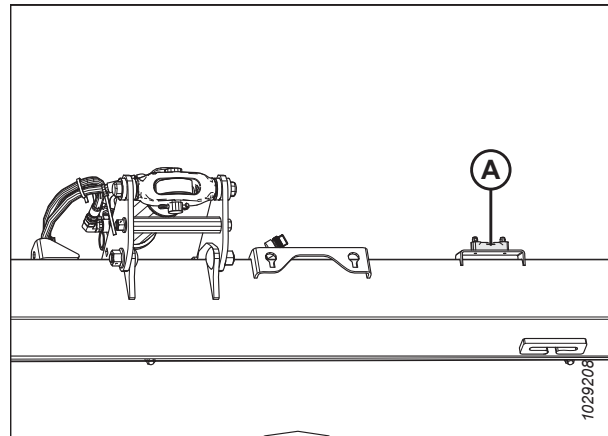

Figure 8.29: Spirit Level

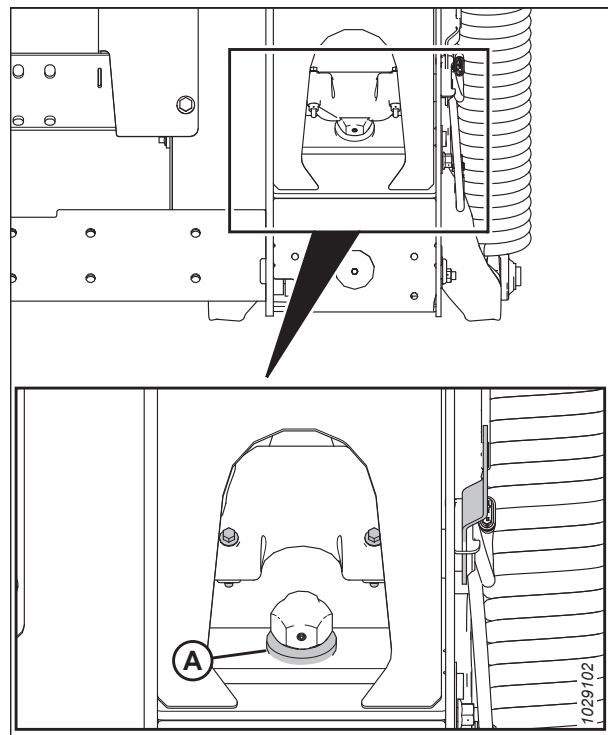

Figure 8.30: Down Stop Washer

SETTING UP AUTO HEADER HEIGHT CONTROL SYSTEM

9. Select the DIAGNOSTICS button from the Home Screen, then select VERSION tab (A).
10. Ensure that the software version is **lower than 28.00**. If the software version is higher than 28.00, refer to [Calibrating Auto Header Height Control – Case IH Combines with Version 28.00 or Higher Software, page 292](#).



Figure 8.31: Case IH Combine Display

11. Locate the HEADER CONTROL switch on the right console. Set the HEADER CONTROL to HT (AHHC mode).
12. Hold the DOWN button for 10 seconds to lower the combine feeder house (the feeder house should stop moving).
13. Hold the RAISE button until the feeder house travels all the way up. It will stop 0.6 m (2 ft.) above the ground for 5 seconds, then resume traveling upward. This indicates that the calibration procedure was successful.
14. If the float was changed to a heavier setting to complete calibration, adjust the header to the recommended float weight.

Setting Preset Cutting Height – Case IH 5130, 5140, 6130, 6140, 7130, and 7140

The header's cutting and raised positions can be configured as presets on the combine's control console.

NOTE:

Changes may have been made to the combine controls or the display since this document was published. For the most up-to-date information, refer to the combine operator's manual.

DANGER

Ensure that all bystanders have cleared the area.

NOTE:

Indicator (A) should be at position **0** (B) when the header is 254–356 mm (10–14 in.) above the ground. When the header is on the ground, the indicator should be at position **1** (C) for low ground pressure, and at position **4** (D) for high ground pressure. Crop and soil conditions determine the amount of float to use. The ideal float setting is as light as possible without the header bouncing or missing crop. Operating with a heavy float setting prematurely wears the cutterbar wearplates.

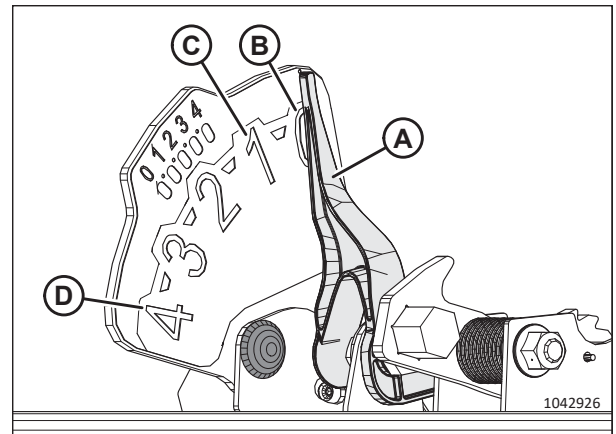

Figure 8.32: Float Indicator

SETTING UP AUTO HEADER HEIGHT CONTROL SYSTEM

1. Engage the separator and the header.
2. Move the header to the desired cutting height.
3. Press 1 on button (A). A yellow indicator next to the button will light up.

NOTE:

Always set the header position **BEFORE** setting the reel position. If the header and the reel are set at the same time, the reel setting will not be saved.

4. Move the reel to the desired working position.
5. Press 1 on button (A). A yellow indicator next to the button will light up.



Figure 8.33: Case Combine Console

6. Move the header to a second desired cutting height.
7. Press 2 on button (A). A yellow indicator next to the button will light up.
8. Move the reel to the desired working position.
9. Press 2 on button (A). A yellow indicator next to the button will light up.



Figure 8.34: Case Combine Console

The up and down arrows should now appear in MANUAL HEIGHT box (A) on the RUN 1 page on the combine display. This indicates that the auto header height control (AHHC) is functioning.



Figure 8.35: Case Combine Display – Run 1 Page

SETTING UP AUTO HEADER HEIGHT CONTROL SYSTEM

10. To enable the preset cutting heights, activate AHHC button (A) to place the header on the ground. To enable the first preset, tap the button once. To enable the second preset, tap the button twice.

To lift the header to its maximum working height, hold the SHIFT button behind the control handle while pressing AHHC button (A).



Figure 8.36: Case Combine Control Handle

11. The maximum working height can be adjusted on the HEADER SETUP page on the combine display. Enter the desired height in MAXIMUM WORKING HEIGHT field (A).



Figure 8.37: Case Combine Display – Header Setup Page

12. If necessary, adjust the position of one of the presets by using button (A) on the combine console.



Figure 8.38: Case Combine Console

8.1.6 Case IH 120, 230, 240, and 250 Series Combines

To make your header's auto header height control (AHHC) system compatible with the combine, configure the reel speed settings, set up the AHHC controls, and calibrate the AHHC system to ensure that it is working correctly.

Checking Voltage Range from Combine Cab – Case IH, 120, 230, 240, and 250 Series Combines

In order for the auto header height control (AHHC) system to work correctly, the header height sensors must detect the correct voltage readings. The sensor outputs can be viewed using the combine display.

NOTE:

Changes may have been made to the combine controls or the display since this document was published. For the most up-to-date information, refer to the combine operator's manual.

⚠ DANGER

To prevent bodily injury or death from the unexpected start-up of the machine, always stop the engine and remove the key from the ignition before making adjustments to the machine.

⚠ DANGER

Ensure that all bystanders have cleared the area.

1. Position the header so that the cutterbar is 254–356 mm (10–14 in.) off the ground.
2. Shut down the engine, and remove the key from the ignition.
3. Unlock the header float. For instructions, refer to the header operator's manual.

⚠ CAUTION

To prevent cuts, pinches, and other bodily harm to the person checking the down stops, ensure that nobody is manually lifting, bouncing, or moving the header in any way while the down stop washer is being touched and checked for movement.

4. Ensure that the float lock linkage is on the down stops (washer [A] cannot move) at both locations.

NOTE:

If the header is **NOT** on the down stops, the voltage may go out of range during operation and cause the AHHC system to malfunction. To fix the problem, make the header heavier by decreasing the float. For instructions, refer to [6.10 Checking and Adjusting Header Float, page 229](#).

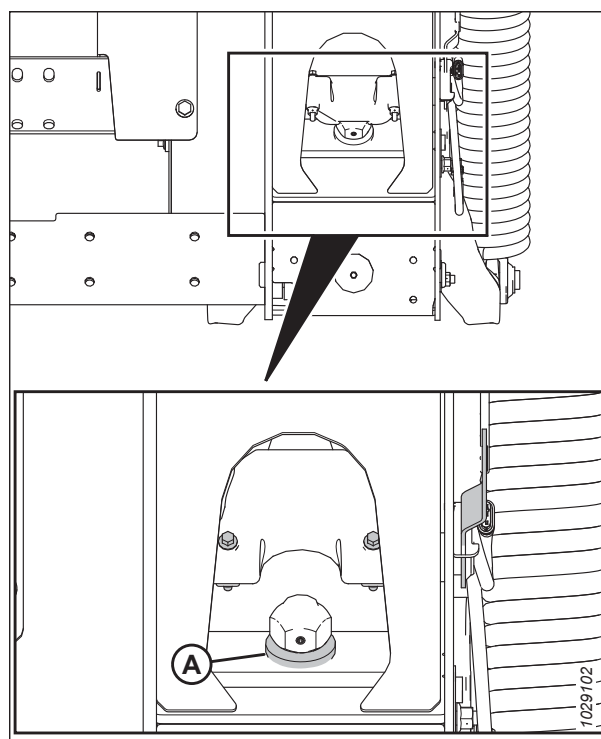

Figure 8.39: Down Stop Washer

SETTING UP AUTO HEADER HEIGHT CONTROL SYSTEM

5. If the pointer is not on zero, loosen bolt (A) and slide float indicator plate (B) until pointer (C) is on 0 (D). Tighten the nut on bolt (A).

NOTE:

Use zero dot (E) above the decal to correctly set the indicator needle.

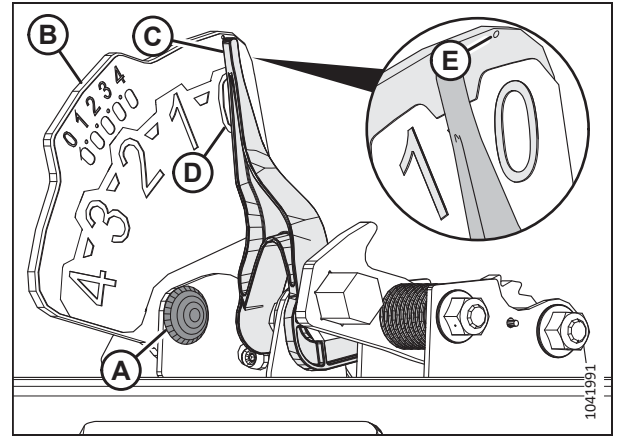

Figure 8.40: Float Indicator

6. Ensure the header float is unlocked.
7. Select DIAGNOSTICS (A) on the MAIN page. The DIAGNOSTICS page opens.
8. Select SETTINGS. The SETTINGS page opens.

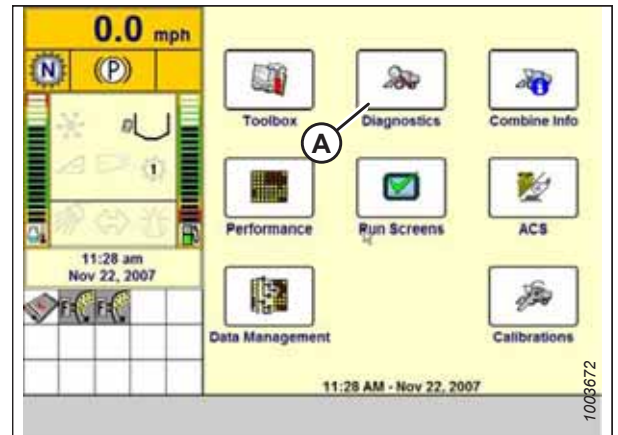

Figure 8.41: Case IH Combine Display

9. Select GROUP drop-down menu (A). The GROUP dialog box opens.

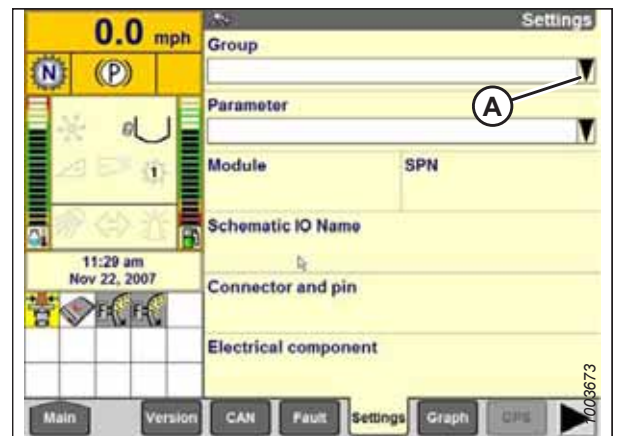

Figure 8.42: Case IH Combine Display

SETTING UP AUTO HEADER HEIGHT CONTROL SYSTEM

10. Select HEADER HEIGHT/TILT (A). The PARAMETER page opens.

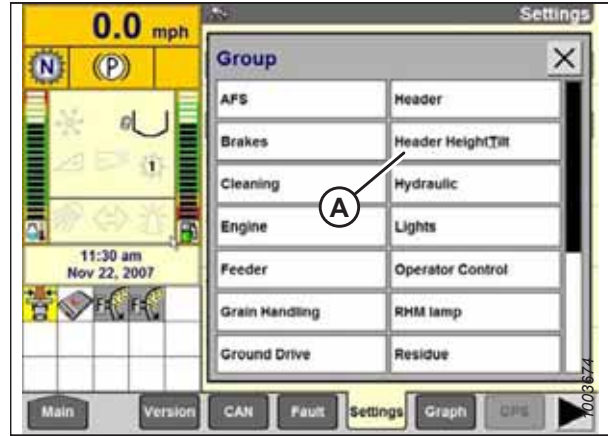

Figure 8.43: Case IH Combine Display

11. Select LEFT HEADER HEIGHT SEN (A), and then select GRAPH button (B). The exact voltage is displayed at top of page. Raise and lower the header to see the full range of voltage readings.
12. If the sensor voltage is not within the lower and upper limits, or if the range between the lower and upper limits is insufficient, refer to [8.1.3 Manually Checking Voltage Limits, page 269](#).

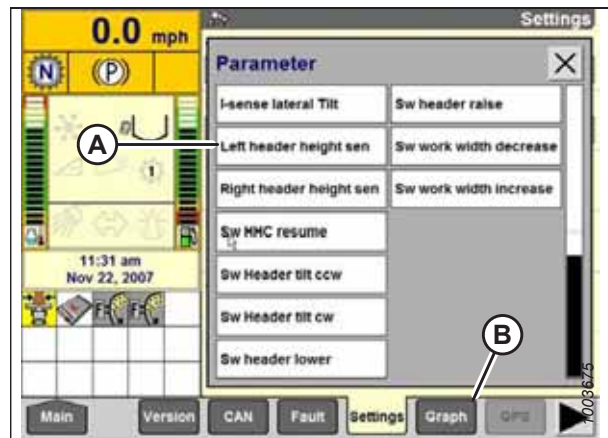

Figure 8.44: Case IH Combine Display

Header Settings Quick Reference – Case IH 120, 230, 240, and 250 Series

The recommended auto header height control (AHC) settings for a D2 Series Draper Header operating with a Case IH 120, 230, 240, and 250 Series combine are provided.

NOTE:

The setting options vary based on the software version of the combine. For software version 28.00 or higher, refer to [Table 8.3, page 286](#); for lower versions, refer to [Table 8.4, page 287](#).

Table 8.3 Header Settings – Case IH 120, 230, 240, and 250 Series (Software Version 28.00 or Higher)

Setup Parameter	Suggested Setting
Header Sub Type	<ul style="list-style-type: none"> If software version 36.4.X.X or later is installed: FD2/D2 SERIES If a software version prior to version 36.4.X.X is installed: 2000
Frame Type	RIGID
Header Sensors	ENABLE
Header Pressure Float	NO
Height/Tilt Response	FAST
Auto Height Override	YES

SETTING UP AUTO HEADER HEIGHT CONTROL SYSTEM

Table 8.3 Header Settings – Case IH 120, 230, 240, and 250 Series (Software Version 28.00 or Higher) (continued)

Setup Parameter	Suggested Setting	
HHC Height Sensitivity ²²	Two-sensor system	250
	One-sensor system	180
HHC Tilt Sensitivity	150	
Reel Height Sensor	YES	
Autotilt	Two-sensor system	YES
	One-sensor system	NO

Table 8.4 Header Settings – Case IH 120, 230, 240, and 250 Series (Below Software Version 28.00)

Setup Parameter	Suggested Setting	
Header Style	RIGID	
Auto Reel Speed Slope	133	
Header Pressure Float	NO	
Reel Drive	HYDRAULIC	
Reel Fore-Back	YES	
HHC Height Sensitivity ²²	Two-sensor system	250
	One-sensor system	180
HHC Tilt Sensitivity	150	
Fore/Aft Control	YES	
HDR Fore/Aft Tilt	YES	
Header Type (HEAD2 tab)	DRAPER	
Cutting Type	PLATFORM	
Header Width	Set according to header specification	
Header Usage	Set according to header specification	
Reel Height Sensor	YES	
Autotilt	Two-sensor system	YES
	One-sensor system	NO

Calibrating Auto Header Height Control – Case IH 120, 230, 240, and 250 Series Combines with Software Version below 28.00

The auto header height control (AHHC) sensor output must be calibrated for each combine, or the AHHC feature will not work properly.

NOTE:

This procedure applies to combines with a software version below 28.00. For instructions on calibrating the AHHC for combines with software version 28.00 or above, refer to [Calibrating Auto Header Height Control – Case IH Combines with Version 28.00 or Higher Software, page 292](#).



DANGER

To prevent bodily injury or death from the unexpected start-up of the machine, always stop the engine and remove the key from the ignition before making adjustments to the machine.

22. If hunting occurs during operation, decrease the HHC HEIGHT SENSITIVITY setting by 20 points at a time until hunting no longer occurs.

SETTING UP AUTO HEADER HEIGHT CONTROL SYSTEM

DANGER

Ensure that all bystanders have cleared the area.

NOTE:

Changes may have been made to the combine controls or the display since this document was published. For the most up-to-date information, refer to the combine operator's manual.

NOTE:

If the header float is set too light, it can prevent the calibration of the AHHC. In order to prevent the header from separating from the float module, it may be necessary to change the float to a heavier setting during calibration.

1. Park the combine on a level surface.
2. Ensure that the header is level with the ground. If adjustment is required, refer to [10.5 Leveling Header, page 526](#).

NOTE:

Spirit level (A) is located on top of the float module frame. The header is level if the bubble is in the center of the spirit level.

3. Ensure that the center-link is set to **D**.

NOTE:

When calibration is complete, adjust the center-link back to the desired header angle. For instructions, refer to the header operator's manual.

4. Adjust the reel fore-aft position so that the indicator is at position **6**.
5. Position the header so that the cutterbar is 254–356 mm (10–14 in.) off the ground.
6. Shut down the engine, and remove the key from the ignition.

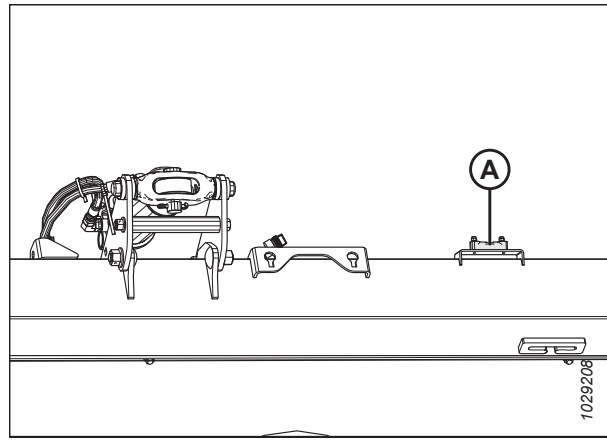

Figure 8.45: Spirit Level

SETTING UP AUTO HEADER HEIGHT CONTROL SYSTEM

CAUTION

To prevent cuts, pinches, and other bodily harm to the person checking the down stops, ensure that nobody is manually lifting, bouncing, or moving the header in any way while the down stop washer is being touched and checked for movement.

7. Ensure that the float lock linkage is on the down stops (washer [A] cannot move) at both locations.

NOTE:

If the header is **NOT** on the down stops, the voltage may go out of range during operation and cause the AHHC system to malfunction. To fix the problem, make the header heavier by decreasing the float. For instructions, refer to [6.10 Checking and Adjusting Header Float, page 229](#).

8. Unlock the header float. For instructions, refer to the header operator's manual.

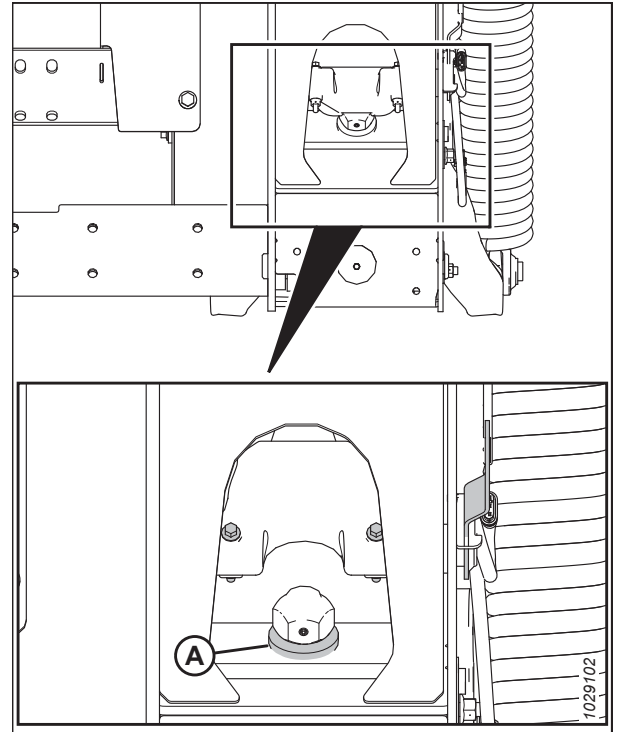

Figure 8.46: Down Stop Washer

9. Select TOOLBOX icon (A) on the main page.

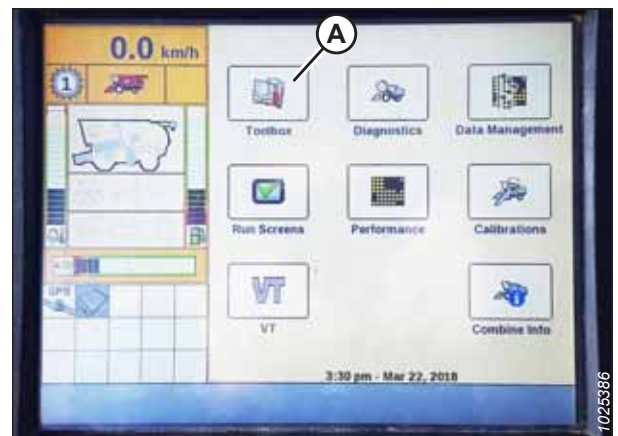

Figure 8.47: Case IH Combine Display

SETTING UP AUTO HEADER HEIGHT CONTROL SYSTEM

10. Select HEADER tab (A).

NOTE:

To locate the HEADER tab, you may need to use side arrows (C).

11. Set HEADER STYLE (B) to RIGID.

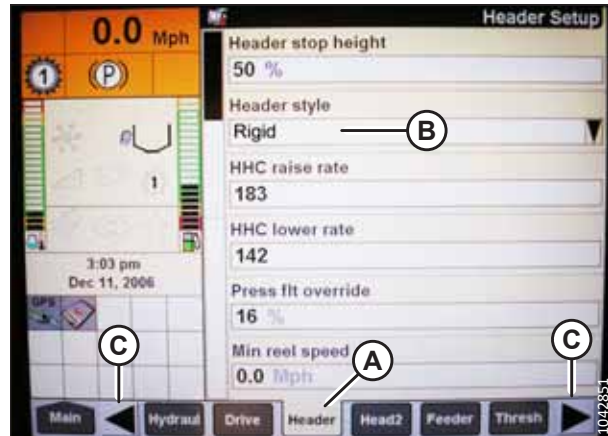

Figure 8.48: Case IH Combine Display

12. Set AUTO REELSPEED SLOPE.

NOTE:

The AUTO REELSPEED SLOPE value automatically maintains the speed of the reel relative to ground speed. For example, if the value is set to 133, then the reel's rotational speed will be higher than the combine's ground speed. In general, the reel's speed should be higher than the combine's ground speed; however, adjust the value according to crop conditions.

13. Set HEADER PRESSURE FLOAT to NO. Ensure that REEL DRIVE is set to HYDRAULIC.

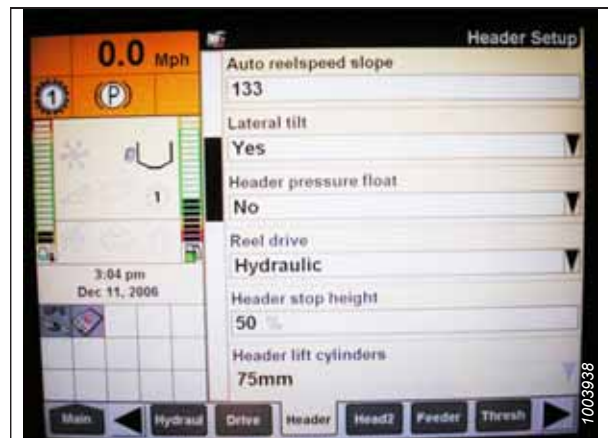

Figure 8.49: Case IH Combine Display

14. Set REEL FORE-BACK to YES (if applicable).

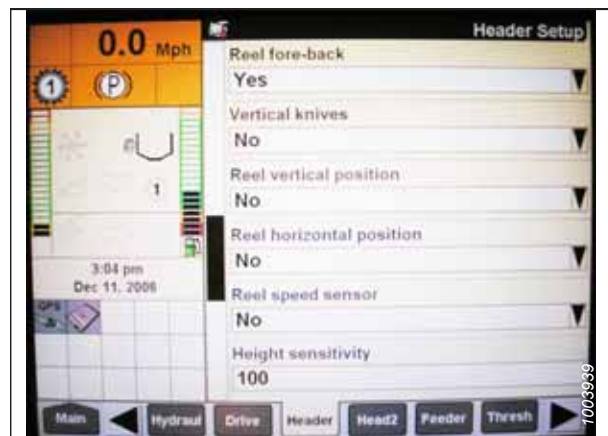

Figure 8.50: Case IH Combine Display

SETTING UP AUTO HEADER HEIGHT CONTROL SYSTEM

15. Locate HHC HEIGHT SENSITIVITY field (A), and set it as follows:

- **Two-sensor systems:** Set HHC HEIGHT SENSITIVITY to 250.
- **Single-sensor systems:** Set HHC HEIGHT SENSITIVITY to 180.

NOTE:

If the combine continually raises and lowers the header during operation (a behavior termed “hunting”), decrease the HHC HEIGHT SENSITIVITY setting by 20 points at a time until hunting no longer occurs.

16. Set HHC TILT SENSITIVITY (B) to 150. Adjust the sensitivity as desired.

17. Set FORE/AFT CONTROL and HDR FORE/AFT TILT to YES (if applicable).



Figure 8.51: Case IH Combine Display



Figure 8.52: Case IH Combine Display

18. Press HEAD2 (A) at the bottom of the page.

19. Ensure that HEADER TYPE (B) is set to DRAPER.

NOTE:

If the recognition resistor is plugged in to the header harness, you will not be able to change this setting.

20. Set CUTTING TYPE (C) to PLATFORM.

21. Set HEADER WIDTH (D) and HEADER USAGE (E) to the appropriate values.

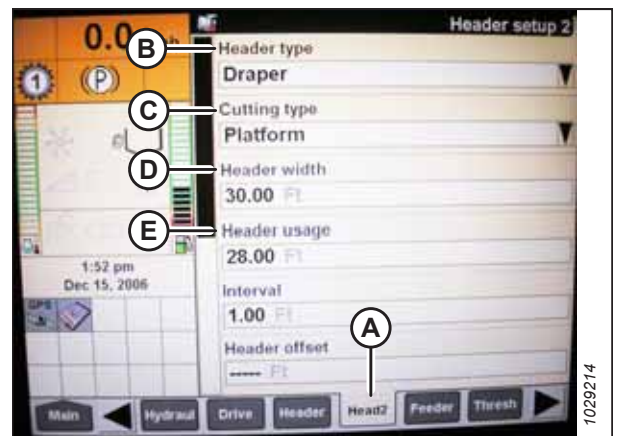

Figure 8.53: Case IH Combine Display

SETTING UP AUTO HEADER HEIGHT CONTROL SYSTEM

22. From the REEL HEIGHT SENSOR menu, select YES (A).



Figure 8.54: Case IH Combine Display

23. Locate AUTOTILT field (A) and set it as follows:

- **Two-sensor system:** Select YES.
- **Single-sensor system:** Select NO.

NOTE:

If the float was changed to a heavier setting to complete the AHHC calibration procedure, adjust it to the recommended operating float after calibration is complete.



Figure 8.55: Case IH Combine Display

Calibrating Auto Header Height Control – Case IH Combines with Version 28.00 or Higher Software

Calibrate the auto header height control (AHHC) sensor output for each combine.

DANGER

To prevent bodily injury or death from the unexpected start-up of the machine, always stop the engine and remove the key from the ignition before making adjustments to the machine.

DANGER

Ensure that all bystanders have cleared the area.

NOTE:

Changes may have been made to the combine controls or the display since this document was published. For the most up-to-date information, refer to the combine operator's manual.

NOTE:

If the header float is set too light, it can prevent the calibration of the AHHC. In order to prevent the header from separating from the float module, it may be necessary to change the float to a heavier setting during calibration.

SETTING UP AUTO HEADER HEIGHT CONTROL SYSTEM

1. Park the combine on a level surface.
2. Ensure that the header is level with the ground. If adjustment is required, refer to [10.5 Leveling Header, page 526](#).

NOTE:

Spirit level (A) is located on top of the float module frame. The header is level if the bubble is in the center of the spirit level.

3. Ensure that the center-link is set to **D**.

NOTE:

When calibration is complete, adjust the center-link back to the desired header angle. For instructions, refer to the header operator's manual.

4. Adjust the reel fore-aft position so that the indicator is at position **6**.
5. Position the header so that the cutterbar is 254–356 mm (10–14 in.) off the ground.
6. Shut down the engine, and remove the key from the ignition.



CAUTION

To prevent cuts, pinches, and other bodily harm to the person checking the down stops, ensure that nobody is manually lifting, bouncing, or moving the header in any way while the down stop washer is being touched and checked for movement.

7. Ensure that the float lock linkage is on the down stops (washer [A] cannot move) at both locations.

NOTE:

If the header is **NOT** on the down stops, the voltage may go out of range during operation and cause the AHHC system to malfunction. To fix the problem, make the header heavier by decreasing the float. For instructions, refer to [6.10 Checking and Adjusting Header Float, page 229](#).

8. Unlock the header float. For instructions, refer to the header operator's manual.

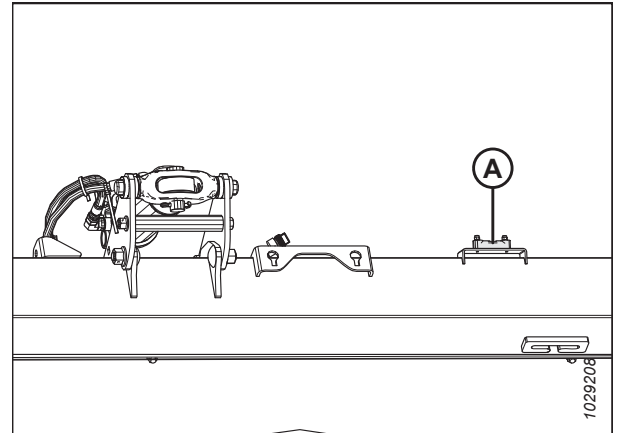

Figure 8.56: Spirit Level

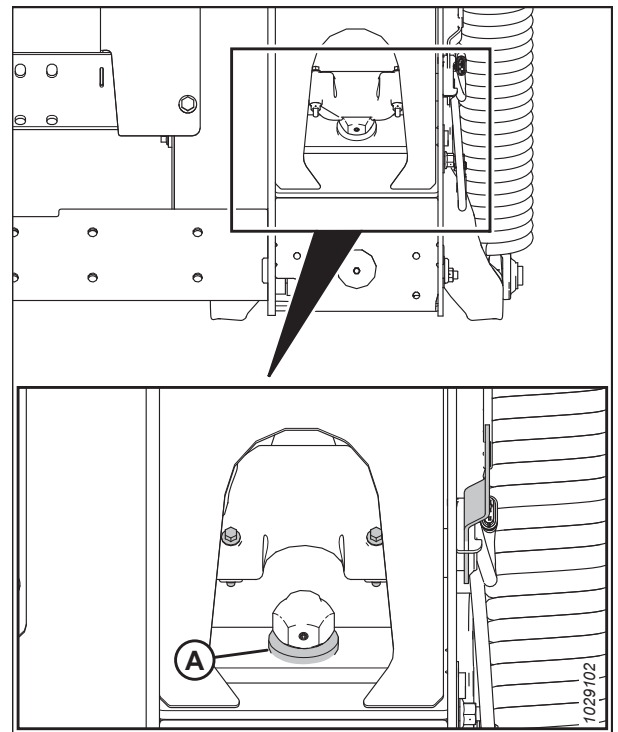

Figure 8.57: Down Stop Washer

SETTING UP AUTO HEADER HEIGHT CONTROL SYSTEM

9. To view the software version, select the DIAGNOSTICS button from the Home Screen, then select VERSION tab (A).
10. Ensure that the software version is **28.00 or higher**.



Figure 8.58: Case IH Combine Display

Adjusting combine display settings

11. Select TOOLBOX icon (A) on the MAIN page.

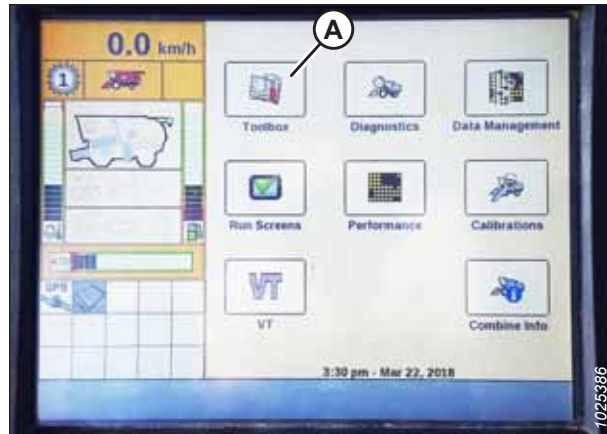

Figure 8.59: Case IH Combine Display

12. Select HEAD 1 tab (A).

NOTE:

To locate the HEAD 1 tab, you may need to use side arrows (B).

13. Locate HEADER SUB TYPE field (C).

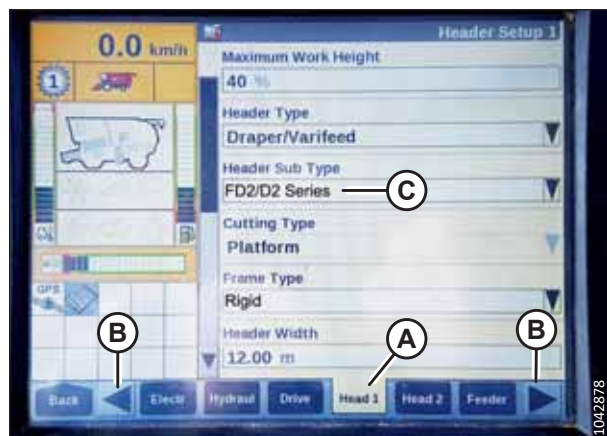

Figure 8.60: Case IH Combine Display

SETTING UP AUTO HEADER HEIGHT CONTROL SYSTEM

14. Select the following value from the HEADER SUB TYPE field:

- If software version 36.4.X.X or later is installed, select FD2/D2 SERIES (A).

NOTE:

Selecting FD2/D2 SERIES will optimize AHHC performance on D2 Series Draper Headers.

- If a software version prior to version 36.4.X.X is installed, select **2000** (B).



Figure 8.61: Case IH Combine Display

15. Return to the HEAD 1 page and choose RIGID from FRAME TYPE drop-down menu (A).

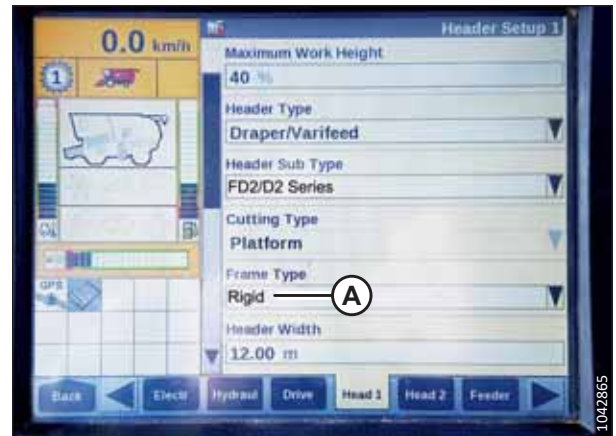

Figure 8.62: Case IH Combine Display

16. Select HEAD 2 tab (A).

17. In HEADER SENSORS field (B), select ENABLE.

18. In HEADER PRESSURE FLOAT field (C), select NO.

19. In HEIGHT/TILT RESPONSE field (D), select FAST.

20. In AUTO HEIGHT OVERRIDE field (E), select YES.

21. Press down arrow (F) to go to the next page.

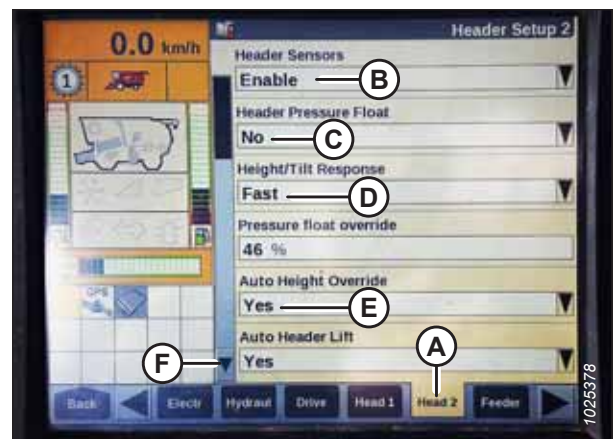

Figure 8.63: Case IH Combine Display

SETTING UP AUTO HEADER HEIGHT CONTROL SYSTEM

22. Locate HHC HEIGHT SENSITIVITY field (A), and set it as follows:

- **Single-sensor system:** Set HHC HEIGHT SENSITIVITY to 180.
- **Two-sensor system:** Set HHC HEIGHT SENSITIVITY to 250.

NOTE:

If the combine continually raises and lowers the header during operation (a behavior termed “hunting”), decrease the HHC HEIGHT SENSITIVITY setting by 20 points at a time until hunting no longer occurs.

23. Set HHC TILT SENSITIVITY (B) to 150. Adjust the sensitivity as desired.

24. From the REEL HEIGHT SENSOR menu, select YES (A).



Figure 8.64: Case IH Combine Display



Figure 8.65: Case IH Combine Display

25. Scroll to the AUTOTILT field (A), and set it as follows:

- **Two-sensor system:** Select YES.
- **Single-sensor system:** Select NO.

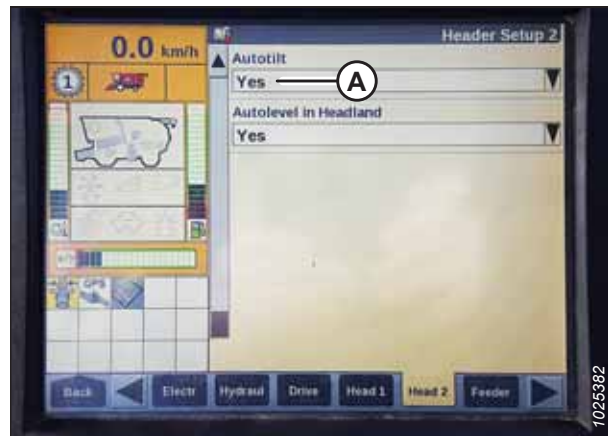

Figure 8.66: Case IH Combine Display

SETTING UP AUTO HEADER HEIGHT CONTROL SYSTEM

Calibrating auto header height control

26. Select CALIBRATION on the combine display and press the right arrow navigation key to enter the information box.
27. Select HEADER (A), and press ENTER. The CALIBRATION dialog box opens.

NOTE:

Use the UP and DOWN navigation keys to move between the different options.



Figure 8.67: Case IH Combine Display

28. Follow the calibration steps as they appear. As you proceed through the calibration process, the display automatically updates to show the next step.

NOTE:

Pressing the ESC key during any of the steps or letting the system sit idle for over 3 minutes will stop the calibration procedure.

NOTE:

Refer to your combine operator's manual for an explanation of any error codes.

29. When all of the steps have been completed, CALIBRATION SUCCESSFUL displays on the page. Exit the CALIBRATION menu by pressing the ENTER or ESC key.



Figure 8.68: Case IH Combine Display

NOTE:

If the float was set heavier to complete calibration, adjust the header to the recommended operating float after calibration is complete.

30. Ensure that AUTO HEIGHT icon (A) appears on the monitor as shown at location (B). When the header is set for cutting on the ground, this verifies that the combine is correctly using the sensor on the header to detect the ground pressure.

NOTE:

Icons (A) and (B) appear on the monitor only after engaging the separator and header, and then pressing HEADER RESUME button on the control panel.

NOTE:

AUTO HEIGHT field (B) may appear on any of the RUN tabs and not necessarily on the RUN 1 tab.



Figure 8.69: Case IH Combine Display

SETTING UP AUTO HEADER HEIGHT CONTROL SYSTEM

Checking Reel Height Sensor Voltages – Case IH Combines

The voltage output of the reel height sensors can be inspected using the combine display in the cab.

DANGER

Ensure that all bystanders have cleared the area.

NOTE:

Changes may have been made to the combine controls or the display since this document was published. For the most up-to-date information, refer to the combine operator's manual.

1. On the main page of the combine display, select DIAGNOSTICS (A). The DIAGNOSTICS page appears.

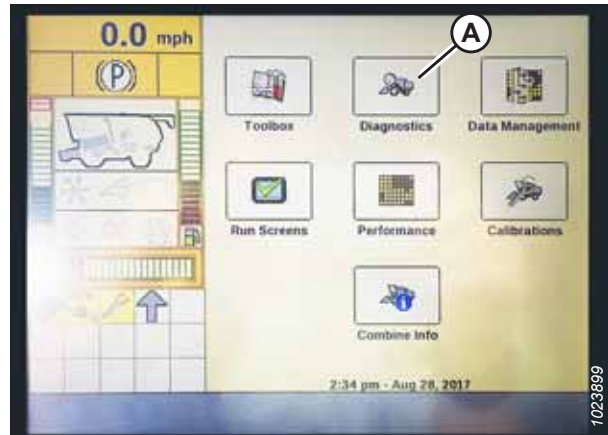

Figure 8.70: Case IH Combine Display

2. Select SETTINGS tab (A). The SETTINGS page appears.
3. From the GROUP menu, select HEADER (B).
4. From the PARAMETER menu, select REEL VERTICAL POSITION (C).



Figure 8.71: Case IH Combine Display

SETTING UP AUTO HEADER HEIGHT CONTROL SYSTEM

5. Select GRAPH tab (A). The REEL VERTICAL POSITION graph appears.
6. Lower the reel to view upper voltage (B). The voltage should be within 4.1–4.3 V.
7. Raise the reel to view lower voltage (C). The voltage should be within 0.7–0.9 V.
8. If either voltage is out of range, refer to [7.1 Checking and Adjusting Reel Height Sensor](#), page 259.

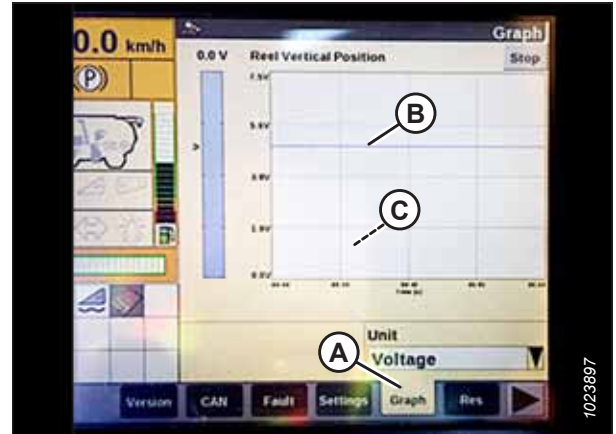

Figure 8.72: Case IH Combine Display

Setting Preset Cutting Height – Case IH 120, 230, 240, and 250 Series Combines

Once the auto header height control (AHHC) system has been configured to work with the header, the preset cutting height can be configured. The preset cutting height refers to the header height that the AHHC system will attempt to maintain as the combine moves forward.

DANGER

Ensure that all bystanders have cleared the area.

NOTE:

Changes may have been made to the combine controls or the display since this document was published. For the most up-to-date information, refer to the combine operator's manual.

NOTE:

Indicator (A) should be at position **0** (B) with the header 254–356 mm (10–14 in.) off the ground. When the header is on the ground, the indicator should be at position **1** (C) for low ground pressure, and at position **4** (D) for high ground pressure. The crop and soil conditions determine the amount of float to use. The ideal setting is as light as possible without the header bouncing or missing crop. Operating with heavy settings prematurely wears the cutterbar wearplates.

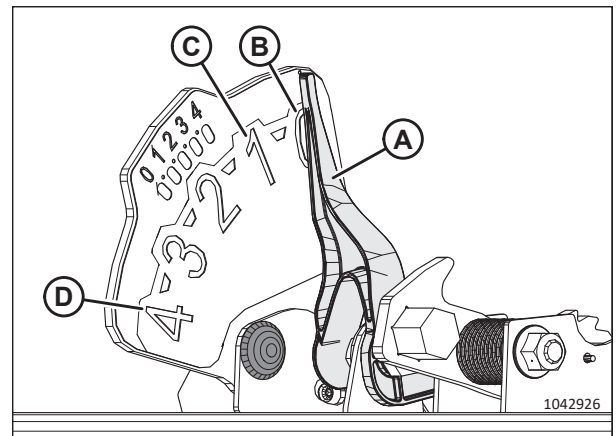

Figure 8.73: Float Indicator

SETTING UP AUTO HEADER HEIGHT CONTROL SYSTEM

1. Engage the separator and the header.
2. Move the header to a desired cutting height.
3. Press SET #1 switch (A). The light beside switch (A) will light up.

NOTE:

Use switch (C) for fine adjustments.

NOTE:

When setting the presets, always set the header position before setting the reel position. If the header and the reel are set at the same time, the reel setting will not be saved.

4. Move the reel to the desired working position.
5. Press SET #1 switch (A). The light beside switch (A) will light up.
6. Move the header to a second desired cutting height.
7. Press SET #2 switch (B). The light beside switch (B) will light up.
8. Move the reel to a second desired working position.
9. Press SET #2 switch (B). The light beside switch (B) will light up.
10. To swap between the set points, press HEADER RESUME (A).
11. To raise the header, hold SHIFT button (B) behind the control handle and press HEADER RESUME switch (A). To lower the header, press HEADER RESUME switch (A). once to return to the header preset height.

NOTE:

Pressing HEADER RAISE/LOWER switches (C) and (D) disengages AUTO HEIGHT mode. Press HEADER RESUME (A) to re-engage AUTO HEIGHT mode.



Figure 8.74: Case Combine Controls



Figure 8.75: Case Combine Controls

Reel Reverse Function – Case IH Combines

With the installation of Case kit 91826802, Case IH Flagship combines can allow the reel to reverse with the feeder house.

DANGER

Ensure that all bystanders have cleared the area.

NOTE:

Changes may have been made to the combine controls or the display since this document was published. For the most up-to-date information, refer to the combine operator's manual.

SETTING UP AUTO HEADER HEIGHT CONTROL SYSTEM

1. Select TOOLBOX (A) on the MAIN page.

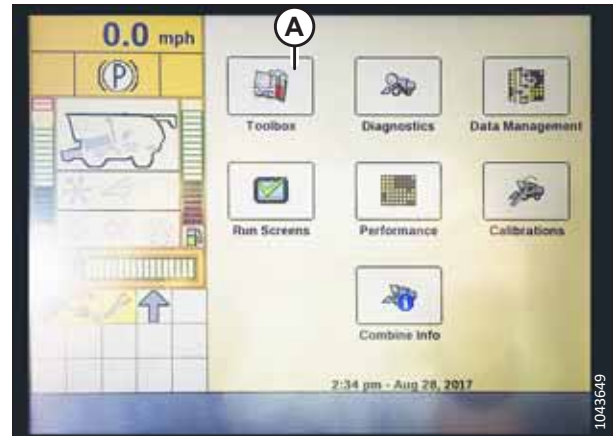

Figure 8.76: Case IH Combine Display

2. Select HEAD 1 tab (A).

NOTE:

To locate the HEAD 1 tab, you may need to use side arrows (B).

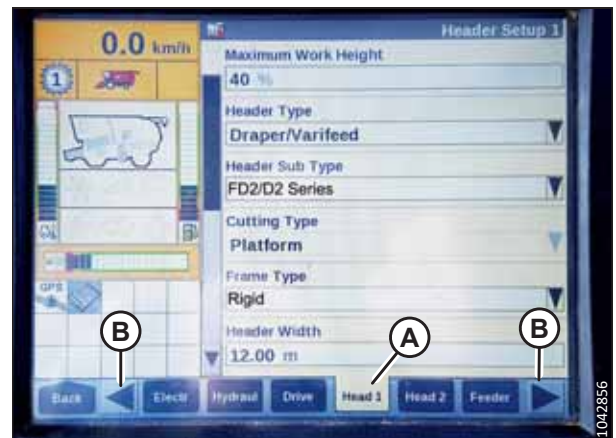

Figure 8.77: Case IH Combine Display

3. Locate the HEADER SUB TYPE field.
4. Select the following value from the HEADER SUB TYPE field:

- If software version 36.4.X.X or later is installed, select FD2/D2 SERIES (A).

NOTE:

Selecting FD2/D2 SERIES will optimize AHHC performance on D2 Series Draper Headers.

- If a software version prior to version 36.4.X.X is installed, select **2000** (B).



Figure 8.78: Case IH Combine Display

SETTING UP AUTO HEADER HEIGHT CONTROL SYSTEM

- Return to the HEAD 1 page and choose RIGID from FRAME TYPE drop-down menu (A).

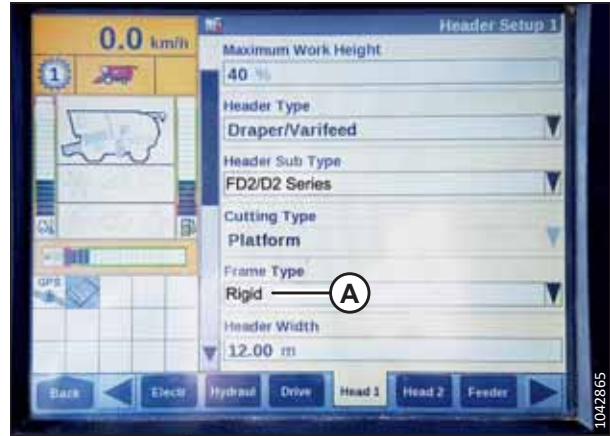

Figure 8.79: Case IH Combine Display

- Select HEAD 2 tab (A).
- In HEADER SENSORS field (B), select ENABLE.
- In HEADER PRESSURE FLOAT field (C), select NO.
- In HEIGHT/TILT RESPONSE field (D), select FAST.

NOTE:

AUTO HEADER LIFT field (E) can be set to the user's preference.

- Press down arrow (F) to go to the next page.



Figure 8.80: Case IH Combine Display

- In HYDRAULIC REEL field (A), select YES.
- In HYDRAULIC REEL REVERSE field (B), select YES.



Figure 8.81: Case IH Combine Display

SETTING UP AUTO HEADER HEIGHT CONTROL SYSTEM

13. In OVERLAP MODE field (A), select MANUAL.
14. In WORK WIDTH RESET field (B), select MANUAL.

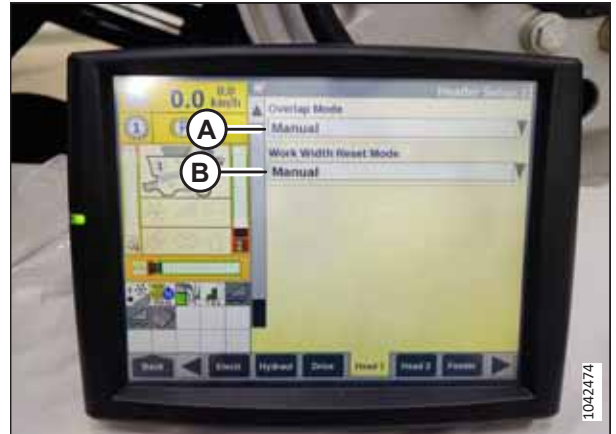

Figure 8.82: Case IH Combine Display

Side Draper Speed Control – Case IH Combines

The lateral belt speed can be adjusted on the touch screen display, for software version 34 and later.

DANGER

Ensure that all bystanders have cleared the area.

NOTE:

Changes may have been made to the combine controls or the display since this document was published. For the most up-to-date information, refer to the combine operator's manual.

1. Select HEAD 1 tab (A).

NOTE:

To locate the HEAD 1 tab, you may need to use side arrows (B).

2. Locate HEADER SUB TYPE field (C).

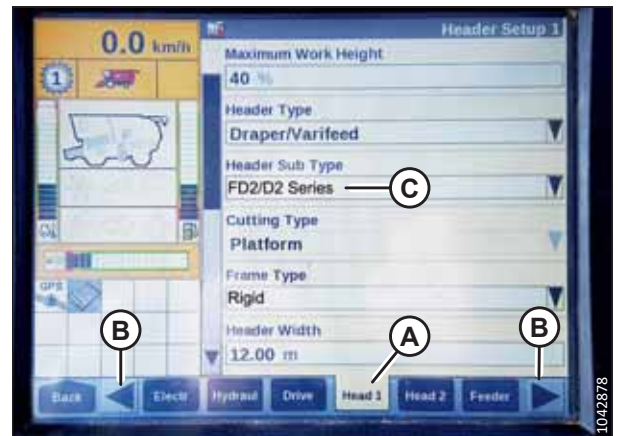

Figure 8.83: Case IH Combine Display

SETTING UP AUTO HEADER HEIGHT CONTROL SYSTEM

3. Select the following from the HEADER SUB TYPE field:
 - If software version 36.4.X.X or later is installed, select FD2/D2 SERIES (A).

NOTE:

Selecting FD2/D2 SERIES will optimize AHHC performance on D2 Series Draper Headers.

- If a software version prior to version 36.4.X.X is installed, select 2000 (B).



Figure 8.84: Case IH Combine Display

4. Use scrollbar (A) to navigate down to LATERAL BELT SPD (B).

NOTE:

The lateral belt speed can be adjusted using side arrows (C). Select ENTER (D) after adjusting the belt speed.

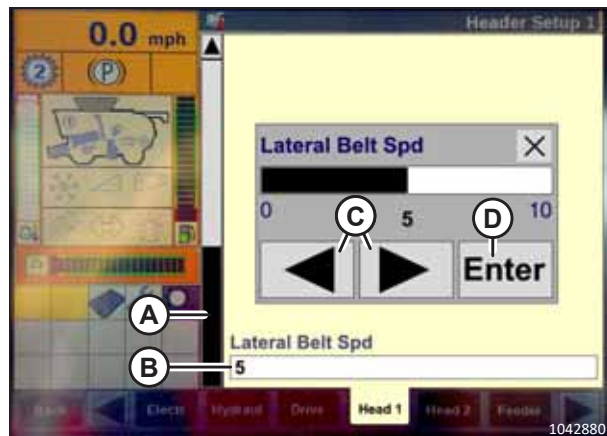

Figure 8.85: Case IH Combine Display

5. Navigate to RUN4 tab (A).
6. In WORK CONDITION field (B), select AUTO-DEFAULT.

NOTE:

The lateral belt speed can be adjusted by selecting LATERAL BELT SPD field (C).

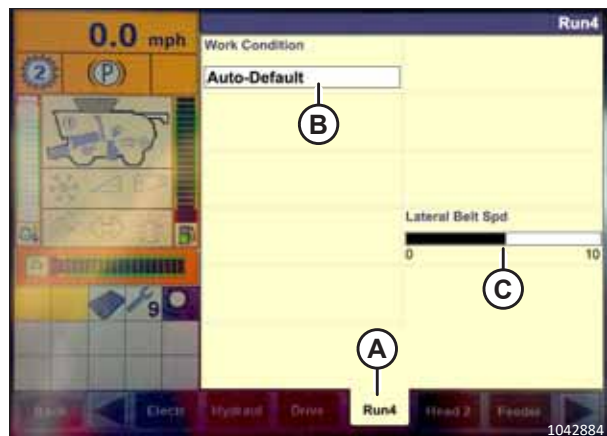

Figure 8.86: Case IH Combine Display

SETTING UP AUTO HEADER HEIGHT CONTROL SYSTEM

Reel Speed Sensor Compatibility – Case IH Combines

The reel speed settings can be adjusted using the touch screen display, for software version 34 and later.

DANGER

Ensure that all bystanders have cleared the area.

NOTE:

Changes may have been made to the combine controls or the display since this document was published. For the most up-to-date information, refer to the combine operator's manual.

1. Select HEAD 2 tab (A).

NOTE:

To locate the HEAD 2 tab, you may need to use side arrows (C).

2. In REEL SPEED SENSOR field (B), select YES.

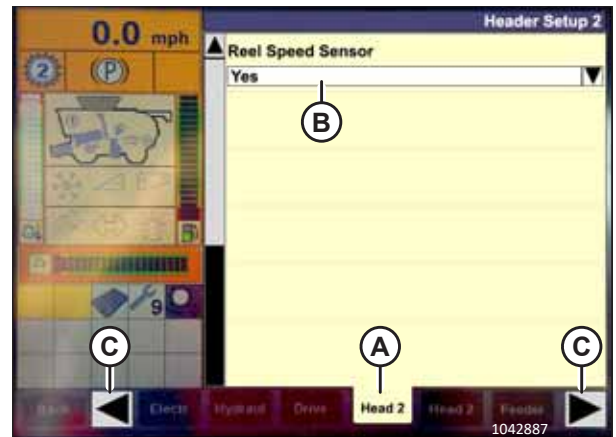

Figure 8.87: Case IH Combine Display

3. Select HEAD 2 tab (A).
4. Locate REEL SPROCKETS RATIO field (B), and select the appropriate sprocket ratio.

NOTE:

Sprocket ratio 19/56 is the default setting, while sprocket ratios 10/56 and 20/52 are optional settings.

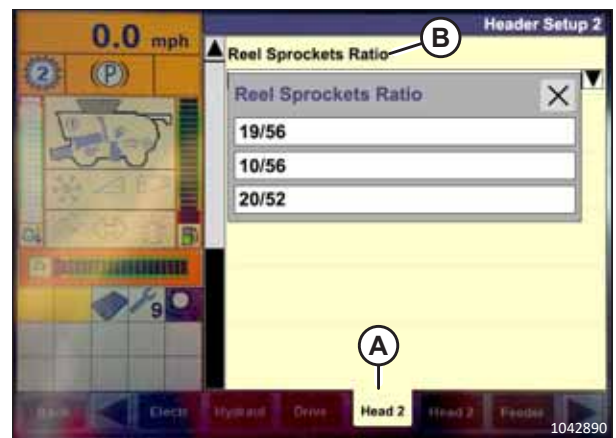

Figure 8.88: Case IH Combine Display

8.1.7 Challenger® and Massey Ferguson® 6 and 7 Series Combines

To make your header's auto header height control (AHHC) system compatible with the combine, configure the reel speed settings, set up the AHHC controls, and calibrate the AHHC system to ensure that it is working correctly.

Checking Voltage Range from Combine Cab – Challenger® and Massey Ferguson®

The auto header height control sensor needs to operate within a specific voltage range in order to work properly.

NOTE:

Changes may have been made to the combine controls or the display since this document was published. For the most up-to-date information, refer to the combine operator's manual.

⚠ DANGER

To prevent bodily injury or death from the unexpected start-up of the machine, always stop the engine and remove the key from the ignition before making adjustments to the machine.

⚠ DANGER

Ensure that all bystanders have cleared the area.

1. Position the header so that the cutterbar is 254–356 mm (10–14 in.) off the ground.
2. Shut down the engine, and remove the key from the ignition.
3. Unlock the header float. For instructions, refer to the header operator's manual.

⚠ CAUTION

To prevent cuts, pinches, and other bodily harm to the person checking the down stops, ensure that nobody is manually lifting, bouncing, or moving the header in any way while the down stop washer is being touched and checked for movement.

4. Ensure that the float lock linkage is on the down stops (washer [A] cannot move) at both locations.

NOTE:

If the header is **NOT** on the down stops, the voltage may go out of range during operation and cause the AHHC system to malfunction. To fix the problem, make the header heavier by decreasing the float. For instructions, refer to [6.10 Checking and Adjusting Header Float, page 229](#).

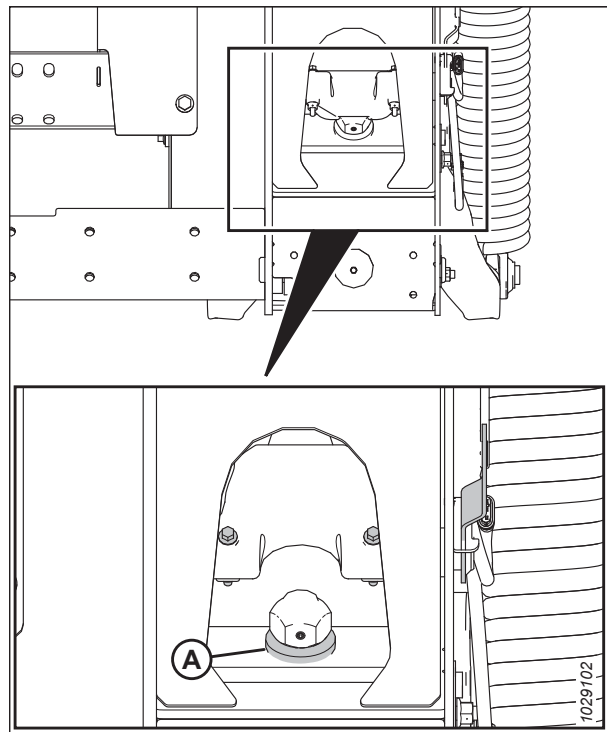

Figure 8.89: Down Stop Washer

SETTING UP AUTO HEADER HEIGHT CONTROL SYSTEM

- If the pointer is not on zero, loosen bolt (A) and slide float indicator plate (B) until pointer (C) is on 0 (D). Tighten the nut on bolt (A).

NOTE:

Use zero dot (E) above the decal to correctly set the indicator needle.

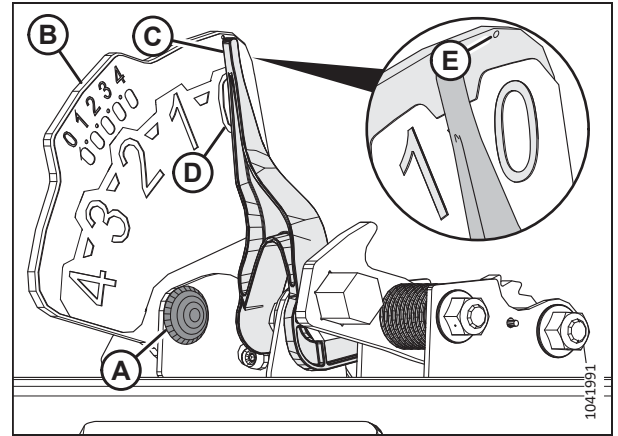

Figure 8.90: Float Indicator

- Go to the FIELD page on the combine monitor, and then press the diagnostics icon. The MISCELLANEOUS page appears.
- Select VMM DIAGNOSTIC (A). The VMM DIAGNOSTIC page appears.

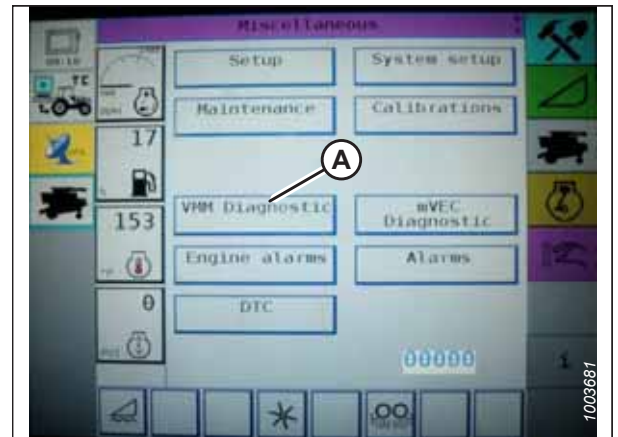

Figure 8.91: Challenger® Combine Display

- Go to ANALOG IN tab (A), and then select VMM MODULE 3 by selecting the text box below the four tabs. The voltage from the AHC sensor is now displayed on the page as HEADER HEIGHT RIGHT POT and HEADER HEIGHT LEFT POT. The readings may be slightly different.

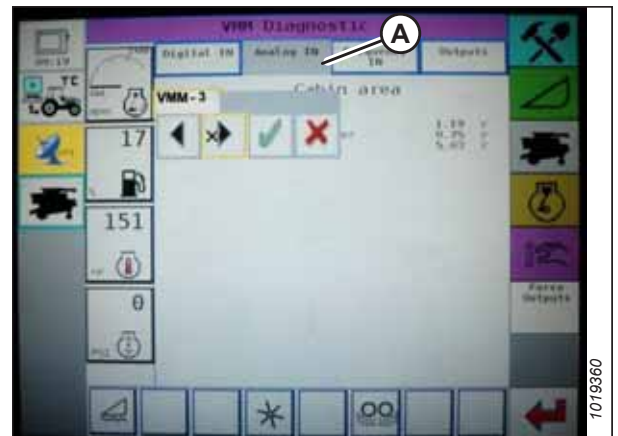

Figure 8.92: Challenger® Combine Display

SETTING UP AUTO HEADER HEIGHT CONTROL SYSTEM

- Fully lower the combine feeder house (the float module should be fully separated from the header).

NOTE:

You may need to hold the HEADER DOWN switch for a few seconds to fully lower the feeder house.

- Read the voltage.
- Raise the header 254–356 mm (10–14 in.) above the ground, and unlock the float.
- Read the voltage.
- If the sensor voltage is not within the lower and upper limits, or if the range between the lower and upper limits is insufficient, refer to [8.1.3 Manually Checking Voltage Limits](#), page 269.



Figure 8.93: Challenger® Combine Display

Engaging Auto Header Height Control – Challenger® and Massey Ferguson®

The auto header height control (AHHC) system must be engaged before its features can be configured.

NOTE:

Changes may have been made to the combine controls or the display since this document was published. For the most up-to-date information, refer to the combine operator’s manual.

The following system components are required in order for the AHHC to work:

- Main module (PCB board) and header driver module (PCB board) mounted in the card box in the fuse panel module (FP)
- Multifunction control handle operator inputs
- Operator inputs mounted in the control console module (CC) panel
- The electrohydraulic header lift control valve

To engage the AHHC, follow these steps:

- Scroll through the header control options on the combine display using the header control switch until AHHC icon (A) is displayed in the first message box. The AHHC will adjust the header height in relation to the ground according to the height setting and sensitivity setting.

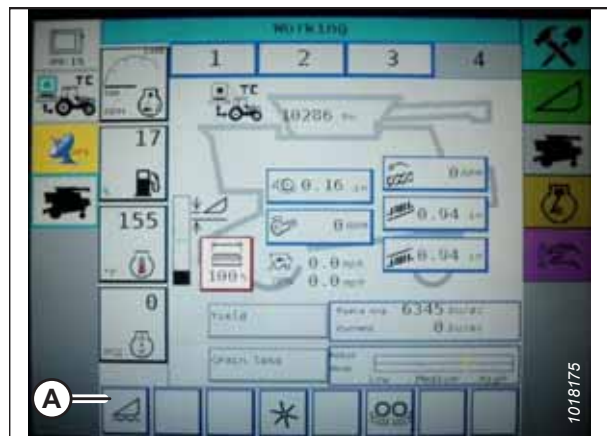

Figure 8.94: Challenger® Combine Display

SETTING UP AUTO HEADER HEIGHT CONTROL SYSTEM

Calibrating Auto Header Height Control – Challenger® and Massey Ferguson®

The auto header height control (AHHC) sensor output must be calibrated for each combine.

DANGER

To prevent bodily injury or death from the unexpected start-up of the machine, always stop the engine and remove the key from the ignition before making adjustments to the machine.

DANGER

Ensure that all bystanders have cleared the area.

NOTE:

Changes may have been made to the combine controls or the display since this document was published. For the most up-to-date information, refer to the combine operator's manual.

NOTE:

If the header float is set too light, it can prevent the calibration of the AHHC. In order to prevent the header from separating from the float module, it may be necessary to change the float to a heavier setting during calibration.

1. Park the combine on a level surface.
2. Ensure that the header is level with the ground. If adjustment is required, refer to [10.5 Leveling Header, page 526](#).

NOTE:

Spirit level (A) is located on top of the float module frame. The header is level if the bubble is in the center of the spirit level.

3. Ensure that the center-link is set to **D**.

NOTE:

When calibration is complete, adjust the center-link back to the desired header angle. For instructions, refer to the header operator's manual.

4. Adjust the reel fore-aft position so that the indicator is at position **6**.
5. Position the header so that the cutterbar is 254–356 mm (10–14 in.) off the ground.
6. Shut down the engine, and remove the key from the ignition.

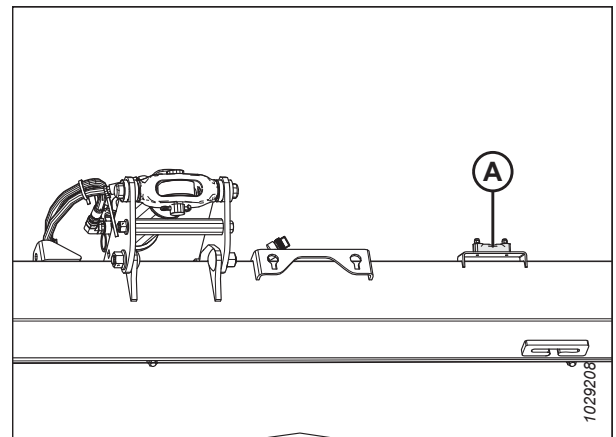

Figure 8.95: Spirit Level

SETTING UP AUTO HEADER HEIGHT CONTROL SYSTEM

CAUTION

To prevent cuts, pinches, and other bodily harm to the person checking the down stops, ensure that nobody is manually lifting, bouncing, or moving the header in any way while the down stop washer is being touched and checked for movement.

7. Ensure that the float lock linkage is on the down stops (washer [A] cannot move) at both locations.

NOTE:

If the header is **NOT** on the down stops, the voltage may go out of range during operation and cause the AHHC system to malfunction. To fix the problem, make the header heavier by decreasing the float. For instructions, refer to [6.10 Checking and Adjusting Header Float, page 229](#).

8. Unlock the header float. For instructions, refer to the header operator's manual.

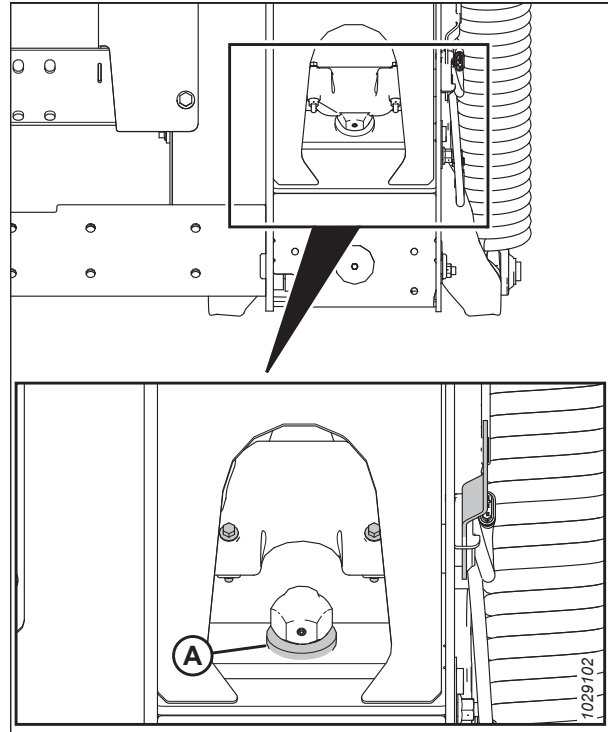

Figure 8.96: Down Stop Washer

9. On the FIELD page, select DIAGNOSTICS icon (A). The MISCELLANEOUS page appears.

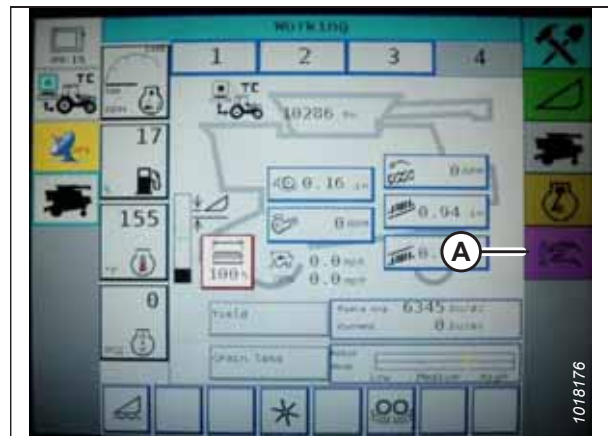

Figure 8.97: Challenger® Combine Display

SETTING UP AUTO HEADER HEIGHT CONTROL SYSTEM

10. Select CALIBRATIONS (A). The CALIBRATIONS page appears.

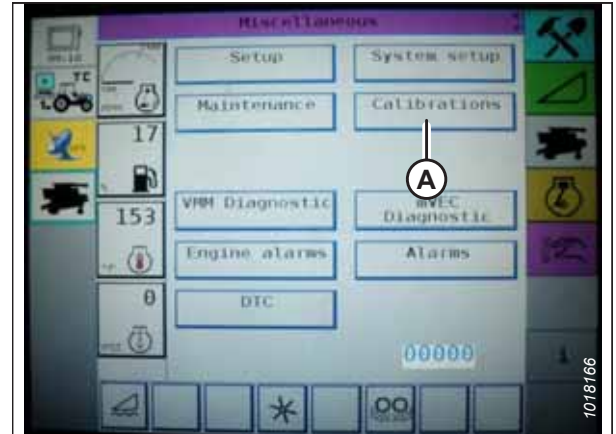

Figure 8.98: Challenger® Combine Display

11. Select HEADER (A). The HEADER CALIBRATION page displays a WARNING.



Figure 8.99: Challenger® Combine Display

12. Read the WARNING message, then select the green check mark button.



Figure 8.100: Challenger® Combine Display

SETTING UP AUTO HEADER HEIGHT CONTROL SYSTEM

13. Follow the on-screen prompts to complete calibration.

NOTE:

The calibration procedure can be canceled at any time by pressing the CANCEL button on the screen. While the header calibration is running, the calibration can also be canceled by using the UP, DOWN, TILT RIGHT, or TILT LEFT buttons on the control handle.

NOTE:

If the combine does not have HEADER TILT installed or if it is inoperable, you may receive warnings during calibration. Press the green check mark if these warnings appear. This will not affect calibration.

NOTE:

If the float was set heavier to complete the AHHC calibration procedure, adjust it to the recommended operating float after the calibration is complete.

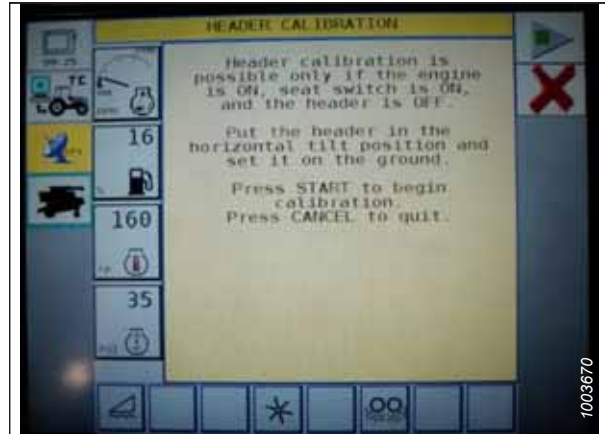

Figure 8.101: Challenger® Combine Display

Adjusting Header Height – Challenger® and Massey Ferguson®

The auto header height control (AHHC) feature allows the operator to set specific header heights.

DANGER

Ensure that all bystanders have cleared the area.

NOTE:

Changes may have been made to the combine controls or the display since this document was published. For the most up-to-date information, refer to the combine operator's manual.

Once the AHHC is activated, press and release the HEADER LOWER button on the control handle. The AHHC will automatically lower the header to the selected height setting.

You can adjust the selected AHHC height using HEIGHT ADJUSTMENT knob (A) on the control console. Turning the knob clockwise increases the selected height, and turning the knob counterclockwise decreases the selected height.



Figure 8.102: Height Adjustment Knob on the Combine Control Console

SETTING UP AUTO HEADER HEIGHT CONTROL SYSTEM

Adjusting Header Raise/Lower Rate – Challenger® and Massey Ferguson®

The rate at which the header rises and falls can be configured by accessing the HEADER CONTROL menu on the combine display.

NOTE:

Changes may have been made to the combine controls or the display since this document was published. For the most up-to-date information, refer to the combine operator's manual.

1. Select HEADER icon (A) on the FIELD page. The HEADER page appears.

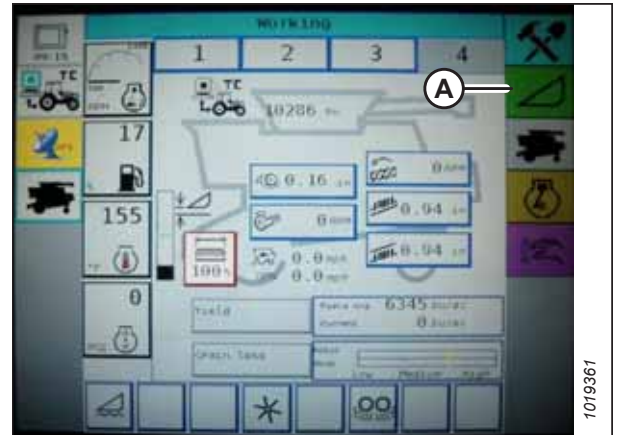

Figure 8.103: Challenger® Combine Display

2. Select HEADER CONTROL (A). The HEADER CONTROL page appears.

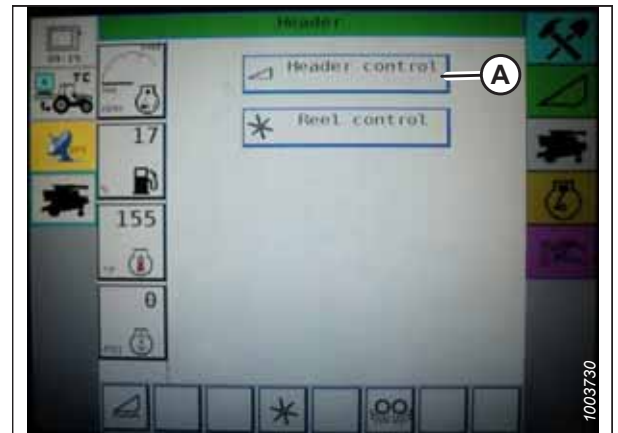

Figure 8.104: Challenger® Combine Display

SETTING UP AUTO HEADER HEIGHT CONTROL SYSTEM

3. Go to the TABLE SETTINGS tab.
4. Select the up arrow on MAX UP PWM to increase the percentage number and increase the raise speed. Select the down arrow on MAX UP PWM to decrease the percentage number and decrease the raise speed.
5. Select the up arrow on MAX DOWN PWM to increase the percentage number and increase the lower speed. Select the down arrow on MAX DOWN PWM to decrease the percentage number and decrease the lower speed.

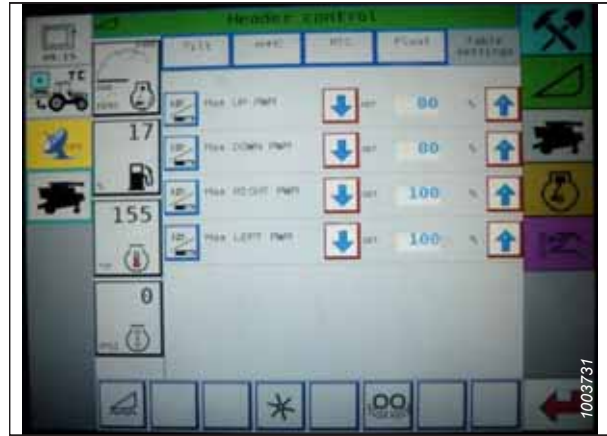

Figure 8.105: Challenger® Combine Display

Setting Auto Header Height Control Sensitivity – Challenger® and Massey Ferguson®

The sensitivity adjustment controls the distance that the cutterbar must travel before the auto header height control (AHC) raises or lowers the feeder house. When the sensitivity is set to maximum, only small changes in the ground height cause the AHC to move the feeder house. When the sensitivity is set to minimum, only large changes in the ground height cause the AHC to move the feeder house.

DANGER

Ensure that all bystanders have cleared the area.

NOTE:

Changes may have been made to the combine controls or the display since this document was published. For the most up-to-date information, refer to the combine operator's manual.

1. Select the HEADER icon on the FIELD page. The HEADER page appears.
2. Select HEADER CONTROL button (A). The HEADER CONTROL page appears. You can adjust the sensitivity on this page by using the up and down arrows.

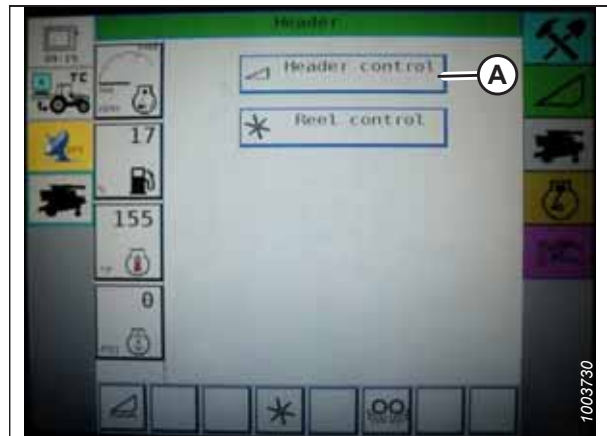

Figure 8.106: Challenger® Combine Display

SETTING UP AUTO HEADER HEIGHT CONTROL SYSTEM

3. Adjust the sensitivity to the maximum setting.
4. Activate the AHHC, and press the HEADER LOWER button on the control handle.
5. Decrease the sensitivity until the feeder house remains steady and does not bounce up and down.

NOTE:

This is the maximum sensitivity and it is only an initial setting. The final setting must be made in the field, as the system reaction will vary with changing surfaces and operating conditions.

NOTE:

If maximum sensitivity is not needed, a less sensitive setting will reduce the frequency of header height corrections and component wear. Partially opening the accumulator valve will cushion the action of the header lift cylinders and reduce header hunting.



Figure 8.107: Challenger® Combine Display

8.1.8 CLAAS Lexion 500 Series Combines

To make your header's auto header height control (AHHC) system compatible with the combine, configure the reel speed settings, set up the AHHC controls, and calibrate the AHHC system to ensure that it is working correctly.

Calibrating Auto Header Height Control – CLAAS Lexion 500 Series

The auto header height control (AHHC) sensor output must be calibrated for each combine.

DANGER

To prevent bodily injury or death from the unexpected start-up of the machine, always stop the engine and remove the key from the ignition before making adjustments to the machine.

DANGER

Ensure that all bystanders have cleared the area.

NOTE:

Changes may have been made to the combine controls or the display since this document was published. For the most up-to-date information, refer to the combine operator's manual.

NOTE:

If the header float is set too light, it can prevent the calibration of the AHHC. In order to prevent the header from separating from the float module, it may be necessary to change the float to a heavier setting during calibration.

SETTING UP AUTO HEADER HEIGHT CONTROL SYSTEM

1. Park the combine on a level surface.
2. Ensure that the header is level with the ground. If adjustment is required, refer to [10.5 Leveling Header, page 526](#).

NOTE:

Spirit level (A) is located on top of the float module frame. The header is level if the bubble is in the center of the spirit level.

3. Ensure that the center-link is set to **D**.

NOTE:

When calibration is complete, adjust the center-link back to the desired header angle. For instructions, refer to the header operator's manual.

4. Adjust the reel fore-aft position so that the indicator is at position **6**.
5. Position the header so that the cutterbar is 254–356 mm (10–14 in.) off the ground.
6. Shut down the engine, and remove the key from the ignition.

CAUTION

To prevent cuts, pinches, and other bodily harm to the person checking the down stops, ensure that nobody is manually lifting, bouncing, or moving the header in any way while the down stop washer is being touched and checked for movement.

7. Ensure that the float lock linkage is on the down stops (washer [A] cannot move) at both locations.

NOTE:

If the header is **NOT** on the down stops, the voltage may go out of range during operation and cause the AHHC system to malfunction. To fix the problem, make the header heavier by decreasing the float. For instructions, refer to [6.10 Checking and Adjusting Header Float, page 229](#).

8. Unlock the header float. For instructions, refer to the header operator's manual.

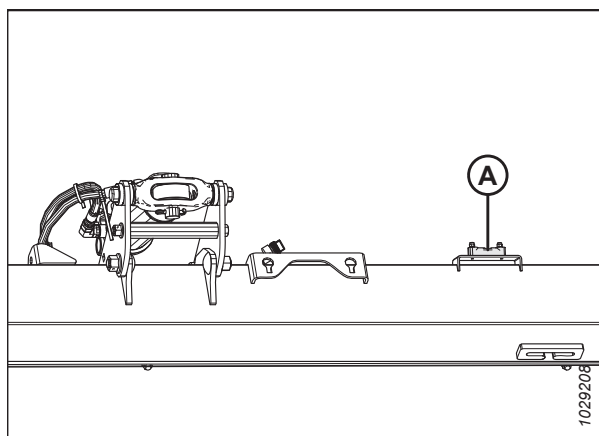

Figure 8.108: Spirit Level

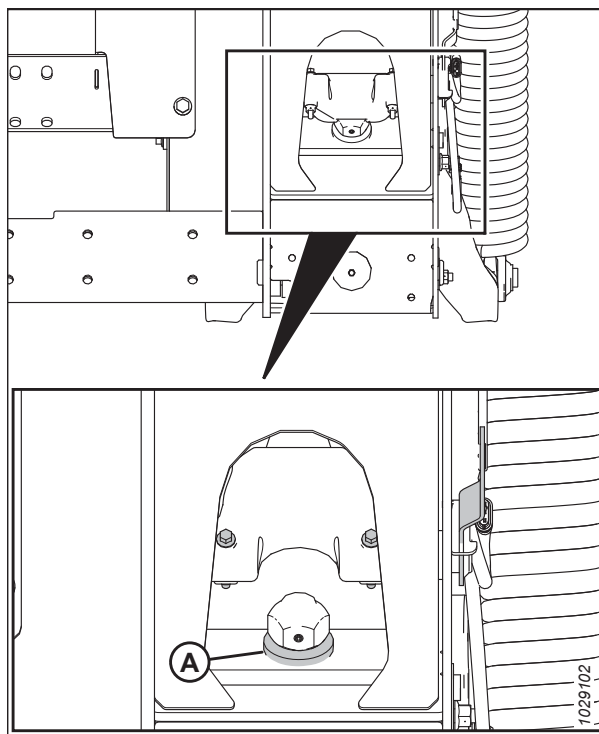

Figure 8.109: Down Stop Washer

SETTING UP AUTO HEADER HEIGHT CONTROL SYSTEM

- Press < key (A) or > key (B) to select AUTO HEADER, then press OK key (C). The E5 page indicates whether automatic header height is on or off.

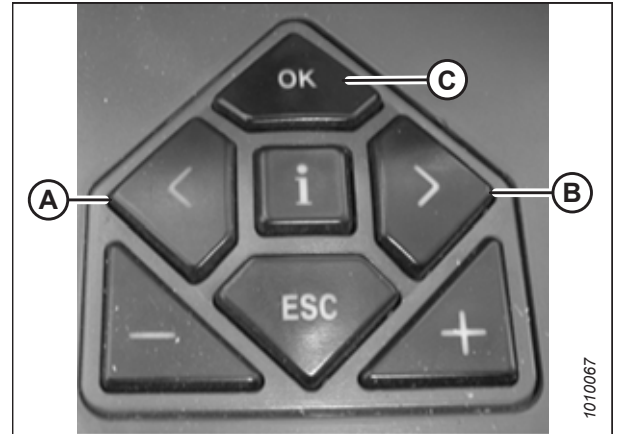

Figure 8.110: CLAAS Lexion Combine Controls

- Press – key (A) or + key (B) to turn the AHHC on, then press OK key (C).
- Engage the threshing mechanism and the header.

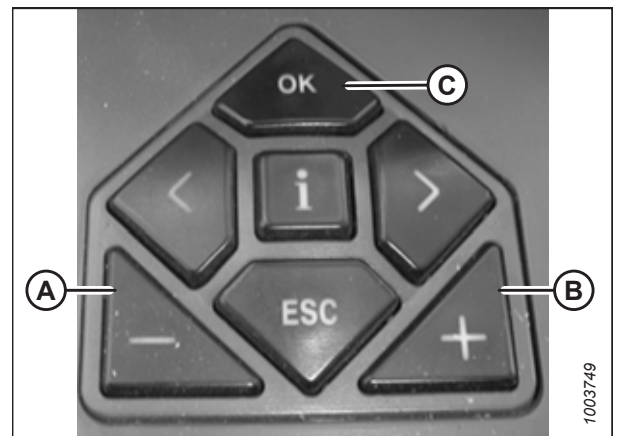

Figure 8.111: CLAAS Lexion Combine Controls

- Press the < or > key to select CUTT. HEIGHT LIMITS, then press the combine control's OK key.
- Follow the procedure displayed on the screen to program the upper and lower limits of the header into the CEBIS.

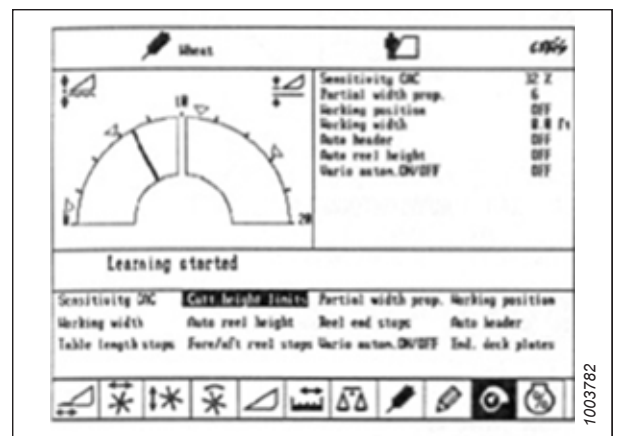

Figure 8.112: CLAAS Lexion Combine Display

SETTING UP AUTO HEADER HEIGHT CONTROL SYSTEM

14. Press the < or > key to select SENSITIVITY CAC, then press the combine control's OK key.

NOTE:

Setting the sensitivity of the AHHC system affects the reaction speed of the AHHC on the header.

15. Press the – key or the + key to change the reaction speed setting, then press the combine control's OK key.

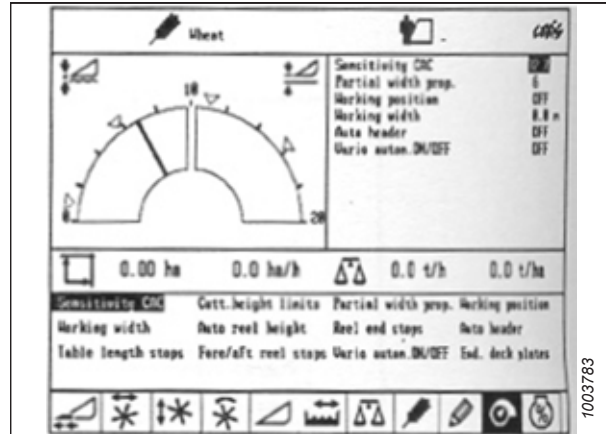

Figure 8.113: CLAAS Lexion Combine Display

16. Check the sensitivity setting by using line (A) or value (B).

NOTE:

The setting can be adjusted from 0–100%. When the sensitivity is 0%, the signals from the sensing bands have no effect on the automatic cutting height adjustment. When the sensitivity is 100%, the signals from the sensing bands have the maximum effect on the automatic cutting height adjustment. Adjust the sensitivity from 50%.

17. If the float was adjusted for the calibration procedure, check and adjust the float.

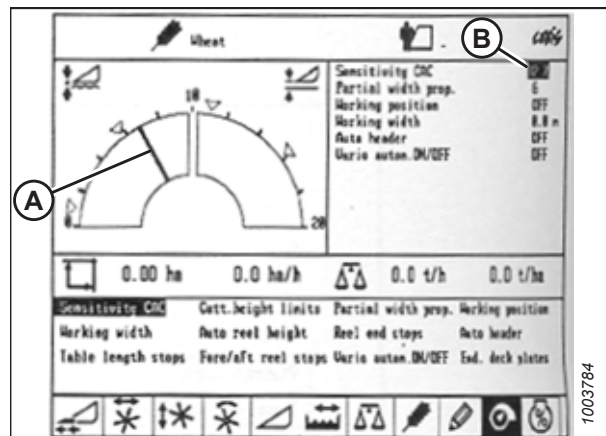

Figure 8.114: CLAAS Lexion Combine Display

Cutting Height – CLAAS Lexion 500 Series

Cutting heights can be programmed into the preset cutting height and auto contour systems. Use the preset cutting height system for cutting heights above 150 mm (6 in.), and use the auto contour system for cutting heights below 150 mm (6 in.).

Setting Preset Cutting Height – CLAAS Lexion 500 Series

Once the auto header height control (AHHC) system has been configured and activated, the preset cutting height can be configured.

NOTE:

Changes may have been made to the combine controls or the display since this document was published. For the most up-to-date information, refer to the combine operator's manual.

DANGER

Ensure that all bystanders have cleared the area.

1. Activate the machine enable switch.
2. Engage the threshing mechanism.
3. Engage the header.

SETTING UP AUTO HEADER HEIGHT CONTROL SYSTEM

4. Briefly press button (A) in order to activate the auto contour system, or briefly press button (B) in order to activate the preset cutting height system.

NOTE:

Button (A) is used only with AHHC function. Button (B) is used only with the return to cut function.



Figure 8.115: Control Handle Buttons

5. Press < key (C) or > key (D) to select the CUTTING HEIGHT page, then press OK key (E).
6. Press – key (A) or + key (B) to set the desired cutting height. An arrow indicates the selected cutting height on the scale.

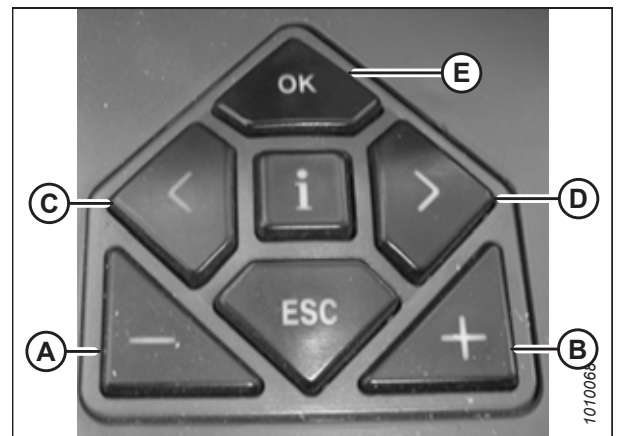

Figure 8.116: CLAAS Lexion Combine Controls

7. Briefly press button (A) or button (B) in order to select the set point.
8. Repeat Step 6, page 319 for the set point.



Figure 8.117: Control Handle Buttons

SETTING UP AUTO HEADER HEIGHT CONTROL SYSTEM

Setting Cutting Height Manually – CLAAS 500 Series

Once the auto header height control (AHHC) system has been configured and activated, the preset cutting height can be configured.

DANGER

Ensure that all bystanders have cleared the area.

NOTE:

Changes may have been made to the combine controls or the display since this document was published. For the most up-to-date information, refer to the combine operator's manual.

1. Press button (A) to raise the header, or button (B) to lower the header to the desired cutting height.
2. Press and hold button (C) for 3 seconds to program the cutting height (an alarm will sound after the new setting has been stored).
3. Program a second set point, if desired, by using button (A) to raise the header, or button (B) to lower the header to the desired cutting height, and briefly press button (C) to program the second set point (an alarm will sound after the new setting has been stored).

NOTE:

For above-the-ground cutting, repeat Step 1, page 320, then use **button (D)** instead of button (C) while repeating Step 2, page 320.



Figure 8.118: Control Handle Buttons

Setting Auto Header Height Control Sensitivity – CLAAS Lexion 500 Series

The sensitivity adjustment controls the distance the cutterbar must travel before the auto header height control (AHHC) moves the feeder house. When the sensitivity is set to maximum, only small changes in the ground height cause the system to move the feeder house. When the sensitivity is set to minimum, only large changes in the ground height cause the system to move the feeder house.

NOTE:

Set the upper and lower limits of the header before adjusting the sensitivity of the AHHC system. The setting can be adjusted from 0–100%. When the sensitivity is 0%, the signals from the sensing bands have no effect on adjusting the automatic cutting height. When the sensitivity is adjusted to 100%, the signals from the sensing bands have a maximum effect on adjusting the automatic cutting height. Start adjusting the sensitivity from 50%.

NOTE:

Changes may have been made to the combine controls or the display since this document was published. For the most up-to-date information, refer to the combine operator's manual.

SETTING UP AUTO HEADER HEIGHT CONTROL SYSTEM

1. Press < key (C) or > key (D) to select SENSITIVITY CAC, then press OK key (E).
2. Press – key (A) or + (B) key to change the reaction speed setting, then press OK key (E).

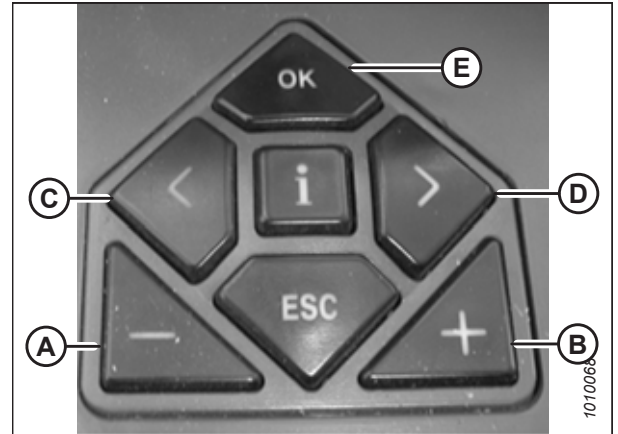

Figure 8.119: CLAAS Lexion Combine Controls

3. Check the sensitivity setting by using line (A) or value (B).

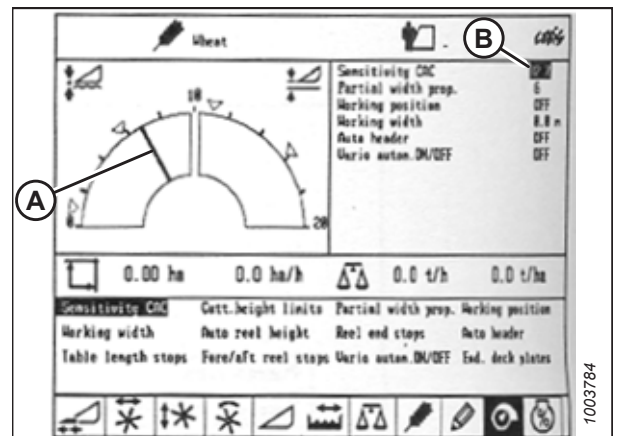
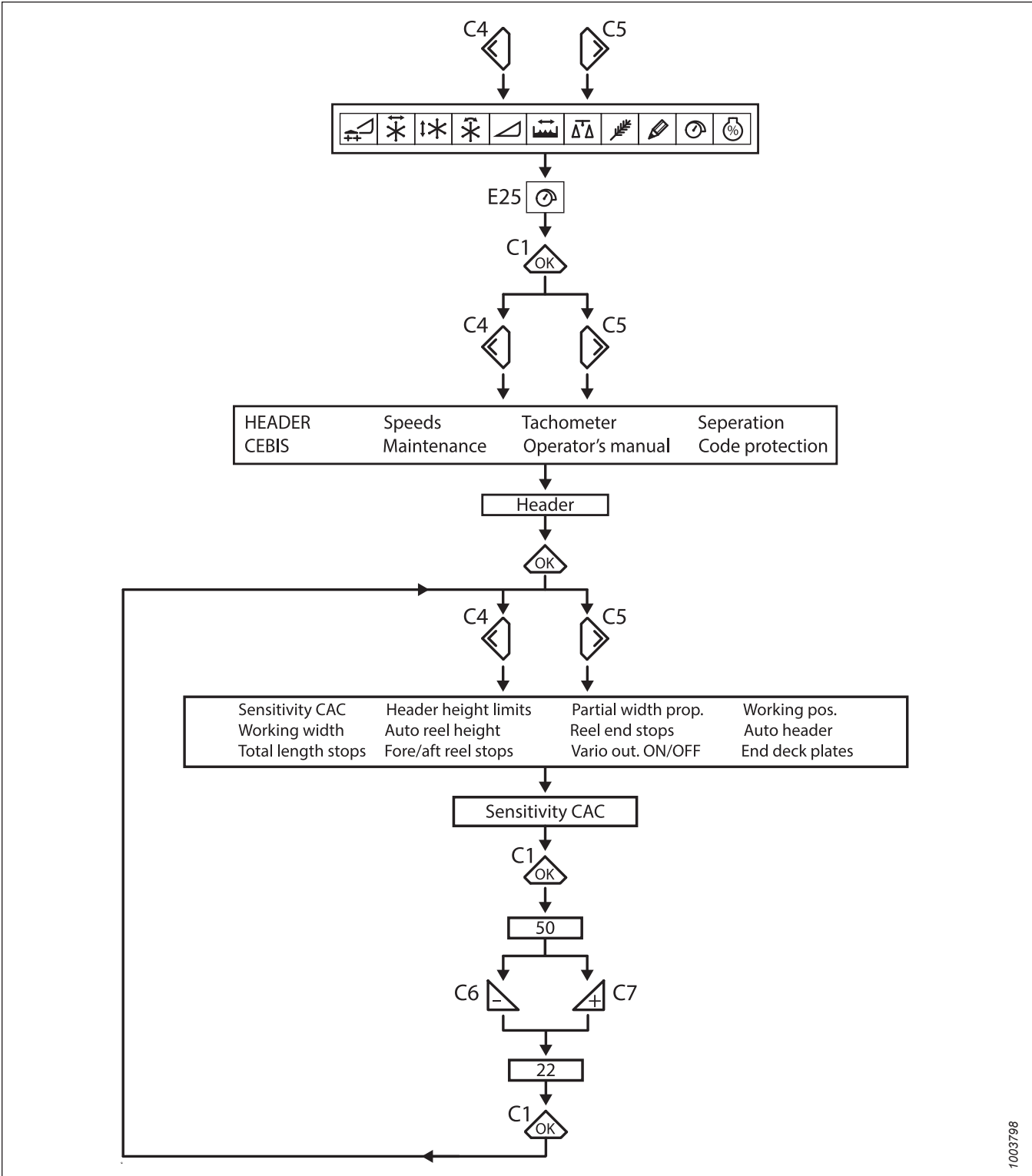

Figure 8.120: CLAAS Lexion Combine Display

SETTING UP AUTO HEADER HEIGHT CONTROL SYSTEM



1003798

Figure 8.121: Flow Chart for Setting the Sensitivity of the Float Optimizer

SETTING UP AUTO HEADER HEIGHT CONTROL SYSTEM

Adjusting Auto Reel Speed – CLAAS Lexion 500 Series

The preset reel speed can be set when the automatic header functions are activated.

NOTE:

Changes may have been made to the combine controls or the display since this document was published. For the most up-to-date information, refer to the combine operator's manual.

1. Press the < or > key to select REEL WINDOW. Window E15 displays the current advance or retard speed of the reel in relation to the ground speed.

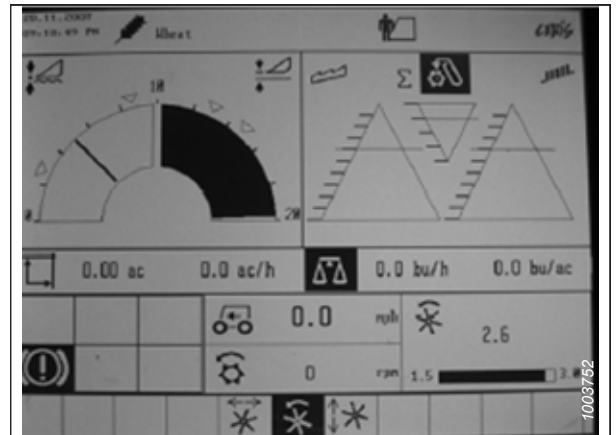

Figure 8.122: CLAAS Lexion Combine Display

2. Press OK key (C) to open the REEL SPEED window.
3. Press – key (A) or + key (B) to set the reel speed in relation to the current ground speed. Window E15 displays the selected reel speed.

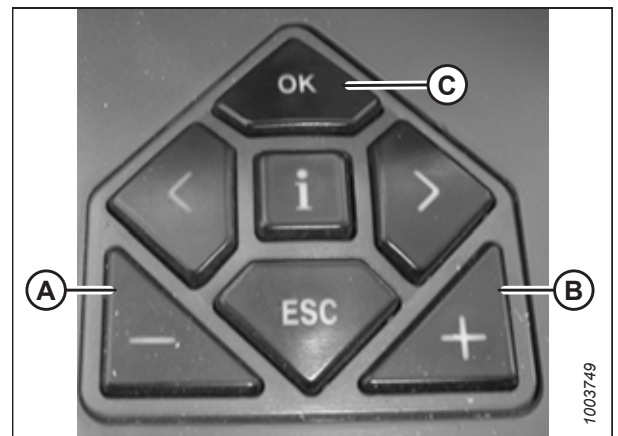

Figure 8.123: CLAAS Lexion Combine Controls

SETTING UP AUTO HEADER HEIGHT CONTROL SYSTEM

- Adjust the reel speed by rotating the rotary switch to reel position (A).
- Press the – or + key to set the reel speed.



Figure 8.124: CLAAS Lexion Combine Rotary Switch

- Press and hold button (A) or button (B) for 3 seconds to store the setting (an alarm sounds when the new setting has been stored).

NOTE:

Whenever button (A) or button (B) is pressed for 3 seconds, the current positions for reel speed and cutting height are stored.



Figure 8.125: CLAAS Lexion Control Handle Buttons

SETTING UP AUTO HEADER HEIGHT CONTROL SYSTEM

7. Press the < or > key to select REEL WINDOW. Window E15 displays the current advance or retard speed of the reel in relation to the ground speed.



Figure 8.126: CLAAS Lexion Combine Display

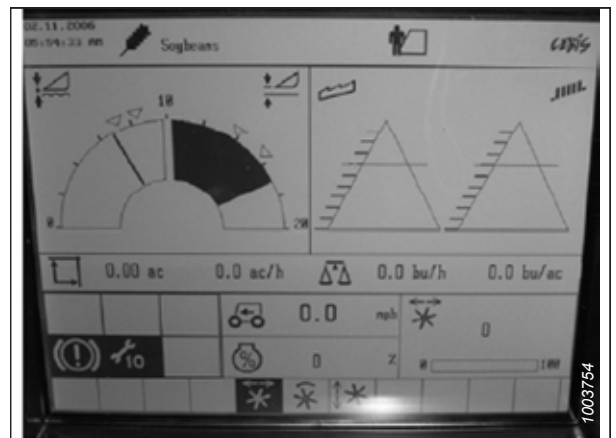

Figure 8.127: CLAAS Lexion Combine Display

8. Press OK key (E), then use < key (C) or > key (D) to select the REEL FORE AND AFT window.
9. Use – key (A) or + key (B) to set the reel fore-aft position.

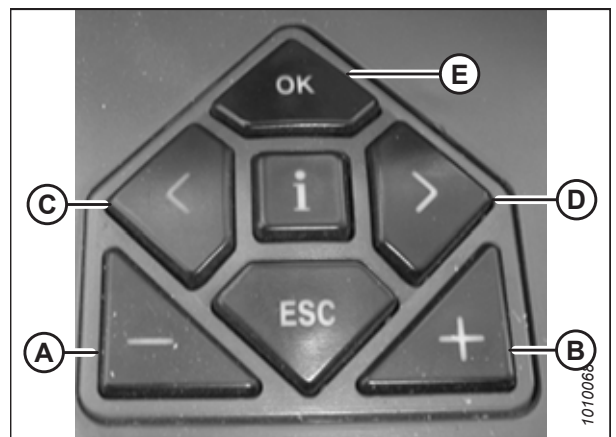

Figure 8.128: CLAAS Lexion Combine Controls

SETTING UP AUTO HEADER HEIGHT CONTROL SYSTEM

10. Press and hold button (A) or button (B) for 3 seconds to store the setting into the CEBIS (an alarm sounds when the new setting has been stored).

NOTE:

Whenever button (A) or button (B) is pressed for 3 seconds, the current positions for reel speed and cutting height are stored.



Figure 8.129: CLAAS Lexion Control Handle Buttons

8.1.9 CLAAS Lexion 600 and 700 Series Combines

To make your header's auto header height control (AHHC) system compatible with the combine, you must set your combine's header configuration options for the particular model of header, configure the reel speed settings, set up the AHHC controls, and calibrate the AHHC system to ensure that it is working correctly.

Calibrating Auto Header Height Control – CLAAS Lexion 600 and 700 Series

The auto header height control (AHHC) sensor output must be calibrated for each combine, or the AHHC feature will not work properly.

DANGER

To prevent bodily injury or death from the unexpected start-up of the machine, always stop the engine and remove the key from the ignition before making adjustments to the machine.

DANGER

Ensure that all bystanders have cleared the area.

NOTE:

Changes may have been made to the combine controls or the display since this document was published. For the most up-to-date information, refer to the combine operator's manual.

NOTE:

If the header float is set too light, it can prevent the calibration of the AHHC. In order to prevent the header from separating from the float module, it may be necessary to change the float to a heavier setting during calibration.

SETTING UP AUTO HEADER HEIGHT CONTROL SYSTEM

1. Park the combine on a level surface.
2. Ensure that the header is level with the ground. If adjustment is required, refer to [10.5 Leveling Header, page 526](#).

NOTE:

Spirit level (A) is located on top of the float module frame. The header is level if the bubble is in the center of the spirit level.

3. Ensure that the center-link is set to **D**.

NOTE:

When calibration is complete, adjust the center-link back to the desired header angle. For instructions, refer to the header operator's manual.

4. Adjust the reel fore-aft position so that the indicator is at position **6**.
5. Position the header so that the cutterbar is 254–356 mm (10–14 in.) off the ground.
6. Shut down the engine, and remove the key from the ignition.



CAUTION

To prevent cuts, pinches, and other bodily harm to the person checking the down stops, ensure that nobody is manually lifting, bouncing, or moving the header in any way while the down stop washer is being touched and checked for movement.

7. Ensure that the float lock linkage is on the down stops (washer [A] cannot move) at both locations.

NOTE:

If the header is **NOT** on the down stops, the voltage may go out of range during operation and cause the AHHC system to malfunction. To fix the problem, make the header heavier by decreasing the float. For instructions, refer to [6.10 Checking and Adjusting Header Float, page 229](#).

8. Unlock the header float. For instructions, refer to the header operator's manual.

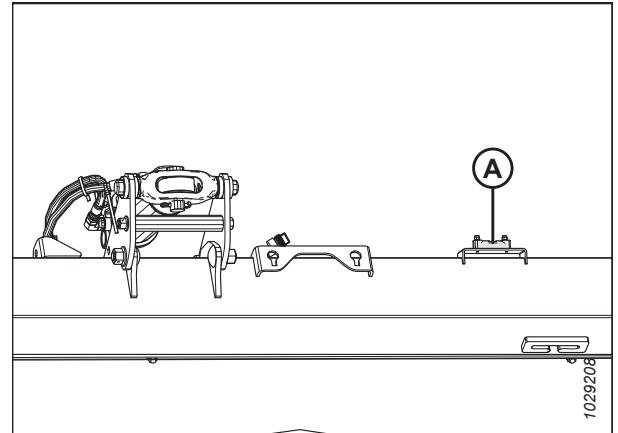

Figure 8.130: Spirit Level

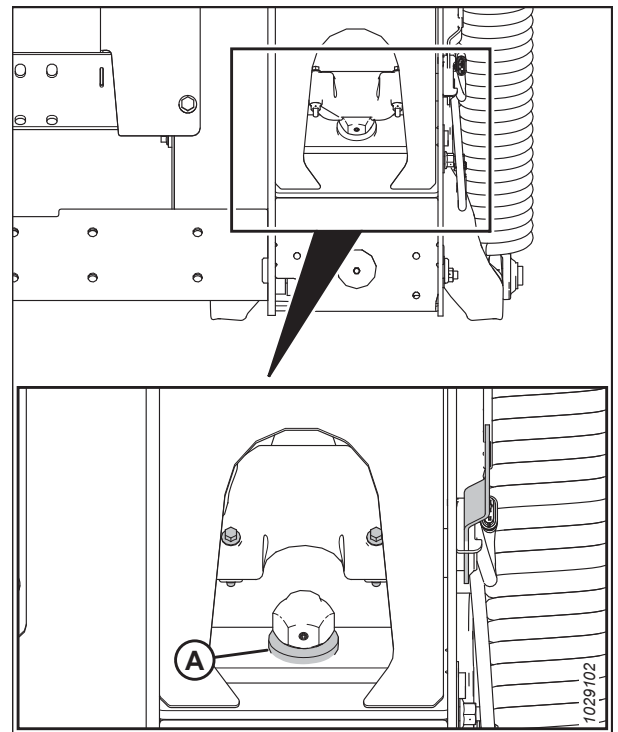

Figure 8.131: Down Stop Washer

SETTING UP AUTO HEADER HEIGHT CONTROL SYSTEM

- Use control knob (A) to highlight AUTO CONTOUR icon (B). Press control knob (A) to select it.



Figure 8.132: CLAAS Lexion Combine Display, Console, and Control Handle

- Use control knob (A) to highlight the icon resembling a header with up and down arrows (not shown). Press control knob (A) to select it. Highlighted header icon (B) will appear on the screen.



Figure 8.133: CLAAS Lexion Combine Display, Console, and Control Handle

- Use control knob (A) to highlight header icon (B). Press control knob (A) to select it.



Figure 8.134: CLAAS Lexion Combine Display, Console, and Control Handle

SETTING UP AUTO HEADER HEIGHT CONTROL SYSTEM

12. Use control knob (A) to highlight screwdriver icon (B).
13. Engage the combine separator and feeder house.
14. Press control knob (A). A progress bar appears.



Figure 8.135: CLAAS Lexion Combine Display, Console, and Control Handle

15. Fully raise the feeder house. Progress bar (A) advances to 25%.
16. Fully lower the feeder house. Progress bar (A) advances to 50%.
17. Fully raise the feeder house. Progress bar (A) advances to 75%.
18. Fully lower the feeder house. Progress bar (A) advances to 100%.



Figure 8.136: CLAAS Lexion Combine Display, Console, and Control Handle

19. Ensure that progress bar (A) is at 100%. The calibration procedure is now complete.

NOTE:

If the voltage is not within the range of 0.7–4.3 V at any time throughout the calibration process, the monitor will indicate that the learning procedure has not concluded.

20. If the float was adjusted for the calibration procedure, check and adjust the float.



Figure 8.137: CLAAS Lexion Combine Display, Console, and Control Handle

SETTING UP AUTO HEADER HEIGHT CONTROL SYSTEM

Setting Cutting Height – CLAAS Lexion 600 and 700 Series

The Operator can configure two different cutting height presets. The height presets can be selected using the combine's control handle.

DANGER

Ensure that all bystanders have cleared the area.

NOTE:

Changes may have been made to the combine controls or the display since this document was published. For the most up-to-date information, refer to the combine operator's manual.

1. Lower the header to the desired cutting height or to the ground pressure setting. The float indicator box should be set to 1.5.
2. Hold the left side of switch (A) until you hear a ping sound.



Figure 8.138: CLAAS Lexion Combine Display, Console, and Control Handle

Setting Auto Header Height Control Sensitivity – CLAAS Lexion 600 and 700 Series

The sensitivity adjustment controls the distance that the cutterbar must travel before the auto header height control (AHHC) moves the feeder house. When the sensitivity is set to maximum, only small changes in the ground height cause the feeder house to move. When the sensitivity is set to minimum, only large changes in the ground height cause the feeder house to move.

NOTE:

Changes may have been made to the combine controls or the display since this document was published. For the most up-to-date information, refer to the combine operator's manual.

SETTING UP AUTO HEADER HEIGHT CONTROL SYSTEM

1. Use control knob (A) to highlight HEADER/REEL icon (B). Press control knob (A) to select it. The HEADER/REEL dialog box opens.
2. Select the HEADER icon.

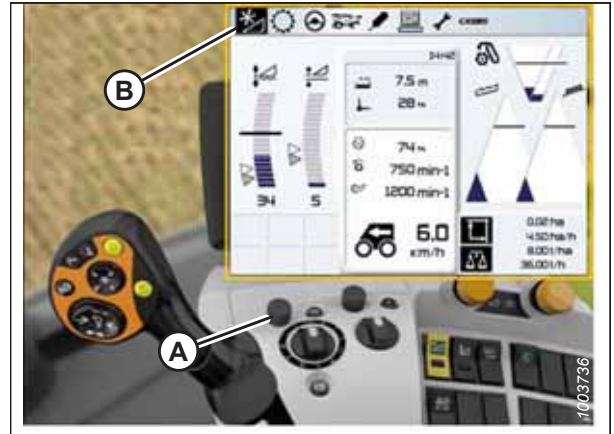

Figure 8.139: CLAAS Lexion Combine Display, Console, and Control Handle

3. Select FRONT ATTACHMENT PARAMETER SETTINGS icon (A). A list of settings appears.
4. Select SENSITIVITY CAC (B) from the list.



Figure 8.140: CLAAS Lexion Combine Display, Console, and Control Handle

5. Select SENSITIVITY CAC icon (A).
6. If the reaction time between the header and the float module is too slow while cutting on the ground, increase CUTTING HEIGHT ADJUSTMENT setting (B). If the reaction time between the header and the float module is too fast, decrease the CUTTING HEIGHT ADJUSTMENT setting.

NOTE:

The settings from 1–50 provide a faster response, whereas the settings from -1 to -50 provide a slower response. For the best results, make adjustments in increments of 5.

7. If the header lowers too slowly, increase the sensitivity. If the header hits the ground too hard or lowers too quickly, decrease the sensitivity.



Figure 8.141: CLAAS Lexion Combine Display

SETTING UP AUTO HEADER HEIGHT CONTROL SYSTEM

Adjusting Auto Reel Speed – CLAAS Lexion 600 and 700 Series

You can set the preset reel speed after activating the automatic header functions.

NOTE:

Changes may have been made to the combine controls or the display since this document was published. For the most up-to-date information, refer to the combine operator's manual.

1. Use control knob (A) to highlight HEADER/REEL icon (B). Press control knob (A) to select it. The HEADER/REEL dialog box appears.

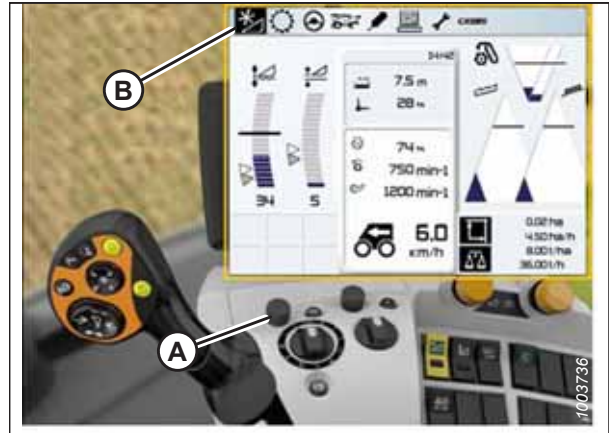

Figure 8.142: CLAAS Lexion Combine Display, Console, and Control Handle

2. Use control knob (A) to select REEL SPEED (B), and adjust the reel speed (if you are **NOT** using Auto Reel Speed). A graph appears in the dialog box.



Figure 8.143: CLAAS Lexion Combine Display, Console, and Control Handle

SETTING UP AUTO HEADER HEIGHT CONTROL SYSTEM

3. Select ACTUAL VALUE (A) from the AUTO REEL SPEED dialog box (if you are using Auto Reel Speed). The ACTUAL VALUE dialog box indicates the auto reel speed.



Figure 8.144: CLAAS Lexion Combine Display, Console, and Control Handle

4. Use control knob (A) to adjust the reel speed.

NOTE:

This option is only available with the engine at full throttle.



Figure 8.145: CLAAS Lexion Combine Display, Console, and Control Handle

Calibrating Reel Height Sensor and Reel Fore-Aft Sensor – CLAAS Lexion 600 and 700 Series

The auto header height control (AHHC) sensor output must be calibrated for each combine, or the AHHC feature will not work properly.

NOTE:

Changes may have been made to the combine controls or the display since this document was published. For the most up-to-date information, refer to the combine operator's manual.

NOTE:

If the header float is set too light, it can prevent the calibration of the AHHC. You may need to set the float heavier for the calibration procedure so the header does not separate from the float module.

SETTING UP AUTO HEADER HEIGHT CONTROL SYSTEM

NOTE:

Calibrating the reel fore-aft sensor is only possible if the header is integration-equipped. If the float module is equipped with connector (A) next to multicoupler (B), the header is **NOT** integration-equipped.

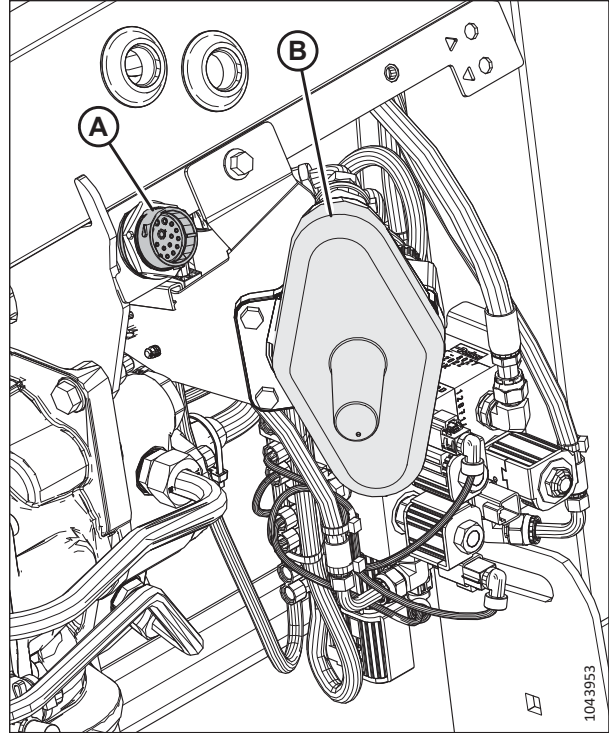

Figure 8.146: Integration Module Installed on Multicoupler

DANGER

Ensure that all bystanders have cleared the area.

1. Ensure that the center-link is set to **D**.

NOTE:

When calibration is complete, adjust the center-link back to the desired header angle. For instructions, refer to the header operator's manual.

2. Start the engine.
3. Position the header 254–356 mm (10–14 in.) off the ground. Keep the engine running.

IMPORTANT:

Do **NOT** turn off the engine. The combine has to be at full throttle for the sensors to calibrate properly.

SETTING UP AUTO HEADER HEIGHT CONTROL SYSTEM

4. Use control knob (A) to highlight FRONT ATTACHMENT icon (B). Press control knob (A) to select it.



Figure 8.147: CLAAS Lexion Combine Display, Console, and Control Handle

5. Use control knob (A) to highlight REEL icon (B). Press control knob (A) to select it.

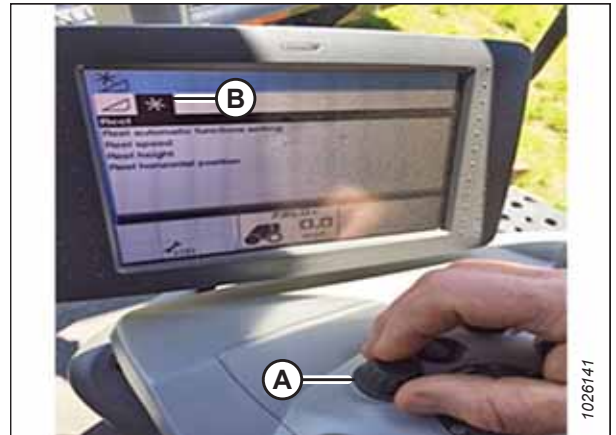

Figure 8.148: CLAAS Lexion Combine Display and Console

6. Highlight REEL HEIGHT icon (A). Press the control knob to select it.
7. Select LEARNING END STOPS (B) from the list.



Figure 8.149: CLAAS Lexion Combine Display and Console

SETTING UP AUTO HEADER HEIGHT CONTROL SYSTEM

- Use control knob (A) to highlight screwdriver icon (B).
- Press the control knob.



Figure 8.150: CLAAS Lexion Combine Display, Console, and Control Handle

- Progress bar chart (A) appears on the screen.
- Follow the prompts on the screen to raise and lower the reel.



Figure 8.151: CLAAS Lexion Combine Display, Console, and Control Handle

- Ensure that progress bar chart (A) displays 100%. When the progress bar chart displays 100%, the calibration procedure is complete.



Figure 8.152: CLAAS Lexion Combine Display, Console, and Control Handle

SETTING UP AUTO HEADER HEIGHT CONTROL SYSTEM

13. **If header is integration-equipped:** Calibrate the reel fore-aft sensor by selecting REEL HORIZONTAL POSITION (A), then LEARNING END STOPS (B).
14. Repeat Step 8, page 336 to Step 12, page 336.



Figure 8.153: CLAAS Lexion Combine Display and Console

Adjusting Auto Reel Height – CLAAS Lexion 600 and 700 Series

The auto reel height setting can be configured by accessing the REEL menu on the combine display.

NOTE:

Changes may have been made to the combine controls or the display since this document was published. For the most up-to-date information, refer to the combine operator's manual.

1. Use HOTKEY rotary dial (A) to select REEL icon (B).

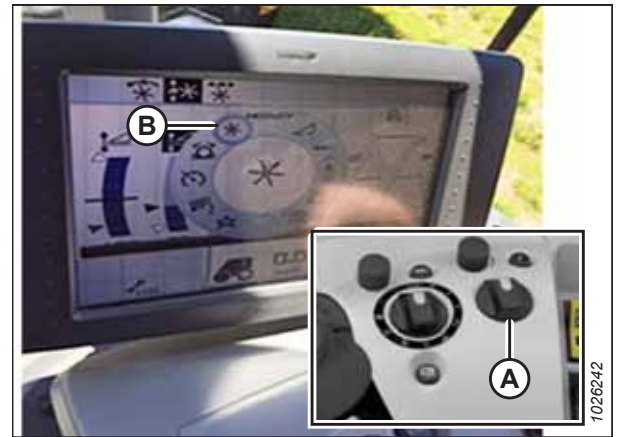

Figure 8.154: CLAAS Lexion Combine Display and Console

SETTING UP AUTO HEADER HEIGHT CONTROL SYSTEM

- Use control knob (A) to select AUTO REEL HEIGHT icon (B) at the top of the page.

NOTE:

AUTO REEL HEIGHT icon (C) at the center of the page should be highlighted black. If it is not black, either the end stops have not been set or the auto header height control (AHHC) is not active. For instructions, refer to *Calibrating Reel Height Sensor and Reel Fore-Aft Sensor – CLAAS Lexion 600 and 700 Series, page 333*.

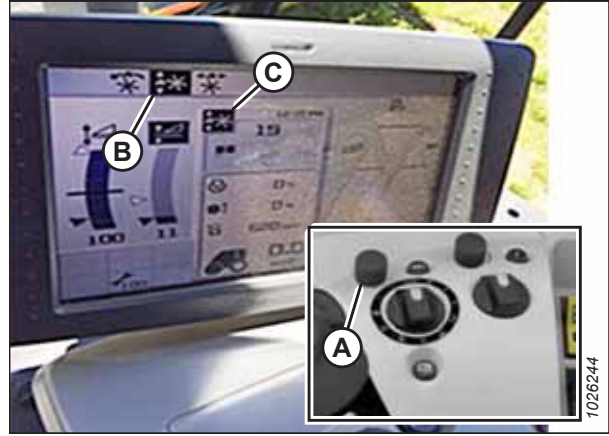

Figure 8.155: CLAAS Lexion Combine Display and Console

- Adjust the auto reel height position for the current AHHC position using outer scroll knob (A). To lower the preset reel position, turn the scroll knob counterclockwise; to raise the preset reel position, turn the scroll knob clockwise. The display will update current setting (B).

NOTE:

If the AUTO REEL HEIGHT icon in the center of the page is not black, an AHHC position is not currently active.

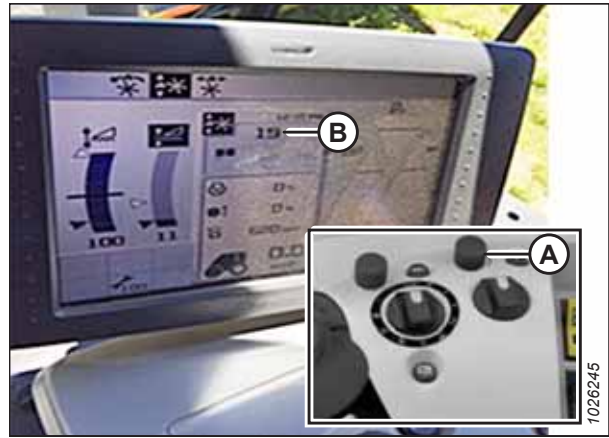

Figure 8.156: CLAAS Lexion Combine Display and Console

8.1.10 CLAAS Lexion 5/6/7/8000 Series and TRION Series Combines

To make your header's auto header height control (AHHC) system compatible with the combine, you must set your combine's header configuration options for the particular model of header, configure the reel speed settings, set up the AHHC controls, and calibrate the AHHC system to ensure that it is working correctly.

Header Settings Quick Reference – CLAAS Lexion 5/6/7/8000 Series and TRION Series

The recommended auto header height control (AHHC) settings for a D2 Series Draper Header operating with a CLAAS Lexion 5/6/7/8000 Series or TRION Series combine are provided.

Table 8.5 Header Settings – CLAAS Lexion 5/6/7/8000 Series and TRION Series

Setup Parameter	Suggested Setting
Front attachment type	Draper product by other manufacturer
Working width	Set header width
Drop rate with auto contour	Adjust to preference
Reel speed adjust	Adjust to preference

SETTING UP AUTO HEADER HEIGHT CONTROL SYSTEM

Setting up Header – CLAAS Lexion 5/6/7/8000 Series and TRION Series

To set up a header to work with the auto header height control (AHHC) system, you will need to access the FRONT ATTACHMENT menu using the CEBIS terminal.

NOTE:

Changes may have been made to the combine controls or the display since this document was published. For the most up-to-date information, refer to the combine operator's manual.

1. From the main page, select FRONT ATTACHMENT (A).



Figure 8.157: CEBIS Main Page

2. From the drop down list, select FRONT ATTACHMENT PARAMETERS (A).



Figure 8.158: Front Attachment Page

SETTING UP AUTO HEADER HEIGHT CONTROL SYSTEM

3. From the FRONT ATTACHMENT PARAMETERS page, select FRONT ATTACHMENT TYPE (A).
4. From the drop down list, select DRAPER PRODUCT BY OTHER MANUFACTURER (B).



Figure 8.159: Attachment Parameters Page

5. From the FRONT ATTACHMENT PARAMETERS page, select WORKING WIDTH (A).
6. Set the header width by sliding adjuster arrow (B) up or down.
7. Select check mark (C) to save the settings.



Figure 8.160: Attachment Parameters Page

Calibrating Auto Header Height Control – CLAAS Lexion 5/6/7/8000 Series and TRION Series

The auto header height control (AHC) sensor output must be calibrated for each combine, or the AHC feature will not work properly.

! DANGER

To prevent bodily injury or death from the unexpected start-up of the machine, always stop the engine and remove the key from the ignition before making adjustments to the machine.

! DANGER

Ensure that all bystanders have cleared the area.

NOTE:

Changes may have been made to the combine controls or the display since this document was published. For the most up-to-date information, refer to the combine operator's manual.

NOTE:

If the header float is set too light, it can prevent the calibration of the AHC. In order to prevent the header from separating from the float module, it may be necessary to change the float to a heavier setting during calibration.

SETTING UP AUTO HEADER HEIGHT CONTROL SYSTEM

1. Park the combine on a level surface.
2. Lower the header fully.
3. Shut down the engine, and remove the key from the ignition.
4. Ensure that the header is level with the ground. If adjustment is required, refer to [10.5 Leveling Header, page 526](#).

NOTE:

Spirit level (A) is located on top of the float module frame. The header is level if the bubble is in the center of the spirit level.

5. Ensure that the center-link is set to **D**.

NOTE:

When calibration is complete, adjust the center-link back to the desired header angle. For instructions, refer to the header operator's manual.

6. Adjust the reel fore-aft position so that the indicator is at position **6**.
7. Position the header so that the cutterbar is 254–356 mm (10–14 in.) off the ground.
8. Shut down the engine, and remove the key from the ignition.



CAUTION

To prevent cuts, pinches, and other bodily harm to the person checking the down stops, ensure that nobody is manually lifting, bouncing, or moving the header in any way while the down stop washer is being touched and checked for movement.

9. Ensure that the float lock linkage is on the down stops (washer [A] cannot move) at both locations.

NOTE:

If the header is **NOT** on the down stops, the voltage may go out of range during operation and cause the AHHC system to malfunction. To fix the problem, make the header heavier by decreasing the float. For instructions, refer to [6.10 Checking and Adjusting Header Float, page 229](#).

10. Unlock the header float. For instructions, refer to the header operator's manual.

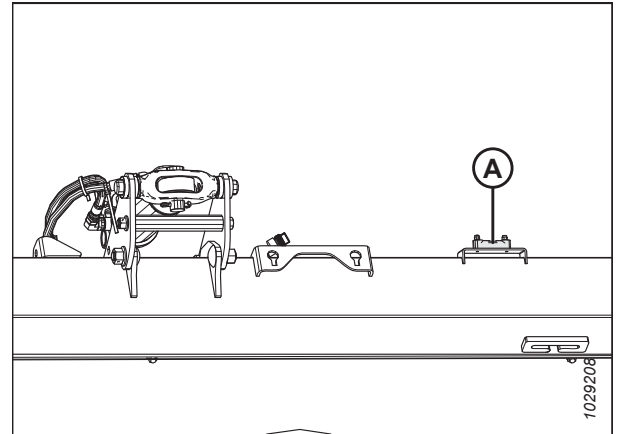

Figure 8.161: Spirit Level

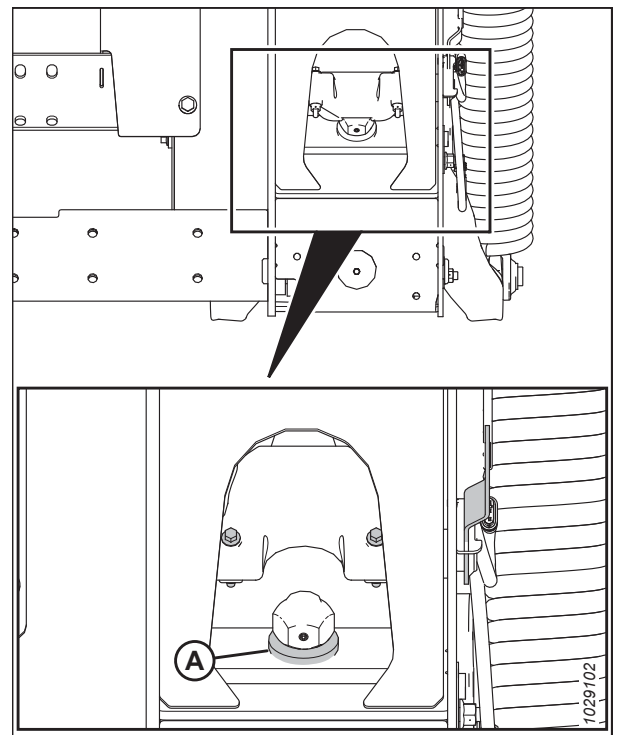

Figure 8.162: Down Stop Washer

SETTING UP AUTO HEADER HEIGHT CONTROL SYSTEM

11. From the MAIN page, select FRONT ATTACHMENT (A).



Figure 8.163: CEBIS Main Page

12. Select LEARNING PROCEDURES (A) from the menu.

13. Select FRONT ATTACHMENT HEIGHT (B).

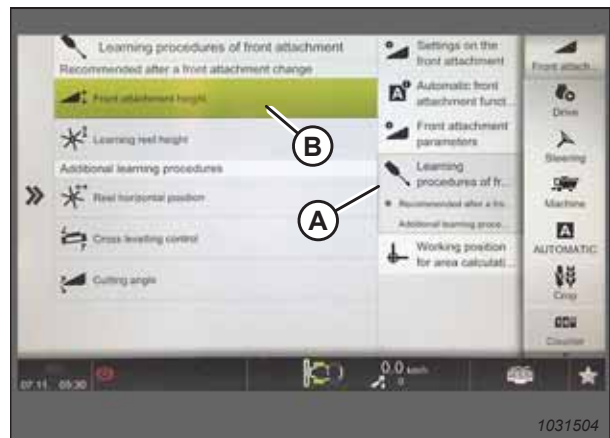

Figure 8.164: Learning Procedures Page

14. Follow the prompts that appear in DESCRIPTION and NOTES fields (A).

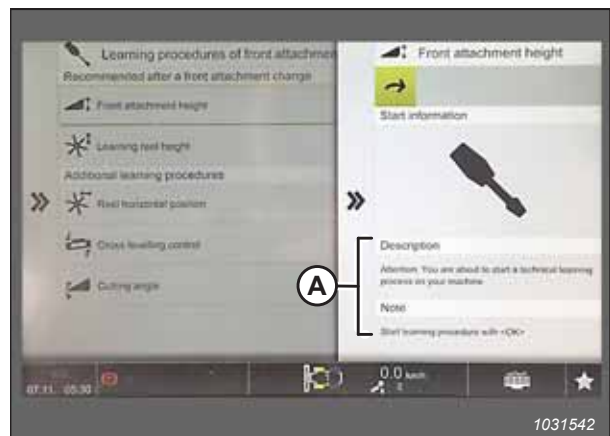

Figure 8.165: Front Attachment Height Page

SETTING UP AUTO HEADER HEIGHT CONTROL SYSTEM

15. When prompted, press OK button (A) to start the learning procedure.



Figure 8.166: Operator Controls

16. When prompted, raise the front attachment with button (A) on the multifunction lever.
17. When prompted, lower the front attachment with button (B) on the multifunction lever.
18. Repeat Steps 16, page 343 and 17, page 343 until calibration is complete.



Figure 8.167: Multifunction Lever

Setting Cut and Reel Height Preset – CLAAS Lexion 5/6/7/8000 Series and TRION Series

The reel and cut height setting can be stored in the combine. When harvesting, select the setting from the control handle.

DANGER

Ensure that all bystanders have cleared the area.

NOTE:

Changes may have been made to the combine controls or the display since this document was published. For the most up-to-date information, refer to the combine operator's manual.

SETTING UP AUTO HEADER HEIGHT CONTROL SYSTEM

1. Set the desired cutting height with feeder house raise/lower buttons (A) on the multifunction lever.
2. Set the desired reel position with buttons (B).
3. Press and hold AUTO HEIGHT PRESET button (C) to store the settings.



Figure 8.168: Multifunction Lever

NOTE:

Triangle (A) appears on the header height gauge indicating the preset level.



Figure 8.169: CEBIS Main Page

Setting Auto Header Height Control Sensitivity – CLAAS Lexion 5/6/7/8000 Series and TRION Series

The sensitivity adjustment controls the distance the cutterbar must travel before the auto header height control (AHHC) moves the feeder house. When the sensitivity is set to maximum, only small changes in ground height are needed to cause the system to move the feeder house. When the sensitivity is set to minimum, only large changes in the ground height cause the system to move the feeder house.

DANGER

Ensure that all bystanders have cleared the area.

NOTE:

Changes may have been made to the combine controls or the display since this document was published. For the most up-to-date information, refer to the combine operator's manual.

SETTING UP AUTO HEADER HEIGHT CONTROL SYSTEM

1. From the main page, select FRONT ATTACHMENT (A).



Figure 8.170: CEBIS Main Page

2. From the drop down list, select FRONT ATTACHMENT PARAMETERS (A).



Figure 8.171: Front Attachment Parameters Page

3. Scroll through the list and select DROP RATE WITH AUTO CONTOUR icon (A).
4. Adjust the drop rate by sliding adjuster arrow (B) up or down.
5. Select check mark (C) to confirm the settings.



Figure 8.172: Drop Rate with Auto Contour Page

SETTING UP AUTO HEADER HEIGHT CONTROL SYSTEM

Adjusting Auto Reel Speed – CLAAS Lexion 5/6/7/8000 Series and TRION Series

The preset reel speed can be set after activating the automatic header functions.

DANGER

Ensure that all bystanders have cleared the area.

NOTE:

Changes may have been made to the combine controls or the display since this document was published. For the most up-to-date information, refer to the combine operator's manual.

1. From the main page, select FRONT ATTACHMENT (A).



Figure 8.173: CEBIS Main Page

2. From the list, select SETTINGS ON FRONT ATTACHMENT (A).
3. Select REEL TARGET VALUES (B).
4. Select REEL SPEED ADJUST icon (C).



Figure 8.174: Settings on Front Attachment Page

SETTING UP AUTO HEADER HEIGHT CONTROL SYSTEM

5. Adjust the reel speed target value by sliding adjuster arrow (A) up or down.
6. Select check mark (B) to save the setting.



Figure 8.175: Reel Speed Target Value Page

Calibrating Reel Height Sensor and Reel Fore-Aft Sensor – CLAAS Lexion 5/6/7/8000 Series and TRION Series

The auto header height control (AHC) sensor output must be calibrated for each combine, or the reel position feature will not work properly.

DANGER

Ensure that all bystanders have cleared the area.

NOTE:

Changes may have been made to the combine controls or the display since this document was published. For the most up-to-date information, refer to the combine operator's manual.

SETTING UP AUTO HEADER HEIGHT CONTROL SYSTEM

NOTE:

Calibrating the reel fore-aft sensor is only possible if the header is integration-equipped. If the float module is equipped with connector (A) next to multicoupler (B), the header is **NOT** integration-equipped.

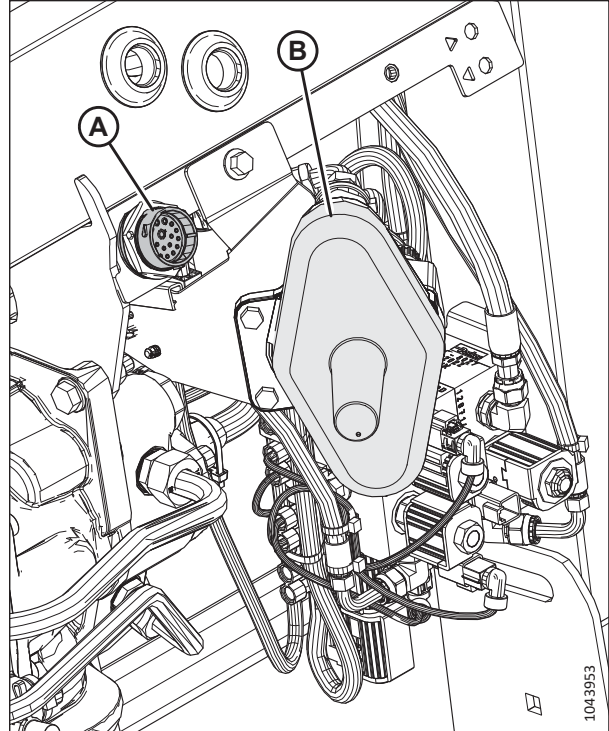

Figure 8.176: Integration Module Installed on Multicoupler

1. Park the combine on a level surface.
2. Position the header so that the cutterbar is 254–356 mm (10–14 in.) off the ground.

NOTE:

Do **NOT** turn off the engine. The combine has to be at full idle for the sensors to calibrate properly.

3. From the main page, select FRONT ATTACHMENT (A).



Figure 8.177: CEBIS Main Page

SETTING UP AUTO HEADER HEIGHT CONTROL SYSTEM

4. Select LEARNING PROCEDURES FOR FRONT ATTACHMENT (A).
5. Select LEARNING REEL HEIGHT (B).

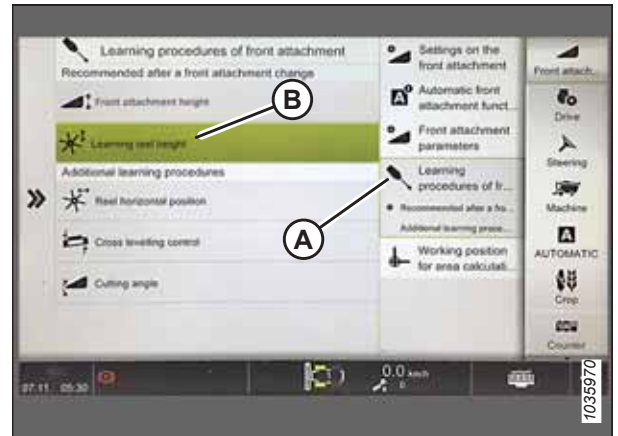

Figure 8.178: Front Attachment Page

6. Follow the prompts that appear in DESCRIPTION and NOTES fields (A).

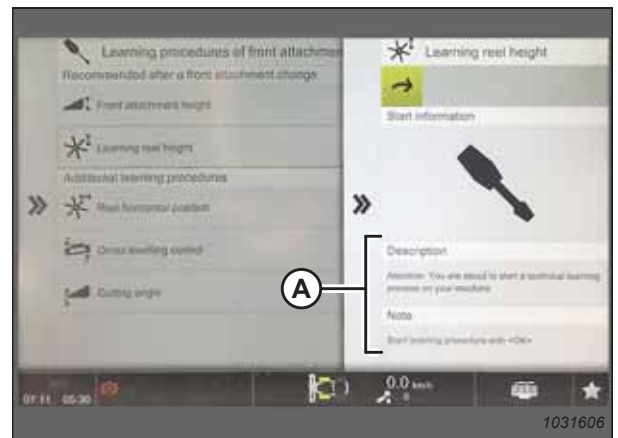

Figure 8.179: Learning Reel Height Page

SETTING UP AUTO HEADER HEIGHT CONTROL SYSTEM

- When prompted, select OK button (A) to start the learning procedure.



Figure 8.180: Operator Controls

- If the header is integration-equipped:** Calibrate the reel fore-aft sensor by selecting REEL HORIZONTAL POSITION (A) as the learning procedure and follow the prompts on the screen.

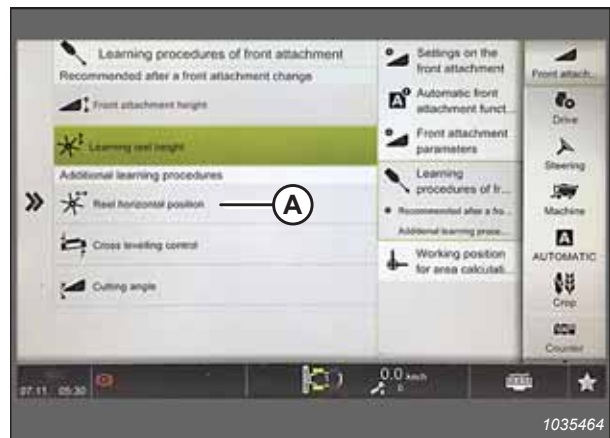

Figure 8.181: Front Attachment Page

8.1.11 Gleaner® R65, R66, R75, R76, and S Series Combines

To make your header's auto header height control (AHHC) system compatible with the combine, configure the reel speed settings, set up the AHHC controls, and calibrate the AHHC system to ensure that it is working correctly.

Checking Voltage Range from Combine Cab – Gleaner® R65, R66, R75, R76, and Pre-2016 S Series

The auto header height control (AHHC) sensor needs to operate in a specific voltage range in order to work properly.

NOTE:

Changes may have been made to the combine controls or the display since this document was published. For the most up-to-date information, refer to the combine operator's manual.

⚠ DANGER

To prevent bodily injury or death from the unexpected start-up of the machine, always stop the engine and remove the key from the ignition before making adjustments to the machine.

⚠ DANGER

Ensure that all bystanders have cleared the area.

1. Position the header so that the cutterbar is 254–356 mm (10–14 in.) off the ground.
2. Shut down the engine, and remove the key from the ignition.
3. Unlock the header float. For instructions, refer to the header operator's manual.

⚠ CAUTION

To prevent cuts, pinches, and other bodily harm to the person checking the down stops, ensure that nobody is manually lifting, bouncing, or moving the header in any way while the down stop washer is being touched and checked for movement.

4. Ensure that the float lock linkage is on the down stops (washer [A] cannot move) at both locations.

NOTE:

If the header is **NOT** on the down stops, the voltage may go out of range during operation and cause the AHHC system to malfunction. To fix the problem, make the header heavier by decreasing the float. For instructions, refer to [6.10 Checking and Adjusting Header Float, page 229](#).

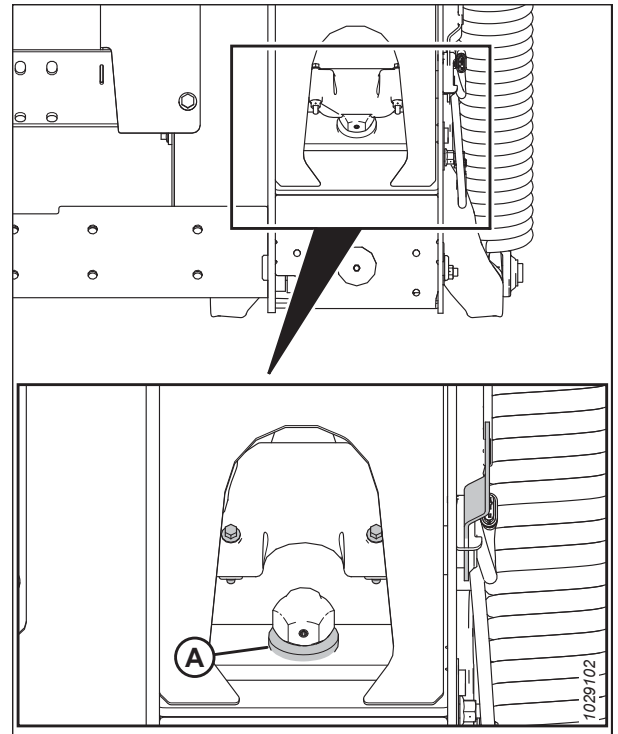

Figure 8.182: Down Stop Washer

5. If the pointer is not on zero, loosen bolt (A) and slide float indicator plate (B) until pointer (C) is on 0 (D). Tighten the nut on bolt (A).

NOTE:

Use zero dot (E) above the decal to correctly set the indicator needle.

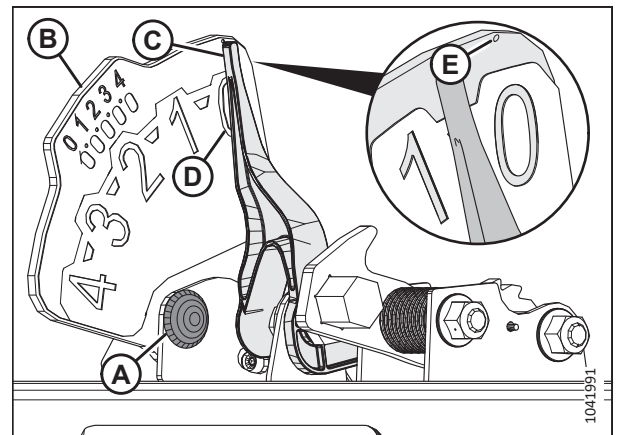

Figure 8.183: Float Indicator

SETTING UP AUTO HEADER HEIGHT CONTROL SYSTEM



Figure 8.184: Combine Heads-Up Display

6. Ensure that the header float is unlocked.
7. Press and hold button (A) on the heads-up display for 3 seconds to enter diagnostic mode.
8. Scroll down using button (B) until LEFT is displayed on the LCD screen.
9. Press OK button (C). The number indicated on the LCD screen is the voltage reading from the sensor of the AHHC. Raise and lower the header to see the full range of the voltage readings.
10. If the sensor voltage is not within the lower and upper limits, or if the range between the lower and upper limits is insufficient, refer to [8.1.3 Manually Checking Voltage Limits, page 269](#).

Engaging Auto Header Height Control – Gleaner® R65, R66, R75, R76, and Pre-2016 S Series

The auto header height control (AHHC) must be engaged before you can adjust it for height and sensitivity.

⚠ DANGER

Ensure that all bystanders have cleared the area.

NOTE:

Changes may have been made to the combine controls or the display since this document was published. For the most up-to-date information, refer to the combine operator's manual.

The following system components are required in order for the auto header height control (AHHC) to work:

- Main module and header driver module mounted in card box in fuse panel (FP) module.
- Multifunction control handle operator inputs.
- Operator inputs mounted in the control console (CC) module panel.
- Electrohydraulic header lift control valve.

SETTING UP AUTO HEADER HEIGHT CONTROL SYSTEM



1003579

Figure 8.185: Combine Auto Header Height Controls

1. Press AUTO MODE button (A) until AHHC LED light (B) begins flashing. If the RTC light is flashing, press AUTO MODE button (A) again until it switches to the AHHC.
2. Briefly press button (A) on the control handle. The AHHC light should change from flashing to solid. The header should drop to the ground. The AHHC is now engaged and can be adjusted for height and sensitivity.
3. Use the controls to adjust the height and sensitivity to the constant changing ground conditions such as shallow gullies and field drainage trenches.

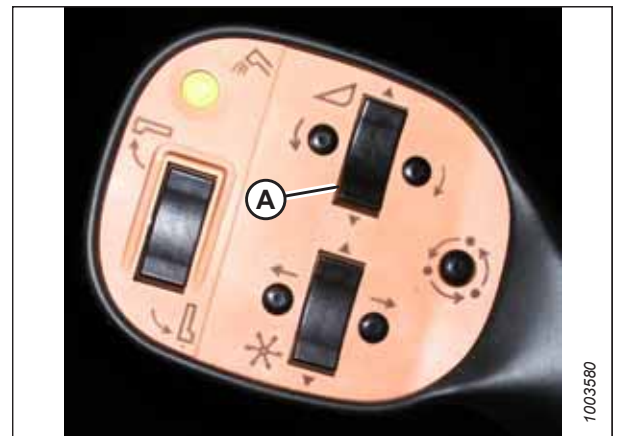

1003580

Figure 8.186: Control Handle

Calibrating Auto Header Height Control – Gleaner® R65, R66, R75, R76, and Pre-2016 S Series

The auto header height control (AHHC) sensor output must be calibrated for each combine.

! DANGER

To prevent bodily injury or death from the unexpected start-up of the machine, always stop the engine and remove the key from the ignition before making adjustments to the machine.

! DANGER

Ensure that all bystanders have cleared the area.

SETTING UP AUTO HEADER HEIGHT CONTROL SYSTEM

NOTE:

Calibration should be done on flat, level ground without the header engaged. The header height and header tilt functions must not be in auto or standby modes. The engine rpm must be above 2000 rpm. The header tilt option on 2004 and earlier model combines does not work with MacDon headers. This system will have to be removed and disabled in order to calibrate the AHHC. For instructions, refer to the combine operator's manual.

NOTE:

Changes may have been made to the combine controls or the display since this document was published. For the most up-to-date information, refer to the combine operator's manual.

NOTE:

If the header float is set too light, it can prevent the calibration of the AHHC. In order to prevent the header from separating from the float module, it may be necessary to change the float to a heavier setting during calibration.

1. Park the combine on a level surface.
2. Ensure that the header is level with the ground. If adjustment is required, refer to [10.5 Leveling Header, page 526](#).

NOTE:

Spirit level (A) is located on top of the float module frame. The header is level if the bubble is in the center of the spirit level.

3. Ensure that the center-link is set to **D**.

NOTE:

When calibration is complete, adjust the center-link back to the desired header angle. For instructions, refer to the header operator's manual.

4. Adjust the reel fore-aft position so that the indicator is at position **6**.
5. Position the header so that the cutterbar is 254–356 mm (10–14 in.) off the ground.
6. Shut down the engine, and remove the key from the ignition.

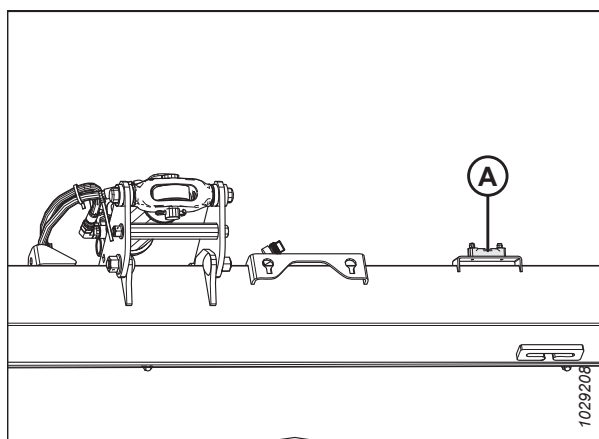

Figure 8.187: Spirit Level

SETTING UP AUTO HEADER HEIGHT CONTROL SYSTEM

CAUTION

To prevent cuts, pinches, and other bodily harm to the person checking the down stops, ensure that nobody is manually lifting, bouncing, or moving the header in any way while the down stop washer is being touched and checked for movement.

7. Ensure that the float lock linkage is on the down stops (washer [A] cannot move) at both locations.

NOTE:

If the header is **NOT** on the down stops, the voltage may go out of range during operation and cause the AHHC system to malfunction. To fix the problem, make the header heavier by decreasing the float. For instructions, refer to [6.10 Checking and Adjusting Header Float, page 229](#).

8. Unlock the header float. For instructions, refer to the header operator's manual.

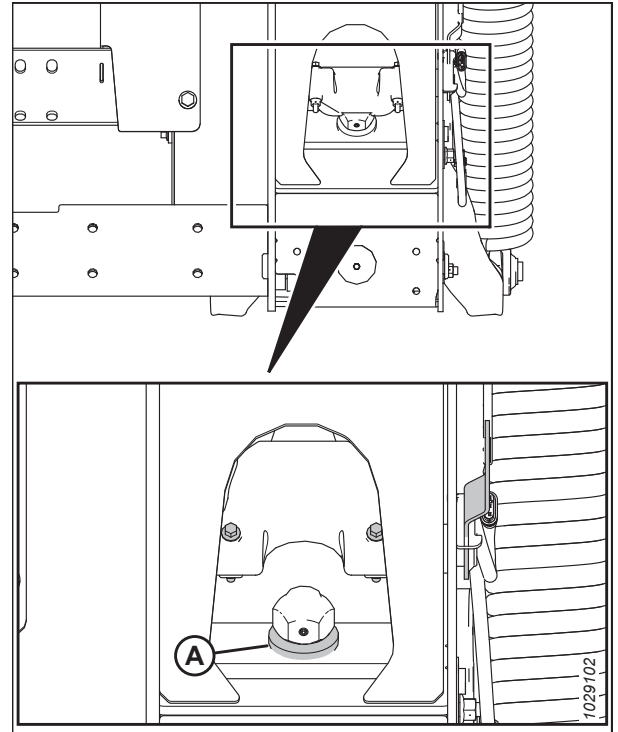

Figure 8.188: Down Stop Washer

SETTING UP AUTO HEADER HEIGHT CONTROL SYSTEM

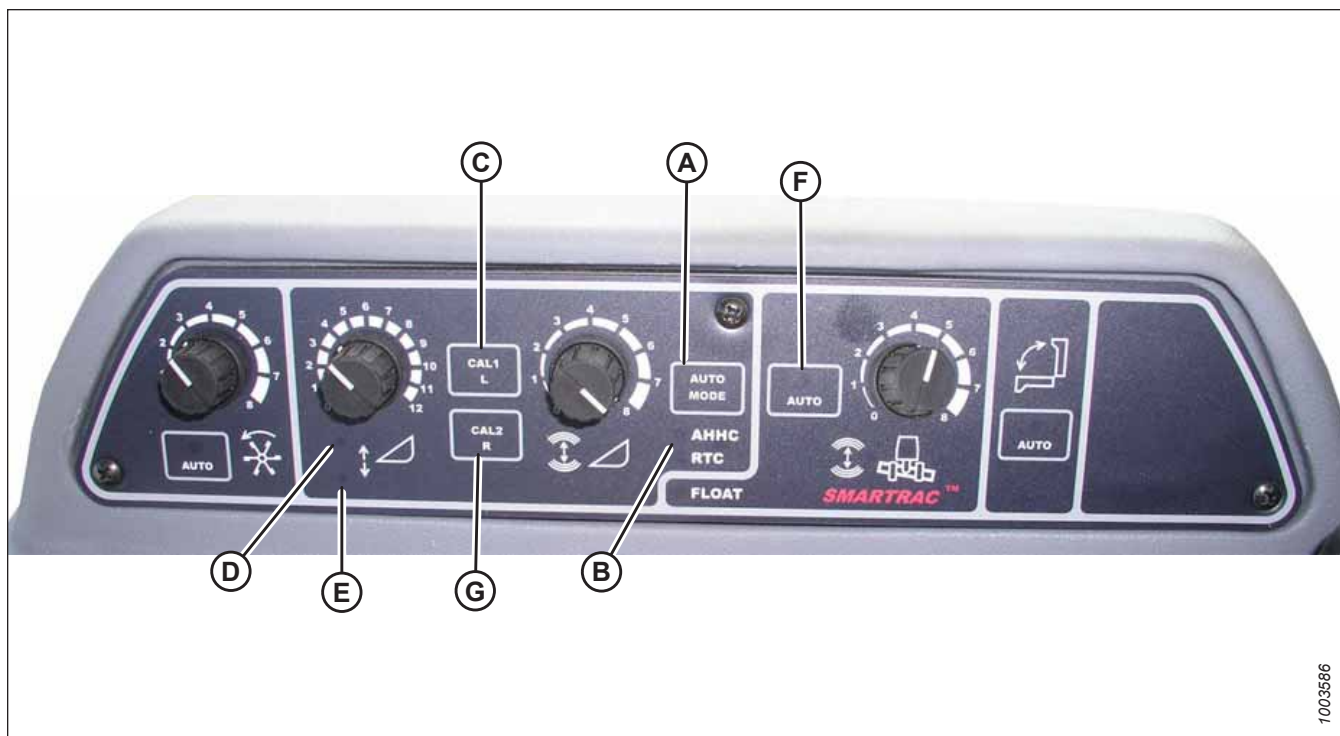

Figure 8.189: Combine Auto Header Height Controls

A - AUTO MODE Button
D - Raise Header Light
G - CAL2 Button

B - AHHC Light
E - Lower Header Light

C - CAL1 Button
F - AUTO Mode

9. Press AUTO MODE button (A) until AHHC light (B) lights up.
 10. Press and hold CAL1 button (C) until you see the following lights flash: raise header (D), lower header (E), tilt AUTO MODE (F), and AHHC (B).
 11. Fully lower the header, and continue to hold the HEADER LOWER button for 5–8 seconds to ensure that the float module has separated from the header.
 12. Press CAL2 button (G) until lower header light (E) stops flashing, and release it when raise header light (D) begins flashing.
 13. Raise the header to its maximum height, and ensure that the header is resting on the down stop pads.
 14. Press CAL2 button (G) until raise header light (D) turns off.
- NOTE:**
The following steps are applicable only to 2005 and later combines with the Smartrac feeder house.
15. Wait for the HEADER TILT LEFT light (not shown) to start flashing, and then tilt the header to the maximum left position.
 16. Press CAL2 button (G) until the HEADER TILT LEFT light (not shown) stops flashing, and release the button when the HEADER TILT RIGHT light (not shown) begins flashing.
 17. Tilt the header to the maximum right position.
 18. Press CAL2 button (G) until all of the following lights flash: raise header (D), lower header (E), height AUTO MODE (A), right header and left header (not shown), and tilt AUTO MODE (F).

SETTING UP AUTO HEADER HEIGHT CONTROL SYSTEM

- Center the header.
- Press CAL1 button (C) to exit calibration and save all values. All lights should stop flashing.

NOTE:

If the float was set heavier to complete the AHHC calibration procedure, adjust it to the recommended operating float after the calibration is complete.

Turning off Accumulator – Gleaner® R65, R66, R75, R76, and Pre-2016 S Series

The accumulator affects the combine's height adjustment reaction time, which can affect the auto header height control (AHHC) system's performance.

For best performance, turn the feeder house accumulator off. For instructions, refer to the combine operator's manual.

NOTE:

The accumulator is located in front of the front left axle beam.



Figure 8.190: Combine Accumulator ON/OFF Switch
A - Accumulator Lever (Off Position)

SETTING UP AUTO HEADER HEIGHT CONTROL SYSTEM

Adjusting Header Raise/Lower Rate – Gleaner® R65, R66, R75, R76, and Pre-2016 S Series

The auto header height control (AHHC) system's stability is affected by hydraulic flow rates. Adjust the header raise/lower rate to ensure the stability of the auto header height control system.

Adjust header raise restrictor (A) and header lower restrictor (B) in the hydraulic manifold so that it takes approximately 6 seconds to raise the header from the ground to maximum height (that is, to the point at which the hydraulic cylinders are fully extended), and approximately 6 seconds to lower the header from maximum height to ground level.

If there is excessive header movement (for example, hunting) when the header is on the ground, adjust the lower rate so that it takes 7 or 8 seconds for the header to drop down to ground level.

NOTE:

Make this adjustment with the hydraulic system at its normal operating temperature (54.4°C [130°F]) and the engine running at full throttle.



Figure 8.191: Header Raise and Lower Adjustable Restrictors

Adjusting Ground Pressure – Gleaner® R65, R66, R75, R76, and Pre-2016 S Series

Adjust the header ground pressure setting so that the pressure is as light as possible, but sufficiently heavy that the header does not bounce while in operation.

NOTE:

Changes may have been made to the combine controls or the display since this document was published. For the most up-to-date information, refer to the combine operator's manual.

1. Ensure that indicator (A) is at position 0 (B) when the header is 254–356 mm (10–14 in.) off the ground. If it is not, check the float sensor output voltage. For instructions, refer to [Checking Voltage Range from Combine Cab – Gleaner® R65, R66, R75, R76, and Pre-2016 S Series, page 350](#).

NOTE:

When the header is on the ground, the indicator should be at position 1 (C) for low ground pressure, and at position 4 (D) for high ground pressure. Crop and soil conditions determine the amount of float to use. The ideal setting is as light as possible without the header bouncing or missing crop. Operating with heavy settings prematurely wears the cutterbar wearplates.

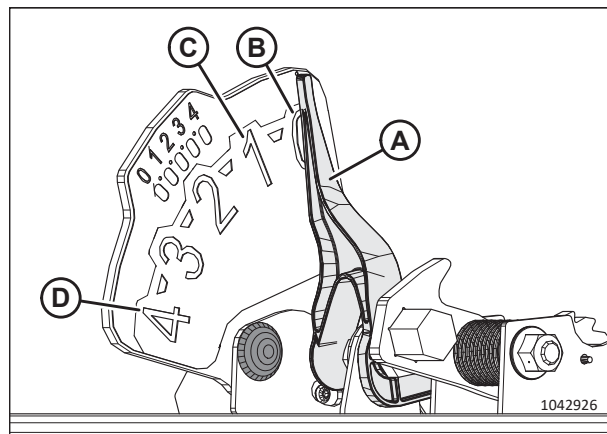

Figure 8.192: Float Indicator

SETTING UP AUTO HEADER HEIGHT CONTROL SYSTEM

2. Ensure that the header is in auto header height control (AHHC) mode. This is indicated by AUTO MODE LED light (A) displaying a continuous, solid light.
3. The header will lower to the height (ground pressure) corresponding to the position selected with height control knob (B). Turn the knob counterclockwise for minimum ground pressure and clockwise for maximum ground pressure.

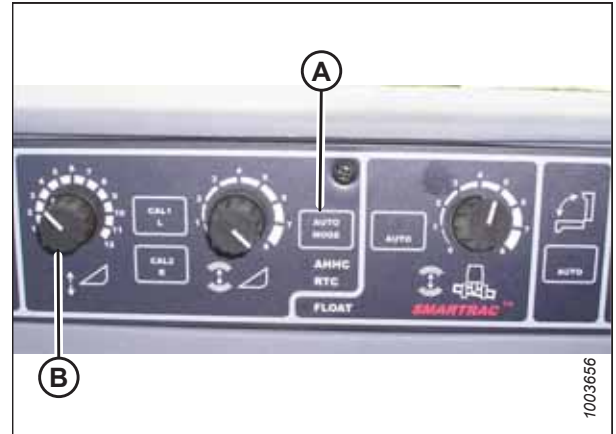

Figure 8.193: AHHC Console

Adjusting Auto Header Height Control Sensitivity – Gleaner® R65, R66, R75, R76, and Pre-2016 S Series

Auto header height control (AHHC) sensitivity refers to the distance that the cutterbar must travel up or down before the AHHC reacts and raises or lowers the feeder house.

NOTE:

Changes may have been made to the combine controls or the display since this document was published. For the most up-to-date information, refer to the combine operator's manual.



Figure 8.194: Auto Header Height Control Console

SENSITIVITY ADJUSTMENT dial (A) controls the distance the cutterbar must travel up or down before the AHHC reacts and raises or lowers the feeder house.

When SENSITIVITY ADJUSTMENT dial (A) is set to maximum (turned completely clockwise), only small changes in ground height are needed to cause the feeder house to raise or lower. In this position, the cutterbar moves up and down

SETTING UP AUTO HEADER HEIGHT CONTROL SYSTEM

approximately 19 mm (3/4 in.) before the control module signals the hydraulic control valve to raise or lower the header frame.

When SENSITIVITY ADJUSTMENT dial (A) is set to minimum (turned completely counterclockwise), large changes in ground height are needed to cause the feeder house to raise or lower. In this position, the cutterbar moves up and down approximately 51 mm (2 in.) before the control module signals the hydraulic control valve to raise or lower the header frame.

The HEADER SENSE LINE input also changes the range of the sensitivity. When connected to a draper, the counterclockwise position (least sensitive) allows for approximately 102 mm (4 in.) of vertical travel before correction is made.

Troubleshooting Alarms and Diagnostic Faults – Gleaner® R65, R66, R75, R76, and Pre-2016 S Series

Refer to this section to learn the meaning of the alarms and faults related to the auto header height control (AHHC) system. Alarms and diagnostic faults are displayed on the combine's electronic instrument panel (EIP).

NOTE:

Changes may have been made to the combine controls or the display since this document was published. For the most up-to-date information, refer to the combine operator's manual.

Display type:

Displayed on tachometer (A) as XX or XXX.



Figure 8.195: Tachometer

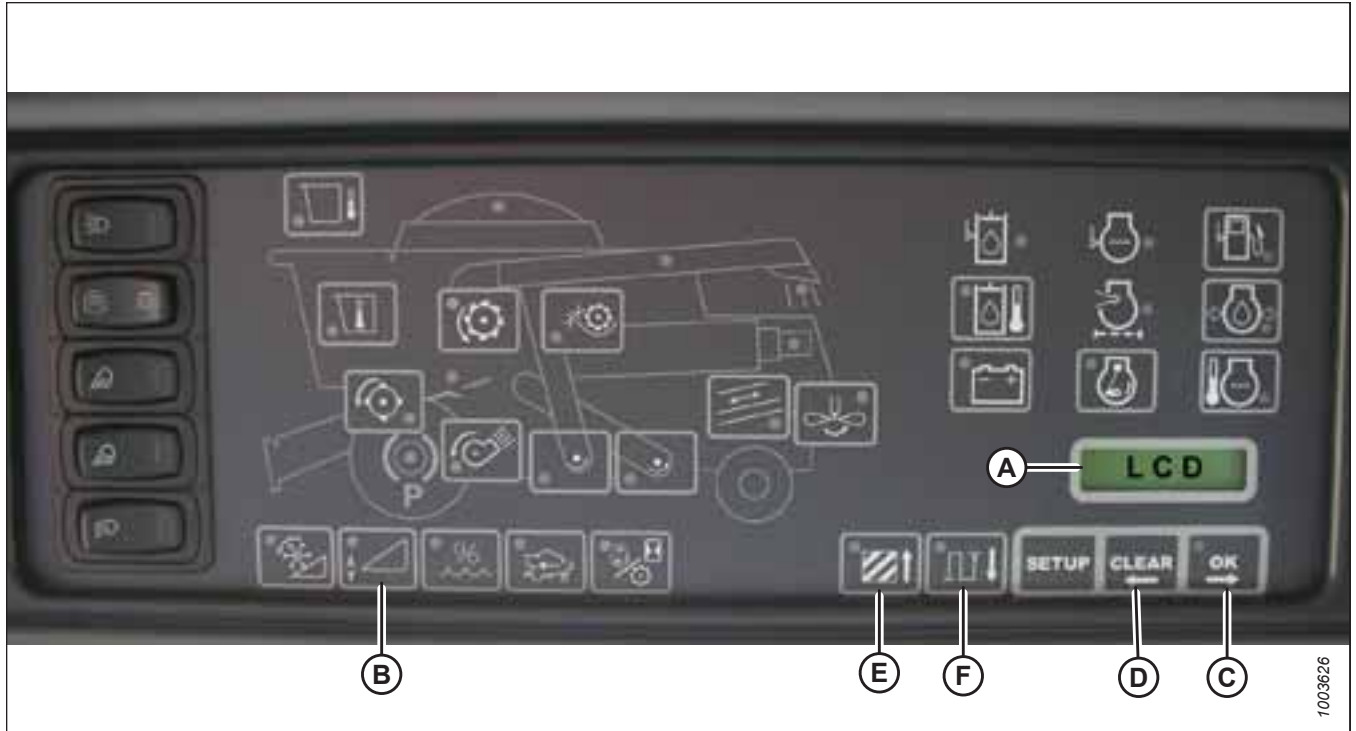

Figure 8.196: Combine Electronic Instrument Panel (EIP)

NOTE:

Displayed on LCD (A) as XX in. or XXX cm.

Alarm conditions:

If an error message is received from the fuse panel, an alarm sounds. The alarm buzzer sounds five times every 10 seconds. LCD (A) on the electronic instrument panel (EIP) indicates the header system in error as HDR CTRL followed by HGT ERR for height, and HDR CTRL followed by TILT ERR for tilt. The header height LED flashes yellow two times every second.

When an alarm condition occurs, a green LED flashes (green, yellow, or red depending on the input). In addition, a message is displayed on the LCD to identify the nature of the alarm. For example, HYD TEMP, OPEN, SHRT will be flashed alternately.

Diagnostic fault failures:

Refer to Figure 8.196, page 361.

Pressing header height switch (B) for a minimum of 5 seconds will put the EIP in header diagnostic mode. The LCD (shown on previous screen) will display the message HDR DIAG when the EIP has entered header diagnostic mode.

In this mode, after 3 seconds, header fault parameter labels are displayed on the EIP LCD. All the information displayed is read-only.

OK (C) and CLEAR (D) buttons allow you to scroll through the list of parameters. If there are no active fault codes, the EIP LCD will display NO CODE.

When a parameter is displayed, its label is displayed for 3 seconds, after which its value is automatically displayed.

Pressing OK button (C) while the value is displayed will advance to the next parameter and display its label.

When a parameter label is displayed and OK button (C) is pressed before 3 seconds, the parameter's value will be displayed.

Pressing AREA (E) will cycle through the options. When LEFT is displayed on the LCD, press OK button (C), and the auto header height control (AHHC) voltage will be shown on the display.

Press DIST button (F) to cycle back through the table.

SETTING UP AUTO HEADER HEIGHT CONTROL SYSTEM

Press CLEAR button (D) to exit header diagnostics and return to normal mode.

8.1.12 Gleaner® S9 Series Combines

To make your header's auto header height control (AHHC) system compatible with the combine, configure the reel speed settings, set up the AHHC controls, and calibrate the AHHC system to ensure that it is working correctly.

Setting up Header – Gleaner® S9 Series

To set up a header to work with the auto header height control (AHHC) system, you will need to access the HEADER SETTINGS menu using the Tyton terminal.

NOTE:

Changes may have been made to the combine controls or the display since this document was published. For the most up-to-date information, refer to the combine operator's manual.

AGCO Tyton terminal (A) is used to set up and manage a MacDon header on Gleaner® S9 Series Combines. Use the touch screen display to select the desired item on the page.



Figure 8.197: Operator's Station – Gleaner® S9

A - Tyton Terminal B - Control Handle
C - Throttle D - Header Control Cluster

1. On the top right quadrant of the home page, select COMBINE icon (A). The COMBINE MAIN MENU opens.



Figure 8.198: Combine Icon on Home Page

SETTING UP AUTO HEADER HEIGHT CONTROL SYSTEM

2. On the COMBINE MAIN MENU, select HEADER SETTINGS (A). The HEADER SETTINGS page appears.

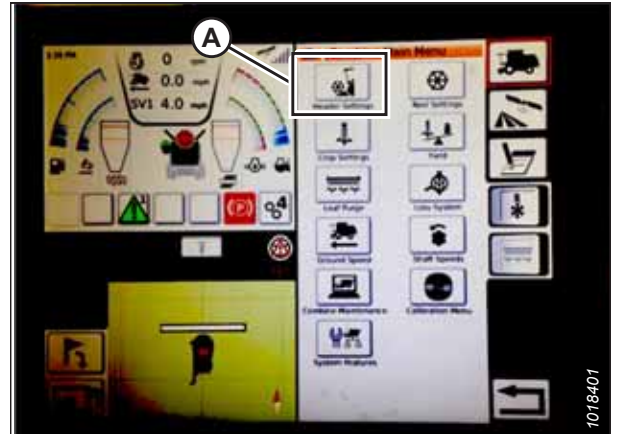
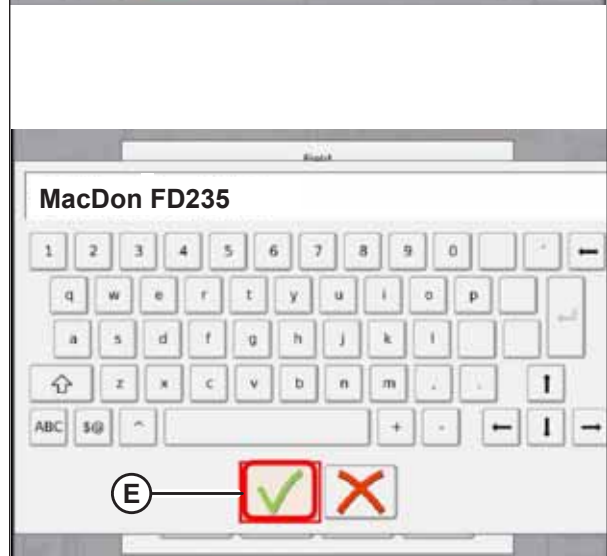
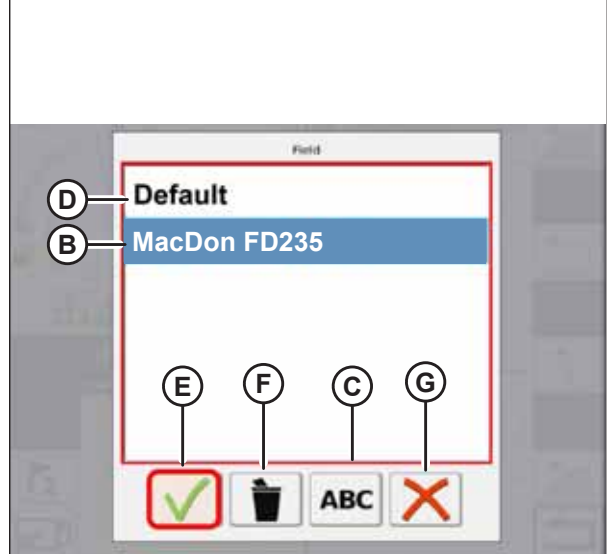
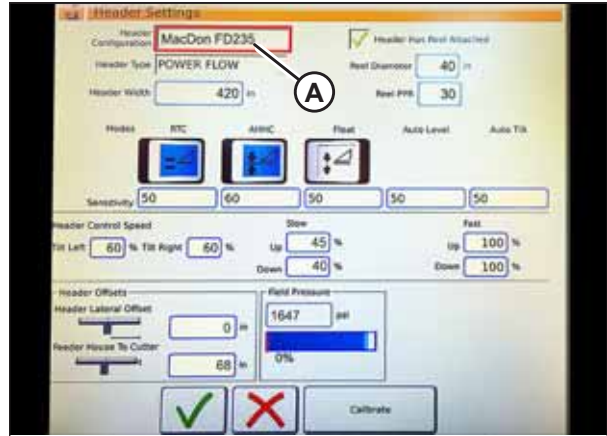

Figure 8.199: Header Settings in Combine Main Menu

SETTING UP AUTO HEADER HEIGHT CONTROL SYSTEM

3. Select HEADER CONFIGURATION field (A). A list of headers appears.
 - If your MacDon header is already set up, it should appear on the header list. Select MacDon header (B) to highlight the header in blue, then select green check mark (E) to continue.
 - If only DEFAULT header (D) is shown, select ABC button (C) and use the on-screen keyboard to enter the MacDon header information. After entering the information, select one of the following options to return to the HEADER SETTINGS page:
 - Green check mark (E) saves the settings
 - Garbage can icon (F) deletes the highlighted header from the list
 - Red X (G) cancels the change(s)



1035985

Figure 8.200: Header Configuration Menu on Header Settings Page

SETTING UP AUTO HEADER HEIGHT CONTROL SYSTEM

- To specify the type of header installed on the machine, select HEADER TYPE field (A). A list of header types appears.

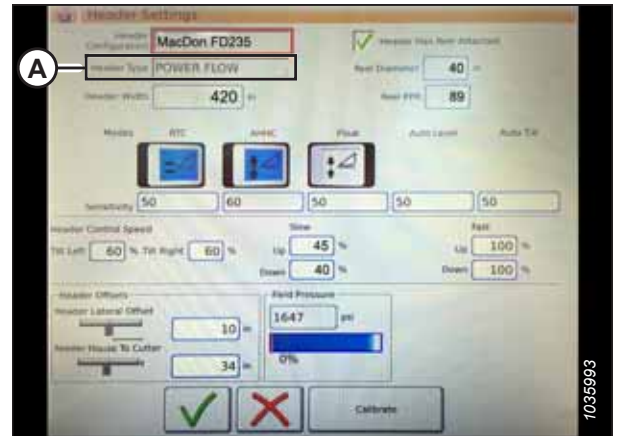

Figure 8.201: Header Settings

- Select POWER FLOW (A). Select green check mark (B) to save the selection.

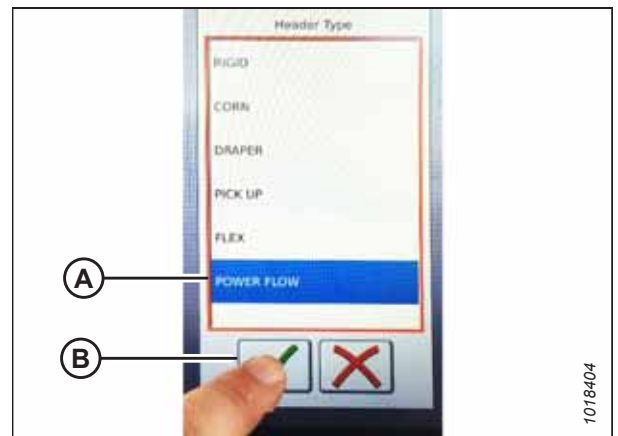

Figure 8.202: Header Type

- Ensure that HEADER HAS REEL ATTACHED check box (A) is checked.

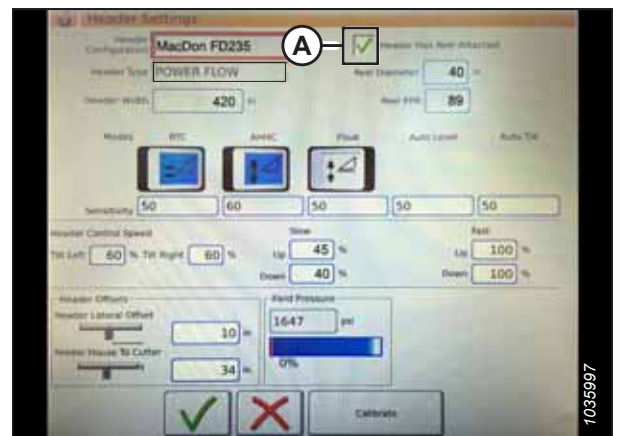

Figure 8.203: Header Settings

SETTING UP AUTO HEADER HEIGHT CONTROL SYSTEM

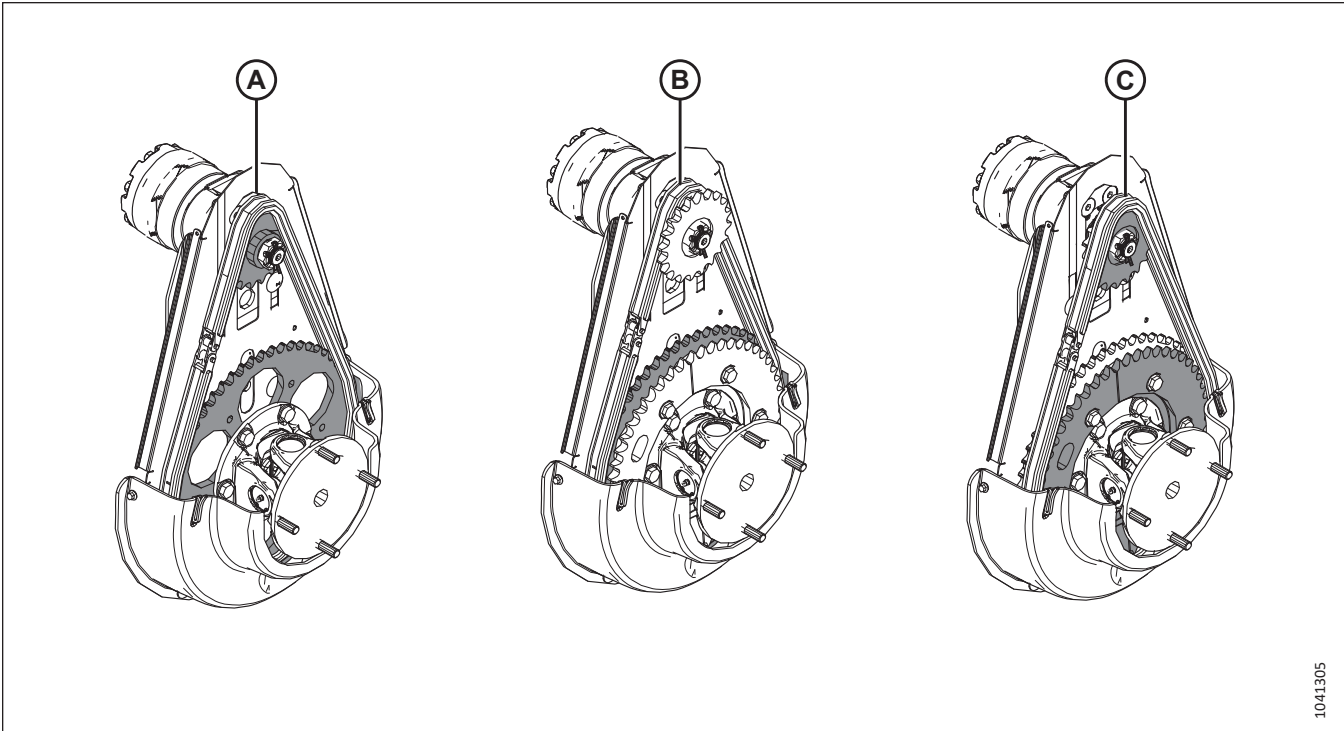

Figure 8.204: Reel Drive Configurations

7. If the type of reel drive configuration installed on the header is not already known, identify it as follows:

- (A) Standard configuration: One set of sprockets is installed.
- (B) High torque/low speed: The chain is installed on the inner set of sprockets.
- (C) High speed/low torque: The chain is installed on the outer set of sprockets.

8. Select REEL DIAMETER field (A) and a numeric keypad displays. Enter **40** for a MacDon reel.

9. Select REEL PPR (pulses per revolution) field (B). Enter the value according to the type of reel drive sprocket configuration identified in Step 7, [page 366](#):

- Standard configuration: **192**
- High torque/low speed: **303**
- Low torque/high speed: **169**

NOTE:

When AHHC is enabled, the reel should move slightly faster than the combine's ground speed. If the reel moves faster or slower than desired with the above PPR setting, contact your Dealer for assistance.

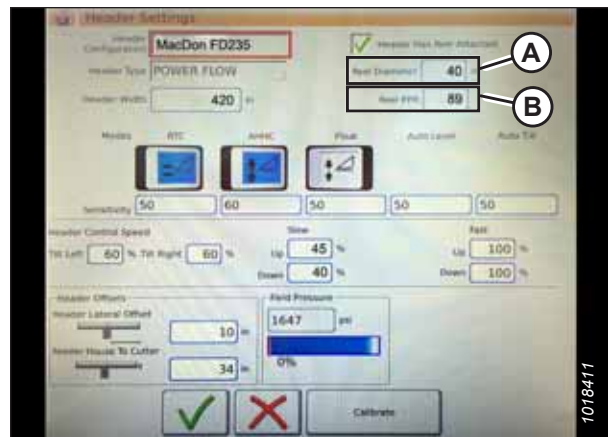

Figure 8.205: Header Settings

SETTING UP AUTO HEADER HEIGHT CONTROL SYSTEM

10. Select green check mark (B) below numeric keypad (A).

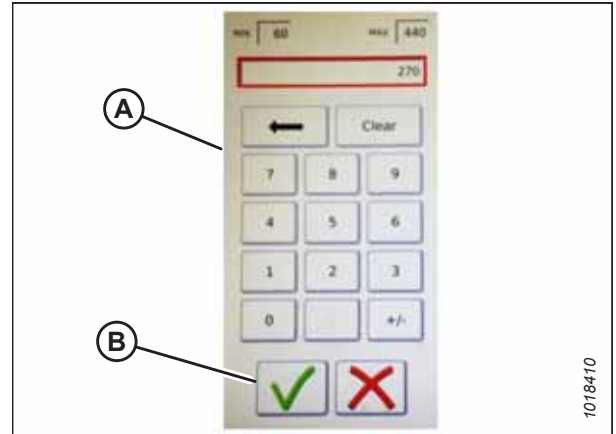

Figure 8.206: Numeric Keypad

11. Select green check mark (A) at the bottom of the HEADER SETTINGS page.

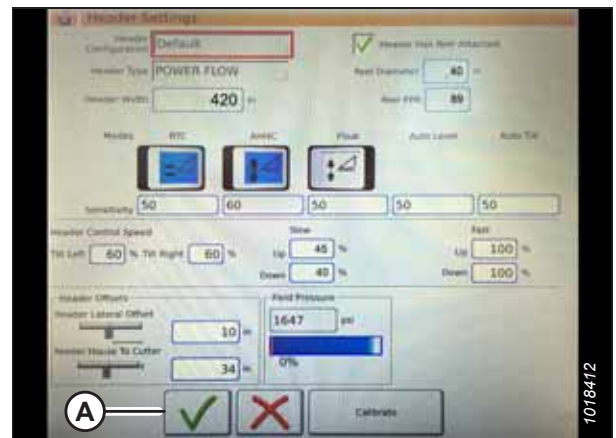

Figure 8.207: Header Settings Page

Setting Minimum Reel Speed and Calibrating Reel – Gleaner® S9 Series

To set up the header's minimum reel speed to work with the auto header height control (AHHC) system and to calibrate the reel, access the REEL SETTINGS menu.

DANGER

Ensure that all bystanders have cleared the area.

NOTE:

Changes may have been made to the combine controls or the display since this document was published. For the most up-to-date information, refer to the combine operator's manual.

SETTING UP AUTO HEADER HEIGHT CONTROL SYSTEM

1. From the COMBINE MAIN MENU, select REEL SETTINGS (A). The REEL SETTINGS page opens.



Figure 8.208: Reel Settings on Combine Main Menu

2. To set the minimum reel speed, select SPEED MINIMUM FIELD (B). The on-screen keyboard appears.
3. Input the desired value. Select the green check mark to enter the new value or select the red X to cancel input. The reel speed is shown in mph and rpm.

NOTE:

At the bottom of the REEL SETTINGS page, the reel diameter and the reel pulses per revolution (PPR) are displayed. These values have already been set in the HEADER SETTINGS page.

4. To calibrate the reel speed, select CALIBRATE button (A) in the top right of the page. The CALIBRATION WIZARD opens and displays a hazard warning.
5. Review the conditions listed in the CALIBRATION WIZARD warning and ensure that all of the conditions are met. Press green check mark (A) to accept and start calibration. Pressing red X (B) will cancel the calibration procedure.



Figure 8.209: Reel Settings Calibration

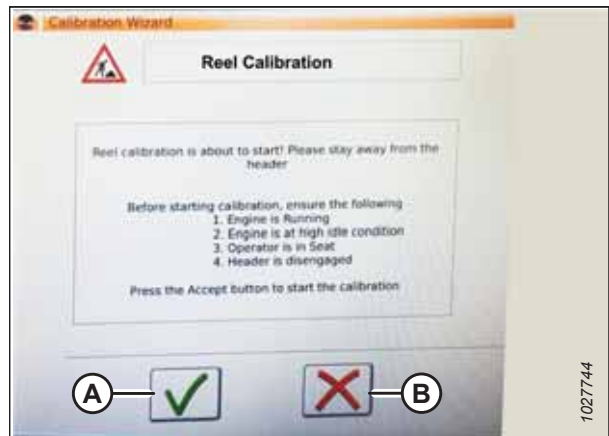

Figure 8.210: Calibration Wizard

SETTING UP AUTO HEADER HEIGHT CONTROL SYSTEM

6. A message appears in the CALIBRATION WIZARD stating that reel calibration has started. The reel will begin turning slowly and increase in speed. If necessary, select the red X at the bottom of the screen to cancel the calibration process. Otherwise, wait for the message that reel calibration has completed successfully.
7. Select the green check mark at the bottom of the screen to save the calibrated settings.



Figure 8.211: Calibration Progress

Setting up Automatic Header Controls – Gleaner® S9 Series

You can configure automatic header functions on the HEADER SETTINGS page.

NOTE:

Changes may have been made to the combine controls or the display since this document was published. For the most up-to-date information, refer to the combine operator's manual.

1. **Automatic control functions:** There are toggle (OFF/ON) switches on the HEADER SETTINGS page for the automatic control functions. For MacDon headers, ensure that the following two functions are enabled as shown:
 - RTC (return to cut) (A)
 - AHHC (automatic header height control) (B)

- RTC (return to cut) (A)
 - AHHC (automatic header height control) (B)
- All other switches are disabled (not highlighted).

2. **Sensitivity:** Setting (C) controls how responsive a control (RTC or AHHC) is to a given change in sensor feedback. The setting fields are located directly below the toggle switches. To enter a new sensitivity setting, touch the setting field below the specific toggle switch, and enter the new value in the on-screen keyboard.

- Increase the sensitivity if the combine does not change the feeder position quickly enough when in Auto Mode.
- Decrease the sensitivity if the combine hunts for a position in Auto Mode.

NOTE:

The sensitivity starting points for MacDon headers are as follows:

- 50 for RTC (A)
- 60 for AHHC (B)

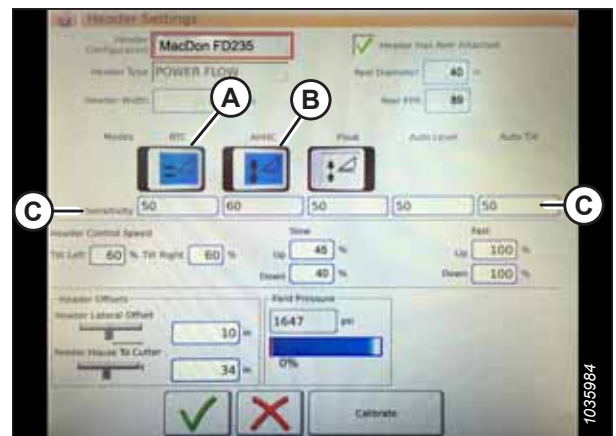

Figure 8.212: Automatic Controls and Sensitivity Settings

SETTING UP AUTO HEADER HEIGHT CONTROL SYSTEM

3. **Header speed:** HEADER CONTROL SPEED area (A) on the HEADER SETTINGS page is used to adjust the following speeds:

- Tilt left and right is the lateral tilt of the combine faceplate.
- Header up and down (slow and fast speeds) is a two-stage button with slow speed on the first detent and fast on the second.

NOTE:

The control speed starting points for MacDon headers are as follows:

- Slow: 45 up / 40 down
- Fast: 100 up / 100 down

4. **Header offsets (A):** Offset distances are important for yield mapping. There are two adjustable dimensions on the HEADER SETTINGS page:

- Header Lateral Offset: the distance between the centerline of the header and the centerline of the machine. Set to **0** for a MacDon header.
- Feeder House to Cutter: the distance from the machine interface to the cutterbar. Set to **68** for a MacDon header.

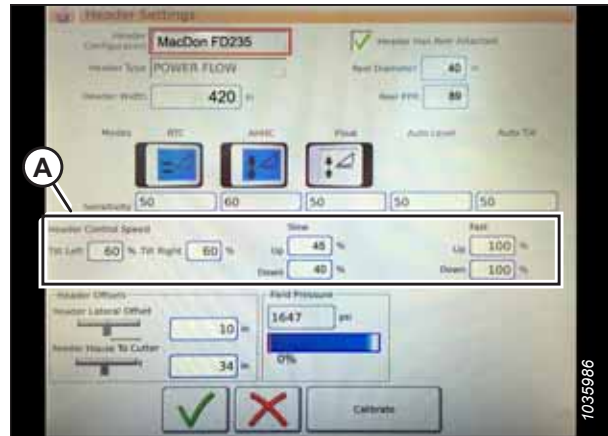

Figure 8.213: Header Speed Control Settings

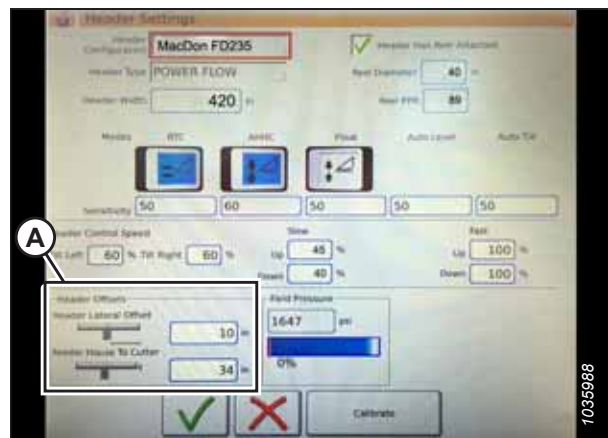

Figure 8.214: Header Offset Settings

SETTING UP AUTO HEADER HEIGHT CONTROL SYSTEM

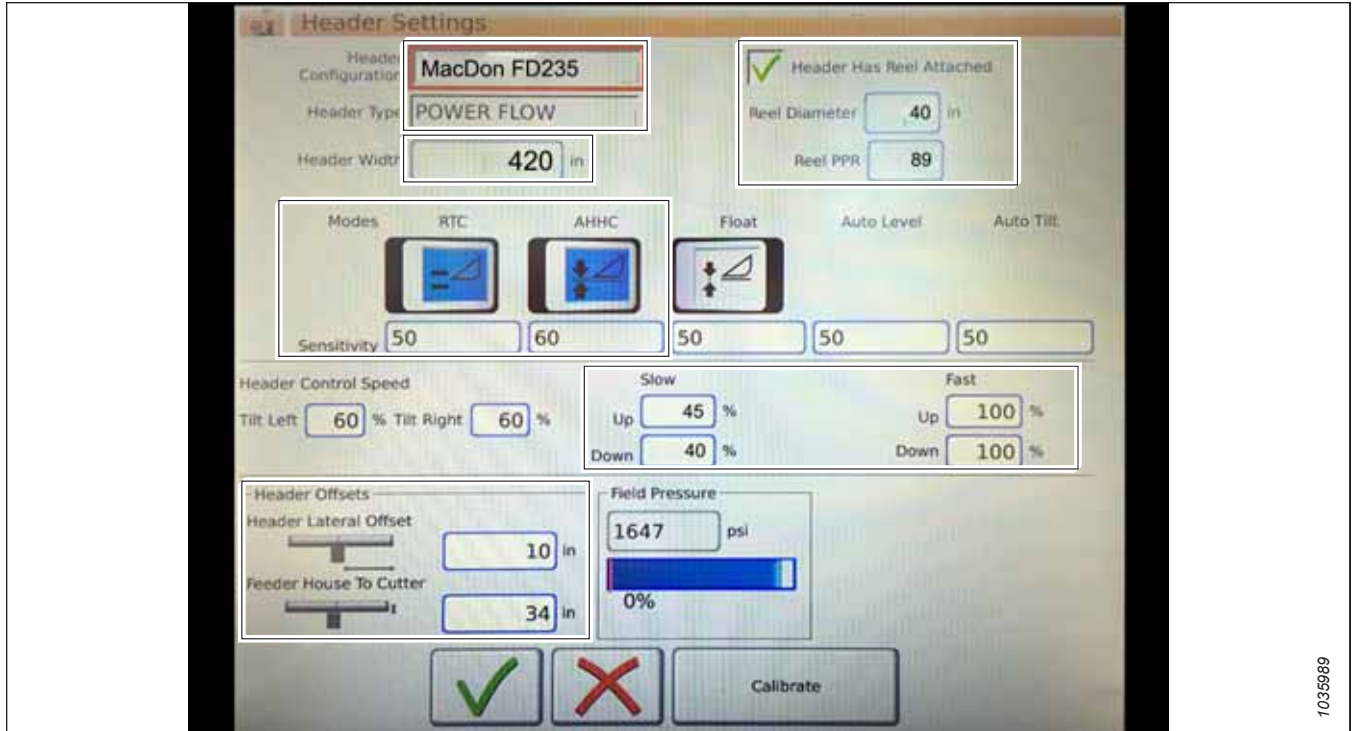

Figure 8.215: MacDon Header Settings Inputs

Calibrating Auto Header Height Control – Gleaner® S9 Series

The auto header height control (AHHC) sensor output must be calibrated for each combine, or the AHHC feature will not work properly.

DANGER

To prevent bodily injury or death from the unexpected start-up of the machine, always stop the engine and remove the key from the ignition before making adjustments to the machine.

DANGER

Ensure that all bystanders have cleared the area.

NOTE:

Changes may have been made to the combine controls or the display since this document was published. For the most up-to-date information, refer to the combine operator's manual.

NOTE:

If the header float is set too light, it can prevent the calibration of the AHHC. In order to prevent the header from separating from the float module, it may be necessary to change the float to a heavier setting during calibration.

SETTING UP AUTO HEADER HEIGHT CONTROL SYSTEM

1. Park the combine on a level surface.
2. Ensure that the header is level with the ground. If adjustment is required, refer to [10.5 Leveling Header, page 526](#).

NOTE:

Spirit level (A) is located on top of the float module frame. The header is level if the bubble is in the center of the spirit level.

3. Ensure that the center-link is set to **D**.

NOTE:

When calibration is complete, adjust the center-link back to the desired header angle. For instructions, refer to the header operator's manual.

4. Adjust the reel fore-aft position so that the indicator is at position **6**.
5. Position the header so that the cutterbar is 254–356 mm (10–14 in.) off the ground.
6. Shut down the engine, and remove the key from the ignition.

CAUTION

To prevent cuts, pinches, and other bodily harm to the person checking the down stops, ensure that nobody is manually lifting, bouncing, or moving the header in any way while the down stop washer is being touched and checked for movement.

7. Ensure that the float lock linkage is on the down stops (washer [A] cannot move) at both locations.

NOTE:

If the header is **NOT** on the down stops, the voltage may go out of range during operation and cause the AHHC system to malfunction. To fix the problem, make the header heavier by decreasing the float. For instructions, refer to [6.10 Checking and Adjusting Header Float, page 229](#).

8. Unlock the header float. For instructions, refer to the header operator's manual.

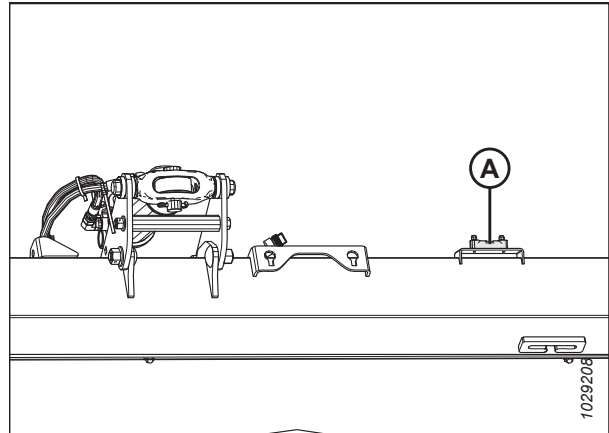

Figure 8.216: Spirit Level

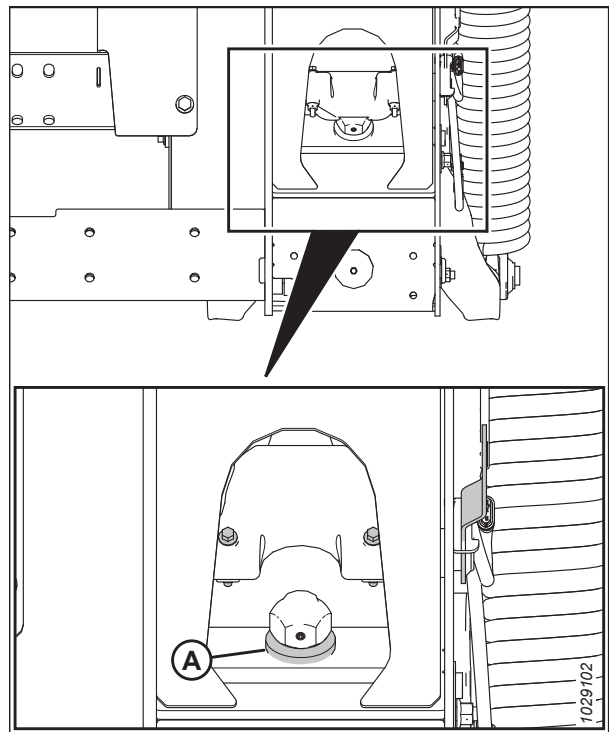

Figure 8.217: Down Stop Washer

SETTING UP AUTO HEADER HEIGHT CONTROL SYSTEM

- On the COMBINE MAIN MENU, select HEADER SETTINGS icon (A).

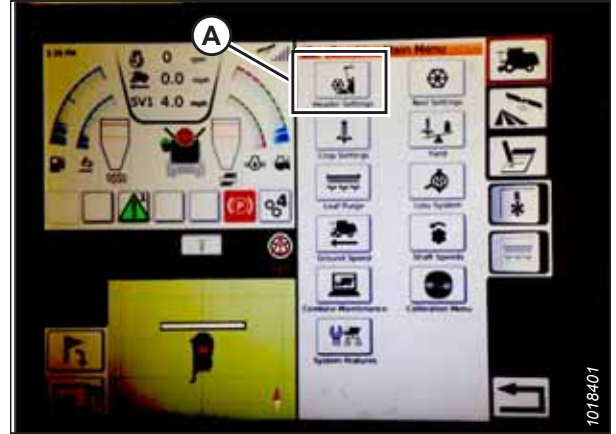

Figure 8.218: Combine Main Menu

- Select CALIBRATE (A) at the bottom right of the page. The HEADER CALIBRATION page appears.

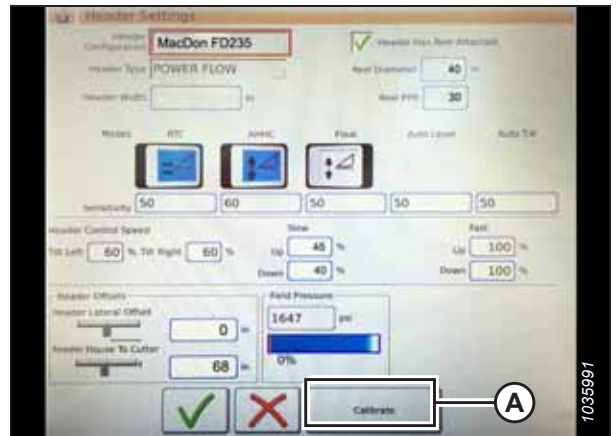

Figure 8.219: Header Settings Page

The right side of the page shows HEADER CALIBRATION information (A). The information is shown for a list of sensors (B):

- Left and right header sensor (voltage) (values will be the same with MacDon headers)
- Header height sensor (mA)
- Tilt position sensor (mA)

The following valid modes are shown with check marks (C) below sensor values (B):

- Return to cut
- Automatic header height control

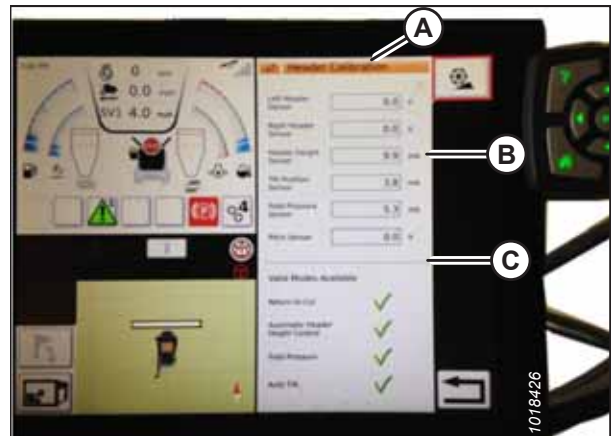

Figure 8.220: Header Calibration Page

SETTING UP AUTO HEADER HEIGHT CONTROL SYSTEM

11. On the control handle, press HEADER DOWN button (A).
The sensor values on the HEADER CALIBRATION page will change as the header falls.



Figure 8.221: Header Down Switch

12. Select CALIBRATE icon (A).



Figure 8.222: Header Calibration

13. The hazard warning for HEADER CALIBRATION appears.
Ensure that all of the conditions are met.
14. Select the green check mark at the bottom of the screen to start the CALIBRATION WIZARD.



Figure 8.223: Header Calibration Warning

SETTING UP AUTO HEADER HEIGHT CONTROL SYSTEM

A progress bar displays at the bottom of the screen. The header will move automatically and erratically during calibration; you can stop the process at any time by selecting the red X below the progress bar.

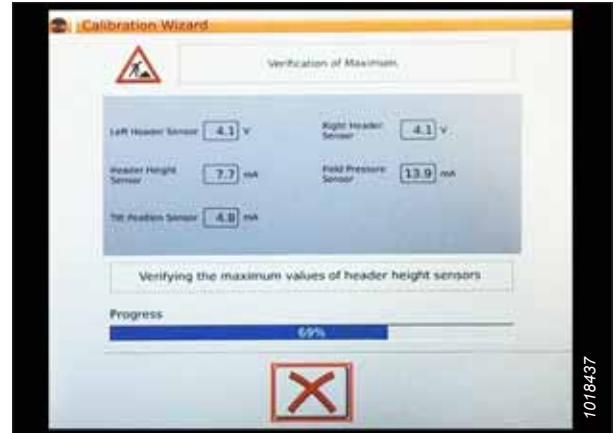

Figure 8.224: Calibration in Progress

- When the calibration process is complete, a message will appear, showing information (A). The green check marks indicate that functions (B) have been calibrated. Select green check mark (C) at the bottom of the screen to exit the calibration page.



Figure 8.225: Completed Calibration Page

NOTE:

Select CALIBRATION icon (A) on the COMBINE MAIN MENU page. The CALIBRATION MENU appears. On the CALIBRATION MENU, you can calibrate several other features, such as the header and the reel.



Figure 8.226: Direct Calibration Menu

SETTING UP AUTO HEADER HEIGHT CONTROL SYSTEM

Operating Auto Header Height Control – Gleaner® S9 Series

Once the auto header height control (AHHC) system has been set up, you can engage the AHHC system and fine-tune the position of the header by using a control dial.

NOTE:

Changes may have been made to the combine controls or the display since this document was published. For the most up-to-date information, refer to the combine operator's manual.

The following controls are used to operate the AHHC functions:

- Tyton terminal (A)
- Control handle (B)
- Throttle (C)
- Header control cluster (D)

Use the combine operator's manual to familiarize yourself with the controls.



Figure 8.227: Gleaner® S9 Operator Controls

1. With the header running, set lateral tilt switch (A) to MANUAL.
2. Engage the AHHC by pressing switch (B) to the upward position.



Figure 8.228: Header Control Cluster

SETTING UP AUTO HEADER HEIGHT CONTROL SYSTEM

3. Press AHHC control switch (A) on the control handle to engage the AHHC. The header moves to the current set point position.



Figure 8.229: AHHC on Control Handle

4. Use HEADER HEIGHT SETPOINT control dial (A) as necessary to fine-tune the position.



Figure 8.230: Header Control Cluster

Reviewing Header In-Field Settings – Gleaner® S9 Series

You can review the auto header height control (AHHC) settings by pressing the HEADER icon on the Tyton terminal's home page.

NOTE:

Changes may have been made to the combine controls or the display since this document was published. For the most up-to-date information, refer to the combine operator's manual.

SETTING UP AUTO HEADER HEIGHT CONTROL SYSTEM

1. To view the following header group settings, select HEADER icon (A) on the right side of the home page:

- CURRENT POSITION of header (B).
- SETPOINT cut-off position (C) (indicated by the red line)
- HEADER symbol (D) – select to adjust the set point cut-off position using the scroll wheel on the right side of the Tyton terminal.
- CUT HEIGHT for AHHC (E) – fine-tune with the header height set point control dial on the header control cluster.
- HEADER WORKING WIDTH (F)
- HEADER PITCH (G)

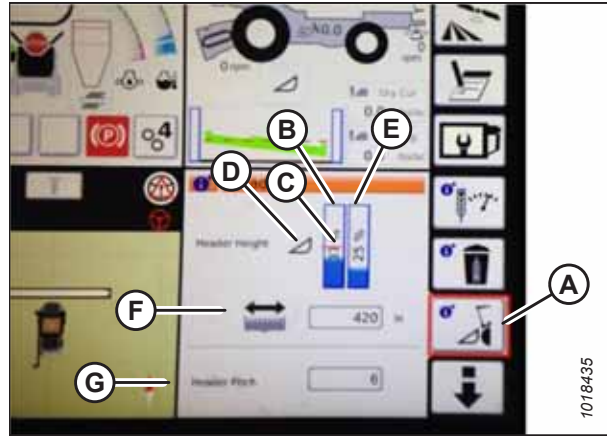

Figure 8.231: Header Groups

2. Selecting a field opens the on-screen keyboard, so that the values can be adjusted. Enter the new value and select the green check mark when complete.

NOTE:

Scroll wheel (A) is located on the right side of the Tyton terminal.



Figure 8.232: Adjustment Wheel on Right Side of Tyton Terminal

NOTE:

HEADER HEIGHT SETPOINT control dial (A) is on the header control cluster.



Figure 8.233: Header Control Cluster

SETTING UP AUTO HEADER HEIGHT CONTROL SYSTEM

Header Settings Quick Reference – Gleaner® S9 Series

The recommended auto header height control (AHHC) settings for a D2 Series Draper Header operating with a Gleaner® S9 Series combine are provided.

Table 8.6 Header Settings – Gleaner® S9 Series

Setup Parameter	Suggested Setting
Header type	Power Flow
Header has reel attached check box	Checked
Reel diameter	40
Reel PPR ²³	192
Sensitivity (RTC)	50
Sensitivity (AHHC)	60
Header control speed ²⁴	Slow: Up 45/Down 40 Fast: Up 100/Down 100
Header lateral offset	0
Feeder house to cutter	68

8.1.13 IDEAL™ Series Combines

To make your header's auto header height control (AHHC) system compatible with the combine, configure the reel speed settings, set up the AHHC controls, and calibrate the AHHC system to ensure that it is working correctly.

Header Settings Quick Reference – IDEAL™ Series

The recommended auto header height control (AHHC) settings for a header operating with an IDEAL™ Series combine are provided.

For detailed instructions, proceed to the IDEAL™ combine header setup and calibration procedures.

Table 8.7 Header Settings – IDEAL™

Setup Parameter	Suggested Setting		
Header type	Power Flow		
Reel check box	Checked		
Reel diameter	102 cm (40 in.) ²⁵		
Reel PPR ²³	Standard - 38	High-torque sprocket - 61	High-speed sprocket - 34
Sensitivity (RTC)	50		
Sensitivity (AHHC)	60		
Header control speed ²⁴	Slow: Up 45/Down 40 Fast: Up 100/Down 100		
Header lateral offset	0		
Feeder house to cutter	68		

23. Pulses per revolution.

24. A two-stage button with slow speed on the first detent and fast on the second.

25. If the reel speed does not index correctly, then the reel diameter can be increased to 112 cm (44 in.).

SETTING UP AUTO HEADER HEIGHT CONTROL SYSTEM

Setting up Header – IDEAL™ Series

Set these initial configuration options on your IDEAL™ Series combine when setting up the auto header height control (AHHC) system.

NOTE:

Changes may have been made to the combine controls or the display since this document was published. For the most up-to-date information, refer to the combine operator's manual.

Tyton terminal (A) is used to set up and manage a MacDon header on an IDEAL™ Series combine. Use the touch screen display to select the desired item on the page.



Figure 8.234: IDEAL™ Series Operator's Station

A - Tyton Terminal B - Control Handle
C - Throttle D - Header Control Cluster

1. On the top right of the home page, select COMBINE icon (A). The COMBINE MAIN MENU opens.

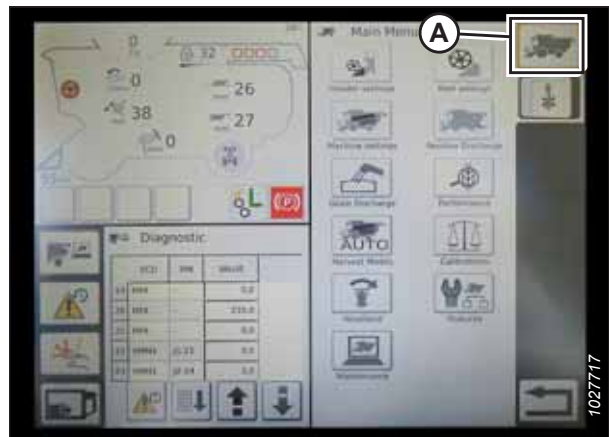

Figure 8.235: Combine Icon on Home Page

SETTING UP AUTO HEADER HEIGHT CONTROL SYSTEM

2. On the COMBINE MAIN MENU, select HEADER SETTINGS (A). The HEADER SETTINGS page opens.

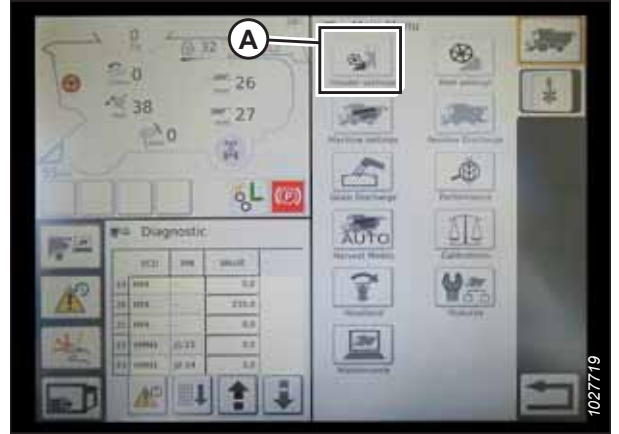

Figure 8.236: Header Settings in Combine Main Menu

SETTING UP AUTO HEADER HEIGHT CONTROL SYSTEM

3. Select HEADER CONFIGURATION field (A). A list of headers appears.
 - If a MacDon header is already set up, it appears on the list. Select MacDon header title (B) to highlight the title in blue, then select green check mark (E) to continue setup.
 - If only DEFAULT header (D) is shown, select ABC button (C) and use the on-screen keyboard to enter the header information. After entering the information, select one of the following options to return to the HEADER SETTINGS page:
 - Green check mark (E) saves the settings
 - Garbage can icon (F) deletes the highlighted header from the list
 - Red X (G) cancels the change(s)

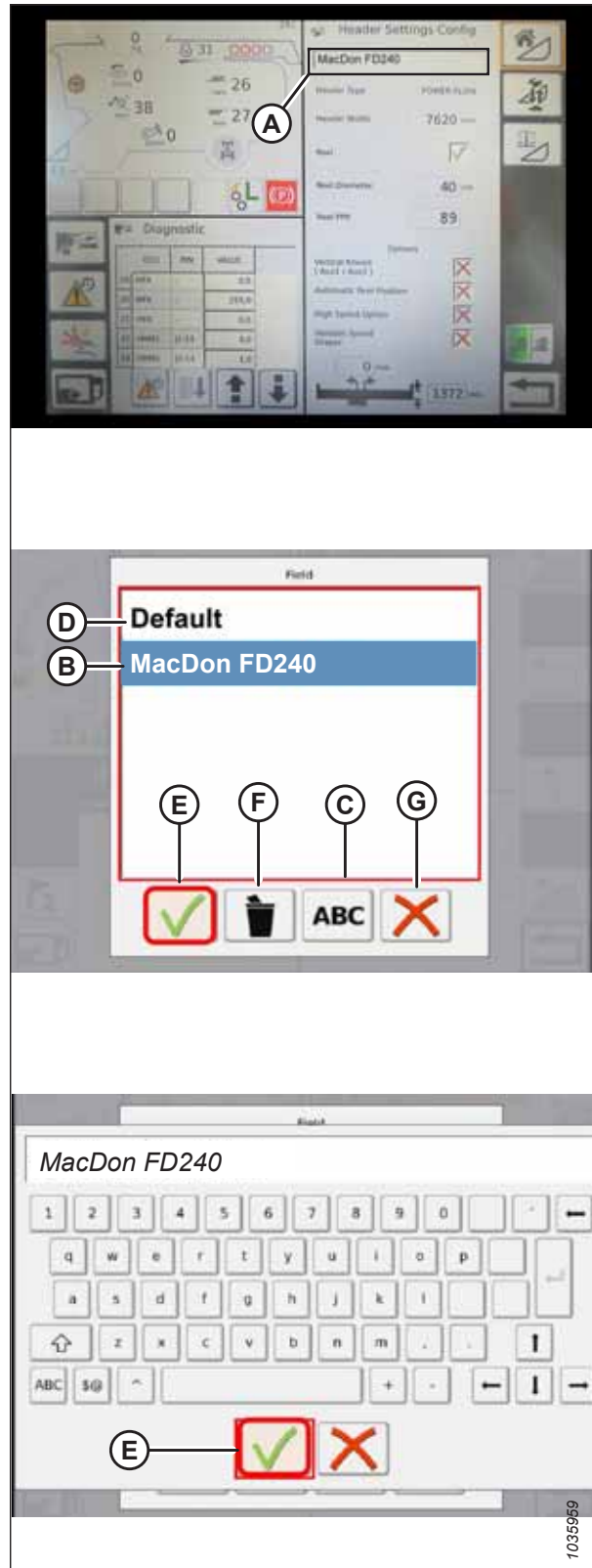

Figure 8.237: Header Configuration Menu on Header Settings Page

SETTING UP AUTO HEADER HEIGHT CONTROL SYSTEM

- To specify the type of header installed on the machine, select HEADER TYPE field (A).

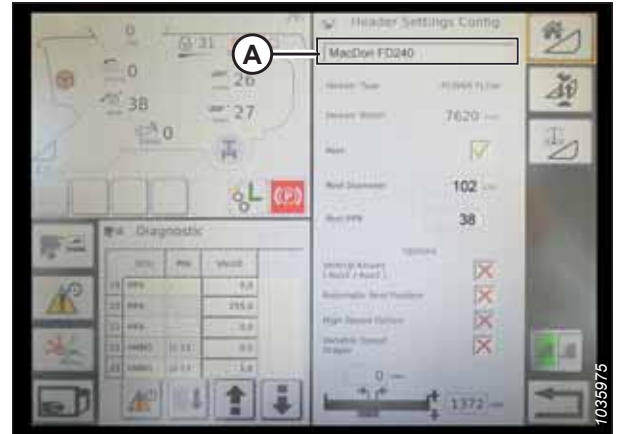

Figure 8.238: Header Settings

- From the list of predefined header types, select POWER FLOW (A).
- Select green check mark (B) to save the selection and continue.

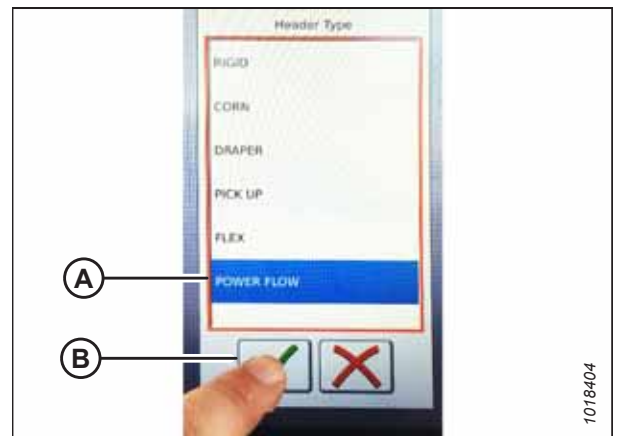

Figure 8.239: Header Type

- Ensure that REEL check box (A) is checked.

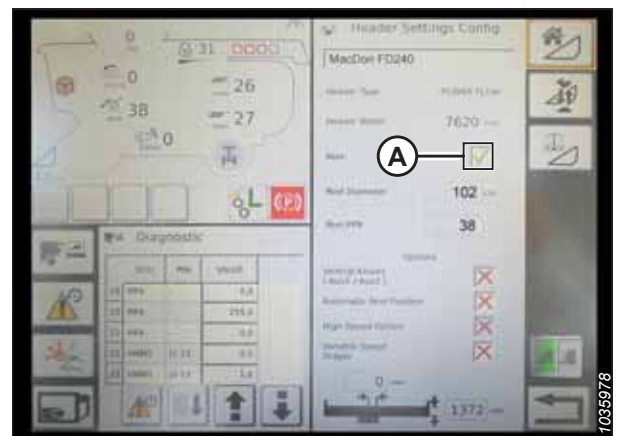

Figure 8.240: Header Settings

SETTING UP AUTO HEADER HEIGHT CONTROL SYSTEM

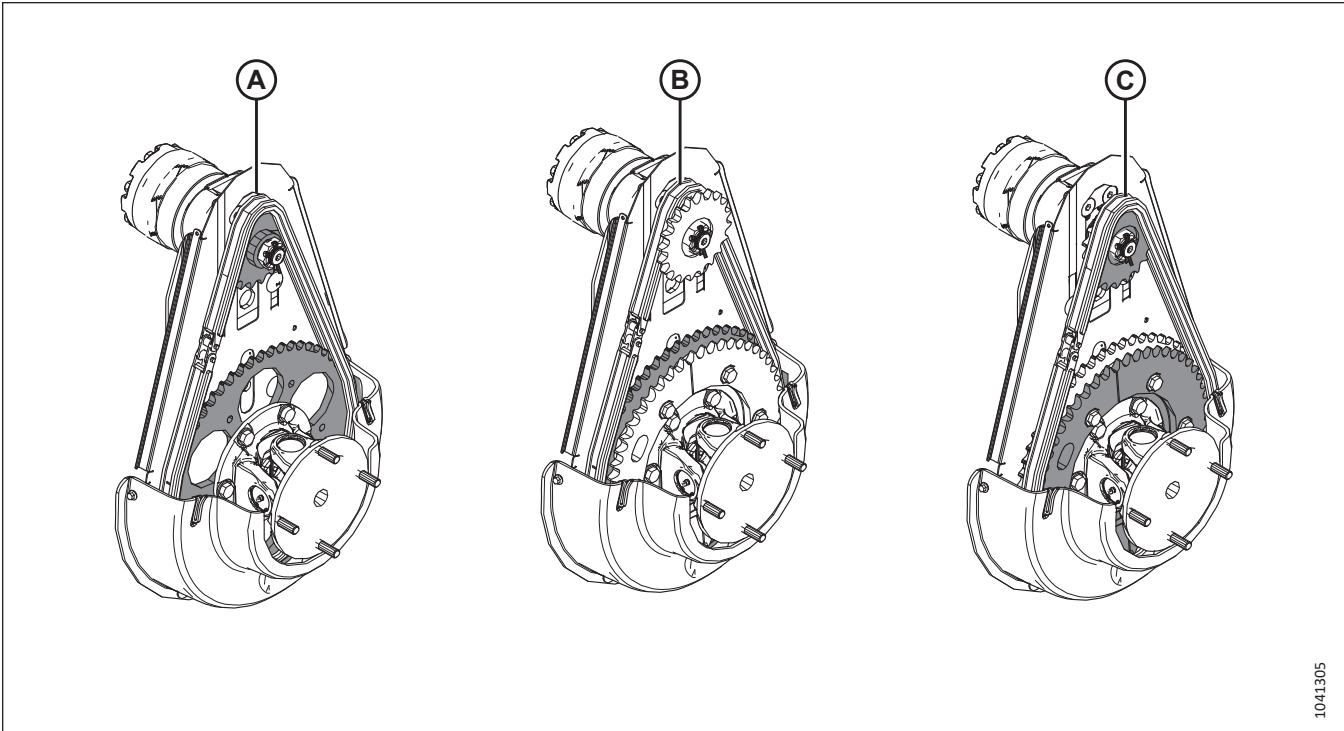

Figure 8.241: Reel Drive Configurations

8. If the type of reel drive configuration installed on the header is not already known, identify it as follows:

- Standard configuration (A): One set of sprockets is installed.
- High torque/low speed (B): The chain is installed on the inner set of sprockets.
- High speed/low torque (C): The chain is installed on the outer set of sprockets.

9. Select REEL DIAMETER field (A). A numeric keypad appears. Enter the following value for a MacDon reel:

- 102 cm (40 in.)

NOTE:

If the reel speed does not index correctly, then the reel diameter can be increased to 112 cm (44 in.).

10. Select REEL PPR (pulses per revolution) field (B) and enter the relevant value:

- **Standard:** 38
- **High torque/low speed:** 61
- **High speed/low torque:** 34

NOTE:

When AHHC is enabled, the reel should move slightly faster than the combine's ground speed. If the reel moves faster or slower than desired at the above PPR setting, contact your Dealer for assistance.

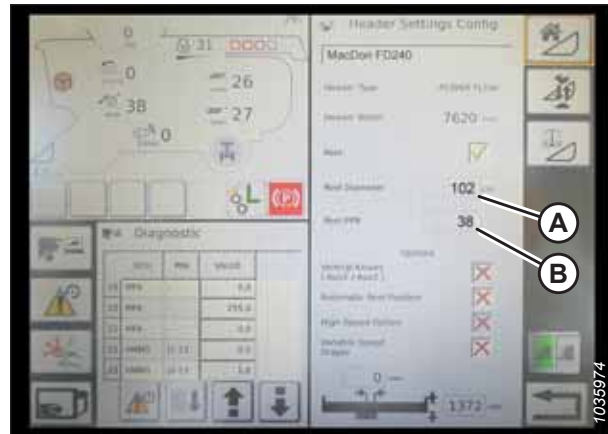

Figure 8.242: Header Settings

SETTING UP AUTO HEADER HEIGHT CONTROL SYSTEM

11. Select green check mark (B) below numeric keypad (A).

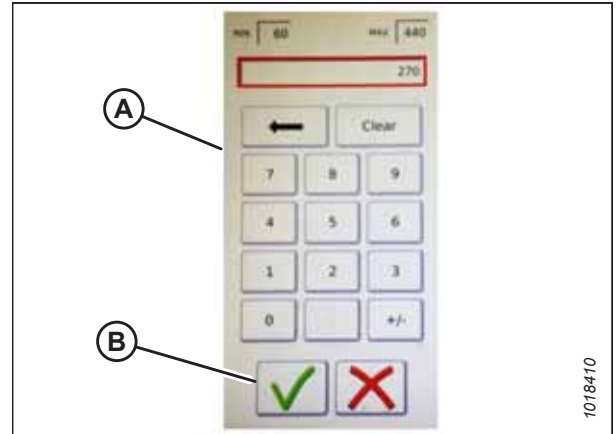

Figure 8.243: Numeric Keypad

12. Select green check mark (A) at the bottom of the HEADER SETTINGS page.

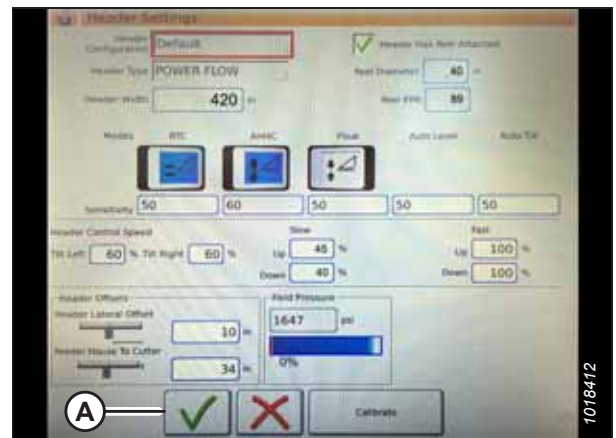

Figure 8.244: Header Settings Page

Setting Minimum Reel Speed and Calibrating Reel – IDEAL™ Series

To configure the reel speed on the header to work with the auto header height control system (AHHC) on an IDEAL™ Series combine, the reel operation parameters must be configured and the combine must run an automatic reel calibration procedure.

DANGER

Ensure that all bystanders have cleared the area.

NOTE:

Changes may have been made to the combine controls or the display since this document was published. Refer to the combine operator's manual for updated information.

SETTING UP AUTO HEADER HEIGHT CONTROL SYSTEM

1. From the COMBINE MAIN MENU, touch REEL SETTINGS (A) to open the REEL SETTINGS page.

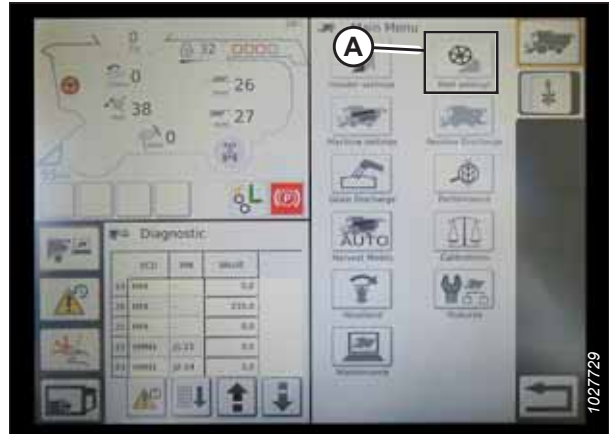

Figure 8.245: Reel Settings on Combine Main Menu

2. To set the minimum reel speed, touch SPEED MINIMUM FIELD (B). The on-screen keyboard appears. Enter the desired value. Select the green check mark to accept the new value, or the red X to cancel. The reel speed is shown in miles per hour (mph) and rotations per minute (rpm).

NOTE:

The reel diameter and reel pulses per revolution (PPR) are displayed at the bottom of the REEL SETTINGS page. These values have already been set in the HEADER SETTINGS page.

3. Select CALIBRATE button (A) at the top right corner of the REEL SETTINGS page. The CALIBRATION WIZARD appears.
4. Ensure that all of the conditions listed in the CALIBRATION WIZARD warning have been met. Press the green check mark to start the reel calibration procedure. Pressing the red X will cancel the calibration procedure.



Figure 8.246: Reel Settings Calibration



Figure 8.247: Calibration Wizard

SETTING UP AUTO HEADER HEIGHT CONTROL SYSTEM

5. A message appears in the CALIBRATION WIZARD stating that the reel calibration procedure has started. The reel will begin turning slowly and its speed will gradually increase. If necessary, select the red X (not shown) to cancel the calibration procedure. Otherwise, wait for the message that the reel calibration procedure has completed successfully. Select the green check mark to save the calibrated settings.



Figure 8.248: Calibration Progress

Setting up Automatic Header Controls – IDEAL™ Series

To configure the automatic header height control (AHC) functions on an IDEAL™ Series combine to work with your header, navigate to the HEADER SETTINGS page on the combine's computer.

NOTE:

Changes may have been made to the combine controls or the display since this document was published. For the most up-to-date information, refer to the combine operator's manual.

1. **Automatic Control Functions:** There are toggle (OFF/ON) switches on the HEADER SETTINGS page for the automatic control functions. For MacDon headers, ensure that the following two functions are enabled as shown:

- RTC (return to cut) (A)
- AHC (automatic header height control) (B)

All other switches should be disabled (not highlighted).

2. **Sensitivity** setting (C) controls how responsive a control (RTC or AHC) is to a given change in sensor feedback. The setting fields are located directly below the toggle switches. To enter a new sensitivity setting, touch the setting field below the specific toggle switch, and enter the new value in the on-screen keyboard.

- Increase the sensitivity if the combine does not change the feeder position quickly enough when in Auto Mode.
- Decrease the sensitivity if the combine continually hunts for a position in Auto Mode.

NOTE:

The following sensitivity settings are recommended for MacDon headers:

- 50 for RTC (A)
- 60 for AHC (B)

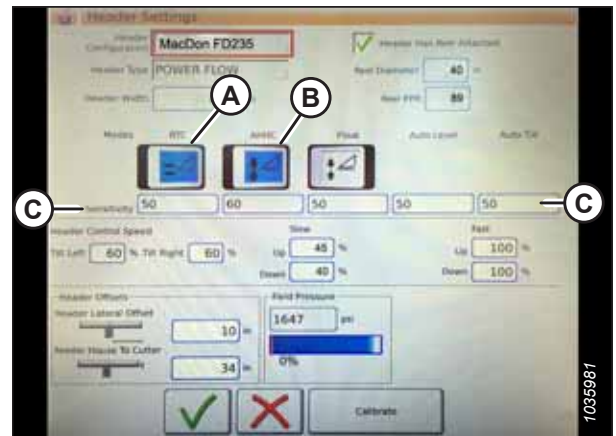

Figure 8.249: Automatic Controls and Sensitivity Settings

SETTING UP AUTO HEADER HEIGHT CONTROL SYSTEM

3. **Header Speed:** HEADER CONTROL SPEED area (A) on the HEADER SETTINGS page is used to adjust the following speeds:

- Tilt left and right is the lateral tilt of the combine faceplate.
- The header raise/lower function uses a two-detent button: the first detent is a slow raise/lower rate; the second detent is a fast raise/lower rate.

NOTE:

The recommended header control speed settings are:

- Slow: Up 45/Down 40
- Fast: Up 100/Down 100

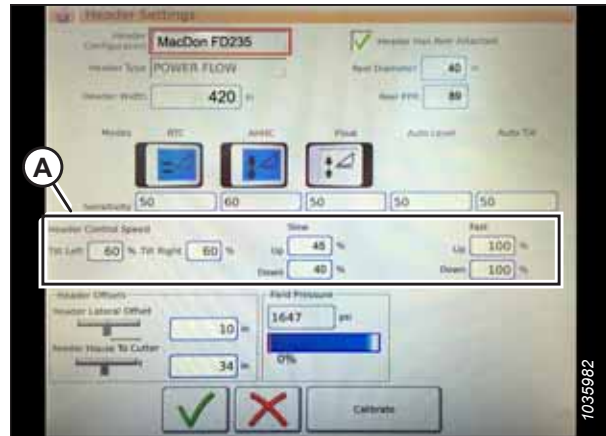

Figure 8.250: Header Speed Control Settings

4. **Header Offsets (A):** Offset distances are important for yield mapping. There are two adjustable dimensions on the HEADER SETTINGS page:

- **HEADER LATERAL OFFSET:** the distance between the centerline of the header and the centerline of the machine. This should be set at **0** for a MacDon header.
- **FEEDER HOUSE TO CUTTER:** the distance from the machine interface to the cutterbar. This should be set at **68** for a MacDon header.

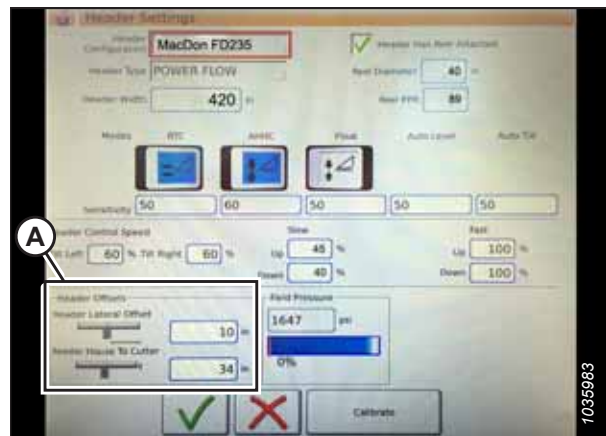

Figure 8.251: Header Offset Settings

Calibrating Header – IDEAL™ Series

The auto header height control (AHHC) sensor output must be calibrated for the combine.

DANGER

To prevent bodily injury or death from the unexpected start-up of the machine, always stop the engine and remove the key from the ignition before making adjustments to the machine.

DANGER

Ensure that all bystanders have cleared the area.

NOTE:

Changes may have been made to the combine controls or the display since this document was published. For the most up-to-date information, refer to the combine operator's manual.

NOTE:

If the header float is set too light, it can prevent the calibration of the AHHC. In order to prevent the header from separating from the float module, it may be necessary to change the float to a heavier setting during calibration.

SETTING UP AUTO HEADER HEIGHT CONTROL SYSTEM

1. Park the combine on a level surface.
2. Ensure that the header is level with the ground. If adjustment is required, refer to [10.5 Leveling Header, page 526](#).

NOTE:

Spirit level (A) is located on top of the float module frame. The header is level if the bubble is in the center of the spirit level.

3. Ensure that the center-link is set to **D**.

NOTE:

When calibration is complete, adjust the center-link back to the desired header angle. For instructions, refer to the header operator's manual.

4. Adjust the reel fore-aft position so that the indicator is at position **6**.
5. Position the header so that the cutterbar is 254–356 mm (10–14 in.) off the ground.
6. Shut down the engine, and remove the key from the ignition.



CAUTION

To prevent cuts, pinches, and other bodily harm to the person checking the down stops, ensure that nobody is manually lifting, bouncing, or moving the header in any way while the down stop washer is being touched and checked for movement.

7. Ensure that the float lock linkage is on the down stops (washer [A] cannot move) at both locations.

NOTE:

If the header is **NOT** on the down stops, the voltage may go out of range during operation and cause the AHHC system to malfunction. To fix the problem, make the header heavier by decreasing the float. For instructions, refer to [6.10 Checking and Adjusting Header Float, page 229](#).

8. Unlock the header float. For instructions, refer to the header operator's manual.

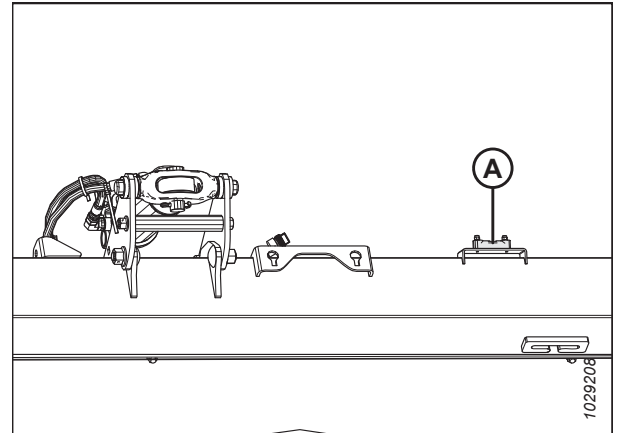

Figure 8.252: Spirit Level

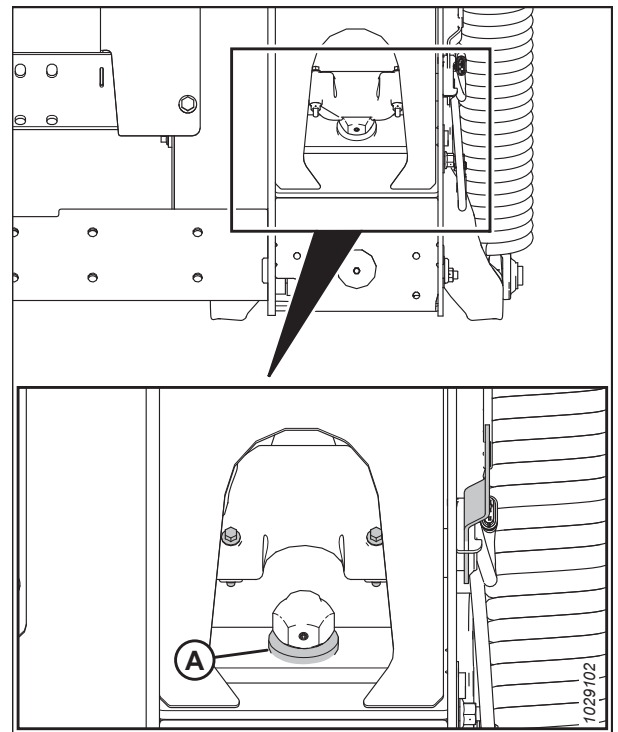

Figure 8.253: Down Stop Washer

SETTING UP AUTO HEADER HEIGHT CONTROL SYSTEM

- On the COMBINE MAIN MENU, select HEADER SETTINGS icon (A).

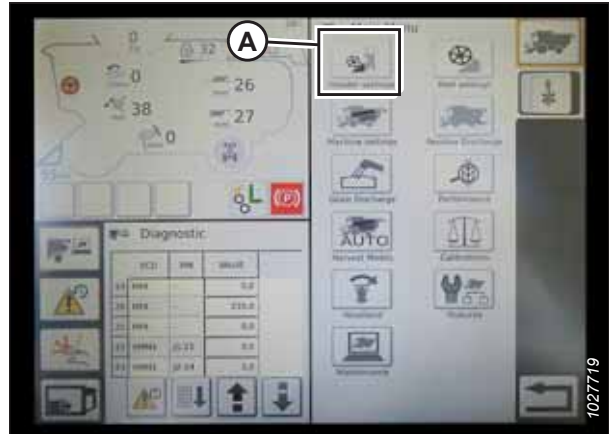

Figure 8.254: Combine Main Menu

- Select HEADER CALIBRATION icon (A) beside the HEADER SETTINGS CONFIG page.

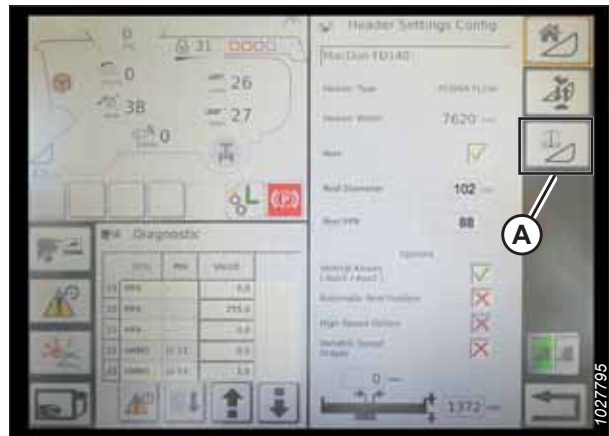

Figure 8.255: Header Settings Page

- The hazard warning for HEADER CALIBRATION appears. Ensure that all conditions are met.
- Select the green check mark at the bottom of the page to start the calibration procedure and follow the on-screen commands.



Figure 8.256: Header Calibration Warning

SETTING UP AUTO HEADER HEIGHT CONTROL SYSTEM

A progress bar is provided; the calibration process can be stopped by selecting the red X. The header moves automatically and erratically during this process.

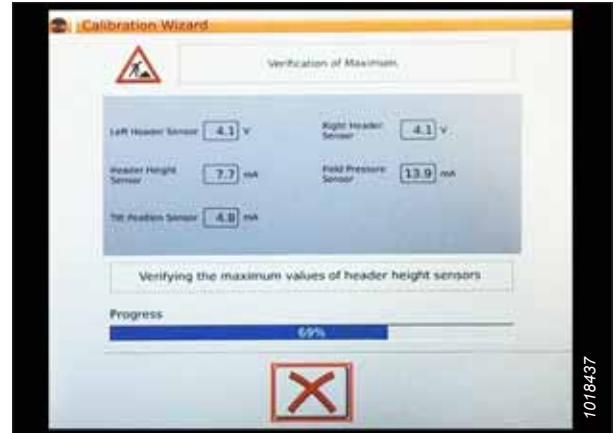

Figure 8.257: Calibration in Progress

13. When the calibration procedure is complete:

- Review summary information (A)
- Ensure that green check marks confirm calibrated functions (B)
- Select check mark (C) to save the calibrated settings

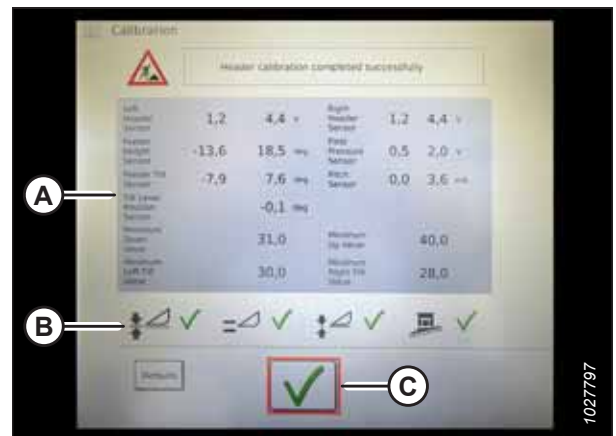

Figure 8.258: Completed Calibration Page

NOTE:

Select CALIBRATIONS icon (A) on the MAIN MENU page to display the CALIBRATION MENU where you can choose from a variety of calibrations including header and reel calibration.

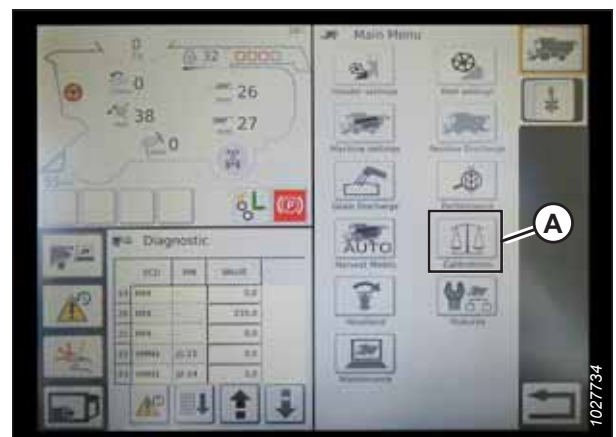

Figure 8.259: Direct Calibration Menu

SETTING UP AUTO HEADER HEIGHT CONTROL SYSTEM

Operating Header – IDEAL™ Series

Once the auto header height control (AHHC) system has been configured on your IDEAL™ Series combine, you can control the AHHC system from the combine cab.

NOTE:

Changes may have been made to the combine controls or the display since this document was published. For the most up-to-date information, refer to the combine operator's manual.

The following are used to operate the AHHC functions:

- Tyton terminal (A)
- Control handle (B)
- Throttle (C)
- Header control cluster (D)

Refer to the combine operator's manual to familiarize yourself with the combine's controls.



Figure 8.260: Operator's Station

1. With the header running, set the lateral tilt to MANUAL by pressing switch (A). The light above switch (A) should be off.
2. Engage the AHHC by pressing switch (B). The light above switch (B) should be on.



Figure 8.261: Header Control Cluster

SETTING UP AUTO HEADER HEIGHT CONTROL SYSTEM

3. Press AHHC control switch (A) on the control handle to engage the AHHC. The header moves to the configured set point position.



Figure 8.262: AHHC on Control Handle

4. Use HEADER HEIGHT SETPOINT control dial (A) as necessary to fine-tune the header position.



Figure 8.263: Header Control Cluster

Reviewing Header In-Field Settings – IDEAL™ Series

Once the auto header height control (AHHC) system is working correctly with your IDEAL™ Series combine, you can fine-tune these AHHC settings to your liking.

NOTE:

Changes may have been made to the combine controls or the display since this document was published. For the most up-to-date information, refer to the combine operator's manual.

SETTING UP AUTO HEADER HEIGHT CONTROL SYSTEM

1. Select HEADER icon (A) on the right side of the home page to view the following header group settings:
 - CURRENT POSITION of header (B).
 - SETPOINT cut-off position (C) (indicated by the red line)
 - HEADER symbol (D) – select this to adjust the set point cut-off position using the adjustment wheel on the right side of the Tyton terminal.
 - CUT HEIGHT for AHHC (E) – fine-tune this setting with the header height set point control dial on the header control cluster.
 - HEADER WORKING WIDTH (F)
 - HEADER PITCH (G)

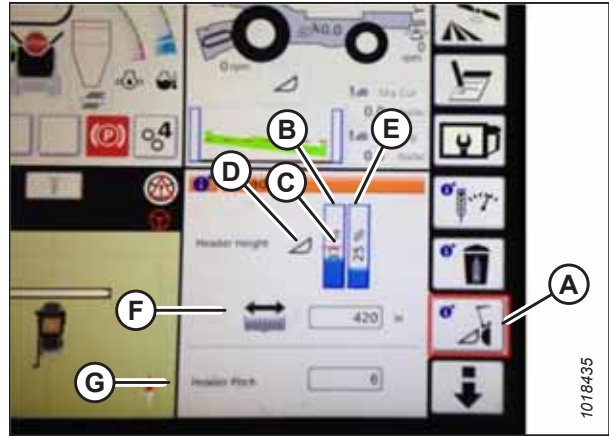

Figure 8.264: Header Groups

2. Selecting a field opens the on-screen keyboard so that the values can be adjusted. Enter the new value and touch the green check mark.

NOTE:

Adjustment wheel (A) is located on the right of the Tyton terminal.

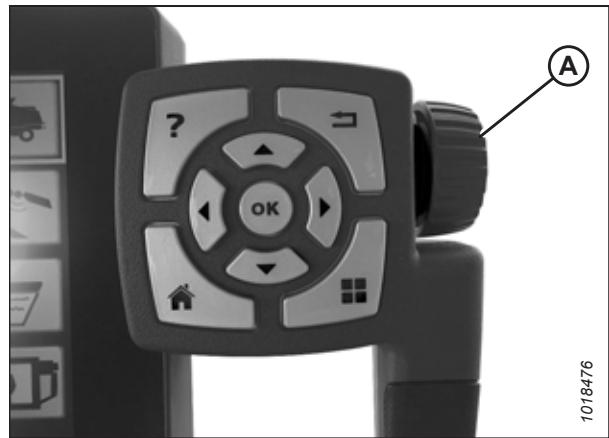

Figure 8.265: Adjustment Wheel on Right of Tyton Terminal

NOTE:

HEADER HEIGHT SETPOINT control dial (A) is on the header control cluster.



Figure 8.266: Header Control Cluster

8.1.14 John Deere 60 Series Combines

Follow these steps to set up auto header height control (AHHC) on John Deere 60 series combines.

Checking Voltage Range from Combine Cab – John Deere 60 Series

The auto header height control (AHHC) sensor needs to operate in a specific voltage range in order to work properly.

NOTE:

Changes may have been made to the combine controls or the display since this document was published. For the most up-to-date information, refer to the combine operator's manual.

⚠ DANGER

To prevent bodily injury or death from the unexpected start-up of the machine, always stop the engine and remove the key from the ignition before making adjustments to the machine.

⚠ DANGER

Ensure that all bystanders have cleared the area.

1. Position the header so that the cutterbar is 254–356 mm (10–14 in.) off the ground.
2. Shut down the engine, and remove the key from the ignition.
3. Unlock the header float. For instructions, refer to the header operator's manual.

⚠ CAUTION

To prevent cuts, pinches, and other bodily harm to the person checking the down stops, ensure that nobody is manually lifting, bouncing, or moving the header in any way while the down stop washer is being touched and checked for movement.

4. Ensure that the float lock linkage is on the down stops (washer [A] cannot move) at both locations.

NOTE:

If the header is **NOT** on the down stops, the voltage may go out of range during operation and cause the AHHC system to malfunction. To fix the problem, make the header heavier by decreasing the float. For instructions, refer to [6.10 Checking and Adjusting Header Float, page 229](#).

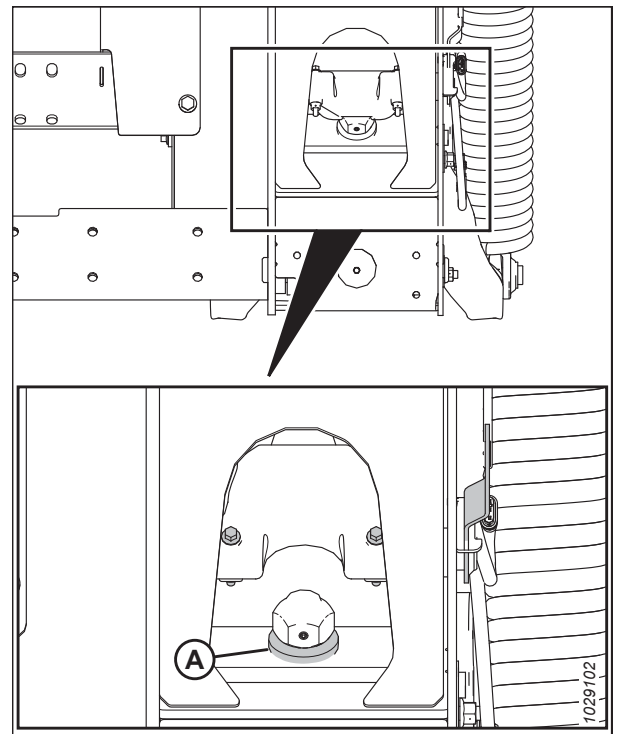

Figure 8.267: Down Stop Washer

SETTING UP AUTO HEADER HEIGHT CONTROL SYSTEM

- If the pointer is not on zero, loosen bolt (A) and slide float indicator plate (B) until pointer (C) is on 0 (D). Tighten the nut on bolt (A).

NOTE:

Use zero dot (E) above the decal to correctly set the indicator needle.

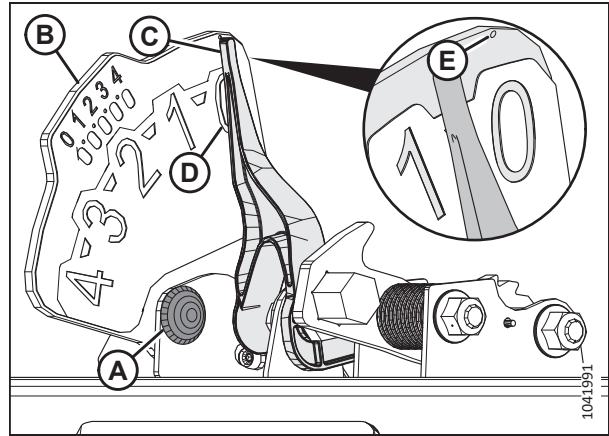

Figure 8.268: Float Indicator

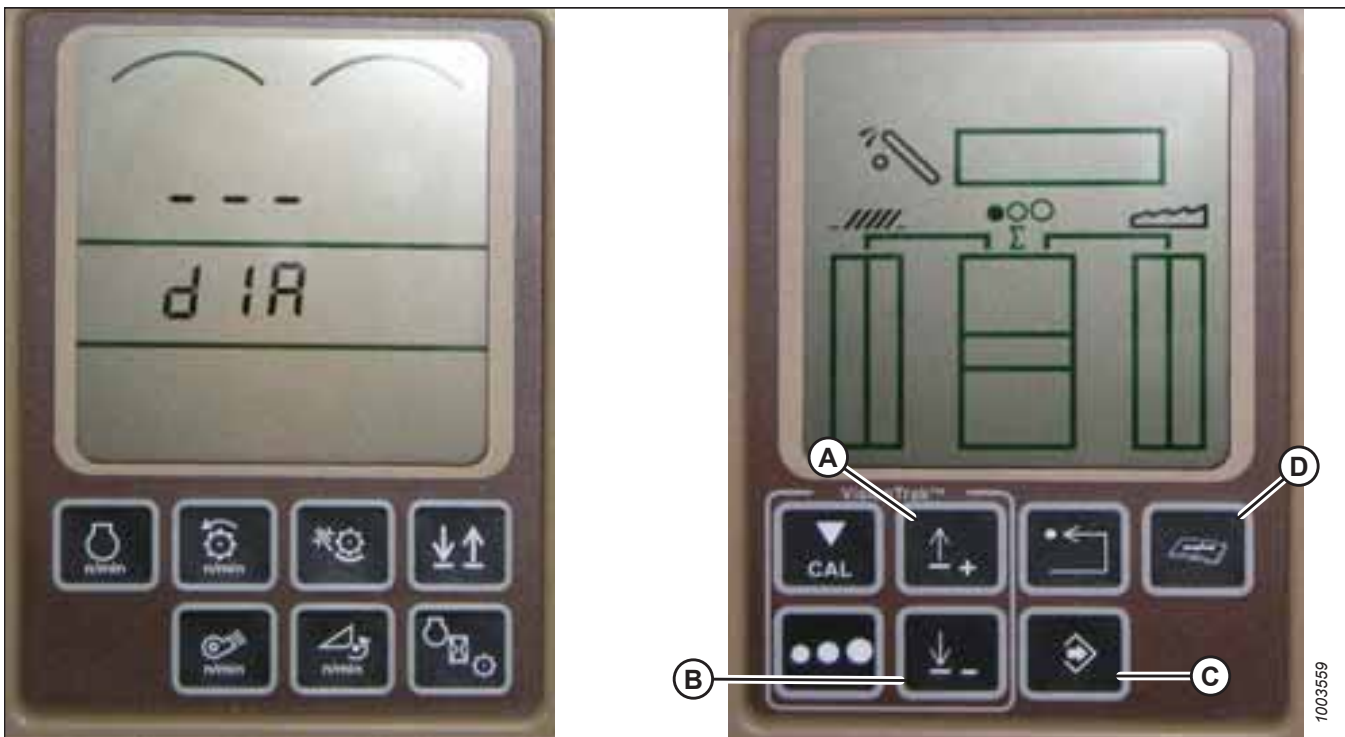

Figure 8.269: John Deere Combine Display

- Press DIAGNOSTIC button (D) on the display—DIA appears on the display.
- Press UP button (A) until EO1 appears on the display—this is the header adjustments.
- Press ENTER button (C).
- Press the UP (A) or DOWN button (B) until 24 is shown on the top portion of the display—this is the voltage reading for the sensor.
- Ensure the header float is unlocked.
- Start the combine, and fully lower the feeder house to the ground.

NOTE:

You may need to hold the HEADER DOWN switch for a few seconds to ensure the feeder house is fully lowered.

SETTING UP AUTO HEADER HEIGHT CONTROL SYSTEM

12. Check the sensor reading on the display. The reading should be above 0.5 V.
13. Raise the header so it is just off the ground. The reading on the display should read below 4.5 V.
14. If the sensor voltage is not within the lower and upper limits, or if the range between the lower and upper limits is insufficient, refer to [8.1.3 Manually Checking Voltage Limits, page 269](#).

Calibrating Auto Header Height Control – John Deere 60 Series

The auto header height control (AHHC) sensor output must be calibrated for each combine, or the AHHC feature will not work properly.

DANGER

To prevent bodily injury or death from the unexpected start-up of the machine, always stop the engine and remove the key from the ignition before making adjustments to the machine.

DANGER

Ensure that all bystanders have cleared the area.

NOTE:

Changes may have been made to the combine controls or the display since this document was published. For the most up-to-date information, refer to the combine operator's manual.

NOTE:

If the header float is set too light, it can prevent the calibration of the AHHC. In order to prevent the header from separating from the float module, it may be necessary to change the float to a heavier setting during calibration.

1. Park the combine on a level surface.
2. Ensure that the header is level with the ground. If adjustment is required, refer to [10.5 Leveling Header, page 526](#).

NOTE:

Spirit level (A) is located on top of the float module frame. The header is level if the bubble is in the center of the spirit level.

3. Ensure that the center-link is set to **D**.

NOTE:

When calibration is complete, adjust the center-link back to the desired header angle. For instructions, refer to the header operator's manual.

4. Adjust the reel fore-aft position so that the indicator is at position **6**.
5. Position the header so that the cutterbar is 254–356 mm (10–14 in.) off the ground.
6. Shut down the engine, and remove the key from the ignition.

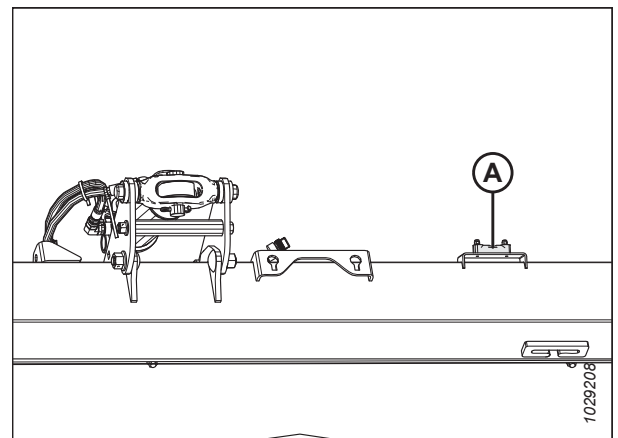

Figure 8.270: Spirit Level

SETTING UP AUTO HEADER HEIGHT CONTROL SYSTEM

CAUTION

To prevent cuts, pinches, and other bodily harm to the person checking the down stops, ensure that nobody is manually lifting, bouncing, or moving the header in any way while the down stop washer is being touched and checked for movement.

7. Ensure that the float lock linkage is on the down stops (washer [A] cannot move) at both locations.

NOTE:

If the header is **NOT** on the down stops, the voltage may go out of range during operation and cause the AHHC system to malfunction. To fix the problem, make the header heavier by decreasing the float. For instructions, refer to [6.10 Checking and Adjusting Header Float, page 229](#).

8. Unlock the header float. For instructions, refer to the header operator's manual.

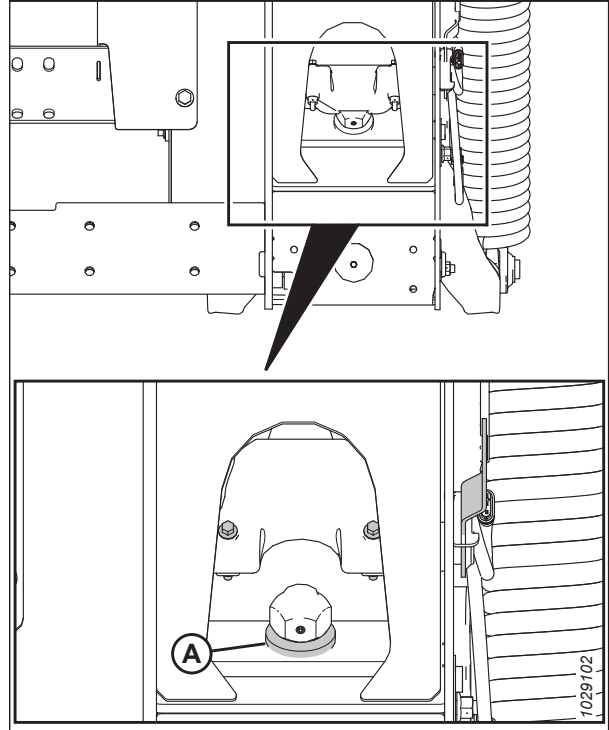

Figure 8.271: Down Stop Washer

9. Press DIAGNOSTIC button (A) on the display. DIA appears on the display.
10. Press CAL button (B). DIA-CAL appears on the display.

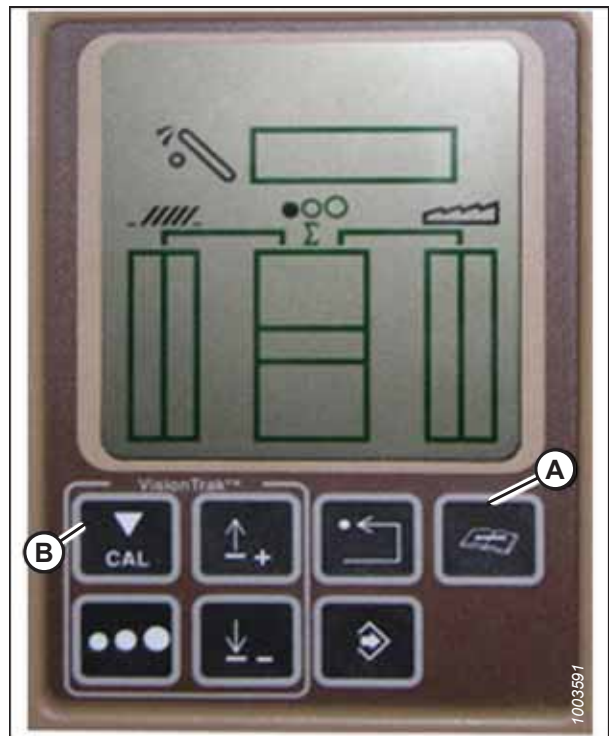

Figure 8.272: John Deere Combine Display

SETTING UP AUTO HEADER HEIGHT CONTROL SYSTEM

11. Press the UP or DOWN buttons until HDR appears on the display.
12. Press the ENTER button. HDR H-DN appears on the display.
13. Fully lower the feeder house to the ground.

NOTE:

You may need to hold the HEADER DOWN switch for a few seconds to ensure the feeder house is fully lowered.

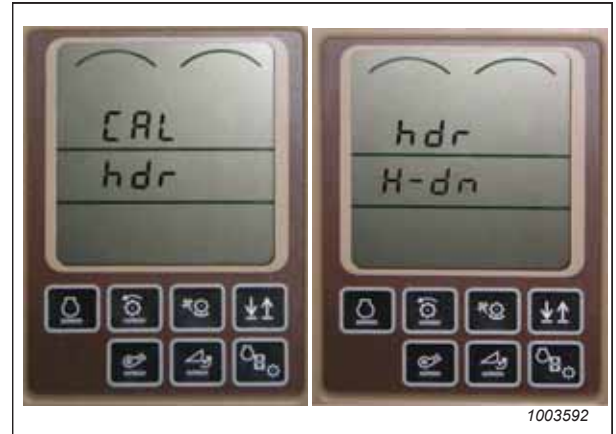

Figure 8.273: John Deere Combine Display

14. Press CAL button (A) to save the calibration of the header. HDR H-UP appears on the display.
15. Raise the header 1 m (3 ft.) off the ground and press CAL button (A). EOC appears on the display.
16. Press ENTER button (B) to save the calibration of the header. The AHHC is now calibrated.

NOTE:

If an error code appears during calibration, the sensor is out of voltage range and will require adjustment. For instructions, refer to [Checking Voltage Range from Combine Cab – John Deere 60 Series, page 395](#).

NOTE:

After the calibration is complete, adjust the combine operation settings to ensure proper field operation.

NOTE:

If the float was set heavier to complete the AHHC calibration procedure, adjust it to the recommended operating float after the calibration is complete.

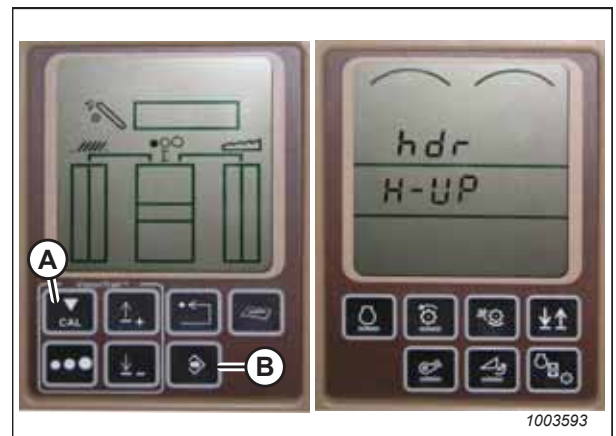

Figure 8.274: John Deere Combine Display

Turning Accumulator Off – John Deere 60 Series

The accumulator prevents shocks to the hydraulic system when the combine is operating with a heavy header attached. The accumulator should not be used when operating the combine with a header that has a float module attached.



DANGER

Ensure that all bystanders have cleared the area.

NOTE:

Changes may have been made to the combine controls or the display since this document was published. For the most up-to-date information, refer to the combine operator's manual.

SETTING UP AUTO HEADER HEIGHT CONTROL SYSTEM

1. Press DIAGNOSTIC button (A) on the display. DIA appears on the display.
2. Press UP button (B) until EO1 appears on the display, and press ENTER (D). This is the header adjustment.
3. Press UP (B) or DOWN (C) button until 132 is displayed on the top portion of the display. This is the reading for the accumulator.
4. Press ENTER (D) to select 132 as the accumulator reading (this will allow you to change the display to a three-digit number so it has a 0 in it, for example, x0x).
5. Press UP (B) or DOWN (C) button until the desired number is displayed, and press CAL button (E).
6. Press ENTER (D) to save the changes. The accumulator is now deactivated.

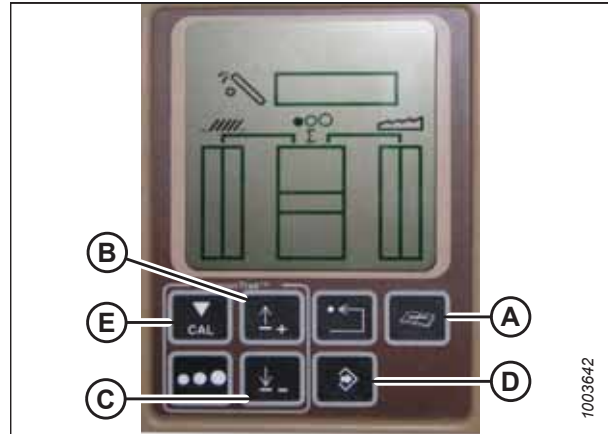

Figure 8.275: John Deere Combine Display

Setting Header Height Sensitivity – John Deere 60 Series

In order for a John Deere 60 Series combine to accurately read the output from the height sensors on a MacDon header, the combine's sensitivity setting needs to be set to 50.

DANGER

Ensure that all bystanders have cleared the area.

NOTE:

Changes may have been made to the combine controls or the display since this document was published. For the most up-to-date information, refer to the combine operator's manual.

1. Press DIAGNOSTIC button (A) on the display. DIA appears on the display.
2. Press UP button (B) until EO1 appears on the display, and press ENTER (D). This is the header adjustment.
3. Press UP (B) or DOWN (C) button until 128 is shown on the top portion of the display. This is the reading for the sensor.
4. Press ENTER (D) to select 128 as the sensor reading (this will allow you to change the display to a three-digit number so it has a 50 in it).
5. Press UP (B) or DOWN (C) button until the desired number is displayed, and press CAL button (E).
6. Press ENTER (D) to save the changes. The height is now set.

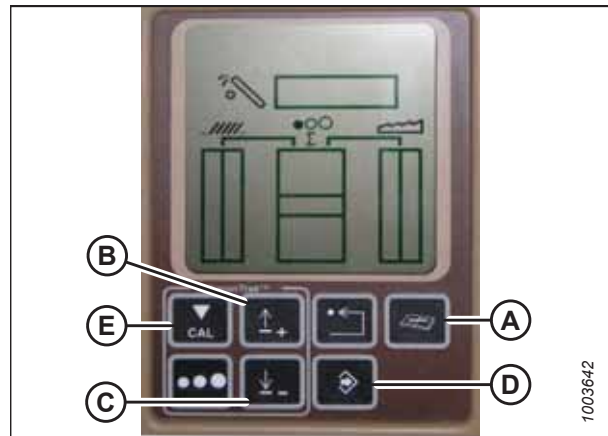

Figure 8.276: John Deere Combine Display

SETTING UP AUTO HEADER HEIGHT CONTROL SYSTEM

NOTE:

Do **NOT** use active header float function (A) in combination with the MacDon auto header height control (AHHC)—the two systems will counteract one another. Header symbol (B) on the display should **NOT** have a wavy line under it and should appear exactly as shown on the Active Header Control Display in Figure 8.277, page 401.

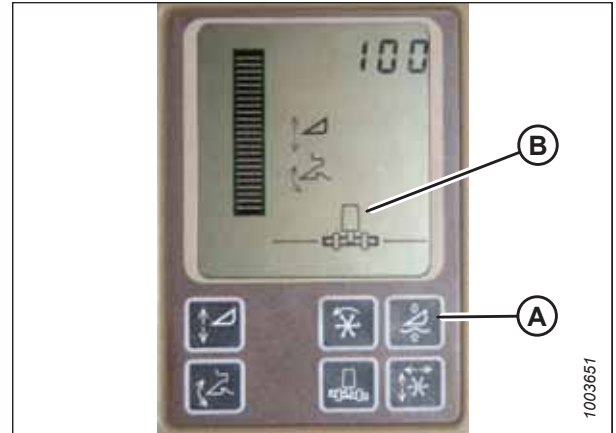

Figure 8.277: John Deere Combine Display

Setting Auto Header Height Control Sensitivity – John Deere 60 Series

The sensitivity adjustment controls the distance the cutterbar must travel up or down before the auto header height control (AHHC) reacts and raises or lowers the feeder house.

DANGER

Ensure that all bystanders have cleared the area.

When the sensitivity is set to maximum, only small changes in ground height are needed to cause the feeder house to raise or lower. When the sensitivity is set to minimum, large changes in the ground height are needed to cause the feeder house to raise or lower.

NOTE:

Changes may have been made to the combine controls or the display since this document was published. For the most up-to-date information, refer to the combine operator's manual.

NOTE:

The numbers shown on the displays in these illustrations are for reference purposes only; they are not intended to represent the specific settings for your equipment.

1. Press DIAGNOSTIC button (A) on the display. DIA appears on the display.
2. Press UP button (B) until EO1 appears on the display, and press ENTER (D). This is the header adjustment.
3. Press UP (B) or DOWN (C) button until 112 is shown on the display. This is your sensitivity setting.

NOTE:

The lower the reading, the higher the sensitivity. Ideal operating range is typically between 50 and 80.

4. Press ENTER (D) to select 112 as the sensitivity setting (this will allow you to change the first digit of the number sequence).

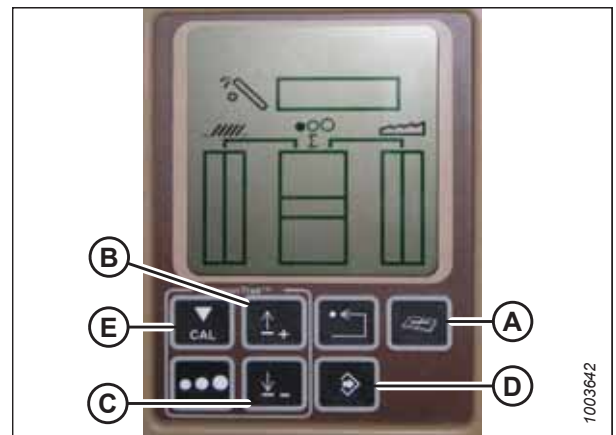

Figure 8.278: John Deere Combine Display

SETTING UP AUTO HEADER HEIGHT CONTROL SYSTEM

5. Press UP (B) or DOWN (C) until the desired number is displayed, then press CAL button (E). This will bring you to the second digit. Repeat this procedure until the desired setting is achieved.
6. Press ENTER (D) to save changes.

Adjusting Drop Rate Valve Threshold – John Deere 60 Series

This procedure details how to adjust the point at which the restrictor valve opens to allow full flow to the lift cylinders.

DANGER

Ensure that all bystanders have cleared the area.

NOTE:

Changes may have been made to the combine controls or the display since this document was published. For the most up-to-date information, refer to the combine operator's manual.

NOTE:

The numbers shown on the displays in these illustrations are for reference purposes only; they are not intended to represent the specific settings for your equipment.

1. Press DIAGNOSTIC button (A) on the display. DIA appears on the display.
2. Press UP button (B) until EO1 appears on the display and press ENTER (C). This is the header adjustment.
3. Press UP (B) or DOWN button until 114 is shown on the top portion of the display. This is the setting that adjusts when the fast drop rate starts with respect to the dead band.

NOTE:

The default setting is 100. The ideal operating range is typically between 60 and 85.

4. Press ENTER (C) to select 114 as the fast drop rate (this will allow you to change the first digit of the number sequence).
5. Press UP (A) or DOWN (B) until the desired number is displayed, then press CAL button (C). This will bring you to the second digit. Repeat this procedure until the desired setting is achieved.
6. Press ENTER (D) to save changes.

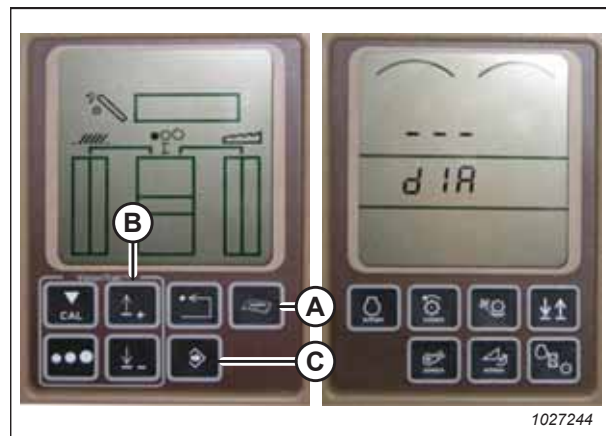

Figure 8.279: John Deere Combine Display

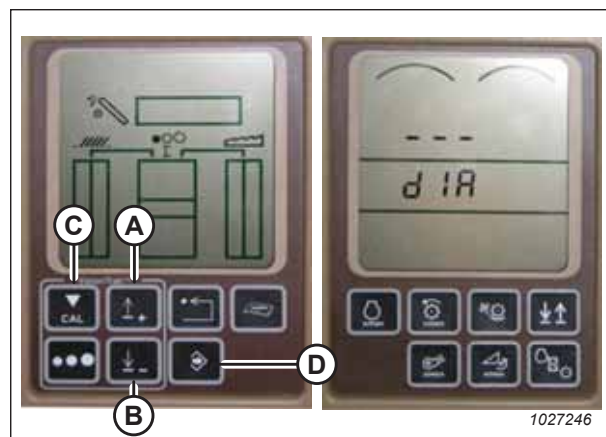

Figure 8.280: John Deere Combine Display

8.1.15 John Deere 70 Series Combines

To make your header's auto header height control (AHHC) system compatible with the combine, you must set your combine's header configuration options for the particular model of header, configure the reel speed settings, set up the AHHC controls, and calibrate the AHHC system to ensure that it is working correctly.

Checking Voltage Range from Combine Cab – John Deere 70 Series

The auto header height control (AHHC) sensor needs to operate in a specific voltage range in order to work properly.

NOTE:

Changes may have been made to the combine controls or the display since this document was published. For the most up-to-date information, refer to the combine operator's manual.

⚠ DANGER

To prevent bodily injury or death from the unexpected start-up of the machine, always stop the engine and remove the key from the ignition before making adjustments to the machine.

⚠ DANGER

Ensure that all bystanders have cleared the area.

1. Position the header so that the cutterbar is 254–356 mm (10–14 in.) off the ground.
2. Shut down the engine, and remove the key from the ignition.
3. Unlock the header float. For instructions, refer to the header operator's manual.

⚠ CAUTION

To prevent cuts, pinches, and other bodily harm to the person checking the down stops, ensure that nobody is manually lifting, bouncing, or moving the header in any way while the down stop washer is being touched and checked for movement.

4. Ensure that the float lock linkage is on the down stops (washer [A] cannot move) at both locations.

NOTE:

If the header is **NOT** on the down stops, the voltage may go out of range during operation and cause the AHHC system to malfunction. To fix the problem, make the header heavier by decreasing the float. For instructions, refer to [6.10 Checking and Adjusting Header Float, page 229](#).

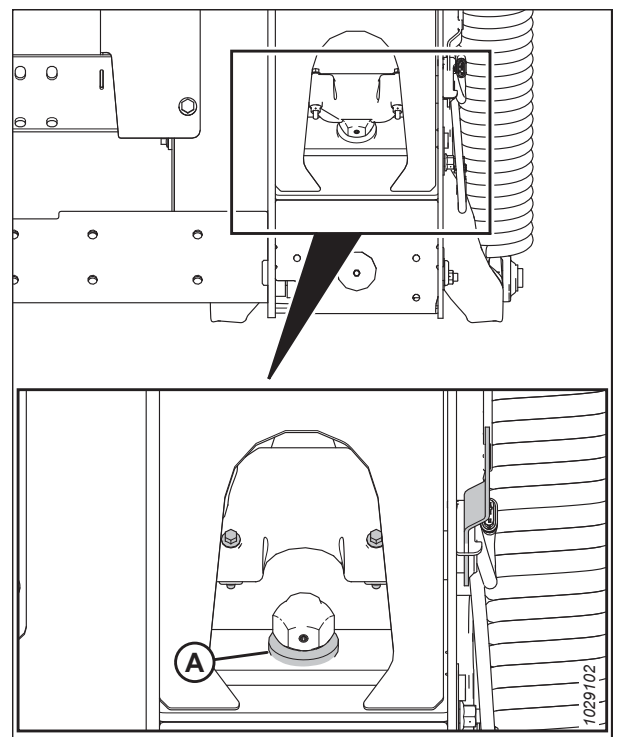

Figure 8.281: Down Stop Washer

SETTING UP AUTO HEADER HEIGHT CONTROL SYSTEM

- If the pointer is not on zero, loosen bolt (A) and slide float indicator plate (B) until pointer (C) is on 0 (D). Tighten the nut on bolt (A).

NOTE:

Use zero dot (E) above the decal to correctly set the indicator needle.

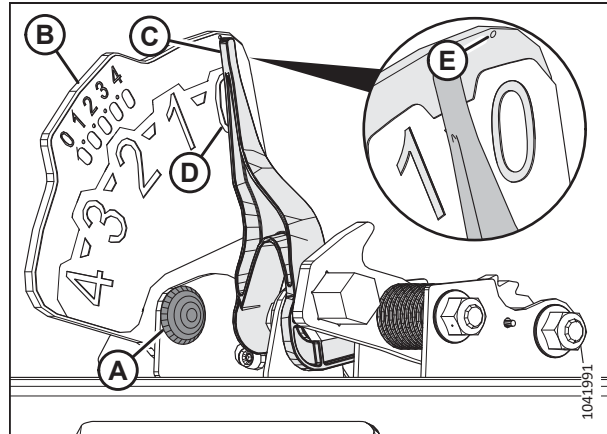

Figure 8.282: Float Indicator

- Press HOME PAGE button (A) on the main page of the display.



Figure 8.283: John Deere Combine Display

- Ensure that three icons (A) appear on the display.



Figure 8.284: John Deere Combine Display

SETTING UP AUTO HEADER HEIGHT CONTROL SYSTEM

- Use scroll knob (A) to highlight the middle icon (the green i) and press check mark button (B) to select it. The MESSAGE CENTER appears.

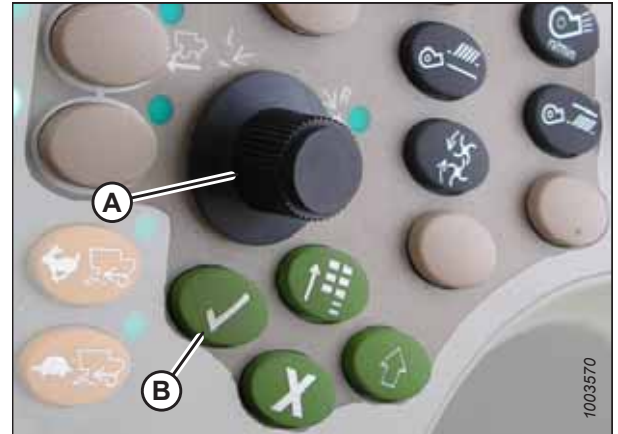

Figure 8.285: John Deere Combine Control Console

- Use the scroll knob to highlight DIAGNOSTIC ADDRESSES (A) from the right column. Select it by pressing the check mark button.
- Use the scroll knob to highlight drop-down box (B). Press the check mark button to select it.

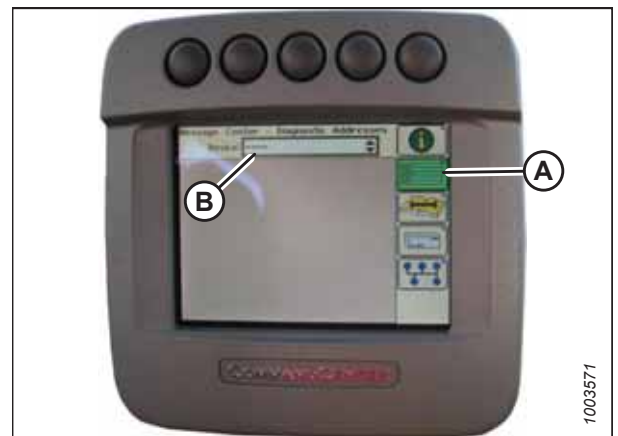

Figure 8.286: John Deere Combine Display

- Use the scroll knob to highlight LC 1.001 VEHICLE (A). Press the check mark button to select it.



Figure 8.287: John Deere Combine Display

SETTING UP AUTO HEADER HEIGHT CONTROL SYSTEM

- Use the scroll knob to highlight down arrow (A). Press the check mark button to scroll through the list until 029 DATA (B) appears and voltage reading (C) appears on the display.
- Ensure that the header float is unlocked.
- Start the engine.

NOTE:

You may need to hold the HEADER DOWN switch for a few seconds to ensure that the feeder house is fully lowered.

- Fully lower the feeder house to the ground.

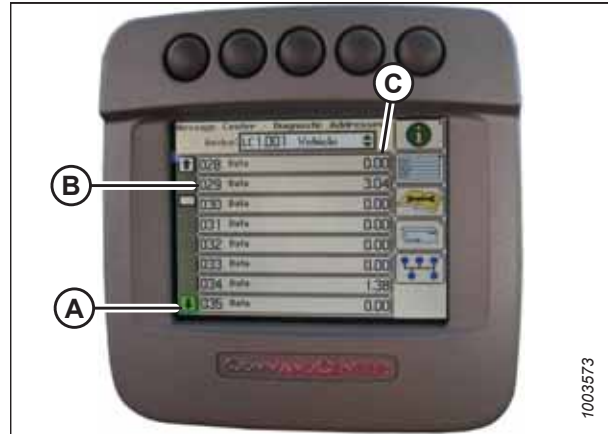

Figure 8.288: John Deere Combine Display

- Check the voltage reading on the display. For information on the appropriate voltage range, refer to [8.1.2 Recommended Sensor Output Voltages for Combines](#), page 268.
- Raise the header so that it is just off the ground and recheck the sensor reading.
- If the sensor voltage is not within the lower and upper limits, or if the range between the lower and upper limits is insufficient, refer to [8.1.3 Manually Checking Voltage Limits](#), page 269.

Calibrating Feeder House Speed – John Deere 70 Series

The feeder house speed must be calibrated before calibrating the auto header height control (AHHC) system. For instructions, refer to the combine operator's manual.

Adjusting Manual Header Raise/Lower Rate – John Deere 70 Series

The rate at which the header can be raised or lowered using the controls in the combine cab can be adjusted using the combine console.

NOTE:

Changes may have been made to the combine controls or the display since this document was published. For the most up-to-date information, refer to the combine operator's manual.

- Press button (A) and the current raise/lower rate setting will appear on the display (the lower the reading, the slower the speed at which the header moves).
- Use scroll knob (B) to adjust the rate. The adjustment will be saved automatically.

NOTE:

If the display remains idle for a short period of time, it will automatically return to the previous page. Pressing check mark button (C) will also return the display to the previous page.

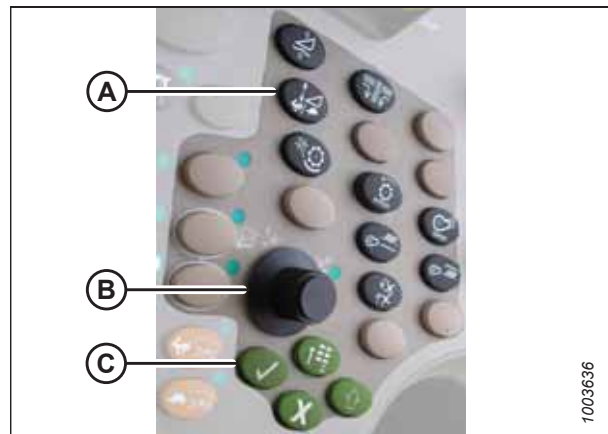

Figure 8.289: John Deere Combine Control Console

SETTING UP AUTO HEADER HEIGHT CONTROL SYSTEM

NOTE:

The numbers shown on the displays in these illustrations are for reference purposes only; they are not intended to represent the specific settings for your equipment.



Figure 8.290: John Deere Combine Display

Calibrating Auto Header Height Control – John Deere 70 Series

The auto header height control (AHHC) sensor output must be calibrated for each combine.

DANGER

To prevent bodily injury or death from the unexpected start-up of the machine, always stop the engine and remove the key from the ignition before making adjustments to the machine.

DANGER

Ensure that all bystanders have cleared the area.

NOTE:

Changes may have been made to the combine controls or the display since this document was published. For the most up-to-date information, refer to the combine operator's manual.

NOTE:

If the header float is set too light, it can prevent the calibration of the AHHC. In order to prevent the header from separating from the float module, it may be necessary to change the float to a heavier setting during calibration.

1. Park the combine on a level surface.
2. Ensure that the header is level with the ground. If adjustment is required, refer to [10.5 Leveling Header, page 526](#).

NOTE:

Spirit level (A) is located on top of the float module frame. The header is level if the bubble is in the center of the spirit level.

3. Ensure that the center-link is set to **D**.

NOTE:

When calibration is complete, adjust the center-link back to the desired header angle. For instructions, refer to the header operator's manual.

4. Adjust the reel fore-aft position so that the indicator is at position **6**.

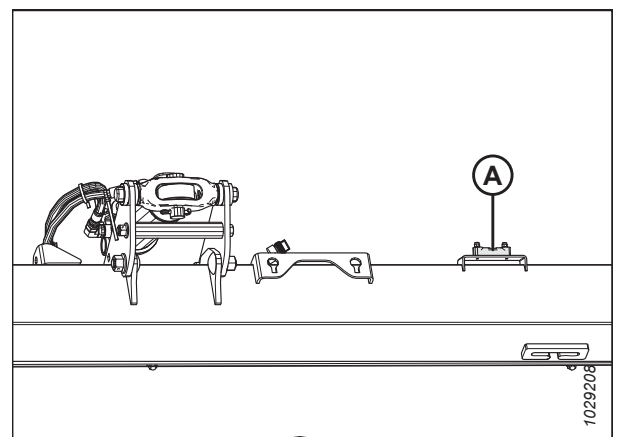

Figure 8.291: Spirit Level

SETTING UP AUTO HEADER HEIGHT CONTROL SYSTEM

5. Position the header so that the cutterbar is 254–356 mm (10–14 in.) off the ground.
6. Shut down the engine, and remove the key from the ignition.

CAUTION

To prevent cuts, pinches, and other bodily harm to the person checking the down stops, ensure that nobody is manually lifting, bouncing, or moving the header in any way while the down stop washer is being touched and checked for movement.

7. Ensure that the float lock linkage is on the down stops (washer [A] cannot move) at both locations.

NOTE:

If the header is **NOT** on the down stops, the voltage may go out of range during operation and cause the AHHC system to malfunction. To fix the problem, make the header heavier by decreasing the float. For instructions, refer to [6.10 Checking and Adjusting Header Float, page 229](#).

8. Unlock the header float. For instructions, refer to the header operator's manual.

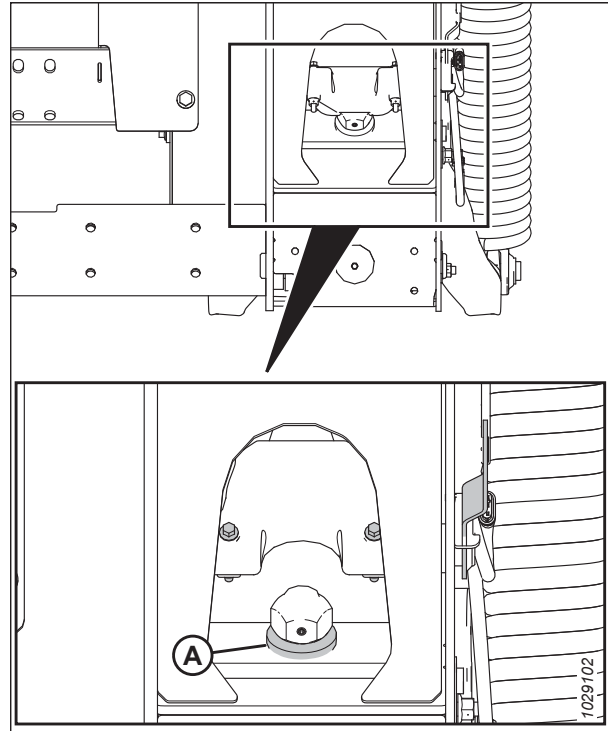

Figure 8.292: Down Stop Washer

9. Press button (A) to select icon (B).
10. Press button (A) a second time to enter diagnostics and calibration mode.

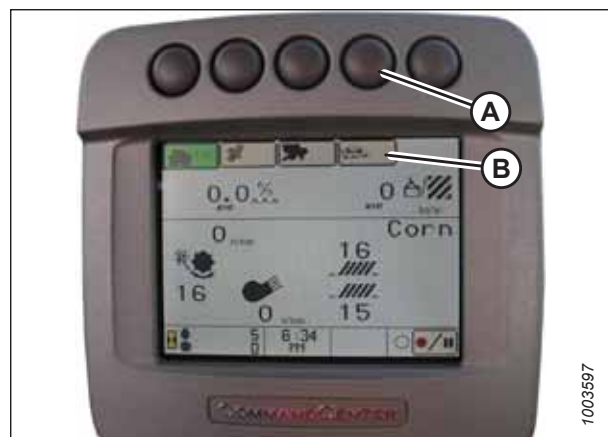

Figure 8.293: John Deere Combine Display

SETTING UP AUTO HEADER HEIGHT CONTROL SYSTEM

11. Select HEADER in box (A) by scrolling down to the box using the scroll knob, then pressing the check mark button.

NOTE:

The knob and button are shown in Figure 8.295, page 409.

12. Scroll down to lower right icon (B) and press the check mark button to select it.
13. Follow the steps listed on the page to perform the calibration.

NOTE:

If an error code appears on the display, the sensor is not in the correct working range. Check and adjust the range. For instructions, refer to *Checking Voltage Range from Combine Cab – John Deere S and T Series*, page 410.

14. If the float was set heavier to complete the AHHC calibration procedure, adjust it to the recommended operating float after the calibration is complete.

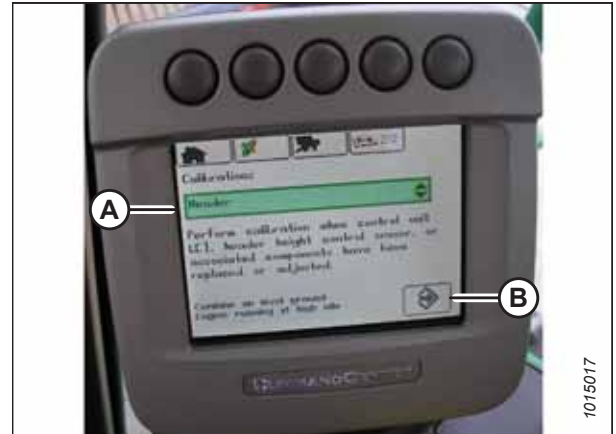

Figure 8.294: John Deere Combine Display

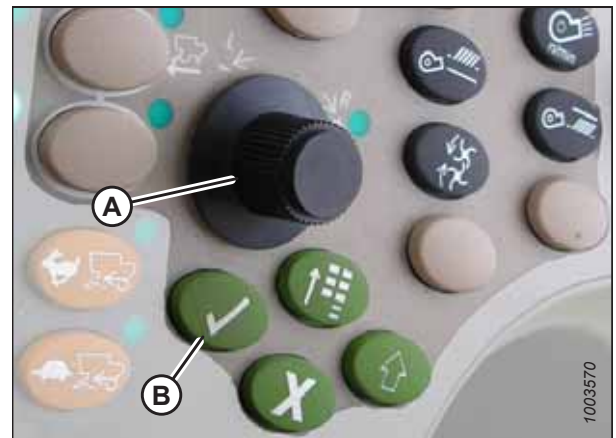

Figure 8.295: John Deere Combine Control Console

A - Scroll Knob

B - Check Mark Button

Setting Auto Header Height Control Sensitivity – John Deere 70 Series

The sensitivity adjustment controls the distance the cutterbar must travel up or down before the auto header height control (AHHC) reacts and raises or lowers the feeder house.

When the sensitivity is set to maximum, only small changes in ground height are needed to cause the feeder house to raise or lower. When the sensitivity is set to minimum, large changes in the ground height are needed to cause the feeder house to raise or lower.

NOTE:

Changes may have been made to the combine controls or the display since this document was published. For the most up-to-date information, refer to the combine operator's manual.

SETTING UP AUTO HEADER HEIGHT CONTROL SYSTEM

1. Press button (A) twice. The current sensitivity setting will appear on the display.
2. Use scroll knob (B) to adjust the sensitivity setting. The adjustment will be saved automatically.

NOTE:

If the page remains idle for a short period of time, it will automatically return to the previous page. Pressing green check mark button (C) also will return the display to the previous page.

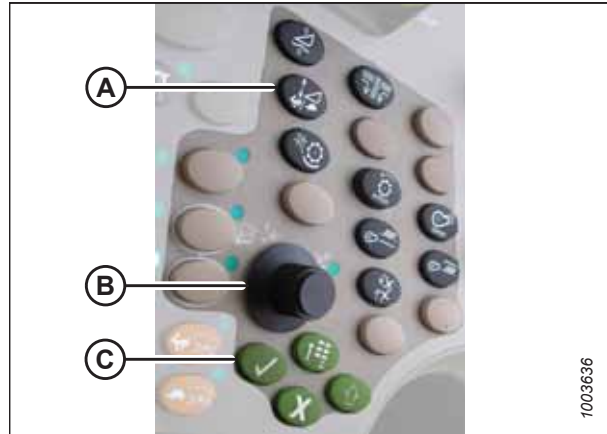

Figure 8.296: John Deere Combine Control Console

NOTE:

The numbers shown on the displays in these illustrations are for reference purposes only; they are not intended to represent the specific settings for your equipment.



Figure 8.297: John Deere Combine Display

8.1.16 John Deere S and T Series Combines

To make your header's auto header height control (AHHC) system compatible with the combine, you must set your combine's header configuration options for the particular model of header, configure the reel speed settings, set up the AHHC controls, and calibrate the AHHC system to ensure that it is working correctly.

Checking Voltage Range from Combine Cab – John Deere S and T Series

The auto header height control (AHHC) sensor needs to operate in a specific voltage range in order to work properly.

NOTE:

Changes may have been made to the combine controls or the display since this document was published. For the most up-to-date information, refer to the combine operator's manual.

DANGER

To prevent bodily injury or death from the unexpected start-up of the machine, always stop the engine and remove the key from the ignition before making adjustments to the machine.

DANGER

Ensure that all bystanders have cleared the area.

SETTING UP AUTO HEADER HEIGHT CONTROL SYSTEM

1. Position the header so that the cutterbar is 254–356 mm (10–14 in.) off the ground.
2. Shut down the engine, and remove the key from the ignition.
3. Unlock the header float. For instructions, refer to the header operator's manual.

CAUTION

To prevent cuts, pinches, and other bodily harm to the person checking the down stops, ensure that nobody is manually lifting, bouncing, or moving the header in any way while the down stop washer is being touched and checked for movement.

4. Ensure that the float lock linkage is on the down stops (washer [A] cannot move) at both locations.

NOTE:

If the header is **NOT** on the down stops, the voltage may go out of range during operation and cause the AHHC system to malfunction. To fix the problem, make the header heavier by decreasing the float. For instructions, refer to [6.10 Checking and Adjusting Header Float](#), page 229.

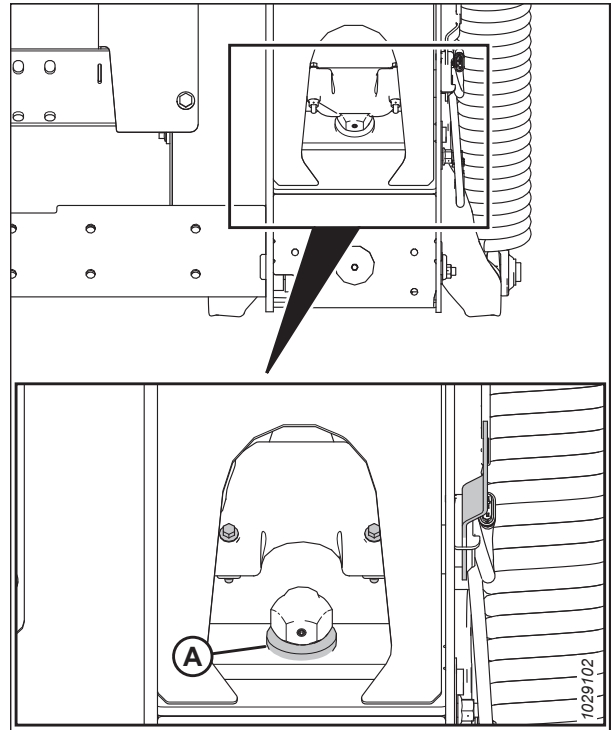

Figure 8.298: Down Stop Washer

5. If the pointer is not on zero, loosen bolt (A) and slide float indicator plate (B) until pointer (C) is on 0 (D). Tighten the nut on bolt (A).

NOTE:

Use zero dot (E) above the decal to correctly set the indicator needle.

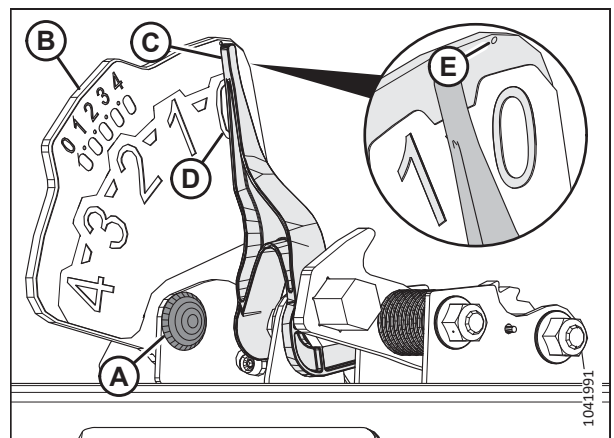

Figure 8.299: Float Indicator

SETTING UP AUTO HEADER HEIGHT CONTROL SYSTEM

6. Select CALIBRATION icon (A) on the main page of the display. The CALIBRATION page appears.

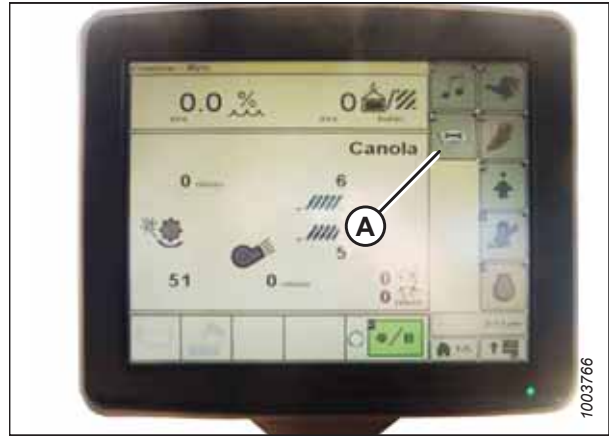

Figure 8.300: John Deere Combine Display

7. Select DIAGNOSTIC READINGS icon (A) on the CALIBRATION page. The DIAGNOSTIC READINGS page appears. This page provides access to calibrations, header options, and diagnostic information.

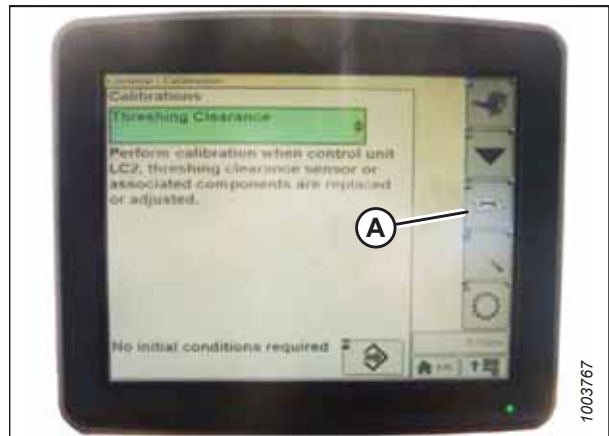

Figure 8.301: John Deere Combine Display

8. Select AHHC RESUME (A) and a list of calibration options appears.



Figure 8.302: John Deere Combine Display

SETTING UP AUTO HEADER HEIGHT CONTROL SYSTEM

9. Select the AHHC SENSING option.
10. Press icon (A). The AHHC SENSING menu appears and five pages of information appear.



Figure 8.303: John Deere Combine Display

11. Press icon (A) until it reads Page 5 near the top of the page and the following sensor readings appear:
 - LEFT HEADER HEIGHT
 - CENTER HEADER HEIGHT
 - RIGHT HEADER HEIGHT

A reading is displayed for both the left and right sensors. On the MacDon header, there may be one sensor located in the float indicator box (standard) or two sensors located at the back of the float module side frame (optional).

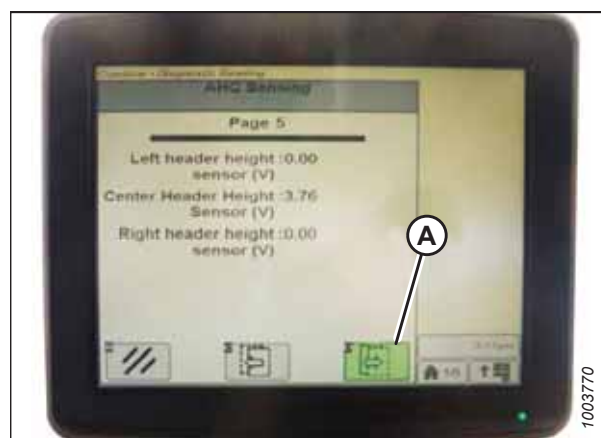

Figure 8.304: John Deere Combine Display

12. Ensure that the header float is unlocked.
13. Start the engine.
14. Fully lower the feeder house to the ground.

NOTE:

You may need to hold the HEADER DOWN switch for a few seconds to fully lower the feeder house.

15. Check the voltage reading on the display. For information on the appropriate voltage range, refer to [8.1.2 Recommended Sensor Output Voltages for Combines, page 268](#).
16. If the sensor voltage is not within the lower and upper limits, or if the range between the lower and upper limits is insufficient, refer to [8.1.3 Manually Checking Voltage Limits, page 269](#).

Adjusting Manual Header Raise/Lower Rate – John Deere S and T Series

The rate at which the header can be raised or lowered using the combine controls can be changed from the height sensitivity screen in the combine CommandCenter™.

NOTE:

Changes may have been made to the combine controls or the display since this document was published. For the most up-to-date information, refer to the combine operator's manual.

SETTING UP AUTO HEADER HEIGHT CONTROL SYSTEM

NOTE:

Indicator (A) should be at position **0** (B) with the header 254–356 mm (10–14 in.) off the ground. When the header is on the ground, the indicator should be at position **1** (C) for low ground pressure, and at position **4** (D) for high ground pressure. The crop and soil conditions determine the amount of float to use. The ideal setting is as light as possible without the header bouncing or missing crop. Operating with heavy settings prematurely wears the cutterbar wearplates.

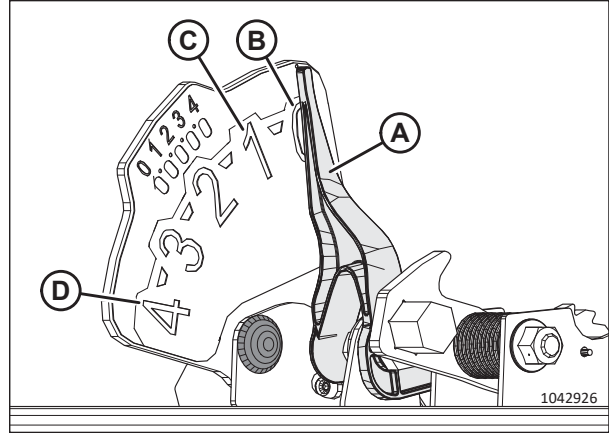

Figure 8.305: Float Indicator

1. Press button (A). The current sensitivity setting will appear on the display.



Figure 8.306: John Deere Combine CommandCenter™

2. Press – or + icons (A) to adjust the rates.

NOTE:

The numbers shown on the combine display in this illustration are for reference purposes only; they are not intended to represent the specific settings for your equipment.

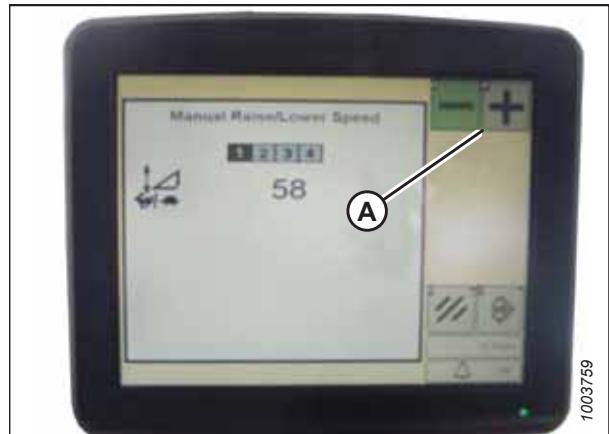

Figure 8.307: John Deere Combine Display

SETTING UP AUTO HEADER HEIGHT CONTROL SYSTEM

CAUTION

To prevent cuts, pinches, and other bodily harm to the person checking the down stops, ensure that nobody is manually lifting, bouncing, or moving the header in any way while the down stop washer is being touched and checked for movement.

7. Ensure that the float lock linkage is on the down stops (washer [A] cannot move) at both locations.

NOTE:

If the header is **NOT** on the down stops, the voltage may go out of range during operation and cause the AHHC system to malfunction. To fix the problem, make the header heavier by decreasing the float. For instructions, refer to [6.10 Checking and Adjusting Header Float, page 229](#).

8. Unlock the header float. For instructions, refer to the header operator's manual.

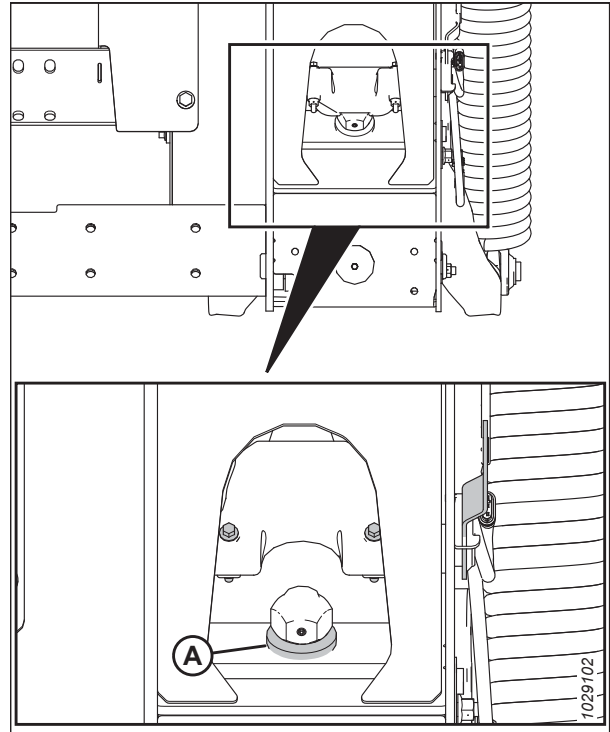

Figure 8.309: Down Stop Washer

9. Select DIAGNOSTIC icon (A) on the main page of the display. The CALIBRATION page appears.



Figure 8.310: John Deere Combine Display

SETTING UP AUTO HEADER HEIGHT CONTROL SYSTEM

10. Select THRESHING CLEARANCE (A). A list of calibration options appears.

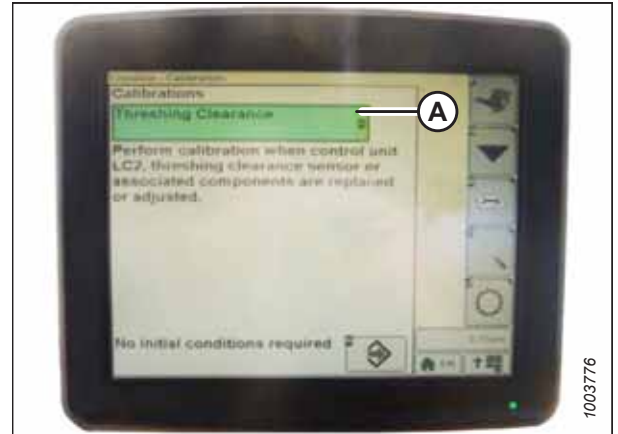

Figure 8.311: John Deere Combine Display

11. Select FEEDER HOUSE SPEED (A) from the list of calibration options.

NOTE:

Calibrate the feeder house speed before calibrating the header.

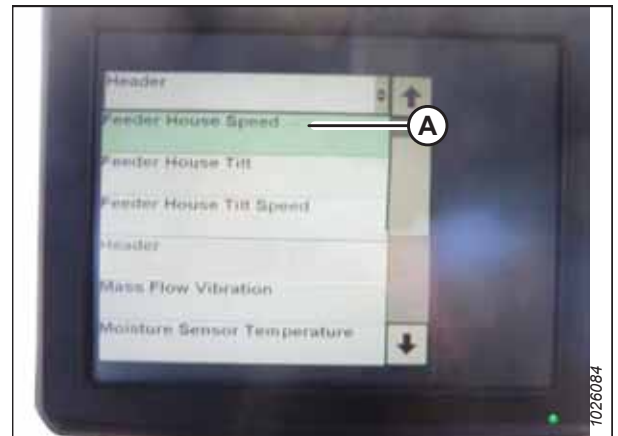

Figure 8.312: John Deere Combine Display

12. With FEEDER HOUSE SPEED selected, select icon (A). The icon turns green.

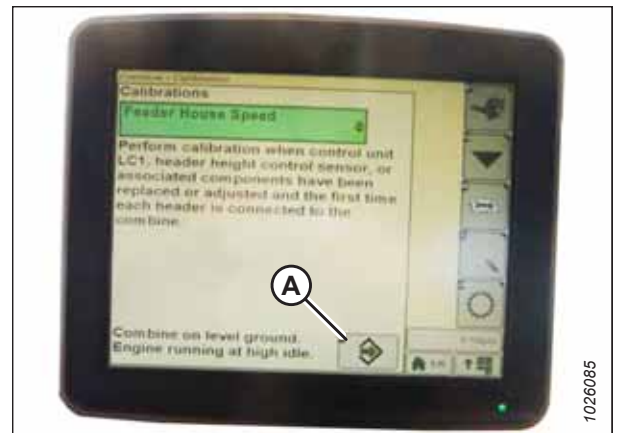

Figure 8.313: John Deere Combine Display

SETTING UP AUTO HEADER HEIGHT CONTROL SYSTEM

13. Select icon (A). Instructions appear on the screen to guide you through the calibration process.

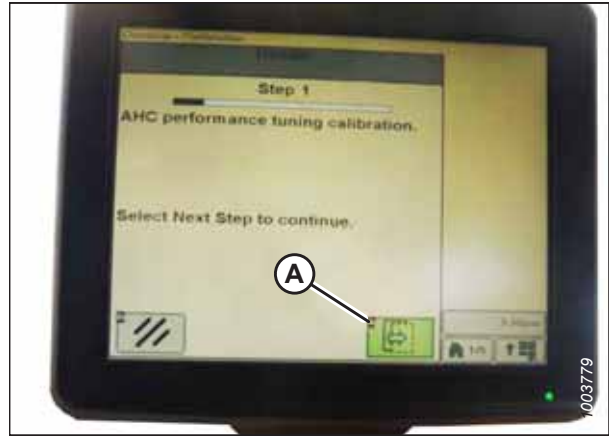

Figure 8.314: John Deere Combine Display

14. Select HEADER (A) from the list of calibration options.

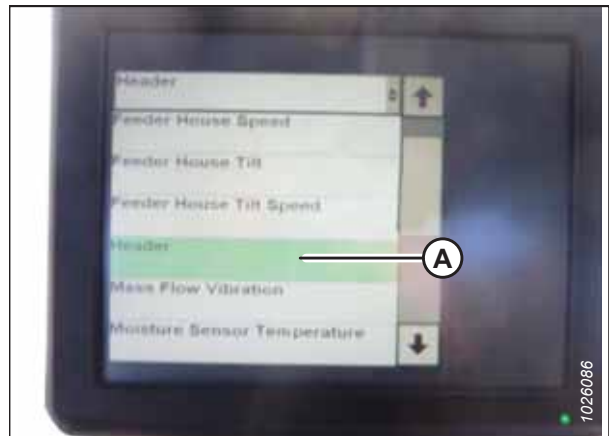

Figure 8.315: John Deere Combine Display

15. With HEADER selected, select icon (A). The icon turns green.

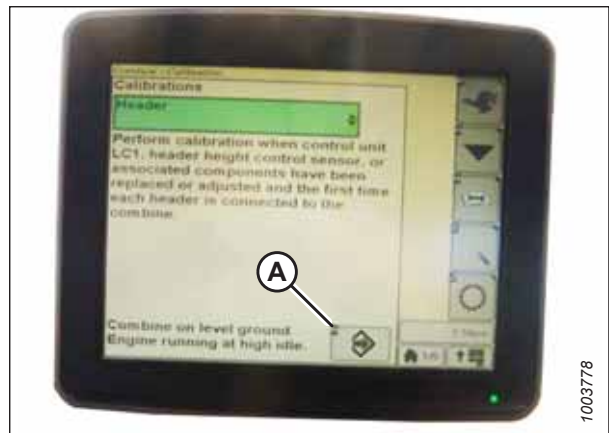

Figure 8.316: John Deere Combine Display

SETTING UP AUTO HEADER HEIGHT CONTROL SYSTEM

16. Select icon (A). Instructions appear on the screen to guide you through the calibration process.

NOTE:

If an error code appears during calibration, the sensor will require adjustment. For instructions, refer to [Checking Voltage Range from Combine Cab – John Deere S and T Series](#), page 410.

NOTE:

If the float was set heavier to complete the calibration process, adjust the float to the recommended operating float after calibration is complete.

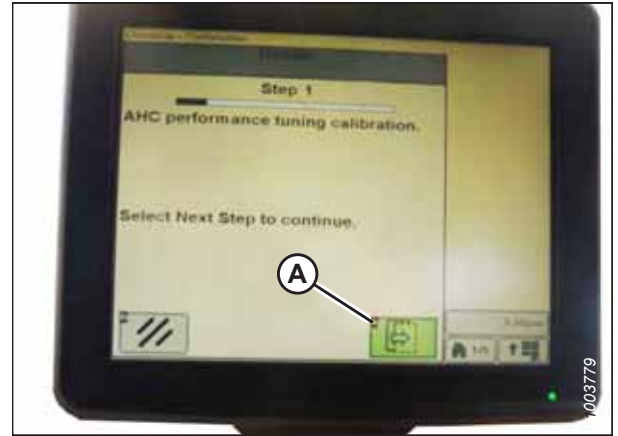

Figure 8.317: John Deere Combine Display

Setting Auto Header Height Control Sensitivity – John Deere S and T Series

The sensitivity adjustment controls the distance the cutterbar must travel up or down before the auto header height control (AHC) reacts and raises or lowers the feeder house.

When the sensitivity is set to maximum, only small changes in ground height raise or lower the feeder house. When the sensitivity is set to minimum, large changes in the ground height will raise or lower the feeder house.

NOTE:

Changes may have been made to the combine controls or the display since this document was published. For the most up-to-date information, refer to the combine operator's manual.

1. Press button (A) twice and the current sensitivity setting will appear on the display.



Figure 8.318: John Deere Combine Console

SETTING UP AUTO HEADER HEIGHT CONTROL SYSTEM

2. Press – or + icons (A) to adjust the rates.

NOTE:

The numbers shown on the combine display in this illustration are for reference purposes only; they are not intended to represent the specific settings for your equipment.



Figure 8.319: John Deere Combine Display

Setting Preset Cutting Height – John Deere S and T Series

The reel and cut height setting can be stored in the combine's computer as presets. These settings can be set and selected using the combine's control handle.

NOTE:

Changes may have been made to the combine controls or the display since this document was published. For the most up-to-date information, refer to the combine operator's manual.

1. Ensure indicator (A) is at position 0 (B) with the header 254–356 mm (10–14 in.) off the ground.

NOTE:

When the header is on the ground, the indicator should be at position 1 (C) for low ground pressure, and at position 4 (D) for high ground pressure. The crop and soil conditions determine the amount of float to use. The ideal setting is as light as possible without the header bouncing or missing crop. Operating the header with heavy settings prematurely wears the cutterbar wearplates.

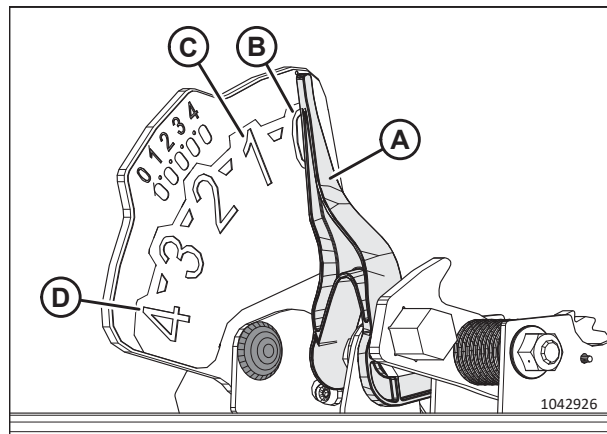

Figure 8.320: Float Indicator

SETTING UP AUTO HEADER HEIGHT CONTROL SYSTEM

2. Select COMBINE – HEADER SETUP icon (A) on the main page. The COMBINE – HEADER SETUP page appears. This page is used to set various header settings such as reel speed, header width, and height of feeder house for acre counter engagement.



Figure 8.321: Combine Display

3. Select COMBINE – HEADER SETUP AHC icon (A). The COMBINE – HEADER SETUP AHC page appears.



Figure 8.322: Combine Display

4. Select AUTO HEIGHT SENSING (A), RETURN TO CUT (B), and REEL POSITION (C) icons.

NOTE:

If REEL POSITION icon (C) cannot be selected (no check mark), the reel height sensor requires calibration. For instructions, refer to *Calibrating Reel Height Sensor and Reel Fore-Aft Sensor – John Deere S and T Series, page 428*.

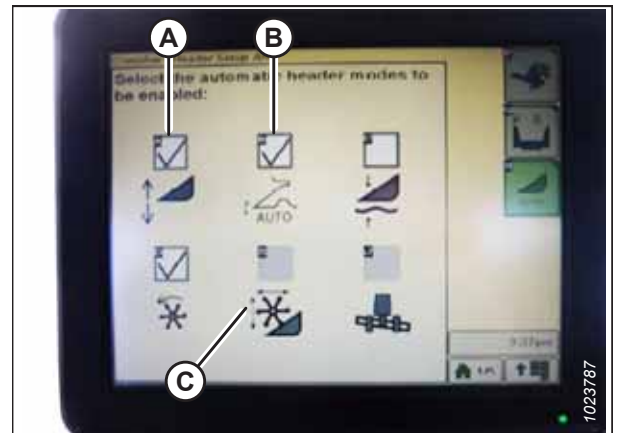

Figure 8.323: Combine Display

SETTING UP AUTO HEADER HEIGHT CONTROL SYSTEM

- Engage the header.
- Move the header to the desired position and use knob (A) to fine tune the position.
- Move the reel to the desired position.



Figure 8.324: Combine Control Console

- Press and hold preset switch 2 (B) until the reel height icon flashes on display.
- Repeat Step 6, page 422 to Step 8, page 422 for preset switch 3 (C).
- Select an appropriate ground pressure setting. Use preset button 2 (B) on the control handle for a low ground pressure setting in muddy or soft soil conditions, and preset 3 (C) for a high ground pressure setting in firm soil conditions and a higher ground speed.

NOTE:

Preset button 1 (A) is reserved for header lift on the headland and is not used for cutting on the ground.

NOTE:

When the AHHC is engaged, AHHC icon (A) appears on the display and the number indicating which button was pressed (B) is shown on the page.



Figure 8.325: Control Handle Buttons

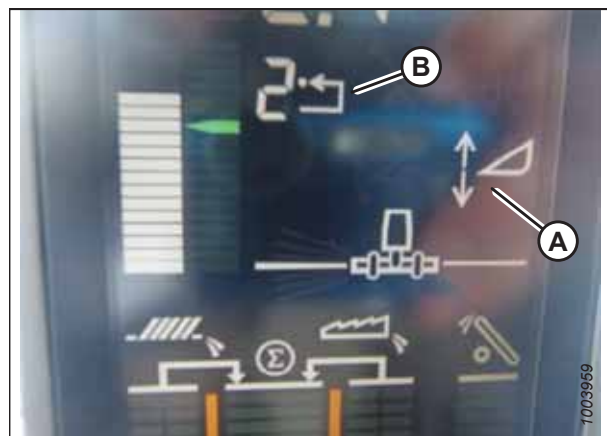

Figure 8.326: Combine Display

SETTING UP AUTO HEADER HEIGHT CONTROL SYSTEM

Calibrating Feeder House Fore-Aft Tilt Range – John Deere S and T Series

Follow this procedure to properly calibrate the combine feeder house fore-aft tilt range.

NOTE:

Changes may have been made to the combine controls or the display since this document was published. For the most up-to-date information, refer to the combine operator's manual.

NOTE:

This procedure applies only to model year 2015 and later John Deere S and T Series Combines.

The feeder house fore/aft tilt is controlled by buttons (C) and (D) at the back of the control handle.



Figure 8.327: John Deere Control Handle

NOTE:

The feeder house fore/aft tilt controls can be changed to work with buttons E and F by selecting control handle icon (A) and then selecting FEEDER HOUSE FORE/AFT TILT from drop-down menu (B).

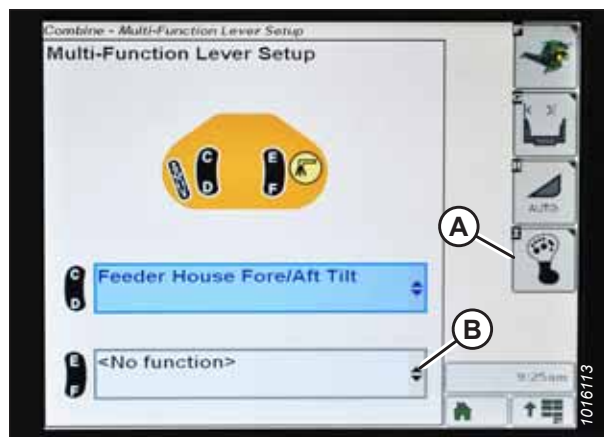

Figure 8.328: John Deere Combine Display

To calibrate the feeder house fore-aft tilt range, follow these steps:

1. Ensure that the center-link is set to **D**.

NOTE:

When setup and calibration are complete, adjust the center-link back to the desired header angle. For instructions, refer to the header operator's manual.

2. Rest the header on the down stops.
3. Unlock the header float. For instructions, refer to the header operator's manual.

SETTING UP AUTO HEADER HEIGHT CONTROL SYSTEM

4. Select DIAGNOSTIC icon (A) on the main page of the display. The CALIBRATION page appears.

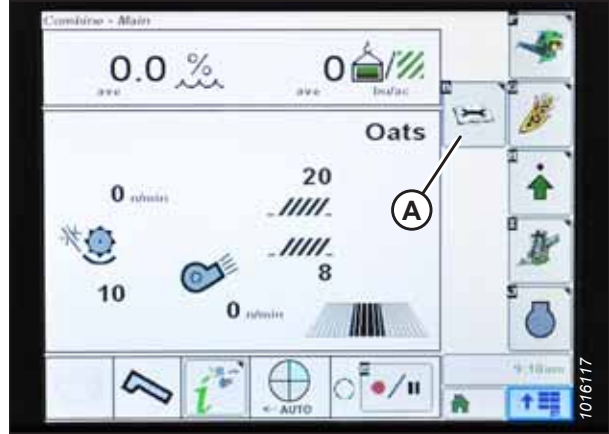

Figure 8.329: John Deere Combine Display

5. Select CALIBRATIONS drop-down menu (A) to view the list of calibration options.



Figure 8.330: John Deere Combine Display

6. Select arrow (A) to cycle up through the calibration options and select FEEDER HOUSE FORE/AFT TILT RANGE.

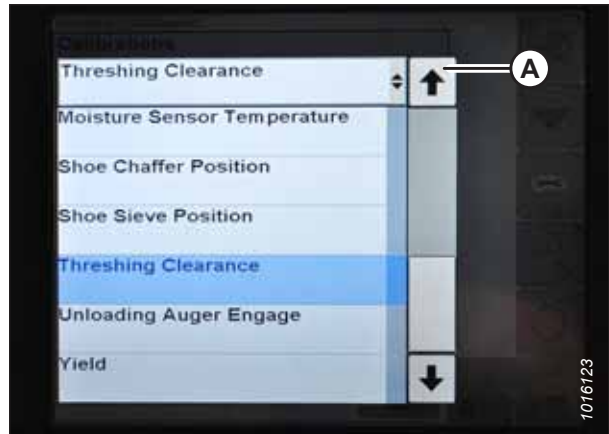

Figure 8.331: John Deere Combine Display

SETTING UP AUTO HEADER HEIGHT CONTROL SYSTEM

7. Select ENTER icon (A).

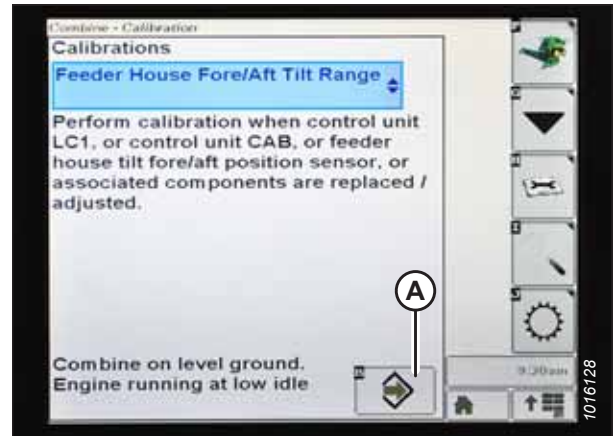

Figure 8.332: John Deere Combine Display

8. Follow the instructions on the page. As you proceed through the calibration process, the display automatically updates to show the next step.

NOTE:

If an error code appears during calibration, the sensor will require adjustment. For instructions, refer to [Checking Voltage Range from Combine Cab – John Deere S and T Series, page 410](#).

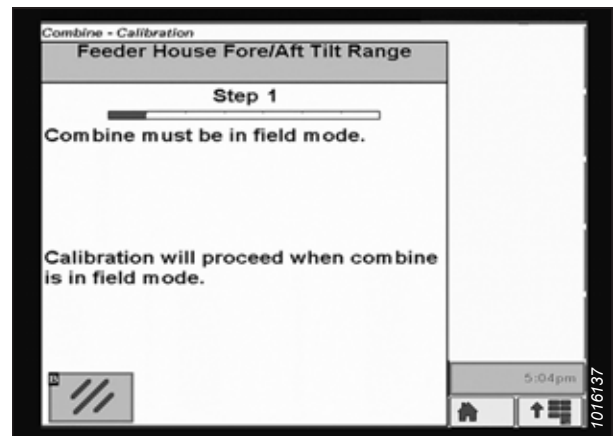

Figure 8.333: John Deere Combine Display

Checking Reel Height Sensor Voltages – John Deere S and T Series

Check the reel height sensor voltages to ensure that they are within the required range.

NOTE:

Changes may have been made to the combine controls or the display since this document was published. For the most up-to-date information, refer to the combine operator's manual.

SETTING UP AUTO HEADER HEIGHT CONTROL SYSTEM

1. Select CALIBRATION icon (A) on the main page of the display. The CALIBRATION page appears.



Figure 8.334: John Deere Combine Display

2. Select DIAGNOSTIC READINGS icon (A) on the CALIBRATION page. The DIAGNOSTIC READINGS page appears. This page provides access to calibrations, header options, and diagnostic information.

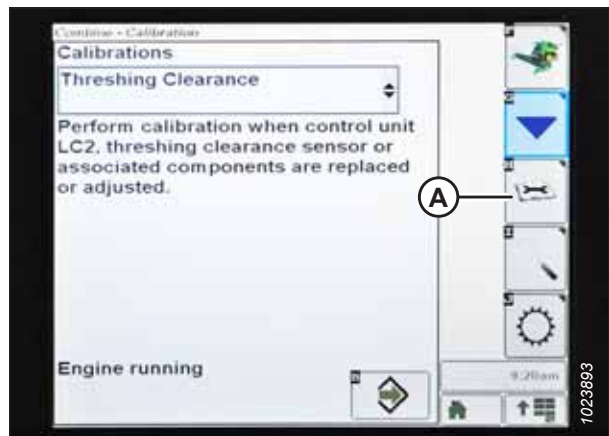

Figure 8.335: John Deere Combine Display

3. Select drop-down menu (A) to view the list of calibration options.

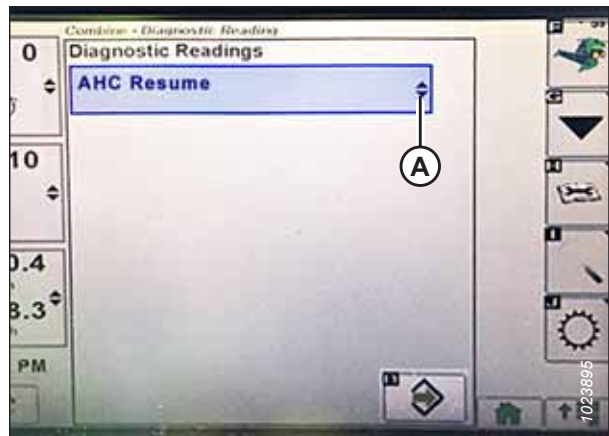

Figure 8.336: John Deere Combine Display

SETTING UP AUTO HEADER HEIGHT CONTROL SYSTEM

4. Scroll down and select REEL RESUME (A).



Figure 8.337: John Deere Combine Display

5. Select ENTER icon (A). The REEL RESUME page appears.

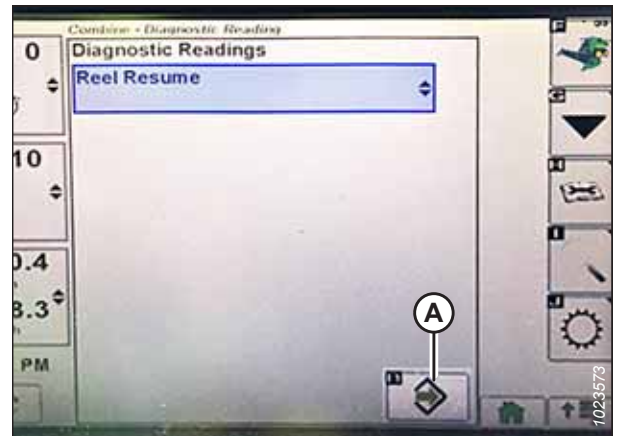

Figure 8.338: John Deere Combine Display

6. Select NEXT PAGE icon (A) to cycle to page 3.
7. Lower the reel to view lower voltage limit (B). The voltage should be within 0.5–0.9 V.

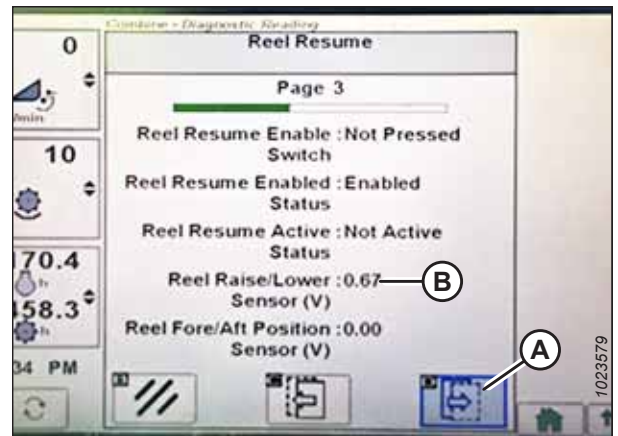

Figure 8.339: John Deere Combine Display

SETTING UP AUTO HEADER HEIGHT CONTROL SYSTEM

8. Raise the reel to view upper voltage limit (A). The voltage should be within 4.1–4.3 V.
9. If either voltage is not within the correct range, refer to [7.1 Checking and Adjusting Reel Height Sensor](#), page 259.

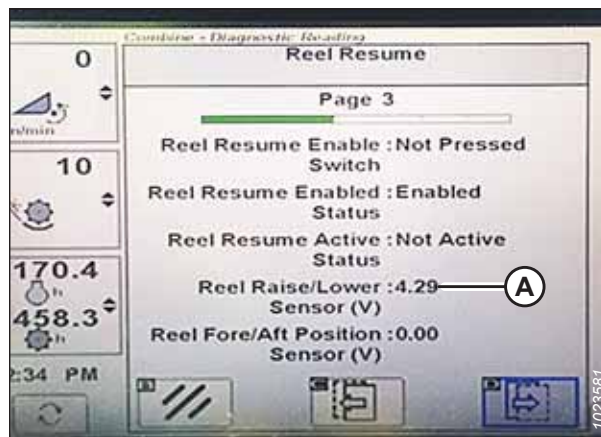

Figure 8.340: John Deere Combine Display

Calibrating Reel Height Sensor and Reel Fore-Aft Sensor – John Deere S and T Series

The auto header height control (AHHC) sensor output must be calibrated for each combine, or the reel position feature will not work properly. The following procedure applies only to model year 2015 and later John Deere S and T Series Combines.

NOTE:

Changes may have been made to the combine controls or the display since this document was published. For the most up-to-date information, refer to the combine operator's manual.

DANGER

Ensure that all bystanders have cleared the area.

1. Start the engine.
2. Position the header 254–356 mm (10–14 in.) off the ground.

IMPORTANT:

Do **NOT** turn off the engine. The combine has to be at a full idle to properly calibrate the sensors.

3. Select DIAGNOSTIC icon (A) on the main page of the display. The CALIBRATION page is shown.



Figure 8.341: John Deere Combine Display

SETTING UP AUTO HEADER HEIGHT CONTROL SYSTEM

4. Select CALIBRATIONS drop-down menu (A) to view the list of calibration options.
5. Scroll through the list of options and select REEL POSITION.
6. Select ENTER icon (B).

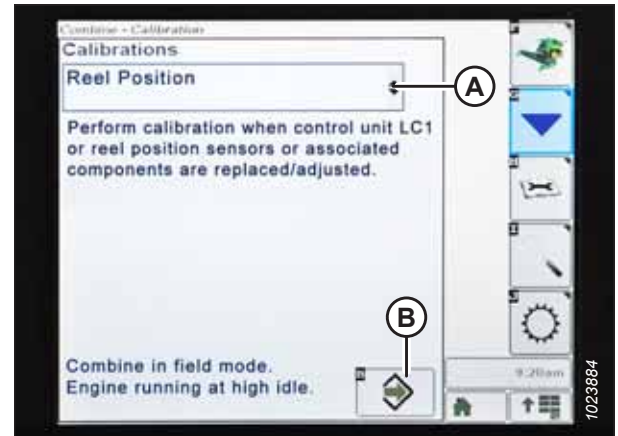

Figure 8.342: John Deere Combine Display

7. Follow the instructions that appear on the page. As you proceed through the calibration process, the display will automatically update to show the next step. This calibration requires you to use reel raise (A) and reel lower (B) switches on the control handle.



Figure 8.343: John Deere Control Handle

8. Press and hold the REEL LOWER switch until the reel is fully lowered. Continue holding the REEL LOWER switch until prompted by the display.



Figure 8.344: John Deere Combine Display

SETTING UP AUTO HEADER HEIGHT CONTROL SYSTEM

9. Press and hold the REEL RAISE switch until the reel is fully raised. Continue holding the REEL RAISE switch until prompted by the display.



Figure 8.345: John Deere Combine Display

10. When all steps have been completed, CALIBRATION COMPLETE message is displayed on the page. Exit the CALIBRATION menu by pressing ENTER icon (A).

NOTE:

If an error code appears during calibration, the sensor will require adjustment. For instructions, refer to [Checking Reel Height Sensor Voltages – John Deere S and T Series, page 425](#).

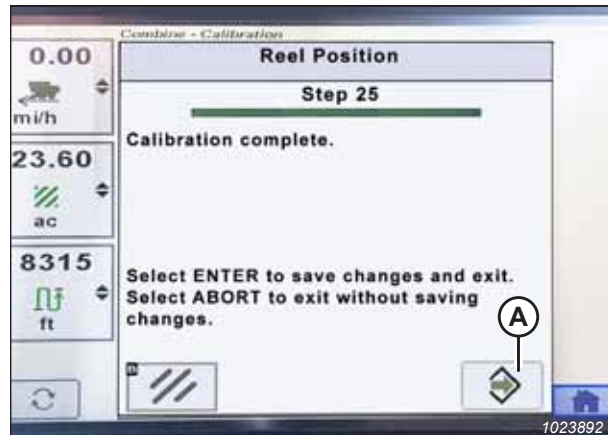

Figure 8.346: John Deere Combine Display

8.1.17 John Deere S7 Series Combines

To make your header's auto header height control (AHHC) system compatible with John Deere S7 Series combines, you must set your combine's header configuration options for the particular model of header, configure the reel speed settings, set up the AHHC controls, and calibrate the AHHC system to ensure that it is working correctly.

Setting up Header – John Deere S7 Series

Set these initial configuration options on your combine when setting up the auto header height control (AHHC) system.

NOTE:

Changes may have been made to the combine controls or the display since this document was published. For the most up-to-date information, refer to the combine operator's manual.

SETTING UP AUTO HEADER HEIGHT CONTROL SYSTEM

1. Press HEADER button (A) on the panel below the display. The HEADER page appears.



Figure 8.347: John Deere S7 Display

2. Select HEADER TYPE field (A). The HEADER DETAILS dialog box opens.



Figure 8.348: John Deere S7 Display – Header Page

3. Verify the correct header width is displayed under WIDTH.
4. To change the header width, select field (A). The WIDTH dialog box opens.



Figure 8.349: John Deere S7 Display – Header Details Window

SETTING UP AUTO HEADER HEIGHT CONTROL SYSTEM

5. Use the on-screen keypad to enter the correct header width, and then select OK.



Figure 8.350: John Deere S7 Display – Setting Header Width

6. Select close button (A) in the top right corner to return to the HEADER page.



Figure 8.351: John Deere S7 Display – Header Details Dialog Box

7. Raise/lower speed (A), tilt speed (B), height sensitivity (C), and tilt sensitivity (D) can be adjusted from this page. Select the option you would like to adjust. The following example shows the raise/lower speed adjustment.



Figure 8.352: John Deere S7 Display – Header Page

SETTING UP AUTO HEADER HEIGHT CONTROL SYSTEM

- Use + and – buttons (A) to adjust the setting.
- Select the X button in the top right corner of the window to return to the HEADER page.

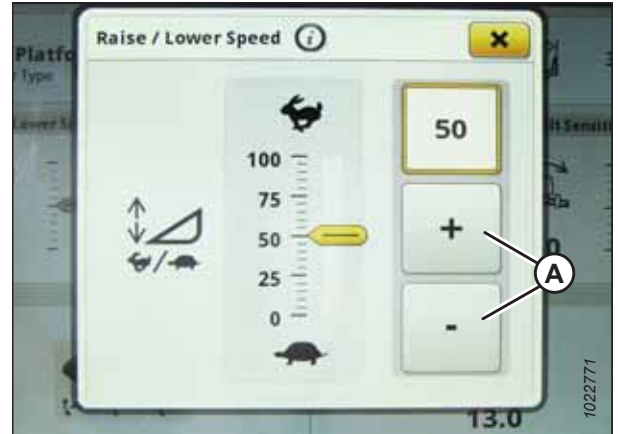

Figure 8.353: John Deere S7 Display – Raise/Lower Speed Adjustment

- Select AUTO CONTROL icons (A). The AUTO HEADER CONTROLS page opens.



Figure 8.354: John Deere S7 Display – Header Page

- If the header has not been calibrated yet, an error icon will appear on HEIGHT SENSING button (A). Select button (A) to view the error message.

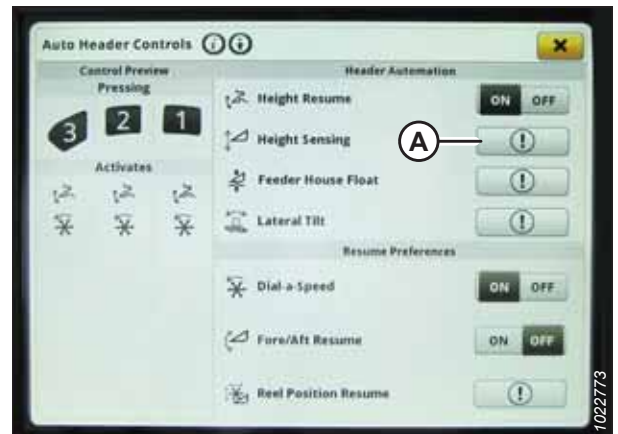

Figure 8.355: John Deere S7 Display – Auto Header Controls

SETTING UP AUTO HEADER HEIGHT CONTROL SYSTEM

12. Read the error message, then select OK.
13. Proceed to *Checking Voltage Range from Combine Cab – John Deere S7 Series, page 434.*

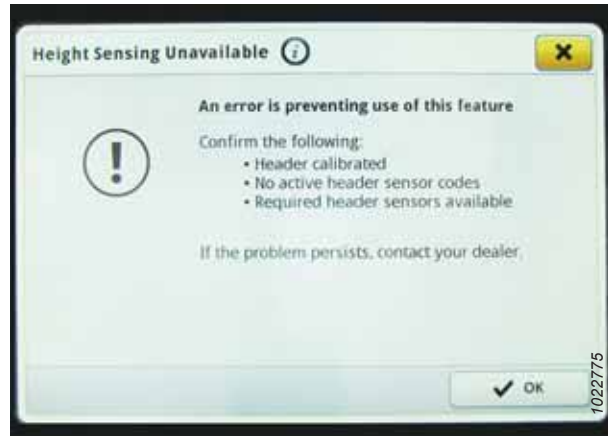

Figure 8.356: John Deere S7 Display – Height Sensing Error Message

Checking Voltage Range from Combine Cab – John Deere S7 Series

The auto header height control (AHHC) sensor output must be within a specific range, or the feature will not work properly.

NOTE:

Changes may have been made to the combine controls or the display since this document was published. For the most up-to-date information, refer to the combine operator's manual.

DANGER

To prevent bodily injury or death from the unexpected start-up of the machine, always stop the engine and remove the key from the ignition before making adjustments to the machine.

DANGER

Ensure that all bystanders have cleared the area.

1. Position the header so that the cutterbar is 254–356 mm (10–14 in.) off the ground.
2. Shut down the engine, and remove the key from the ignition.
3. Unlock the header float. For instructions, refer to the header operator's manual.

SETTING UP AUTO HEADER HEIGHT CONTROL SYSTEM

CAUTION

To prevent cuts, pinches, and other bodily harm to the person checking the down stops, ensure that nobody is manually lifting, bouncing, or moving the header in any way while the down stop washer is being touched and checked for movement.

4. Ensure that the float lock linkage is on the down stops (washer [A] cannot move) at both locations.

NOTE:

If the header is **NOT** on the down stops, the voltage may go out of range during operation and cause the AHHC system to malfunction. To fix the problem, make the header heavier by decreasing the float. For instructions, refer to [6.10 Checking and Adjusting Header Float, page 229](#).

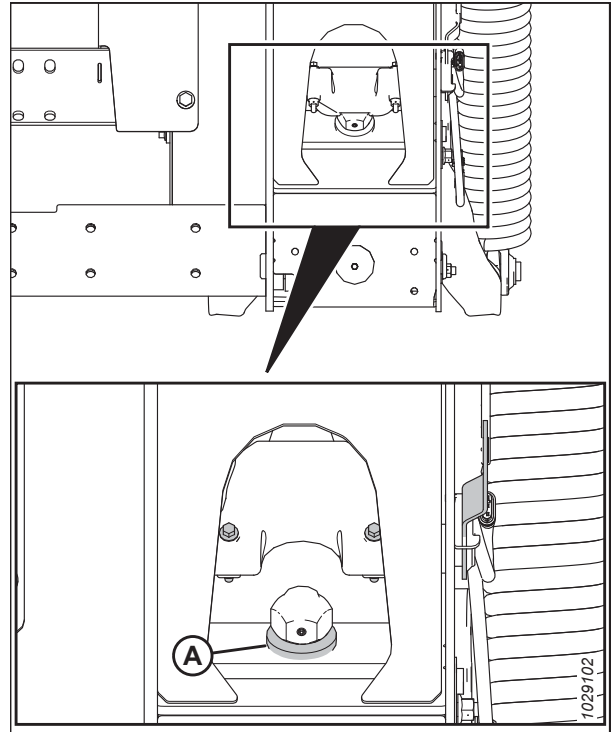

Figure 8.357: Down Stop Washer

5. If the pointer is not on zero, loosen bolt (A) and slide float indicator plate (B) until pointer (C) is on 0 (D). Tighten the nut on bolt (A).

NOTE:

Use zero dot (E) above the decal to correctly set the indicator needle.

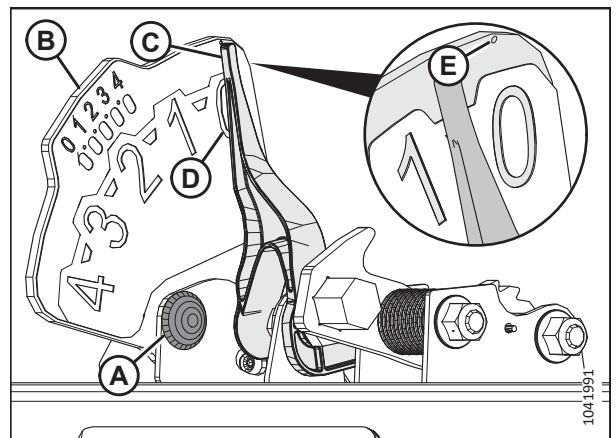

Figure 8.358: Float Indicator

SETTING UP AUTO HEADER HEIGHT CONTROL SYSTEM

- On the HARVESTING page, select MENU icon (A) in the bottom right corner of the page.



Figure 8.359: John Deere S7 Display – Harvesting Page

- On the MENU page, select SYSTEM tab (A). The MENU opens.
- Select DIAGNOSTICS CENTER icon (B). The DIAGNOSTICS CENTER page opens.

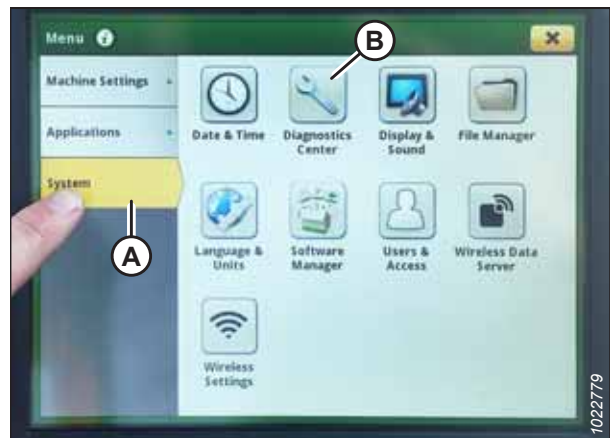

Figure 8.360: John Deere S7 Display – Menu

- Select AHC - SENSING (A). The AHC - SENSING \DIAGNOSTICS page appears.

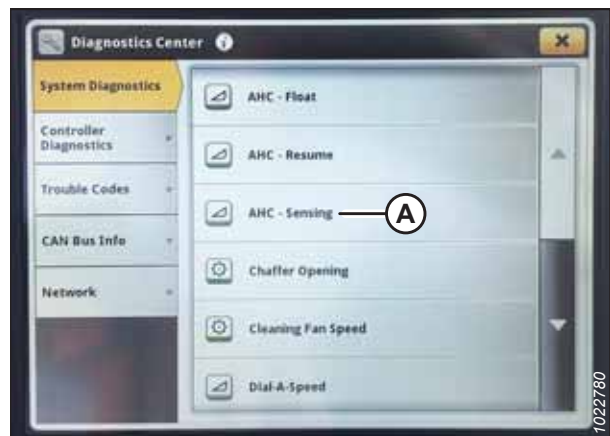

Figure 8.361: John Deere S7 Display – Diagnostics Center

SETTING UP AUTO HEADER HEIGHT CONTROL SYSTEM

10. Select SENSOR tab (A) to view the sensor voltages. Center header height sensor voltage (B) must be between 0.7 and 4.3 V, with at least 3 V of variation between 0 and 4 on the float indicator box.
11. If the sensor voltage is not within the lower and upper limits, or if the range between the lower and upper limits is insufficient, refer to [8.1.3 Manually Checking Voltage Limits](#), page 269.

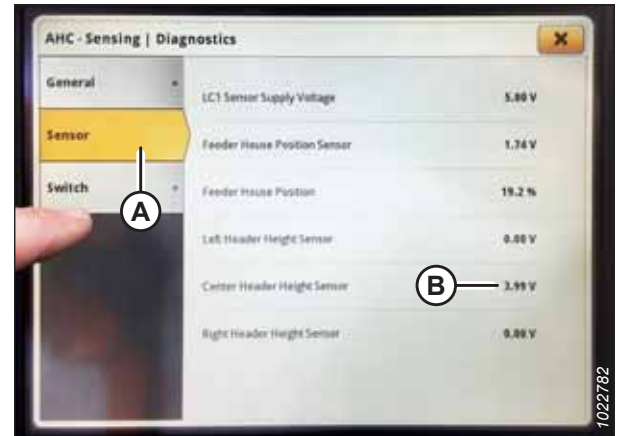

Figure 8.362: John Deere S7 Display – Checking Sensor Voltage

Calibrating Feeder House – John Deere S7 Series

The feeder house must be calibrated before calibrating the header.

DANGER

Ensure that all bystanders have cleared the area.

NOTE:

Changes may have been made to the combine controls or the display since this document was published. For the most up-to-date information, refer to the combine operator's manual.

1. Start the engine.
2. Ensure that the center-link is set to **D**.

NOTE:

When calibration is complete, adjust the center-link back to the desired header angle. For instructions, refer to the header operator's manual.

3. Rest the header on the down stops.
4. Unlock the header float. For instructions, refer to the header operator's manual.
5. Shut down the engine, and remove the key from the ignition.

SETTING UP AUTO HEADER HEIGHT CONTROL SYSTEM

- On the HARVESTING page, select MENU icon (A) in the bottom right corner of page. The MENU opens.



Figure 8.363: John Deere S7 Display – Harvesting Page

- Select MACHINE SETTINGS tab (A).
- Select CALIBRATIONS & PROCEDURES icon (B). The CALIBRATIONS & PROCEDURES page appears.



Figure 8.364: John Deere S7 Display – Machine Settings

- Select HEADER tab (A).
- Select FEEDER HOUSE RAISE SPEED CALIBRATION (B). The FH RAISE SPEED CALIBRATION page appears.

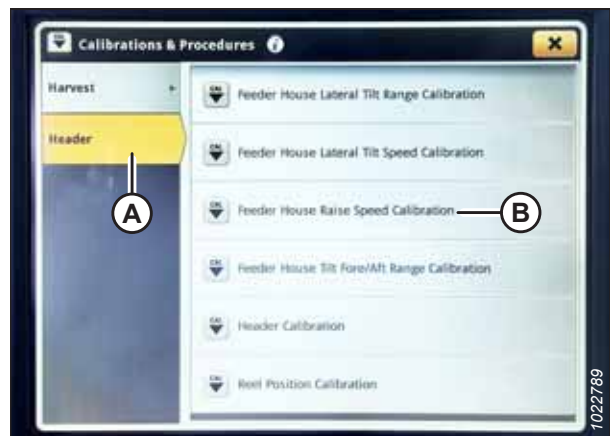

Figure 8.365: John Deere S7 Display – Calibrations and Procedures

SETTING UP AUTO HEADER HEIGHT CONTROL SYSTEM

11. Select CALIBRATE (A) at the bottom of the page. A calibration overview appears.

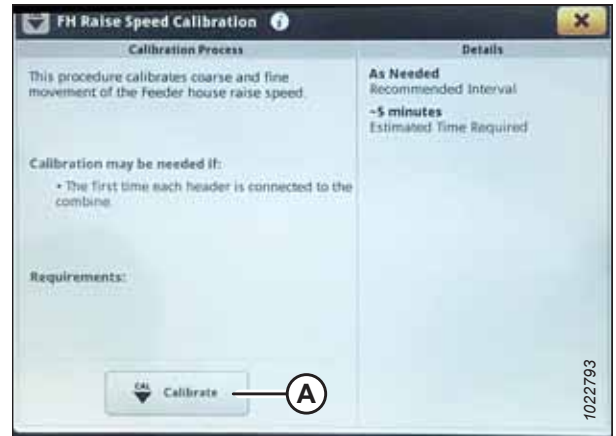

Figure 8.366: John Deere S7 Display – Feeder House Calibration

12. Read the calibration overview, then press START.



Figure 8.367: John Deere S7 Display – Feeder House Calibration

13. Follow the instructions on the page. As you proceed through the calibration process, the display automatically updates to show the next step.



Figure 8.368: John Deere S7 Display – Feeder House Calibration

SETTING UP AUTO HEADER HEIGHT CONTROL SYSTEM

14. When calibration is complete, select SAVE.



Figure 8.369: John Deere S7 Display – Feeder House Calibration

Calibrating Header – John Deere S7 Series

Before the auto header height control (AHHC) system can be used, the header must be calibrated.

The feeder house must be calibrated before calibrating the header. If the feeder house has not yet been calibrated, refer to [Calibrating Feeder House – John Deere S7 Series, page 437](#).

DANGER

To prevent bodily injury or death from the unexpected start-up of the machine, always stop the engine and remove the key from the ignition before making adjustments to the machine.

DANGER

Ensure that all bystanders have cleared the area.

NOTE:

Changes may have been made to the combine controls or the display since this document was published. For the most up-to-date information, refer to the combine operator's manual.

NOTE:

If the header float is set too light, it can prevent the calibration of the AHHC. In order to prevent the header from separating from the float module, it may be necessary to change the float to a heavier setting during calibration.

SETTING UP AUTO HEADER HEIGHT CONTROL SYSTEM

1. Park the combine on a level surface.
2. Ensure that the header is level with the ground. If adjustment is required, refer to [10.5 Leveling Header, page 526](#).

NOTE:

Spirit level (A) is located on top of the float module frame. The header is level if the bubble is in the center of the spirit level.

3. Ensure that the center-link is set to **D**.

NOTE:

When calibration is complete, adjust the center-link back to the desired header angle. For instructions, refer to the header operator's manual.

4. Adjust the reel fore-aft position so that the indicator is at position **6**.
5. Position the header so that the cutterbar is 254–356 mm (10–14 in.) off the ground.
6. Shut down the engine, and remove the key from the ignition.



CAUTION

To prevent cuts, pinches, and other bodily harm to the person checking the down stops, ensure that nobody is manually lifting, bouncing, or moving the header in any way while the down stop washer is being touched and checked for movement.

7. Ensure that the float lock linkage is on the down stops (washer [A] cannot move) at both locations.

NOTE:

If the header is **NOT** on the down stops, the voltage may go out of range during operation and cause the AHHC system to malfunction. To fix the problem, make the header heavier by decreasing the float. For instructions, refer to [6.10 Checking and Adjusting Header Float, page 229](#).

8. Unlock the header float. For instructions, refer to the header operator's manual.

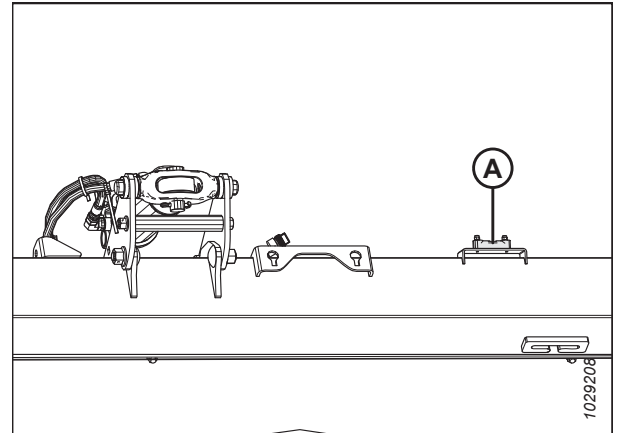

Figure 8.370: Spirit Level

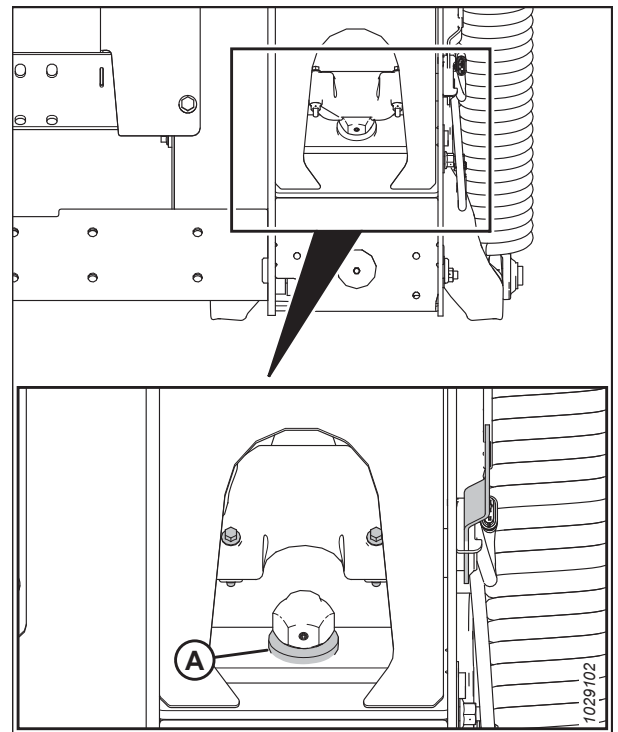

Figure 8.371: Down Stop Washer

SETTING UP AUTO HEADER HEIGHT CONTROL SYSTEM

- On the HARVESTING page, select MENU icon (A) in the bottom right corner of screen. The MENU opens.



Figure 8.372: John Deere S7 Display – Harvesting Page

- Select MACHINE SETTINGS tab (A).
- Select CALIBRATIONS & PROCEDURES icon (B). The CALIBRATIONS & PROCEDURES page appears.



Figure 8.373: John Deere S7 Display – Machine Settings

- Select HEADER tab (A).
- Select HEADER CALIBRATION (B). The HEADER CALIBRATION page appears.

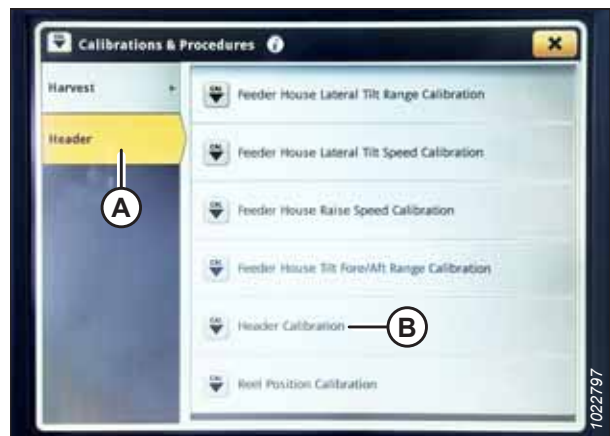

Figure 8.374: John Deere S7 Display – Calibrations and Procedures

SETTING UP AUTO HEADER HEIGHT CONTROL SYSTEM

14. Select CALIBRATE (A) at the bottom of the page. The calibration overview window opens.

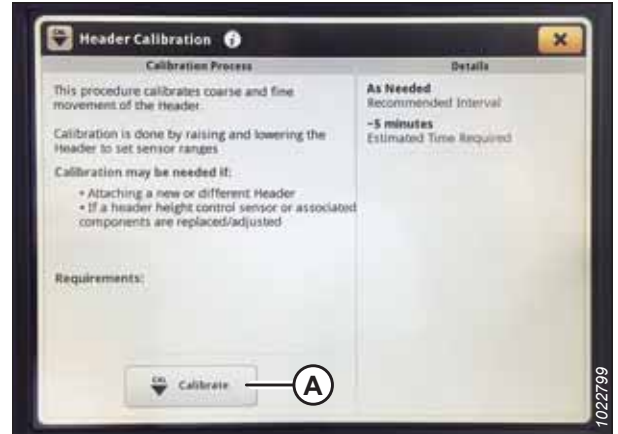

Figure 8.375: John Deere S7 Display – Header Calibration

15. Press button (A) on the console to set the engine to full throttle.



Figure 8.376: John Deere S7 Console

16. Select START on the CALIBRATION OVERVIEW page.
17. Follow the instructions that appear on the combine display. As you proceed through the calibration process, the display automatically updates to show the next step.



Figure 8.377: John Deere S7 Display – Header Calibration

SETTING UP AUTO HEADER HEIGHT CONTROL SYSTEM

18. When the calibration is complete, select SAVE.



Figure 8.378: John Deere S7 Display – Header Calibration

8.1.18 John Deere X9 Series Combines

To make your header's auto header height control (AHHC) system compatible with the combine, you must set your combine's header configuration options for the particular model of header, configure the touch screen settings, set up the AHHC controls, and calibrate the AHHC system to ensure that it is working correctly.

Setting up Header in CommandCenter™ Display – John Deere X9 Series

The main header auto header height control (AHHC) settings can be configured in the CommandCenter™ Display in the combine cab.

NOTE:

Changes may have been made to the combine controls or the display since this document was published. For the most up-to-date information, refer to the combine operator's manual.

⚠ DANGER

Ensure that all bystanders have cleared the area.

1. Start the engine.
2. Press HEADER button (A) on the panel below the display. The HEADER page opens.



Figure 8.379: CommandCenter™ Display

SETTING UP AUTO HEADER HEIGHT CONTROL SYSTEM

- Ensure that header type (A) and size (B) are correct.

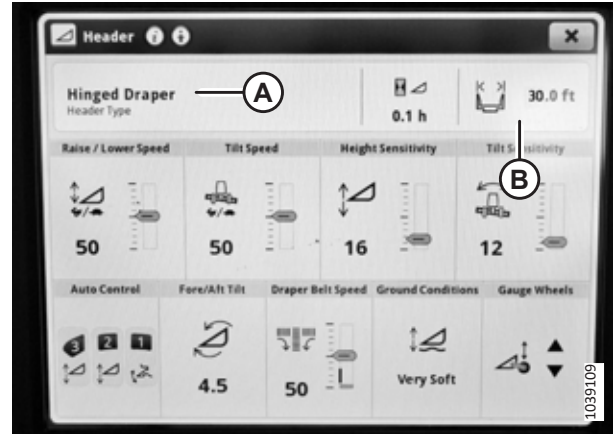

Figure 8.380: CommandCenter™ Display – Header Page

- Select AUTO CONTROL (A). The AUTO HEADER CONTROLS page opens.

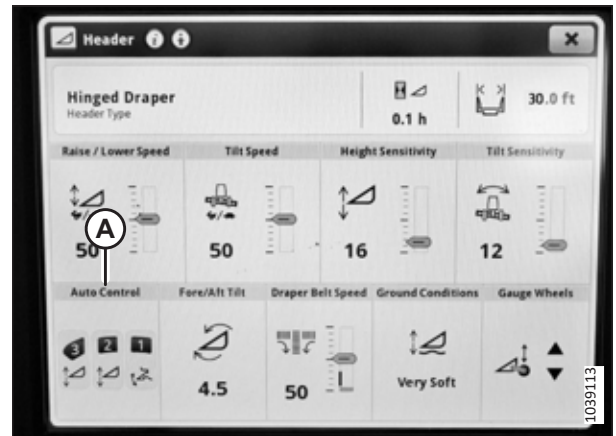

Figure 8.381: CommandCenter™ Display – Auto Header Controls Page

- On the AUTO HEADER CONTROLS page, ensure that the following HEADER AUTOMATION OPTIONS are set to ON:
 - HEIGHT RESUME
 - HEIGHT SENSING
 - LATERAL TILT
- Ensure the following RESUME PREFERENCES are set to ON:
 - AUTO REEL SPEED
 - FORE/AFT RESUME
 - REEL POSITION RESUME
- Set any other settings in the AUTO HEADER CONTROLS PAGE not referred to in the previous two steps to OFF. Press the X in the corner of the window to exit the page.

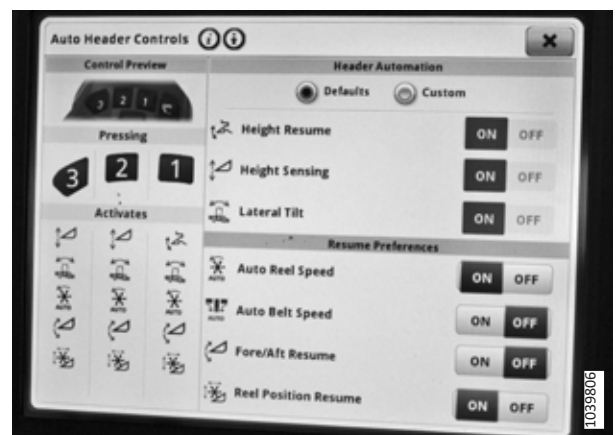

Figure 8.382: CommandCenter™ Display – Auto Header Controls Page

SETTING UP AUTO HEADER HEIGHT CONTROL SYSTEM

- On the HEADER page, select HEIGHT SENSITIVITY (A). Change the setting to 10.
- Select TILT SENSITIVITY (B). Change the setting to 10.
- Press X (C) to exit the HEADER page.

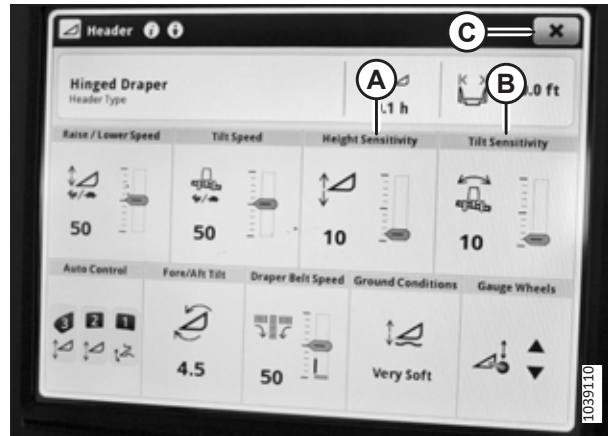

Figure 8.383: CommandCenter™ Display – Header Page

Calibrating Auto Header Height Control – John Deere X9 Series

The auto header height control (AHHC) sensor output must be calibrated for each combine, or the AHHC feature will not work properly.

DANGER

To prevent bodily injury or death from the unexpected start-up of the machine, always stop the engine and remove the key from the ignition before making adjustments to the machine.

DANGER

Ensure that all bystanders have cleared the area.

NOTE:

Changes may have been made to the combine controls or the display since this document was published. For the most up-to-date information, refer to the combine operator's manual.

NOTE:

If the header float is set too light, it can prevent the calibration of the AHHC. In order to prevent the header from separating from the float module, it may be necessary to change the float to a heavier setting during calibration.

SETTING UP AUTO HEADER HEIGHT CONTROL SYSTEM

1. Park the combine on a level surface.
2. Ensure that the header is level with the ground. If adjustment is required, refer to [10.5 Leveling Header, page 526](#).

NOTE:

Spirit level (A) is located on top of the float module frame. The header is level if the bubble is in the center of the spirit level.

3. Ensure that the center-link is set to **D**.

NOTE:

When calibration is complete, adjust the center-link back to the desired header angle. For instructions, refer to the header operator's manual.

4. Adjust the reel fore-aft position so that the indicator is at position **6**.
5. Position the header so that the cutterbar is 254–356 mm (10–14 in.) off the ground.
6. Shut down the engine, and remove the key from the ignition.



CAUTION

To prevent cuts, pinches, and other bodily harm to the person checking the down stops, ensure that nobody is manually lifting, bouncing, or moving the header in any way while the down stop washer is being touched and checked for movement.

7. Ensure that the float lock linkage is on the down stops (washer [A] cannot move) at both locations.

NOTE:

If the header is **NOT** on the down stops, the voltage may go out of range during operation and cause the AHHC system to malfunction. To fix the problem, make the header heavier by decreasing the float. For instructions, refer to [6.10 Checking and Adjusting Header Float, page 229](#).

8. Unlock the header float. For instructions, refer to the header operator's manual.

9. Move the reel to fore-aft position **6**.

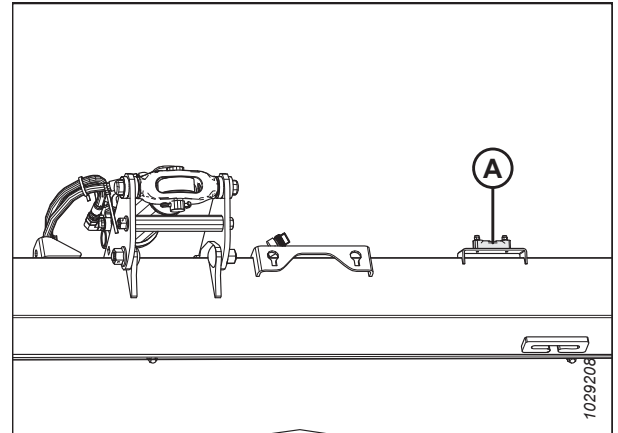

Figure 8.384: Spirit Level

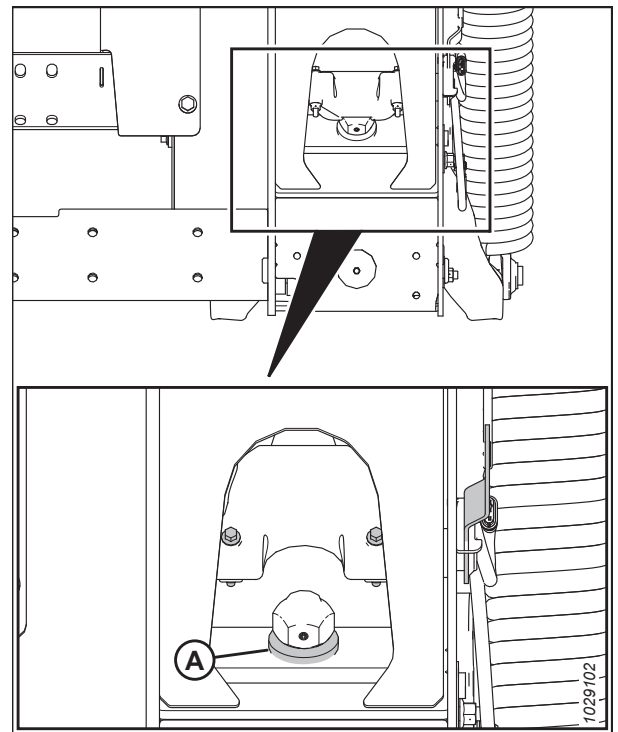

Figure 8.385: Down Stop Washer

SETTING UP AUTO HEADER HEIGHT CONTROL SYSTEM

10. On the CommandCenter™ display, select MENU icon (A) in the bottom right corner of the HARVESTING page. The MENU appears.



Figure 8.386: John Deere X9 Display – Harvesting Page

11. Select MACHINE SETTINGS tab (A).
12. Select CALIBRATIONS & PROCEDURES icon (B). The CALIBRATIONS & PROCEDURES page appears.



Figure 8.387: John Deere X9 Display – Machine Settings

13. Select HEADER tab (A).
14. Select GAUGE WHEEL RANGE CALIBRATION (B). The GAUGE WHEEL RANGE CALIBRATION page appears.
15. Follow the instructions on the page. As you proceed through the calibration process, the display will automatically update to show the next step.
16. Select SAVE to confirm the calibration.

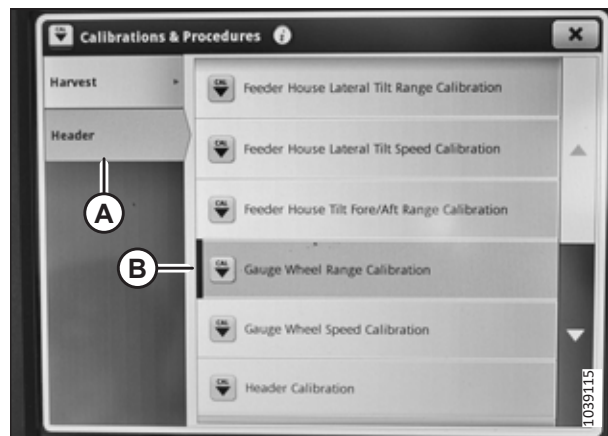

Figure 8.388: John Deere X9 Display – Gauge Wheel Range Calibration

SETTING UP AUTO HEADER HEIGHT CONTROL SYSTEM

17. Select HEADER CALIBRATION (A). The HEADER CALIBRATION page appears.

NOTE:

Unlock the mechanical float locks before calibrating the header.

18. Raise the header to the top of the feeder house range and ensure that both of the float indicators reach 0. Wait until the indicators stop moving before proceeding.
19. Lower the header until the float indicator reaches 4 and can go no further.
20. Raise the header again to the top of the feeder house range and ensure that both of the float indicators reach 0. Wait until the indicators stop moving before proceeding.
21. Select SAVE to confirm the calibration.
22. Select REEL AND CUTTERBAR POSITION CALIBRATION (A). The REEL AND CUTTERBAR POSITION CALIBRATION page appears.
23. Follow the instructions on the page. As you proceed through the calibration process, the display will automatically update to show the next step.
24. Select SAVE.
25. Press the X in the top right corner to exit the CALIBRATION & PROCEDURES page.

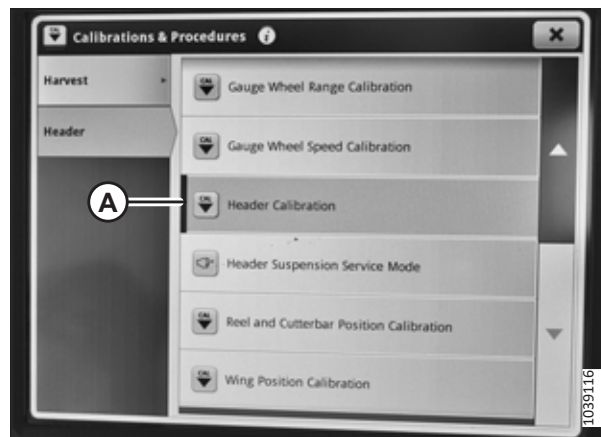

Figure 8.389: John Deere X9 Display – Header Calibration

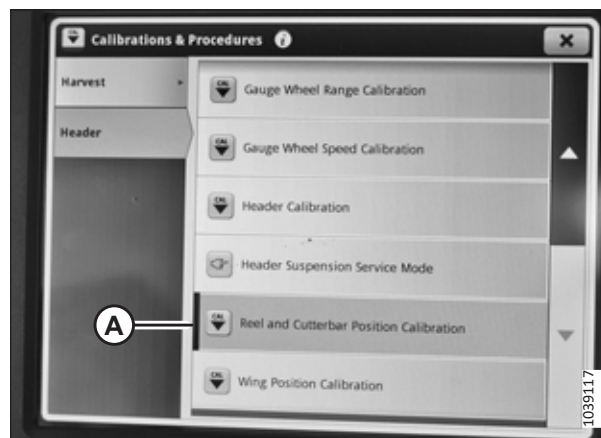

Figure 8.390: John Deere X9 Display – Reel and Cutterbar Position Calibration

Checking Voltage Range from Combine Cab – John Deere X9 Series

The voltage of the auto header height control (AHHC) sensors will need to be verified to ensure the proper operation of the system.

NOTE:

Changes may have been made to the combine controls or the display since this document was published. For the most up-to-date information, refer to the combine operator's manual.

⚠ DANGER

To prevent bodily injury or death from the unexpected start-up of the machine, always stop the engine and remove the key from the ignition before making adjustments to the machine.

⚠ DANGER

Ensure that all bystanders have cleared the area.

SETTING UP AUTO HEADER HEIGHT CONTROL SYSTEM

1. Position the header so that the cutterbar is 254–356 mm (10–14 in.) off the ground.
2. Shut down the engine, and remove the key from the ignition.
3. Unlock the header float. For instructions, refer to the header operator's manual.

CAUTION

To prevent cuts, pinches, and other bodily harm to the person checking the down stops, ensure that nobody is manually lifting, bouncing, or moving the header in any way while the down stop washer is being touched and checked for movement.

4. Ensure that the float lock linkage is on the down stops (washer [A] cannot move) at both locations.

NOTE:

If the header is **NOT** on the down stops, the voltage may go out of range during operation and cause the AHHC system to malfunction. To fix the problem, make the header heavier by decreasing the float. For instructions, refer to [6.10 Checking and Adjusting Header Float](#), page 229.

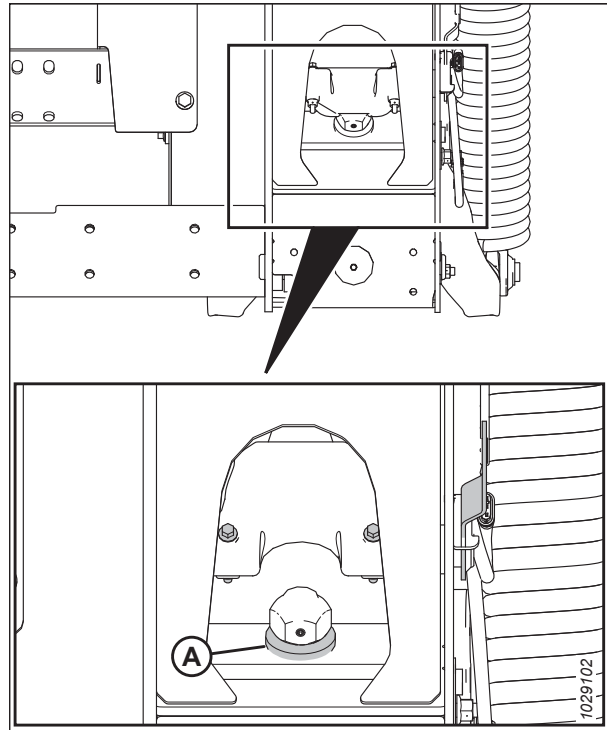

Figure 8.391: Down Stop Washer

5. If the pointer is not on zero, loosen bolt (A) and slide float indicator plate (B) until pointer (C) is on 0 (D). Tighten the nut on bolt (A).

NOTE:

Use zero dot (E) above the decal to correctly set the indicator needle.

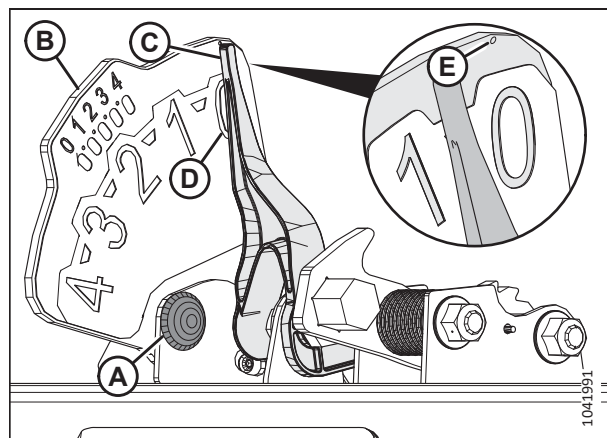

Figure 8.392: Float Indicator

SETTING UP AUTO HEADER HEIGHT CONTROL SYSTEM

- On the HARVESTING page, select MENU icon (A) in the bottom right corner of the page. The MENU appears.



Figure 8.393: John Deere X9 Display – Harvesting Page

- Select SYSTEM tab (A), and then select DIAGNOSTICS CENTER (B).



Figure 8.394: John Deere X9 Display – System

- Select CONTROLLERS tab (A).
- Select HEADER/HITCH CONTROLLER (B).

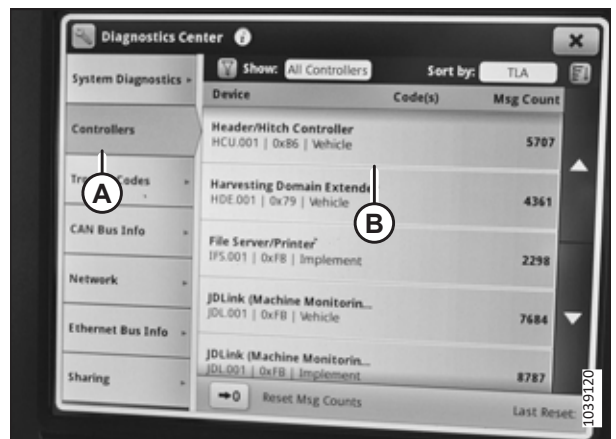

Figure 8.395: John Deere X9 Display – Diagnostics Center

SETTING UP AUTO HEADER HEIGHT CONTROL SYSTEM

10. Select READINGS (A) on the display and scroll through list (B) to find the desired voltage reading. For information on the appropriate voltage range, refer to [8.1.2 Recommended Sensor Output Voltages for Combines, page 268](#).
11. Press the X in the top right corner to exit the HEADER/HITCH CONTROLLER page.
12. If the sensor voltage is not within the lower and upper limits, or if the range between the lower and upper limits is insufficient, refer to [8.1.3 Manually Checking Voltage Limits, page 269](#).

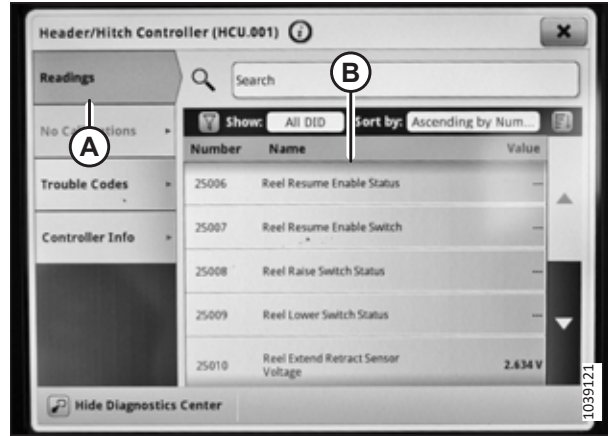

Figure 8.396: John Deere X9 Display – Header/Hitch Controller

Using Auto Header Height Control – John Deere X9 Series

The ground speed lever in the cab of the combine has three buttons which can be used to control the auto header height control (AHHC) system.

DANGER

Ensure that all bystanders have cleared the area.

NOTE:

Changes may have been made to the combine controls or the display since this document was published. For the most up-to-date information, refer to the combine operator's manual.

1. Start the engine.
2. Press HEADER button (A) on the panel below the display. The HEADER page opens.



Figure 8.397: CommandCenter™ Display

SETTING UP AUTO HEADER HEIGHT CONTROL SYSTEM

3. Select AUTO CONTROL (A). The AUTO HEADER CONTROLS page opens.

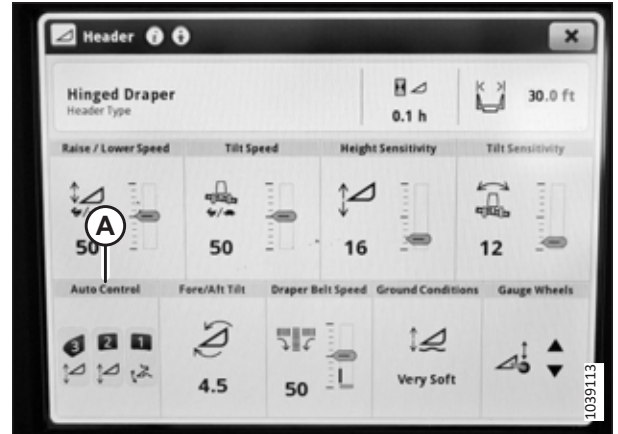

Figure 8.398: CommandCenter™ Display – Auto Header Controls Page

4. On the AUTO HEADER CONTROLS page, locate CONTROL PREVIEW (A).

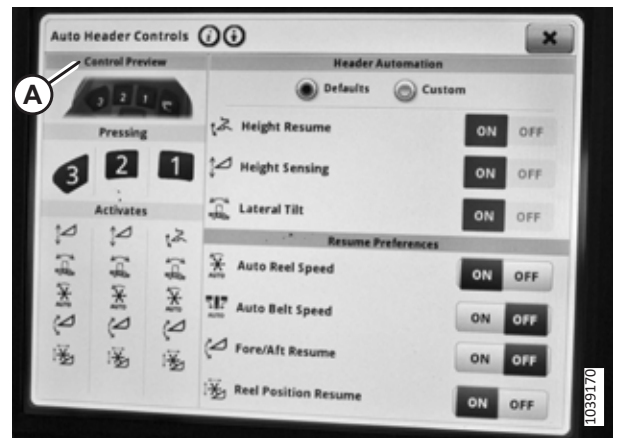

Figure 8.399: John Deere X9 Display – Auto Header Controls Page

NOTE:

When buttons 2 or 3 (A) on the multifunction lever are pressed, the system automatically moves the header to the preset setting. The preset setting can be set by the Operator.

NOTE:

Below each button on the display is a list of functions that the button will operate.

NOTE:

Button 1 is used for the RETURN TO HEIGHT function.



Figure 8.400: John Deere X9 – Multifunction Lever

SETTING UP AUTO HEADER HEIGHT CONTROL SYSTEM

5. Press button 2 or 3 (B) on the multifunction lever to set the reel position.
6. Press button (A) to adjust the reel fore-aft and reel height positions. Hold the button for 3 seconds to save the setting. This will become the preset reel setting for button 2 or 3.

NOTE:

Buttons 2 and 3 can have different settings.



Figure 8.401: John Deere X9 – Multifunction Lever

Checking Error Codes on Header Controller – John Deere X9 Series

If errors occur while the auto header height control (AHHC) system is operating, the resulting error codes can be viewed in the combine computer's DIAGNOSTICS CENTER.

DANGER

Ensure that all bystanders have cleared the area.

NOTE:

Changes may have been made to the combine controls or the display since this document was published. For the most up-to-date information, refer to the combine operator's manual.

1. Start the engine.
2. On the HARVESTING page, select MENU icon (A) in the bottom right corner of the page. The MENU appears.



Figure 8.402: John Deere X9 Display – Harvesting Page

SETTING UP AUTO HEADER HEIGHT CONTROL SYSTEM

3. Select SYSTEM tab (A), and then select DIAGNOSTICS CENTER (B).



Figure 8.403: John Deere X9 Display – System

4. Select CONTROLLERS tab (A).
5. Select HEADER/HITCH CONTROLLER (B).

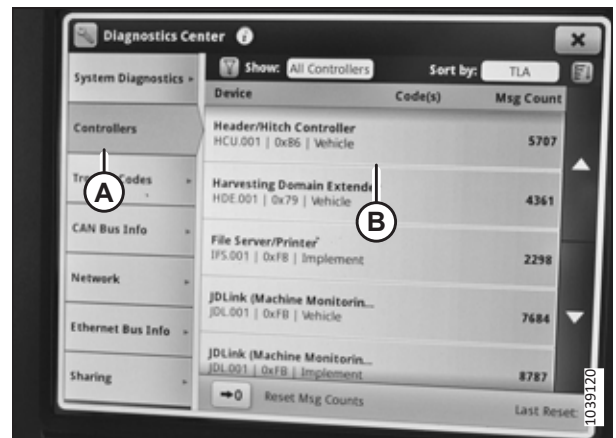

Figure 8.404: John Deere X9 Display – Diagnostics Center

6. Select TROUBLE CODES (A). Trouble codes appear on right side (B) of the display.
7. Press the X in the top right corner to exit the HEADER/HITCH CONTROLLER page.

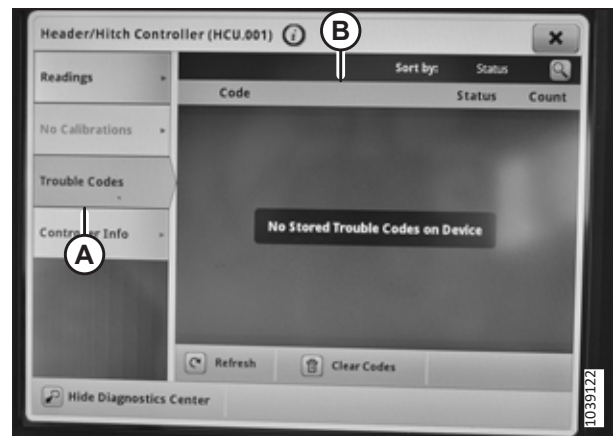

Figure 8.405: John Deere X9 Display – Header/Hitch Controller

Reel Reverse Function – John Deere X9 Series

You can allow the reel to reverse with the feeder house on the combine.

! DANGER

Ensure that all bystanders have cleared the area.

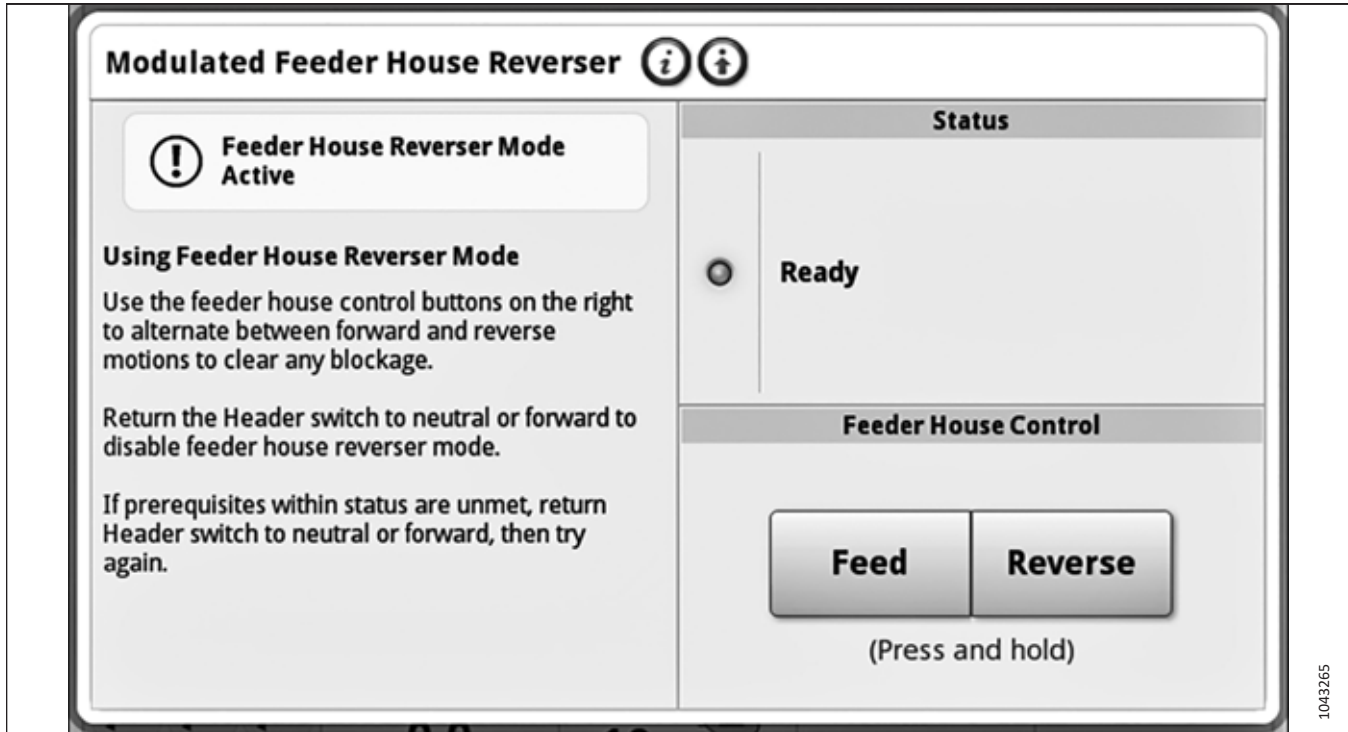

Figure 8.406: John Deere X9 Series Display

The reel can be operated in reverse using the feeder house reverser controls. For instructions and the most up-to-date information, refer to the combine operator’s manual.

NOTE:

The feeder house reverser controls can operate any float module from model year 2024 and later out-of-factory. Float modules from model year 2023 and prior require Reel Reverse Kit (B7543) before the feeder house reverser controls can be used.

Checking Software Version of Header Controller – John Deere X9 Series

The software version of the header controller on the combine can be viewed in the CommandCenter™ display’s DIAGNOSTICS CENTER.

! DANGER

Ensure that all bystanders have cleared the area.

NOTE:

Changes may have been made to the combine controls or the display since this document was published. For the most up-to-date information, refer to the combine operator’s manual.

SETTING UP AUTO HEADER HEIGHT CONTROL SYSTEM

1. Start the engine.
2. On the HARVESTING page, select MENU icon (A) in the bottom right corner of the page. The MENU appears.



Figure 8.407: John Deere X9 Display – Harvesting Page

3. Select SYSTEM tab (A), and then select DIAGNOSTICS CENTER (B).



Figure 8.408: John Deere X9 Display – System

4. Select CONTROLLERS tab (A).
5. Select HEADER/HITCH CONTROLLER (B).

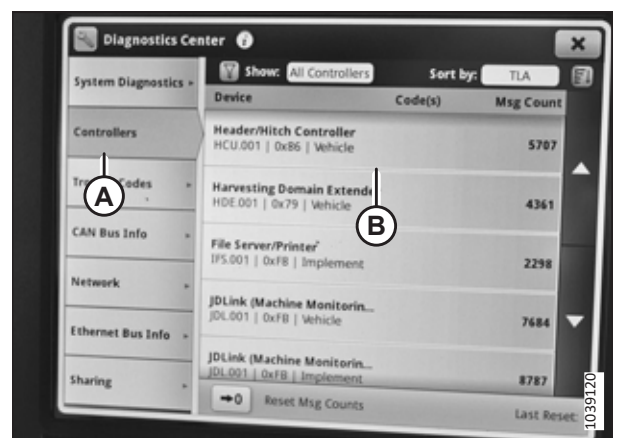

Figure 8.409: John Deere X9 Display – Diagnostics Center

SETTING UP AUTO HEADER HEIGHT CONTROL SYSTEM

6. Select CONTROLLER INFO (A). Locate SOFTWARE MAIN COMPONENT (B).
7. Select the X in the top right corner to exit the HEADER/HITCH CONTROLLER page.

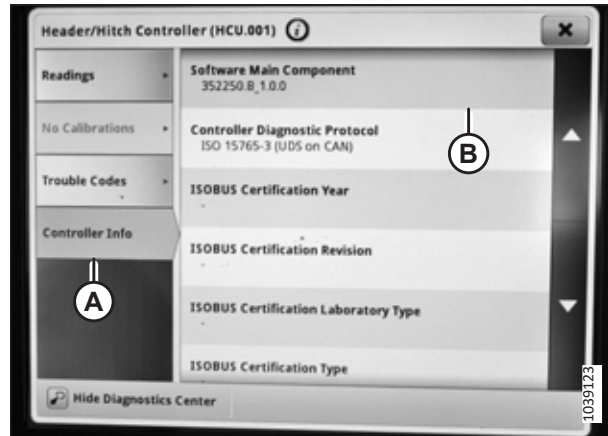

Figure 8.410: John Deere X9 Display – Header/Hitch Controller

8.1.19 New Holland CR and CX Series Combines – 2014 and Earlier

To make your header's auto header height control (AHHC) system compatible with the combine, you must set your combine's header configuration options for the particular model of header, configure the reel speed settings, set up the AHHC controls, and calibrate the AHHC system to ensure that it is working correctly.

Checking Voltage Range from Combine Cab – New Holland CR and CX Series

The auto header height control (AHHC) sensor needs to operate in a specific voltage range in order to work properly.

NOTE:

For New Holland CR models 6.80, 6.90, 7.90, 8.90, 9.90, and 10.90, refer to [8.1.20 New Holland Combines – CR Series \(2015 and Later\) and CH, page 469](#).

NOTE:

Changes may have been made to the combine controls or the display since this document was published. For the most up-to-date information, refer to the combine operator's manual.

⚠ DANGER

To prevent bodily injury or death from the unexpected start-up of the machine, always stop the engine and remove the key from the ignition before making adjustments to the machine.

⚠ DANGER

Ensure that all bystanders have cleared the area.

1. Position the header so that the cutterbar is 254–356 mm (10–14 in.) off the ground.
2. Shut down the engine, and remove the key from the ignition.
3. Unlock the header float. For instructions, refer to the header operator's manual.

SETTING UP AUTO HEADER HEIGHT CONTROL SYSTEM

CAUTION

To prevent cuts, pinches, and other bodily harm to the person checking the down stops, ensure that nobody is manually lifting, bouncing, or moving the header in any way while the down stop washer is being touched and checked for movement.

4. Ensure that the float lock linkage is on the down stops (washer [A] cannot move) at both locations.

NOTE:

If the header is **NOT** on the down stops, the voltage may go out of range during operation and cause the AHHC system to malfunction. To fix the problem, make the header heavier by decreasing the float. For instructions, refer to [6.10 Checking and Adjusting Header Float, page 229](#).

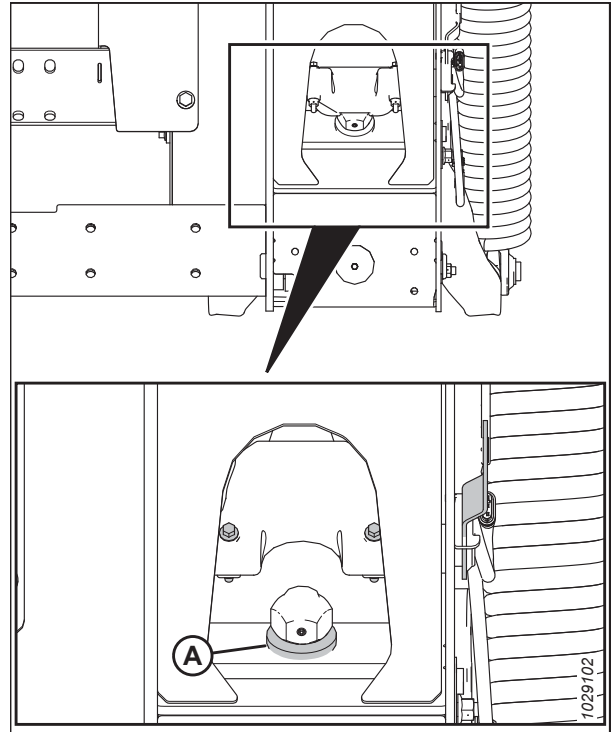

Figure 8.411: Down Stop Washer

5. If the pointer is not on zero, loosen bolt (A) and slide float indicator plate (B) until pointer (C) is on 0 (D). Tighten the nut on bolt (A).

NOTE:

Use zero dot (E) above the decal to correctly set the indicator needle.

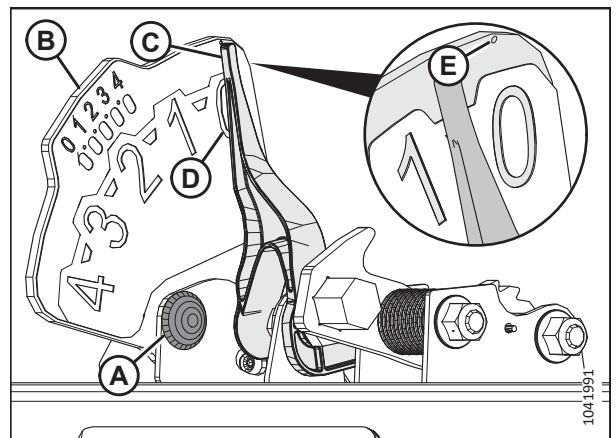

Figure 8.412: Float Indicator

SETTING UP AUTO HEADER HEIGHT CONTROL SYSTEM

6. Ensure that the header float is unlocked.
7. Select DIAGNOSTICS (A) on the main page. The DIAGNOSTICS page appears.
8. Select SETTINGS. The SETTINGS page appears.

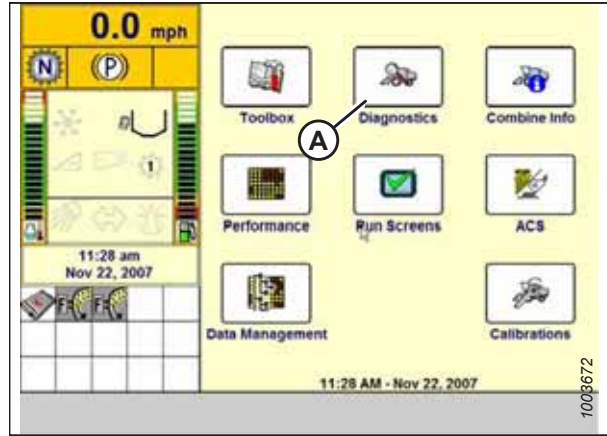

Figure 8.413: New Holland Combine Display

9. Select GROUP drop-down menu (A). The GROUP dialog box appears.

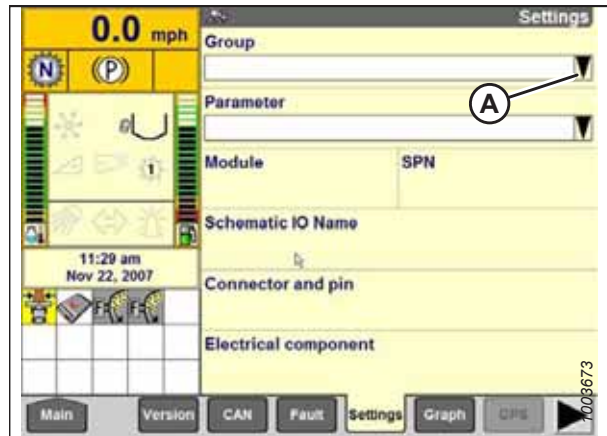

Figure 8.414: New Holland Combine Display

10. Select HEADER HEIGHT/TILT (A). The PARAMETER page appears.

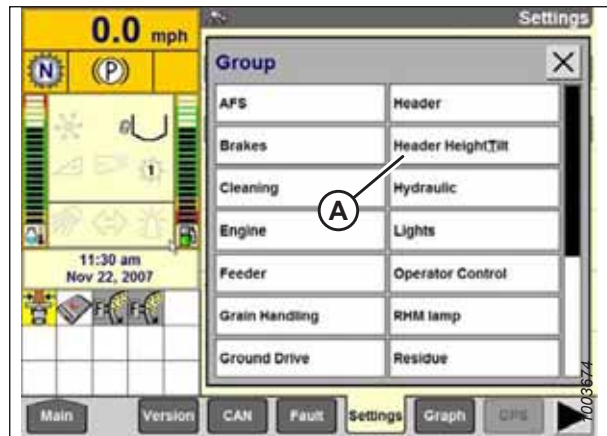

Figure 8.415: New Holland Combine Display

SETTING UP AUTO HEADER HEIGHT CONTROL SYSTEM

11. Select LEFT HEADER HEIGHT SEN (A), then select GRAPH button (B). The voltage reading appears at the top of the page.
12. Raise and lower the header to see the full range of voltage readings.
13. Compare the voltage readings on the display to voltage ranges specified in [8.1.2 Recommended Sensor Output Voltages for Combines, page 268](#).
14. If the sensor voltage is not within the lower and upper limits, or if the range between the lower and upper limits is insufficient, refer to [8.1.3 Manually Checking Voltage Limits, page 269](#).

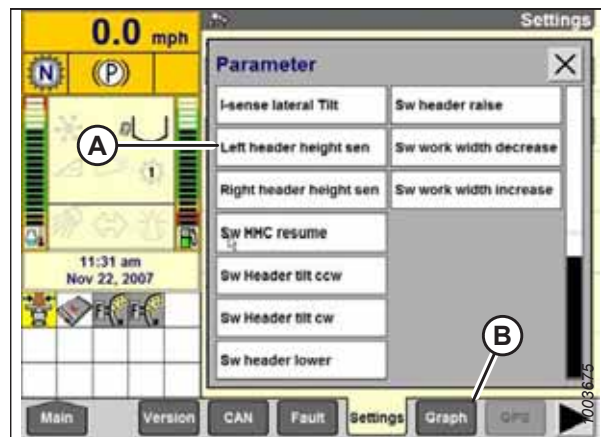

Figure 8.416: New Holland Combine Display

Header Settings Quick Reference – New Holland CR Series

Use the information in the following table to quickly reference the recommended settings for a header paired with a New Holland CR Series combine.

NOTE:

Changes may have been made to the combine controls or the display since this document was published. For the most up-to-date information, refer to the combine operator's manual.

Table 8.8 Header Settings – New Holland CR Series

Setup Parameter	Suggested Setting
Cutting type	Platform
Header sub type	80/90
Autofloat	Installed
Auto header lift	Installed
Manual HHC raise/lower rate	Set for best performance
HHC height sensitivity	Set for best performance
HHC tilt sensitivity	Set for best performance
Reel height sensor	Yes

Setting up Auto Header Height Control – New Holland CR and CX Series

Use the combine display to set up the auto header height control (AHHC) system.

NOTE:

Changes may have been made to the combine controls or the display since this document was published. For the most up-to-date information, refer to the combine operator's manual.

NOTE:

For New Holland CR models 6.80, 6.90, 7.90, 8.90, 9.90, and 10.90, refer to [8.1.20 New Holland Combines – CR Series \(2015 and Later\) and CH, page 469](#).

SETTING UP AUTO HEADER HEIGHT CONTROL SYSTEM

1. Select HEADER LATERAL FLOAT on the combine display, and press ENTER.
2. Use the up and down navigation keys to select INSTALLED.



Figure 8.417: New Holland Combine Display

3. Select HEADER AUTOFLOAT, and press ENTER.
4. Use the up and down navigation keys to move between options, and select INSTALLED.

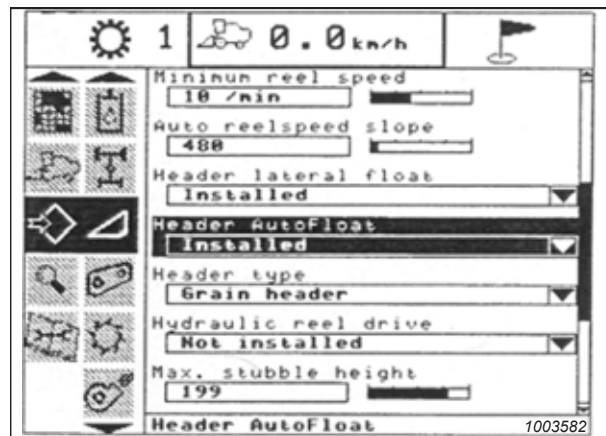

Figure 8.418: New Holland Combine Display

Calibrating Auto Header Height Control – New Holland CR and CX Series

The auto header height control (AHHC) sensor output must be calibrated for each combine.

NOTE:

For New Holland CR models 6.80, 6.90, 7.90, 8.90, 9.90, and 10.90, refer to [8.1.20 New Holland Combines – CR Series \(2015 and Later\) and CH, page 469](#).

! DANGER

To prevent bodily injury or death from the unexpected start-up of the machine, always stop the engine and remove the key from the ignition before making adjustments to the machine.

! DANGER

Ensure that all bystanders have cleared the area.

NOTE:

Changes may have been made to the combine controls or the display since this document was published. For the most up-to-date information, refer to the combine operator's manual.

SETTING UP AUTO HEADER HEIGHT CONTROL SYSTEM

NOTE:

If the header float is set too light, it can prevent the calibration of the AHHC. In order to prevent the header from separating from the float module, it may be necessary to change the float to a heavier setting during calibration.

1. Park the combine on a level surface.
2. Ensure that the header is level with the ground. If adjustment is required, refer to [10.5 Leveling Header, page 526](#).

NOTE:

Spirit level (A) is located on top of the float module frame. The header is level if the bubble is in the center of the spirit level.

3. Ensure that the center-link is set to **D**.

NOTE:

When calibration is complete, adjust the center-link back to the desired header angle. For instructions, refer to the header operator's manual.

4. Adjust the reel fore-aft position so that the indicator is at position **6**.
5. Position the header so that the cutterbar is 254–356 mm (10–14 in.) off the ground.
6. Shut down the engine, and remove the key from the ignition.

CAUTION

To prevent cuts, pinches, and other bodily harm to the person checking the down stops, ensure that nobody is manually lifting, bouncing, or moving the header in any way while the down stop washer is being touched and checked for movement.

7. Ensure that the float lock linkage is on the down stops (washer [A] cannot move) at both locations.

NOTE:

If the header is **NOT** on the down stops, the voltage may go out of range during operation and cause the AHHC system to malfunction. To fix the problem, make the header heavier by decreasing the float. For instructions, refer to [6.10 Checking and Adjusting Header Float, page 229](#).

8. Unlock the header float. For instructions, refer to the header operator's manual.

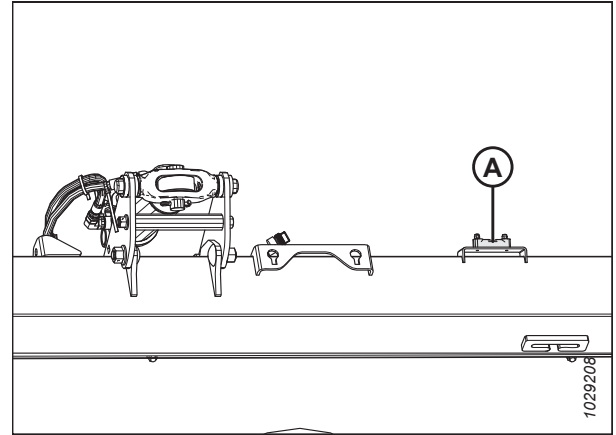

Figure 8.419: Spirit Level

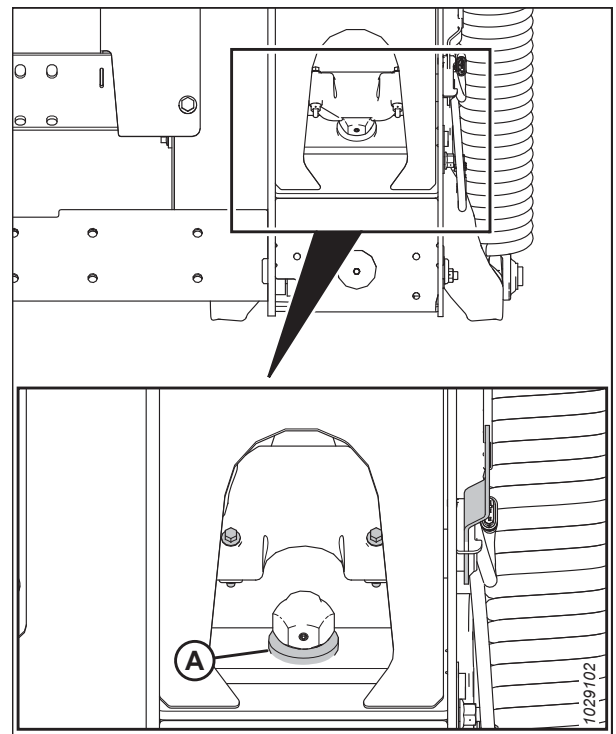

Figure 8.420: Down Stop Washer

SETTING UP AUTO HEADER HEIGHT CONTROL SYSTEM

To calibrate the AHHC, follow these steps:

9. Select CALIBRATION on the combine display, and press the RIGHT ARROW navigation key to enter the information box.
10. Select HEADER (A), and press ENTER. The CALIBRATION window opens.

NOTE:

You can use the up and down navigation keys to move between the options.

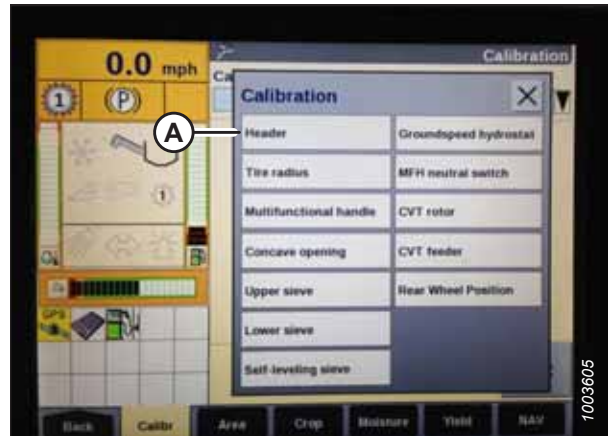

Figure 8.421: New Holland Combine Display

11. Follow the steps in the order in which they appear in the window. As you proceed through the calibration process, the display will automatically update to show the next step.

NOTE:

Pressing the ESC key during any of the steps or letting the system sit idle for more than 3 minutes will stop the calibration procedure.

NOTE:

Refer to your combine operator's manual for an explanation of any error codes.



Figure 8.422: New Holland Combine Display

12. When all of the steps have been completed, a CALIBRATION SUCCESSFUL message will appear on the screen. Exit the CALIBRATION menu by pressing the ENTER or ESC key.

NOTE:

If the float was set heavier to complete the AHHC calibration procedure, adjust it to the recommended operating float after the calibration is complete.

13. If the unit does not function properly, conduct the maximum stubble height calibration. For instructions, refer to [Calibrating Maximum Stubble Height – New Holland CR and CX Series, page 464.](#)

Calibrating Maximum Stubble Height – New Holland CR and CX Series

This procedure details how to set the height at which the harvest area counter will start and stop counting harvested area.

NOTE:

Changes may have been made to the combine controls or the display since this document was published. For the most up-to-date information, refer to the combine operator's manual.

SETTING UP AUTO HEADER HEIGHT CONTROL SYSTEM

IMPORTANT:

- If the value is set too low, the area counter may **NOT** be accurate since the header is sometimes raised above this threshold although the combine is still cutting.
- If the value is set too high, the area counter will keep counting even when the header is raised (but below this threshold) and the combine is no longer cutting crop.

DANGER

Ensure that all bystanders have cleared the area.

1. Select the MAXIMUM STUBBLE HEIGHT calibration dialog box. As you proceed through the calibration process, the display automatically updates to show the next step.

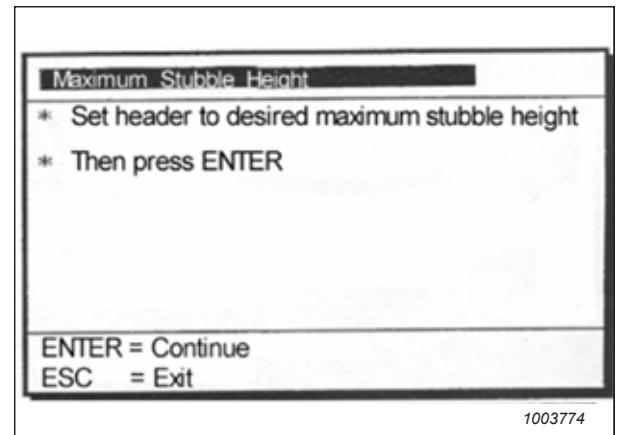

Figure 8.423: New Holland Calibration Dialog Box

2. Move the header to the desired maximum stubble height by using the control switch on the multifunction handle.

NOTE:

Set the header to a height which will never be attained while harvesting. This will ensure that the harvest area counter never stops recording harvesting data while the auto header height control (AHHC) system is active.

3. Press ENTER to continue. As you proceed through the calibration process, the display automatically updates to show the next step.
4. Press ENTER or ESC to close the calibration screen. The calibration is now complete.

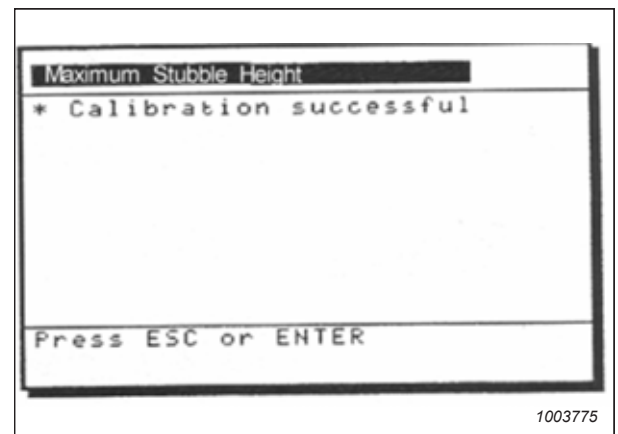

Figure 8.424: New Holland Calibration Dialog Box

Adjusting Header Raise Rate – New Holland CR and CX Series

If necessary, the header raise rate (the first speed on the HEADER HEIGHT rocker switch of the multifunction handle) can be adjusted.

NOTE:

Changes may have been made to the combine controls or the display since this document was published. For the most up-to-date information, refer to the combine operator's manual.

DANGER

Ensure that all bystanders have cleared the area.

SETTING UP AUTO HEADER HEIGHT CONTROL SYSTEM

NOTE:

For New Holland CR models 6.80, 6.90, 7.90, 8.90, 9.90, and 10.90, refer to *8.1.20 New Holland Combines – CR Series (2015 and Later) and CH, page 469*.

1. Select HEADER RAISE RATE on the combine display.
2. Use the + or – buttons to change the setting.
3. Press ENTER to save the new setting.

NOTE:

The raise rate can be changed from 32–236 in increments of 34. The factory setting is 100.

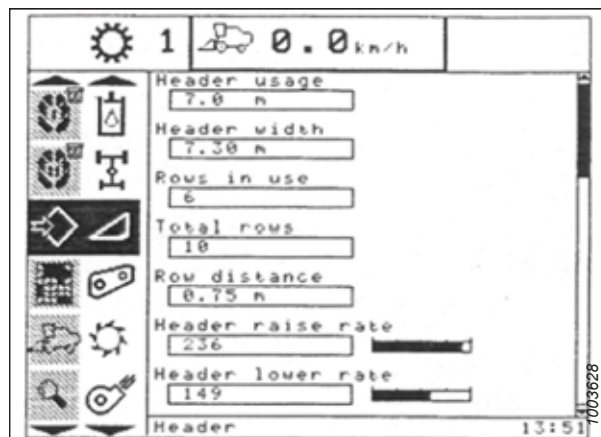

Figure 8.425: New Holland Combine Display

Adjusting Header Lower Rate – New Holland CR and CX Series

If necessary, the header lower rate (the automatic header height control button or second speed on the header height rocker switch of the multifunction handle) can be adjusted.

NOTE:

Changes may have been made to the combine controls or the display since this document was published. For the most up-to-date information, refer to the combine operator's manual.

DANGER

Ensure that all bystanders have cleared the area.

NOTE:

For New Holland CR models 6.80, 6.90, 7.90, 8.90, 9.90, and 10.90, refer to *8.1.20 New Holland Combines – CR Series (2015 and Later) and CH, page 469*.

1. Select HEADER LOWER RATE on the combine display.
2. Use the + or – buttons to change the setting to 50.
3. Press ENTER to save the new setting.

NOTE:

The header lower rate can be changed from 2–247 in increments of 7. It is factory-set to 100.

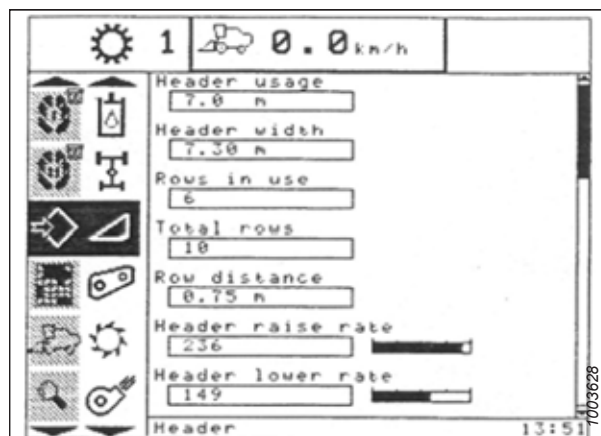

Figure 8.426: New Holland Combine Display

SETTING UP AUTO HEADER HEIGHT CONTROL SYSTEM

Setting Auto Header Height Control Sensitivity – New Holland CR and CX Series

The sensitivity adjustment controls the distance the cutterbar must travel up or down before the auto header height control (AHC) reacts and raises or lowers the feeder house.

When the sensitivity is set to maximum, only small changes in ground height raise or lower the feeder house. When the sensitivity is set to minimum, large changes in the ground height are needed to raise or lower the feeder house.

NOTE:

Changes may have been made to the combine controls or the display since this document was published. For the most up-to-date information, refer to the combine operator's manual.

NOTE:

For New Holland CR models 6.80, 6.90, 7.90, 8.90, 9.90, and 10.90, refer to [8.1.20 New Holland Combines – CR Series \(2015 and Later\) and CH, page 469](#).

DANGER

Ensure that all bystanders have cleared the area.

1. Engage the threshing mechanism and the feeder house.
2. Select HEIGHT SENSITIVITY on the combine display.
3. Use the + or – buttons to change the setting to 200.
4. Press ENTER to save the new setting.

NOTE:

The sensitivity can be changed from 10–250 in increments of 10. It is factory-set to 100.



Figure 8.427: New Holland Combine Display

Setting Preset Cutting Height – New Holland CR and CX Series

The reel and cut height setting can be stored in the combine's computer as presets. These settings can be set and selected using the combine's control console.

NOTE:

Changes may have been made to the combine controls or the display since this document was published. For the most up-to-date information, refer to the combine operator's manual.

NOTE:

For New Holland CR models 6.80, 6.90, 7.90, 8.90, 9.90, and 10.90, refer to [8.1.20 New Holland Combines – CR Series \(2015 and Later\) and CH, page 469](#).

SETTING UP AUTO HEADER HEIGHT CONTROL SYSTEM

NOTE:

Indicator (A) should be at position 0 (B) with the header 254–356 mm (10–14 in.) off the ground. When the header is on the ground, the indicator should be at position 1 (C) for low ground pressure, and at position 4 (D) for high ground pressure. Crop and soil conditions determine the amount of float to use. The ideal setting is as light as possible without header bouncing or missing crop. Operating with heavy settings prematurely wears the cutterbar wearplates.

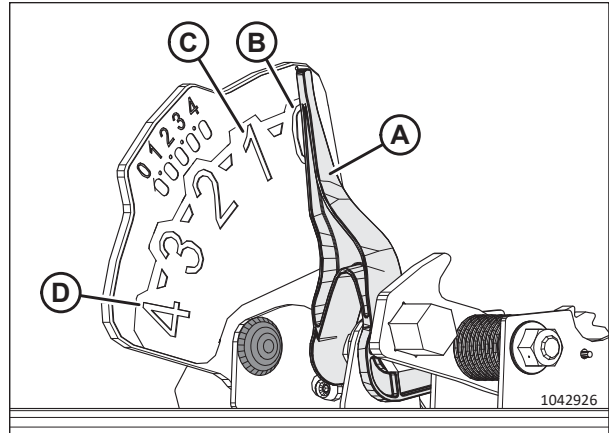

Figure 8.428: Float Indicator

1. Engage the threshing mechanism and the feeder house with switches (A) and (B).
2. Set HEADER MEMORY rocker switch (D) in STUBBLE HEIGHT/AUTOFLOAT mode position (A) or (B).
3. Raise or lower the header to the desired cutting height using HEADER HEIGHT and HEADER LATERAL FLOAT momentary switch (C).
4. Lightly press AUTOMATIC HEADER HEIGHT CONTROL button (E) for a minimum of 2 seconds to store the height position. A beep confirms the setting.

NOTE:

It is possible to store two different header height values by using HEADER MEMORY rocker switch (D) in STUBBLE HEIGHT/AUTOFLOAT mode position (A) or (B).

5. Raise or lower the reel to the desired working height using the REEL HEIGHT momentary switch.
6. Lightly press AUTOMATIC HEADER HEIGHT CONTROL button (E) for a minimum of 2 seconds to store the height position. A beep confirms the setting.

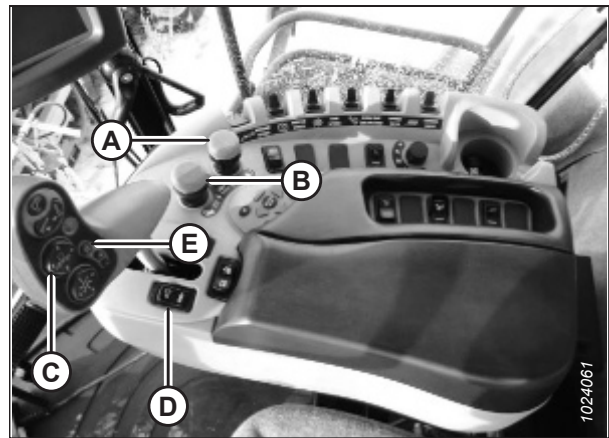

Figure 8.429: New Holland Combine Controls

SETTING UP AUTO HEADER HEIGHT CONTROL SYSTEM

- To change one of the memorized header height set points while the combine is in use, use HEADER HEIGHT AND HEADER LATERAL FLOAT rocker switch (A) (slow up/down) to raise or lower header to the desired value. Lightly press AUTOMATIC HEADER HEIGHT CONTROL button (B) for a minimum of 2 seconds to store the new height position. A beep confirms setting.

NOTE:

Fully pressing AUTOMATIC HEADER HEIGHT CONTROL button (B) will disengage float mode.

NOTE:

It is not necessary to press rocker switch (C) again after changing header height set point.

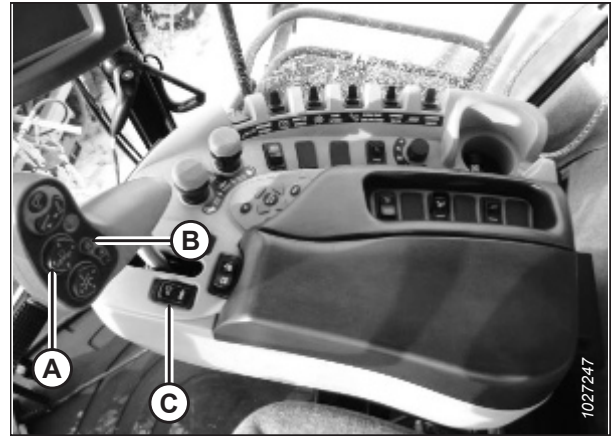

Figure 8.430: New Holland Combine Controls

8.1.20 New Holland Combines – CR Series (2015 and Later) and CH

To make your header's auto header height control (AHHC) system compatible with the combine, you must set your combine's header configuration options for the particular model of header, configure the reel speed settings, set up the AHHC controls, and calibrate the AHHC system to ensure that it is working correctly.

This section only applies to 2015 and later CR models (6.80, 6.90, 7.90, 8.90, 9.90, and 10.90).

Checking Voltage Range from Combine Cab – New Holland CR Series and CH

The auto header height control (AHHC) sensor needs to operate in a specific voltage range in order to work properly.

NOTE:

CR Series: This section applies only to 2015 and later CR models (6.80, 6.90, 7.90, 8.90, 9.90, and 10.90). For pre-2015 New Holland combine models, refer to [8.1.19 New Holland CR and CX Series Combines – 2014 and Earlier, page 458](#).

NOTE:

Changes may have been made to the combine controls or the display since this document was published. For the most up-to-date information, refer to the combine operator's manual.

⚠ DANGER

To prevent bodily injury or death from the unexpected start-up of the machine, always stop the engine and remove the key from the ignition before making adjustments to the machine.

⚠ DANGER

Ensure that all bystanders have cleared the area.

- Position the header so that the cutterbar is 254–356 mm (10–14 in.) off the ground.
- Shut down the engine, and remove the key from the ignition.
- Unlock the header float. For instructions, refer to the header operator's manual.

SETTING UP AUTO HEADER HEIGHT CONTROL SYSTEM

CAUTION

To prevent cuts, pinches, and other bodily harm to the person checking the down stops, ensure that nobody is manually lifting, bouncing, or moving the header in any way while the down stop washer is being touched and checked for movement.

4. Ensure that the float lock linkage is on the down stops (washer [A] cannot move) at both locations.

NOTE:

If the header is **NOT** on the down stops, the voltage may go out of range during operation and cause the AHHC system to malfunction. To fix the problem, make the header heavier by decreasing the float. For instructions, refer to [6.10 Checking and Adjusting Header Float, page 229](#).

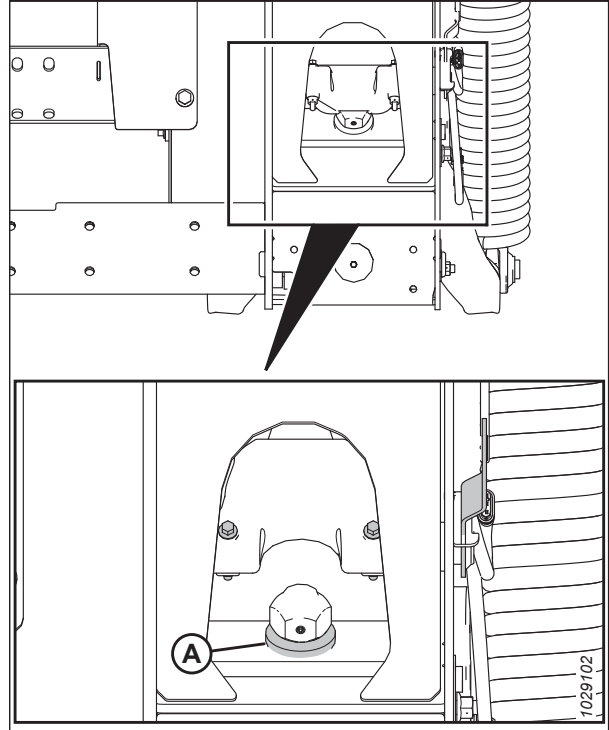

Figure 8.431: Down Stop Washer

5. If the pointer is not on zero, loosen bolt (A) and slide float indicator plate (B) until pointer (C) is on 0 (D). Tighten the nut on bolt (A).

NOTE:

Use zero dot (E) above the decal to correctly set the indicator needle.

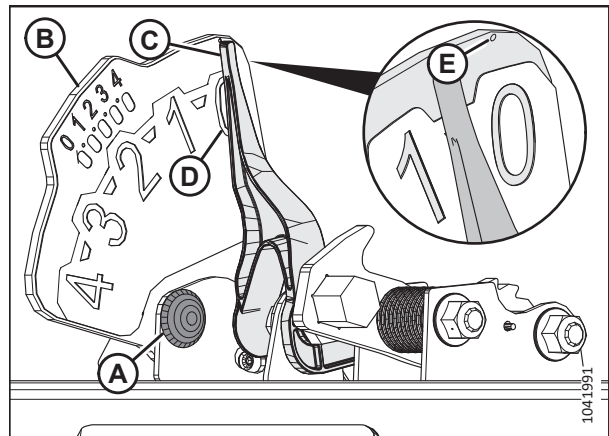

Figure 8.432: Float Indicator

SETTING UP AUTO HEADER HEIGHT CONTROL SYSTEM

6. Select DIAGNOSTICS icon (A) on the main page. The DIAGNOSTICS page appears.



Figure 8.433: New Holland Combine Display

7. Select SETTINGS tab (A). The SETTINGS page appears.



Figure 8.434: New Holland Combine Display

8. Select HEADER HEIGHT/TILT (A) from the GROUP drop-down menu.
9. Select HEADER HEIGHT SENS. L (B) from the PARAMETER drop-down menu.



Figure 8.435: New Holland Combine Display

SETTING UP AUTO HEADER HEIGHT CONTROL SYSTEM

10. Select GRAPH tab (A). The exact voltage (B) is displayed at the top of the page.
11. Raise and lower the header to see the full range of voltage readings.
12. If the sensor voltage is not within the lower and upper limits, or if the range between the lower and upper limits is insufficient, refer to [8.1.3 Manually Checking Voltage Limits](#), page 269.



Figure 8.436: New Holland Combine Display

Setting up Auto Header Height Control – New Holland CR Series and CH

Auto header height control (AHHC) is set up using the combine display and the control handle.

To ensure the best performance of the AHHC system, perform these procedures with the center-link set to **D**. When setup and calibration are complete, adjust the center-link back to the desired header angle.

NOTE:

Changes may have been made to the combine controls or the display since this document was published. For the most up-to-date information, refer to the combine operator's manual.

NOTE:

CR models: This section applies only to 2015 and later CR models (6.80, 6.90, 7.90, 8.90, 9.90, and 10.90). For other pre-2015 New Holland combine models, refer to [8.1.19 New Holland CR and CX Series Combines – 2014 and Earlier](#), page 458.

DANGER

Ensure that all bystanders have cleared the area.

1. Ensure that the center-link is set to **D**.
2. Shut down the engine.
3. Turn the ignition key to the RUN position.

SETTING UP AUTO HEADER HEIGHT CONTROL SYSTEM

4. Select TOOLBOX (A) on the main page. The TOOLBOX page appears.

IMPORTANT:

Some New Holland combines will not allow you to change the header settings from the main menu. This is now a dealer setting. If you cannot change the header settings from the main menu, contact your Dealer.



Figure 8.437: New Holland Combine Display

5. Select HEAD 1 (A). The HEADER SETUP 1 page displays.
6. Select CUTTING TYPE drop-down arrow (B) and change the CUTTING TYPE to PLATFORM (C).



Figure 8.438: New Holland Combine Display

7. Select HEADER SUB TYPE drop-down arrow, and set HEADER SUB TYPE to 80/90 (A).



Figure 8.439: New Holland Combine Display

SETTING UP AUTO HEADER HEIGHT CONTROL SYSTEM

8. Select HEAD 2 (A). The HEADER SETUP 2 page displays.



Figure 8.440: New Holland Combine Display

9. Select the AUTOFLOAT drop-down menu and set AUTOFLOAT to INSTALLED (A).
10. Select the AUTO HEADER LIFT drop-down menu and set AUTO HEADER LIFT to INSTALLED (B).

NOTE:

With AUTO HEADER LIFT installed and AHHC engaged, the header will lift up automatically when you pull back on the control handle.

11. Set the values for MANUAL HHC RAISE RATE (C) and MANUAL HHC LOWER RATE (D) for best performance according to ground conditions.



Figure 8.441: New Holland Combine Display

12. Set the values for HHC HEIGHT SENSITIVITY (A) and HHC TILT SENSITIVITY (B) for best performance according to ground conditions.



Figure 8.442: New Holland Combine Display

SETTING UP AUTO HEADER HEIGHT CONTROL SYSTEM

13. From REEL HEIGHT SENSOR menu (A), select YES.



Figure 8.443: New Holland Combine Display

Setting up Reel Speed – New Holland CR Series and CH

The reel diameter and the reel displacement settings will need to be entered into the combine's computer before the reel can be operated.

NOTE:

Changes may have been made to the combine controls or the display since this document was published. For the most up-to-date information, refer to the combine operator's manual.

NOTE:

CR models: This section applies only to 2015 and later CR models (6.80, 6.90, 7.90, 8.90, 9.90, and 10.90). For other pre-2015 New Holland combine models, refer to [8.1.19 New Holland CR and CX Series Combines – 2014 and Earlier, page 458](#).

1. Shut down the engine.
2. Turn the ignition key to the RUN position.
3. Ensure that the combine display software is updated to the relevant version specified below or later:
 - Combines from model years 2015–2018: UCM v38.10.0.0
 - Combines from model year 2019 or later: UCM v1.4.0.0
4. Ensure that the center-link is set to **D**.
5. Select TOOLBOX (A) on the main page. The TOOLBOX page appears.

IMPORTANT:

Some New Holland combines will not allow you to change the header settings from the main menu. This is now a dealer setting. If you cannot change the header settings from the main menu, contact your Dealer.

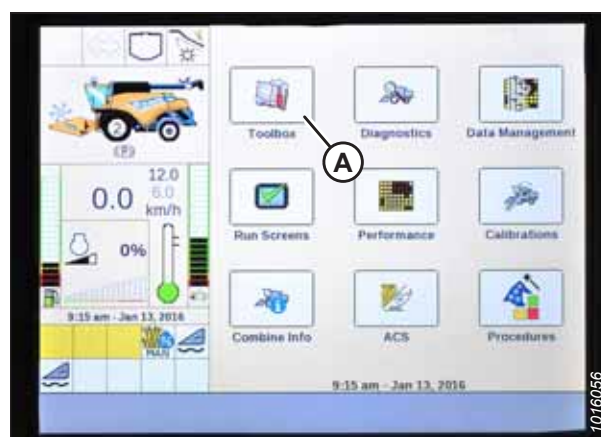

Figure 8.444: New Holland Combine Display

SETTING UP AUTO HEADER HEIGHT CONTROL SYSTEM

6. Select HEAD 2 (A). The HEADER SETUP 2 page appears.
7. Select REEL DIAMETER (B) and enter 102 cm (40.16 in).
8. Select REEL DISPLACEMENT PER REVOLUTION (C) and enter the appropriate value according to the specific combination of drive and driven sprocket sizes detailed in Table 8.9, page 476.

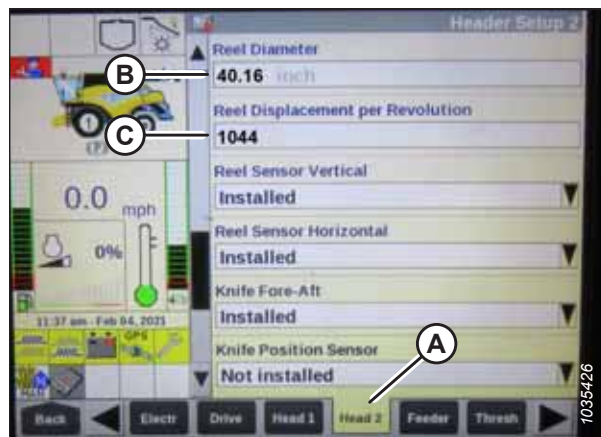

Figure 8.445: New Holland Combine Display

Table 8.9 Reel Displacement per Revolution Chart

Drive Sprocket Size (Number of Teeth)	Driven Sprocket Size (Number of Teeth)	Reel Displacement Per Revolution
19 (standard)	56	769
14 (high torque / low speed) ²⁶	56	1044
20 (low torque / high speed) ²⁷	52	679

Calibrating Auto Header Height Control – New Holland CR Series and CH

The auto header height control (AHHC) sensor output must be calibrated for each combine, or the AHHC feature will not work properly.

NOTE:

CR models: This section applies only to 2015 and later CR models (6.80, 6.90, 7.90, 8.90, 9.90, and 10.90). For other pre-2015 New Holland combine models, refer to [8.1.19 New Holland CR and CX Series Combines – 2014 and Earlier, page 458](#).

DANGER

To prevent bodily injury or death from the unexpected start-up of the machine, always stop the engine and remove the key from the ignition before making adjustments to the machine.

DANGER

Ensure that all bystanders have cleared the area.

NOTE:

Changes may have been made to the combine controls or the display since this document was published. For the most up-to-date information, refer to the combine operator's manual.

NOTE:

If the header float is set too light, it can prevent the calibration of the AHHC. In order to prevent the header from separating from the float module, it may be necessary to change the float to a heavier setting during calibration.

26. Two speed kit with chain on inner sprockets.

27. Two speed kit with chain on outer sprockets.

SETTING UP AUTO HEADER HEIGHT CONTROL SYSTEM

1. Park the combine on a level surface.
2. Ensure that the header is level with the ground. If adjustment is required, refer to [10.5 Leveling Header, page 526](#).

NOTE:

Spirit level (A) is located on top of the float module frame. The header is level if the bubble is in the center of the spirit level.

3. Ensure that the center-link is set to **D**.

NOTE:

When calibration is complete, adjust the center-link back to the desired header angle. For instructions, refer to the header operator's manual.

4. Adjust the reel fore-aft position so that the indicator is at position **6**.
5. Position the header so that the cutterbar is 254–356 mm (10–14 in.) off the ground.
6. Shut down the engine, and remove the key from the ignition.



CAUTION

To prevent cuts, pinches, and other bodily harm to the person checking the down stops, ensure that nobody is manually lifting, bouncing, or moving the header in any way while the down stop washer is being touched and checked for movement.

7. Ensure that the float lock linkage is on the down stops (washer [A] cannot move) at both locations.

NOTE:

If the header is **NOT** on the down stops, the voltage may go out of range during operation and cause the AHHC system to malfunction. To fix the problem, make the header heavier by decreasing the float. For instructions, refer to [6.10 Checking and Adjusting Header Float, page 229](#).

8. Unlock the header float. For instructions, refer to the header operator's manual.

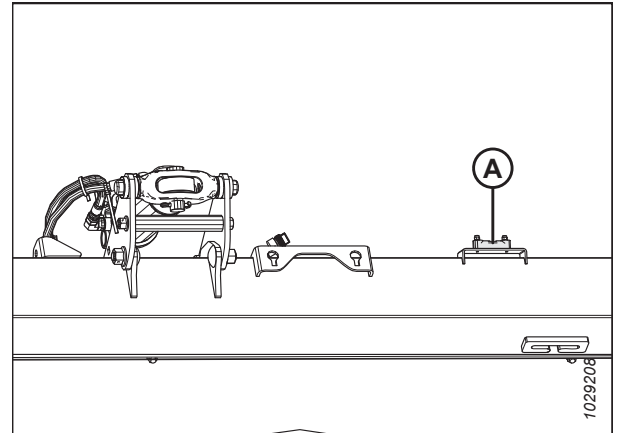

Figure 8.446: Spirit Level

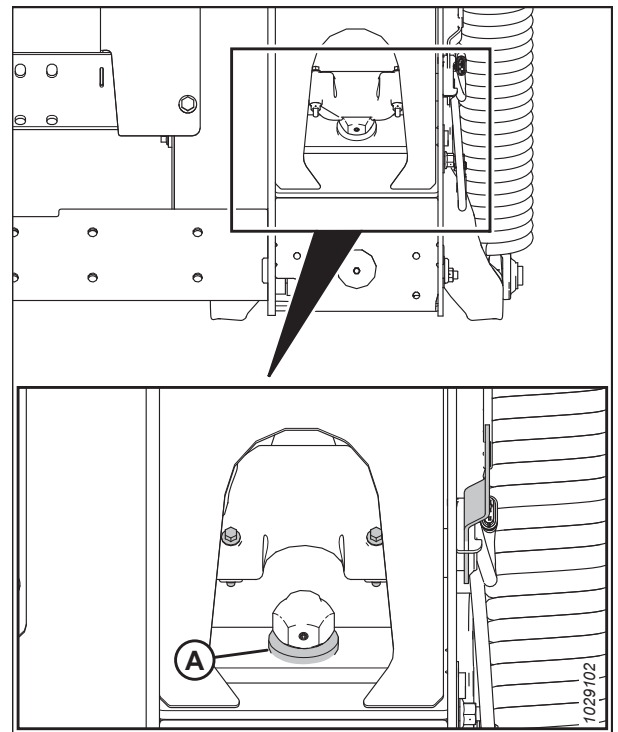

Figure 8.447: Down Stop Washer

SETTING UP AUTO HEADER HEIGHT CONTROL SYSTEM

To calibrate the AHHC, follow these steps:

9. Select CALIBRATIONS (A) on the main page. The CALIBRATION page appears.



Figure 8.448: New Holland Combine Display

10. Select CALIBRATION drop-down menu (A).



Figure 8.449: New Holland Combine Display

11. Select HEADER (A) from the list of calibration options.



Figure 8.450: New Holland Combine Display

SETTING UP AUTO HEADER HEIGHT CONTROL SYSTEM

- Follow the calibration steps in the order in which they appear on the page. As you proceed through the calibration process, the display updates to show the next step.

NOTE:

Pressing the ESC key during any of the steps or letting the system sit idle for more than 3 minutes stops the calibration procedure.

NOTE:

Refer to your combine operator's manual for an explanation of any error codes.



Figure 8.451: New Holland Combine Display

- When all steps have been completed, the CALIBRATION COMPLETED message appears on the page.

NOTE:

If the float was set heavier to complete AHHC calibration procedure, adjust it to the recommended operating float after the calibration is complete.



Figure 8.452: New Holland Combine Display

Calibrating Reel Height Sensor and Reel Fore-Aft Sensor – New Holland CR Series and CH

The reel height sensor and reel fore-aft sensor will need to be calibrated before the auto header height control (AHHC) system can be used. Calibrating the reel position calibrates the reel height sensor and the reel fore-aft sensor.

! DANGER

Ensure that all bystanders have cleared the area.

NOTE:

Changes may have been made to the combine controls or the display since this document was published. For the most up-to-date information, refer to the combine operator's manual.

NOTE:

CR models: This section applies only to 2015 and later CR models (6.80, 6.90, 7.90, 8.90, 9.90, and 10.90). For other pre-2015 New Holland combine models, refer to [8.1.19 New Holland CR and CX Series Combines – 2014 and Earlier, page 458](#).

SETTING UP AUTO HEADER HEIGHT CONTROL SYSTEM

To calibrate the reel position, follow these steps:

1. Start the engine.
2. Position the header 254–356 mm (10–14 in.) off the ground.

IMPORTANT:

Do **NOT** turn off the engine. The combine must be at a full idle to properly calibrate the sensors.

3. Select CALIBRATIONS (A) on the main page.
The CALIBRATION page appears.



Figure 8.453: New Holland Combine Display

4. Select CALIBRATION drop-down menu (A).



Figure 8.454: New Holland Combine Display

SETTING UP AUTO HEADER HEIGHT CONTROL SYSTEM

5. Select REEL POSITION (A) from the list of calibration options.

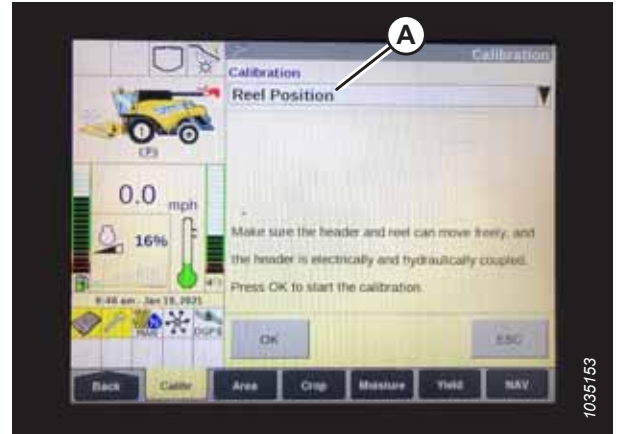

Figure 8.455: New Holland Combine Display

6. CAUTION statement (A) appears. Select ENTER.



Figure 8.456: New Holland Combine Display

7. If the statement "Confirm varifeed knife is completely retracted" (A) appears, select ENTER.

NOTE:

The varifeed knife is not applicable to MacDon headers.



Figure 8.457: New Holland Combine Display

SETTING UP AUTO HEADER HEIGHT CONTROL SYSTEM

- Follow calibration steps (A) as they appear on the page. As you proceed through the calibration process, the display automatically updates to show the next step.

NOTE:

Pressing the ESC key during any of the steps or letting the system sit idle for more than 3 minutes will stop the calibration procedure.

NOTE:

Refer to your combine operator's manual for an explanation of any error codes.



Figure 8.458: New Holland Combine Display

Checking Reel Height Sensor Voltages – New Holland CR Series and CH

Check the reel height sensor voltages to ensure that they are within the required range.

NOTE:

Changes may have been made to the combine controls or the display since this document was published. For the most up-to-date information, refer to the combine operator's manual.

- On the main page of the combine display, select DIAGNOSTICS (A). The DIAGNOSTICS page appears.



Figure 8.459: New Holland Combine Display

SETTING UP AUTO HEADER HEIGHT CONTROL SYSTEM

2. Select SETTINGS tab (A). The SETTINGS page appears.
3. From GROUP menu (B), select HEADER.
4. From PARAMETER menu (C), select REEL VERTICAL POSITION.

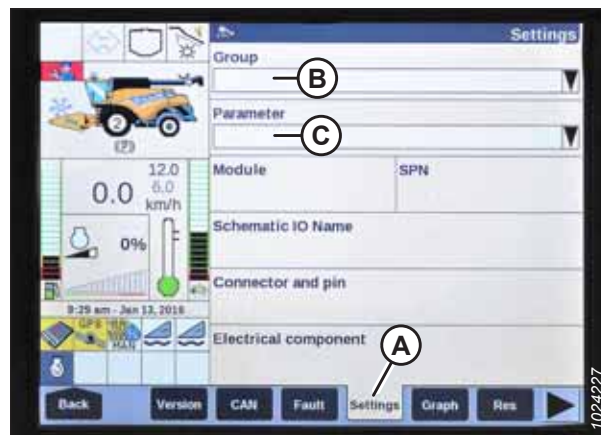

Figure 8.460: New Holland Combine Display

5. Select GRAPH tab (A). The REEL VERTICAL POSITION graph displays.
6. Raise the reel to view low voltage (C). The voltage should be within 0.7–1.1 V.
7. Lower the reel to view high voltage (B). The voltage should be within 3.9–4.3 V.
8. If either voltage is out of range, refer to [7.1 Checking and Adjusting Reel Height Sensor, page 259](#).

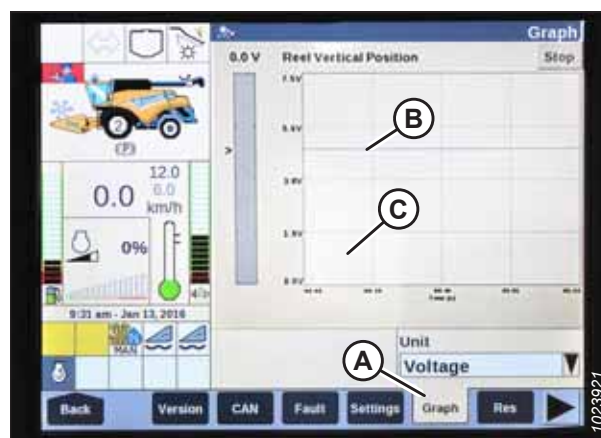

Figure 8.461: New Holland Combine Display

Setting Preset Cutting Height – New Holland CR Series and CH

The cut height setting can be stored in the combine. When harvesting, the setting can be selected from the control handle.

NOTE:

Changes may have been made to the combine controls or the display since this document was published. For the most up-to-date information, refer to the combine operator's manual.

NOTE:

CR models: This section applies only to 2015 and later CR models (6.80, 6.90, 7.90, 8.90, 9.90, and 10.90). For other pre-2015 New Holland combine models, refer to [8.1.19 New Holland CR and CX Series Combines – 2014 and Earlier, page 458](#).

SETTING UP AUTO HEADER HEIGHT CONTROL SYSTEM

The console has two buttons used for auto height presets. The toggle switch that was present on previous models is now configured as shown at right. MacDon headers only require first two buttons (A) and (B). Third button (C) is not configured.



Figure 8.462: New Holland Combine Controls

To set a preset cutting height, follow these steps:

DANGER

Ensure that all bystanders have cleared the area.

1. Engage the separator and the header.
2. Press preset button 1 (A). A yellow light on the button lights up.
3. Move the header to the desired cutting height.



Figure 8.463: New Holland Combine Controls

4. To set the preset, hold RESUME button (C) on the multifunction handle until the monitor beeps.

NOTE:

When setting presets, always set the header position before setting the reel position. If the header and the reel are set at the same time, the reel setting will not save.

5. Move the reel to the desired working position.
6. Hold RESUME button (C) on the multifunction handle to set the preset.
7. Repeat Step 2, page 484 to Step 6, page 484, using preset button 2.



Figure 8.464: New Holland Combine Multifunction Handle

SETTING UP AUTO HEADER HEIGHT CONTROL SYSTEM

- Lower the header to the ground.
- Select RUN SCREENS (A) on the main page.



Figure 8.465: New Holland Combine Display

- Select the RUN tab that shows MANUAL HEIGHT.

NOTE:

The MANUAL HEIGHT field may appear on any of the RUN tabs. When an auto height preset button is pressed, the display changes to AUTO HEIGHT (A).

- Press one of the auto height preset buttons to select a preset cutting height.



Figure 8.466: New Holland Combine Display

Setting Maximum Work Height – New Holland CR Series and CH

The maximum work height can be set using the combine display.

NOTE:

Changes may have been made to the combine controls or the display since this document was published. For the most up-to-date information, refer to the combine operator's manual.

NOTE:

CR models: This section applies only to 2015 and later CR models (6.80, 6.90, 7.90, 8.90, 9.90, and 10.90). For other pre-2015 New Holland combine models, refer to [8.1.19 New Holland CR and CX Series Combines – 2014 and Earlier, page 458](#).

SETTING UP AUTO HEADER HEIGHT CONTROL SYSTEM

1. Select TOOLBOX (A) on the main page. The TOOLBOX page appears.



Figure 8.467: New Holland Combine Display

2. Select FEEDER (A). The FEEDER SETUP page appears.
3. Select MAXIMUM WORK HEIGHT field (B).

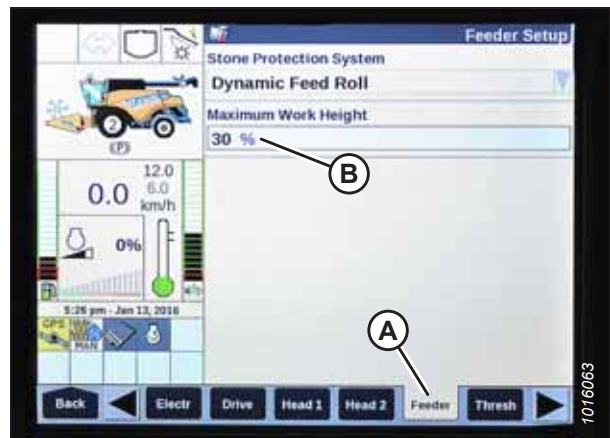

Figure 8.468: New Holland Combine Display

4. Set MAXIMUM WORK HEIGHT to the desired value.
5. Select SET and then press ENTER.



Figure 8.469: New Holland Combine Display

SETTING UP AUTO HEADER HEIGHT CONTROL SYSTEM

Configuring Reel Fore-Aft, Header Tilt, and Header Type – New Holland CR Series and CH

The reel fore-aft, header tilt, and header type settings for the auto header height control (AHHC) system can be changed by accessing the HEAD menus.

NOTE:

CR models: This procedure applies only to 2016 New Holland CR models 6.90, 7.90, 8.90, and 9.90.

NOTE:

Changes may have been made to the combine controls or the display since this document was published. For the most up-to-date information, refer to the combine operator's manual.

NOTE:

Some New Holland combines will not allow you to change the header settings from the main menu. This is now a dealer setting. If you cannot change the header settings from the main menu, contact your Dealer.

 **DANGER**

Ensure that all bystanders have cleared the area.

1. Turn the ignition key to the RUN position.
2. On the HEAD 1 page, change CUTTING TYPE (A) from FLEX to PLATFORM.



Figure 8.470: New Holland Combine Display

3. On the HEAD 2 page, change HEADER SUB TYPE (A) from DEFAULT to 80/90.



Figure 8.471: New Holland Combine Display

SETTING UP AUTO HEADER HEIGHT CONTROL SYSTEM

There are now two different buttons for the ON GROUND presets. The toggle switch that was present on previous models is now configured as shown at right. MacDon headers only require first two buttons (A) and (B). Third button down (C) is not configured.



Figure 8.472: New Holland Combine Controls

Reel Reverse Function – New Holland CR Series and CH

You can allow the reel to reverse with the feeder house on New Holland CR Series and CH combines.

DANGER

Ensure that all bystanders have cleared the area.

NOTE:

Changes may have been made to the combine controls or the display since this document was published. For the most up-to-date information, refer to the combine operator's manual.

1. Select TOOLBOX (A) on the MAIN page.



Figure 8.473: New Holland Combine Display

SETTING UP AUTO HEADER HEIGHT CONTROL SYSTEM

2. Select HEAD 1 tab (A).

NOTE:

To locate the HEAD 1 tab, you may need to use side arrows (B).

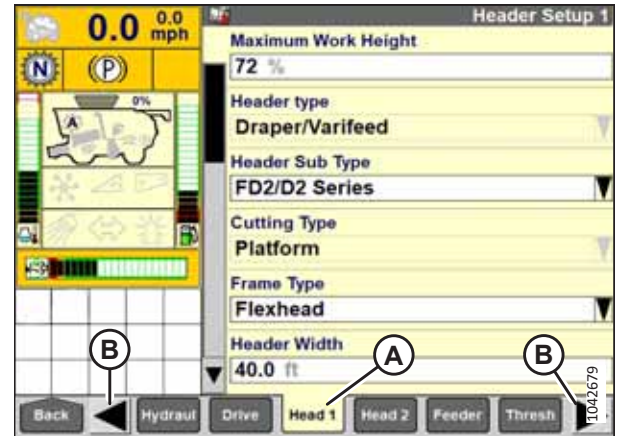

Figure 8.474: New Holland Combine Display

3. Locate the HEADER SUB TYPE field.
4. Select the following value from the HEADER SUB TYPE window:
 - If software version 36.4.X.X or later is installed, select FD2/D2 SERIES (A).

NOTE:

Selecting FD2/D2 SERIES will optimize AHHC performance on D2 Series Draper Headers.

- If software version prior to 36.4.X.X is installed, select 80/90.

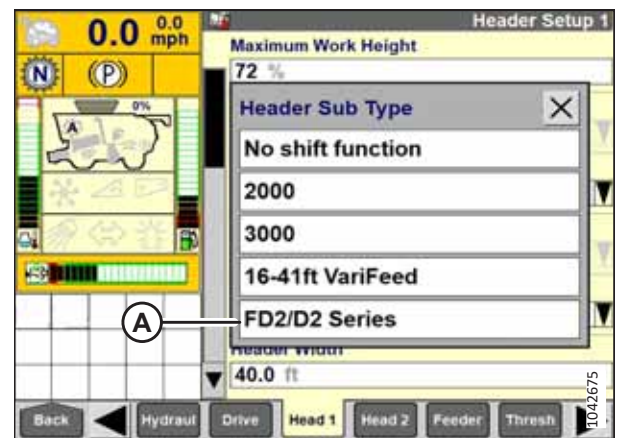

Figure 8.475: New Holland Combine Display

5. Return to the HEAD 1 page and choose RIGID from FRAME TYPE drop-down menu (A).



Figure 8.476: New Holland Combine Display

SETTING UP AUTO HEADER HEIGHT CONTROL SYSTEM

6. Select HEAD 2 tab (A).
7. In HEADER SENSORS field (B), select ENABLE.
8. In HEADER PRESSURE FLOAT field (C), select NO.
9. In HEIGHT/TILT RESPONSE field (D), select FAST.

NOTE:

AUTO HEADER LIFT field (E) can be set to the user's preference.

10. Press down arrow (F) to go to the next page.

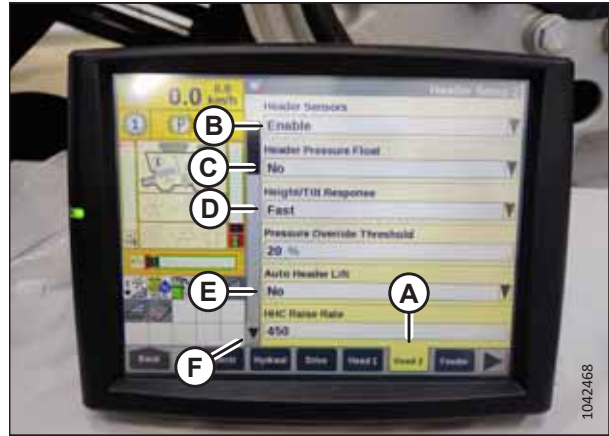

Figure 8.477: New Holland Combine Display

11. In HYDRAULIC REEL field (A), select YES.
12. In HYDRAULIC REEL REVERSE field (B), select YES.



Figure 8.478: New Holland Combine Display

13. In OVERLAP MODE field (A), select MANUAL.
14. In WORK WIDTH RESET field (B), select MANUAL.

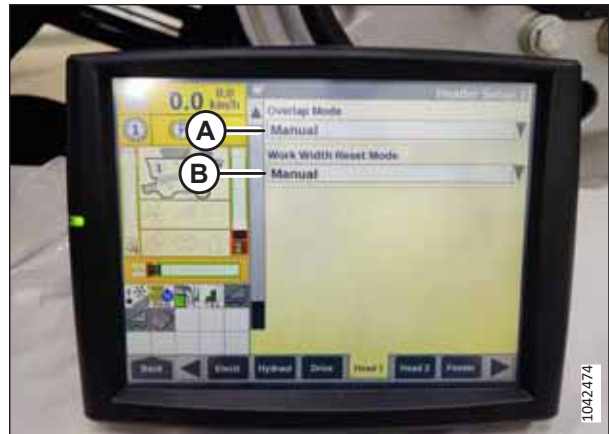

Figure 8.479: New Holland Combine Display

8.1.21 Rostselmash Combines – RSM 161, T500, and TORUM 785

Instructions on using the header’s auto header height control (AHHC) system with Rostselmash combines are provided.

Calibrating Auto Header Height Control – Rostselmash RSM 161, T500, and TORUM 785

The auto header height control (AHHC) sensor output must be calibrated for each combine, or the AHHC feature will not work properly. The AHHC feature on Rostselmash combines can be calibrated using the automatic calibration procedure.

DANGER

Ensure that all bystanders have cleared the area.

NOTE:

Changes may have been made to the combine controls or the display since this document was published. For the most up-to-date information, refer to the combine operator’s manual.

1. Ensure that the center-link is set to **D**.

NOTE:

When calibration is complete, adjust the center-link back to the desired header angle. For instructions, refer to the header operator’s manual.

2. Set the engine throttle to operating speed.
3. Park the combine on a level surface.
4. Allow the engine to reach normal operating temperature.
5. Lower the header to the ground.
6. Ensure that needle (A) on the float module’s float indicator is pointing to 4 (B), as shown.

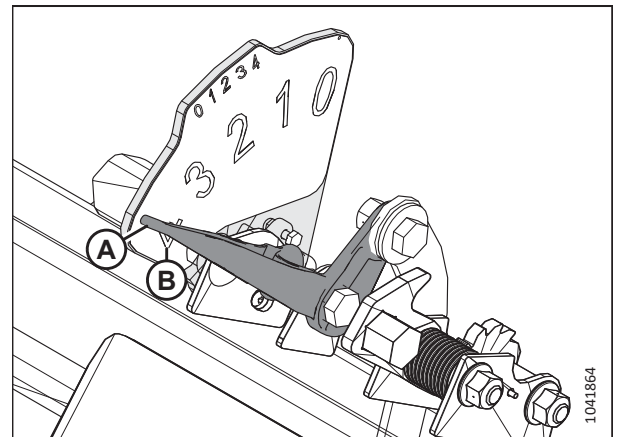

Figure 8.480: Float Indicator

SETTING UP AUTO HEADER HEIGHT CONTROL SYSTEM

7. Select WRENCH icon (A). SETTINGS window (B) appears.



Figure 8.481: Settings Menu

8. Select CALIBRATIONS icon (A). The CALIBRATION SETTINGS menu appears.



Figure 8.482: Settings Menu – Calibration Button

9. Select GCFS (A).

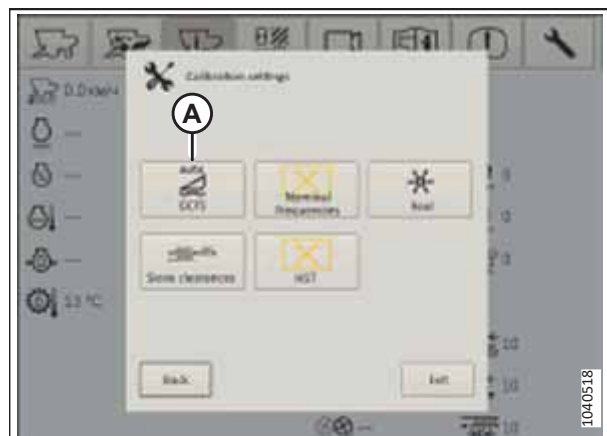

Figure 8.483: Calibration Settings Menu

SETTING UP AUTO HEADER HEIGHT CONTROL SYSTEM

10. Press START CALIBRATION (A). The header will rise to its maximum height, then fall to the lowest possible position.

NOTE:

If the system reports sensor voltages that are out of the acceptable range (0.7–4.3 V), the calibration will fail. The voltage range should be measured at the sensors. For instructions on inspecting the voltage range of the header height sensors, refer to [8.1.3 Manually Checking Voltage Limits](#), page 269.

11. Adjust the center-link to the desired setting. For instructions, refer to the header operator’s manual.

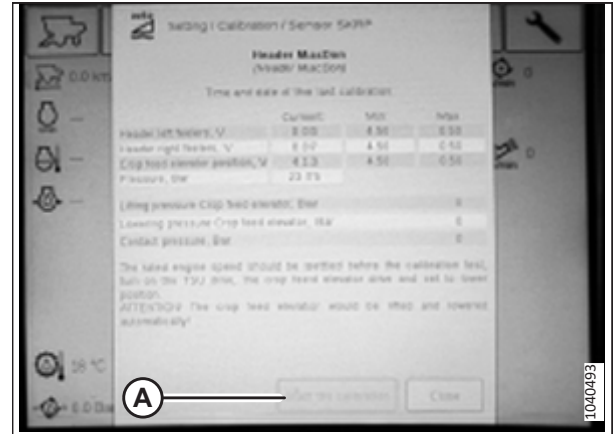

Figure 8.484: Calibration Screen

Engaging Auto Header Height Control – Rostselmash RSM 161, T500, and TORUM 785

Once the auto header height control (AHHC) system has been configured on the combine, the AHHC system will need to be activated in the combine’s computer.

NOTE:

Changes may have been made to the combine controls or the display since this document was published. For the most up-to-date information, refer to the combine operator’s manual.

⚠ DANGER

Ensure that all bystanders have cleared the area.

1. Select WRENCH icon (A). SETTINGS window (B) will appear.
2. Select GCFS (C). The GCFS SETTINGS page will appear.

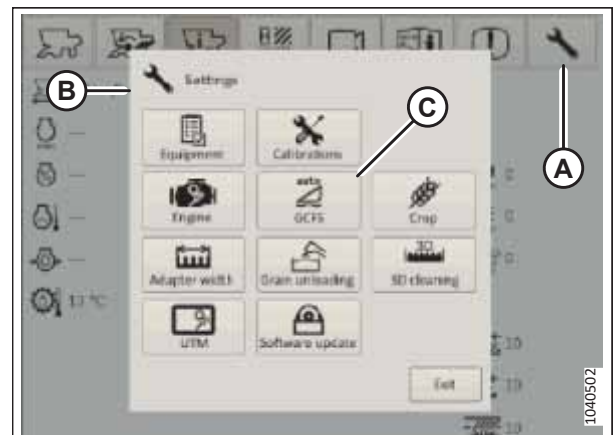

Figure 8.485: Settings Menu

SETTING UP AUTO HEADER HEIGHT CONTROL SYSTEM

3. Ensure that MODE 1 (A) and MODE 2 (B) are set to CUTTING HEIGHT MAINTAINING MODE.
4. Select OK button (C) to confirm the changes.

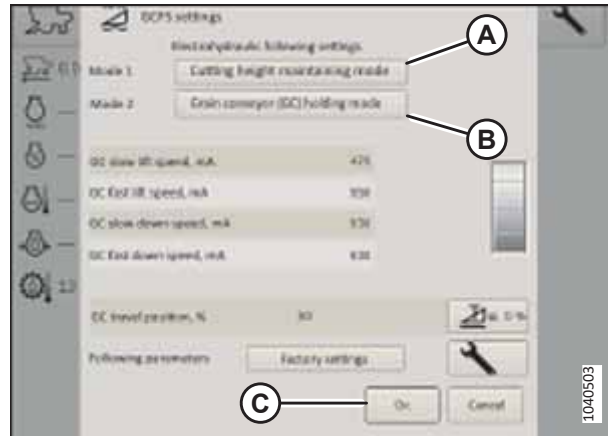

Figure 8.486: Settings Menu

Calibrating Reel Speed – Rostselmash RSM 161, T500, and TORUM 785

The reel speed will need to be calibrated before the automatic reel speed feature of the auto header height control (AHC) system on Rostselmash combines can be used.

DANGER

Ensure that all bystanders have cleared the area.

NOTE:

Changes may have been made to the combine controls or the display since this document was published. For the most up-to-date information, refer to the combine operator's manual.

1. Start the engine.
2. Park the combine on a level surface.
3. Allow the engine to reach normal operating temperature.
4. Select WRENCH icon (A). SETTINGS window (B) appears.



Figure 8.487: Settings Menu

SETTING UP AUTO HEADER HEIGHT CONTROL SYSTEM

5. Select CALIBRATIONS icon (A). The CALIBRATION SETTINGS window appears.



Figure 8.488: Settings Menu – Calibration Button

6. Select REEL icon (A). The REEL CALIBRATION page appears.



Figure 8.489: Calibration Settings Menu

7. Select START CALIBRATION (A). The display will emit a beep to indicate that the procedure has begun. The reel will begin rotating and will stop when calibration is complete. This procedure may take several minutes to complete.

8. Select OK button (B).

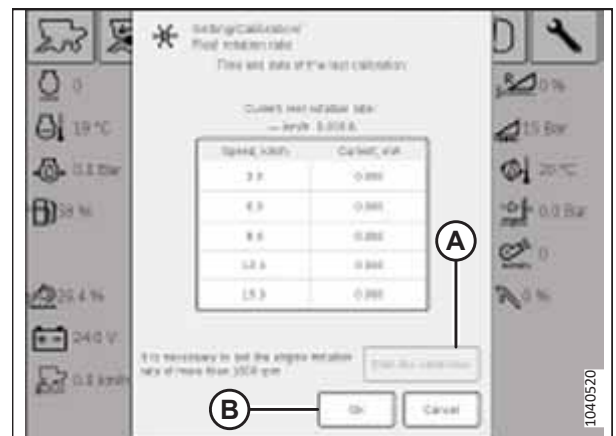

Figure 8.490: Reel Calibration Page

SETTING UP AUTO HEADER HEIGHT CONTROL SYSTEM

Operating Header – Rostselmash RSM 161, T500, and TORUM 785

Once the auto header height control (AHHC) system has been calibrated, the header settings can be optimized using the controls in the combine's cab.

DANGER

Ensure that all bystanders have cleared the area.

NOTE:

Changes may have been made to the combine controls or the display since this document was published. For the most up-to-date information, refer to the combine operator's manual.

1. Engage the combine's feeder house. For instructions, refer to the combine operator's manual.
2. Engage the header. For instructions, refer to the combine operator's manual.
3. On the combine control handle, use raise/lower header button (A) to move the header to the desired height.



Figure 8.491: Combine Control Handle

NOTE:

Preset height settings should be between 10 and 50% ground pressure, as indicated on GROUND PRESSURE BAR (A).



Figure 8.492: Combine Operating Page

SETTING UP AUTO HEADER HEIGHT CONTROL SYSTEM

4. Press and hold button (B) for 3 seconds to save the height preset. Press and release button (B) again to cause the header to move to the preset height.
5. If you wish to set another preset on button (C):
 - a. Use raise/lower header button (A) to move the header to another desired height.
 - b. Press and hold button (C) for 3 seconds to save the second height preset. Press and release button (C) again to move the header to the second preset height.

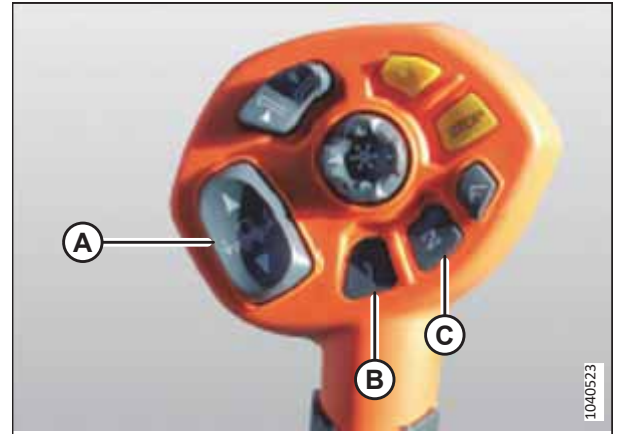

Figure 8.493: Combine Control Handle

Chapter 9: Running up Header

Before delivering the header to the customer, observe its performance to ensure that all of its features are functional.

DANGER

To prevent bodily injury or death from the unexpected start-up or fall of a raised machine, always stop the engine and remove the key before leaving the operator's seat, and always engage the safety props before going under the machine for any reason.

DANGER

Ensure that all bystanders have cleared the area.

1. Raise the header fully.
2. Shut down the engine, and remove the key from the ignition.
3. Engage the header safety props. For instructions, refer to the combine operator's manual.
4. Lower the plastic pan under the float module. Check for debris that may have fallen under the float module draper.
5. Rotate latches (A) to unlock handles (B).
6. Hold pan (C) and rotate handles (B) to release the pan. Lower the pan to expose the draper.

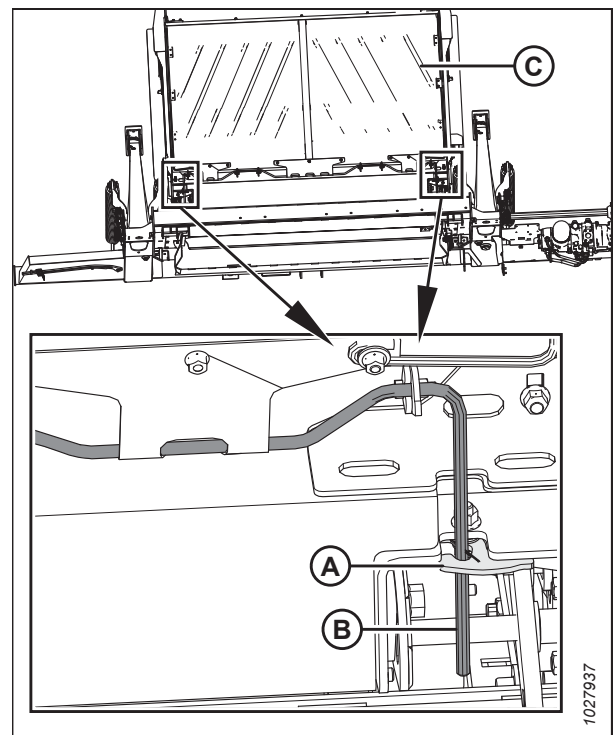

Figure 9.1: Float Module Plastic Pan

RUNNING UP HEADER

- Remove any debris from pan (A) and the draper.

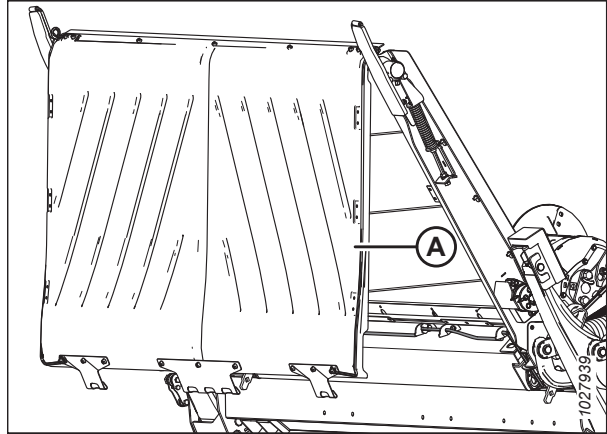

Figure 9.2: Float Module Plastic Pan

- Raise the pan. Rotate handle (A) so that the rod engages clips (B) on the pan.

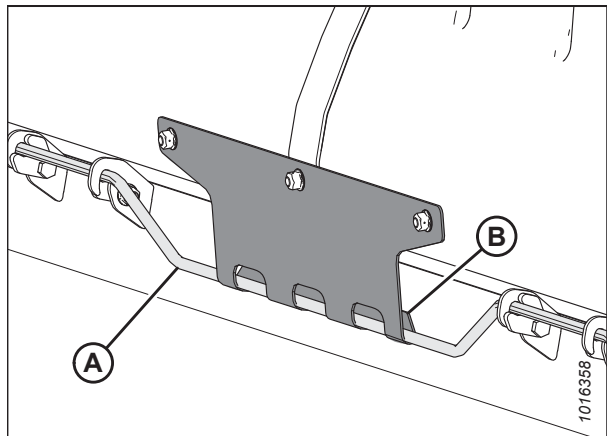

Figure 9.3: Clips Engaged

- Push handle (A) into the slot and secure it with latches (B).
- Ensure that the feeder house variable speed is set to maximum.
- Engage the header with the combine running at low idle.
- Run the machine for two minutes while watching and listening from the operator's seat for binding or interfering parts.

NOTE:

The reel and the side drapers will not operate until the hydraulic oil flow fills the lines.

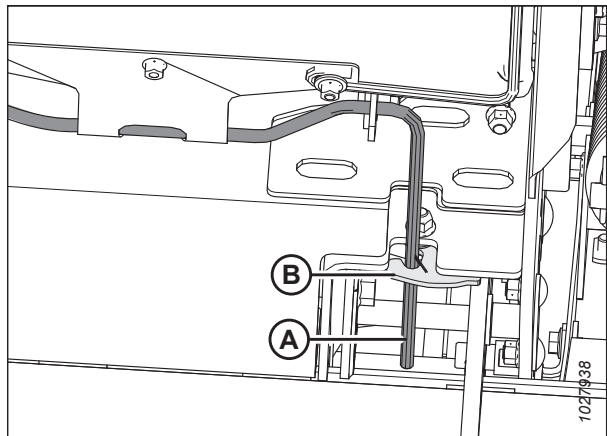

Figure 9.4: Latches Secured

- Adjust the reel speed to maximum. For instructions, refer to the combine operator's manual.
- Adjust the draper speed to maximum. For instructions, refer to [9.1 Adjusting Side Draper Speed, page 501](#).
- Run the machine at operating speed for 15 minutes. Listen for any unusual sounds or abnormal vibration.

RUNNING UP HEADER

16. Check the knife speed. For instructions, refer to [9.2 Checking and Adjusting Knife Speed – Dynamatic Integrated Pump \(MD #337774\)](#), page 503.
17. Perform the run-up checks listed in (the yellow sheet attached to this instruction) to ensure that the machine is field-ready.
18. Check the speed of flywheel (A) using a tachometer.
19. Compare the actual flywheel speed with the values in [Table 9.1, page 501](#).

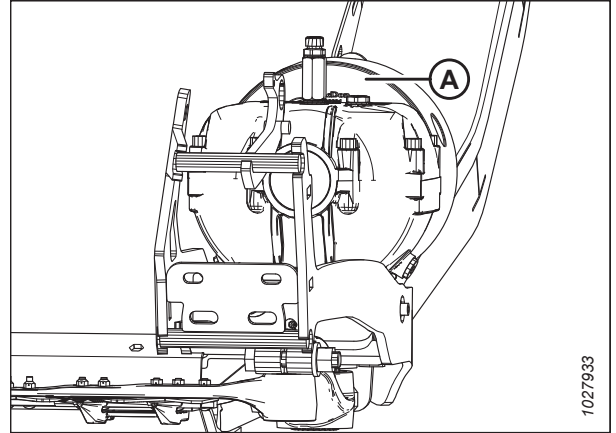

Figure 9.5: Knife Drive Box

Table 9.1 D2 Series Knife Speed

Header	Recommended Knife Drive Speed Range (rpm)	
	Single-Knife Drive	Double-Knife Drive
D225	600–700	—
D230	600–750	—
D235	600–700	600–750

9.1 Adjusting Side Draper Speed

The side drapers carry the cut crop to the float module feed draper, which then feeds the crop into the combine. You can adjust the speed of the side drapers for various crops and crop conditions.

Side drapers (A) are driven by hydraulic motors and by a pump that is powered by the combine feeder house drive through a gearbox on the float module. From inside the cab, you can adjust the side draper speed on the side draper speed control, which regulates the flow to the draper hydraulic motors.

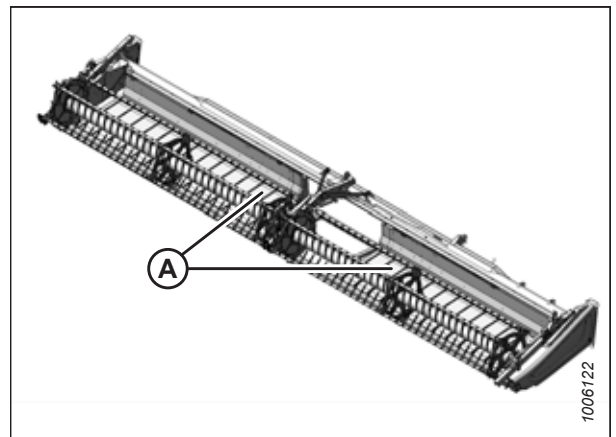

Figure 9.6: Side Drapers

RUNNING UP HEADER

Combines with integrated controls

Use the integrated draper controls to set the draper speed. For instructions, refer to the combine operator's manual. For header settings, refer to the header operator's manual.

Combines with MacDon In-Cab Side Draper Speed Control

Rotate knob (A) to set the draper speed. For header settings, refer to the header operator's manual.

NOTE:

Switch (B) in Figure 9.7, [page 502](#) allows the operator to switch between the header tilt and reel fore-aft controls..

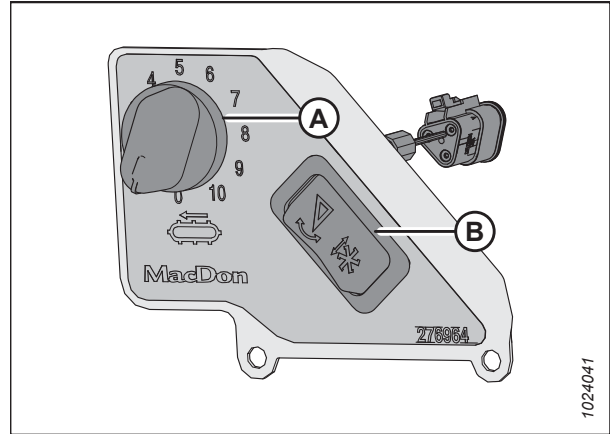

Figure 9.7: In-Cab Side Draper Speed Control

NOTE:

For Case IH and New Holland combines, the switch to activate the header tilt and reel fore-aft controls is located behind the ground speed lever (GSL).

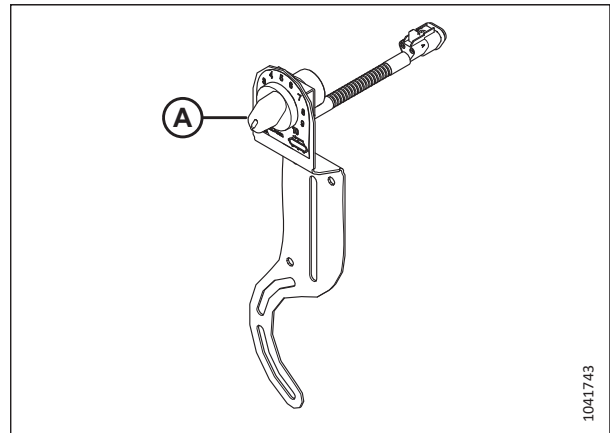

Figure 9.8: Case IH and New Holland In-Cab Side Draper Speed Control

9.2 Checking and Adjusting Knife Speed – Dynamatic Integrated Pump (MD #337774)

If the knife drive is not operating within the recommended speed range, the knife speed will need to be adjusted.

DANGER

To prevent bodily injury or death from the unexpected start-up of the machine, always stop the engine and remove the key from the ignition before making adjustments to the machine.

DANGER

Ensure that all bystanders have cleared the area.

1. Shut down the engine, and remove the key from the ignition.
2. Open the endshield. For instructions, refer to [10.4.1 Opening Header Endshields, page 522](#).
3. Start the engine.
4. Engage the header drive, and run the feeder house at the maximum speed as shown in [Table 9.2, page 503](#).

IMPORTANT:

Before checking the knife speed, make sure the feeder house is set to maximum speed. This will prevent the knife from overspeeding when making further adjustments.

5. Allow the hydraulic oil to warm up.

Table 9.2 Feeder House Speed

Combine Make	Feeder House Speed (rpm)
Case IH	580
Challenger®	625
CLAAS 500/600/700	Display Speed: 420 Actual Shaft Speed: 750
CLAAS 5000/ 6000/7000/8000	750
Gleaner®	625
IDEAL™	620
John Deere ²⁸	490
Massey Ferguson®	625
New Holland	580
Rostselmash	580

28. Some John Deere combines have a fixed feeder house speed of 520 rpm. For hydraulic testing purposes, this difference is not significant.

RUNNING UP HEADER

- Measure and record the rpm of flywheel (A) with a hand-held photo tachometer.

NOTE:

One revolution (rpm) is equivalent to two knife strokes (spm) (1 rpm = 2 spm).

- Shut down the engine, and remove the key from the ignition.

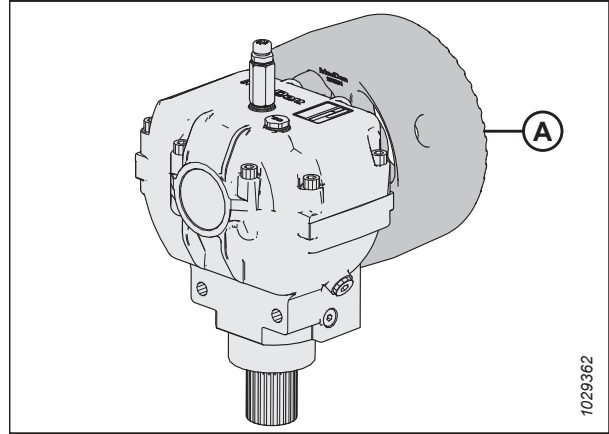

Figure 9.9: Flywheel

- Compare the flywheel rpm measurement with the rpm values in Table 9.3, page 504.

NOTE:

The knife drive speed on all header model is factory-set to 650 rpm.

Table 9.3 D2 Series Knife Speed

Header	Recommended Knife Drive Speed Range (rpm)	
	Single-Knife Drive	Double-Knife Drive
D225	600–700	—
D230	600–750	—
D235	600–700	600–750

- Loosen bolt (A).
- Turn knife drive adjuster (B) clockwise to increase, or counterclockwise to decrease, the knife speed.
- If the desired flywheel rpm is achieved, re-tighten bolt (A), and proceed to Step 17, page 505.
 - If the desired flywheel rpm is not achieved, proceed to the next step to make coarser adjustments to the pump flow.

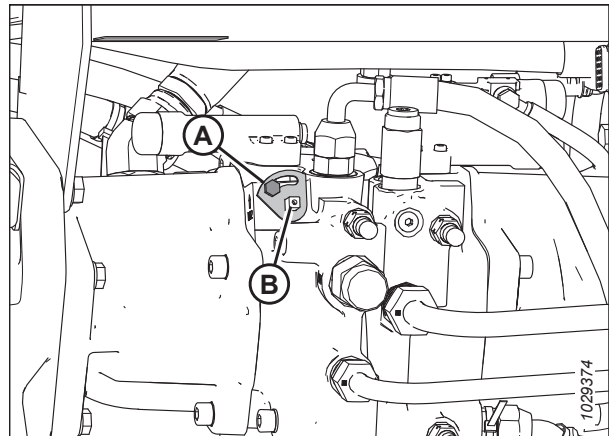

Figure 9.10: Integrated Pump

RUNNING UP HEADER

12. Remove bolt (A).
13. Remove adjuster plate (B).

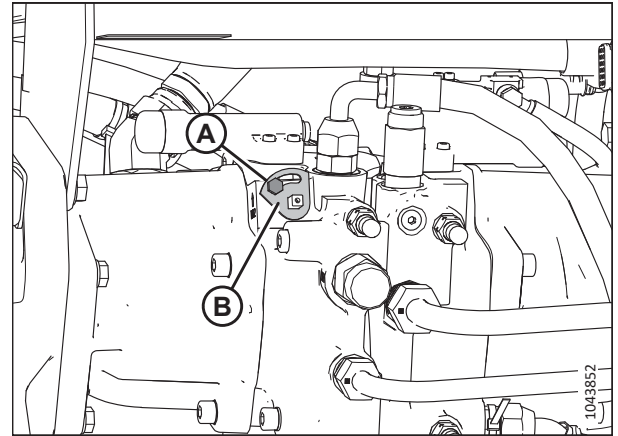

Figure 9.11: Integrated Pump

14. Turn knife drive adjuster (A) clockwise to increase, or counterclockwise to decrease, the knife speed.
15. If the desired flywheel rpm is achieved, reinstall adjuster plate (B) and bolt (A). Retighten bolt (A). Proceed to Step [17, page 505](#).
16. If the desired rpm cannot be achieved after adjusting the knife drive pump, the knife drive motor or pump will need to be tested. For instructions on testing the motor or pump, refer to the header's technical manual.
17. Close the endshield. For instructions, refer to [10.4.2 Closing Header Endshields, page 523](#).

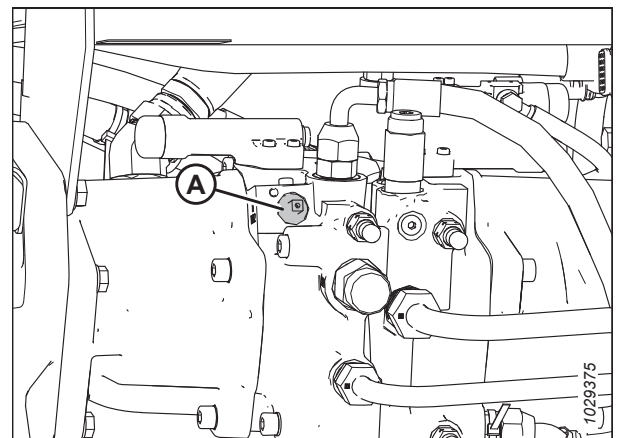

Figure 9.12: Integrated Pump

9.3 Adjusting Side Draper Tracking

If the side drapers rub the header frame during operation, the draper tracking may need to be adjusted.

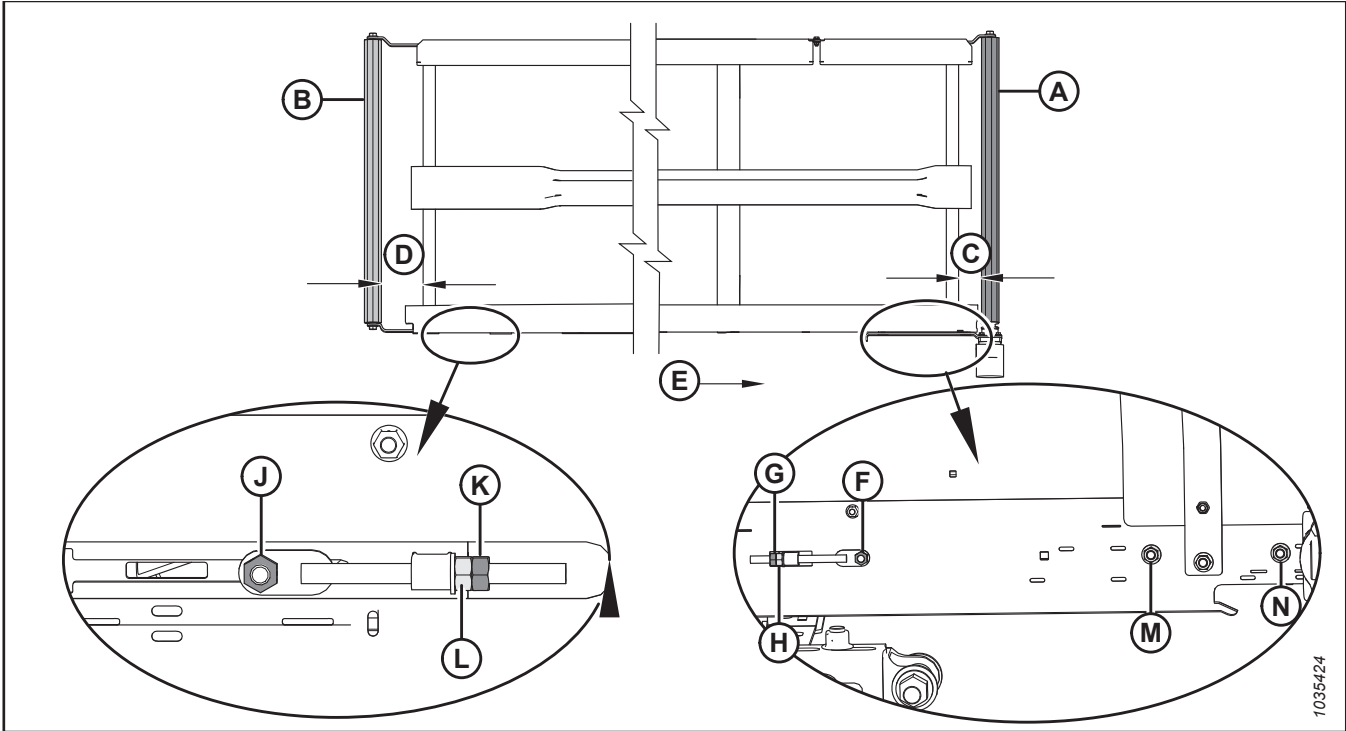

Figure 9.13: Draper Tracking Adjustments – Left Draper

- A - Drive Roller
- B - Idler Roller
- C - Drive Roller Adjust
- D - Idler Roller Adjust
- E - Draper Direction
- F - Nut on Drive Roller Side
- G - Jam Nut for Drive Roller
- H - Adjuster Nut for Drive Roller
- J - Nut on Idler Roller Side
- K - Jam Nut for Idler Roller
- L - Adjuster Nut for Idler Roller
- M - Nut on Drive Roller Side
- N - Nut on Drive Roller Side

1. To determine which roller requires adjustment and which adjustments are necessary, refer to the following table:

Table 9.4 Draper Tracking

If tracking towards	Location	Adjustment	Method
Backsheet	Drive roller	Increase C	Tighten adjuster nut (H)
Cutterbar	Drive roller	Decrease C	Loosen adjuster nut (H)
Backsheet	Idler roller	Increase D	Tighten adjuster nut (L)
Cutterbar	Idler roller	Decrease D	Loosen adjuster nut (L)

RUNNING UP HEADER

2. Adjust drive roller (A) to change **C** (refer to Table 9.4, page 506 and Figure 9.13, page 506) as follows:
 - a. Loosen nuts (F), (M), and (N), and jam nut (G).
 - b. Turn adjuster nut (H).
 - c. Tighten nuts (F), (M), and (N), and jam nut (G).
3. Adjust idler roller (B) to change **D** (refer to Table 9.4, page 506 and Figure 9.13, page 506) as follows:
 - a. Loosen nut (J) and jam nut (K).
 - b. Turn adjuster nut (L).

NOTE:

If the draper does not track at the idler roller end after the idler roller has been adjusted, the drive roller is likely not in line with the deck. Adjust the drive roller, and then readjust the idler roller.

- c. Tighten nut (J) and jam nut (K).

9.4 Post Run-Up Adjustments

After running up the header up for the first time, a few adjustments will need to be made.

Perform the post run-up checks listed in the Predelivery Checklist (the yellow sheet attached to this instruction - *Predelivery Checklist, page 541*) to ensure the machine is field-ready.

9.4.1 Checking Knife Position

The clearance between the knifehead and drive arm will need to be inspected.

DANGER

To prevent injury or death from the unexpected start-up of the machine, always stop the engine and remove the key from the ignition before leaving the operator's seat for any reason.

1. Shut down the engine, and remove the key from the ignition.
2. Check the guards for signs of heating during run-up due to insufficient clearance between the guard and the knife.
3. Check clearance (C) between knifehead (A) and drive arm (B). There should be 0.2–1.2 mm (0.007–0.047 in.) of clearance.

IMPORTANT:

Overgreasing the knife can cause it to bend and make contact with the guards closest to the knifehead. Check the knife for signs of excessive heating on first few guards after greasing. If necessary, relieve some of the pressure by pressing the check-ball in the grease fitting, or by removing the grease fitting.

4. If the drive arm needs adjustment, refer to the header's technical manual for instructions.

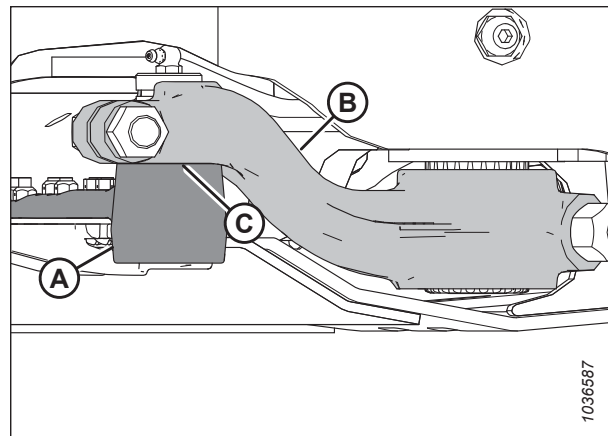

Figure 9.14: Knifehead and Drive Arm

9.4.2 Checking and Adjusting Feed Draper Tension

In order for the draper to operate correctly, it must be tensioned properly. Inspect the tension on the draper and if necessary, adjust it.

DANGER

To prevent bodily injury or death from the unexpected start-up or fall of a raised machine, always stop the engine and remove the key before leaving the operator's seat, and always engage the safety props before going under the machine for any reason.

DANGER

Ensure that all bystanders have cleared the area.

NOTE:

The illustrations in this procedure show the left side of the header; the right side of the header is similar.

1. Start the engine.
2. Raise the header fully.
3. Shut down the engine, and remove the key from the ignition.
4. Engage the header safety props. For instructions, refer to the combine operator's manual.

Checking the feed draper tension

5. Ensure that the draper guide (the rubber track on the underside of the draper) is properly engaged in the groove on the drive roller and that the idler roller is between the guides.
6. Check the position of spring retainer disc (A). If the feed draper tracks properly and the spring retainers on both sides of the draper are correctly positioned, then no adjustment is necessary.

NOTE:

The starting position of spring retainer disc (A) is centered within the U shape on indicator (B); however, the position of disc (A) will vary after the draper tracking is adjusted.

7. If adjustment is necessary, proceed to Step 8, page 510.

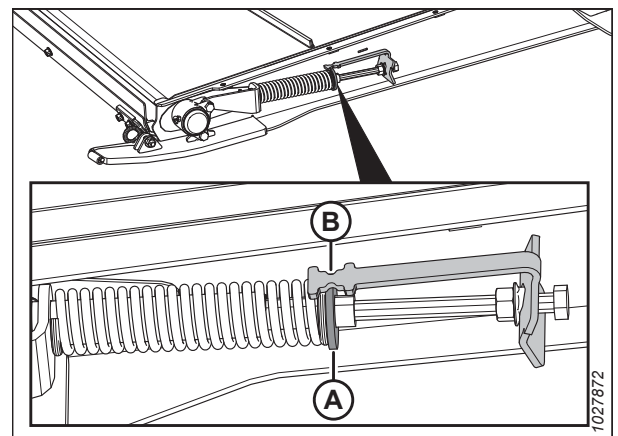

Figure 9.15: Feed Draper Tensioner

Adjusting the feed draper tension

8. Adjust the draper tension by loosening jam nut (A) and turning bolt (B) clockwise to increase the tension on the draper (or counterclockwise to decrease the tension on the draper). Retainer disc (C) should be in the middle of indicator (D).

IMPORTANT:

For small tension adjustments, only one side of the draper needs to be adjusted. To prevent uneven draper tracking for larger tension adjustments, both sides of the draper will need to be adjusted.

9. If the draper is not tracking properly, adjust retainer disc (C) so that it is **NOT** in the middle of indicator (D), but within the following range:
 - When loosened to 3 mm (1/8 in.), retainer disc (C) will move toward the front of the deck from center of indicator (D).
 - When tightened to 6 mm (1/4 in.), retainer disc (C) will move toward the back of the deck from the center of indicator (D).
10. Tighten jam nut (A). Ensure that flange nut (E) is tight against the indicator bracket.

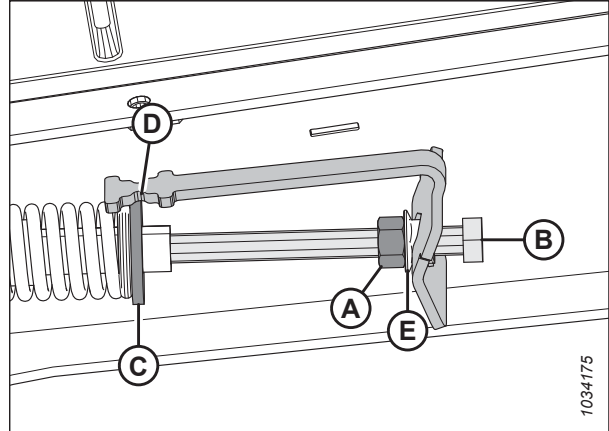

Figure 9.16: Feed Draper Tensioner – Left Side

Chapter 10: Reference

Refer to the procedures and information in this chapter as needed.

10.1 Changing Float Spring Configuration and Installation Location

The header's float spring configuration and location is determined by the weight of the header. If the weight of the header has changed (for example, due to the addition of optional equipment), the float spring configuration may need to be changed. To determine the appropriate float spring configuration, the weight of the header and optional equipment must be calculated.

NOTE:

For D2 Series Headers shipped in North America (D225, D230, and D235), this information is intended for reference only. Changing the float spring configuration and installation location should not be necessary for those models.

 **DANGER**

To prevent injury or death from the unexpected start-up of the machine, always stop the engine and remove the key from the ignition before leaving the operator's seat for any reason.

Determining header weight and spring configuration

1. Refer to Table 10.1, page 511 to determine the total header weight according to the following formula:

(A) Base Header Weight (no options)	+	(B) Dividers Weight (if installed)	+	(C) and (D) Option Weight (sum of all options)	=	Total Header Weight
--	---	---	---	---	---	----------------------------

Table 10.1 Header Component Weights

Category	Header Model	Knife Configuration	Reel Configuration	Weight
(A) Base header weight – select one	D225	Single	Single	1,850 kg (4,079 lb.)
	D230	Single	Double	2,300 kg (5,070 lb.)
	D235	Single	Double	2,500 kg (5,512 lb.)
	D241	Double	Double	2,800 kg (6,173 lb.)
	D245	Double	Double	2,950 kg (6,504 lb.)
(B) Dividers – select up to one option	Divider Option Installed			20 kg (44 lb.)
	Rice divider rods			
	Vertical knives			185 kg (408 lb.) ²⁹
(C) Upper cross auger (UCA) – select one size option ³⁰	UCA Option Installed			142 kg (312 lb.)
	9.1 m (30 ft.) two-piece auger			
	10.7 m (35 ft.) two-piece			
	12.5 m (41 ft.) two-piece			
	13.7 m (45 ft.) three-piece			

29. Weight includes B7029 and B7410 (hydraulic package for D245).

30. Add 24.5 kg (54 lb.) for hydraulic plumbing, if this was installed separately.

REFERENCE

Table 10.1 Header Component Weights (continued)

	Option Installed	
(D) Other options – add any installed options	Transport wheels	379 kg (835 lb.)
	Stabilizer wheels	160 kg (353 lb.)

- Using the total header weight determined in the previous step, refer to Table 10.2, page 513 to determine which weight range the header is in and which float lever hole and float spring configuration are most appropriate for the header.

NOTE:

Generally, heavier headers will need the float springs placed in the front float lever hole and lighter headers will use the back hole. Some headers only have one possible float spring configuration and installation location.

Table 10.2 Float Spring Installation Location

Header Model	Knife Configuration	Reel Configuration	Lighter Weight Range	Float Lever Hole	Heavier Weight Range	Float Lever Hole	Float Spring Configuration See Table 10.3, page 513
D225	Single	Single	Use the back hole on the float lever for all configurations				1
D230	Single	Double	Use the back hole on the float lever for all configurations				1
D235	Single	Double	Use the back hole on the float lever for all configurations				1
D241	Double	Double	2,800–3100 kg (6173–6834 lb.)	Back	3101–3490 kg (6837–7694 lb.)	Front	2
D245	Double	Double	2,950–3,200 kg (6504–7055 lb.)	Back	3,201–3,710 kg (7057–8179 lb.)	Front	2

Table 10.3 Float Springs Configuration

Configuration "S" = Single Spring (MD #308878) "D" = Double Spring (MD #308879)	Float Springs Configuration			
	Outer Left Side	Inner Left Side	Inner Right Side	Outer Right Side
1 – SSSS	Single	Single	Single	Single
2 – SSSD	Single	Single	Single	Double

- Proceed as follows:
 - If the float springs need to be moved to a different float lever hole, proceed to the next step.
 - If a float spring needs to be changed, refer to the header technical manual.

Changing which float lever hole is used

4. Shut down the engine, and remove the key from the ignition.
5. Lock the header float by pulling the float lock handle into position (A) on the left side of the float module.

NOTE:

The float is unlocked when the handle is in position (B).

6. Repeat the previous step to set the float lock handle on the other side of the float module.

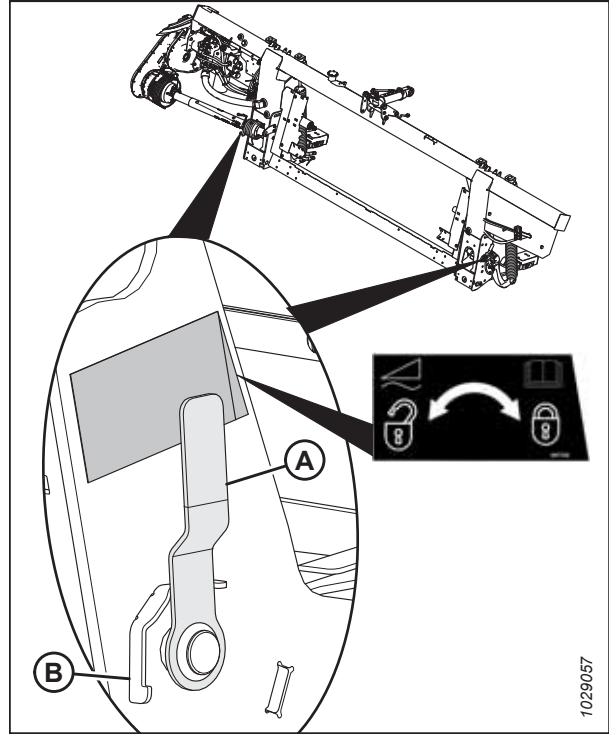

Figure 10.1: Header Float Lock in Locked Position

7. Access float spring adjustment bolts (A) by loosening bolts (C) and rotating spring locks (B) forward.
8. Loosen adjustment bolts (A) by making small adjustments to each bolt, one after the other, in identical increments, until the springs are loose.

NOTE:

The adjustment bolts will rise slightly above the washers when the springs are loose.

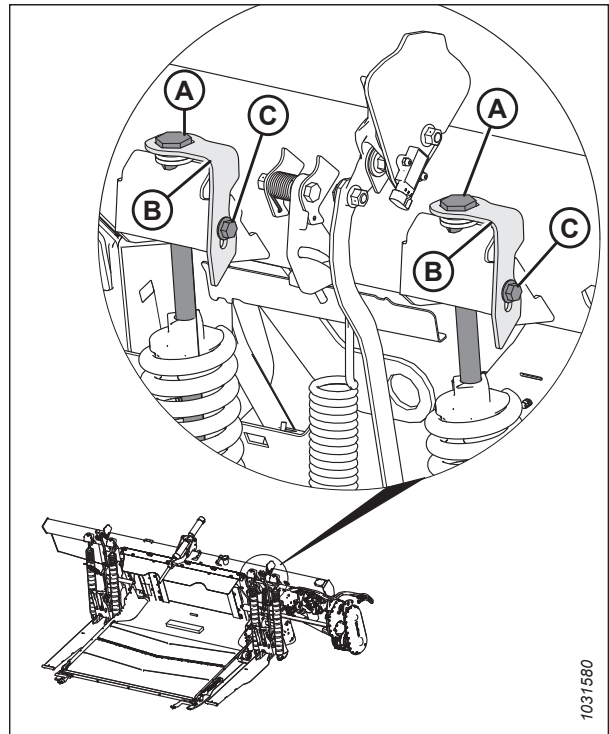

Figure 10.2: Left Float Adjustment

REFERENCE

9. Remove cotter pin (C) from pin (A).
10. Remove pin (A) and washers (B).

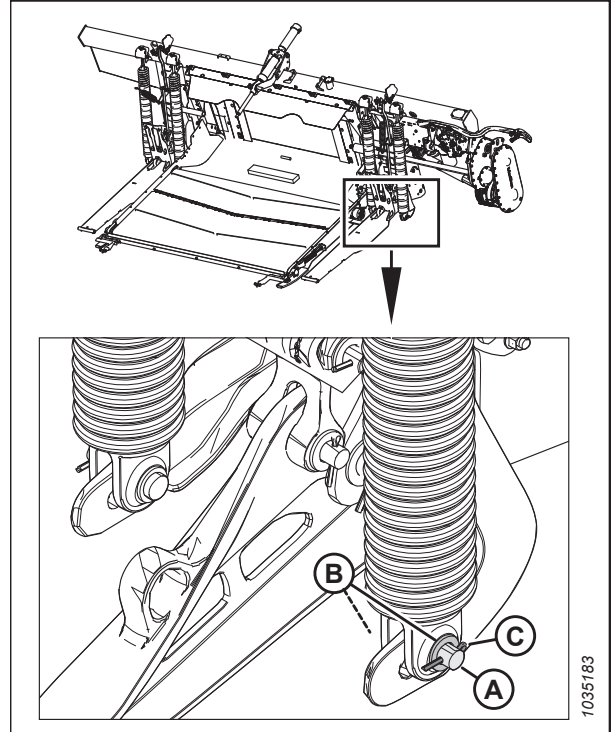

Figure 10.3: Left Float Spring Installed in Rear Float Lever Hole

11. Align the spring with front float lever hole (A) or back float lever hole (B) according to the specifications in Table 10.2, page 513.

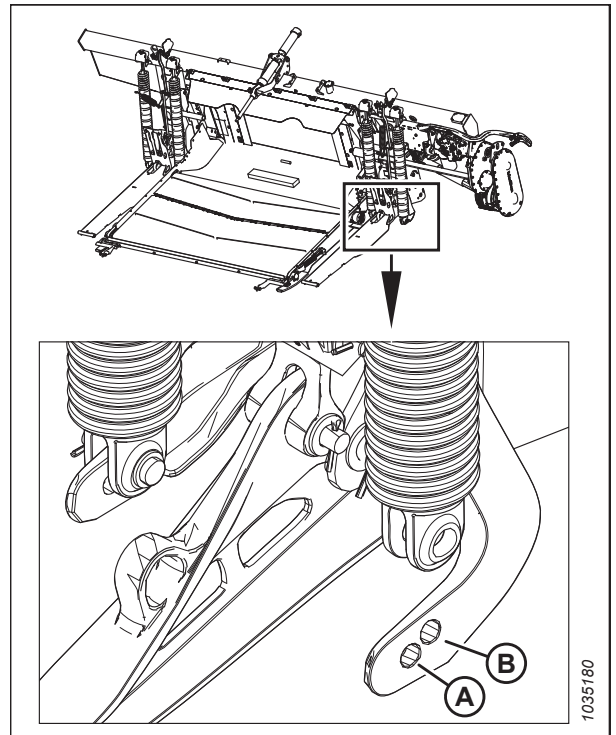

Figure 10.4: Left Float Spring Installed in Rear Float Lever Hole

REFERENCE

12. Install pin (A) and two washers (B) into the new hole.
13. Secure the pin with cotter pin (C).
14. Repeat Step [9, page 515](#) to Step [13, page 516](#) to configure other spring (D).

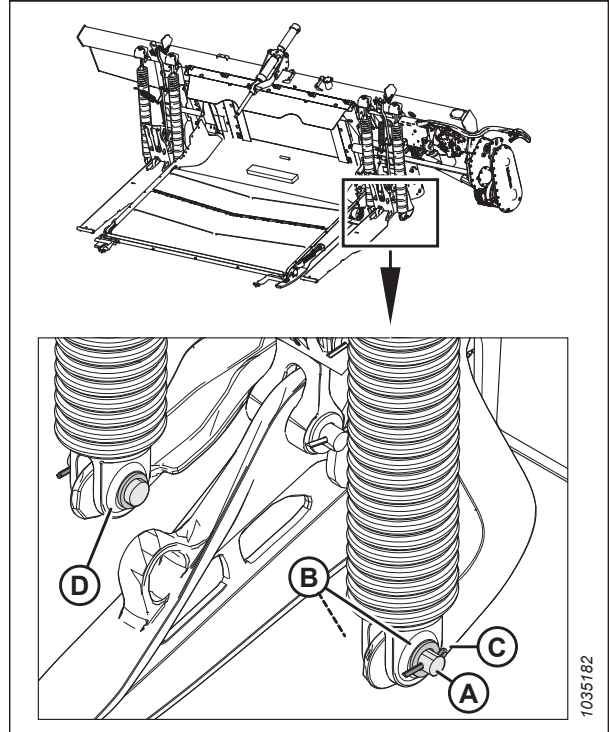

Figure 10.5: Left Float Spring – Installed in Rear Float Lever Hole

15. Retighten adjustment bolts (A) by making small adjustments to each bolt, one after the other, in identical increments, until the float springs are the same length.
16. Repeat Step [7, page 514](#) to Step [15, page 516](#) on the pair of float springs (B) on the opposite side of the float module.
17. Check and adjust the float. For instructions, refer to [6.10 Checking and Adjusting Header Float, page 229](#).

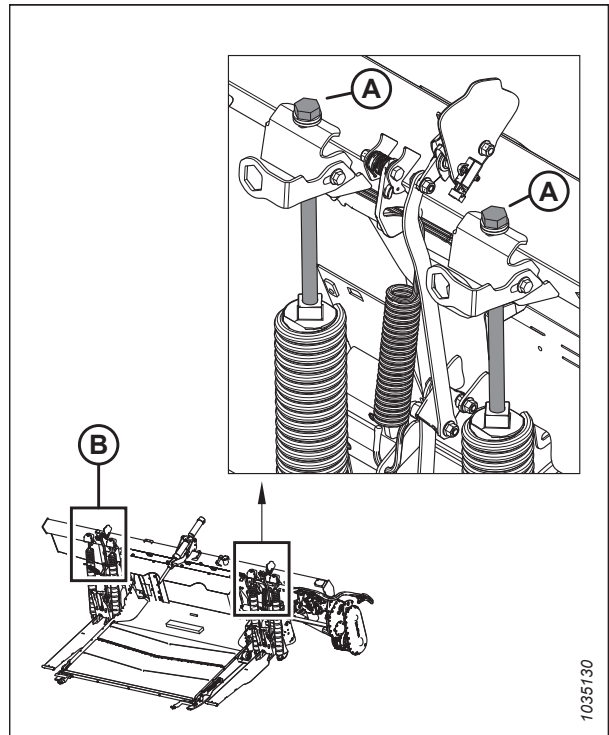

Figure 10.6: Float Adjustment – Left

10.2 Adjusting Side Draper Deck Height

A properly adjusted deck height will prevent material from entering into the side drapers and stalling them.

DANGER

To prevent bodily injury or death from the unexpected start-up or fall of a raised machine, always stop the engine, remove the key, and engage the safety props before going under the header for any reason.

1. Shut down the engine, and remove the key from the ignition.

NOTE:

Take measurements at deck supports (A) when the header is in the working position. Depending on the size of the header, there will be three, four, or five supports per deck.

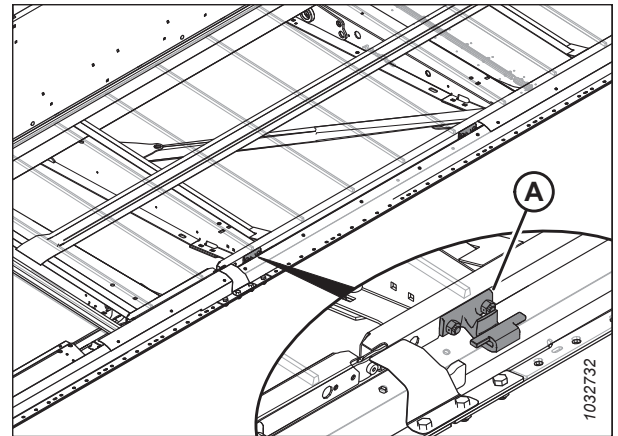

Figure 10.7: Draper Deck Supports

2. Ensure that clearance (A) between draper (B) and metal seal (C) is 1–4 mm (0.04–0.16 in.).
3. Relieve the tension on the draper. For instructions, refer to [6.12 Checking and Adjusting Side Draper Tension, page 238](#).

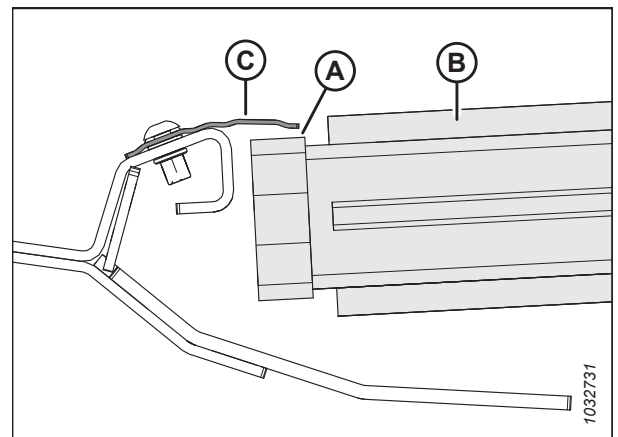

Figure 10.8: Draper Seal

REFERENCE

4. Lift front edge of draper (A) past cutterbar (B) to expose the deck support.
5. Measure and note the thickness of the draper belt.

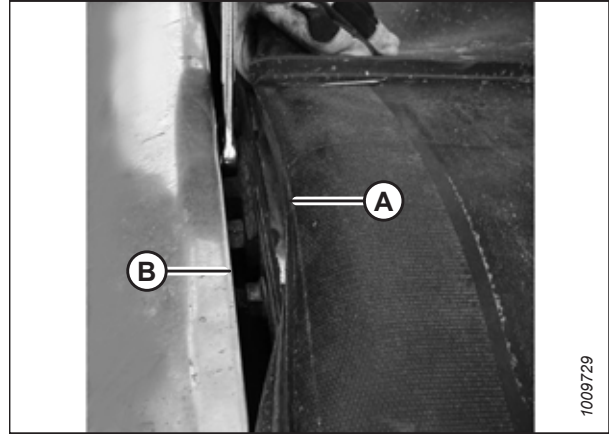

Figure 10.9: Deck Support

NOTE:

The draper has been removed in the image to show the deck.

6. Loosen two lock nuts (A) on deck support (B) by one half-turn **ONLY**.
7. Tap deck (C) with a hammer and a block of wood to lower the deck relative to the deck supports. Tap deck support (B) using a punch to raise the deck relative to the deck supports.

Table 10.4 Total Number of Deck Supports (B)

Model	Quantity
D225, D230	6
D235	8

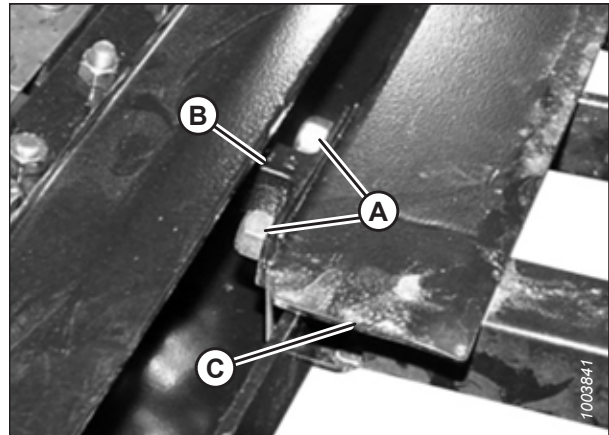

Figure 10.10: Deck Support

8. Use a feeler gauge that is the same thickness as the draper belt, plus 1 mm (0.04 in.). Slide the gauge along deck (A) under metal seal (C) to properly set the gap.
9. To create a seal, adjust deck (A) so that clearance (B) between metal seal (C) and the deck is the same thickness as the draper belt plus 1 mm (0.04 in.).

NOTE:

To check the clearance at a draper roller, begin measuring from the roller tube, **NOT** the deck.

10. Tighten deck support hardware (D).
11. Recheck gap (B) with the feeler gauge. For instructions, refer to Step 8, page 518.

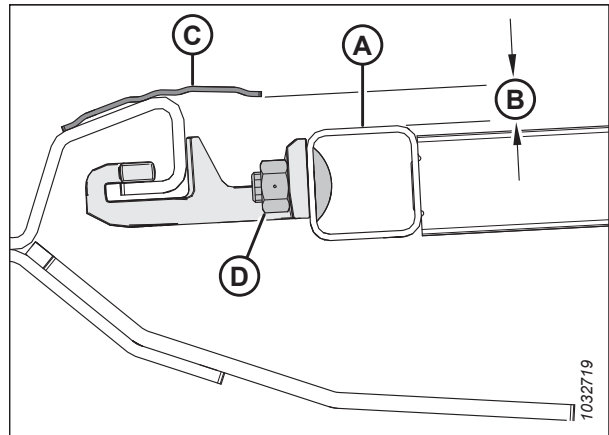

Figure 10.11: Deck Support

10.3 Reel Safety Props

The reel safety props are located on the reel arms. When engaged, the reel safety props prevent the reel from falling unexpectedly.

IMPORTANT:

To prevent damage to the reel support arms, do **NOT** transport the header with the reel safety props engaged.

10.3.1 Engaging Reel Safety Props

Engage the reel safety props anytime you need to work around a raised reel. When the reel safety props are engaged, they prevent the reel from unexpectedly lowering.

 **DANGER**

To prevent injury or death from the unexpected start-up of the machine, always stop the engine and remove the key from the ignition before leaving the operator's seat for any reason.

 **DANGER**

Ensure that all bystanders have cleared the area.

Outer reel arms

1. Raise the reel fully.
2. Shut down the engine, and remove the key from the ignition.
3. Lift up on safety prop (A) and push it forward to remove the prop from hook (B).

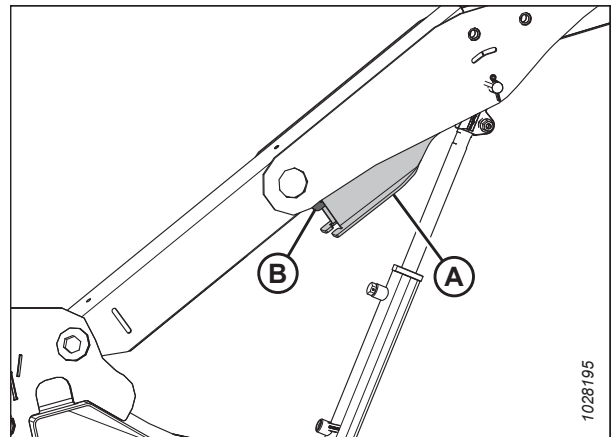

Figure 10.12: Outer Arm

4. Lower safety prop (A) and engage it on the cylinder shaft as shown. Repeat this step on the opposite reel arm.

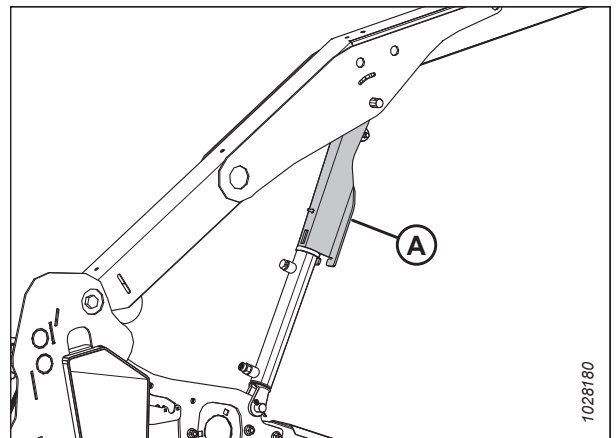

Figure 10.13: Engaged Reel Safety Prop – Outer Arm

REFERENCE

Center reel arm – double-reel headers

5. Rotate handle (A) to release the spring tension and allow the spring to guide the pin into the locked position.
6. Lower the reel until the safety props contact the outer arm cylinder mounts and the center arm pins.
7. Shut down the engine, and remove the key from the ignition.

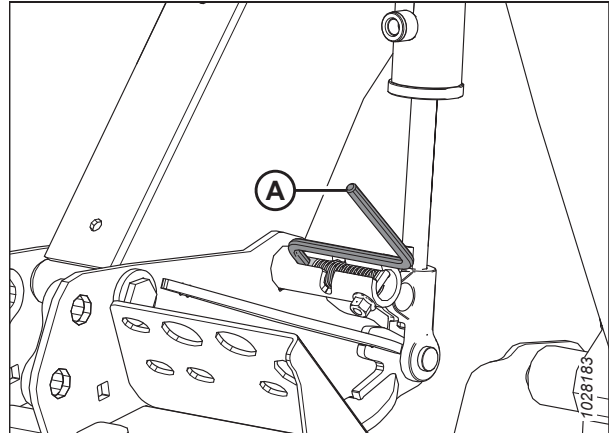

Figure 10.14: Engaged Reel Safety Prop – Center Arm

10.3.2 Disengaging Reel Safety Props

Disengage the reel safety props once you have completed working on or around a raised reel.

DANGER

To prevent injury or death from the unexpected start-up of the machine, always stop the engine and remove the key from the ignition before leaving the operator's seat for any reason.

DANGER

Ensure that all bystanders have cleared the area.

1. Raise the reel fully.
2. Shut down the engine, and remove the key from the ignition.

Outer reel arms

3. Move reel safety prop (A) up onto hook (B) under the reel arm. Repeat this step on the opposite reel arm.

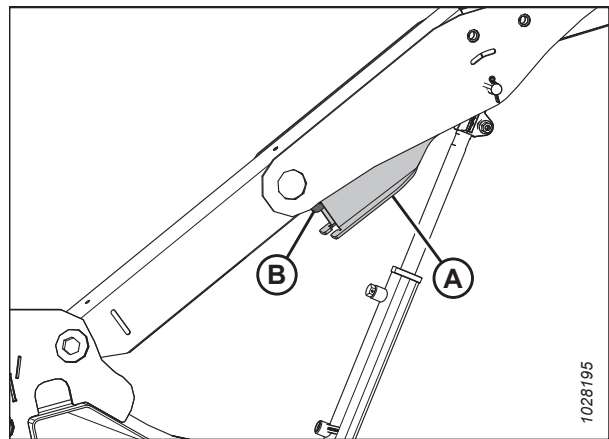

Figure 10.15: Reel Safety Prop – Right Outer Arm

REFERENCE

Center reel arm – double-reel headers

4. Move handle (A) outboard and into slot (B) to put the pin into the unlocked position.
5. Lower the reel fully.
6. Shut down the engine, and remove the key from the ignition.

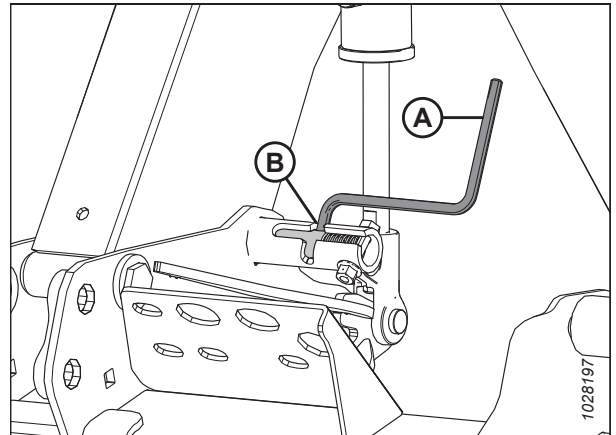

Figure 10.16: Reel Safety Prop – Center Arm

10.4 Header Endshields

A hinged, polyethylene endshield is fitted on each end of the header to protect critical drive components.

10.4.1 Opening Header Endshields

The header endshields cover the knife drive components, the hydraulic hoses, the electrical connections, the header wrench, the spare knife, and the optional transport hitch. To access these components, you will need to open the endshield.

1. To unlock the shield, push release lever (B) using access hole (A) on the backside of the header endshield.

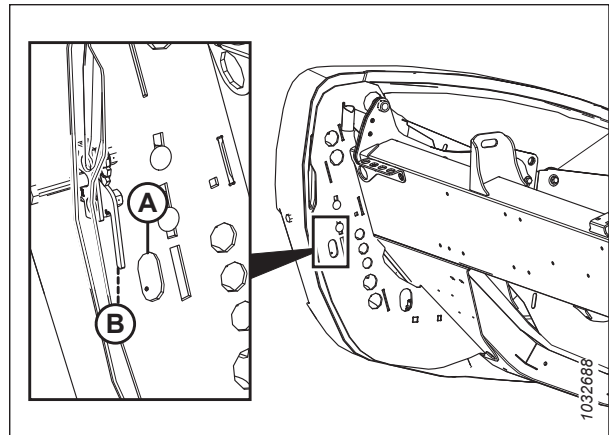

Figure 10.17: Left Header Endshield

2. Pull header endshield (A) open.

NOTE:

The header endshield is retained by tab (B) and will open in direction (C).

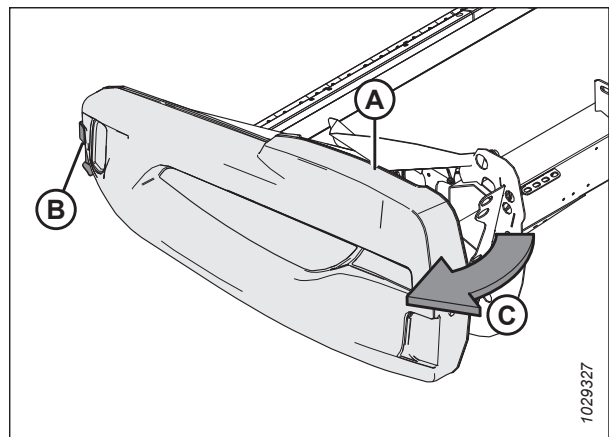

Figure 10.18: Left Header Endshield

REFERENCE

3. If additional clearance is required, pull the header endshield free of tab (A), then swing the shield toward the rear of the header.
4. Engage safety latch (B) on hinge arm (C) to secure the shield in the fully open position.

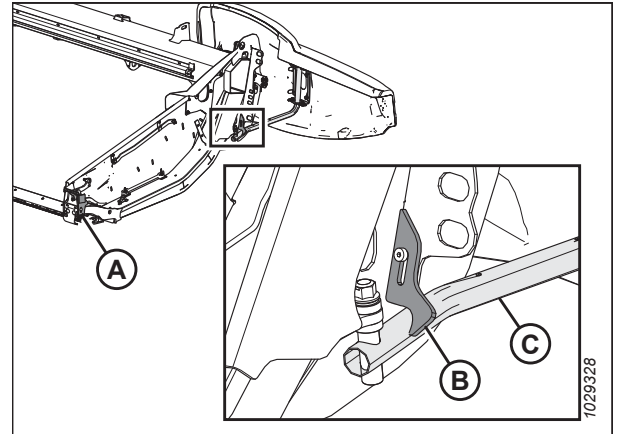

Figure 10.19: Left Header Endshield

10.4.2 Closing Header Endshields

Close the header endshields to protect the drive components, the hoses, and the electrical connections from dirt and debris.

1. If the endshield is fully open and secured behind the header, disengage lock (A) to allow header endshield (B) to move.
2. Rotate the header endshield toward the front of the header.

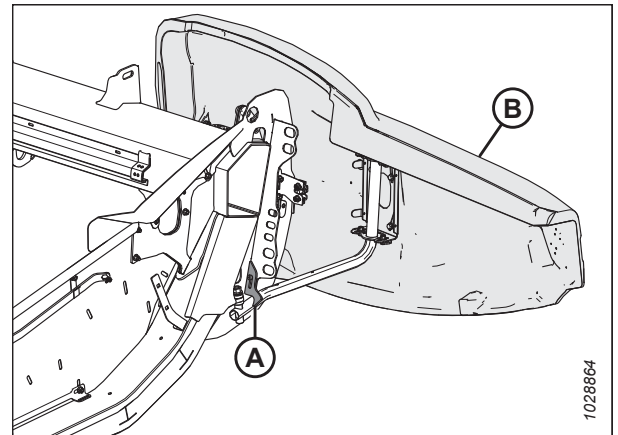

Figure 10.20: Left Header Endshield

3. While closing endshield (A), ensure that it does not contact the top of endsheet (B).

IMPORTANT:

Ensure that the header endshield does **NOT** rest on the aluminum endsheet.

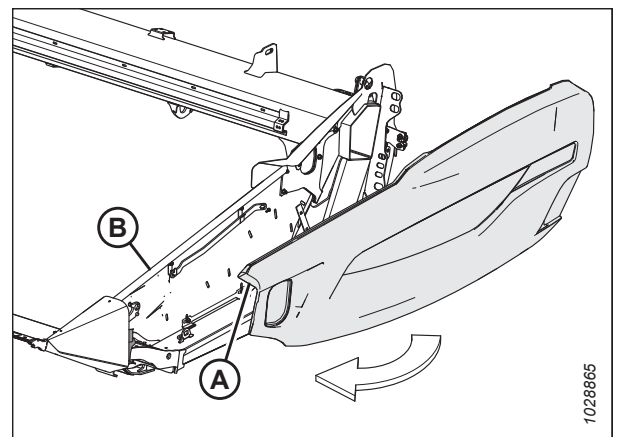

Figure 10.21: Left Header Endshield

REFERENCE

4. Insert the front of the header endshield behind hinge tab (B) and into the divider cone.
5. Swing the header endshield in direction (A) into the closed position. Engage two-stage latch (C) with a firm push.

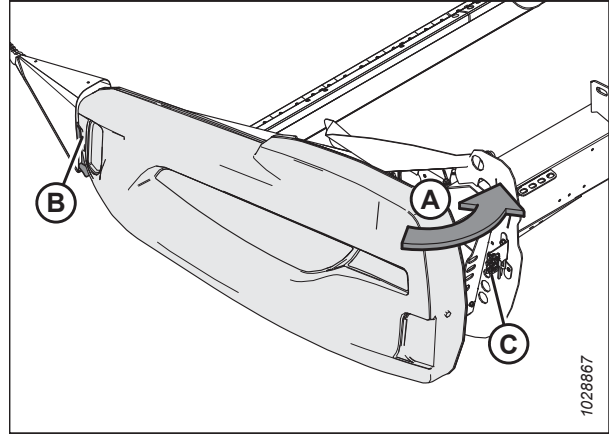

Figure 10.22: Left Header Endshield

IMPORTANT:

To ensure that the header endshield is locked, bolt (A) must be fully engaged on two-stage latch (B) to prevent the header endshield from opening while you are operating the header.

NOTE:

The header endshield is transparent in the illustration to show the latch.

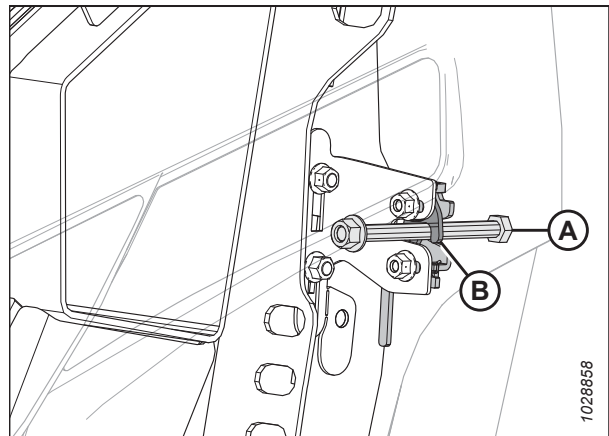

Figure 10.23: Two-Stage Latch

10.4.3 Removing Header Endshields

Remove the endshields to increase access to the components inside.

DANGER

To prevent bodily injury or death from the unexpected start-up of the machine, always stop the engine and remove the key from the ignition before leaving the operator's seat for any reason.

1. Shut down the engine, and remove the key from the ignition.

REFERENCE

2. Fully open the header endshield. For instructions, refer to [10.4.1 Opening Header Endshields, page 522](#).
3. Engage latch (A) to prevent the endshield from moving.
4. Remove self-tapping screw (B).
5. Slide the header endshield upward and remove it from hinge arm (C).
6. Place the header endshield away from the work area.

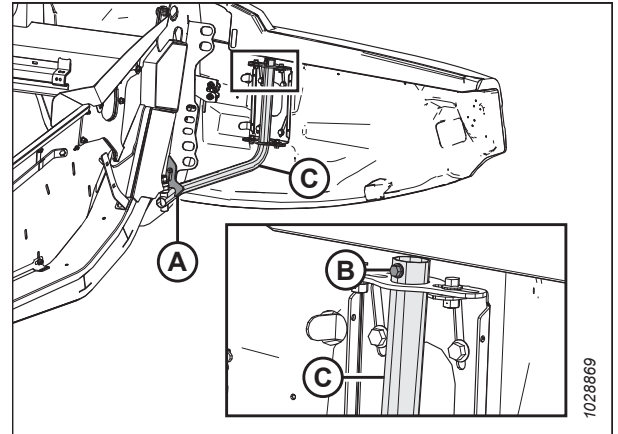

Figure 10.24: Left Header Endshield

10.4.4 Installing Header Endshields

To ensure that the endshields are installed correctly, follow the procedure provided here.

IMPORTANT:

Ensure that the header endshield does **NOT** rest on the aluminum endsheet.

1. Guide the header endshield onto hinge arm (C) and slowly slide it downwards.
2. Install self-tapping screw (B).
3. Disengage latch (A) to allow the header endshield to move.
4. Close the header endshield. For instructions, refer to [10.4.2 Closing Header Endshields, page 523](#).

NOTE:

The header endshields can warp due to extreme changes in temperature. Adjust the position of the header endshield to compensate for these changes. For instructions, refer to [6.15 Checking and Adjusting Header Endshields, page 253](#).

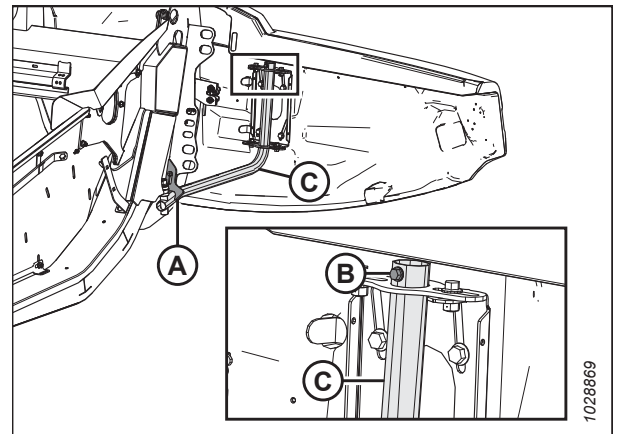

Figure 10.25: Left Header Endshield

10.5 Leveling Header

The float module is set at the factory to provide the proper level for the header and should not normally require adjustment. However, if adjustment is required, a procedure for doing so is provided.

Before attempting to level the header, ensure the following:

- Ensure that the combine's tires are inflated to the correct pressure.
- Ensure that the combine's feeder house is level. For instructions, refer to the combine operator's manual.
- Ensure that the top of the float module is level and is parallel with the combine's feeder house by checking the spirit level on the float module.

IMPORTANT:

The float springs are **NOT** used to level the header.

If the header still is not level, perform the following steps:



DANGER

To prevent injury or death from the unexpected start-up of the machine, always stop the engine and remove the key from the ignition before leaving the operator's seat for any reason.



DANGER

Ensure that all bystanders have cleared the area.

1. Start the engine.
2. Park the combine on a level surface.
3. Inspect the header to determine which side is too high, and which side is too low.
4. Shut down the engine, and remove the key from the ignition.
5. Check, and if necessary, adjust the float. For instructions, refer to [6.10 Checking and Adjusting Header Float, page 229](#).

REFERENCE

- Disengage both of the header float locks by pulling float lock handle (A) away from the float module and push the float lock handle down and into position (B) (UNLOCK).

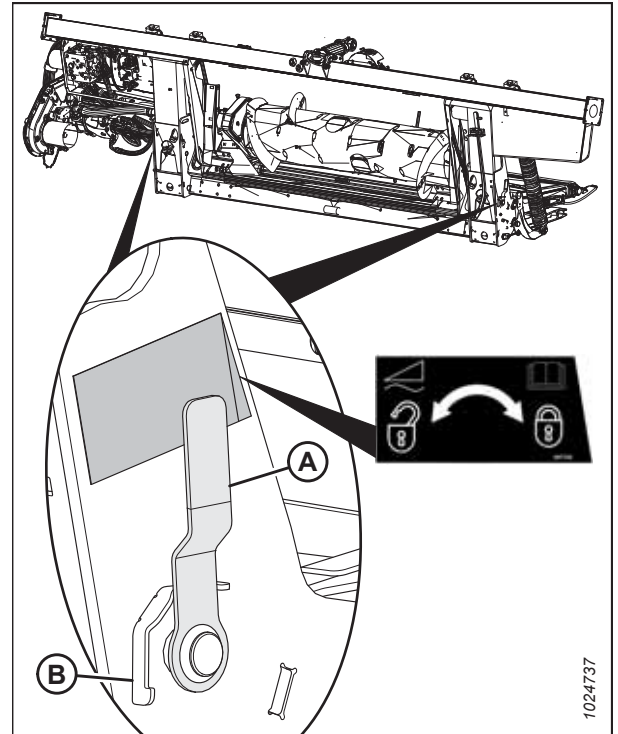

Figure 10.26: Header Float Lock in Locked Position

- On the high side of the header, make one small ($1/4$ – $1/2$ turn) counterclockwise adjustment to nut (A). Do **NOT** make any further adjustments to the float lock nut on this side of the header yet.

IMPORTANT:

Adjusting nut (A) more than two turns in either direction may adversely affect the header float.

NOTE:

Turning the float lock nut clockwise raises that side of the header; turning it counterclockwise lowers that side of the header.

NOTE:

Set screw (B) does not require loosening for adjustments of up to one-half turn of nut (A).

- Make the same adjustment to the float lock nut on the low side of the header in the counterclockwise direction. For example, if an adjustment of $1/4$ turn counterclockwise was made on the high side of the header, make an adjustment of $1/4$ turn clockwise on the low side of the header.

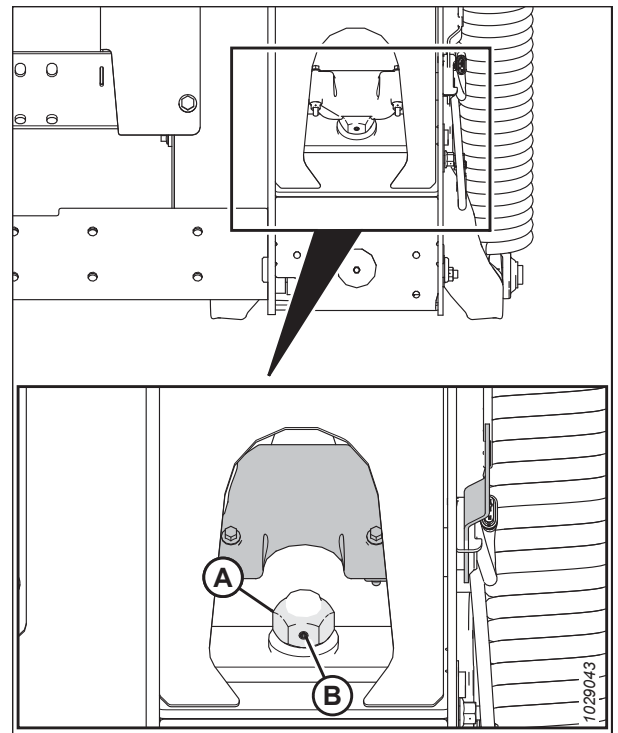

Figure 10.27: Float Lock – Right

REFERENCE

- Reset the float indicator to zero by loosening bolt (A) and sliding float indicator plate (B) until pointer (C) is on **0** (D). Tighten the nut on bolt (A).

NOTE:

Use zero dot (E) above the decal to correctly set the indicator needle.

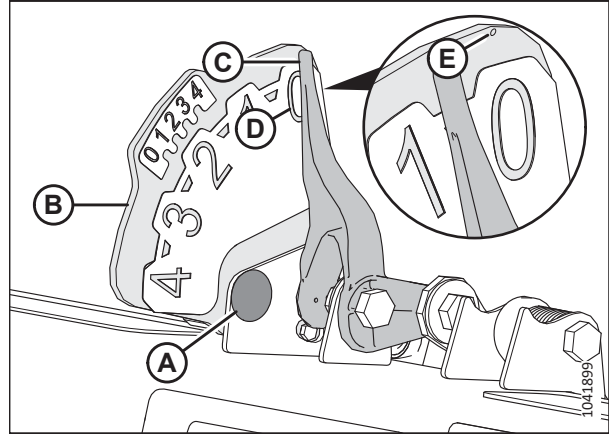

Figure 10.28: Float Indicator

- Ensure that there is a minimum clearance of 2–3 mm (1/8 in.) (A) between the frame and the back of the bell crank lever.
- Check the float after leveling the header. For instructions, refer to [6.10 Checking and Adjusting Header Float, page 229](#).

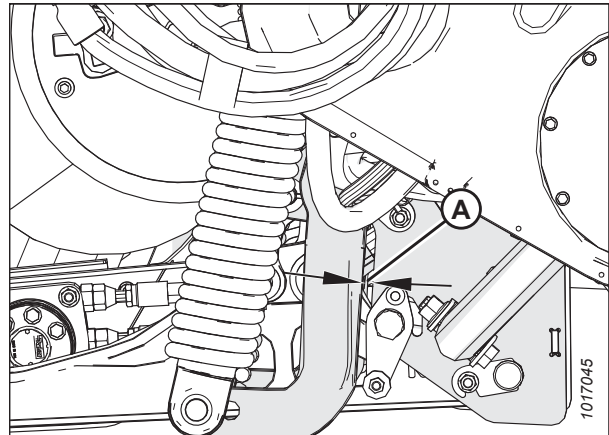

Figure 10.29: Bell Crank

10.6 Torque Specifications

The following tables provide torque values for various bolts, cap screws, and hydraulic fittings. Refer to these values only when no other torque value has been specified in a given procedure.

- Tighten all bolts to the torque values specified in the charts below, unless you are directed otherwise in this manual.
- Replace removed hardware with hardware of the same strength and grade.
- Refer to the torque value tables as a guide when periodically checking the tightness of bolts.
- Understand the torque categories for bolts and cap screws by reading the markings on their heads.

Jam nuts

Jam nuts require less torque than nuts used for other purposes. When applying torque to finished jam nuts, multiply the torque applied to regular nuts by 0.65 to obtain the modified torque value.

Self-tapping screws

Refer to the standard torque values when installing the self-tapping screws. Do **NOT** install the self-tapping screws on structural or otherwise critical joints.

10.6.1 Metric Bolt Specifications

Specifications are provided for the appropriate final torque values to secure various sizes of metric bolts.

NOTE:

The torque values provided in the following metric bolt torque tables apply to hardware installed dry; that is, hardware with no grease, oil, or threadlocker on the threads or heads. Do **NOT** add grease, oil, or threadlocker to bolts or cap screws unless you are directed to do so in this manual.

Table 10.5 Metric Class 8.8 Bolts and Class 9 Free Spinning Nut

Nominal Size (A)	Torque (Nm)		Torque (lbf-ft) (*lbf-in)	
	Min.	Max.	Min.	Max.
3-0.5	1.4	1.6	*13	*14
3.5-0.6	2.2	2.5	*20	*22
4-0.7	3.3	3.7	*29	*32
5-0.8	6.7	7.4	*59	*66
6-1.0	11.4	12.6	*101	*112
8-1.25	28	30	20	23
10-1.5	55	60	40	45
12-1.75	95	105	70	78
14-2.0	152	168	113	124
16-2.0	236	261	175	193
20-2.5	460	509	341	377
24-3.0	796	879	589	651

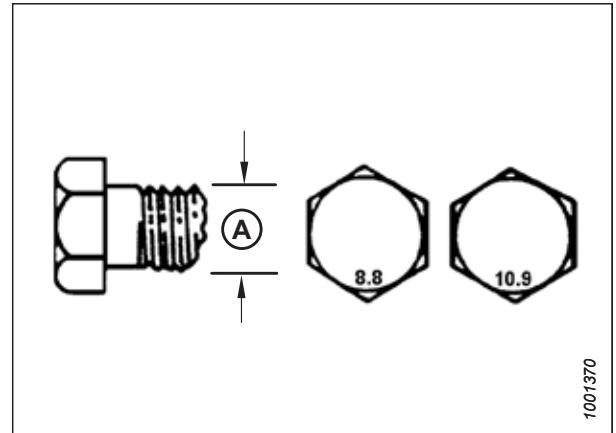

Figure 10.30: Bolt Grades

REFERENCE

Table 10.6 Metric Class 8.8 Bolts and Class 9 Distorted Thread Nut

Nominal Size (A)	Torque (Nm)		Torque (lbf-ft) (*lbf-in)	
	Min.	Max.	Min.	Max.
3-0.5	1	1.1	*9	*10
3.5-0.6	1.5	1.7	*14	*15
4-0.7	2.3	2.5	*20	*22
5-0.8	4.5	5	*40	*45
6-1.0	7.7	8.6	*69	*76
8-1.25	18.8	20.8	*167	*185
10-1.5	37	41	28	30
12-1.75	65	72	48	53
14-2.0	104	115	77	85
16-2.0	161	178	119	132
20-2.5	314	347	233	257
24-3.0	543	600	402	444

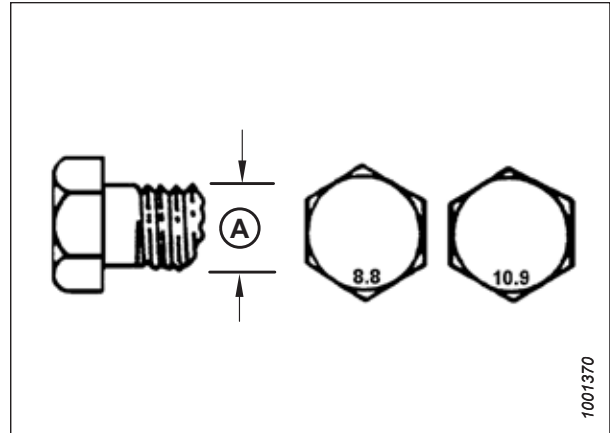

Figure 10.31: Bolt Grades

Table 10.7 Metric Class 10.9 Bolts and Class 10 Free Spinning Nut

Nominal Size (A)	Torque (Nm)		Torque (lbf-ft) (*lbf-in)	
	Min.	Max.	Min.	Max.
3-0.5	1.8	2	*18	*19
3.5-0.6	2.8	3.1	*27	*30
4-0.7	4.2	4.6	*41	*45
5-0.8	8.4	9.3	*82	*91
6-1.0	14.3	15.8	*140	*154
8-1.25	38	42	28	31
10-1.5	75	83	56	62
12-1.75	132	145	97	108
14-2.0	210	232	156	172
16-2.0	326	360	242	267
20-2.5	637	704	472	521
24-3.0	1101	1217	815	901

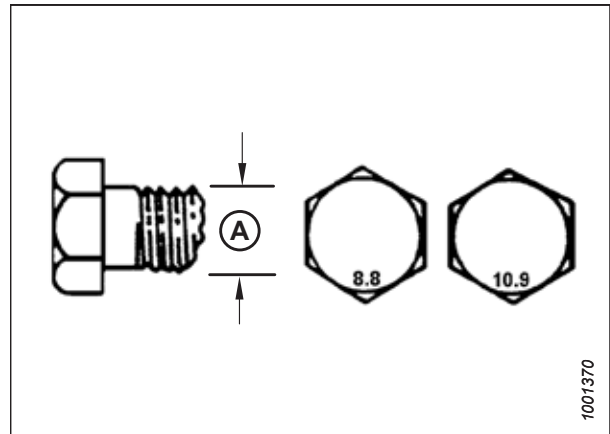

Figure 10.32: Bolt Grades

REFERENCE

Table 10.8 Metric Class 10.9 Bolts and Class 10 Distorted Thread Nut

Nominal Size (A)	Torque (Nm)		Torque (lbf-ft) (*lbf-in)	
	Min.	Max.	Min.	Max.
3-0.5	1.3	1.5	*12	*13
3.5-0.6	2.1	2.3	*19	*21
4-0.7	3.1	3.4	*28	*31
5-0.8	6.3	7	*56	*62
6-1.0	10.7	11.8	*95	*105
8-1.25	26	29	19	21
10-1.5	51	57	38	42
12-1.75	90	99	66	73
14-2.0	143	158	106	117
16-2.0	222	246	165	182
20-2.5	434	480	322	356
24-3.0	750	829	556	614

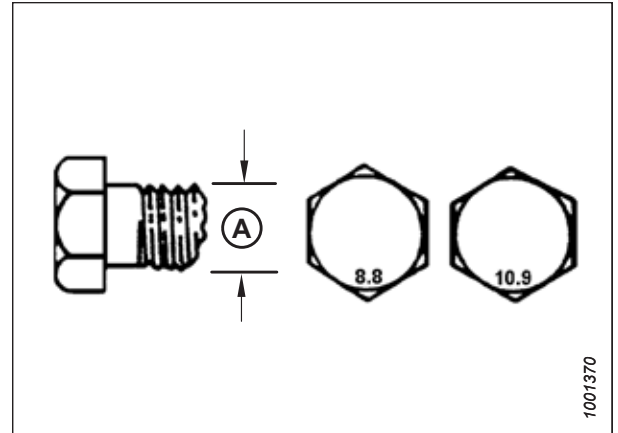

Figure 10.33: Bolt Grades

10.6.2 Metric Bolt Specifications – Cast Aluminum

Specifications are provided for the appropriate final torque values for various sizes of metric bolts in cast aluminum.

NOTE:

The torque values provided in the following metric bolt torque tables apply to hardware installed dry; that is, hardware with no grease, oil, or threadlocker on the threads or heads. Do **NOT** add grease, oil, or threadlocker to bolts or cap screws unless you are directed to do so in this manual.

Table 10.9 Metric Bolt Bolting into Cast Aluminum

Nominal Size (A)	Bolt Torque			
	8.8 (Cast Aluminum)		10.9 (Cast Aluminum)	
	Nm	lbf-ft	Nm	lbf-ft
M3	–	–	–	1
M4	–	–	4	2.6
M5	–	–	8	5.5
M6	9	6	12	9
M8	20	14	28	20
M10	40	28	55	40
M12	70	52	100	73
M14	–	–	–	–
M16	–	–	–	–

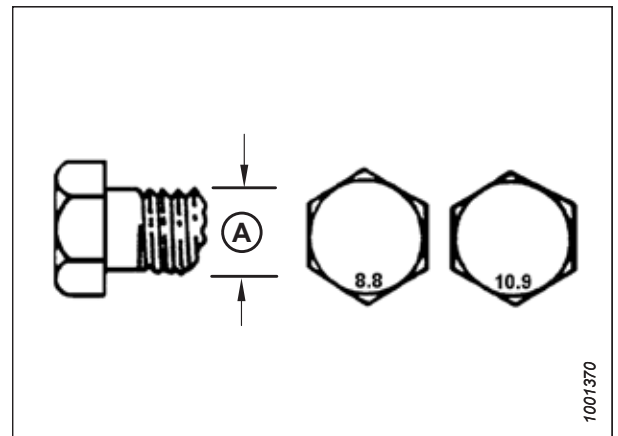

Figure 10.34: Bolt Grades

10.6.3 O-Ring Boss Hydraulic Fittings – Adjustable

The standard torque values are provided for adjustable hydraulic fittings. If a procedure specifies a different torque value for the same type and size of fitting found in this topic, refer to the value specified in the procedure instead.

1. Inspect O-ring (A) and seat (B) for dirt or defects.
2. Back off lock nut (C) as far as possible. Ensure that washer (D) is loose and that it is pushed toward lock nut (C) as far as possible.
3. Ensure that O-ring (A) is **NOT** on the threads. Adjust O-ring (A) if necessary.
4. Apply hydraulic system oil to O-ring (A).

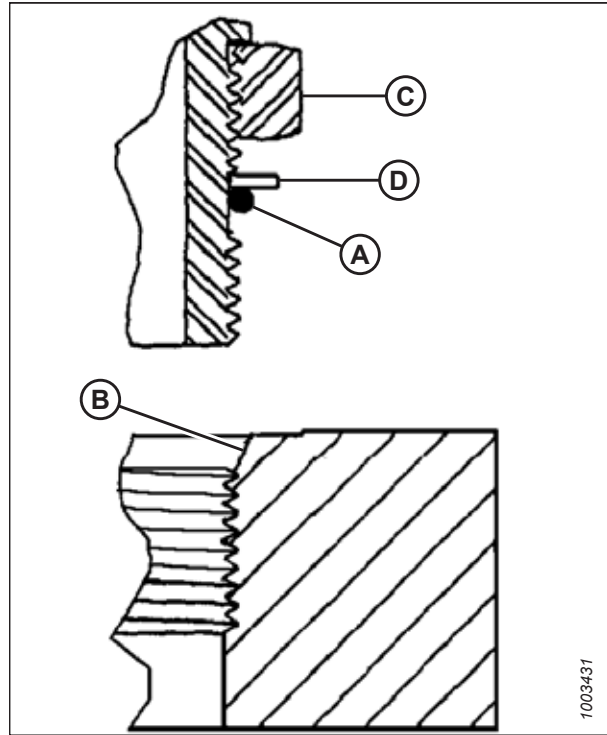

Figure 10.35: Hydraulic Fitting

5. Install fitting (B) into the port until backup washer (D) and O-ring (A) contact part face (E).
6. Position the angle fittings by unscrewing no more than one turn.
7. Turn lock nut (C) down to washer (D) and tighten it to the torque value indicated in the table. Use two wrenches, one on fitting (B) and the other on lock nut (C).
8. Verify the final condition of the fitting.

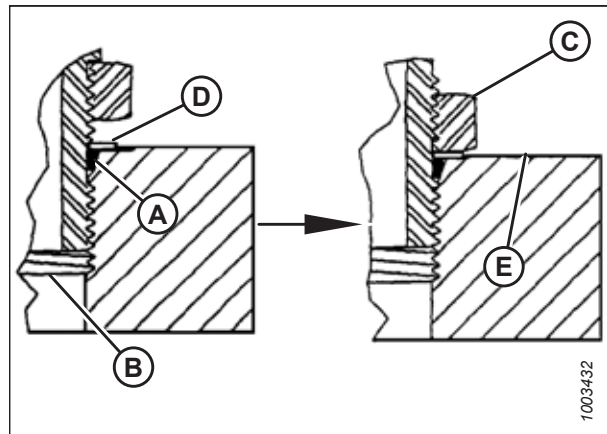

Figure 10.36: Hydraulic Fitting

REFERENCE

Table 10.10 O-Ring Boss (ORB) Hydraulic Fittings – Adjustable and Non-Adjustable

SAE Dash Size	Thread Size (in.)	Torque Value ³¹	
		Nm	lbf-ft (*lbf-in)
-2	5/16–24	10–11	*89–97
-3	3/8–24	18–20	*159–177
-4	7/16–20	29–32	21–24
-5	1/2–20	32–35	24–26
-6	9/16–18	40–44	30–32
-8	3/4–16	70–77	52–57
-10	7/8–14	115–127	85–94
-12	1 1/16–12	183–201	135–148
-14	1 3/16–12	237–261	175–193
-16	1 5/16–12	271–298	200–220
-20	1 5/8–12	339–373	250–275
-24	1 7/8–12	414–455	305–336
-32	2 1/2–12	509–560	375–413

10.6.4 O-Ring Boss Hydraulic Fittings – Non-Adjustable

The standard torque values for non-adjustable hydraulic fittings are provided. If a procedure specifies a different torque value for the same type and size of fitting found in this topic, use the value specified in the procedure instead.

1. Inspect O-ring (A) and seat (B) for dirt or defects.
2. Ensure that O-ring (A) is **NOT** on the threads. Adjust O-ring (A) if necessary.
3. Apply hydraulic system oil to the O-ring.
4. Install fitting (C) into the port until the fitting is hand-tight.
5. Torque fitting (C) according to values in Table 10.11, page 533.
6. Verify the final condition of the fitting.

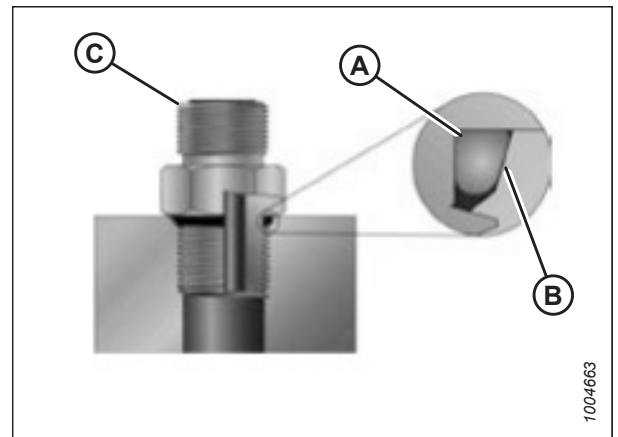

Figure 10.37: Hydraulic Fitting

Table 10.11 O-Ring Boss (ORB) Hydraulic Fittings – Adjustable and Non-Adjustable

SAE Dash Size	Thread Size (in.)	Torque Value ³¹	
		Nm	lbf-ft (*lbf-in)
-2	5/16–24	10–11	*89–97
-3	3/8–24	18–20	*159–177
-4	7/16–20	29–32	21–24
-5	1/2–20	32–35	24–26

31. Torque values shown are based on lubricated connections as in reassembly.

REFERENCE

Table 10.11 O-Ring Boss (ORB) Hydraulic Fittings – Adjustable and Non-Adjustable (continued)

SAE Dash Size	Thread Size (in.)	Torque Value ³²	
		Nm	lbf·ft (*lbf·in)
-6	9/16-18	40-44	30-32
-8	3/4-16	70-77	52-57
-10	7/8-14	115-127	85-94
-12	1 1/16-12	183-201	135-148
-14	1 3/16-12	237-261	175-193
-16	1 5/16-12	271-298	200-220
-20	1 5/8-12	339-373	250-275
-24	1 7/8-12	414-455	305-336
-32	2 1/2-12	509-560	375-413

10.6.5 O-Ring Face Seal Hydraulic Fittings

The standard torque values are provided for O-ring face seal hydraulic fittings. If a procedure specifies a different torque value for the same type and size of fitting found in this topic, refer to the value specified in the procedure instead.

Torque values are shown in the Table 10.12, page 535.

1. Ensure that the sealing surfaces and the fitting threads are free of burrs, nicks, scratches, and any foreign material.



Figure 10.38: Hydraulic Fitting

32. Torque values shown are based on lubricated connections as in reassembly.

REFERENCE

2. Apply hydraulic system oil to O-ring (B).
3. Align the tube or hose assembly so that the flat face of sleeve (A) or (C) comes into full contact with O-ring (B).
4. Thread tube or hose nut (D) until it is hand-tight. The nut should turn freely until it bottoms out.
5. Torque the fittings according to values in Table 10.12, page 535.

NOTE:

If applicable, hold the hex flange on fitting body (E) to prevent the rotation of the fitting body and the hose when tightening fitting nut (D).

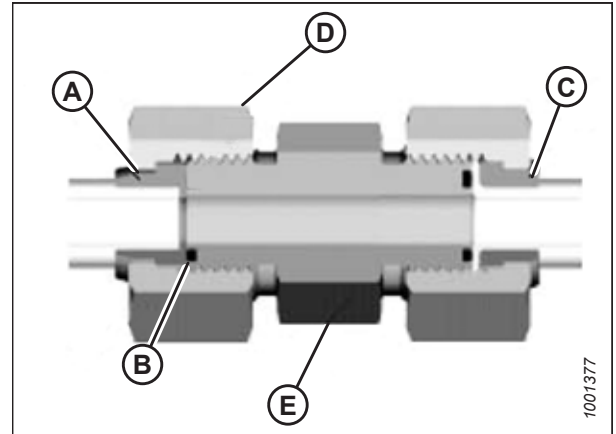

Figure 10.39: Hydraulic Fitting

6. Use three wrenches when assembling unions or joining two hoses together.
7. Verify the final condition of the fitting.

Table 10.12 O-Ring Face Seal (ORFS) Hydraulic Fittings

SAE Dash Size	Thread Size (in.)	Tube O.D. (in.)	Torque Value ³³	
			Nm	lbf-ft
-3	Note ³⁴	3/16	–	–
-4	9/16	1/4	25–28	18–21
-5	Note ³⁴	5/16	–	–
-6	11/16	3/8	40–44	30–32
-8	13/16	1/2	55–61	41–45
-10	1	5/8	80–88	59–65
-12	1 3/16	3/4	115–127	85–94
-14	Note ³⁴	7/8	–	–
-16	1 7/16	1	150–165	111–122
-20	1 11/16	1 1/4	205–226	151–167
-24	2	1 1/2	315–347	232–256
-32	2 1/2	2	510–561	376–414

10.6.6 Tapered Pipe Thread Fittings

The standard torque values are provided for tapered pipe thread fittings. If a procedure specifies a different torque value for the same type and size of fitting found in this topic, refer to the value specified in the procedure instead.

Assemble pipe fittings as follows:

1. Ensure that the fitting and the port threads are free of burrs, nicks, scratches, and any other form of contamination.
2. Apply paste-type pipe thread sealant to the external pipe threads.
3. Thread the fitting into the port until it is hand-tight.

33. Torque values and angles shown are based on lubricated connection as in reassembly.

34. O-ring face seal type end not defined for this tube size.

REFERENCE

4. Torque the connector to the appropriate torque angle. The turns from finger tight (TFFT) and flats from finger tight (FFFT) values are shown in Table 10.13, page 536. Ensure that the tube end of a shaped connector (typically a 45° or 90° elbow) is aligned to receive the incoming tube or hose assembly. Always finish the alignment of the fitting in the direction of tightening. Never loosen the threaded connectors to achieve alignment.
5. Clean all residue and any excess thread conditioner with an appropriate cleaner.
6. Inspect the final condition of the fitting. Pay special attention to the possibility of cracks in the port opening.
7. Mark the final position of the fitting. If a fitting leaks, disassemble the fitting and check it for damage.

NOTE:

The failure of fittings due to over-torquing may not be evident until the fittings are disassembled and inspected.

Table 10.13 Hydraulic Fitting Pipe Thread

Tapered Pipe Thread Size	Recommended TFFT	Recommended FFFT
1/8-27	2-3	12-18
1/4-18	2-3	12-18
3/8-18	2-3	12-18
1/2-14	2-3	12-18
3/4-14	1.5-2.5	12-18
1-11 1/2	1.5-2.5	9-15
1 1/4-11 1/2	1.5-2.5	9-15
1 1/2-11 1/2	1.5-2.5	9-15
2-11 1/2	1.5-2.5	9-15

REFERENCE

10.7 Conversion Chart

This manual uses both SI units (including metric) and US customary units (sometimes referred to as standard units) of measurement. A list of those units along with their abbreviations and conversion factors is provided here for your reference.

Table 10.14 Conversion Chart

Quantity	SI Units (Metric)		Factor	US Customary Units (Standard)	
	Unit Name	Abbreviation		Unit Name	Abbreviation
Area	hectare	ha	x 2.4710 =	acre	acres
Flow	liters per minute	L/min	x 0.2642 =	US gallons per minute	gpm
Force	Newton	N	x 0.2248 =	pound force	lbf
Length	millimeter	mm	x 0.0394 =	inch	in.
Length	meter	m	x 3.2808 =	foot	ft.
Power	kilowatt	kW	x 1.341 =	horsepower	hp
Pressure	kilopascal	kPa	x 0.145 =	pounds per square inch	psi
Pressure	megapascal	MPa	x 145.038 =	pounds per square inch	psi
Pressure	bar (Non-SI)	bar	x 14.5038 =	pounds per square inch	psi
Torque	Newton meter	Nm	x 0.7376 =	pound feet or foot pounds	lbf·ft
Torque	Newton meter	Nm	x 8.8507 =	pound inches or inch pounds	lbf·in
Temperature	degrees Celsius	°C	(°C x 1.8) + 32 =	degrees Fahrenheit	°F
Velocity	meters per minute	m/min	x 3.2808 =	feet per minute	ft/min
Velocity	meters per second	m/s	x 3.2808 =	feet per second	ft/s
Velocity	kilometers per hour	km/h	x 0.6214 =	miles per hour	mph
Volume	liter	L	x 0.2642 =	US gallon	US gal
Volume	milliliter	mL	x 0.0338 =	ounce	oz.
Volume	cubic centimeter	cm ³ or cc	x 0.061 =	cubic inch	in. ³
Weight	kilogram	kg	x 2.2046 =	pound	lb.

10.8 Definitions

The following terms, abbreviations, and acronyms are used in this instruction.

Table 10.15 Definitions

Term	Definition
AHHC	Automatic header height control
API	American Petroleum Institute
Bolt	A headed and externally threaded fastener designed to be paired with a nut
Center-link	A hydraulic cylinder or manually adjustable turnbuckle type connection between the header and the vehicle, which is used to change the angle of the header relative to the vehicle
CGVW	Combined gross vehicle weight
D2 Series Header	MacDon D225, D230, D235, D241, and D245 rigid draper headers for combines
Export header	The header configuration typical outside North America
FFFT	Flats from finger tight
Finger tight	A reference position in which the given sealing surfaces or components are making contact with each other. The fitting has been tightened by hand to a point where the fitting is no longer loose and cannot be tightened further by hand
FM200	The float module used with a D2 Series Draper Header for combining
FSI	Float setting indicator
GVW	Gross vehicle weight
Hard joint	A joint made with use of a fastener where joining materials are highly incompressible
Hex key	A tool of hexagonal cross-section used to drive bolts and screws that have a hexagonal socket in the head (internal-wrenching hexagon drive); also known as an Allen key
JIC	Joint Industrial Council: A standards body that developed standard sizing and shape for the original 37° flared fitting
n/a	Not applicable
North American header	The header configuration typical in North America
NPT	National Pipe Thread: A style of fitting used for low-pressure port openings. Threads on NPT fittings are uniquely tapered for an interference fit
Nut	An internally threaded fastener designed to be paired with a bolt
ORB	O-ring boss: A style of fitting commonly used in port openings on manifolds, pumps, and motors
ORFS	O-ring face seal: A style of fitting commonly used for connecting hoses and tubes. This style of fitting is also commonly called ORS, which stands for O-Ring Seal
PTO	Power take-off
rpm	Revolutions per minute
SAE	Society of Automotive Engineers
Screw	A headed and externally threaded fastener that threads into preformed threads or forms its own thread when it is inserted into a mating part
Soft joint	A flexible joint made by use of a fastener in which the joining materials compress or relax over a period of time
spm	Strokes per minute
Tension	An axial load placed on a bolt or screw, usually measured in Newtons (N) or pounds (lb.). This term can also be used to describe the force a belt exerts on a pulley or sprocket
TFFT	Turns from finger tight

REFERENCE

Table 10.15 Definitions (continued)

Term	Definition
Timed (knife drive)	Synchronized motion applied at the cutterbar to two separately driven knives from a single hydraulic motor
Torque	The product of a force * the length of a lever arm, usually measured in Newton-meters (Nm), foot-pounds (lbf·ft), or inch-pounds (lbf·in)
Torque angle	A tightening procedure in which a fitting is assembled to a specified tightness (usually finger tight) and then the nut is turned farther by a specified number of degrees until it achieves its final position
Torque-tension	The relationship between the assembly torque applied to a piece of hardware and the axial load it induces in a bolt or screw
UCA	Upper cross auger
Untimed (knife drive)	Unsynchronized motion applied at the cutterbar to two separately driven knives from a single hydraulic motor or from two hydraulic motors
Washer	A thin cylinder with a hole or a slot located in the center, used as a spacer, a load distribution element, or a locking mechanism

Predelivery Checklist

The predelivery checklist is used to confirm that all of the relevant assembly and testing procedures have been performed on the header before it is delivered to the customer.

Perform the checks listed in the table below before delivering the header to the Customer. Generally, adjustments to the header are not required after assembly is complete. If adjustments are required, refer to the relevant procedure specified in the table.

The completed checklist must be retained by either the Operator or the Dealer.

CAUTION

Carefully follow the instructions provided in this manual. Be alert for safety related messages that bring your attention to hazards and unsafe practices.

Header Serial Number:

Float Module Serial Number:

D2 Series Draper Header Predelivery Checklist – North America

✓	Item	Reference
	Ensure that the header has no shipping damage or missing parts and that all of the shipping materials have been removed.	—
	Check for loose hardware. Tighten any loose hardware to the specified torque value.	<i>10.6 Torque Specifications, page 529</i>
	If the header is equipped with stabilizer wheels, check the tire pressure on the stabilizer wheels.	<i>6.1 Checking Tire Pressure – Option for D230 and D235, page 203</i>
	If the header is equipped with stabilizer wheels, check the torque of the stabilizer wheel bolts.	<i>6.2 Checking Transport Wheel Bolt Torque – Option for D230 and D235, page 204</i>
	Check the lubricant level in the knife drive box.	<i>6.3 Checking Oil Level in Knife Drive Box, page 205</i>
	Check the lubricant level in the float module’s main drive gearbox.	<i>6.4 Checking Oil Level in Header Drive Main Gearbox, page 206</i>
	Check the lubricant level in the hydraulic reservoir before and after running up the header.	<i>6.6 Checking Oil Level in Hydraulic Reservoir, page 208</i>
	Ensure that the reel is centered between the header endsheets.	<i>6.8 Checking and Adjusting Reel-to-Endsheet Clearance, page 221</i>
	Grease all the bearings and the drivelines.	<i>6.14 Lubricating Header, page 243</i>
	Check the tension on the side drapers.	<i>6.12 Checking and Adjusting Side Draper Tension, page 238</i>
	Check the draper seal.	<i>6.13 Checking and Adjusting Draper Seal, page 240</i>
	Check the header float.	<i>6.10 Checking and Adjusting Header Float, page 229</i>
	Ensure that there is adequate clearance between the reel fingers and the cutterbar.	<i>6.9 Reel-to-Cutterbar Clearance, page 224</i>
	Ensure that there is adequate clearance between the auger and the feed pan.	<i>6.11 Adjusting Feed-Auger-to-Pan Clearance, page 235</i>

REFERENCE

D2 Series Draper Header Predelivery Checklist – North America

✓	Item	Reference
	Check the knife hold-downs.	<ul style="list-style-type: none"> • <i>6.7.1 Checking Hold-Down – Pointed Knife Guards, page 211</i> • <i>6.7.3 Checking Center Hold-Down on Double-Knife Header – Pointed Knife Guards, page 213</i> • <i>6.7.5 Checking Hold-Down – Short Knife Guards, page 215</i> • <i>6.7.7 Checking Center Hold-Down on Double-Knife Headers – Short Knife Guards, page 216</i>
	Ensure that the skid shoes are properly adjusted and at a setting appropriate for the crop.	—
	Ensure that the feeder house variable speed is set to minimum.	—
	Ensure that the auto header height control (AHHC) system is calibrated and functioning correctly.	<i>8.1 Auto Header Height Control System, page 265</i>
Run-up procedure		<i>9 Running up Header, page 499</i>
	Ensure that the reel rotates in the correct direction.	—
	Ensure that the hydraulic hoses and wiring harness have sufficient slack when the header and reel are raised and lowered.	—
	Ensure that the reel lift cylinders can extend fully.	—
	Ensure that the reel moves fully fore and aft.	—
	Check the knife speed.	<i>9.2 Checking and Adjusting Knife Speed – Dynamic Integrated Pump (MD #337774), page 503</i>
	Ensure that the side drapers track properly.	<i>9.3 Adjusting Side Draper Tracking, page 506</i>
Post run-up check. Stop the engine.		<i>9.4 Post Run-Up Adjustments, page 508</i>
	Ensure that the knife and reel drives do not have heated bearings.	<i>6.14 Lubricating Header, page 243</i>
	Check the knife sections for discoloration caused by misalignment of components. Adjust the hold-downs as required.	<i>9.4.1 Checking Knife Position, page 508</i>
	Ensure that the feed draper is properly tensioned.	<i>9.4.2 Checking and Adjusting Feed Draper Tension, page 509</i>
	Check for hydraulic leaks.	—
	Ensure that the header endshields can be fully opened and securely closed.	<i>6.15 Checking and Adjusting Header Endshields, page 253</i>
	Ensure that the manual storage case contains the operator’s manual, parts catalog, and quick card.	<i>6.16 Checking Manuals, page 258</i>

Date Checked:

Checked by:

Recommended Fluids and Lubricants

Ensure that your machine operates at top efficiency by using clean fluids and lubricants only.

- Use clean containers to handle all fluids and lubricants.
- Store fluids and lubricants in an area protected from dust, moisture, and other contaminants.

Lubricant	Specification	Description	Use	Capacities
Grease	SAE multi-purpose	High-temperature extreme-pressure (EP) performance with 1% max. molybdenum disulphide (NLGI Grade 2) lithium base	As required unless otherwise specified	—
		High-temperature extreme-pressure (EP) performance with 10% max. molybdenum disulphide (NLGI Grade 2) lithium base	Driveline slip-joints	—
Gear lubricant	SAE 85W-140	API service class GL-5	Knife drive box	1.5 liters (1.6 quarts)
			Main gearbox	2.75 liters (2.9 quarts)
			Completion gearbox	2.25 liters (2.4 quarts)
Hydraulic oil	<p>Single grade trans-hydraulic oil. Viscosity at 60.1 cSt @ 40°C (104°F) Viscosity at 9.5 cSt @ 100°C (212°F)</p> <p>Recommended Brands:</p> <ul style="list-style-type: none"> • Petro-Canada Duratran • John Deere Hy-Gard J20C • CNH Hy-Tran Ultratractor • CNH Hy-Tran Multitractor • AGCO Power Fluid 821 XL 	Lubricant trans / hydraulic oil	Header drive systems reservoir	95 liters (25.1 US gallons)
Chain oil	Chain oil with a viscosity of 100–150 sCt at 40°C (104°F) or mineral oil SAE 20W-50 that has no detergents or solvents	Chain oil is formulated to provide good wear protection and resistance to foaming. It protects the chain and drive sprockets against wear.	Reel drive chain	—

MacDon®

CUSTOMERS
MacDon.com

DEALERS
Portal.MacDon.com

Trademarks of products are the marks of their
respective manufacturers and/or distributors.

Printed in Canada