

QUICK REFERENCE CARD - NEW HOLLAND TR COMBINES

Combine Initial Settings

- Adjust front drum height to small grains position as per combine operators manual.

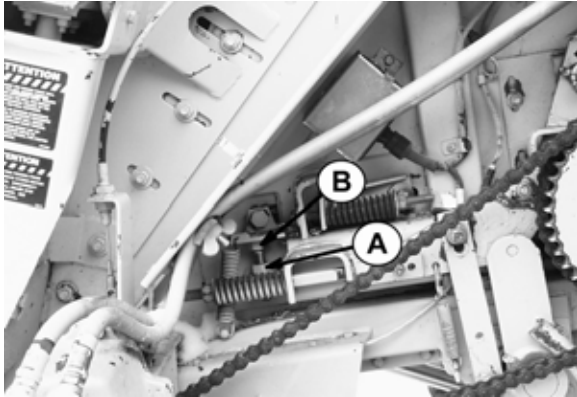

- For models with variable speed feeder house drive, set header output shaft speed to 575 rpm.
- Adjust feeder house faceplate rearward towards the cab to mid-position.

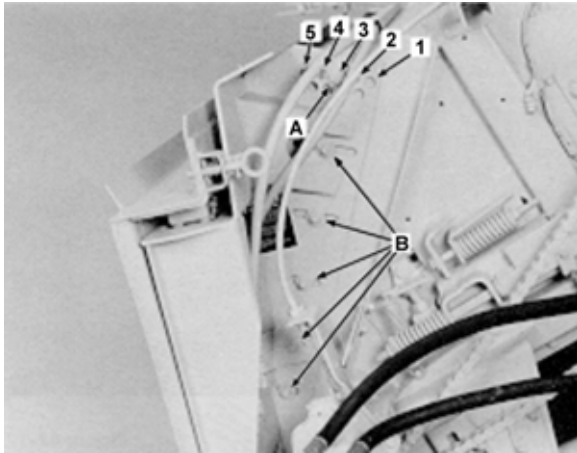

- Adjust stone ejection roll to raised position. See Combine Operator's Manual.

873 Adapter Initial Settings

- Place adapter float pin in proper hole for your header model as follows:
 - 963 headers in hole (E).
 - 972/973/974/84C headers in hole (C), (factory set) with dust shields and hole (E) with dust shields removed.
- Place adapter down stop pin in proper hole for your header model as follows:
 - 973/974/84C headers in hole (2), (factory set).
 - 963/972 headers in hole (3).

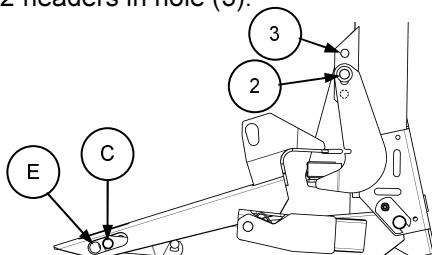

- If mounting adapter to a 974/84C header, move down stop pad to outboard set of holes (both sides) as shown. **NOTE:** If mounting to a 963/972/973 header, orientation is correct as shipped.

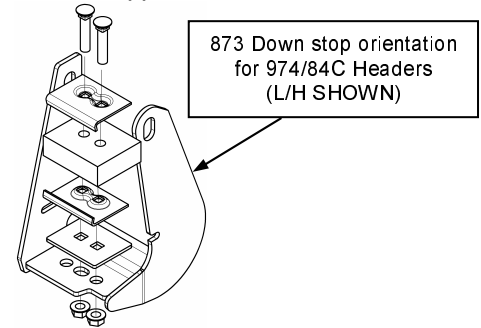

- Install skid plate on adapter feed pan so dim. D =
 - 4-11/32" (110 mm): 972/973/974/84C with dust shields on.
 - 3-1/2" (90 mm): 972/973/974/84C with dust shields off.
 - See page 40 of Op. Manual for adjustment details.

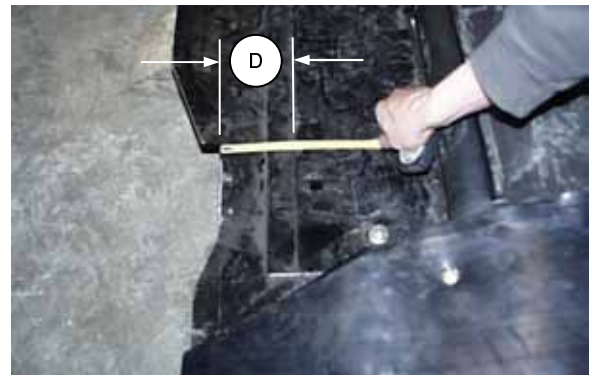

- Retracting Tine Drum Position:

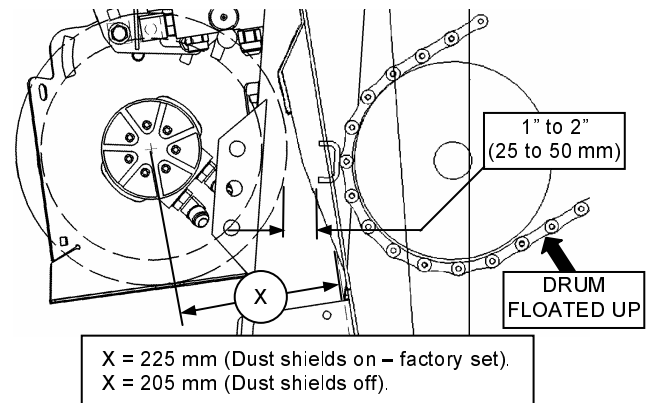

- Set the center link between the header and adapter to 19-1/4" (490 mm) length (pin to pin).
- Set the float to 30 lbs. at each crop divider at 6" cutterbar height. Use hook scale if necessary.
- Set the draper speed flow control so number "4" is at the 12 o'clock position.

QUICK REFERENCE CARD - NEW HOLLAND TR COMBINES

Header Initial Settings

- ❑ For 973 Model Headers: Set the center delivery opening to **36.6"** (930 mm).
- ❑ For 974 and 84C Model Headers: Set the

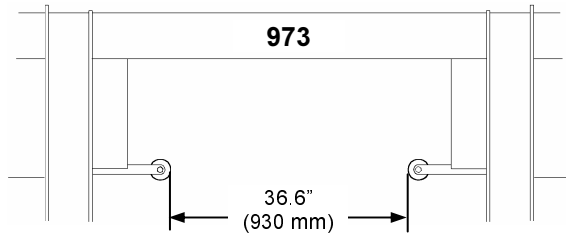

center delivery opening to **37.6"** (955 mm).

- ❑ Position the decks so there is equal

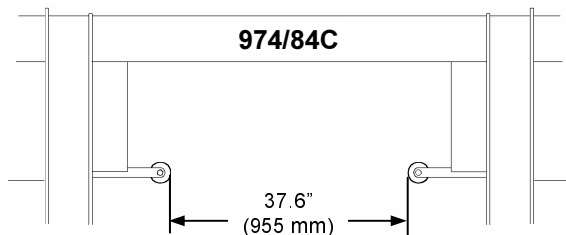

overlap of adapter feed draper each side.

- ❑ Align the vertical edge of the rear deflectors on the feed pan just inside the edge of the feeder house opening to ensure smooth crop flow.
- ❑ Set gauge wheels/transport to "Middle" stubble height. For standard gauge wheels, use hole (A). For transport gauge wheels, use hole (B).

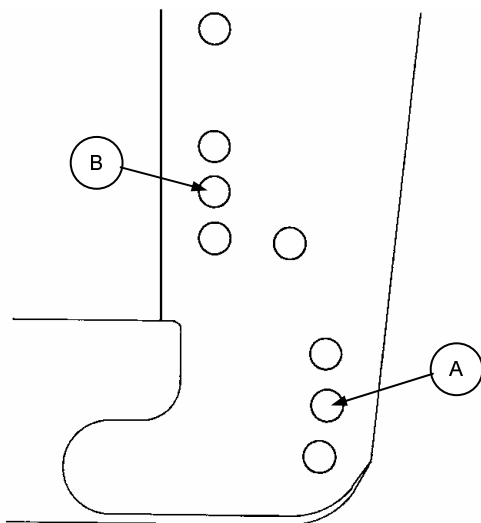

Pickup Reel Initial Settings

- ❑ Install bolt (C) through the cam arm with head inboard and torque to 120 ft. lbs. (162 N·m.)

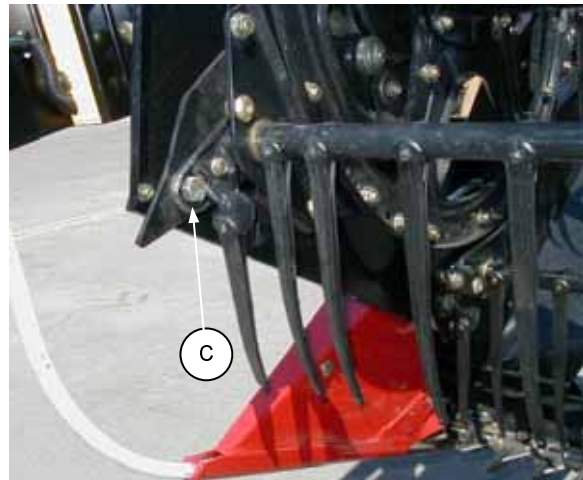

- ❑ Adjust the finger pitch to position **5**.

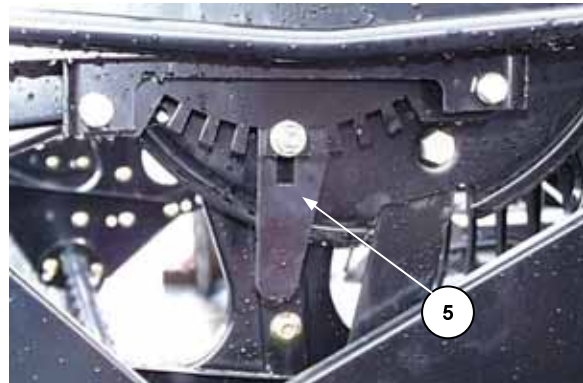

- ❑ Set the fore/aft position to between **4** and **5** on the gauge decal at left reel support arms.



- ❑ Reel finger to sickle guard minimum clearance with reel fully lowered is **5/8"** (15mm), **measured at both ends of the cutterbar. For 974/84C Headers, flex to full frown when checking clearance.**
- ❑ Recommended reel speed is 10% above ground speed.

QUICK REFERENCE CARD - NEW HOLLAND TR COMBINES

973 Initial Set-up

<u>Average Cereal Crops</u>	<u>Rice</u>		<u>Edible Beans</u>	
	<u>Normal Cutting</u>	<u>Tough Cutting</u>	<u>Dry Conditions</u>	<u>Wet Conditions</u>
Sickle --Check daily that guards are aligned. Clearance from hold down to sickle .020" (.05mm)	-	-	Stub Guard Kit is recommended.	Stub Guard Kit is recommended.
2100 reel Fore/Aft - 4 or 5 on decal Finger Pitch Adjustment - Slot 5 Reel Clearance - 5/8" (15mm) Speed - +10 % ground speed.	5 - - -	7 - - -	6 Slot 7 ½" (13mm) -	6 Slot 7 ½" (13mm) -
Draper Speed - Dial position "4". Draper opening - 36.6" (930 mm)	- -	Position"3 or 4" 41.7" (1060 mm)	- -	- -
Guard Angle - center link 19 ¼" (490 mm) length (pin to pin). Poly Skids - None	- Yes	- Yes	Center link fully extended. Yes	Center link fully extended. Yes
Gauge Wheels (if equipped) - Most cereals require "medium" stubble height setting	Not Applicable	Not Applicable	Short	Short
Float - Adjust float to 30 to 50 lbs. at dividers (6" cut height).	50 – 75 lbs.	50 – 75 lbs.	75 – 100 lbs.	30 – 50 lbs.

974/84C Initial Set-up

<u>Average Cereal Crops</u>	<u>Rice</u>		<u>Edible Beans</u>	
	<u>Normal Cutting</u>	<u>Tough Cutting</u>	<u>Dry Conditions</u>	<u>Wet Conditions</u>
Sickle --Check daily that guards are aligned. Clearance from hold down to sickle .020" (.05mm)	-	-	Stub Guard Kit is recommended.	Stub Guard Kit is recommended.
2100 reel Fore/Aft - 4 or 5 on decal Finger Pitch Adjustment - Slot 5 Reel Clearance - 5/8" (15mm) in full frown Speed - +10 % ground speed.	5 - - -	7 - - -	6 Slot 7 ½" (13mm) -	6 Slot 7 ½" (13mm) -
Draper Speed - Dial position "4". Draper opening - 37.6" (955 mm)	- -	Position"3 or 4" 42.7" (1085 mm)	- -	- -
Guard Angle - center link 19 ¼" (490 mm) length (pin to pin). Poly Skids - Standard	- Yes	- Yes	Center link fully extended. Yes	Center link fully extended. Yes
Gauge Wheels (if equipped) - Most cereals require "medium" stubble height setting	Not Applicable	Not Applicable	Short	Short
Float - Adjust float to 30 to 50 lbs. at dividers (1 to 6" cut height).	50 – 75 lbs.	50 – 75 lbs.	75 – 100 lbs.	30 – 50 lbs.