

Swath Compressor for M1 Series Windrowers

Setup, Operation, and Parts Manual

214286 Revision C

2017 Model Year

Original Instruction

Swath Compressor for M1 Series Windrowers

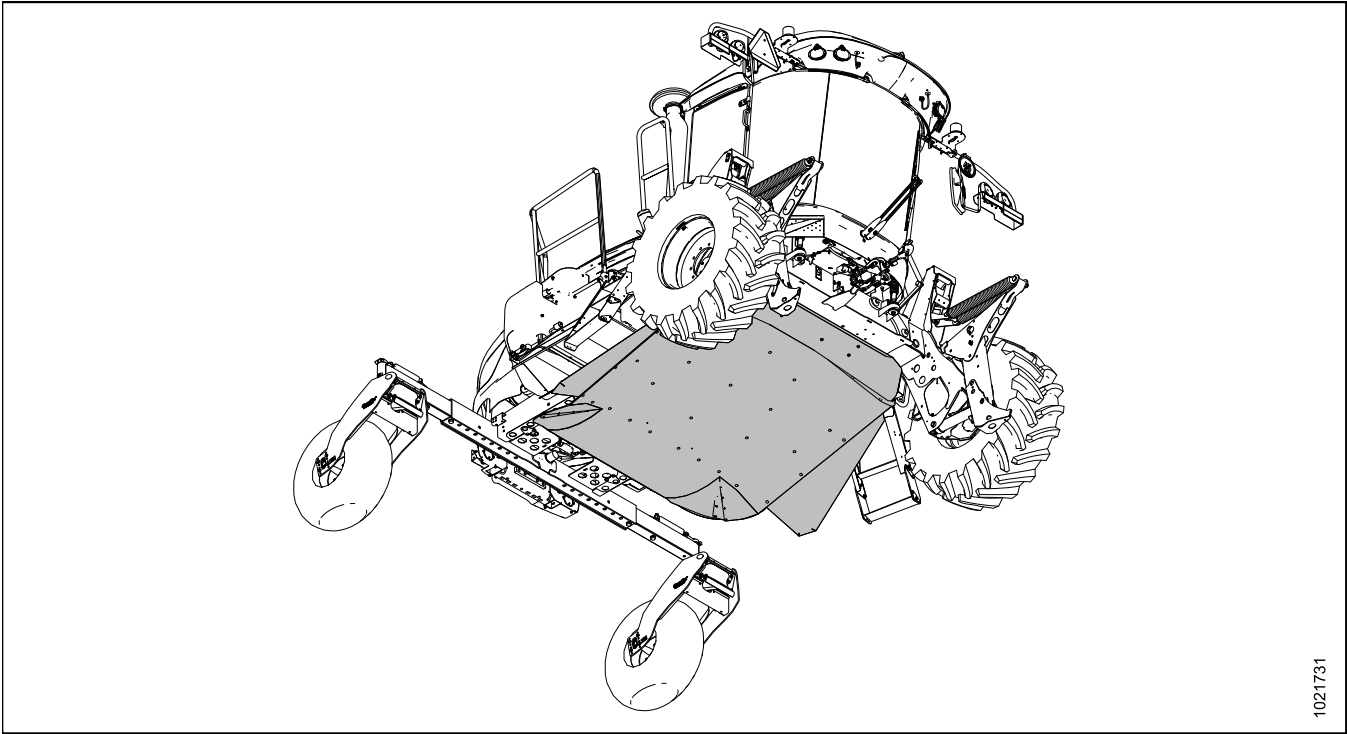

1021731

Published: July 2017

List of Revisions

At MacDon, we're continuously making improvements, and occasionally these improvements affect product documentation. The following list provides an account of major changes from the previous version of this document.

Summary of Change	Location
Added sentence that swath compressor was designed to work with D Series draper headers cutting canola.	Introduction, page iii
Added steps to use a forklift when removing the forming shield from shipping crate.	2.1 Removing Swath Compressor from Shipping Crate, page 11
<p>The following changes were made to the Installing Swath Compressor topic:</p> <ul style="list-style-type: none"> • Added steps to manage air cleaner support • Added steps to install washers between rear left/right supports and windrower frame • Added step to secure fuel filter sensor wire • Added steps and images (specific to M1170) to route hydraulics under windrower frame • Added steps to route hydraulic hoses under oil filters • Add step to secure hose sheath with cable ties • Added step to drive windrower into position overtop of forming shield • Added steps to move the side deflectors into working position • Added step recommending the use of two installers when lifting/connecting rear corner of shield 	2.2 Installing Swath Compressor on M1 Series Windrower, page 15
Added information that swath compressor down force is factory set to minimum.	3.2.3 Adjusting Down Force, page 32
<ul style="list-style-type: none"> • Added information that header with swath compressor icon is not displayed when no header is attached • Added step to raise swath compressor and engage lock when in engine forward mode or not in use 	3.2.5 Operating the Swath Compressor Lock, page 34
Added sentence: Do NOT sit on a lowered forming shield.	3.3 Removing the Swath Forming Shield, page 35

Summary of Change	Location
Changed the following items in the Parts List: <ul style="list-style-type: none"> • MD #136095 replaced by MD #136144 • Added MD #30635 x 2 • Added MD #21763 x 1 • Added MD #30753 x 2 	<i>4.2 Swath Compressor Hydraulics and Supports – Parts List, page 42</i>
Revised the Predelivery Checklist.	<i>Predelivery Checklist, page 59</i>

Introduction

The MacDon Swath Compressor is a large, formed polyethylene sheet which is designed to mount to the underside of a MacDon M1 Series Windrower. The MacDon Swath Compressor is designed for use with D Series Draper Headers cutting canola.

When lowered, the swath compressor shapes the windrow and anchors it into the stubble behind the header using a smooth, gradual transition that helps prevent shelling in ripe conditions. Too much compression by a swath compressor or roller can increase losses from crop shelling, and may increase dry-down time; inadequate compression can leave a windrow prone to wind damage.

The swath compressor height can be adjusted and monitored with the cab display. Height can be adjusted for crop ripeness, yield, and the amount of compression required. The swath compressor will automatically lift up if an Operator stops and reverses the windrower.

NOTE:

A preferred height can be saved under a One-Touch-Return preset.

When setting up the machine or making adjustments, review and follow the recommended machine settings in all relevant MacDon publications. Failure to do so may compromise machine function and machine life and may result in a hazardous situation.

MacDon provides warranty for Customers who operate and maintain their equipment as described in this manual. A copy of the MacDon Industries Limited Warranty Policy, which explains this warranty, should have been provided to you by your Dealer. Damage resulting from any of the following conditions will void the warranty:

- Accident
- Misuse
- Abuse
- Improper maintenance or neglect
- Abnormal or extraordinary use of the machine
- Failure to use the machine, equipment, component, or part in accordance with the manufacturer's instructions

NOTE:

Keep your MacDon publications up-to-date. The most current version can be downloaded from our website www.macdon.com or from our Dealer-only site (<https://portal.macdon.com>) (login required).

This manual is currently available in the English language only.

Conventions

M1 Series Windrowers are Dual Direction®, meaning the windrower can be driven in cab-forward or engine-forward modes. When referencing specific locations on the machine, this manual always assumes a cab-forward direction when using the terms right and left.

TABLE OF CONTENTS

List of Revisions	i
Introduction.....	iii
Chapter 1: Safety	1
1.1 Safety Alert Symbols	1
1.2 Signal Words	2
1.3 General Safety.....	3
1.4 Maintenance Safety	5
1.5 Hydraulic Safety.....	6
1.6 Welding Precaution	7
1.7 Safety Signs	8
1.7.1 Installing Safety Decals	8
1.8 Safety Sign Decals.....	9
Chapter 2: Assembly Instructions.....	11
2.1 Removing Swath Compressor from Shipping Crate	11
2.2 Installing Swath Compressor on M1 Series Windrower	15
Chapter 3: Operation	27
3.1 Activating the Swath Compressor.....	27
3.2 Operating the Swath Compressor.....	29
3.2.1 Setting up the Swath Compressor	31
3.2.2 Programming One-Touch-Return.....	32
3.2.3 Adjusting Down Force	32
3.2.4 Adjusting Side Deflectors.....	33
3.2.5 Operating the Swath Compressor Lock.....	34
3.3 Removing the Swath Forming Shield	35
Chapter 4: Parts	37
4.1 Swath Compressor Frame – Parts List.....	38
4.2 Swath Compressor Hydraulics and Supports – Parts List	42
4.3 Decals.....	46
Chapter 5: Reference	49
5.1 Torque Specifications	49
5.1.1 Metric Bolt Specifications	49
5.1.2 Metric Bolt Specifications Bolting into Cast Aluminum	51
5.1.3 O-Ring Boss (ORB) Hydraulic Fittings (Adjustable).....	52
5.1.4 O-Ring Boss (ORB) Hydraulic Fittings (Non-Adjustable).....	54
5.1.5 O-Ring Face Seal (ORFS) Hydraulic Fittings	55
5.1.6 Tapered Pipe Thread Fittings	56
5.2 Conversion Chart.....	57

TABLE OF CONTENTS

Predelivery Checklist..... 59
Index..... 61

1 Safety

1.1 Safety Alert Symbols

This safety alert symbol indicates important safety messages in this manual and on safety signs on the machine.

This symbol means:

- **ATTENTION!**
- **BECOME ALERT!**
- **YOUR SAFETY IS INVOLVED!**

Carefully read and follow the safety message accompanying this symbol.

Why is safety important to you?

- Accidents disable and kill
- Accidents cost
- Accidents can be avoided



Figure 1.1: Safety Symbol

1.2 Signal Words

Three signal words, **DANGER**, **WARNING**, and **CAUTION**, are used to alert you to hazardous situations. The appropriate signal word for each situation has been selected using the following guidelines:

DANGER

Indicates an imminently hazardous situation that, if not avoided, will result in death or serious injury.

WARNING

Indicates a potentially hazardous situation that, if not avoided, could result in death or serious injury. It may also be used to alert against unsafe practices.

CAUTION

Indicates a potentially hazardous situation that, if not avoided, may result in minor or moderate injury. It may be used to alert against unsafe practices.

1.3 General Safety

CAUTION

The following are general farm safety precautions that should be part of your operating procedure for all types of machinery.

Protect yourself.

- When assembling, operating, and servicing machinery, wear all protective clothing and personal safety devices that could be necessary for job at hand. Do **NOT** take chances. You may need the following:
 - Hard hat
 - Protective footwear with slip resistant soles
 - Protective glasses or goggles
 - Heavy gloves
 - Wet weather gear
 - Respirator or filter mask
- Be aware that exposure to loud noises can cause hearing impairment or loss. Wear suitable hearing protection devices such as earmuffs or ear plugs to help protect against loud noises.



Figure 1.2: Safety Equipment



Figure 1.3: Safety Equipment

- Provide a first aid kit for use in case of emergencies.
- Keep a fire extinguisher on the machine. Be sure fire extinguisher is properly maintained. Be familiar with its proper use.
- Keep young children away from machinery at all times.
- Be aware that accidents often happen when Operator is tired or in a hurry. Take time to consider safest way. Never ignore warning signs of fatigue.

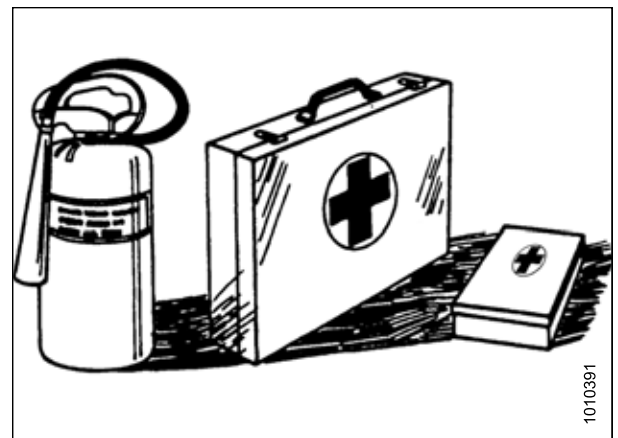

Figure 1.4: Safety Equipment

SAFETY

- Wear close-fitting clothing and cover long hair. Never wear dangling items such as scarves or bracelets.
- Keep all shields in place. **NEVER** alter or remove safety equipment. Make sure driveline guards can rotate independently of shaft and can telescope freely.
- Use only service and repair parts made or approved by equipment manufacturer. Substituted parts may not meet strength, design, or safety requirements.



Figure 1.5: Safety around Equipment

- Keep hands, feet, clothing, and hair away from moving parts. **NEVER** attempt to clear obstructions or objects from a machine while engine is running.
- Do **NOT** modify machine. Unauthorized modifications may impair machine function and/or safety. It may also shorten machine's life.
- To avoid bodily injury or death from unexpected startup of machine, **ALWAYS** stop the engine and remove the key from the ignition before leaving the operator's seat for any reason.

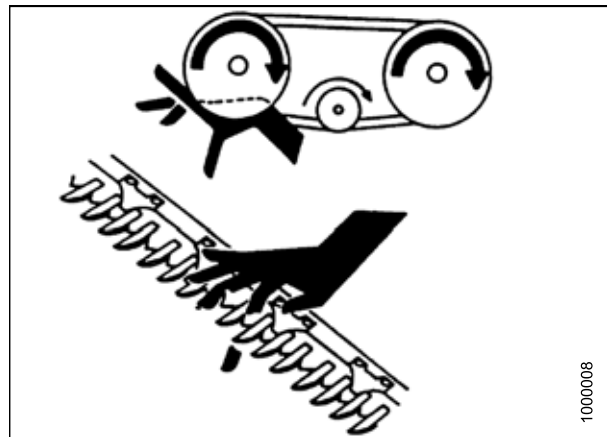

Figure 1.6: Safety around Equipment

- Keep service area clean and dry. Wet or oily floors are slippery. Wet spots can be dangerous when working with electrical equipment. Be sure all electrical outlets and tools are properly grounded.
- Keep work area well lit.
- Keep machinery clean. Straw and chaff on a hot engine is a fire hazard. Do **NOT** allow oil or grease to accumulate on service platforms, ladders, or controls. Clean machines before storage.
- **NEVER** use gasoline, naphtha, or any volatile material for cleaning purposes. These materials may be toxic and/or flammable.
- When storing machinery, cover sharp or extending components to prevent injury from accidental contact.



Figure 1.7: Safety around Equipment

1.4 Maintenance Safety

To ensure your safety while maintaining machine:

- Review operator's manual and all safety items before operation and/or maintenance of machine.
- Place all controls in Neutral, stop the engine, set the park brake, remove the ignition key, and wait for all moving parts to stop before servicing, adjusting, and/or repairing.
- Follow good shop practices:
 - Keep service areas clean and dry
 - Be sure electrical outlets and tools are properly grounded
 - Use adequate lighting for job at hand
- Relieve pressure from hydraulic circuits before servicing and/or disconnecting machine.
- Make sure all components are tight and that steel lines, hoses, and couplings are in good condition before applying pressure to hydraulic systems.
- Keep hands, feet, clothing, and hair away from all moving and/or rotating parts.
- Clear area of bystanders, especially children, when carrying out any maintenance, repairs, or adjustments.
- Install transport lock or place safety stands under frame before working under machine.
- If more than one person is servicing machine at same time, be aware that rotating a driveline or other mechanically-driven component by hand (for example, accessing a lube fitting) will cause drive components in other areas (belts, pulleys, and knives) to move. Stay clear of driven components at all times.
- Wear protective gear when working on machine.
- Wear heavy gloves when working on knife components.



Figure 1.8: Safety around Equipment

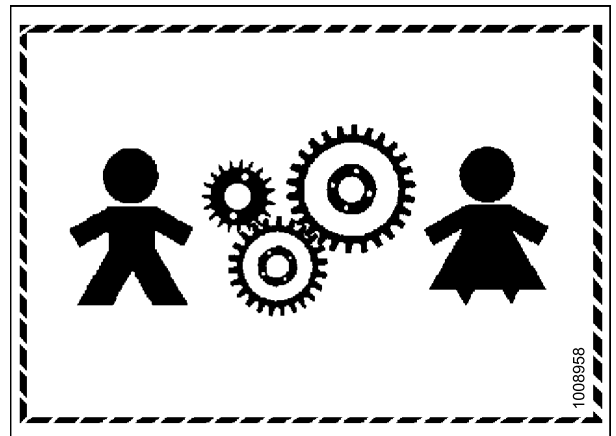

Figure 1.9: Equipment NOT Safe for Children



Figure 1.10: Safety Equipment

1.5 Hydraulic Safety

- Always place all hydraulic controls in Neutral before dismounting.
- Make sure that all components in hydraulic system are kept clean and in good condition.
- Replace any worn, cut, abraded, flattened, or crimped hoses and steel lines.
- Do **NOT** attempt any makeshift repairs to hydraulic lines, fittings, or hoses by using tapes, clamps, cements, or welding. The hydraulic system operates under extremely high pressure. Makeshift repairs will fail suddenly and create hazardous and unsafe conditions.

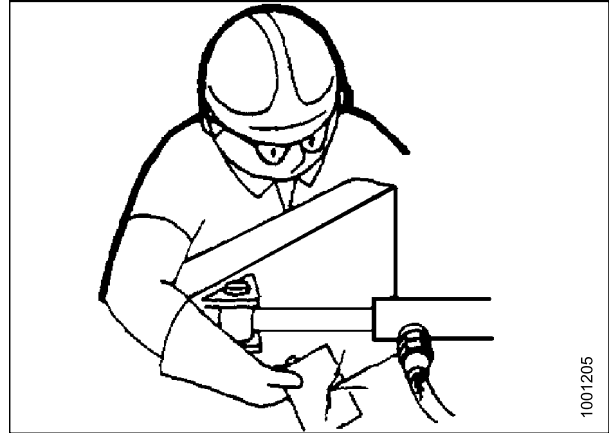

Figure 1.11: Testing for Hydraulic Leaks

- Wear proper hand and eye protection when searching for high-pressure hydraulic leaks. Use a piece of cardboard as a backstop instead of hands to isolate and identify a leak.
- If injured by a concentrated high-pressure stream of hydraulic fluid, seek medical attention immediately. Serious infection or toxic reaction can develop from hydraulic fluid piercing the skin.



Figure 1.12: Hydraulic Pressure Hazard

- Make sure all components are tight and steel lines, hoses, and couplings are in good condition before applying pressure to a hydraulic system.

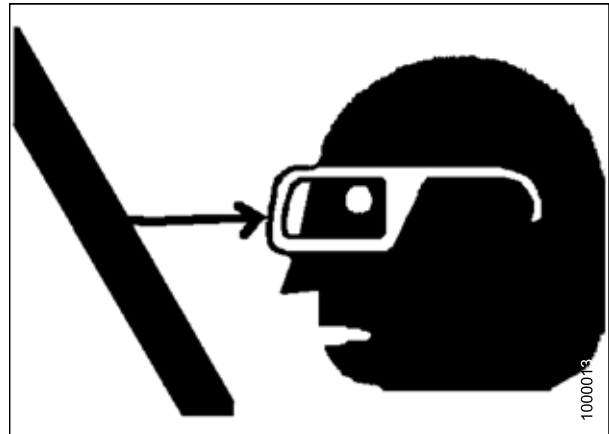

Figure 1.13: Safety around Equipment

1.6 Welding Precaution

Welding should never be attempted on the attachment while it is connected to a windrower.

WARNING

Severe damage to sensitive, expensive electronics can result from welding on the attachment while it is connected to the windrower. It is impossible to know what effect high current could have with regard to future malfunctions or shorter lifespan. It is very important that welding to the attachment frame is not attempted while connected to the windrower.

If an Operator needs to weld to the attachment frame, it should be removed from the windrower.

If the attachment can not be removed from the windrower, refer to the windrower's technical manual for welding precautions detailing electrical components that must be disconnected before welding.

SAFETY

1.7 Safety Signs

- Keep safety signs clean and legible at all times.
- Replace safety signs that are missing or become illegible.
- If original parts on which a safety sign was installed are replaced, be sure repair part also bears current safety sign.
- Replacement safety signs are available from your Dealer Parts Department.

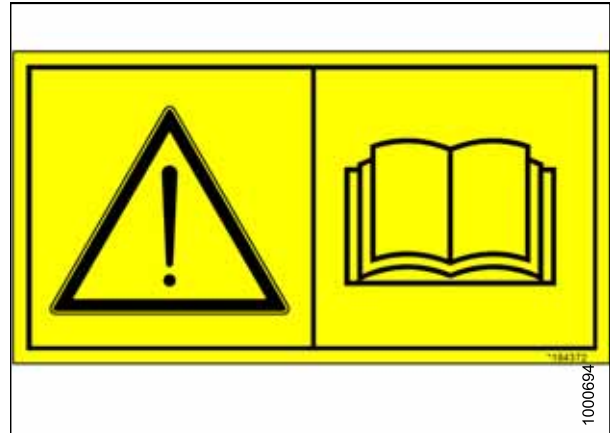

Figure 1.14: Operator's Manual Decal

1.7.1 Installing Safety Decals

1. Clean and dry installation area.
2. Decide on exact location before you remove decal backing paper.
3. Remove smaller portion of split backing paper.
4. Place sign in position and slowly peel back remaining paper, smoothing sign as it is applied.
5. Prick small air pockets with a pin and smooth out.

1.8 Safety Sign Decals

MD #184372

General hazard pertaining to machine operation and servicing.

CAUTION

- Read the operator's manual and follow all safety instructions. If you do not have a manual, obtain one from your Dealer.
- Do not allow untrained persons to operate the machine.
- Review safety instructions with all Operators every year.
- Ensure that all safety signs are installed and legible.
- Make certain everyone is clear of machine before starting engine and during operation.
- Keep riders off the machine.
- Keep all shields in place and stay clear of moving parts.
- Disengage header drive, put transmission in Neutral, and wait for all movement to stop before leaving operator's position.
- Stop the engine and remove the key from ignition before servicing, adjusting, lubricating, cleaning, or unplugging machine.
- Engage locks to prevent lowering of header or reel before servicing in the raised position.
- Use slow moving vehicle emblem and flashing warning lights when operating on roadways unless prohibited by law.

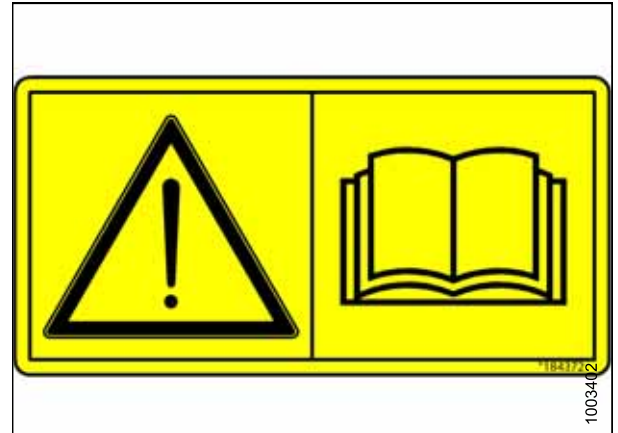

Figure 1.15: MD #184372

MD #166466

HIGH PRESSURE HYDRAULICS

DO NOT GO NEAR LEAKS

- High pressure oil easily punctures skin causing serious injury, gangrene or death.
- If injured, seek emergency medical help. Immediate surgery is required to remove oil.
- Do not use finger or skin to check for leaks.
- Lower load or relieve hydraulic pressure before loosening fittings.



Figure 1.16: MD #166466

SAFETY

MD #174683

PINCH POINT - MOVING PARTS

STAND CLEAR



Figure 1.17: MD #174683

MD #291638

LOCK - SWATH COMPRESSOR DECK

- Engage lock when swath compressor is not in use.
- Lock forming shield before servicing or working under the windrower.
- Lock forming shield before travelling in engine forward mode.



Figure 1.18: MD #291638

2 Assembly Instructions

2.1 Removing Swath Compressor from Shipping Crate

Follow these steps to unpack the swath compressor from the shipping crate. Retain all parts for installation unless instructed to discard.

1. Remove the top cross members (A) from shipping crate and discard.

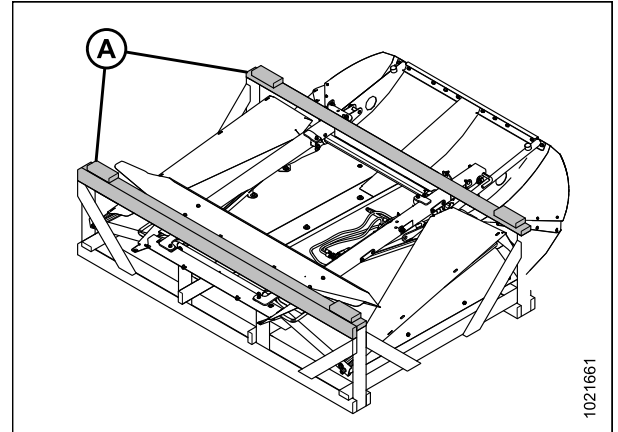

Figure 2.1: Shipping Configuration

2. Remove four bolts (A) securing deflector (B) to left and right supports, and remove deflector (B).

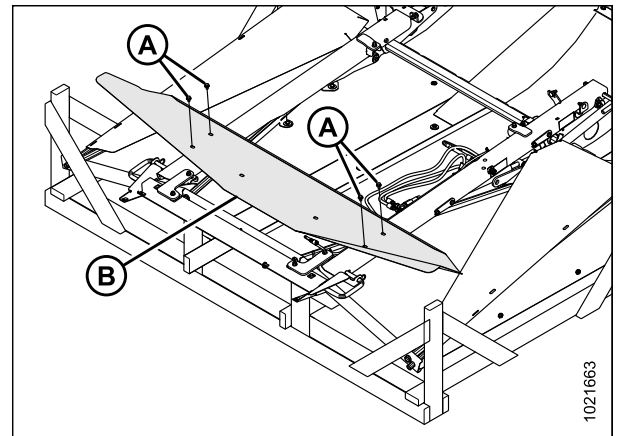

Figure 2.2: Removing Front Deflector

ASSEMBLY INSTRUCTIONS

3. Remove four bolts and nuts (A) and remove two bar clamps (B) from front pivot support (C).

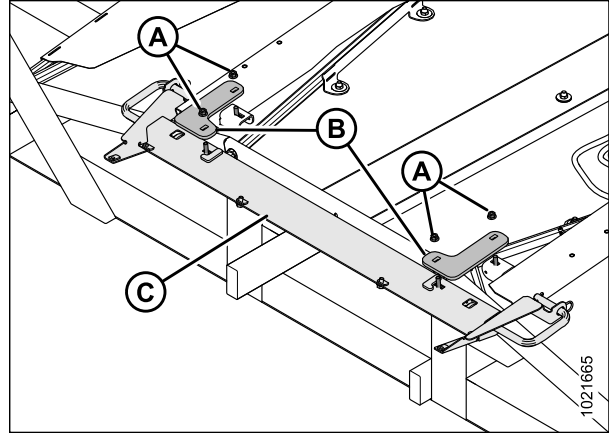

Figure 2.3: Removing Front Pivot Support

4. On both sides of the front pivot support (A), remove bolts and nuts (B) securing support (A) to the left and right supports.
5. Remove hairpins (C) from pivot pins (D). Slide pivot pins outward to disengage from side supports, and then remove front pivot support (A).

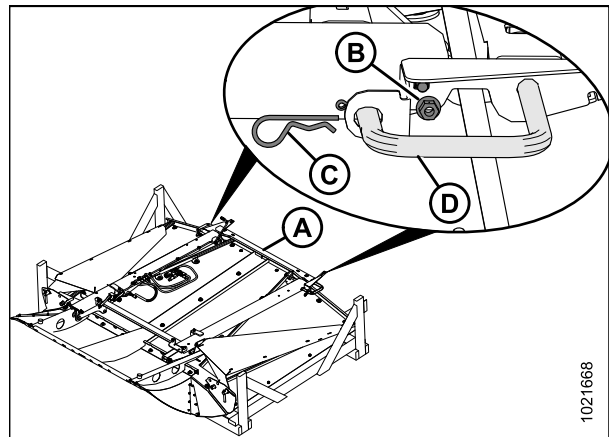

Figure 2.4: Removing Front Pivot Support

6. Remove nut and bolt (A) and remove pivot pin (B) from the left support.

NOTE:

If necessary, loosen handle (C) and adjust deflector so pin (B) can be removed.

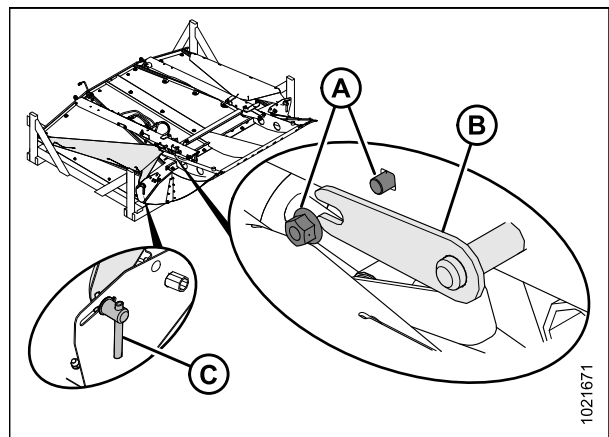

Figure 2.5: Removing Left Support

ASSEMBLY INSTRUCTIONS

7. Remove lynch pin (A) and washer (B) from pivot pin (C) through rod end of cylinder.

NOTE:

If necessary, lift left support (E) out of frame so pin (C) can slide out.

8. Release latch (D) and remove left support (E) complete with cylinder and hydraulic hoses.

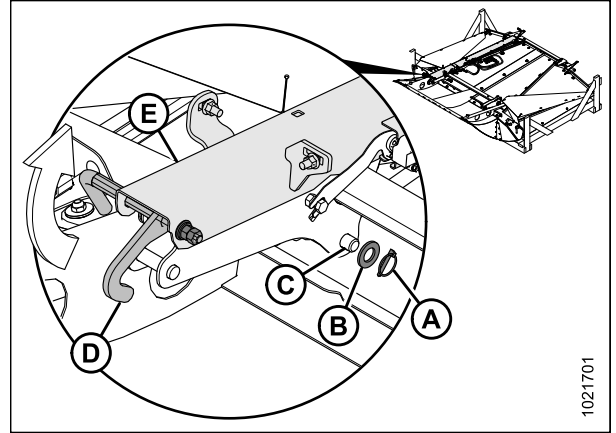

Figure 2.6: Removing Left Support

9. Remove nut and bolt (A) and remove pivot pin (B) from right support.

NOTE:

If necessary, loosen handle (C) and adjust deflector so pin (B) can be removed.

10. Remove the right support (D).

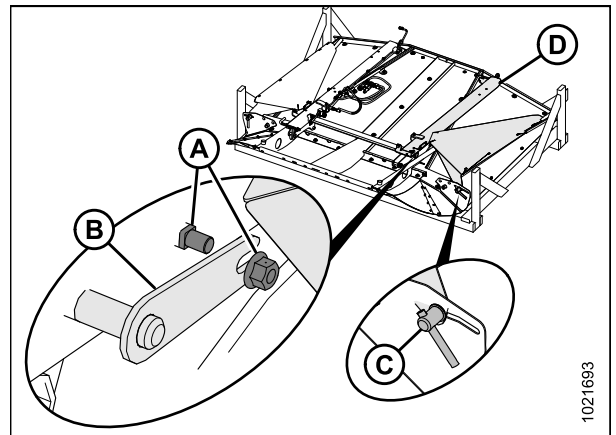

Figure 2.7: Removing Right Support

11. Remove rock shaft (A).
12. Remove four lag screws (B) securing swath forming shield to shipping crate. Discard lag screws and washers.

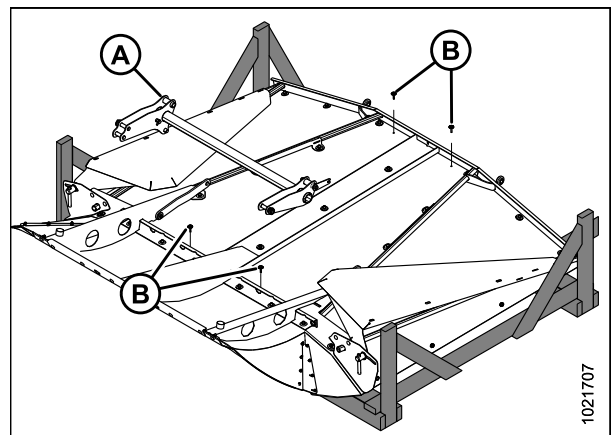

Figure 2.8: Removing Rock Shaft and Shipping Screws

ASSEMBLY INSTRUCTIONS

14. Position forklift with forks over front of forming shield, and attach lifting straps (A) through front and back of forming shield frame.
15. Lift forming shield out of shipping crate and set it down on a flat surface at assembly area.



Figure 2.9: Lifting Forming Shield with Forklift

2.2 Installing Swath Compressor on M1 Series Windrower

Follow these steps in order to install the swath compressor onto an M1 Series Windrower. The swath compressor weighs approximately 180 kg (400 lb.); two installers are required for this installation.

DANGER

To avoid bodily injury or death from unexpected start-up or fall of raised machine, stop engine, remove key and engage safety pin before going under machine for any reason.

NOTE:

Throughout this installation procedure, bolts and nuts should be made snug, but still allow for adjustment and alignment. All fasteners should be tightened to recommended torque specification in Step 16, page 19.

1. Loosely attach bar clamps (A) to each side of front support with two M10 bolts and nuts (B).

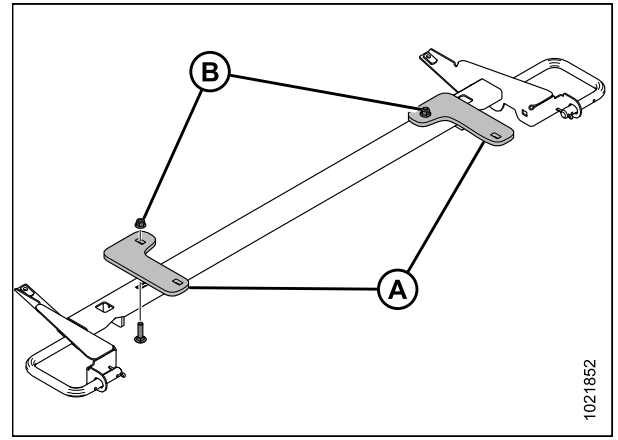

Figure 2.10: Front Support

2. Position front support (A) below the windrower frame at the cab end. Snug two bolts (B) on bar clamps (C) to hold front support in place, but do not tighten.

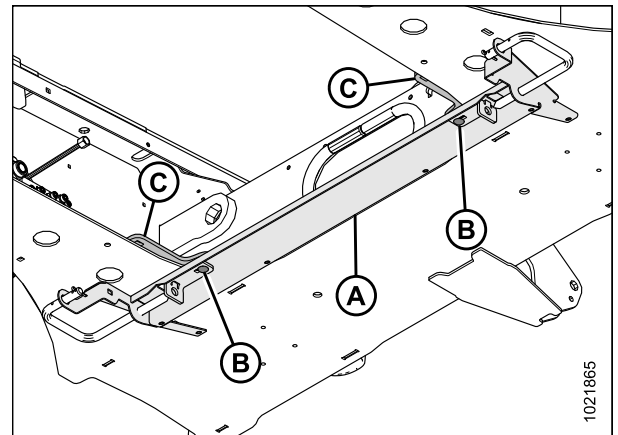

Figure 2.11: Front Support on Windrower Frame

ASSEMBLY INSTRUCTIONS

3. Install front end of left support (A) to the left side of windrower frame with 35 mm M10 bolt (B) and nut through bar clamp and 20 mm M10 bolt (C) through front support (D). Snug bolts.

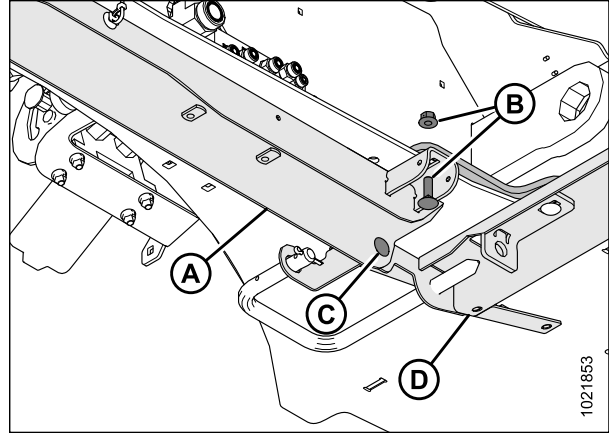

Figure 2.12: Left Support (Front)

4. Retrieve one washer (MD #30635) from manual bag and insert washer between rear of left support and windrower frame at location (A).
5. Secure rear of left support with 35 mm M10 bolts and nuts (B) and (C) through windrower frame.

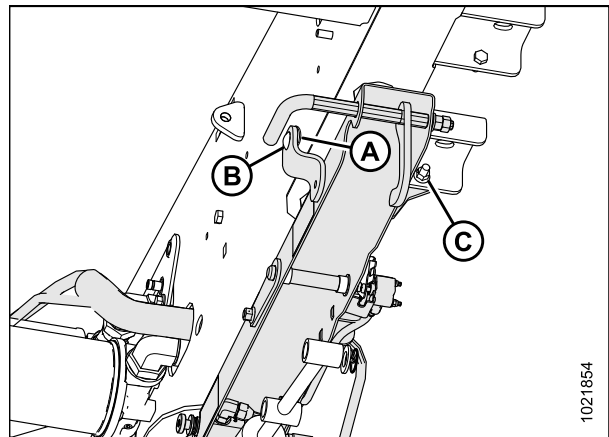

Figure 2.13: Left Support (Rear)

6. Using one 35 mm M10 bolt and nut (A), secure left support to windrower frame with bar clamp (B). Snug bolts on left support.

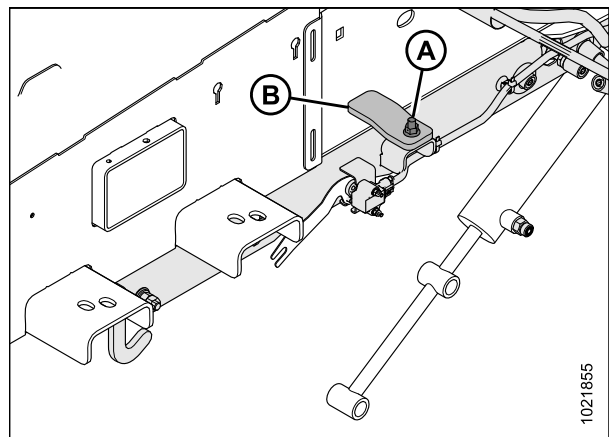

Figure 2.14: Left Support (Rear)

ASSEMBLY INSTRUCTIONS

7. Install front end of right support (A) to the right side of windrower frame with 35 mm M10 bolt and nut (B) through bar clamp (C) and 20 mm M10 bolt and nut (D) through front support. Snug bolts.

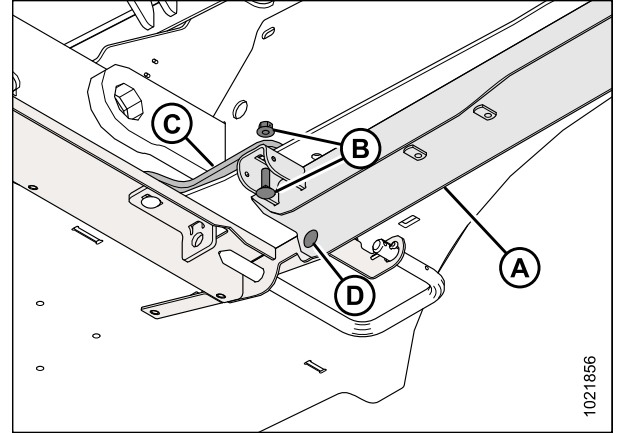

Figure 2.15: Right Support (Front)

8. Remove bolt and nut (A) securing air cleaner support (B) to windrower frame (C). Discard bolt and nut.

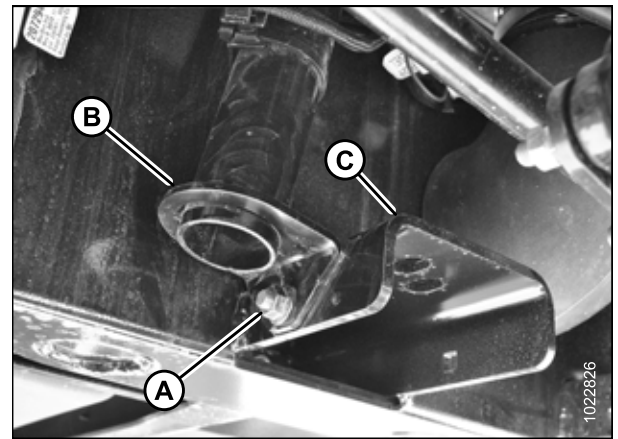

Figure 2.16: Right Support (Rear)

9. Position air cleaner support (A) between windrower frame and right rear support (B).
10. Install one 35 mm M10 bolt and nut (C) through windrower frame.
11. Using one 35 mm M10 bolt and nut (D), secure rear of right support (B) to inside of windrower frame with bar clamp (E).

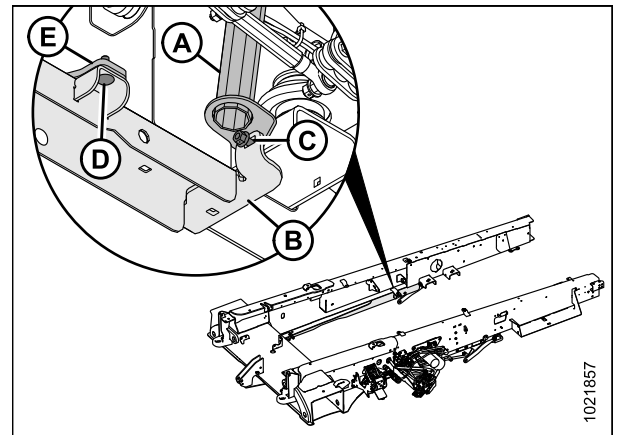

Figure 2.17: Right Support (Rear)

ASSEMBLY INSTRUCTIONS

12. Retrieve second washer (MD #30635) from the manual bag and insert washer between frame and rear of right support at location (A).
13. Secure support (A) and washer to frame with one 35 mm M10 bolt and nut (B). Snug bolts on right support.

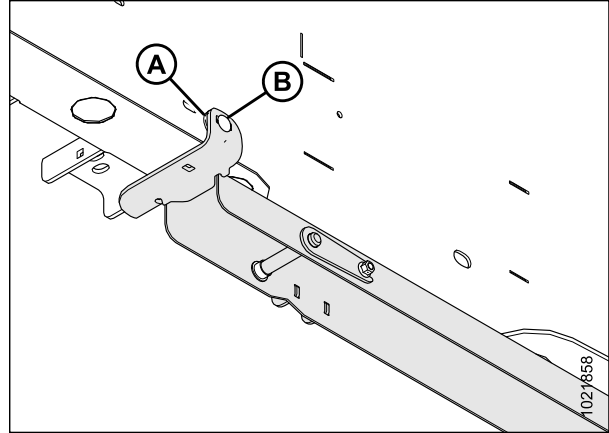

Figure 2.18: Right Support (Rear)

14. Position rock shaft lift (A) inside left and right support channels. Insert pivot pins (B) on both sides, and secure them with 20 mm M10 bolts and nuts (C).

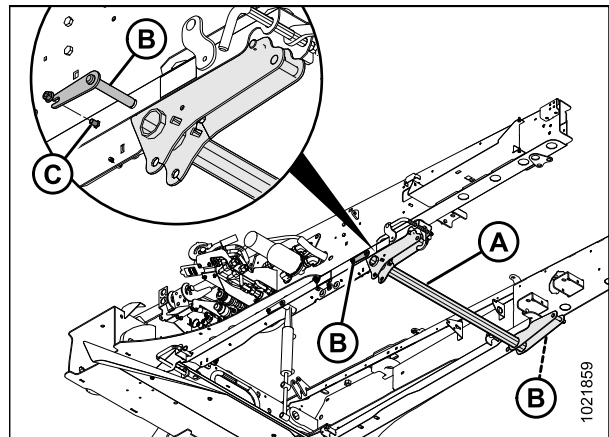

Figure 2.19: Rock Shaft Lift

15. Ensure sensor arm (A) engages bolt (B) on left rock shaft lift support, and ensure it is not bent or damaged.

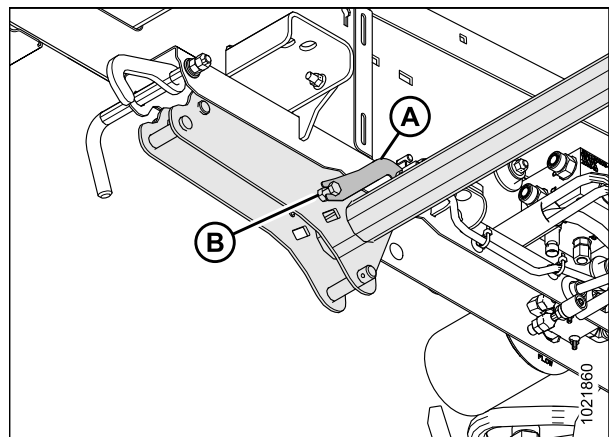

Figure 2.20: Sensor on Left Support

ASSEMBLY INSTRUCTIONS

16. Ensure front clamps (A) engage windrower frame as much as possible and torque all 14 bolts (B) that hold the swath compressor supports onto the windrower frame. Refer to [5.1 Torque Specifications, page 49](#).

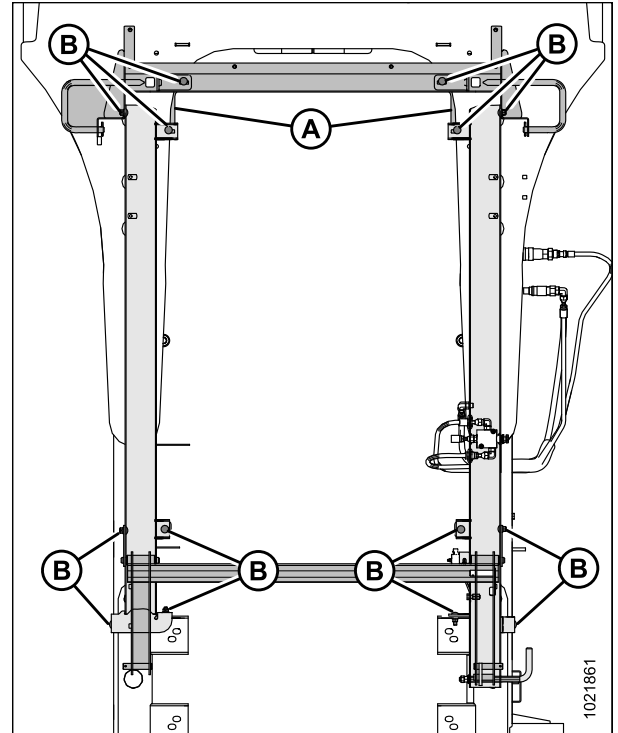

Figure 2.21: View from below Windrower

17. Locate three-pin electrical connector P729 above the front cross member of the windrower frame, on the left side (A).

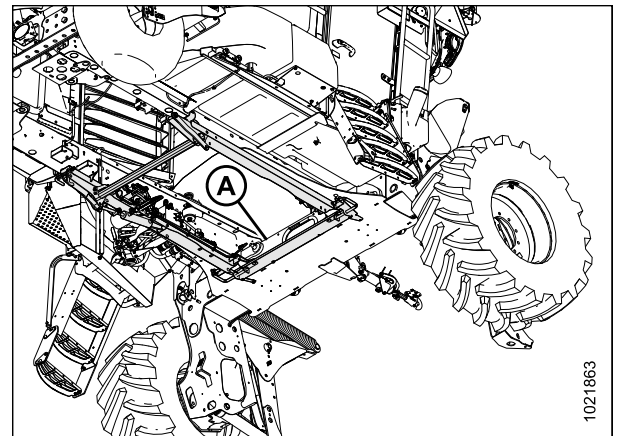

Figure 2.22: Windrower Electrical Harness

ASSEMBLY INSTRUCTIONS

18. Cut cable tie (A) securing P729 (B) to the larger electrical harness, and connect swath compressor connector to harness P729. Secure loose harness to frame with cable tie.

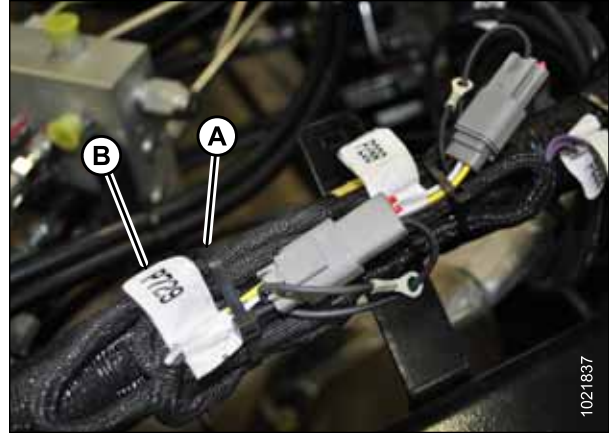

Figure 2.23: Windrower Electrical Harness

19. Prevent contact between the windrower's fuel filter sensor wire (A) and the swath forming shield frame. Use cable tie (MD #21763) from the manual bag to secure sensor wire.

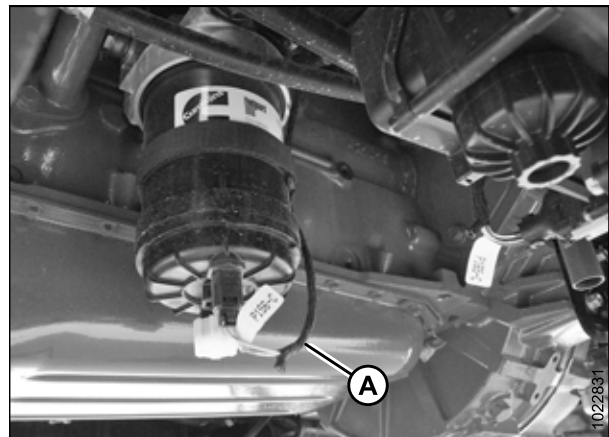

Figure 2.24: Fuel Filter Sensor Wire

M1240 hydraulic hose routing

21. Route three hydraulic hoses (A) through opening on left windrower frame.

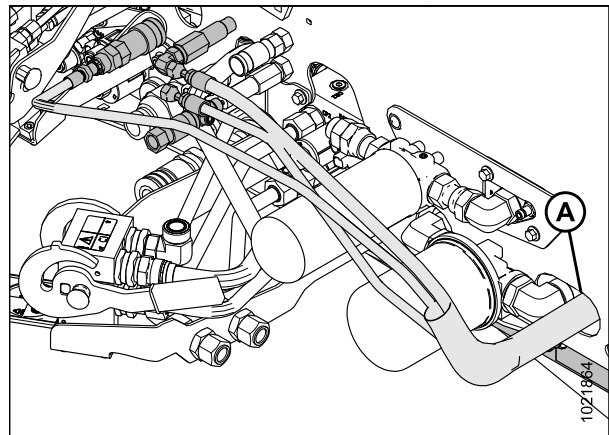

Figure 2.25: Hydraulic Connections

ASSEMBLY INSTRUCTIONS

M1170 hydraulic hose routing (2017 and earlier)

22. Route three hydraulic hoses (A) under windrower frame, and between the forming shield's support (B) and hydraulic cylinder.

NOTE:

Position hoses to avoid pinching.

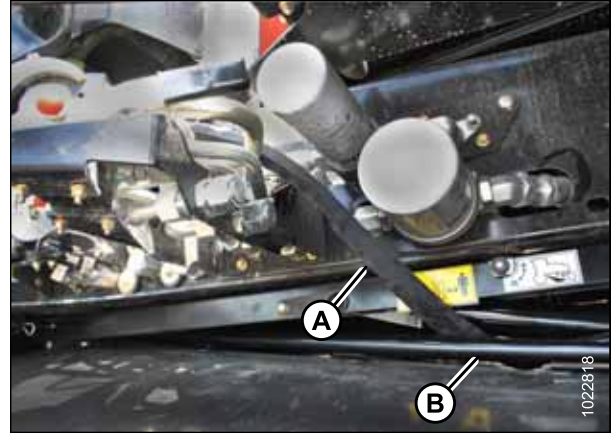

Figure 2.26: Hydraulic Connections

CAUTION

Check to be sure all bystanders have cleared the area.

23. Pressure buildup behind hydraulic couplers can make connections difficult. To relieve pressure, start the engine and press the SWATH COMPRESSOR LOWER button (A) for five seconds.
24. Shut off engine and remove key.



Figure 2.27: Windrower Console Buttons

25. The swath compressor has three hydraulic couplers; one male and two female. Route hoses under the filters and connect hydraulic couplers to the windrower as follows:

- Connect hose with male coupler to female connector (A)
- Connect hose with (smaller) female coupler to male connector (B) below
- Connect case drain with (larger) female coupler to the case drain connector (C)

26. Position hose sheath (D) so sheath contacts rear edge of coupler fittings. Secure sheath at both ends with two cable ties (MD #30753) supplied in manual bag.

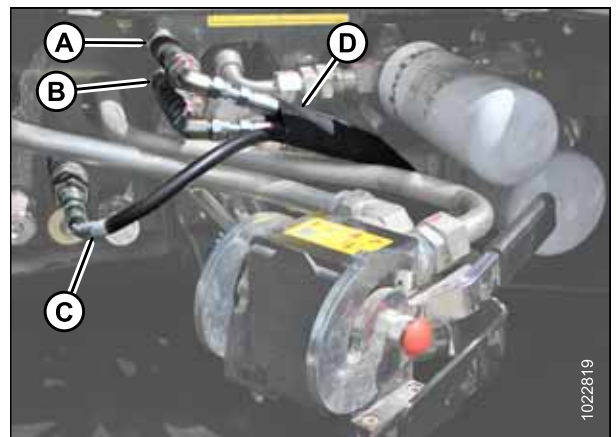

Figure 2.28: Hydraulic Connections

CAUTION

Check to be sure all bystanders have cleared the area.

ASSEMBLY INSTRUCTIONS

27. Start engine and carefully position the windrower over the swath compressor forming shield (A).

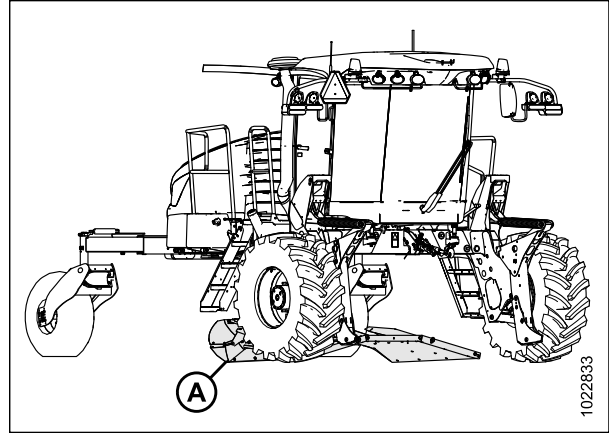

Figure 2.29: Forming Shield under Windrower

28. Press the SWATH COMPRESSOR LOWER button (A) to retract the rod end of swath compressor cylinder fully.
29. Shut off engine and remove key.



Figure 2.30: Windrower Console Buttons

30. Loosen handle (A) and remove three bolts and nuts (B) from side deflector shield (C). Retain bolts and nuts.

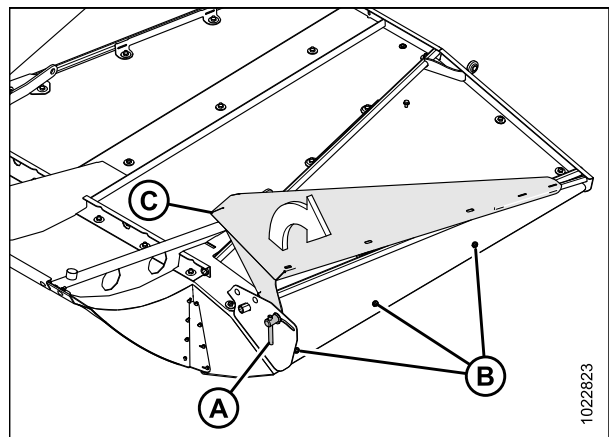

Figure 2.31: Side Deflector Shield Shipping Position

ASSEMBLY INSTRUCTIONS

31. Rotate side deflector shield (A) to working position, and secure it to forming shield with three bolts and nuts (B) from previous step.
32. Install bolts with heads facing the crop and torque nuts to 22 Nm (15 lbf·ft).
33. Position the side deflector shield and tighten the adjustment handle (C). Repeat on opposite side.

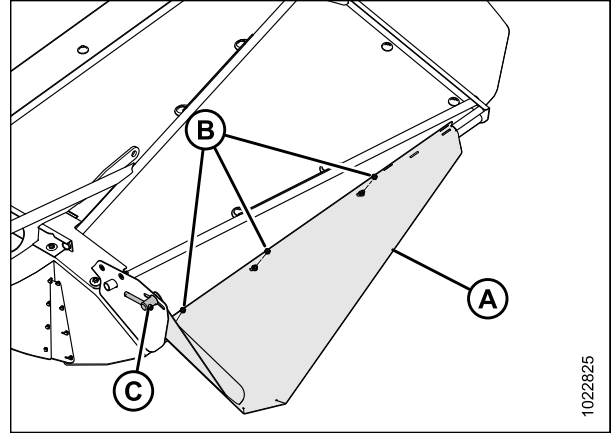

Figure 2.32: Side Deflector Shield Working Position

34. To make connecting lowering arms easier, turn lock handle (A) to lower rock shaft (B).

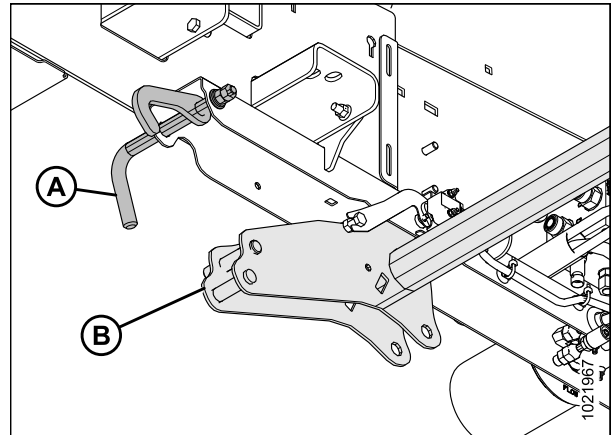

Figure 2.33: Rock Shaft and Lock

ASSEMBLY INSTRUCTIONS

35. Ensure bushings (A) are installed onto pins (B) on both sides of rock shaft.
36. Have two installers lift right rear corner of the swath forming shield (C), and engage lowering arm (D) to pin (B).
37. Secure lowering arms to pins with washers (E) and lynch pins (F). Repeat on opposite side.

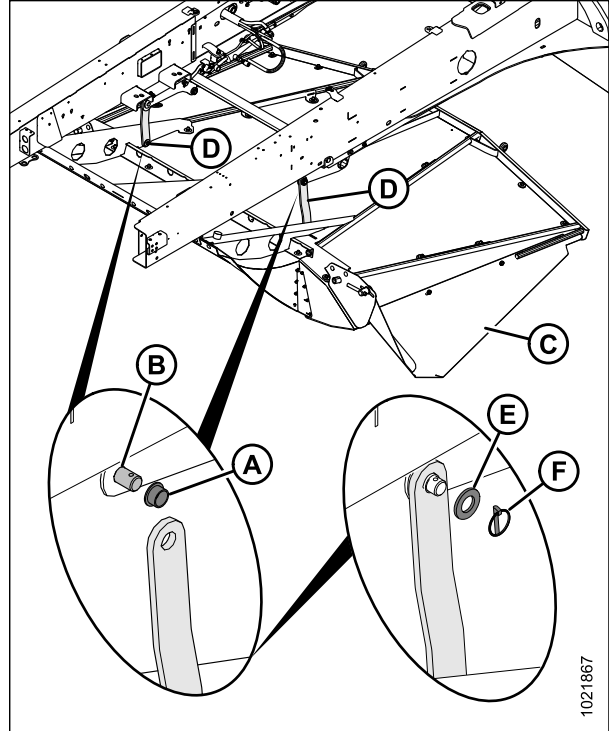

Figure 2.34: Attaching Lowering Arms

38. Have one installer push down on rear of swath forming shield (A) while a second installer lifts the front, and insert pins (B) through ball joints (C) at the front of the swath forming shield.

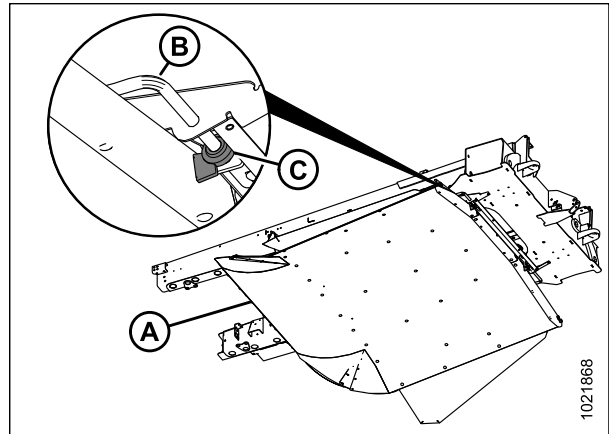

Figure 2.35: Connecting Front Pivot Pins

ASSEMBLY INSTRUCTIONS

39. Install hairpin (A) to secure pivot pin (B). Repeat on opposite side.

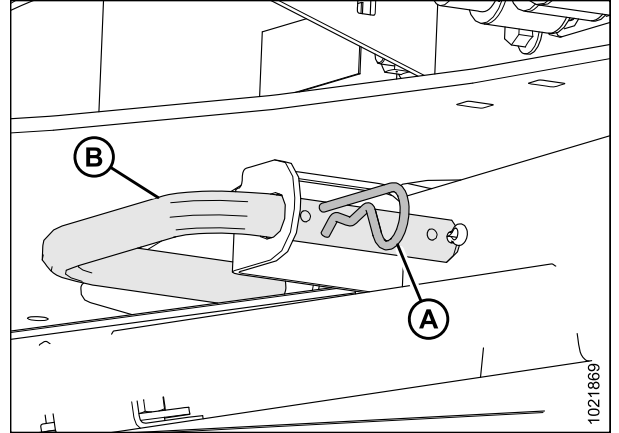

Figure 2.36: Connecting Front Pivot Pins

40. Connect rod end of hydraulic cylinder (A) to hole in the left side of rock shaft with pin (B). Ensure plate on pin engages slot in rock shaft support.
41. Secure pin with washer (C) and lynch pin (D).

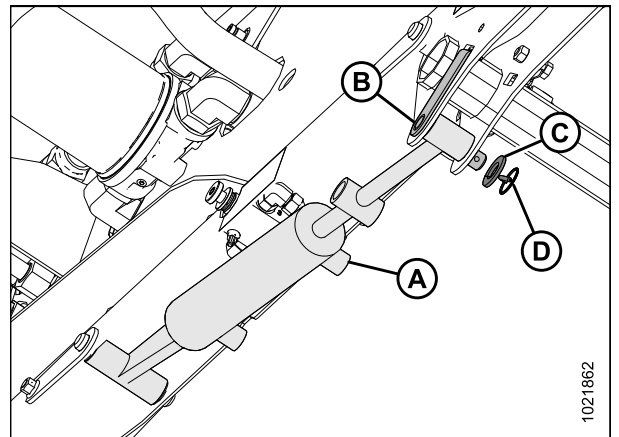

Figure 2.37: Connecting Cylinder

42. Install front deflector (A). Secure to front support with six M10 hex head bolts (B).

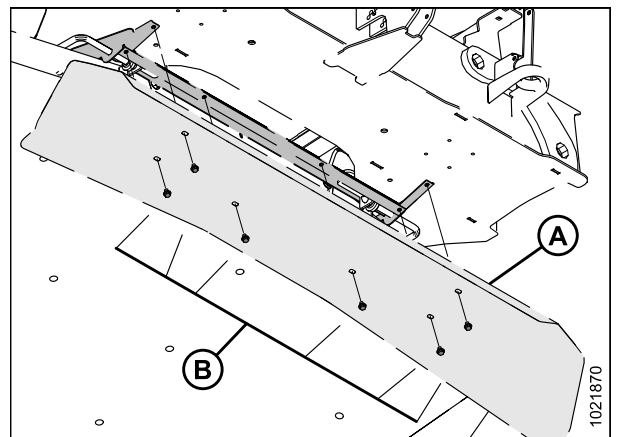

Figure 2.38: Front Deflector

3 Operation

3.1 Activating the Swath Compressor

The first time you connect a swath compressor to a windrower it must be activated in the windrower's control system. To activate the swath compressor with the Harvest Performance Tracker (HPT), follow these steps.

If necessary, refer to the windrower operator's manual to review navigating the HPT display.

1. Scroll down and select the HEADER SETUP menu (A).



Figure 3.1: Header Setup Page

2. Select the correct header size and type from the HEADER list.



Figure 3.2: Header Setup Page

OPERATION

3. Select ATTACHMENTS (A) from the HEADER SETUP page.

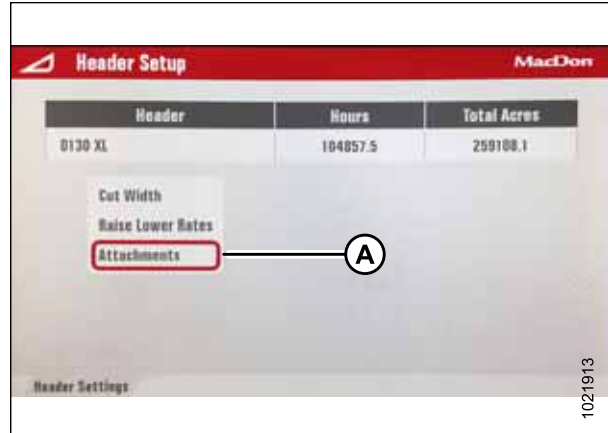

Figure 3.3: Header Setup Page

4. Select SWATH COMPRESSOR (A) from the menu. The sensor is now active, and the HPT will control the swath compressor.

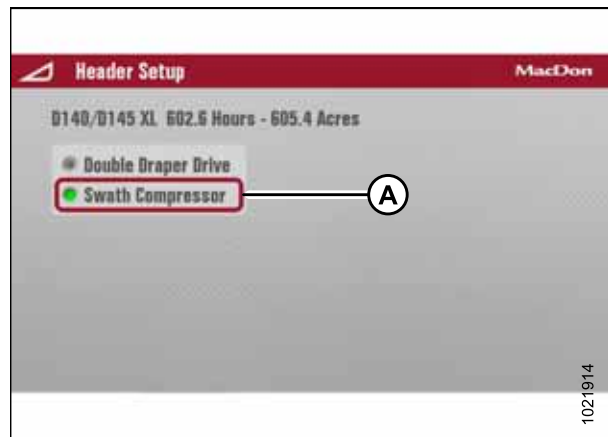

Figure 3.4: Attachments Page

3.2 Operating the Swath Compressor

The following topic explains how the windrower controls the swath compressor, and describes the automated raise/lower functions.

CAUTION

To avoid bodily injury or death from unexpected startup of machine, always stop engine and remove key from ignition before leaving operator's seat for any reason.

1. Before lowering the swath compressor, rotate handle (A) to disengage lock on the rear, left support.

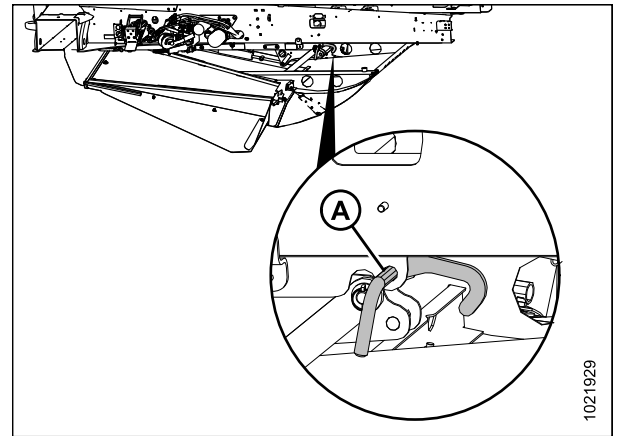

Figure 3.5: Swath Compressor Lock

Swath compressor height (A) is displayed on the Harvest Performance Tracker (HPT) with a scale from 0–10.



Figure 3.6: HPT Display

OPERATION

- Raise the swath compressor by pressing button (A) or lower it by pressing button (B) on the operator's console. Interrupt movement by letting go of the button.

NOTE:

Each momentary press of the button will increase/decrease the value by 1. Pressing and holding will change the value by 1 increment per second.



Figure 3.7: Operator's Console

NOTE:

The system remembers the last position set with the console buttons; this position becomes the target height. When an adjustment is made, the display shows the target value. The system immediately adjusts to attain the target position. After the last adjustment, the display shows target value for 5 seconds then reverts to the actual position.

Display functions

- When swath compressor is moving, the target value (A) will update in real time, the windrower image (B) will appear as wireframe, and the swath compressor (C) will flash.
- When target height is achieved, windrower icon (B) turns solid.
- When swath compressor is fully raised, the position value (A) will show zero and the windrower image (B) will be wireframe.
- If no header is attached, icon (B) is **NOT** displayed and automation is disabled. Swath compressor height can still be adjusted.



Figure 3.8: HPT Display

Swath compressor automated functions: header engaged

- When a ground speed faster than 2.5 km/h (1.6 mph) is detected, the swath compressor lowers to target height.
- When ground speed transitions through 1.6 km/h (1 mph) during deceleration, the swath compressor is fully raised.
- When ground speed is faster than 1.6 km/h (1 mph) and the HEADER ENGAGE switch is toggled from ON to OFF, the swath compressor is fully raised.
- When operator's seat is in engine forward, the GSL is out of PARK, and the displayed height indicates 1 or more, an IMPORTANT message instructing you to raise swath compressor appears on the HPT accompanied by a tone.

When the swath compressor is not in use, or when the windrower is in engine forward mode, engage the swath compressor lock. Refer to [3.2.5 Operating the Swath Compressor Lock, page 34](#).

3.2.1 Setting up the Swath Compressor

The following settings are suggested as a starting point for first-time users of the swath compressor attachment.

CAUTION

To avoid bodily injury or death from unexpected startup of machine, always stop engine and remove key from ignition before leaving operator's seat for any reason.

1. Before lowering the swath compressor, rotate handle (A) to disengage lock on the rear, left support.

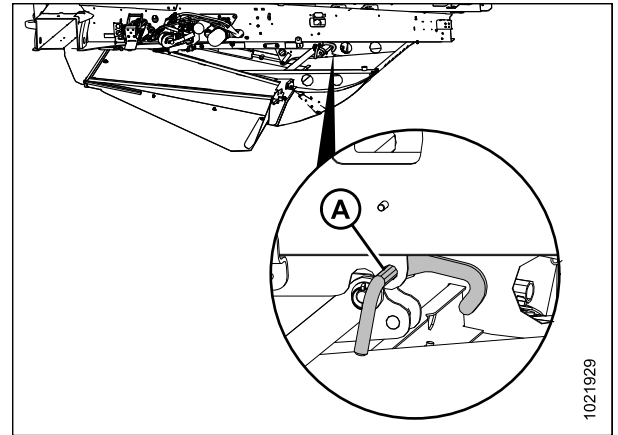

Figure 3.9: Swath Compressor Lock

2. Start the engine, set ground speed lever (GSL) in Park, and ensure that header is disengaged.
3. Using controls (A) and (B) on the console, lower the swath compressor to the target (preferred) operating height. Set to 6 if no preferred setting.
4. Engage and then disengage the header. The swath compressor will raise fully.
5. Engage header and begin cutting crop. When ground speed exceeds 2.5 km/h (1.6 mph), the swath compressor will lower to the target (preferred) height.
6. Stop the windrower and check the formation of the windrow.
 - If necessary adjust the target height. Refer to Step 2, page 30.
 - If the edges of the windrow are not sufficiently pressed into the stubble, adjust side deflectors. Refer to 3.2.4 Adjusting Side Deflectors, page 33.
 - If swath compressor forming shield raises too easily when travelling over dense windrows, adjust down force pressure. Refer to 3.2.3 Adjusting Down Force, page 32.
7. When the swath compressor is not in use, is being serviced, or when the windrower is in engine forward mode, raise the swath compressor and engage the



Figure 3.10: Operator's Console

OPERATION

swath compressor lock. Refer to [3.2.5 Operating the Swath Compressor Lock](#), page 34.

3.2.2 Programming One-Touch-Return

The One-Touch-Return buttons A, B, and C always save header height settings, but swath compressor settings can also be saved depending on the header type.

1. To program the One-Touch-Return buttons, adjust header and swath compressor to desired position then press and hold button A, B, or C on the ground speed lever (GSL) handle for 3 seconds until an audible tone is heard. The current header/swath compressor settings are saved to that button. To return header to a preset condition, tap the A, B, or C button quickly.

NOTE:

A new swath compressor setting will only be stored if the compressor position was set with the UP/DOWN buttons on the console. If swath compressor height sensor is disabled, automation is disabled. Raise/lower operation is only possible by pressing console buttons.



Figure 3.11: Ground Speed Lever (GSL)

3.2.3 Adjusting Down Force

The swath compressor is designed to raise up when the force of the crop exceeds the down force pressure setting. When the force from the crop decreases, the compressor deck will automatically return to the target height. This helps the swath compressor avoid damage if it encounters an obstacle. The swath compressor is factory set for the least amount of down force; follow these steps to adjust the amount of down force.

OPERATION

1. The down force adjustment knob is locked in place with a jam nut (A). Loosen jam nut enough to allow the adjustment knob (B) to turn. Do NOT remove nut.
 - If the swath compressor down force is too light (not enough compression/not anchored to stubble), turn adjuster knob (B) to the right (clockwise) in 1/2 turn increments.
 - If the swath compressor down force is too heavy (too much compression/crop shelling), turn the adjuster knob (B) to the left (counterclockwise) in 1/2 turn increments.

NOTE:

Start with down force set to lightest position (all the way counterclockwise) and add down force as needed in 1/2 turn increments.

2. When adjustment is complete, tighten jam nut finger tight (A).

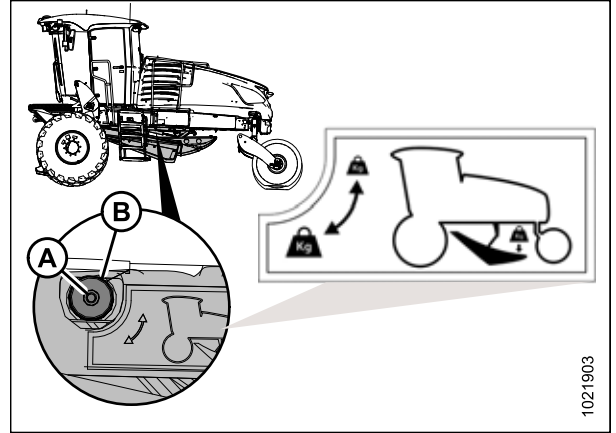

Figure 3.12: Down Force Adjustment Knob

3.2.4 Adjusting Side Deflectors

To reduce wind damage to the windrow, adjust side deflectors to ensure edges are tucked in and anchored to the stubble.

1. To adjust swath compressor side deflectors (A), loosen handles (B) and raise or lower side deflectors to the desired position. To ensure windrow placement is centered, adjust both side deflectors to the same position.
2. Tighten handles (B) when adjustment is complete.

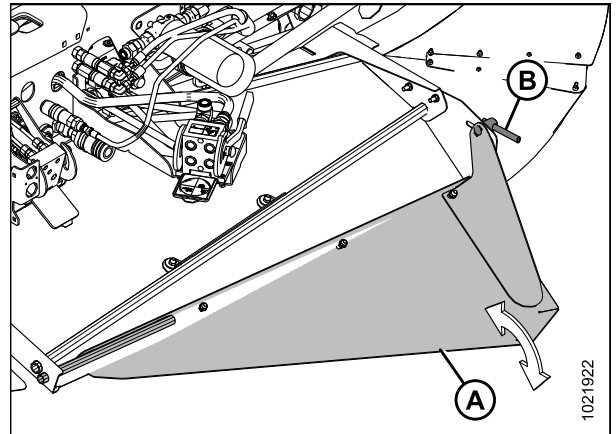

Figure 3.13: Swath Compressor Side Deflectors

OPERATION

3.2.5 Operating the Swath Compressor Lock

The swath compressor lock is located on the left side-channel of the swath compressor frame. When engaged, the lock prevents the forming shield from lowering.

Turn lock handle (A) clockwise to engage the swath compressor lock under the following conditions:

- The swath compressor is not in use
- The windrower is being serviced
- The windrower is in engine forward mode

Turn handle (A) counterclockwise to disengage the lock before operating the swath compressor.

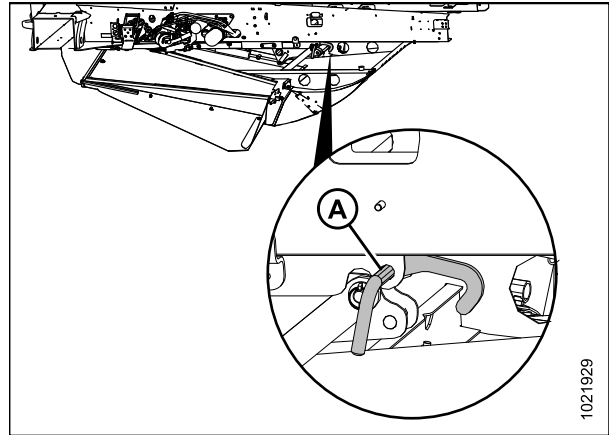

Figure 3.14: Swath Compressor Lock

3.3 Removing the Swath Forming Shield

Windrower service or maintenance procedures may require access under the machine. Do **NOT** service the windrower by lowering the swath compressor and sitting on top of the forming shield. To remove the swath forming shield follow these steps:

⚠ CAUTION

To avoid bodily injury or death from unexpected startup of machine, always stop engine and remove key from ignition before leaving operator's seat for any reason.

NOTE:

The swath forming shield is large and heavy; two installers are required for this procedure.

1. Lower the swath compressor all the way, turn off the windrower, and remove the key.
2. At the front of the swath compressor assembly, remove hairpin (A) from pivot pin (B) on both sides of the frame.

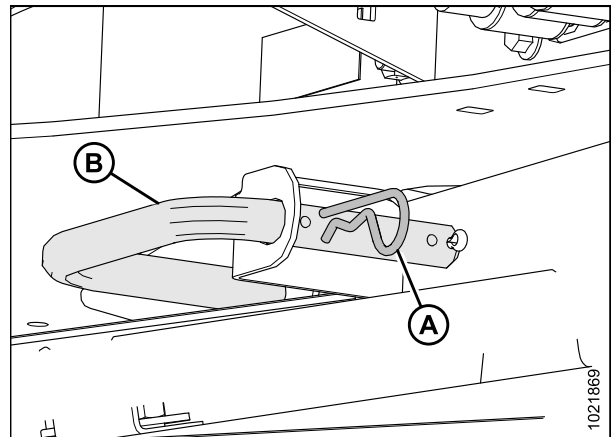

Figure 3.15: Removing Hairpins: Front

3. To release the front side of swath forming shield (A), support shield and pull pivot pins (B) out from ball joints (C) on both sides of frame. To avoid misplaced parts, reinstall hairpins into pivot pins.

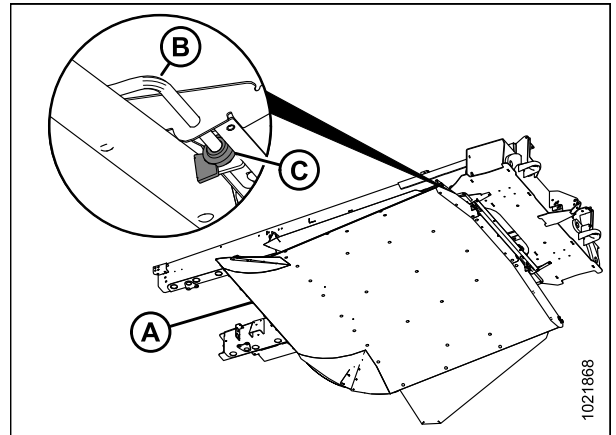

Figure 3.16: Removing Pivot Pins: Front

OPERATION

4. To release rear side of swath forming shield, have one installer support shield (C) while another installer disconnects lowering arms (D) from pins (B) on both sides of frame by removing lynch pins (F) and washers (E).
5. On both sides of frame, store bushings (A), washers (E) and lynch pins (F) on pins (B).

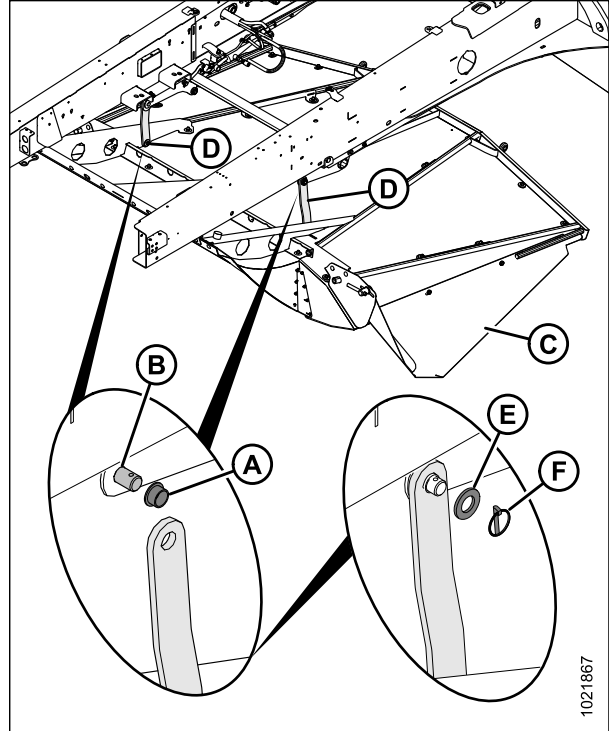

Figure 3.17: Disconnecting Lowering Arms

4 Parts

This section lists all the replacement parts that can be ordered for the Swath Compressor for M1 Series Windrowers.

When ordering, provide the complete and proper part number.

PARTS

4.1 Swath Compressor Frame – Parts List

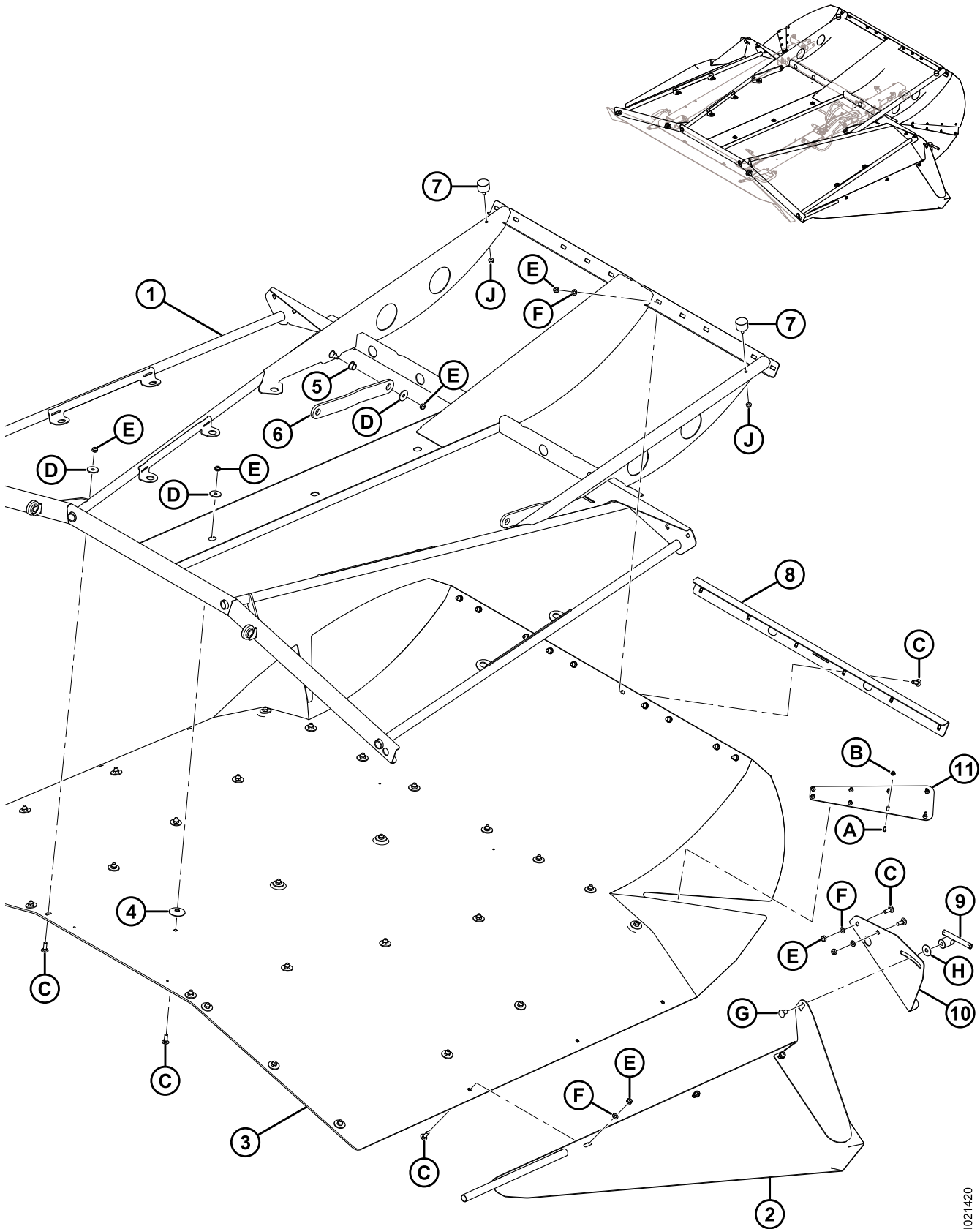

PARTS

Ref	Part Number	Description	Qty	Serial Number
1	277318	SUPPORT – DEFLECTORS, WELD'T	1	
2	277410	DEFLECTOR – LH WELD'T	1	
	277411	DEFLECTOR – RH WELD'T	1	
3	277323	SHEET – SWATH COMPRESSOR	1	
4	128697	DISC – RETAINER	21	
5	128737	BUSHING – FLANGE	2	
6	128729	ARM – LOWER	2	
7	203350	BUMPER – RUBBER	2	
8	128740	ANGLE – REAR TOP	1	
9	247693	ASSEMBLY – HANDLE	2	
10	277405	SUPPORT – REAR DEFLECTOR	1	
	277414	SUPPORT – REAR DEFLECTOR, RH	1	
11	277409	STRAP – JOINING	2	

PARTS

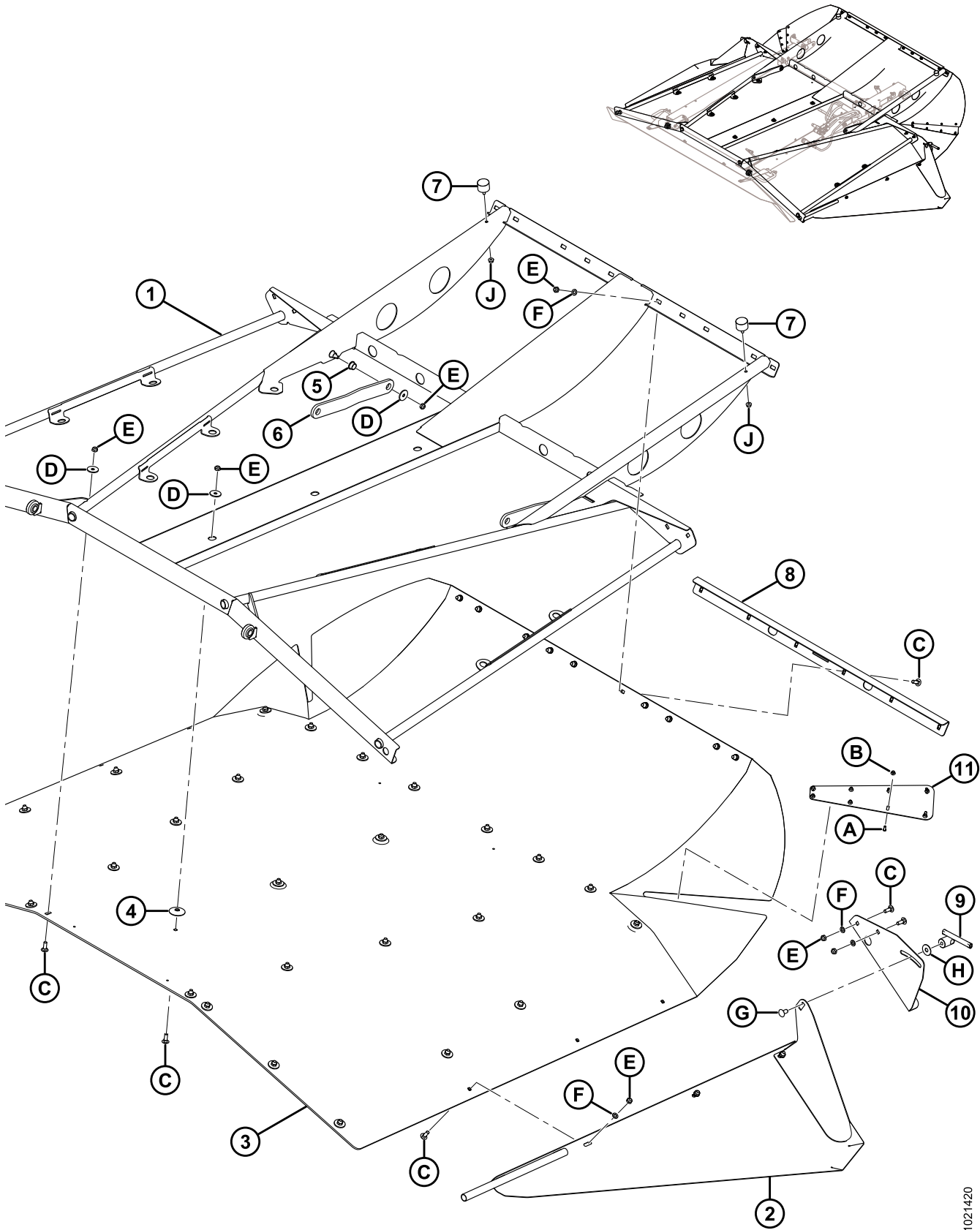

1021420

PARTS

Ref	Part Number	Description	Qty	Serial Number
A	191393	BOLT – HEX SOC M6X1X20-12.9-AB0R	16	
B	152668	NUT – HEX FLG CTR LOC M6X1-8-A2L	16	
C	184662	BOLT – RHSN TFL M10X1.5X30-8.8-A3L	49	
D	16652	WASHER – FLAT	31	
E	184692	NUT – HEX NYLOC M10X1.5-8-A3L	51	
F	184711	WASHER – FLAT REG M10-200HV-A3L	20	
G	152439	BOLT – RHSSN M12X1.75X25-8.8-A3L	2	
H	32247	WASHER – FLAT	2	
J	135337	NUT – HEX FLG CTR LOC M8X1.25-8-A2L	2	

PARTS

4.2 Swath Compressor Hydraulics and Supports – Parts List

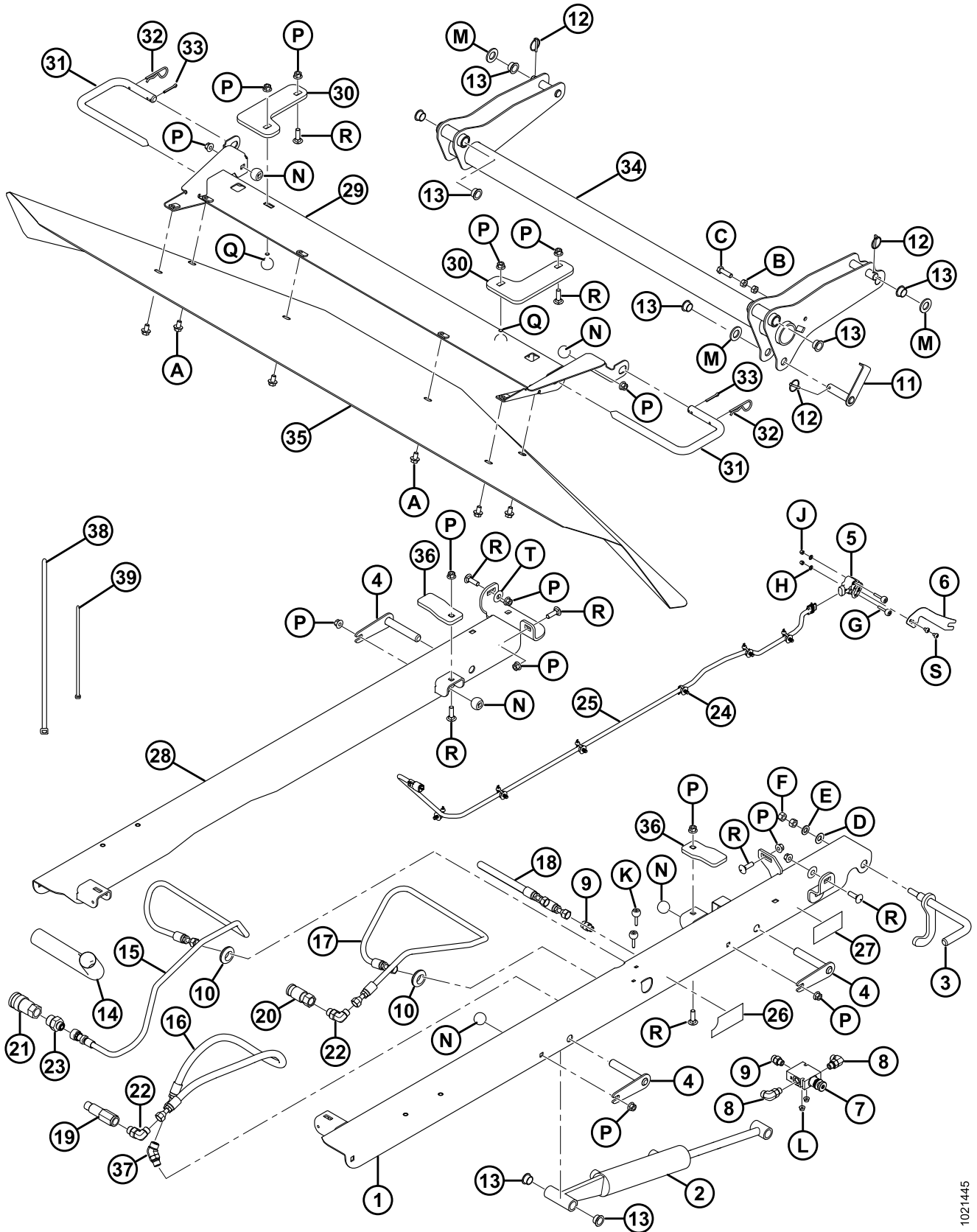

PARTS

Ref	Part Number	Description	Qty	Serial Number
1	128780	SUPPORT – LH WELD'T	1	
2	128764	CYLINDER	1	
3	128768	LEVER – LOCK PIN WELD'T	1	
4	128788	PIN – PIVOT, WELD'T	3	
5	128994	ROTARY SENSOR HV	1	
6	128773	ARM – SENSOR	1	
7	128789	VALVE – PRESSURE REDUCING	1	
8	136095	FITTING – ELBOW 90° HYD	2	
9	135778	FITTING – ADAPTER	2	
10	42046	GROMMET	2	
11	277331	PIN – CYLINDER, WELD'T	1	
12	50193	PIN – LYNCH	3	
13	128737	BUSHING – FLANGE	10	
14	112940	SLEEVE	1	
15	277042	HOSE – HYD	1	
16	277041	HOSE – HYD	1	
17	277044	HOSE – HYD	1	
18	232597	HOSE – HYD	1	
19	135386	COUPLER – MALE HYD. 3/8 IN. FLAT FACE	1	
20	135312	COUPLER – FEMALE HYD. 3/8 IN. FLAT FACE	1	
21	135474	COUPLER – HYDRAULIC, 1/2 IN FEMALE FF	1	
22	136149	FITTING – ELBOW 90° HYD CW O-RING	2	
23	136194	FITTING – ADAPTER	1	
24	136655	FASTENER – FIR TREE MT W/ TIE	6	
25	209256	HARNESS – SWATH COMPRESSOR	1	
26	128973	DECAL – DOWN FORCE	1	
27	128974	DECAL – UP LOCK	1	
28	128781	SUPPORT – RH WELD'T	1	
29	128762	SUPPORT – FRONT PIVOT, WELD'T	1	

PARTS

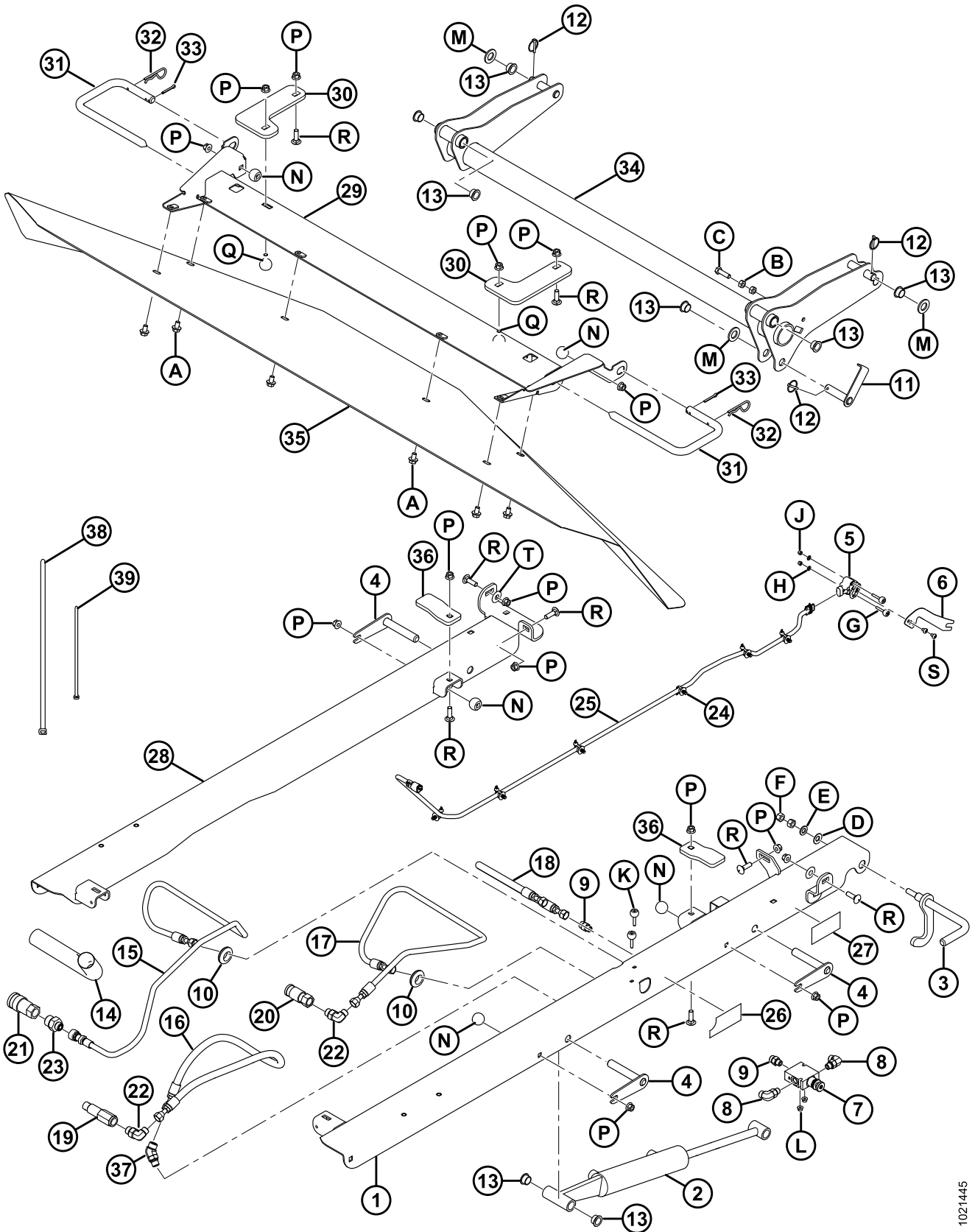

1021445

PARTS

Ref	Part Number	Description	Qty	Serial Number
30	128776	BAR – CLAMP	2	
31	128756	PIN – PIVOT	2	
32	13125	PIN – HAIR	2	
33	18648	PIN – COTTER 3/16 DIA X 1.25 ZP	2	
34	128770	ROCKSHAFT – LIFT, WELD'T	1	
35	128699	DEFLECTOR – FRONT	1	
36	277435	BAR – CLAMP	2	
37	136144	FITTING – ELBOW 45° HYD	1	
38	30753 ¹	FASTENER – CABLE TIE BLACK	2	
39	21763 ¹	FASTENER – CABLE TIE BLACK	1	
A	136151	BOLT – HEX FLG HD TFL M10X1.5X16-8.8-A3L	6	
B	30505	NUT – HEX M10X1.5-10-A3L	2	
C	30628	BOLT – HEX HD M10X1.5X35-8.8-A3L	1	
D	184595	WASHER – CONICAL SPRING 1/2"	1	
E	184714	WASHER – FLAT REG M12-300HV-A3L	1	
F	184694	NUT – HEX M12X1.75-8-A3L	2	
G	136604	BOLT – RHSN TFL M5X0.8X40-8.8-AA2L	2	
H	18798	WASHER – FLAT SAE 7/32 ID X 7/16 IN OD ZP	2	
J	197230	NUT – HEX NYLOC M5X0.8-8-A2L	2	
K	136731	BOLT – RHSN M6X1X45-8.8-A2L	2	
L	152668	NUT – HEX FLG CTR LOC M6X1-8-A2L	2	
M	18601	WASHER – SAE FLAT 13/16 ID X 1.5 IN OD ZP	3	
N	136178	BOLT – RHSN M10X1.5X20-8.8-A3L	4	
P	135799	NUT – HEX FLG CTR LOC M10X1.5-10-A3L	12	
Q	152732	BOLT – RHSN M10X1.5X40-8.8-A3L	2	
R	135691	BOLT – RHSN TFL M10X1.5X35-8.8-A3L	8	
S	252291	SCR – PAN HD M6X1X8-8.8-A2L	2	
T	30635 ¹	WASHER – FLAT REG M10-STL-SOFT-AA1J	2	

1. Shipped in manual bag.

PARTS

4.3 Decals

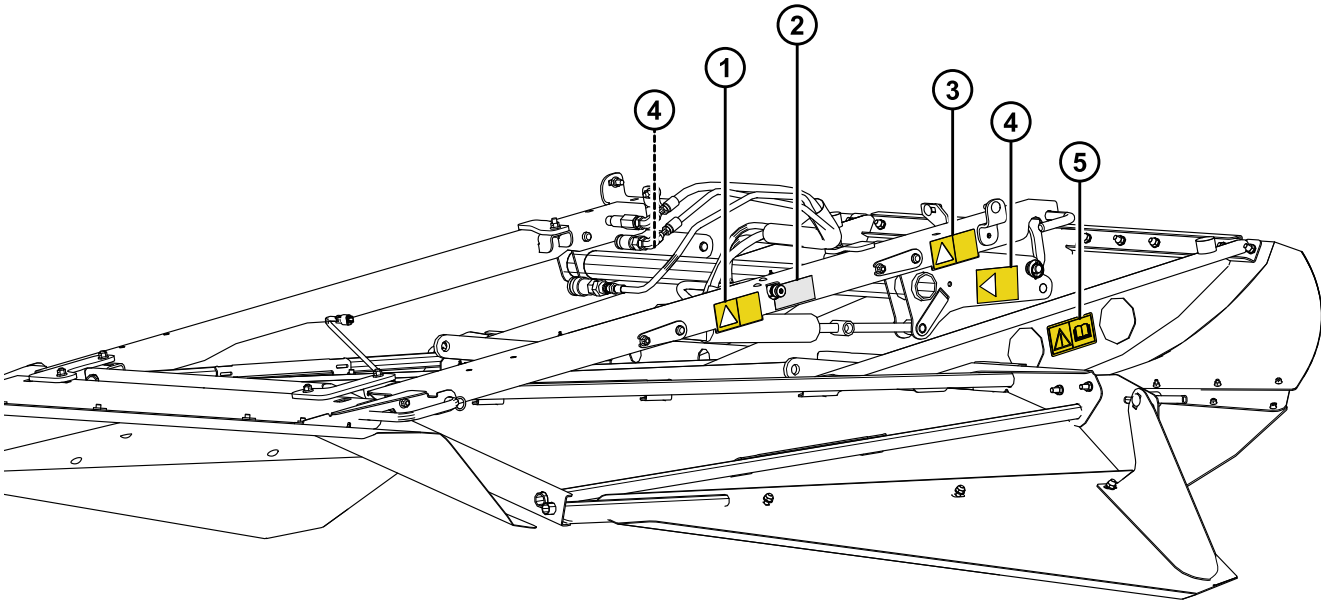

1



2



3



4 x2

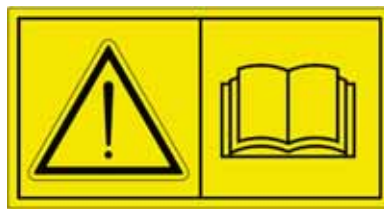

5

1022127

PARTS

Ref	Part Number	Description	Qty	Serial Number
1	166466	DECAL – HIGH PRESSURE FLUID	1	
2	128973	DECAL – DOWN FORCE	1	
3	291638	DECAL – DECK LOWER LOCK (may not be exactly as shown)	1	
4	174683	DECAL – PINCH POINT	2	
5	184372	DECAL – READ MANUAL	1	

5 Reference

5.1 Torque Specifications

The following tables provide correct torque values for various bolts, cap screws, and hydraulic fittings.

- Tighten all bolts to torque values specified in charts (unless otherwise noted throughout this manual).
- Replace hardware with same strength and grade of bolt.
- Use torque value tables as a guide and periodically check tightness of bolts.
- Understand torque categories for bolts and cap screws by using their identifying head markings.

Jam nuts

When applying torque to finished jam nuts, multiply the torque applied to regular nuts by $f=0.65$.

Self-tapping screws

Standard torque is to be used (not to be used on critical or structurally important joints).

5.1.1 Metric Bolt Specifications

Table 5.1 Metric Class 8.8 Bolts and Class 9 Free Spinning Nut

Nominal Size (A)	Torque (Nm)		Torque (lbf·ft) (*lbf·in)	
	Min.	Max.	Min.	Max.
3-0.5	1.4	1.6	*13	*14
3.5-0.6	2.2	2.5	*20	*22
4-0.7	3.3	3.7	*29	*32
5-0.8	6.7	7.4	*59	*66
6-1.0	11.4	12.6	*101	*112
8-1.25	28	30	20	23
10-1.5	55	60	40	45
12-1.75	95	105	70	78
14-2.0	152	168	113	124
16-2.0	236	261	175	193
20-2.5	460	509	341	377
24-3.0	796	879	589	651

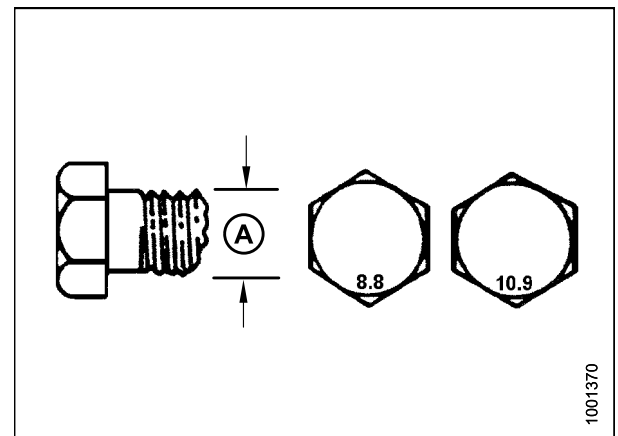

Figure 5.1: Bolt Grades

REFERENCE

Table 5.2 Metric Class 8.8 Bolts and Class 9 Distorted Thread Nut

Nominal Size (A)	Torque (Nm)		Torque (lbf-ft) (*lbf-in)	
	Min.	Max.	Min.	Max.
3-0.5	1	1.1	*9	*10
3.5-0.6	1.5	1.7	*14	*15
4-0.7	2.3	2.5	*20	*22
5-0.8	4.5	5	*40	*45
6-1.0	7.7	8.6	*69	*76
8-1.25	18.8	20.8	*167	*185
10-1.5	37	41	28	30
12-1.75	65	72	48	53
14-2.0	104	115	77	85
16-2.0	161	178	119	132
20-2.5	314	347	233	257
24-3.0	543	600	402	444

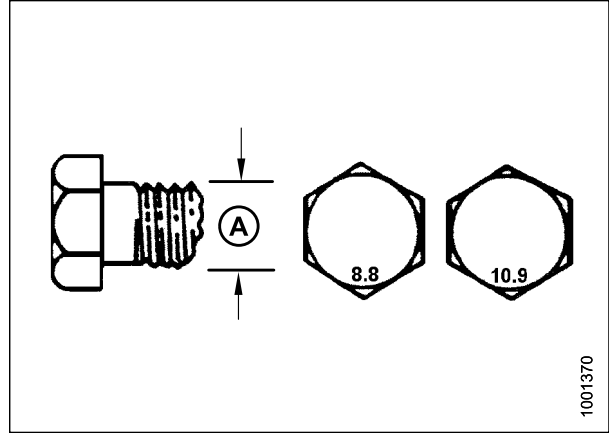

Figure 5.2: Bolt Grades

Table 5.3 Metric Class 10.9 Bolts and Class 10 Free Spinning Nut

Nominal Size (A)	Torque (Nm)		Torque (lbf-ft) (*lbf-in)	
	Min.	Max.	Min.	Max.
3-0.5	1.8	2	*18	*19
3.5-0.6	2.8	3.1	*27	*30
4-0.7	4.2	4.6	*41	*45
5-0.8	8.4	9.3	*82	*91
6-1.0	14.3	15.8	*140	*154
8-1.25	38	42	28	31
10-1.5	75	83	56	62
12-1.75	132	145	97	108
14-2.0	210	232	156	172
16-2.0	326	360	242	267
20-2.5	637	704	472	521
24-3.0	1101	1217	815	901

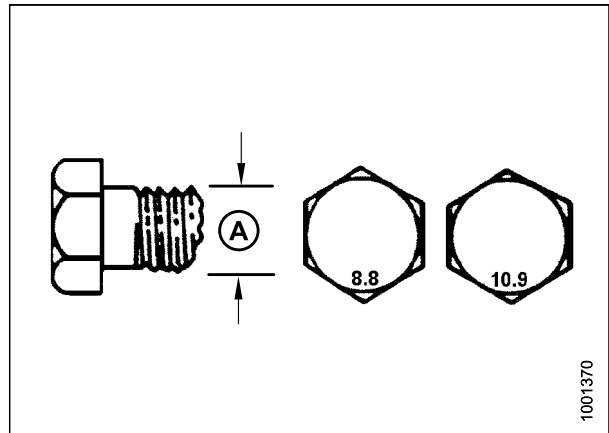

Figure 5.3: Bolt Grades

REFERENCE

Table 5.4 Metric Class 10.9 Bolts and Class 10 Distorted Thread Nut

Nominal Size (A)	Torque (Nm)		Torque (lbf-ft) (*lbf-in)	
	Min.	Max.	Min.	Max.
3-0.5	1.3	1.5	*12	*13
3.5-0.6	2.1	2.3	*19	*21
4-0.7	3.1	3.4	*28	*31
5-0.8	6.3	7	*56	*62
6-1.0	10.7	11.8	*95	*105
8-1.25	26	29	19	21
10-1.5	51	57	38	42
12-1.75	90	99	66	73
14-2.0	143	158	106	117
16-2.0	222	246	165	182
20-2.5	434	480	322	356
24-3.0	750	829	556	614

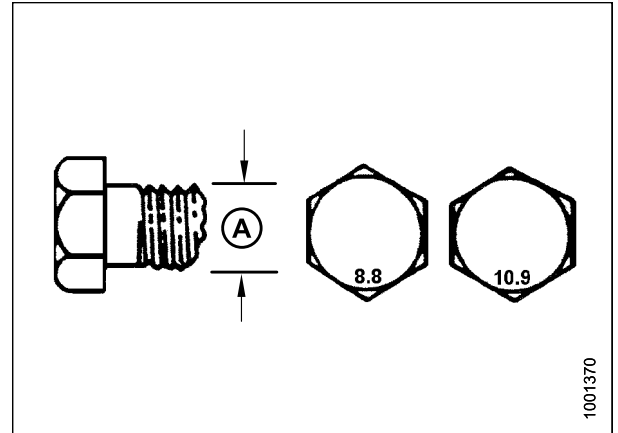

Figure 5.4: Bolt Grades

5.1.2 Metric Bolt Specifications Bolting into Cast Aluminum

Table 5.5 Metric Bolt Bolting into Cast Aluminum

Nominal Size (A)	Bolt Torque			
	8.8 (Cast Aluminum)		10.9 (Cast Aluminum)	
	Nm	lbf-ft	Nm	lbf-ft
M3	–	–	–	1
M4	–	–	4	2.6
M5	–	–	8	5.5
M6	9	6	12	9
M8	20	14	28	20
M10	40	28	55	40
M12	70	52	100	73
M14	–	–	–	–
M16	–	–	–	–

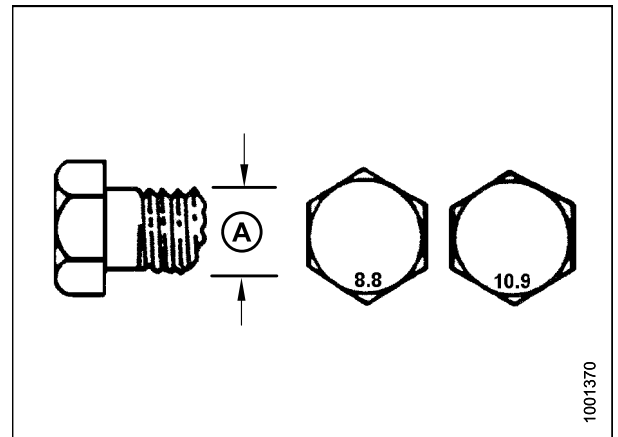

Figure 5.5: Bolt Grades

REFERENCE

5.1.3 O-Ring Boss (ORB) Hydraulic Fittings (Adjustable)

1. Inspect O-ring (A) and seat (B) for dirt or obvious defects.
2. Back off lock nut (C) as far as possible. Ensure that washer (D) is loose and is pushed toward lock nut (C) as far as possible.
3. Check that O-ring (A) is **NOT** on threads and adjust if necessary.
4. Apply hydraulic system oil to O-ring (A).

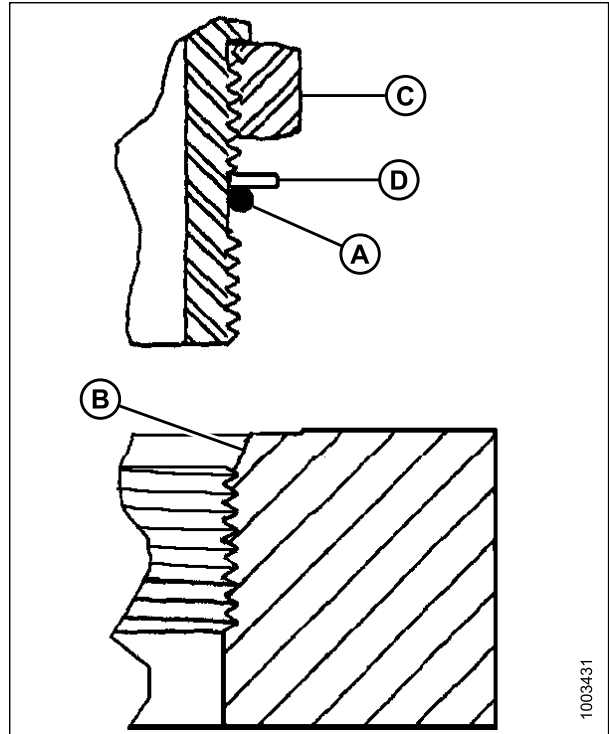

Figure 5.6: Hydraulic Fitting

5. Install fitting (B) into port until back up washer (D) and O-ring (A) contact part face (E).
6. Position angle fittings by unscrewing no more than one turn.
7. Turn lock nut (C) down to washer (D) and tighten to torque shown. Use two wrenches, one on fitting (B) and other on lock nut (C).
8. Check final condition of fitting.

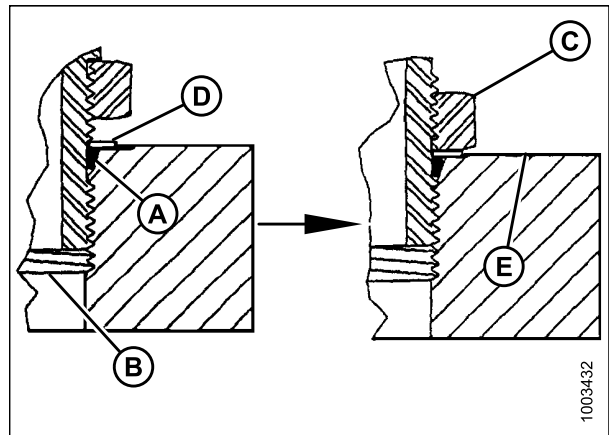

Figure 5.7: Hydraulic Fitting

REFERENCE

Table 5.6 O-Ring Boss (ORB) Hydraulic Fittings (Adjustable)

SAE Dash Size	Thread Size (in.)	Torque Value ²	
		Nm	lbf·ft (*lbf·in)
-2	5/16-24	6-7	*53-62
-3	3/8-24	12-13	*106-115
-4	7/16-20	19-21	14-15
-5	1/2-20	21-33	15-24
-6	9/16-18	26-29	19-21
-8	3/4-16	46-50	34-37
-10	7/8-14	75-82	55-60
-12	1-1/16-12	120-132	88-97
-14	1-3/8-12	153-168	113-124
-16	1-5/16-12	176-193	130-142
-20	1-5/8-12	221-243	163-179
-24	1-7/8-12	270-298	199-220
-32	2-1/2-12	332-365	245-269

2. Torque values shown are based on lubricated connections as in reassembly.

REFERENCE

5.1.4 O-Ring Boss (ORB) Hydraulic Fittings (Non-Adjustable)

1. Inspect O-ring (A) and seat (B) for dirt or obvious defects.
2. Check that O-ring (A) is **NOT** on threads and adjust if necessary.
3. Apply hydraulic system oil to O-ring.
4. Install fitting (C) into port until fitting is hand-tight.
5. Torque fitting (C) according to values in Table 5.7, page 54.
6. Check final condition of fitting.

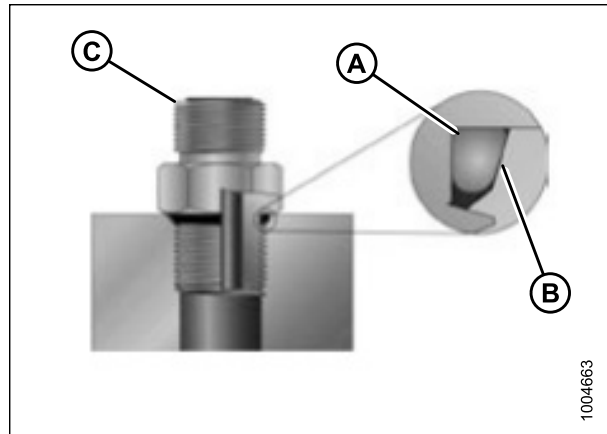

Figure 5.8: Hydraulic Fitting

Table 5.7 O-Ring Boss (ORB) Hydraulic Fittings (Non-Adjustable)

SAE Dash Size	Thread Size (in.)	Torque Value ³	
		Nm	lbf·ft (*lbf·in)
-2	5/16–24	6–7	*53–62
-3	3/8–24	12–13	*106–115
-4	7/16–20	19–21	14–15
-5	1/2–20	21–33	15–24
-6	9/16–18	26–29	19–21
-8	3/4–16	46–50	34–37
-10	7/8–14	75–82	55–60
-12	1-1/16–12	120–132	88–97
-14	1-3/8–12	153–168	113–124
-16	1-5/16–12	176–193	130–142
-20	1-5/8–12	221–243	163–179
-24	1-7/8–12	270–298	199–220
-32	2-1/2–12	332–365	245–269

3. Torque values shown are based on lubricated connections as in reassembly.

REFERENCE

5.1.5 O-Ring Face Seal (ORFS) Hydraulic Fittings

1. Check components to ensure that sealing surfaces and fitting threads are free of burrs, nicks, scratches, or any foreign material.



Figure 5.9: Hydraulic Fitting

2. Apply hydraulic system oil to O-ring (B).
3. Align tube or hose assembly so that flat face of sleeve (A) or (C) comes in full contact with O-ring (B).
4. Thread tube or hose nut (D) until hand-tight. The nut should turn freely until it is bottomed out.
5. Torque fittings according to values in Table 5.8, page 55.

NOTE:

If applicable, hold hex on fitting body (E) to prevent rotation of fitting body and hose when tightening fitting nut (D).

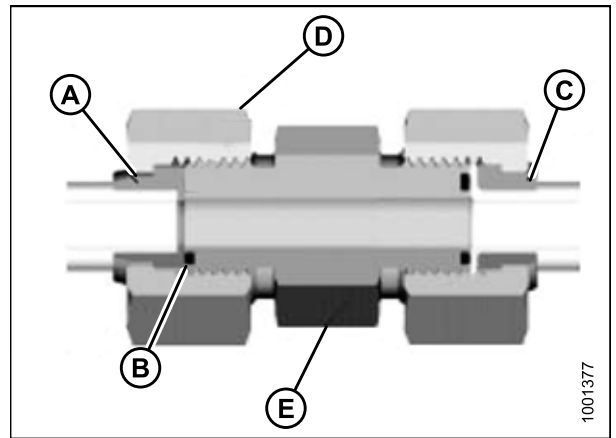

Figure 5.10: Hydraulic Fitting

6. Use three wrenches when assembling unions or joining two hoses together.
7. Check final condition of fitting.

Table 5.8 O-Ring Face Seal (ORFS) Hydraulic Fittings

SAE Dash Size	Thread Size (in.)	Tube O.D. (in.)	Torque Value ⁴	
			Nm	lbf-ft
-3	Note ⁵	3/16	–	–
-4	9/16	1/4	25–28	18–21
-5	Note ⁵	5/16	–	–
-6	11/16	3/8	40–44	29–32
-8	13/16	1/2	55–61	41–45
-10	1	5/8	80–88	59–65
-12	1-3/16	3/4	115–127	85–94

4. Torque values and angles shown are based on lubricated connection as in reassembly.
5. O-ring face seal type end not defined for this tube size.

REFERENCE

Table 5.8 O-Ring Face Seal (ORFS) Hydraulic Fittings (continued)

SAE Dash Size	Thread Size (in.)	Tube O.D. (in.)	Torque Value ⁶	
			Nm	lbf-ft
-14	Note ⁵	7/8	–	–
-16	1-7/16	1	150–165	111–122
-20	1-11/16	1-1/4	205–226	151–167
-24	1–2	1-1/2	315–347	232–256
-32	2-1/2	2	510–561	376–414

5.1.6 Tapered Pipe Thread Fittings

Assemble pipe fittings as follows:

1. Check components to ensure that fitting and port threads are free of burrs, nicks and scratches, or any form of contamination.
2. Apply pipe thread sealant (paste type) to external pipe threads.
3. Thread fitting into port until hand-tight.
4. Torque connector to appropriate torque angle. The Turns From Finger Tight (T.F.F.T.) values are shown in Table 5.9, page 56. Make sure that tube end of a shaped connector (typically 45° or 90°) is aligned to receive incoming tube or hose assembly. Always finish alignment of fitting in tightening direction. Never back off (loosen) pipe threaded connectors to achieve alignment.
5. Clean all residue and any excess thread conditioner with appropriate cleaner.
6. Assess final condition of fitting. Pay special attention to possibility of cracks to port opening.
7. Mark final position of fitting. If a fitting leaks, disassemble fitting and check for damage.

NOTE:

Overtorque failure of fittings may not be evident until fittings are disassembled.

Table 5.9 Hydraulic Fitting Pipe Thread

Tapered Pipe Thread Size	Recommended T.F.F.T.	Recommended F.F.F.T.
1/8–27	2–3	12–18
1/4–18	2–3	12–18
3/8–18	2–3	12–18
1/2–14	2–3	12–18
3/4–14	1.5–2.5	12–18
1–11 1/2	1.5–2.5	9–15
1 1/4–11 1/2	1.5–2.5	9–15
1 1/2–11 1/2	1.5–2.5	9–15
2–11 1/2	1.5–2.5	9–15

-
6. Torque values and angles shown are based on lubricated connection as in reassembly.

REFERENCE

5.2 Conversion Chart

Table 5.10 Conversion Chart

Quantity	SI Units (Metric)		Factor	Inch-Pound Units (Imperial)	
	Unit Name	Abbreviation		Unit Name	Abbreviation
Area	hectares	ha	$\times 2.4710 =$	acres	acres
Flow	liters per minute	L/min	$\times 0.2642 =$	US gallons per minute	gpm
Force	Newtons	N	$\times 0.2248 =$	pounds force	lbf
Length	millimeters	mm	$\times 0.0394 =$	inch	in.
Length	meters	m	$\times 3.2808 =$	foot	ft.
Power	kilowatts	kW	$\times 1.341 =$	horsepower	hp
Pressure	kilopascals	kPa	$\times 0.145 =$	pounds per square inch	psi
Pressure	megapascals	MPa	$\times 145.038 =$	pounds per square inch	psi
Pressure	bar (Non-SI)	bar	$\times 14.5038 =$	pounds per square inch	psi
Torque	Newton meters	Nm	$\times 0.7376 =$	pound feet or foot pounds	lbf-ft
Torque	Newton meters	Nm	$\times 8.8507 =$	pound inches or inch pounds	lbf-in
Temperature	degrees Celsius	°C	$(^{\circ}\text{C} \times 1.8) + 32 =$	degrees Fahrenheit	°F
Velocity	meters per minute	m/min	$\times 3.2808 =$	feet per minute	ft/min
Velocity	meters per second	m/s	$\times 3.2808 =$	feet per second	ft/s
Velocity	kilometers per hour	km/h	$\times 0.6214 =$	miles per hour	mph
Volume	liters	L	$\times 0.2642 =$	US gallons	US gal
Volume	milliliters	ml	$\times 0.0338 =$	ounces	oz.
Volume	cubic centimeters	cm ³ or cc	$\times 0.061 =$	cubic inches	in. ³
Weight	kilograms	kg	$\times 2.2046 =$	pounds	lb.

Predelivery Checklist

Perform these checks and adjustments prior to delivery to your Customer. The completed checklist should be retained by either the Operator or the Dealer.

CAUTION

Follow the instructions carefully. Pay attention to safety-related messages, and avoid unsafe practices.

✓	Item	Reference
	Check for shipping damage or missing parts. Be sure all shipping dunnage is removed.	—
	Check for loose hardware. Tighten to required torque.	<i>5.1 Torque Specifications, page 49</i>
	Raise and lower swath compressor to check for linkage binding. Rubber bumpers at rear should contact windrower frame when fully raised. If binding occurs, adjust by adding/removing washers (MD #30635) where rear supports are fastened to the outside of frame.	<ul style="list-style-type: none"> • Page 4, page 16 • Page 12, page 18
	Ensure sensor arm does not bind when raising or lowering the swath compressor.	<i>Page 15, page 18</i>
	Ensure fuel filter sensor wire does not contact swath compressor frame when fully raised.	<i>Page 19, page 20</i>
	Check hydraulic hose routing for clearance when raising or lowering swath compressor. Adjust as necessary.	<i>Page 20, page 20</i>
	Ensure hydraulic hose sheath is secured in place with cable ties.	<i>Page 26, page 21</i>
	Ensure swath compressor lock is functioning properly.	<i>3.2.5 Operating the Swath Compressor Lock, page 34</i>
	Check for hydraulic leaks.	—
	Ensure side deflectors are set evenly to desired position.	<i>3.2.4 Adjusting Side Deflectors, page 33</i>

Date checked: _____ Checked by: _____

Index

13125.....	45
16652.....	41
18601.....	45
18648.....	45
18798.....	45
21763.....	45
30505.....	45
30628.....	45
30635.....	45
30753.....	45
32247.....	41
42046.....	43
50193.....	43
112940.....	43
128697.....	39
128699.....	45
128729.....	39
128737.....	39, 43
128740.....	39
128756.....	45
128762.....	43
128764.....	43
128768.....	43
128770.....	45
128773.....	43
128776.....	45
128780.....	43
128781.....	43
128788.....	43
128789.....	43
128973.....	43
128974.....	43
128994.....	43
135312.....	43
135337.....	41
135386.....	43
135474.....	43
135691.....	45
135778.....	43
135799.....	45
136095.....	43
136144.....	45
136149.....	43
136151.....	45
136178.....	45
136194.....	43
136604.....	45
136655.....	43
136731.....	45
152439.....	41
152668.....	41, 45

152732.....	45
184595.....	45
184662.....	41
184692.....	41
184694.....	45
184711.....	41
184714.....	45
191393.....	41
197230.....	45
203350.....	39
209256.....	43
232597.....	43
247693.....	39
252291.....	45
277041.....	43
277042.....	43
277044.....	43
277318.....	39
277323.....	39
277331.....	43
277405.....	39
277409.....	39
277410.....	39
277411.....	39
277414.....	39
277435.....	45

A

adjustments	
down force.....	32
side deflectors	33

C

conversion charts	57
-------------------------	----

D

decals	
safety signs	9
down force	
adjusting	32

F

forming shield	
remove.....	35

INDEX

H

harvest performance tracker (HPT)	
activating.....	27
hydraulics	
fittings	
O-ring boss (ORB) adjustable	52
O-ring boss (ORB) non-adjustable	54
O-ring face seal (ORFS).....	55
tapered pipe thread fittings	56
hydraulic safety.....	6

I

installation	15
--------------------	----

M

maintenance safety	5
metric bolts	
torque specifications	49

O

one-touch-return	
programming	32
operation	
controls	29
down force.....	32
initial settings.....	31
one-touch-return	32
side deflectors	33

P

parts	
decals	46
frame	38
hydraulics and supports.....	42

S

safety	
alert symbols	1
general safety	3
hydraulic safety.....	6
maintenance and servicing	5
safety sign decals	8–9
installing decals	8
signal words	2
sensors	
activating.....	27

service	
removing forming shield.....	35
setup	
initial settings.....	31
installing.....	15
unpacking.....	11
side deflectors	
adjusting	33
specifications	
torque specifications	49

T

torque specifications.....	49
metric bolt specifications.....	49
bolting into cast aluminum	51
O-ring boss (ORB) hydraulic fittings (adjustable) .	52
O-ring boss (ORB) hydraulic fittings (non- adjustable).....	54
O-ring face seal (ORFS) fittings.....	55
tapered pipe thread fittings.....	56

MacDon Industries Ltd.

680 Moray Street
Winnipeg, Manitoba
Canada R3J 3S3
t. (204) 885-5590
f. (204) 832-7749

MacDon, Inc.

10708 N. Pomona Avenue
Kansas City, Missouri
United States 64153-1924
t. (816) 891-7313
f. (816) 891-7323

MacDon Australia Pty. Ltd.

A.C.N. 079 393 721
P.O. Box 243, Suite 3, 143 Main Street
Greensborough, Victoria, Australia 3088
t. 03 9432 9982
f. 03 9432 9972

MacDon Brasil Agribusiness Ltda.

Rua Grã Nicco, 113, sala 202, B. 02
Mossunguê, Curitiba, Paraná
CEP 81200-200 Brasil
t. +55 (41) 2101-1713
f. +55 (41) 2101-1699

LLC MacDon Russia Ltd.

123317 Moscow, Russia
10 Presnenskaya nab, Block C
Floor 5, Office No. 534, Regus Business Centre
t. +7 495 775 6971
f. +7 495 967 7600

CUSTOMERS

MacDon.com

DEALERS

Portal.MacDon.com

Trademarks of products are the marks of their respective manufacturers and/or distributors.

Printed in Canada