

R85
**Rotary Disc 16-Foot Self-Propelled
Windrower Header**

Unloading and Assembly Instructions

214016 Revision A
2017 Model Year
Original Instruction

R85 Rotary Disc 16-Foot Self-Propelled Windrower Header



1005291

Published: July 2016

Introduction

This instructional manual describes the unloading, setup, and predelivery requirements for MacDon Model R85 Rotary Disc 16-Foot Self-Propelled Windrower Headers.

Carefully read all the material provided before attempting to use or service the machine.

When setting up the machine or making adjustments, review and follow the recommended machine settings in all relevant MacDon publications. Failure to do so may compromise machine function and machine life and may result in a hazardous situation.

NOTE: Keep your MacDon publications up-to-date. The most current version can be downloaded from our website www.macdon.com or from our Dealer-only site (<https://portal.macdon.com>) (login required).

List of Revisions

The following list provides an account of major changes from the previous version of this document.

Summary of Changes	Location
Changed measurement format so that metric appear first followed by imperial in parenthesis.	Throughout the book
Added Steps and Notes in procedure.	3.1 Removing Underside Shipping Support and Installing Auger Pan, page 7
Changed illustration to show safety latch on front cover.	3.7 Unpacking Curtains, page 18
Changed illustrations to show updated forming shield.	<ul style="list-style-type: none"> • 3.9 Assembling Forming Shield, page 24 • 3.10 Installing Forming Shield, page 27
Added topics.	<ul style="list-style-type: none"> • 3.12.1 Attaching Header to an M1240 Windrower: Hydraulic Center-Link with Optional Self-Alignment, page 45 • 3.12.2 Attaching Header to an M1240 Windrower: Hydraulic Center-Link without Self-Alignment, page 50 • 3.13.3 Attaching Hydraulics and Electrical: M1240 Windrowers, page 67 • 5.1.8 Tapered Pipe Thread Fittings, page 107
Changed topic tiles.	<ul style="list-style-type: none"> • 3.13.1 Attaching Hydraulics and Electrical: M205 Windrowers, page 56 • 3.13.2 Attaching Hydraulics and Electrical: M200 Windrowers, page 61

TABLE OF CONTENTS

Introduction	i
List of Revisions	ii
1 Safety	1
1.1 Signal Words	1
1.2 General Safety	2
1.3 Safety Signs	4
2 Unloading the Header	5
3 Assembling the Header	7
3.1 Removing Underside Shipping Support and Installing Auger Pan	7
3.2 Installing Skid Shoes (Optional)	9
3.3 Installing Gauge Rollers (Optional)	10
3.4 Lowering Header	11
3.5 Removing Shipping Stands	13
3.6 Installing Swath Baffle Lever	17
3.7 Unpacking Curtains	18
3.8 Attaching Conditioner Cover	22
3.9 Assembling Forming Shield	24
3.10 Installing Forming Shield	27
3.11 Attaching Header to an M-Series Windrower	30
3.11.1 Attaching Header to an M200 or M205 Windrower: Hydraulic Center-Link with Optional Self-Alignment	30
3.11.2 Attaching Header to an M200 or M205 Windrower: Hydraulic Center-Link without Self-Alignment	35
3.11.3 Attaching Header to an M200 Windrower: Mechanical Center-Link	40
3.12 Attaching Header to an M1-Series Windrower	45
3.12.1 Attaching Header to an M1240 Windrower: Hydraulic Center-Link with Optional Self-Alignment	45
3.12.2 Attaching Header to an M1240 Windrower: Hydraulic Center-Link without Self-Alignment	50
3.13 Attaching Hydraulic and Electrical Connections	56
3.13.1 Attaching Hydraulics and Electrical: M205 Windrowers	56
3.13.2 Attaching Hydraulics and Electrical: M200 Windrowers	61
3.13.3 Attaching Hydraulics and Electrical: M1240 Windrowers	67
3.14 Installing Other Options	69
3.14.1 Installing Tall Crop Divider	69
3.14.2 Installing Double Windrow Attachment (DWA)	70
3.14.3 Installing Skid Shoes (Optional)	70
3.14.4 Installing Gauge Rollers (Optional)	71
3.14.5 Installing Tall Crop Feed Plates	72
3.14.6 Installing Nut Protectors (for Blade Hardware on Discs)	72
3.15 Header Lubrication	73
3.15.1 Driveshields	73
Opening the Driveshield: North American Headers	73
Closing the Driveshield: North American Headers	74
Opening the Driveshield: Export Headers	74
Closing the Driveshield: Export Headers	75
3.15.2 Greasing Procedure	75
3.15.3 Lubrication Points	75
4 Performing Predelivery Checks	79
4.1 Checking Drive Belts	79
4.2 Checking Header Float	81
4.3 Checking Header Level	82
4.4 Checking Conditioner Rolls	84
4.4.1 Checking Conditioner Roll Gap	84

TABLE OF CONTENTS

4.4.2	Checking Conditioner Roll Timing.....	85
4.5	Checking Gauge Rollers or Skid Shoes.....	87
4.6	Preparing the Bevel Gearbox.....	88
4.7	Preparing the Conditioner Gearbox.....	89
4.8	Checking Lights.....	91
4.9	Checking Manuals.....	92
4.10	Running up the Header.....	93
5	Reference.....	95
5.1	Torque Specifications.....	95
5.1.1	SAE Bolt Torque Specifications.....	95
5.1.2	Metric Bolt Specifications.....	97
5.1.3	Metric Bolt Specifications Bolting into Cast Aluminum.....	100
5.1.4	Flare-Type Hydraulic Fittings.....	100
5.1.5	O-Ring Boss (ORB) Hydraulic Fittings (Adjustable).....	102
5.1.6	O-Ring Boss (ORB) Hydraulic Fittings (Non-Adjustable).....	104
5.1.7	O-Ring Face Seal (ORFS) Hydraulic Fittings.....	105
5.1.8	Tapered Pipe Thread Fittings.....	107
5.2	Conversion Chart.....	108
5.3	Definitions.....	109
	Predelivery Checklist.....	111

1 Safety

1.1 Signal Words

Three signal words, **DANGER**, **WARNING**, and **CAUTION**, are used to alert you to hazardous situations. The appropriate signal word for each situation has been selected using the following guidelines:

DANGER

Indicates an imminently hazardous situation that, if not avoided, will result in death or serious injury.

WARNING

Indicates a potentially hazardous situation that, if not avoided, could result in death or serious injury. It may also be used to alert against unsafe practices.

CAUTION

Indicates a potentially hazardous situation that, if not avoided, may result in minor or moderate injury. It may be used to alert against unsafe practices.

1.2 General Safety

CAUTION

The following are general farm safety precautions that should be part of your operating procedure for all types of machinery.

Protect yourself.

- When assembling, operating, and servicing machinery, wear all the protective clothing and personal safety devices that could be necessary for the job at hand. Do **NOT** take chances. You may need the following:
 - Hard hat
 - Protective footwear with slip resistant soles
 - Protective glasses or goggles
 - Heavy gloves
 - Wet weather gear
 - Respirator or filter mask
- Be aware that exposure to loud noises can cause hearing impairment or loss. Wear suitable hearing protection devices such as ear muffs or ear plugs to help protect against objectionable or loud noises.

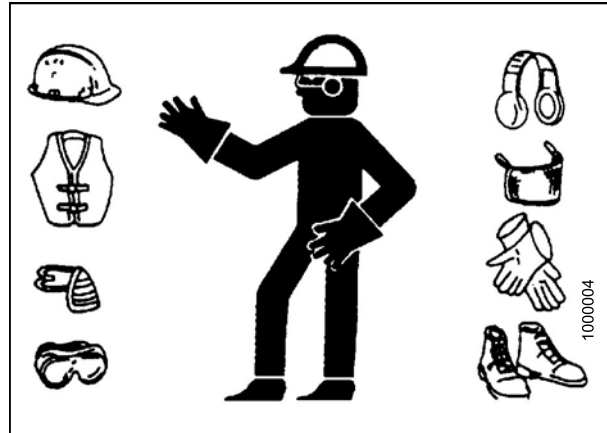

Figure 1.1: Safety Equipment



Figure 1.2: Safety Equipment

- Provide a first aid kit for use in case of emergencies.
- Keep a fire extinguisher on the machine. Be sure the fire extinguisher is properly maintained. Be familiar with its proper use.
- Keep young children away from the machinery at all times.
- Be aware that accidents often happen when the Operator is tired or in a hurry. Take the time to consider the safest way. Never ignore the warning signs of fatigue.

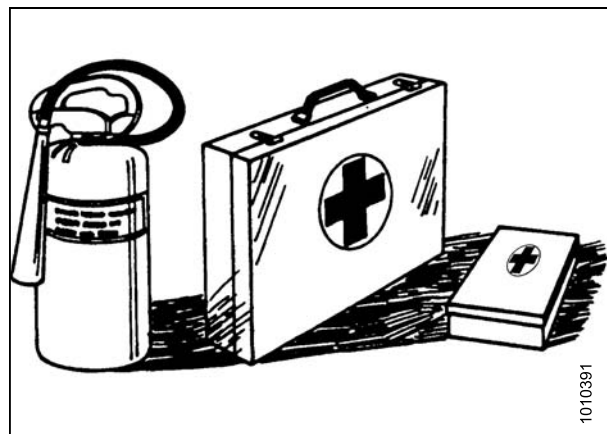

Figure 1.3: Safety Equipment

SAFETY

- Wear close-fitting clothing and cover long hair. Never wear dangling items such as scarves or bracelets.
- Keep all shields in place. **NEVER** alter or remove safety equipment. Make sure driveline guards can rotate independently of the shaft and can telescope freely.
- Use only service and repair parts made or approved by the equipment manufacturer. Substituted parts may not meet strength, design, or safety requirements.



Figure 1.4: Safety around Equipment

- Keep hands, feet, clothing, and hair away from moving parts. **NEVER** attempt to clear obstructions or objects from a machine while the engine is running.
- Do **NOT** modify the machine. Non-authorized modifications may impair machine function and/or safety. It may also shorten the machine's life.
- To avoid bodily injury or death from unexpected startup of machine, **ALWAYS** stop the engine and remove the key from ignition before leaving operator's seat for any reason.

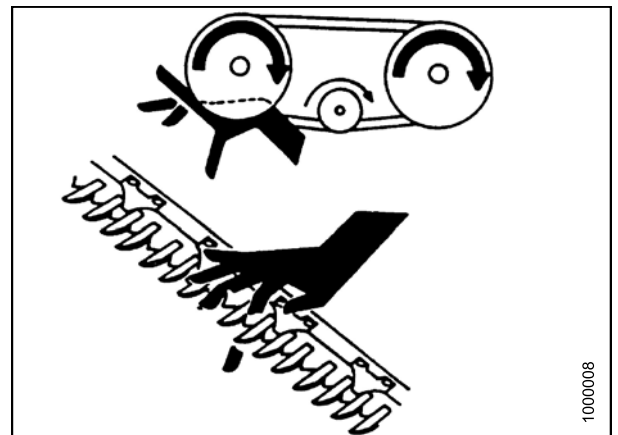

Figure 1.5: Safety around Equipment

- Keep the service area clean and dry. Wet or oily floors are slippery. Wet spots can be dangerous when working with electrical equipment. Be sure all electrical outlets and tools are properly grounded.
- Keep work area well lit.
- Keep machinery clean. Straw and chaff on a hot engine is a fire hazard. Do **NOT** allow oil or grease to accumulate on service platforms, ladders, or controls. Clean machines before storage.
- **NEVER** use gasoline, naphtha, or any volatile material for cleaning purposes. These materials may be toxic and/or flammable.
- When storing machinery, cover sharp or extending components to prevent injury from accidental contact.



Figure 1.6: Safety around Equipment

1.3 Safety Signs

- Keep safety signs clean and legible at all times.
- Replace safety signs that are missing or become illegible.
- If original parts on which a safety sign was installed are replaced, be sure the repair part also bears the current safety sign.
- Safety signs are available from your MacDon Dealer.

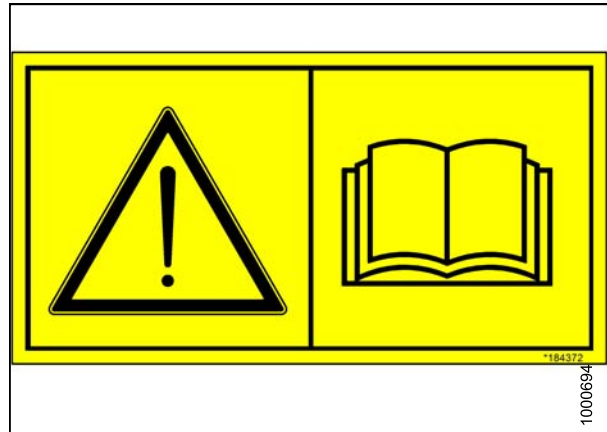

Figure 1.7: Operator's Manual Decal

2 Unloading the Header

CAUTION

To avoid injury to bystanders from being struck by machinery, do NOT allow people to stand in unloading area.

CAUTION

Equipment used for unloading must meet or exceed the requirements specified below. Using inadequate equipment may result in chain breakage, vehicle tipping, or machine damage.

Table 2.1 Lifting Vehicle

Minimum Capacity ¹	3630 kg (8000 lb.)
Minimum Fork Length	198 cm (78 in.)

IMPORTANT:

Forklifts are normally rated for a load located 610 mm (24 in.) ahead of the back end of the forks. To obtain the forklift capacity at 1220 mm (48 in.), check with your forklift distributor.

1. Remove hauler's tie-down straps and chains.

WARNING

Be sure forks are secure before moving away from load. Stand clear when lifting.

2. Approach header from its underside and slide forks in under the lifting framework as far as possible.

IMPORTANT:

If load is two units wide, take care to avoid contacting the other machine.

3. Raise header off the deck.
4. Back up until the unit clears trailer, and slowly lower to 150 mm (6 in.) from the ground.
5. Take to storage or setup area.
6. Set machine down on secure, level ground.
7. If hydraulic motor and hoses are shipped separately on pallet, unload pallet.
8. Check for shipping damage and missing parts.



Figure 2.1: Lifting Header off Trailer



Figure 2.2: Moving Header with Forklift

1. At 1220 mm (48 in.) from back end of forks.

3 Assembling the Header

3.1 Removing Underside Shipping Support and Installing Auger Pan

CAUTION

Keep feet clear when removing final bolts.

1. Use a forklift to support stand.
2. Remove two bolts (A) on each end of support and remove shipping support (B). Lay support on ground.

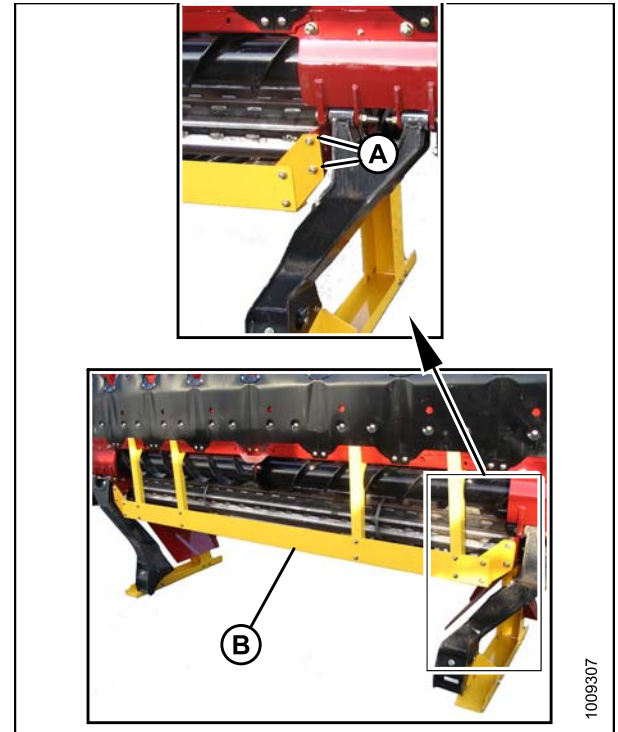

Figure 3.1: Shipping Support

3. Cut banding (A), and remove auger pan (B) and hardware from stand. Discard stand.
4. Locate the hardware bag strapped between auger pan (B) and the stand.

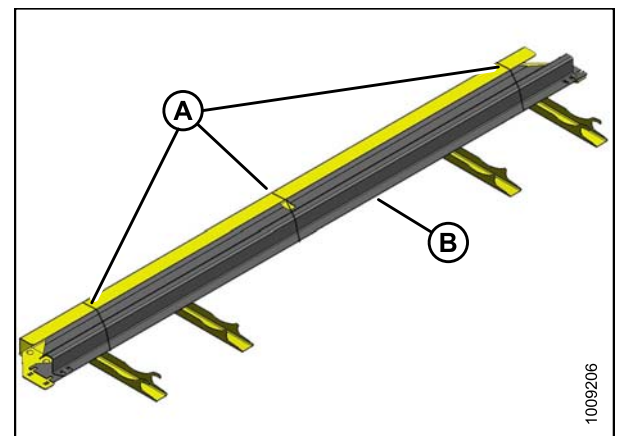

Figure 3.2: Auger Pan Attached to Shipping Support

ASSEMBLING THE HEADER

5. Position auger pan (A) against cutterbar lugs and install four 1/2 x 3.5 in. long bolts (B) and lock nuts. Do not fully tighten.
6. Check and make sure that auger pan is oriented as shown.
7. Check and make sure that center pan is position evenly before tightening. Tighten enough so nut is locked and pan can still pivot.
8. Retrieve plates (C) from hardware bag, and install as shown at each end of pan with four 1/2 x 1.0 in. long bolts (D). Tighten hardware.

NOTE:

There may be a gap between the cutterbar lugs and the auger pan when tightening the hardware. The hardware does not need to pull the auger pan flush against the cutterbar lugs.

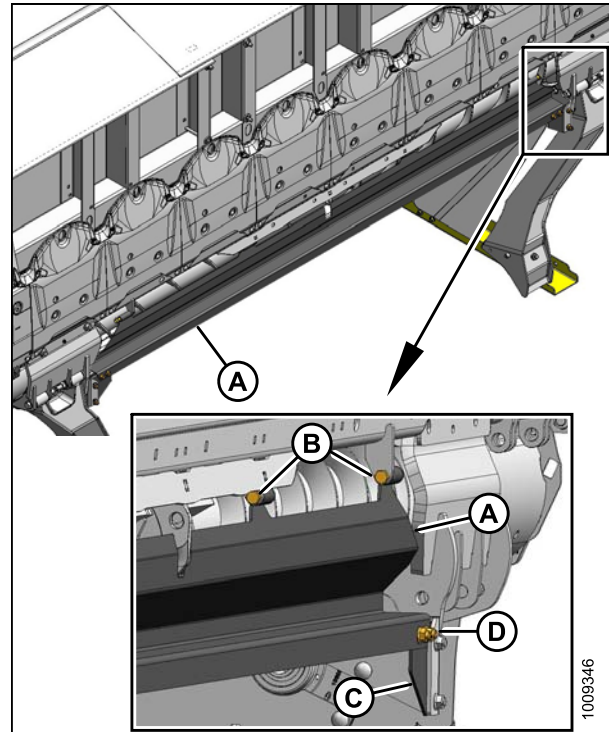

Figure 3.3: Auger Pan Installed

3.2 Installing Skid Shoes (Optional)

NOTE:

This kit may be installed later in the assembly sequence, but installation may be easier prior to laying the header down.

⚠ DANGER

To avoid bodily injury or death from unexpected startup of the machine, always stop the engine and remove the key from the ignition before leaving the operator's seat for any reason.

1. Lower header to the ground, shut off engine, and remove key from ignition.
2. Unpack kit.
3. Install skid shoes. Refer to instruction (MD #169972) supplied with kit.

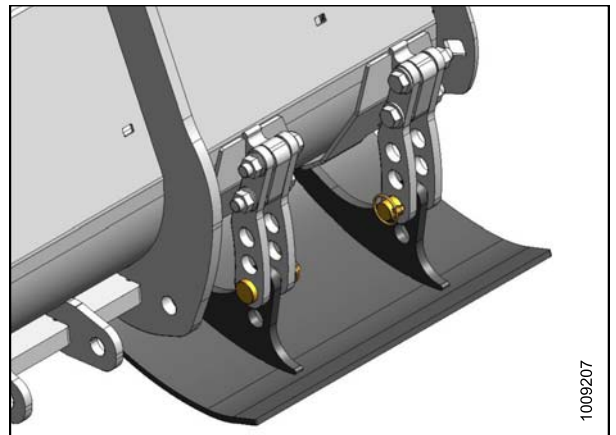

Figure 3.4: Skid Shoe (Right Side Shown – Left Side Similar)

3.3 Installing Gauge Rollers (Optional)

NOTE:

This kit may be installed later in the assembly sequence, but installation may be easier prior to laying the header down.

1. Unpack gauge roller bundle and install gauge rollers.
Refer to instruction (MD #169467) supplied with kit.

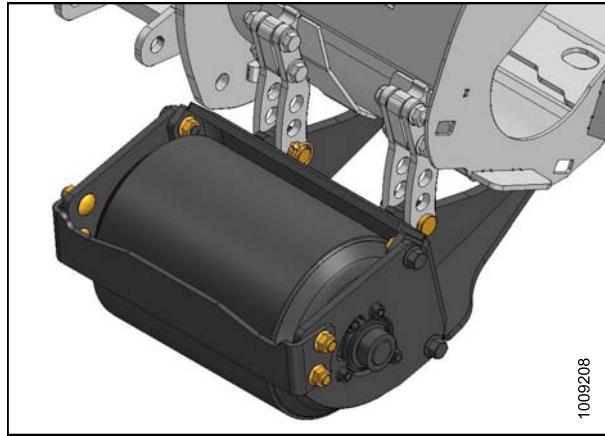

Figure 3.5: Gauge Roller (Right Side Shown – Left Side Similar)

3.4 Lowering Header

1. Attach spreader bar to forks.

IMPORTANT:

Length of spreader bar must be approximately 4.6 m (15 ft).

CAUTION

Ensure spreader bar is secured to the forks so that it cannot slide off the forks or towards the mast as the header is lowered to the ground.

Table 3.1 Lifting Vehicle

Chain Type	Overhead lifting quality 12.7 mm (1/2 in.)
Minimum Working Load	2270 kg (5000 lb.)

2. Drive lifting vehicle to approach header from its underside.
3. Attach chains to hooks (A) on both sides of header.

CAUTION

Stand clear when lowering the header

IMPORTANT:

Do **NOT** lift at hooks when unloading from trailer. This procedure is only for laying the machine over into working position.

IMPORTANT:

Chain length must be sufficient to provide a minimum 1.2 m (4 ft.) vertical chain height.

4. Raise forks until lift chains are fully tensioned.

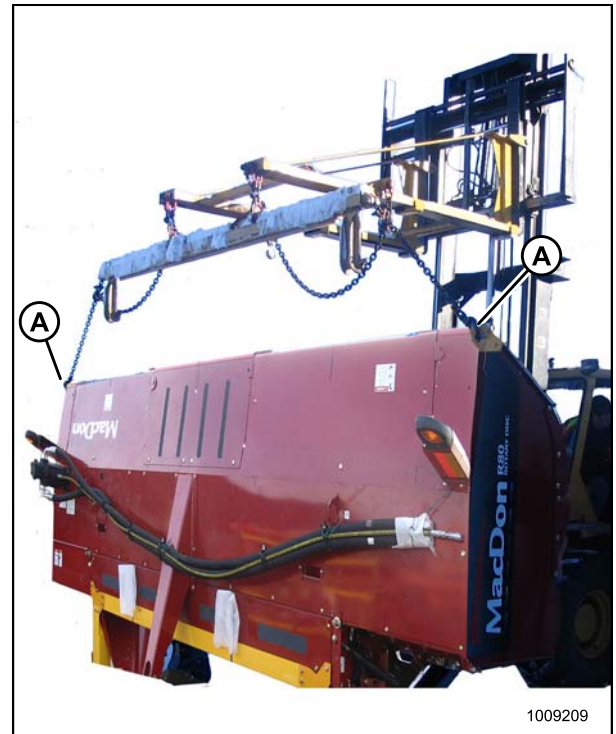

Figure 3.6: Spreader Bar Attached to Header

ASSEMBLING THE HEADER

5. Back up **SLOWLY**, while simultaneously lowering header until cutterbar rests on ground.
6. Remove chains from header.

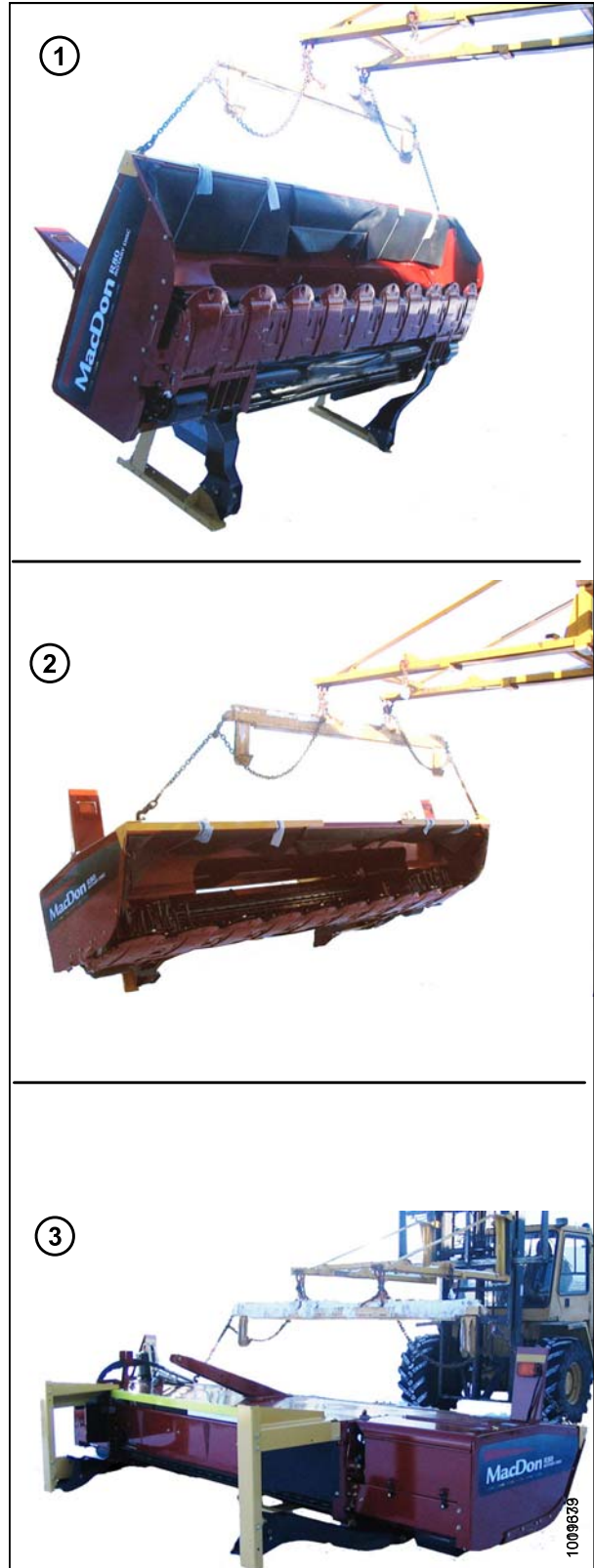

Figure 3.7: Lowering Header to the Ground

3.5 Removing Shipping Stands

1. Cut and remove banding (A) from baffle.

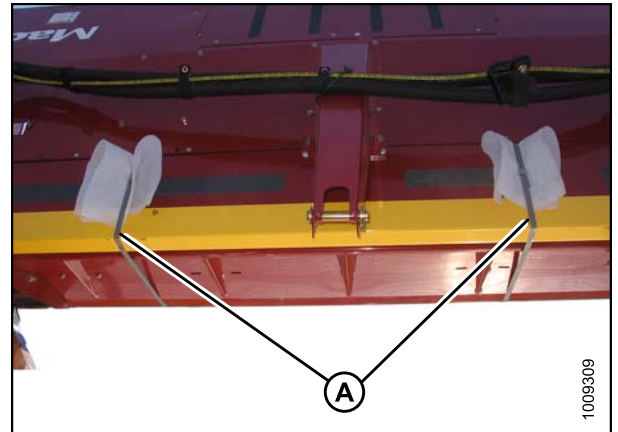

Figure 3.8: Banding on Baffle

2. Remove plate (A) from left-hand shipping stand (B) and set aside with hardware for reinstallation.

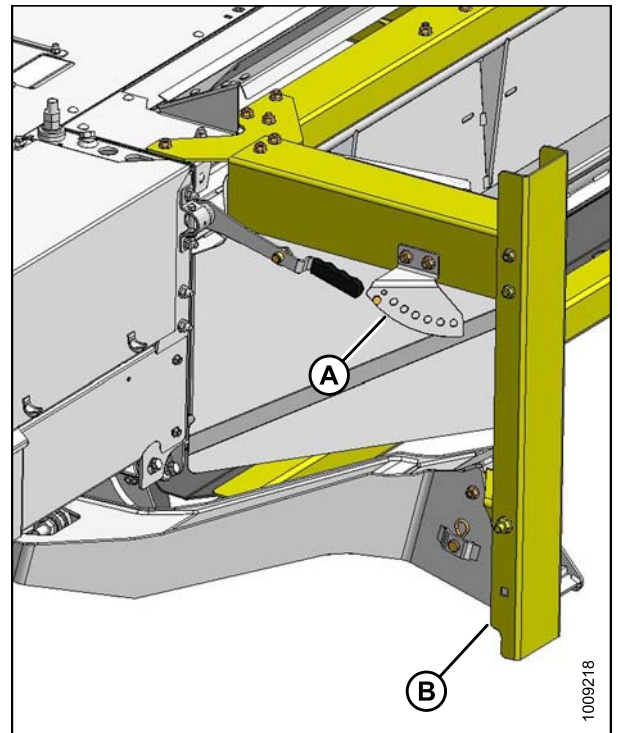

Figure 3.9: Shipping Stand (Left Side Shown – Right Side Opposite)

ASSEMBLING THE HEADER

3. Remove the three bolts (A) securing left-hand stand (B) to shipping channel plate and shield.

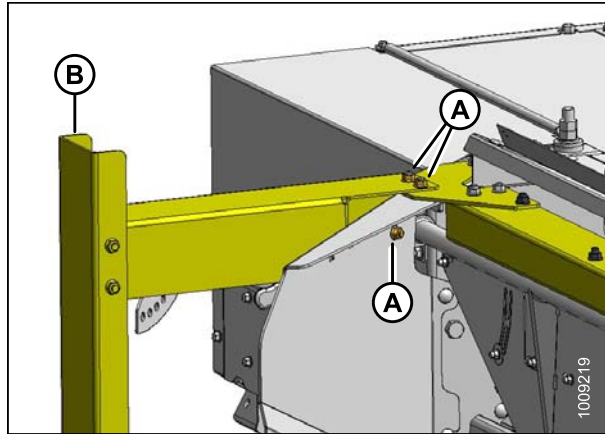

Figure 3.10: Shipping Stand (Left Side Shown – Right Side Opposite)

4. Remove bolt (A) securing shipping stand to header lifting arm.
5. Remove hairpin from pin (B).
6. Hold shipping stand, and remove pin (B).
7. Remove stand (C) and discard. Reinsert pin (B) in header lifting arm, and secure with lynch pin.
8. Repeat Step 3, page 14 to Step 7, page 14 for other stand.

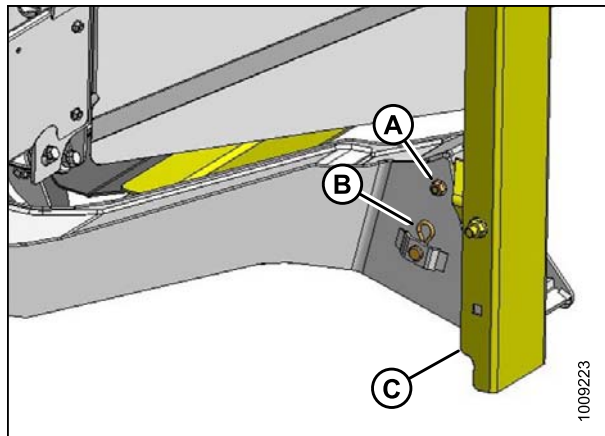

Figure 3.11: Shipping Stand (Left Side Shown – Right Side Opposite)

9. Raise baffle (A) with handle, and temporarily secure in raised position with wire.

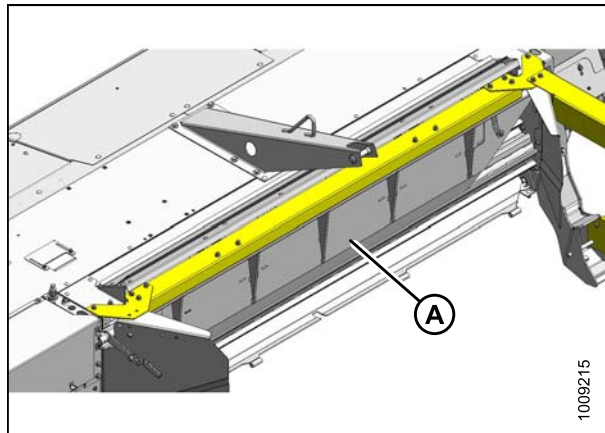

Figure 3.12: Shipping Stands

ASSEMBLING THE HEADER

10. Remove two bolts (A) attaching shipping channel (B) to frame. Retain hardware.

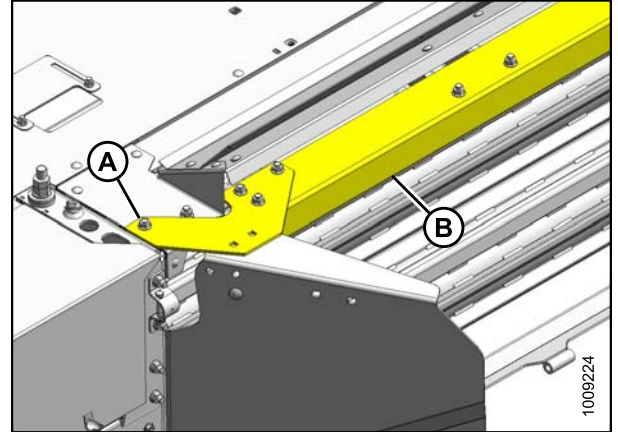

Figure 3.13: Shipping Stand (Left Side Shown – Right Side Opposite), Baffle Not Shown for Clarity

11. Remove the two bolts (A) attaching shipping channel (B) to frame. Retain hardware.
12. Remove wire and lower baffle so that channel can be removed.
13. Remove and discard channel (B).

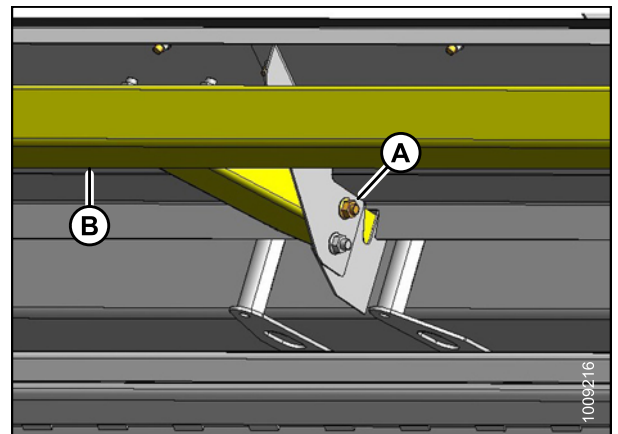

Figure 3.14: Shipping Stand (Left Side Shown – Right Side Opposite)

14. Reinstall two bolts (A) through frame and tighten.

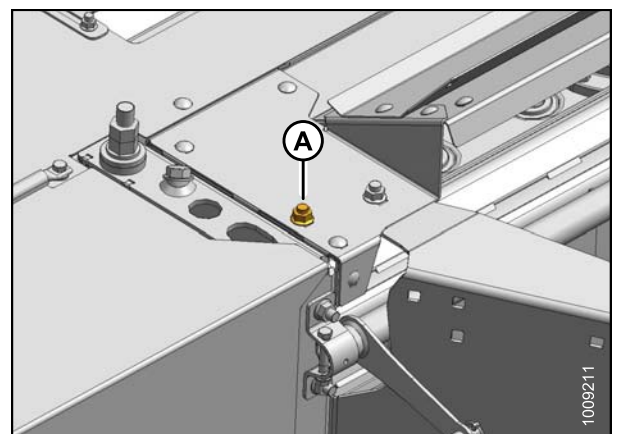

Figure 3.15: Frame with Shipping Stand Removed

ASSEMBLING THE HEADER

15. Reinstall two bolts (A) and lock nuts into cover support and tighten.

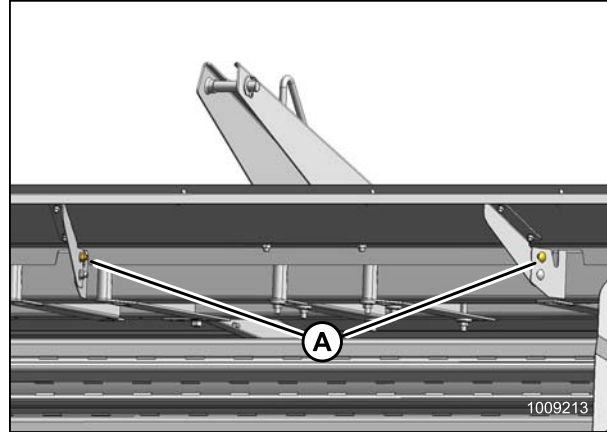

Figure 3.16: Frame with Shipping Stand Removed

16. Remove hooks (A) at front corners. Reinstall hardware.

NOTE:

If tall crop divider option will be installed, do not reinstall hardware.

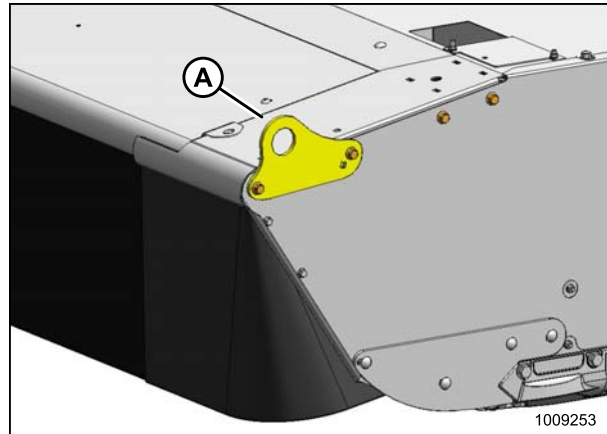

Figure 3.17: Shipping Hook

17. Remove wire, and lower baffle (A).

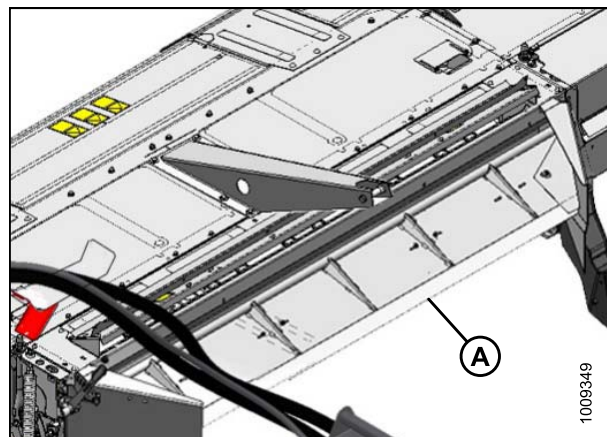

Figure 3.18: Swath Baffle

3.6 Installing Swath Baffle Lever

1. Retrieve adjuster plate and hardware previously removed from shipping stand (in [3.5 Removing Shipping Stands, page 13](#)).
2. Position adjuster plate (A) over holes on side deflector, and install bolts (E) and nuts. Do not tighten.
3. Remove bolt (B).
4. Remove lynch pin from clevis pin (D), and remove clevis pin from lever (C).

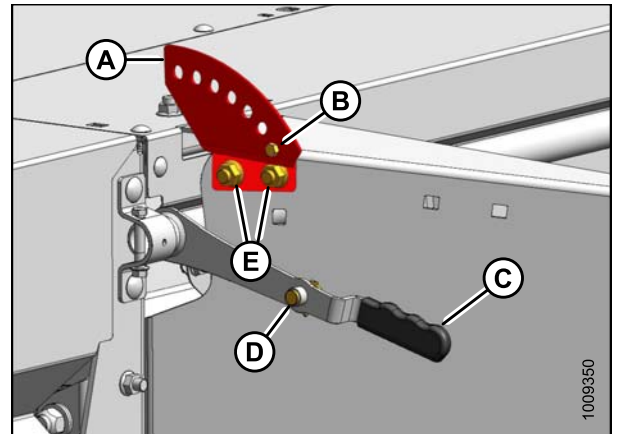

Figure 3.19: Adjuster Plate and Swath Baffle Lever

5. Move swath baffle lever (C) to middle hole in bracket (A), and reinstall clevis pin (D) through lever and bracket.
6. Secure with lynch pin.
7. Tighten bolts (G).

NOTE:

Baffle position may need to be adjusted for proper pin engagement. Loosen bolts (E), and adjust bracket (F) and baffle as required. Tighten bolts (E).

8. Reinstall nut and bolt (B).

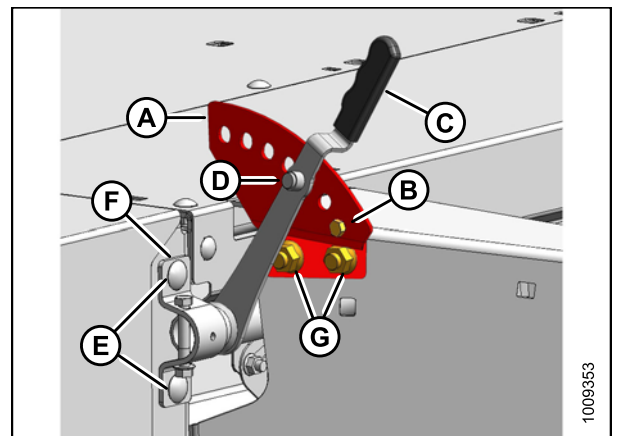

Figure 3.20: Adjuster Plate and Swath Baffle Lever

3.7 Unpacking Curtains

1. Remove two bolts (A) securing cutterbar doors to frame.
2. Remove shipping wire (B) from around curtains.

⚠ WARNING

Ensure cutterbar is completely clear of foreign objects. These objects can be ejected with considerable force when the machine is started and may result in serious injury or machine damage.

3. For export headers, insert a screwdriver (or equivalent) through hole (A) in door into notch in latch (B) and push latch to disengage.

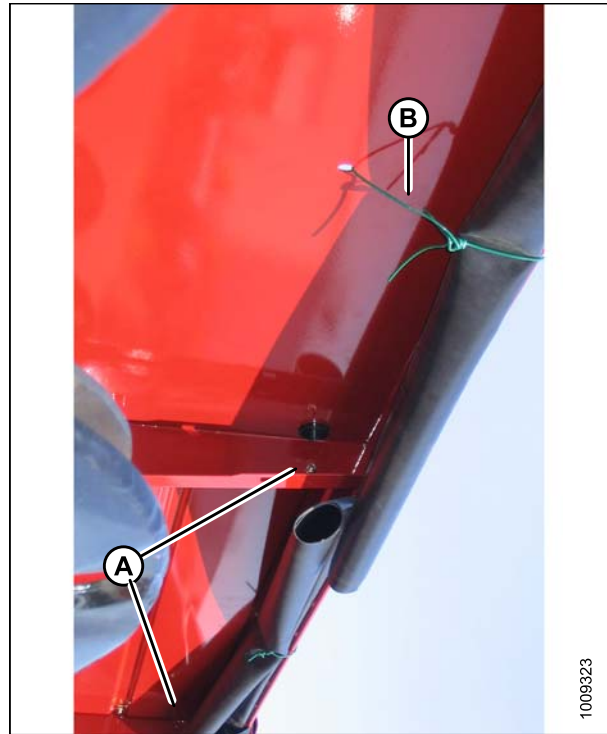

Figure 3.21: Cutterbar Door and Curtain Secured for Shipping

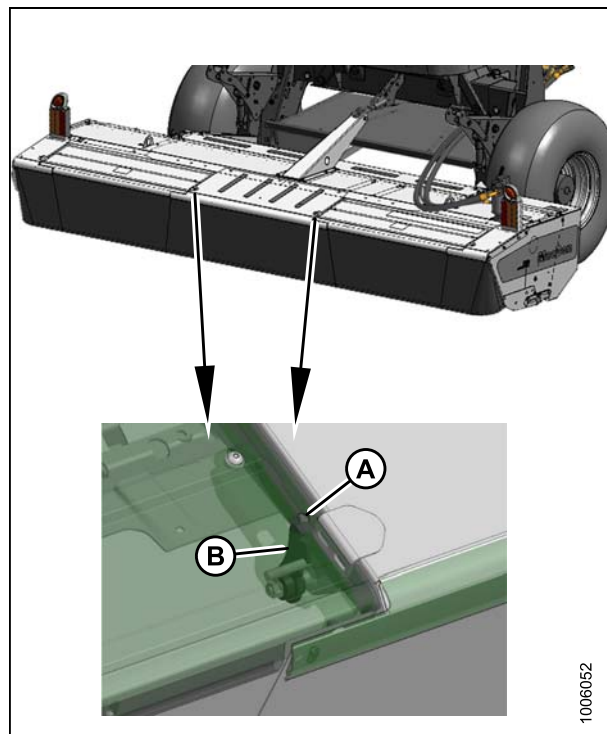

Figure 3.22: Export Headers: Latch on Cutterbar Doors

ASSEMBLING THE HEADER

4. Lift at front of door to open position.
5. Check cutterbar area for debris and foreign objects. Ensure all material is removed.

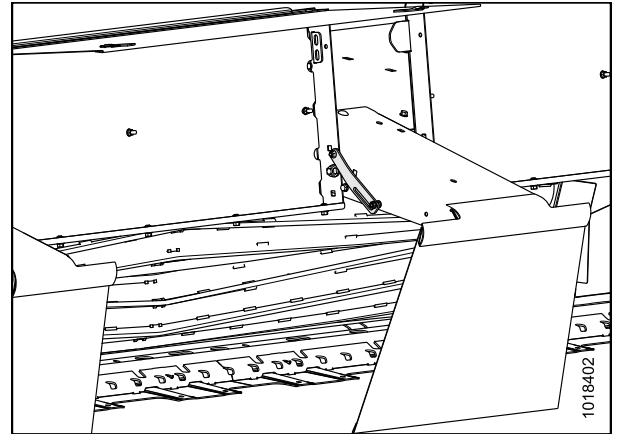

Figure 3.23: Cutterbar Doors Open

6. Close cutterbar doors. Ensure that curtains hang properly and completely enclose cutterbar area. Minor creases in curtains will eventually straighten out.



Figure 3.24: Curtain – Unacceptable



Figure 3.25: Curtain – Acceptable

ASSEMBLING THE HEADER

7. For export headers, ensure latches (A) engage cutterbar doors.

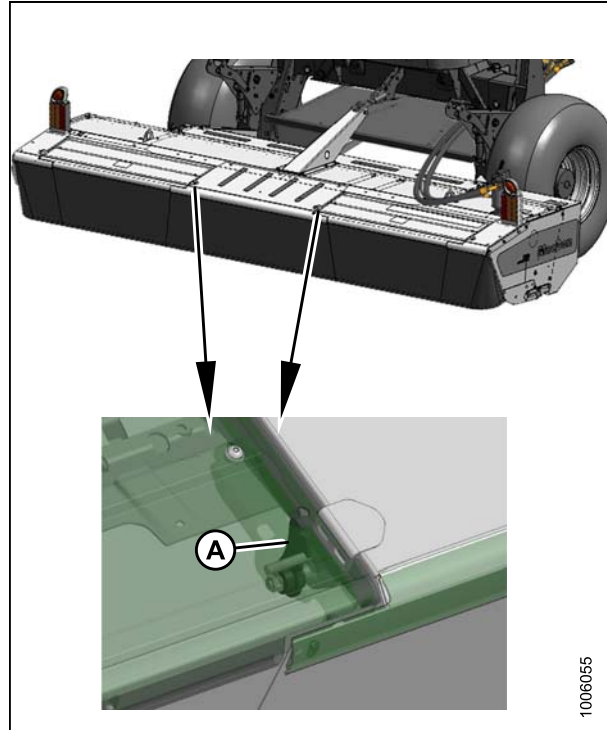

Figure 3.26: Cutterbar Door Latch

8. Fasten latches (A) at corners of curtains.

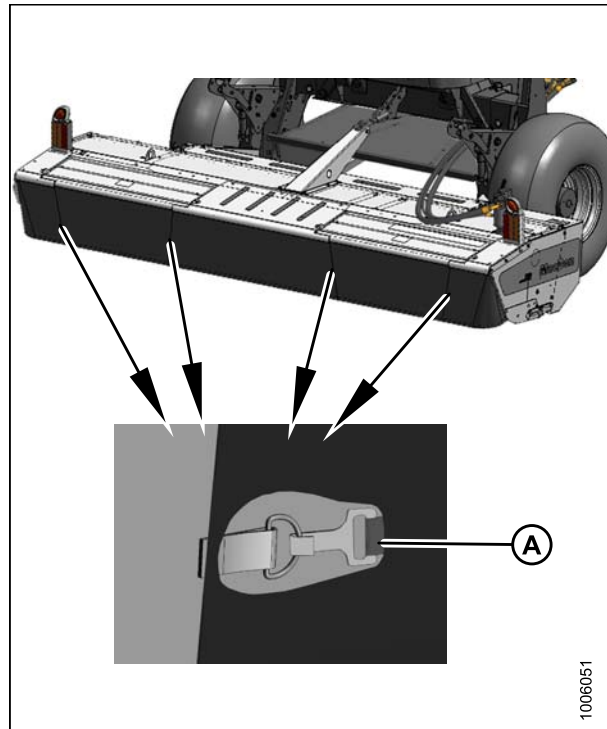

Figure 3.27: Curtain Latches

ASSEMBLING THE HEADER

9. Remove shipping edge trim (A).
10. Close the shields (B) over the two shipping tie-down holes and tighten nuts (C).

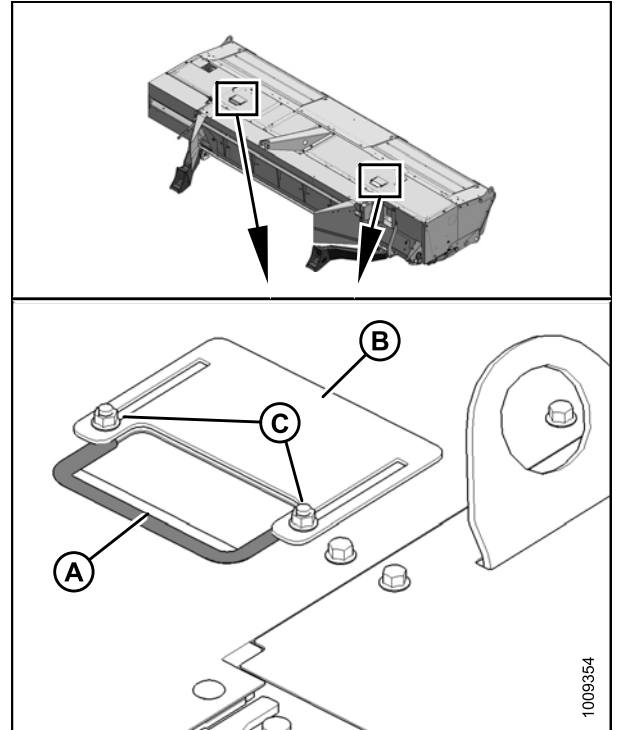

Figure 3.28: Top Shield Cover

11. Remove shipping wire/banding and packing around hydraulic hoses.

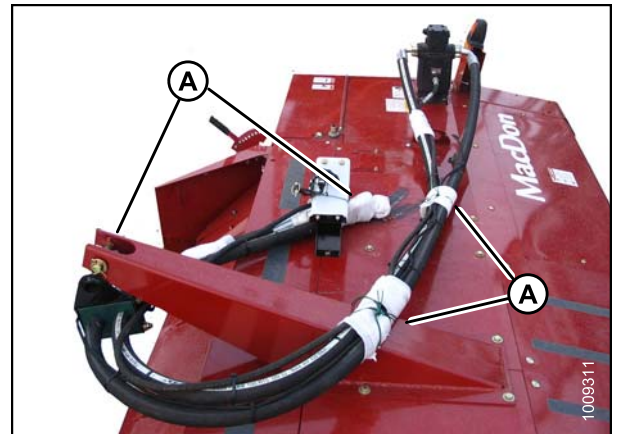

Figure 3.29: Shipping Material around Hoses

3.8 Attaching Conditioner Cover

1. Remove bolts (A) and remove cover (B) from shipping position.
2. Replace bolts (A) into existing holes.

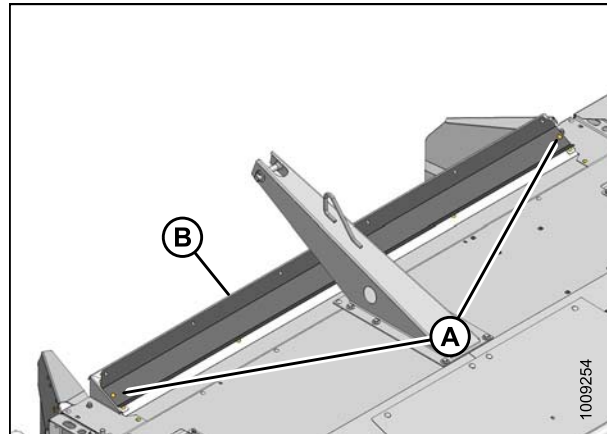

Figure 3.30: Cover in Shipping Configuration

3. Remove six carriage bolts (A) along aft edge.

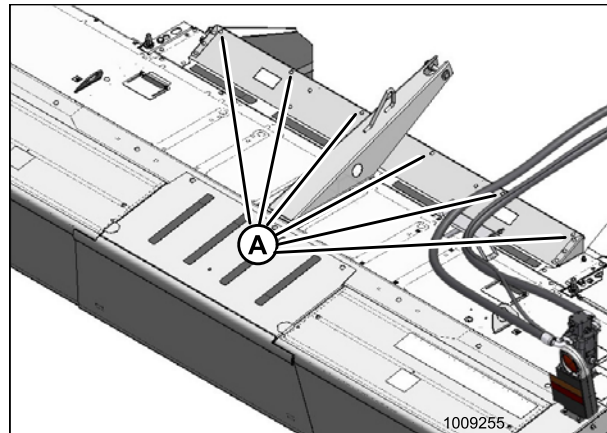

Figure 3.31: Hardware on Edge of Hood

ASSEMBLING THE HEADER

4. Position cover (A) on hood as shown and secure with six carriage bolts (B) and lock nuts.

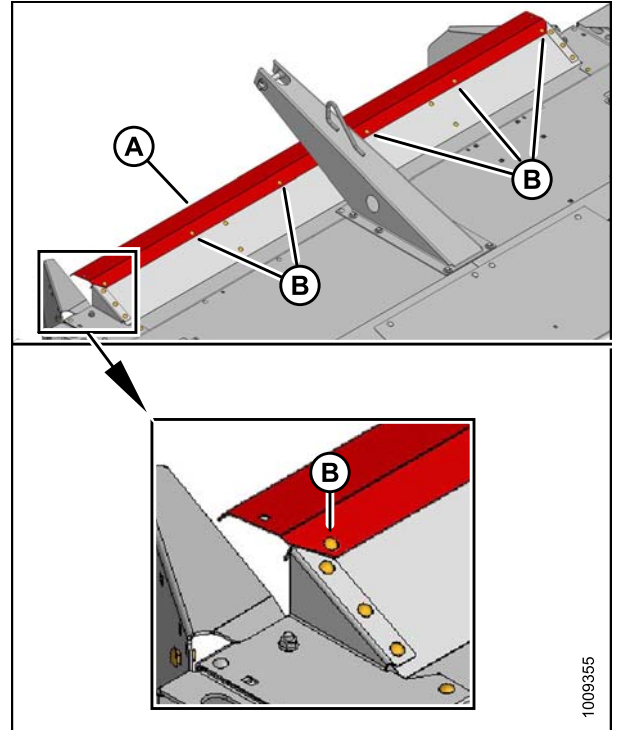

Figure 3.32: Cover Installed

3.9 Assembling Forming Shield

1. Unpack and remove shipping material from side deflectors (A).
2. Remove hardware bag (B).
3. Open the hardware bag.

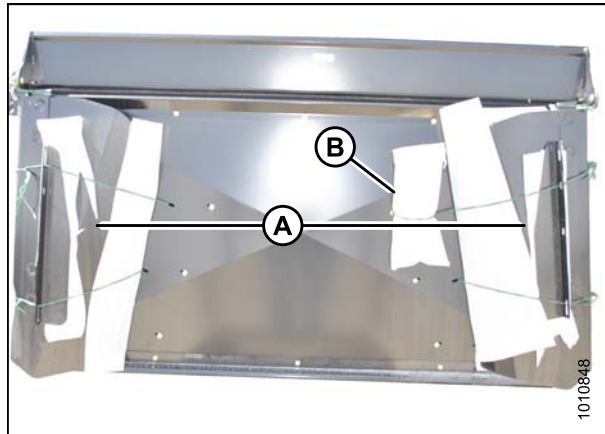

Figure 3.33: Forming Shield in Shipping Configuration

4. Install rubber strap (A) to the side bracket (B) using bolt (C), washer (D), and nut (E).
5. Repeat for the other side.

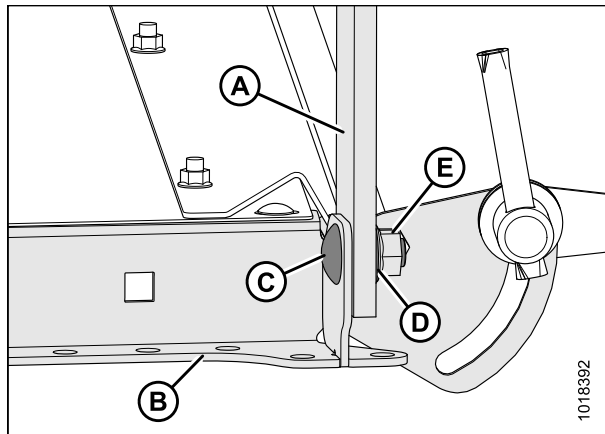

Figure 3.34: Forming Shield Cover Right Side Up

6. Lay cover (A) upside down on a flat surface.
7. Install the center deflectors (B) using three bolts and nuts (C) on each side.

NOTE:

The narrow end of deflector (B) faces the front, and the deep end faces the rear.

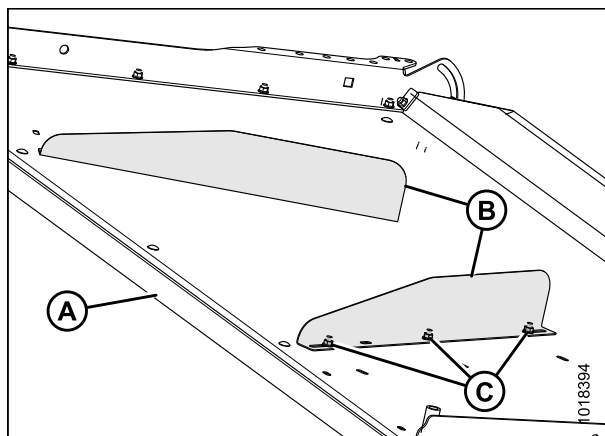

Figure 3.35: Forming Shield Cover Upside Down

ASSEMBLING THE HEADER

8. Assemble side deflectors (C) to cover with 5/8 x 10 in. bolt (B), jam nut (E), washer (D), and nut (A).
9. Tighten flange nut (A) enough to hold deflectors (C) in position, but still allow deflectors to move.
10. Tighten jam nut (E) against cover while holding bolt (B).

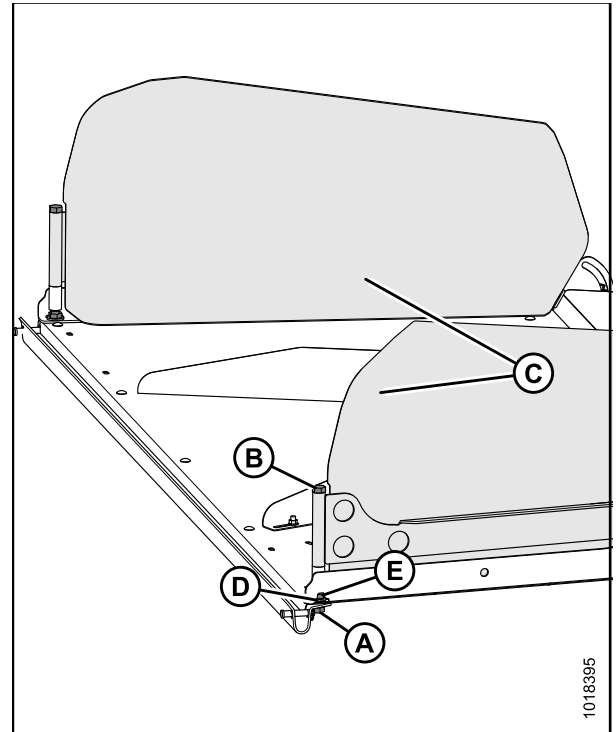

Figure 3.36: Forming Shield: Side Deflectors

11. Remove lynch pin (A) from adjuster rod (B), and position rod in hole in side deflector (C). Secure with lynch pin (A).
12. Repeat for other deflector.

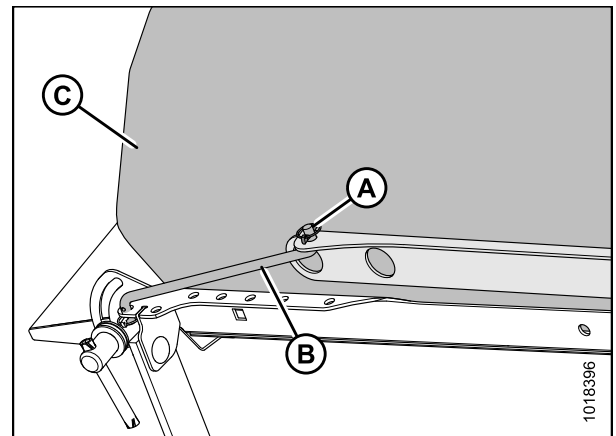

Figure 3.37: Positioning Adjuster Rod

ASSEMBLING THE HEADER

13. Invert forming shield to installation position as shown.

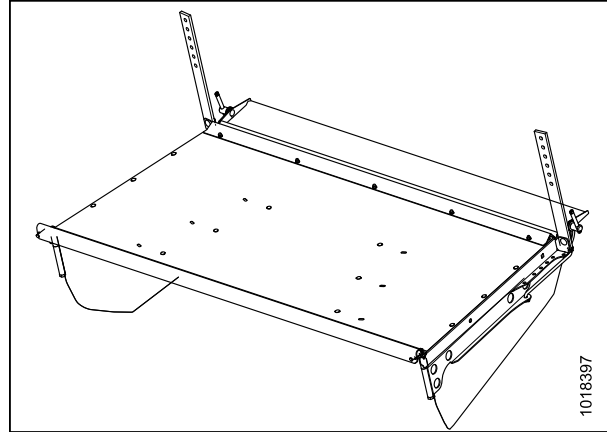

Figure 3.38: Forming Shield Right Side Up

14. **For M205 Self-Propelled Windrowers Only:** Install hose support (A) to the left-hand side of the top shield (B) and channel (C) using two bolts and nuts (D).

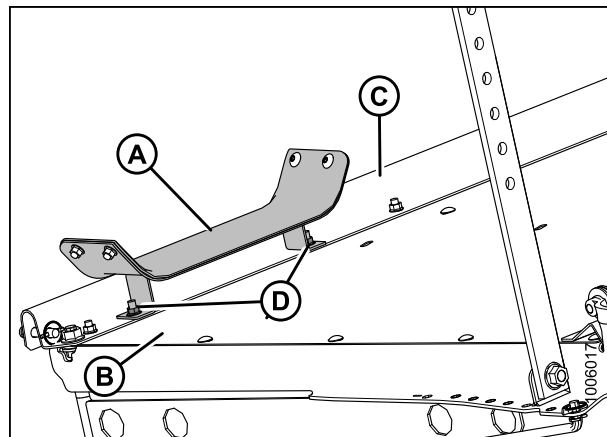

Figure 3.39: M205 Hose Support

NOTE:

If there are no mounting slots for the hose support, drill two 11 mm (7/16 in.) holes (A) through top shield (B) and channel (C).

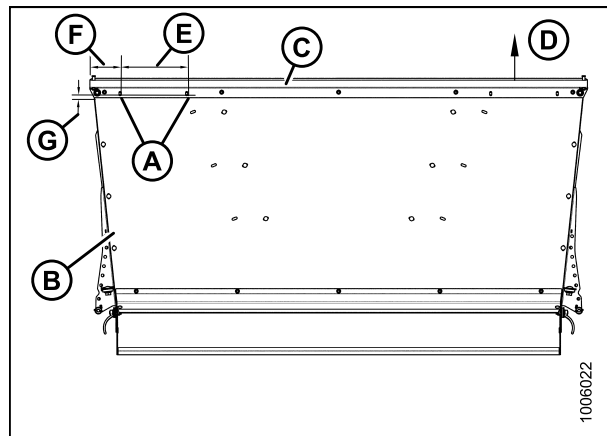

Figure 3.40: Forming Shield Top View

A - Two 11 mm (7/16 in.) Holes	B - Top Shield
C - Channel	D - Header Forward
E - 320 mm (12.6 in.)	F - 144.8 mm (5.7 in.)
G - 19.5 mm (0.77 in.)	

3.10 Installing Forming Shield

To install the forming shield, follow these steps:

1. To ease forming shield installation, remove header from windrower (if attached). Refer to your windrower operator's manual for instructions.
2. Retrieve plate (A) and attachment hardware from forming shield bundle.
3. Attach plate (A) to windrower leg with two 1/2 x 5-1/4 in. hex bolts (B) and nuts. Repeat for opposite leg. Hardware is supplied with forming shield bundle.

IMPORTANT:

Plate (A) is shown in standard position. If installing double windrow attachment (DWA), install plate in inverted position.

4. Install a 1/2 x 4 in. hex bolt (C) with spacer (D) and nut on each plate. Hardware is supplied with forming shield bundle.
5. Remove the two clevis pins (A) from forming shield forward end.

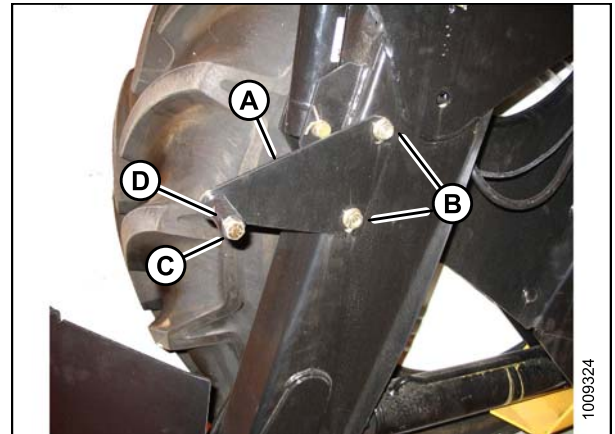

Figure 3.41: Attaching Plate to Windrower Leg

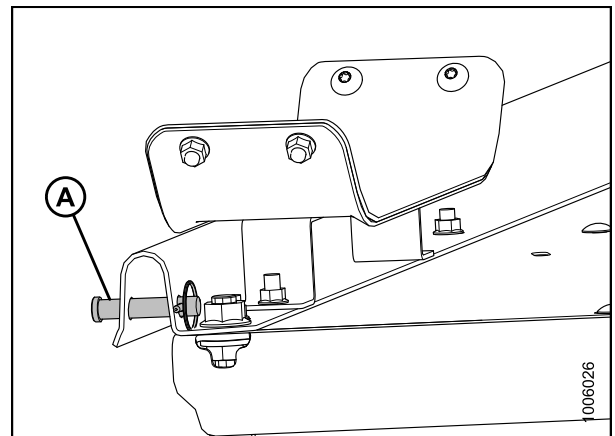

Figure 3.42: Clevis Pin at Forward End of Forming Shield

ASSEMBLING THE HEADER

6. Position the forming shield (A) under the windrower frame.

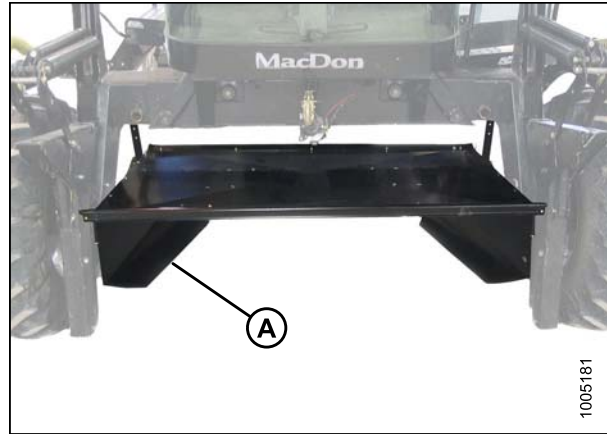

Figure 3.43: Forming Shield under Windrower Frame

7. Position the forming shield onto spacers (B) on windrower legs. Secure with clevis pins (A) and lynch pin.

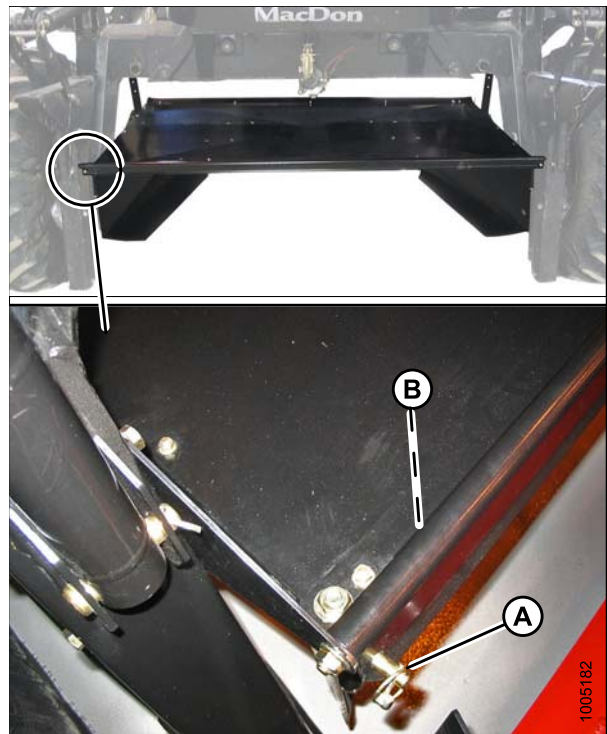

Figure 3.44: Attaching Forming Shield to Windrower Legs

ASSEMBLING THE HEADER

8. Lift the aft end of the forming shield and attach straps (B) to pins (A) on windrower frame. Install washer and hairpin to secure strap. Use the middle hole and adjust height to suit the crop.

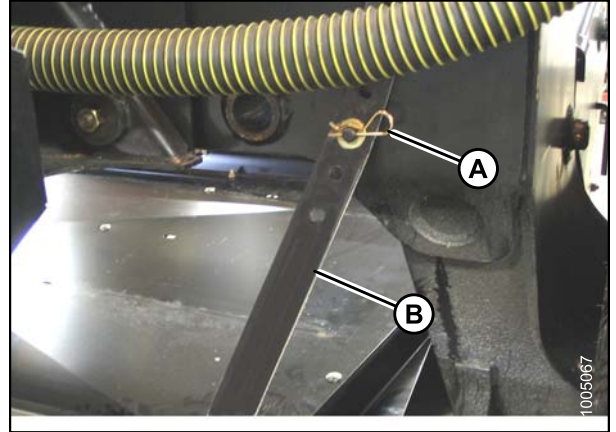

Figure 3.45: Attaching Forming Shield to Windrower Frame

9. Set the forming shield side deflectors to the desired width by repositioning adjuster bars (A). Use the same hole location on both sides.
10. Adjust rear fluffer deflector (C) to middle position. Loosen handles (B) if required.

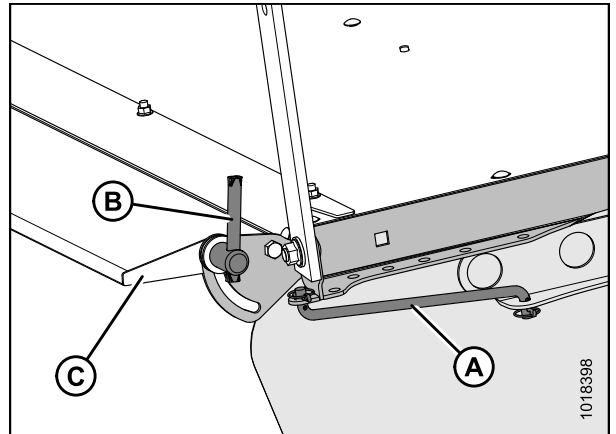

Figure 3.46: Adjusting Forming Shield

3.11 Attaching Header to an M-Series Windrower

The procedure for attaching the header to an M-series windrower varies depending on the type of center-link installed. The center-link consists of either a hydraulic cylinder that adjusts the header tilt or angle and is controlled with switches in the windrower cab, or a manually adjusted mechanical link.

An optional self-alignment kit controls the alignment of the center-link when attaching the link to the header.

Follow the appropriate procedure:

- [3.11.1 Attaching Header to an M200 or M205 Windrower: Hydraulic Center-Link with Optional Self-Alignment, page 30](#)
- [3.11.2 Attaching Header to an M200 or M205 Windrower: Hydraulic Center-Link without Self-Alignment, page 35](#)
- [3.11.3 Attaching Header to an M200 Windrower: Mechanical Center-Link, page 40](#)

NOTE:

Refer to your windrower operator's manual for windrower operating instructions.

3.11.1 Attaching Header to an M200 or M205 Windrower: Hydraulic Center-Link with Optional Self-Alignment

DANGER

To avoid bodily injury or death from unexpected startup of the machine, always stop the engine and remove the key from the ignition before leaving the operator's seat for any reason.

1. Remove hairpin (B) from clevis pin (A) and remove clevis pin from the header boots (C) on both sides of the header.

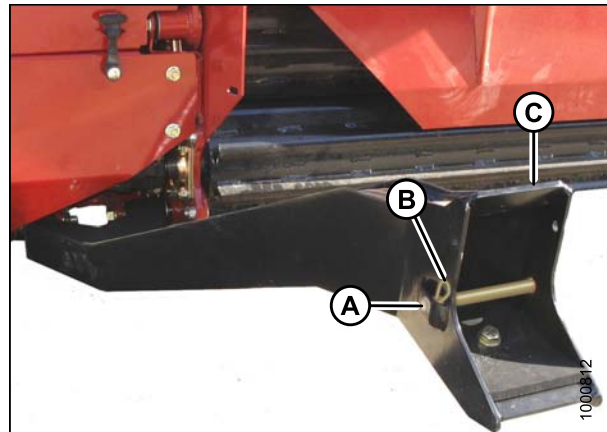

Figure 3.47: Header Boot

ASSEMBLING THE HEADER

CAUTION

To prevent damage to the lift system when lowering header lift linkages without a header or weight box attached to the windrower, ensure the float engagement pin is installed in storage position (B) and NOT in engaged position (A).

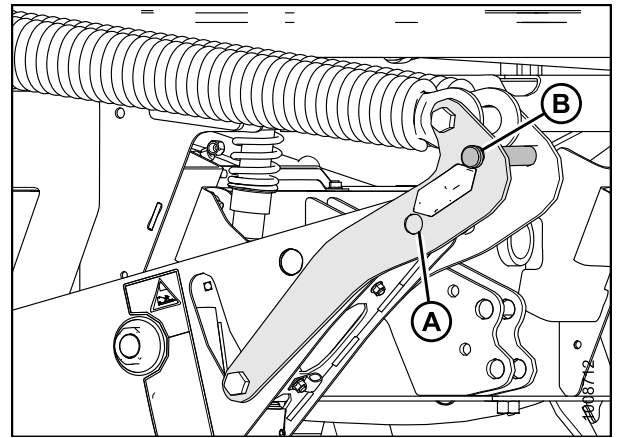

Figure 3.48: Header Float Linkage

CAUTION

Check to be sure all bystanders have cleared the area.

IMPORTANT:

Before starting engine, remove protective cover from exhaust stack.

2. Start the engine and activate the HEADER DOWN button (A) on the ground speed lever (GSL) to fully retract header lift cylinders.

IMPORTANT:

If the center-link is too low, it may contact the header as the windrower approaches the header for hookup.

3. Activate the REEL UP switch (A) on the GSL to raise the center-link until the hook is above the attachment pin on the header.

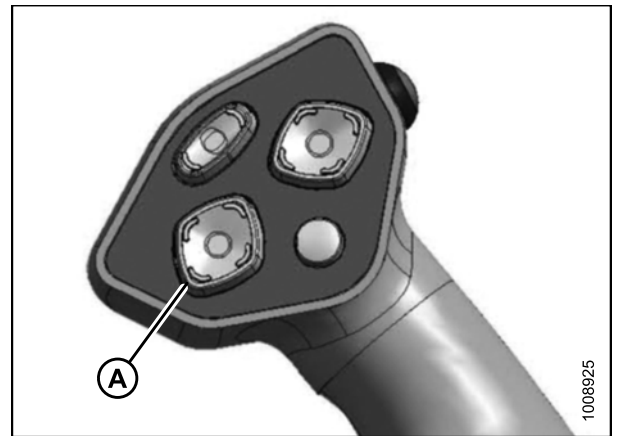

Figure 3.49: Ground Speed Lever

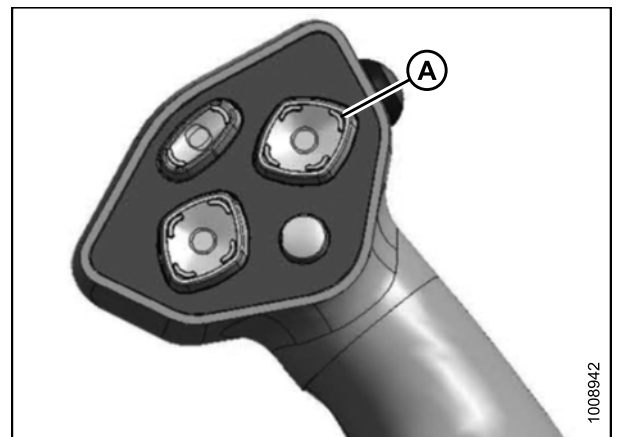

Figure 3.50: Ground Speed Lever

ASSEMBLING THE HEADER

4. Drive the windrower slowly forward until the windrower feet (A) enter the header boots (B). Continue driving slowly forward until the feet engage the boots and the header nudges forward.

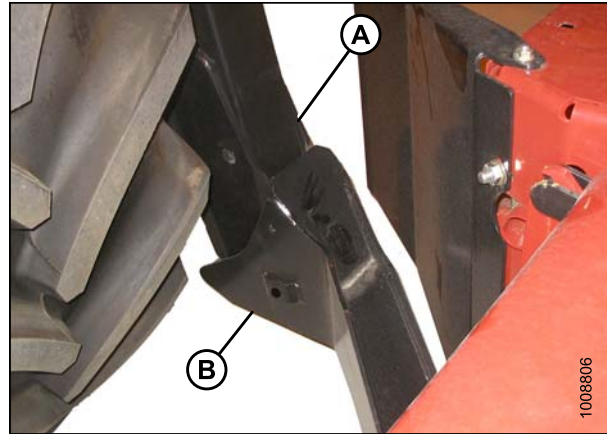

Figure 3.51: Header Boot

5. Use the following GSL functions to position the center-link hook above the header attachment pin:
 - Reel up (A) to raise the center-link
 - Reel down (B) to lower the center-link
 - Header tilt up (C) to retract the center-link
 - Header tilt down (D) to extend the center-link

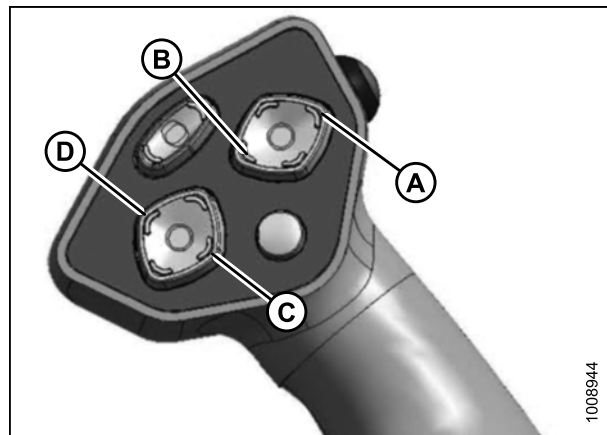

Figure 3.52: Ground Speed Lever

6. Adjust position of the center-link cylinder (A) with the REEL UP and REEL DOWN switches on the GSL until the hook is positioned above the header attachment pin.

IMPORTANT:

Hook release must be down to enable self-locking mechanism. If the release is open (up), manually push it down after hook engages header pin.

7. Lower center-link (A) onto the header with REEL DOWN switch until it locks into position (hook release [B] is down).
8. Check that center-link is locked onto header by pressing the REEL UP switch on the GSL.

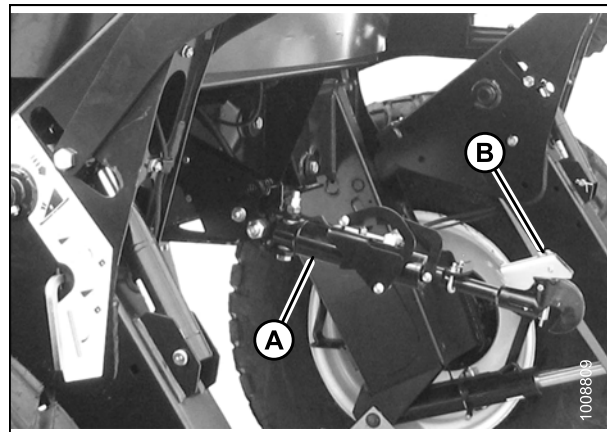

Figure 3.53: Hydraulic Center-Link

ASSEMBLING THE HEADER

CAUTION

Check to be sure all bystanders have cleared the area.

9. Press the HEADER UP switch (A) to raise header to maximum height.

NOTE:

If one end of the header does **NOT** fully rise, rephase the lift cylinders as follows:

- a. Press and hold the HEADER UP switch until both cylinders stop moving.
- b. Continue to hold the switch for 3–4 seconds. Cylinders are now phased.

NOTE:

It may be necessary to repeat this procedure if there is air in the system.

10. Engage safety props on both lift cylinders as follows:
 - a. Stop engine and remove key from ignition.
 - b. Pull lever (A) and rotate towards the header to release and lower safety prop (B) onto the lift cylinder.
 - c. Repeat for opposite lift cylinder.

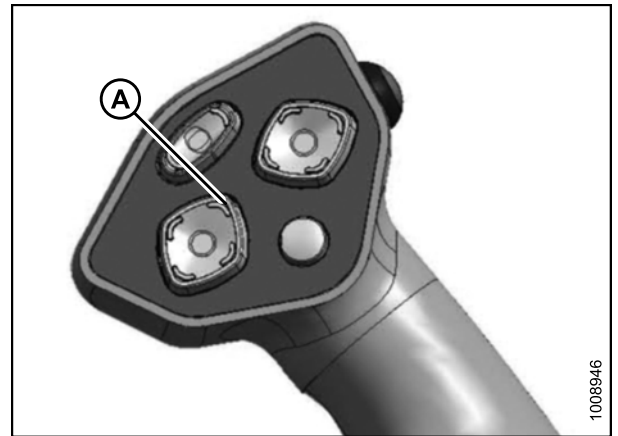

Figure 3.54: Ground Speed Lever

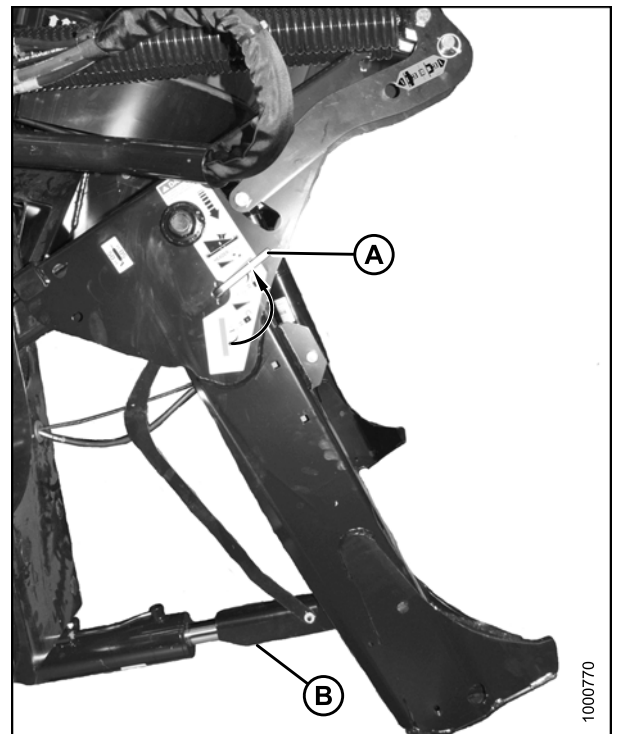

Figure 3.55: Safety Prop

ASSEMBLING THE HEADER

11. Install clevis pin (A) through boot and foot, and secure with hairpin (B). Repeat for opposite side.

IMPORTANT:

Ensure clevis pin (A) is fully inserted and hairpin is installed behind bracket.

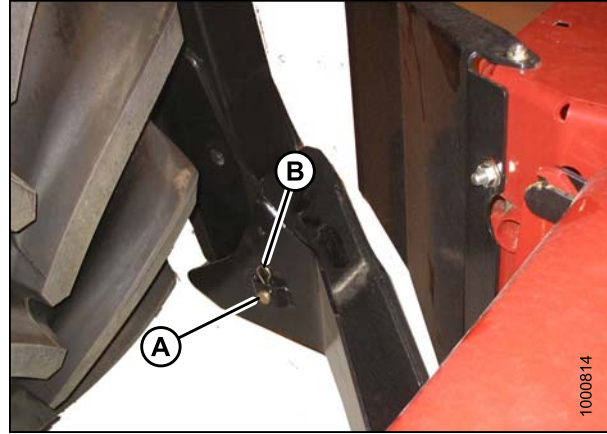

Figure 3.56: Header Boot

12. Remove clevis pin from storage position (B) in linkage and insert into hole (A) to engage float springs. Secure with hairpin.

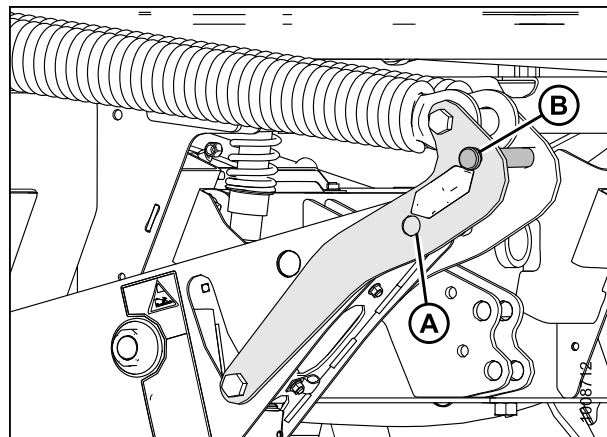

Figure 3.57: Header Float Linkage

13. Disengage safety prop by turning lever (A) downwards to release and lower stop until lever locks into vertical position.
14. Repeat for opposite safety prop.

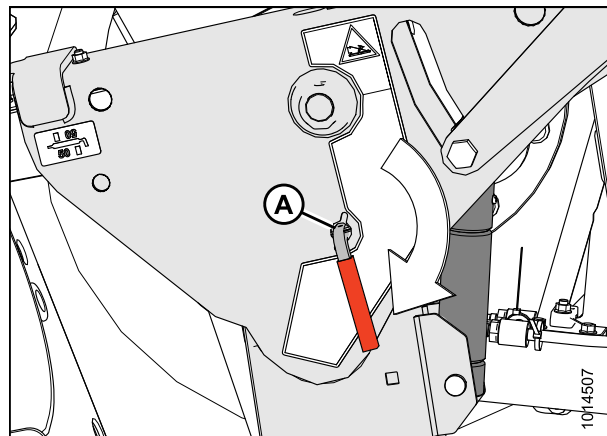

Figure 3.58: Safety Prop

ASSEMBLING THE HEADER

CAUTION

Check to be sure all bystanders have cleared the area.

15. Start the engine and activate the HEADER DOWN switch (A) on the GSL to fully lower the header.
16. Stop engine and remove key from ignition.

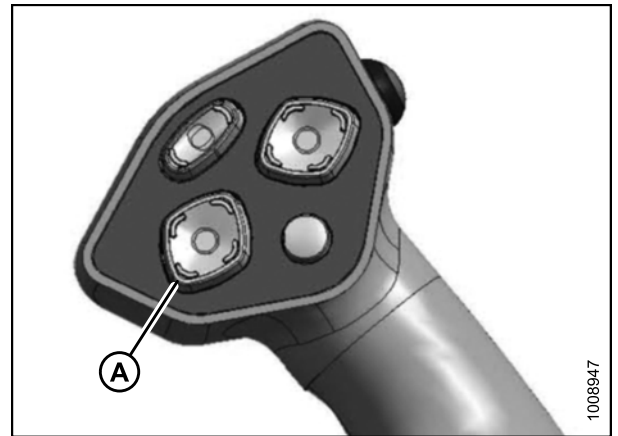

Figure 3.59: Ground Speed Lever

3.11.2 Attaching Header to an M200 or M205 Windrower: Hydraulic Center-Link without Self-Alignment

DANGER

To avoid bodily injury or death from unexpected startup of the machine, always stop the engine and remove the key from the ignition before leaving the operator's seat for any reason.

1. Remove hairpin (B) from clevis pin (A) and remove clevis pin from the header boots (C) on both sides of the header.

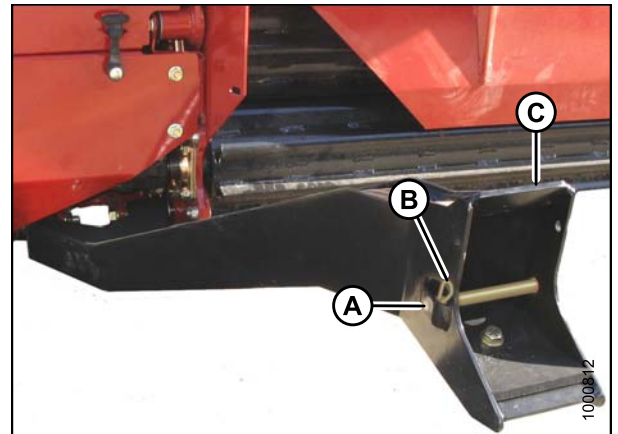

Figure 3.60: Header Boot

ASSEMBLING THE HEADER

CAUTION

To prevent damage to the lift system when lowering header lift linkages without a header or weight box attached to the windrower, ensure the float engagement pin is installed in storage position (B) and NOT in engaged position (A).

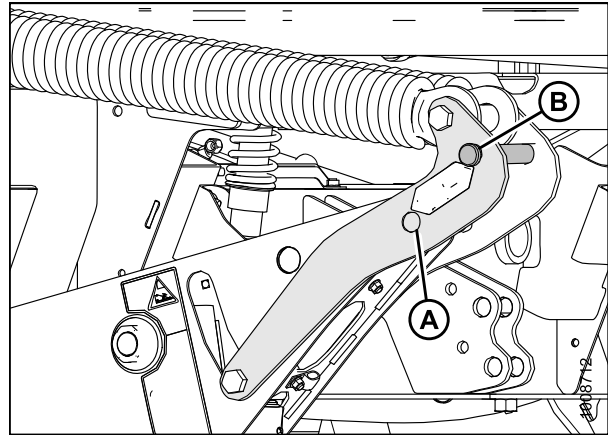

Figure 3.61: Header Float Linkage

CAUTION

Check to be sure all bystanders have cleared the area.

IMPORTANT:

Before starting engine, remove protective cover from exhaust stack.

2. Start the engine and activate the HEADER DOWN button (A) on the ground speed lever (GSL) to fully retract header lift cylinders.
3. Relocate pin (A) in frame linkage as required to raise the center-link (B) until the hook is above the attachment pin on the header.

IMPORTANT:

If the center-link is too low, it may contact the header as the windrower approaches the header for hookup.

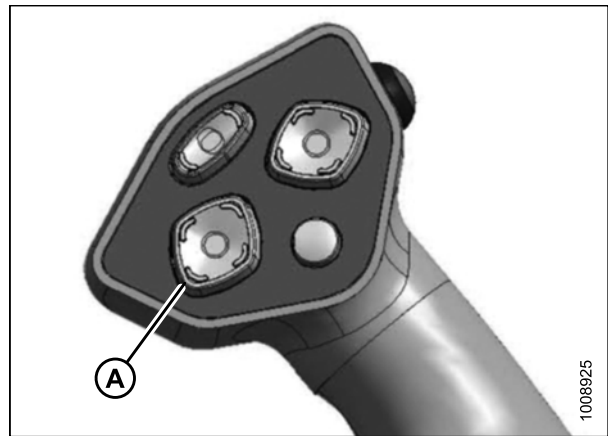

Figure 3.62: Ground Speed Lever

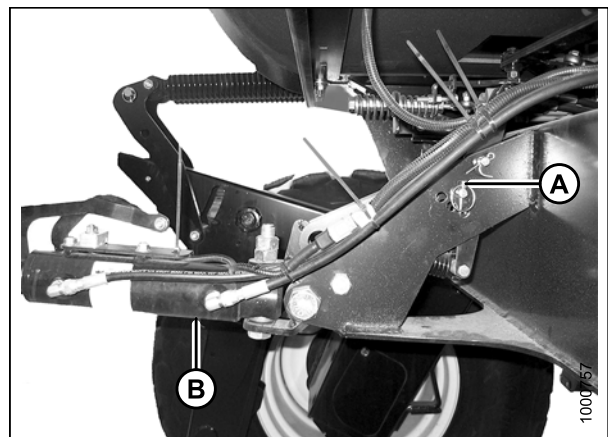

Figure 3.63: Hydraulic Center-Link

ASSEMBLING THE HEADER

4. Drive the windrower slowly forward until the windrower feet (A) enter the header boots (B). Continue driving slowly forward until the feet engage the boots and the header nudges forward.

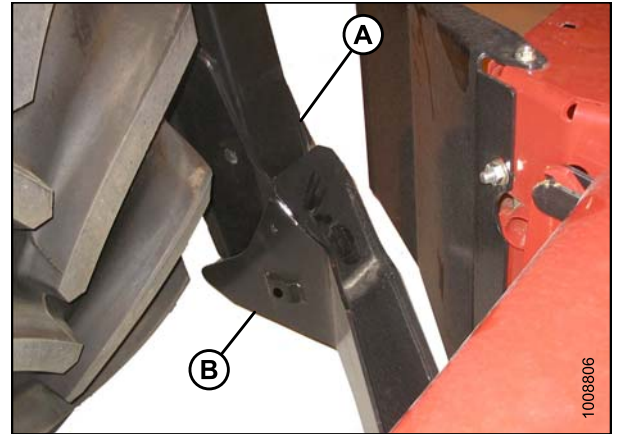

Figure 3.64: Header Boot

5. Use the following GSL functions to position the center-link hook above the header attachment pin:
 - Header tilt up (A) to retract the center-link
 - Header tilt down (B) to extend the center-link
6. Stop engine and remove key from ignition.

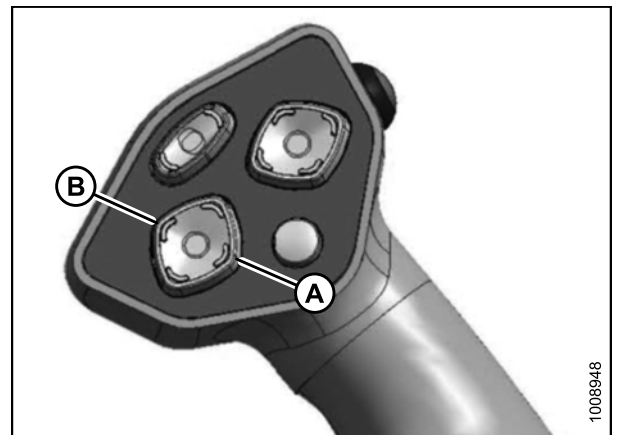

Figure 3.65: Ground Speed Lever

7. Push down on rod end of link cylinder (B) until hook engages and locks onto header pin.

IMPORTANT:

Hook release must be down to enable self-locking mechanism. If the release is open (up), manually push it down after hook engages header pin.

8. Check that center-link (A) is locked onto header by pulling upward on rod end (B) of cylinder.

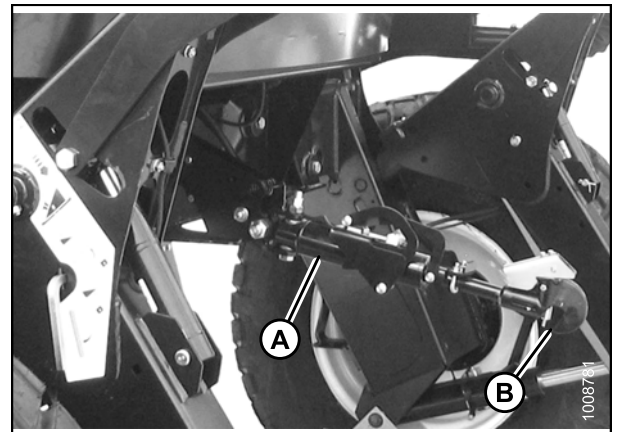

Figure 3.66: Hydraulic Center-Link

ASSEMBLING THE HEADER

CAUTION

Check to be sure all bystanders have cleared the area.

9. Start the engine.
10. Press the HEADER UP switch (A) to raise header to maximum height.

NOTE:

If one end of the header does **NOT** fully rise, rephase the lift cylinders as follows:

- a. Press and hold the HEADER UP switch until both cylinders stop moving.
- b. Continue to hold the switch for 3–4 seconds. Cylinders are now phased.

NOTE:

It may be necessary to repeat this procedure if there is air in the system.

11. Engage safety props on both lift cylinders as follows:
 - a. Stop engine and remove key from ignition.
 - b. Pull lever (A) and rotate towards the header to release and lower safety prop (B) onto the lift cylinder.
 - c. Repeat for opposite lift cylinder.

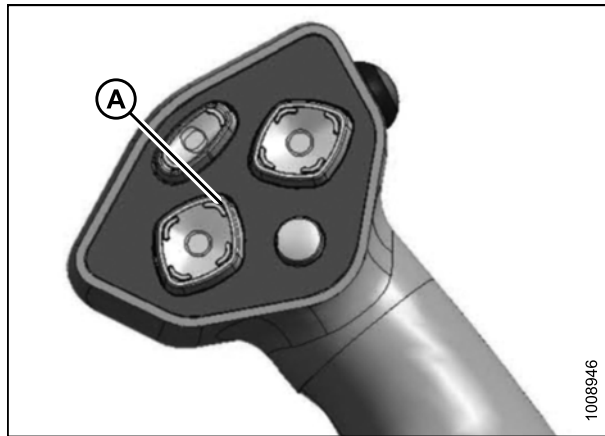

Figure 3.67: Ground Speed Lever

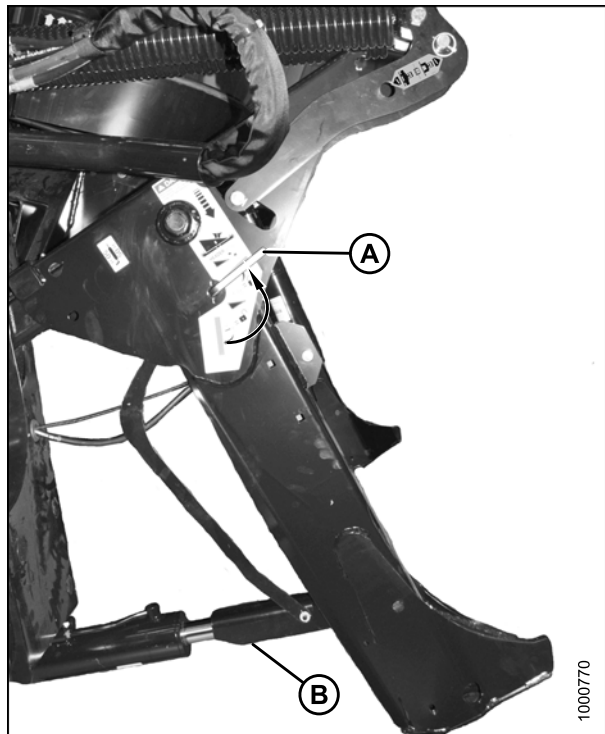

Figure 3.68: Safety Prop

ASSEMBLING THE HEADER

12. Install clevis pin (A) through boot and foot, and secure with hairpin (B). Repeat for opposite side.

IMPORTANT:

Ensure clevis pin (A) is fully inserted and hairpin is installed behind bracket.

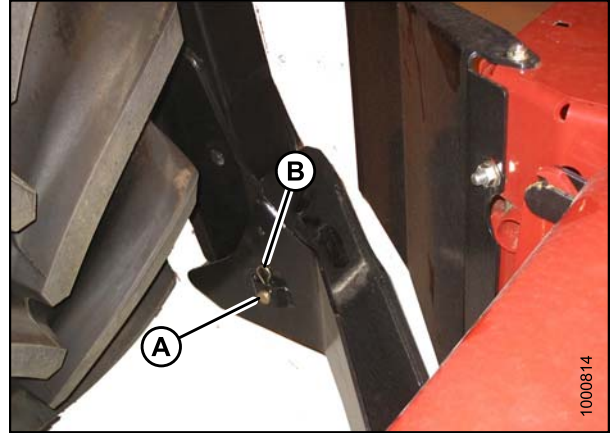

Figure 3.69: Header Boot

13. Remove clevis pin from storage position (B) in linkage and insert into hole (A) to engage float springs. Secure with hairpin.

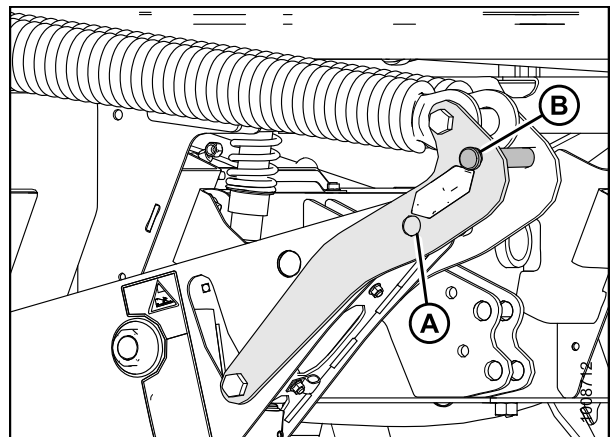

Figure 3.70: Header Float Linkage

14. Disengage safety prop by turning lever (A) downwards to release and lower stop until lever locks into vertical position.
15. Repeat for opposite safety prop.

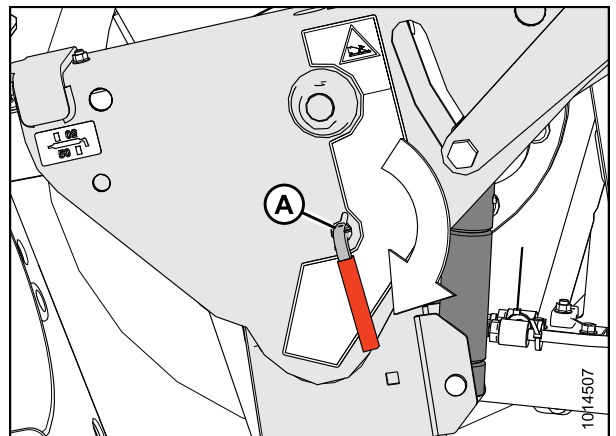

Figure 3.71: Safety Prop

ASSEMBLING THE HEADER

CAUTION

Check to be sure all bystanders have cleared the area.

16. Start the engine and activate the HEADER DOWN switch (A) on the GSL to fully lower the header.
17. Stop engine and remove key from ignition.

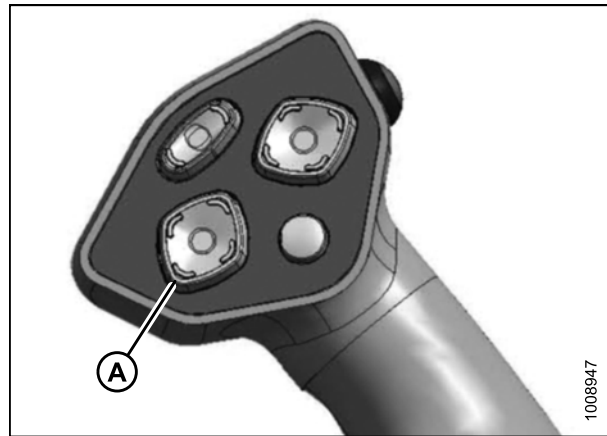

Figure 3.72: Ground Speed Lever

3.11.3 Attaching Header to an M200 Windrower: Mechanical Center-Link

DANGER

To avoid bodily injury or death from unexpected startup of the machine, always stop the engine and remove the key from the ignition before leaving the operator's seat for any reason.

1. Remove hairpin (B) from clevis pin (A) and remove clevis pin from the header boots (C) on both sides of the header.

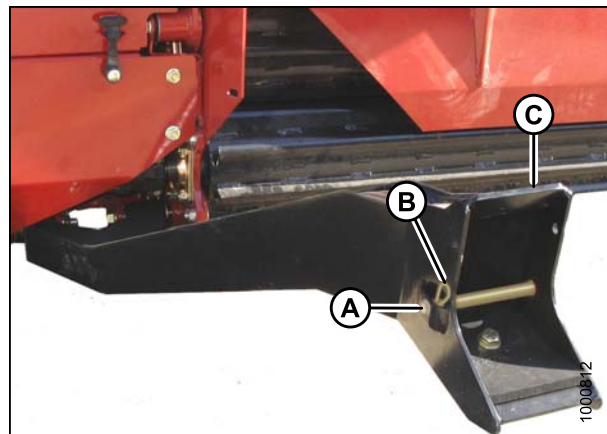

Figure 3.73: Header Boot

CAUTION

To prevent damage to the lift system when lowering header lift linkages without a header or weight box attached to the windrower, ensure the float engagement pin is installed in storage position (B) and NOT in engaged position (A).

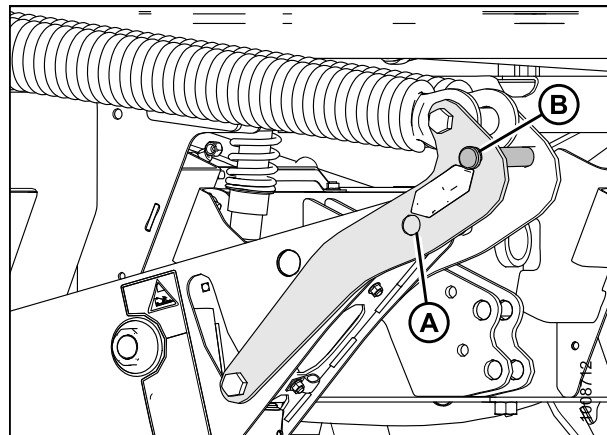

Figure 3.74: Header Float Linkage

ASSEMBLING THE HEADER

CAUTION

Check to be sure all bystanders have cleared the area.

IMPORTANT:

Before starting engine, remove protective cover from exhaust stack.

2. Start the engine and activate the HEADER DOWN button (A) on the ground speed lever (GSL) to fully retract header lift cylinders.

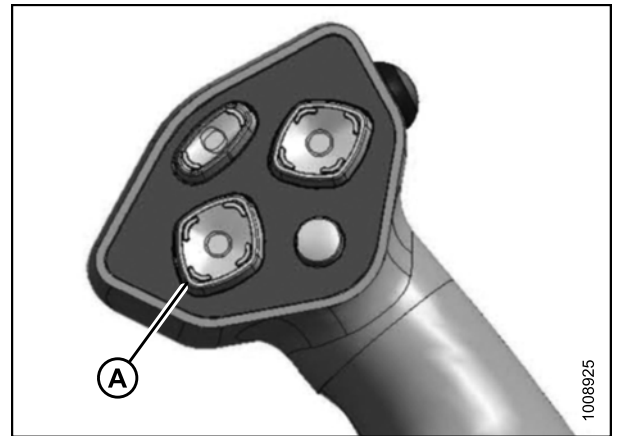

Figure 3.75: Ground Speed Lever

3. Drive the windrower slowly forward until the windrower feet (A) enter the header boots (B). Continue driving slowly forward until the feet engage the boots and the header nudges forward.

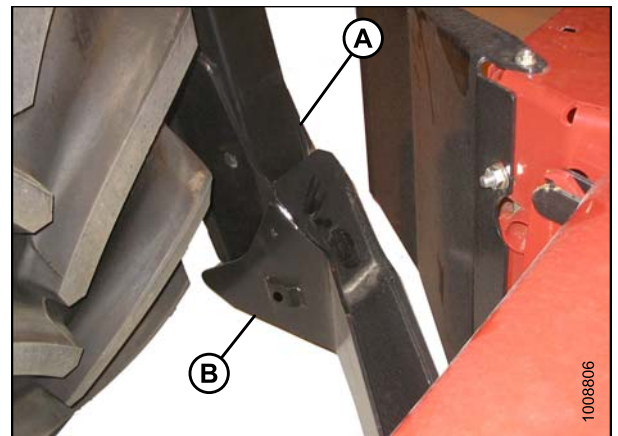

Figure 3.76: Header Boot

4. Stop engine and remove key from ignition.
5. Loosen nut (A) and rotate barrel (B) to adjust length until the link is aligned with the header bracket.
6. Install clevis pin (C) and secure with cotter pin (D).
7. Adjust length of link to achieve proper header angle by rotating barrel (B). Tighten nut (A) against barrel (a slight tap with a hammer is sufficient).

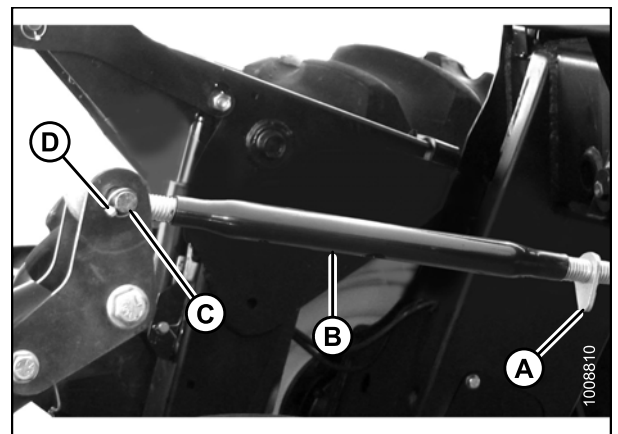

Figure 3.77: Mechanical Center-Link

ASSEMBLING THE HEADER

CAUTION

Check to be sure all bystanders have cleared the area.

8. Start the engine.
9. Press the HEADER UP switch (A) to raise header to maximum height.

NOTE:

If one end of the header does **NOT** fully rise, rephase the lift cylinders as follows:

- a. Press and hold the HEADER UP switch until both cylinders stop moving.
- b. Continue to hold the switch for 3–4 seconds. Cylinders are now phased.

NOTE:

It may be necessary to repeat this procedure if there is air in the system.

10. Engage safety props on both lift cylinders as follows:
 - a. Stop engine and remove key from ignition.
 - b. Pull lever (A) and rotate towards the header to release and lower safety prop (B) onto the lift cylinder.
 - c. Repeat for opposite lift cylinder.

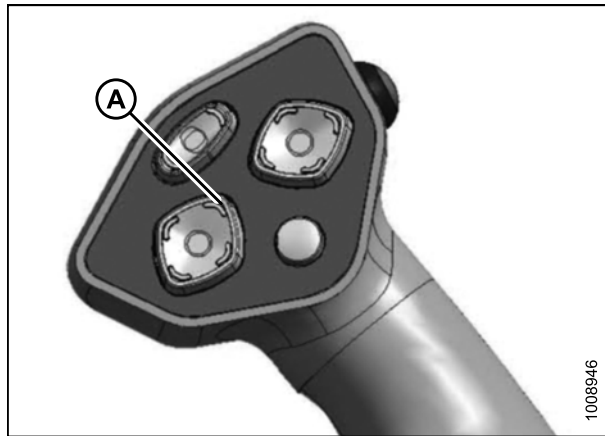

Figure 3.78: Ground Speed Lever

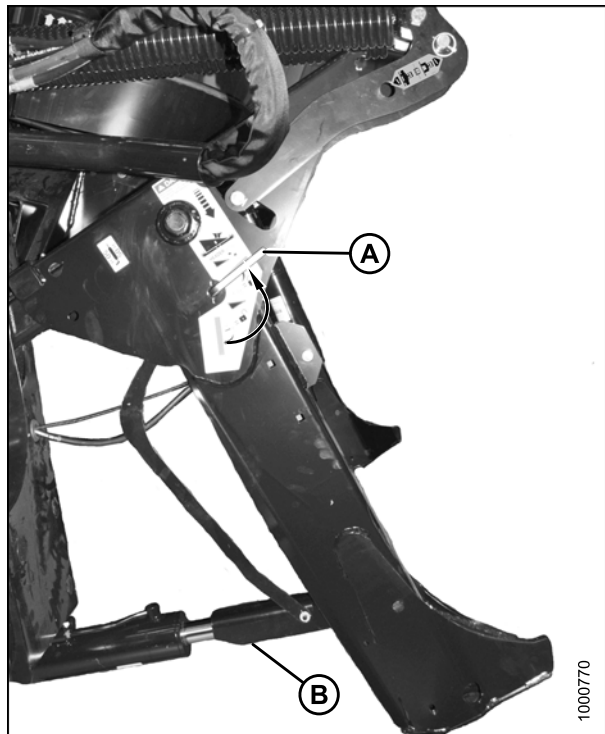

Figure 3.79: Safety Prop

ASSEMBLING THE HEADER

11. Install clevis pin (A) through boot and foot, and secure with hairpin (B). Repeat for opposite side.

IMPORTANT:

Ensure clevis pin (A) is fully inserted and hairpin is installed behind bracket.

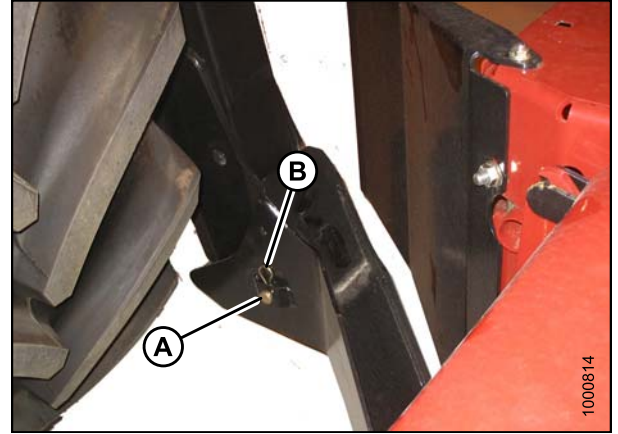

Figure 3.80: Header Boot

12. Remove clevis pin from storage position (B) in linkage and insert into hole (A) to engage float springs. Secure with hairpin.

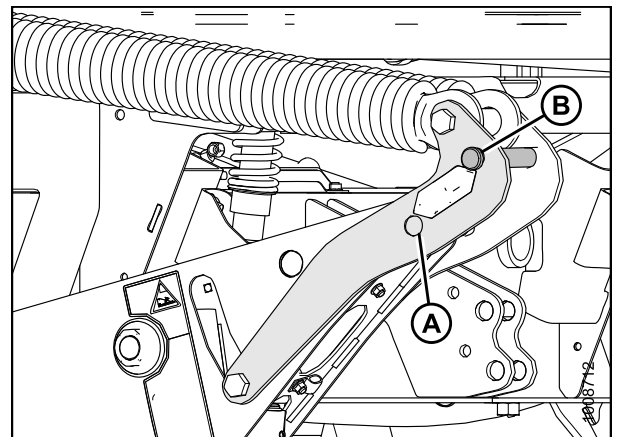

Figure 3.81: Header Float Linkage

13. Disengage safety prop by turning lever (A) downwards to release and lower stop until lever locks into vertical position.
14. Repeat for opposite safety prop.

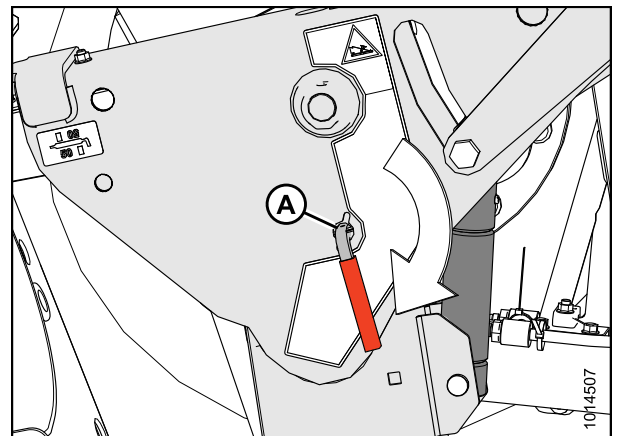

Figure 3.82: Safety Prop

ASSEMBLING THE HEADER

CAUTION

Check to be sure all bystanders have cleared the area.

15. Start the engine and activate the HEADER DOWN switch (A) on the GSL to fully lower the header.
16. Stop engine and remove key from ignition.

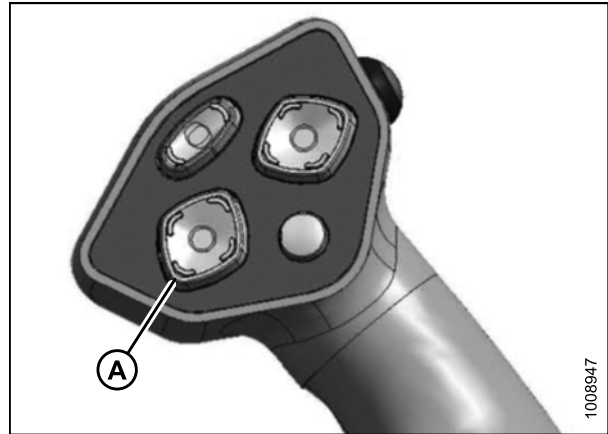

Figure 3.83: Ground Speed Lever

3.12 Attaching Header to an M1-Series Windrower

Follow the appropriate procedure:

- [3.12.1 Attaching Header to an M1240 Windrower: Hydraulic Center-Link with Optional Self-Alignment, page 45](#)
- [3.12.2 Attaching Header to an M1240 Windrower: Hydraulic Center-Link without Self-Alignment, page 50](#)

NOTE:

Refer to your windrower operator's manual for windrower operating instructions.

3.12.1 Attaching Header to an M1240 Windrower: Hydraulic Center-Link with Optional Self-Alignment

⚠ DANGER

To avoid bodily injury or death from unexpected startup of the machine, always stop the engine and remove the key from the ignition before leaving the operator's seat for any reason.

1. Remove hairpin (B) from clevis pin (A) and remove pin from header boot (C) on both sides of header.

⚠ CAUTION

Check to be sure all bystanders have cleared the area.

IMPORTANT:

Remove protective cover from exhaust stack prior to starting engine.

2. Start engine.

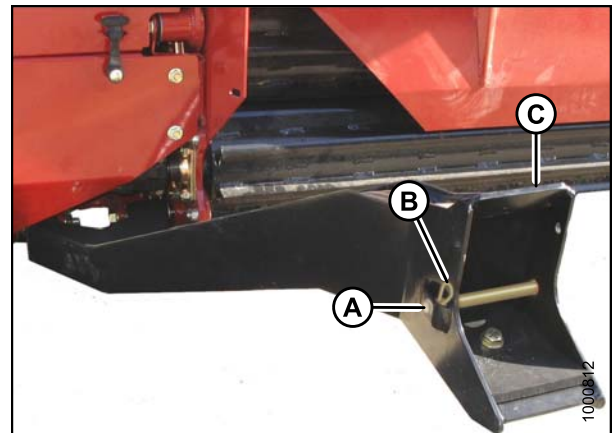

Figure 3.84: Header Boot

⚠ CAUTION

To prevent damage to the header lift linkages when lowering header lift legs without a header or weight box attached to the windrower, ensure the float springs tension is fully released.

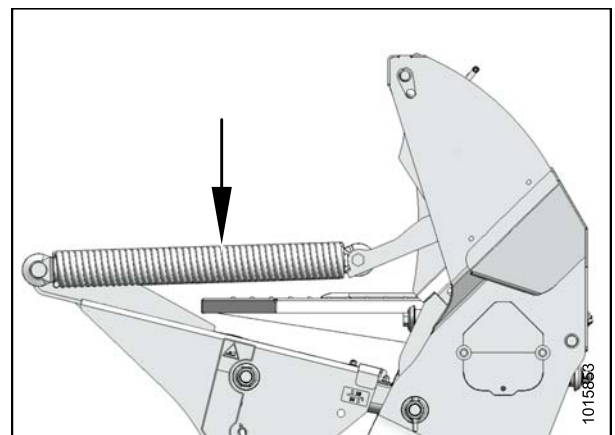

Figure 3.85: Header Float Spring

ASSEMBLING THE HEADER

NOTE:

If not prompted by the HPT display to remove header float, remove header float manually by doing the following:

3. Press rotary scroll knob (A) on Harvest Performance Tracker (HPT) to highlight QUICK MENU options.
4. Rotate scroll knob (A) to highlight the HEADER FLOAT symbol (B) and press scroll knob to select. Screen changes.



Figure 3.86: HPT Display

5. Press soft key 3 (A) to remove the header float.

NOTE:

If the header float is active, the icon at soft key 3 will say REMOVE FLOAT; if header float has been removed, the icon will say RESTORE FLOAT.



Figure 3.87: HPT Display

6. Press HEADER DOWN switch (A) on the ground speed lever (GSL) to fully retract header lift cylinders.
7. Press the REEL UP switch (A) on the GSL to raise the center-link until the hook is above the attachment pin on the header.

IMPORTANT:

If the center-link is too low, it may contact the header as the windrower approaches the header for hookup.

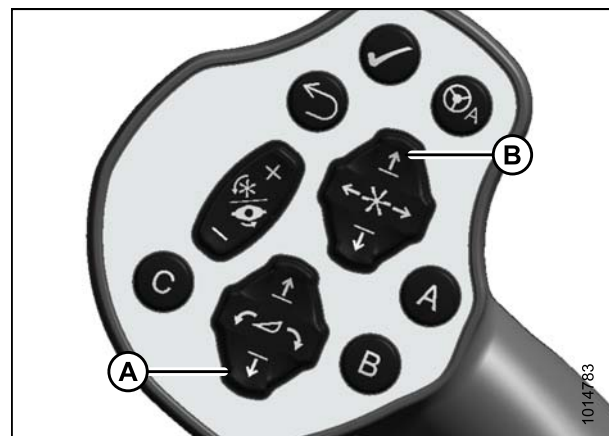

Figure 3.88: Ground Speed Lever

ASSEMBLING THE HEADER

8. Drive the windrower slowly forward until the windrower feet (A) enter the header boots (B). Continue to drive slowly forward until feet engage the boots and header nudges forward.
9. Ensure that lift linkages are properly engaged in header legs.

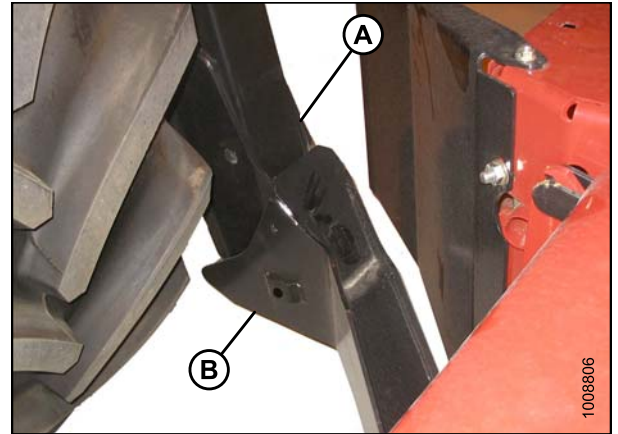

Figure 3.89: Header Boot

10. Adjust position of the center-link cylinder (A) with the switches on the GSL until the hook (B) is above the header attachment pin.

IMPORTANT:

Hook release (C) must be down to enable self-locking mechanism. If the release is open (up), manually push it down after hook engages header pin.

11. Lower center-link (A) onto the header with REEL DOWN switch on the GSL until it locks into position (hook release [C] is down).
12. Check that center-link is locked onto header by pressing the REEL UP switch on the GSL.

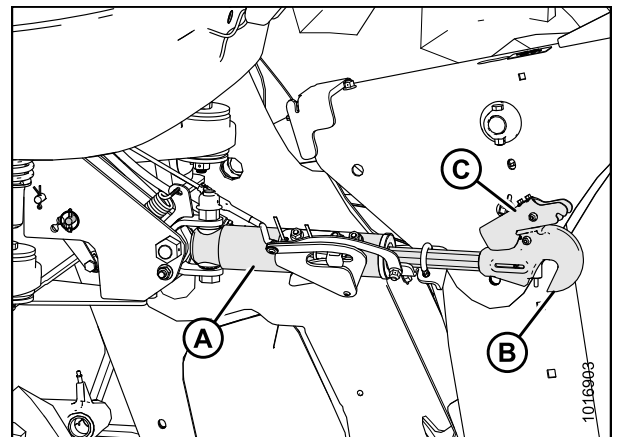

Figure 3.90: Center-Link

GSL switches:

- REEL DOWN (A) to lower the center-link
- REEL UP (B) to raise the center-link
- HEADER TILT DOWN (C) to extend the center-link
- HEADER TILT UP (D) to retract the center-link

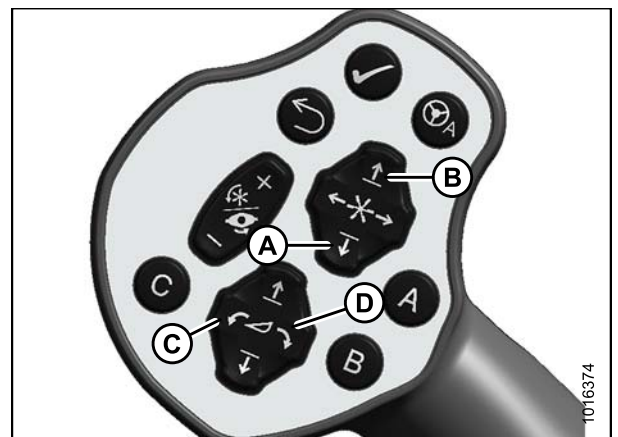

Figure 3.91: Ground Speed Lever

ASSEMBLING THE HEADER

CAUTION

Check to be sure all bystanders have cleared the area.

13. Press the HEADER UP switch (A) to raise header to maximum height.

NOTE:

If one end of the header does **NOT** fully raise, rephase the lift cylinders as follows:

- a. Press and hold the HEADER UP switch (A) until both cylinders stop moving.
- b. Continue to hold the switch for 3–4 seconds. Cylinders are now phased.

14. Stop engine, and remove the key.

15. Engage safety prop on lift cylinder as follows:

- a. Pull lever (A) and rotate toward header to release, and lower safety prop onto cylinder.
- b. Repeat for opposite lift cylinder.

IMPORTANT:

Ensure the safety props engage over cylinder piston rods. If safety prop does not engage properly, raise header until prop fits over the rod.

16. Install clevis pin (A) through boot and foot and secure with hairpin (B). Repeat for opposite side.

IMPORTANT:

Ensure clevis pin (A) is fully inserted and hairpin is installed behind bracket.



Figure 3.92: Ground Speed Lever

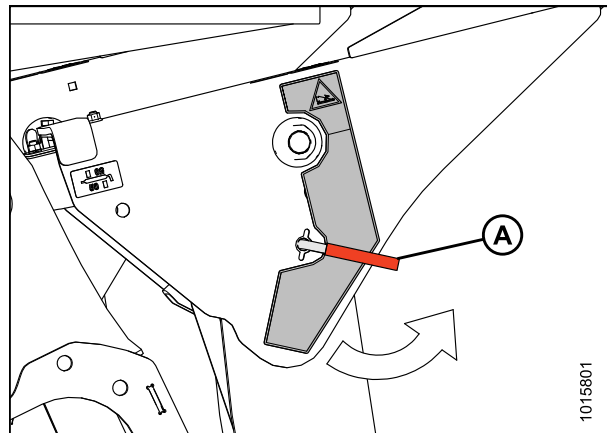

Figure 3.93: Cylinder Safety Prop

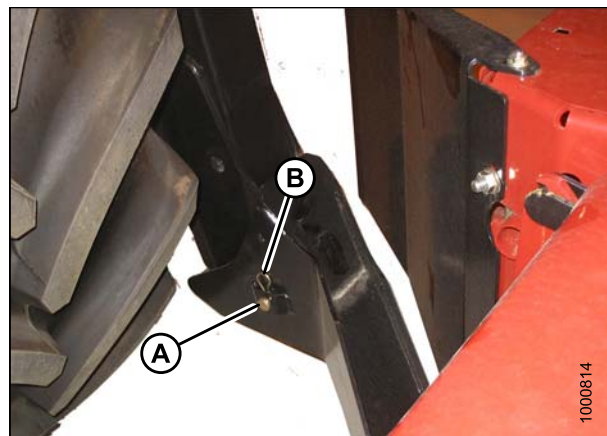

Figure 3.94: Header Boot

ASSEMBLING THE HEADER

17. Disengage safety prop by turning lever (A) downward to raise safety prop until lever locks into vertical position.

NOTE:

If safety prop will not disengage, raise header to release the prop.

18. Repeat for opposite side.

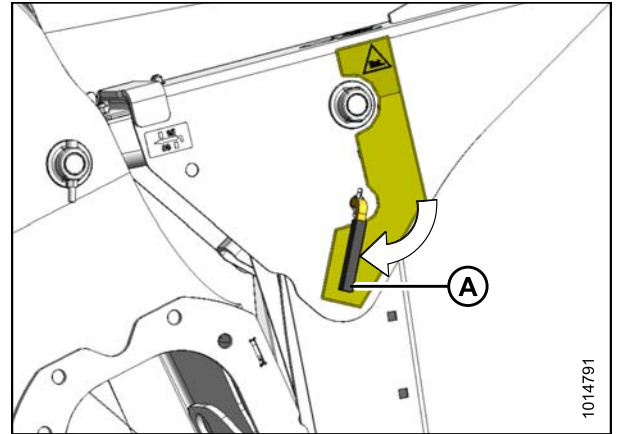

Figure 3.95: Cylinder Safety Prop

CAUTION

Check to be sure all bystanders have cleared the area.

19. Start engine and press HEADER DOWN switch (A) on GSL to fully lower header.

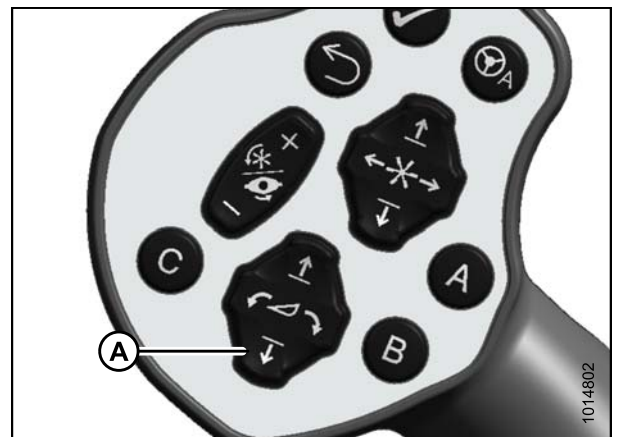

Figure 3.96: Ground Speed Lever

NOTE:

If not prompted by the HPT display to restore header float, restore header float manually by doing the following:

20. Press rotary scroll knob (A) on Harvest Performance Tracker (HPT) to highlight QUICK MENU options.
21. Rotate scroll knob (A) to highlight the HEADER FLOAT symbol (B) and press scroll knob to select. Screen changes.



Figure 3.97: HPT Display

ASSEMBLING THE HEADER

22. Press soft key 3 (A) to restore the header float.

NOTE:

If the header float is active, the icon at soft key 3 will say REMOVE FLOAT; if header float has been removed, the icon will say RESTORE FLOAT.



Figure 3.98: HPT Display

23. Stop engine, and remove key.

24. Proceed to [3.13.3 Attaching Hydraulics and Electrical: M1240 Windrowers, page 67](#).

3.12.2 Attaching Header to an M1240 Windrower: Hydraulic Center-Link without Self-Alignment

⚠ DANGER

To avoid bodily injury or death from unexpected startup of the machine, always stop the engine and remove the key from the ignition before leaving the operator's seat for any reason.

1. Relocate pin (A) in frame linkage as required to raise the center-link (B) until the hook is above the attachment pin on the header.

IMPORTANT:

If the center-link is too low, it may contact the header as the windrower approaches the header for hookup.

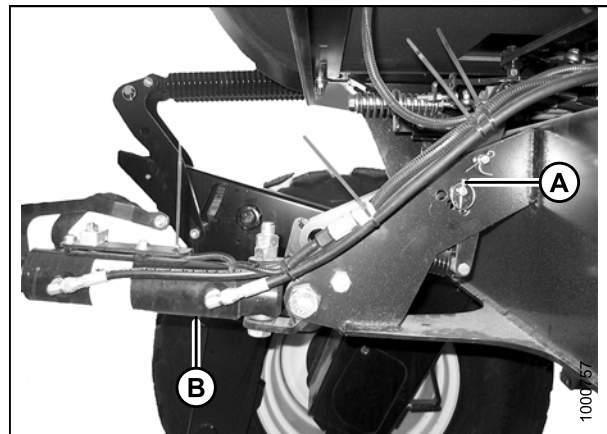

Figure 3.99: Hydraulic Center-Link without Self-Alignment Kit

ASSEMBLING THE HEADER

2. Remove hairpin (B) from clevis pin (A) and remove pin from header boots (C) on both sides of header.

CAUTION

Check to be sure all bystanders have cleared the area.

IMPORTANT:

Remove protective cover from exhaust stack prior to starting engine.

3. Start engine.

CAUTION

To prevent damage to the header lift linkages when lowering header lift legs without a header or weight box attached to the windrower, ensure the float springs tension is fully released.

NOTE:

If not prompted by the HPT display to remove header float, remove header float manually by doing the following:

4. Press rotary scroll knob (A) on Harvest Performance Tracker (HPT) to highlight QUICK MENU options.
5. Rotate scroll knob (A) to highlight the HEADER FLOAT symbol (B) and press scroll knob to select. Screen changes.

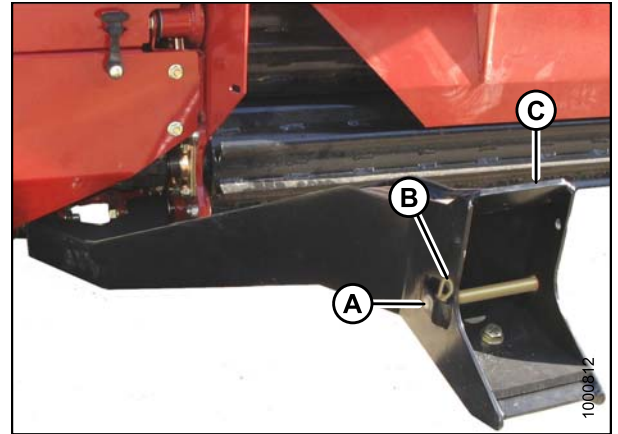

Figure 3.100: Header Boot

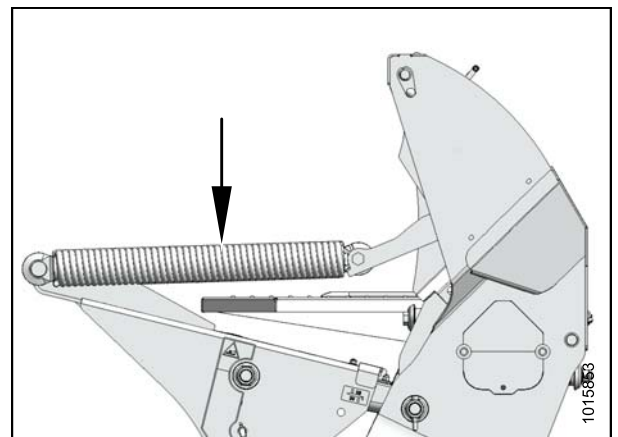

Figure 3.101: Header Float Spring



Figure 3.102: HPT Display

ASSEMBLING THE HEADER

- Press soft key 3 (A) to remove the header float.

NOTE:

If the header float is active, the icon at soft key 3 will say REMOVE FLOAT; if header float has been removed, the icon will say RESTORE FLOAT.



Figure 3.103: HPT Display

- Press HEADER DOWN button (A) on the ground speed lever (GSL) to fully retract header lift cylinders.

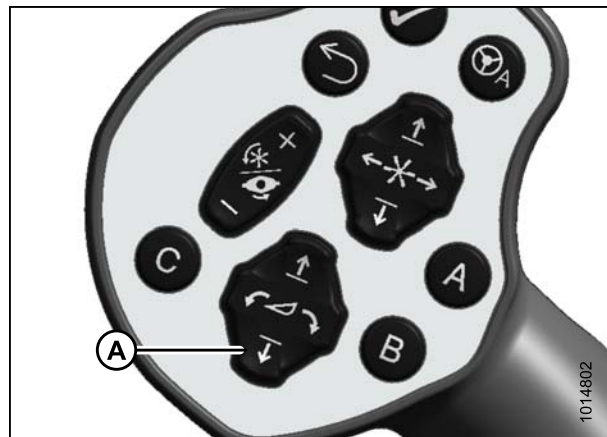

Figure 3.104: Ground Speed Lever

- Drive the windrower slowly forward until the windrower feet (A) enter the header boots (B). Continue to drive slowly forward until feet engage the boots and header nudges forward.
- Ensure that lift linkages are properly engaged in header legs.

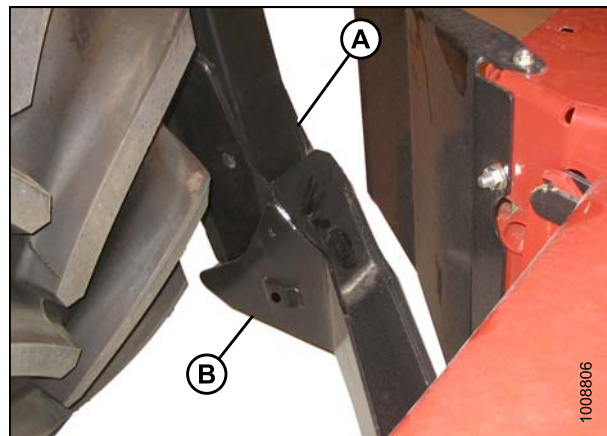

Figure 3.105: Header Boot

ASSEMBLING THE HEADER

10. Press HEADER TILT UP (A) and HEADER TILT DOWN (B) cylinder switches on the GSL to extend or retract center-link cylinder until the hook is aligned with the header attachment pin.
11. Stop engine and remove key from ignition.

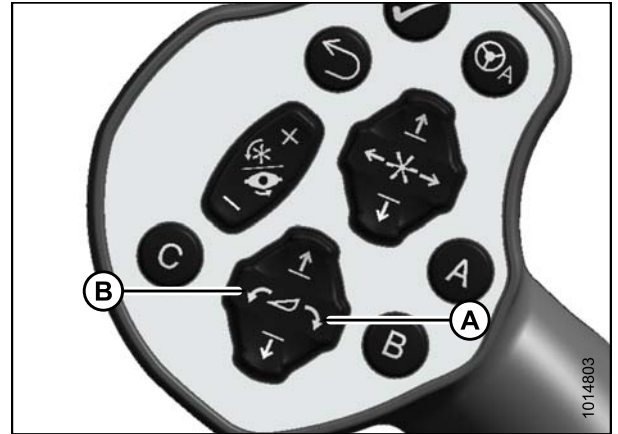

Figure 3.106: Ground Speed Lever

12. Push down on rod end of link cylinder (B) until hook engages and locks onto header pin.

IMPORTANT:

Hook release must be down to enable self-locking mechanism. If the release is open (up), manually push it down after hook engages header pin.

13. Check that center-link (A) is locked onto header by pulling upward on rod end (B) of cylinder.

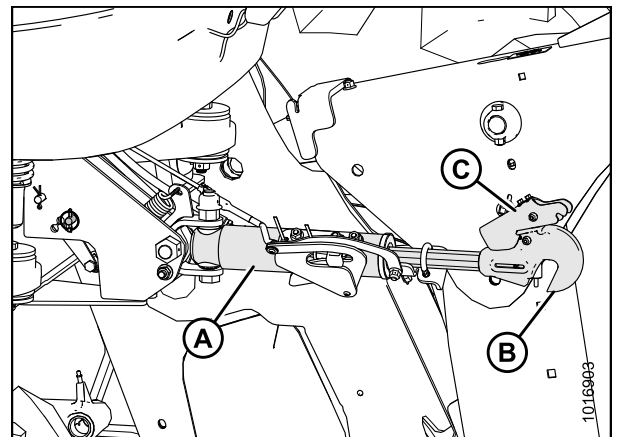

Figure 3.107: Center-Link

CAUTION

Check to be sure all bystanders have cleared the area.

14. Start engine and press the HEADER UP switch (A) to raise header to maximum height.

NOTE:

If one end of the header does **NOT** raise fully, rephase the cylinders as follows:

- a. Press and hold the HEADER UP switch (A) until both cylinders stop moving.
- b. Continue to hold the switch for 3–4 seconds. Cylinders are now phased.

15. Stop engine and remove the key from the ignition.



Figure 3.108: Ground Speed Lever

ASSEMBLING THE HEADER

16. Engage safety prop on lift cylinder as follows:
 - a. Pull lever (A) and rotate toward header to release, and lower safety prop onto cylinder.
 - b. Repeat for opposite lift cylinder.

IMPORTANT:

Ensure the safety props engage over cylinder piston rods. If safety prop does not engage properly, raise header until prop fits over the rod.

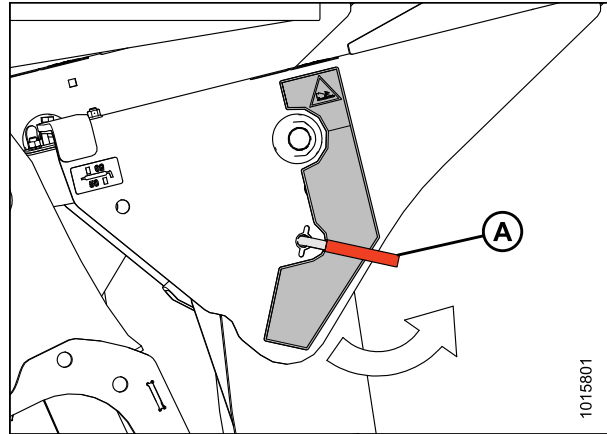

Figure 3.109: Cylinder Safety Prop

17. Install clevis pin (A) through boot and foot and secure with hairpin (B). Repeat for opposite side.

IMPORTANT:

Ensure clevis pin (A) is fully inserted and hairpin is installed behind bracket.

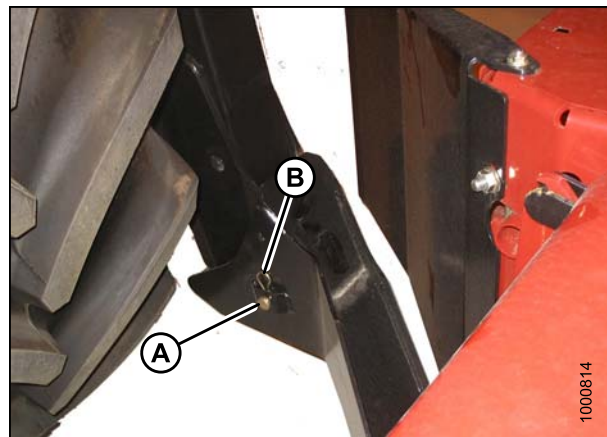

Figure 3.110: Header Boot

18. Disengage safety prop by turning lever (A) downward to raise safety prop until lever locks into vertical position.

NOTE:

If safety prop will not disengage, raise header to release the prop.

19. Repeat for opposite side.

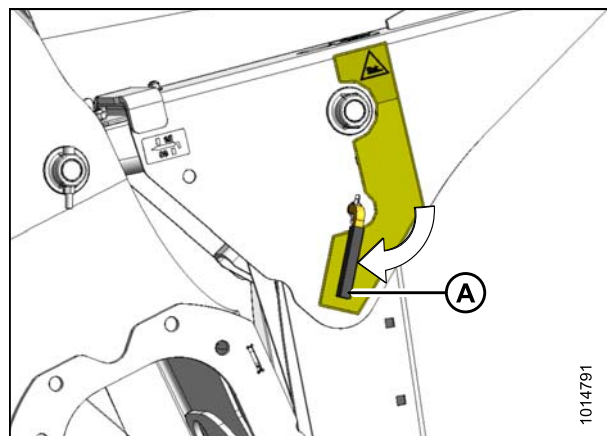

Figure 3.111: Cylinder Safety Prop

ASSEMBLING THE HEADER

CAUTION

Check to be sure all bystanders have cleared the area.

20. Start engine and press HEADER DOWN switch (A) on GSL to fully lower header.

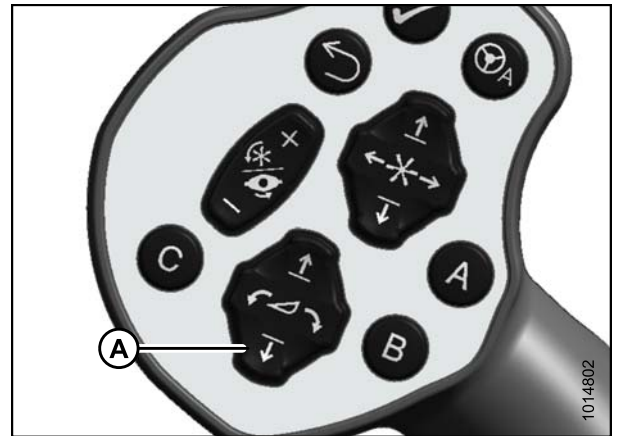

Figure 3.112: Ground Speed Lever

NOTE:

If not prompted by the HPT display to restore float, restore float manually by doing the following:

21. Press rotary scroll knob (A) on Harvest Performance Tracker (HPT) to highlight QUICK MENU options.
22. Rotate scroll knob (A) to highlight the HEADER FLOAT symbol (B) and press to select. Screen changes.

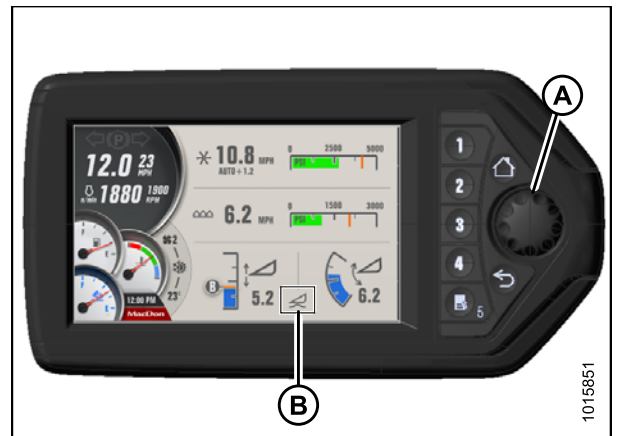

Figure 3.113: HPT Display

23. Press soft key 3 (A) to restore the header float.

NOTE:

If the header float is active, the icon at soft key 3 will say REMOVE FLOAT; if header float has been removed, the icon will say RESTORE FLOAT.



Figure 3.114: HPT Display

24. Stop engine, and remove key.
25. Proceed to [3.13.3 Attaching Hydraulics and Electrical: M1240 Windrowers, page 67](#).

3.13 Attaching Hydraulic and Electrical Connections

The procedure for attaching the header hydraulic and electrical connections depends on the windrower model. Refer to the appropriate procedure:

- [3.13.1 Attaching Hydraulics and Electrical: M205 Windrowers, page 56](#)
- [3.13.2 Attaching Hydraulics and Electrical: M200 Windrowers, page 61](#)
- [3.13.3 Attaching Hydraulics and Electrical: M1240 Windrowers, page 67](#)

3.13.1 Attaching Hydraulics and Electrical: M205 Windrowers

DANGER

To avoid bodily injury or death from unexpected startup of the machine, always stop the engine and remove the key from the ignition before leaving the operator's seat for any reason.

1. Move windrower left-hand (cab-forward) platform (A) to OPEN position.

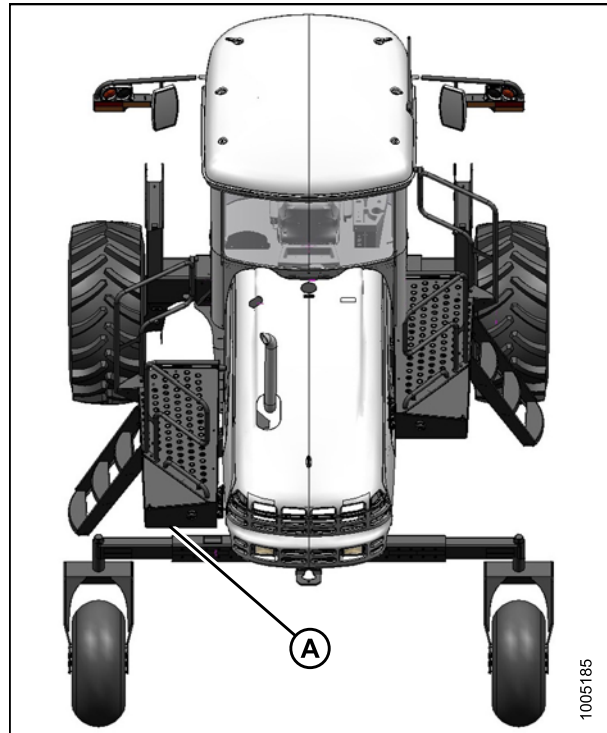

Figure 3.115: Windrower with LH Platform in Open Position

ASSEMBLING THE HEADER

2. Route the hose bundle (A) from the header, under the windrower frame, and insert pin (B) into hole in windrower frame.
3. Place hoses on support (C) and on the hose support on the forming shield (not shown).
4. If optional couplers and lock are installed on hoses and lines, proceed as follows. Otherwise, proceed to Step 13., page 60.

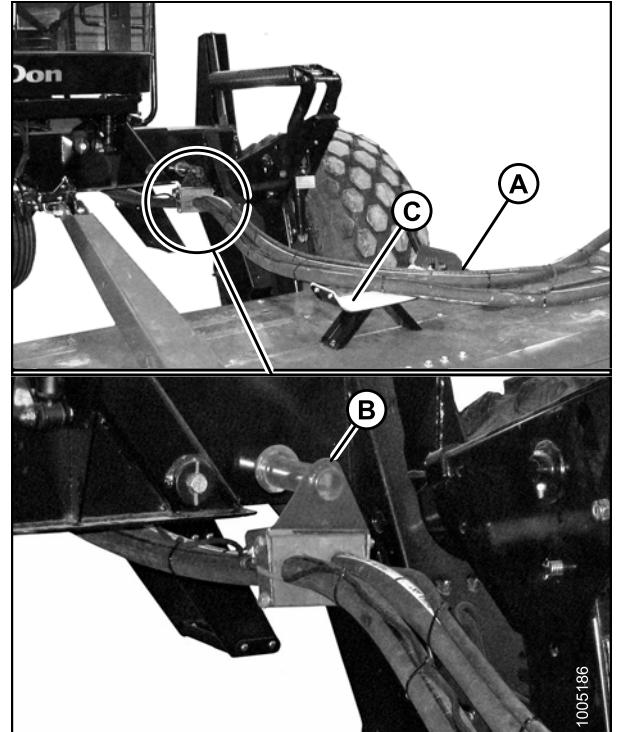

Figure 3.116: Hydraulic Hoses

5. Remove coupler lock as follows:
 - a. Remove lynch pin (A) and open up coupler lock (B).
 - b. Remove lock from coupler.

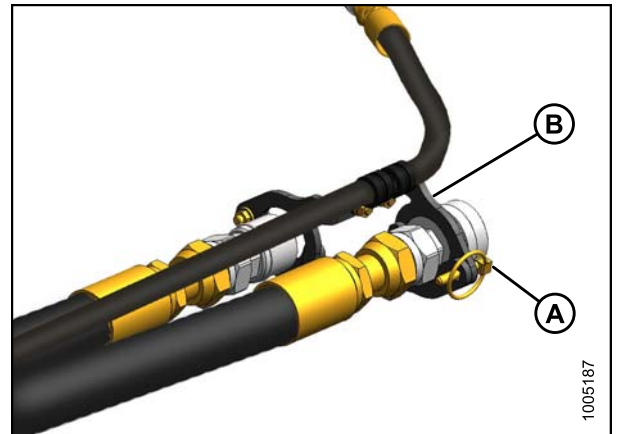

Figure 3.117: Hydraulic Couplers with Coupler Lock

ASSEMBLING THE HEADER

6. Connect the rear pump hose (A) to outboard line (D) on windrower using coupler (C).
7. Connect the front pump hose (B) to the inboard line (E) on windrower using coupler (C).

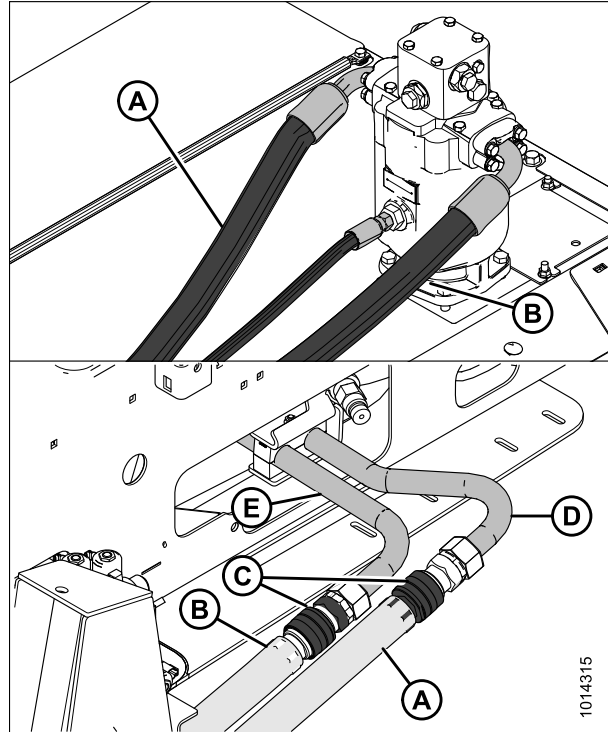

Figure 3.118: Hose Routing and Connections

8. Position the lock onto the couplers so that retainer (A) rests under the fitting next to the sleeve on each coupler.

NOTE:

The retainer can be adjusted by loosening bolts (B). Tighten bolts after adjusting.

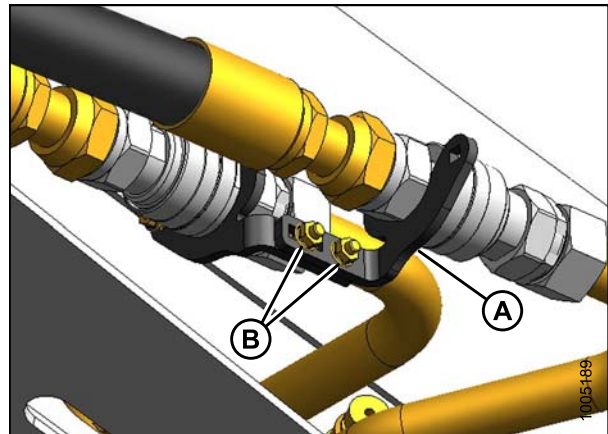

Figure 3.119: Hydraulic Couplers with Coupler Lock

ASSEMBLING THE HEADER

- Lower holder (A) onto sleeves (B) so that the flats are positioned on the holder.

NOTE:

Holder can be adjusted by loosening bolts (C).
Tighten bolts after adjusting.

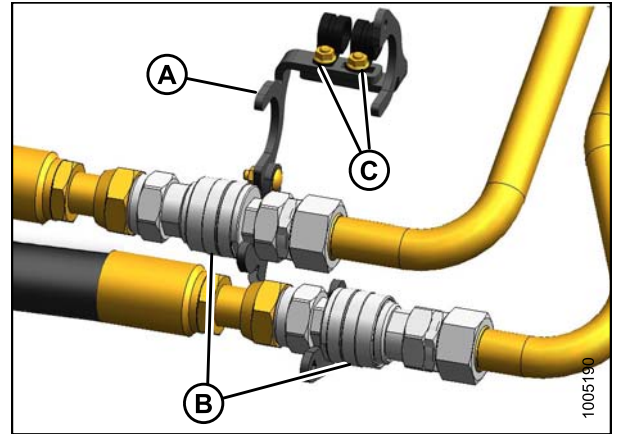

Figure 3.120: Hydraulic Couplers with Coupler Lock

- Insert lynch pin (A) to secure the lock.
- Attach case drain hose coupler at (B).
- Proceed to Step [17.](#), [page 60.](#)

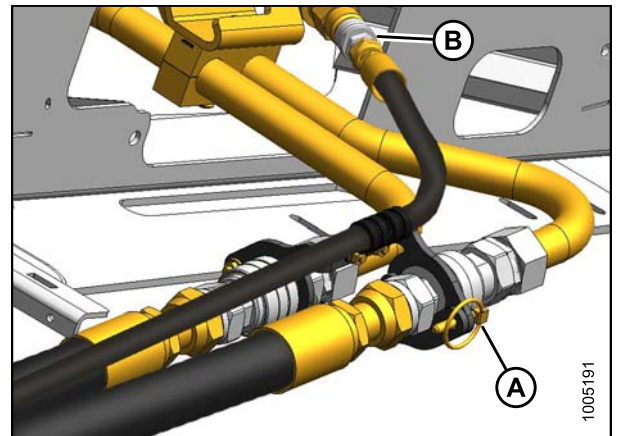

Figure 3.121: Hydraulic Couplers with Case Drain Hose

ASSEMBLING THE HEADER

13. Connect the rear pump hose (A) to outboard line (F) on windrower using fitting (D).
14. Connect the front pump hose (B) to the inboard line (G) on windrower using fitting (D).
15. Torque fittings to 183 N·m (135 ft·lbf).
16. Attach case drain hose and coupler (C) to (E).

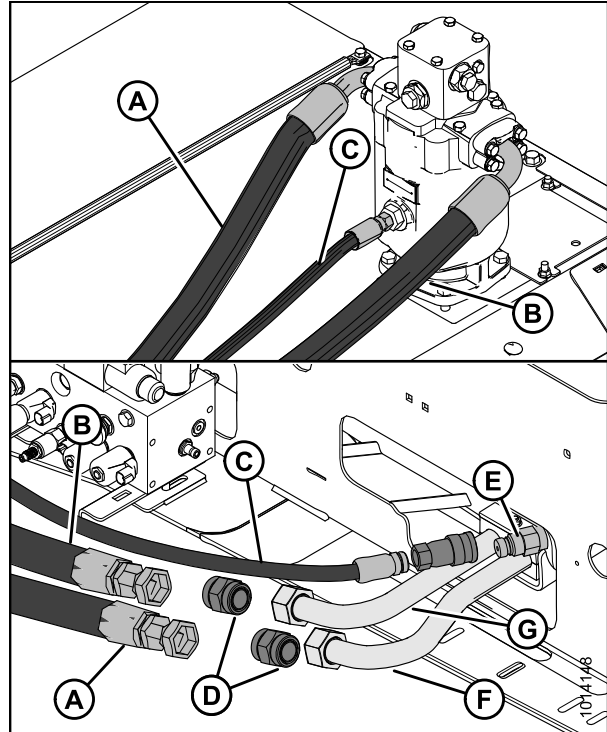

Figure 3.122: Hose Routing and Connections

17. Connect the electrical harness to connector HC-2A (A) (located beside the forward valve block on the windrower).

NOTE:

Valve block hidden to show the electrical connector.

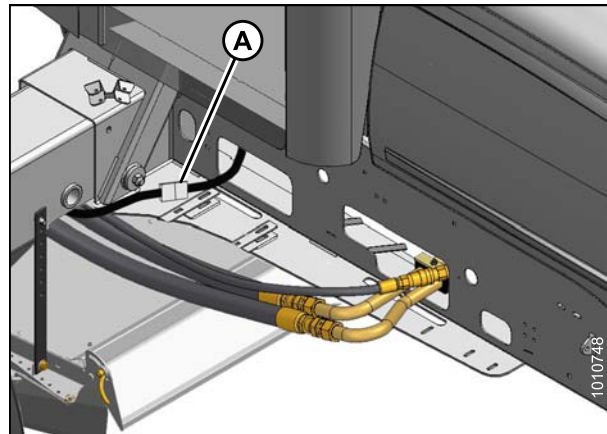

Figure 3.123: Electrical Connection

ASSEMBLING THE HEADER

18. Move the windrower platform (A) to the CLOSED position.

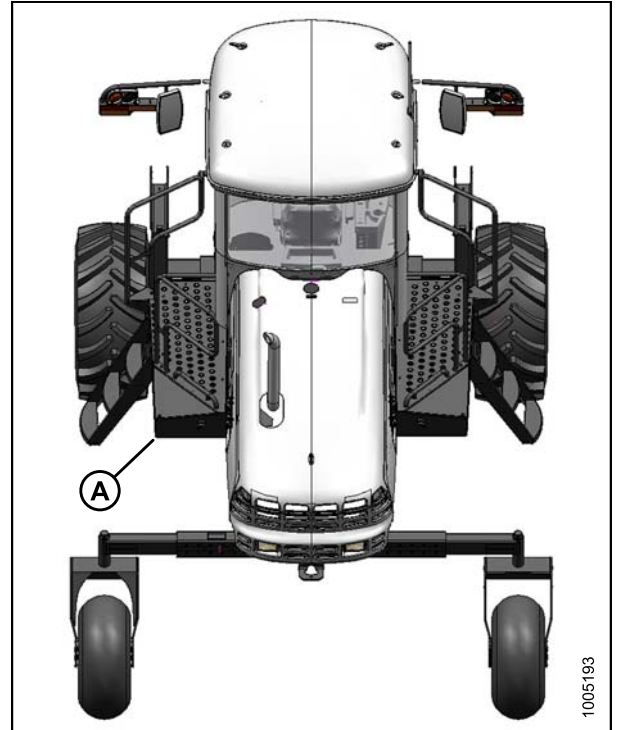

Figure 3.124: Windrower with LH Platform in Closed Position

3.13.2 Attaching Hydraulics and Electrical: M200 Windrowers

DANGER

To avoid bodily injury or death from unexpected startup of the machine, always stop the engine and remove the key from the ignition before leaving the operator's seat for any reason.

To operate the 16-foot header on an M200 windrower, installation of a motor/hose kit (MD #B5455) is required.

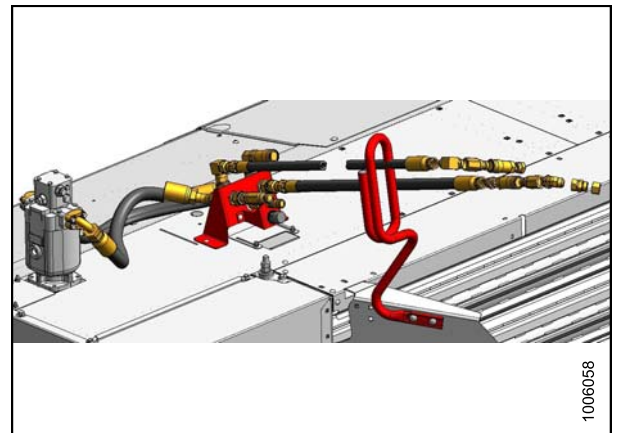

Figure 3.125: MD #B5455

ASSEMBLING THE HEADER

1. Disengage and rotate lever (A) counterclockwise to the UP position.
2. Remove the cap (B) securing the electrical connector to the frame.

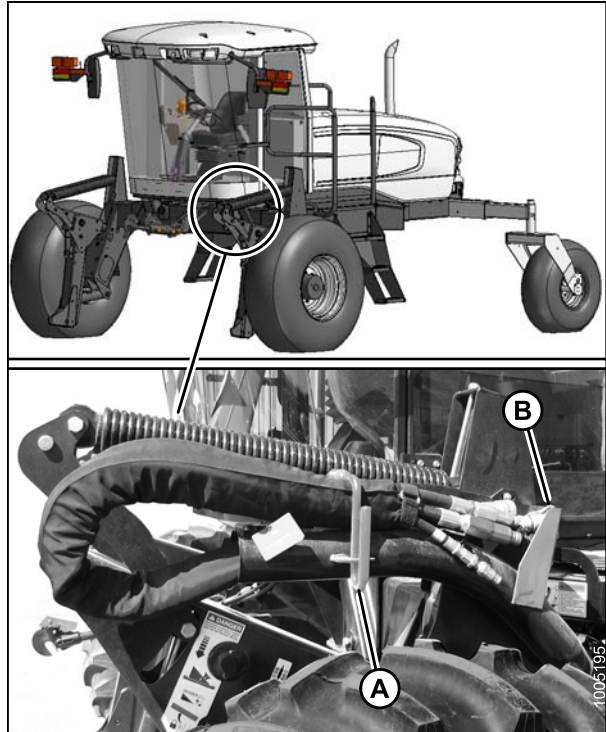

Figure 3.126: Hose Bundle

3. Move hose bundle (A) from the windrower and rest the bundle on the header.

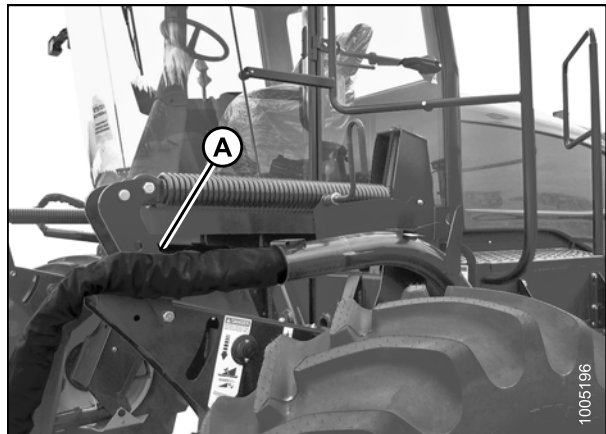

Figure 3.127: Hose Bundle

ASSEMBLING THE HEADER

4. Position the hose support with the lower bolt (A) in the forward hole, as shown. Loosen both bolts and adjust as required.

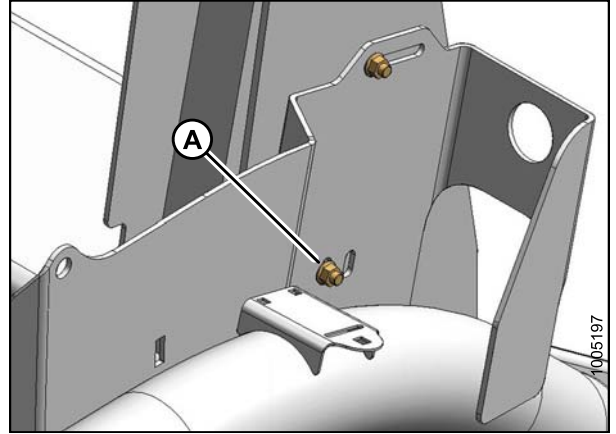

Figure 3.128: Hose Support

5. Route hose bundle (A) from the windrower through the support (B) on header.
6. Route header return and pressure hose bundle (C) through support (B) on header to the windrower.

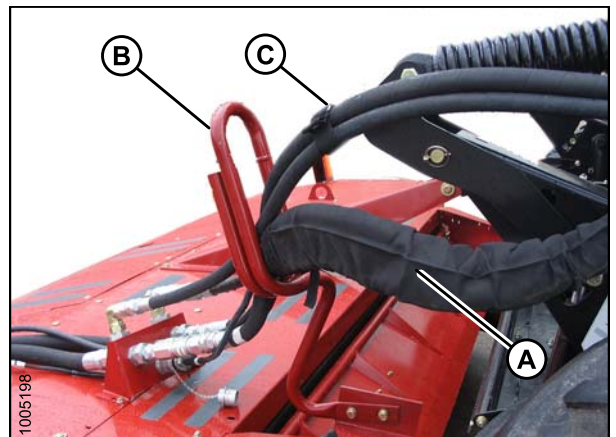

Figure 3.129: Hose Bundle

7. Secure hose bundles with three cinch straps (B).
8. Lower and lock lever (A).

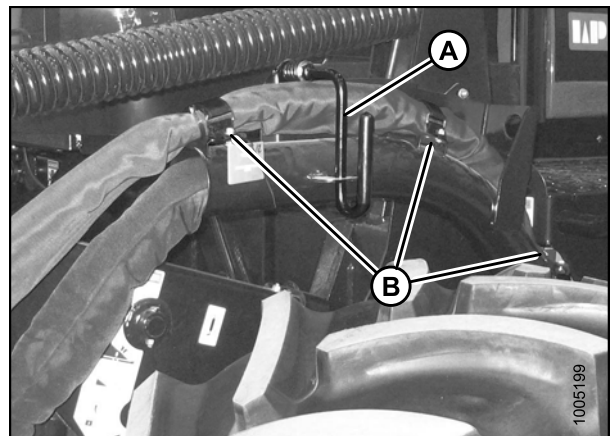

Figure 3.130: Hose Bundle

ASSEMBLING THE HEADER

9. Move the windrower's left-hand side (cab-forward) platform (A) to the OPEN position to access the valve blocks.

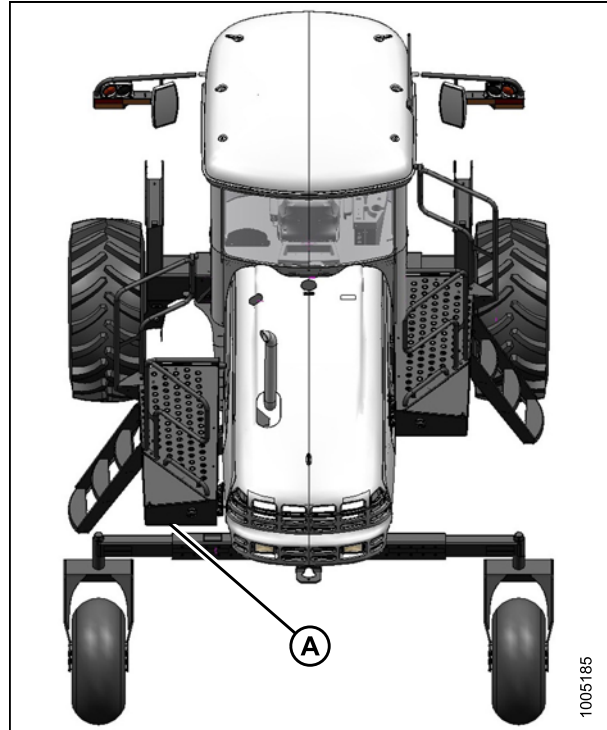

Figure 3.131: Windrower with LH Platform in Open Position

10. Remove caps from pressure (A) and return (B) ports on valve (C) and discard.

IMPORTANT:

Keep open lines and ports clean.

11. Remove fitting at pressure port (A) and discard.

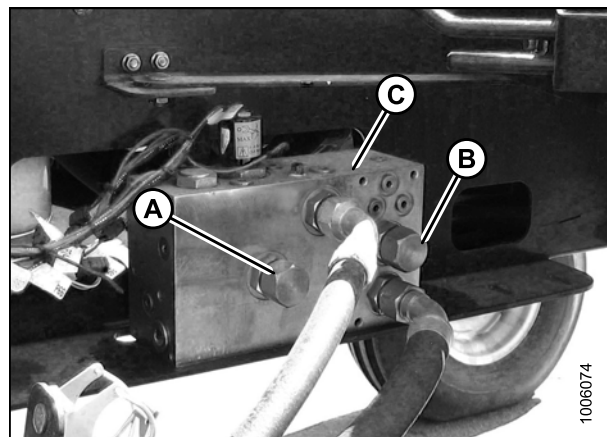

Figure 3.132: Hydraulic Connections

ASSEMBLING THE HEADER

12. Disconnect fittings at end of hose bundle (A). Discard caps.

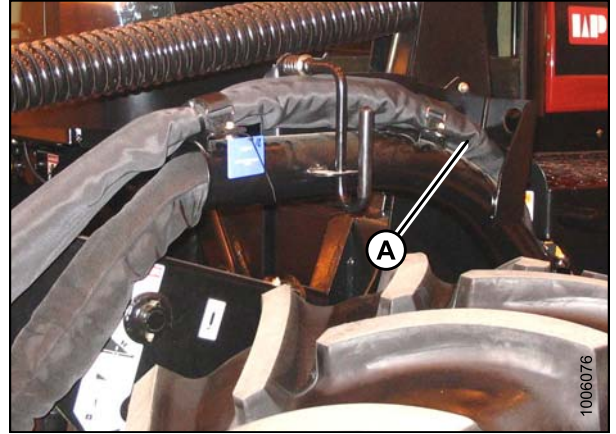

Figure 3.133: Hose Bundle

13. Remove O-ring (A) from cap and install over JIC threads on fitting at return port (B).
14. Install female coupler (C) from hose in return port (B).
15. Install male 45° fitting (D) and male coupler (E) from hose in pressure port (F).

NOTE:

Male fitting and coupler may need to be disassembled prior to installing on valve block.

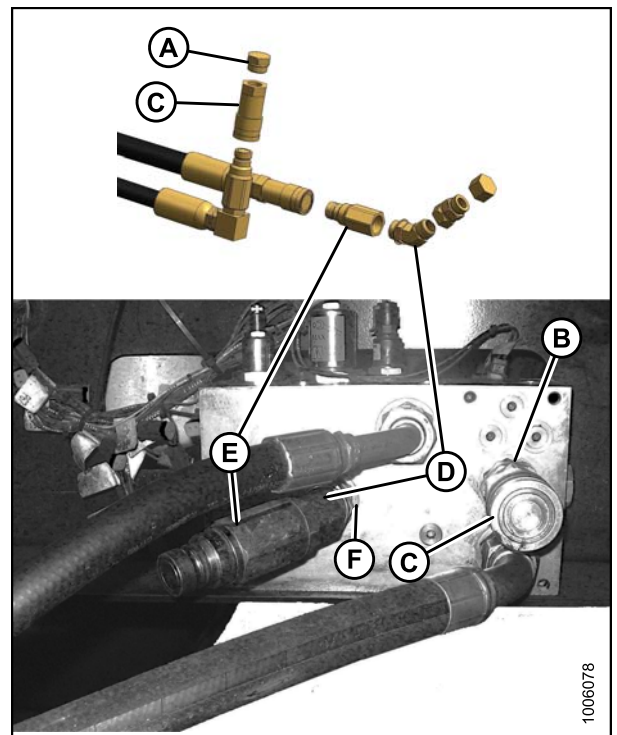

Figure 3.134: Hydraulic Connections

ASSEMBLING THE HEADER

16. Connect hoses from header to fittings as shown.

NOTE:

Some windrowers maybe equipped with a reverser. The return line (C) would require a 45° fitting instead of a 90° fitting to avoid contact with the platform.

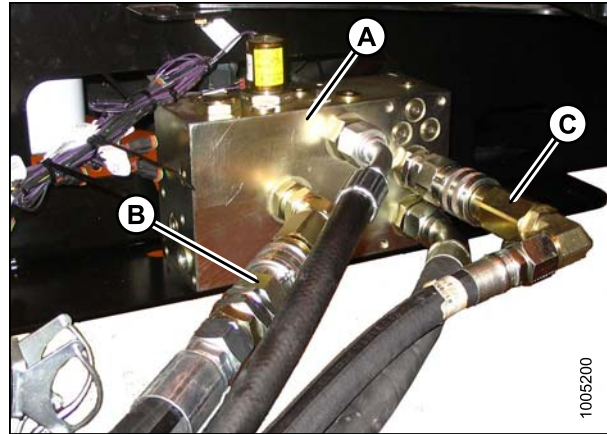

Figure 3.135: Hydraulic Connections

A - Middle Valve Block
C - Return

B - Pressure

17. Remove caps and plugs from hoses and lines.

18. Connect the pressure (A), return (B), and case drain (C) hoses from windrower to fittings on header as shown.

19. Connect electrical harness (D) from windrower to connector on header.

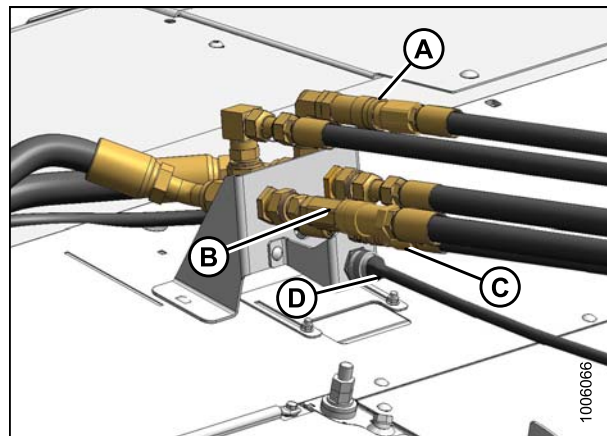

Figure 3.136: Header Connections

ASSEMBLING THE HEADER

20. Move platform (A) to the CLOSED position.

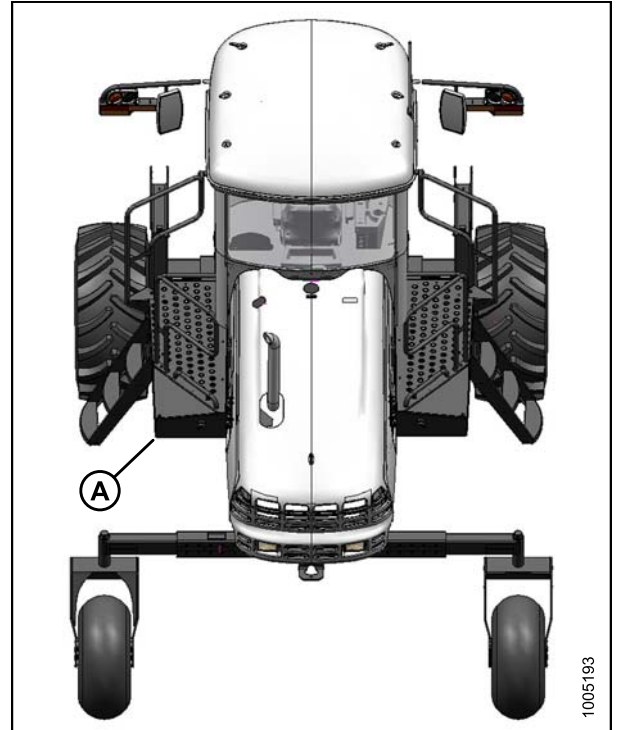

Figure 3.137: Top View of Windrower

3.13.3 Attaching Hydraulics and Electrical: M1240 Windrowers

1. Approach platform/stair unit (A) on left cab-forward side of windrower and ensure cab door is closed.
2. Push latch (B), and pull platform (A) toward walking beam until it stops and latch engages.

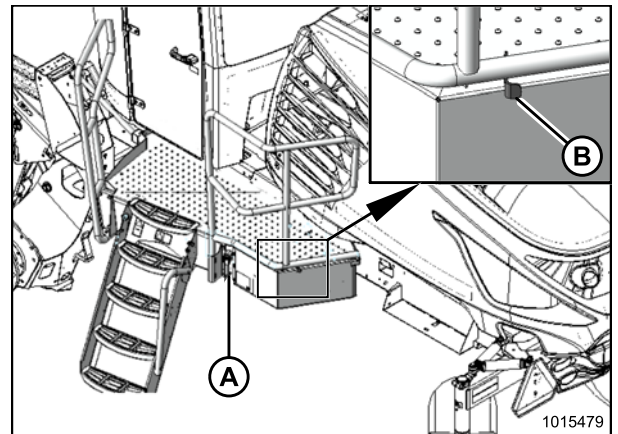

Figure 3.138: Left Cab-Forward Platform

ASSEMBLING THE HEADER

- Retrieve hydraulic hoses from header, and route to left cab-forward side of windrower.

NOTE:

Route hoses as straight as possible and avoid rub/wear points that could damage hydraulic hoses.

- Use a clean rag to remove dirt and moisture from the couplers.
- Make the following hydraulic and electrical connections to the windrower:
 - Connect the disc pressure hose to receptacle (A)
 - Connect the disc return hose to receptacle (B)
 - Connect the case drain hose to receptacle (C)
 - Connect the electrical harness to receptacle (D)
- Push latch (B) to unlock the platform (A).
- Push the platform (A) towards the cab until it stops and latch engages.

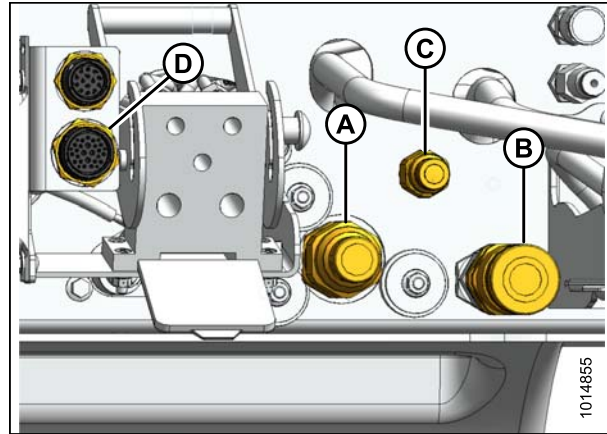

Figure 3.139: Hydraulic and Electrical Connections

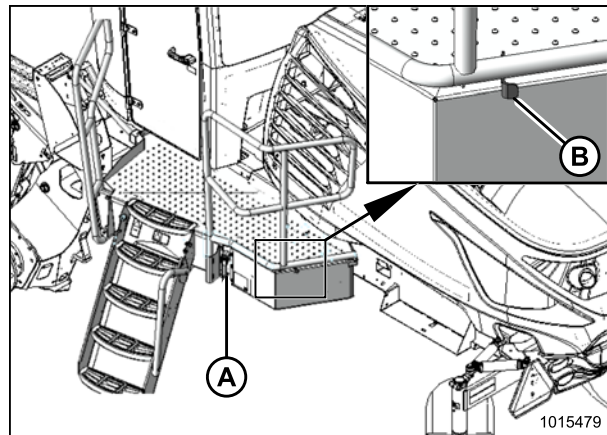

Figure 3.140: Left Cab-Forward Platform

3.14 Installing Other Options

Install options (if supplied with shipment) in accordance with the instructions supplied with each kit.

3.14.1 Installing Tall Crop Divider

To install the tall crop divider kit (MD #B5509), follow these steps:

DANGER

To avoid bodily injury or death from unexpected startup of the machine, always stop the engine and remove the key from the ignition before leaving the operator's seat for any reason.

1. Lower header fully.
2. Stop the engine, and remove the key.
3. Unpack kit.
4. Open cutterbar doors.

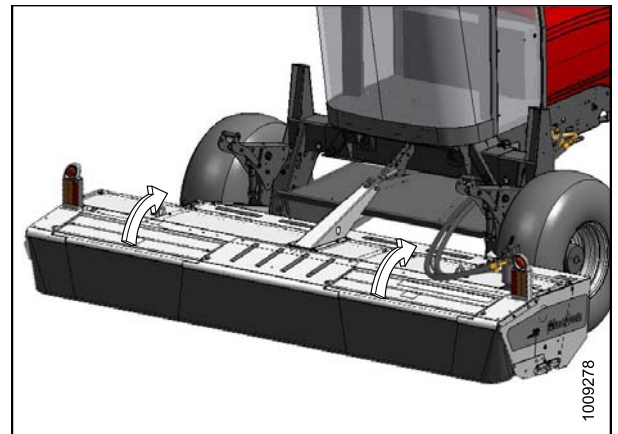

Figure 3.141: Cutterbar Doors

5. Remove the four bolts (A) from the divider (B).

NOTE:

Mounting holes in header should be vacant. Remove fasteners, if necessary.

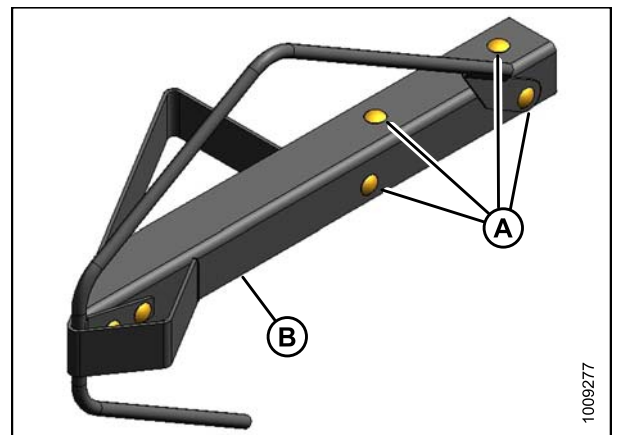

Figure 3.142: Tall Crop Divider Kit (LH Shown, RH Opposite)

ASSEMBLING THE HEADER

6. Position left-hand divider (B) on header left front corner, and install with four bolts (A) and nuts in existing holes. Tighten hardware.
7. Repeat for right-hand side.
8. Lower cutterbar doors.

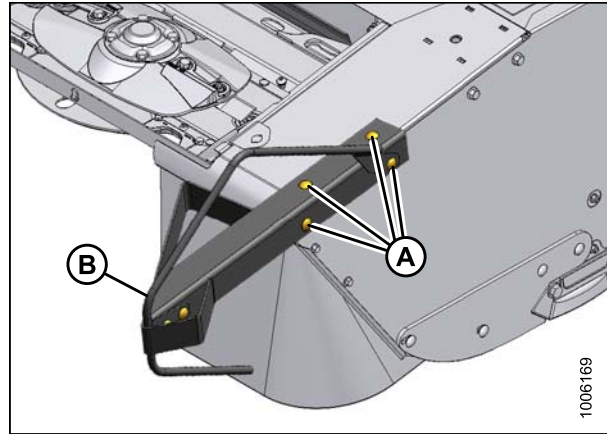

Figure 3.143: Tall Crop Divider Installed

3.14.2 Installing Double Windrow Attachment (DWA)

Refer to instructions supplied with kit.



Figure 3.144: DWA

3.14.3 Installing Skid Shoes (Optional)

DANGER

To avoid bodily injury or death from unexpected startup of the machine, always stop the engine and remove the key from the ignition before leaving the operator's seat for any reason.

1. Lower header to the ground, shut off engine, and remove key from ignition.
2. Unpack kit.

ASSEMBLING THE HEADER

3. Install skid shoes. Refer to instruction (MD #169972) supplied with kit.

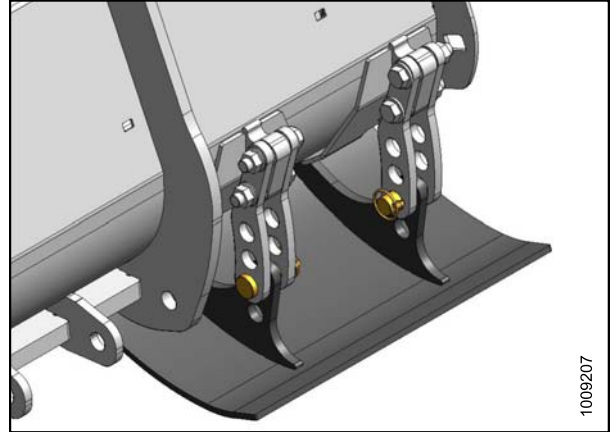

Figure 3.145: Skid Shoe (Right Side Shown – Left Side Similar)

3.14.4 Installing Gauge Rollers (Optional)

DANGER

To avoid bodily injury or death from unexpected startup of the machine, always stop the engine and remove the key from the ignition before leaving the operator's seat for any reason.

1. Unpack gauge roller bundle and install gauge rollers. Refer to instruction (MD #169467) supplied with kit.

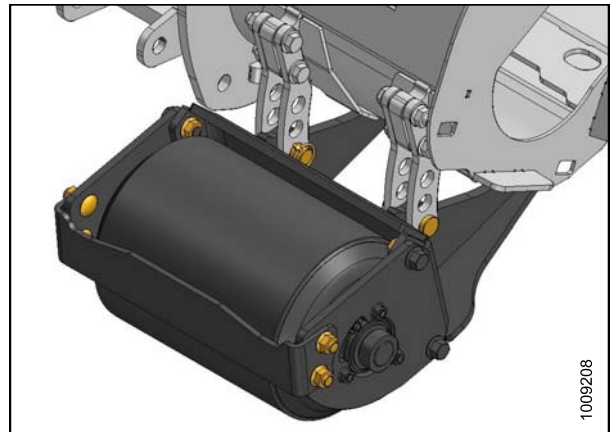

Figure 3.146: Gauge Roller (Right Side Shown – Left Side Similar)

ASSEMBLING THE HEADER

3.14.5 Installing Tall Crop Feed Plates

Two plates (A) are supplied with each header and can be installed if required. They are stored behind the right-hand side driveshield. Installation instructions are included in the operator's manual.

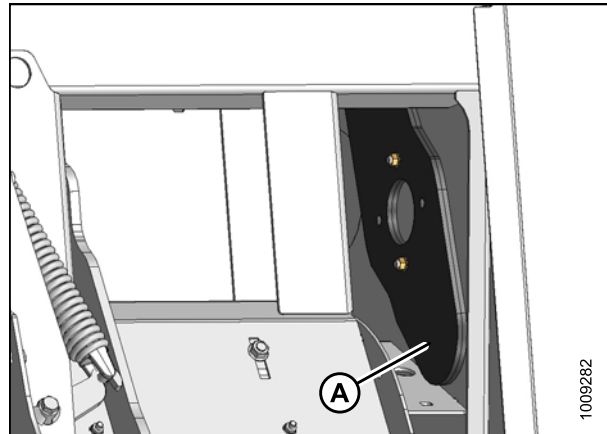

Figure 3.147: Driveshield Removed

3.14.6 Installing Nut Protectors (for Blade Hardware on Discs)

Twelve nut protector caps (A) are supplied as standard equipment with each header. These are shipped bolted to the tall crop feed plates.

The nut protectors can be used in place of the crop accelerators (factory installed on each disc) when cutting in light crop conditions to reduce air turbulence, thereby improving the quality of cut.

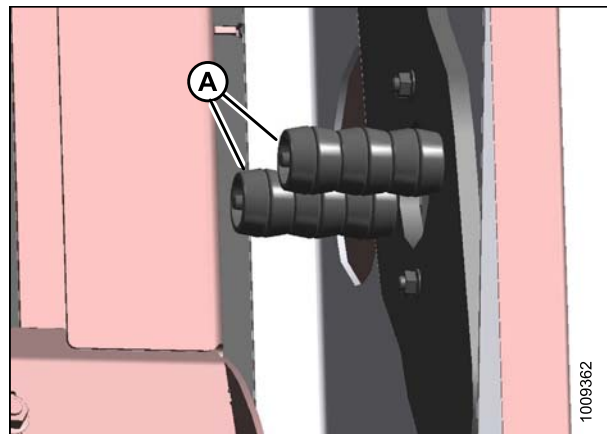

Figure 3.148: Nut Protector Storage Location

3.15 Header Lubrication

The header has been lubricated at the factory. However, you should lubricate the header prior to delivery to offset the effects of weather during outside storage and transport, and to familiarize yourself with the header.

3.15.1 Driveshields

WARNING

Do NOT operate the machine with the driveshields open. High-speed rotating components may throw debris and could result in death or serious injury.

Access to the header drive systems requires opening the driveshield at the left end of the header. The procedures for opening and closing the driveshield vary depending on whether the header was configured for use in North America or outside of North America (export).

Opening the Driveshield: North American Headers

Follow these steps to open the driveshield on North American headers:

1. Release rubber latches (A).
2. Lift shield (B).

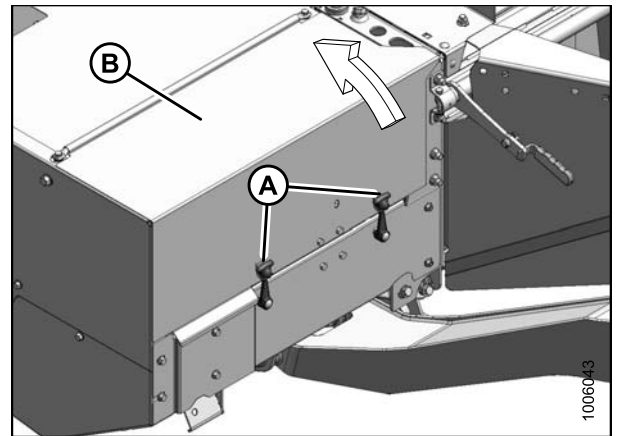

Figure 3.149: Driveshield

ASSEMBLING THE HEADER

Closing the Driveshield: North American Headers

Follow these steps to close the driveshield on North American headers:

1. Lower shield (B) so that pins at lower end of shield engage holes in lower panel.
2. Engage rubber latches (A).

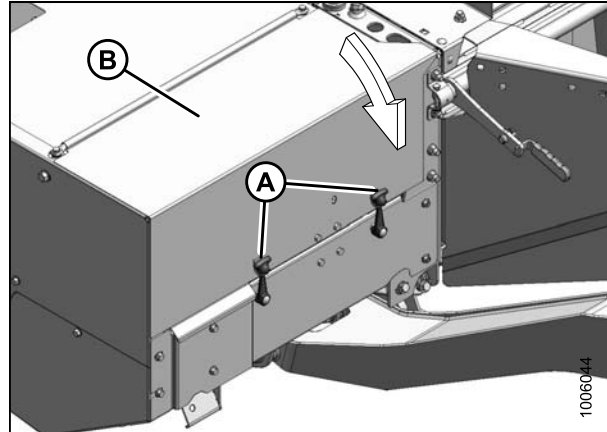

Figure 3.150: Driveshield

Opening the Driveshield: Export Headers

Follow these steps to open the driveshield on export headers:

1. Release rubber latches (A).
2. Insert a screwdriver (or equivalent) through hole in shield (B) and into the notch in latch (C) and disengage latch.
3. Open driveshield (D).

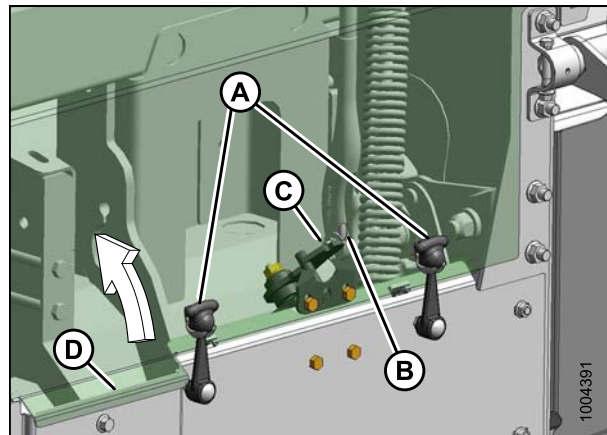

Figure 3.151: Driveshield

ASSEMBLING THE HEADER

Closing the Driveshield: Export Headers

Follow these steps to close the driveshield on export headers:

1. Lower the shield (C) so that pins at lower end of shield engage holes in the lower panel, and latch (B) reengages the driveshield.
2. Engage rubber latches (A).

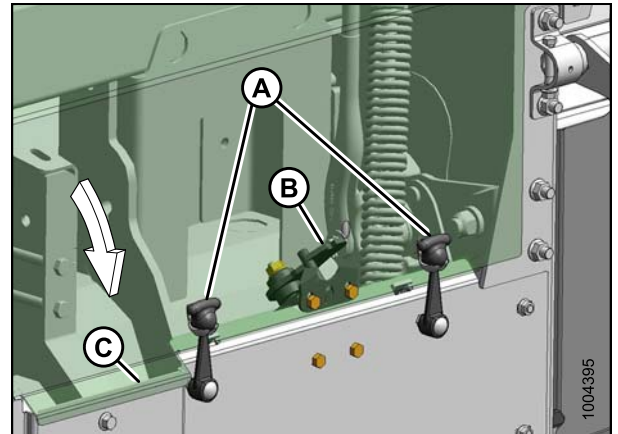

Figure 3.152: Driveshield

3.15.2 Greasing Procedure

⚠ DANGER

To avoid bodily injury or death from unexpected startup of the machine, always stop the engine and remove the key from the ignition before leaving the operator's seat for any reason.

The greasing points are marked on the machine by decals showing a grease gun and grease interval in hours of operation.

1. Wipe grease fitting with a clean cloth to avoid injecting dirt and grit.
2. Inject grease through fitting with grease gun until grease overflows fitting, except where noted.
3. Leave excess grease on fitting to keep out dirt.
4. Replace any loose or broken fittings immediately.
5. If fitting will not take grease, remove and clean thoroughly. Also, clean lubricant passageway. Replace fitting, if necessary.

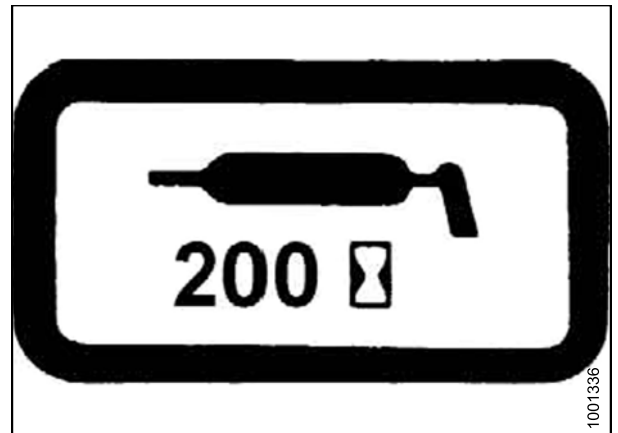

Figure 3.153: Grease Interval Decal

3.15.3 Lubrication Points

To identify the various locations that require lubrication, refer to the following illustrations.

NOTE:

Use high temperature extreme pressure (EP2) performance with 1% max molybdenum disulphide (NLGI grade 2) lithium base except where noted.

ASSEMBLING THE HEADER

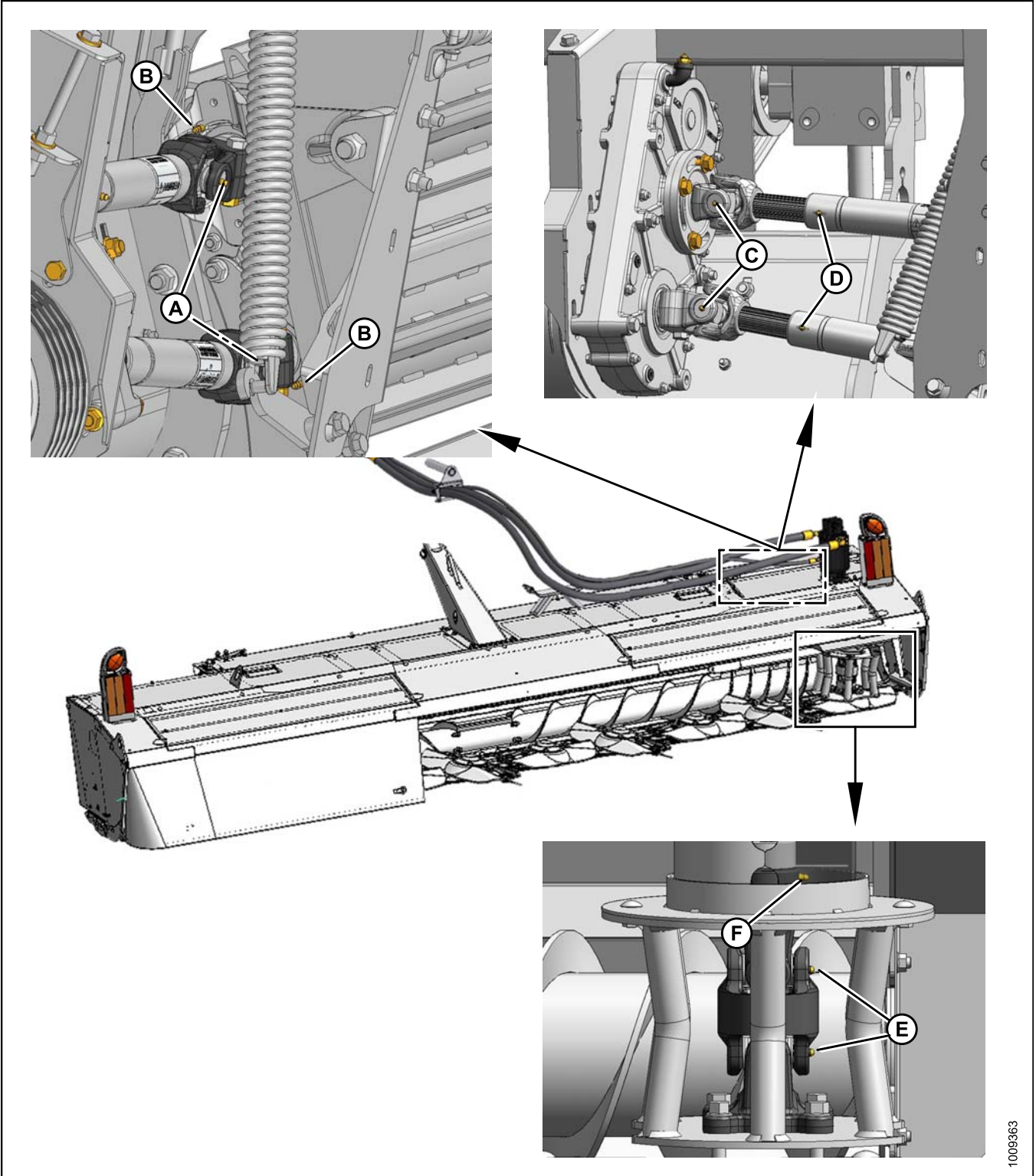

1009363

Figure 3.154: Lubrication Points

A - Driveline Universals (Two Places)
D - Driveline Shaft² (Two Places)

B - Roll Shaft Bearings (Two Places)
E - Driveline Universals² (Two Places)

C - Driveline Universals (Two Places)
F - Driveshaft (One Place)

2. 10% moly grease is recommended for driveline shaft slip joint only.

ASSEMBLING THE HEADER

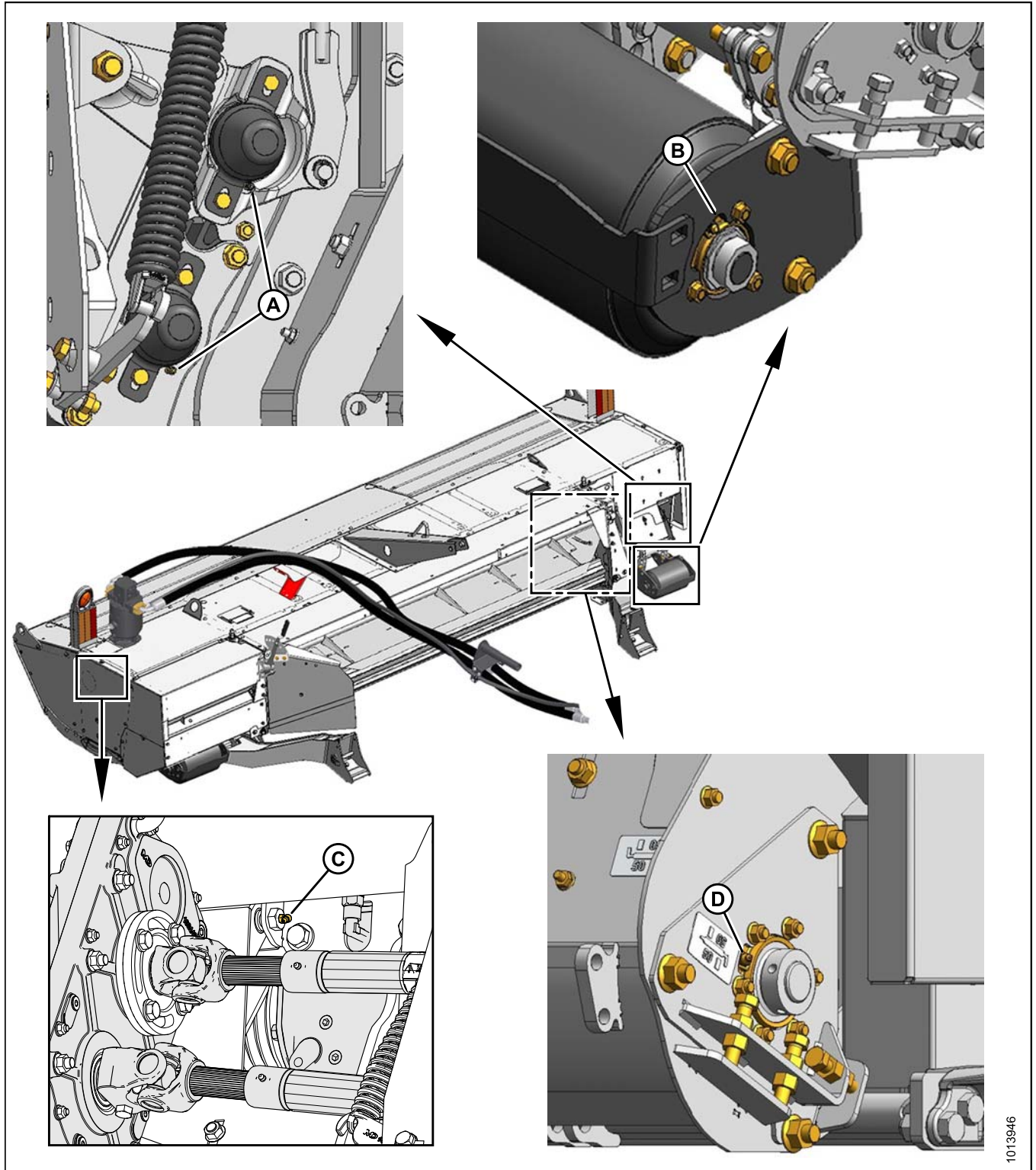

Figure 3.155: Lubrication Points

A - Roll Shaft Bearings (Two Places)
C - Belt Tensioner Pivot (One Place)

B - Optional Gauge Roll Bearings (Two Places) – Both Sides
D - Auger Bearing (One Place)

4 Performing Predelivery Checks

DANGER

To avoid bodily injury or death from unexpected startup of the machine, always stop the engine and remove the key from the ignition before leaving the operator's seat for any reason.

IMPORTANT:

To avoid machine damage, check that no shipping dunnage has fallen down between auger and pans.

1. Perform final checks and adjustments as listed on the [Predelivery Checklist, page 111](#) (yellow sheet attached to back of this instruction) to ensure the machine is field-ready. Refer to the referenced pages as indicated on the checklist for detailed instructions.
2. The completed checklist should be retained either by the Operator or the Dealer.

4.1 Checking Drive Belts

Drive belt tensions have been properly set at the factory and should not require any further adjustment. Check as follows:

1. Open driveshield. For instructions, refer to [3.15.1 Driveshields, page 73](#).

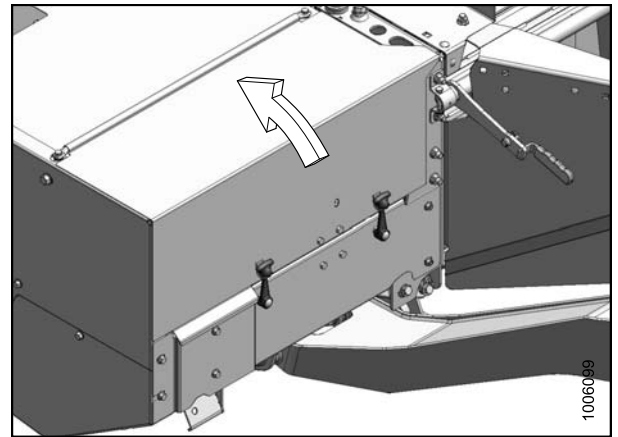

Figure 4.1: Driveshield

PERFORMING PREDELIVERY CHECKS

2. Check that adjuster nut (A) is tight and that conditioner drive belt (B) is tensioned.
3. Check that end of slots (C) are aligned with plate (D).

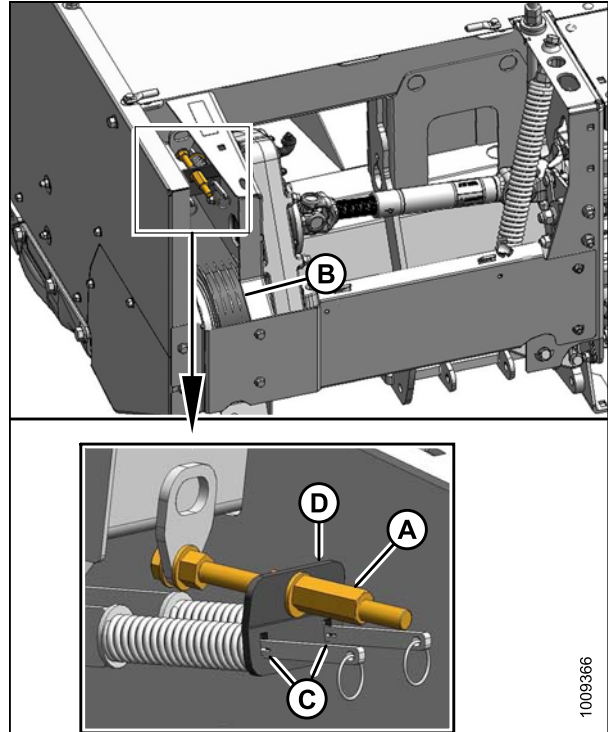

Figure 4.2: Conditioner Drive Belt Tension

4. Raise header fully, turn off engine, and remove key. Engage header safety props.
5. To check auger belt tension, spring length (A) should measure 262 mm (10.3 in.).
6. Lower header and close driveshield.

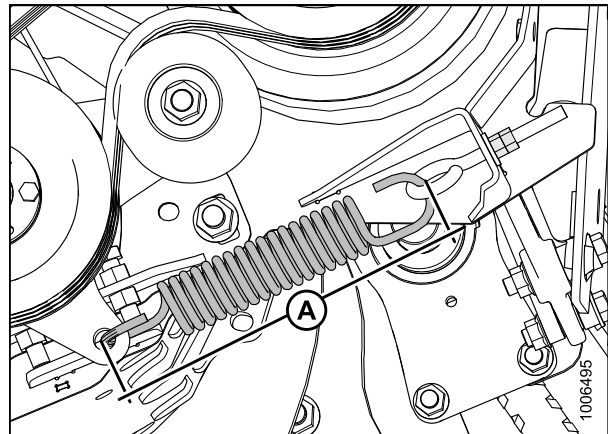

Figure 4.3: Auger Belt Tension

4.2 Checking Header Float

CAUTION

Check to be sure all bystanders have cleared the area.

1. Start engine and lower header to ground, and ensure header lift cylinders are fully retracted.
2. Adjust the header angle/tilt to mid-range position with the switches (A, B) on the windrower ground speed lever (GSL).
3. Set the float fine adjustment to mid-range with the windrower float adjustment system in the cab. Refer to the windrower operator's manual.

DANGER

To avoid bodily injury or death from unexpected startup of the machine, always stop the engine and remove the key from the ignition before leaving the operator's seat for any reason.

4. Stop engine, and remove key from ignition.
5. Check float by grasping the front corner of header and lifting. The force to lift should be 426–471 N (95–105 lbf), and should be approximately the same at both ends.
6. Perform the following steps to adjust the float (if necessary):
 - a. Start engine, and raise header fully.
 - b. Shut down engine, and remove the key.
 - c. Turn drawbolt (A):
 - **Clockwise to increase float** (make header lighter)
 - **Counterclockwise to decrease float** (make header heavier)
 - d. Recheck the float.

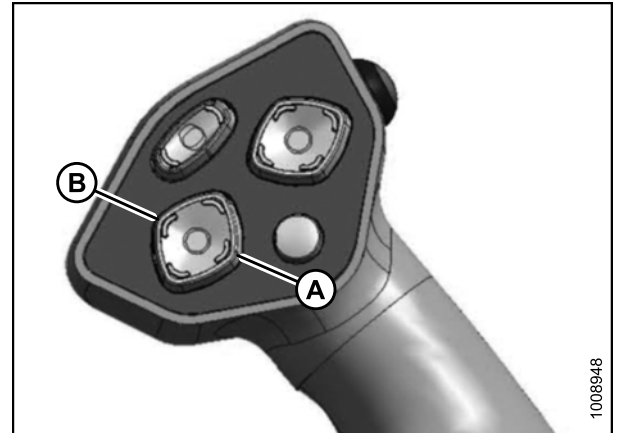

Figure 4.4: Header Tilt Switches

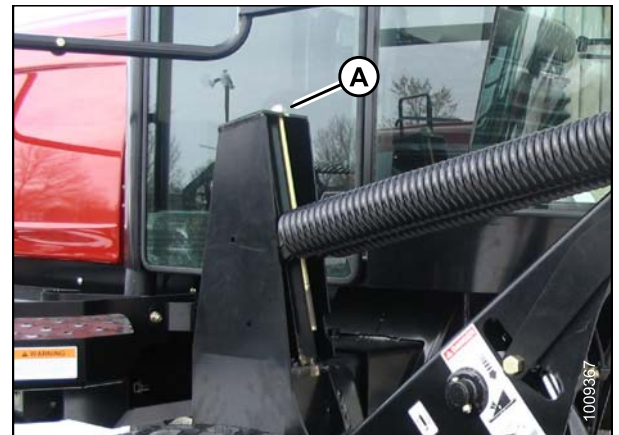

Figure 4.5: Float Adjustment

4.3 Checking Header Level

To check and adjust header level, follow these steps:

⚠ DANGER

To avoid bodily injury or death from unexpected startup of the machine, always stop the engine and remove the key from the ignition before leaving the operator's seat for any reason.

1. Park windrower on level ground, and raise header off ground approximately 150 mm (6 in.).
2. Shut off engine, and check that clearances (A) between header and ground at each end of the header are approximately the same.
3. If header does **NOT** need levelling, skip remaining steps. If header **DOES** need levelling, proceed as follows:

IMPORTANT:

The header float springs are **NOT** used to level the header.

4. Observe which side of header is the high side and which is the low side.

⚠ CAUTION

Check to be sure all bystanders have cleared the area.

5. Start the engine, and raise header fully.
6. Stop engine, and remove key.
7. Move float engagement pin from hole (A) to hole (B) at front of linkage.

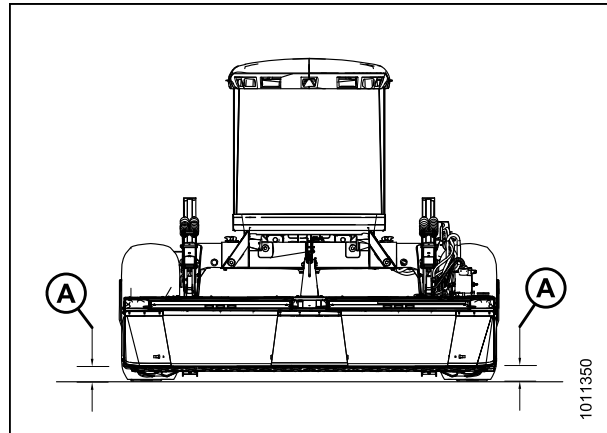

Figure 4.6: Level Header

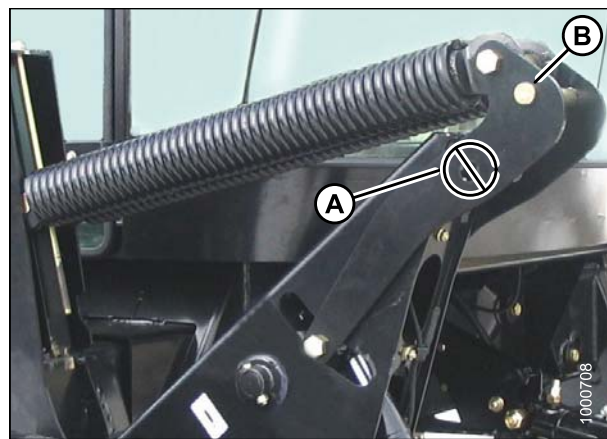

Figure 4.7: Header Lift Linkage

PERFORMING PREDELIVERY CHECKS

- Place wooden blocks under header cutterbar and header lift linkage.
- Disengage header safety props.



Figure 4.8: Wooden Block

CAUTION

Check to be sure all bystanders have cleared the area.

- Start engine, and lower header onto blocks so that header lift linkage (A) lifts at windrower leg and off of shims.
- Shut down engine, and remove key.

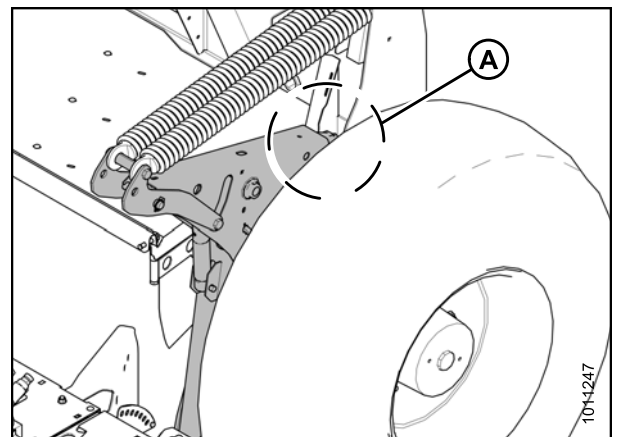

Figure 4.9: Header Lift Linkage

- On the high side linkage (A), remove nut, washer, and bolt (C) that attach shims (B) to link.
- Remove one or both shims (B), and reinstall the hardware (C).
- Raise header approximately 150 mm (6 in.) off ground, and check level of header.
- If additional levelling is required, install the removed shim on the opposite linkage (low side).

NOTE:

Float does **NOT** require adjustment after levelling header.

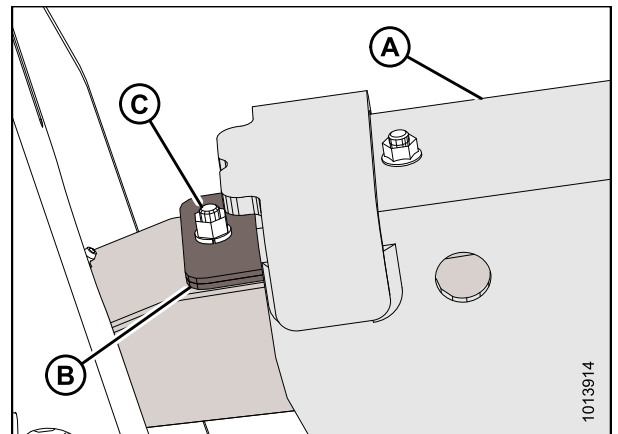

Figure 4.10: Header Lift Linkage: Top View

4.4 Checking Conditioner Rolls

4.4.1 Checking Conditioner Roll Gap

1. Check the size of the gap between the conditioner rolls. The amount of thread protruding from jam nut should be 30 mm (1-3/16 in.). This equates to 25 mm (1 in.) of roll gap.

NOTE:

If roll gap is not set correctly, refer to the header operator's manual for padjustment procedure.

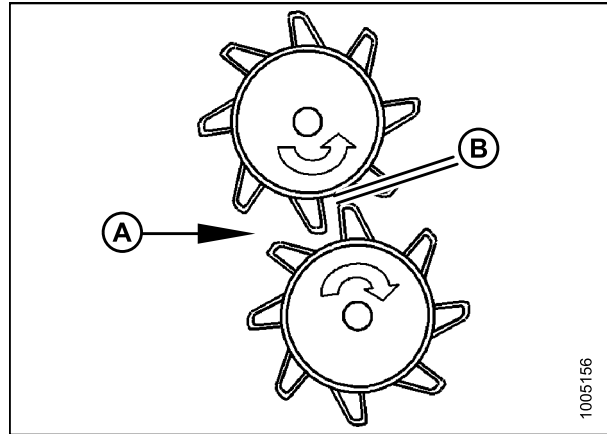

Figure 4.11: Roll Gap

A - Crop

B - Roll Gap

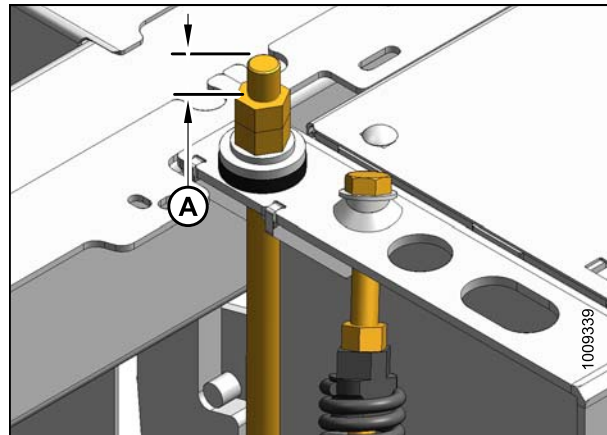

Figure 4.12: Measuring Threads

A - 30 mm (1-3/16 in.)

4.4.2 Checking Conditioner Roll Timing

⚠ DANGER

To avoid bodily injury or death from unexpected startup of the machine, always stop the engine and remove the key from the ignition before leaving the operator's seat for any reason.

1. Header should be on the ground and tractor should be shut down. Ensure key is removed from ignition.
2. Open driveshield. For instructions, refer to [3.15.1 Driveshields, page 73](#).

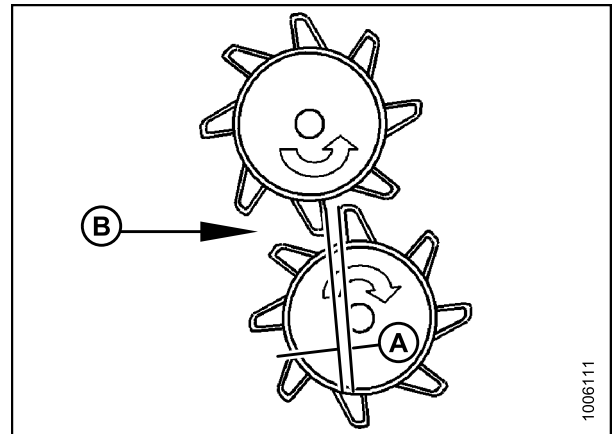

Figure 4.13: Roll Timing

A - Timing Gap

B - Crop

3. Remove bolt (A) and nut, and remove gauge (B) from flanged frame member.

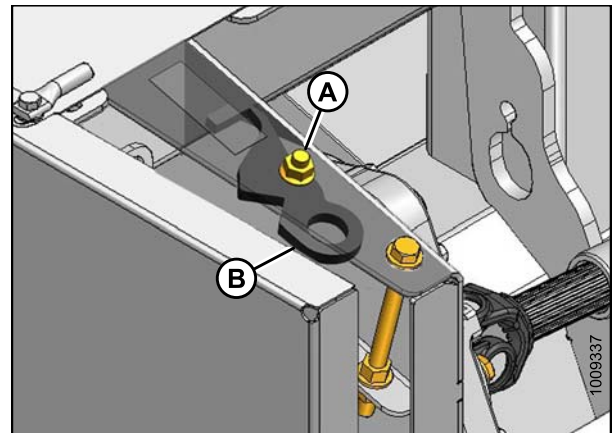

Figure 4.14: Roll Timing Gauge in Storage Position

4. From the rear of the header, position gauge (B) at center of rolls as shown, and manually turn rolls to limits of gauge. Rolls will engage the gauge if timing is correct.
5. Manually turn rolls to release gauge.



Figure 4.15: Roll Timing Gauge in Use

A - Start Position

B - Gauge Position

PERFORMING PREDELIVERY CHECKS

WARNING

Remove gauge from rolls and return it to storage location before starting machine.

6. Replace gauge (B) in header with bolt (A) and nut.

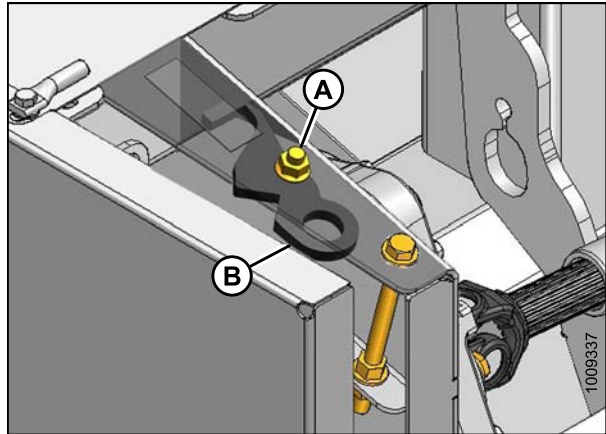

Figure 4.16: Roll Timing Gauge in Storage Position

7. Check timing flange bolts (A) are tight.

NOTE:

If rolls are out of time, refer to the header operator's manual for procedure to adjust.

8. Close driveshield.

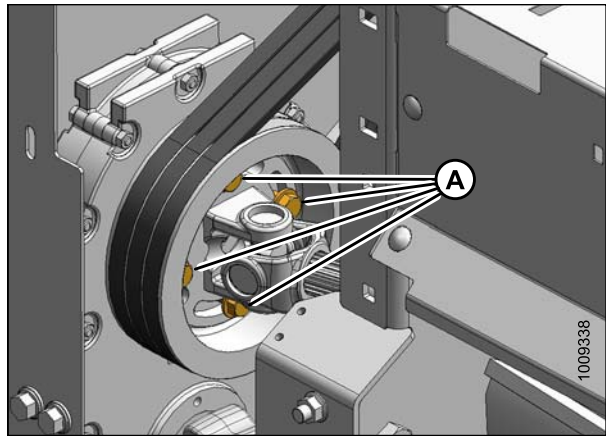

Figure 4.17: Conditioner Gearbox

4.5 Checking Gauge Rollers or Skid Shoes

DANGER

To avoid bodily injury or death from unexpected startup of the windrower, always stop the engine and remove the key from the ignition before leaving the operator's seat for any reason.

1. Raise header, and engage header safety props.
2. Both gauge rollers or skid shoes should be set at the same position.

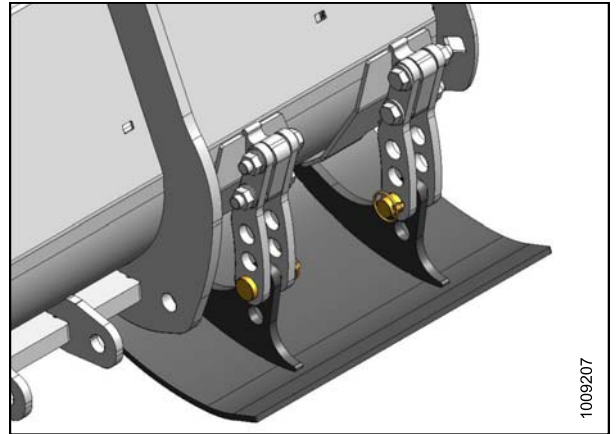

Figure 4.18: Skid Shoe

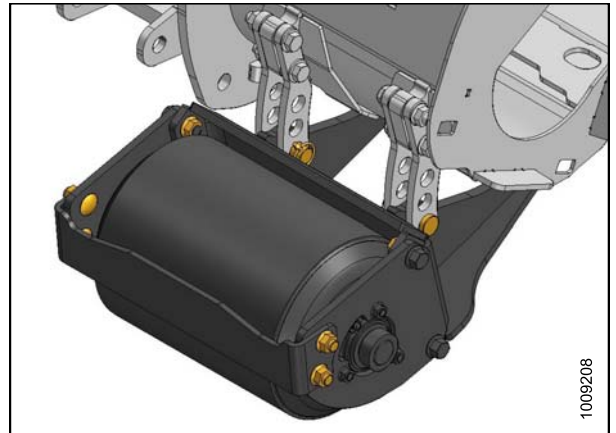

Figure 4.19: Gauge Roller

4.6 Preparing the Bevel Gearbox

To prepare the bevel gearbox and check the oil level, follow these steps:

1. Adjust header height and angle so that top of header is horizontal.
2. Open the driveshield.

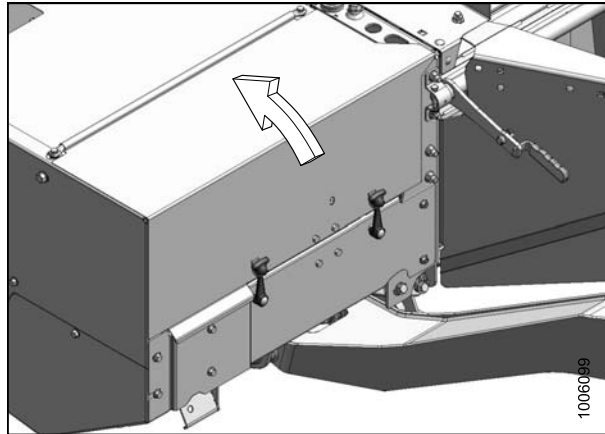

Figure 4.20: Driveshield

3. Cut cable ties and remove bags (A and B) from the breather pipe elbows.

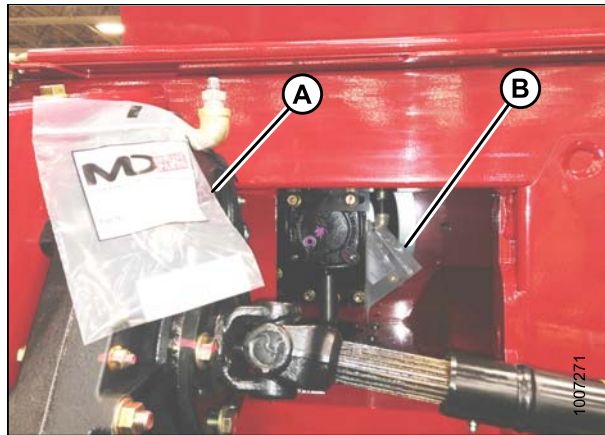

Figure 4.21: Bevel Gearbox

4. Remove plug from breather pipe (A) and replace with breather cap in bag. Discard bag and plug.
5. Remove check plug (B) to check oil level. Oil should slightly run out when removed.

NOTE:

If the oil level is low, top up with a 75W90 synthetic gear lubricant with high thermal and oxidation stability conforming to API GL-5 minimum (SAE J2360 preferred) specifications such as Traxon E Synthetic 75W90 gear oil.

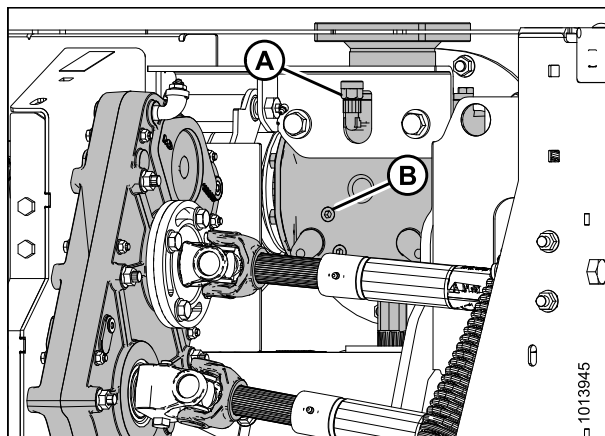

Figure 4.22: Bevel Gearbox

4.7 Preparing the Conditioner Gearbox

To prepare the conditioner gearbox and check the oil level, follow these steps:

1. Adjust the header height and angle until the top of the conditioner gearbox (A) is level with the ground (B).

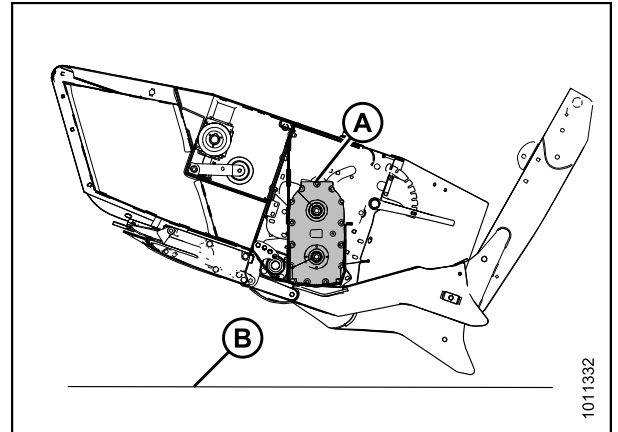

Figure 4.23: Conditioner Gearbox

2. Open the driveshield.

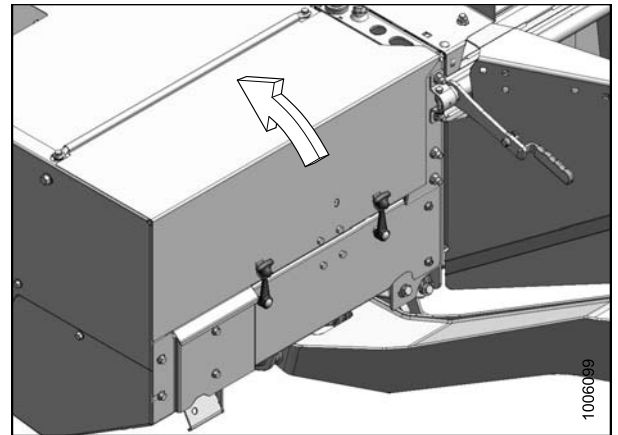

Figure 4.24: Driveshield

3. Cut cable ties and remove bags (A and B) from the breather pipe elbows.

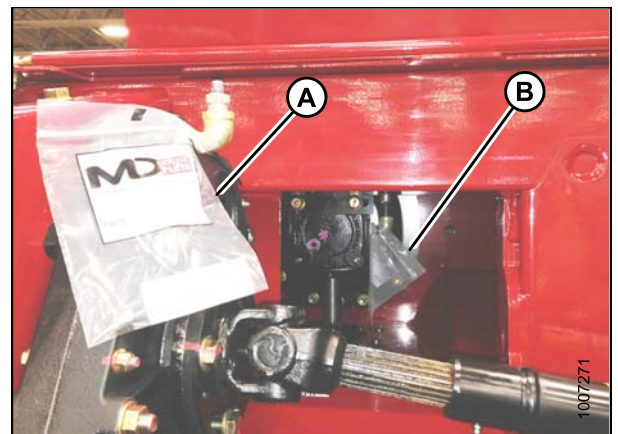

Figure 4.25: Bevel and Conditioner Gearbox

PERFORMING PREDELIVERY CHECKS

4. Remove the plug from breather pipe (A) and replace it with the breather cap in bag. Discard bag and plug.
5. Remove check plug (B) to check oil level. Oil should slightly run out when removed.

NOTE:

If the oil does not run out, top up with a 75W90 synthetic gear lubricant with high thermal and oxidation stability conforming to API GL-5 minimum (SAE J2360 preferred) specifications such as Traxon E Synthetic 75W90 gear oil.

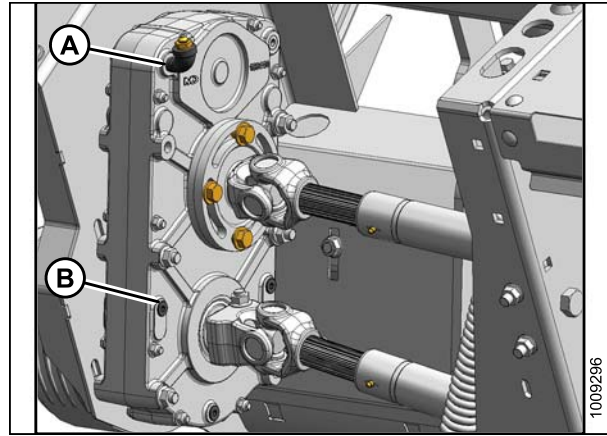

Figure 4.26: Conditioner Gearbox

4.8 Checking Lights

The hazard lights are mounted on both ends of the header, and activated by a switch in the windrower cab.

1. Check for operation during run-up.
2. Check light mountings for security, and check lights for damage.

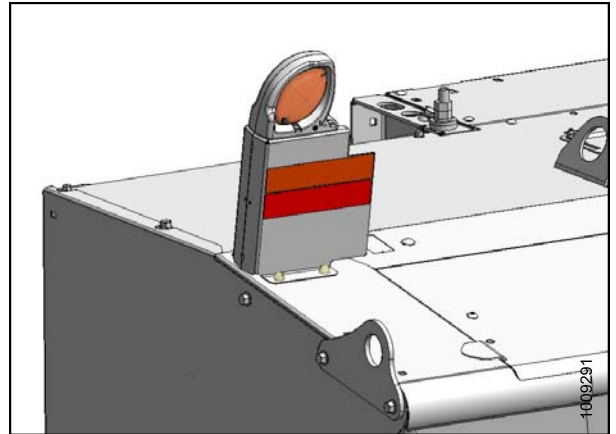

Figure 4.27: Hazard Light

4.9 Checking Manuals

The following manuals should be stored in the manual storage case (A) on the right-hand side of the header:

- R85 16-Foot Rotary Disc Pull-Type Mower Conditioner and Self-Propelled Windrower Header Parts Catalog
- R85 Rotary Disc 16-Footer Header for Self-Propelled Windrower Operator's Manual

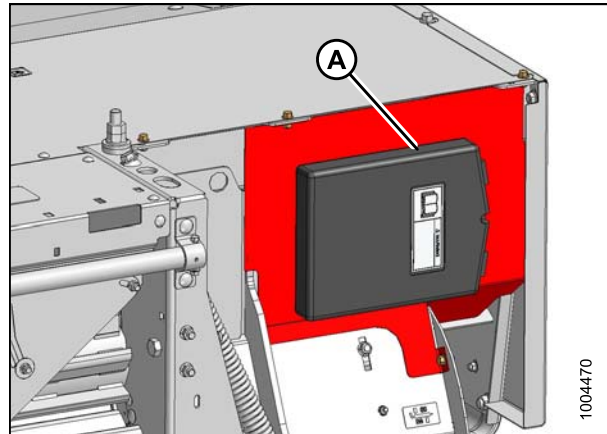

Figure 4.28: Manual Storage Case

4.10 Running up the Header

DANGER

- Keep everyone several hundred feet away from your operation. Ensure bystanders are never in line with the front or rear of the machine. Stones or other foreign objects can be ejected from either end with force.
- Take extreme care to avoid injury from thrown objects. Do NOT, under any circumstances, operate the header when other people are in the vicinity. Stones and other objects can be thrown great distances by the rotating cutting blades.
- Check cutterbar area carefully for loose parts and hardware on the cutterbar. These objects can be ejected with considerable force when the machine is started, and may result in serious injury or machine damage.
- The cutterbar curtains are very important to reduce the potential for thrown objects. Always keep these curtains down when operating the header. Replace the curtains if they should become worn or damaged.

DANGER

Before investigating an unusual sound or attempting to correct a problem, shut off engine, engage parking brake, and remove key.

CAUTION

Never start or move the machine until you are sure all bystanders have cleared the area.

Refer to your windrower operator's manual for windrower operating instructions.

NOTE:

Higher engine rpm may be required to engage the header. Do **NOT** exceed 1800 rpm.

1. Start the windrower.
2. Set header 152–305 mm (6–12 in.) above the ground and adjust center-link to mid-position.
3. Run the machine slowly for 5 minutes, watching, and listening FROM **THE OPERATOR'S SEAT** for binding or interfering parts.
4. Run the machine at operating speed for 15 minutes. Listen for any unusual sounds or abnormal vibration.
5. Perform the run-up check as listed on the [Predelivery Checklist, page 111](#) (yellow sheet attached to this instruction) to ensure the machine is field-ready.
6. Retain the Checklist and if desired, retain this instruction for future reference.

5 Reference

5.1 Torque Specifications

The following tables provide the correct torque values for various bolts, cap screws, and hydraulic fittings.

- Tighten all bolts to torque values specified in charts (unless otherwise noted throughout this manual).
- Replace hardware with same strength and grade of bolt.
- Use torque value tables as a guide and periodically check tightness of bolts.
- Understand torque categories for bolts and cap screws by using their identifying head markings.

5.1.1 SAE Bolt Torque Specifications

Torque values shown in the following tables are valid for non-greased, or non-oiled threads and heads; therefore, do **NOT** grease or oil bolts or cap screws unless otherwise specified in this manual.

Table 5.1 SAE Grade 5 Bolt and Grade 5 Free Spinning Nut

Nominal Size (A)	Torque (N·m)		Torque (ft·lbf) (*in·lbf)	
	Min.	Max.	Min.	Max.
1/4-20	11.9	13.2	*106	*117
5/16-18	24.6	27.1	*218	*241
3/8-16	44	48	32	36
7/16-14	70	77	52	57
1/2-13	106	118	79	87
9/16-12	153	170	114	126
5/8-11	212	234	157	173
3/4-10	380	420	281	311
7/8-9	606	669	449	496
1-8	825	912	611	676

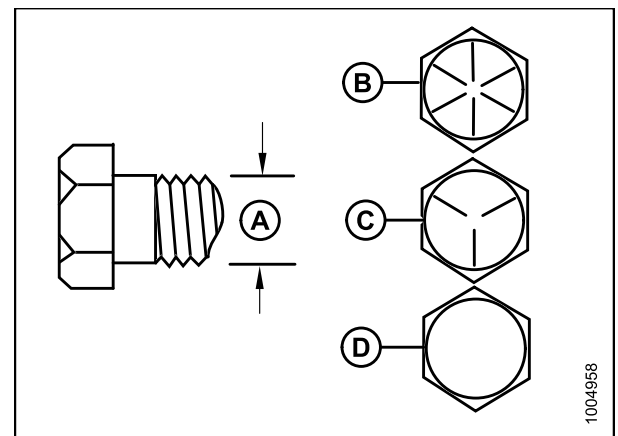

Figure 5.1: Bolt Grades

A - Nominal Size
C - SAE-5

B - SAE-8
D - SAE-2

1004958

REFERENCE

Table 5.2 SAE Grade 5 Bolt and Grade F Distorted Thread Nut

Nominal Size (A)	Torque (N·m)		Torque (ft·lbf) (*in·lbf)	
	Min.	Max.	Min.	Max.
1/4-20	8.1	9	*72	*80
5/16-18	16.7	18.5	*149	*164
3/8-16	30	33	22	24
7/16-14	48	53	35	39
1/2-13	73	80	54	59
9/16-12	105	116	77	86
5/8-11	144	160	107	118
3/4-10	259	286	192	212
7/8-9	413	456	306	338
1-8	619	684	459	507

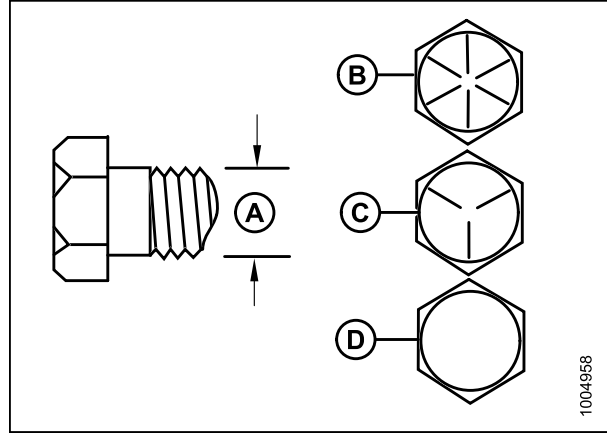

Figure 5.2: Bolt Grades

A - Nominal Size
 B - SAE-8
 C - SAE-5
 D - SAE-2

Table 5.3 SAE Grade 8 Bolt and Grade G Distorted Thread Nut

Nominal Size (A)	Torque (N·m)		Torque (ft·lbf) (*in·lbf)	
	Min.	Max.	Min.	Max.
1/4-20	16.8	18.6	*150	*165
5/16-18	24	26	18	19
3/8-16	42	46	31	34
7/16-14	67	74	50	55
1/2-13	102	113	76	84
9/16-12	148	163	109	121
5/8-11	204	225	151	167
3/4-10	362	400	268	296
7/8-9	583	644	432	477
1-8	874	966	647	716

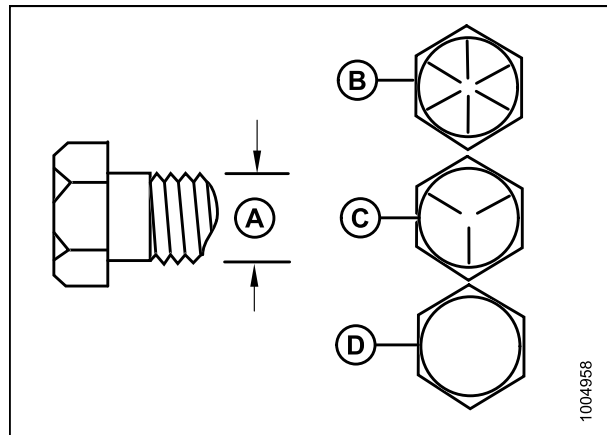

Figure 5.3: Bolt Grades

A - Nominal Size
 B - SAE-8
 C - SAE-5
 D - SAE-2

REFERENCE

Table 5.4 SAE Grade 8 Bolt and Grade 8 Free Spinning Nut

Nominal Size (A)	Torque (N-m)		Torque (ft-lbf) (*in-lbf)	
	Min.	Max.	Min.	Max.
1/4-20	16.8	18.6	*150	*165
5/16-18	35	38	26	28
3/8-16	61	68	46	50
7/16-14	98	109	73	81
1/2-13	150	166	111	123
9/16-12	217	239	160	177
5/8-11	299	330	221	345
3/4-10	531	587	393	435
7/8-9	855	945	633	700
1-8	1165	1288	863	954

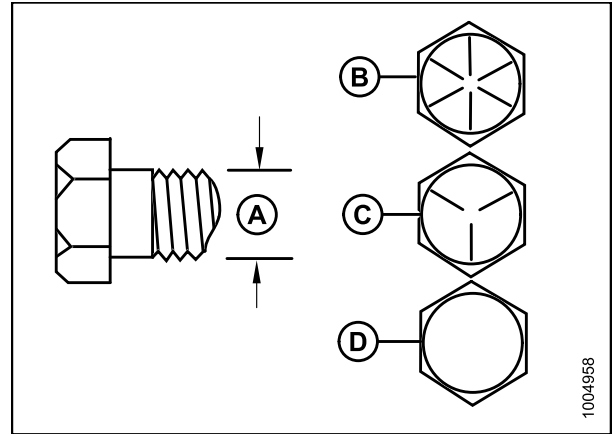

Figure 5.4: Bolt Grades

A - Nominal Size
C - SAE-5

B - SAE-8
D - SAE-2

5.1.2 Metric Bolt Specifications

Table 5.5 Metric Class 8.8 Bolts and Class 9 Free Spinning Nut

Nominal Size (A)	Torque (N-m)		Torque (ft-lbf) (*in-lbf)	
	Min.	Max.	Min.	Max.
3-0.5	1.4	1.6	*13	*14
3.5-0.6	2.2	2.5	*20	*22
4-0.7	3.3	3.7	*29	*32
5-0.8	6.7	7.4	*59	*66
6-1.0	11.4	12.6	*101	*112
8-1.25	28	30	20	23
10-1.5	55	60	40	45
12-1.75	95	105	70	78
14-2.0	152	168	113	124
16-2.0	236	261	175	193
20-2.5	460	509	341	377
24-3.0	796	879	589	651

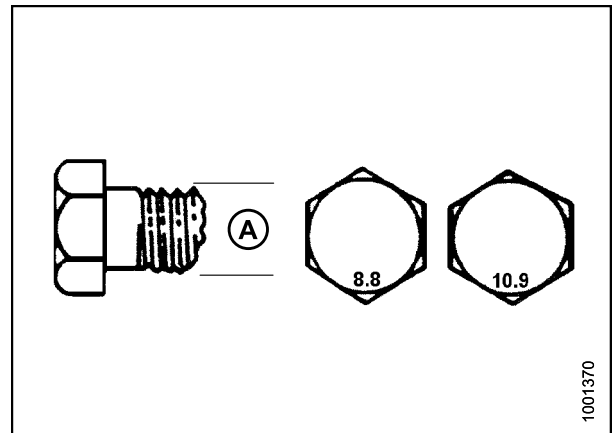

Figure 5.5: Bolt Grades

REFERENCE

Table 5.6 Metric Class 8.8 Bolts and Class 9 Distorted Thread Nut

Nominal Size (A)	Torque (N·m)		Torque (ft·lbf) (*in·lbf)	
	Min.	Max.	Min.	Max.
3-0.5	1	1.1	*9	*10
3.5-0.6	1.5	1.7	*14	*15
4-0.7	2.3	2.5	*20	*22
5-0.8	4.5	5	*40	*45
6-1.0	7.7	8.6	*69	*76
8-1.25	18.8	20.8	*167	*185
10-1.5	37	41	28	30
12-1.75	65	72	48	53
14-2.0	104	115	77	85
16-2.0	161	178	119	132
20-2.5	314	347	233	257
24-3.0	543	600	402	444

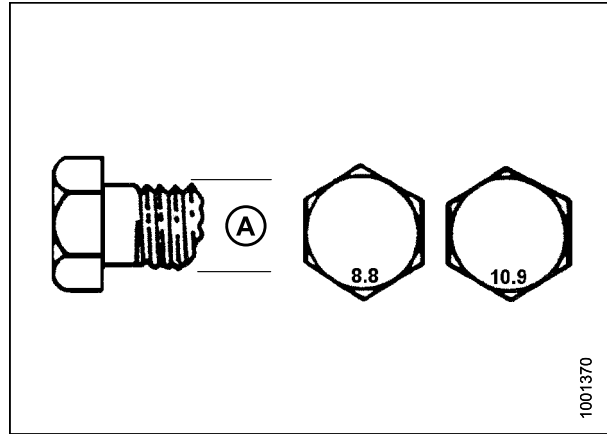

Figure 5.6: Bolt Grades

Table 5.7 Metric Class 10.9 Bolts and Class 10 Free Spinning Nut

Nominal Size (A)	Torque (N·m)		Torque (ft·lbf) (*in·lbf)	
	Min.	Max.	Min.	Max.
3-0.5	1.8	2	*18	*19
3.5-0.6	2.8	3.1	*27	*30
4-0.7	4.2	4.6	*41	*45
5-0.8	8.4	9.3	*82	*91
6-1.0	14.3	15.8	*140	*154
8-1.25	38	42	28	31
10-1.5	75	83	56	62
12-1.75	132	145	97	108
14-2.0	210	232	156	172
16-2.0	326	360	242	267
20-2.5	637	704	472	521
24-3.0	1101	1217	815	901

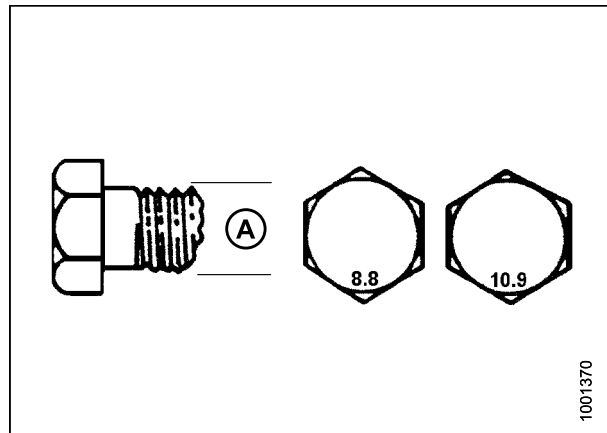

Figure 5.7: Bolt Grades

REFERENCE

Table 5.8 Metric Class 10.9 Bolts and Class 10 Distorted Thread Nut

Nominal Size (A)	Torque (N·m)		Torque (ft·lbf) (*in·lbf)	
	Min.	Max.	Min.	Max.
3-0.5	1.3	1.5	*12	*13
3.5-0.6	2.1	2.3	*19	*21
4-0.7	3.1	3.4	*28	*31
5-0.8	6.3	7	*56	*62
6-1.0	10.7	11.8	*95	*105
8-1.25	26	29	19	21
10-1.5	51	57	38	42
12-1.75	90	99	66	73
14-2.0	143	158	106	117
16-2.0	222	246	165	182
20-2.5	434	480	322	356
24-3.0	750	829	556	614

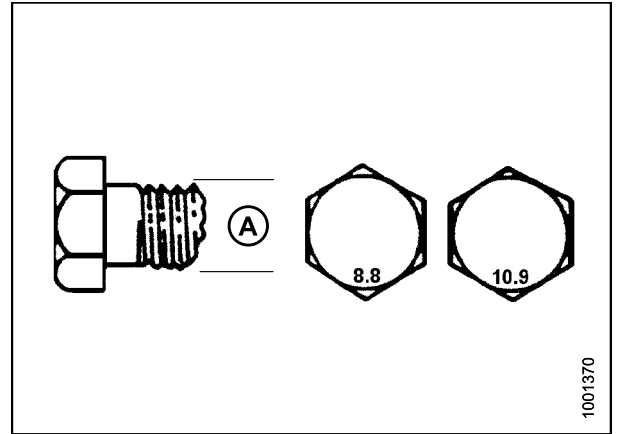

Figure 5.8: Bolt Grades

5.1.3 Metric Bolt Specifications Bolting into Cast Aluminum

Table 5.9 Metric Bolt Bolting into Cast Aluminum

Nominal Size (A)	Bolt Torque			
	8.8 (Cast Aluminum)		10.9 (Cast Aluminum)	
	N·m	ft·lbf	N·m	ft·lbf
M3	–	–	–	1
M4	–	–	4	2.6
M5	–	–	8	5.5
M6	9	6	12	9
M8	20	14	28	20
M10	40	28	55	40
M12	70	52	100	73
M14	–	–	–	–
M16	–	–	–	–

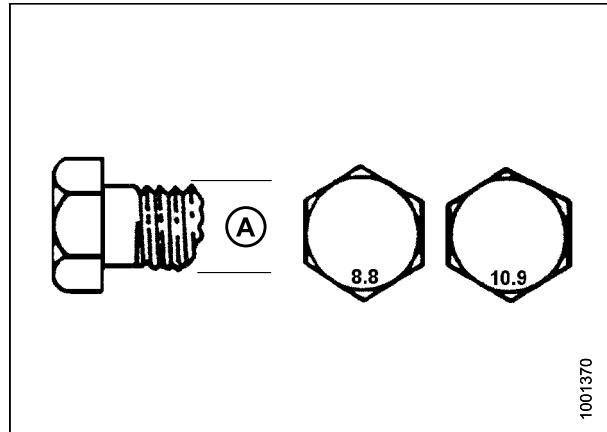

Figure 5.9: Bolt Grades

5.1.4 Flare-Type Hydraulic Fittings

1. Check flare (A) and flare seat (B) for defects that might cause leakage.
2. Align tube (C) with fitting (D) and thread nut (E) onto fitting without lubrication until contact has been made between flared surfaces.
3. Torque fitting nut (E) to specified number of flats from finger tight (FFFT) or to a given torque value in [Table 5.10 Flare-Type Hydraulic Tube Fittings, page 101](#).
4. Use two wrenches to prevent fitting (D) from rotating. Place one wrench on fitting body (D), and tighten nut (E) with other wrench to torque shown.
5. Assess final condition of connection.

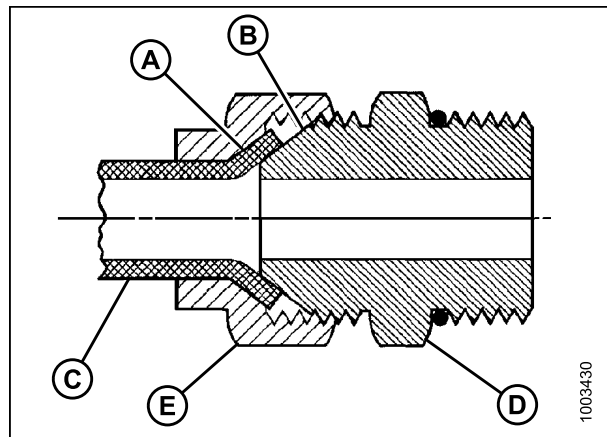

Figure 5.10: Hydraulic Fitting

REFERENCE

Table 5.10 Flare-Type Hydraulic Tube Fittings

SAE Dash Size	Thread Size (in.)	Torque Value ³		Flats from Finger Tight (FFFT)	
		N-m	ft-lbf	Tube	Swivel Nut or Hose
-2	5/16-24	4-5	3-4	—	—
-3	3/8-24	7-8	5-6	—	—
-4	7/16-20	18-19	13-14	2-1/2	2
-5	1/2-20	19-21	14-15	2	2
-6	9/16-18	30-33	22-24	2	1-1/2
-8	3/4-16	57-63	42-46	2	1-1/2
-10	7/8-14	81-89	60-66	1-1/2	1-1/2
-12	1-1/16-12	113-124	83-91	1-1/2	1-1/4
-14	1-3/16-12	136-149	100-110	1-1/2	1-1/4
-16	1-5/16-12	160-176	118-130	1-1/2	1
-20	1-5/8-12	228-250	168-184	1	1
-24	1-7/8-12	264-291	195-215	1	1
-32	2-1/2-12	359-395	265-291	1	1
-40	3-12	—	—	1	1

3. Torque values shown are based on lubricated connections as in reassembly.

REFERENCE

5.1.5 O-Ring Boss (ORB) Hydraulic Fittings (Adjustable)

1. Inspect O-ring (A) and seat (B) for dirt or obvious defects.
2. Back off lock nut (C) as far as possible. Ensure that washer (D) is loose and is pushed toward lock nut (C) as far as possible.
3. Check that O-ring (A) is **NOT** on threads and adjust if necessary.
4. Apply hydraulic system oil to O-ring (A).

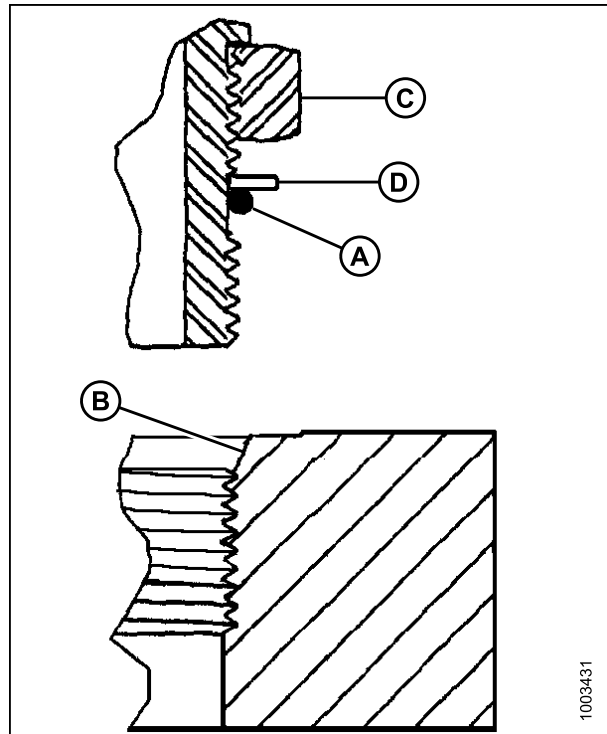

Figure 5.11: Hydraulic Fitting

5. Install fitting (B) into port until back up washer (D) and O-ring (A) contact part face (E).
6. Position angle fittings by unscrewing no more than one turn.
7. Turn lock nut (C) down to washer (D) and tighten to torque shown. Use two wrenches, one on fitting (B) and other on lock nut (C).
8. Check final condition of fitting.

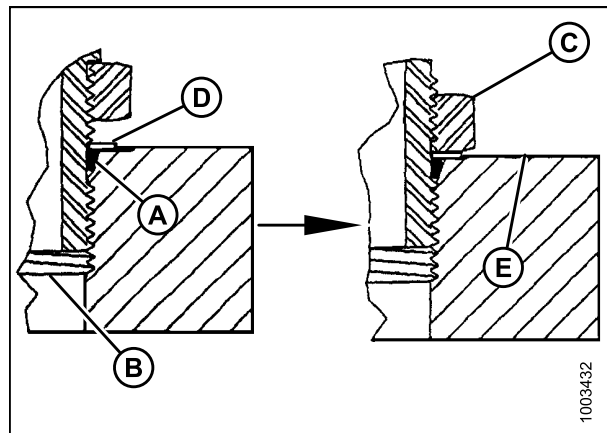

Figure 5.12: Hydraulic Fitting

REFERENCE

Table 5.11 O-Ring Boss (ORB) Hydraulic Fittings (Adjustable)

SAE Dash Size	Thread Size (in.)	Torque Value ⁴	
		N·m	ft·lbf (*in·lbf)
-2	5/16–24	6–7	*53–62
-3	3/8–24	12–13	*106–115
-4	7/16–20	19–21	14–15
-5	1/2–20	21–33	15–24
-6	9/16–18	26–29	19–21
-8	3/4–16	46–50	34–37
-10	7/8–14	75–82	55–60
-12	1-1/16–12	120–132	88–97
-14	1-3/8–12	153–168	113–124
-16	1-5/16–12	176–193	130–142
-20	1-5/8–12	221–243	163–179
-24	1-7/8–12	270–298	199–220
-32	2-1/2–12	332–365	245–269

4. Torque values shown are based on lubricated connections as in reassembly.

REFERENCE

5.1.6 O-Ring Boss (ORB) Hydraulic Fittings (Non-Adjustable)

1. Inspect O-ring (A) and seat (B) for dirt or obvious defects.
2. Check that O-ring (A) is **NOT** on threads and adjust if necessary.
3. Apply hydraulic system oil to O-ring.
4. Install fitting (C) into port until fitting is hand tight.
5. Torque fitting (C) according to values in Table 5.12 *O-Ring Boss (ORB) Hydraulic Fittings (Non-Adjustable)*, page 104.
6. Check final condition of fitting.

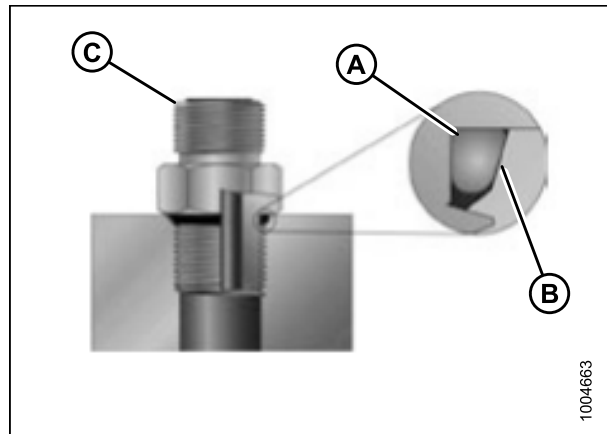

Figure 5.13: Hydraulic Fitting

Table 5.12 O-Ring Boss (ORB) Hydraulic Fittings (Non-Adjustable)

SAE Dash Size	Thread Size (in.)	Torque Value ⁵	
		N·m	ft·lbf (*in·lbf)
-2	5/16–24	6–7	*53–62
-3	3/8–24	12–13	*106–115
-4	7/16–20	19–21	14–15
-5	1/2–20	21–33	15–24
-6	9/16–18	26–29	19–21
-8	3/4–16	46–50	34–37
-10	7/8–14	75–82	55–60
-12	1-1/16–12	120–132	88–97
-14	1-3/8–12	153–168	113–124
-16	1-5/16–12	176–193	130–142
-20	1-5/8–12	221–243	163–179
-24	1-7/8–12	270–298	199–220
-32	2-1/2–12	332–365	245–269

5. Torque values shown are based on lubricated connections as in reassembly.

5.1.7 O-Ring Face Seal (ORFS) Hydraulic Fittings

1. Check components to ensure that sealing surfaces and fitting threads are free of burrs, nicks, scratches, or any foreign material.



Figure 5.14: Hydraulic Fitting

2. Apply hydraulic system oil to O-ring (B).
3. Align tube or hose assembly so that flat face of sleeve (A) or (C) comes in full contact with O-ring (B).
4. Thread tube or hose nut (D) until hand-tight. The nut should turn freely until it is bottomed out.
5. Torque fittings according to values in Table 5.13 *O-Ring Face Seal (ORFS) Hydraulic Fittings*, page 106.

NOTE:

If applicable, hold hex on fitting body (E) to prevent rotation of fitting body and hose when tightening fitting nut (D).

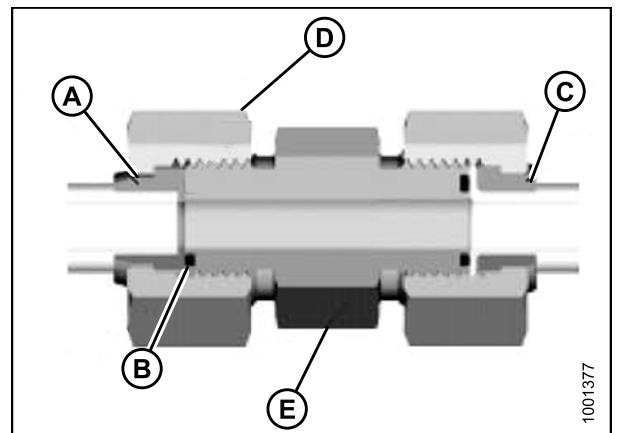

Figure 5.15: Hydraulic Fitting

6. Use three wrenches when assembling unions or joining two hoses together.
7. Check final condition of fitting.

REFERENCE

Table 5.13 O-Ring Face Seal (ORFS) Hydraulic Fittings

SAE Dash Size	Thread Size (in.)	Tube O.D. (in.)	Torque Value ⁶	
			N·m	ft·lbf
-3	Note ⁷	3/16	–	–
-4	9/16	1/4	25–28	18–21
-5	Note ⁷	5/16	–	–
-6	11/16	3/8	40–44	29–32
-8	13/16	1/2	55–61	41–45
-10	1	5/8	80–88	59–65
-12	1-3/16	3/4	115–127	85–94
-14	Note ⁷	7/8	–	–
-16	1-7/16	1	150–165	111–122
-20	1-11/16	1-1/4	205–226	151–167
-24	1–2	1-1/2	315–347	232–256
-32	2-1/2	2	510–561	376–414

6. Torque values and angles shown are based on lubricated connection as in reassembly.

7. O-ring face seal type end not defined for this tube size.

5.1.8 Tapered Pipe Thread Fittings

Assemble pipe fittings as follows:

1. Check components to ensure that fitting and port threads are free of burrs, nicks and scratches, or any form of contamination.
2. Apply pipe thread sealant (paste type) to external pipe threads.
3. Thread fitting into port until hand-tight.
4. Torque connector to appropriate torque angle. The Turns From Finger Tight (TFFT) values are shown in Table [5.14 Hydraulic Fitting Pipe Thread, page 107](#). Make sure that tube end of a shaped connector (typically 45° or 90°) is aligned to receive incoming tube or hose assembly. Always finish alignment of fitting in tightening direction. Never back off (loosen) pipe threaded connectors to achieve alignment.
5. Clean all residue and any excess thread conditioner with appropriate cleaner.
6. Assess final condition of fitting. Pay special attention to possibility of cracks to port opening.
7. Mark final position of fitting. If a fitting leaks, disassemble fitting and check for damage.

NOTE:

Over-torque failure of fittings may not be evident until fittings are disassembled.

Table 5.14 Hydraulic Fitting Pipe Thread

Tapered Pipe Thread Size	Recommended T.F.F.T	Recommended F.F.F.T
1/8-27	2-3	12-18
1/4-18	2-3	12-18
3/8-18	2-3	12-18
1/2-14	2-3	12-18
3/4-14	1.5-2.5	12-18
1-11 1/2	1.5-2.5	9-15
1 1/4-11 1/2	1.5-2.5	9-15
1 1/2-11 1/2	1.5-2.5	9-15
2-11 1/2	1.5-2.5	9-15

REFERENCE

5.2 Conversion Chart

Table 5.15 Conversion Chart

Quantity	SI Units (Metric)		Factor	Inch-Pound Units	
	Unit Name	Abbreviation		Unit Name	Abbreviation
Area	hectares	ha	$\times 0.4047 =$	acres	acres
Flow	liters per minute	L/min	$\times 3.7854 =$	US gallons per minute	gpm
Force	Newtons	N	$\times 4.4482 =$	pounds force	lbf
Length	millimeters	mm	$\times 25.4 =$	inch	in.
	meters	m	$\times 0.305 =$	foot	ft.
Power	kilowatts	kW	$\times 0.7457 =$	horsepower	hp
Pressure	kilopascals	kPa	$\times 6.8948 =$	pounds per square inch	psi
	megapascals	MPa	$\times .00689 =$		
	bar (Non-SI)	bar	$\div 14.5038 =$		
Torque	Newton meters	N·m	$\times 1.3558 =$	pound feet or foot pounds	ft·lbf
	Newton meters	N·m	$\times 0.1129 =$	pound inches or inch pounds	in·lbf
Temperature	Celsius	°C	$(^{\circ}\text{F}-32) \times 0.56 =$	degrees Fahrenheit	°F
Velocity	meters per minute	m/min	$\times 0.3048 =$	feet per minute	ft/min
	meters per second	m/s	$\times 0.3048 =$	feet per second	ft/s
	kilometers per hour	km/h	$\times 1.6063 =$	miles per hour	mph
Volume	liters	L	$\times 3.7854 =$	US gallons	US gal
	milliliters	ml	$\times 29.5735 =$	ounces	oz.
	cubic centimeters	cm ³ or cc	$\times 16.3871 =$	cubic inches	in. ³
Weight	kilograms	kg	$\times 0.4536 =$	pounds	lb.

REFERENCE

5.3 Definitions

The following terms and acronyms may be used in this manual.

Term	Definition
API	American Petroleum Institute
ASTM	American Society of Testing and Materials
Bolt	A headed and externally threaded fastener that is designed to be paired with a nut
Cab-forward	Windrower operation with Operator and cab facing in direction of travel
CDM	Cab display module on a self-propelled windrower
Center-link	A hydraulic cylinder link between header and machine to which it is attached: It is used to change header angle
CGVW	Combined vehicle gross weight
DWA	Double Windrow Attachment
ECM	Engine control module
ECU	Electronic control unit
Engine-forward	Windrower operation with Operator and engine facing in direction of travel
Export header	Header configuration typical outside North America
Finger tight	Finger tight is a reference position where sealing surfaces or components are making contact with each other and fitting has been tightened to a point where fitting is no longer loose
FFFT	Flats from finger tight
GSL	Ground speed lever
GSS	Grass Seed Special
GVW	Gross vehicle weight
Hard joint	A joint made with the use of a fastener where joining materials are highly incompressible
Header	A machine that cuts and lays crop into a windrow and is attached to a self-propelled windrower
Hex key	A hex key or Allen key (also known by various other synonyms) is a tool of hexagonal cross-section used to drive bolts and screws that have a hexagonal socket in head (internal-wrenching hexagon drive)
hp	Horsepower
ISC	Intermediate Speed Control
JIC	Joint Industrial Council: A standards body that developed standard sizing and shape for original 37° flared fitting
M-Series windrower	MacDon M105, M150, M155, M155E4, M200, and M205 windrowers
M1-Series windrower	MacDon M1170 and M1240 windrowers
n/a	Not applicable
Nut	An internally threaded fastener that is designed to be paired with a bolt

REFERENCE

Term	Definition
N-DETENT	The slot opposite the NEUTRAL position on operator's console
North American header	Header configuration typical in North America
NPT	National Pipe Thread: A style of fitting used for low pressure port openings Threads on NPT fittings are uniquely tapered for an interference fit
ORB	O-ring boss: A style of fitting commonly used in port opening on manifolds, pumps, and motors
ORFS	O-ring face seal: A style of fitting commonly used for connecting hoses and tubes This style of fitting is also commonly called ORS, which stands for O-ring seal
rpm	Revolutions per minute
R-Series header	MacDon R80 and R85 rotary disc headers
RoHS (Reduction of Hazardous Substances)	A directive by the European Union to restrict use of certain hazardous substances (such as hexavalent chromium used in some yellow zinc platings)
SAE	Society of Automotive Engineers
Screw	A headed and externally threaded fastener that threads into preformed threads or forms its own thread in one of mating parts
Self-Propelled (SP) Windrower	Self-propelled machine consisting of a power unit with a header
Soft joint	A joint made with use of a fastener where joining materials are compressible or experience relaxation over a period of time
Truck	A four-wheel highway/road vehicle weighing no less than 3400 kg (7500 lb.)
Tension	Axial load placed on a bolt or screw, usually measured in Newtons (N) or pounds (lb.)
TFFT	Turns from finger tight
Torque	The product of a force X lever arm length, usually measured in Newton-meters (N·m) or foot-pounds (ft·lbf)
Torque angle	A tightening procedure where fitting is assembled to a precondition (finger tight) and then nut is turned further a number of degrees or a number of flats to achieve its final position
Torque-tension	The relationship between assembly torque applied to a piece of hardware and axial load it induces in bolt or screw
Washer	A thin cylinder with a hole or slot located in the center that is to be used as a spacer, load distribution element, or a locking mechanism
Windrower	Power unit of a self-propelled header
WCM	Windrower control module

Predelivery Checklist

Perform these checks and adjustments before delivering the machine to your Customer. If adjustments are required, refer to the appropriate page number in this manual. The completed Checklist should be retained by either the Operator or the Dealer.

WARNING

Do **NOT** operate the machine with the driveshields open. High speed rotating components may throw debris and could result in death or serious injury.

CAUTION

Carefully follow the instructions given. Be alert for safety-related messages that bring your attention to hazards and unsafe practices.

Header Serial Number:

Table 1 R85 Rotary Disc 16-Foot Self-Propelled Windrower Header Predelivery Checklist

✓	Item	Reference
	Check for shipping damage or missing parts. Be sure all shipping dunnage is removed.	—
	Check for loose hardware. Tighten to required torque if applicable.	5.1 Torque Specifications, page 95
	Check main drive belt tension.	4.1 Checking Drive Belts, page 79
	Check auger drive belt tension.	4.1 Checking Drive Belts, page 79
	Check header angle. Set center-link to middle of adjustment range.	3.11 Attaching Header to an M-Series Windrower, page 30
	Check header float: 426–471 N (95–105 lbf).	4.2 Checking Header Float, page 81
	Check if header is level.	4.3 Checking Header Level, page 82
	Check if side forming shields are evenly set to desired position.	3.10 Installing Forming Shield, page 27
	Check if rear fluffer deflector is about halfway down.	3.10 Installing Forming Shield, page 27
	Check if swath baffle lever is set about halfway.	3.7 Unpacking Curtains, page 18
	Check if gauge rollers/skid shoes are evenly set.	4.5 Checking Gauge Rollers or Skid Shoes, page 87
	Check bevel gearbox lube level.	4.6 Preparing the Bevel Gearbox, page 88
	Check if bevel gearbox breather is installed.	4.6 Preparing the Bevel Gearbox, page 88
	Check conditioner gearbox lube level.	4.7 Preparing the Conditioner Gearbox, page 89
	Check if conditioner gearbox breather is installed.	4.7 Preparing the Conditioner Gearbox, page 89
	Grease all bearings and drivelines.	3.15 Header Lubrication, page 73
	Check conditioner roll gap and timing.	4.4 Checking Conditioner Rolls, page 84
	Check if roll intermesh hardware is securely tightened.	4.4 Checking Conditioner Rolls, page 84

PREDELIVERY CHECKLIST

✓	Item	Reference
	Check if cutterbar curtains are hanging properly.	3.7 Unpacking Curtains, page 18
	Check hydraulic hose and wiring harness routing.	—
	Check cutterbar area carefully for loose parts and hardware on the cutterbar.  WARNING These objects can be ejected with considerable force when the machine is started, and may result in serious injury or machine damage.	—
Run-Up Procedure		4.10 Running up the Header, page 93
	Check hydraulic hose and wiring harness routing for clearance when raising or lowering header.	—
	Check that hazard lights are functional.	4.8 Checking Lights, page 91
Post Run-Up Check. Stop Engine.		
	Check belt drives for idler alignment and heated bearings.	4.1 Checking Drive Belts, page 79
	Check for hydraulic leaks.	—
	Check that header manuals are in windrower cab storage compartment.	4.9 Checking Manuals, page 92

Date Checked:

Checked by:

MacDon Industries Ltd.

680 Moray Street
Winnipeg, Manitoba
Canada R3J 3S3
t. (204) 885-5590
f. (204) 832-7749

MacDon, Inc.

10708 N. Pomona Avenue
Kansas City, Missouri
United States 64153-1924
t. (816) 891-7313
f. (816) 891-7323

MacDon Australia Pty. Ltd.

A.C.N. 079 393 721
P.O. Box 243, Suite 3, 143 Main Street
Greensborough, Victoria, Australia 3088
t. 03 9432 9982
f. 03 9432 9972

LLC MacDon Russia Ltd.

123317 Moscow, Russia
10 Presnenskaya nab, Block C
Floor 5, Office No. 534, Regus Business Centre
t. +7 495 775 6971
f. +7 495 967 7600

CUSTOMERS

MacDon.com

DEALERS

Portal.MacDon.com

Trademarks of products are the marks of their respective manufacturers and/or distributors.

Printed in Canada