

R216

Rotary Disc Header for Windrowers

Unloading and Assembly Instructions

262271 Revision A

Original Instruction

R216 Rotary Disc Header

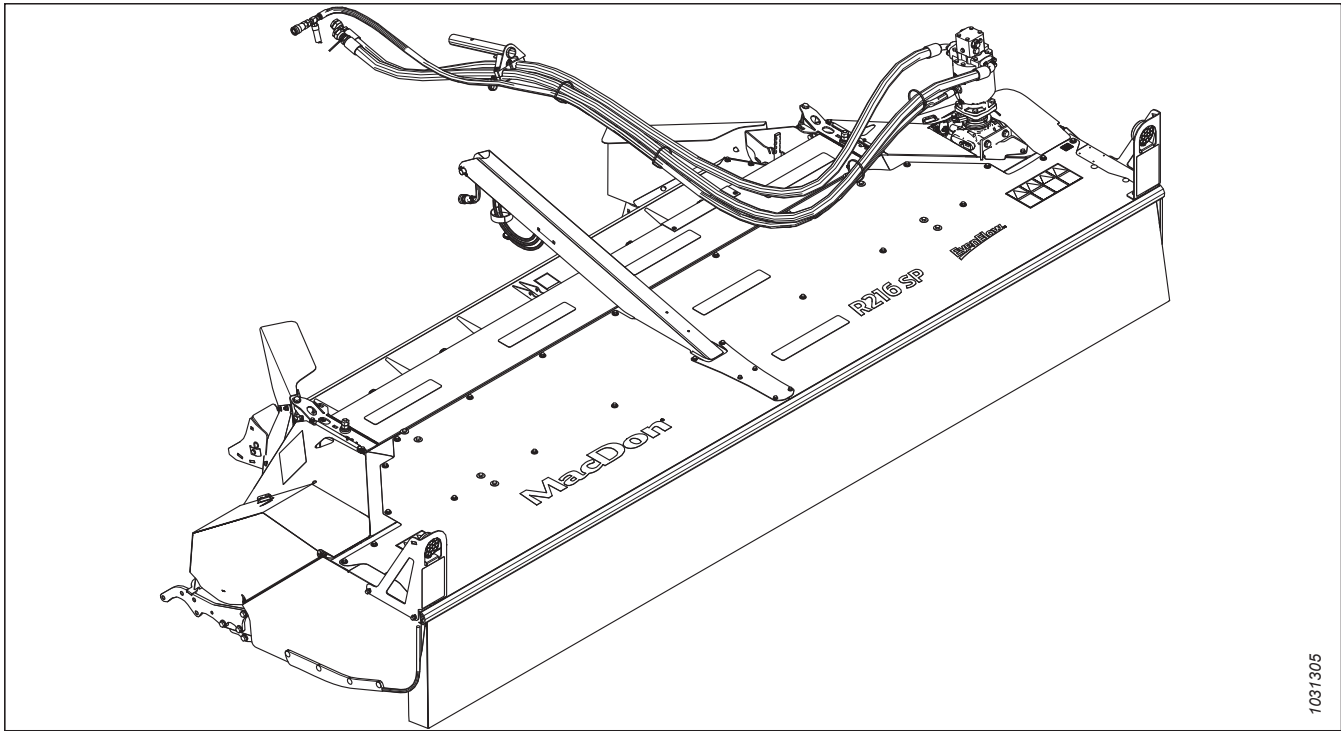

Published September 2023

© 2023 MacDon Industries, Ltd.

The information in this publication is based on the information available and in effect at the time of printing. MacDon Industries, Ltd. makes no representation or warranty of any kind, whether expressed or implied, with respect to the information in this publication. MacDon Industries, Ltd. reserves the right to make changes at any time without notice.

Introduction

This document describes the unloading, setup, and predelivery requirements for the MacDon R216 Rotary Disc Header, including a Grass Seed (GSS) version.

To ensure the Customer receives all of the performance and safety benefits of this product, carefully follow the unloading and assembly procedure from the beginning through to the end.

Read all of the material provided before attempting to unload, assemble, or use the machine.

Retain this instruction for future reference.

NOTE:

Keep your MacDon publications up-to-date. The most current version can be downloaded from our website (www.macdon.com) or from our Dealer-only site (<https://portal.macdon.com>) (login required).

If the shipment is damaged or is missing parts, contact the following according to your region:

- North America: shortageanddamage@macdon.com
- Australia: service@macdon.com.au
- Brazil: garantia-brasil@macdon.com
- Europe (except Russia): MarketingEurope@macdon.com
- Russia: shortageanddamage@macdon.com

Conventions

The following conventions are used in this document:

- Right and left are determined from the operator's position. The front of the rotary disc header faces the crop.
- Unless otherwise noted, use the standard torque values provided in this manual.

NOTE:

This manual is currently available in English only.

Summary of Changes

At MacDon, we're continuously making improvements, and occasionally these improvements affect product documentation. The following list provides an account of major changes from the previous version of this document.

Section	Summary of Change	Internal Use Only
—	Removed topics concerning the Feed Roll Drive.	ECN 63932
<i>4.1.4 Unpacking Hydraulic Hoses and Electrical Harness, page 19</i>	Updated procedure to include instructions for M2260 Windrowers.	Product Support
<i>5 Attaching Rotary Disc Header to Windrower, page 37</i>	Added procedures for M2 Series and M Series Windrowers.	Technical Publications
<i>5.1 Attaching R2 Series Rotary Disc Header to M2 Series Windrower, page 37</i>	Added topic.	Technical Publications
<i>5.1.1 Connecting R2 Series Rotary Disc Header Hydraulic and Electrical Components – M2170 Windrower, page 44</i>	Added topic.	Technical Publications
<i>5.1.2 Connecting R2 Series Rotary Disc Header Hydraulic and Electrical Systems – M2260 Windrower, page 50</i>	Added topic and subtopics.	Technical Publications
<i>5.2 Calibrating M2 Series Windrower and Header on HarvestTouch™ Display, page 66</i>	Added topic.	Technical Publications
<i>5.3 Calibrating Knife Drive on HarvestTouch™ Display – M2 Series Windrowers, page 67</i>	Added topic.	Technical Publications
<i>5.4 Calibrating Header Position Sensors on HarvestTouch™ Display – M2 Series Windrowers, page 71</i>	Added topic.	Technical Publications
<i>5.7 Calibrating Header Position Sensors on Harvest Performance Tracker Display – M1 Series Windrowers, page 100</i>	Added topic.	Technical Publications
<i>5.9 Attaching R2 Series Rotary Disc Header to M155 SP Windrower, page 121</i>	Added topic and subtopics.	Technical Publications
<i>5.10 Attaching R2 Series Rotary Disc Header to M155E4 SP Windrower, page 135</i>	Added topic and subtopics.	Technical Publications
<i>6 Unpacking the Curtain, page 151</i>	Updated step to include instructions for M2 Series Windrowers.	Technical Publications
<i>7.1 Installing Skid Shoes or Gauge Rollers, page 153</i>	Updated table.	ECN 63963
<i>7.2 Installing Hydraulic Drive Kit – For Headers Shipped without Hydraulic Drive Only, page 154</i>	Updated table.	Product Support
<i>7.3 Installing Grass Seed Anti-Shatter Shield Kit – Grass Seed Ready Headers Only, page 155</i>	Removed table.	Technical Publications
<i>8.1 Lubrication Locations – Standard Headers, page 158</i>	Updated lubrication locations.	ECN 63963
<i>9.2.1 Checking Float – M1 Series and M2 Series Windrowers, page 164</i>	Updated topic for M2 Series Windrowers.	Technical Publications
<i>9.2.2 Setting Float – M2 Series Windrowers, page 164</i>	Added topic.	Technical Publications
<i>9.3 Activating Grass Seed Option – M2 Series Windrowers, page 171</i>	Added topic.	Technical Publications
<i>9.6 Checking and Adding Oil in Conditioner Timing Gearbox – Standard Header, page 178</i>	Updated illustration.	ECN 63963

Section	Summary of Change	Internal Use Only
<i>10.1 Starting Engine – M1 Series and M2 Series Windrowers, page 187</i>	Updated topic for M2 Series Windrowers.	Technical Publications
<i>10.3 Engaging and Disengaging Header Safety Props – M1 Series and M2 Series Windrowers, page 196</i>	Updated topic for M2 Series Windrowers.	Technical Publications
<i>10.5 Leveling Header – M2 Series Windrower, page 200</i>	Added topic.	Technical Publications
<i>10.8 Removing and Restoring Float for M2 Series Windrowers, page 207</i>	Added topic.	Technical Publications
<i>10.9 Removing and Restoring Float for M1 Series Windrowers, page 209</i>	Moved topic to current location.	Technical Publications
<i>10.14.3 O-Ring Boss Hydraulic Fittings – Adjustable, page 221</i>	Updated table.	ECN 64539
<i>10.14.4 O-Ring Boss Hydraulic Fittings – Non-Adjustable, page 222</i>	Updated table.	ECN 64539
<i>10.14.5 O-Ring Face Seal Hydraulic Fittings, page 223</i>	Corrected table.	Technical Publications
<i>Predelivery Checklist, page 229</i>	Updated predelivery checklist.	Technical Publications

TABLE OF CONTENTS

Introduction	i
Summary of Changes.....	ii
Chapter 1: Safety	1
1.1 Safety Alert Symbols	1
1.2 Signal Words	2
1.3 General Safety	3
1.4 Hydraulic Safety	5
1.5 Welding Precaution	6
1.6 Safety Signs	7
Chapter 2: Unloading Header from Trailer – North America	9
Chapter 3: Unloading Header from Shipping Container – Export	11
Chapter 4: Assembling Header.....	15
4.1 Preparing Header for Assembly.....	15
4.1.1 Removing Shipping Wire from Bottom of Header – Standard Headers Only.....	15
4.1.2 Lowering the Header	15
4.1.3 Removing Forming Shield Crate – Standard Headers Only	18
4.1.4 Unpacking Hydraulic Hoses and Electrical Harness	19
4.1.5 Removing Shipping Stand	21
4.2 Installing Hazard/Brake Light Assembly – Standard Headers Only.....	26
4.3 Installing Manual Rear Deflectors – Standard Headers Only	28
4.4 Assembling and Installing Forming Shield.....	30
Chapter 5: Attaching Rotary Disc Header to Windrower	37
5.1 Attaching R2 Series Rotary Disc Header to M2 Series Windrower.....	37
5.1.1 Connecting R2 Series Rotary Disc Header Hydraulic and Electrical Components – M2170 Windrower	44
5.1.2 Connecting R2 Series Rotary Disc Header Hydraulic and Electrical Systems – M2260 Windrower.....	50
Auger/Rotary Disc/Draper-Ready Configuration – Quick Coupler Connections	51
Rotary Disc-Only Configuration – Hard-Plumbed Connections.....	56
Rotary Disc-Only Configuration – Quick Coupler Connections	61
5.2 Calibrating M2 Series Windrower and Header on HarvestTouch™ Display	66
5.3 Calibrating Knife Drive on HarvestTouch™ Display – M2 Series Windrowers.....	67
5.4 Calibrating Header Position Sensors on HarvestTouch™ Display – M2 Series Windrowers.....	71
5.5 Attaching R2 Series Rotary Disc Header to M1 Series Windrower	75
5.5.1 Attaching R2 Series Rotary Disc Header to M1240 Windrower	82
Routing Electrical Harness – M1240 Windrower.....	82
Connecting R2 Series Rotary Disc Header Hydraulic and Electrical Systems – M1240 Windrower	84
5.6 Calibrating Knife Drive on Harvest Performance Tracker Display – M1 Series Windrowers	97
5.7 Calibrating Header Position Sensors on Harvest Performance Tracker Display – M1 Series Windrowers	100
5.8 Attaching R2 Series Rotary Disc Header to M205 SP Windrower	103

TABLE OF CONTENTS

5.8.1 Attaching R2 Series Rotary Disc Header to M205 SP Windrower – Hydraulic Center-Link with Optional Self-Alignment.....	103
5.8.2 Attaching R2 Series Rotary Disc Header to M205 SP Windrower – Hydraulic Center-Link without Optional Self-Alignment	109
5.8.3 Connecting R2 Series Rotary Disc Header Hydraulics and Electrical Components – M205 SP Windrower	115
5.9 Attaching R2 Series Rotary Disc Header to M155 SP Windrower	121
5.9.1 Attaching R2 Series Rotary Disc Header to M155 SP Windrower – Hydraulic Center-Link with Self-Alignment.....	121
5.9.2 Attaching R2 Series Rotary Disc Header to M155 SP Windrower – Hydraulic Center-Link without Self-Alignment.....	127
5.9.3 Connecting R2 Series Rotary Disc Header Hydraulics and Electrical to M155 SP Windrower.....	133
5.10 Attaching R2 Series Rotary Disc Header to M155E4 SP Windrower	135
5.10.1 Attaching R2 Series Rotary Disc Header to M155E4 SP Windrower – Hydraulic Center-Link with Self-Alignment.....	135
5.10.2 Attaching R2 Series Rotary Disc Header to M155E4 SP Windrower – Hydraulic Center-Link without Self-Alignment.....	141
5.10.3 Connecting R2 Series Rotary Disc Header Hydraulics and Electrical – M155E4 SP Windrower.....	147
5.11 Setting the Header Cut Width	149
Chapter 6: Unpacking the Curtain.....	151
Chapter 7: Installing Other Options.....	153
7.1 Installing Skid Shoes or Gauge Rollers	153
7.2 Installing Hydraulic Drive Kit – For Headers Shipped without Hydraulic Drive Only	154
7.3 Installing Grass Seed Anti-Shatter Shield Kit – Grass Seed Ready Headers Only.....	155
Chapter 8: Lubricating Rotary Disc Header	157
8.1 Lubrication Locations – Standard Headers.....	158
8.2 Lubrication Locations – Grass Seed Headers	160
Chapter 9: Performing Predelivery Checks.....	161
9.1 Conditioner Drive Belt – Standard Header.....	161
9.1.1 Inspecting Conditioner Drive Belt.....	161
9.1.2 Adjusting Conditioner Drive Belt	162
9.2 Header Float.....	164
9.2.1 Checking Float – M1 Series and M2 Series Windrowers	164
9.2.2 Setting Float – M2 Series Windrowers	164
9.2.3 Setting Float – M1 Series Windrowers	166
9.2.4 Checking Float – M Series Windrowers	167
9.2.5 Setting Float – M Series Windrowers	168
Adjusting Float Using Drawbolts	170
9.3 Activating Grass Seed Option – M2 Series Windrowers.....	171
9.4 Activating Grass Seed Option – M1 Series Windrowers.....	173
9.5 Suspended Drum Drive.....	177

TABLE OF CONTENTS

9.5.1 Checking Suspended Drum Drive	177
9.6 Checking and Adding Oil in Conditioner Timing Gearbox – Standard Header	178
9.7 Checking and Adding Oil in Header Drive Gearbox.....	179
9.8 Checking and Adding Lubricant in Cutterbar	180
9.9 Checking Lights	183
9.10 Checking Manual Storage Case.....	184
9.11 Checking Parts in Storage Location.....	185
9.12 Running up Header	186
Chapter 10: Reference	187
10.1 Starting Engine – M1 Series and M2 Series Windrowers	187
10.2 Starting Engine – M Series Windrower.....	193
10.3 Engaging and Disengaging Header Safety Props – M1 Series and M2 Series Windrowers	196
10.4 Engaging and Disengaging Header Safety Props – M Series Self-Propelled Windrower.....	198
10.5 Leveling Header – M2 Series Windrower.....	200
10.6 Leveling Header – M1 Series Windrower.....	202
10.7 Leveling Header – M Series Windrower	204
10.8 Removing and Restoring Float for M2 Series Windrowers	207
10.9 Removing and Restoring Float for M1 Series Windrowers	209
10.10 Opening Driveshields	211
10.11 Closing Driveshields.....	213
10.12 Opening Cutterbar Curtain.....	215
10.13 Closing Cutterbar Curtain	217
10.14 Torque Specifications.....	218
10.14.1 Metric Bolt Specifications.....	218
10.14.2 Metric Bolt Specifications – Cast Aluminum.....	220
10.14.3 O-Ring Boss Hydraulic Fittings – Adjustable	221
10.14.4 O-Ring Boss Hydraulic Fittings – Non-Adjustable	222
10.14.5 O-Ring Face Seal Hydraulic Fittings	223
10.14.6 Tapered Pipe Thread Fittings	224
10.15 Conversion Chart	226
10.16 Definitions	227
Predelivery Checklist	229

Chapter 1: Safety

Understanding and consistently following these safety procedures will help to ensure the safety of those operating the machine and of bystanders.

1.1 Safety Alert Symbols

The safety alert symbol indicates important safety messages in this manual and on safety signs on the machine.

This symbol means:

- **ATTENTION!**
- **BECOME ALERT!**
- **YOUR SAFETY IS INVOLVED!**

Carefully read and follow the safety message accompanying this symbol.

Why is safety important to you?

- Accidents disable and kill
- Accidents cost
- Accidents can be avoided



Figure 1.1: Safety Symbol

1.2 Signal Words

Three signal words, **DANGER**, **WARNING**, and **CAUTION**, are used to alert you to hazardous situations. Two signal words, **IMPORTANT** and **NOTE**, identify non-safety related information.

Signal words are selected using the following guidelines:

DANGER

Indicates an imminently hazardous situation that, if it is not prevented, will result in death or serious injury.

WARNING

Indicates a potentially hazardous situation that, if it is not prevented, could result in death or serious injury. It may also be used to alert you to unsafe practices.

CAUTION

Indicates a potentially hazardous situation that, if it is not prevented, may result in minor or moderate injury. It may also be used to alert you to unsafe practices.

IMPORTANT:

Indicates a situation that, if not prevented, could result in a malfunction or damage to the machine.

NOTE:

Provides additional information or advice.

1.3 General Safety

Operating, servicing, and assembling machinery presents several safety risks. These risks can be reduced or eliminated by following the relevant safety procedures and wearing the appropriate personal protective equipment.

CAUTION

The following general farm safety precautions should be part of your operating procedure for all types of machinery.

Wear all protective clothing and personal safety devices that could be necessary for the job at hand. Do **NOT** take chances. You may need the following:

- Hard hat
- Protective footwear with slip-resistant soles
- Protective glasses or goggles
- Heavy gloves
- Wet weather gear
- Respirator or filter mask

In addition, take the following precautions:

- Be aware that exposure to loud noises can cause hearing impairment. Wear suitable hearing protection devices such as earmuffs or earplugs to help protect against loud noises.



Figure 1.2: Safety Equipment



Figure 1.3: Safety Equipment

- Provide a first aid kit in case of emergencies.
- Keep a properly maintained fire extinguisher on the machine. Familiarize yourself with its use.
- Keep young children away from machinery at all times.
- Be aware that accidents often happen when Operators are fatigued or in a hurry. Take time to consider the safest way to accomplish a task. **NEVER** ignore the signs of fatigue.

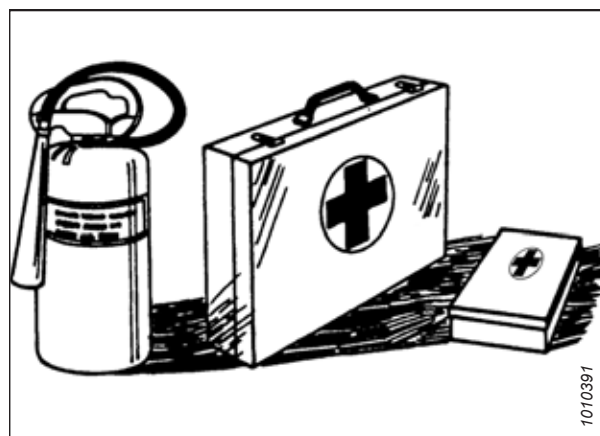

Figure 1.4: Safety Equipment

SAFETY

- Wear close-fitting clothing and cover long hair. **NEVER** wear dangling items such as hoodies, scarves, or bracelets.
- Keep all shields in place. **NEVER** alter or remove safety equipment. Ensure that the driveline guards can rotate independently of their shaft, and that they can telescope freely.
- Use only service and repair parts made or approved by the equipment manufacturer. Parts from other manufacturers may not meet the correct strength, design, or safety requirements.



Figure 1.5: Safety around Equipment

- Keep hands, feet, clothing, and hair away from moving parts. **NEVER** attempt to clear obstructions or objects from a machine while the engine is running.
- Do **NOT** modify the machine. Unauthorized modifications may impair the functionality and/or safety of the machine. It may also shorten the machine's service life.
- To avoid injury or death from the unexpected startup of the machine, **ALWAYS** stop the engine and remove the key from the ignition before leaving the operator's seat for any reason.

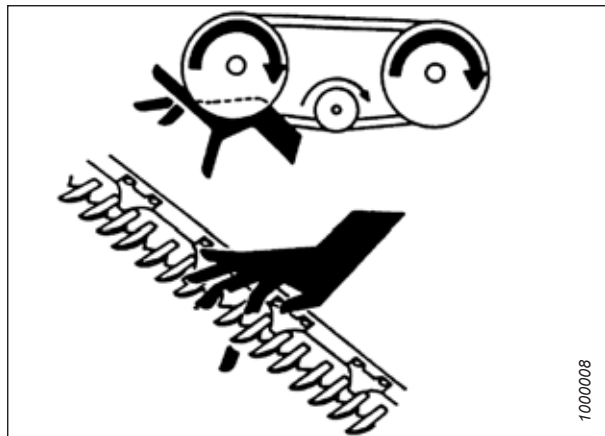

Figure 1.6: Safety around Equipment

- Keep the machine service area clean and dry. Wet and/or oily floors are slippery. Wet spots can be dangerous when working with electrical equipment. Ensure that all electrical outlets and tools are properly grounded.
- Keep the work area well-lit.
- Keep machinery clean. Straw and chaff on a hot engine are fire hazards. Do **NOT** allow oil or grease to accumulate on service platforms, ladders, or controls. Clean machines before they are stored.
- **NEVER** use gasoline, naphtha, or any volatile material for cleaning purposes. These materials may be toxic and/or flammable.
- When storing machinery, cover any sharp or extending components to prevent injury from accidental contact.



Figure 1.7: Safety around Equipment

1.4 Hydraulic Safety

Because hydraulic fluid is under extreme pressure, hydraulic fluid leaks can be very dangerous. Follow the proper safety procedures when inspecting hydraulic fluid leaks and servicing hydraulic equipment.

- Always place all hydraulic controls in **NEUTRAL** before leaving the operator's seat.
- Ensure that all of the components in the hydraulic system are kept clean and in good condition.
- Replace any worn, cut, abraded, flattened, or crimped hoses and steel lines.
- Do **NOT** attempt any makeshift repairs to hydraulic lines, fittings, or hoses by using tapes, clamps, cements, or welding. The hydraulic system operates under extremely high pressure. Makeshift repairs can fail suddenly and create hazardous conditions.



Figure 1.8: Testing for Hydraulic Leaks

- Wear proper hand and eye protection when searching for high-pressure hydraulic fluid leaks. Use a piece of cardboard as a backstop instead of your hands to isolate and identify a leak.
- If you are injured by a concentrated, high-pressure stream of hydraulic fluid, seek medical attention immediately. Serious infection or a toxic reaction can develop from hydraulic fluid piercing the skin.



Figure 1.9: Hydraulic Pressure Hazard

- Ensure that all components are tight and that steel lines, hoses, and couplings are in good condition before applying pressure to a hydraulic system.

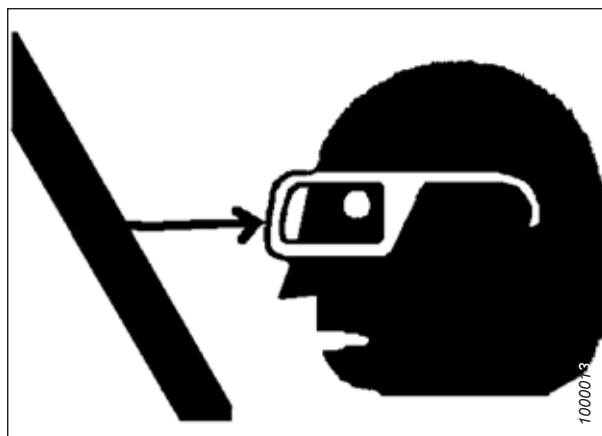

Figure 1.10: Safety around Equipment

1.5 Welding Precaution

To prevent damage to sensitive electronics, **NEVER** attempt welding on the header while it is connected to a windrower.



WARNING

NEVER attempt welding on the header while it is connected to the windrower. Severe damage to sensitive, expensive electronics can result from welding on the header while it is connected to the windrower. It can be impossible to know what effect a high current may have regarding future malfunctions or a shorter lifespan.

For further welding precautions, consult the windrower operator's manual.

If it is not practical to disconnect the header from the windrower before welding, refer to the windrower's technical manual for welding precautions detailing all electrical components that must be disconnected first for safe welding.

1.6 Safety Signs

Safety signs are decals placed on the machine where there is a risk of personal injury, or where the Operator should take extra precautions before operating the controls. They are usually yellow.

- Keep safety signs clean and legible at all times.
- Replace safety signs that are missing or illegible.
- If the original part on which a safety sign was installed is replaced, ensure that the repair part displays the current safety sign.

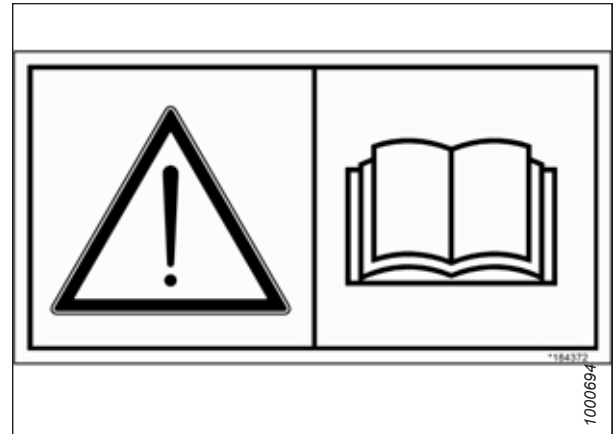

Figure 1.11: Operator's Manual Decal

Chapter 2: Unloading Header from Trailer – North America

The rotary disc header, when shipped anywhere in North America, is secured on a shipping stand. The header and the stand are unloaded from the transport vehicle using a forklift.

DANGER

Do NOT allow people to stand in the unloading area.

IMPORTANT:

The equipment used for unloading the header must meet or exceed the requirements specified below. Using inadequate equipment may result in chains breaking, damage to the machine, or the vehicle tipping.

NOTE:

Forklifts are normally rated for a load located 610 mm (24 in.) from the back end of the forks. To obtain forklift capacity at 1220 mm (48 in.), check with your forklift distributor.

Table 2.1 Lifting Vehicle

Minimum Capacity	3630 kg (8000 lb.)
Minimum Fork Length	2 m (6.5 ft.)

1. Remove the hauler's tie-down straps and chains.

WARNING

Ensure the forks are secure before moving away from the load. Stand clear when lifting the machine.

2. Approach the header with the forklift from the underside of the header and slide the forks as far as possible through four fork straps (A).

IMPORTANT:

If the load is two units wide, avoid contacting the other machine.

3. Raise the header off of the deck.

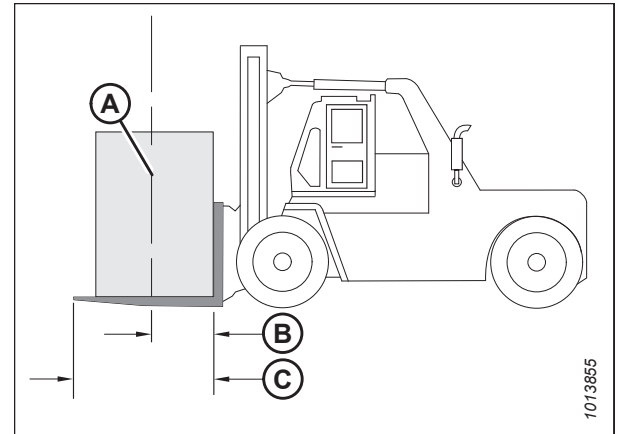

Figure 2.1: Minimum Lifting Capacity

A - Load Center of Gravity
 B - Load Center 1220 mm (48 in.) from Back of Forks
 C - Minimum Fork Length 2 m (6.5 ft.)

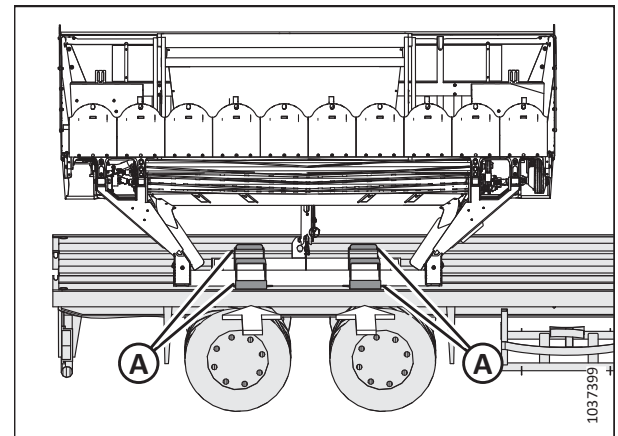

Figure 2.2: Lifting Header off Trailer

UNLOADING HEADER FROM TRAILER – NORTH AMERICA

4. Back the forklift until the header clears the trailer, the slowly lower the header until distance (A) between the ground and the header is 150 mm (6 in.).
5. Take the header to the storage or setup area.
6. Set the header down on secure, level ground. Do **NOT** lower the header into working position.
7. Check the header for any shipping damage or missing parts.
8. Proceed to Chapter 4 *Assembling Header*, page 15.

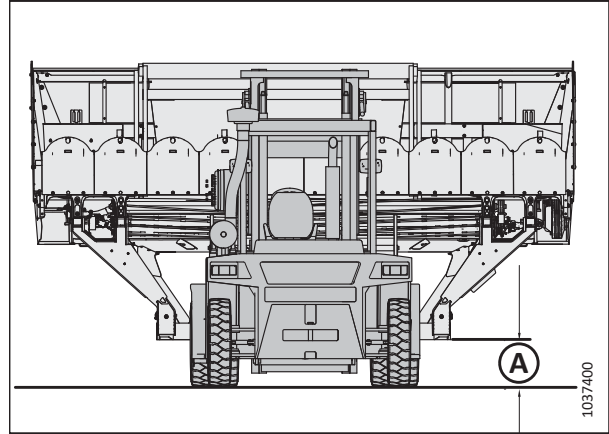

Figure 2.3: Moving Header with Forklift

Chapter 3: Unloading Header from Shipping Container – Export

Rotary disc headers, when shipped anywhere outside of North America, are transported in a shipping container. The shipping container contains up to four R216 Rotary Disc Headers placed side by side (each header is complete with a conditioner). Unload the headers one at a time, using a forklift and other unloading equipment.

DANGER

Do NOT allow people to stand in the unloading area.

NOTE:

In its shipping configuration, the R216 Rotary Disc Header has the following specifications:

- Width (A): 5.01 m (16 ft. 5 in.)
- Height (B): 2.56 m (8 ft. 5 in.)
- Depth (C): 1.43 m (4 ft. 8 in.)
- Weight: 2427 kg (5351 lbs.)

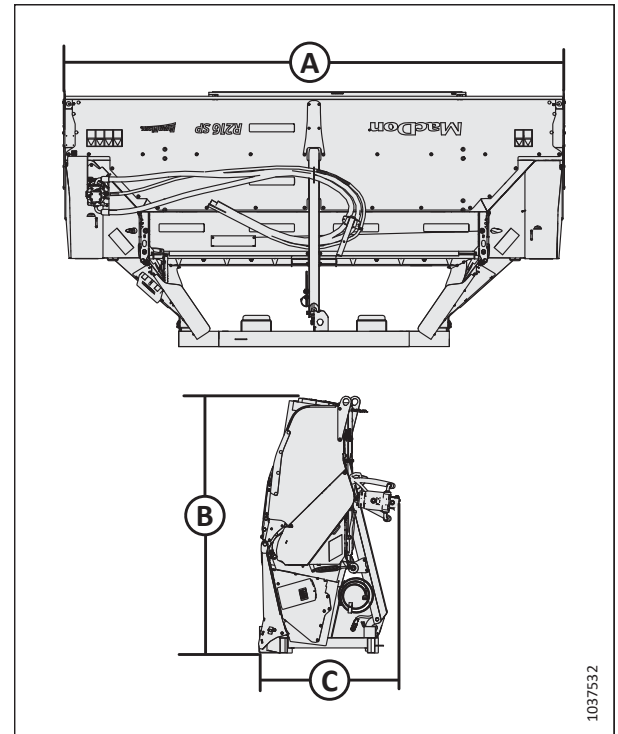

Figure 3.1: Rotary Disc Header Shipping Specifications

IMPORTANT:

The equipment used for unloading the header must meet or exceed the requirements specified below. Using inadequate equipment may result in chains breaking, damage to the machine, or the vehicle tipping.

NOTE:

Forklifts are normally rated for a load located 610 mm (24 in.) from the back end of the forks. To obtain the forklift capacity at 1.2 m (4 ft.), check with your forklift distributor.

Table 3.1 Lifting Vehicle

Minimum Capacity	3630 kg (8000 lb.)
Minimum Fork Length	2 m (6.5 ft.)

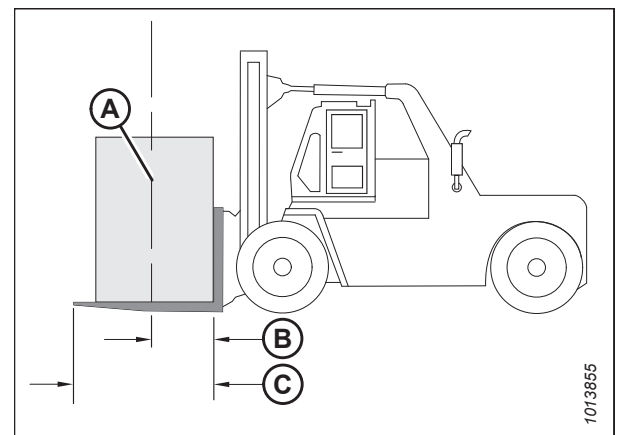

Figure 3.2: Minimum Lifting Capacity

- A - Load Center of Gravity
- B - Load Center 1.2 m (4 ft.) from Back of Forks
- C - Minimum Fork Length 2 m (6.5 ft.)

UNLOADING HEADER FROM SHIPPING CONTAINER – EXPORT

The headers are positioned inside the container as shown. Unload the headers one at a time. Start with header (A), then unload headers (B), (C), and (D).

NOTE:

The arrow in the illustration indicates the front of the shipping container.

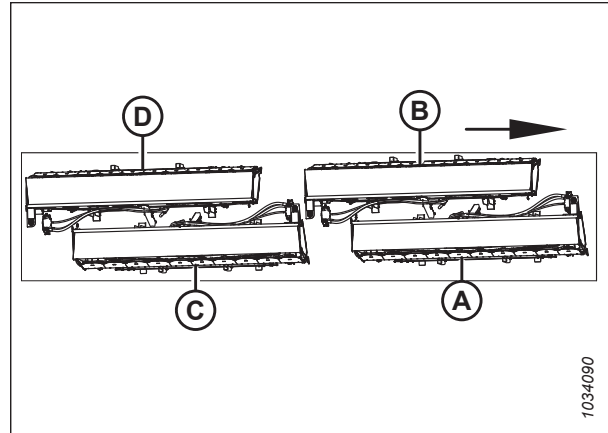

Figure 3.3: Headers in Container — View from Above

1. Move the trailer into position, then block the trailer wheels.
2. Lower the trailer storage stands.
3. Open the container doors, and remove the wood blockings and the strapping from one header at a time. This is to prevent the unit from shifting, which can cause damage.
4. Check the container floors for nails or other obstructions, and remove these obstructions if necessary.
5. Connect a chain or equivalent device (A) to the middle of shipping stand crossmember (B).

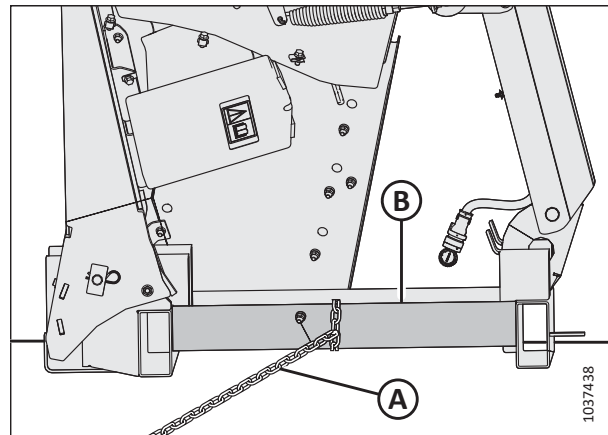

Figure 3.4: Rotary Disc Header in Shipping Container — View from Left

UNLOADING HEADER FROM SHIPPING CONTAINER – EXPORT

- Using a forklift, position shipping platform (A) at the container opening. Ensure that the platform lines up with the container floor.
- Attach a chain or equivalent device (B) secured to the outboard shipping stand to a second forklift that will pull header (C) out of the shipping container.

NOTE:

The actual shipping stand may be different than the one pictured.

- Slowly pull the header straight out of the shipping container and onto the shipping platform. Ensure that the center anchor beam is clear from the other header.

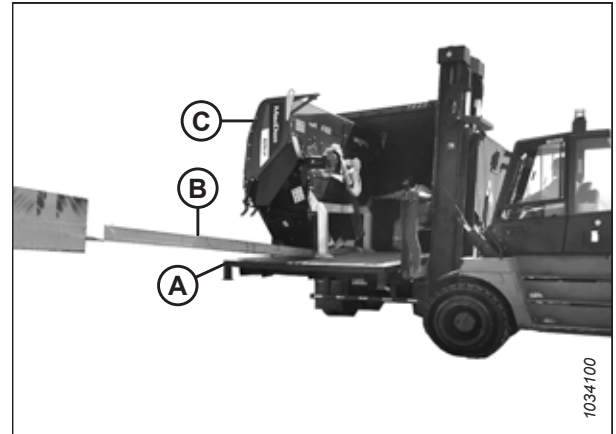

Figure 3.5: Rotary Disc Header in Container

- If the platform is resting on the container floor, lift the platform slightly to take weight off the container.
- Raise the trailer storage stands and remove the blocks from the trailer wheels.
- Slowly and carefully drive the trailer with the container away from the platform, observing all clearances.
- When the container is clear of the platform, slowly lower the platform and the header to the ground.

- Remove the chain from the shipping stand.

NOTE:

The actual shipping stand may be different from the one pictured.

- Back the forklift away from the platform and the header.
- Approach the header from its underside and slide the forks into fork straps (A) on the bottom crossmember of the shipping stand.
- Take the header to the storage or setup area.
- Set the header down on secure, level ground. Do **NOT** lower the header into working position.
- Check the header for any shipping damage or missing parts.
- Repeat Step 1, page 12 to Step 18, page 13 for the remaining headers in the shipping container.



Figure 3.6: Rotary Disc Header in Container

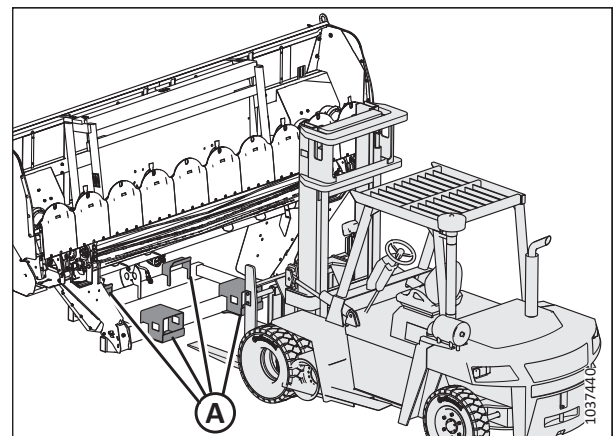

Figure 3.7: Moving Disc Header with Forklift

Chapter 4: Assembling Header

Perform the procedures in the order in which they are presented.

4.1 Preparing Header for Assembly

To prepare the header for assembly, remove all of the shipping supports and retrieve all items that were removed for shipping.

- **Standard headers:** Proceed to *4.1.1 Removing Shipping Wire from Bottom of Header – Standard Headers Only, page 15.*
- **Grass seed (GSS) headers:** Proceed to *4.1.2 Lowering the Header, page 15.*

4.1.1 Removing Shipping Wire from Bottom of Header – Standard Headers Only

Before lowering the standard R216 Rotary Disc Header into field position, remove the shipping wire that secures the forming shield crate to the bottom of the header.

1. Remove the shipping wire securing forming shield crate (B) to conditioner (C) at locations (A).

NOTE:

The shipping wire may be tied to the cutterbar instead of the conditioner.

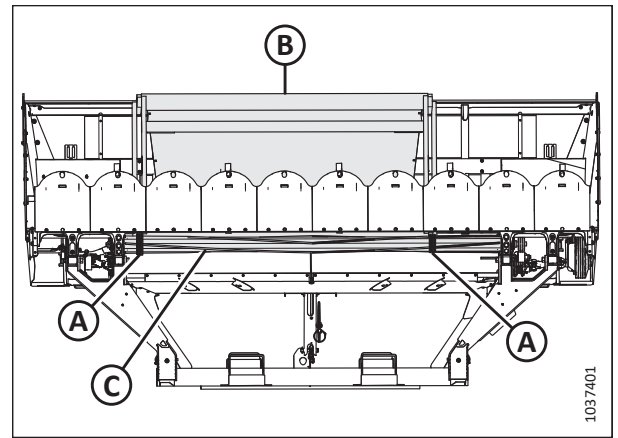

Figure 4.1: R216 Rotary Disc Header with Conditioner – Cutterbar Side

4.1.2 Lowering the Header

Lower the header into field position after lifting it off of its shipping trailer and setting it down on the ground.

CAUTION

Ensure a spreader bar is secured to the forks so that it cannot slide off the forks or toward the mast as you lower the header to the ground.

Table 4.1 Lifting Vehicle

Chain Type	Overhead lifting quality (1/2 in.)
Minimum Working Load	2270 kg (5000 lb.)

ASSEMBLING HEADER

1. Place wood blocks (A) at a distance of 420 mm (16 1/2 in.) (B) from the outboard side of each shipping stand (C).

NOTE:

The wood blocks should be 2 x 4 in. (50 mm x 100 mm) and 1–1.5 m (3–5 ft.) in length.

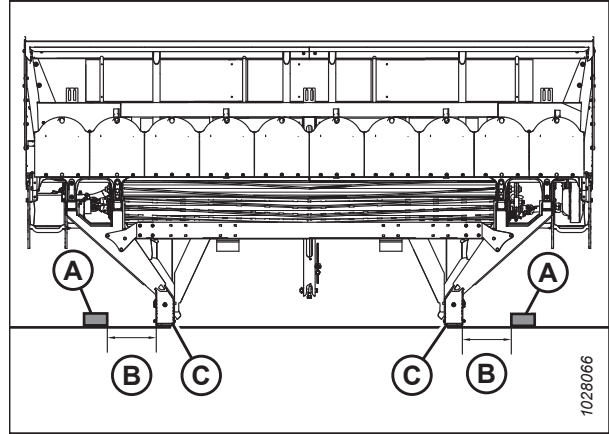

Figure 4.2: Block Placement

2. Attach spreader bar (A) to the forks of the forklift.

IMPORTANT:

The length of the spreader bar must be approximately 4.6 m (15 ft.).

3. Approach the header from its underside with the forklift.
4. Attach chains with hooks to spreader bar (A) and hook into shipping brackets (B) on both sides of the header.

! DANGER

Stand clear when lowering the rotary disc header.

IMPORTANT:

The chain length must be long enough to provide a minimum clearance of 1.2 m (4 ft.) between the header and the spreader bar.

5. Raise the forks until the lift chains are fully tensioned.

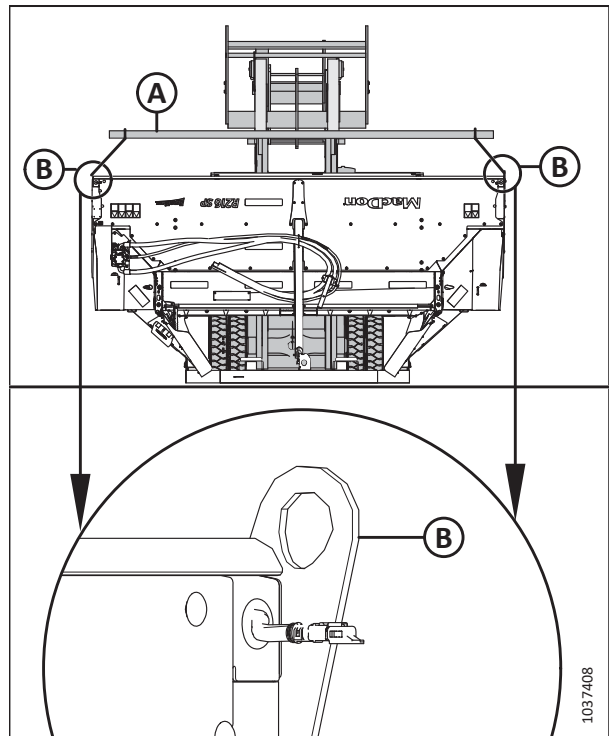

Figure 4.3: Spreader Bar Attached to Header

ASSEMBLING HEADER

6. Back up the forklift **SLOWLY**, and lower header (A) into — working position on wooden blocks (B) placed in Step 1, [page 16](#).
7. Remove the chains from the header.

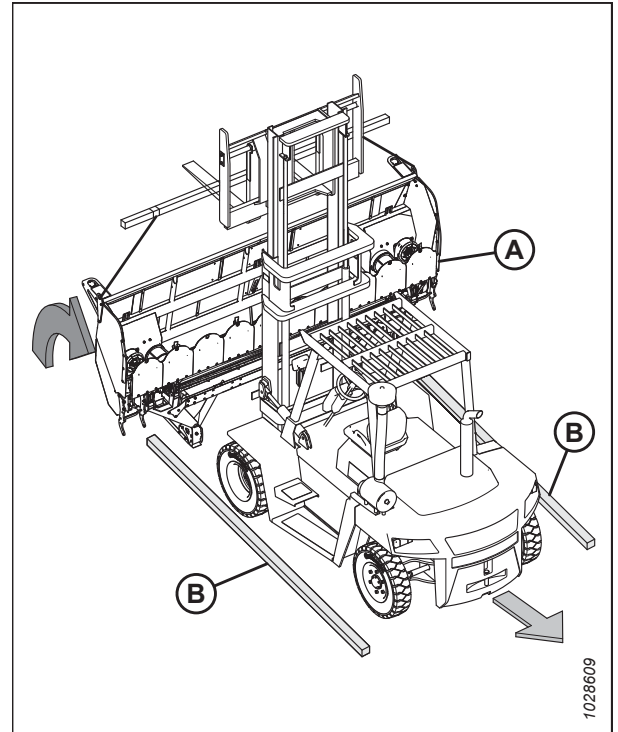

Figure 4.4: Lowering Rotary Disc Header

8. Continue to the appropriate procedure:
 - **Standard headers:** Proceed to [4.1.3 Removing Forming Shield Crate – Standard Headers Only, page 18](#).
 - **Grass Seed (GSS) headers:** Proceed to [4.1.4 Unpacking Hydraulic Hoses and Electrical Harness, page 19](#).

4.1.3 Removing Forming Shield Crate – Standard Headers Only

On standard R216 Rotary Disc Headers, the forming shield is packed in a crate and shipped inside the header. Remove this crate before assembling the header.

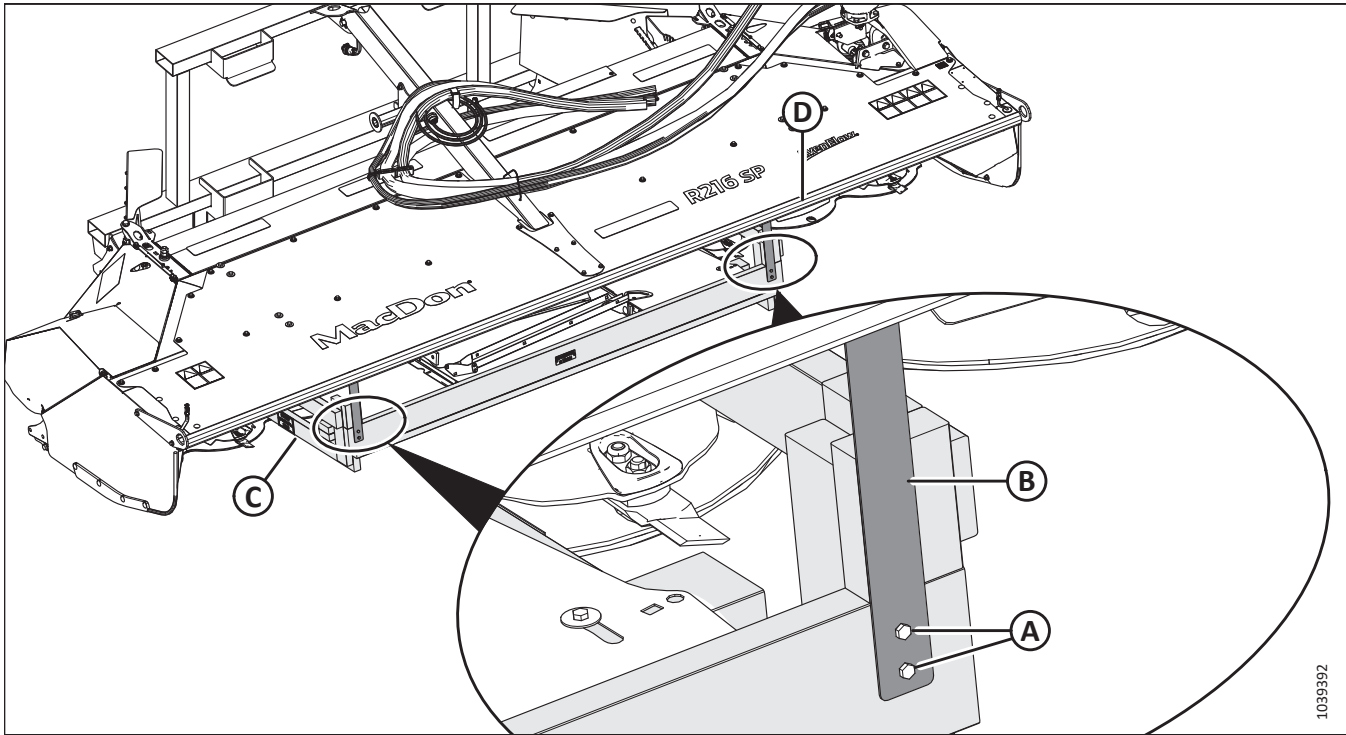
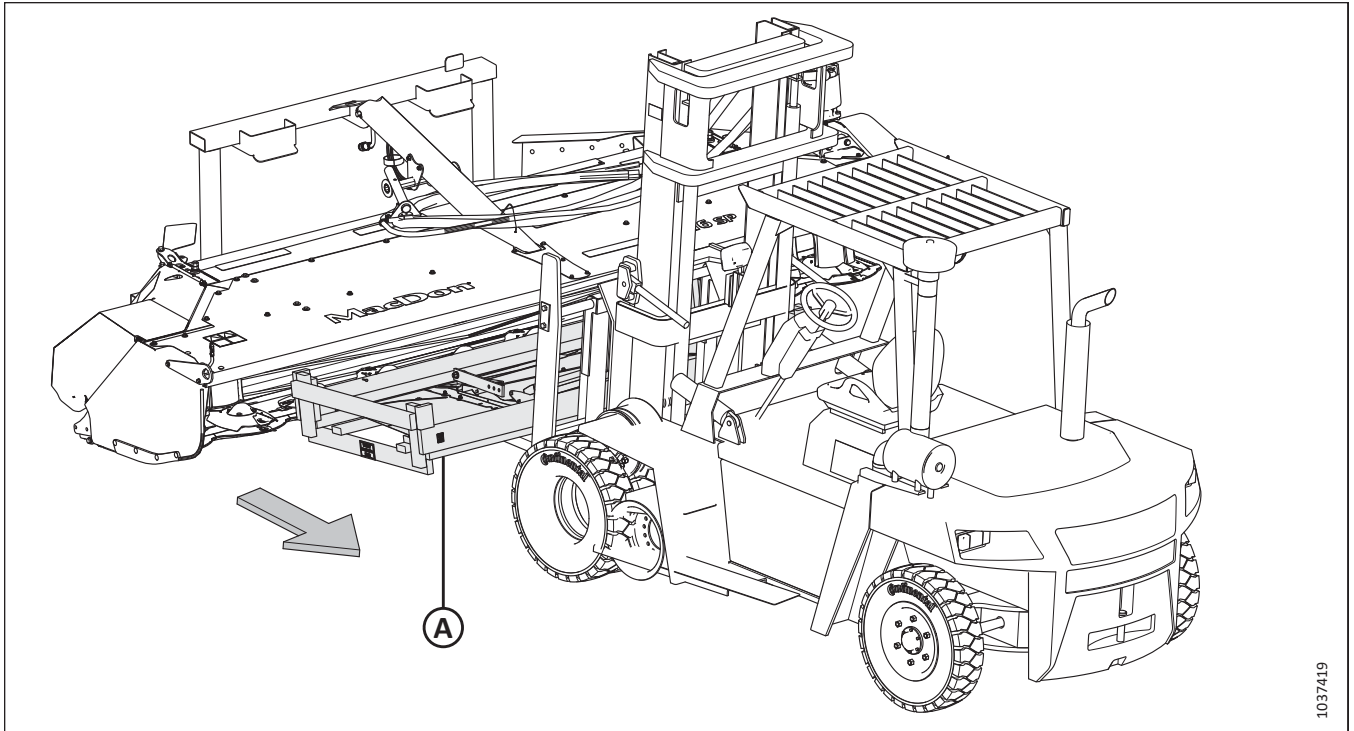

Figure 4.5: Standard R216 Rotary Disc Header with Forming Shield Crate – View from Front

1. Working from the front of the header, remove the two plastic shipping straps (not shown) securing forming shield crate (C) to the header.
2. Loosen and remove four screws (A) from two metal shipping straps (B). Remove metal shipping straps (B) by sliding them downward from behind curtain (D).
3. Discard screws (A) and metal shipping straps (B).

ASSEMBLING HEADER



1037419

Figure 4.6: Forming Shield Crate Removed from Header

4. Using a forklift, carefully slide the forks underneath forming shield crate (A) and slowly pull the crate out from inside the header.

NOTE:

The shipping weight of the forming shield crate and its contents is 80 kg (175 lb.).

IMPORTANT:

In its shipping position, the forming shield crate rests on top of the header's cutterbar. Remove the crate slowly, pull the crate straight back, and be careful not to damage the header knives with the forklift when removing the crate from the header.

4.1.4 Unpacking Hydraulic Hoses and Electrical Harness

The hydraulic hoses are secured to the header using wire and packing foam that protect the hoses during shipping. Remove this wire and packing foam before removing the shipping stand.

IMPORTANT:

If the header was shipped without a hydraulic drive motor attached, the steps in this section are not applicable. Proceed to [4.1.5 Removing Shipping Stand, page 21](#).

ASSEMBLING HEADER

1. Remove shipping wire (A) securing hose ends (B) to secured hoses (C), and remove all packing foam from the hose ends.
2. Remove all packing foam from hose support (D).

NOTE:

The packing foam is not shown in the illustration.

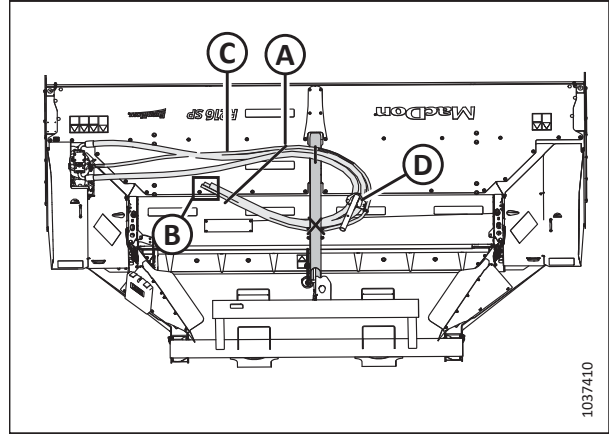

Figure 4.7: Hydraulic Hose Bundle in Shipping Position

3. Remove shipping wire cross ties (A) securing hoses (B) to center-link (C) near shipping stands (D), and pull the hoses out from under the center-link.
4. Remove shipping wire (E) from center-link (C) and move hoses (B) away from the center-link. Rest hoses (B) on top of the header.

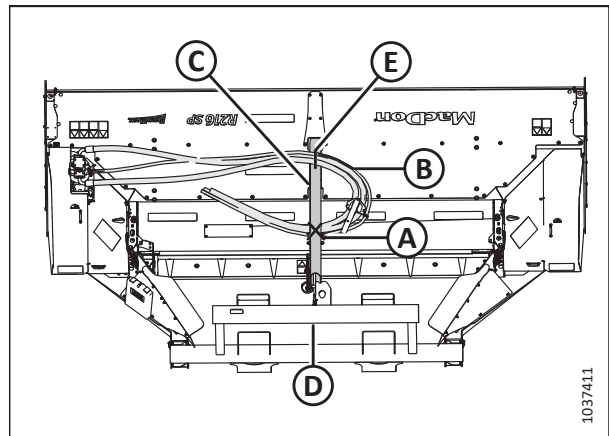

Figure 4.8: Hydraulic Hose Bundle in Shipping Position

5. **M1240 and M2260 Windrower:** Remove the shipping wire and the packing foam, and remove coiled electrical harness (A) from center-link (B). Place the harness in a safe spot until it is time to install the harness on the windrower.
6. **M205 SP Windrower:** Remove the shipping wire and remove coiled electrical harness (A) from center-link (B).

NOTE:

The harness for the M205 SP Windrower is included in a separate M205 Windrower Compatibility Kit (B7220).

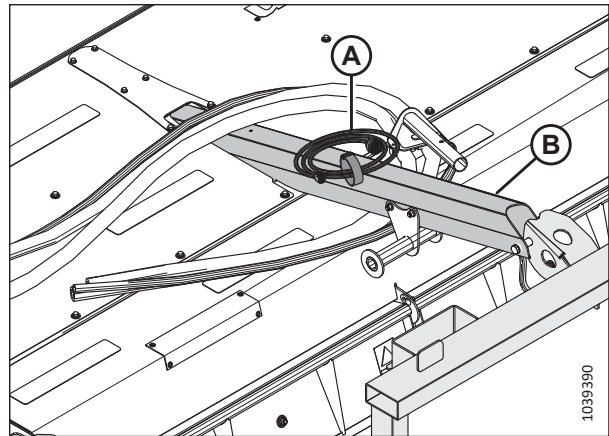

Figure 4.9: Center-Link

4.1.5 Removing Shipping Stand

Remove the shipping stand and the other supports from the header before assembly.

1. Remove four nuts and bolts (A) to remove tie-down support (B) from the center-link arm.

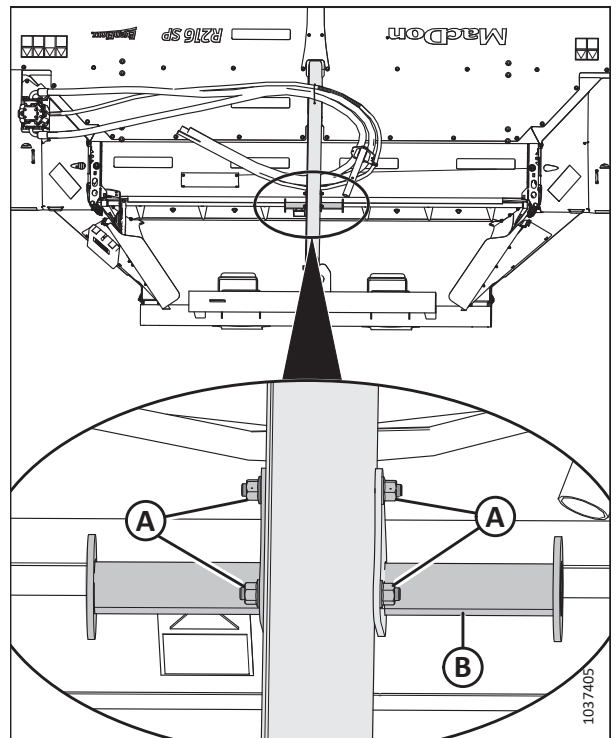

Figure 4.10: Shipping Tie-Down Support on Header

2. Support shipping stand (A) with a forklift.

NOTE:

The shipping stand weighs 145 kg (320 lbs.).

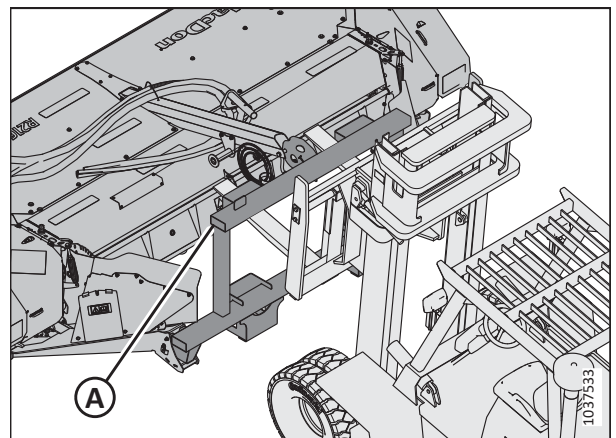

Figure 4.11: Forklift Supporting Header Shipping Stand

ASSEMBLING HEADER

3. Remove cotter and clevis pins (C) to release center-link arm (A) from shipping support (B).
4. After removing the shipping support, reinstall cotter and clevis pins (C) in the same place on the center-link arm.

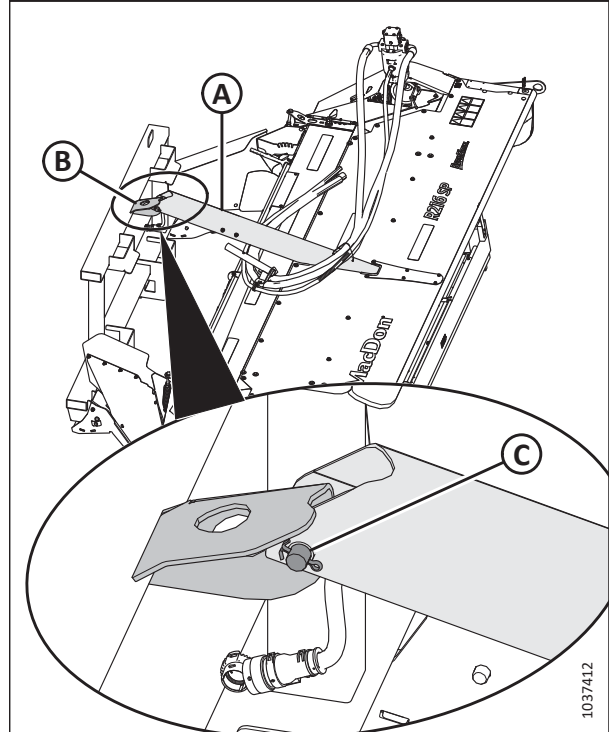

Figure 4.12: Shipping Stand – Center-Link

5. To disconnect right lift boot (A) from shipping stand (B), remove cotter pin (C), clevis pin (D), nut (E), and bolt (F).
6. After removing the shipping stand, reinstall cotter pin (C) and clevis pin (D) in the same place on lift boot (A).
7. Repeat Step 5, page 22 and Step 6, page 22 to release the left lift boot from the shipping stand.

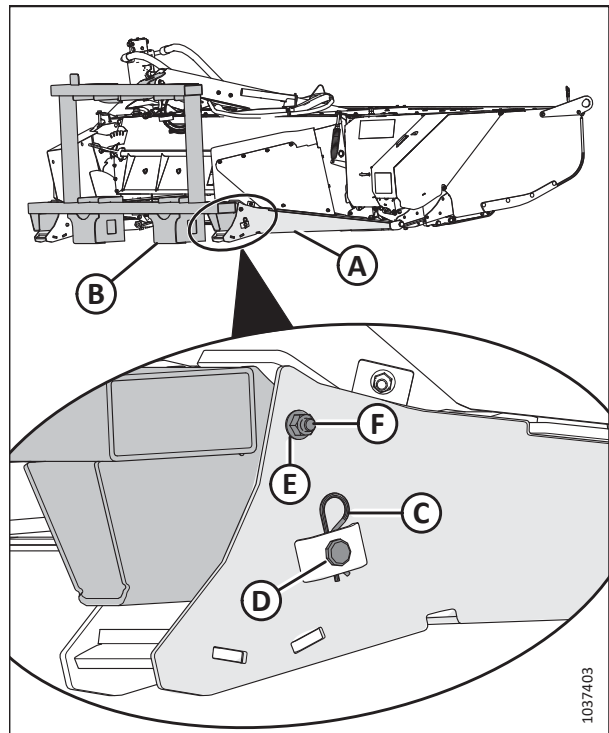

Figure 4.13: Shipping Stand – Right Side Shown, Left Side Opposite

ASSEMBLING HEADER

8. Remove shipping stand (A) from the header using the forklift.

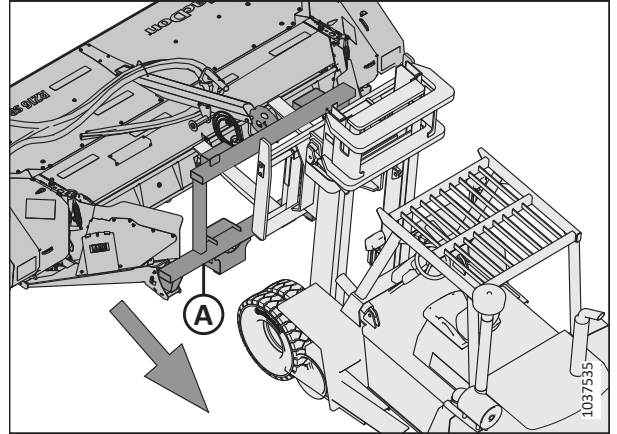

Figure 4.14: Forklift and Header Shipping Stand

9. Remove shipping wire (A) securing left driveshield handle (B) to bolt (C).

NOTE:

The driveshield is transparent in the illustration.

10. Repeat Step 9, page 23 to remove the shipping wire from the right driveshield handle.

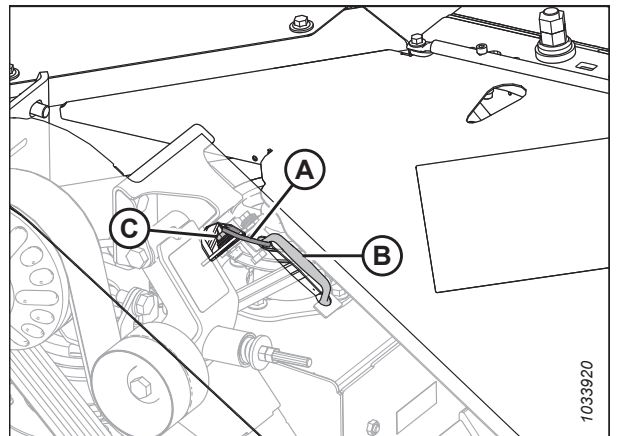

Figure 4.15: Shipping Wire on Driveshield – Left Side Shown

ASSEMBLING HEADER

11. Remove bolts (A), and discard shipping plate (B). Retain the bolts for installing the hazard/brake light assemblies on the header during the next procedure.
12. Repeat Step 11, page 24 to remove the shipping plate from the left side of the header.
13. Remove the protective film from aluminum bumper (C) at the front of the header.

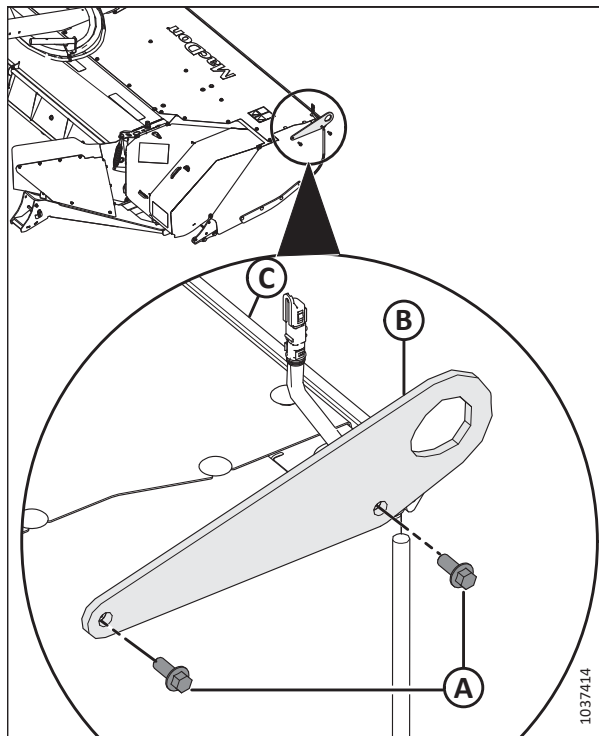

Figure 4.16: Shipping Plate – Right Side Shown, Left Side Opposite

14. **Grass seed header:** The hydraulic elbow fittings are located in a bag tied to the outside of the manual case. Retrieve the elbow fittings from their shipping location as follows:
 - a. Push down on release lever (A) on left outboard driveshield panel (B).
 - b. Using handle (F), open outboard left driveshield panel (B) by pulling it up and to the outboard side of the header.
 - c. Using handle (G), open inboard left driveshield panel (C) by pulling it up and to the inboard side of the header.
 - d. Cut the cable tie and remove the plastic bag secured to the outside of manual case (D). The plastic bag contains two hydraulic elbow fittings (E).
 - e. Retain fittings (E) for installation.

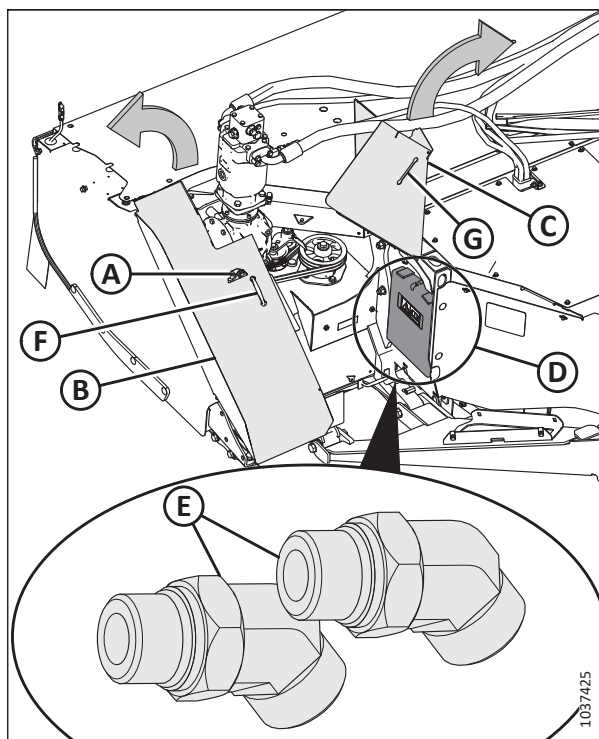

Figure 4.17: Shipping Location for Hydraulic Elbow Fittings – Grass Seed Header

ASSEMBLING HEADER

15. Proceed to the appropriate section:

- **Standard headers:** Proceed to *4.2 Installing Hazard/Brake Light Assembly – Standard Headers Only, page 26*.
- **Grass seed (GSS) headers:** Skip *4.2 Installing Hazard/Brake Light Assembly – Standard Headers Only, page 26* and *4.3 Installing Manual Rear Deflectors – Standard Headers Only, page 28*, and proceed to the next applicable section.

4.2 Installing Hazard/Brake Light Assembly – Standard Headers Only

For standard R216 Rotary Disc Headers, the brake light assemblies have been removed for shipping and must be reinstalled on the front of the header.

NOTE:

R2 Series Rotary Disc Headers configured for grass seed (GSS) do not include these light assemblies. The hazard/brake lights for GSS-ready headers are provided as part of the GSS Anti-Shatter Shield kit (B7222).

1. Remove the plastic straps securing shipping bag (A) to the inside of the forming shield crate.
2. Remove two hazard/brake light assemblies (B) from shipping bag (A).

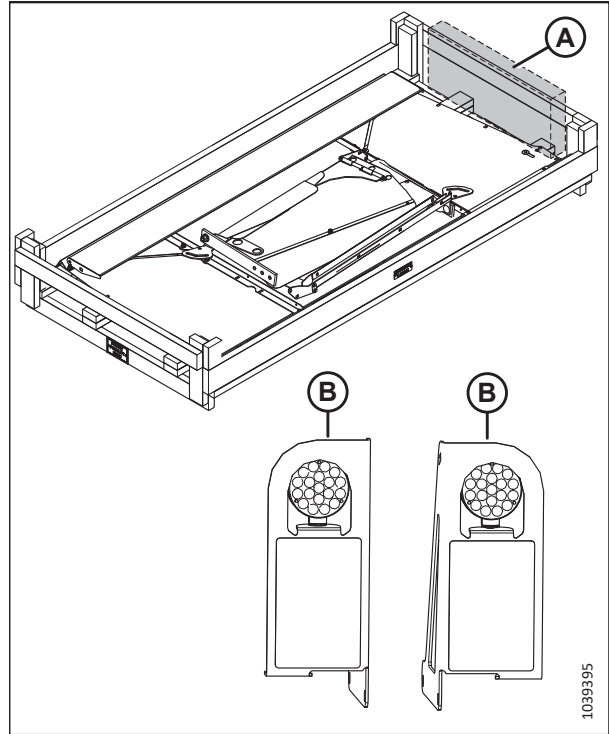

Figure 4.18: Hazard/Brake Light Assembly Shipping Location

ASSEMBLING HEADER

3. On the top right corner of the header, position hazard/brake light assembly (A) as shown, and secure it using M12 bolt (B).
4. Remove the cap from main wiring harness (D).
5. Connect hazard/brake light harness (C) to main wiring harness (D).

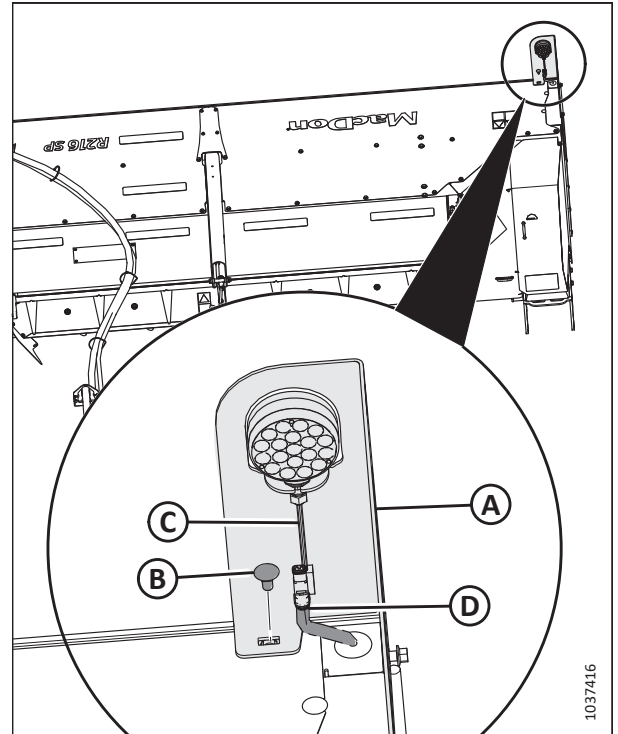

Figure 4.19: Right Hazard/Brake Light Assembly

6. Retrieve the bolts removed from the shipping plates in Step [11, page 24](#).
7. Apply medium-strength threadlocker (Loctite® 243 or equivalent) to bolt threads (A) and use the bolts to secure hazard/brake light assembly (B) to the header.
8. Torque the bolts to 91 Nm (67 lbf-ft).
9. Repeat Step [3, page 27](#) to Step [8, page 27](#) to install the second hazard/brake light assembly on the left side of the header.

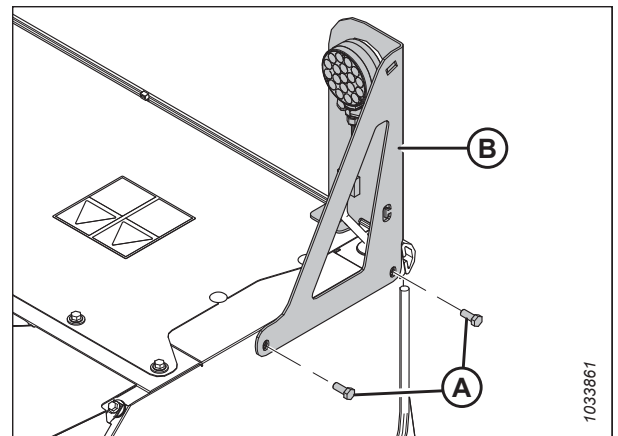

Figure 4.20: Right Hazard/Brake Light Assembly

4.3 Installing Manual Rear Deflectors – Standard Headers Only

There are four fins and two deflectors located under the baffle. The fins and deflectors require no adjustment from shipping configuration to field position.

Install the rear deflectors as follows:

1. Remove and retain hardware (A) securing deflector (B) to rear baffle (C). Remove and retain deflector (B) from the header. Repeat this step on the opposite side of the header.

NOTE:

There are three sets of hardware (A) on the baffle, but only two sets of hardware hold deflector (B) in the shipping position. Ensure that all three sets of hardware (A) are removed and retained.

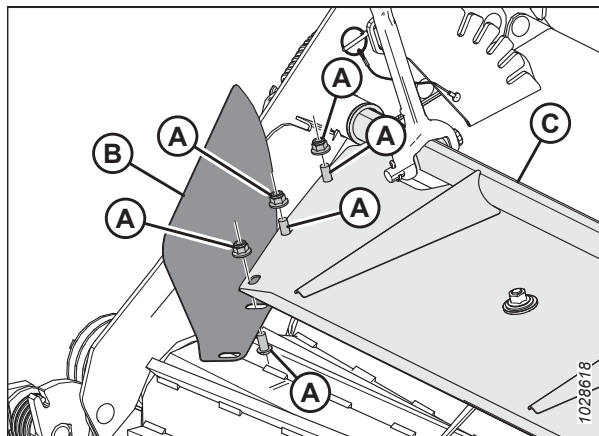

Figure 4.21: Deflector and Rear Baffle – View of baffle edge Deflector Underside, Right Side of the Header

2. Remove pin (A) from baffle handle (B), and adjust the rear baffle by placing handle (B) in the center position on baffle bracket (C).

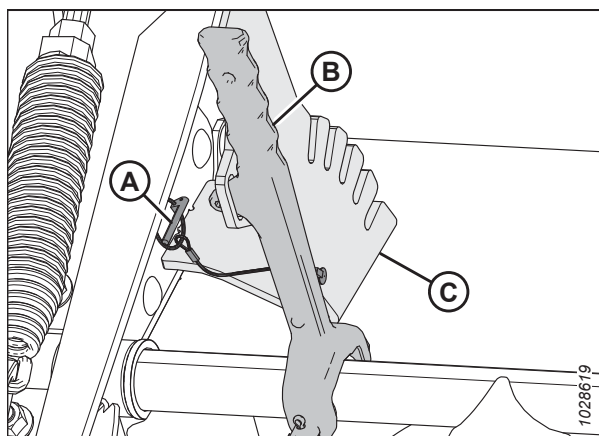

Figure 4.22: Baffle Handle and Baffle Bracket

3. Replace pin (A) in baffle handle (B) to secure the handle in the fully raised position on baffle bracket (C).

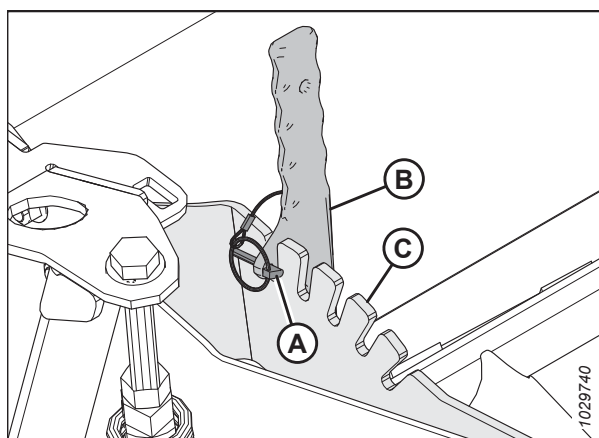

Figure 4.23: Baffle Handle

ASSEMBLING HEADER

4. Turn over deflector (A) and place it on rear baffle (B) and between fixed deflector plate (C) and outer plate (D).
5. Loosely secure deflector (A) in place with retained hardware (E) in three locations. Do **NOT** tighten the hardware. Repeat this step on the opposite side of the header.
6. Adjust the placement of deflector (A) as far inboard as possible so that it contacts fixed deflector plate (C) welded in place on the header. Tighten hardware (E) once the deflector is properly placed. Repeat this step on the opposite side of the header.
7. Ensure that the baffle is adjustable across all working positions without binding.

NOTE:

Some contact is acceptable.

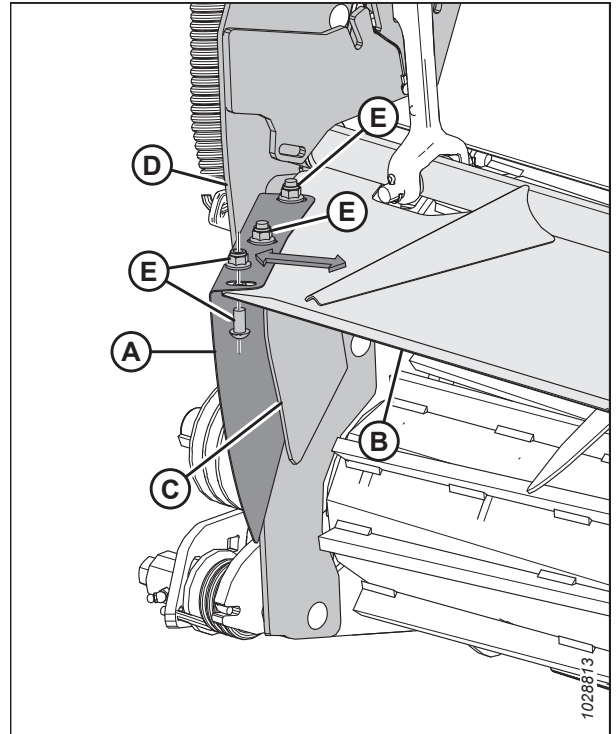

Figure 4.24: Deflector and Rear Baffle

4.4 Assembling and Installing Forming Shield

The forming shield deflectors can be adjusted to form different sizes of windrows. The forming shield is generally designed for use on a rotary disc header with a conditioner. However, the forming shield can also be installed on the grass seed (GSS) version of the header and be used for specific applications, such as harvesting bushy crops (like radishes).

1. Locate and retrieve the hardware included in the bag provided in the forming shield crate.
2. **For headers without the Double Windrow Attachment (DWA) installed, follow these steps:**
 - a. Install shield mount plates (A) on the inside of the windrower legs.
 - b. Install two hex head M12 bolts (B), washers (D), and nuts (C) in the **REAR** holes of the shield mounting plates. This ensures that the forming shield is set at the lowest setting. The lowest setting is used when there is no double windrow attachment (DWA).

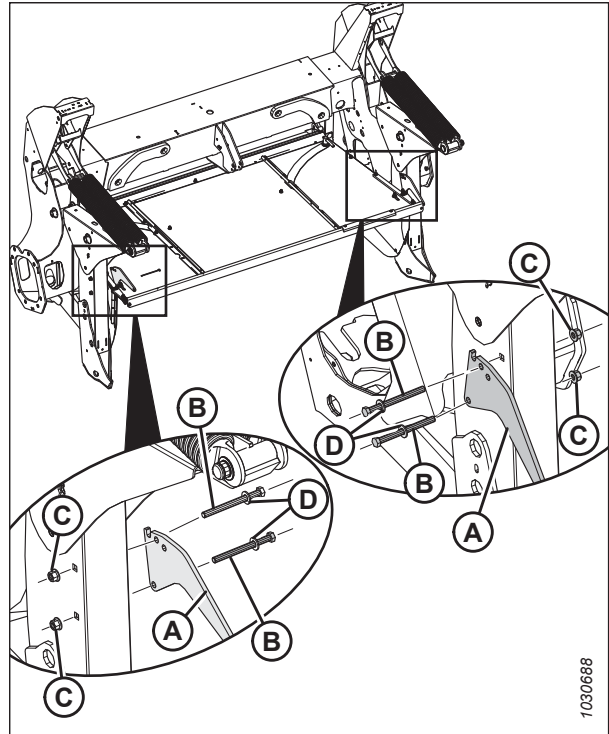

Figure 4.25: Setting Forming Shield for Header without DWA Option

ASSEMBLING HEADER

3. **For headers with the DWA installed, follow these steps:**
 - a. Install shield mount plates (A) on the inside of the windrower legs.
 - b. Install two hex head M12 bolts (B), washers (D), and nuts (C) in the **FRONT** holes of the shield mounting plates. This ensures that the forming shield is set at its highest setting.

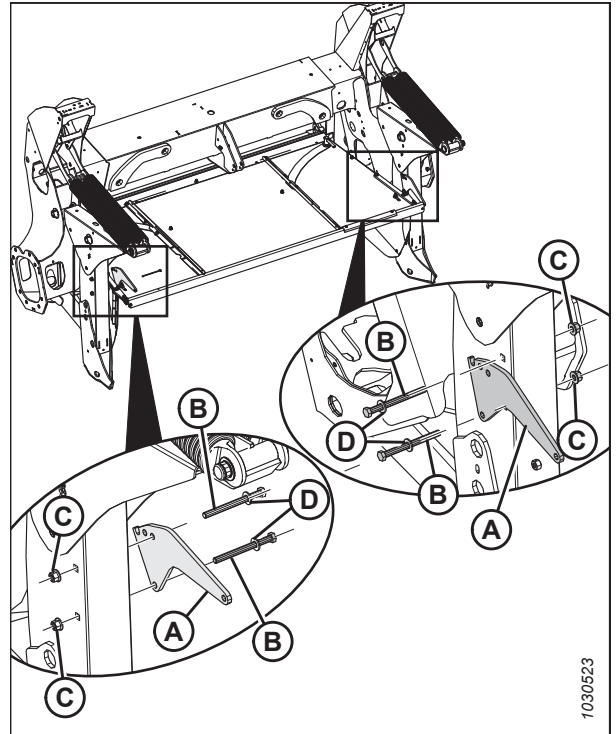

Figure 4.26: Setting Forming Shield for Header with the DWA Option

4. Unpack and remove the packing material from deflectors (A) and (B).
5. Remove right deflector (A) and left deflector (B) from the shipping crate and place them on an even work surface.
6. Remove cover (C) and the parts on top of it from the shipping crate. Place the cover on an even work surface.

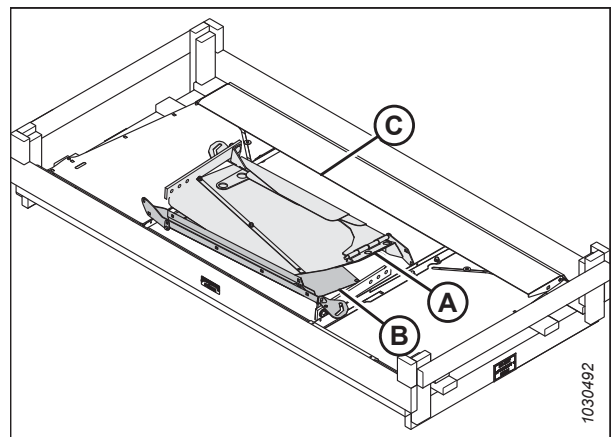

Figure 4.27: Forming Shield in Shipping Crate

ASSEMBLING HEADER

7. Remove right deflector (A) and left deflector (B) from the shipping crate. Retain these deflectors for installation later.
8. Remove hinge rods (C).
9. Remove right bracket (D) and the left bracket.

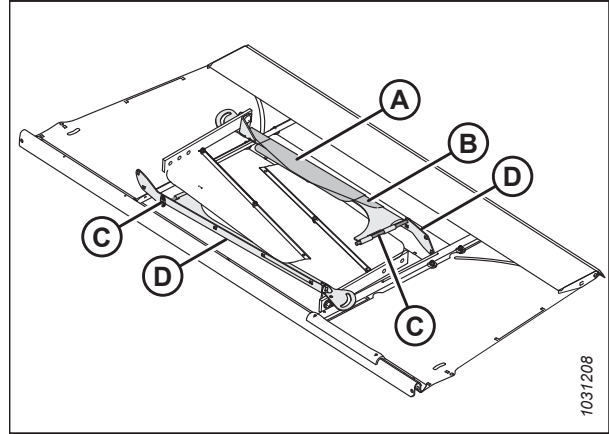

Figure 4.28: Parts Sitting on Cover

10. Remove two bolts (B) from the right end of the cover. Retain the bolts and discard the nuts.
11. Position right bracket (A) on the underside of the cover.
12. Secure right bracket (A) to the cover with three 25 mm long short neck M10 carriage bolts (B) and three nyloc nuts (C).
13. Position support plate (D) on the top of the cover.
14. Secure support plate (D) with two 35 mm-long short neck M10 carriage bolts (E) and two nyloc nuts (F).

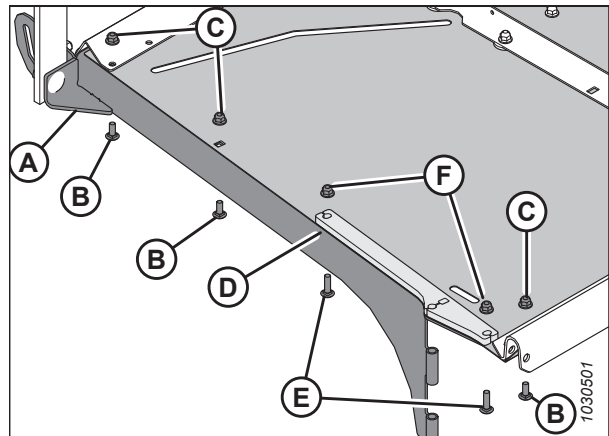

Figure 4.29: Installing Parts on Right End of Cover

15. Use one 25 mm-long short neck M10 carriage bolt (A) and nyloc nut (B) to secure plate (C) on the right bracket to cover angle (D).
16. Repeat Step 10, page 32 to Step 15, page 32 on the left side of the cover.
17. Place the forming shield (that is, the cover assembly) in position under the windrower.

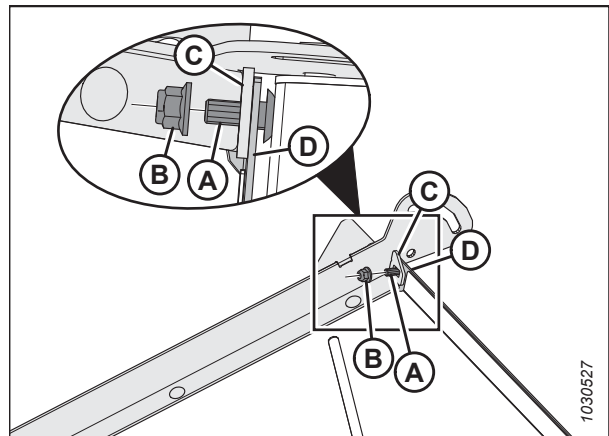

Figure 4.30: Connecting Side Bracket to Cover – Bottom Left Side Shown

ASSEMBLING HEADER

- Using spacer (A), hex head M12 X 130 mm bolt (B), and lock nut (C), attach forming shield (D) to shield mount plate (E) installed on the inside of the windrower legs. Repeat this step on the other side of the windrower and forming shield.

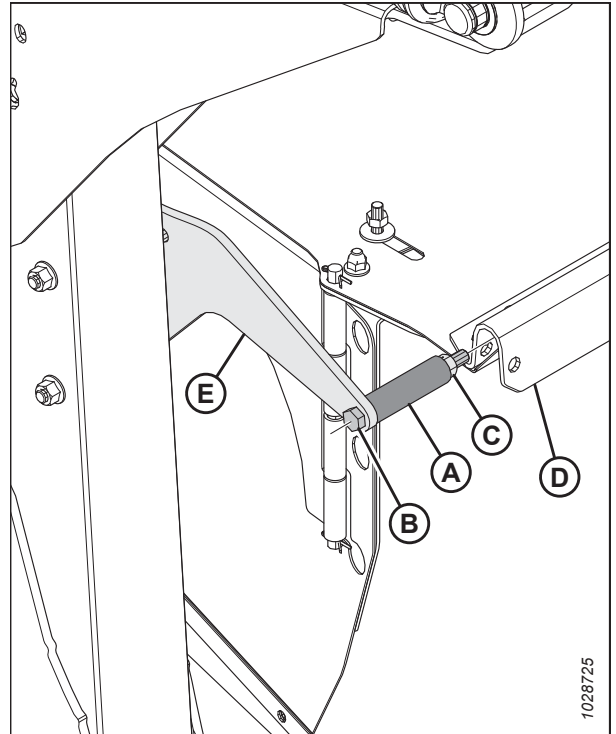

Figure 4.31: Shield Mount Plate and Attaching Hardware – Right Side Shown, Left Side Is Opposite

- Install clevis pin (A) to hold the forming shield in place.

NOTE:

Clevis pin (A) should pass under hex head bolt (B) and the spacer installed in the previous step.

- Secure clevis pin (A) with lynch pin (C). Insert the lynch pin from the outside of the forming shield pointing inward.
- Repeat Step 19, page 33 and Step 20, page 33 on the other side of the forming shield.

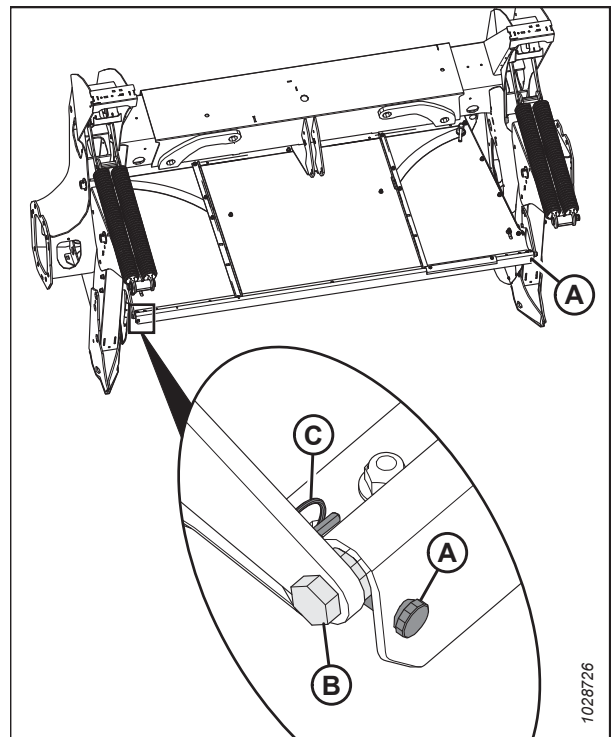

Figure 4.32: Clevis Pin

ASSEMBLING HEADER

22. At the rear of the forming shield, pull rubber strap (A) up towards the windrower frame. Align the first hole in rubber strap (A) with straight pin (B).
23. Secure rubber strap (A) in place with washer (C) and hair pin (D).
24. Repeat Step 22, page 34 to Step 23, page 34 on the left side of the forming shield.

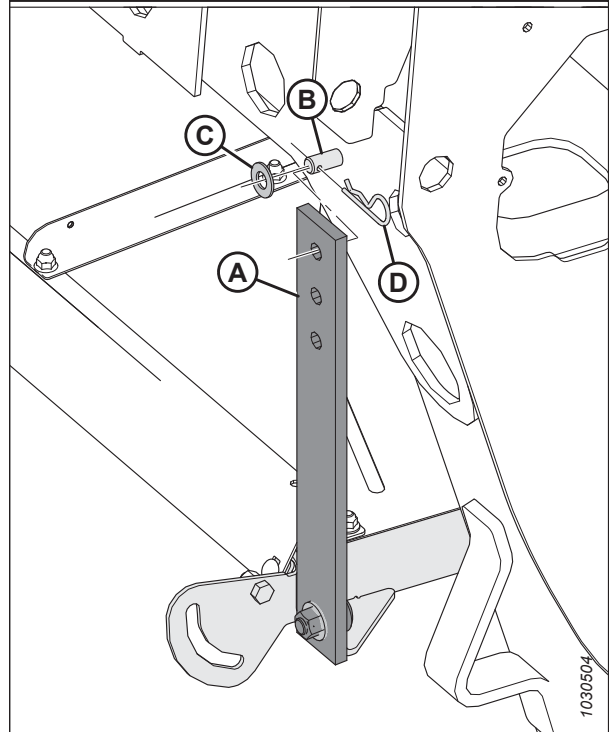

Figure 4.33: Rubber Strap — Right Side of Forming Shield

25. Retrieve baffle (A) from the shipping crate.
26. Secure baffle (A) to right bracket (D) with one 25 mm M12 bolt (B) and nut (C). Snug nut (C) to allow baffle (A) to rotate freely. Repeat this step on the left side of the forming shield.

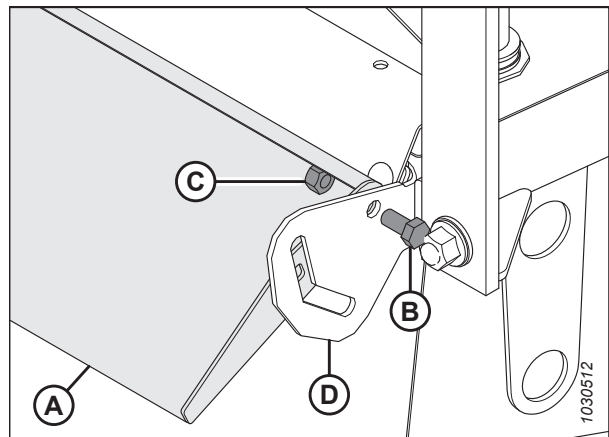

Figure 4.34: Right Bracket and Baffle

ASSEMBLING HEADER

27. Install handle (A) with two flat washers (B) and one rubber washer (C), using one 40 mm-long M12 carriage bolt (D) installed through baffle (F) and right bracket (E). Repeat this step on the other side of the forming shield.

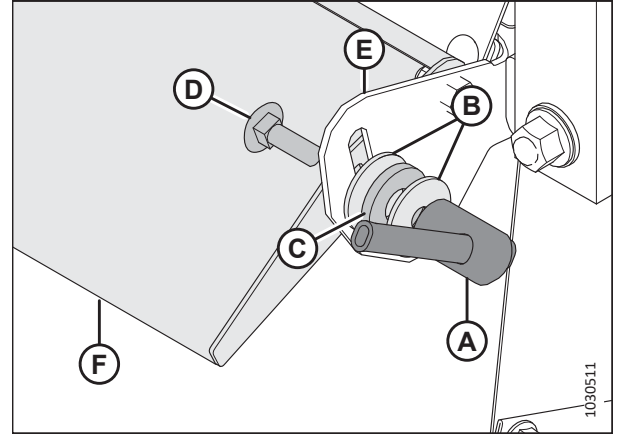

Figure 4.35: Baffle Handle – Right Side Shown, Left Side is Opposite

28. Slide the angled end of deflector adjustment cover (A) under top sheet support angle (B) on top of the forming shield. Repeat this step on the other side of the forming shield.

NOTE:

You may need to loosen hardware (C) securing top sheet support angle (B) to fit deflector adjustment cover (A) underneath. Retighten any loose hardware to hold deflector adjustment covers (A) in place.

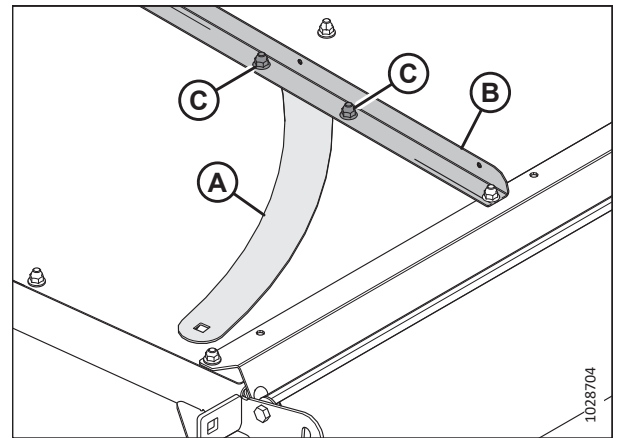

Figure 4.36: Deflector Cover – Left Side Shown, Right Side is Opposite

29. Position right deflector (A) under the right edge of the forming shield, just inboard of the right bracket.

NOTE:

The windrower leg and the shield mount plate have been removed from the illustration so that you can clearly see the deflector and the hardware.

30. Position 40 mm-long M10 bolt (C) as shown. Install hinge plate (B), then secure the bolt and plate with nyloc nut (D).
31. Install one 35 mm-long short neck M10 carriage bolt (E) through the slot near the front of the forming shield and the hole in the deflector. Secure the bolt in place with washer (F) and two jam nuts (G). Tighten the lower nut against the forming shield, but keep it loose enough to rotate freely, then tighten the upper nut against the lower nut.

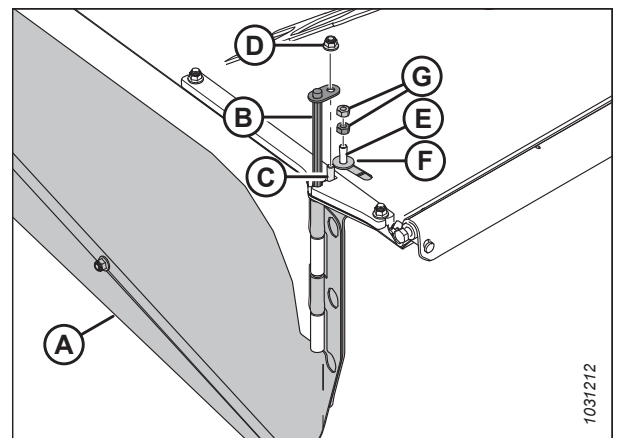

Figure 4.37: Installing Right Deflector

ASSEMBLING HEADER

32. Use one 40 mm-long M12 carriage bolt (A) to secure forming shield cover (F), deflector adjustment cover (B), two flat washers (C), one rubber washer (D), and handle (E) together. Repeat this step on the other side of the forming shield.
33. Repeat Step 29, page 35 to Step 32, page 36 on the other side of the forming shield.

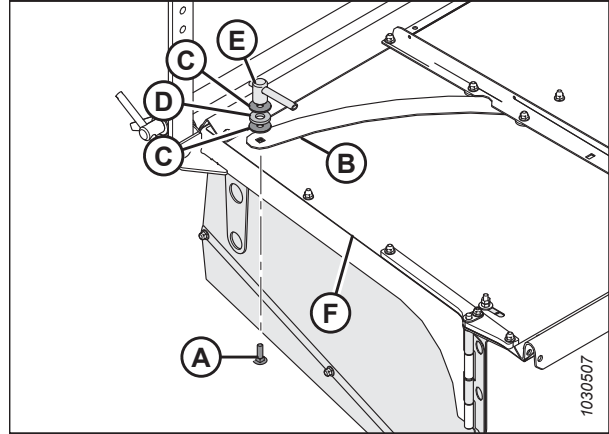

Figure 4.38: Handle on Right Side of Cover

34. Remove bolts and nuts (E) from the front of the forming shield. Retain the bolts and discard the nuts.
35. On the bottom of the forming shield, install right deflector (A) using retained bolts (E), two 25 mm-short neck M10 carriage bolts (C), and nyloc nuts (D). Repeat this step on the left side of the forming shield with left deflector (B).

NOTE:

The narrower deflector end faces the front of the forming shield, while the wider end faces the rear.

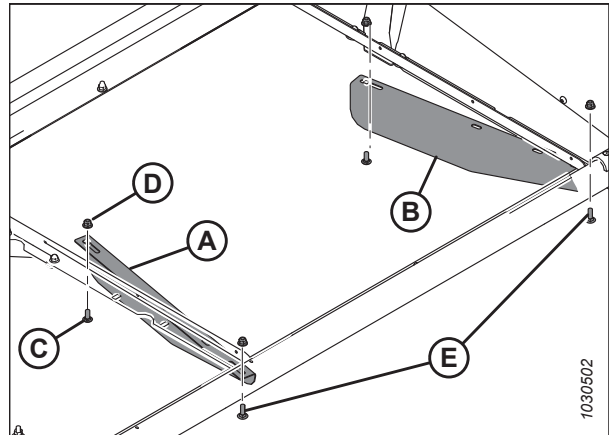

Figure 4.39: Forming Shield

Chapter 5: Attaching Rotary Disc Header to Windrower

The procedure for attaching a rotary disc header to a windrower varies depending on the windrower model and how that windrower is equipped.

Proceed to the procedure that is suitable for your windrower:

- [5.1 Attaching R2 Series Rotary Disc Header to M2 Series Windrower, page 37](#)
- [5.5 Attaching R2 Series Rotary Disc Header to M1 Series Windrower, page 75](#)
- [5.8 Attaching R2 Series Rotary Disc Header to M205 SP Windrower, page 103](#)
- [5.9 Attaching R2 Series Rotary Disc Header to M155 SP Windrower, page 121](#)
- [5.10 Attaching R2 Series Rotary Disc Header to M155E4 SP Windrower, page 135](#)

NOTE:

If you are attaching the R216 Rotary Disc Header to an M2170, M1170, or M155E4 Windrower, the applicable hydraulic drive kit needs to be installed on the header before it can be operated with the windrower. Each hydraulic drive kit includes the required parts and instructions for installation and setup.

- M2170 and M1170 Windrowers require the M1 Hydraulic Drive kit (B6845).
- M155E4 Windrowers require the M155E4 Hydraulic Drive kit (B7310).

5.1 Attaching R2 Series Rotary Disc Header to M2 Series Windrower

The windrower's support feet and center-link will need to be connected to the rotary disc header. The windrower may be equipped with an optional self-aligning hydraulic center-link, which allows control over the vertical position of the center-link from the cab.



DANGER

To prevent bodily injury or death from the unexpected start-up or fall of a raised machine, always stop the engine and remove the key before leaving the operator's seat, and always engage the safety props before going under the machine for any reason.



DANGER

Ensure that all bystanders have cleared the area.

1. Clear all bystanders from the area.
2. Shut down the engine, and remove the key from the ignition.

ATTACHING ROTARY DISC HEADER TO WINDROWER

3. Remove hairpin (A) from clevis pin (B), and remove the pin from header support (C) on both sides of the header.

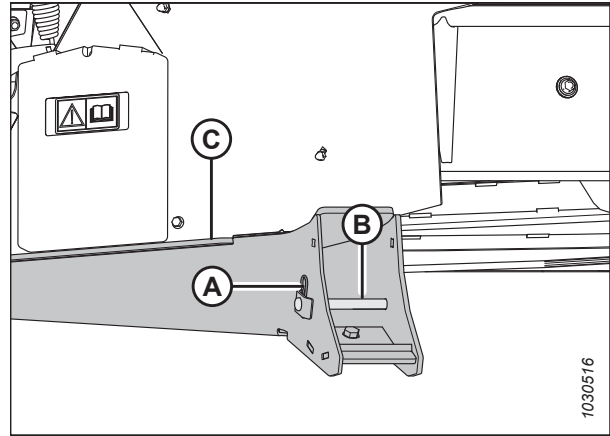

Figure 5.1: Header Support

4. Lift header support (A), and place four 35 x 89 mm (2 x 4 in.) blocks (B) under both of the header supports. Ensure that the boot's bottom edge (C) is parallel with the ground.

NOTE:

Do **NOT** stack blocks (B) crosswise; doing so can make the header unstable when you are attempting to connect the header and the windrower. Stack blocks (B) so that they are aligned with each other.

5. Start the engine.

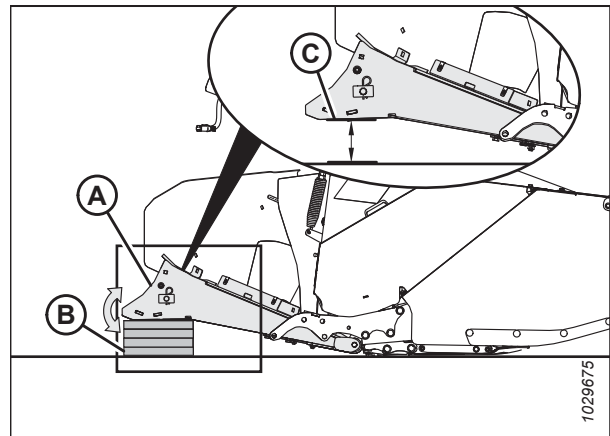

Figure 5.2: Header Support

ATTACHING ROTARY DISC HEADER TO WINDROWER

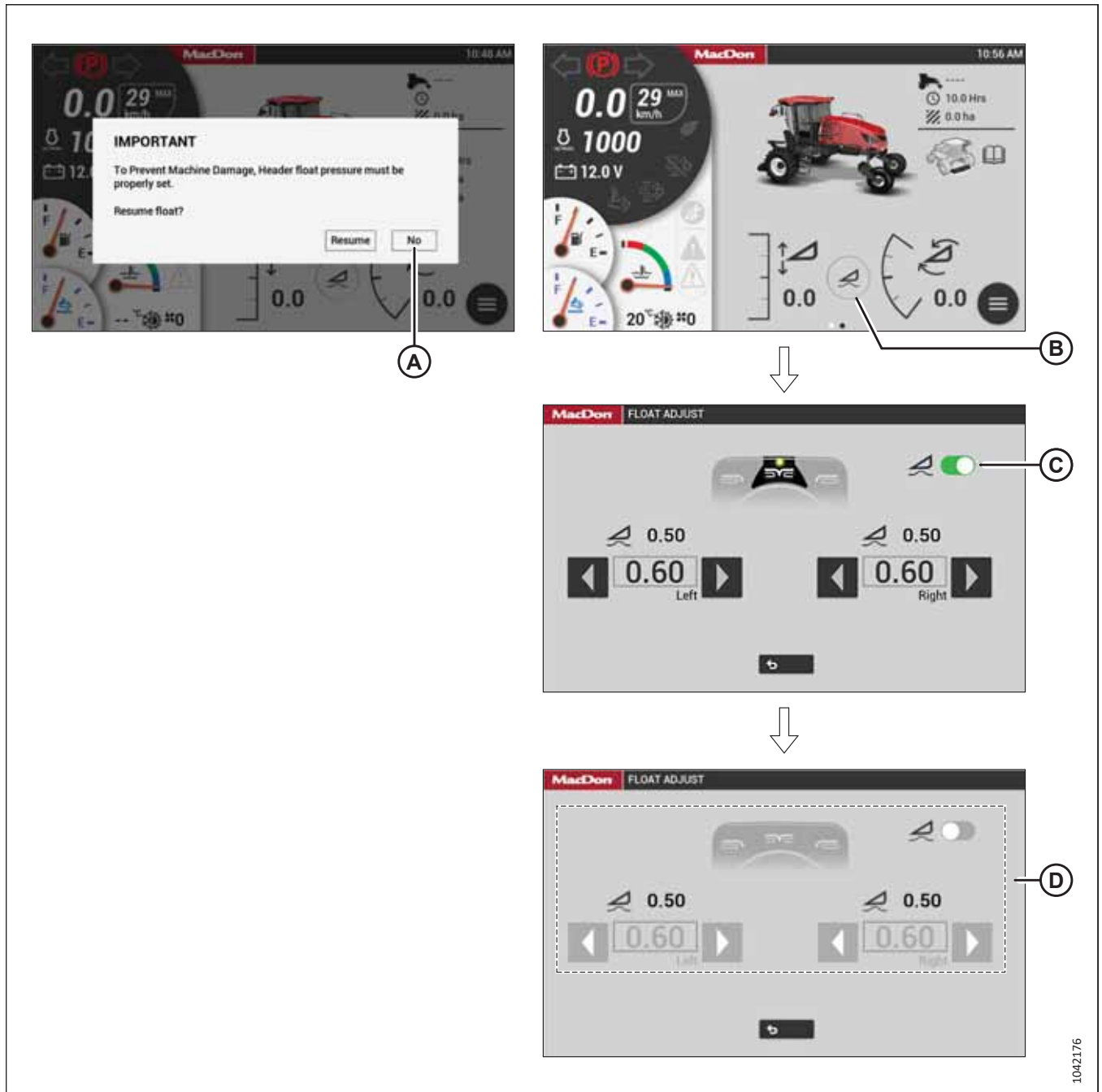

Figure 5.3: Float Removal

6. Remove the float as follows:

- If the HarvestTouch™ Display shows the message “Resume Float?”, then select NO (A).
- If the HarvestTouch™ Display does **NOT** show the message, then select FLOAT ADJUST (B), select switch (C), and confirm the switch and float settings (D) are grayed out.

IMPORTANT:

Removing the float will release the tension in the float springs. This will prevent damage to the header lift linkages when lowering the legs without a header or weight box attached to the windrower.

ATTACHING ROTARY DISC HEADER TO WINDROWER

7. Prepare the center-link as follows:

- **If not equipped with the Center-Link Alignment kit:** Relocate pin (A) in the frame linkage as needed to raise center-link (B) until the hook is above the attachment pin on the header.
- **If equipped with the Center-Link Alignment kit:** Press REEL UP switch (D) on the ground speed lever (GSL) to raise the center-link until the hook is above the attachment pin on the header.

IMPORTANT:

Ensure that the center-link is positioned high enough that it does not contact the header as the windrower approaches the header.

8. Press HEADER DOWN switch (C) on the GSL until the windrower lift linkages are fully lowered.

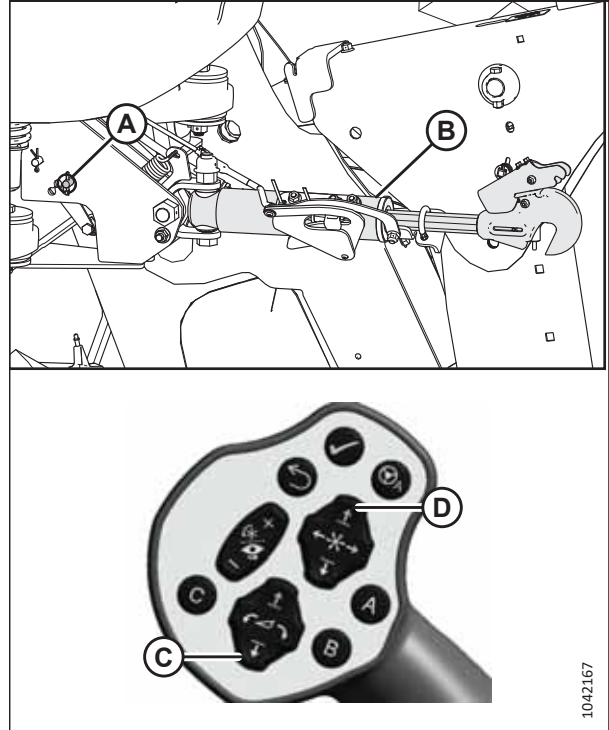

Figure 5.4: Center-Link without Self-Alignment

9. Drive the windrower slowly forward until feet (A) enter supports (B). Continue to drive slowly forward until the feet engage the supports and the header nudges forward.

10. Ensure that feet (A) are properly engaged in supports (B).

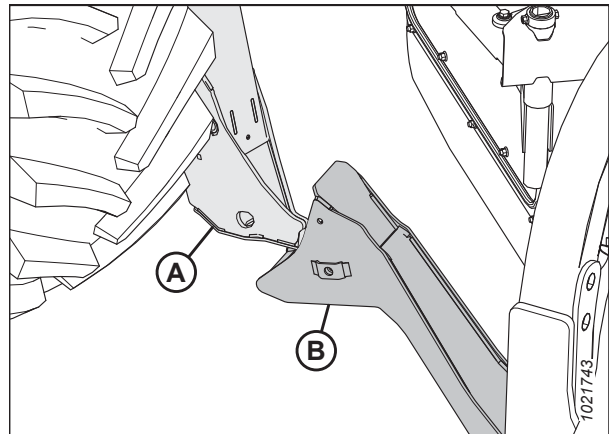

Figure 5.5: Header Support

ATTACHING ROTARY DISC HEADER TO WINDROWER

11. Windrowers equipped with the Center-Link Alignment kit:

- Press HEADER TILT UP (A) or HEADER TILT DOWN (B) switches on the GSL to extend or retract the center-link cylinder until hook (C) is aligned with the header attachment pin.
- Lower the center-link onto the header with REEL DOWN (D) switch on the GSL until the center-link locks into position and hook release (E) is down.

IMPORTANT:

The hook release must be down to enable the self-locking mechanism. If the hook release is open (in the up position), manually push it down after the hook engages the pin.

- Check that the center-link is locked onto the header by pressing REEL UP (F) switch on the GSL.

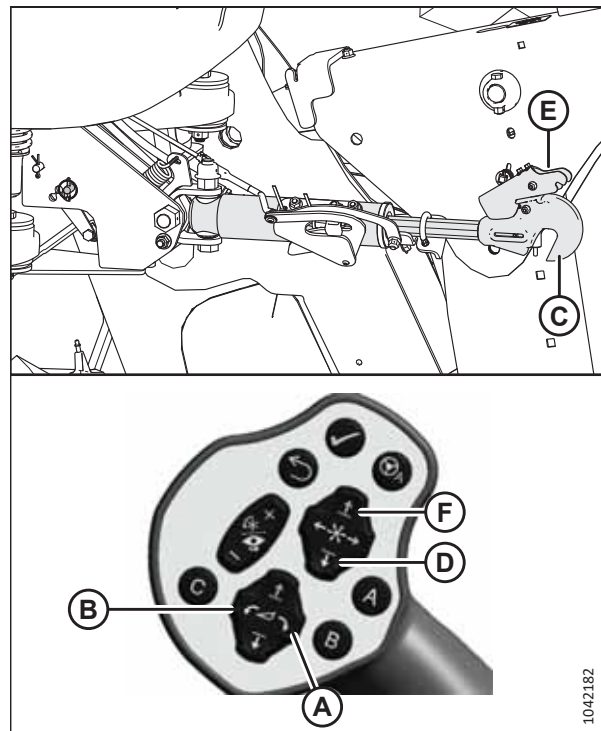

Figure 5.6: Hydraulic Center-Link

12. Windrowers without the Center-Link Alignment kit:

- Press HEADER TILT UP (A) or HEADER TILT DOWN (B) switches on the GSL to extend or retract the center-link cylinder until the hook is aligned with the header attachment pin.
- Shut down the engine, and remove the key from the ignition.
- Push down on rod end (C) of the link cylinder until hook (D) engages and locks onto the header pin.

IMPORTANT:

Hook release (E) must be down to enable the self-locking mechanism. If the hook release is open (in the up position), manually push it down after the hook engages the pin.

- Check that the center-link is locked onto the header by pulling upward on rod end (C) of the cylinder.
- Start the engine.

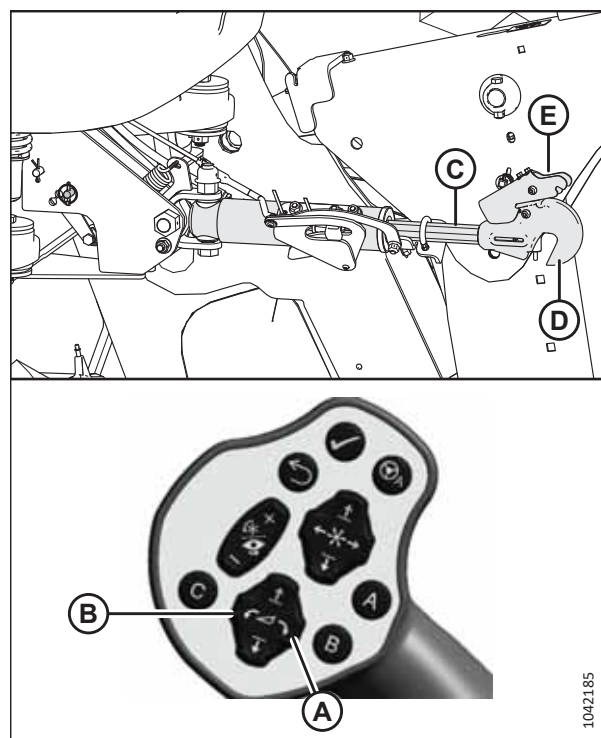

Figure 5.7: Hydraulic Center-Link

ATTACHING ROTARY DISC HEADER TO WINDROWER

13. Press HEADER UP switch (A) to raise the header to its maximum height.

NOTE:

If one end of the header does **NOT** fully rise, rephase the lift cylinders as follows:

- a. Press and hold HEADER UP switch (A) until both cylinders stop moving.
- b. Continue to hold the switch for 3–4 seconds. The cylinders are now phased.

14. Shut down the engine, and remove the key from the ignition.

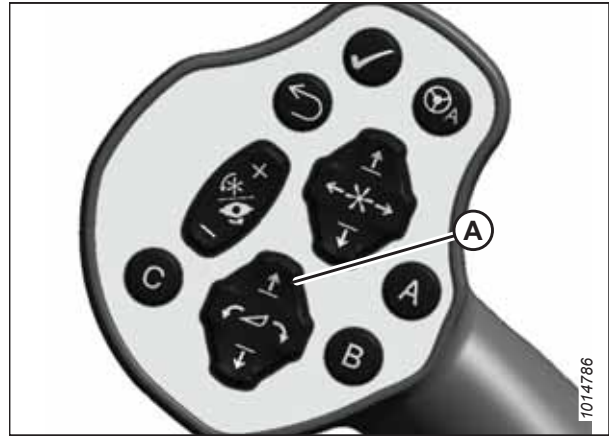

Figure 5.8: GSL

15. Engage the safety props on both lift cylinders as follows:

- a. Pull lever (A) toward you to release it, then rotate it toward the header to lower the safety prop onto the cylinder.
- b. Repeat the previous step for the opposite lift cylinder.

IMPORTANT:

Ensure that the safety props engage over the cylinder piston rods. If the safety prop does **NOT** engage properly, raise the header until the safety prop fits over the rod.

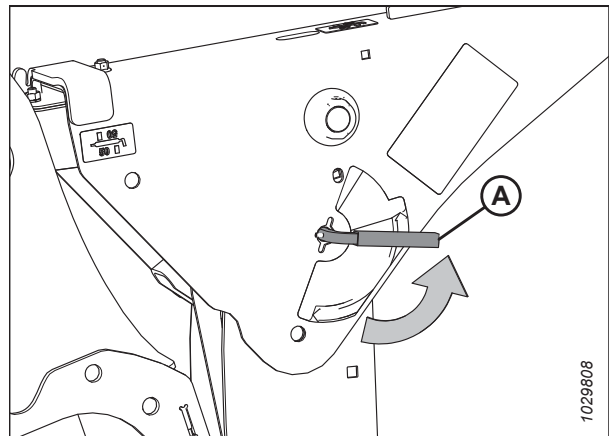

Figure 5.9: Safety Prop Lever

16. Install clevis pin (A) through the support and the windrower lift arm. Secure the clevis pin with hairpin (B). Repeat this step on the opposite side of the header.

IMPORTANT:

Ensure that clevis pin (A) is fully inserted, and that the hairpin is installed behind the bracket as shown.

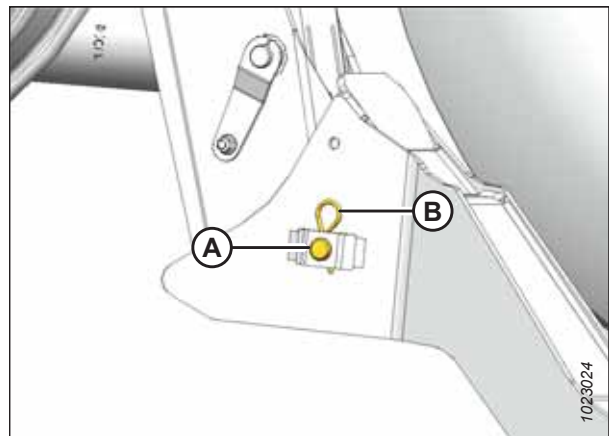

Figure 5.10: Header Support

ATTACHING ROTARY DISC HEADER TO WINDROWER

17. Disengage the safety props on both lift cylinders as follows:
 - a. Turn lever (A) away from the header to raise the safety prop until the lever locks into the vertical position.
 - b. Repeat the previous step for the opposite cylinder.

NOTE:

If the safety prop will **NOT** disengage, raise the header to release the prop.

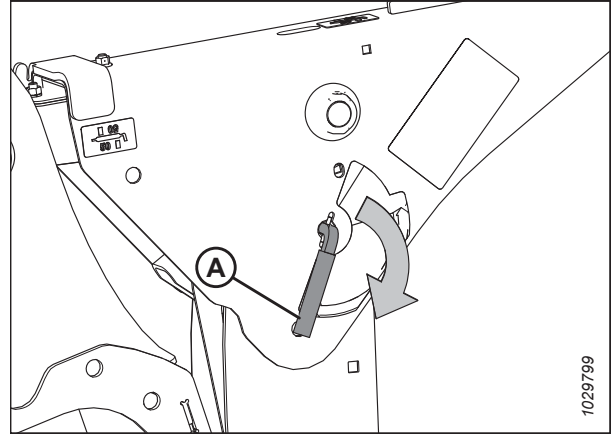

Figure 5.11: Safety Prop Lever

18. Start the engine, and press HEADER DOWN switch (A) on the GSL to fully lower the header.



Figure 5.12: GSL

19. Select FLOAT ADJUST (A).

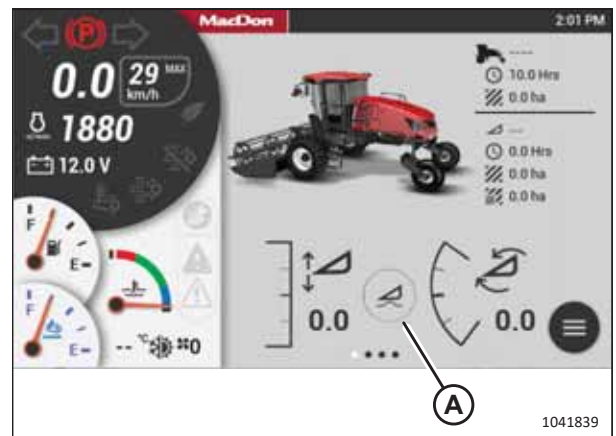

Figure 5.13: HarvestTouch™ Display

Figure 5.14: Float Adjustment

20. Select switch (A), so that it turns green, to activate the float.
21. If not already set up, set the float as follows:
 - a. The float preset, which is selected using the operator's console, is displayed at location (B). Confirm if the desired preset is selected.
 - b. Select arrows (C) to set the target float for the left side of the header. Value (E) is the actual amount of float (measured by the left float sensor).
 - c. Select arrows (D) to set the target float for the right side of the header. Value (F) is the actual amount of float (measured by the left float sensor).

NOTE:

Adjusting the float by increments of 1.0 (out of 10) changes the header weight at the cutterbar by approximately 91 kg (200 lb.). Adjust the float in increments of 0.05 to fine-tune the header's performance.

NOTE:

Symbols (G) and (H) mean the left and right float sensors are not working. You can still manually set the float, but you should first check if the sensors were disabled through the HarvestTouch™ Display (refer to MENU > SETUP > HEADER > SENSORS), or if another problem is causing the sensors to fail.

22. Shut down the engine, and remove the key from the ignition.
23. Check the float as follows:
 - a. Grasp one end of the header and lift it. The lifting force used should be 426–471 N (95–105 lbf).
 - b. Repeat this step on the other side of the header.
24. Proceed as follows:
 - If you are attaching the header to an M2170 Windrower: [5.1.1 Connecting R2 Series Rotary Disc Header Hydraulic and Electrical Components – M2170 Windrower, page 44](#)
 - If you are attaching the header to an M2260 Windrower: [5.1.2 Connecting R2 Series Rotary Disc Header Hydraulic and Electrical Systems – M2260 Windrower, page 50](#)

5.1.1 Connecting R2 Series Rotary Disc Header Hydraulic and Electrical Components – M2170 Windrower

Connecting the header hydraulic and electrical systems to the windrower involves attaching the header's knife drive, pressure, return, case drain, and electrical connectors to the windrower's receptacles.

DANGER

To prevent bodily injury or death from the unexpected start-up of the machine, always stop the engine and remove the key from the ignition before making adjustments to the machine.

CAUTION

Do NOT stand on an unlocked platform. It is unstable and may cause you to fall.

IMPORTANT:

To prevent contamination of the hydraulic system, use a clean rag to remove dirt and moisture from all (fixed and movable) hydraulic couplers.

1. Shut down the engine, and remove the key from the ignition.

ATTACHING ROTARY DISC HEADER TO WINDROWER

2. Approach platform (A) on the left side of the windrower. Ensure that the cab door is closed.
3. Push latch (B) and pull platform (A) toward the walking beam until it stops and the latch engages.

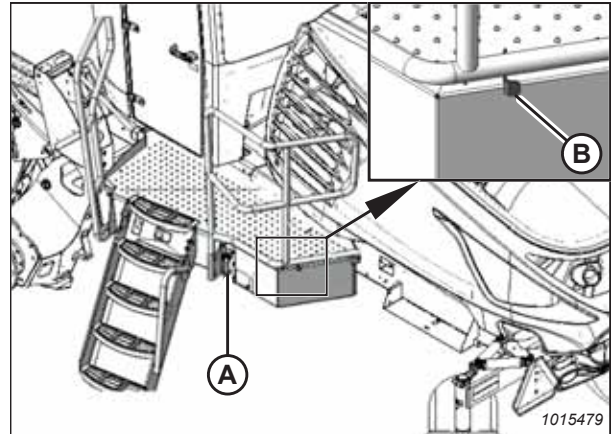

Figure 5.15: Left Platform

4. Retrieve hydraulic hoses (A) from the header and route the hose bundle under the windrower frame.

NOTE:

Adding anti-seize compound to the hose holder pin will make future removal easier.

5. Insert pin (B) into hole (C) in the windrower frame.

IMPORTANT:

Route the hydraulic hoses as straight as possible, avoiding wear points that could damage the hoses. To prevent abrasion damage, the hoses should have enough slack to pass by the multicoupler bracket without contacting it. To adjust the slack in the hoses, loosen the clamps below pin (B), adjust the hoses, then retighten the hose holder.

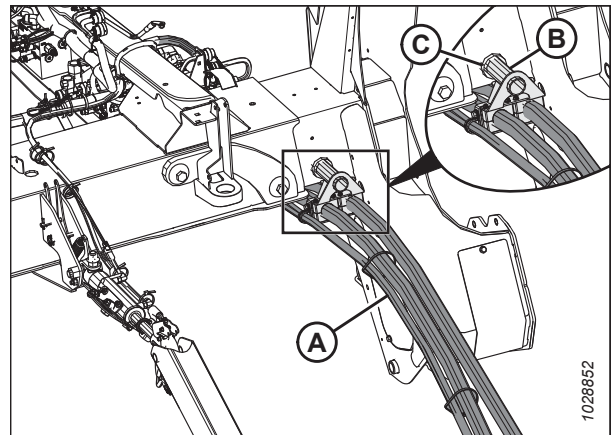

Figure 5.16: Hose Support Attachment

ATTACHING ROTARY DISC HEADER TO WINDROWER

6. If using hard-plumbed fittings (A), proceed to Step 7, page 46. If using quick couplers (B), proceed to Step 8, page 47.

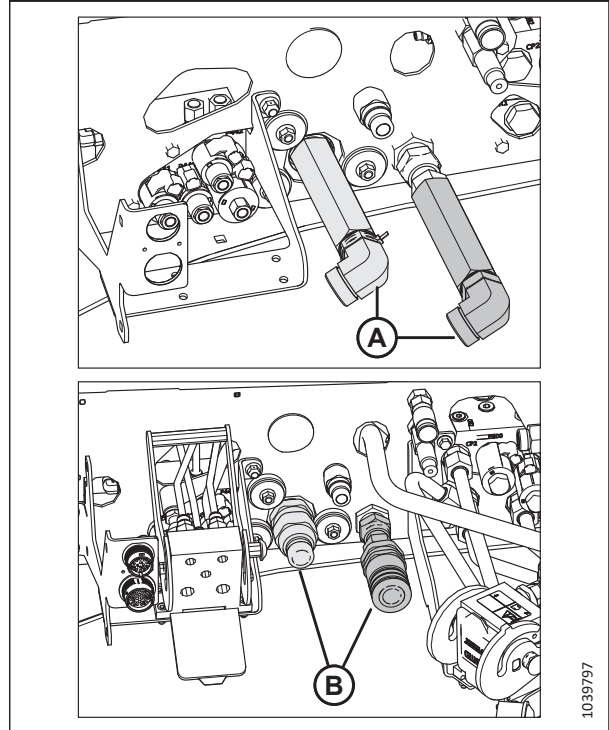

Figure 5.17: Hard-Plumbed Fittings Compared to Quick Couplers

7. To connect hard-plumbed fittings, connect the hydraulic hoses to the windrower as follows:
- Connect disc pressure hose (A) (fitted with red cable tie [B]) to hard plumb fitting (C) (fitted with a red cable tie) and torque the connection to 215 Nm (159 lbf-ft).
 - Connect disc return hose (D) to hard plumb fitting (E) and torque the connection to 215 Nm (159 lbf-ft).
 - Connect case drain hose (F) to fitting (G).
 - Proceed to Step 10, page 48.

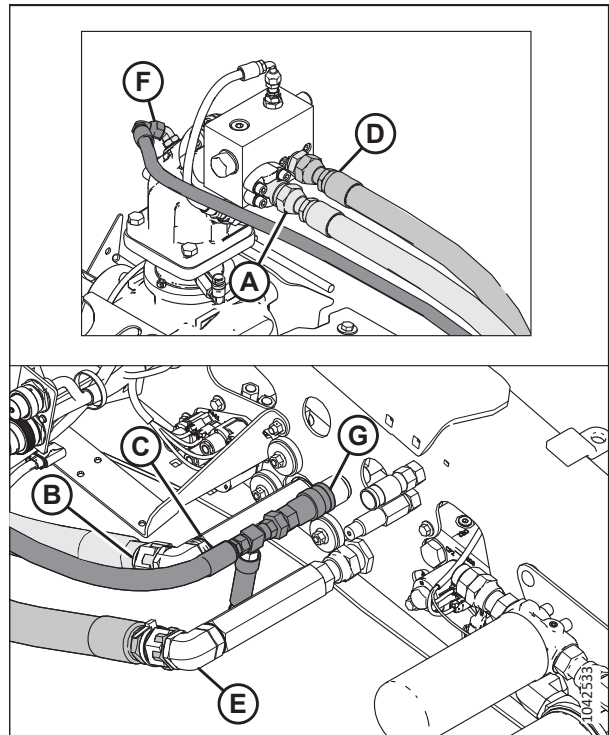

Figure 5.18: Hard-Plumbed Fittings

ATTACHING ROTARY DISC HEADER TO WINDROWER

8. **Quick couplers:** If switching from an auger/drapper header to a rotary header, disconnect hose (A) from knife pressure receptacle (C) on the frame, and move it to storage location (B).

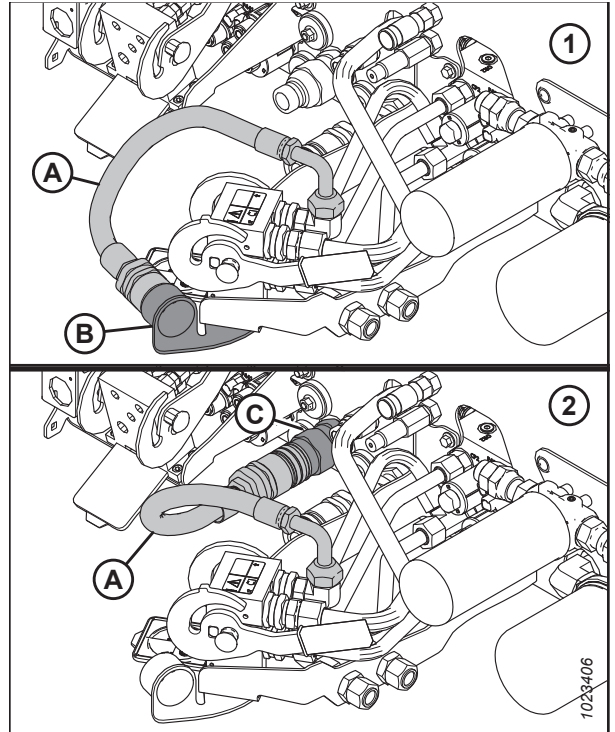

Figure 5.19: Knife Pressure Hose Positions

- 1 - Knife Pressure Hose in Storage Position – Rotary Configuration
2 - Hose to Knife Pressure Receptacle – Auger/Draper Configuration

9. **To connect quick couplers,** connect the hydraulic hoses to a windrower with quick coupler fittings as follows:
- Connect disc pressure hose (A) to coupler (B). Torque the connection to 216 Nm (159 lbf-ft).
 - Connect disc return hose (C) to coupler (D). Torque the connection to 216 Nm (159 lbf-ft).
 - Connect case drain hose (E) to fitting (F), with the relief valve pointing towards the ground.

NOTE:

If necessary, loosen fitting (F) and retighten it to ensure that the relief valve is pointing straight down.

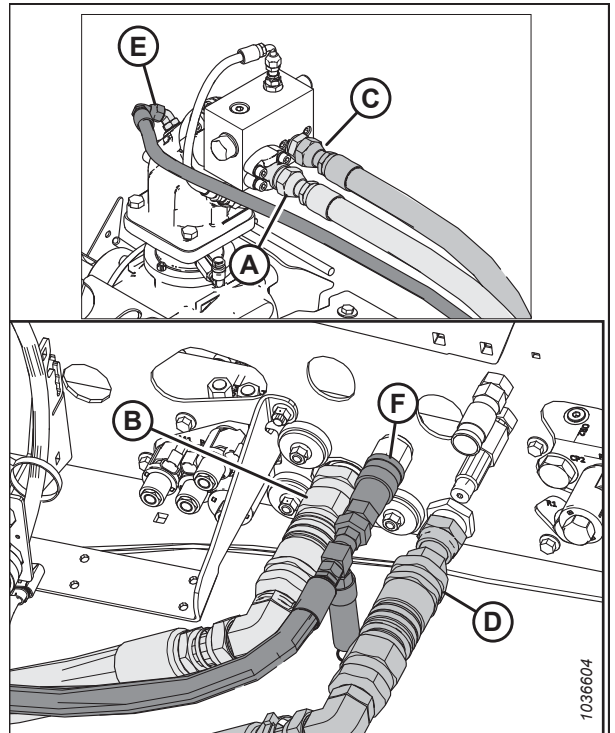

Figure 5.20: Quick Couplers

ATTACHING ROTARY DISC HEADER TO WINDROWER

10. Free electrical harness (A) from adjustable strap (B).

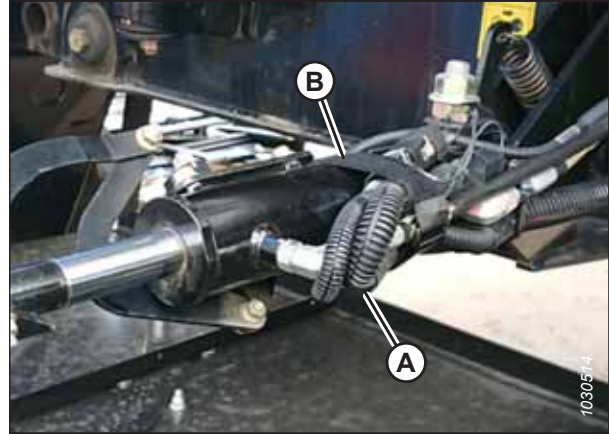

Figure 5.21: Electrical Harness Secured to Center-Link

11. Connect main header harness (A) to adapter harness (B).
12. **Headers equipped with electric baffle control kit:** connect electric baffle control harness (C) to adapter harness (D).

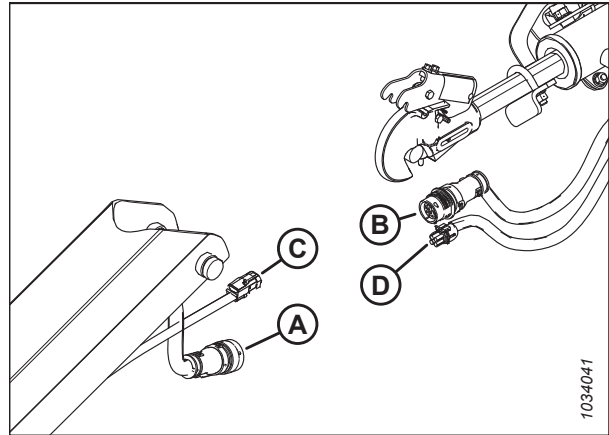

Figure 5.22: Electrical Harness Connection at Center-Link

13. Push latch (A) to unlock platform (B).

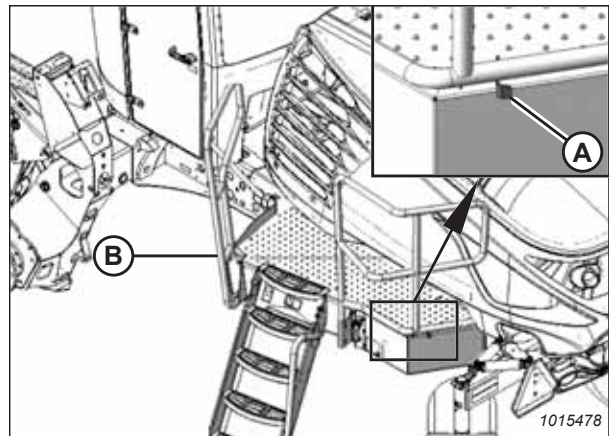

Figure 5.23: Left Platform

ATTACHING ROTARY DISC HEADER TO WINDROWER

14. Pull platform (A) toward the cab until it stops and the latch is engaged.

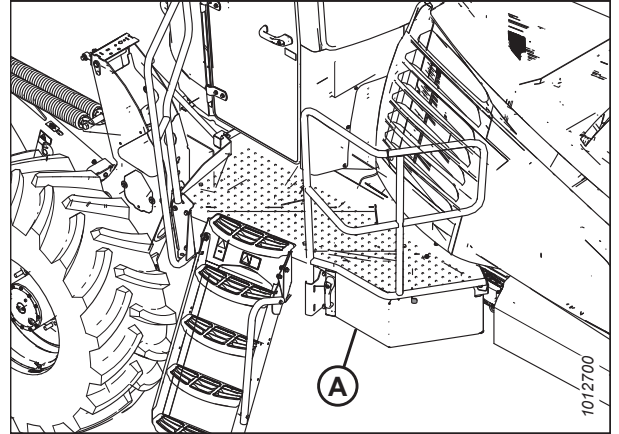

Figure 5.24: Left Platform

⚠ DANGER

Ensure that all bystanders have cleared the area.

15. Clear all bystanders from the area.
16. Start the engine.
17. Extend center-link (A) fully. Ensure that there is some slack in harness (B).
18. Retract center-link (A) fully. Ensure that there is not an excessive amount of harness (B) hanging down.
19. Shut down the engine, and remove the key from the ignition.
20. Adjust harness (B) as needed.
21. Tighten all the cables along the harness.
22. If this is the first time the header is connected to the windrower, calibrate the header. For instructions, refer to [5.2 Calibrating M2 Series Windrower and Header on HarvestTouch™ Display, page 66](#).

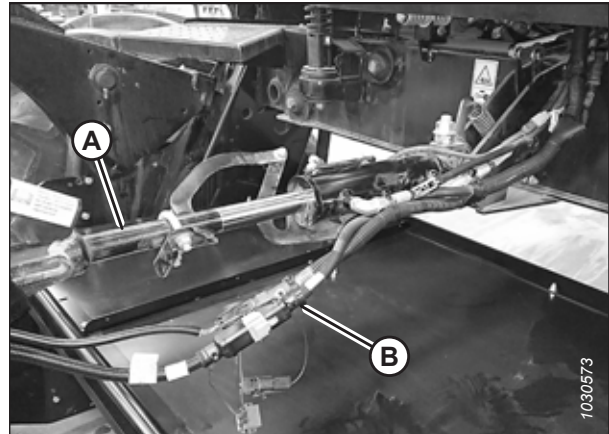

Figure 5.25: Electrical Connection

5.1.2 Connecting R2 Series Rotary Disc Header Hydraulic and Electrical Systems – M2260 Windrower

The header's hydraulic and electrical multicoupler will need to be connected to the windrower.

Proceed to the relevant procedure:

Auger/rotary disc/drapper-ready configuration (A): refer to [Auger/Rotary Disc/Draper-Ready Configuration – Quick Coupler Connections, page 51](#) for instructions.

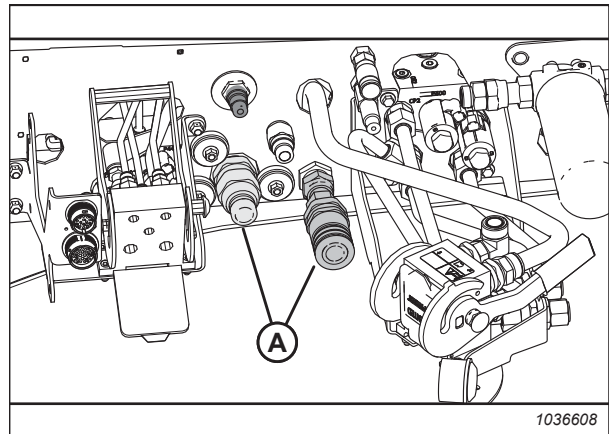

Figure 5.26: Header Hydraulics Configurations – Auger/Rotary Disc/Draper-Ready

ATTACHING ROTARY DISC HEADER TO WINDROWER

Rotary disc-only hard-plumbed configuration (A): refer to *Rotary Disc-Only Configuration – Hard-Plumbed Connections*, page 56 for instructions.

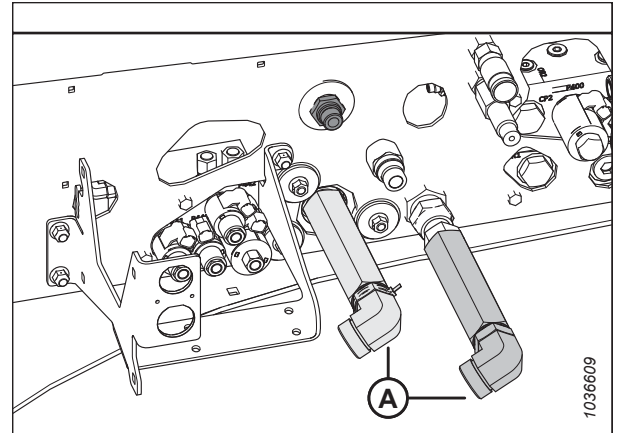

Figure 5.27: Header Hydraulics Configuration – Rotary Disc-Ready with Hard-Plumbed Connections

Rotary disc-ready configuration with quick couplers (A): refer to *Rotary Disc-Only Configuration – Quick Coupler Connections*, page 61 for instructions.

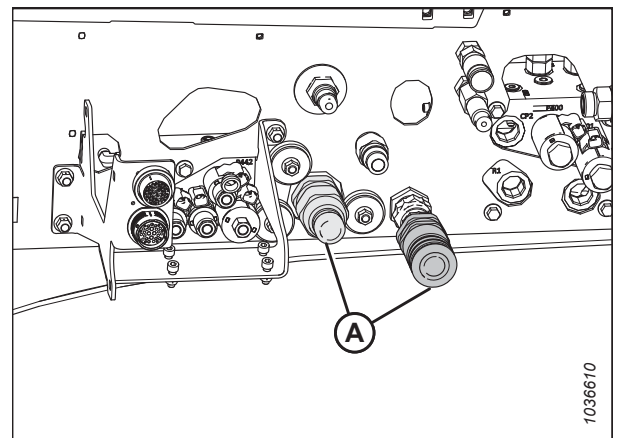

Figure 5.28: Header Hydraulics Configuration – Rotary Disc-Ready with Quick Couplers

Auger/Rotary Disc/Draper-Ready Configuration – Quick Coupler Connections

Windrowers with the auger/rotary disc/draper-ready configuration are equipped with the hydraulic connections needed to pair with an auger, rotary disc, or draper header.

DANGER

To prevent bodily injury or death from the unexpected start-up of the machine, always stop the engine and remove the key from the ignition before making adjustments to the machine.

CAUTION

Do NOT stand on an unlocked platform. It is unstable and may cause you to fall.

IMPORTANT:

To prevent contamination of the hydraulic system, use a clean rag to remove dirt and moisture from all (fixed and movable) hydraulic couplers.

1. Shut down the engine, and remove the key from the ignition.

ATTACHING ROTARY DISC HEADER TO WINDROWER

2. Approach platform (A) on the left side of the windrower. Ensure that the cab door is closed.
3. Push latch (B) and pull platform (A) toward the walking beam until it stops and the latch engages.

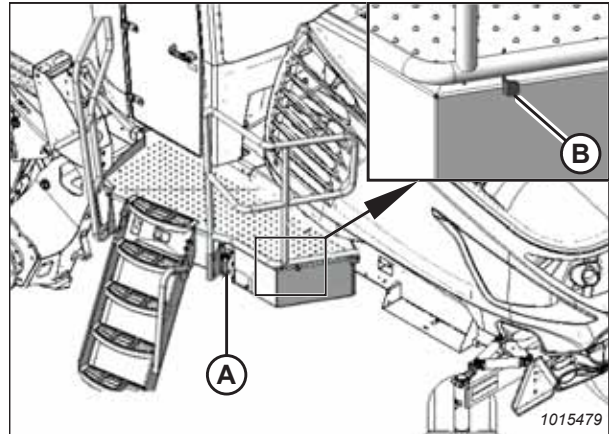

Figure 5.29: Left Platform

4. Retrieve hydraulic hoses (A) from the header and route the hose bundle under the windrower frame.

NOTE:

Adding anti-seize compound to the hose holder pin will make future removal easier.

5. Insert pin (B) into hole (C) in the windrower frame.

IMPORTANT:

Route the hydraulic hoses as straight as possible, avoiding wear points that could damage the hoses. To prevent abrasion damage, the hoses should have enough slack to pass by the multicoupler bracket without contacting it. To adjust the slack in the hoses, loosen the clamps below pin (B), adjust the hoses, then retighten the hose holder.

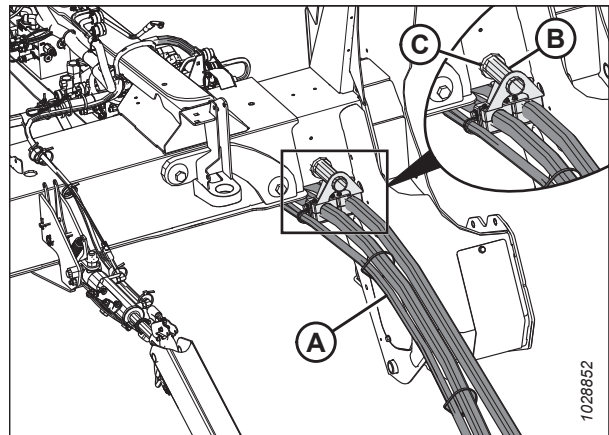

Figure 5.30: Hose Support Attachment

6. Ensure that hose (A) is disconnected from windrower receptacle (B) and placed in storage cup (C) on the multicoupler.

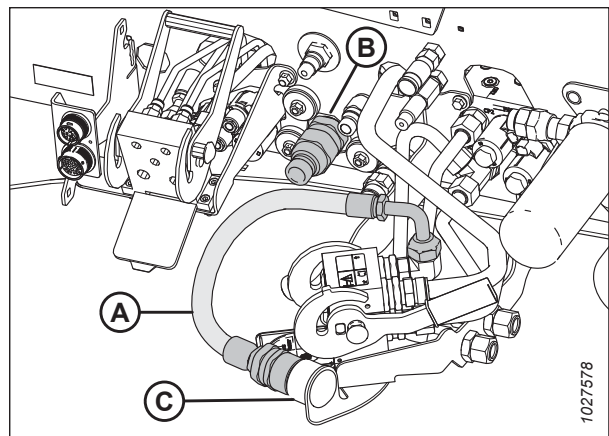

Figure 5.31: Couplers – Auger/Rotary Disc/Draper-Ready Configuration

ATTACHING ROTARY DISC HEADER TO WINDROWER

7. Connect the hydraulic fittings to the hydraulic hoses as follows:

NOTE:

The two quick couplers and two elbow fittings are supplied in the Quick Coupler kit (B6277).

- a. Attach 90° elbow fitting (A) and 1 in. female coupler fitting (B) to disc pressure hose (C).
- b. Attach 90° elbow fitting (A) and 1 in. male coupler fitting (D) to disc return hose (E).

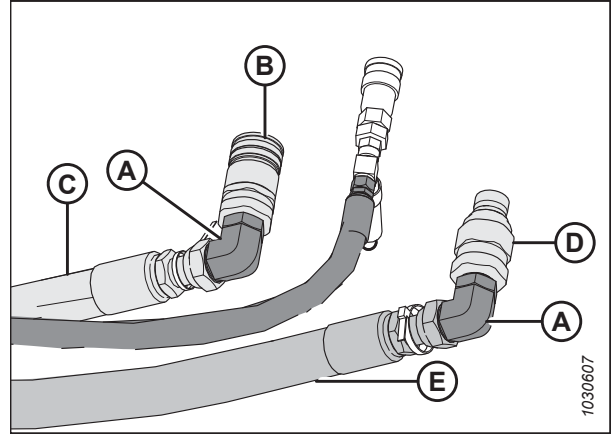

Figure 5.32: Header Hydraulic Fittings

8. Connect the hydraulic hoses to the windrower as follows:

- a. Connect disc pressure hose (A) to coupler (B).
- b. Connect disc return hose (C) to coupler (D).
- c. Connect case drain hose (E) to fitting (F) so that the relief valve points toward the ground.

NOTE:

Loosen and tighten fitting (F) as needed to ensure that the relief valve is pointing down.

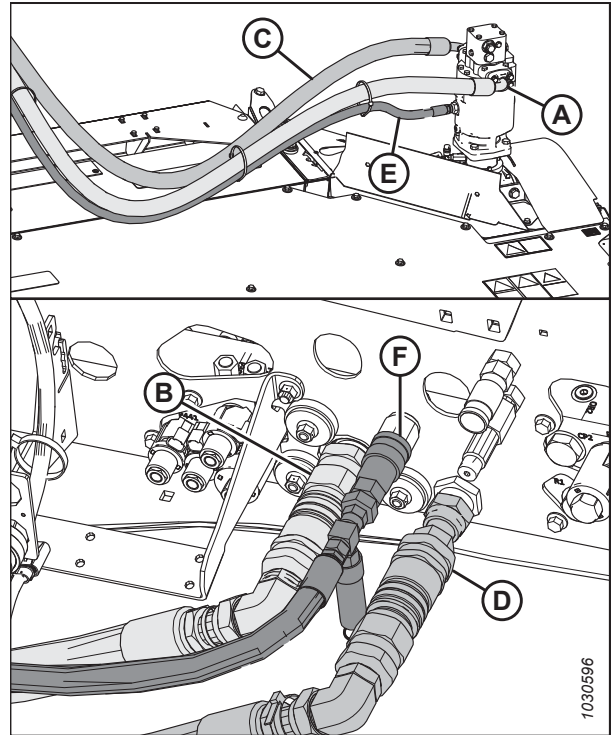

Figure 5.33: Hydraulics and Electrical – Auger/Rotary Disc/Draper-Ready Configuration

ATTACHING ROTARY DISC HEADER TO WINDROWER

9. **For grass seed headers (GSS)**, connect the additional four hoses supplied with the grass seed version of the header as follows:

- a. Connect the hose with the green cable tie with female quick coupler (A) to coupler (B) on the windrower frame.
- b. Connect the hose with the yellow cable tie with male quick coupler (C) to coupler (D) on the windrower frame.
- c. Remove the cap (not shown) from inboard bulkhead fitting (E). Connect hose (F) (red cable tie) to inboard bulkhead fitting (E).

NOTE:

The other end of hose (F) connects to the grass seed module's drum on the left side of the header.

- d. Remove the cap (not shown) from outboard bulkhead fitting (G). Connect hose (H) (blue cable tie) to outboard bulkhead fitting (G).

NOTE:

The other end of hose (H) connects to the grass seed module's drum on the right side of the header.

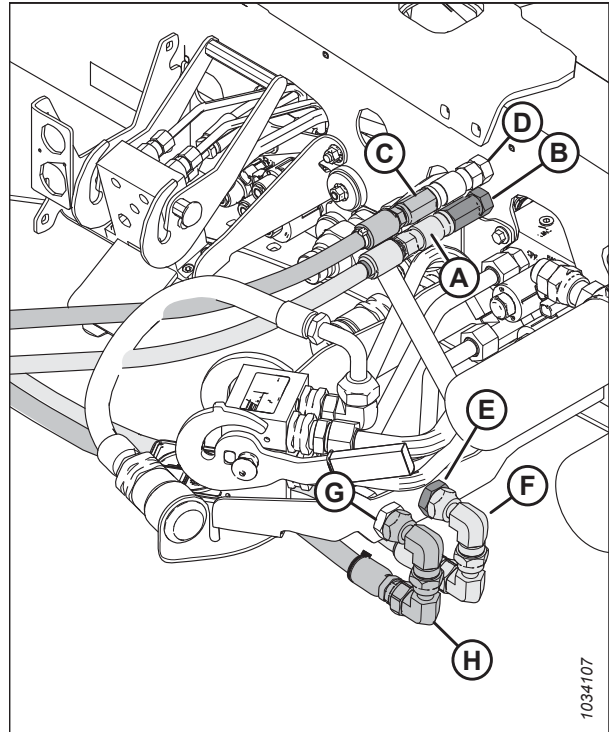

Figure 5.34: Grass Seed Hydraulic Connections – Auger/Rotary Disc/Draper-Ready Configuration

10. Free electrical harness (A) from adjustable strap (B).

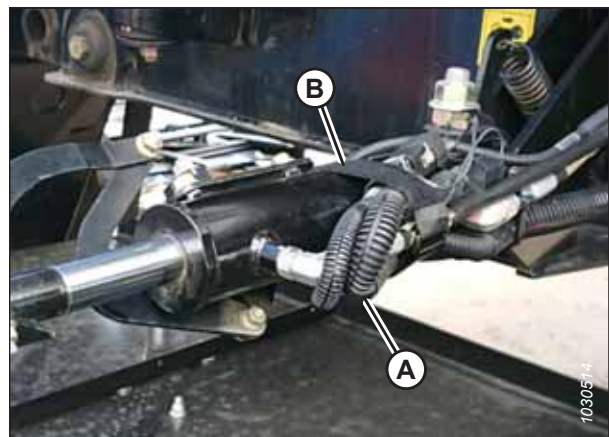

Figure 5.35: Electrical Harness Secured to Center-Link

ATTACHING ROTARY DISC HEADER TO WINDROWER

11. Connect main header harness (A) to adapter harness (B).
12. **Headers equipped with electric baffle control kit:** connect electric baffle control harness (C) to adapter harness (D).
13. **Grass seed headers (GSS):** connect actuator harness (C) to adapter harness (D).

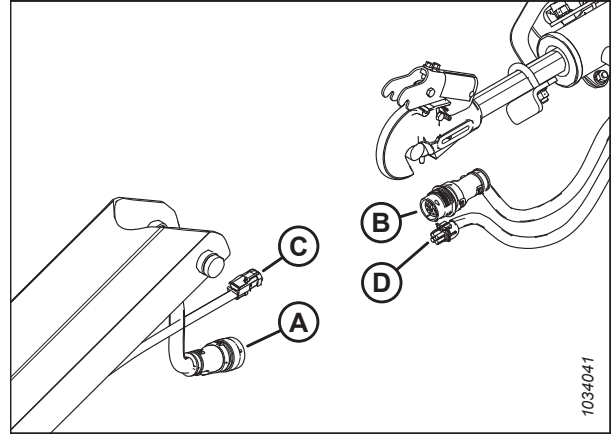

Figure 5.36: Electrical Harness Connection at Center-Link

14. Push latch (A) to unlock platform (B).

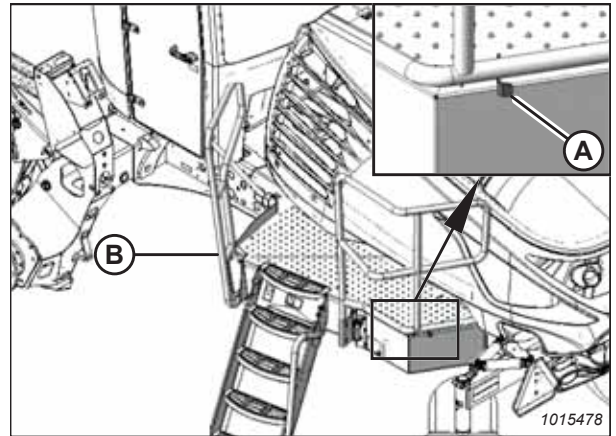

Figure 5.37: Left Platform

15. Pull platform (A) toward the cab until it stops and the latch is engaged.

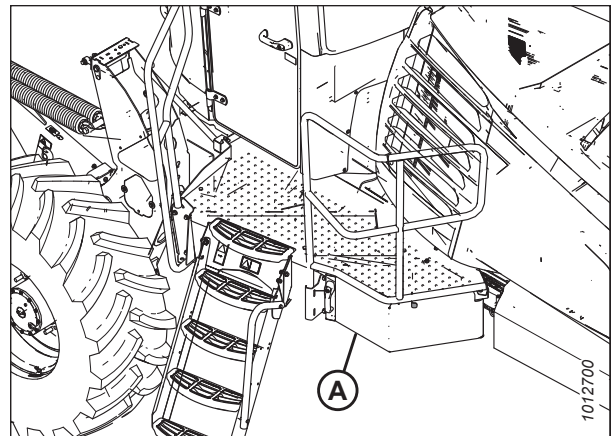

Figure 5.38: Left Platform

ATTACHING ROTARY DISC HEADER TO WINDROWER

DANGER

Ensure that all bystanders have cleared the area.

16. Clear all bystanders from the area.
17. Start the engine.
18. Extend center-link (A) fully. Ensure that there is some slack in harness (B).
19. Retract center-link (A) fully. Ensure that there is not an excessive amount of harness (B) hanging down.
20. Shut down the engine, and remove the key from the ignition.
21. Adjust harness (B) as needed.
22. Tighten all the cables along the harness.
23. If this is the first time the header is connected to the windrower, calibrate the header. For instructions, refer to [5.2 Calibrating M2 Series Windrower and Header on HarvestTouch™ Display](#), page 66.

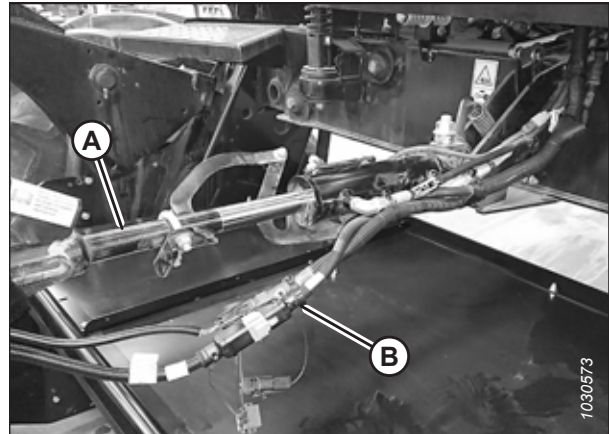

Figure 5.39: Electrical Connection

Rotary Disc-Only Configuration – Hard-Plumbed Connections

The rotary disc-only configuration allows the windrower to operate with compatible rotary disc headers. The hydraulic connections must be torqued correctly when using hard-plumbed fittings.

DANGER

To prevent bodily injury or death from the unexpected start-up of the machine, always stop the engine and remove the key from the ignition before making adjustments to the machine.

CAUTION

Do NOT stand on an unlocked platform. It is unstable and may cause you to fall.

IMPORTANT:

To prevent contamination of the hydraulic system, use a clean rag to remove dirt and moisture from all (fixed and movable) hydraulic couplers.

1. Shut down the engine, and remove the key from the ignition.

ATTACHING ROTARY DISC HEADER TO WINDROWER

2. Approach platform (A) on the left side of the windrower. Ensure that the cab door is closed.
3. Push latch (B) and pull platform (A) toward the walking beam until it stops and the latch engages.

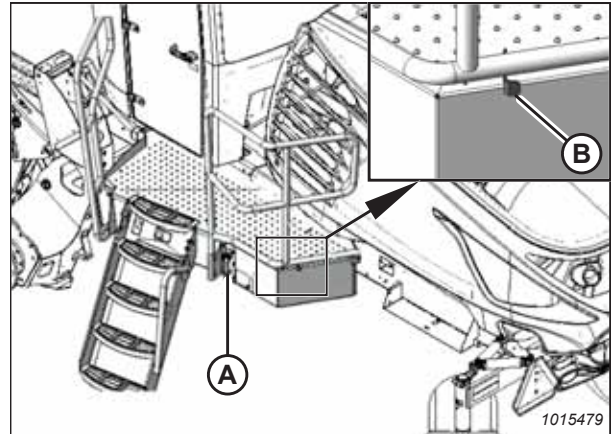

Figure 5.40: Left Platform

4. Retrieve hydraulic hoses (A) from the header and route the hose bundle under the windrower frame.

NOTE:

Adding anti-seize compound to the hose holder pin will make future removal easier.

5. Insert pin (B) into hole (C) in the windrower frame.

IMPORTANT:

Route the hydraulic hoses as straight as possible, avoiding wear points that could damage the hoses. To prevent abrasion damage, the hoses should have enough slack to pass by the multicoupler bracket without contacting it. To adjust the slack in the hoses, loosen the clamps below pin (B), adjust the hoses, then retighten the hose holder.

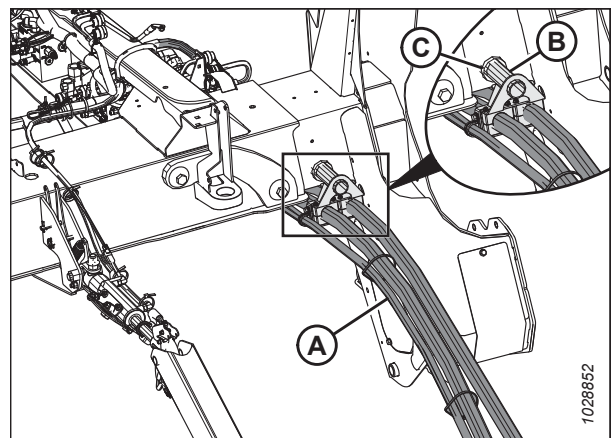

Figure 5.41: Hose Support Attachment

ATTACHING ROTARY DISC HEADER TO WINDROWER

6. Connect the hydraulic hoses to the windrower as follows:
 - a. Connect disc pressure hose (A) (fitted with red cable tie [B]) to hard plumb fitting (C) (fitted with a red cable tie) and torque the connection to 215 Nm (159 lbf-ft).
 - b. Connect disc return hose (D) to hard plumb fitting (E) and torque the connection to 215 Nm (159 lbf-ft).
 - c. Connect case drain hose (F) to fitting (G).

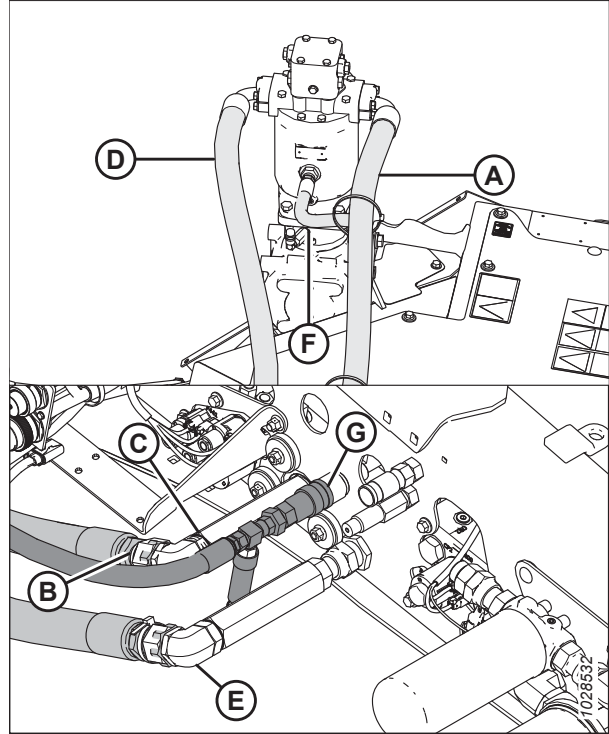

Figure 5.42: Hard-Plumbed Connections on R216 Rotary Disc Header-Ready Windrower

7. **Grass seed headers (GSS):** connect the additional four hoses supplied with the grass seed version of the header as follows:

- a. Install 45° fitting (A) in port R1. Connect hose (C) (blue cable tie) to fitting (A).

NOTE:

The other end of hose (C) connects to the grass seed module's drum on the right side of the header.

- b. Install 45° fitting (B) in port CP2. Connect hose (D) (red cable tie) to fitting (B).

NOTE:

The other end of hose (D) connects to the grass seed module's drum on the left side of the header.

- c. Connect hose (green cable tie) with female quick coupler (E) to coupler (F) as shown.
- d. Connect hose (yellow cable tie) with male quick coupler (G) to coupler (H) as shown.

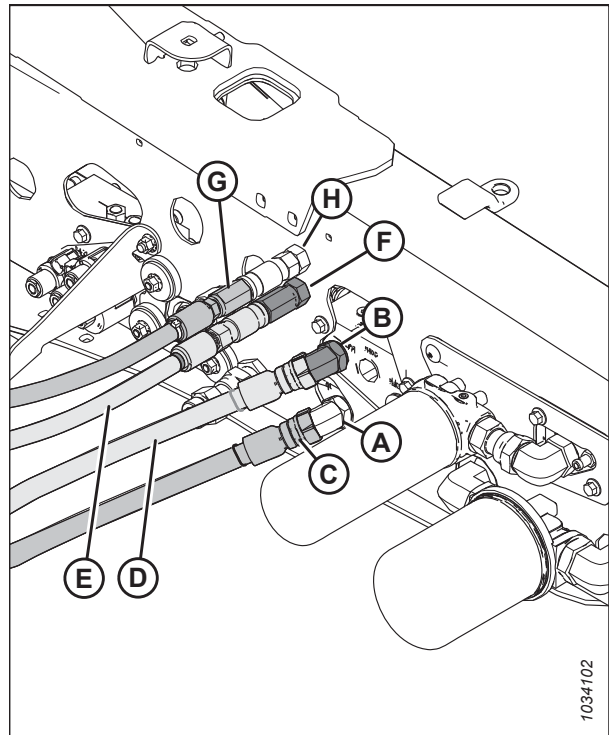

Figure 5.43: Grass Seed Hydraulic Connections – Rotary Disc Configuration

ATTACHING ROTARY DISC HEADER TO WINDROWER

- Free electrical harness (A) from adjustable strap (B).

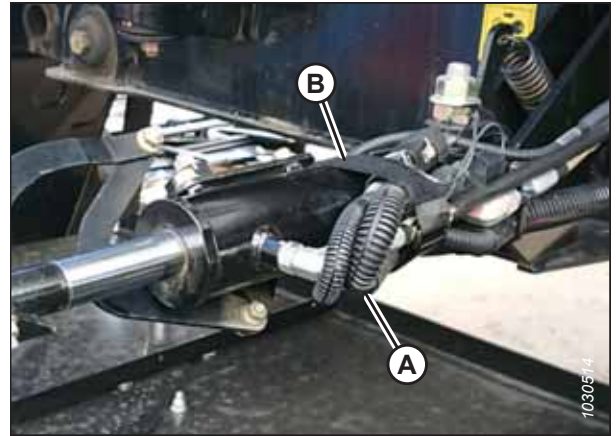

Figure 5.44: Electrical Harness Secured to Center-Link

- Connect main header harness (A) to adapter harness (B).
- Headers equipped with electric baffle control kit:** connect electric baffle control harness (C) to adapter harness (D).
- Grass seed headers (GSS):** connect actuator harness (C) to adapter harness (D).

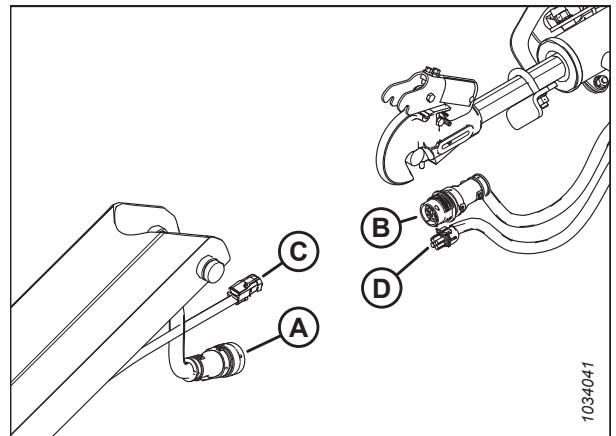

Figure 5.45: Electrical Harness Connection at Center-Link

- Push latch (A) to unlock platform (B).

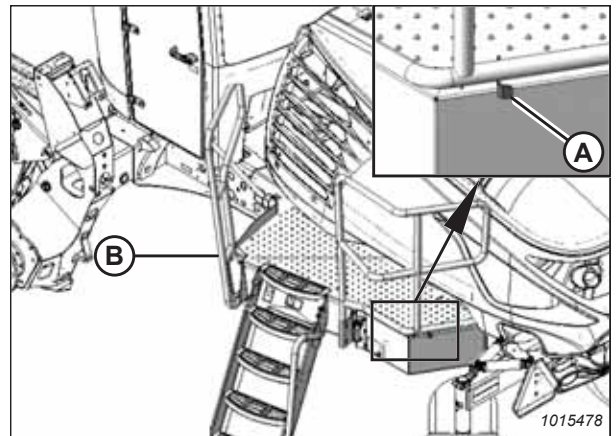

Figure 5.46: Left Platform

ATTACHING ROTARY DISC HEADER TO WINDROWER

13. Pull platform (A) toward the cab until it stops and the latch is engaged.

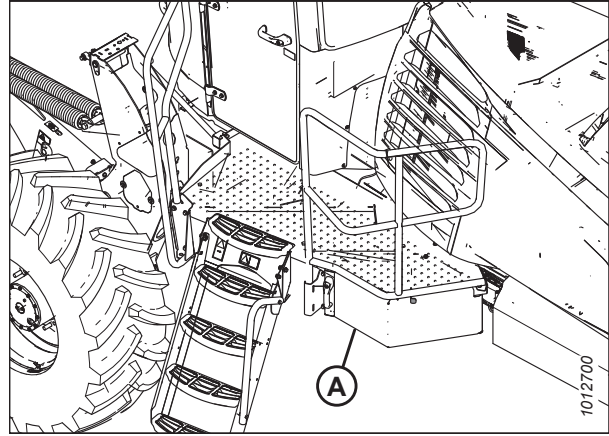

Figure 5.47: Left Platform

DANGER

Ensure that all bystanders have cleared the area.

14. Clear all bystanders from the area.
15. Start the engine.
16. Extend center-link (A) fully. Ensure that there is some slack in harness (B).
17. Retract center-link (A) fully. Ensure that there is not an excessive amount of harness (B) hanging down.
18. Shut down the engine, and remove the key from the ignition.
19. Adjust harness (B) as needed.
20. Tighten all the cables along the harness.
21. If this is the first time the header is connected to the windrower, calibrate the header. For instructions, refer to [5.2 Calibrating M2 Series Windrower and Header on HarvestTouch™ Display, page 66](#).

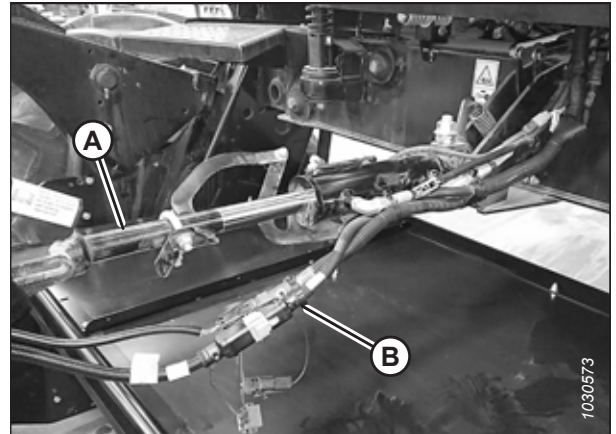

Figure 5.48: Electrical Connection

Rotary Disc-Only Configuration – Quick Coupler Connections

The rotary disc-only configuration allows the windrower to operate with compatible rotary disc headers. Attaching the header's hydraulic connections to the windrower's ports using quick couplers does not require any additional tools or hardware.

DANGER

To prevent bodily injury or death from the unexpected start-up of the machine, always stop the engine and remove the key from the ignition before making adjustments to the machine.

CAUTION

Do NOT stand on an unlocked platform. It is unstable and may cause you to fall.

IMPORTANT:

To prevent contamination of the hydraulic system, use a clean rag to remove dirt and moisture from all (fixed and movable) hydraulic couplers.

1. Shut down the engine, and remove the key from the ignition.

ATTACHING ROTARY DISC HEADER TO WINDROWER

2. Approach platform (A) on the left side of the windrower. Ensure that the cab door is closed.
3. Push latch (B) and pull platform (A) toward the walking beam until it stops and the latch engages.

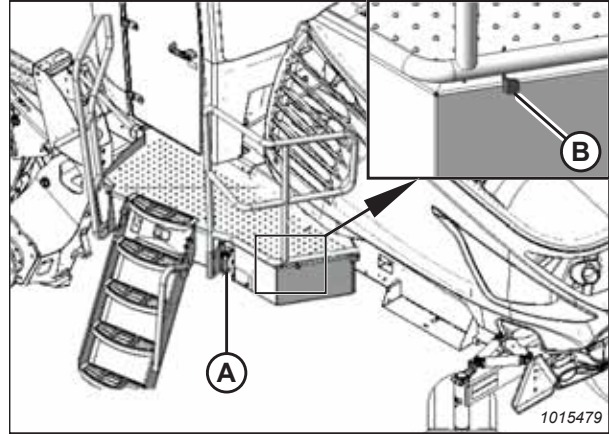

Figure 5.49: Left Platform

4. Retrieve hydraulic hoses (A) from the header and route the hose bundle under the windrower frame.

NOTE:

Adding anti-seize compound to the hose holder pin will make future removal easier.

5. Insert pin (B) into hole (C) in the windrower frame.

IMPORTANT:

Route the hydraulic hoses as straight as possible, avoiding wear points that could damage the hoses. To prevent abrasion damage, the hoses should have enough slack to pass by the multicoupler bracket without contacting it. To adjust the slack in the hoses, loosen the clamps below pin (B), adjust the hoses, then retighten the hose holder.

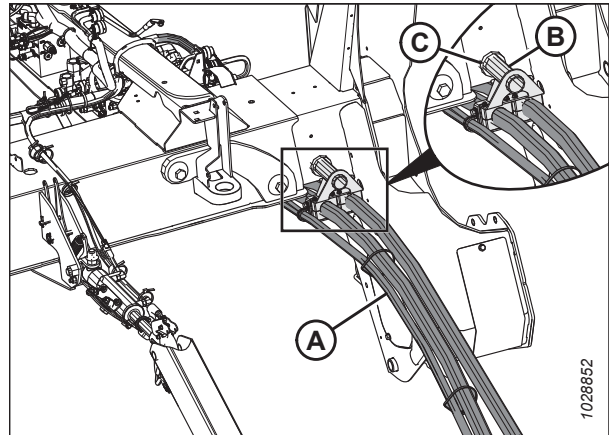

Figure 5.50: Hose Support Attachment

6. Connect the hydraulic fittings to the hydraulic hoses as follows:

NOTE:

Two quick couplers and two elbow fittings are supplied in the Quick Coupler kit (MD #B6277).

- a. Attach 90° elbow fitting (A) and 1 in. female coupler fitting (B) to disc pressure hose (C).
- b. Attach 90° elbow fitting (A) and 1 in. male coupler fitting (D) to disc return hose (E).

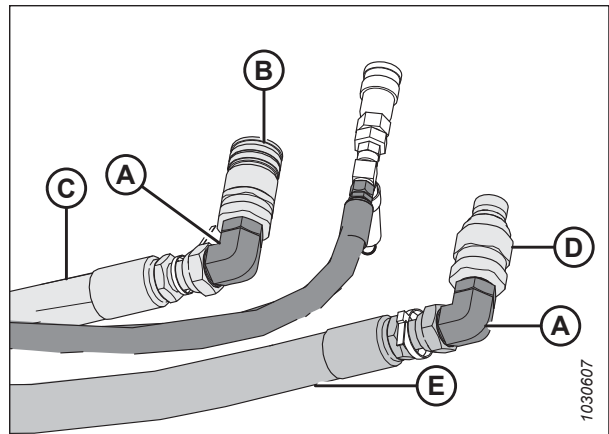

Figure 5.51: Header Hydraulic Fittings

ATTACHING ROTARY DISC HEADER TO WINDROWER

7. Connect the header's hydraulic hoses to the windrower as follows:
 - a. Connect disc pressure hose (A) to coupler (B) as shown.
 - b. Connect disc return hose (C) to coupler (D) as shown.
 - c. Connect case drain hose (E) to fitting (F), ensuring that the connection is oriented so that the relief valve points toward the ground.

NOTE:

Loosen and retighten fitting (F) as needed to ensure that the relief valve is pointing straight down as shown.

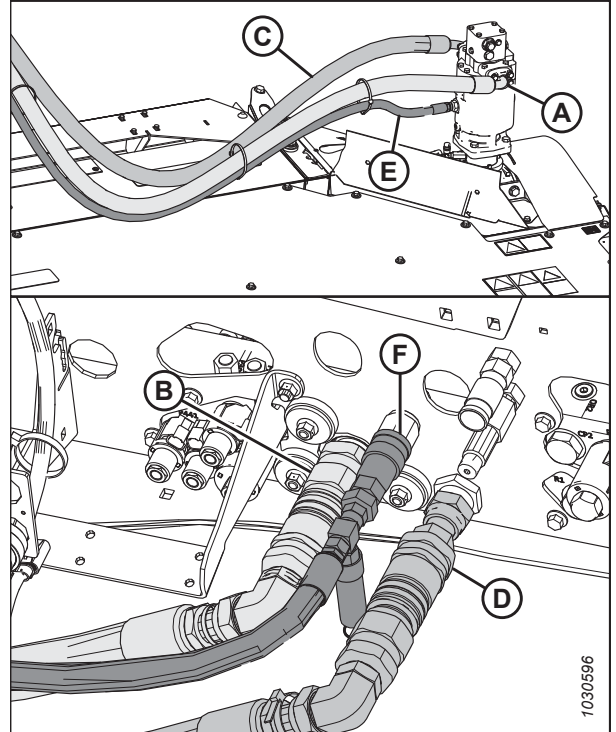

Figure 5.52: Hydraulics and Electrical – Rotary Disc Configuration with Quick Couplers Installed

8. **Grass seed headers (GSS):** connect the additional four hoses supplied with the grass seed version of the header as follows:

- a. Install 45° fitting (A) in port R1. Connect hose (C) (blue cable tie) to fitting (A).

NOTE:

The other end of hose (C) connects to the grass seed module's drum on the right side of the header.

- b. Install 45° fitting (B) in port CP2. Connect hose (D) (red cable tie) to fitting (B).

NOTE:

The other end of hose (D) connects to the grass seed module's drum on the left side of the header.

- c. Connect the hose (green cable tie) with female quick coupler (E) to coupler (F) on the windrower.
- d. Connect the hose (yellow cable tie) with male quick coupler (G) to coupler (H) on the windrower.

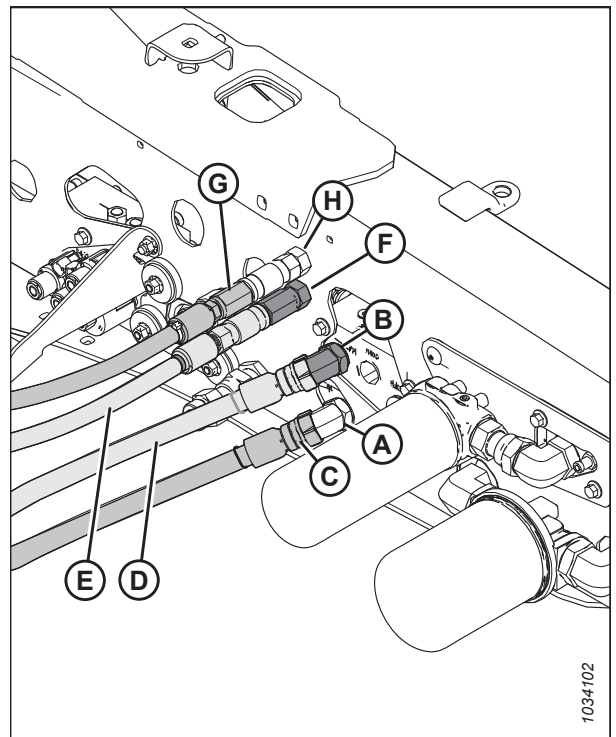

Figure 5.53: Grass Seed Hydraulic Connections – Rotary Disc Configuration

ATTACHING ROTARY DISC HEADER TO WINDROWER

- Free electrical harness (A) from adjustable strap (B).

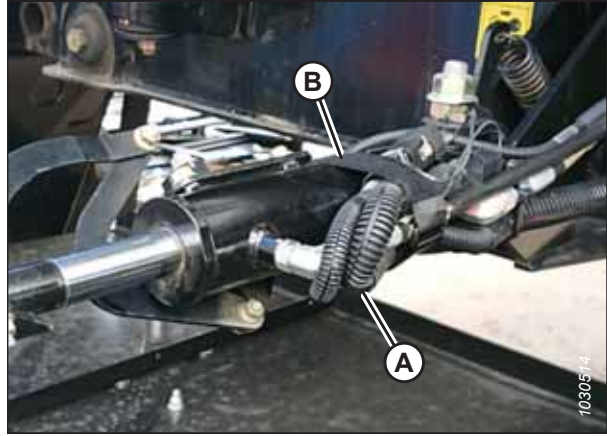

Figure 5.54: Electrical Harness Secured to Center-Link

- Connect main header harness (A) to adapter harness (B).
- Headers equipped with electric baffle control kit:** connect electric baffle control harness (C) to adapter harness (D).
- Grass seed headers (GSS):** connect actuator harness (C) to adapter harness (D).

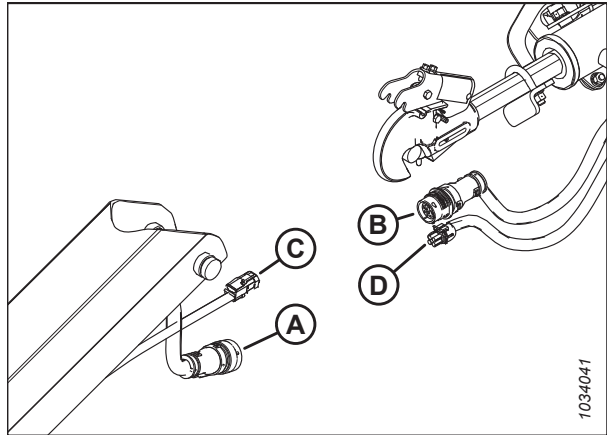

Figure 5.55: Electrical Harness Connection at Center-Link

- Push latch (A) to unlock platform (B).

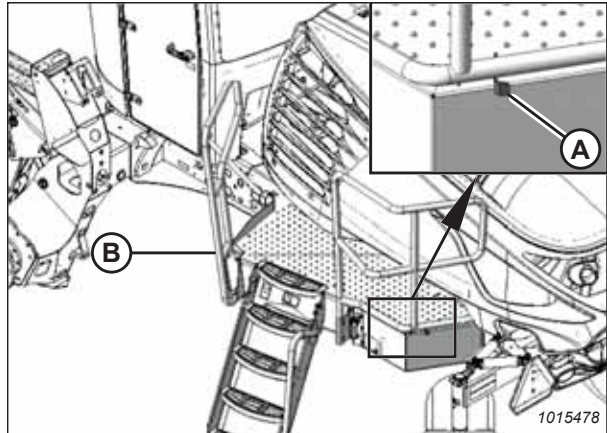

Figure 5.56: Left Platform

ATTACHING ROTARY DISC HEADER TO WINDROWER

14. Pull platform (A) toward the cab until it stops and the latch is engaged.

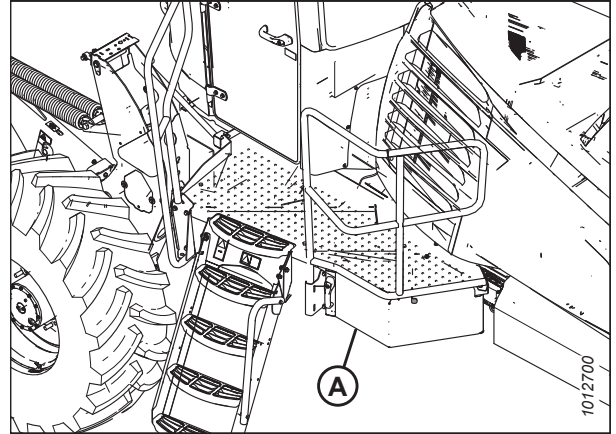

Figure 5.57: Left Platform

DANGER

Ensure that all bystanders have cleared the area.

15. Clear all bystanders from the area.
16. Start the engine.
17. Extend center-link (A) fully. Ensure that there is some slack in harness (B).
18. Retract center-link (A) fully. Ensure that there is not an excessive amount of harness (B) hanging down.
19. Shut down the engine, and remove the key from the ignition.
20. Adjust harness (B) as needed.
21. Tighten all the cables along the harness.
22. If this is the first time the header is connected to the windrower, calibrate the header. For instructions, refer to [5.2 Calibrating M2 Series Windrower and Header on HarvestTouch™ Display, page 66](#).

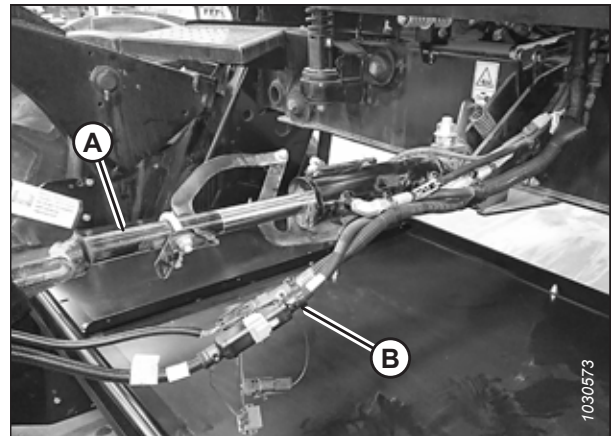

Figure 5.58: Electrical Connection

5.2 Calibrating M2 Series Windrower and Header on HarvestTouch™ Display

The HarvestTouch™ Display recognizes when a header is attached to the windrower and determines which systems will require calibration.

The following sensors may require calibration, depending on the type of header attached to the windrower:

- Header height
- Header angle
- Header float left
- Header float right
- Reel height
- Reel fore-aft
- Swath compressor
- Knife drive

Refer to the following topics for information on calibrating header systems:

- [5.3 Calibrating Knife Drive on HarvestTouch™ Display – M2 Series Windrowers, page 67](#)
- [5.4 Calibrating Header Position Sensors on HarvestTouch™ Display – M2 Series Windrowers, page 71](#)

5.3 Calibrating Knife Drive on HarvestTouch™ Display – M2 Series Windrowers

When a header is attached to the windrower, the windrower’s HarvestTouch™ Display will recognize the header ID and choose the appropriate settings for that header. Before it can be operated, however, the header’s knife drive must be calibrated to ensure that the knife drive pump output is accurate.

⚠ DANGER

Ensure that all bystanders have cleared the area.

NOTE:

This calibration **MUST** be performed with the engine running and the header engaged.

1. Start the engine.
2. Engage the header.

NOTE:

Once the header is engaged, header gauges (A) will appear on the HarvestTouch™ Display home page.

3. Select MENU (B) icon.

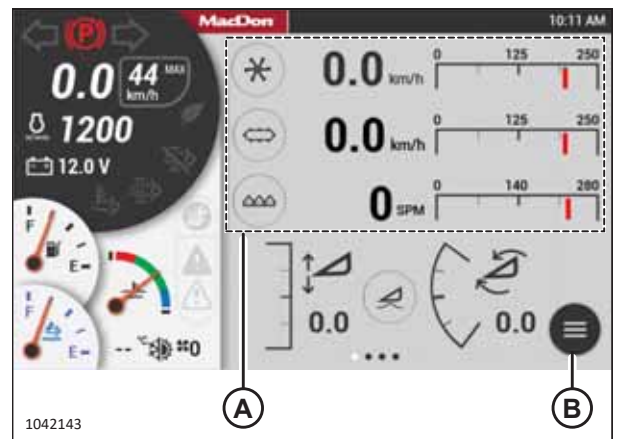

Figure 5.59: HarvestTouch™ Display

4. Select SETUP (A).

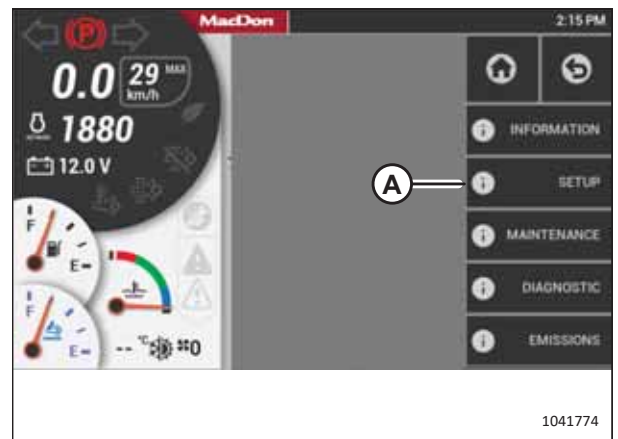

Figure 5.60: Main Menu

ATTACHING ROTARY DISC HEADER TO WINDROWER

5. Select WINDROWER (A).

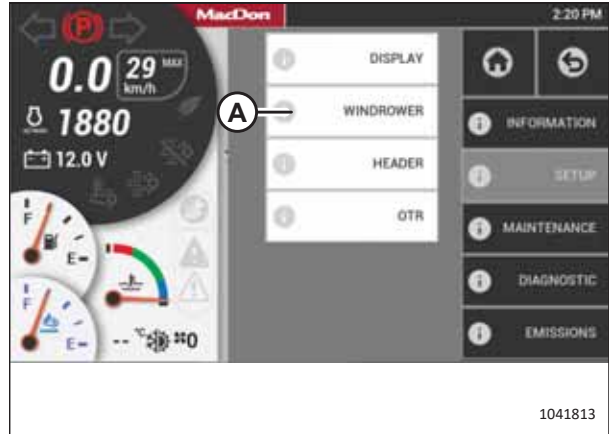

Figure 5.61: Setup Menu

6. Select CALIBRATION (A).

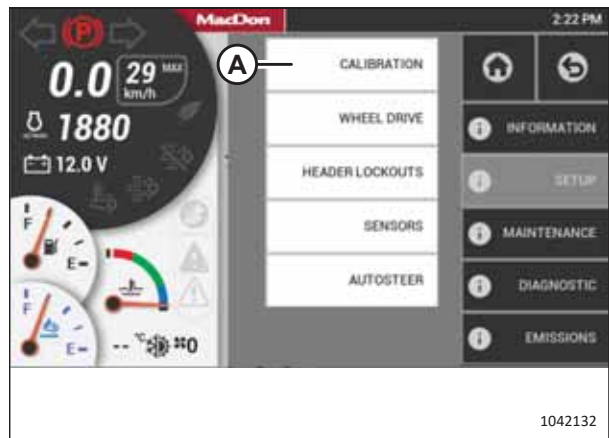

Figure 5.62: Setup Menu

7. Select KNIFE DRIVE (A).

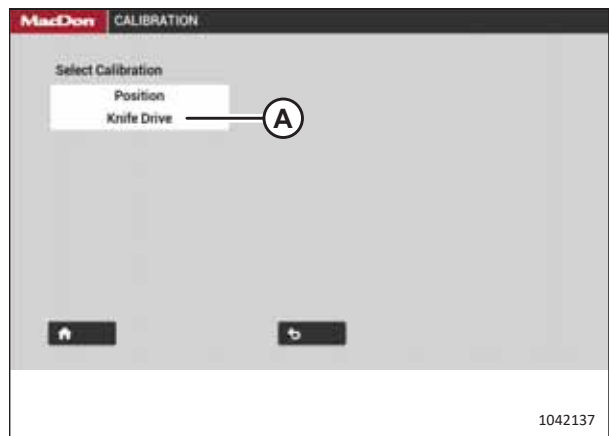

Figure 5.63: Calibration Selection Page

ATTACHING ROTARY DISC HEADER TO WINDROWER

8. Select PLAY icon (A).

NOTE:

The PLAY icon will only appear if the header is engaged.



Figure 5.64: Engage Header Warning

9. The display changes to show that calibration has started. The process should automatically proceed through all nine stages.

NOTE:

If the engine speed is less than 1500 rpm before calibration, the system will raise the engine speed to 1500 rpm.

NOTE:

During the calibration process, the speed of the header and the engine will fluctuate.

NOTE:

Select X icon (A) on the screen or use the HEADER DISENGAGE switch at any time during the calibration process to exit the procedure without saving your progress. The engine will resume the speed at which it was operating before the calibration process began.



Figure 5.65: Calibration Page

ATTACHING ROTARY DISC HEADER TO WINDROWER

NOTE:

If error message (A) appears during the calibration process, follow the instructions in the message to fix the error. Select X icon (B) to exit the message. If the knife calibration process fails:

- Confirm that the engine and the hydraulics are at operating temperature.
 - Confirm that the hydraulic system is free of any restrictions and is in working order.
 - Confirm that the throttle is working:
 - Check the engine codes to confirm that the engine is not derated or throttle-inhibited.
 - The throttle is controlled via the powertrain's CAN network 1. Check the network's wiring and connectors for an open or intermittent connection.
 - Confirm that the sensor mounting is secured properly and that the sensor's gap is set correctly.
 - Check the sensor wiring and connectors for an intermittent connection.
 - Replace the sensor.
10. Once the calibration process completes all nine stages, the message CALIBRATING COMPLETED appears. Select X icon (A) to exit the page.

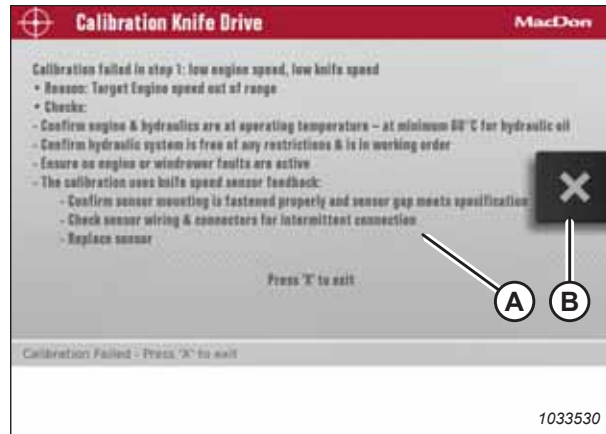

Figure 5.66: Calibration Page



Figure 5.67: Calibration Page

5.4 Calibrating Header Position Sensors on HarvestTouch™ Display – M2 Series Windrowers

The header position sensors need to be recalibrated whenever the HarvestTouch™ Display is replaced, a position sensor is replaced, sensor readouts are erratic, a pump has been replaced, or when a new header type or attachment is connected to the windrower.

DANGER

Ensure that all bystanders have cleared the area.

NOTE:

This calibration **MUST** be performed with the engine running and the header engaged.

1. Start the engine.
2. Engage the header.

NOTE:

Once the header is engaged, header gauges (A) will appear on the HarvestTouch™ Display home page.

3. Select MENU (B) icon.

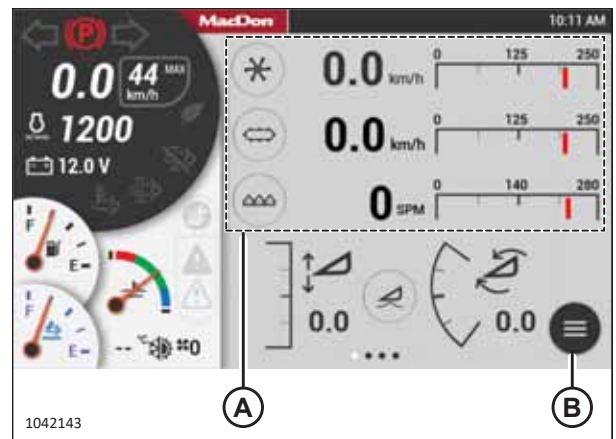

Figure 5.68: HarvestTouch™ Display

4. Select SETUP (A).

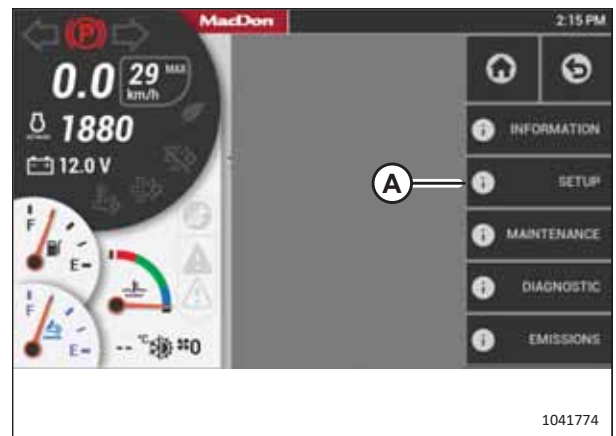

Figure 5.69: Main Menu

ATTACHING ROTARY DISC HEADER TO WINDROWER

5. Select CALIBRATION (A).



Figure 5.70: Setup Menu

6. Select POSITION (A).



Figure 5.71: Calibration Selection Page

7. Select PLAY icon (A).

NOTE:

The PLAY icon will only appear if the header is engaged.



Figure 5.72: Engage Header Warning

ATTACHING ROTARY DISC HEADER TO WINDROWER

- The calibration will attempt the first calibration stage.

NOTE:

Selecting X icon (A), HOME, or BACK, or pressing any of the ground speed lever (GSL) buttons at any time during calibration will EXIT the calibration process without saving your progress. The engine speed will return to the original rpm before starting the calibration process.

NOTE:

If a sensor goes out of its normal operating range during the calibration process, calibration will stop and a message will appear on the screen indicating that a sensor is out of range.

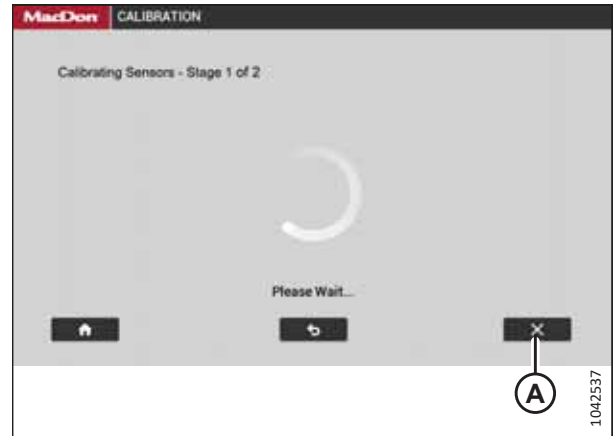

Figure 5.73: Calibration Page

- When the first stage of the calibration is complete, select PLAY icon (A) on the screen to continue with the second stage of the calibration process.



Figure 5.74: Calibration Page

NOTE:

If the voltage of any sensor falls below its acceptable range during calibration, a message appears afterward with a list of sensors reporting out-of-range voltages. Adjust the sensors as needed and repeat the calibration process from the beginning.



Figure 5.75: Sample of Failed Calibration Display Message

ATTACHING ROTARY DISC HEADER TO WINDROWER

- When the second stage of calibration is complete, calibration is complete. Select RESUME icon (A) on the screen to configure the HEADER FLOAT setting, or select the HOME or BACK icons to exit the screen.

NOTE:

The engine speed returns to the speed prior to calibration when the second stage of the calibration is complete.

- Proceed to Chapter 6 *Unpacking the Curtain*, page 151.

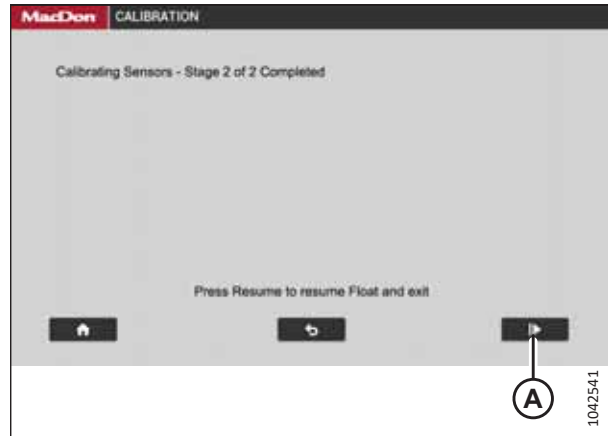

Figure 5.76: Calibration Page

5.5 Attaching R2 Series Rotary Disc Header to M1 Series Windrower

The windrower's support feet and center-link will need to be connected to the rotary disc header. The windrower may be equipped with an optional self-aligning hydraulic center-link, which allows control over the vertical position of the center-link from the cab.

DANGER

To prevent bodily injury or death from the unexpected startup of the machine, always stop the engine and remove the key from the ignition before leaving the operator's seat for any reason.

DANGER

Ensure that all bystanders have cleared the area.

IMPORTANT:

To attach an R216 SP Rotary Disc Header to an M1 Series Windrower previously configured for a D1X Series Draper Header, ensure that two shield mount plates (A) (MD #307045) are attached to the windrower and the forming shield.

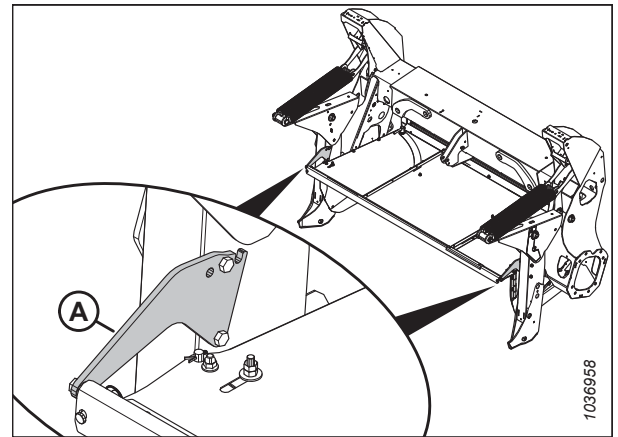

Figure 5.77: Shield Mount Plates on Forming Shield

1. Shut down the engine, and remove the key from the ignition.
2. **Windrowers equipped with a hydraulic center-link without self-alignment:** Remove pin (A) and raise center-link (B) until the hook is above the attachment pin on the header. Replace pin (A) to hold the center-link in place.

IMPORTANT:

Ensure that the center-link is positioned high enough that it does not contact the header as the windrower approaches the header.

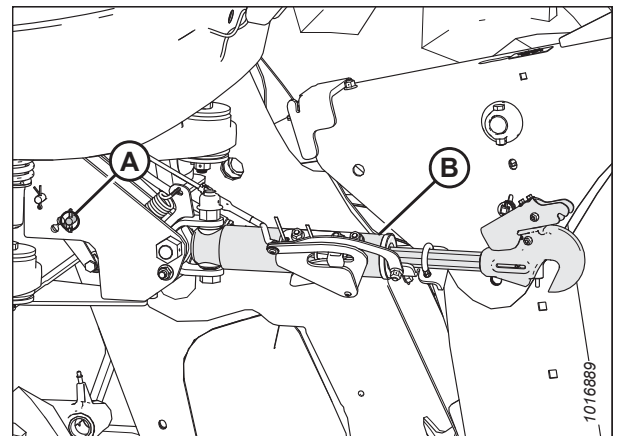

Figure 5.78: Hydraulic Center-Link

ATTACHING ROTARY DISC HEADER TO WINDROWER

3. Remove hairpin (A) from clevis pin (B), and remove the pin from header support (C) on both sides of the header.
4. Start the engine.

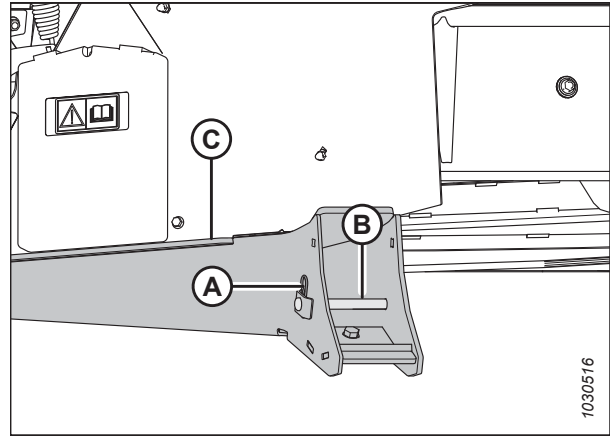

Figure 5.79: Header Support

5. Lift header support (A) and place four 35 x 89 mm (2 x 4 in.) blocks (B) under the header support. Ensure that the boot's bottom edge (C) is parallel with the ground.

NOTE:

Do **NOT** stack blocks (B) crosswise; doing so can make the header unstable when you are attempting to connect the header and the windrower. Stack blocks (B) so that they are aligned with each other.

6. Repeat Step 5, [page 76](#) on the opposite side of the header.

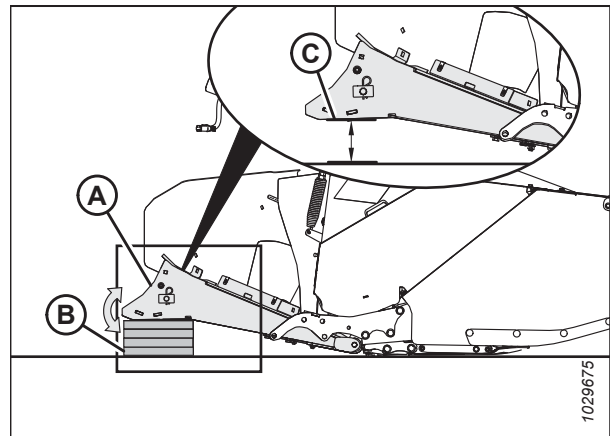

Figure 5.80: Header Support

7. **If the header lift legs will be lowered WITH a header or weight box attached**, proceed to Step 11, [page 77](#).

If the header lift legs will be lowered WITHOUT a header or weight box attached to the windrower, fully release the tension in header float springs (A):

- If the Harvest Performance Tracker (HPT) displays a message saying that the float should be removed, then remove the float and proceed to Step 11, [page 77](#).
- If the HPT does **NOT** display a message saying that the float should be removed, then proceed to Step 8, [page 77](#) to remove the float manually.

IMPORTANT:

To lower the header lift legs without a header or weight box attached to the windrower, ensure that the tension on the float springs is fully released. This will prevent damage to the header lift linkages.

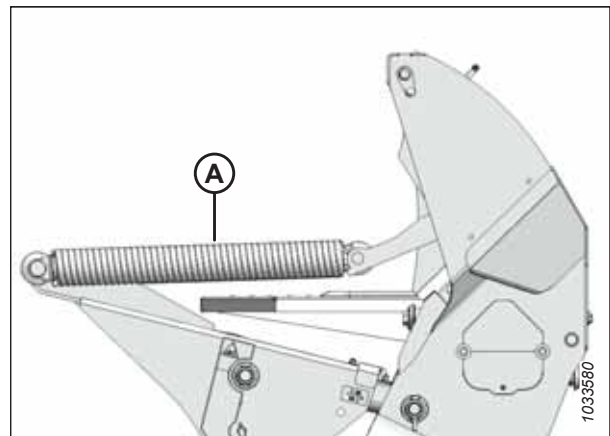

Figure 5.81: Header Float Springs

ATTACHING ROTARY DISC HEADER TO WINDROWER

8. Press rotary scroll knob (A) on the Harvest Performance Tracker (HPT) to highlight the QuickMenu options.
9. Rotate scroll knob (A) to highlight HEADER FLOAT symbol (B). Press the scroll knob to select it. The Float Adjust page will appear.



Figure 5.82: HPT Display

10. Press soft key 3 (A) to remove the header float.

NOTE:

If the header float is active, the icon at soft key 3 displays Remove Float; if the header float has been removed, then the icon displays Resume Float.



Figure 5.83: HPT Display

11. Press HEADER DOWN switch (E) on the ground speed lever (GSL) to fully retract the header lift cylinders.
12. **Windrowers equipped with a self-aligning hydraulic center-link:** Press REEL UP switch (B) on the GSL to raise the center-link until the hook is above the attachment pin on the header.

IMPORTANT:

Ensure that the center-link is positioned high enough that it does not contact the header as the windrower approaches the header.

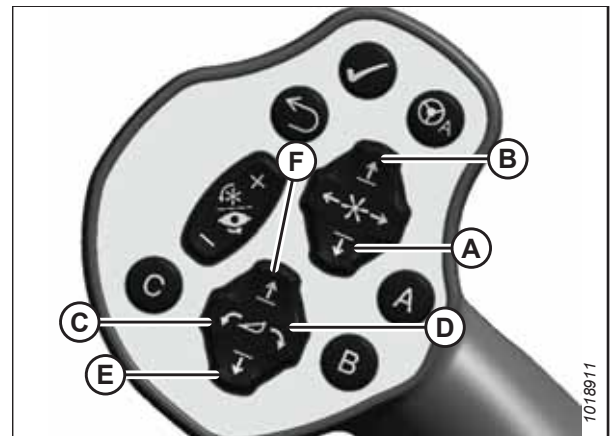

Figure 5.84: GSL

- | | |
|----------------------|--------------------|
| A - Reel Down | B - Reel Up |
| C - Header Tilt Down | D - Header Tilt Up |
| E - Header Down | F - Header Up |

ATTACHING ROTARY DISC HEADER TO WINDROWER

13. Drive the windrower slowly forward until feet (A) enter supports (B). Continue to drive slowly forward until the feet engage the supports and the header is nudged forward.
14. Ensure that feet (A) are properly engaged in supports (B).

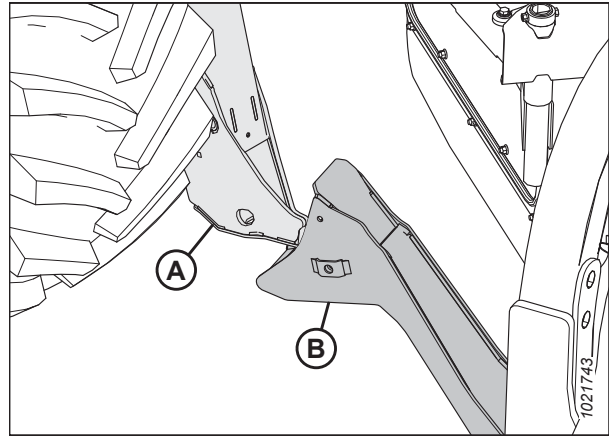

Figure 5.85: Header Support

15. Windrowers equipped with the Center-Link Alignment kit:

- a. Adjust the position of center-link cylinder (A) with the switches on the GSL until hook (B) is above the header attachment pin.

IMPORTANT:

Hook release (C) must be down to enable the self-locking mechanism to function.

- b. If hook release (C) is open (in the up position), shut down the engine, and remove the key from the ignition. Manually push hook release (C) down after the hook engages the header pin.
- c. Lower center-link (A) onto the header with the REEL DOWN switch on the GSL until the center-link locks into position and hook release (C) is down.
- d. Check that the center-link is locked onto the header by pressing the REEL UP switch on the GSL.

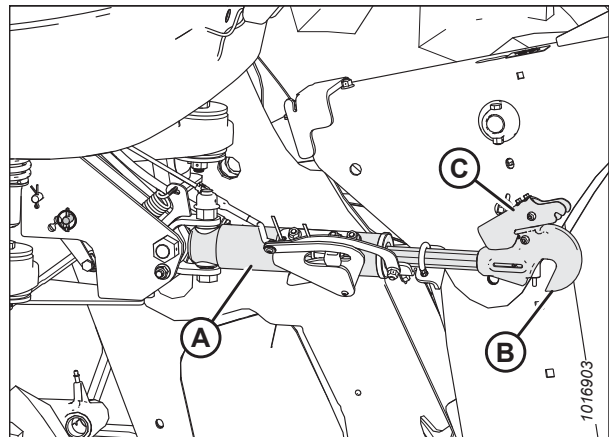

Figure 5.86: Hydraulic Center-Link

ATTACHING ROTARY DISC HEADER TO WINDROWER

16. Windrowers without the Center-Link Alignment kit:

- Press the HEADER TILT UP or HEADER TILT DOWN cylinder switches on the GSL to extend or retract the center-link cylinder until the hook is aligned with the header attachment pin.
- Shut down the engine, and remove the key from the ignition.
- Push down on rod end (B) of the link cylinder until the hook engages and locks onto the header pin.

IMPORTANT:

The hook release must be down to enable the self-locking mechanism to function. If the hook release is open (in the up position), manually push it down after the hook engages the pin.

- Check that center-link (A) is locked onto the header by pulling upward on rod end (B) of the cylinder.
- Start the engine.

- Press HEADER UP switch (A) to raise the header to its maximum height.

NOTE:

If one end of the header does **NOT** fully rise, rephase the lift cylinders as follows:

- Press and hold HEADER UP switch (A) until both cylinders stop moving.
- Continue to hold the switch for 3–4 seconds. The cylinders are now phased.

- Shut down the engine, and remove the key from the ignition.

- Engage the safety props on both lift cylinders as follows:

- Pull lever (A) toward you to release it, then rotate it toward the header to lower the safety prop onto the cylinder.
- Repeat the previous step for the opposite lift cylinder.

IMPORTANT:

Ensure that the safety props engage over the cylinder piston rods. If the safety prop does **NOT** engage properly, raise the header until the safety prop fits over the rod.

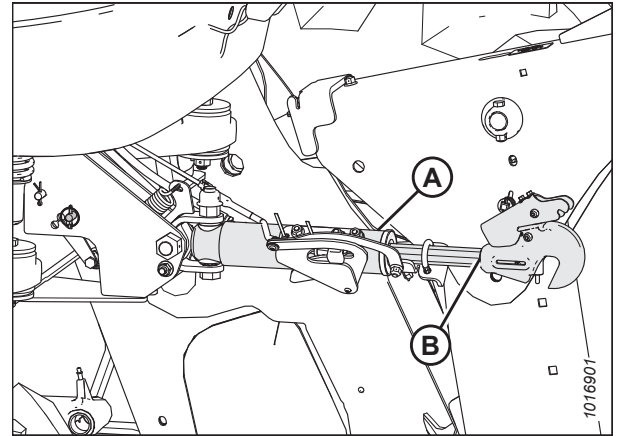

Figure 5.87: Hydraulic Center-Link



Figure 5.88: GSL

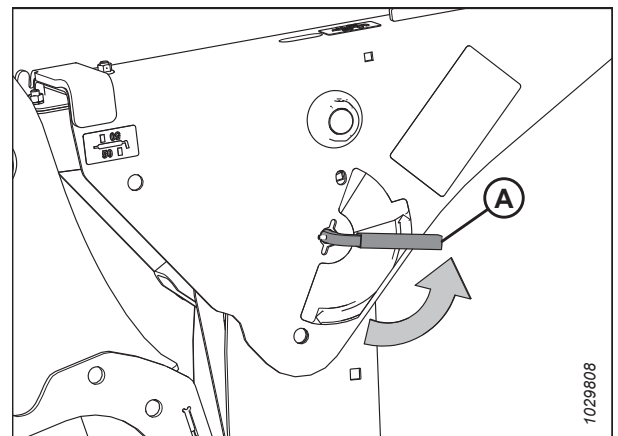

Figure 5.89: Safety Prop Lever

ATTACHING ROTARY DISC HEADER TO WINDROWER

20. Install clevis pin (A) through the support and the windrower lift arm. Secure the clevis pin with hairpin (B). Repeat this step on the opposite side of the header.

IMPORTANT:

Ensure that clevis pin (A) is fully inserted, and that the hairpin is installed behind the bracket.

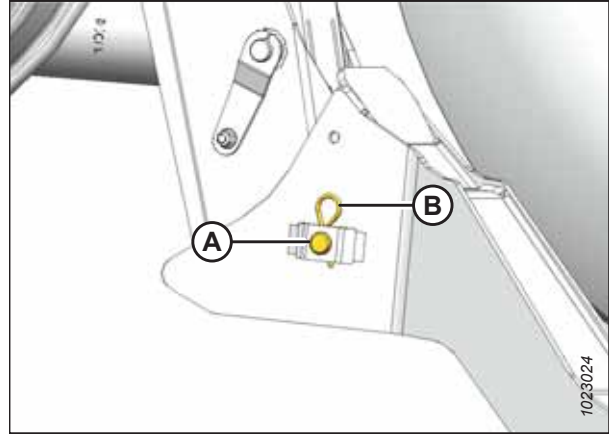

Figure 5.90: Header Support

21. Disengage the safety props on both lift cylinders as follows:
- Turn lever (A) away from the header to raise the safety prop until the lever locks into the vertical position.
 - Repeat the previous step for the opposite cylinder.

NOTE:

If the safety prop will **NOT** disengage, raise the header to release the prop.

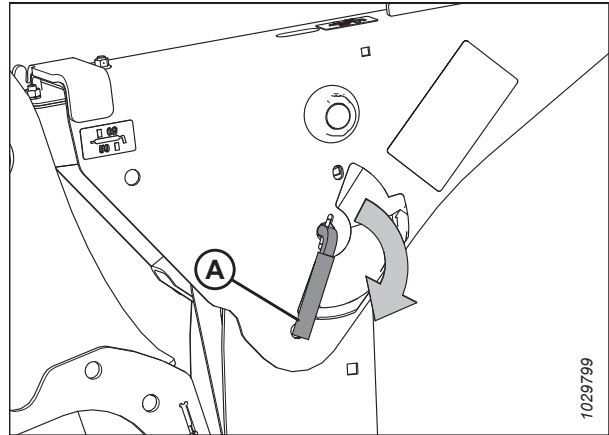

Figure 5.91: Safety Prop Lever

22. Start the engine.
23. Press HEADER DOWN switch (A) on the GSL to fully lower the header.
24. Shut down the engine, and remove the key from the ignition.

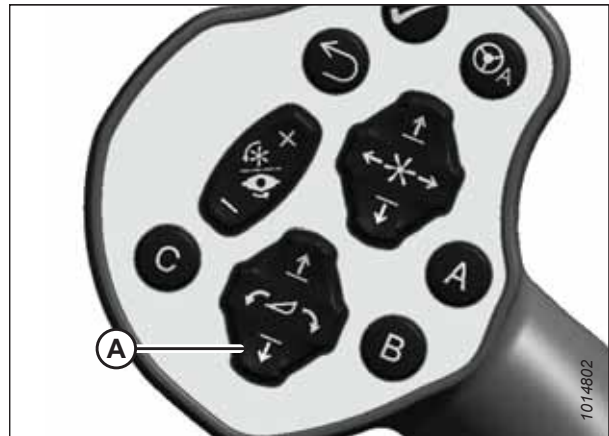

Figure 5.92: GSL

ATTACHING ROTARY DISC HEADER TO WINDROWER

25. Restore the header float manually by doing the following:
 - a. Press rotary scroll knob (A) on the HPT to highlight the QuickMenu options.
 - b. Rotate scroll knob (A) to highlight Header Float icon (B), and press the scroll knob to select it.



Figure 5.93: HPT Display

26. Press soft key 3 (A) to restore the header float.

NOTE:

If the header float is active, the icon at soft key 3 displays Remove Float; if the header float has been removed, then the icon displays Resume Float.

27. Shut down the engine, and remove the key from the ignition.



Figure 5.94: HPT Display

5.5.1 Attaching R2 Series Rotary Disc Header to M1240 Windrower

The R216 Rotary Disc Header with conditioner or grass seed (GSS) option can be attached to an M1240 Windrower.

Routing Electrical Harness – M1240 Windrower

A total of seven cable ties (A) secure electrical harness (B) in place alongside the windrower chassis harness and avoid rub/wear points that could damage the harnesses. Keep cable ties (A) loose on the harness until it has been routed on the header.

NOTE:

The cable ties are located in the manual storage case.

NOTE:

The windrower chassis harness is not shown in the illustration.

To route the R216 Rotary Disc Header electrical harness on the M1240 Windrower, follow these steps:

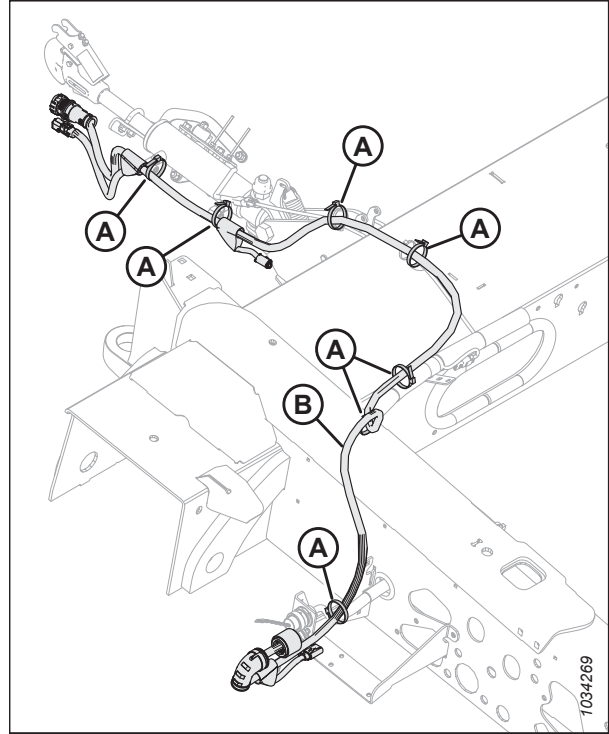

Figure 5.95: Cable Ties Securing Header Electrical Harness

1. Approach platform (A) on the left side of the windrower. Ensure that the cab door is closed.
2. Push latch (B) and pull platform (A) toward the walking beam until it stops and the latch engages.

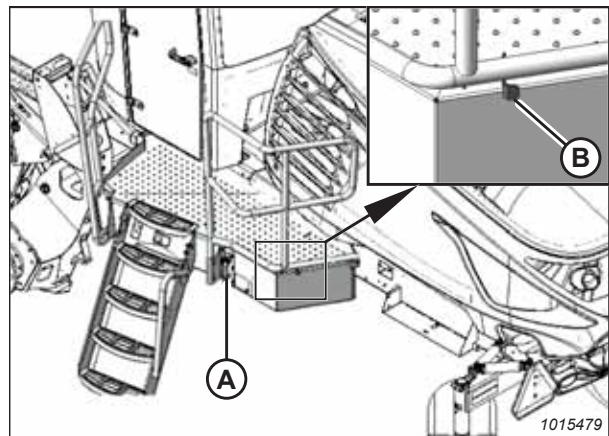

Figure 5.96: Left Platform

ATTACHING ROTARY DISC HEADER TO WINDROWER

- Retrieve header adapter harness (A) and adjustable strap (D). Loosely attach the harness to center-link (B) with two cable ties (C).

NOTE:

Cable ties (C) should bundle header adapter harness (A) with other hydraulic hoses from the windrower. The other hydraulic hoses are not shown in the illustration.

NOTE:

Do **NOT** tighten cable ties (C) on the harness at this point.

- Install velcro strap (D) around the center-link cylinder.

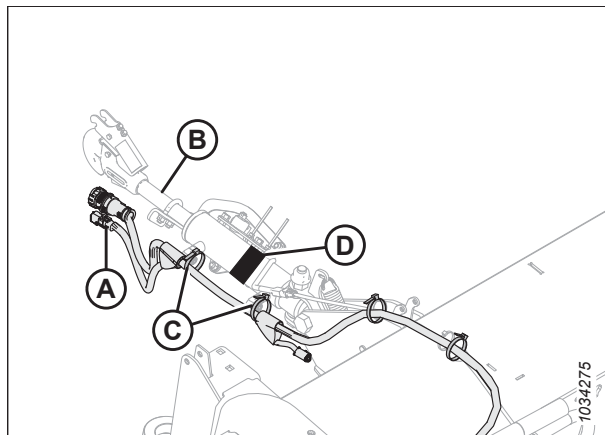

Figure 5.97: Electrical Harness Routed Along Center-Link with Cable Ties

- Route header adapter harness (A) over the windrower forward cross member and loosely secure it to windrower chassis harness (B) with three cable ties (C).

NOTE:

Do **NOT** tighten cable ties (C) on harness at this point.

NOTE:

The windrower chassis harness is only partially illustrated.

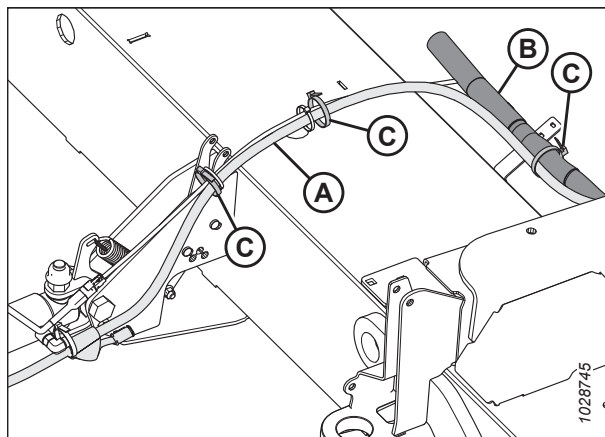

Figure 5.98: Forward Cross Member and Cable Ties

- Route header adapter harness (A) over windrower frame (B) towards the multicoupler base.
- Loosely secure header adapter harness (A) to windrower chassis harness (C) with one cable tie (D) near the windrower frame.

NOTE:

Do **NOT** tighten cable tie (D) on the harness at this point.

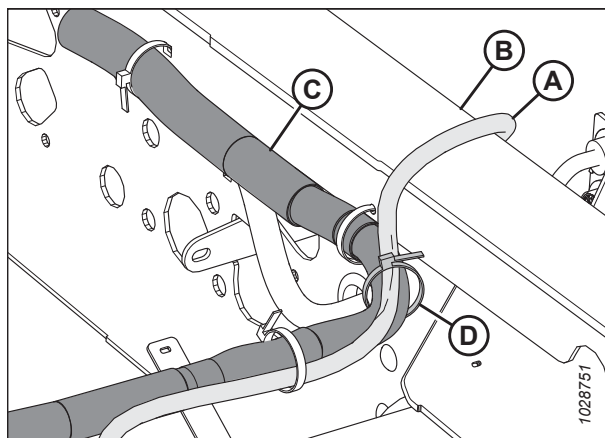

Figure 5.99: Electrical Harness Routing

ATTACHING ROTARY DISC HEADER TO WINDROWER

- Connect header adapter harness (A) to plug (B) set in multicoupler base (C).
- Secure header adapter harness (A) to windrower harness (D) with cable tie (E) to avoid rub/wear points that could damage the harnesses.

NOTE:

Ensure there is enough slack in harness (A) before securing it with cable tie (E) to maintain a minimum bend radius of 50 mm (2 in.) and avoid contact with multicoupler base (C).

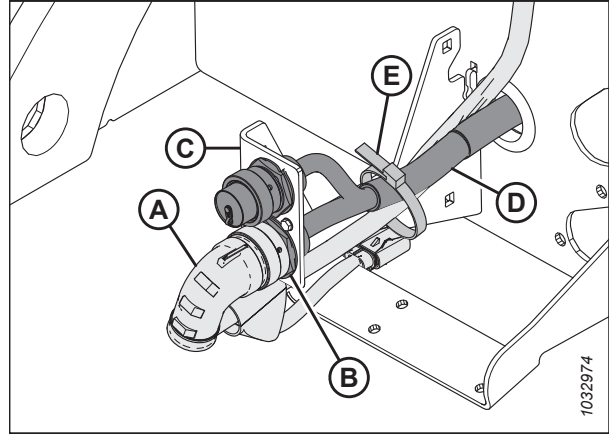

Figure 5.100: Electrical Connection

Connecting R2 Series Rotary Disc Header Hydraulic and Electrical Systems – M1240 Windrower

The header's hydraulic and electrical multicoupler will need to be connected to the windrower.

- Approach platform (A) on the left side of the windrower. Ensure that the cab door is closed.
- Push latch (B) and pull platform (A) toward the walking beam until it stops and the latch engages.

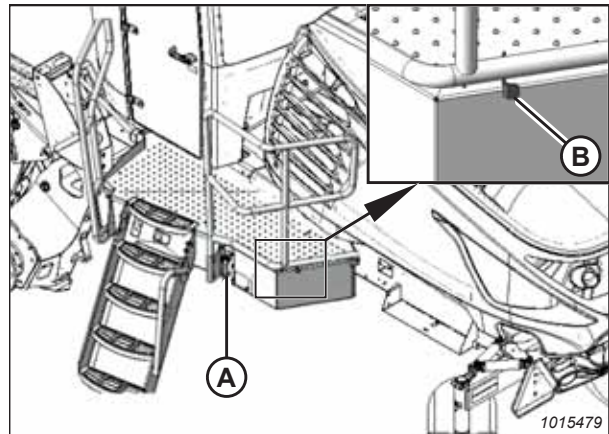

Figure 5.101: Left Platform

- Proceed to the relevant procedure:
 - Auger/rotary disc/draper-ready configuration (A):** For instructions, refer to [Auger/Rotary Disc/Draper-Ready Configuration – Quick Coupler Connections, page 85](#).

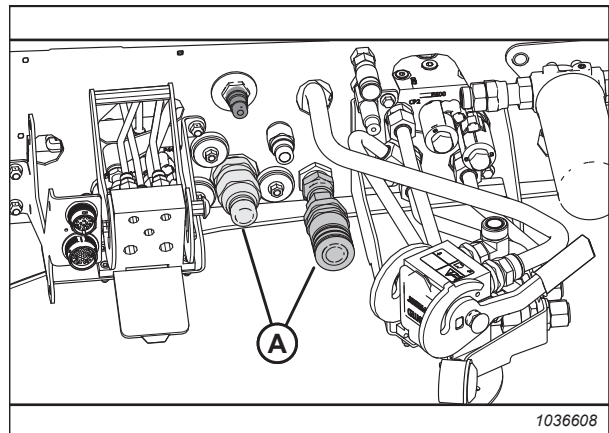

Figure 5.102: Header Hydraulic Configurations – Auger/Rotary Disc/Draper-Ready

ATTACHING ROTARY DISC HEADER TO WINDROWER

- **Rotary disc-only hard-plumbed configuration (A):** For instructions, refer to *Rotary Disc-Only Configuration – Hard-Plumbed Connections*, page 90.

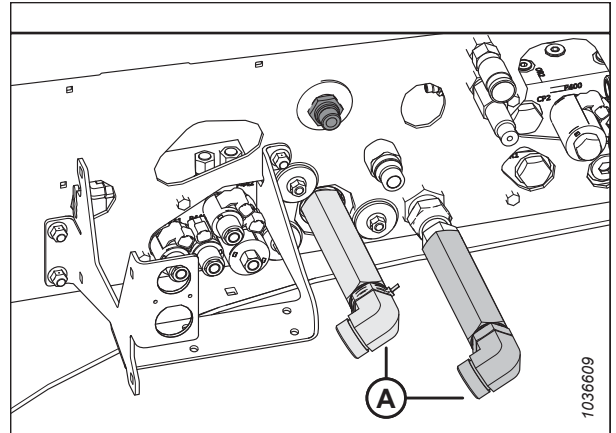

Figure 5.103: Header Hydraulics Configuration – Rotary Disc-Ready with Hard-Plumbed Connections

- **Rotary disc-ready configuration with quick couplers (A):** For instructions, refer to *Rotary Disc-Only Configuration – Quick Coupler Connections*, page 93.

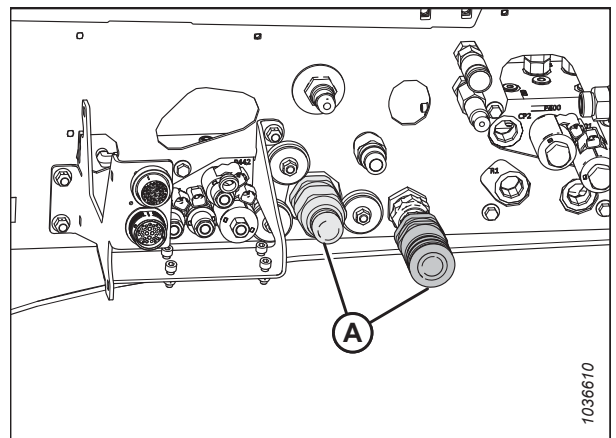

Figure 5.104: Header Hydraulics Configuration – Rotary Disc-Ready with Quick Couplers

Auger/Rotary Disc/Draper-Ready Configuration – Quick Coupler Connections

Windrowers with the auger/rotary disc/draper-ready configuration are equipped with the hydraulic connections needed to pair with an auger, rotary disc, or draper header.

IMPORTANT:

To prevent contamination of the hydraulic system, use a clean rag to remove dirt and moisture from all (fixed and movable) hydraulic couplers.

ATTACHING ROTARY DISC HEADER TO WINDROWER

1. Retrieve hydraulic hoses (A) from the header and route the hose bundle under the windrower frame.

NOTE:

Adding anti-seize compound to the hose holder pin will make future removal easier.

2. Insert pin (B) into hole (C) in the windrower frame.

IMPORTANT:

Route the hydraulic hoses as straight as possible, avoiding wear points that could damage the hoses. To prevent abrasion damage, the hoses should have enough slack to pass by the multicoupler bracket without contacting it. To adjust the slack in the hoses, loosen the clamps below pin (B), adjust the hoses, then retighten the hose holder.

3. Ensure that hose (A) is disconnected from windrower receptacle (B) and placed in storage cup (C) on the multicoupler.

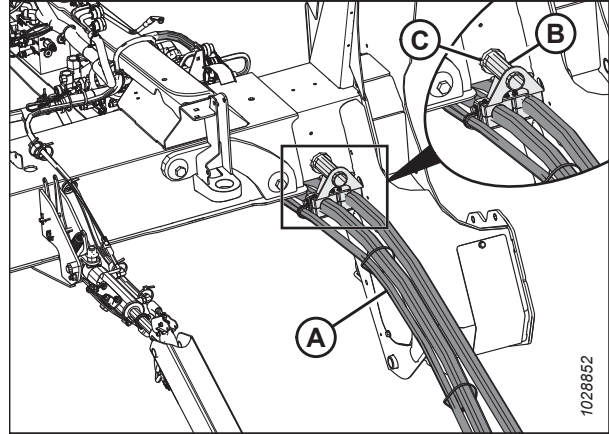

Figure 5.105: Hose Support Attachment

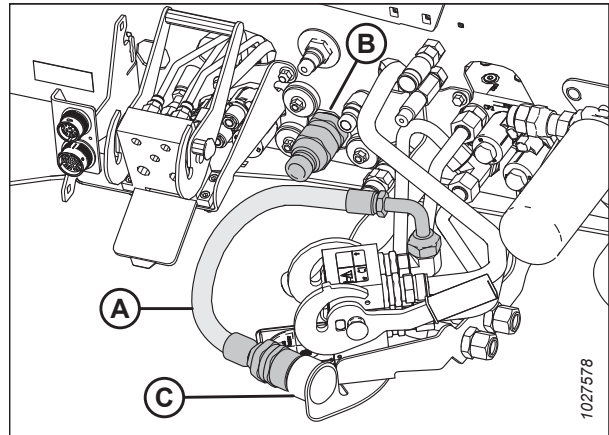

Figure 5.106: Couplers – Auger/Rotary Disc/Draper-Ready Configuration

4. Connect the hydraulic fittings to the hydraulic hoses as follows:

NOTE:

The two quick couplers and two elbow fittings are supplied in the Quick Coupler kit (MD #B6277).

- a. Attach 90° elbow fitting (A) and 1 in. female coupler fitting (B) to disc pressure hose (C).
- b. Attach 90° elbow fitting (A) and 1 in. male coupler fitting (D) to disc return hose (E).

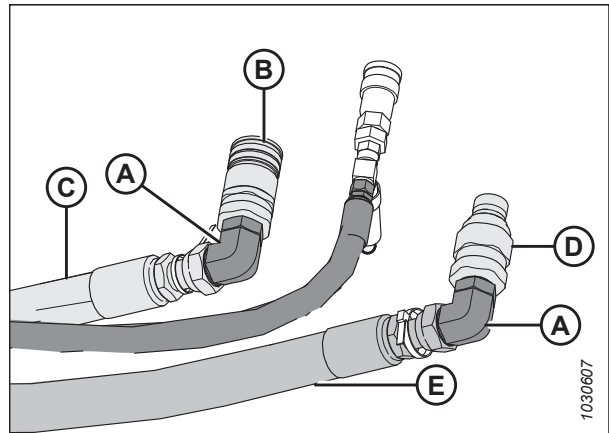

Figure 5.107: Header Hydraulic Fittings

ATTACHING ROTARY DISC HEADER TO WINDROWER

5. Connect the hydraulic hoses to the windrower as follows:
 - a. Connect disc pressure hose (A) to coupler (B).
 - b. Connect disc return hose (C) to coupler (D).
 - c. Connect case drain hose (E) to fitting (F) so that the relief valve points toward the ground.

NOTE:

Loosen and tighten fitting (F) as needed to ensure that the relief valve is pointing down.

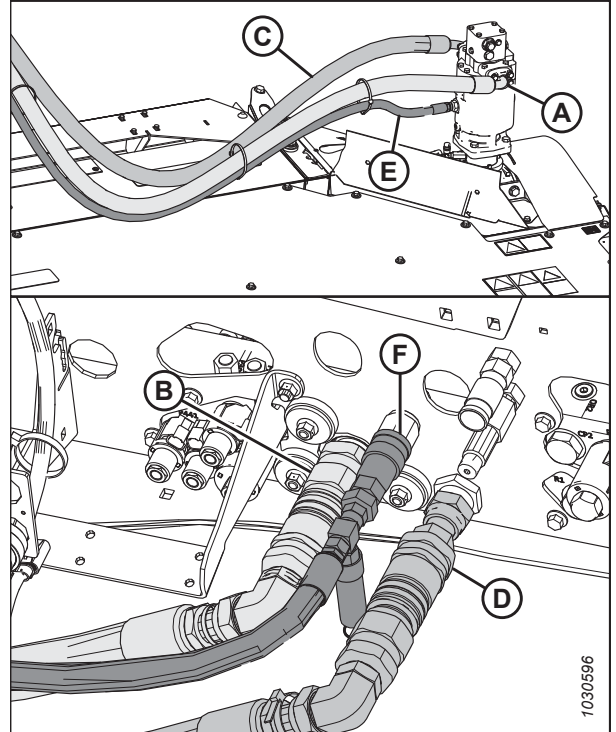

Figure 5.108: Hydraulics and Electrical – Auger/Rotary Disc/Draper-Ready Configuration

6. **Grass seed headers (GSS):** Connect the additional four hoses supplied with the grass seed version of the header as follows:
 - a. Connect the hose with the green cable tie with female quick coupler (A) to coupler (B) on the windrower frame.
 - b. Connect the hose with the yellow cable tie with male quick coupler (C) to coupler (D) on the windrower frame.
 - c. Connect hose (F) (red cable tie) to inboard bulkhead fitting (E).

NOTE:

The other end of hose (F) connects to the grass seed module's drum on the left side of the header.

- d. Connect hose (H) (blue cable tie) to outboard bulkhead fitting (G).

NOTE:

The other end of hose (H) connects to the grass seed module's drum on the right side of the header.

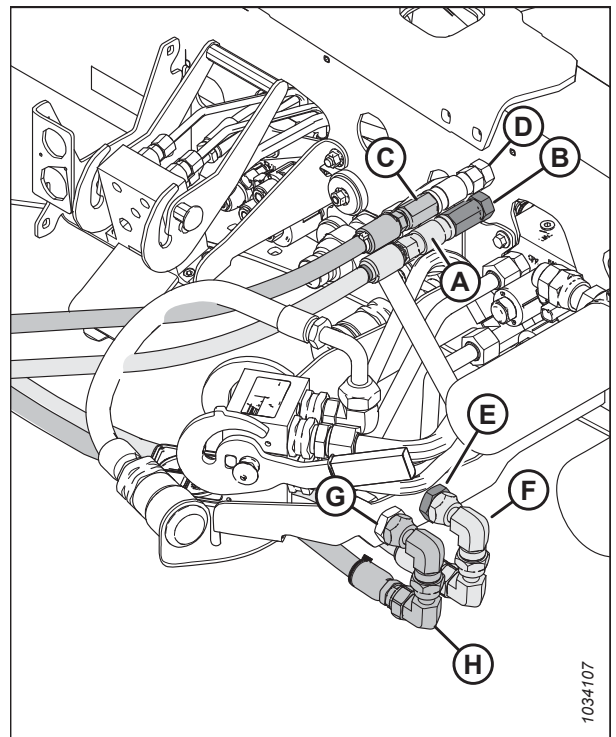

Figure 5.109: Grass Seed Hydraulic Connections – Auger/Rotary Disc/Draper—Ready Configuration

ATTACHING ROTARY DISC HEADER TO WINDROWER

- Free electrical harness (A) from adjustable strap (B).

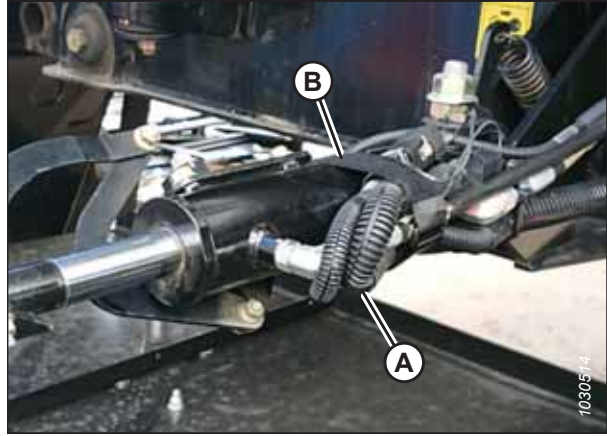

Figure 5.110: Electrical Harness Secured to Center-Link

- Connect main header harness (A) to adapter harness (B).
- Headers equipped with the electric baffle control kit:** Connect electric baffle control harness (C) to adapter harness (D).
- Grass seed headers (GSS):** Connect actuator harness (C) to adapter harness (D).

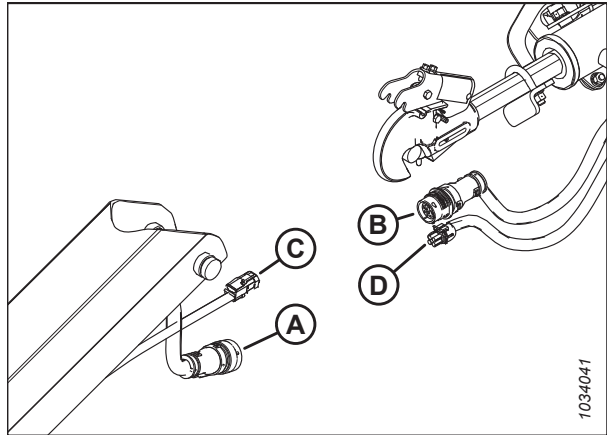

Figure 5.111: Electrical Harness Connection at Center-Link

- Push latch (A) to unlock platform (B).

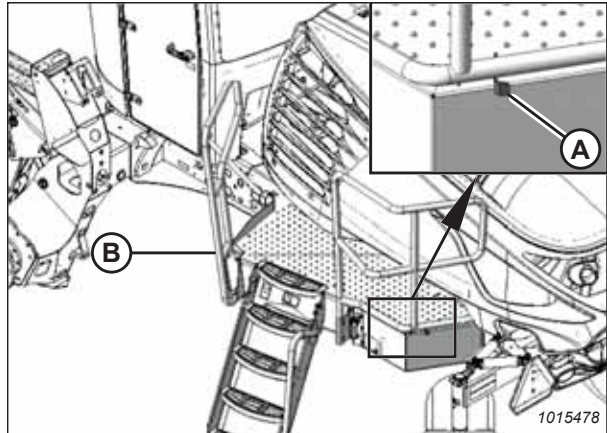

Figure 5.112: Left Platform

ATTACHING ROTARY DISC HEADER TO WINDROWER

12. Pull platform (A) toward the cab until it stops and the latch is engaged.

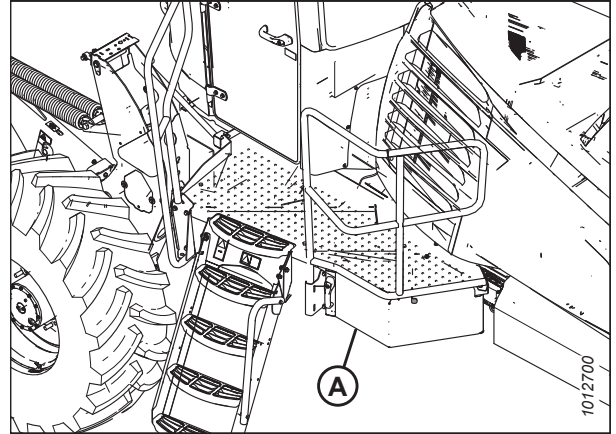

Figure 5.113: Left Platform

DANGER

Ensure that all bystanders have cleared the area.

13. Start the engine.
14. Extend center-link (A) fully. Ensure that there is some slack in harness (B).
15. Retract center-link (A) fully. Ensure that there is not an excessive amount of harness (B) hanging down.
16. Shut down the engine, and remove the key from the ignition.
17. Adjust harness (B) as needed.
18. Tighten all the cables along the harness.
19. If necessary, calibrate the knife drive. Calibrate the knife drive whenever you are:
 - Attaching the header to the windrower for the first time
 - Changing the speed sensor or hydraulic drive motor on the header
 - Changing the header drive pump associated with the knife drive, Harvest Performance Tracker (HPT), or the master controller on the windrower

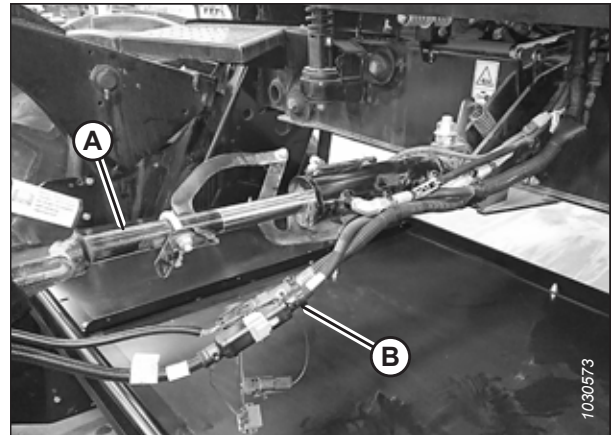

Figure 5.114: Electrical Connection

For instructions on calibrating the knife drive, refer to [5.6 Calibrating Knife Drive on Harvest Performance Tracker Display – M1 Series Windrowers, page 97](#).

ATTACHING ROTARY DISC HEADER TO WINDROWER

Rotary Disc-Only Configuration – Hard-Plumbed Connections

The rotary disc-only configuration allows the windrower to operate with compatible rotary disc headers. The hydraulic connections must be torqued correctly when using hard-plumbed fittings.

IMPORTANT:

To protect the hydraulic system from contamination, use a clean rag to remove dirt and moisture from all hydraulic couplers (fixed and movable).

1. Retrieve hydraulic hoses (A) from the header and route the hose bundle under the windrower frame.

NOTE:

Adding anti-seize compound to the hose holder pin will make future removal easier.

2. Insert pin (B) into hole (C) in the windrower frame.

IMPORTANT:

Route the hydraulic hoses as straight as possible, avoiding wear points that could damage the hoses. To prevent abrasion damage, the hoses should have enough slack to pass by the multicoupler bracket without contacting it. To adjust the slack in the hoses, loosen the clamps below pin (B), adjust the hoses, then retighten the hose holder.

3. Connect the hydraulic hoses to the windrower as follows:
 - a. Connect disc pressure hose (A) (fitted with red cable tie [B]) to hard plumb fitting (C) (fitted with a red cable tie) and torque the connection to 215 Nm (159 lbf-ft).
 - b. Connect disc return hose (D) to hard plumb fitting (E) and torque the connection to 215 Nm (159 lbf-ft).
 - c. Connect case drain hose (F) to fitting (G).

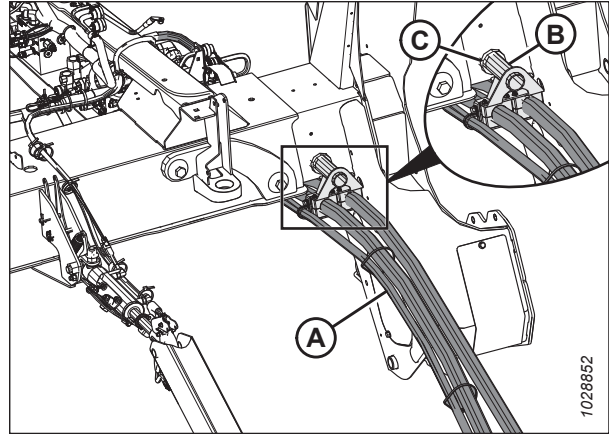

Figure 5.115: Hose Support Attachment

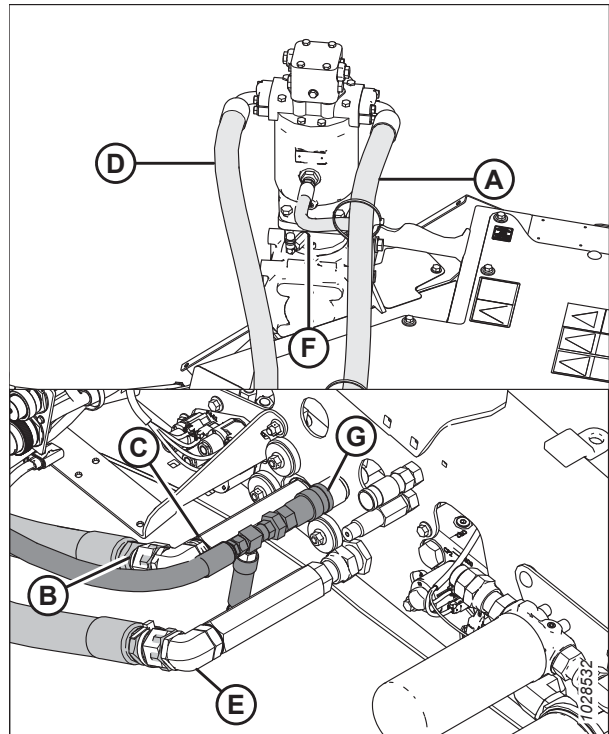

Figure 5.116: Hard-Plumbed Connections on R216 Rotary Disc Header Ready Windrower

ATTACHING ROTARY DISC HEADER TO WINDROWER

4. **Grass seed headers (GSS):** Connect the additional four hoses supplied with the grass seed version of the header as follows:

- a. Install 45° fitting (A) in port R1. Connect hose (C) (blue cable tie) to fitting (A).

NOTE:

The other end of hose (C) connects to the grass seed module's drum on the right side of the header.

- b. Install 45° fitting (B) in port CP2. Connect hose (D) (red cable tie) to fitting (B).

NOTE:

The other end of hose (D) connects to the grass seed module's drum on the left side of the header.

- c. Connect hose (green cable tie) with female quick coupler (E) to coupler (F) as shown.
- d. Connect hose (yellow cable tie) with male quick coupler (G) to coupler (H) as shown.

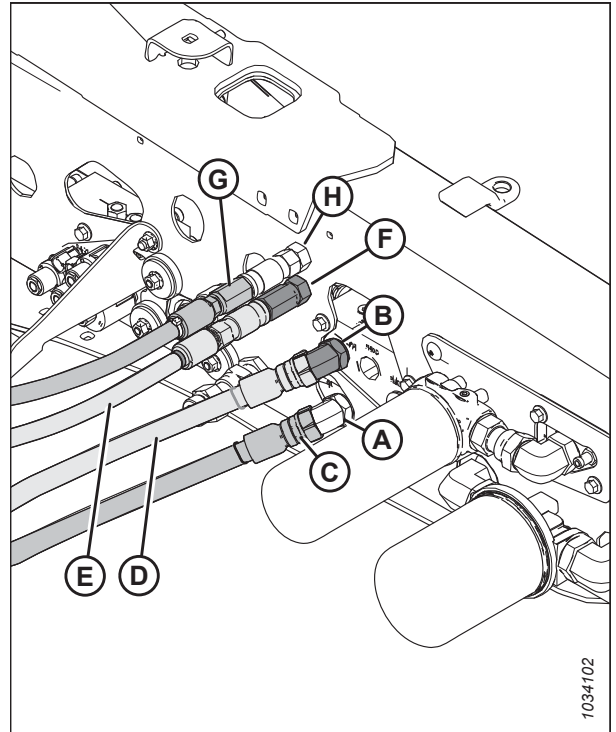

Figure 5.117: Grass Seed Hydraulic Connections – Rotary Disc Configuration

5. Free electrical harness (A) from adjustable strap (B).

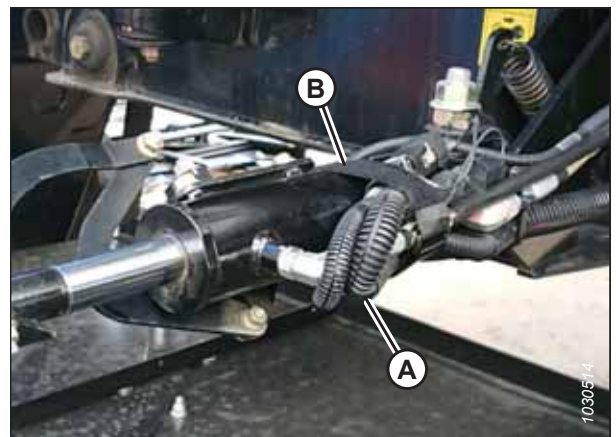

Figure 5.118: Electrical Harness Secured to Center-Link

ATTACHING ROTARY DISC HEADER TO WINDROWER

6. Connect main header harness (A) to adapter harness (B).
7. **Headers equipped with the electric baffle control kit:** Connect electric baffle control harness (C) to adapter harness (D).
8. **Grass seed headers (GSS):** Connect actuator harness (C) to adapter harness (D).

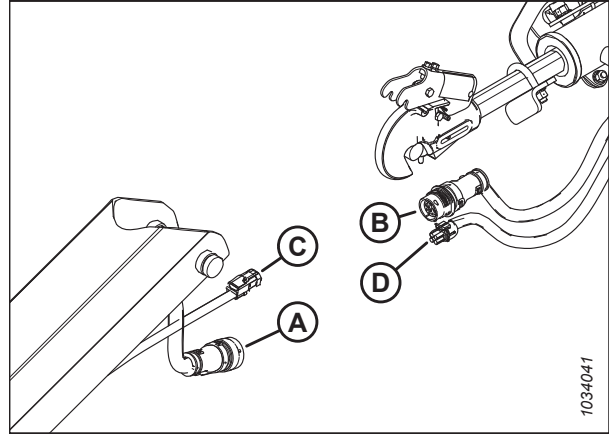

Figure 5.119: Electrical Harness Connection at Center-Link

9. Push latch (A) to unlock platform (B).

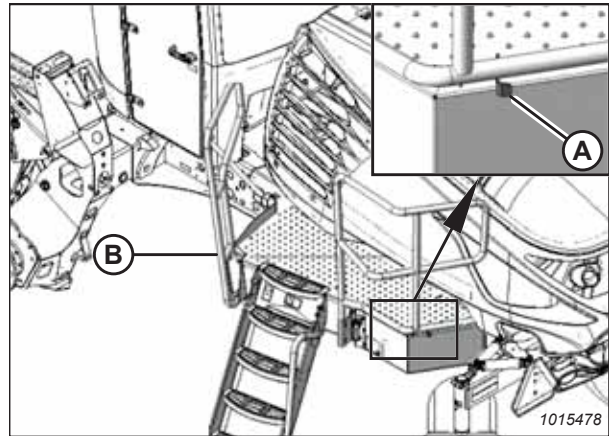

Figure 5.120: Left Platform

10. Pull platform (A) toward the cab until it stops and the latch is engaged.

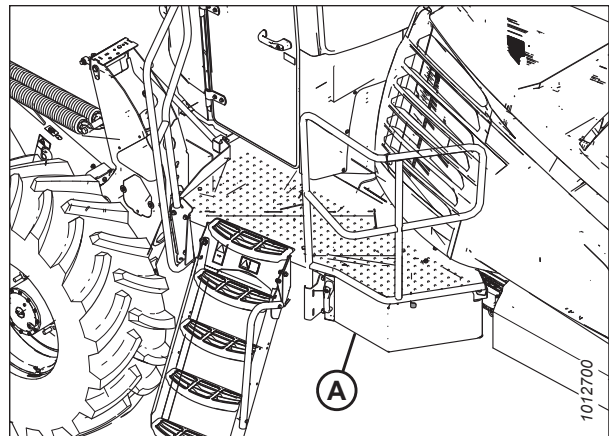

Figure 5.121: Left Platform

⚠ DANGER

Ensure that all bystanders have cleared the area.

11. Start the engine.
12. Extend center-link (A) fully. Ensure that there is some slack in harness (B).
13. Retract center-link (A) fully. Ensure that there is not an excessive amount of harness (B) hanging down.
14. Shut down the engine, and remove the key from the ignition.
15. Adjust harness (B) as needed.
16. Tighten all the cables along the harness.
17. If necessary, calibrate the knife drive. Calibrate the knife drive whenever you are:
 - Attaching the header to the windrower for the first time
 - Changing the speed sensor or hydraulic drive motor on the header
 - Changing the header drive pump associated with the knife drive, Harvest Performance Tracker (HPT), or the master controller on the windrower

For instructions on calibrating the knife drive, refer to [5.6 Calibrating Knife Drive on Harvest Performance Tracker Display – M1 Series Windrowers](#), page 97.

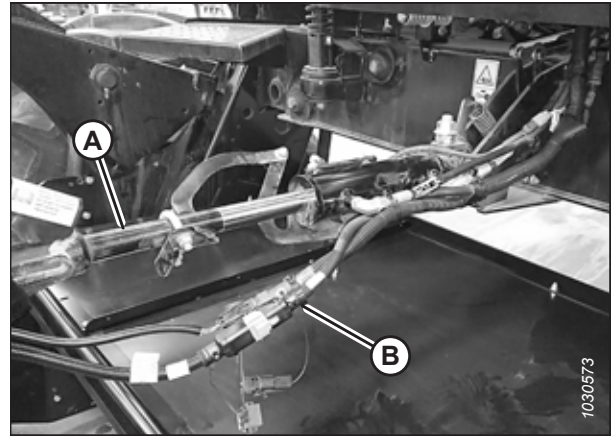

Figure 5.122: Electrical Connection

Rotary Disc-Only Configuration – Quick Coupler Connections

The rotary disc-only configuration allows the windrower to operate with compatible rotary disc headers. Attaching the header’s hydraulic connections to the windrower’s ports using quick couplers does not require any additional tools or hardware.

IMPORTANT:

To protect the hydraulic system from contamination, use a clean rag to remove dirt and moisture from all hydraulic couplers.

1. Retrieve hydraulic hoses (A) from the header and route the hose bundle under the windrower frame.

NOTE:

Adding anti-seize compound to the hose holder pin will make future removal easier.

2. Insert pin (B) into hole (C) in the windrower frame.

IMPORTANT:

Route the hydraulic hoses as straight as possible, avoiding wear points that could damage the hoses. To prevent abrasion damage, the hoses should have enough slack to pass by the multicoupler bracket without contacting it. To adjust the slack in the hoses, loosen the clamps below pin (B), adjust the hoses, then retighten the hose holder.

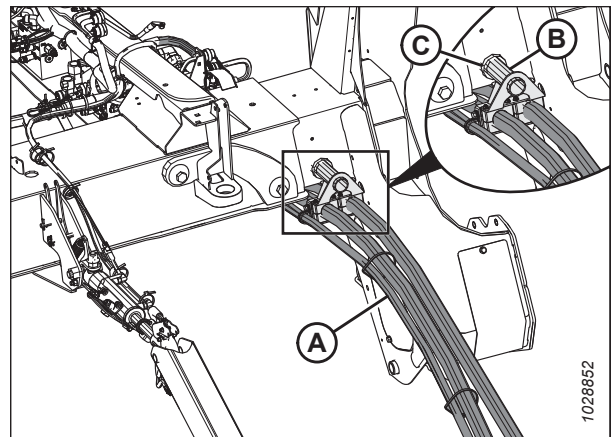

Figure 5.123: Hose Support Attachment

ATTACHING ROTARY DISC HEADER TO WINDROWER

3. Connect the hydraulic fittings to the hydraulic hoses as follows:

NOTE:

Two quick couplers and two elbow fittings are supplied in the Quick Coupler kit (MD #B6277).

- a. Attach 90° elbow fitting (A) and 1 in. female coupler fitting (B) to disc pressure hose (C).
- b. Attach 90° elbow fitting (A) and 1 in. male coupler fitting (D) to disc return hose (E).

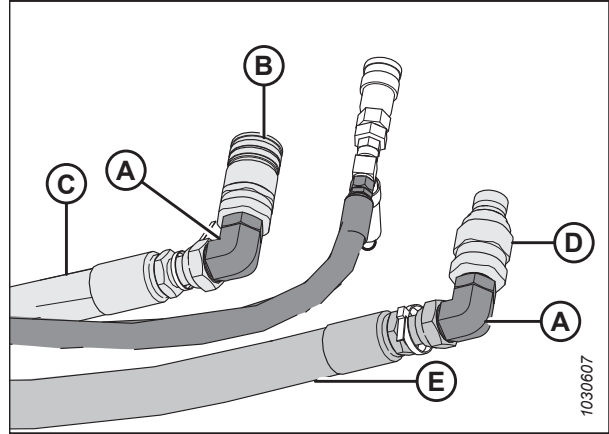

Figure 5.124: Header Hydraulic Fittings

4. Connect the header's hydraulic hoses to the windrower as follows:

- a. Connect disc pressure hose (A) to coupler (B) as shown.
- b. Connect disc return hose (C) to coupler (D) as shown.
- c. Connect case drain hose (E) to fitting (F), ensuring that the connection is oriented so that the relief valve points toward the ground.

NOTE:

Loosen and retighten fitting (F) as needed to ensure that the relief valve is pointing straight down as shown.

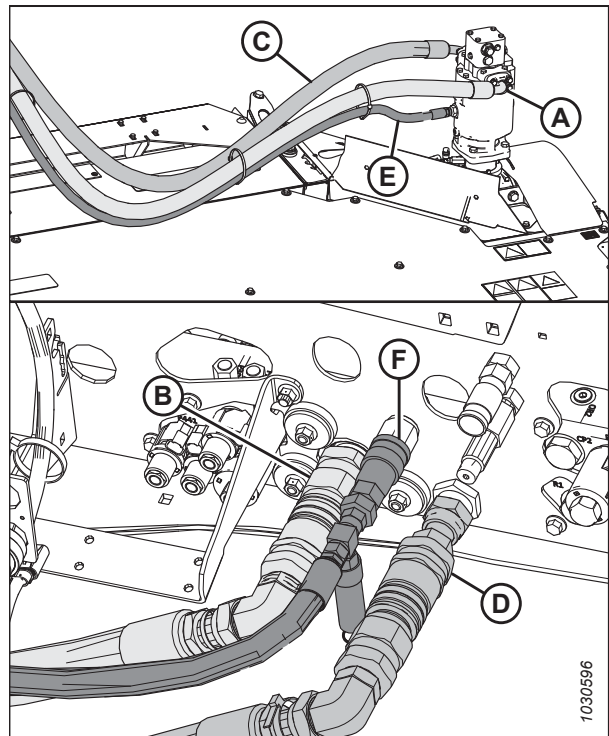

Figure 5.125: Hydraulics and Electrical – Rotary Disc Configuration with Quick Couplers Installed

ATTACHING ROTARY DISC HEADER TO WINDROWER

5. **Grass seed headers (GSS):** Connect the additional four hoses supplied with the grass seed version of the header as follows:

- a. Install 45° fitting (A) in port R1. Connect hose (C) (blue cable tie) to fitting (A).

NOTE:

The other end of hose (C) connects to the grass seed module's drum on the right side of the header.

- b. Install 45° fitting (B) in port CP2. Connect hose (D) (red cable tie) to fitting (B).

NOTE:

The other end of hose (D) connects to the grass seed module's drum on the left side of the header.

- c. Connect the hose (green cable tie) with female quick coupler (E) to coupler (F) on the windrower.
- d. Connect the hose (yellow cable tie) with male quick coupler (G) to coupler (H) on the windrower.

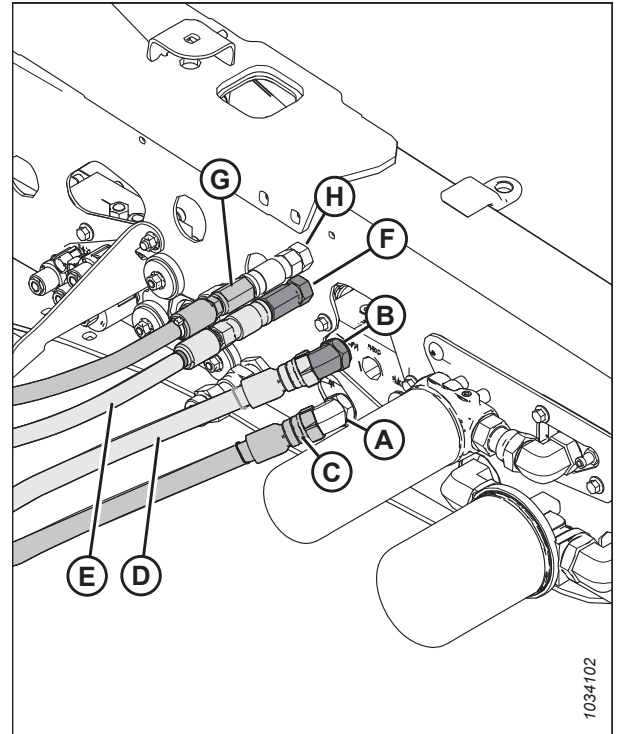

Figure 5.126: Grass Seed Hydraulic Connections – Rotary Disc Configuration

6. Push latch (A) to unlock platform (B).

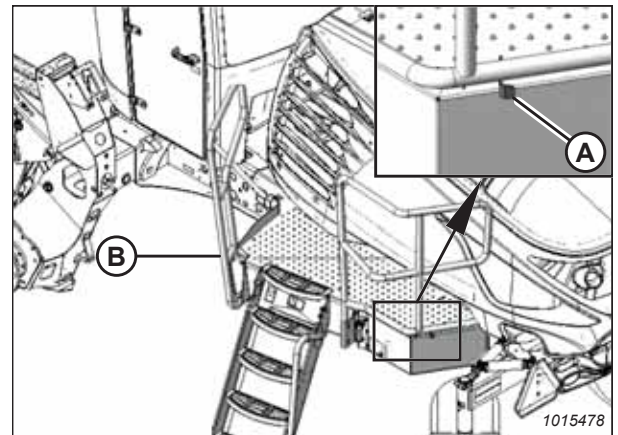

Figure 5.127: Left Platform

ATTACHING ROTARY DISC HEADER TO WINDROWER

7. Pull platform (A) toward the cab until it stops and the latch is engaged.

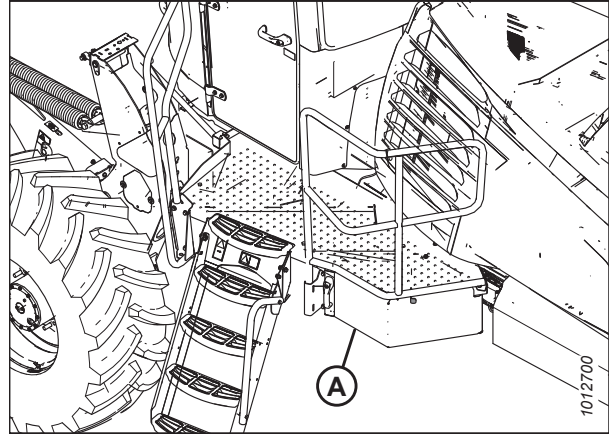

Figure 5.128: Left Platform

DANGER

Ensure that all bystanders have cleared the area.

8. Start the engine.
9. Extend center-link (A) fully. Ensure that there is some slack in harness (B).
10. Retract center-link (A) fully. Ensure that there is not an excessive amount of harness (B) hanging down.
11. Shut down the engine, and remove the key from the ignition.
12. Adjust harness (B) as needed.
13. Tighten all the cables along the harness.
14. If necessary, calibrate the knife drive. Calibrate the knife drive whenever you are:
 - Attaching the header to the windrower for the first time
 - Changing the speed sensor or hydraulic drive motor on the header
 - Changing the header drive pump associated with the knife drive, Harvest Performance Tracker (HPT), or the master controller on the windrower

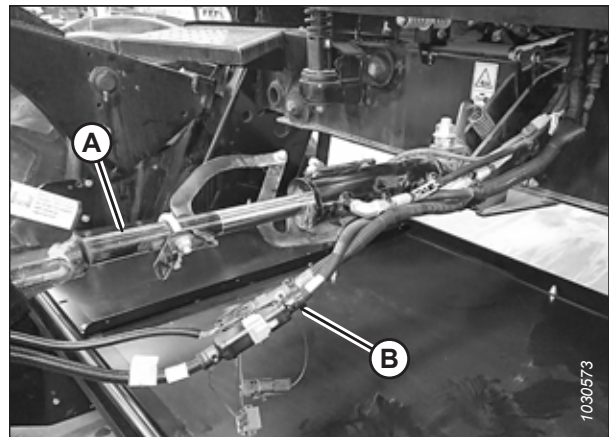

Figure 5.129: Electrical Connection

For instructions on calibrating the knife drive, refer to [5.6 Calibrating Knife Drive on Harvest Performance Tracker Display – M1 Series Windrowers, page 97](#).

5.6 Calibrating Knife Drive on Harvest Performance Tracker Display – M1 Series Windrowers

When a header is attached to the windrower, the windrower’s Harvest Performance Tracker (HPT) will recognize the header ID and choose the appropriate settings for that header. Before it can be operated however, the header’s knife drive must be calibrated to ensure that the knife drive pump output is accurate.

DANGER

Ensure that all bystanders have cleared the area.

1. Start the engine.
2. Press soft key 5 (A) to open the Harvest Performance Tracker (HPT) HPT main menu.

NOTE:

Calibrations **MUST** be performed with the engine running. Some calibrations will not be available with the engine off.

3. Use HPT scroll knob (B) or the ground speed lever (GSL) scroll wheel (not shown) to highlight SETTINGS icon (C).
4. Press HPT scroll knob (B) or the GSL SELECT button (not shown) to activate the settings menu options.

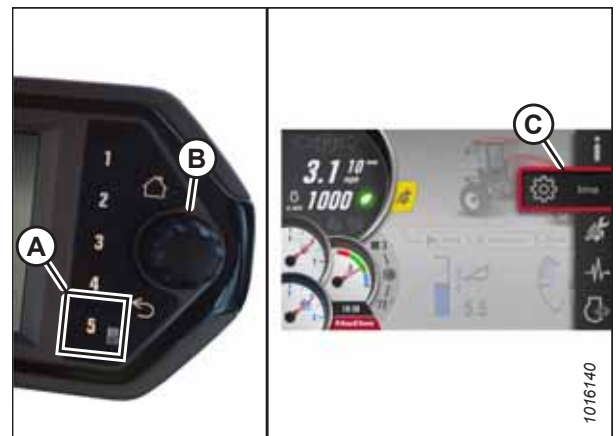

Figure 5.130: Opening the Main Menu

5. Scroll to WINDROWER icon (A) and press the HPT scroll knob.
6. Scroll to CALIBRATION icon (B), and press SELECT to open the CALIBRATION SELECTION page.

NOTE:

The F3 shortcut button on the operator’s console will also open the WINDROWER SETTINGS menu.

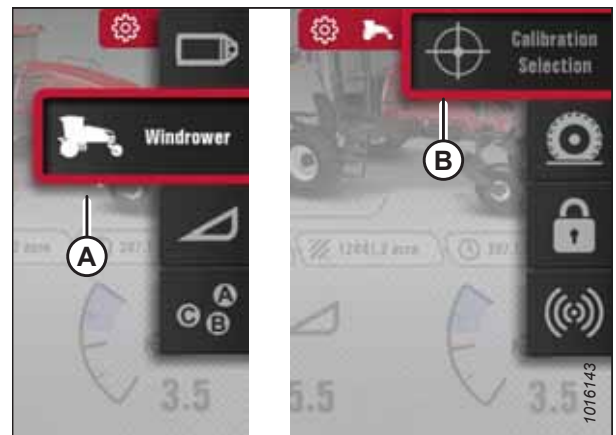

Figure 5.131: Windrower Icon and Calibration Selection Submenu Icon

ATTACHING ROTARY DISC HEADER TO WINDROWER

7. On the CALIBRATION SELECTION page, scroll to KNIFE DRIVE (A) and press SELECT.
8. Engage the header.

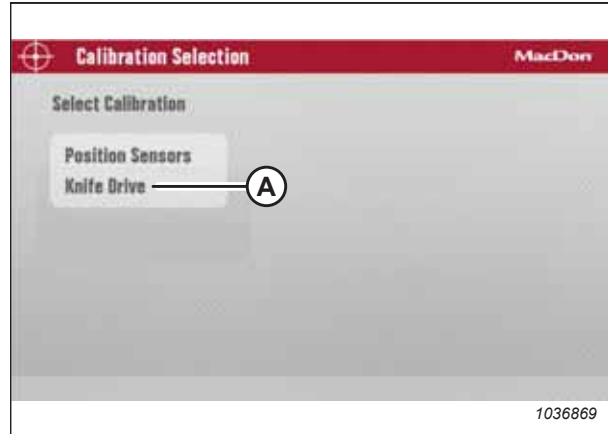

Figure 5.132: Calibration Selection Page

NOTE:

If calibration is selected while the header is disengaged, WARNING (A) will appear. PLAY icon (B) appears after the header is engaged.

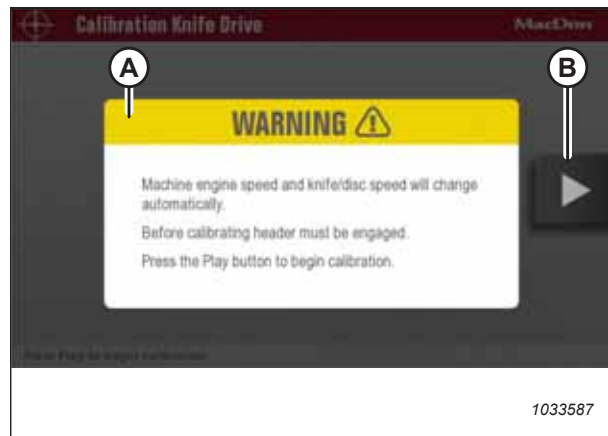

Figure 5.133: Engage Header Warning

9. Press the PLAY icon to begin calibration. The display changes to show that calibration has started.

NOTE:

If the engine speed is less than 1500 rpm prior to starting calibration, the system will raise the engine speed to 1500 rpm.



Figure 5.134: Calibration Page

ATTACHING ROTARY DISC HEADER TO WINDROWER

10. When Stage 1 of calibration is complete, press PLAY icon (A) to continue with Stage 2.

NOTE:

The knife drive calibration process consists of nine stages.



Figure 5.135: Calibration Page

11. Press the PLAY icon to begin the calibration process.

NOTE:

During the calibration process, the speed of the header and the engine will fluctuate.

NOTE:

Press X icon (A) or use the HEADER DISENGAGE switch at any time during calibration to cancel the process without saving your progress. The engine will resume the speed at which it was operating before calibration began.



Figure 5.136: Calibration Page

NOTE:

If error message (A) appears during the calibration process, follow the instructions in the message to fix the error. Press X (B) to exit the message. If the knife calibration process fails:

- Confirm that the engine and the hydraulics are at operating temperature.
- Confirm that the hydraulic system is free of any restrictions and that it is in working order.
- Confirm that the throttle is working:
 - Check the engine codes to confirm that the engine is not derated or throttle-inhibited.
 - The throttle is controlled via the powertrain's CAN network 1. Check the network's wiring and connectors for an open or intermittent connection.
- Confirm that the sensor mounting is secured properly and that the sensor's gap is set correctly.
- Check the sensor wiring and connectors for an intermittent connection.
- Replace the sensor.

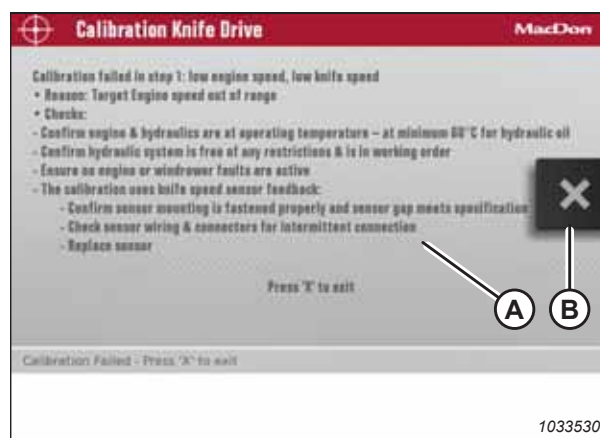

Figure 5.137: Calibration Page

5.7 Calibrating Header Position Sensors on Harvest Performance Tracker Display – M1 Series Windrowers

The header position sensors need to be recalibrated whenever the Harvest Performance Tracker (HPT) is replaced, a position sensor is replaced, sensor readouts are erratic, a pump has been replaced, or when a new header type or attachment is connected to the windrower.

DANGER

Ensure that all bystanders have cleared the area.

1. Start the engine.
2. Press soft key 5 (A) to open the Harvest Performance Tracker (HPT) HPT main menu.

NOTE:

Calibrations **MUST** be performed with the engine running. Some calibrations will not be available with the engine off.

3. Use HPT scroll knob (B) or the ground speed lever (GSL) scroll wheel (not shown) to highlight SETTINGS icon (C).
4. Press HPT scroll knob (B) or the GSL SELECT button (not shown) to activate the settings menu options.

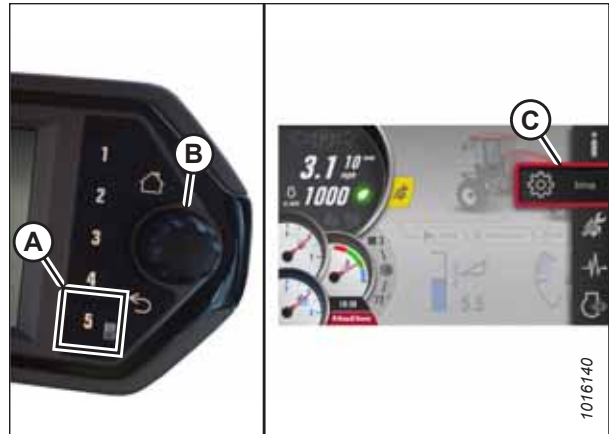

Figure 5.138: Opening the Main Menu

5. Scroll to WINDROWER icon (A) and press the HPT scroll knob.
6. Scroll to CALIBRATION icon (B), and press SELECT to open the CALIBRATION SELECTION page.

NOTE:

The F3 shortcut button on the operator's console will also open the WINDROWER SETTINGS menu.

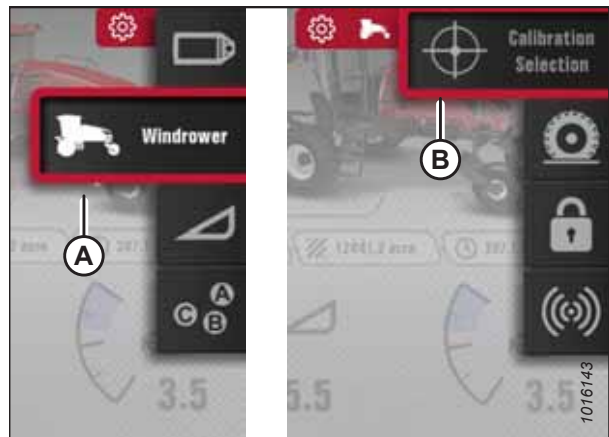

Figure 5.139: Windrower Icon and Calibration Selection Submenu Icon

ATTACHING ROTARY DISC HEADER TO WINDROWER

7. On the CALIBRATION SELECTION page, scroll to POSITION SENSORS (A) and press SELECT.

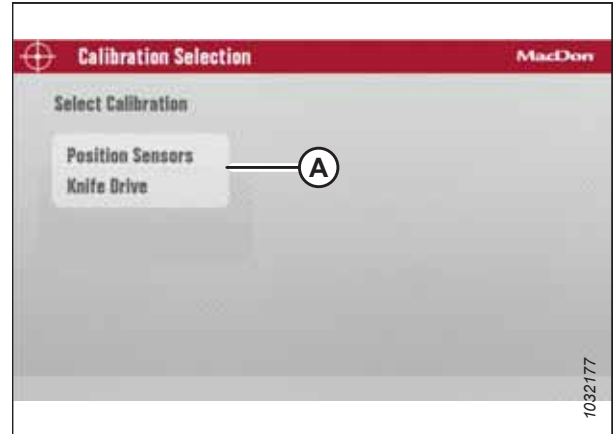

Figure 5.140: Calibration Selection Page

NOTE:

Pressing X icon (A) (or pressing the HOME, BACK or any GSL button [buttons not shown]) at any time during the calibration process will EXIT the calibration procedure without saving your progress. The engine speed will also return to the original rpm prior to starting the calibration process.

NOTE:

If a sensor goes out of its normal operating range during the calibration process, calibration will stop and a message appears on the screen indicating that a sensor is out of range.



Figure 5.141: Calibration Page

8. When stage one of calibration is complete, press PLAY icon (A) to continue with stage two of the calibration process.



Figure 5.142: Calibration Page

ATTACHING ROTARY DISC HEADER TO WINDROWER

- When stage two of calibration is complete, press RESUME icon (A) to configure the HEADER FLOAT setting, or press HOME or BACK button (not shown) to exit the page.

NOTE:

The engine speed returns to the speed prior to calibration when stage two calibration is complete.



Figure 5.143: Calibration Page

NOTE:

If the voltage of any sensor falls below its acceptable range during calibration, a message appears after completing calibration with a list of sensors reporting out-of-range voltages. Adjust the sensors as needed and repeat the calibration process from the beginning.

- Proceed to Chapter 6 *Unpacking the Curtain*, page 151.



Figure 5.144: Sample of Failed Calibration Display Message

5.8 Attaching R2 Series Rotary Disc Header to M205 SP Windrower

Attaching the header to the windrower will allow you to cut, condition, and lay a wide variety of grasses and hay crops in windrows.

IMPORTANT:

The M205 Completion Kit (B7220) must be installed on the header before you can attach it to the M205 SP Windrower.

5.8.1 Attaching R2 Series Rotary Disc Header to M205 SP Windrower – Hydraulic Center-Link with Optional Self-Alignment

The optional self-aligning hydraulic center-link on an M205 SP Windrower allows vertical position control of the center-link from the cab.

DANGER

To prevent bodily injury or death from the unexpected startup of the machine, always stop the engine and remove the key from the ignition before leaving the operator's seat for any reason.

NOTE:

The R216 Rotary Disc Header requires conversion kit (B7220) if it is being used with an M205 SP Windrower. Once the header is configured for an M205 SP Windrower, the R216 Rotary Disc Header is incompatible with the optional Remote Baffle Control kit (B6664).

1. Shut down the engine, and remove the key from the ignition.
2. Remove hairpin (A) from clevis pin (B), and remove the pin from header support (C) on both sides of the header.

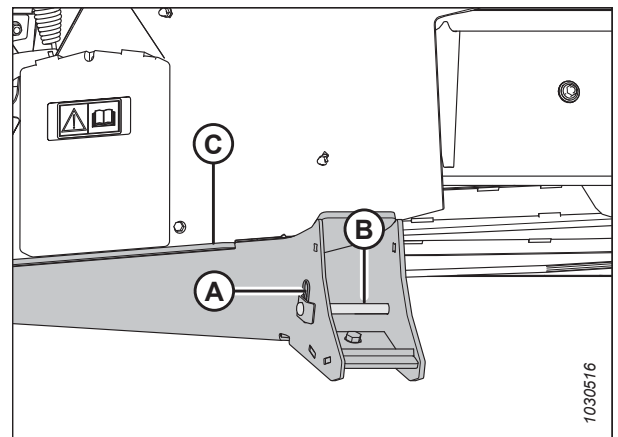

Figure 5.145: Header Support

ATTACHING ROTARY DISC HEADER TO WINDROWER

3. Lift header support (A) and place 2 x 4 in. blocks (B) under the header support. A total of four 2 x 4 in. blocks (B) will be necessary to raise the boot up into field position. Ensure the boot's bottom edge (C) is parallel with the ground. Repeat this step for the opposite side.

NOTE:

Do **NOT** stack blocks (B) crosswise as doing so can make the header unstable when attempting to connect the header and windrower. Stack blocks (B) parallel with each other.

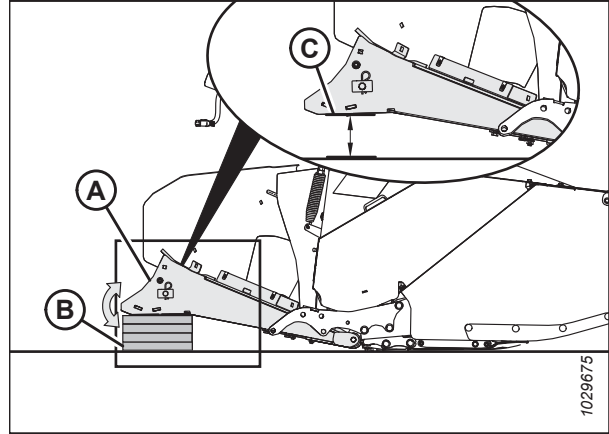

Figure 5.146: Header Support

4. Remove the float engagement pin from hole (A) to disengage the float springs, and insert the float engagement pin into storage hole (B). Secure the float engagement pin with a lynch pin. Repeat this step for the opposite linkage.

IMPORTANT:

To prevent damage to the lift system when lowering the header lift linkages without a header or weight box attached to the windrower, ensure that the float engagement pin is installed in storage hole (B) and **NOT** in engaged position (A).

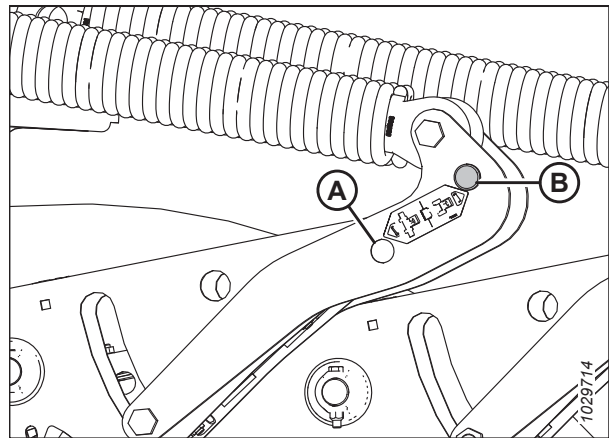

Figure 5.147: Float Linkage

DANGER

Ensure that all bystanders have cleared the area.

5. Start the engine and activate HEADER DOWN button (A) on the ground speed lever (GSL) to fully retract the header lift cylinders.

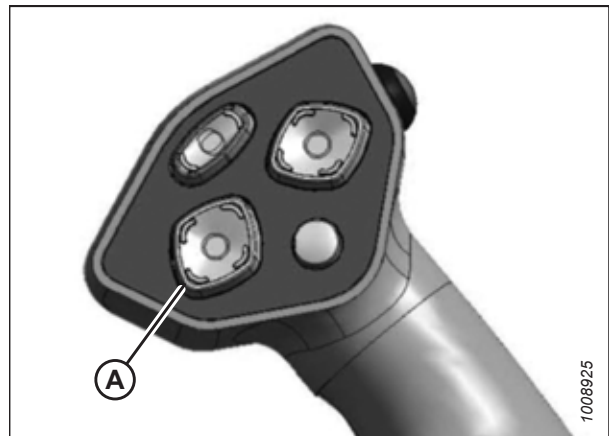

Figure 5.148: Ground Speed Lever

ATTACHING ROTARY DISC HEADER TO WINDROWER

6. Press REEL UP switch (A) on the GSL to raise the center-link until the hook is above the attachment pin on the header.

IMPORTANT:

If the center-link is too low, it may contact the header as the windrower approaches the header for hookup.

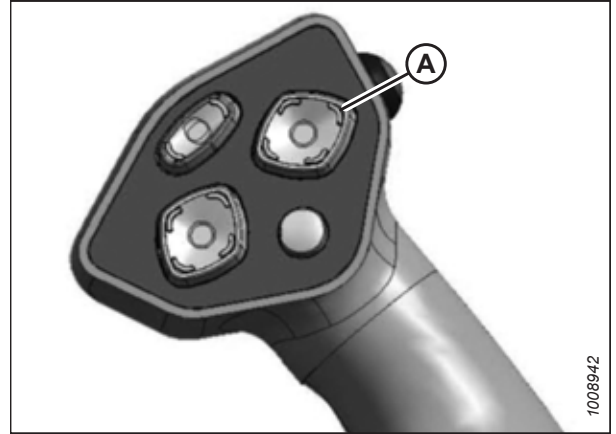

Figure 5.149: Ground Speed Lever

7. Slowly drive the windrower forward until windrower feet (A) enter header supports (B). Continue driving slowly forward until the feet engage the supports and the header nudges forward.

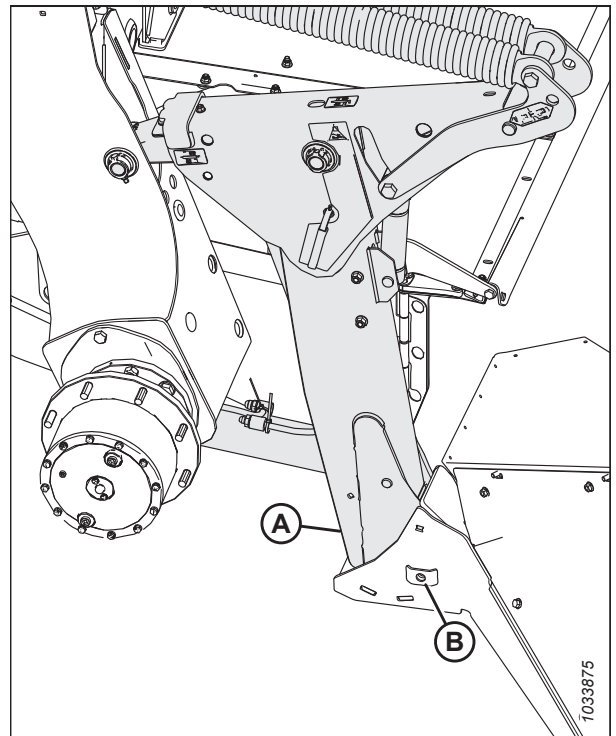

Figure 5.150: Header Support

ATTACHING ROTARY DISC HEADER TO WINDROWER

8. Use the following GSL functions to position the center-link hook above the header attachment pin:

- REEL UP (A) to raise the center-link
- REEL DOWN (B) to lower the center-link
- HEADER TILT UP (C) to retract the center-link
- HEADER TILT DOWN (D) to extend the center-link

IMPORTANT:

The hook release must be down to enable the self-locking mechanism. If the release is open (up), manually push it down after the hook engages the header pin.

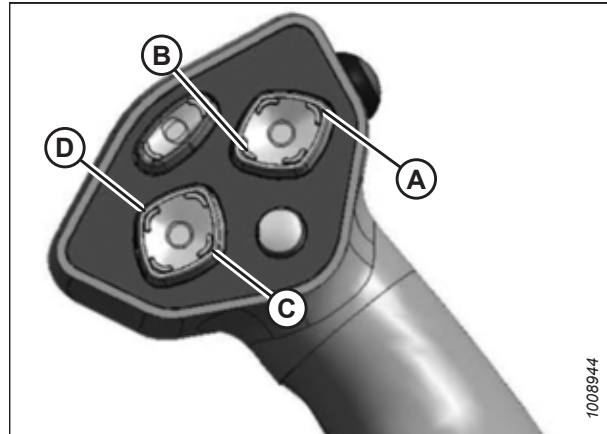

Figure 5.151: Ground Speed Lever

9. Adjust the position of center-link cylinder (A) with the REEL UP and REEL DOWN switches on the GSL until the hook is positioned above the header attachment pin.

IMPORTANT:

Hook release (B) must be down to enable the self-locking mechanism. If the release is open (up), manually push it down after the hook engages the header pin.

10. Lower center-link (A) onto the header using the REEL DOWN switch on the GSL until the center-link locks into position and hook release (B) is down.
11. Check that the center-link is locked onto the header by pressing the REEL UP switch on the GSL.

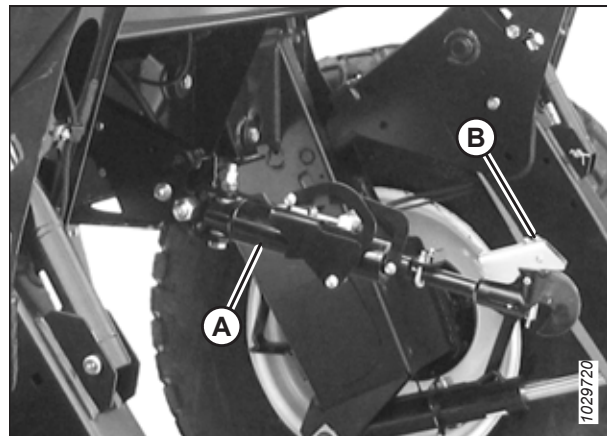

Figure 5.152: Hydraulic Center-Link

12. Press HEADER UP switch (A) to raise the header to its maximum height.
13. If one end of the header does **NOT** fully rise, rephase the lift cylinders as follows:
- a. Press and hold the HEADER UP switch until both cylinders stop moving.
 - b. Continue to hold the switch for 3–4 seconds to fully phase the cylinders.

NOTE:

It may be necessary to repeat this procedure if there is air in the hydraulic system.



Figure 5.153: Ground Speed Lever

ATTACHING ROTARY DISC HEADER TO WINDROWER

14. To lower the safety props:
 - a. Pull lever (A) outward and rotate it towards the header to release and lower safety prop (B) onto the lift cylinder.
 - b. Repeat the previous step for the opposite lift cylinder.
 - c. Shut down the engine, and remove the key from the ignition.

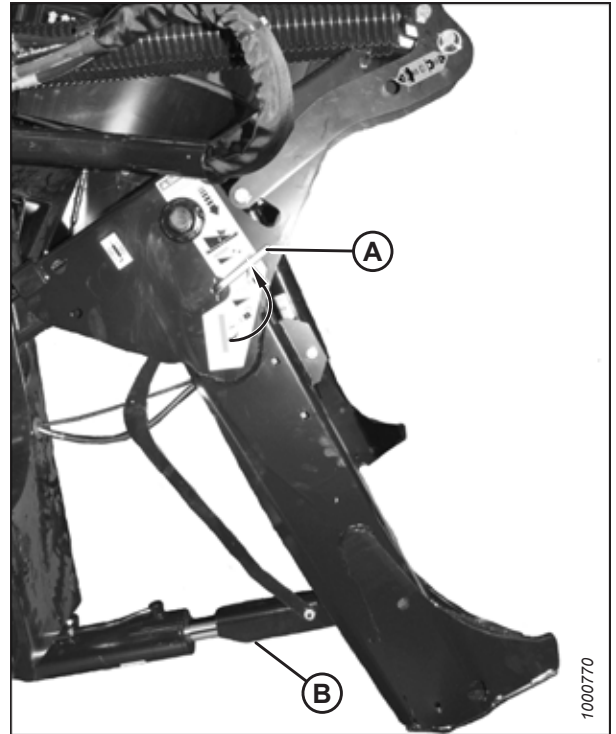

Figure 5.154: Safety Prop

15. Install clevis pin (A) through the support and the windrower lift member, and secure it with hairpin (B). Repeat this step for the opposite side of the machine.

IMPORTANT:

Ensure clevis pin (A) is fully inserted and the hairpin is installed behind the bracket.

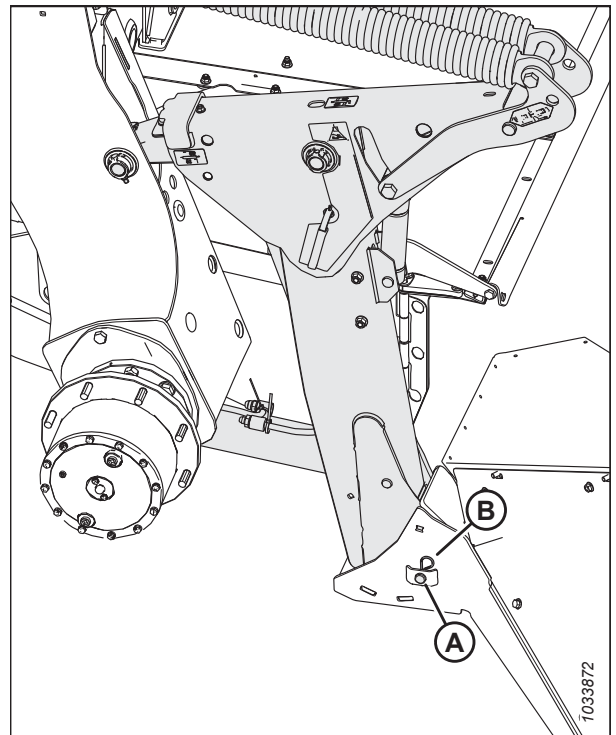

Figure 5.155: Header Support

ATTACHING ROTARY DISC HEADER TO WINDROWER

16. Remove the clevis pin from storage position (B) in the linkage and insert it into hole (A) to engage the float springs. Secure it with the hairpin. Repeat this step on the opposite float linkage.

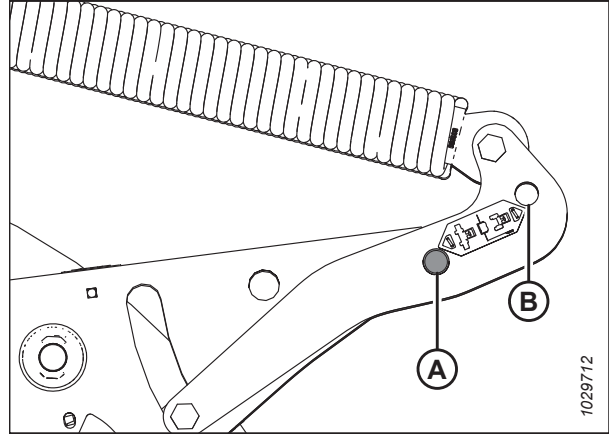

Figure 5.156: Header Float Linkage

17. Disengage the safety prop by turning lever (A) downwards until the lever locks into vertical position.
18. Repeat the previous step to disengage the other safety prop.

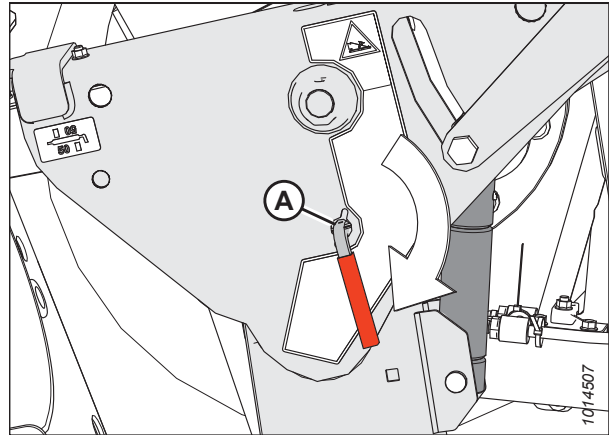

Figure 5.157: Safety Prop

19. Start the engine, and press HEADER DOWN switch (A) on the GSL to fully lower the header.
20. Shut down the engine, and remove the key from the ignition.
21. Proceed to [5.8.3 Connecting R2 Series Rotary Disc Header Hydraulics and Electrical Components – M205 SP Windrower, page 115](#).

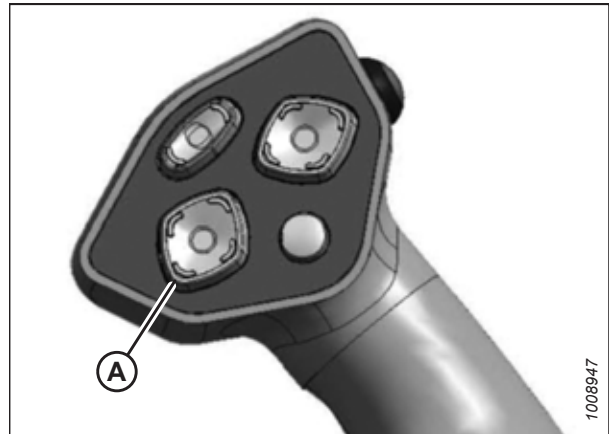

Figure 5.158: Ground Speed Lever

5.8.2 Attaching R2 Series Rotary Disc Header to M205 SP Windrower – Hydraulic Center-Link without Optional Self-Alignment

Attach the header to an M205 SP Windrower that is equipped without an optional self-aligning hydraulic center-link (which allows the operator to control the vertical position of the center-link from the cab).

DANGER

To prevent bodily injury or death from the unexpected startup of the machine, always stop the engine and remove the key from the ignition before leaving the operator's seat for any reason.

1. Shut down the engine, and remove the key from the ignition.
2. Remove hairpin (A) from clevis pin (B), and remove the pin from header support (C) on both sides of the header.

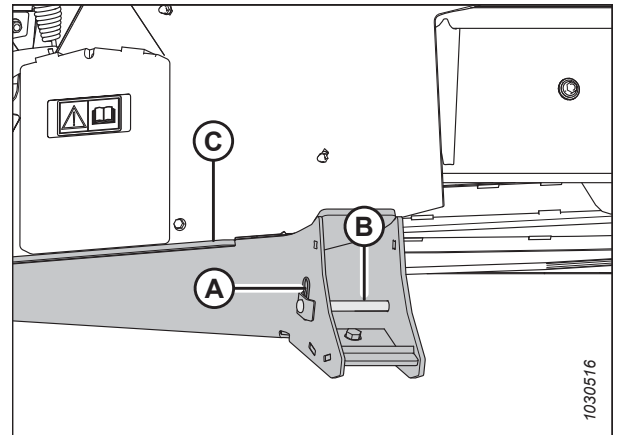

Figure 5.159: Header Support

3. Lift header support (A) and place 2 x 4 in. blocks (B) under the header support. A total of four 2 x 4 in. blocks (B) will be necessary to raise the boot up into field position. Ensure the boot's bottom edge (C) is parallel with the ground. Repeat this step for the opposite side.

NOTE:

Do **NOT** stack blocks (B) crosswise as doing so can make the header unstable when attempting to connect the header and windrower. Stack blocks (B) parallel with each other.

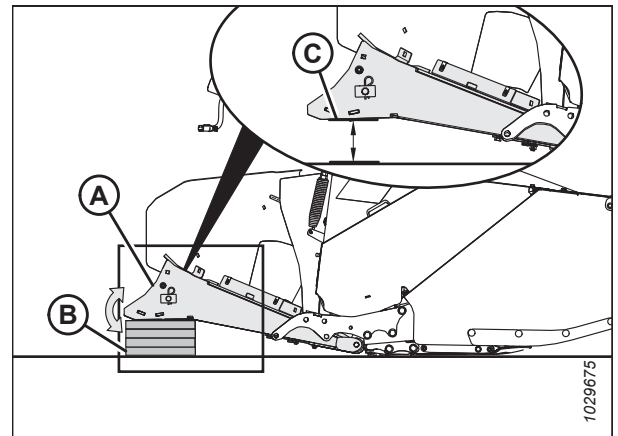

Figure 5.160: Header Support

ATTACHING ROTARY DISC HEADER TO WINDROWER

- To disengage the float springs, move the float engagement pin from engaged position (A) and insert the pin into storage hole (B). Secure the float engagement pin with a lynch pin. Repeat this step for the opposite linkage.

IMPORTANT:

To avoid damaging the lift system when lowering the header lift linkages without a header or weight box attached, ensure the float engagement pin is installed in storage position (B) and **NOT** in engaged position (A).

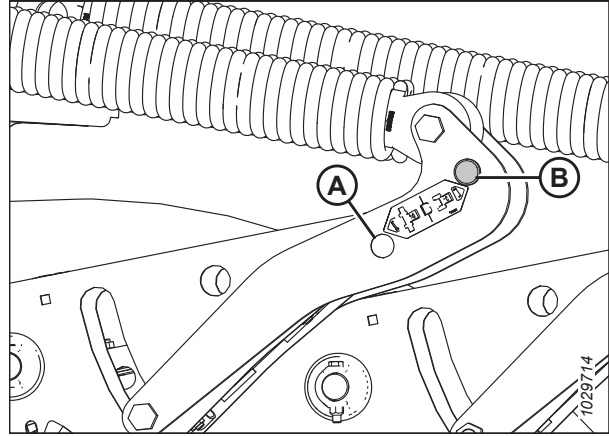

Figure 5.161: Header Float Linkage

DANGER

Ensure that all bystanders have cleared the area.

- Start the engine and activate HEADER DOWN button (A) on the ground speed lever (GSL) to fully retract the header lift cylinders.

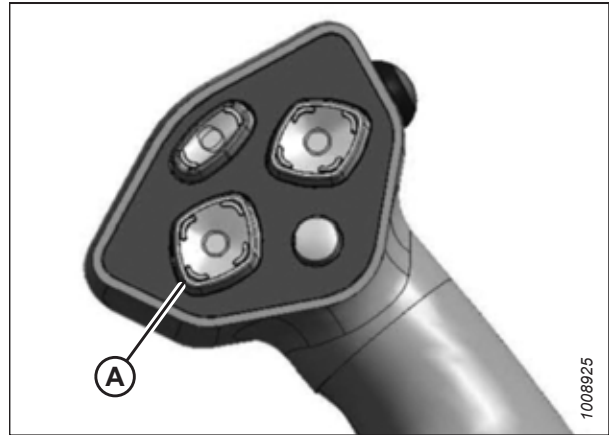

Figure 5.162: Ground Speed Lever

- Remove pin (A) from the frame linkage and raise center-link (B) until the hook is above the attachment pin on the header. Replace pin (A) to hold the center-link in place.

IMPORTANT:

If the center-link is too low, it may contact the header as the windrower approaches the header for hookup.

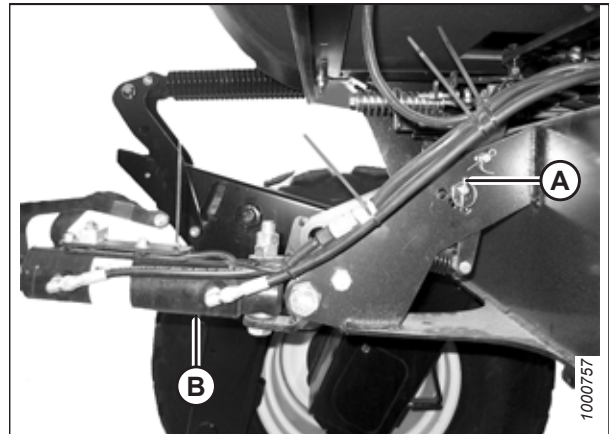

Figure 5.163: Hydraulic Center-Link

ATTACHING ROTARY DISC HEADER TO WINDROWER

7. Slowly drive the windrower forward until windrower feet (A) enter header supports (B). Continue driving slowly forward until the feet engage the supports and the header nudges forward.

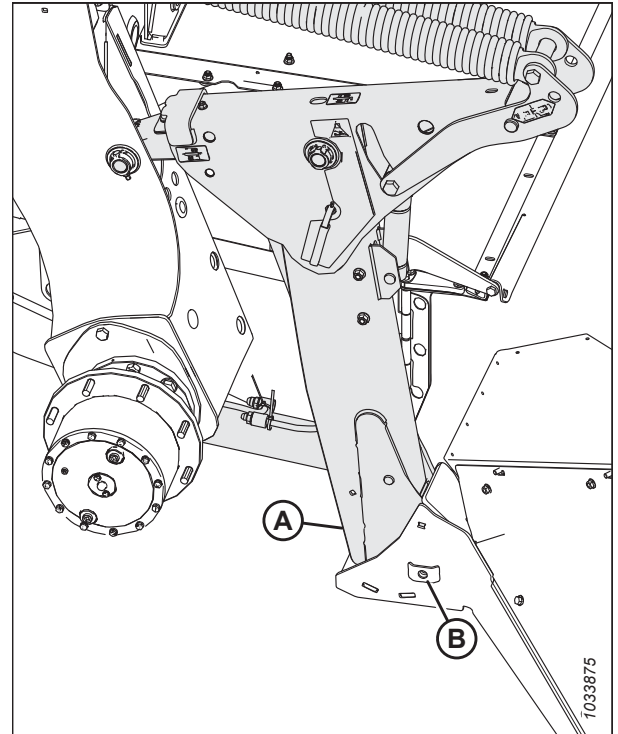

Figure 5.164: Header Support

8. Use the following GSL functions to position the center-link hook above the header attachment pin:
 - HEADER TILT UP (A) to retract the center-link
 - HEADER TILT DOWN (B) to extend the center-link
9. Stop the engine, and remove the key from the ignition.

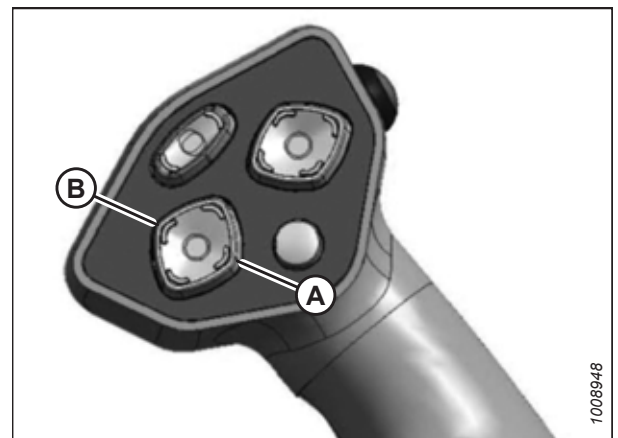

Figure 5.165: Ground Speed Lever

ATTACHING ROTARY DISC HEADER TO WINDROWER

10. Push down on the rod end of link cylinder (A) until hook (B) engages and locks onto the header pin.

IMPORTANT:

The hook release must be down to enable the self-locking mechanism. If the release is open (up), manually push it down after the hook engages the header pin.

11. Check that center-link (A) is locked onto the header by pulling upward on the rod end of the cylinder.

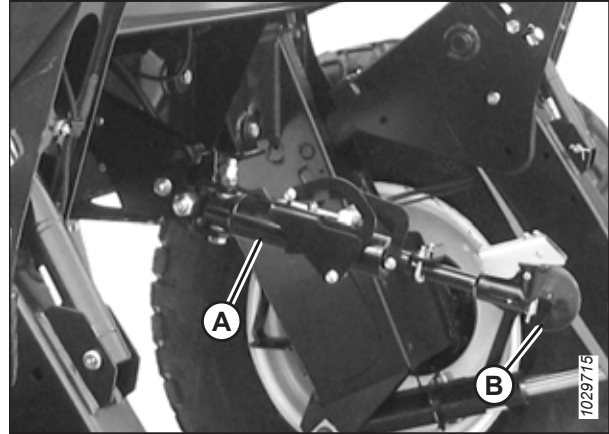

Figure 5.166: Hydraulic Center-Link

DANGER

Ensure that all bystanders have cleared the area.

12. Start the engine.
13. Press HEADER UP switch (A) to raise the header to maximum height.
14. If one end of the header does **NOT** fully raise, rephase the lift cylinders as follows:
 - a. Press and hold the HEADER UP switch until both cylinders stop moving.
 - b. Continue to hold the switch for 3–4 seconds. The cylinders are now phased.

NOTE:

It may be necessary to repeat this procedure if there is air in the system.



Figure 5.167: Ground Speed Lever

ATTACHING ROTARY DISC HEADER TO WINDROWER

15. Pull lever (A) outward and rotate it toward the header to lower safety prop (B) onto the cylinder. Repeat this step for the opposite cylinder.
 - a. Shut down the engine, and remove the key from the ignition.
 - b. Pull lever (A) outward and rotate it towards the header to release and lower safety prop (B) onto the lift cylinder.
 - c. Repeat this step for the opposite lift cylinder.

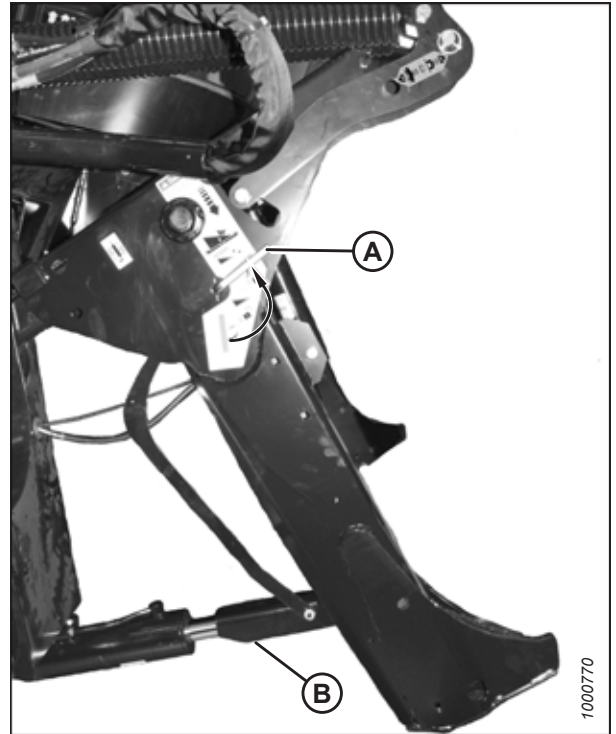

Figure 5.168: Safety Prop

16. Install clevis pin (A) through the support and the windrower lift member, and secure it with hairpin (B). Repeat this step for the opposite side of the machine.

IMPORTANT:

Ensure clevis pin (A) is fully inserted and the hairpin is installed behind the bracket.

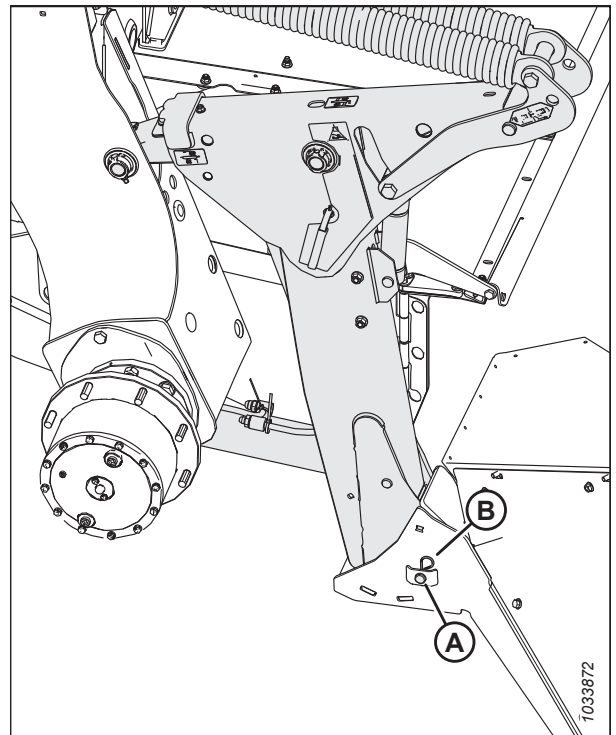

Figure 5.169: Header Support

ATTACHING ROTARY DISC HEADER TO WINDROWER

17. Remove the clevis pin from storage position (B) in the linkage and insert it into hole (A) to engage the float springs. Secure it with the hairpin. Repeat this step on the opposite float linkage.

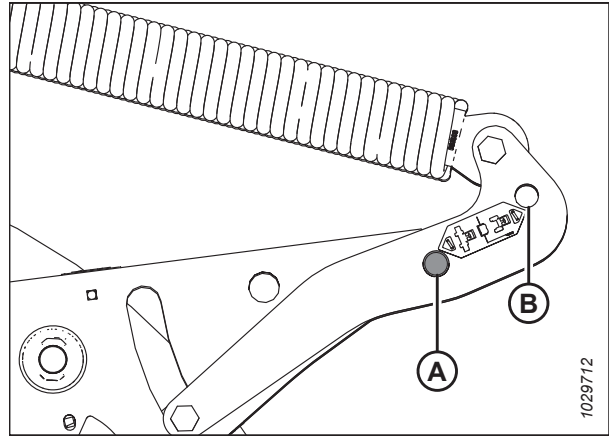

Figure 5.170: Header Float Linkage

18. Disengage the safety prop by turning lever (A) downwards until the lever locks into vertical position.
19. Repeat the previous step to disengage the other safety prop.

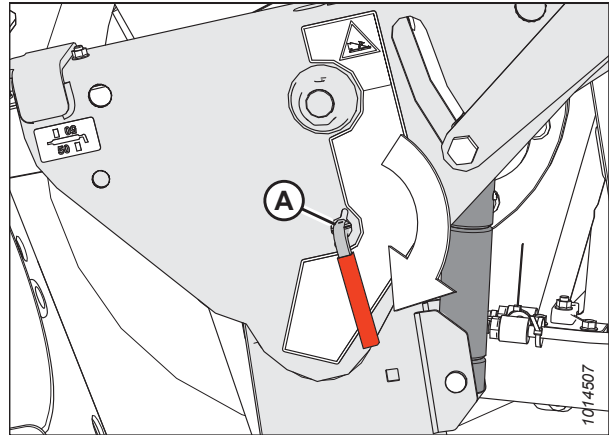

Figure 5.171: Safety Prop

20. Start the engine, and press HEADER DOWN switch (A) on the GSL to fully lower the header.
21. Shut down the engine, and remove the key from the ignition.
22. Proceed to [5.8.3 Connecting R2 Series Rotary Disc Header Hydraulics and Electrical Components – M205 SP Windrower](#), page 115.

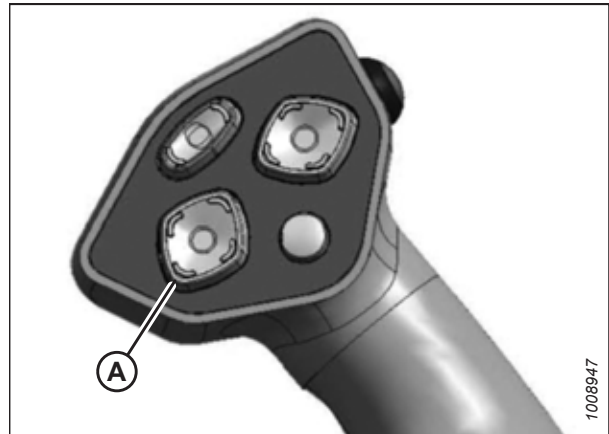

Figure 5.172: Ground Speed Lever

5.8.3 Connecting R2 Series Rotary Disc Header Hydraulics and Electrical Components – M205 SP Windrower

Connect the header hydraulic and electrical components to the windrower in order to operate the header.

DANGER

To prevent bodily injury or death from the unexpected startup of the machine, always stop the engine and remove the key from the ignition before leaving the operator's seat for any reason.

NOTE:

The M205 compatibility kit B7220 is required to connect an R216 Rotary Disc Header to an M205 SP Windrower. This kit supplies the hydraulic fittings used for hard-plumbed connections.

NOTE:

If the M205 SP Windrower uses quick coupler connections, install quick coupler kit (B5497) onto the R216 Rotary Disc Header pressure and return hoses.

1. Shut down the engine, and remove the key from the ignition.
2. Open the left platform. For instructions, refer to the windrower operator's manual.
3. Insert the pin on header hose support (A) into hole (B) in the windrower frame near the left cab-forward leg.

IMPORTANT:

Route the hoses as straight as possible and avoid rub/wear points that could damage the hydraulic hoses.

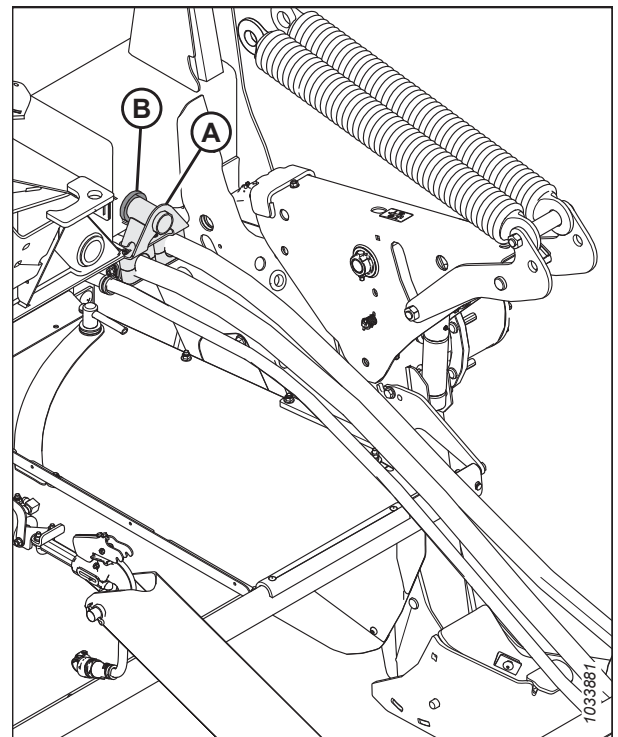

Figure 5.173: Hose Support Installed

ATTACHING ROTARY DISC HEADER TO WINDROWER

NOTE:

When connecting the header hoses to the windrower in the following steps, you can adjust the length of the hoses as follows:

- To adjust the length of the case drain hose, loosen nut (A) and clamp (B).
- To adjust the length of the pressure and return hoses, loosen nuts (C) and clamps (D).

Tighten the hardware after adjusting the length of the hoses.

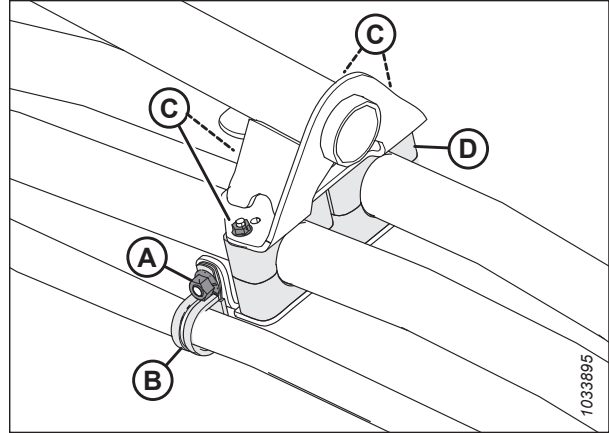

Figure 5.174: Hose Support Clamps

4. Proceed according to the type of hydraulic couplers or fittings used on the M205 SP Windrower:

- If the M205 SP Windrower is equipped with quick couplers (A) to connect to the header, proceed to Step 5, [page 117](#).

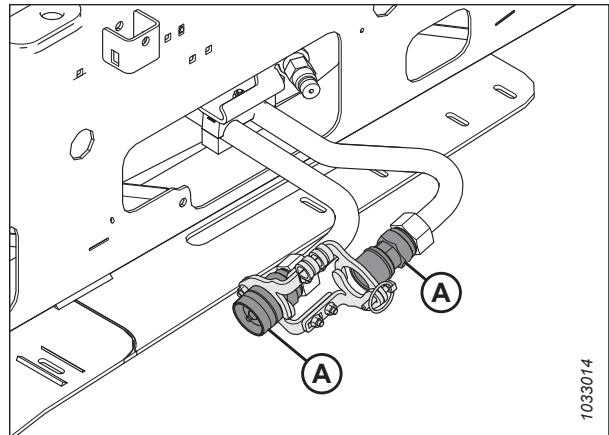

Figure 5.175: Pressure and Return Steel Lines with Quick Couplers

- If the M205 SP Windrower uses union fittings (A) instead of quick couplers to connect to the header, remove union fittings (A) from the steel lines and install the hard-plumbed connections provided in the M205 compatibility kit. For instructions, proceed to Step 13, [page 119](#).

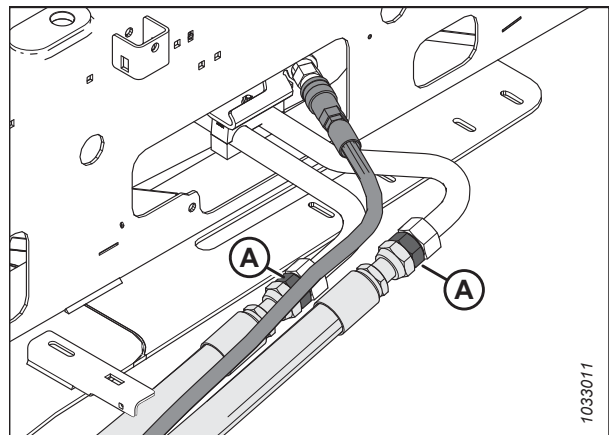

Figure 5.176: Pressure and Return Steel Lines with Union Fittings

ATTACHING ROTARY DISC HEADER TO WINDROWER

- If the M205 SP Windrower has plugs (A) installed in the steel lines, remove the plugs from the steel lines and install the hard-plumbed connections provided in the M205 compatibility kit. For instructions, proceed to Step 13, page 119.

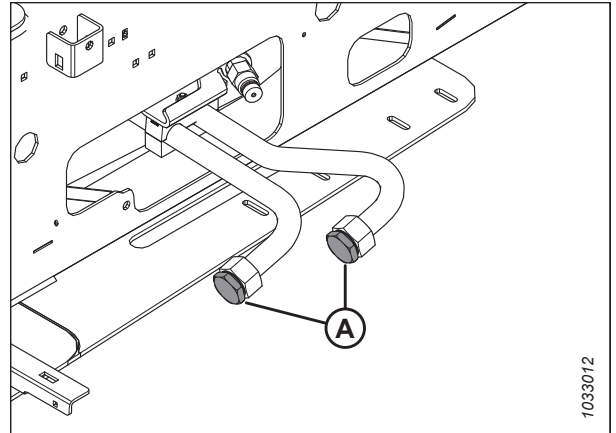

Figure 5.177: Pressure and Return Steel Lines with Plugs

5. **Quick coupler connections:** Connect male quick coupler (A) to pressure coupler (B). Connect female quick coupler (C) to return coupler (D).

NOTE:

For reference, other end (E) of the pressure hose is connected to the front of the hydraulic motor. End (F) of the return hose is connected to the rear of the hydraulic motor.

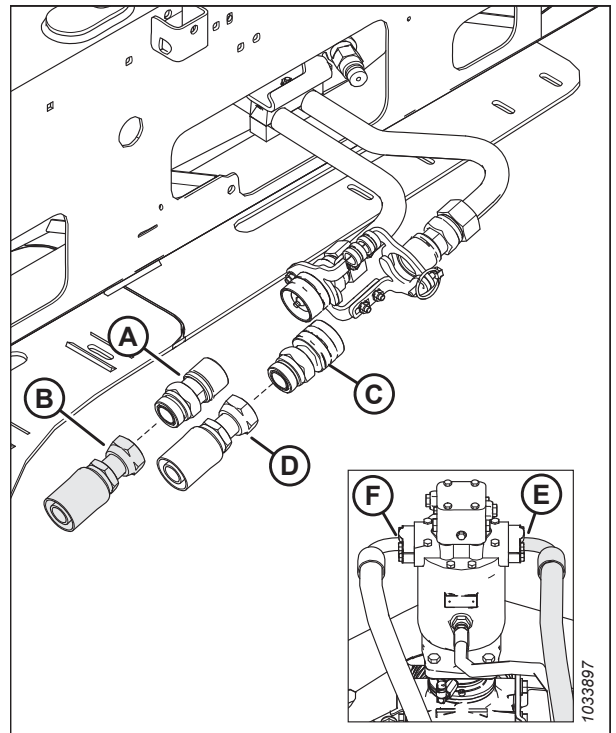

Figure 5.178: Header Pressure and Return Connections

ATTACHING ROTARY DISC HEADER TO WINDROWER

- Quick coupler connections:** Connect pressure coupler (A) to inboard steel line coupler (B).

NOTE:

For reference, other end (C) of the pressure hose is connected to the front of the hydraulic motor.

- Quick coupler connections:** Connect return coupler (D) to outboard steel line coupler (E).

NOTE:

For reference, other end (F) of the return hose is connected to the rear of the hydraulic motor.

- Quick coupler connections:** Close coupler lock assembly (G) over the couplers and secure it with pin (H).

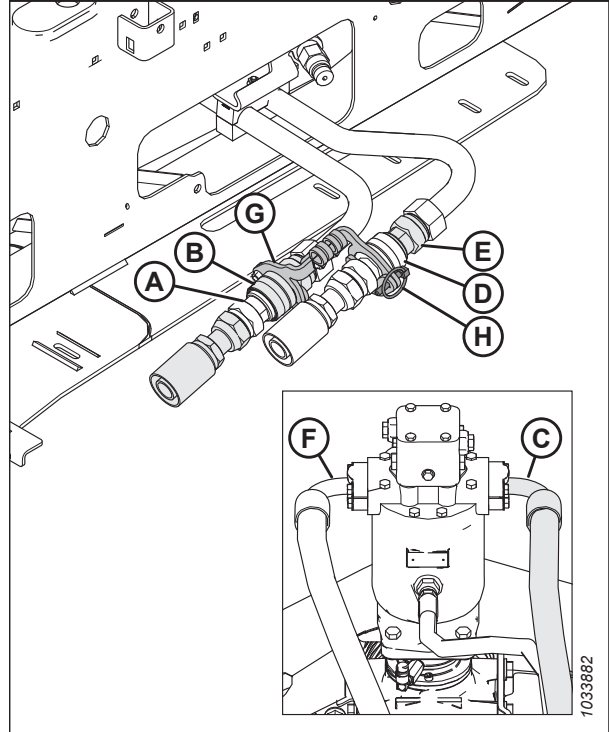

Figure 5.179: Header Pressure and Return Connections

- Quick coupler connections:** Ensure that the quick couplers are connected properly. Couplers will restrict oil flow if they are not fully mated (O-ring [A] will be visible). This will generate excessive heat, damaging the drive components and the couplers themselves. Couplers (B) are fully mated while couplers (C) are not fully mated.

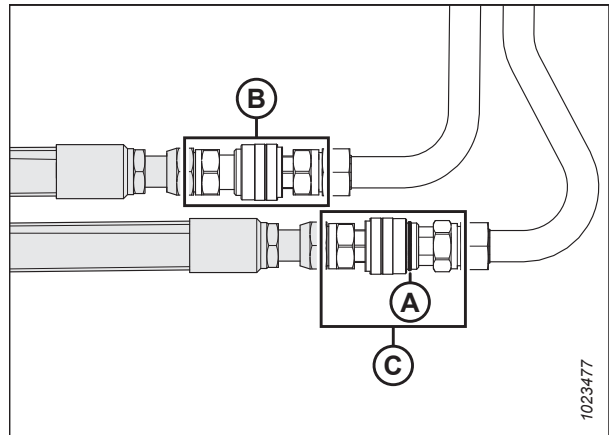

Figure 5.180: Quick Couplers – View from Above

ATTACHING ROTARY DISC HEADER TO WINDROWER

10. **Quick coupler connections:** Connect case drain hose (A) to 1/2 in. male flat face fitting (B) so that the relief valve points toward the ground.

NOTE:

For reference, the other end of the case drain hose is connected to hydraulic motor port (D).

NOTE:

Loosen and tighten fitting (B) as needed to ensure that the relief valve points toward the ground.

11. **Quick coupler connections:** Secure case drain hose to coupler lock assembly with two clamps (C).
12. **Quick coupler connections:** Proceed to Step 16, page 120.

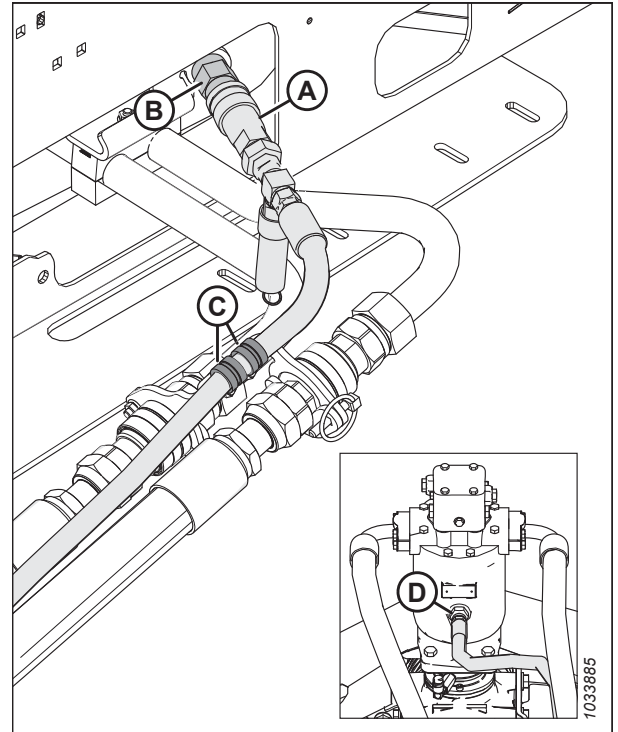

Figure 5.181: Case Drain Connection

13. **Hard-plumbed connections:** Connect pressure coupler (A) to inboard steel line (B) using adapter fittings (C) and (D).

NOTE:

For reference, other end (E) of the pressure hose is connected to the front of the hydraulic motor.

14. **Hard-plumbed connections:** Connect return coupler (G) to outboard steel line (H) using adapter fittings (J) and (K).

NOTE:

For reference, other end (L) of the return hose is connected to the rear of the hydraulic motor.

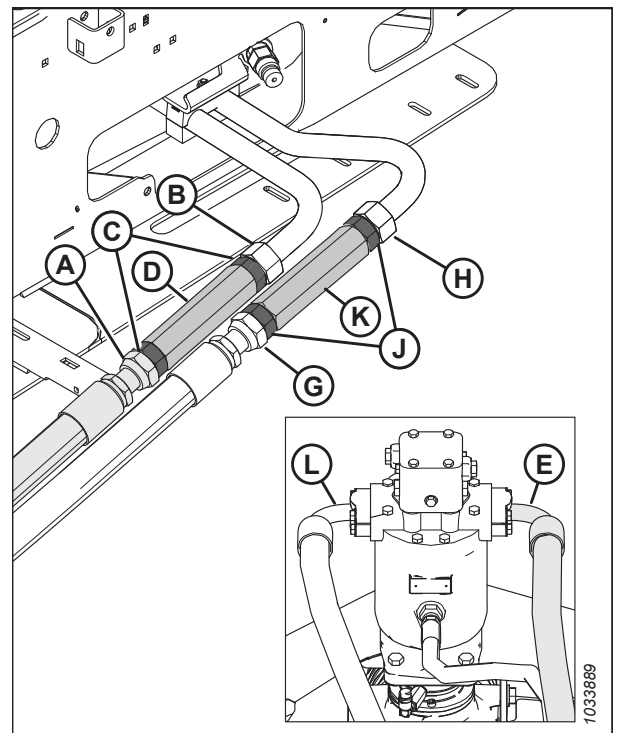

Figure 5.182: Header Pressure and Return Connections

ATTACHING ROTARY DISC HEADER TO WINDROWER

15. **Hard-plumbed connections:** Connect case drain hose (A) to 1/2 in. male flat face fitting (B) so that the relief valve points toward the ground.

NOTE:

For reference, the other end of the case drain hose is connected to hydraulic motor port (C).

NOTE:

Loosen and tighten fitting (B) as needed to ensure that the relief valve points toward the ground.

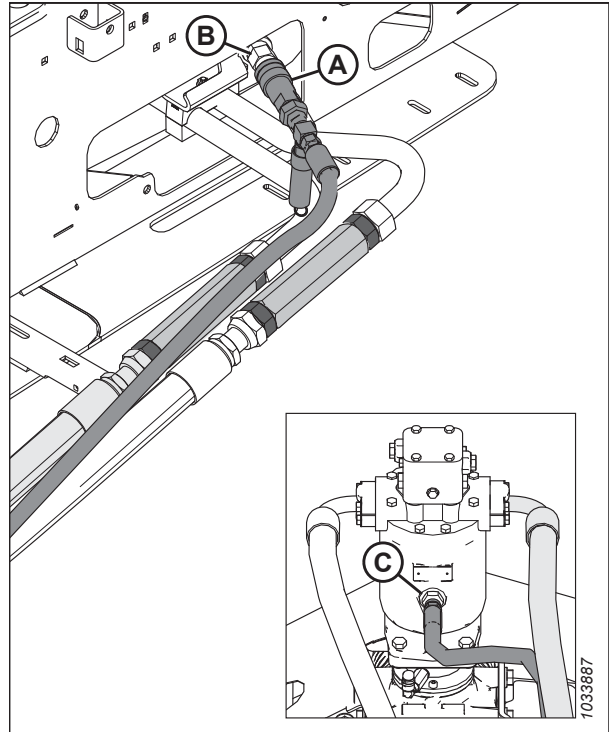

Figure 5.183: Case Drain Connection

16. Remove M205 adapter harness (A) from the storage location on center-link (B).
17. Connect harness (A) to header harness (C).

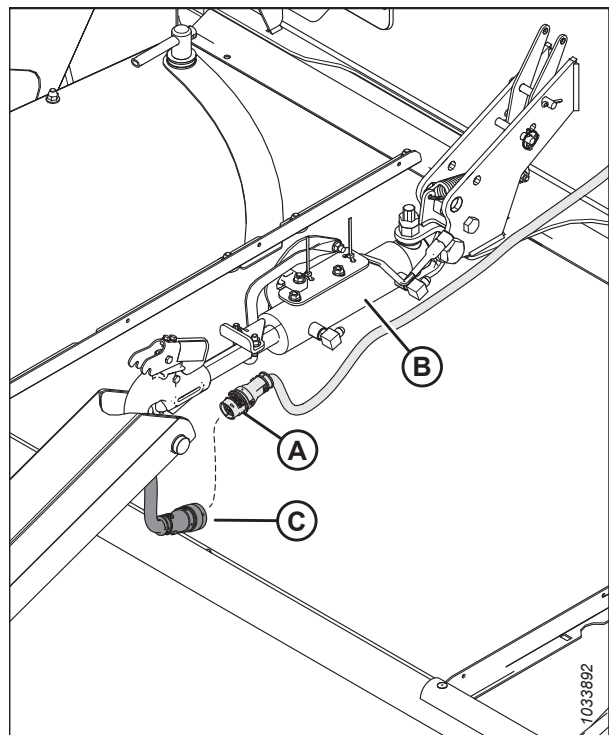

Figure 5.184: M205 Adapter Harness

5.9 Attaching R2 Series Rotary Disc Header to M155 SP Windrower

Follow the procedures below to safely attach the R216 Rotary Disc Header to an M155 Self-Propelled Windrower. The procedures differ somewhat depending on whether or not the windrower is equipped with a self-aligning hydraulic center-link.

NOTE:

To use an R216 Rotary Disc Header with an M155 Self-Propelled Windrower, the following kits must be installed first:

- Disc drive kit (B4657)
- M155E4 hydraulic drive kit (B7310)

Proceed to the relevant topic:

- To connect the header to an M155 Self-Propelled Windrower equipped with a self-aligning hydraulic center-link, proceed to [5.9.1 Attaching R2 Series Rotary Disc Header to M155 SP Windrower – Hydraulic Center-Link with Self-Alignment, page 121](#).
- To connect the header to an M155 Self-Propelled Windrower equipped with a non-self-aligning hydraulic center-link, proceed to [5.9.2 Attaching R2 Series Rotary Disc Header to M155 SP Windrower – Hydraulic Center-Link without Self-Alignment, page 127](#).

5.9.1 Attaching R2 Series Rotary Disc Header to M155 SP Windrower – Hydraulic Center-Link with Self-Alignment

The M155 Self-Propelled Windrower may be equipped with an optional self-aligning hydraulic center-link, which allows the Operator to control the vertical position of the center-link from the cab. This simplifies the process of attaching the R216 Rotary Disc Header to the windrower.

DANGER

To prevent bodily injury or death from the unexpected startup of the machine, always stop the engine and remove the key from the ignition before leaving the operator's seat for any reason.

1. Shut down the engine, and remove the key from the ignition.
2. Remove hairpin (A) from clevis pin (B), and remove the pin from header support (C).
3. Repeat the previous step on the other side of the header.

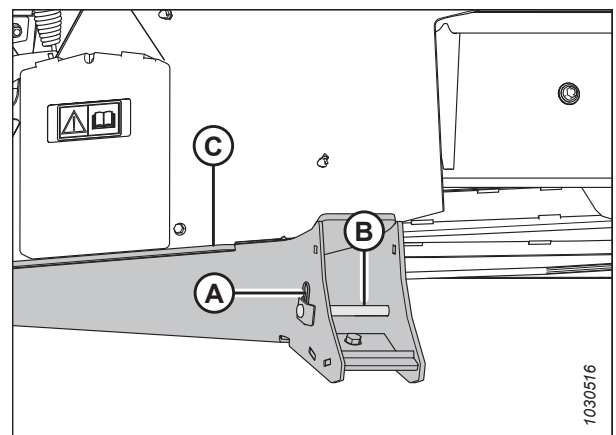

Figure 5.185: Header Support

ATTACHING ROTARY DISC HEADER TO WINDROWER

- Lift header support (A) and place 2 x 4 in. blocks (B) under the header support. A total of four 2 x 4 in. blocks (B) will be necessary to raise the boot up into field position. Ensure the boot's bottom edge (C) is parallel with the ground. Repeat for the opposite side.

NOTE:

Do **NOT** stack blocks (B) crosswise; doing so can make the header unstable. Stack blocks (B) so that the edges of the blocks are flush with each other.

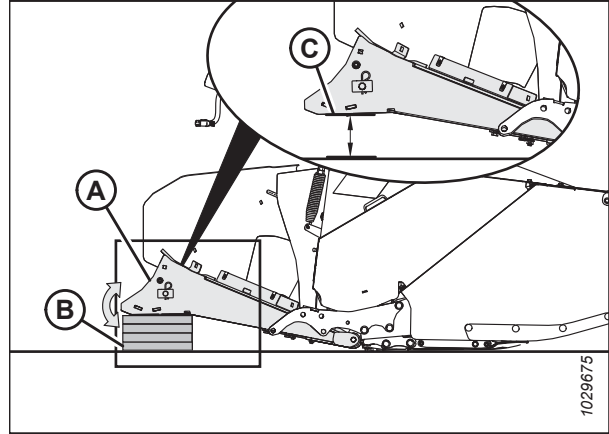

Figure 5.186: Header Support

- Remove the float engagement pin from hole (A) to disengage the float springs. Insert the float engagement pin into storage hole (B). Secure the engagement pin with the lynch pin.

IMPORTANT:

To prevent damage to the lift system when lowering the header lift linkages without a header or a weight box attached to the windrower, ensure that the float engagement pin is installed in storage hole (B) and **NOT** in engaged position (A).

- Repeat the previous step for the other float engagement pin.

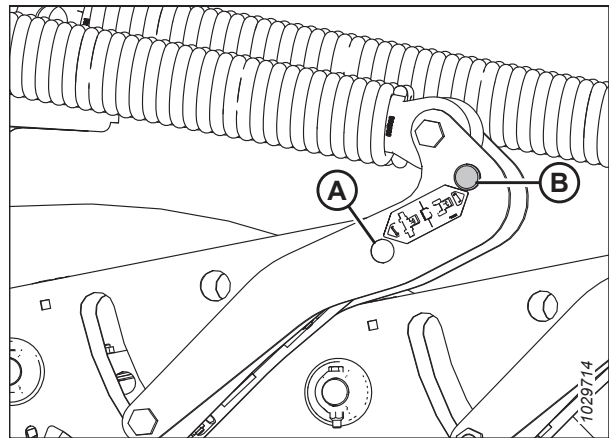

Figure 5.187: Float Linkage

DANGER

Ensure that all bystanders have cleared the area.

- Start the engine and activate HEADER DOWN button (A) on the ground speed lever (GSL) to fully retract the header lift cylinders.

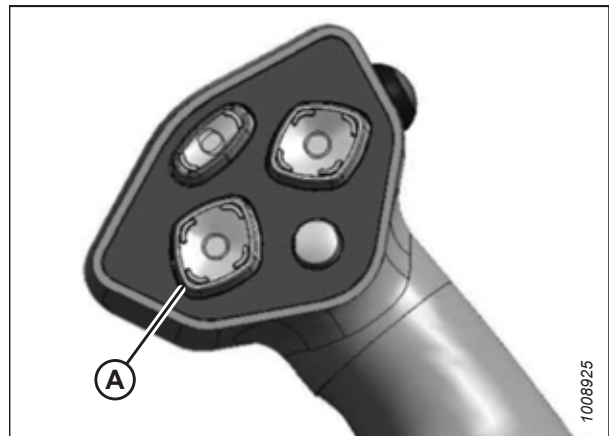

Figure 5.188: Ground Speed Lever

ATTACHING ROTARY DISC HEADER TO WINDROWER

8. Press REEL UP switch (A) on the GSL to raise the center-link until the hook is above the attachment pin on the header.

IMPORTANT:

If the center-link is too low, it may contact the header as the windrower approaches the header for hookup.

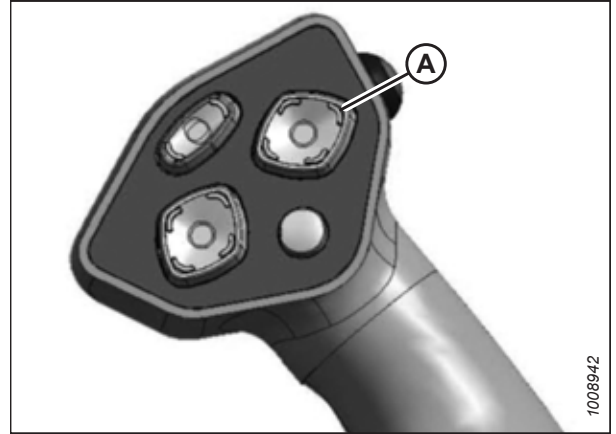

Figure 5.189: Ground Speed Lever

9. Slowly drive the windrower forward until windrower feet (A) enter header supports (B). Continue driving slowly forward until the feet engage the supports and the header is nudged forward.

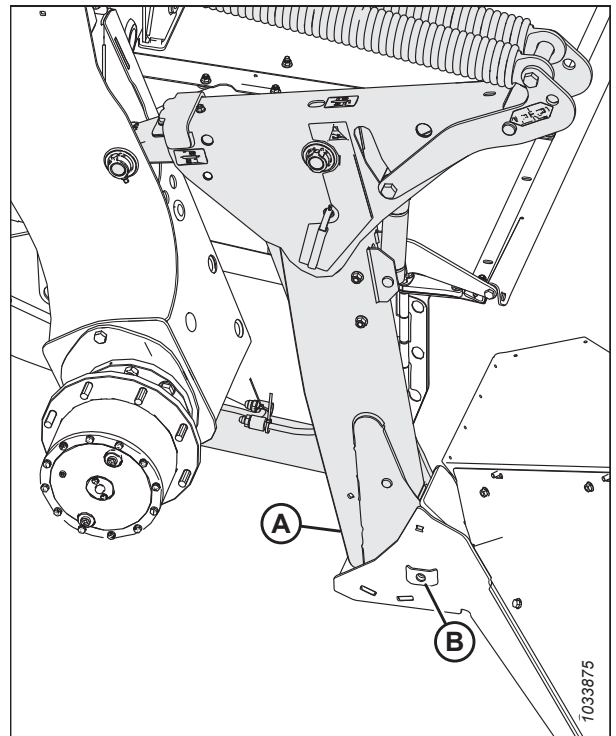

Figure 5.190: Header Support

ATTACHING ROTARY DISC HEADER TO WINDROWER

10. Use the following GSL functions to position the center-link hook above the header attachment pin:

- REEL UP (A) to raise the center-link
- REEL DOWN (B) to lower the center-link
- HEADER TILT UP (C) to retract the center-link
- HEADER TILT DOWN (D) to extend the center-link

IMPORTANT:

The hook release must be down to enable the self-locking mechanism. If the release is open (up), manually push it down after the hook engages the header pin.

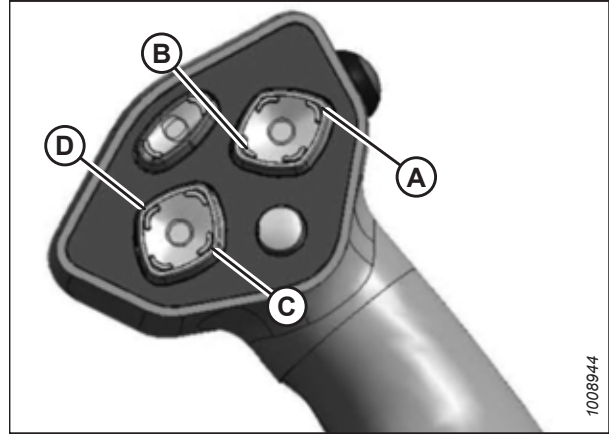

Figure 5.191: Ground Speed Lever

11. Adjust the position of center-link cylinder (A) with the REEL UP and REEL DOWN switches on the GSL until the hook is positioned above the header attachment pin.

IMPORTANT:

Hook release (B) must be down to enable the self-locking mechanism. If the release is open (up), manually push it down after the hook engages the header pin.

12. Lower center-link (A) onto the header using the REEL DOWN switch on the GSL until the center-link locks into position and hook release (B) is down.
13. Check that the center-link is locked onto the header by pressing the REEL UP switch on the GSL.

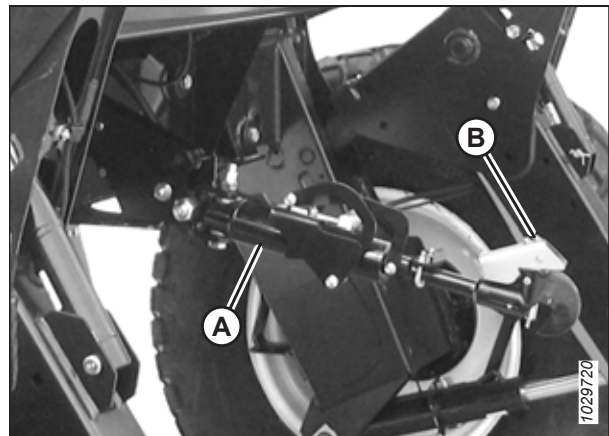

Figure 5.192: Hydraulic Center-Link

14. Press HEADER UP switch (A) to raise the header to its maximum height.

15. If one end of the header does **NOT** fully rise, rephase the lift cylinders as follows:

- a. Press and hold the HEADER UP switch until both cylinders stop moving.
- b. Continue to hold the switch for 3–4 seconds to fully phase the cylinders.

NOTE:

It may be necessary to repeat this procedure if there is air in the hydraulic system.



Figure 5.193: Ground Speed Lever

ATTACHING ROTARY DISC HEADER TO WINDROWER

16. To lower the safety props:
 - a. Pull lever (A) outward and rotate it toward the header to lower safety prop (B) onto the cylinder.
 - b. Repeat the previous step for the other safety prop.
 - c. Shut down the engine, and remove the key from the ignition.

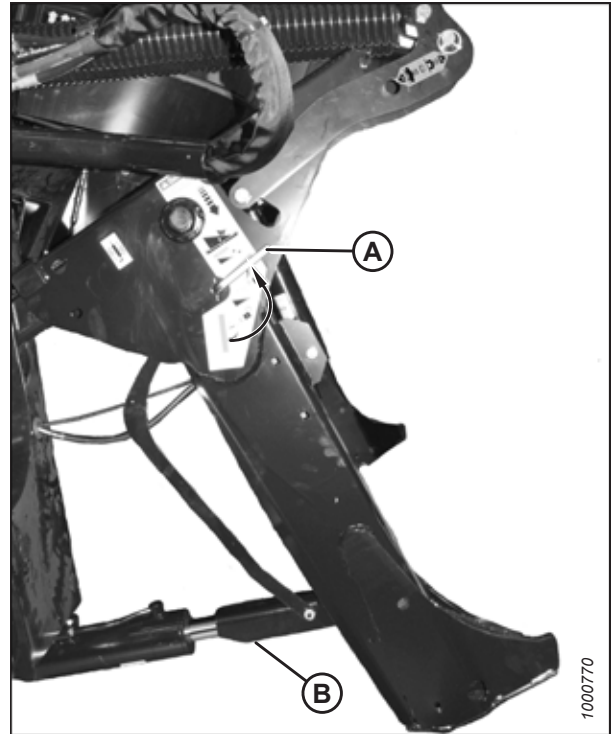

Figure 5.194: Safety Prop

17. Install clevis pin (A) through the support and the windrower foot. Secure the clevis pin with hairpin (B).

IMPORTANT:

Ensure that clevis pin (A) is fully inserted and that the hairpin is installed behind the bracket.

18. Repeat the previous step on the other side of the header.

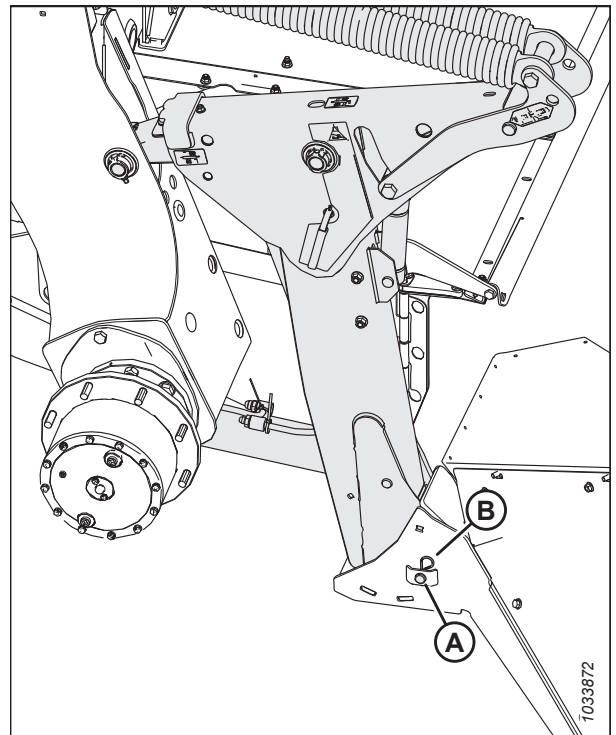

Figure 5.195: Header Support

ATTACHING ROTARY DISC HEADER TO WINDROWER

19. Remove the clevis pin from storage position (B) in the linkage and insert it into hole (A) to engage the float springs. Secure it with the hairpin. Repeat this step on the opposite float linkage.
20. Repeat the previous step for the other float engagement pin.

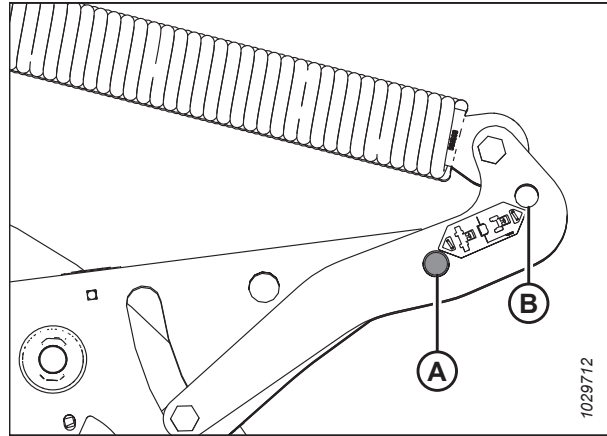

Figure 5.196: Header Float Linkage

21. Disengage the safety prop by turning lever (A) downwards until the lever locks into vertical position.
22. Repeat the previous step to disengage the other safety prop.

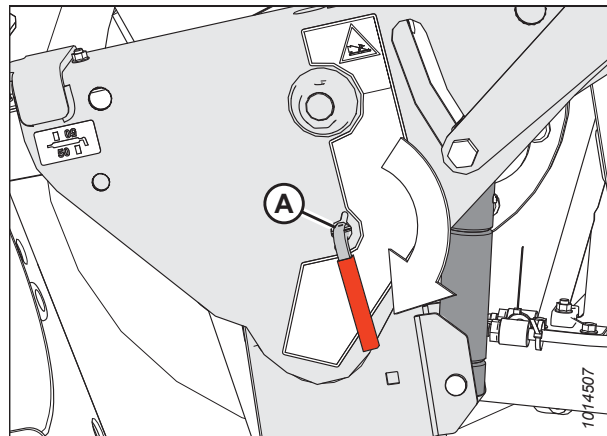

Figure 5.197: Safety Prop

23. Start the engine, and press HEADER DOWN switch (A) on the GSL to fully lower the header.
24. Shut down the engine, and remove the key from the ignition.
25. Proceed to [5.10.3 Connecting R2 Series Rotary Disc Header Hydraulics and Electrical – M155E4 SP Windrower, page 147](#).

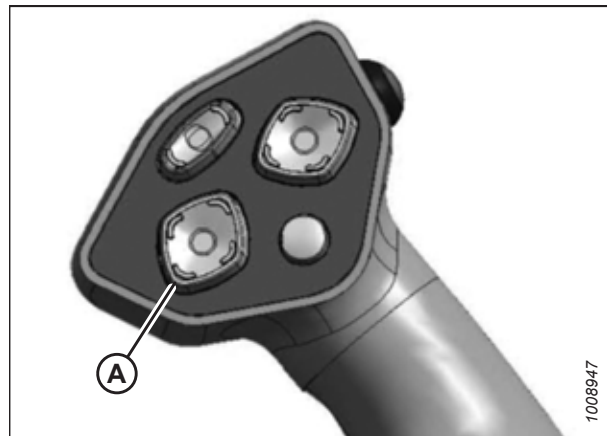

Figure 5.198: Ground Speed Lever

5.9.2 Attaching R2 Series Rotary Disc Header to M155 SP Windrower – Hydraulic Center-Link without Self-Alignment

If the M155 Self-Propelled Windrower is equipped with a hydraulic center-link that lacks self-alignment capability, the Operator will have to manually attach the hydraulic center-link's hook to the R216 Rotary Disc Header's center pin.

DANGER

To prevent bodily injury or death from the unexpected startup of the machine, always stop the engine and remove the key from the ignition before leaving the operator's seat for any reason.

1. Shut down the engine, and remove the key from the ignition.
2. Remove hairpin (A) from clevis pin (B), and remove the pin from header support (C).
3. Repeat the previous step on the other side of the header.

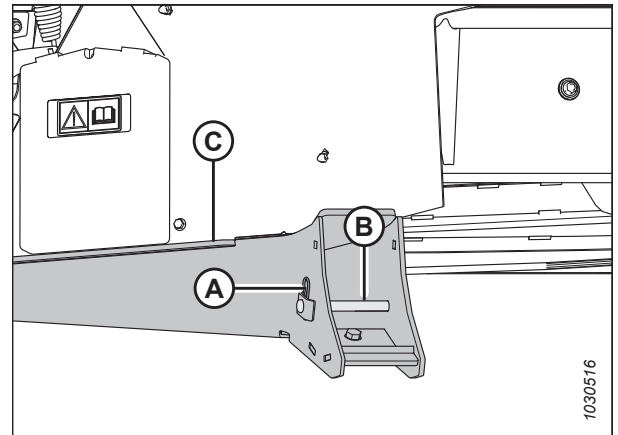

Figure 5.199: Header Support

4. Lift header support (A) and place 2 x 4 in. blocks (B) under the header support. A total of four 2 x 4 in. blocks (B) will be necessary to raise the boot up into field position. Ensure the boot's bottom edge (C) is parallel with the ground. Repeat for the opposite side.

NOTE:

Do **NOT** stack blocks (B) crosswise; doing so can make the header unstable. Stack blocks (B) so that the edges of the blocks are flush with each other.

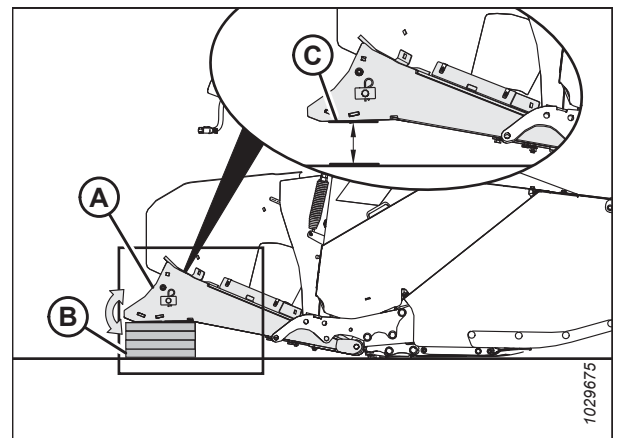

Figure 5.200: Header Support

ATTACHING ROTARY DISC HEADER TO WINDROWER

5. Remove the float engagement pin from hole (A) to disengage the float springs. Insert the float engagement pin into storage hole (B). Secure the engagement pin with the lynch pin.

IMPORTANT:

To prevent damage to the lift system when lowering the header lift linkages without a header or a weight box attached to the windrower, ensure that the float engagement pin is installed in storage hole (B) and **NOT** in engaged position (A).

6. Repeat the previous step for the other float engagement pin.

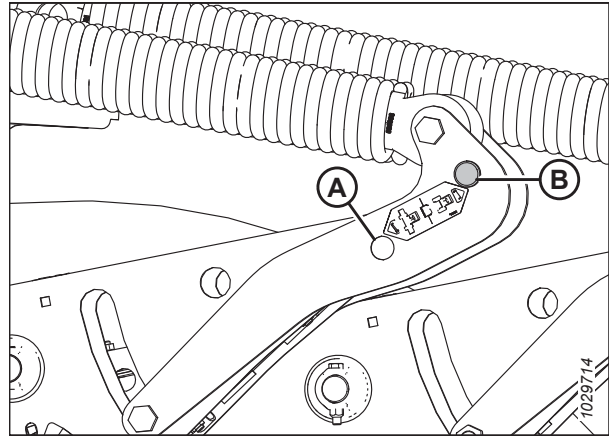

Figure 5.201: Float Linkage

DANGER

Ensure that all bystanders have cleared the area.

7. Start the engine and activate HEADER DOWN button (A) on the ground speed lever (GSL) to fully retract the header lift cylinders.

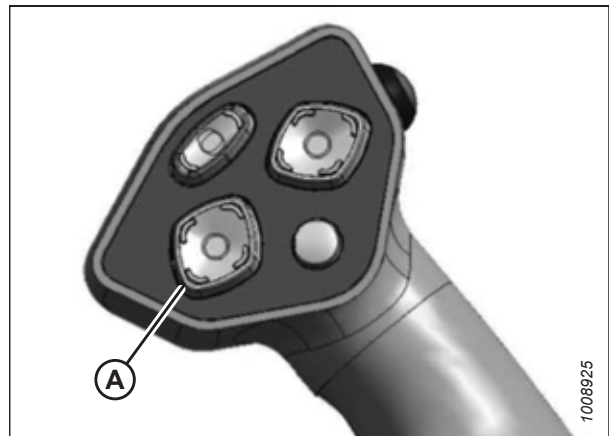

Figure 5.202: Ground Speed Lever

8. Remove pin (A) from the frame linkage and raise center-link (B) until the hook is above the attachment pin on the header. Replace pin (A) to hold the center-link in place.

IMPORTANT:

If the center-link is too low, it may contact the header as the windrower approaches the header for hookup.

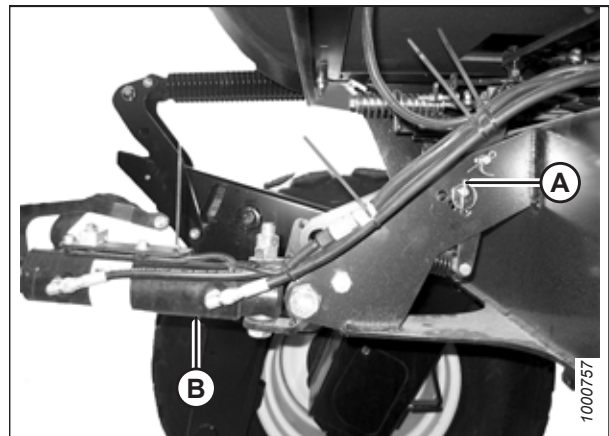

Figure 5.203: Hydraulic Center-Link

ATTACHING ROTARY DISC HEADER TO WINDROWER

9. Slowly drive the windrower forward until windrower feet (A) enter header supports (B). Continue driving slowly forward until the feet engage the supports and the header is nudged forward.

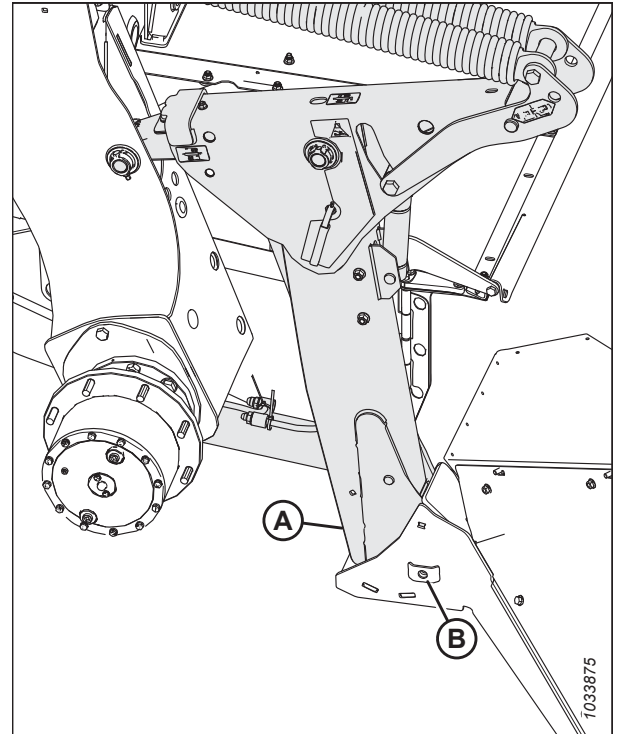

Figure 5.204: Header Support

10. Use the following GSL functions to position the center-link hook above the header attachment pin:
 - HEADER TILT UP (A) to retract the center-link
 - HEADER TILT DOWN (B) to extend the center-link
11. Stop the engine, and remove the key from the ignition.

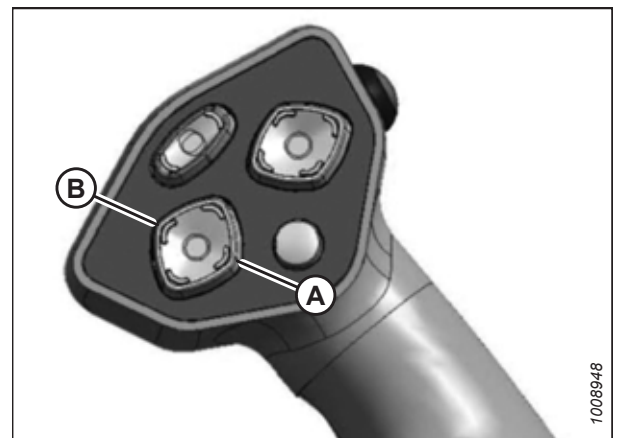

Figure 5.205: Ground Speed Lever

ATTACHING ROTARY DISC HEADER TO WINDROWER

12. Push down on the rod end of link cylinder (A) until hook (B) engages and locks onto the header pin.

IMPORTANT:

The hook release must be down to enable the self-locking mechanism. If the release is open (up), manually push it down after the hook engages the header pin.

13. Check that center-link (A) is locked onto the header by pulling upward on the rod end of the cylinder.
14. Start the engine.

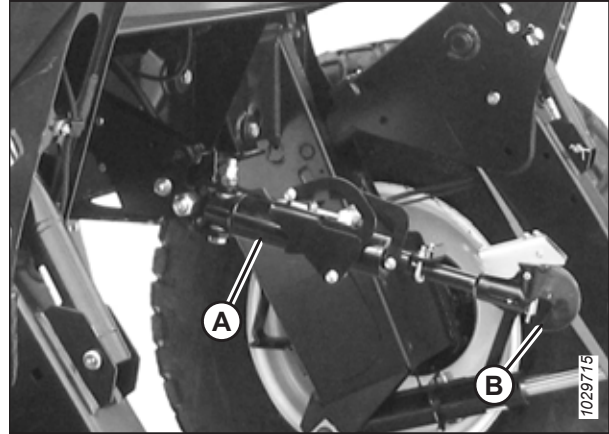

Figure 5.206: Hydraulic Center-Link

15. Press HEADER UP switch (A) to raise the header to its maximum height.
16. If one end of the header does **NOT** fully rise, rephase the lift cylinders as follows:
 - a. Press and hold the HEADER UP switch until both cylinders stop moving.
 - b. Continue to hold the switch for 3–4 seconds to fully phase the cylinders.

NOTE:

It may be necessary to repeat this procedure if there is air in the hydraulic system.



Figure 5.207: Ground Speed Lever

ATTACHING ROTARY DISC HEADER TO WINDROWER

17. To lower the safety props:
 - a. Pull lever (A) outward and rotate it toward the header to lower safety prop (B) onto the cylinder.
 - b. Repeat the previous step for the other safety prop.
 - c. Shut down the engine, and remove the key from the ignition.

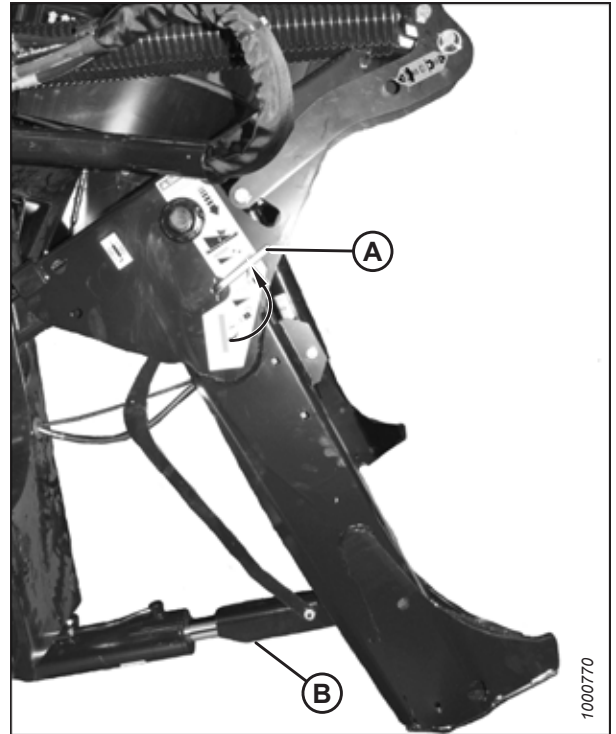

Figure 5.208: Safety Prop

18. Install clevis pin (A) through the support and the windrower foot. Secure the clevis pin with hairpin (B).

IMPORTANT:

Ensure that clevis pin (A) is fully inserted and that the hairpin is installed behind the bracket.

19. Repeat the previous step on the other side of the header.

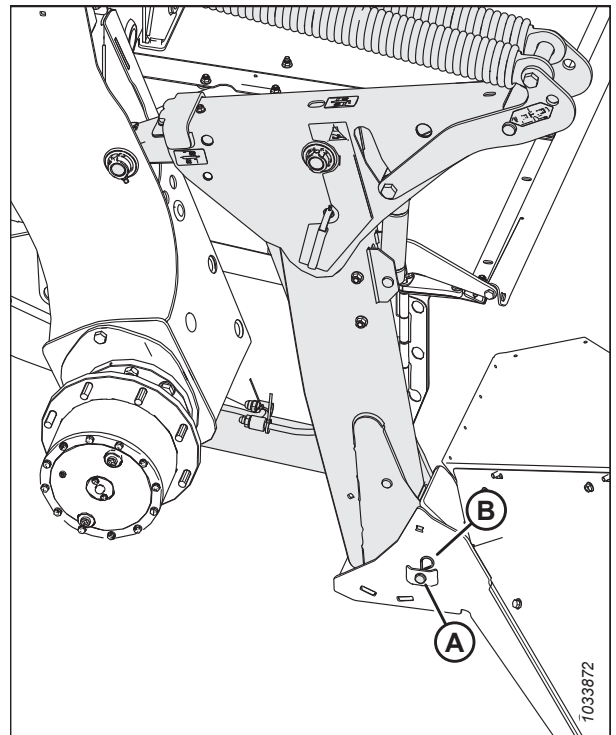

Figure 5.209: Header Support

ATTACHING ROTARY DISC HEADER TO WINDROWER

20. Remove the clevis pin from storage position (B) in the linkage and insert it into hole (A) to engage the float springs. Secure it with the hairpin. Repeat this step on the opposite float linkage.
21. Repeat the previous step for the other float engagement pin.

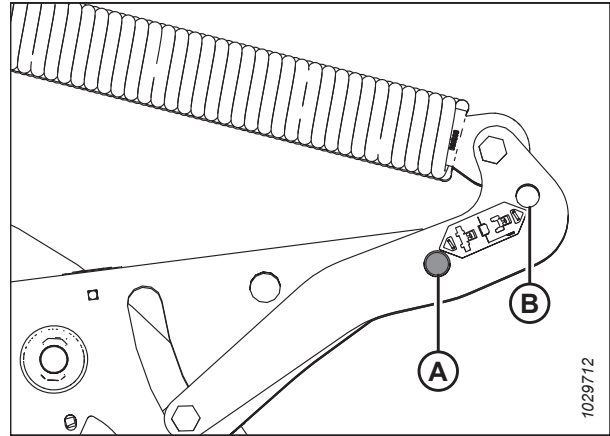

Figure 5.210: Header Float Linkage

22. Disengage the safety prop by turning lever (A) downwards until the lever locks into vertical position.
23. Repeat the previous step to disengage the other safety prop.

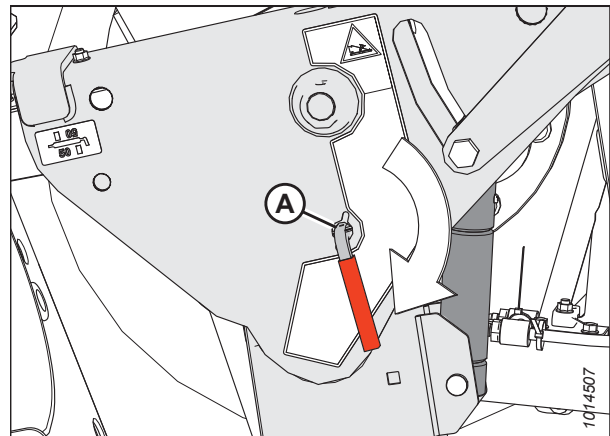

Figure 5.211: Safety Prop

24. Start the engine, and press HEADER DOWN switch (A) on the GSL to fully lower the header.
25. Shut down the engine, and remove the key from the ignition.

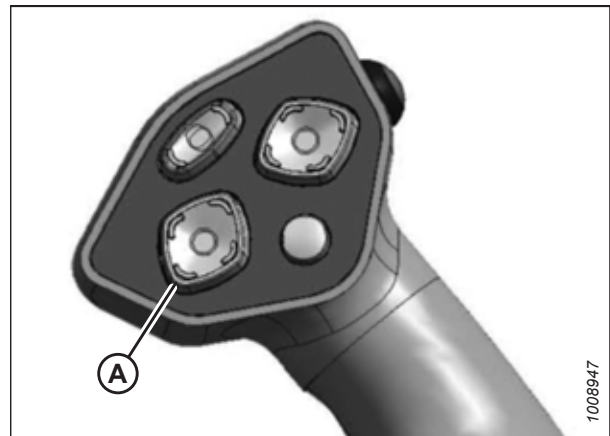

Figure 5.212: Ground Speed Lever

5.9.3 Connecting R2 Series Rotary Disc Header Hydraulics and Electrical to M155 SP Windrower

Once the R216 Rotary Disc Header is attached to the M155 Self-Propelled Windrower, the hydraulic and electrical connections must be completed.

1. Connect the windrower's hydraulic hoses to the header's hydraulic hoses. Refer to the illustrations provided for guidance. The callout letters in the first illustration correspond to those in the second; (i.e: upper pressure hose [A] in the first illustration corresponds to upper pressure hose [A] in the second illustration):

- (A) Upper pressure hose
- (B) Lower pressure hose
- (C) Return hose
- (D) Case drain hose

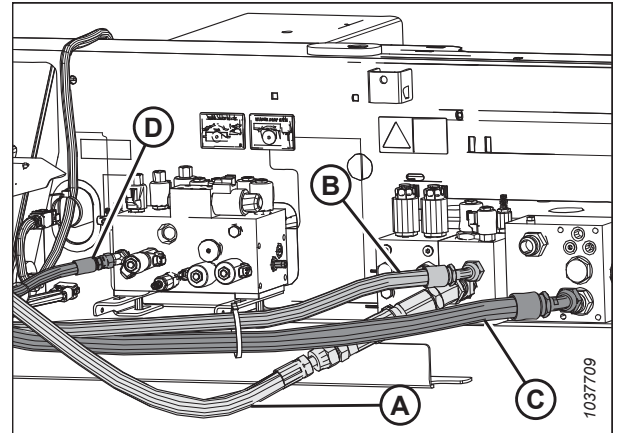

Figure 5.213: Windrower Hydraulic Hoses Connected to Hydraulic Block

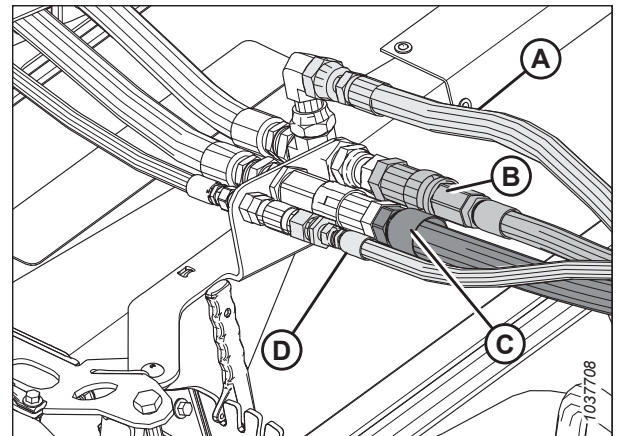

Figure 5.214: Windrower Hydraulic Hoses Connected to Header – View from Rear of Header

ATTACHING ROTARY DISC HEADER TO WINDROWER

2. Locate windrower adapter harness (A) on the windrower's center-link. Remove windrower adapter harness (A) from its storage location on center-link (B).
3. Connect harness (A) to header harness (C).

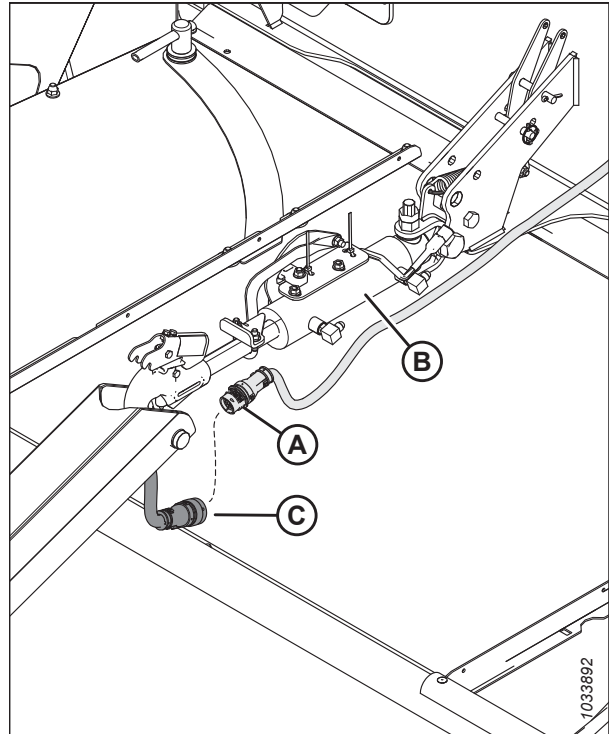

Figure 5.215: Windrower Adapter Harness

NOTE:

When the harness is not in use, secure harness (A) to the center-link tilt cylinder using strap (B).

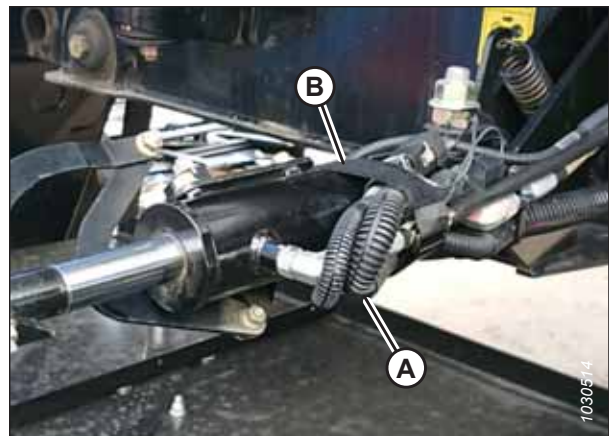

Figure 5.216: Adapter Harness Secured to Center-Link

4. Proceed to [5.11 Setting the Header Cut Width, page 149](#).

5.10 Attaching R2 Series Rotary Disc Header to M155E4 SP Windrower

Follow the procedures below to safely attach the R216 Rotary Disc Header to an M155E4 Self-Propelled Windrower. The procedures differ somewhat depending on whether or not the windrower is equipped with a self-aligning hydraulic center-link.

NOTE:

To use an R216 Rotary Disc Header with an M155E4 Self-Propelled Windrower, the following kits must be installed first:

- Disc drive kit (B4657)
- M155E4 hydraulic drive kit (B7310)

Proceed to the relevant topic:

- To connect the header to an M155E4 Self-Propelled Windrower equipped with a self-aligning hydraulic center-link, proceed to [5.10.1 Attaching R2 Series Rotary Disc Header to M155E4 SP Windrower – Hydraulic Center-Link with Self-Alignment, page 135](#).
- To connect the header to an M155E4 Self-Propelled Windrower equipped with a non-self-aligning hydraulic center-link, proceed to [5.10.2 Attaching R2 Series Rotary Disc Header to M155E4 SP Windrower – Hydraulic Center-Link without Self-Alignment, page 141](#).

5.10.1 Attaching R2 Series Rotary Disc Header to M155E4 SP Windrower – Hydraulic Center-Link with Self-Alignment

The M155E4 Self-Propelled Windrower may be equipped with an optional self-aligning hydraulic center-link, which allows the Operator to control the vertical position of the center-link from the cab. This simplifies the process of attaching the R216 Rotary Disc Header to the windrower.

DANGER

To prevent bodily injury or death from the unexpected startup of the machine, always stop the engine and remove the key from the ignition before leaving the operator's seat for any reason.

1. Shut down the engine, and remove the key from the ignition.
2. Remove hairpin (A) from clevis pin (B), and remove the pin from header support (C).
3. Repeat the previous step on the other side of the header.

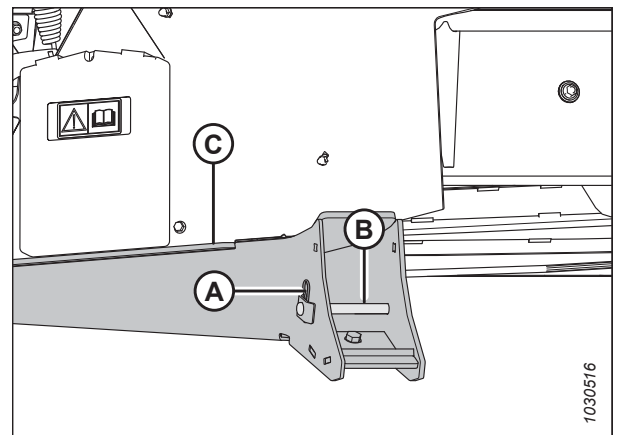

Figure 5.217: Header Support

ATTACHING ROTARY DISC HEADER TO WINDROWER

- Lift header support (A) and place 2 x 4 in. blocks (B) under the header support. A total of four 2 x 4 in. blocks (B) will be necessary to raise the boot up into field position. Ensure the boot's bottom edge (C) is parallel with the ground. Repeat for the opposite side.

NOTE:

Do **NOT** stack blocks (B) crosswise; doing so can make the header unstable. Stack blocks (B) so that the edges of the blocks are flush with each other.

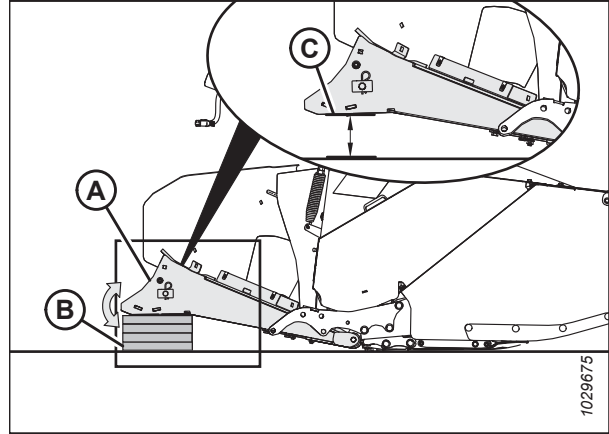

Figure 5.218: Header Support

- Remove the float engagement pin from hole (A) to disengage the float springs. Insert the float engagement pin into storage hole (B). Secure the engagement pin with the lynch pin.

IMPORTANT:

To prevent damage to the lift system when lowering the header lift linkages without a header or a weight box attached to the windrower, ensure that the float engagement pin is installed in storage hole (B) and **NOT** in engaged position (A).

- Repeat the previous step for the other float engagement pin.

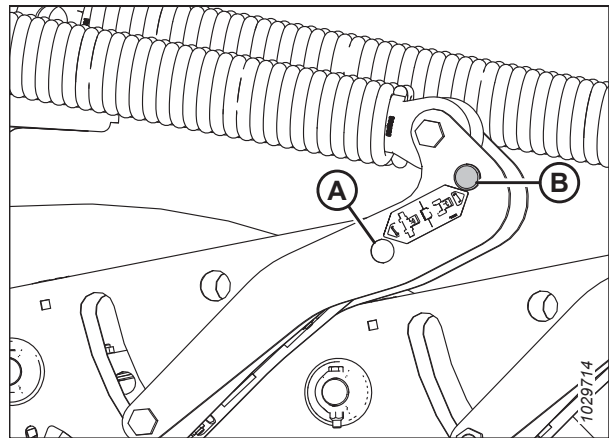

Figure 5.219: Float Linkage

DANGER

Ensure that all bystanders have cleared the area.

- Start the engine and activate HEADER DOWN button (A) on the ground speed lever (GSL) to fully retract the header lift cylinders.

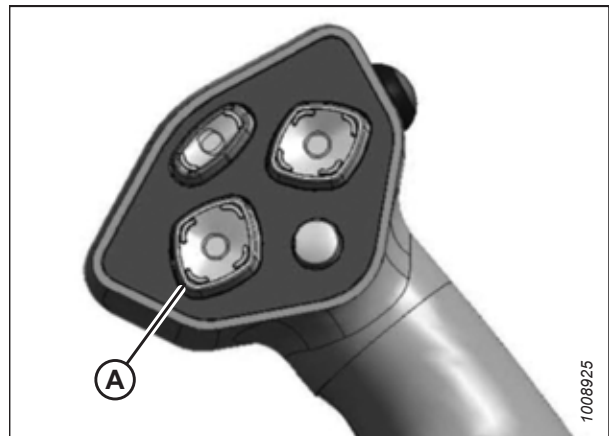

Figure 5.220: Ground Speed Lever

ATTACHING ROTARY DISC HEADER TO WINDROWER

8. Press REEL UP switch (A) on the GSL to raise the center-link until the hook is above the attachment pin on the header.

IMPORTANT:

If the center-link is too low, it may contact the header as the windrower approaches the header for hookup.

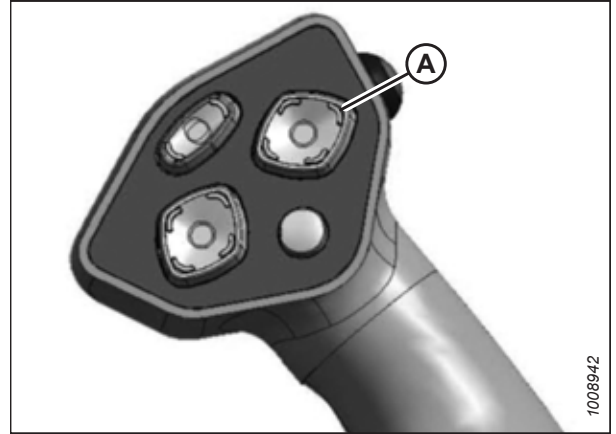

Figure 5.221: Ground Speed Lever

9. Slowly drive the windrower forward until windrower feet (A) enter header supports (B). Continue driving slowly forward until the feet engage the supports and the header is nudged forward.

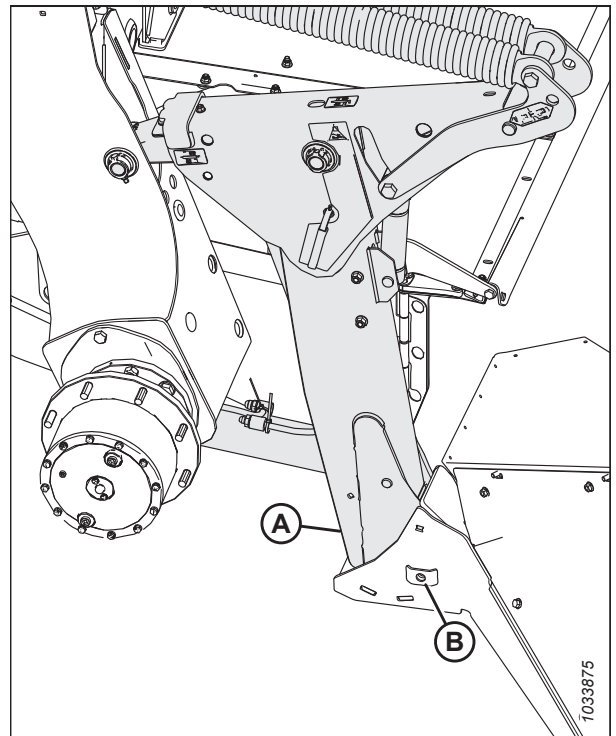

Figure 5.222: Header Support

ATTACHING ROTARY DISC HEADER TO WINDROWER

10. Use the following GSL functions to position the center-link hook above the header attachment pin:

- REEL UP (A) to raise the center-link
- REEL DOWN (B) to lower the center-link
- HEADER TILT UP (C) to retract the center-link
- HEADER TILT DOWN (D) to extend the center-link

IMPORTANT:

The hook release must be down to enable the self-locking mechanism. If the release is open (up), manually push it down after the hook engages the header pin.

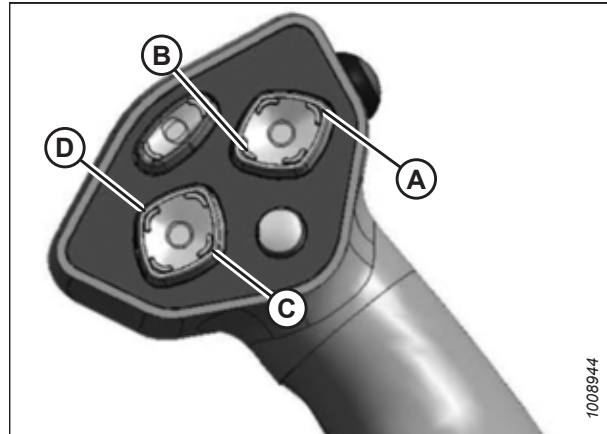

Figure 5.223: Ground Speed Lever

11. Adjust the position of center-link cylinder (A) with the REEL UP and REEL DOWN switches on the GSL until the hook is positioned above the header attachment pin.

IMPORTANT:

Hook release (B) must be down to enable the self-locking mechanism. If the release is open (up), manually push it down after the hook engages the header pin.

12. Lower center-link (A) onto the header using the REEL DOWN switch on the GSL until the center-link locks into position and hook release (B) is down.
13. Check that the center-link is locked onto the header by pressing the REEL UP switch on the GSL.

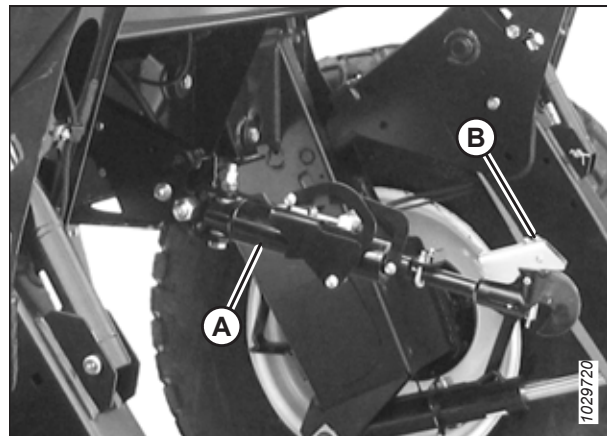

Figure 5.224: Hydraulic Center-Link

14. Press HEADER UP switch (A) to raise the header to its maximum height.

15. If one end of the header does **NOT** fully rise, rephase the lift cylinders as follows:

- a. Press and hold the HEADER UP switch until both cylinders stop moving.
- b. Continue to hold the switch for 3–4 seconds to fully phase the cylinders.

NOTE:

It may be necessary to repeat this procedure if there is air in the hydraulic system.



Figure 5.225: Ground Speed Lever

ATTACHING ROTARY DISC HEADER TO WINDROWER

16. To lower the safety props:
 - a. Pull lever (A) outward and rotate it toward the header to lower safety prop (B) onto the cylinder.
 - b. Repeat the previous step for the other safety prop.
 - c. Shut down the engine, and remove the key from the ignition.

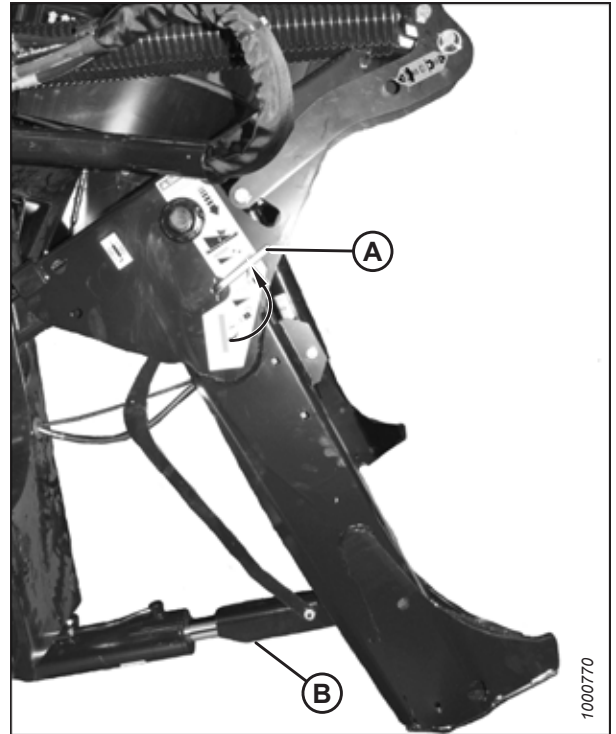

Figure 5.226: Safety Prop

17. Install clevis pin (A) through the support and the windrower foot. Secure the clevis pin with hairpin (B).

IMPORTANT:

Ensure that clevis pin (A) is fully inserted and that the hairpin is installed behind the bracket.

18. Repeat the previous step on the other side of the header.

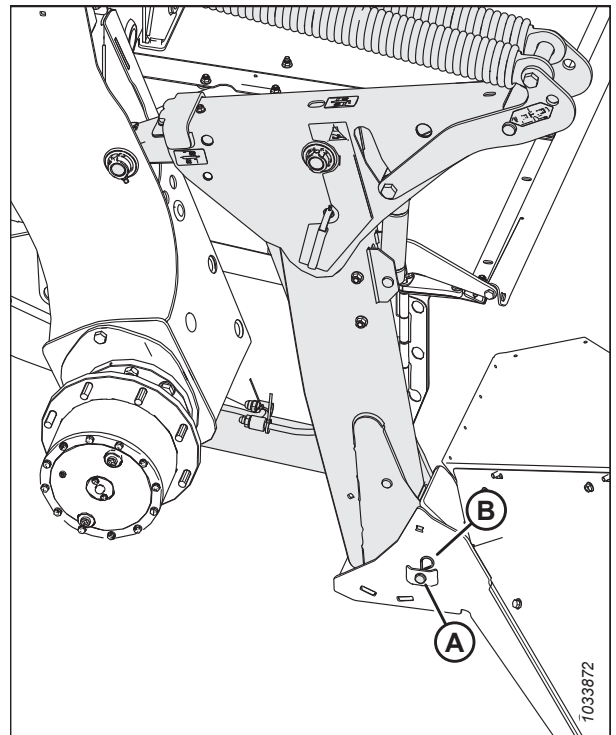

Figure 5.227: Header Support

ATTACHING ROTARY DISC HEADER TO WINDROWER

19. Remove the clevis pin from storage position (B) in the linkage and insert it into hole (A) to engage the float springs. Secure it with the hairpin. Repeat this step on the opposite float linkage.
20. Repeat the previous step for the other float engagement pin.

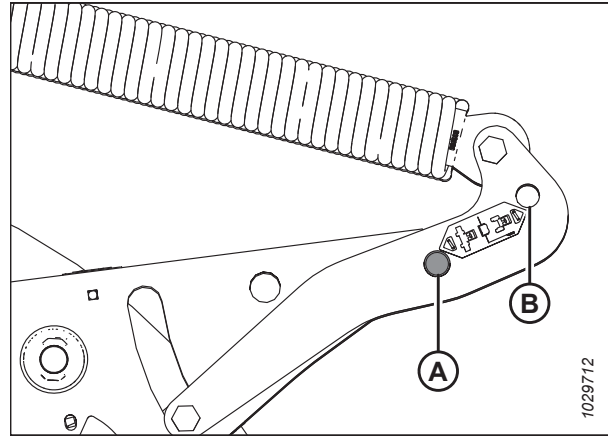

Figure 5.228: Header Float Linkage

21. Disengage the safety prop by turning lever (A) downwards until the lever locks into vertical position.
22. Repeat the previous step to disengage the other safety prop.

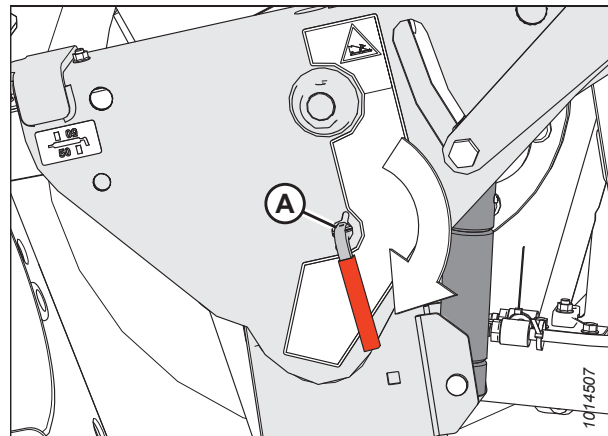

Figure 5.229: Safety Prop

23. Start the engine, and press HEADER DOWN switch (A) on the GSL to fully lower the header.
24. Shut down the engine, and remove the key from the ignition.
25. Proceed to [5.10.3 Connecting R2 Series Rotary Disc Header Hydraulics and Electrical – M155E4 SP Windrower, page 147](#).

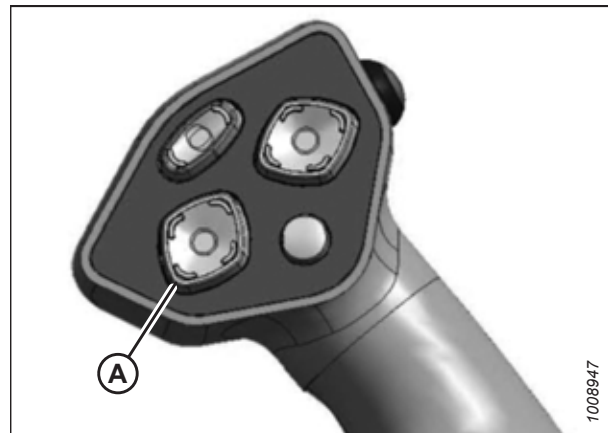

Figure 5.230: Ground Speed Lever

5.10.2 Attaching R2 Series Rotary Disc Header to M155E4 SP Windrower – Hydraulic Center-Link without Self-Alignment

If the M155E4 Self-Propelled Windrower is equipped with a hydraulic center-link that lacks self-alignment capability, the Operator will have to manually attach the hydraulic center-link's hook to the R216 Rotary Disc Header's center pin.

DANGER

To prevent bodily injury or death from the unexpected startup of the machine, always stop the engine and remove the key from the ignition before leaving the operator's seat for any reason.

1. Shut down the engine, and remove the key from the ignition.
2. Remove hairpin (A) from clevis pin (B), and remove the pin from header support (C).
3. Repeat the previous step on the other side of the header.

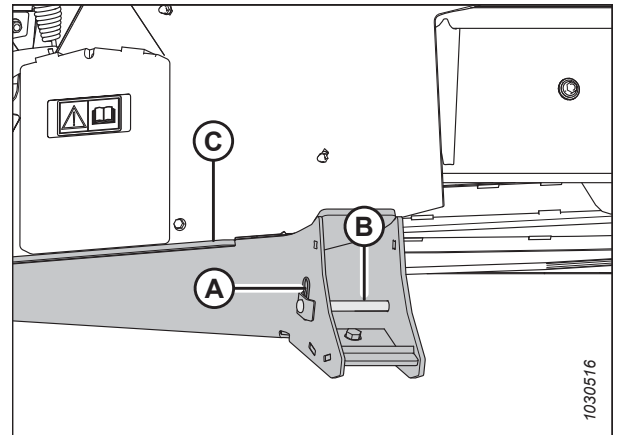

Figure 5.231: Header Support

4. Lift header support (A) and place 2 x 4 in. blocks (B) under the header support. A total of four 2 x 4 in. blocks (B) will be necessary to raise the boot up into field position. Ensure the boot's bottom edge (C) is parallel with the ground. Repeat for the opposite side.

NOTE:

Do **NOT** stack blocks (B) crosswise; doing so can make the header unstable. Stack blocks (B) so that the edges of the blocks are flush with each other.

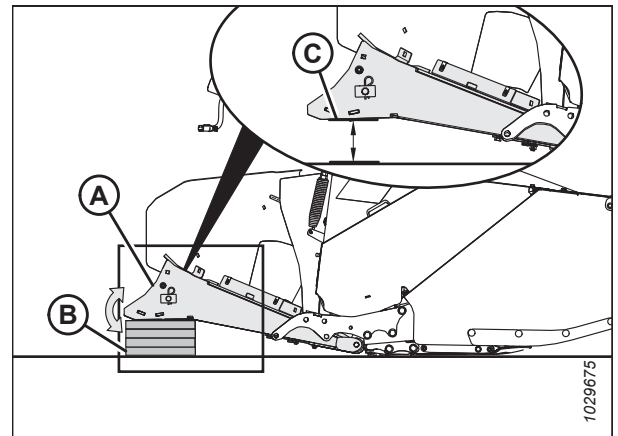

Figure 5.232: Header Support

ATTACHING ROTARY DISC HEADER TO WINDROWER

5. Remove the float engagement pin from hole (A) to disengage the float springs. Insert the float engagement pin into storage hole (B). Secure the engagement pin with the lynch pin.

IMPORTANT:

To prevent damage to the lift system when lowering the header lift linkages without a header or a weight box attached to the windrower, ensure that the float engagement pin is installed in storage hole (B) and **NOT** in engaged position (A).

6. Repeat the previous step for the other float engagement pin.

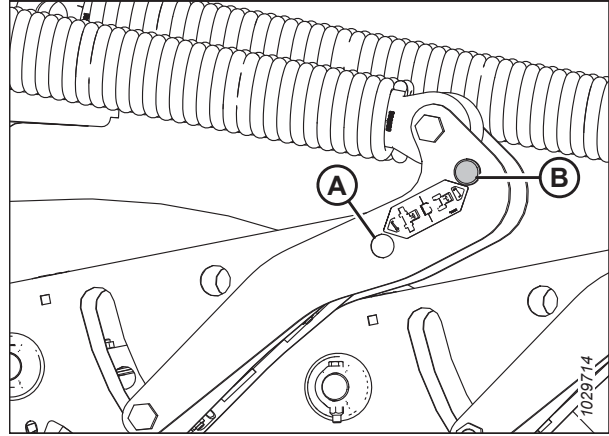

Figure 5.233: Float Linkage

DANGER

Ensure that all bystanders have cleared the area.

7. Start the engine and activate HEADER DOWN button (A) on the ground speed lever (GSL) to fully retract the header lift cylinders.

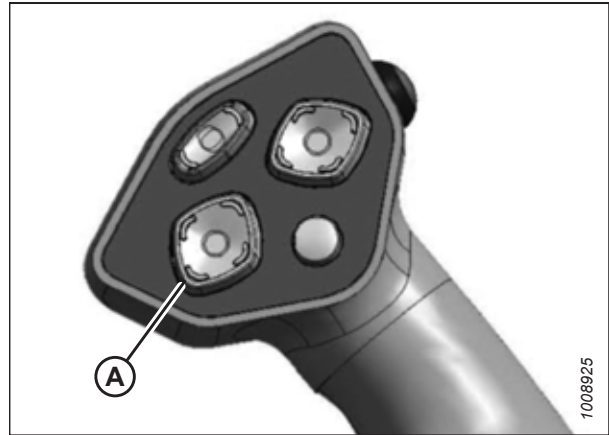

Figure 5.234: Ground Speed Lever

8. Remove pin (A) from the frame linkage and raise center-link (B) until the hook is above the attachment pin on the header. Replace pin (A) to hold the center-link in place.

IMPORTANT:

If the center-link is too low, it may contact the header as the windrower approaches the header for hookup.

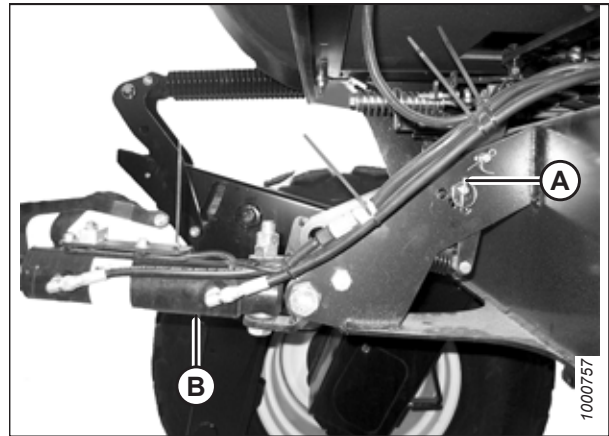

Figure 5.235: Hydraulic Center-Link

ATTACHING ROTARY DISC HEADER TO WINDROWER

9. Slowly drive the windrower forward until windrower feet (A) enter header supports (B). Continue driving slowly forward until the feet engage the supports and the header is nudged forward.

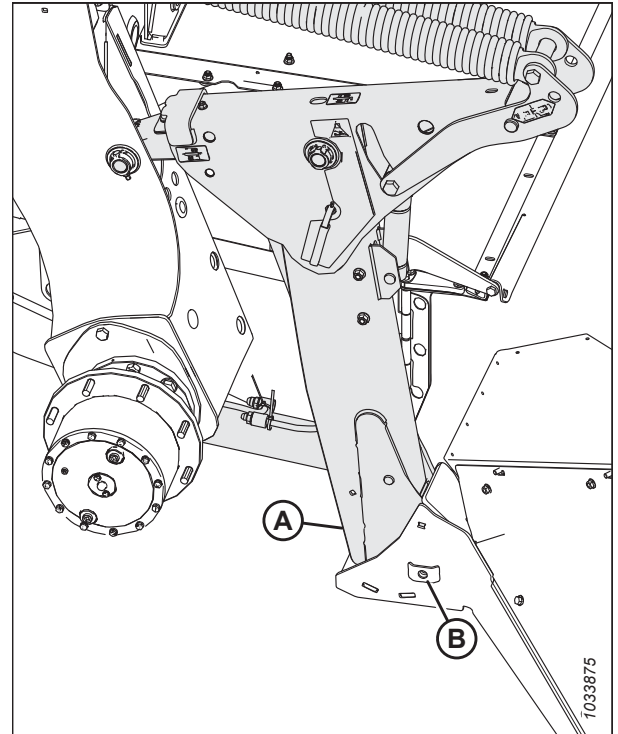

Figure 5.236: Header Support

10. Use the following GSL functions to position the center-link hook above the header attachment pin:
 - HEADER TILT UP (A) to retract the center-link
 - HEADER TILT DOWN (B) to extend the center-link
11. Stop the engine, and remove the key from the ignition.

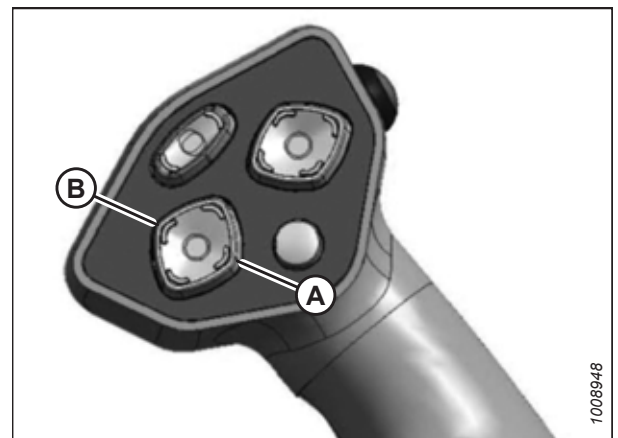

Figure 5.237: Ground Speed Lever

ATTACHING ROTARY DISC HEADER TO WINDROWER

12. Push down on the rod end of link cylinder (A) until hook (B) engages and locks onto the header pin.

IMPORTANT:

The hook release must be down to enable the self-locking mechanism. If the release is open (up), manually push it down after the hook engages the header pin.

13. Check that center-link (A) is locked onto the header by pulling upward on the rod end of the cylinder.
14. Start the engine.

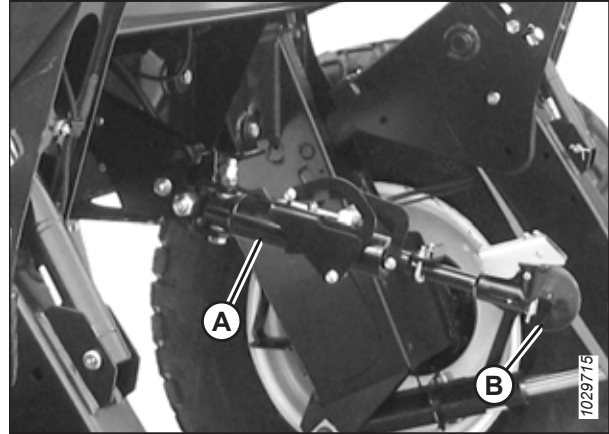

Figure 5.238: Hydraulic Center-Link

15. Press HEADER UP switch (A) to raise the header to its maximum height.
16. If one end of the header does **NOT** fully rise, rephase the lift cylinders as follows:
 - a. Press and hold the HEADER UP switch until both cylinders stop moving.
 - b. Continue to hold the switch for 3–4 seconds to fully phase the cylinders.

NOTE:

It may be necessary to repeat this procedure if there is air in the hydraulic system.



Figure 5.239: Ground Speed Lever

ATTACHING ROTARY DISC HEADER TO WINDROWER

17. To lower the safety props:
 - a. Pull lever (A) outward and rotate it toward the header to lower safety prop (B) onto the cylinder.
 - b. Repeat the previous step for the other safety prop.
 - c. Shut down the engine, and remove the key from the ignition.

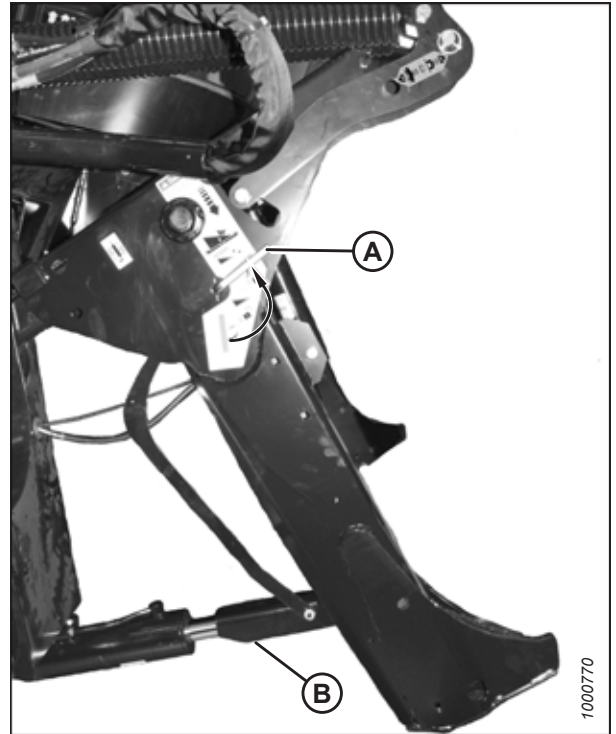

Figure 5.240: Safety Prop

18. Install clevis pin (A) through the support and the windrower foot. Secure the clevis pin with hairpin (B).

IMPORTANT:

Ensure that clevis pin (A) is fully inserted and that the hairpin is installed behind the bracket.

19. Repeat the previous step on the other side of the header.

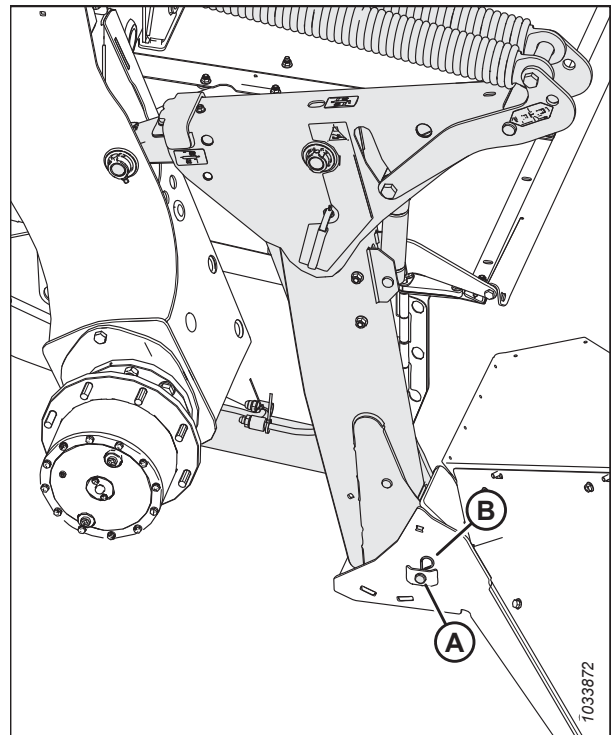

Figure 5.241: Header Support

ATTACHING ROTARY DISC HEADER TO WINDROWER

20. Remove the clevis pin from storage position (B) in the linkage and insert it into hole (A) to engage the float springs. Secure it with the hairpin. Repeat this step on the opposite float linkage.
21. Repeat the previous step for the other float engagement pin.

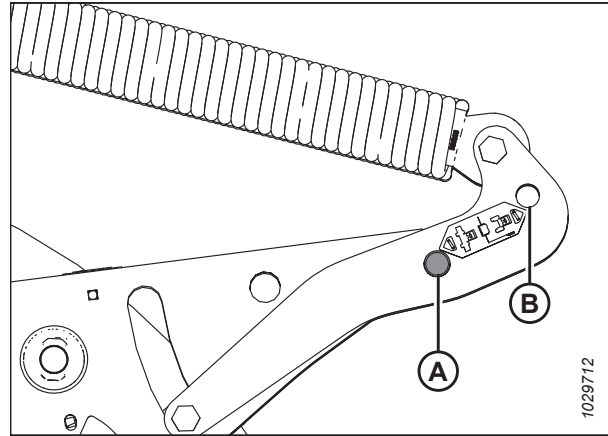

Figure 5.242: Header Float Linkage

22. Disengage the safety prop by turning lever (A) downwards until the lever locks into vertical position.
23. Repeat the previous step to disengage the other safety prop.

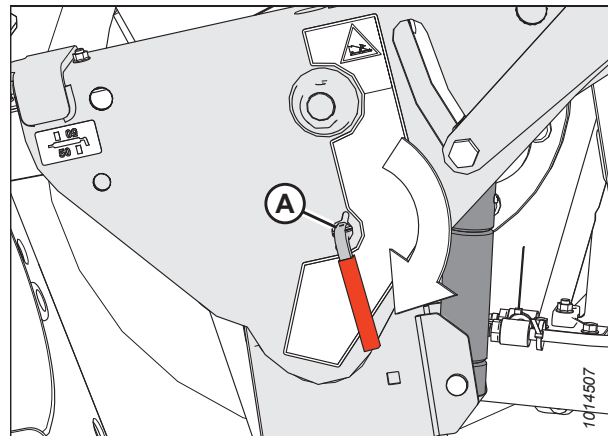

Figure 5.243: Safety Prop

24. Start the engine, and press HEADER DOWN switch (A) on the GSL to fully lower the header.
25. Shut down the engine, and remove the key from the ignition.

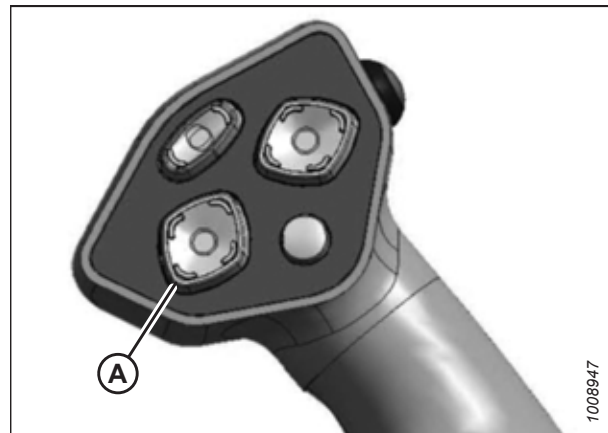

Figure 5.244: Ground Speed Lever

5.10.3 Connecting R2 Series Rotary Disc Header Hydraulics and Electrical – M155E4 SP Windrower

Once the R216 Rotary Disc Header is attached to the M155E4 Self-Propelled Windrower, the hydraulic and electrical connections must be completed.

1. Connect the windrower's hydraulic hoses to the header's. Refer to the illustrations provided for guidance. The callout letters in the first illustration correspond to those in the second; for example, upper pressure hose (A) in the first illustration corresponds to upper pressure hose (A) in the second illustration:

- (A) Upper pressure hose
- (B) Lower pressure hose
- (C) Return hose
- (D) Case drain hose

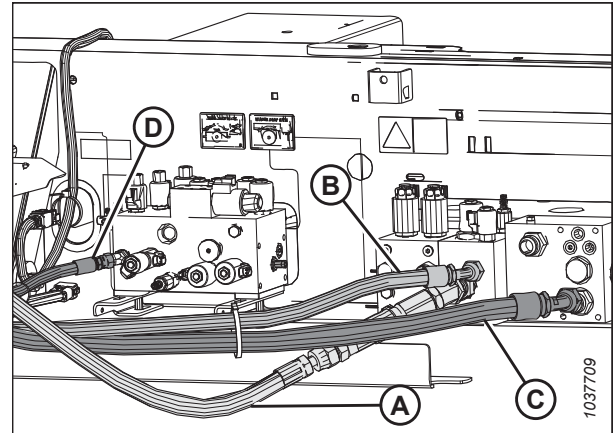

Figure 5.245: Windrower Hydraulic Hoses Connected to Hydraulic Block

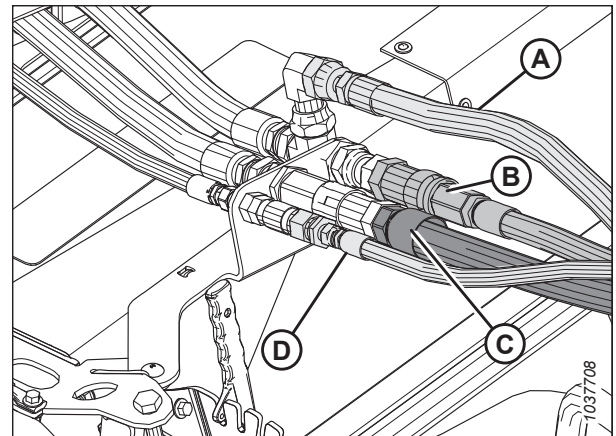

Figure 5.246: Windrower Hydraulic Hoses Connected to Header – View from Rear of Header

ATTACHING ROTARY DISC HEADER TO WINDROWER

2. Locate windrower adapter harness (A) on the windrower's center-link. Remove windrower adapter harness (A) from its storage location on center-link (B).
3. Connect harness (A) to header harness (C).

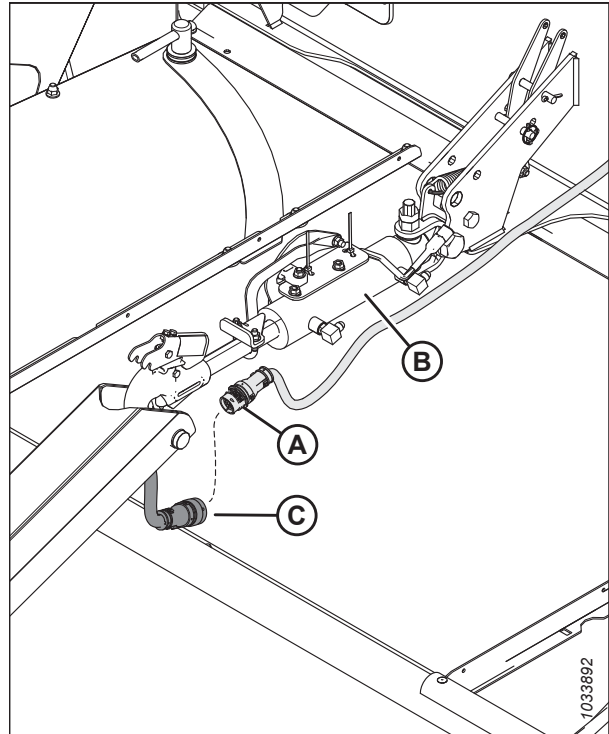

Figure 5.247: Windrower Adapter Harness

NOTE:

When the harness is not in use, secure harness (A) to the center-link tilt cylinder using strap (B).

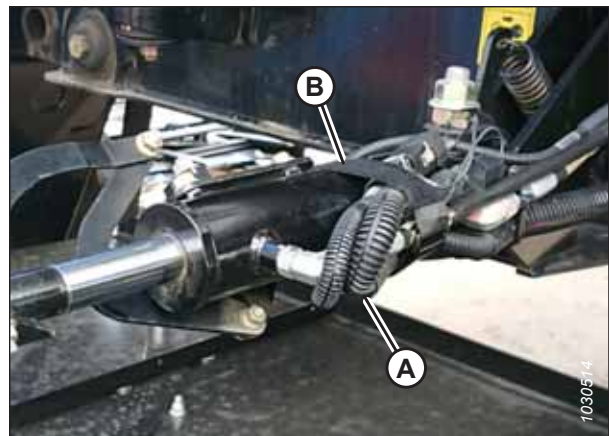

Figure 5.248: Adapter Harness Secured to Center-Link

5.11 Setting the Header Cut Width

The header sends an electrical signal to the windrower to produce a header ID. However, the cut width will always default to the smallest header size available for each header type. Once you connect the R216 Rotary Disc Header to the M205 SP Windrower, the cab display module (CDM) will automatically detect the correct header ID (“DISC” and “0001”) but you need to change the default size of “13.0 FT” to a cut width that will optimize your acre count.

NOTE:

- The header **MUST** be attached to the windrower to perform this procedure. The cab display module (CDM) automatically adjusts its programming for each header.
- Set the header cut width to less than the effective cutting width (16 ft. 2 in.) of the header in order to accurately measure the number of acres cut.

1. Turn the ignition key to RUN, or start the engine.
2. Press PROGRAM (A) and SELECT (C) on the CDM to enter programming mode.
 - WINDROWER SETUP? is displayed on the upper line.
 - NO/YES is displayed on the lower line.
3. Press right arrow (B) to select YES. Press SELECT (C).
 - SET KNIFE SPEED? is displayed.



Figure 5.249: M205 SP Windrower CDM Programming Buttons

4. Press SELECT (D) until HDR CUT WIDTH? 0001 is displayed on the upper line.
 - The previous cutting width is displayed on the lower line.
5. Press left (B) or right (C) arrows to change the header cut width. Press SELECT (D).
6. Press PROGRAM (A) to exit programming mode or press SELECT (D) to proceed to next WINDROWER SETUP action.



Figure 5.250: M205 SP Windrower Header Cut Width

Chapter 6: Unpacking the Curtain

The curtain is installed at the front of the header. It minimizes the risk of thrown objects ejected at high speed from the cutterbar area.

DANGER

To prevent bodily injury or death from the unexpected start-up or fall of a raised machine, always stop the engine, remove the key, and engage the safety props before going under the header for any reason.

DANGER

Ensure that all bystanders have cleared the area.

1. Start the engine.
2. Raise the header fully.
3. Shut down the engine, and remove the key from the ignition.
4. Engage the header safety props. For instructions, refer to:
 - M1 Series and M2 Series Windrowers – [10.3 Engaging and Disengaging Header Safety Props – M1 Series and M2 Series Windrowers, page 196](#)
 - M Series Windrowers – [10.4 Engaging and Disengaging Header Safety Props – M Series Self-Propelled Windrower, page 198](#)
5. Cut five straps (C) securing the cutterbar curtain to the header.
6. Loosen 12 nuts (A) under the rotary disc header top shield 2–3 turns to loosen bumper (B).

IMPORTANT:

Do **NOT** remove nuts (A) from the disc header; the hardware should only be loose enough to remove straps (C).

7. Remove the five straps and discard them.

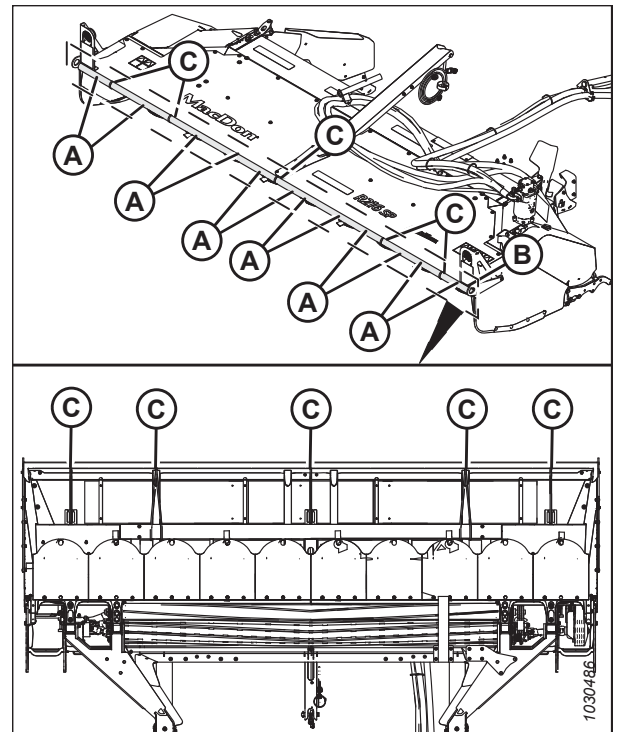

Figure 6.1: Cutterbar Curtain – Standard Header Shown

UNPACKING THE CURTAIN

8. Ensure bumper (A) aligns with the rotary disc header top shield and tighten all loosened hardware (B) to 39 Nm (28.7 lbf-ft) so that bumper (A) and cutterbar curtain (C) are held snugly in place.

WARNING

Ensure that the cutterbar is completely clear of foreign objects. These objects can be ejected with considerable force when the machine is started, which can result in serious injury to bystanders or equipment damage.

9. Check the cutterbar area for debris and foreign objects. Ensure all shipping material is removed.
10. Ensure that the curtain hangs properly and completely encloses the cutterbar area. Minor creases in the curtain will eventually straighten out.

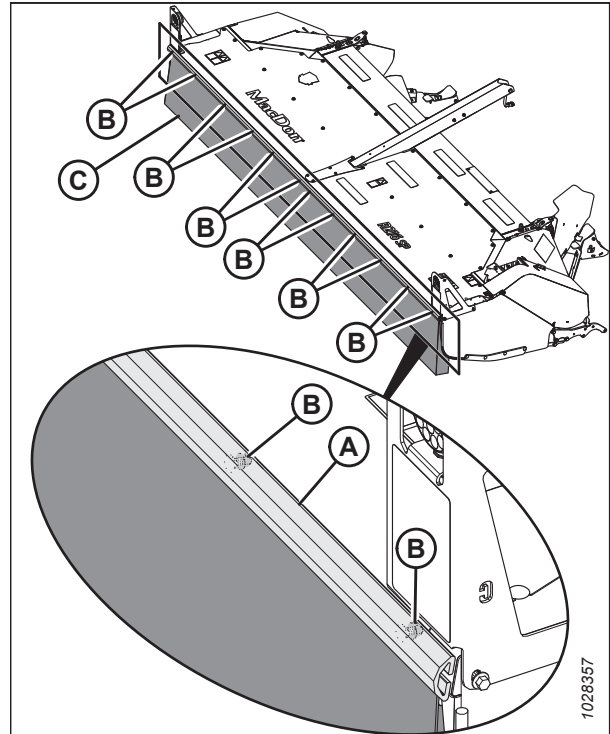

Figure 6.2: Cutterbar Curtain – Standard Header Shown

Chapter 7: Installing Other Options

Install other options (if supplied with the shipment) according to the instructions supplied with each kit.

7.1 Installing Skid Shoes or Gauge Rollers

Skid shoes and gauge rollers are mounted behind the cutterbar and allow the Operator to adjust the cutting height.

To install skid shoes or gauge rollers on the R216 Rotary Disc Header, select the appropriate kit and follow the procedures in the corresponding set of instructions:

Kit Name	Bundle Number
Adjustable Skid Shoes	B7497
Adjustable Gauge Rollers	B7498

7.2 Installing Hydraulic Drive Kit – For Headers Shipped without Hydraulic Drive Only

If the R216 Rotary Disc Header was shipped without hydraulic drive components, a hydraulic drive kit must be installed before the header can be attached to a windrower.

There are a number of hydraulic drive kits: each one configures the header for a different model of windrower. Install the appropriate kit by following the procedures in the corresponding set of instructions:

Windrower Model	Hydraulic Drive Kit
M155	B7310
M155E4	B7310
M205	B6769
M1170	B6845
M1240	B6769
M2170	B6845
M2260 ¹	B6845

1. Only the grass seed version of the R216 Rotary Disc Header can attach to an M2260 Windrower.

7.3 Installing Grass Seed Anti-Shatter Shield Kit – Grass Seed Ready Headers Only

Before the R216 Rotary Disc Header can be used to cut grass seed, the GSS Anti-Shatter Shield kit must be installed on the header. This kit prevents the grass seed from shattering as the crop is cut.

To install the GSS Anti-Shatter Shield kit on an R216 Rotary Disc Header configured for grass seed, use B7222.

Chapter 8: Lubricating Rotary Disc Header

The rotary disc header has been lubricated at the factory. However, you should lubricate the rotary disc header prior to delivery to offset the effects of weather during outside storage and transport.



DANGER

To prevent bodily injury or death from the unexpected startup of the machine, always stop the engine and remove the key from the ignition before leaving the operator's seat for any reason.

8.1 Lubrication Locations – Standard Headers

This topic identifies lubrication locations according to the maintenance schedule for standard headers.

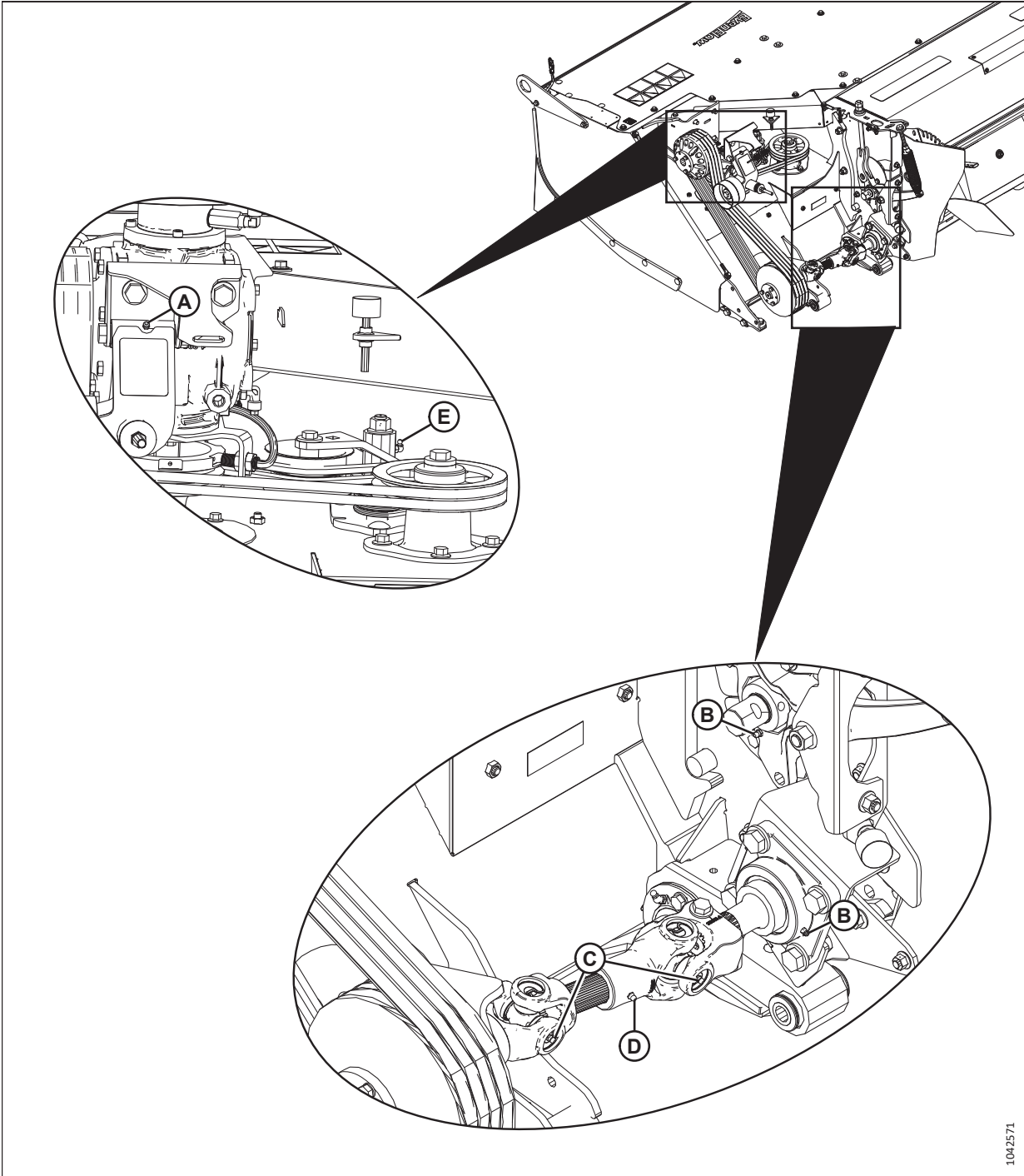

Figure 8.1: Left Lubrication Locations

A - Idler/Tensioner Pivot

D - Slip Joint, Conditioner Driveline²

B - Bearing, Roller Conditioner (Two Places)

E - Tensioner Arm

C - U-Joint, Conditioner Driveline (Two Places)

2. Use high-temperature, extreme-pressure (EP2) performance grease with 10% max molybdenum disulphide (NLGI grade 2) lithium base.

LUBRICATING ROTARY DISC HEADER

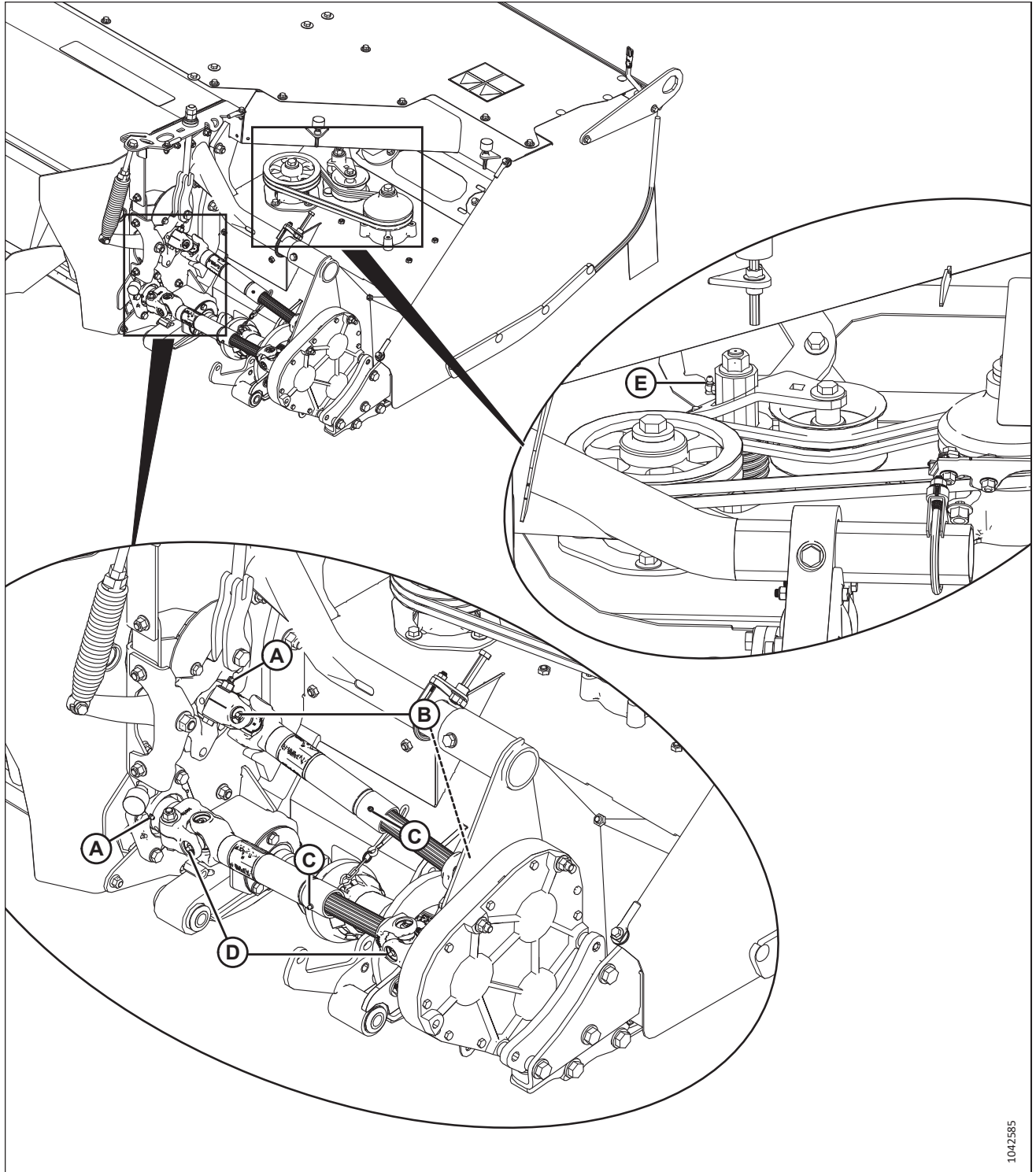

1042585

Figure 8.2: Right Lubrication Locations

A - Bearing, Roller Conditioner (Two Places)
D - U-Joint, Lower Driveline (Two Places)

B - U-Joint, Upper Driveline (Two Places)
E - Idler Pivot

C - Slip Joints, Conditioner Drivelines³

3. Use high-temperature, extreme-pressure (EP2) performance grease with 10% max molybdenum disulphide (NLGI grade 2) lithium base.

8.2 Lubrication Locations – Grass Seed Headers

This topic identifies lubrication locations according to the maintenance schedule for grass seed headers.

Lubricate idler/tensioner locations (A) and (D) every 25 hours. Lubricate grass seed drum locations (B), (C), (E), and (F) every 50 hours. Use high-temperature, extreme-pressure performance grease with 1% max molybdenum disulphide (NLGI grade 2) lithium base for all locations.

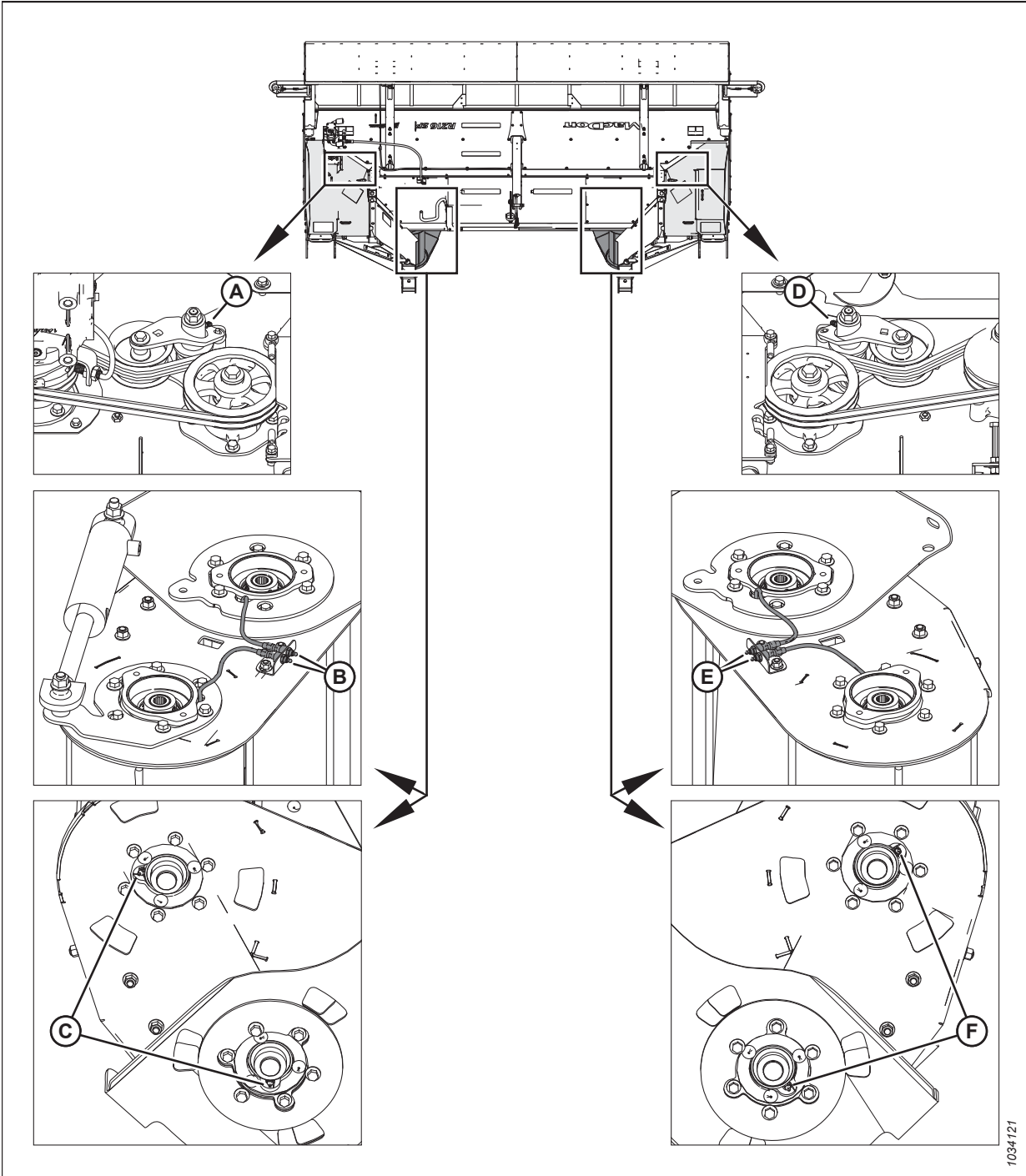

Figure 8.3: Lubrication Locations – Grass Seed

A - Left Idler/Tensioner Pivot
D - Right Idler/Tensioner Pivot

B - Top of Left Grass Seed Drum (Two Places)
E - Top of Right Grass Seed Drum (Two Places)

C - Bottom of Left Grass Seed Drum (Two Places)
F - Bottom of Right Grass Seed Drum (Two Places)

Chapter 9: Performing Predelivery Checks

Perform final checks and adjustments as listed on the Predelivery Checklist (yellow sheet at the back of this instruction) to ensure that the machine is field-ready. Refer to the pages on the Predelivery Checklist for detailed instructions.

The Operator or the Dealer should retain the completed Predelivery Checklist.

9.1 Conditioner Drive Belt – Standard Header

The conditioner drive belt is located inside the left driveshield and is tensioned with a spring tensioner.

9.1.1 Inspecting Conditioner Drive Belt

The tension on the conditioner drive belt is set at the factory and should not require adjustment. The belt, however, should be inspected periodically.

DANGER

To prevent bodily injury or death from the unexpected startup of the machine, always stop the engine and remove the key from the ignition before leaving the operator's seat.

DANGER

Ensure that all bystanders have cleared the area.

1. Start the engine.
2. Lower the header fully.
3. Shut down the engine, and remove the key from the ignition.
4. Open the left driveshield.
5. Inspect drive belt (A). If the belt is cracked or otherwise damaged, replace it.
6. Ensure that jam nut (B) and adjuster nut (C) are tight.

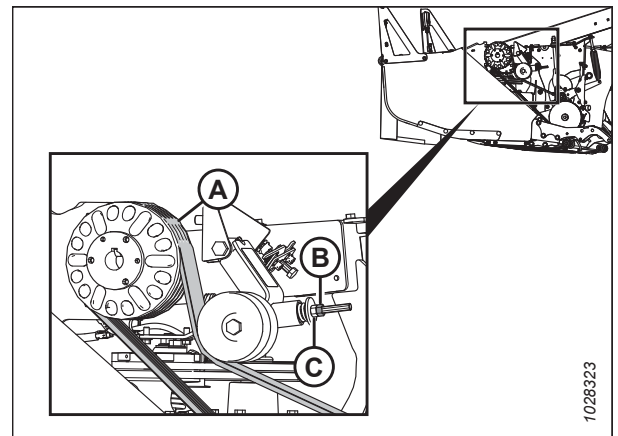

Figure 9.1: Conditioner Drive

PERFORMING PREDELIVERY CHECKS

7. Measure the length of belt tensioner spring (A). Ensure that spring length (B) is 17.5 mm (11/16 in.) in accordance with spring tension decal (C).
8. If the spring length requires adjustment, refer to [9.1.2 Adjusting Conditioner Drive Belt, page 162](#); otherwise, close the driveshield and proceed to [9.2 Header Float, page 164](#).

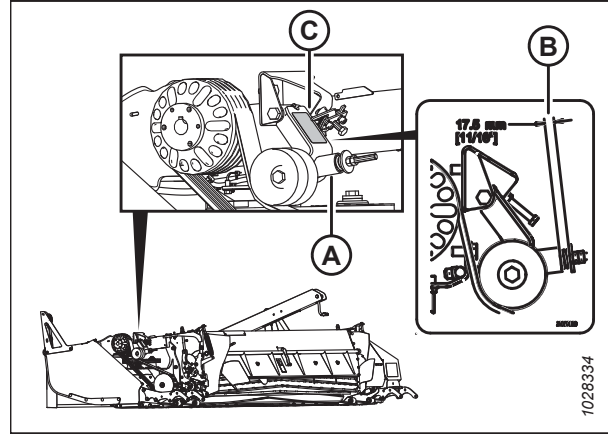

Figure 9.2: Belt Tension Spring

9.1.2 Adjusting Conditioner Drive Belt

In order for the conditioner to turn while the header is operating, the tension of the conditioner drive belt must be properly set.

DANGER

To prevent bodily injury or death from the unexpected startup of the machine, always stop the engine and remove the key from the ignition before leaving the operator's seat.

DANGER

Ensure that all bystanders have cleared the area.

1. Ensure that drive belt (A) is in the grooves on drive pulley (B) and driven pulley (C).

NOTE:

If necessary, loosen the jam nut and the adjuster nut to relieve the tension on the belt.

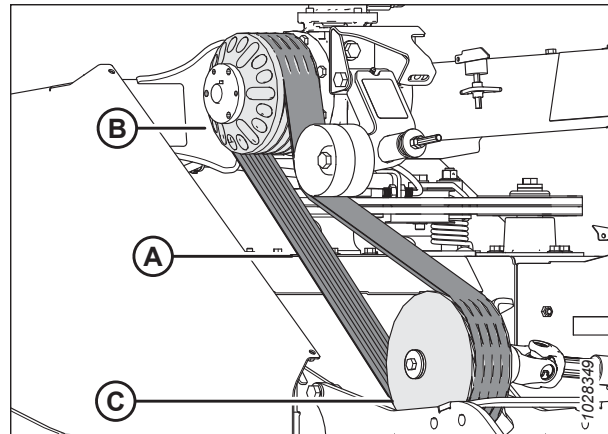

Figure 9.3: Conditioner Drive

PERFORMING PREDELIVERY CHECKS

2. Check the position of bracket (B). Center-to-center distance (C) between pulley (D) and pulley (E) should be 723 mm (28 7/16 in.).
3. If bracket (B) is not set correctly, loosen lock nuts (A) on pulley mount bracket (B), and adjust the position of bracket (B).
4. Torque hardware (A) to 170 Nm (126 lbf-ft). Depending on the model year, the hardware and the torque necessary will vary:
 - For model year 2022 and later, with 5 bolts, torque the hardware to 220 Nm (162 lbf-ft).
 - For model year 2021 and prior, with 3 bolts (class 8.8), torque the hardware to 170 Nm (126 lbf-ft).
 - For model year 2021 and prior, with 3 bolts (class 12.9), torque the hardware to 275 Nm (203 lbf-ft).

For more information on metric bolt specifications, refer to [10.14.1 Metric Bolt Specifications, page 218](#).

5. Slide threaded rod (E) up and backward into the disc speed sensor bracket, then snug the hardware to engage the rod pivot point with the bracket.
6. Measure the length of tensioner spring (C). To ensure that the belt is tensioned correctly, dimension (D) should be set to 17.5 mm (11/16 in.).
7. If the tensioner spring requires adjustment, loosen jam nut (A) by turning it counterclockwise.
8. Turn adjuster nut (B) clockwise to increase the tension on the tensioner spring or turn adjuster nut (B) counterclockwise to decrease the tension on the tensioner spring.
9. Hold adjuster nut (B) in place and tighten jam nut (A) against it by turning the jam nut clockwise.
10. Close the left driveshield.

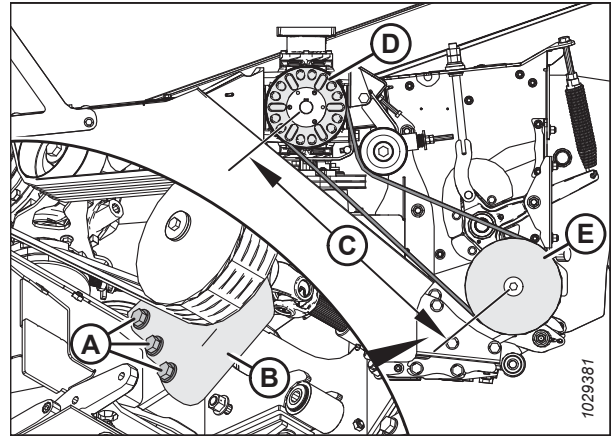

Figure 9.4: Conditioner Drive

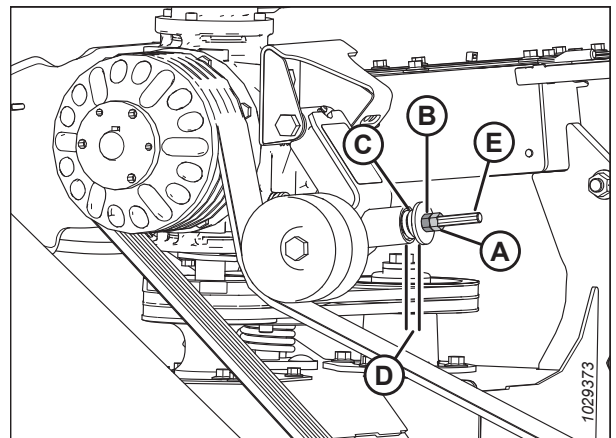

Figure 9.5: Conditioner Drive

9.2 Header Float

The header float feature allows the header to closely follow contours in the ground and respond quickly to sudden changes or obstacles.

9.2.1 Checking Float – M1 Series and M2 Series Windrowers

You can check the header float setting by measuring the force required to lift the header.

DANGER

To prevent bodily injury or death from the unexpected startup of the machine, always stop the engine and remove the key from the ignition before leaving the operator's seat for any reason.

DANGER

Ensure that all bystanders have cleared the area.

1. Start the engine.
2. Use HEADER TILT switches (A) on the ground speed lever (GSL) to set the center-link to the mid-range position.
3. Using HEADER DOWN switch (B), lower the rotary disc header fully. The header lift cylinders will fully retract.
4. Ensure the header is level with the ground with zero tilt.



Figure 9.6: Ground Speed Lever (GSL)

5. Shut down the engine, and remove the key from the ignition.
6. Grasp one end of the header and lift it up. The lifting force should be 426–471 N (95–105 lbf) and should be the same at both ends.
7. Restart the engine, and adjust the float as needed. For instructions on adjusting the float, refer to [9.2.3 Setting Float – M1 Series Windrowers, page 166](#) for M1 Series Windrowers, or [9.2.2 Setting Float – M2 Series Windrowers, page 164](#) for M2 Series Windrowers.

NOTE:

Increasing the float makes the header feel lighter.

9.2.2 Setting Float – M2 Series Windrowers

The float can be set for windrowing with the cutterbar on the ground.

The optimum float setting lets the rotary disc header follow the contour of the terrain.

1. Set the center-link to the mid-range position (5.0 on the HarvestTouch™ Display). For instructions, refer to the windrower operator's manual.

PERFORMING PREDELIVERY CHECKS

- When cutting on the ground, lower the header until the cutterbar is on the ground.

NOTE:

To minimize scooping rocks when operating at the flattest header angle, lower the header skid shoes. For instructions, refer to the header operator's manual.

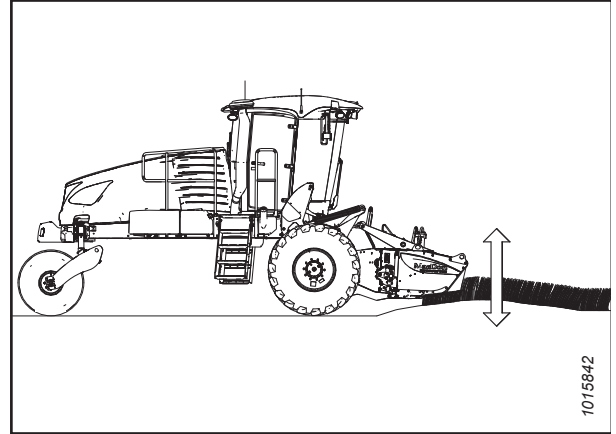

Figure 9.7: Header Float – Cutterbar on Ground

- Press FLOAT SETTINGS icon (A) on the HarvestTouch™ Display to show the float setting page.

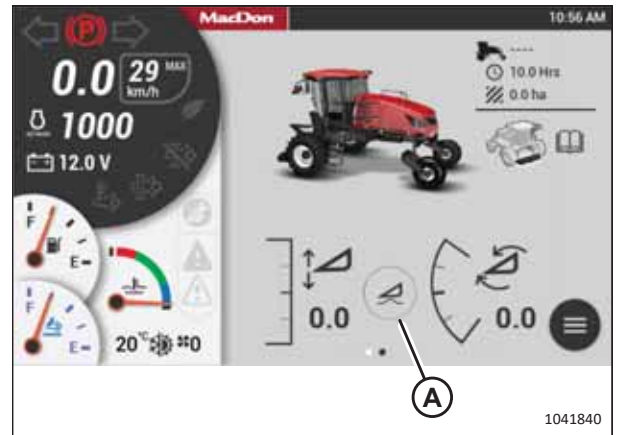

Figure 9.8: HarvestTouch™ Display

- Press arrows (A) to adjust left or right float settings.

NOTE:

Float adjustments of 1.0 (out of 10) change the header weight at the cutterbar by approximately 91 kg (200 lb.). Adjust the float in increments of 0.05 to optimize field performance.

- Press switch (B) to remove or resume the header float.

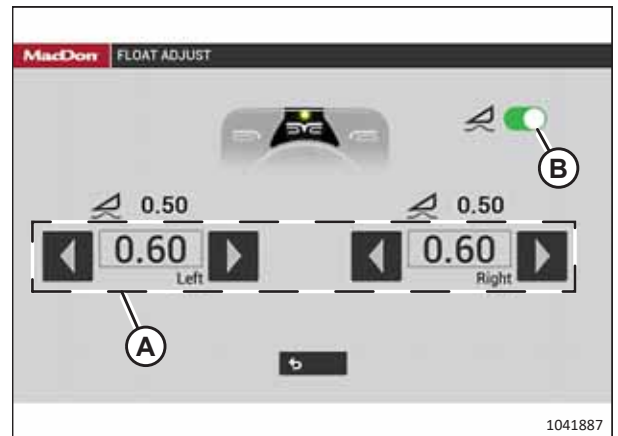

Figure 9.9: HarvestTouch™ Display

9.2.3 Setting Float – M1 Series Windrowers

The float can be set for windrowing with the cutterbar on the ground.

The optimum float setting lets the rotary disc header follow the contour of the terrain.

1. Press rotary scroll knob (A) on the Harvest Performance Tracker (HPT) to display the QuickMenu page.
2. Rotate scroll knob (A) to highlight header float icon (B) and press the scroll knob to select.



Figure 9.10: HPT Run Screen

3. Turn scroll knob (A) to highlight left (B) or right float (C) and press knob (A) to activate the selection.
4. Rotate scroll knob (A) to adjust the float setting and press the knob.

NOTE:

Float adjustments of 1.0 (out of 10) change the header weight at the cutterbar by approximately 91 kg (200 lb.). Adjust the float in increments of 0.05 to optimize field performance.

5. Press soft key 3 (D) to remove or resume the header float.



Figure 9.11: HPT Float Settings

9.2.4 Checking Float – M Series Windrowers

The windrower is equipped with primary (coarse) and secondary (fine) float adjustment systems. The primary adjustment system allows the Operator to move the system's drawbolts to change the tension on the springs in the lift linkages. The secondary adjustment system allows the Operator to use hydraulic cylinders to change the spring tension.



Figure 9.12: Cab Display Module (CDM) Float Adjustment

A - CDM Display

D - Header Tilt Down

B - Left Float Adjustment

E - Header Lower

C - Right Float Adjustment

F - Header Tilt Up

DANGER

To prevent bodily injury or death from the unexpected startup of the machine, always stop the engine and remove the key from the ignition before leaving the operator's seat for any reason.

DANGER

Ensure that all bystanders have cleared the area.

1. Start the engine.
2. Lower the header fully.
3. Using HEADER TILT switches (D) and (F), set the center-link to the mid-range position (5.0 on cab display module [CDM] [A]).
4. Using HEADER DOWN switch (E), lower the header fully until the lift cylinders fully retract.

PERFORMING PREDELIVERY CHECKS

5. Set the left and right float fine adjustments on the CDM to approximately **5.0**:
 - a. Using FLOAT SELECTOR switch (B), push + to increase the float or – to decrease the float on the left side of the header. CDM display (A) will show the selected float setting for the left side (for example: **5.0 L FLOAT R XX.X**).
 - b. Repeat the previous step for the right side of the header float using switch (C). The display will show the float setting for both sides, (for example, **5.0 L FLOAT R 5.0**).
6. Shut down the engine, and remove the key from the ignition.
7. Grasp the end of the header and lift it up. The force to lift the end of the header should be 426–471 N (95–105 lbf) and should be approximately the same at both ends.

9.2.5 Setting Float – M Series Windrowers

The float disc can be preprogrammed for different windrowing conditions.

The Operator may wish to have different float settings available for different harvest conditions. For example, the Operator may wish to have a preset for normal conditions and a preset for rocky conditions.

To configure different float presets:

DANGER

Ensure that all bystanders have cleared the area.

1. Start the engine.
2. Engage the header.
3. Move FLOAT PRESET SWITCH (A) to position 1 (B).

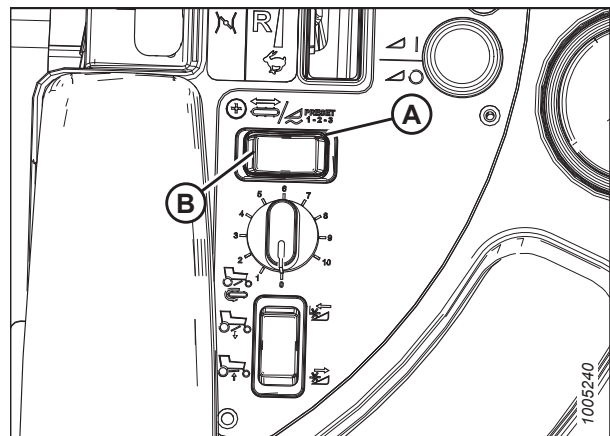

Figure 9.13: Float Preset Switch



Figure 9.14: Cab Display Module (CDM) Float Adjustment

- | | | |
|----------------------|---------------------------|----------------------------|
| A - CDM Display | B - Left Float Adjustment | C - Right Float Adjustment |
| D - Header Tilt Down | E - Header Lower | F - Header Tilt Up |

4. Using HEADER TILT switches (D) and (F), set the center-link to the mid-range position (5.0 on cab display module [CDM] [A]).
5. Using HEADER DOWN switch (E), lower the header fully, so that the lift cylinders are fully retracted.
6. Set the left and right float fine adjustments on the CDM to approximately 5.0:
 - a. Using FLOAT SELECTOR switch (B), push + to increase the float or – to decrease the float on the left side of the header. CDM display (A) will show the selected float setting for the left side (for example: 5.0 L FLOAT R XX.X).
 - b. Repeat the previous step for the right side of the header float using switch (C). The display will show the float setting for both sides, (for example, 5.0 L FLOAT R 5.0).
7. Select a second preset with FLOAT PRESET 2 SWITCH (C).
8. Repeat Step 2, page 168 and Step 3, page 168 to configure a second float preset.
9. Select a third preset with FLOAT PRESET 3 SWITCH (D).
10. Repeat Step 2, page 168 and Step 3, page 168 to configure a third float preset.

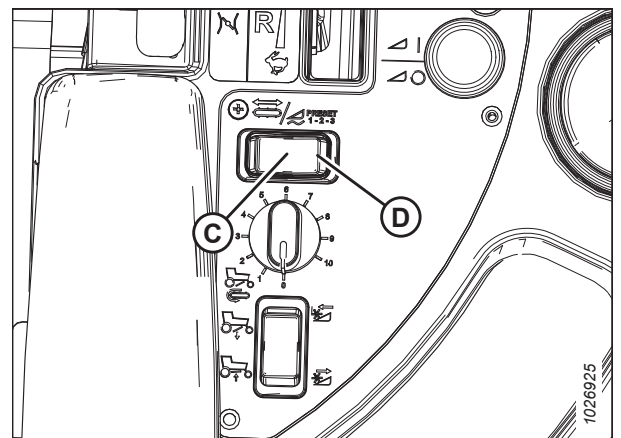

Figure 9.15: Float Preset Switch

PERFORMING PREDELIVERY CHECKS

Adjusting Float Using Drawbolts

DANGER

To prevent bodily injury or death from the unexpected startup of the machine, always stop the engine and remove the key from the ignition before leaving the operator's seat for any reason.

DANGER

Ensure that all bystanders have cleared the area.

1. Start the engine.
2. Using HEADER UP switch (A) on the ground speed lever (GSL), raise the header fully.
3. Shut down the engine, and remove the key from the ignition.
4. Turn drawbolt (A) clockwise to increase the float, or counterclockwise to decrease the float.
5. Recheck the header float. Refer to [9.2.4 Checking Float – M Series Windrowers](#), page 167 for instructions.



Figure 9.16: GSL

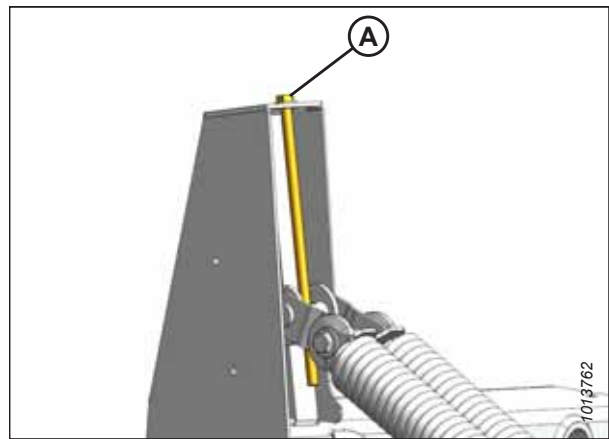

Figure 9.17: Header Float Adjustment

9.3 Activating Grass Seed Option – M2 Series Windrowers

The grass seed (GSS) option must be activated with the HarvestTouch™ Display the first time the header is attached to the windrower.

1. To access the Header Attachments page, press MENU (A).
2. Press SETUP (B), then HEADER (C). The HEADER page opens and lists all of the headers that have been attached to the windrower.

NOTE:

The F4 shortcut button on the operator’s console will also display the HEADER SETUP page.



Figure 9.18: HarvestTouch™ Display

3. Select the header model. In this example, R216 DISC (A) is selected and a list of setup options opens.



Figure 9.19: Header List

4. Select ATTACHMENTS (A).

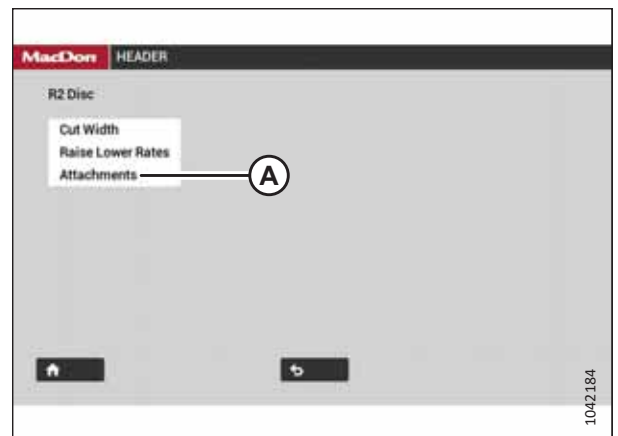

Figure 9.20: Header Setup

PERFORMING PREDELIVERY CHECKS

5. Select GSS switch (A) to activate the grass seed option. The HarvestTouch™ Display, the ground speed lever, and the operator console will now control the grass seed attachment.

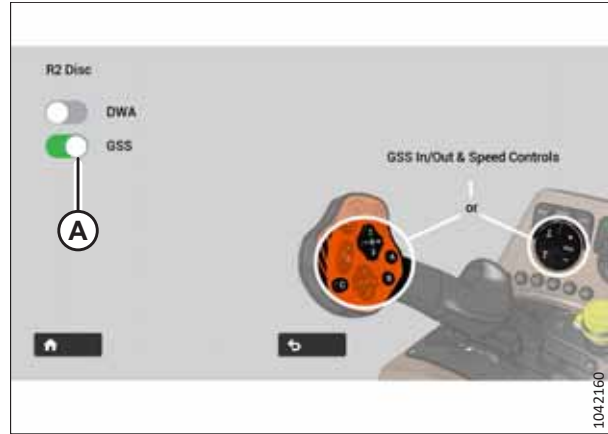

Figure 9.21: Attachments Page

6. When the grass seed option is activated, GSS seed drum SPEED (A), SETTINGS ICON (B), and PRESSURE (B) will appear on header run screen 2.

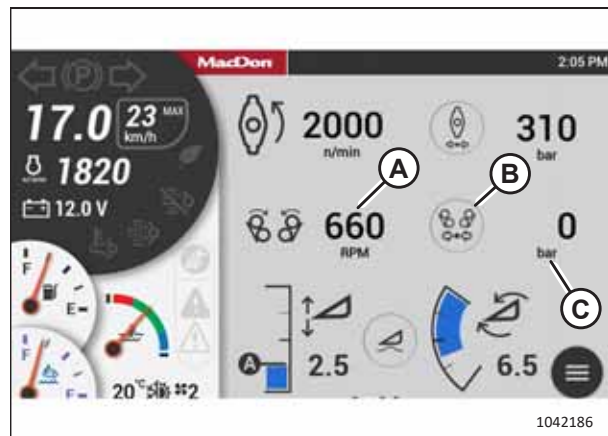

Figure 9.22: Run Screen 2 – Grass Seed Active

9.4 Activating Grass Seed Option – M1 Series Windrowers

The grass seed (GSS) option on the header must be activated the first time it is attached to the windrower.

NOTE:

The windrower requires the software versions (or newer) listed in Table 9.1, page 173 to operate the grass seed header.

Table 9.1 Windrower Software Requirement

Windrower (North America, Export)	Software Version
M1170 (North America, Export) M1240 (North America, Export)	Master Controller: MCAL203587Q or newer
	Harvest Performance Tracker: HPAL203586T or newer

1. Turn the ignition key to ON to activate the Harvest Performance Tracker (HPT).
2. Press soft key 5 (A) to open the main menu or press SHIFT and SELECT on the ground speed lever.

3. Use scroll knob (B) or the ground speed lever (GSL) scroll wheel (not shown) to place red cursor (C) over the icon you want to select.

NOTE:

Using the scroll knob will activate titles which explain each selection.

4. Press scroll knob (B) or the GSL SELECT button (not shown) to select the highlighted icon.

NOTE:

Pressing the corresponding soft key will also select the icon.

5. Scroll down and select HEADER SETUP menu (A).

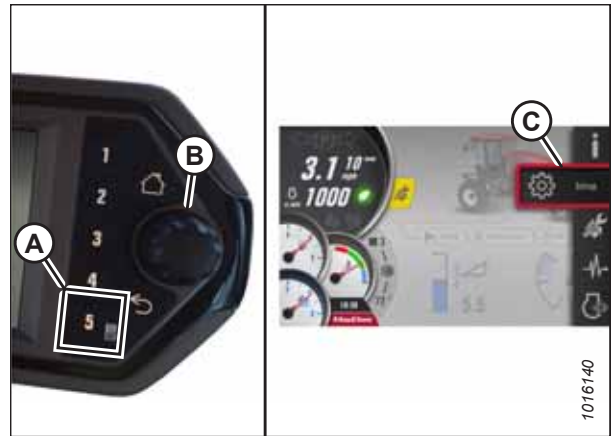

Figure 9.23: Opening the Main Menu



Figure 9.24: Header Setup Screen

PERFORMING PREDELIVERY CHECKS

6. Select R2 DISC (A).



Figure 9.25: Header Setup

7. Select ATTACHMENTS (A).



Figure 9.26: Header Setup

8. Select GRASS SEED (A). The system is now active. The Harvest Performance Tracker (HPT), the ground speed lever, and the operator console can be used to control the grass seed attachment.

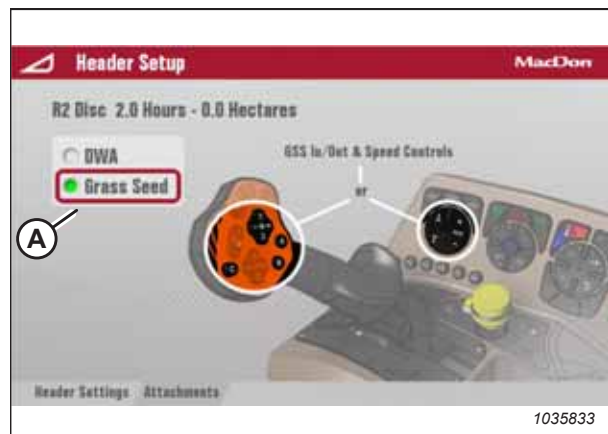

Figure 9.27: Header Setup

PERFORMING PREDELIVERY CHECKS

- Once the grass seed option is activated, Run Screen 2 on the HPT will display speed (A) and pressure (B) of the grass seed drums.

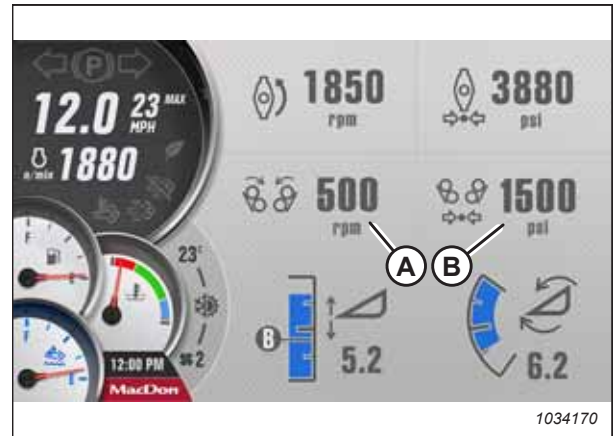

Figure 9.28: Run Screen 2 – Grass Seed Active

- FULLY** extend (A) or retract (C) the anti-shatter shield as follows:
 - Fully extend (A) the shield by pressing and holding F6 (D) on the operator console.
 - Fully retract (C) the shield by pressing and holding F5 (B) on the operator console.

IMPORTANT:

Do **NOT** operate the header in the field with the shield partially extended.

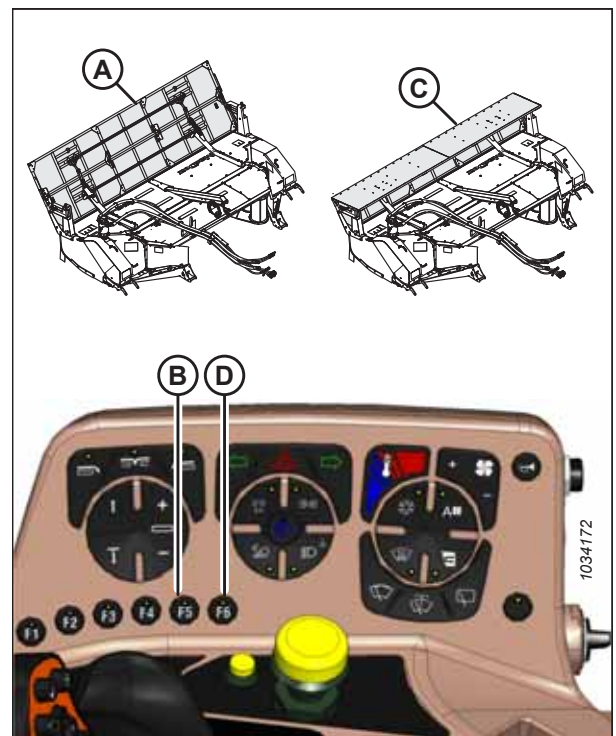

Figure 9.29: Grass Seed Version – Field Position

PERFORMING PREDELIVERY CHECKS

11. Adjust the drum speed and windrow width (drum spacing) as desired using the GSL or the operator's console:

- To widen the windrow, press REEL UP (A) switch on the GSL, or button (A) on the operator's console.
- To narrow the windrow, press REEL DOWN (B) switch on the GSL, or button (B) on the operator's console.
- To increase the drum speed, press switch (C) on the GSL, or button (C) on the operator's console.
- To decrease the drum speed, press switch (D) on the GSL, or button (D) on the operator's console.

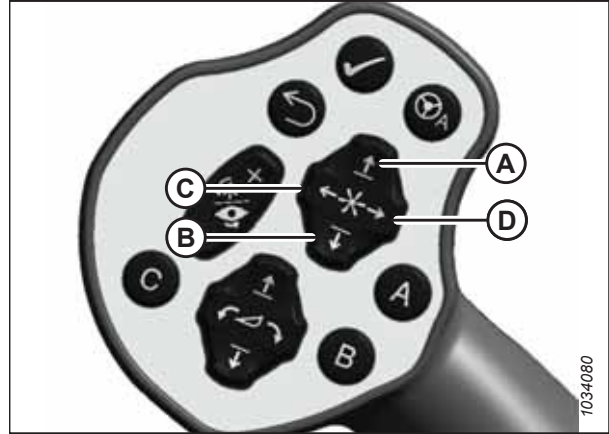

Figure 9.30: GSL – Grass Seed Drum Controls

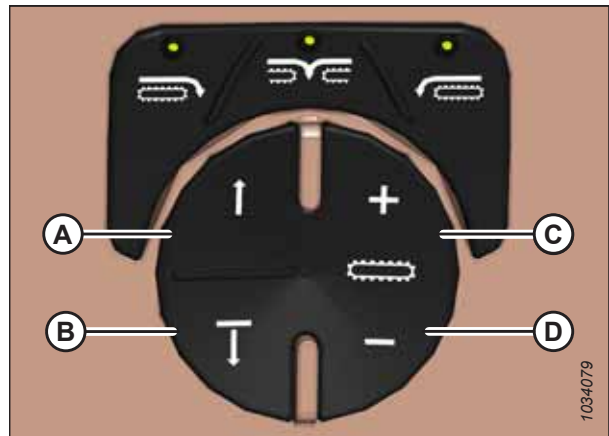

Figure 9.31: Operator's Console – Grass Seed Drum Controls

9.5 Suspended Drum Drive

The suspended drums help feed crop from the ends of the header into the conditioner.

9.5.1 Checking Suspended Drum Drive

The suspended drum drive is set up and tensioned at factory. Ensure the drive belt is properly set and tensioned.

DANGER

To avoid bodily injury or death from unexpected startup of the machine, always stop the engine and remove the key from the ignition before leaving the operator's seat for any reason.

1. Shut down the engine, and remove the key from the ignition.
2. Open the left driveshield. For instructions, refer to [10.10 Opening Driveshields, page 211](#).

3. Inspect tensioner spring (A) and ensure that it is seated properly in notches (B) on bracket (C) and applies tension to both belts (D).

NOTE:

Belts (D) are transparent to better show spring (A) in bracket (C).

4. Torque M16 hex flange nut (E) to 15 Nm (133 lbf·in), and ensure that the tensioner is able to pivot freely.

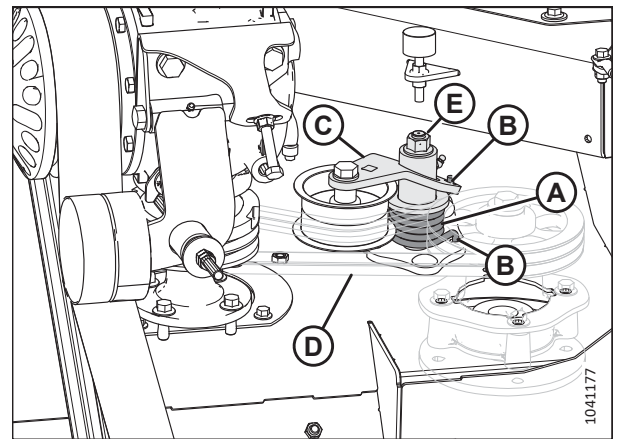

Figure 9.32: Tensioner Spring

5. Inspect the suspended drum belt drive and ensure belts (B) are properly seated on pulleys (A).
6. If necessary, adjust the belts as follows:
 - a. Release belt tension using a 1/2 in. drive ratchet at location (C) to turn the tensioner arm clockwise.
 - b. Install belt (B). Release the tensioner arm to the tension belt.
7. Close the left driveshield.
8. Repeat this procedure on the right side of the header.

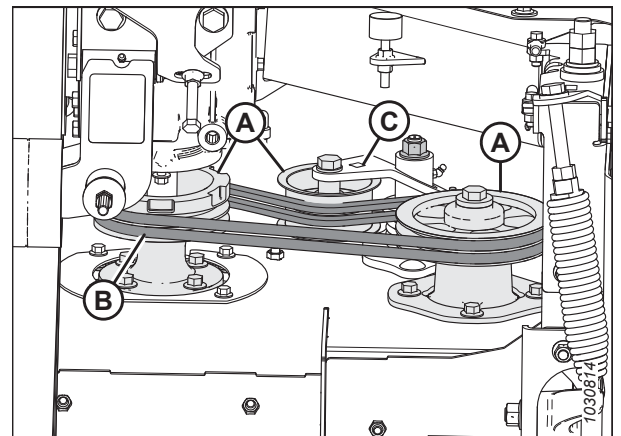

Figure 9.33: Suspended Drum Belt Drive

9.6 Checking and Adding Oil in Conditioner Timing Gearbox – Standard Header

Check the oil in the conditioner timing gearbox to ensure that it was filled to the proper level at the factory.

DANGER

To avoid bodily injury or death from unexpected startup of the machine, always stop the engine and remove the key from the ignition before leaving the operator's seat for any reason.

DANGER

Ensure that all bystanders have cleared the area.

IMPORTANT:

Check the gearbox oil level when the oil is warm. If the oil is cold, idle the machine for approximately 10 minutes before checking the oil.

1. Start the engine.
2. Lower the rotary disc header to the ground and adjust the header angle so that the cutterbar is parallel to the ground.
3. Shut down the engine, and remove the key from the ignition.
4. On the right side of the header, engage lift release latch (A) and pull handle (B) to open outboard driveshield (C).
5. Lift handle (D) to open inboard driveshield (E).

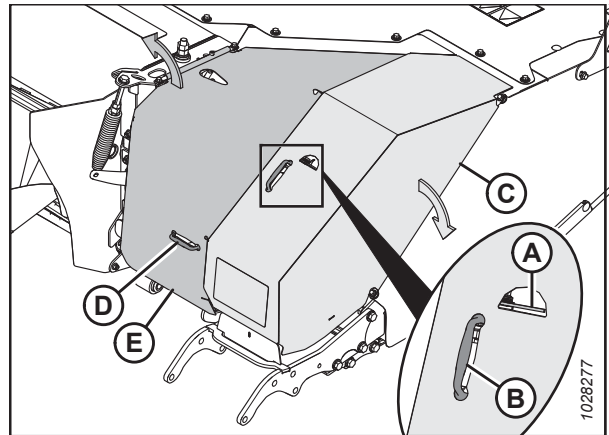

Figure 9.34: Right Driveshield

6. Clean around oil level sight glass (A) and breather (B) on the inboard side of the gearbox.
7. Ensure that the lubricant is level with the top of sight glass (A). If necessary, add lubricant through breather (B).

NOTE:

Refer to the inside back cover for a list of recommended fluids, lubricants, and capacities.

8. Close the right driveshield.

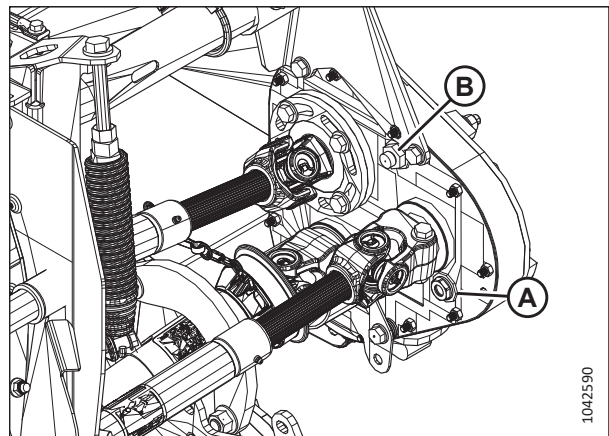

Figure 9.35: Conditioner Timing Gearbox

9.7 Checking and Adding Oil in Header Drive Gearbox

Check the oil in the header drive gearbox to ensure that it was filled to the proper level at the factory.

IMPORTANT:

Check the gearbox oil level when the oil is warm. If the oil is cold, idle the machine for approximately 10 minutes before checking the oil.

DANGER

To prevent bodily injury or death from the unexpected startup of the machine, always stop the engine and remove the key from the ignition before leaving the operator's seat.

1. Open the left driveshield. For instructions, refer to [10.10 Opening Driveshields, page 211](#).
2. Clean the area around check plug (A).
3. Remove check plug (A) with a 13 mm (1/2 in.) socket.
4. Ensure that the lubricant is even with the bottom of the check hole or that it slightly runs out of the check hole.
5. If necessary, remove fill plug (B) and add lubricant to the gearbox through the fill hole until the lubricant runs out of the check hole.

NOTE:

Refer to the inside back cover for a list of recommended lubricants.

6. Reinstall the plug(s) and torque them to 23 Nm (204 lbf·in).
7. Close the left driveshield.

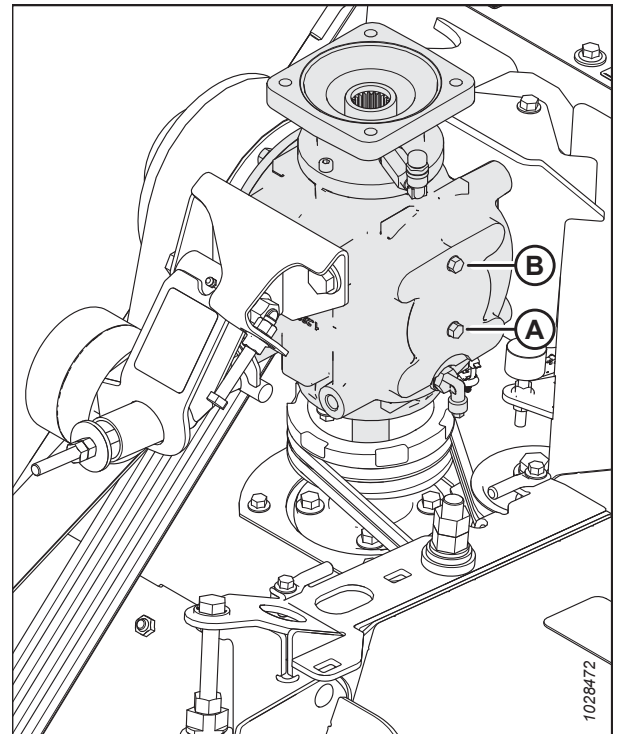

Figure 9.36: Header Drive Gearbox

9.8 Checking and Adding Lubricant in Cutterbar

Ensure that the oil level is correct to maximize the service life of the cutterbar. An incorrect oil level can cause the cutterbar to overheat and damage equipment.

DANGER

To prevent injury or death from the unexpected start-up or fall of a raised machine, always stop the engine and remove the key from the ignition before leaving the operator's seat or making adjustments to the machine. Never work on or beneath an unsupported header. If the header is fully raised, always engage the safety props. If the header is off of the ground but not raised to its full height, place blocks under the header.

DANGER

Ensure that all bystanders have cleared the area.

WARNING

Exercise caution when working around the blades. Blades are sharp and can cause serious injury. Wear gloves when handling blades.

1. Start the engine.
2. Park the machine on level ground.
3. Lower the header onto 250 mm (10 in.) blocks under both ends of the cutterbar.
4. Shut down the engine, and remove the key from the ignition.
5. Open cutterbar curtain (A). For instructions, refer to [10.12 Opening Cutterbar Curtain, page 215](#).

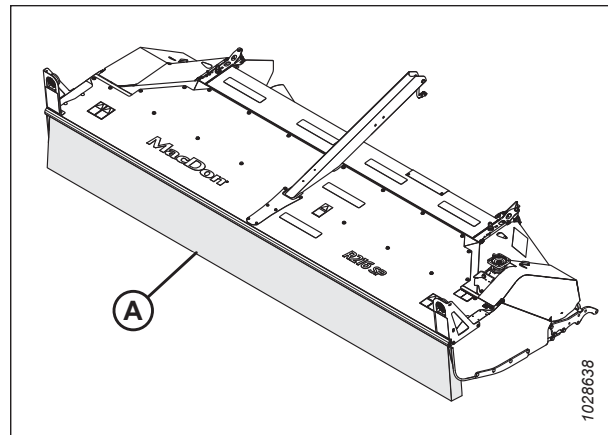

Figure 9.37: Cutterbar Curtain

6. Use spirit level (A) to ensure that the cutterbar is level in both directions. Adjust the header accordingly.

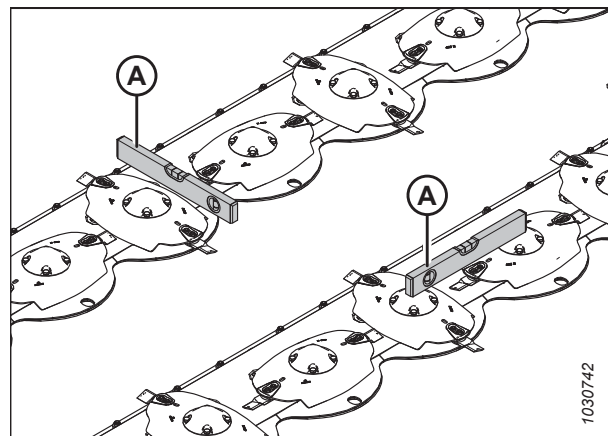

Figure 9.38: Spirit Level on Cutterbar

PERFORMING PREDELIVERY CHECKS

7. Clean the area around plug (A). Place a 5 liter (5.2 US qts) container under plug (A).
8. Use a 17 mm socket to remove plug (A) and gasket (B) from the cutterbar. The oil should be at the level of the inspection plug hole. If additional oil is needed, proceed to the next step. If additional oil is **NOT** needed, proceed to Step 24, page 182.
9. Reinstall the inspection plug.

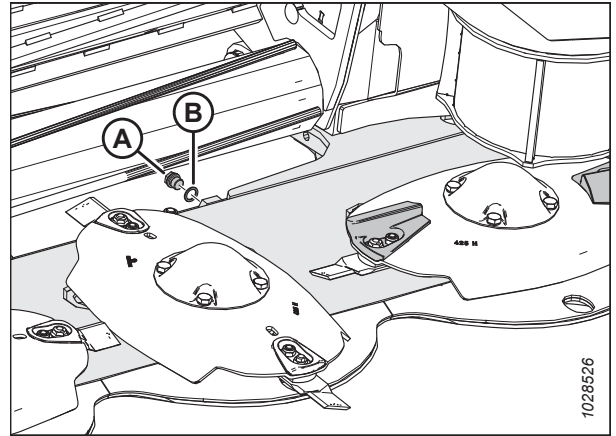

Figure 9.39: Cutterbar Oil Inspection Plug

10. Start the engine and raise the header slightly.
11. Lower the header onto blocks so that the right end is slightly higher than the left end.
12. Shut down the engine, and remove the key from the ignition.
13. Remove plug (A) at the right end of the header.

IMPORTANT:

Do **NOT** remove bolts (B).

14. Add lubricant to the cutterbar as needed.

IMPORTANT:

Do **NOT** overfill the cutterbar. Overfilling the cutterbar with lubricant can cause it to overheat and damage equipment.

NOTE:

For lubrication specifications, refer to the inside back cover.

15. Reinstall plug (A) and torque it to 30 Nm (266 lbf-in).

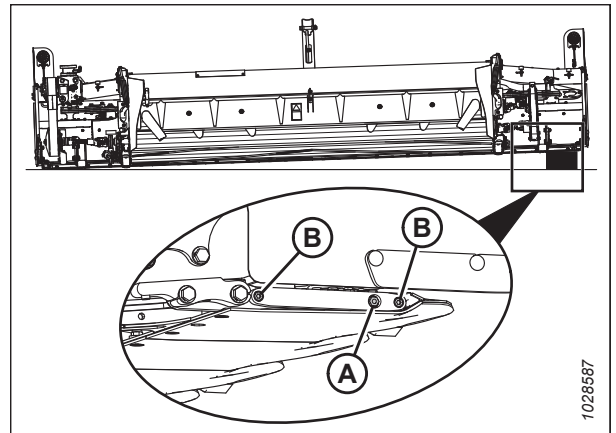

Figure 9.40: Cutterbar Oil Plug

16. Start the engine and raise the header fully.
17. Shut down the engine, and remove the key from the ignition.
18. Engage the windrower lift cylinder safety props.
19. Remove the set of blocks from under the header.
20. Disengage the windrower lift cylinder safety props.
21. Start the engine and lower the header to a level position on the ground.
22. Shut down the engine, and remove the key from the ignition.
23. Recheck the oil level.

PERFORMING PREDELIVERY CHECKS

24. Check gasket (B) for breaks or cracks, and replace it if necessary.
25. Install plug (A) and gasket (B). Tighten the plug securely.

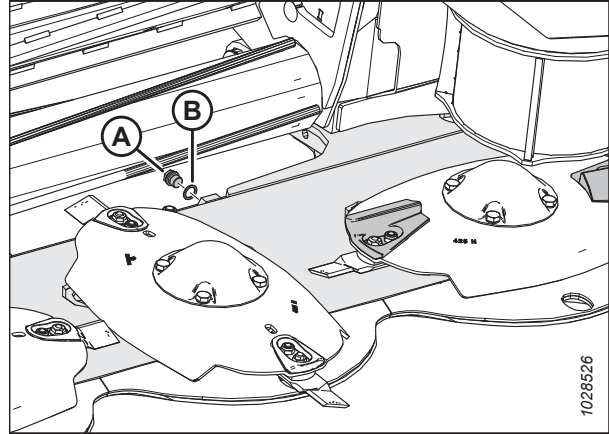

Figure 9.41: Cutterbar Oil Inspection Plug

26. Close cutterbar curtain (A). For instructions, refer to [10.13 Closing Cutterbar Curtain, page 217](#).

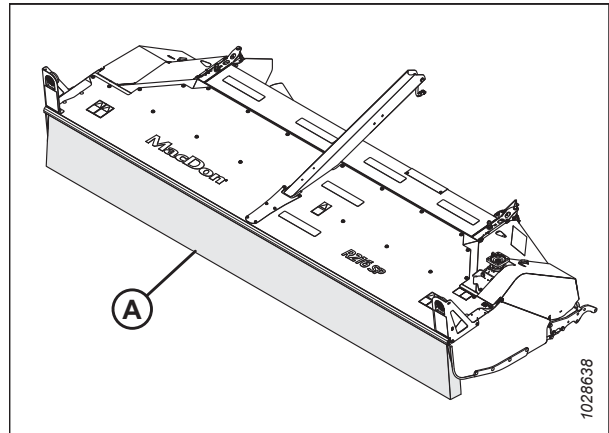

Figure 9.42: Cutterbar Curtain

9.9 Checking Lights

Ensure the hazard/brake lights are attached securely and that they are functioning properly.

1. Ensure that light brackets (A) are undamaged and that they are securely installed.

DANGER

Ensure that all bystanders have cleared the area.

2. Start the engine.
3. Check the operation of hazard lights (B) during machine run-up.
4. Shut down the engine, and remove the key from the ignition.

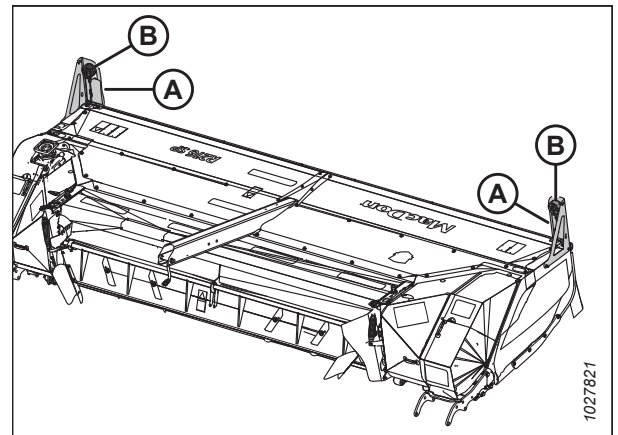

Figure 9.43: Lights on Standard Header

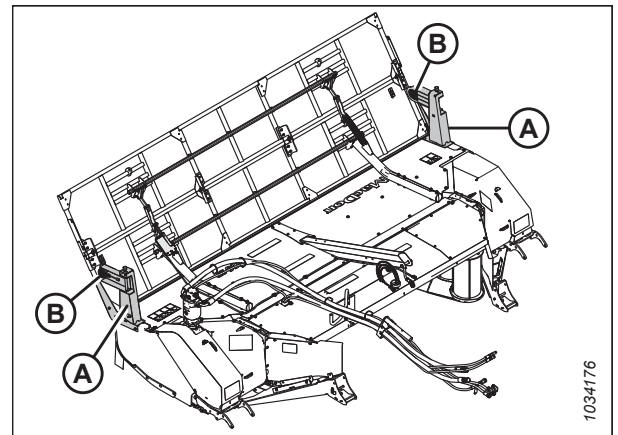

Figure 9.44: Lights on Header with Grass Seed Option

9.10 Checking Manual Storage Case

The manual storage case safely stores documents for quick reference on and off the field.

1. Ensure the following documents are in manual storage case (A):

- R216 Rotary Disc Header Operator's Manual
- R216 Rotary Disc Header Parts Catalog
- R216 Rotary Disc Header Quick Card

On standard headers, manual case (A) is located on the left fixed deflector.

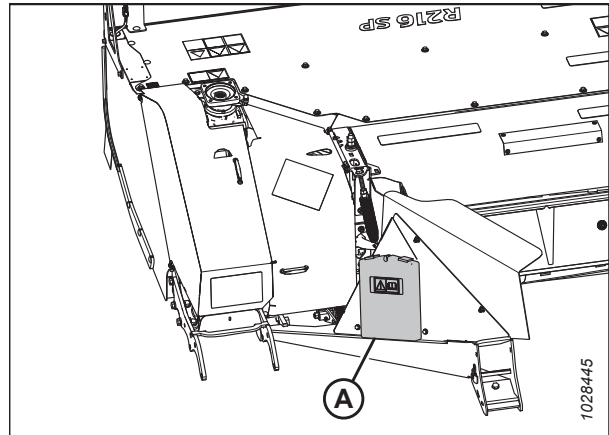

Figure 9.45: Manual Case on Standard Header

On headers with the grass seed option installed, manual case (A) is located inside right driveshield (B). To open the right driveshield, refer to [10.10 Opening Driveshields, page 211](#).

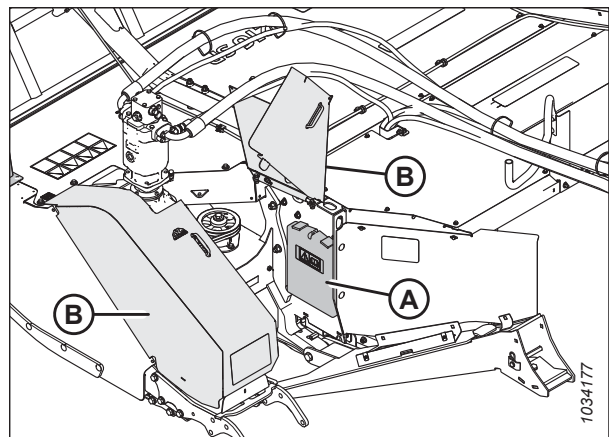

Figure 9.46: Manual Case on Header with Grass Seed Option

9.11 Checking Parts in Storage Location

R2 Series Rotary Disc Headers are shipped with a disc timing tool and a Safecut spindle nut wrench stored on the panel at the right end of the header. Grass Seed (GSS) headers also have two disc feed plates and four support angles stored with the timing tool and wrench.

1. Open driveshields (A) at the right end of the header. For instructions, refer to [10.10 Opening Driveshields, page 211](#).

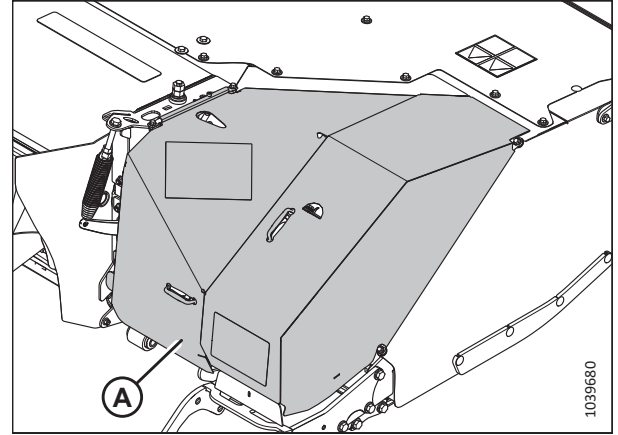

Figure 9.47: Right Driveshields

2. **Standard header:** Confirm timing tool (A) and spindle nut wrench (B) are stored on the header panel.

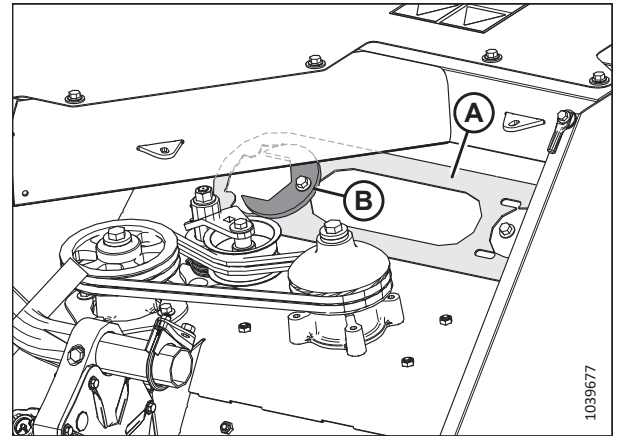

Figure 9.48: Parts in Storage – Standard Header

3. **Grass seed ready header:** Confirm timing tool (A), spindle nut wrench (B), two feed plates (C), and four support angles (D) are stored on the header panel.

NOTE:

Grass seed ready headers are shipped with a total of four feed plates—two standard feed plates and two extended feed plates. Two feed plates are shipped pre-installed on the cutterbar from the factory, and two feed plates are shipped in the storage location. Standard feed plates (C) are shown in the illustration.

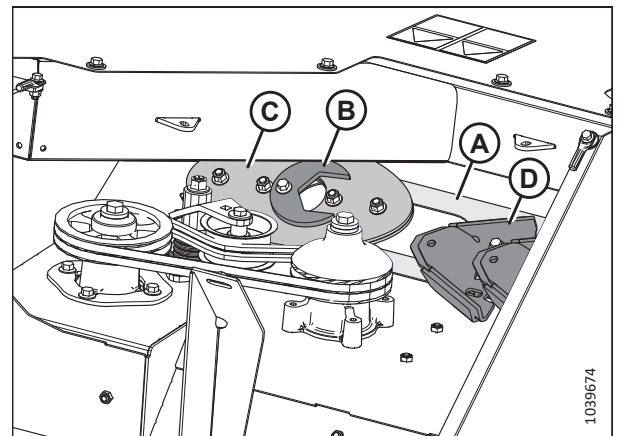

Figure 9.49: Parts in Storage – Grass Seed Ready Header

9.12 Running up Header

Run up the header to ensure that the machine is ready to deliver to the Customer.

WARNING

- Ensure that bystanders remain at least 100 m (330 ft.) from the header while it is operating. Stones and other objects can be ejected from the header with great force.
- Inspect the cutterbar area carefully for loose hardware. These objects can be ejected with great force when the header is engaged, resulting in serious injury or damage.
- The cutterbar curtain mitigates the damage potential of thrown objects. Always keep the curtain down when operating the header. Replace the curtain if it becomes worn or is damaged.

DANGER

Before investigating an unusual sound or attempting to correct a problem, shut off the engine, engage the parking brake, and remove the key.

DANGER

Ensure that all bystanders have cleared the area.

NOTE:

A higher engine rpm may be required to engage the header. Do **NOT** exceed 1800 rpm.

1. Start the engine.
2. Set the header 152–305 mm (6–12 in.) above the ground and adjust the center-link to mid-position.
3. Run the machine slowly for 5 minutes, and watch and listen **FROM THE OPERATOR'S SEAT** for binding or interfering parts.
4. Run the machine at operating speed for 15 minutes. Listen for any unusual sounds or abnormal vibration.
5. Perform the run-up check as listed on the Predelivery Checklist (the yellow sheet inside the back cover of this instruction) to ensure that the machine is field-ready.
6. Shut down the engine, and remove the key from the ignition.
7. Retain the Predelivery Checklist and this instruction for future reference.

Chapter 10: Reference

Additional information and commonly repeated procedures are included in the reference chapter.

10.1 Starting Engine – M1 Series and M2 Series Windrowers

Once the other predelivery checks have been completed, the engine can be started. The windrower's computer will allow the engine to be started only when certain safety conditions have been met.



DANGER

- Start the engine only when the windrower is in a well-ventilated space.
- The windrower is equipped with safety devices which allow the engine to start only when the ground speed lever (GSL) is in PARK, the steering wheel is locked in the PARK position, and the HEADER ENGAGE switch is in the OFF position. Under NO circumstances are these devices to be deliberately rewired or adjusted so that the engine can be started when the GSL is out of the NEUTRAL position.
- Do NOT start the engine by creating a short across the starter or the starter relay terminals. If the normal starting circuitry is bypassed, the machine can start while the drive is engaged and potentially start moving.
- Do NOT start the engine from any other position except the operator's seat.
- Do NOT start the engine while someone is under or near the machine.

IMPORTANT:

Do NOT tow the machine to start the engine. This will damage the hydrostatic drives.

NOTE:

When the Harvest Performance Tracker (HPT) or the HarvestTouch™ Display receives a wake-up signal, the display wakes up from sleep mode and closes the battery disconnect relay. The display enters a boot-up sequence which takes approximately 40 seconds. The following items trigger a wake-up signal for the console:

- Key switch ignition or accessory positions
- Cab door switch
- Horn button
- Hazards button
- Field lights button
- Clearance lights button
- Road lights button
- High beam button

REFERENCE

To start the windrower's engine, follow this procedure:

1. Ensure that engine exhaust pipe (A) is not covered or obstructed.



Figure 10.1: Engine Exhaust

2. Ensure that cab-forward or engine-forward directional lock (A) at the base of the steering column is engaged.

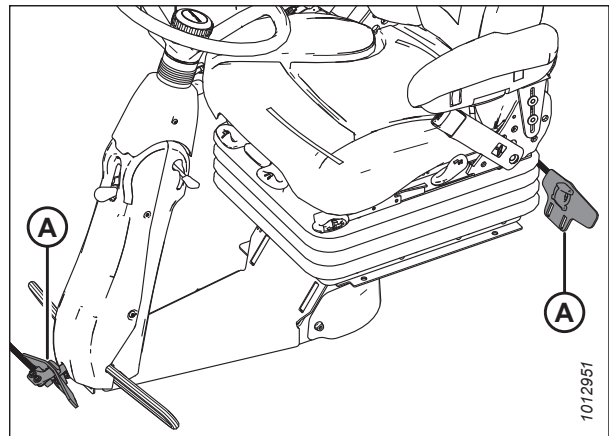

Figure 10.2: Direction Locks

REFERENCE

3. Move ground speed lever GSL (A) into PARK (C).
4. Turn the steering wheel until it locks.

IMPORTANT:

Do **NOT** attempt to force the wheel out of the locked position or the steering system may become damaged.

NOTE:

The steering wheel will be able to move slightly when it is in the locked position.

5. Fasten your seat belt.
6. Push HEADER ENGAGE switch (B) to ensure it is in the OFF position.
7. For M1 Series Windrowers, proceed to Step [8, page 190](#).
For M2 Series Windrowers, proceed to Step [12, page 191](#).

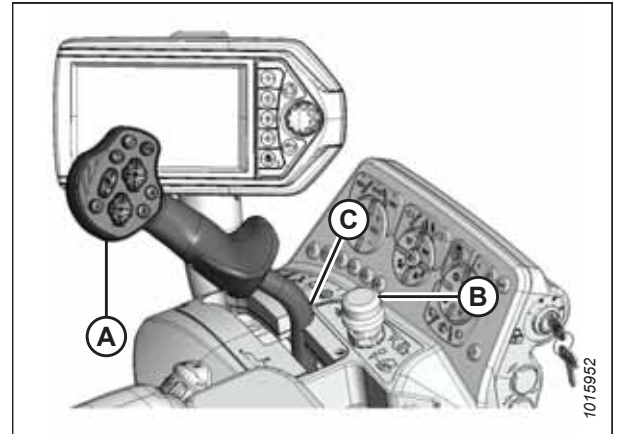

Figure 10.3: Operator Controls – M1 Series Windrower

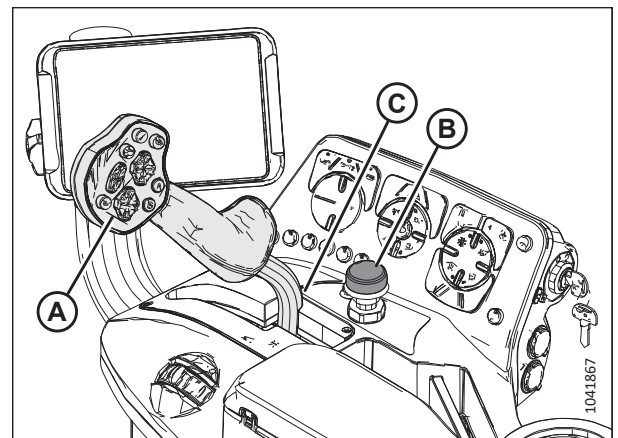

Figure 10.4: Operator Controls – M2 Series Windrower

REFERENCE

M1 Series Windrowers:

8. Press HORN button (E) three times.
9. Turn IGNITION switch (A) to the ON position. Harvest Performance Tracker (HPT) display (B) will light up. Wait for WAIT TO START (WTS) symbol (C) to disappear.
10. Ensure that red PARK symbol light (D) is ON and that there are no error messages on the screen.

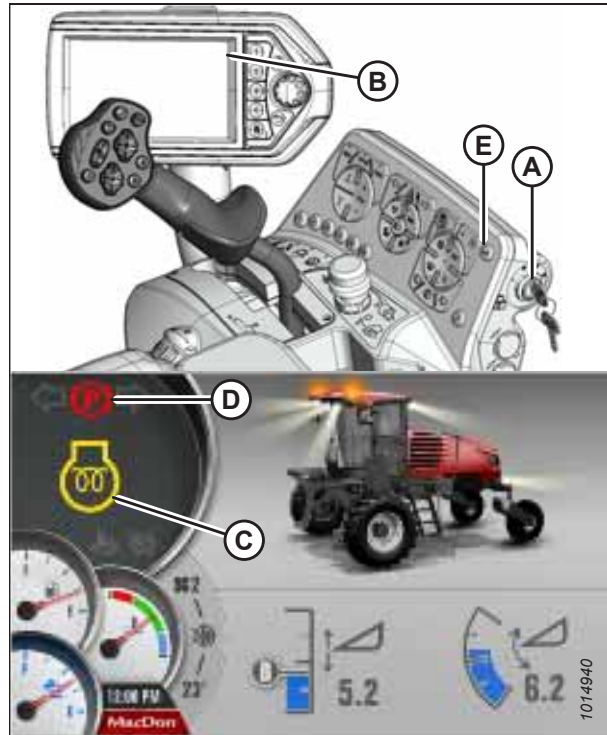

Figure 10.5: Console and HPT Run Screen

11. Turn the IGNITION switch to crank position (A).

IMPORTANT:

Do **NOT** move the GSL out of PARK until the hydraulic oil temperature is at least 32°C (90°F). The hydraulic oil temperature can be viewed on Run Screen 4 on the Harvest Performance Tracker (HPT) display.

IMPORTANT:

- Do **NOT** operate the starter for longer than 15 seconds at a time.
- If the engine does not start, wait at least 2 minutes before you attempt to start the engine again.
- If the engine is cranked for longer than 30 seconds in a 2-minute period, the windrower's computer will lock the starter circuit, and a flashing WTS symbol will appear on the display. Wait for the WTS symbol to stop flashing before attempting to crank the engine again.
- If the engine still does not start, refer to the windrower operator's manual.

NOTE:

When the engine is running and the header is not engaged, the HPT will display header disengaged page (B).



Figure 10.6: HPT Header Disengaged Screen

M2 Series Windrowers:

12. Press HORN button (A) three times.
13. Turn IGNITION switch (B) to the ON position. HarvestTouch™ Display (C) will light up. Wait for WAIT TO START (WTS) symbol (D) to disappear.

IMPORTANT:

Over-crank protection symbol (E) will appear if the starter has been disabled due to overheating.

14. Ensure that red PARK symbol light (F) is ON and that there are no error messages on the screen.

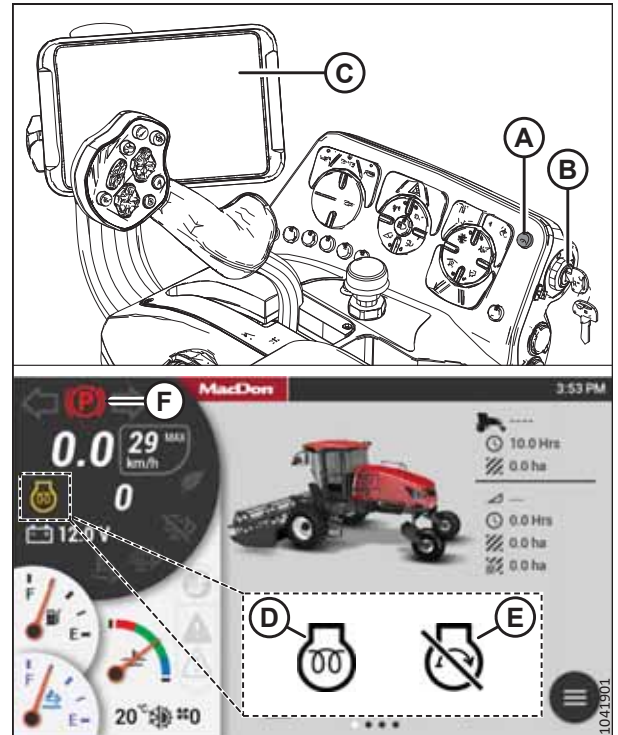

Figure 10.7: Console and HarvestTouch™ Display

15. Turn the IGNITION switch to crank position (A).

IMPORTANT:

Do **NOT** move the GSL out of PARK until the hydraulic oil temperature is at least 32°C (90°F). To check the hydraulic oil temperature, swipe right on home page area (B) until the page displays hydraulic oil temperature (C).

IMPORTANT:

- Do **NOT** operate the starter for longer than 15 seconds at a time.
- If the engine does not start, wait at least 2 minutes before you attempt to start the engine again.
- If the engine is cranked for longer than 30 seconds in a 2-minute period, the windrower's computer will lock the starter circuit, and the over-crank protection symbol will appear on the display. Wait for the over-crank protection symbol to disappear before attempting to crank the engine again.
- If the engine still does not start, refer to the windrower operator's manual.

NOTE:

When the engine is running and the header is not engaged, the HarvestTouch™ Display will show header disengaged page (B).

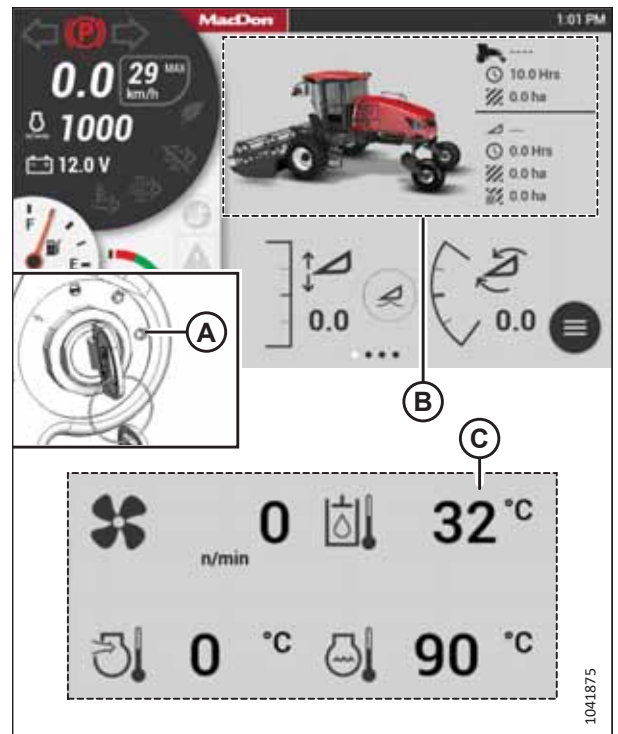

Figure 10.8: HarvestTouch™ Display

REFERENCE

NOTE:

If the engine is started when the ambient temperature is below 5°C (40°F), the engine will cycle through a period during which it will sound as though it is struggling to stay running. This is the engine's warm-up mode. The throttle will be unresponsive while the engine is in warm-up mode. Warm-up mode lasts between 30 seconds and 3 minutes, depending on the ambient temperature. The throttle will become active after the engine has stabilized and is idling normally. Do **NOT** operate the engine above 1500 rpm until the engine temperature gauge is above blue range (A).



Figure 10.9: HPT No Header Screen

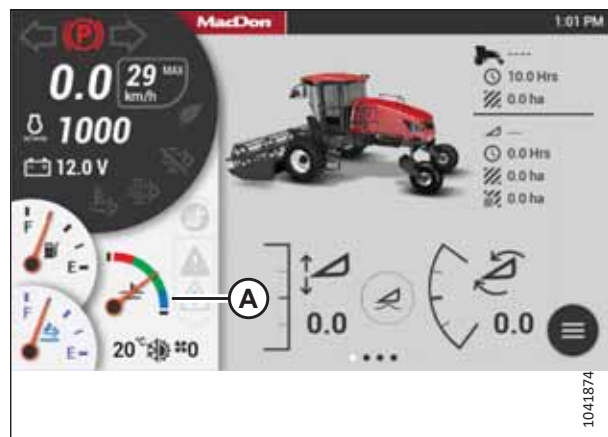

Figure 10.10: HarvestTouch™ Display

10.2 Starting Engine – M Series Windrower

To ensure its service life, start the windrower's engine by following the provided procedure.

DANGER

- This machine has safety devices which allow the engine to start only when the ground speed lever is in the N-DETENT position, the steering wheel is locked in the NEUTRAL position, and the header drive switch is in the OFF position. Under no circumstances are these devices to be deliberately rewired or misadjusted so that the engine can be started with the controls out of the NEUTRAL position.
- Do NOT start the engine by shorting across the starter or starter relay terminals. The windrower will start and might be able to move if the drive is engaged.
- Start the engine only from the operator's seat with the controls in the NEUTRAL position. NEVER start the engine while standing on the ground. Never try to start the engine with someone under or near the windrower.
- Before starting the engine, ensure that there is plenty of ventilation; the exhaust from the engine is dangerous to bystanders when emitted in an unventilated environment.

WARNING

If the starter is able to engage when the steering wheel is unlocked, or when the ground speed lever is out of the NEUTRAL position, or when the header clutch is engaged, DO NOT ATTEMPT TO OPERATE THE WINDROWER. Contact your Dealer immediately for more information.

IMPORTANT:

Do NOT tow the machine to start the engine; this will damage the hydrostatic drives.

1. Main battery disconnect switch (A) is located on the right frame rail, behind the maintenance platform, and can be accessed by moving the platform. Ensure that the switch is in the POWER ON position.

WARNING

Before starting the engine, fasten your seat belt and ensure that the trainer's seat belt is used if the seat is occupied.

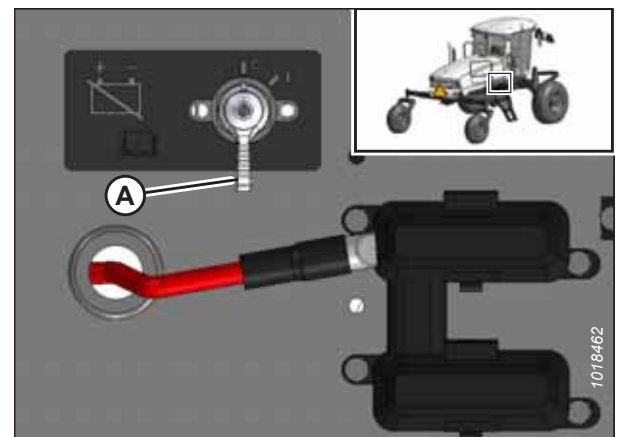

Figure 10.11: Battery Disconnect Switch

REFERENCE

2. Ensure that lock (A) at the base of the steering column is engaged in either the cab-forward or the engine-forward position.
3. Move ground speed lever (GSL) (B) into the N-DETENT position.

4. Turn the steering wheel until it locks.

IMPORTANT:

Do **NOT** attempt to force the wheel out of the locked position; damage to the traction system may occur.

NOTE:

It may be possible to move the steering wheel slightly in the locked position.



Figure 10.12: Operator Controls

5. Fasten your seat belt.
6. Push HEADER DRIVE switch (C) to ensure it is OFF.

DANGER

Ensure that all bystanders have cleared the area.

7. Set throttle (A) to the START position (fully back).
8. Sound the horn three times.
9. Turn ignition key (B) to the RUN position. A single loud tone will sound, the engine warning lights will light up as the ignition self-test is performed, and the cab display module (CDM) will display the messages HEADER DISENGAGED and IN PARK.
10. Turn ignition key (B) to the START position until the engine starts, then release the key. The CDM will display programmed header data for five seconds (if a header is attached to the windrower), and then will resume displaying whatever was previously displayed.



Figure 10.13: Operator Console

IMPORTANT:

The windrower's gauges and instruments provide important information about the windrower's operating status. Familiarize yourself with the gauges; monitor them carefully during when starting the windrower. Refer to the windrower operator's manual for more information.

IMPORTANT:

- Do **NOT** operate the starter for longer than 15 seconds at a time.
- If the engine does not start, wait at least 2 minutes before trying to start the engine again.
- After the third unsuccessful attempt to start the engine, allow the solenoid to cool for 10 minutes before trying again. If the engine still does not start, refer to the windrower operator's manual.
- Do **NOT** operate the engine above 1500 rpm until the engine temperature gauge indicates that the engine coolant temperature is above 40°C (100°F).

REFERENCE

NOTE:

When the ambient temperature is below 5°C (40°F), follow the normal starting procedure. The engine will cycle through a period where it appears to labor until the engine warms up. The throttle will be unresponsive during this time, because the engine is now in WARM UP mode. This mode will last from 30 seconds to 3 minutes, depending on the ambient temperature. After the engine has stabilized and is idling normally, the throttle will become active again.

NOTE:

Before taking the GSL out of the N-DETENT position, warm the hydraulic oil up to 32°C (90°F).

10.3 Engaging and Disengaging Header Safety Props – M1 Series and M2 Series Windrowers

The safety props are located on both of the header lift cylinders on the windrower. Engage the props any time you are going to work on or around a raised header. When engaged, the safety props prevent a header from dropping suddenly if the lift system hydraulics lose pressure.

DANGER

To prevent bodily injury or death from the unexpected start-up or fall of a raised machine, always stop the engine and remove the key before leaving the operator's seat, and always engage the safety props before going under the machine for any reason.

DANGER

Ensure that all bystanders have cleared the area.

1. Start the engine.
2. Press HEADER UP switch (A) on the ground speed lever (GSL) to raise the header to its maximum height.

NOTE:

If one end of the header does **NOT** fully rise, rephase the lift cylinders as follows:

- a. Press and hold HEADER UP switch (A) until both cylinders stop moving.
 - b. Continue to hold the switch for 3–4 seconds. The cylinders are now phased.
3. Shut down the engine, and remove the key from the ignition.
4. Engage the safety props on both lift cylinders as follows:
 - a. Pull lever (A) toward you to release it, then rotate it toward the header to lower the safety prop onto the cylinder.
 - b. Repeat the previous step for the opposite lift cylinder.

IMPORTANT:

Ensure that the safety props engage over the cylinder piston rods. If the safety prop does **NOT** engage properly, raise the header until the safety prop fits over the rod.



Figure 10.14: Ground Speed Lever (GSL)

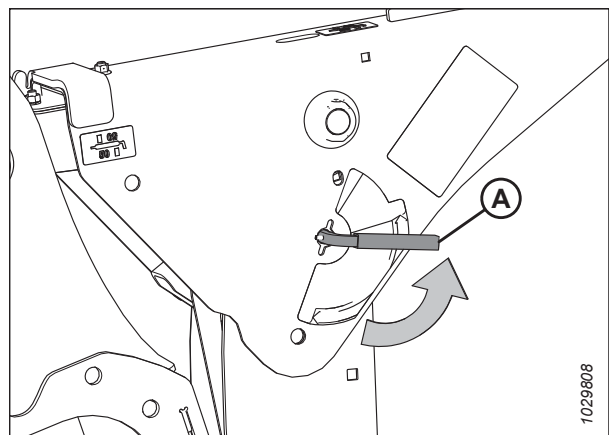

Figure 10.15: Safety Prop Lever

REFERENCE

5. Disengage the safety props on both lift cylinders as follows:
 - a. Turn lever (A) away from the header to raise the safety prop until the lever locks into the vertical position.
 - b. Repeat the previous step for the opposite cylinder.

NOTE:

If the safety prop will **NOT** disengage, raise the header to release the prop.

6. Start the engine.
7. Lower the header fully.
8. Shut down the engine, and remove the key from the ignition.

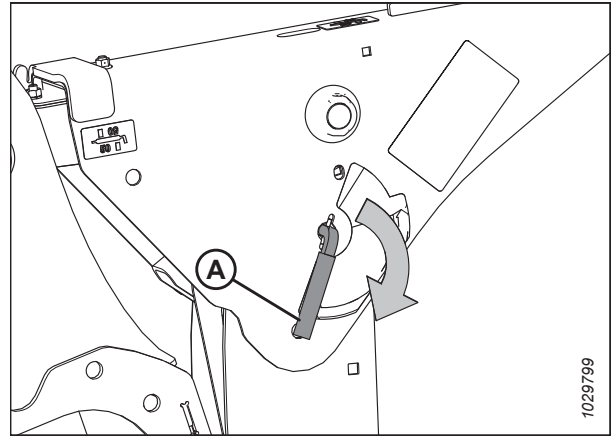

Figure 10.16: Safety Prop Lever

10.4 Engaging and Disengaging Header Safety Props – M Series Self-Propelled Windrower

The safety props are located on both of the header lift cylinders on the windrower. Engage the props anytime you are going to work on or around a raised header. When engaged, the safety props prevent the header from dropping suddenly if the lift system hydraulics lose pressure.

DANGER

To prevent bodily injury from the fall of a raised header, always engage the safety props when working on or around a raised header, and before going under the header for any reason.

DANGER

To avoid bodily injury or death from unexpected startup of the machine, always stop the engine and remove the key from the ignition before leaving the operator's seat for any reason.

DANGER

Ensure that all bystanders have cleared the area.

1. Start the engine.
2. Press HEADER UP switch (A) to raise the header to its maximum height.
3. Rephase the cylinders if one end of the header does not rise fully:
 - a. Press and hold HEADER UP switch (A) until both cylinders stop moving.
 - b. Continue to hold the switch for 3–4 seconds. The cylinders are now phased.



Figure 10.17: Ground Speed Lever (GSL)

REFERENCE

4. To engage the safety prop, pull lever (A) and rotate it toward the header to lower safety prop (B) onto the cylinder. Repeat this step to engage the safety prop on the opposite side of the windrower.

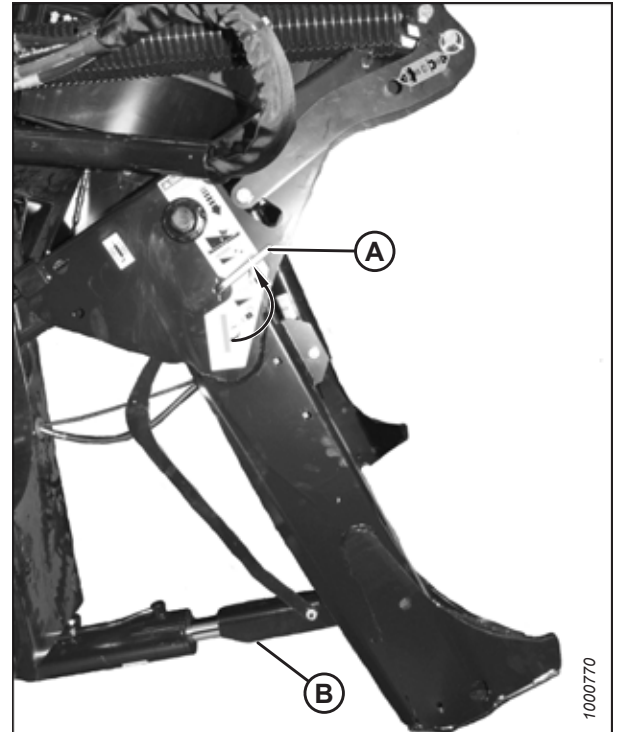

Figure 10.18: Safety Prop

5. To disengage the safety prop, turn lever (A) away from the header to raise the safety prop until the lever locks into the vertical position. Repeat this step to disengage the safety prop on the opposite side of the windrower.
6. Start the engine.
7. Move the windrower to a level area.
8. Lower the header to the ground.
9. Shut down the engine, and remove the key from the ignition.

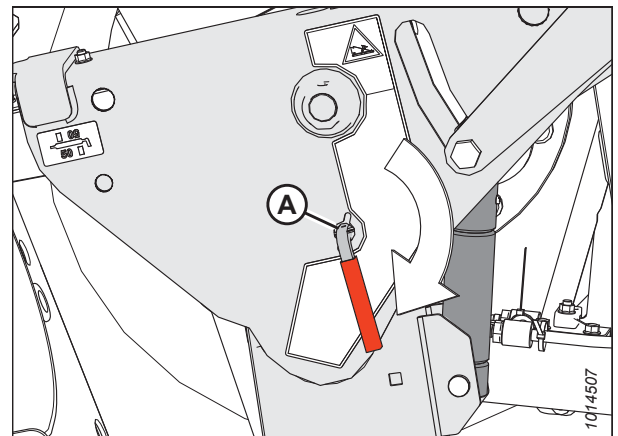

Figure 10.19: Safety Prop

10.5 Leveling Header – M2 Series Windrower

The windrower lift linkages are factory-set to provide the proper header level and should not normally require adjustment.

DANGER

To prevent bodily injury or death from the unexpected startup of the machine, always stop the engine and remove the key from the ignition before leaving the operator's seat for any reason.

If the header level needs to be adjusted, follow these steps:

1. Remove the float spring tension to ensure that the lift windrower linkages are not affected by the float springs. For instructions, refer to [10.8 Removing and Restoring Float for M2 Series Windrowers, page 207](#).

DANGER

Ensure that all bystanders have cleared the area.

2. Start the engine.
3. Park the windrower on level ground.
4. Press header raise button (A) on the ground speed lever (GSL) until the header reaches maximum height. Continue to hold the header raise button for 3–4 seconds to rephase the lift cylinders.



Figure 10.20: Ground Speed Lever (GSL)

5. Lower the header to approximately 150 mm (6 in.) off the ground.
6. Ensure that member (A) is against link (B).
7. Shut down the engine, and remove the key from the ignition.
8. Measure the distance to the ground at both ends of the header to determine if the header is level.

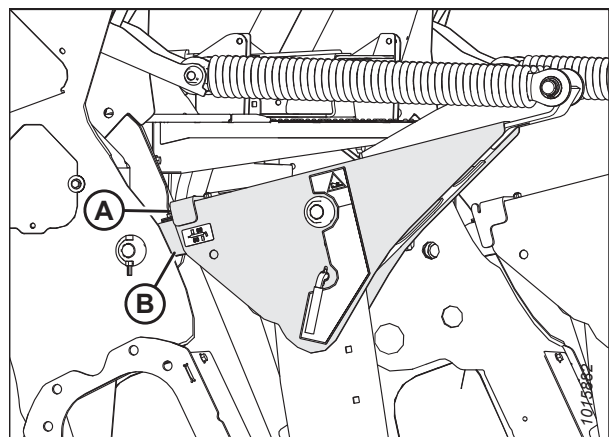

Figure 10.21: Lift Linkage

REFERENCE

9. If adjustment is necessary, start the engine and resume the float. For instructions, refer to [10.8 Removing and Restoring Float for M2 Series Windrowers, page 207](#).
10. Lower the header onto the ground until member (A) lifts away from link (B) on both sides.
11. Shut down the engine, and remove the key from the ignition.

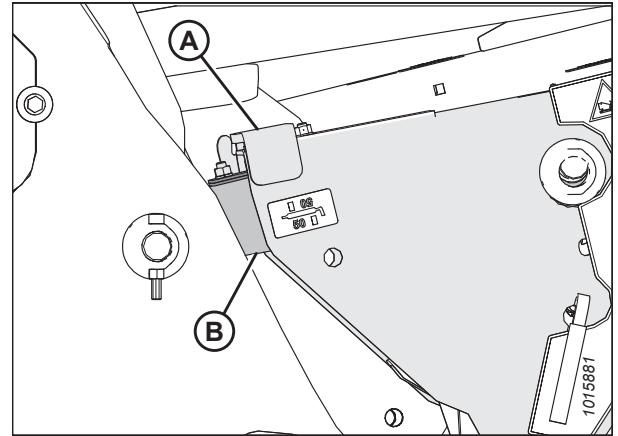

Figure 10.22: Lift Linkage

12. On the side that is higher, remove nut, washer, and bolt (A) that attaches shims (B) to the linkage.
13. Remove one or both of shims (B) and reinstall hardware (A).
14. Repeat Step [4, page 200](#) to Step [8, page 200](#) to rephase the cylinders and check the header level.
15. If additional adjustment is required, repeat Step [9, page 201](#) to Step [12, page 201](#), and install one of the removed shims on the opposite linkage.

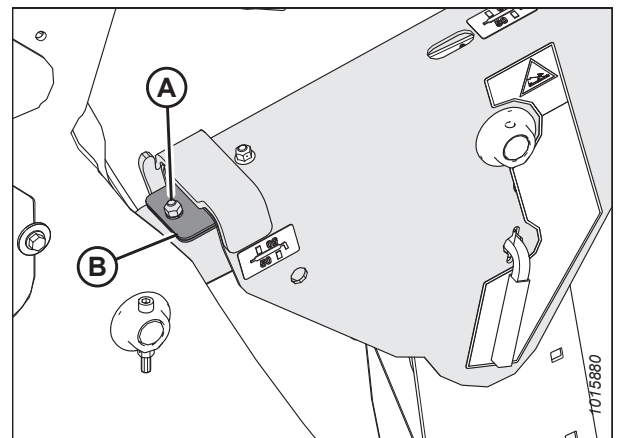

Figure 10.23: Lift Linkage Shims

16. Reset the header float. For instructions, refer to [9.2.2 Setting Float – M2 Series Windrowers, page 164](#).

NOTE:

Additional shims are available from your Dealer.

10.6 Leveling Header – M1 Series Windrower

The windrower lift linkages are factory-set to provide the proper header level, and should not normally require adjustment.

DANGER

To prevent bodily injury or death from the unexpected startup of the machine, always stop the engine and remove the key from the ignition before leaving the operator's seat for any reason.

DANGER

Ensure that all bystanders have cleared the area.

1. Start the engine.
2. Press rotary scroll knob (A) on Harvest Performance Tracker (HPT) to display the QuickMenu page.
3. Rotate scroll knob (A) to highlight HEADER FLOAT symbol (B) and press scroll knob to select. The SET-UP FLOAT page displays.



Figure 10.24: HPT Display

4. Press soft key 3 (A) to remove float.



Figure 10.25: HPT Display

REFERENCE

5. Park the windrower on level ground.
6. Press HEADER RAISE button (A) on the ground speed lever (GSL). When the header reaches its maximum height, continue to hold the header raise button to rephase the lift cylinders.



Figure 10.26: Ground Speed Lever (GSL)

7. Lower the header to approximately 150 mm (6 in.) off the ground.
8. Ensure that channel (A) is against link (B).
9. Shut down the engine, and remove the key from the ignition.
10. Measure the distance to the ground at both ends of the header to determine if the header is level.
11. If adjustment is necessary, start the engine and resume float. Lower the header onto the ground until channel (A) lifts away from the link (B) on both sides.
12. Shut down the engine, and remove the key from the ignition.
13. On the side that is higher, remove hardware (A) attaching shims (B) to the linkage.
14. Remove one or both shims (B) and reinstall hardware (A).
15. Repeat Step 6, page 203 to Step 10, page 203 to rephase the cylinders and check the header level.
16. If additional adjustment is required, repeat Step 11, page 203 to Step 14, page 203, and install one of the removed shims on the opposite linkage.

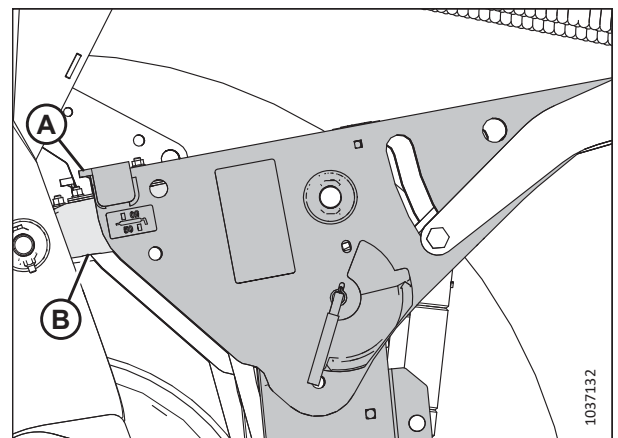

Figure 10.27: Lift Linkage

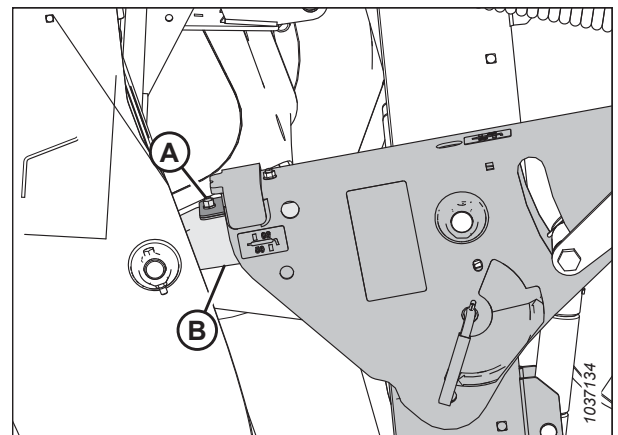

Figure 10.28: Lift Linkage Shims

17. Reset the header float. For instructions, refer to [9.2.3 Setting Float – M1 Series Windrowers, page 166](#).

10.7 Leveling Header – M Series Windrower

The windrower linkages are factory-set to provide the proper header level, and should not normally require adjustment.

DANGER

To prevent bodily injury or death from the unexpected startup of the machine, always stop the engine and remove the key from the ignition before leaving the operator's seat for any reason.

If the header is not level, check the pressure of the windrower's tires before adjusting the leveling linkages.

NOTE:

The float springs are **NOT** used to level the header.

To level the header:

1. Place the float pins in locked-out location (A).

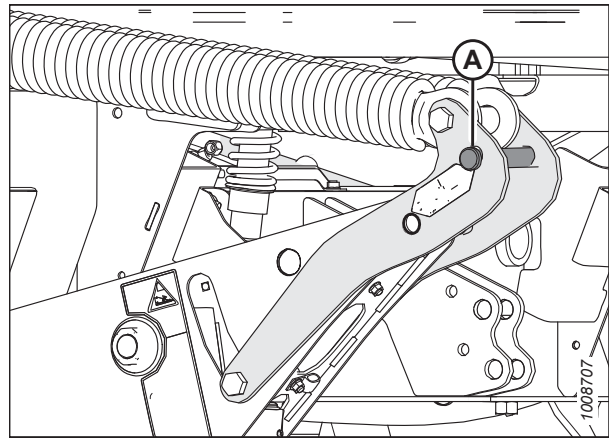

Figure 10.29: Float Pins – Disengaged

DANGER

Ensure that all bystanders have cleared the area.

2. Start the engine.
3. Park the windrower on level ground.
4. Raise the header fully using HEADER UP button (A). Hold the button momentarily to rephase the lift cylinders.



Figure 10.30: Ground Speed Lever (GSL)

REFERENCE

5. Adjust the height of the header until it sits approximately 150 mm (6 in.) off of the ground. Ensure that member (A) rests against link (B).
6. Shut down the engine, and remove the key from the ignition.
7. Measure the distance to the ground from both ends of the header. If the values are the same, then no float adjustment is necessary. If they are different, then the end of the header with the greater distance to the ground will need to be adjusted.
8. If adjustment is necessary, start the engine and raise the header fully.
9. Shut down the engine, and remove the key from the ignition.
10. Move the float pins to engaged position (A).

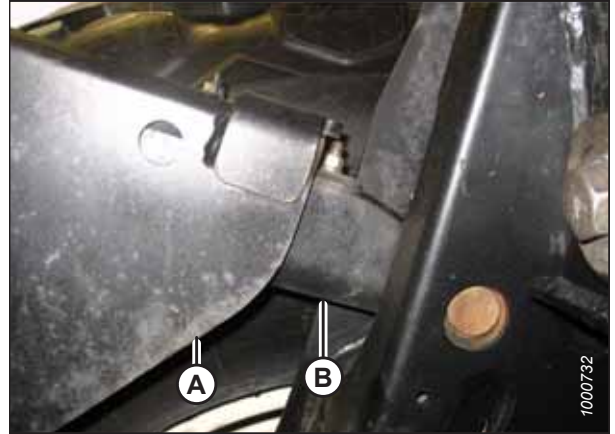

Figure 10.31: Lift Linkage

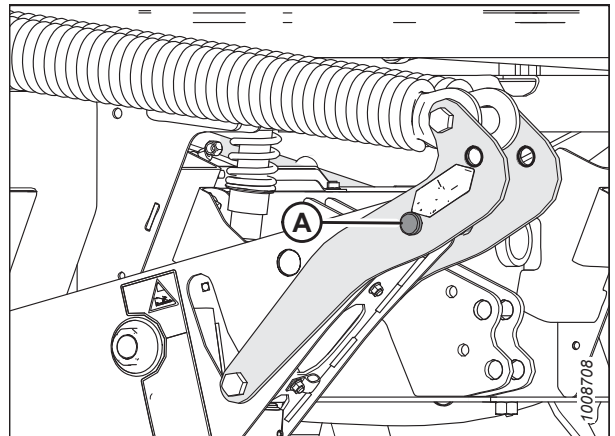

Figure 10.32: Float Pins – Engaged

11. Start the engine.
12. Lower the header onto the ground until member (A) lifts off of link (B) on both sides of the header.
13. Shut down the engine, and remove the key from the ignition.

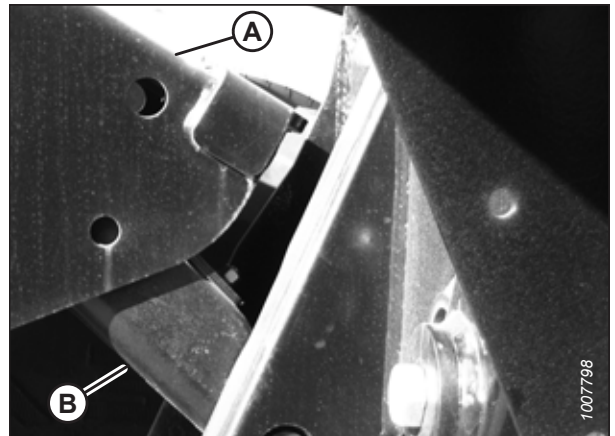

Figure 10.33: Lift Linkage

REFERENCE

14. On the high side of the linkage, remove hardware (A) securing shims (B) to the link.
15. Remove one or both shims (B), and reinstall hardware (A).
16. Start the engine.
17. Raise the header fully.
18. Shut down the engine, and remove the key from the ignition.
19. Move the float pins to the disengaged position.

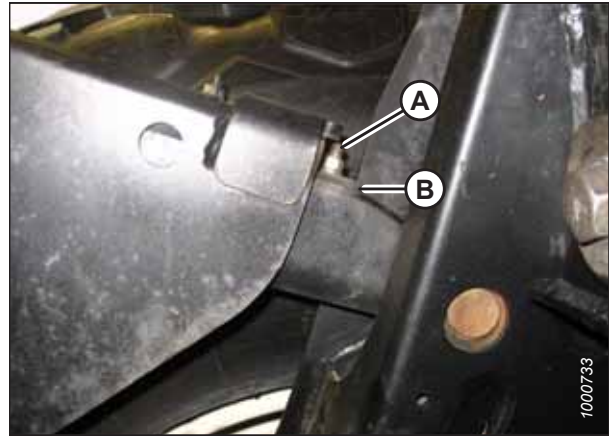

Figure 10.34: Lift Linkage

20. Start the engine.
21. Lower the header so that it sits approximately 150 mm (6 in.) off of the ground.
22. Check that member (A) is resting against link (B).
23. Shut down the engine, and remove the key from the ignition.
24. Measure the distance to the ground from both ends of the header. If the values are the same, then no float adjustment is necessary. If they are different, then the end of the header with the greater distance to the ground will need to be adjusted.
25. If more adjustment is needed, repeat Steps 8, page 205 to 13, page 205 and install the removed shim on the opposite linkage.



Figure 10.35: Lift Linkage

NOTE:

Additional shims are available from your Dealer.

26. Once the header is level, return the float pins to engaged position (A).

NOTE:

The float does **NOT** require adjustment after leveling the header.

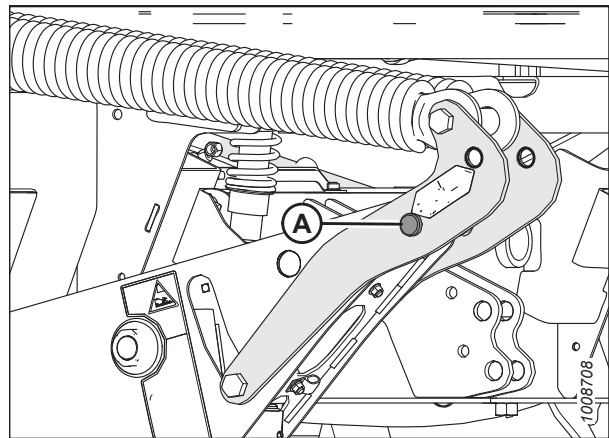

Figure 10.36: Float Pins – Engaged

10.8 Removing and Restoring Float for M2 Series Windrowers

The header float can be removed and restored using the HarvestTouch™ Display.

1. Disengage the safety props on both lift cylinders as follows:
 - a. Turn lever (A) away from the header to raise the safety prop until the lever locks into the vertical position.
 - b. Repeat the previous step for the opposite cylinder.

NOTE:

If the safety prop will **NOT** disengage, raise the header to release the prop.

⚠ DANGER

Ensure that all bystanders have cleared the area.

2. Start the engine.
3. Press HEADER DOWN switch (A) on the ground speed lever (GSL) to fully lower the rotary disc header.

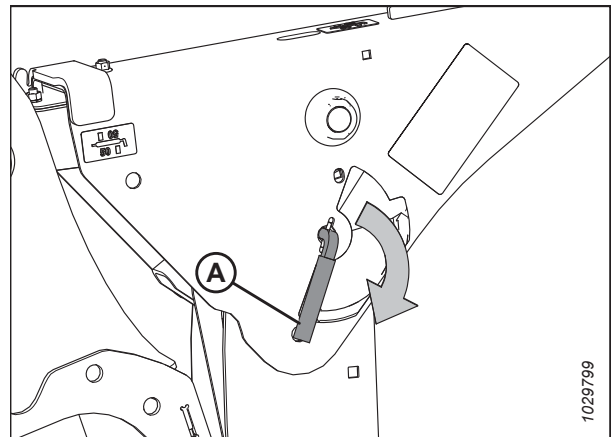

Figure 10.37: Safety Prop Lever

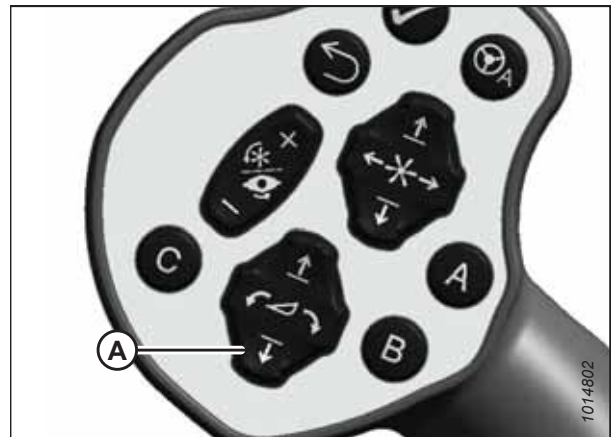

Figure 10.38: Ground Speed Lever (GSL)

4. Press FLOAT SETTINGS icon (A) on the HarvestTouch™ Display to show the float setting page.

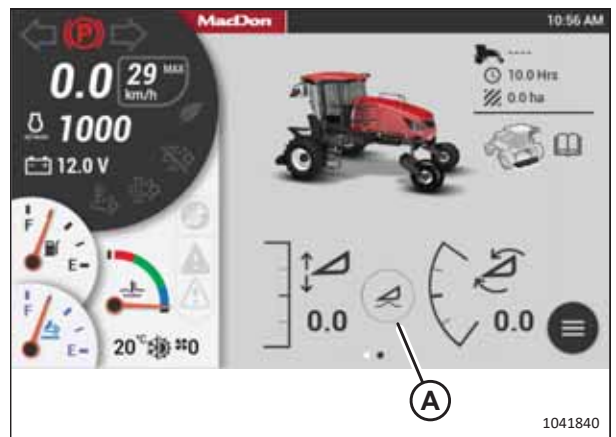

Figure 10.39: HarvestTouch™ Display

REFERENCE

5. Press float switch (A) on the FLOAT ADJUST page to remove or restore the header float.



Figure 10.40: HarvestTouch™ Display

10.9 Removing and Restoring Float for M1 Series Windrowers

The header float can be removed and restored using the Harvest Performance Tracker (HPT) Display.

DANGER

To prevent bodily injury or death from the unexpected startup of the machine, always stop the engine and remove the key from the ignition before leaving the operator's seat for any reason.

1. Disengage the safety props on both lift cylinders as follows:
 - a. Turn lever (A) away from the header to raise the safety prop until the lever locks into the vertical position.
 - b. Repeat the previous step for the opposite cylinder.

NOTE:

If the safety prop will **NOT** disengage, raise the header to release the prop.

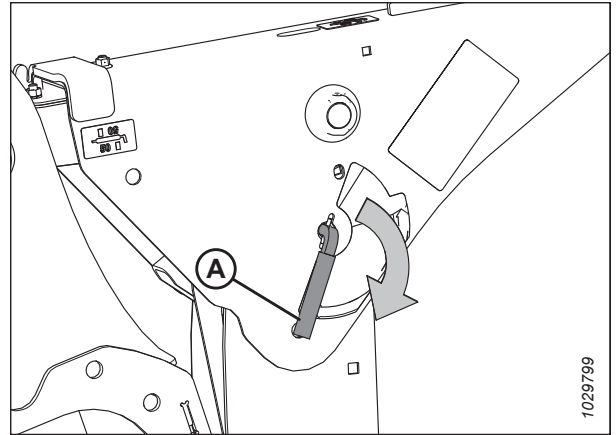

Figure 10.41: Safety Prop Lever

DANGER

Ensure that all bystanders have cleared the area.

2. Start the engine.
3. Press HEADER DOWN switch (A) on the ground speed lever (GSL) to fully lower the rotary disc header.

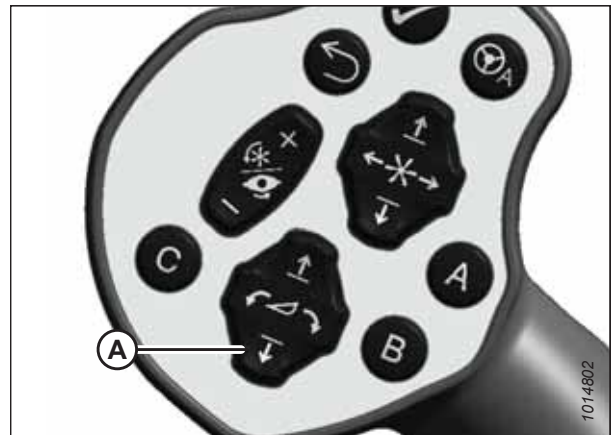

Figure 10.42: Ground Speed Lever (GSL)

REFERENCE

4. If you are not prompted by the Harvest Performance Tracker (HPT) display to restore the header float, restore the header float manually by doing the following:
 - a. Press rotary scroll knob (A) on the HPT to highlight the QuickMenu options.
 - b. Rotate scroll knob (A) to highlight HEADER FLOAT symbol (B), and press the scroll knob to select the symbol. The screen changes.



Figure 10.43: HPT Display

5. Press soft key 3 (A) to restore the header float.

NOTE:

If the header float is active, the icon at soft key 3 will display REMOVE FLOAT; if the header float has been removed, the icon will display RESUME FLOAT.

6. Shut down the engine, and remove the key from the ignition.



Figure 10.44: HPT Display

10.10 Opening Driveshields

Open the driveshields to access the drive components.

DANGER

To prevent injury or death from the unexpected start-up of the machine, always stop the engine and remove the key from the ignition before leaving the operator's seat for any reason.

NOTE:

The illustrations show the left driveshield; the right driveshield is similar.

1. Shut down the engine, and remove the key from the ignition.
2. Push down on release lever (A) to disengage the release latch and pull handle (B).

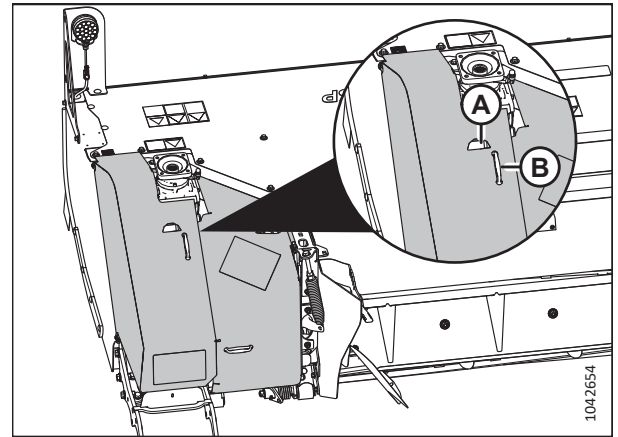

Figure 10.45: Left Driveshield

3. Lift outboard driveshield panel (A) as shown.

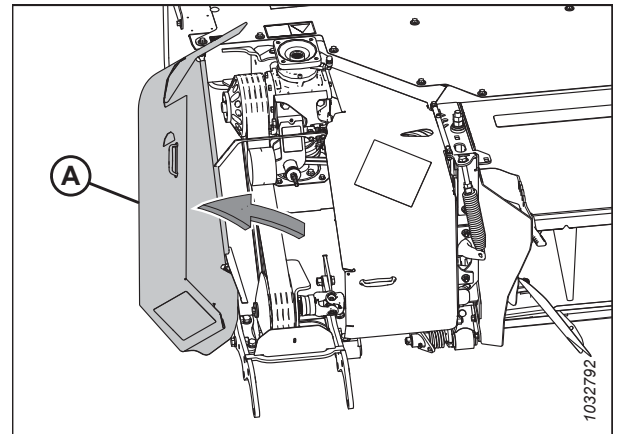

Figure 10.46: Opening Driveshield – Outboard Panel

REFERENCE

4. Pull handle (A) and lift inboard driveshield panel (B) toward the middle of the header.
5. Repeat this procedure to open the right driveshield.

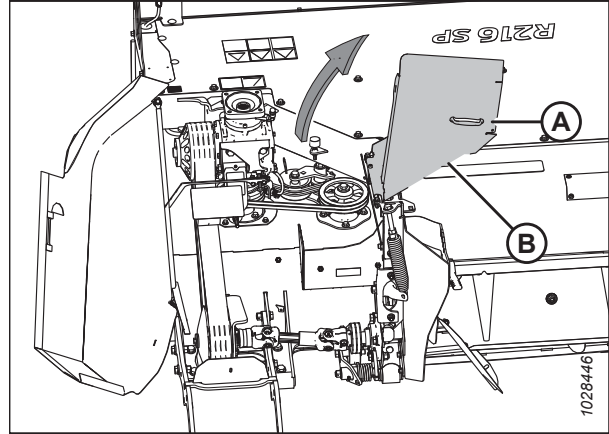

Figure 10.47: Driveshield – Inboard Panel

10.11 Closing Driveshields

Closing the driveshields before operating the machine will protect the drive components from damage.

DANGER

To prevent injury or death from the unexpected start-up of the machine, always stop the engine and remove the key from the ignition before leaving the operator's seat for any reason.

NOTE:

The illustrations show the left driveshield; the right driveshield is similar.

1. Shut down the engine, and remove the key from the ignition.
2. While lifting the driveshield, lift lock latch (A) to disengage the driveshield lock.

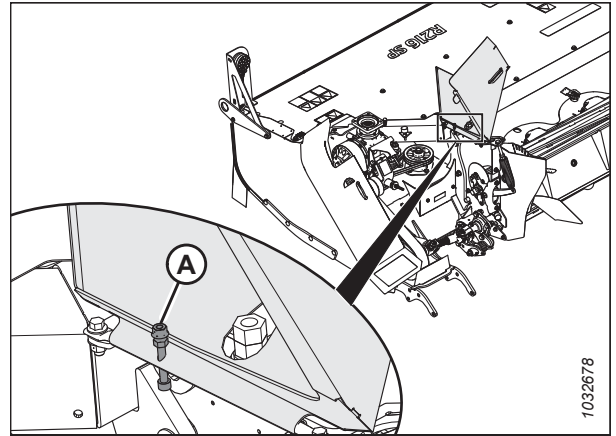

Figure 10.48: Driveshield Lock Latch

3. Move the inboard half of driveshield (A) back to the closed position.

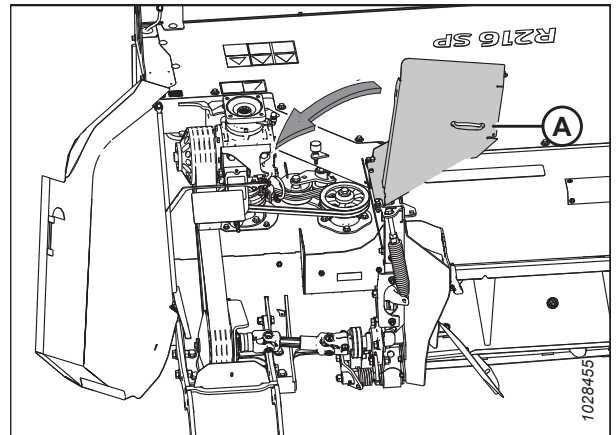

Figure 10.49: Left Driveshield

REFERENCE

4. Move the outboard half of driveshield (A) back to the closed position.
5. Repeat this procedure to close the right driveshield.

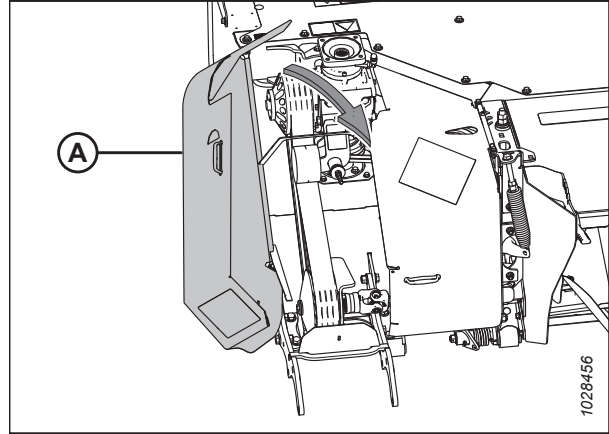

Figure 10.50: Left Driveshield

10.12 Opening Cutterbar Curtain

The cutterbar curtain will need to be opened in order for the cutterbar to be inspected or serviced.

DANGER

To prevent bodily injury or death from the unexpected startup of the machine, always stop the engine and remove the key from the ignition before leaving the operator's seat.

1. Shut down the engine, and remove the key from the ignition.
2. Push curtain (A) inward and up.

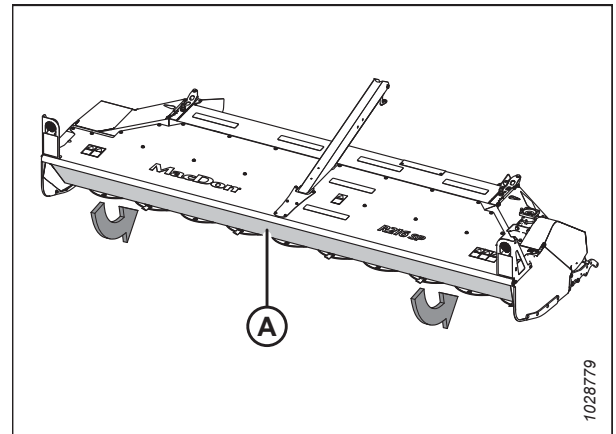

Figure 10.51: Cutterbar Curtain

3. Secure the curtain in place at locations (A) using the three clips provided.

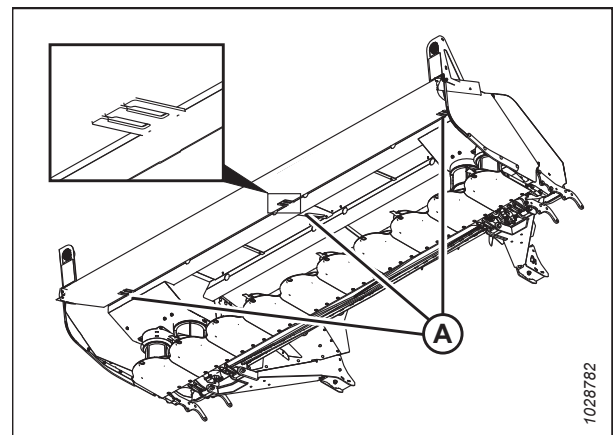

Figure 10.52: Cutterbar Curtain

REFERENCE

NOTE:

Cutterbar curtain (A) is held in place between the tines of retaining clips (B).

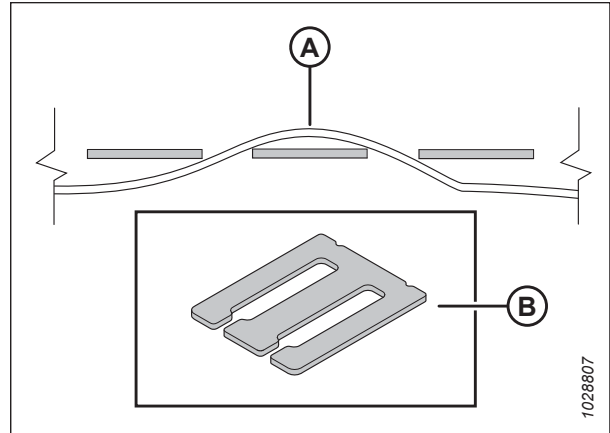

Figure 10.53: Cutterbar Curtain and Retaining Clips

10.13 Closing Cutterbar Curtain

Once your maintenance tasks are complete, the cutterbar curtain must be closed before the header can be operated again.

CAUTION

To avoid injury, keep hands and fingers away from corners of doors when closing.

1. Pull the curtain outward from the retaining clips and lower the curtain.

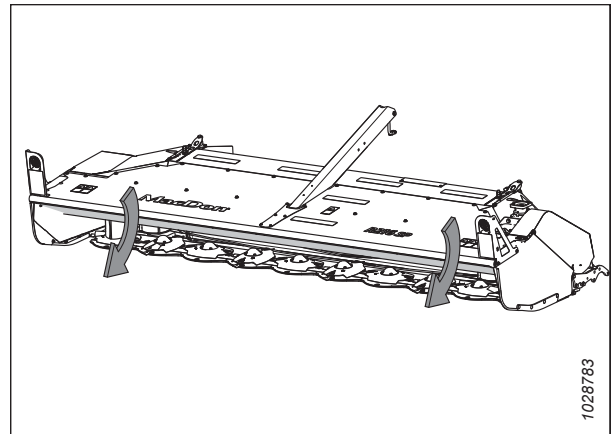

Figure 10.54: Cutterbar Curtain – Standard Header Shown

10.14 Torque Specifications

The following tables provide torque values for various bolts, cap screws, and hydraulic fittings. Refer to these values only when no other torque value has been specified in a given procedure.

- Tighten all bolts to the torque values specified in the charts below, unless you are directed otherwise in this manual.
- Replace removed hardware with hardware of the same strength and grade.
- Refer to the torque value tables as a guide when periodically checking the tightness of bolts.
- Understand the torque categories for bolts and cap screws by reading the markings on their heads.

Jam nuts

Jam nuts require less torque than nuts used for other purposes. When applying torque to finished jam nuts, multiply the torque applied to regular nuts by 0.65 to obtain the modified torque value.

Self-tapping screws

Refer to the standard torque values when installing the self-tapping screws. Do **NOT** install the self-tapping screws on structural or otherwise critical joints.

10.14.1 Metric Bolt Specifications

Specifications are provided for the appropriate final torque values to secure various sizes of metric bolts.

NOTE:

The torque values provided in the following metric bolt torque tables apply to hardware installed dry; that is, hardware with no grease, oil, or threadlocker on the threads or heads. Do **NOT** add grease, oil, or threadlocker to bolts or cap screws unless you are directed to do so in this manual.

Table 10.1 Metric Class 8.8 Bolts and Class 9 Free Spinning Nut

Nominal Size (A)	Torque (Nm)		Torque (lbf-ft) (*lbf-in)	
	Min.	Max.	Min.	Max.
3-0.5	1.4	1.6	*13	*14
3.5-0.6	2.2	2.5	*20	*22
4-0.7	3.3	3.7	*29	*32
5-0.8	6.7	7.4	*59	*66
6-1.0	11.4	12.6	*101	*112
8-1.25	28	30	20	23
10-1.5	55	60	40	45
12-1.75	95	105	70	78
14-2.0	152	168	113	124
16-2.0	236	261	175	193
20-2.5	460	509	341	377
24-3.0	796	879	589	651

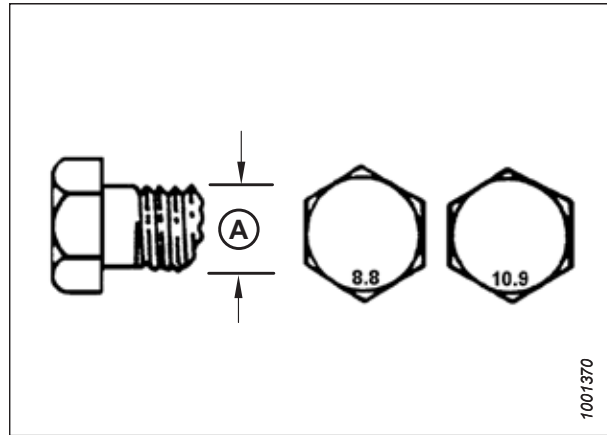

Figure 10.55: Bolt Grades

REFERENCE

Table 10.2 Metric Class 8.8 Bolts and Class 9 Distorted Thread Nut

Nominal Size (A)	Torque (Nm)		Torque (lbf-ft) (*lbf-in)	
	Min.	Max.	Min.	Max.
3-0.5	1	1.1	*9	*10
3.5-0.6	1.5	1.7	*14	*15
4-0.7	2.3	2.5	*20	*22
5-0.8	4.5	5	*40	*45
6-1.0	7.7	8.6	*69	*76
8-1.25	18.8	20.8	*167	*185
10-1.5	37	41	28	30
12-1.75	65	72	48	53
14-2.0	104	115	77	85
16-2.0	161	178	119	132
20-2.5	314	347	233	257
24-3.0	543	600	402	444

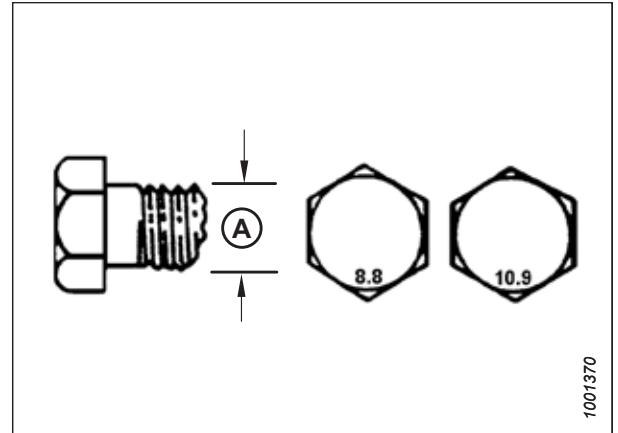

Figure 10.56: Bolt Grades

Table 10.3 Metric Class 10.9 Bolts and Class 10 Free Spinning Nut

Nominal Size (A)	Torque (Nm)		Torque (lbf-ft) (*lbf-in)	
	Min.	Max.	Min.	Max.
3-0.5	1.8	2	*18	*19
3.5-0.6	2.8	3.1	*27	*30
4-0.7	4.2	4.6	*41	*45
5-0.8	8.4	9.3	*82	*91
6-1.0	14.3	15.8	*140	*154
8-1.25	38	42	28	31
10-1.5	75	83	56	62
12-1.75	132	145	97	108
14-2.0	210	232	156	172
16-2.0	326	360	242	267
20-2.5	637	704	472	521
24-3.0	1101	1217	815	901

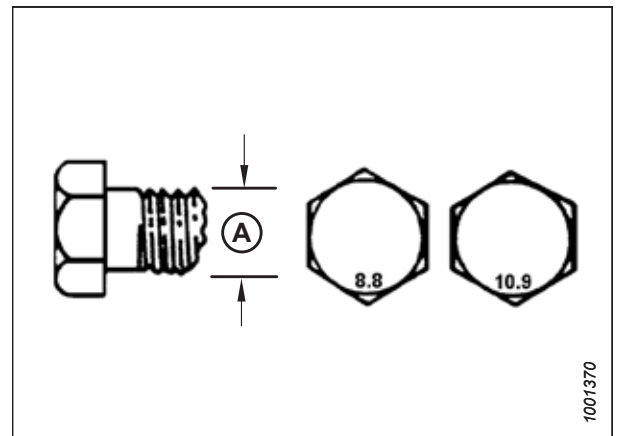

Figure 10.57: Bolt Grades

REFERENCE

Table 10.4 Metric Class 10.9 Bolts and Class 10 Distorted Thread Nut

Nominal Size (A)	Torque (Nm)		Torque (lbf-ft) (*lbf-in)	
	Min.	Max.	Min.	Max.
3-0.5	1.3	1.5	*12	*13
3.5-0.6	2.1	2.3	*19	*21
4-0.7	3.1	3.4	*28	*31
5-0.8	6.3	7	*56	*62
6-1.0	10.7	11.8	*95	*105
8-1.25	26	29	19	21
10-1.5	51	57	38	42
12-1.75	90	99	66	73
14-2.0	143	158	106	117
16-2.0	222	246	165	182
20-2.5	434	480	322	356
24-3.0	750	829	556	614

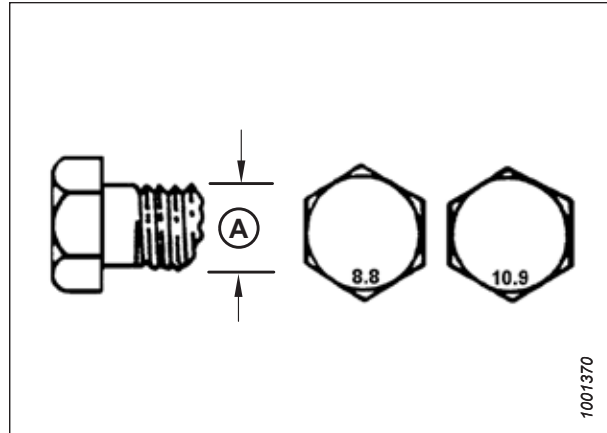

Figure 10.58: Bolt Grades

10.14.2 Metric Bolt Specifications – Cast Aluminum

Specifications are provided for the appropriate final torque values for various sizes of metric bolts in cast aluminum.

NOTE:

The torque values provided in the following metric bolt torque tables apply to hardware installed dry; that is, hardware with no grease, oil, or threadlocker on the threads or heads. Do **NOT** add grease, oil, or threadlocker to bolts or cap screws unless you are directed to do so in this manual.

Table 10.5 Metric Bolt Bolting into Cast Aluminum

Nominal Size (A)	Bolt Torque			
	8.8 (Cast Aluminum)		10.9 (Cast Aluminum)	
	Nm	lbf-ft	Nm	lbf-ft
M3	–	–	–	1
M4	–	–	4	2.6
M5	–	–	8	5.5
M6	9	6	12	9
M8	20	14	28	20
M10	40	28	55	40
M12	70	52	100	73
M14	–	–	–	–
M16	–	–	–	–

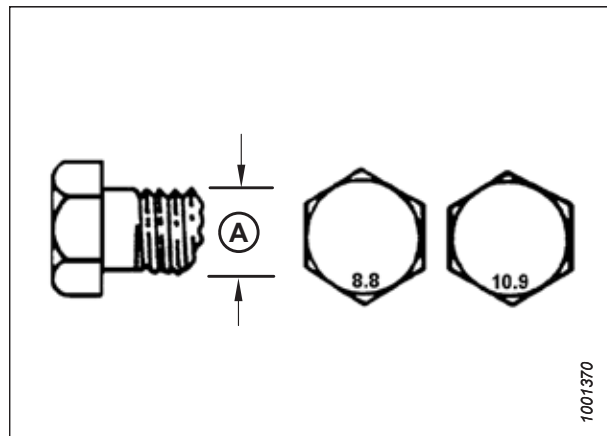

Figure 10.59: Bolt Grades

10.14.3 O-Ring Boss Hydraulic Fittings – Adjustable

The standard torque values are provided for adjustable hydraulic fittings. If a procedure specifies a different torque value for the same type and size of fitting found in this topic, refer to the value specified in the procedure instead.

1. Inspect O-ring (A) and seat (B) for dirt or defects.
2. Back off lock nut (C) as far as possible. Ensure that washer (D) is loose and that it is pushed toward lock nut (C) as far as possible.
3. Ensure that O-ring (A) is **NOT** on the threads. Adjust O-ring (A) if necessary.
4. Apply hydraulic system oil to O-ring (A).

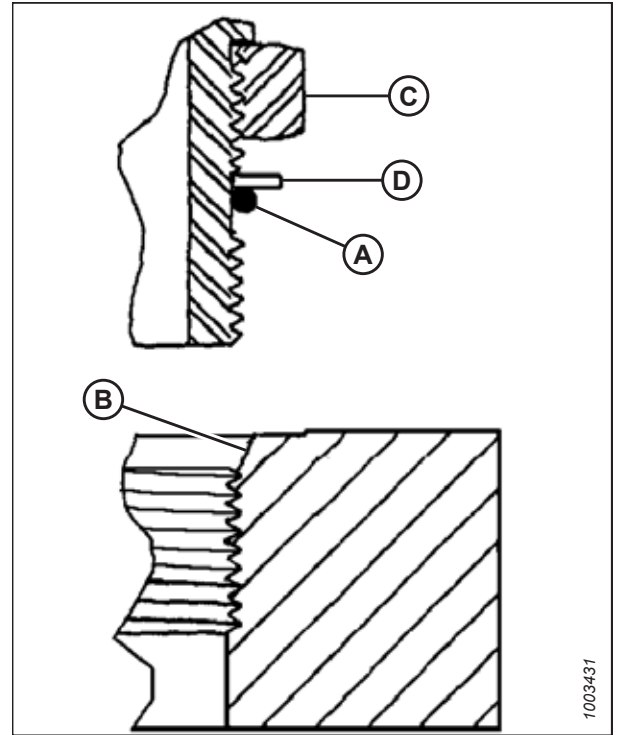

Figure 10.60: Hydraulic Fitting

5. Install fitting (B) into the port until backup washer (D) and O-ring (A) contact part face (E).
6. Position the angle fittings by unscrewing no more than one turn.
7. Turn lock nut (C) down to washer (D) and tighten it to the torque value indicated in the table. Use two wrenches, one on fitting (B) and the other on lock nut (C).
8. Verify the final condition of the fitting.

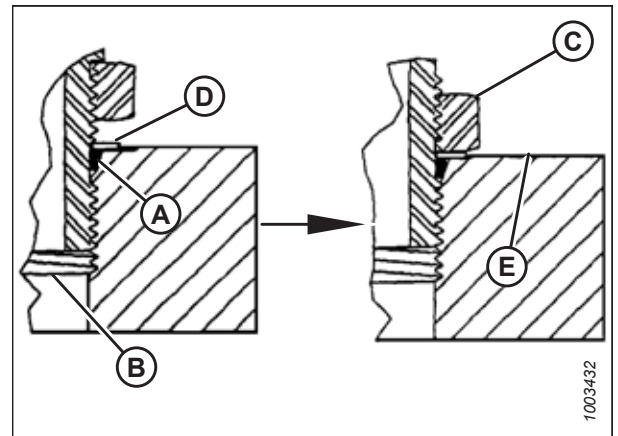

Figure 10.61: Hydraulic Fitting

REFERENCE

Table 10.6 O-Ring Boss (ORB) Hydraulic Fittings – Adjustable and Non-Adjustable

SAE Dash Size	Thread Size (in.)	Torque Value ⁴	
		Nm	lbf·ft (*lbf·in)
-2	5/16–24	10–11	*89–97
-3	3/8–24	18–20	*159–177
-4	7/16–20	29–32	21–24
-5	1/2–20	32–35	24–26
-6	9/16–18	40–44	30–32
-8	3/4–16	70–77	52–57
-10	7/8–14	115–127	85–94
-12	1 1/16–12	183–201	135–148
-14	1 3/16–12	237–261	175–193
-16	1 5/16–12	271–298	200–220
-20	1 5/8–12	339–373	250–275
-24	1 7/8–12	414–455	305–336
-32	2 1/2–12	509–560	375–413

10.14.4 O-Ring Boss Hydraulic Fittings – Non-Adjustable

The standard torque values for non-adjustable hydraulic fittings are provided. If a procedure specifies a different torque value for the same type and size of fitting found in this topic, use the value specified in the procedure instead.

1. Inspect O-ring (A) and seat (B) for dirt or defects.
2. Ensure that O-ring (A) is **NOT** on the threads. Adjust O-ring (A) if necessary.
3. Apply hydraulic system oil to the O-ring.
4. Install fitting (C) into the port until the fitting is hand-tight.
5. Torque fitting (C) according to values in Table 10.7, page 222.
6. Verify the final condition of the fitting.

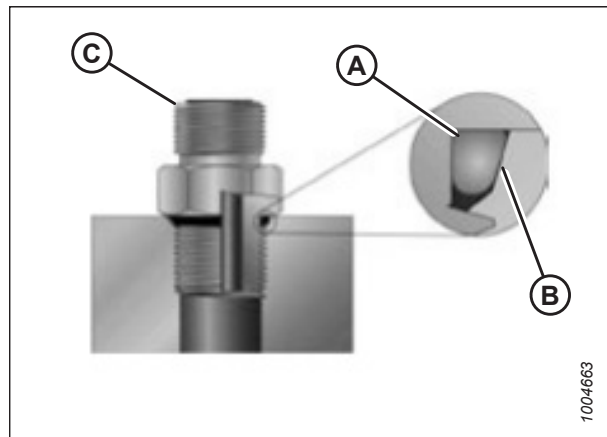

Figure 10.62: Hydraulic Fitting

Table 10.7 O-Ring Boss (ORB) Hydraulic Fittings – Adjustable and Non-Adjustable

SAE Dash Size	Thread Size (in.)	Torque Value ⁴	
		Nm	lbf·ft (*lbf·in)
-2	5/16–24	10–11	*89–97
-3	3/8–24	18–20	*159–177
-4	7/16–20	29–32	21–24
-5	1/2–20	32–35	24–26

4. Torque values shown are based on lubricated connections as in reassembly.

REFERENCE

Table 10.7 O-Ring Boss (ORB) Hydraulic Fittings – Adjustable and Non-Adjustable (continued)

SAE Dash Size	Thread Size (in.)	Torque Value ⁵	
		Nm	lbf·ft (*lbf·in)
-6	9/16-18	40-44	30-32
-8	3/4-16	70-77	52-57
-10	7/8-14	115-127	85-94
-12	1 1/16-12	183-201	135-148
-14	1 3/16-12	237-261	175-193
-16	1 5/16-12	271-298	200-220
-20	1 5/8-12	339-373	250-275
-24	1 7/8-12	414-455	305-336
-32	2 1/2-12	509-560	375-413

10.14.5 O-Ring Face Seal Hydraulic Fittings

The standard torque values are provided for O-ring face seal hydraulic fittings. If a procedure specifies a different torque value for the same type and size of fitting found in this topic, refer to the value specified in the procedure instead.

Torque values are shown in the Table 10.8, page 224.

1. Ensure that the sealing surfaces and the fitting threads are free of burrs, nicks, scratches, and any foreign material.



Figure 10.63: Hydraulic Fitting

5. Torque values shown are based on lubricated connections as in reassembly.

REFERENCE

2. Apply hydraulic system oil to O-ring (B).
3. Align the tube or hose assembly so that the flat face of sleeve (A) or (C) comes into full contact with O-ring (B).
4. Thread tube or hose nut (D) until it is hand-tight. The nut should turn freely until it bottoms out.
5. Torque the fittings according to values in Table 10.8, page 224.

NOTE:

If applicable, hold the hex flange on fitting body (E) to prevent the rotation of the fitting body and the hose when tightening fitting nut (D).

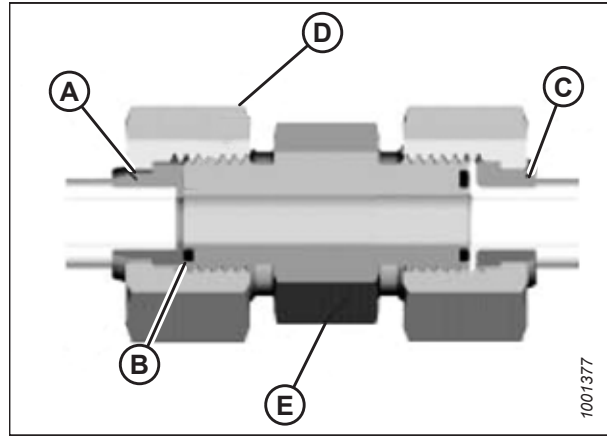

Figure 10.64: Hydraulic Fitting

6. Use three wrenches when assembling unions or joining two hoses together.
7. Verify the final condition of the fitting.

Table 10.8 O-Ring Face Seal (ORFS) Hydraulic Fittings

SAE Dash Size	Thread Size (in.)	Tube O.D. (in.)	Torque Value ⁶	
			Nm	lbf-ft
-3	Note ⁷	3/16	–	–
-4	9/16	1/4	25–28	18–21
-5	Note ⁷	5/16	–	–
-6	11/16	3/8	40–44	30–32
-8	13/16	1/2	55–61	41–45
-10	1	5/8	80–88	59–65
-12	1 3/16	3/4	115–127	85–94
-14	Note ⁷	7/8	–	–
-16	1 7/16	1	150–165	111–122
-20	1 11/16	1 1/4	205–226	151–167
-24	2	1 1/2	315–347	232–256
-32	2 1/2	2	510–561	376–414

10.14.6 Tapered Pipe Thread Fittings

The standard torque values are provided for tapered pipe thread fittings. If a procedure specifies a different torque value for the same type and size of fitting found in this topic, refer to the value specified in the procedure instead.

Assemble pipe fittings as follows:

1. Ensure that the fitting and the port threads are free of burrs, nicks, scratches, and any other form of contamination.
2. Apply paste-type pipe thread sealant to the external pipe threads.
3. Thread the fitting into the port until it is hand-tight.

6. Torque values and angles shown are based on lubricated connection as in reassembly.

7. O-ring face seal type end not defined for this tube size.

REFERENCE

4. Torque the connector to the appropriate torque angle. The turns from finger tight (TFFT) and flats from finger tight (FFFT) values are shown in Table 10.9, page 225. Ensure that the tube end of a shaped connector (typically a 45° or 90° elbow) is aligned to receive the incoming tube or hose assembly. Always finish the alignment of the fitting in the direction of tightening. Never loosen the threaded connectors to achieve alignment.
5. Clean all residue and any excess thread conditioner with an appropriate cleaner.
6. Inspect the final condition of the fitting. Pay special attention to the possibility of cracks in the port opening.
7. Mark the final position of the fitting. If a fitting leaks, disassemble the fitting and check it for damage.

NOTE:

The failure of fittings due to over-torquing may not be evident until the fittings are disassembled and inspected.

Table 10.9 Hydraulic Fitting Pipe Thread

Tapered Pipe Thread Size	Recommended TFFT	Recommended FFFT
1/8-27	2-3	12-18
1/4-18	2-3	12-18
3/8-18	2-3	12-18
1/2-14	2-3	12-18
3/4-14	1.5-2.5	12-18
1-11 1/2	1.5-2.5	9-15
1 1/4-11 1/2	1.5-2.5	9-15
1 1/2-11 1/2	1.5-2.5	9-15
2-11 1/2	1.5-2.5	9-15

REFERENCE

10.15 Conversion Chart

This manual uses both SI units (including metric) and US customary units (sometimes referred to as standard units) of measurement. A list of those units along with their abbreviations and conversion factors is provided here for your reference.

Table 10.10 Conversion Chart

Quantity	SI Units (Metric)		Factor	US Customary Units (Standard)	
	Unit Name	Abbreviation		Unit Name	Abbreviation
Area	hectare	ha	x 2.4710 =	acre	acres
Flow	liters per minute	L/min	x 0.2642 =	US gallons per minute	gpm
Force	Newton	N	x 0.2248 =	pound force	lbf
Length	millimeter	mm	x 0.0394 =	inch	in.
Length	meter	m	x 3.2808 =	foot	ft.
Power	kilowatt	kW	x 1.341 =	horsepower	hp
Pressure	kilopascal	kPa	x 0.145 =	pounds per square inch	psi
Pressure	megapascal	MPa	x 145.038 =	pounds per square inch	psi
Pressure	bar (Non-SI)	bar	x 14.5038 =	pounds per square inch	psi
Torque	Newton meter	Nm	x 0.7376 =	pound feet or foot pounds	lbf-ft
Torque	Newton meter	Nm	x 8.8507 =	pound inches or inch pounds	lbf-in
Temperature	degrees Celsius	°C	(°C x 1.8) + 32 =	degrees Fahrenheit	°F
Velocity	meters per minute	m/min	x 3.2808 =	feet per minute	ft/min
Velocity	meters per second	m/s	x 3.2808 =	feet per second	ft/s
Velocity	kilometers per hour	km/h	x 0.6214 =	miles per hour	mph
Volume	liter	L	x 0.2642 =	US gallon	US gal
Volume	milliliter	mL	x 0.0338 =	ounce	oz.
Volume	cubic centimeter	cm ³ or cc	x 0.061 =	cubic inch	in. ³
Weight	kilogram	kg	x 2.2046 =	pound	lb.

REFERENCE

10.16 Definitions

The following terms, abbreviations, and acronyms are used in this instruction.

Table 10.11 Definitions

Term	Definition
API	American Petroleum Institute
ASTM	American Society of Testing and Materials
Bolt	A headed and externally threaded fastener designed to be paired with a nut
Cab-forward	Windrower operation mode in which the Operator's seat faces the header
CDM	Cab display module on an M Series Windrower
Center-link	A hydraulic cylinder or manually adjustable turnbuckle type connection between the header and the vehicle, which is used to change the angle of the header relative to the vehicle
CGVW	Combined gross vehicle weight
DWA	Double Windrow Attachment
Export header	The header configuration typical outside North America
FFFT	Flats from finger tight
Finger tight	Is a reference position in which the given sealing surfaces or components are making contact with each other. The fitting has been tightened by hand to a point where the fitting is no longer loose and cannot be tightened further by hand
GSS	Grass Seed
GVW	Gross vehicle weight
Hard joint	A joint made with use of a fastener where joining materials are highly incompressible
HarvestTouch™ Display	Display / touch screen controller on an M2 Series Windrower
Header	A machine that cuts and lays crop into a windrow when attached to a windrower
Hex key	A tool of hexagonal cross-section used to drive bolts and screws that have a hexagonal socket in the head (internal-wrenching hexagon drive); also known as an Allen key
HPT display	Harvest Performance Tracker display module on an M1 Series Windrower
JIC	Joint Industrial Council: A standards body that developed standard sizing and shape for the original 37° flared fitting
M Series Windrowers	MacDon M100, M105, M150, M155, M155E4, M200, and M205 Windrowers
M1 Series Windrowers	MacDon M1170, M1170NT, M1170NT5, and M1240 Windrowers
M2 Series Windrowers	MacDon M2170 and M2260 Windrowers
n/a	Not applicable
North American header	The header configuration typical in North America
NPT	National Pipe Thread: A style of fitting used for low-pressure port openings. Threads on NPT fittings are uniquely tapered for an interference fit
Nut	An internally threaded fastener designed to be paired with a bolt
ORB	O-ring boss: A style of fitting commonly used in port openings on manifolds, pumps, and motors
ORFS	O-ring face seal: A style of fitting commonly used for connecting hoses and tubes. This style of fitting is also commonly called ORS, which stands for O-Ring Seal
PARK	The slot opposite the NEUTRAL position on operator's console of M1 and M2 Series Windrowers
R2 SP Series Header	MacDon R216 Rotary Disc Headers for windrowers
rpm	Revolutions per minute

REFERENCE

Table 10.11 Definitions (continued)

Term	Definition
SAE	Society of Automotive Engineers
Screw	A headed and externally threaded fastener that threads into preformed threads or forms its own thread when it is inserted into a mating part.
Soft joint	A flexible joint made by use of a fastener in which the joining materials compress or relax over a period of time
Tension	An axial load placed on a bolt or screw, usually measured in Newtons (N) or pounds (lb.). This term can also be used to describe the force a belt exerts on a pulley or sprocket
TFFT	Turns from finger tight
Torque	The product of a force * the length of a lever arm, usually measured in Newton-meters (Nm) or foot-pounds (lbf·ft)
Torque angle	A tightening procedure in which a fitting is assembled to a specified tightness (usually finger tight) and then the nut is turned farther by a specified number of degrees until it achieves its final position
Torque-tension	The relationship between the assembly torque applied to a piece of hardware and the axial load it induces in a bolt or screw
Washer	A thin cylinder with a hole or a slot located in the center, used as a spacer, a load distribution element, or a locking mechanism
Windrower	The power unit for a header

Predelivery Checklist

Perform these checks and adjustments before delivering the machine to the Customer. If adjustments are required, refer to the appropriate page number in this manual. The completed Checklist should be retained by either the Operator or the Dealer.

WARNING

Do NOT operate the machine with the driveshields open. High speed rotating components may throw debris and could result in death or serious injury.

CAUTION

Carefully follow the instructions given. Be alert for safety-related messages that bring your attention to hazards and unsafe practices.

Header Serial Number:

✓	Item	Reference
	Ensure that the header is level.	<p>For M2 Series Windrowers – 10.5 Leveling Header – M2 Series Windrower, page 200</p> <p>For M1 Series Windrowers – 10.6 Leveling Header – M1 Series Windrower, page 202</p> <p>For M Series Windrowers – 10.7 Leveling Header – M Series Windrower, page 204</p>
	If skid shoes or gauge rollers have been installed, ensure that they are evenly set on both sides of the header.	—
	Standard header – Ensure that all shipping accessories, supports, and stands have been removed from the header.	<ul style="list-style-type: none"> • 4.1.1 Removing Shipping Wire from Bottom of Header – Standard Headers Only, page 15 • 4.1.3 Removing Forming Shield Crate – Standard Headers Only, page 18 • 4.1.5 Removing Shipping Stand, page 21 • 4.1.4 Unpacking Hydraulic Hoses and Electrical Harness, page 19
	Header with grass seed (GSS) option – Ensure that all shipping accessories, supports, and stands have been removed from the header.	<ul style="list-style-type: none"> • 4.1.5 Removing Shipping Stand, page 21 • 4.1.4 Unpacking Hydraulic Hoses and Electrical Harness, page 19
	Ensure that the cable ties have been removed from the cutterbar curtain, and that the cutterbar curtain hangs properly.	6 Unpacking the Curtain, page 151
	Ensure that the side forming shields are evenly set.	4.4 Assembling and Installing Forming Shield, page 30
	Ensure that the baffle deflectors are set in field position and that the rear baffle is fully up for headers with the Double Windrow Attachment (DWA) option, or fully down for headers without the DWA option.	4.3 Installing Manual Rear Deflectors – Standard Headers Only, page 28
	Standard header – Grease all bearings and drivelines.	8.1 Lubrication Locations – Standard Headers, page 158
	Header with grass seed (GSS) option – Grease all bearings and drivelines.	8.2 Lubrication Locations – Grass Seed Headers, page 160

REFERENCE

✓	Item	Reference
	Standard header – Check the main drive belt tension.	<i>9.1.1 Inspecting Conditioner Drive Belt, page 161</i>
	Ensure that the suspended drum drive belts are tensioned.	<i>9.5.1 Checking Suspended Drum Drive, page 177</i>
	Standard header – Check the lubricant in the conditioner roll timing gearbox.	<i>9.6 Checking and Adding Oil in Conditioner Timing Gearbox – Standard Header, page 178</i>
	Check the lubricant in the drive gearbox.	<i>9.7 Checking and Adding Oil in Header Drive Gearbox, page 179</i>
	Check the header for shipping damage or missing parts. Remove all shipping dunnage.	—
	Check the lubricant in the cutterbar.	<i>9.8 Checking and Adding Lubricant in Cutterbar, page 180</i>
	Check the header for loose hardware. Tighten any loose hardware to the required torque specifications.	<i>10.14 Torque Specifications, page 218</i>
	Header with grass seed (GSS) option – Ensure that the drums move properly with no binding.	—
	Check the cutterbar area for any loose parts and hardware.	—
Run-Up Procedure		<i>9.12 Running up Header, page 186</i>
	Check the hydraulic hose and wiring harness routing to ensure that there is an adequate clearance when the header is raised or lowered.	—
	Check the hazard lights.	<i>9.9 Checking Lights, page 183</i>
	Header with grass seed (GSS) option – Confirm that the grass seed option is operational.	For M2 Series Windrowers – <i>9.3 Activating Grass Seed Option – M2 Series Windrowers, page 171</i> For M1 Series Windrowers – <i>9.4 Activating Grass Seed Option – M1 Series Windrowers, page 173</i>
	Header with grass seed (GSS) option – Confirm the left drums turn toward the right of the header. Confirm the right drums turn toward the left of the header.	For M2 Series Windrowers – <i>9.3 Activating Grass Seed Option – M2 Series Windrowers, page 171</i> For M1 Series Windrowers – <i>9.4 Activating Grass Seed Option – M1 Series Windrowers, page 173</i>
	Header with grass seed (GSS) option – Test drum movement (adjust the width of the windrow). Ensure that the drums do NOT contact the cutterbar.	For M2 Series Windrowers – <i>9.3 Activating Grass Seed Option – M2 Series Windrowers, page 171</i> For M1 Series Windrowers – <i>9.4 Activating Grass Seed Option – M1 Series Windrowers, page 173</i>
Post Run-Up Check – Stop Engine		
	Check the header for hydraulic leaks.	—
	Standard header – Check the belt drive for proper idler alignment and any overheated bearings.	<i>9.1 Conditioner Drive Belt – Standard Header, page 161</i>
	Ensure that the header manuals are in the storage compartment.	<i>9.10 Checking Manual Storage Case, page 184</i>
	Ensure the timing tool and the spindle nut wrench are stored on the panel at the right end of the header.	<i>9.11 Checking Parts in Storage Location, page 185</i>
	Header with grass seed (GSS) option – Ensure that two feed plates and four support angles are stored on the panel at the right end of the header.	<i>9.11 Checking Parts in Storage Location, page 185</i>

Date Checked:

Checked by:

Recommended Lubricants

Keep your machine operating at top efficiency by using only clean lubricants and by ensuring the following:

- Use clean containers to handle all lubricants.
- Store lubricants in an area protected from dust, moisture, and other contaminants.

IMPORTANT:

Do **NOT** overfill the cutterbar when adding lubricant. Overfilling the cutterbar with lubricant can result in overheating and failure of cutterbar components.

Specification	Description	Use	Capacities
Lubricant: Grease			
SAE Multipurpose	High-temperature extreme-pressure (EP) performance with 1% max. molybdenum disulphide (NLGI Grade 2) lithium base	As required unless otherwise specified	—
SAE Multipurpose	High-temperature extreme-pressure (EP) performance with 10% max. molybdenum disulphide (NLGI Grade 2) lithium base	Driveline slip-joints	—
Lubricant: Gear Lubricant			
SAE 80W-90	High thermal and oxidation stability API service class GL-5	4.9 m (16 ft.) cutterbar	10 liters (10.5 qts [US])
SAE 80W-140	Gear lubricant API service class GL-5	Conditioner roll timing gearbox	0.7 liters (0.75 qts [US])
SAE 80W-140	Fully Synthetic Oil API GL-5 Minimum, SAE J2360 Preferred	Header drive 90 degree gearbox	1.8 liters (1.9 qts [US])

MacDon®

CUSTOMERS
MacDon.com

DEALERS
Portal.MacDon.com

Trademarks of products are the marks of their
respective manufacturers and/or distributors.

Printed in Canada