

## Adjusting the Windrow

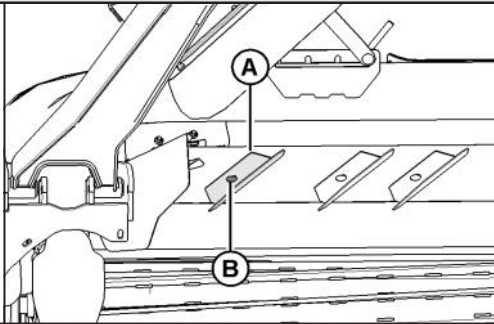

**Adjusting Rear Baffle Deflector Fins**

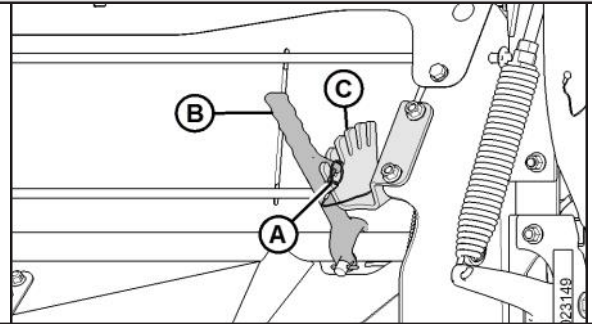

**Adjusting Rear Baffle Plate — Roll Conditioner**

**Control material distribution across windrow. Narrower windrow.**

1. Remove fins from storage position (on top of baffle).
2. Position deflector fin (A) under baffle.
3. Secure with existing bolt and nut (B) (bolt head facing down).
4. Adjust to approximately 60° angle (as shown).
5. Torque nut to 69 Nm (51 lbf-ft). Repeat on other side.
6. Repeat for remaining fins.

**Controls windrow height/width. Directs crop flow that affects width.**

1. Remove lynch pin (A).
2. Pull lever (B) inboard to disengage bracket (C):
  - Move lever forward (raise baffle) for narrow swath.
  - Move lever backward (lower baffle) for wide swath.
3. Release lever so tab engages the notch in bracket (C).
4. Secure lever with lynch pin (A).

## Adjusting Forming Shield Side Deflectors — Roll Conditioner

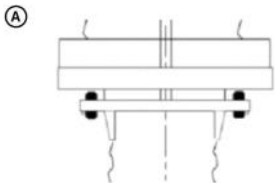

Deflectors are angled outward for wide swaths (A).

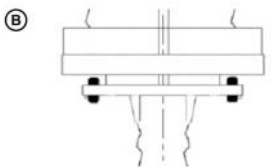

Deflectors are angled inward for narrow swaths (B).

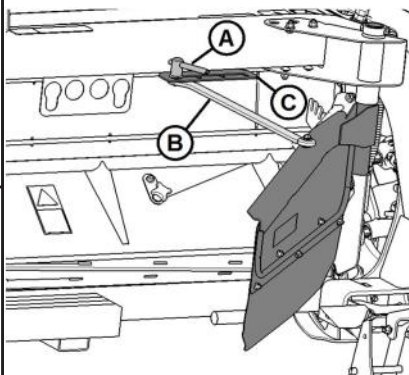

**Controls windrow width and placement.**

1. Loosen locking handle (A).
2. Slide adjuster bar (B) along adjuster plate (C) to the desired position.
3. Engage bar (B) into a notch in the adjuster plate.
4. Tighten locking handle (A).
5. Adjust the other side to the same position.
6. Adjust the rear baffle as required.

## Ground Speed Chart

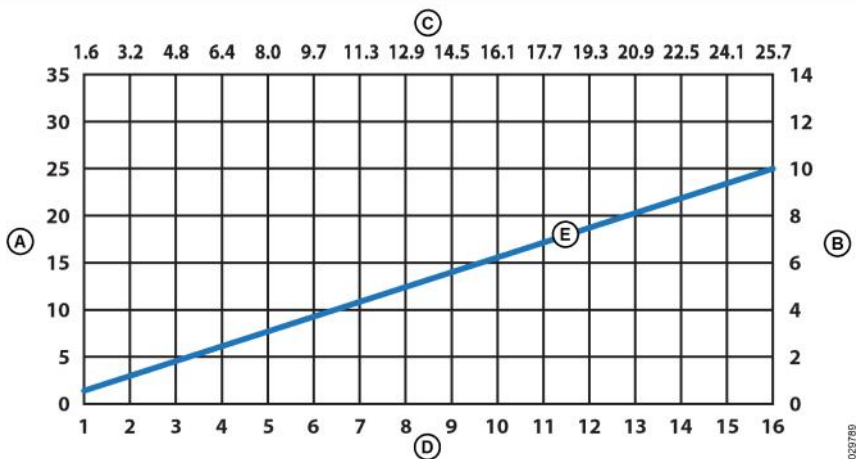

A - acres/hour      B - hectares/hour      C - km/hour      D - mph      E - R113 SP

For firm and level ground, increase the ground speed to 16 km/h (10 mph) and higher, or until the quality of cutting and conditioning are compromised.

For uneven and loose ground, slow the ground speed to minimize bouncing and prevent cutterbar damage and uneven stubble.

## Disc Speed

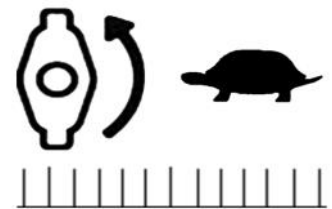

Light/Thin Crop



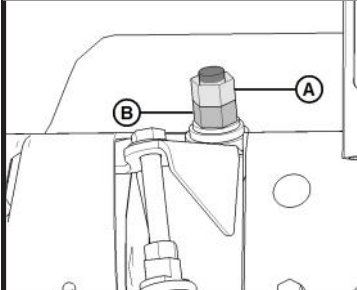
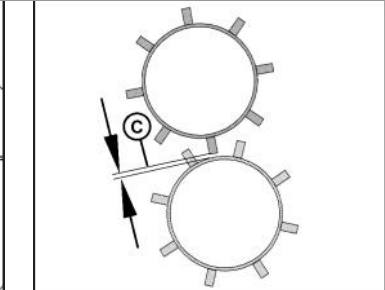
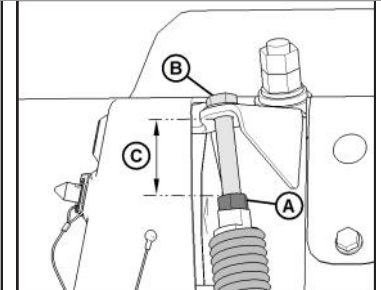
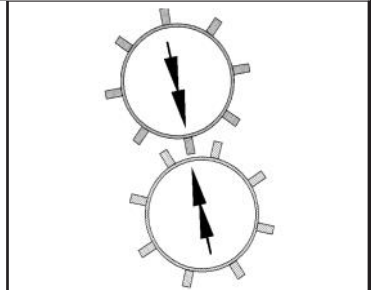

Heavy/Tough Crop

## Adjusting the Conditioner Rolls

			
<h3>Adjusting Roll Gap</h3>		<h3>Adjusting Roll Tension</h3>	
<p><b>Increase conditioning:</b></p> <ol style="list-style-type: none"> <li>Loosen jam nut (A) on both sides of the conditioner.</li> <li>Turn lower nut (B) counterclockwise to decrease roll gap (C).</li> <li>Tighten jam nut (A) on both sides of the conditioner.</li> </ol> <p><b>Decrease conditioning:</b></p> <ol style="list-style-type: none"> <li>Loosen jam nut (A) on both sides of the conditioner.</li> <li>Turn lower nut (B) clockwise to increase roll gap (C).</li> <li>Tighten jam nut (A) on both sides of the conditioner.</li> </ol>		<p><b>Decrease tension (light crops):</b></p> <ol style="list-style-type: none"> <li>Loosen jam nut (A) on both sides of the conditioner.</li> <li>On both sides of the conditioner, turn bolt (B) counterclockwise to increase exposed thread (C) an equal amount.</li> <li>Tighten jam nut (A) on both sides of the conditioner.</li> </ol> <p><b>Increase tension (heavy or tough crops):</b></p> <ol style="list-style-type: none"> <li>Loosen jam nut (A) on both sides of the conditioner.</li> <li>Turn bolt (B) clockwise to decrease exposed thread (C) an equal amount on both sides of the conditioner.</li> <li>Tighten jam nut (A) on both sides of the conditioner.</li> </ol>	

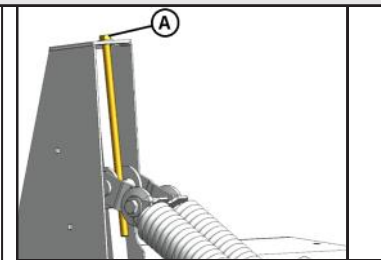
## Setting Float

		
<h3>M1170/M1240 Windrower</h3>	<h3>M155/M155E4 SP Windrower</h3>	
<ol style="list-style-type: none"> <li>Turn scroll knob (A) to highlight left float (B) or right float (C).</li> <li>Press knob (A) to activate the selection.</li> <li>Rotate the scroll knob to adjust the float setting.</li> <li>Press the scroll knob when finished making setting adjustments.</li> </ol> <p><b>NOTE:</b> Adjust the float in small increments.</p>	<ol style="list-style-type: none"> <li>Coarse adjust float with drawbolts (A) on both sides of windrower: <ul style="list-style-type: none"> <li>Turn clockwise to <b>increase</b> float (makes header lighter).</li> <li>Turn counterclockwise to <b>decrease</b> float (makes header heavier).</li> </ul> </li> <li>Fine adjust left float with switch (B) or right float with switch (C): <ul style="list-style-type: none"> <li>Setting displays at location (D).</li> <li>Press + to increase or - to decrease float.</li> </ul> </li> </ol>	

## Adjusting Cutting Height

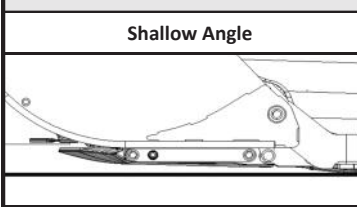
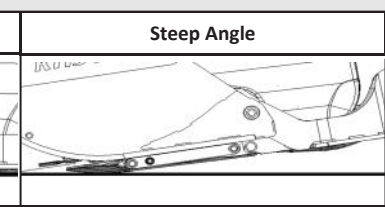
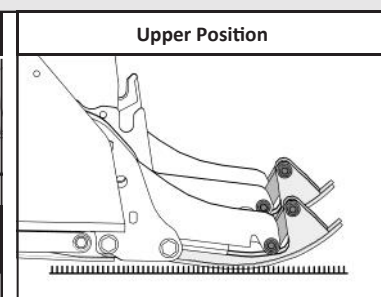
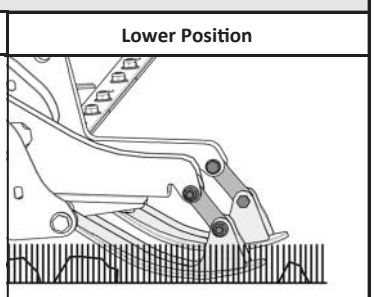
<h3>Shallow Angle</h3> 	<h3>Steep Angle</h3> 	<h3>Upper Position</h3> 	<h3>Lower Position</h3> 
<h3>Header Angle</h3> <p>Use a shallow angle when the ground is loose or uneven.</p> <p>Use a steep angle when the ground is firm, level, or smooth.</p>		<h3>Skid Shoes</h3>	
<p><b>NOTE:</b> Check the float after significantly changing the header angle.</p>		<p>Use the upper position when the ground is smooth, or to produce a short stubble.</p>	<p>Use the lower position when the ground is uneven, or to produce a high stubble.</p>

Subject to change without notice