

Conditioning

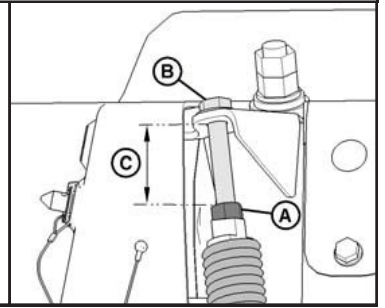
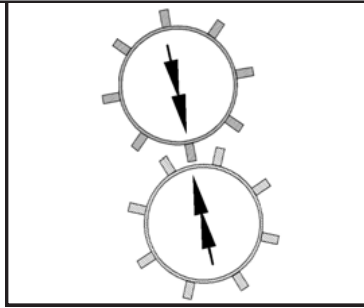
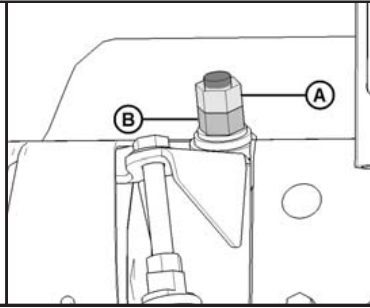
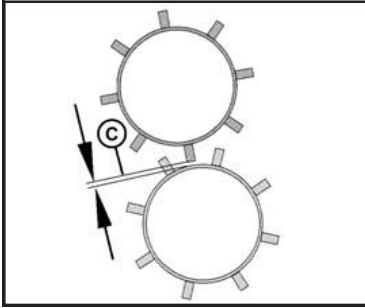

Roll Gap

Decrease conditioning:

1. Loosen jam nut (A).
2. Turn lower nut (B) clockwise to increase roll gap (C).
3. Tighten jam nut (A).

Increase conditioning:

1. Loosen jam nut (A).
2. Turn lower nut (B) counterclockwise to decrease roll gap (C).
3. Tighten jam nut (A).

Roll Tension

Light crops – less tension:

1. Loosen jam nut (A).
2. Turn bolt (B) counterclockwise to increase exposed thread (C).
3. Tighten jam nut (A).

Heavy/tough crops – more tension:

1. Loosen jam nut (A).
2. Turn bolt (B) clockwise to decrease exposed thread (C).
3. Tighten jam nut (A).

Header Auxiliary Lift System

Relay Switch (A) Positions

Automatic (right): select when operating in normal conditions. The auxiliary lift cylinders will extend or retract according to feedback from the position sensors. **NOTE:** the tractor's front hydraulics must be ON and the flow rate adjusted to 15–20 %.

Off (center): select to turn the lift assist system off when servicing, storing, or transporting.

Manual (left): select to use the tractor's front hydraulic circuit controls to manually extend or retract the auxiliary lift cylinders.

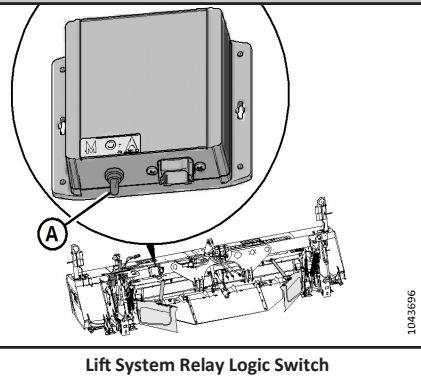

Lift System Relay Logic Switch

1043696

Operating: remove auxiliary lift lock straight pins (A) from holes in lift linkage on both sides of the header and store at location (B) on the left side of the carrier frame.

Before disconnecting from a tractor: install auxiliary lift lock straight pins (A) into holes in lift linkage on both sides of the header.

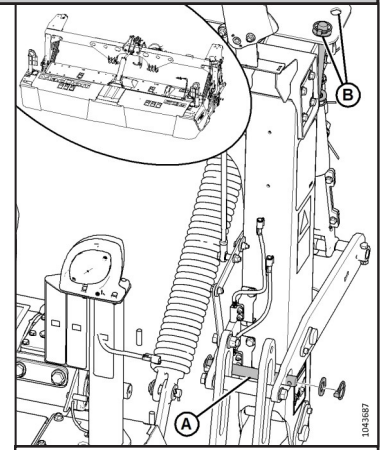

Lock Pins – Left Side

1043687

Cutting Height

Hydraulic Center-link (Optional)

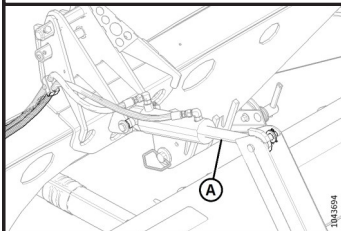

Activate hydraulic cylinder (A) using tractor hydraulic control to adjust header angle.

Mechanical Center-link

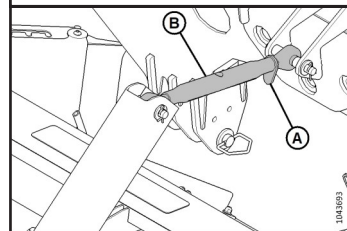

Loosen nut (A) and rotate center-link sleeve (B) to adjust header angle.

1043693

Skid Shoe Up

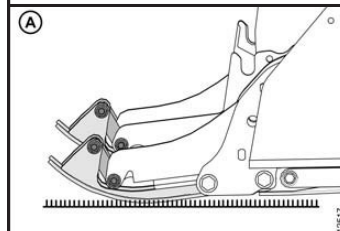

Upper skid shoe position (A): suitable for short stubble or smooth ground

1012517

Skid Shoe Down

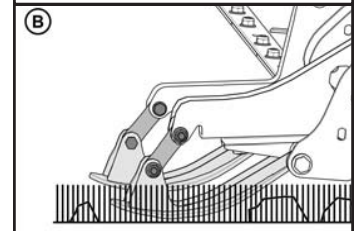

Lower skid shoe position (B): suitable for high stubble, rocks, or cane

Steep angle: suitable for smooth, level, or firm ground

Shallow angle: suitable for rocks, ridges, or loose ground

Windrow Formation

Adjusting Side Deflectors:

1. Loosen locking handle (A).
2. Slide adjuster bar (B) along adjuster plate (C) to the desired deflector position and engage bar (B) into a notch in the adjuster plate.
3. Repeat adjustment on the opposite side.

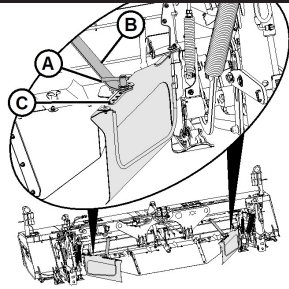

Side Deflectors

Adjusting Conditioner Baffle:

1. Remove lynch pin (A).
2. Pull conditioner baffle adjustment lever (B) inboard and position as follows:
 - Move the lever forward to raise the baffle.
 - Move the lever backward to lower the baffle.
3. Release lever and engage with notched bracket.
4. Secure the lever with lynch pin.

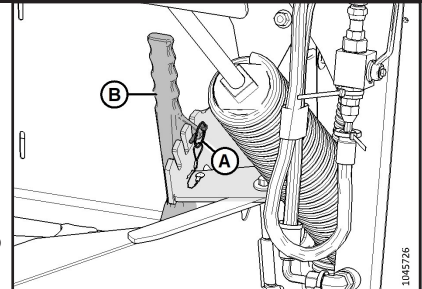

Conditioner Roll Baffle

Float Springs

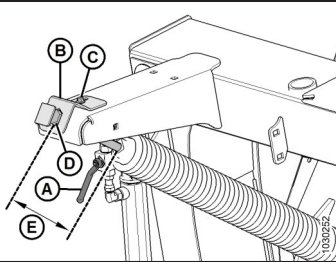

Rocky, ridged, or loose ground
45 kg (100 lb.) float setting

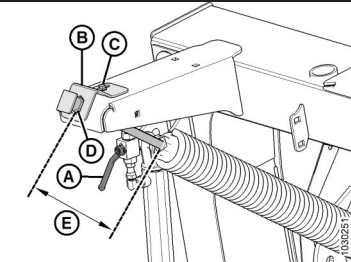

Smooth, level, or firm Ground
55-70 kg (125-150 lb.) float setting

1. The adjust float springs, close lift cylinder valve (A).
2. Remove spring lock plate (B) and lock plate hardware (C).
3. Turn adjuster bolt (D) to adjust measurement (E):
 - Turn bolt (D) clockwise to increase the float.
 - Turn bolt (D) counterclockwise to decrease the float.
4. Install lock plate (B) and hardware (C).

Float Indicator

From the tractor's operator position, the float indicator provides a visible representation of the header ground pressure. When calibrated properly, the float indicator pointer will react to ground pressure as follows:

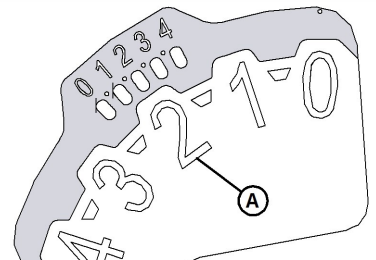

Float Indicator

- **Pointer centered on number 2 (A):** header on level ground in cutting position, normal ground pressure
- **Pointer above number 2:** header on ground, increased ground pressure
- **Pointer below number 2:** header off the ground, decreased ground pressure

Carrier Frame Alignment

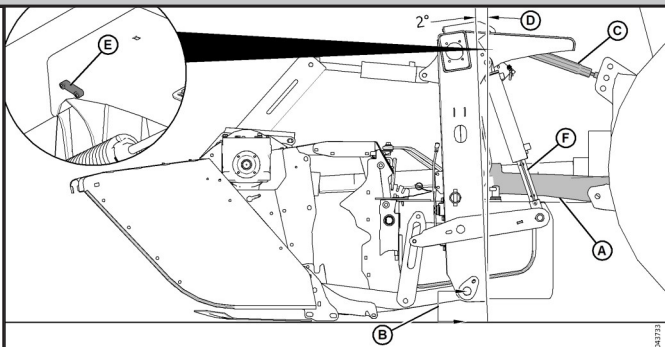

1. Adjust lower hitch arms (A) so dimension (B) between the bottom of the carrier frame and the ground is 184 mm (7.25 in).
NOTE: The cylinders must be lowered onto downstops (F).
2. Adjust the length of top link (C) on the 3-point hitch until carrier frame angle (D) is approximately 2° forward. Use bubble level (E), located on the right side of the carrier frame to set the angle.

Subject to change without notice

Cutterbar

Tips:

- Sharp blades reduce horsepower requirements.
- Install cutterbar deflectors (A) when cutting tall, stemmy crops.
- Remove cutterbar deflectors to reduce debris buildup on the cutterbar.

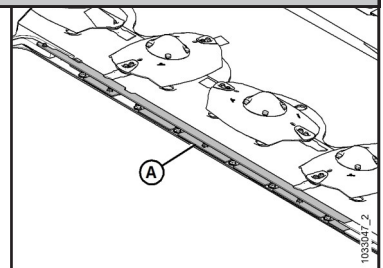

Disc Speed



Light/Thin Crop

800 PTO rpm



Heavy/Tough Crop

1000 PTO rpm