

### Recommended Fluids and Lubricants

Ensure that your machine will operate at top efficiency by using clean fluids and lubricants only.

- Use clean containers to handle all fluids and lubricants.
- Store fluids and lubricants in an area protected from dust, moisture, and other contaminants.

Lubricant	Specification	Description	Use	Capacities
Grease	SAE multi-purpose	High-temperature extreme-pressure (EP) performance grease with 1% max molybdenum disulphide (NLGI Grade 2) lithium base	As required unless otherwise specified	—
		High-temperature extreme-pressure (EP) performance grease with 10% max molybdenum disulphide (NLGI Grade 2) lithium base	Driveline slip-joints	—
Gear Lubricant	SAE 85W-140	API service class GL-5	Knife drive box	1.50 liters (1.6 quarts)
			Main gearbox	2.75 liters (2.9 quarts)
			Completion gearbox	2.25 liters (2.4 quarts)
Hydraulic Oil	Single grade trans-hydraulic oil Viscosity at 60.1 cSt @ 40°C (104°F) Viscosity at 9.5 cSt @ 100°C (212°F) • Recommended brands: • Petro-Canada Duratran • John Deere Hy-Gard J20C • CNH Hy-Tran Ultraction	Lubricant trans / hydraulic oil	Header drive systems reservoir	95.0 liters (25.1 US gallons)
Chain Oil	Viscosity of 100–150 sCt at 40°C (104°F) or mineral oil SAE 20W-50 (no detergents or solvents)	Formulated for wear protection and resistance to foaming.	Reel drive chain	—

### Break-In Inspections

Your machine will need break-in inspections for the first 50 hours of operation. Refer to your operator's manual for complete inspection and adjustment procedures.

Interval	Item	
First 5 Minutes	Check hydraulic oil level in reservoir (check after first run-up and after the hydraulic hoses have filled with oil).	
5 Hours	Check for any loose hardware and tighten it to the specified torque requirements.	
10 Hours	Check the auger drive chain tension.	
	Check the knife drive box mounting bolts.	
	Grease the feed draper drive roller and the idler roller bearings.	
50 Hours	Change the float module gearbox oil.	Change the float module hydraulic oil filter.
	Change the knife drive box lubricant.	Check the gearbox chain tension.
	Lubricate the reel drive chain.	

### Ongoing Maintenance Intervals

Refer to the operator's manual for a comprehensive maintenance schedule and record. Log hours of operation, use the maintenance record, and keep copies of these records.

Following the maintenance schedule will increase your machine's life.

### SETTING HEADER FLOAT AND WING BALANCE

Follow these five steps in order to set the header float and the header wing balance:

#### NOTE:

Read and understand the corresponding section of your operator's manual before setting the header float.

#### Step 1: Preadjustments

- Park the combine on a level surface and ensure that the combine feeder house is level. Use the bubble level on the float module.
- Adjust the header so that the cutterbar is 250 mm (10 in.) (A) off the ground.
- On indicator (B), set the header angle hydraulic cylinder to D.
- On reel arm fore-aft indicator (C), set the reel fore-aft to 6.
- Lower the reel completely, shut down the combine, and remove the key from the combine ignition.

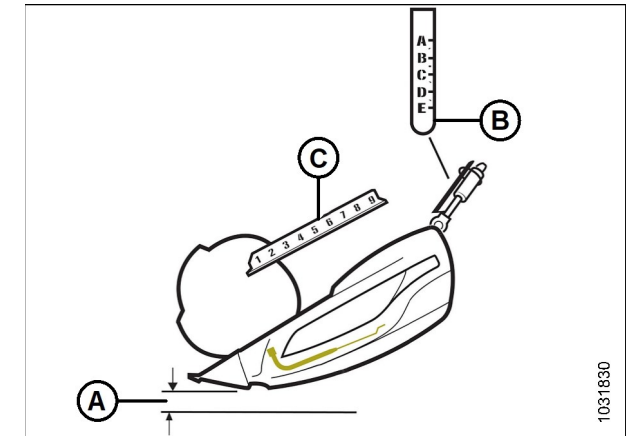

Figure 1: Header – Side View

- Remove linkage cover (A).
- Place both left and right wing lock spring handles (B) in the locked (upper) position. You should hear the locks engage. If not, move the header wings up and down until the locks engage.

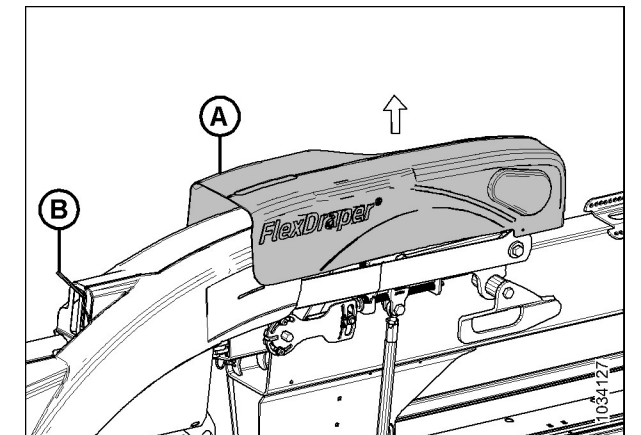

Figure 2: Wing Lock Spring Handle in Locked Position – Left Side Shown

- Place both the left and the right header float locks in unlocked (lowered) position (A).
- Set the stabilizer/transport wheels or contour wheels (if equipped) to the uppermost position.

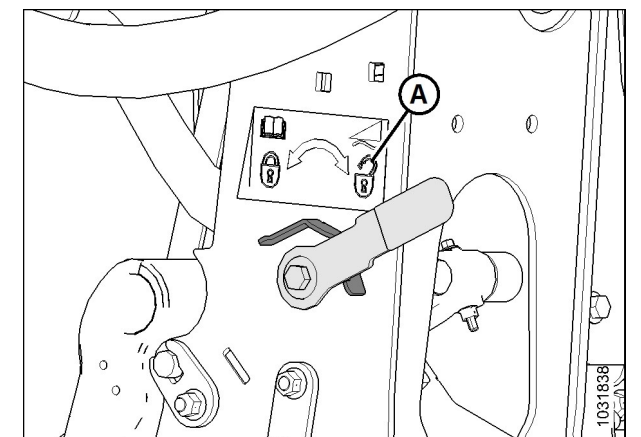

Figure 3: Float Unlocked – Left Side Shown

### Step 2: Checking Header Float

- On the left side of the float module, lift float setting lever (A) by hand to remove slack.
- Fully engage the flat end of multi-tool (B) onto the float setting lever. The multi-tool should be angled toward the front of the float module.  
**NOTE:** Some parts of the illustration have been removed for clarity.
- Pull multi-tool (B) toward the back of the float module until lever (A) is locked into place on last tooth (C) of the lever.
- Repeat Steps a–c on the opposite side of the float module.
- Move the header up and down by hand several times to reduce the effect of friction.

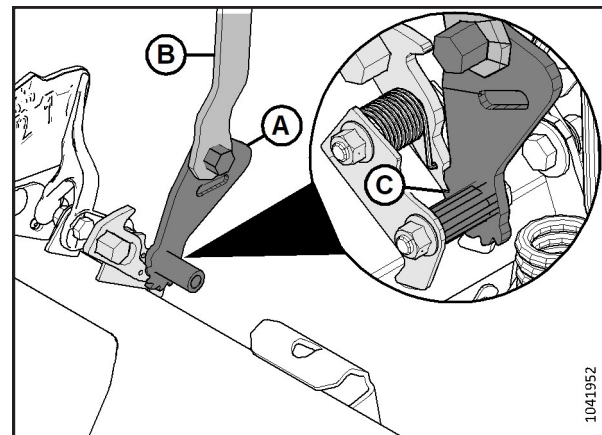

Figure 4: Checking Float – Left Side Shown, View from Rear

- Inspect upper scale on float setting indicator (FSI) (B). Arm (A) on the indicator should point to the number 2.
  - If arm (A) points to a value higher than 2, the float is too heavy.
  - If arm (A) points to a value lower than 2, the float is too light.**NOTE:** Ensure the indicator values are equal on both sides.  
**NOTE:** If necessary, adjust the float values to suit the crop and field conditions. For more information, refer to the operator's manual.

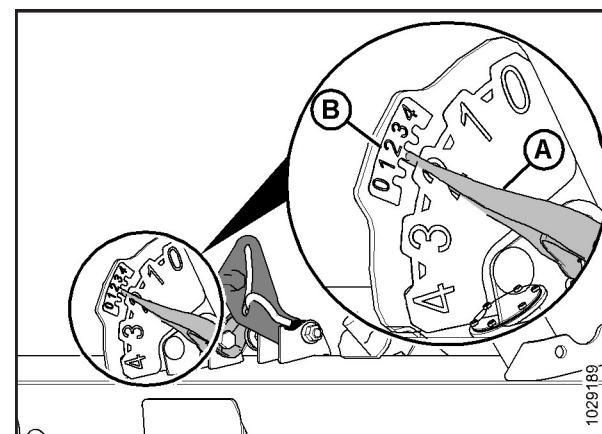

Figure 5: Checking Float – Left Side Shown, View from Rear

### Step 3: Setting Header Float

- Loosen bolts (C), and rotate spring locks (B).
  - To increase header float, turn both adjustment bolts (A) equally clockwise (decreasing the value on the FSI).
  - To decrease header float, turn both adjustment bolts (A) equally counterclockwise (increasing the value on the FSI).
- After adjusting the float, lift the end of the header by hand and recheck the indicator reading.  
**NOTE:** If you cannot achieve the ideal header float setting using the available adjustments, refer to the Operator's Manual for additional float setting options or contact your MacDon Dealer.
- Once the float adjustment is complete, lock adjustment bolts (A) with spring locks (B). Ensure that bolt heads (A) are engaged and tighten bolts (C) to secure the spring locks.

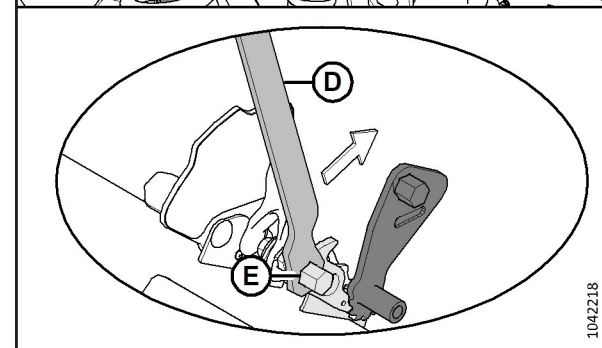
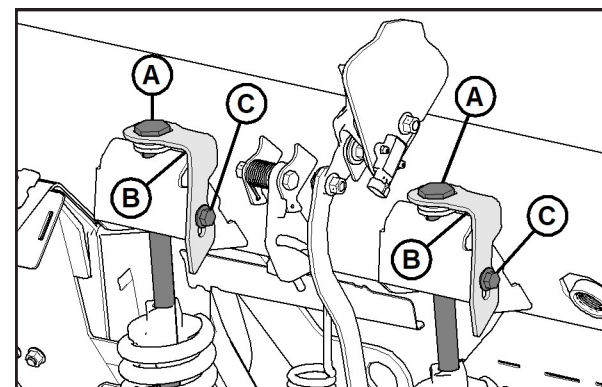

Figure 6: Float Adjustment Bolts – Left Side Shown

**WARNING**  
Release the float setting lever before resuming operation.

- Fully engage multi-tool (D) onto pawl (E) and push it upward to release the float setting lever.

### Step 4: Checking Wing Balance

**NOTE:** Before proceeding to check and adjust the wing balance, set the header float. Refer to Step 3: Setting Header Float for instructions.

- Attach flex checker cable (A) to flex checker cable lock (B).  
**NOTE:** The images shown are from the left side.

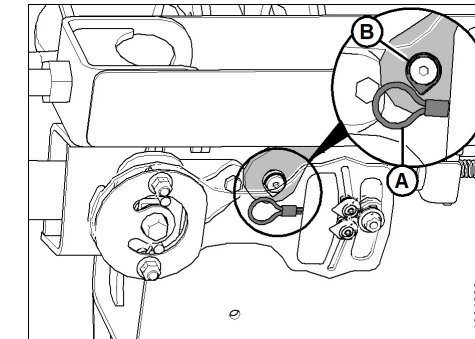

Figure 7: Flex Checker Cable

- On the side that you are adjusting, move spring handle (A) to the lower (UNLOCK) position. Keep the opposite wing locked. You should hear the lock disengage. If not, use multi-tool (B) to rotate the mechanism so that the lock disengages.
- On both sides of the float module, place the header float locks (shown in Figure 3) in the locked position.

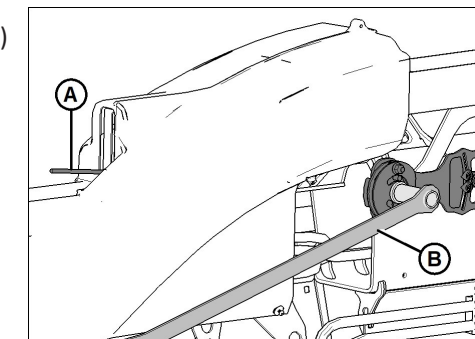

Figure 8: Wing Balance Linkage

- On the flex checker plate, pinch indicators (A) and (B) together with your fingers.
- Use multi-tool (C) to rotate the flex checker plate up until the pin reaches the end of the slot. Lower indicator (B) will move down to give the first reading.
- Use multi-tool (C) to rotate the flex checker plate down until the pin reaches the end of the slot. Upper indicator (A) will move up to give the second reading.
- Refer to Figure 10 and interpret the indicator positions as follows:
  - Condition A – the wing is too light; make the wing heavier.
  - Condition B – the wing is too heavy; make the wing lighter.

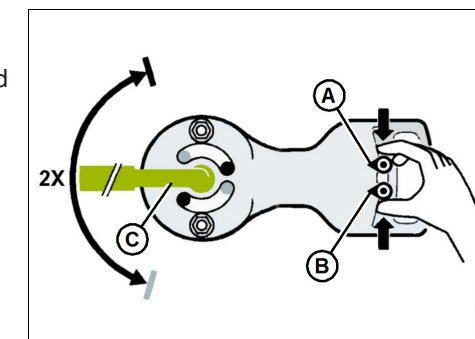

Figure 9: Wing Balance Adjustment

### Step 5: Adjusting Wing Balance

- If the wing is too light (Condition A), make it heavier by turning adjuster bolt (D) to move clevis (E) in direction (F).
- If the wing is too heavy (Condition B), make it lighter by turning adjuster bolt (D) to move clevis (E) in direction (G).
- Recheck the wing balance. Adjust the wing until it is balanced (Condition C).
- Move the spring handle to the upper (LOCK) position.
- If the lock does not engage, move the wing up and down with the multi-tool until it locks.
- Detach the flex checker cable from the flex checker lock.
- Repeat this step on the other side.
- Return the multi-tool to its storage location and reinstall the linkage cover.

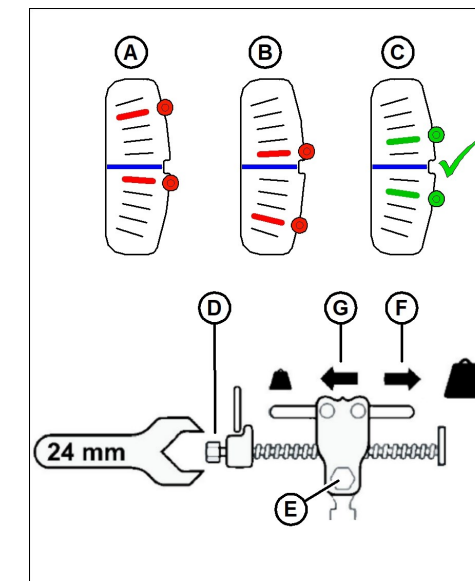

Figure 10: Wing Balance Adjustment