

CONDENSER INSTALLATION INSTRUCTIONS

The condenser has been shipped with an upgrade kit to provide a more durable outlet port configuration. This involves installation of a hose between the outlet port and the receiver/drier.

IMPORTANT: Service on air conditioning system must be performed by a qualified technician who is properly trained in the service of R134a systems.



Use caution when handling the condenser. Painful cuts can be inflicted by the fins.

Take care not to bend any tubes or fins. Bent tubes may result in leaks. Bent fins greatly reduce the air flow. If any fins do become bent, straighten with the proper tool.



CAUTION: Refrigerant R134a must be handled with care to avoid danger. Liquid refrigerant can cause frostbite if allowed to contact the skin or blindness if allowed to contact the eyes. Eye protection should be worn at all times when servicing an air conditioning system. Do not discharge refrigerant into the atmosphere and particularly not into an enclosed area. Vapours may concentrate near the floor or low spots and displace the oxygen available for breathing, causing suffocation. Do not handle damp refrigerant containers with bare hands while charging a system since frost will form on the container, which could cause the hand to be frozen to the container. Gloves should be worn when handling containers or connecting and disconnecting service gauge hoses from the refrigerant source or the air conditioning system. Do not heat refrigerant containers above 50° C (125° F) or place close to an open flame since pressure build-up beyond this temperature is extremely dangerous. Store refrigerant containers in a cool place away from fire risk and sources of direct heat. Handle containers very carefully. Dropping these can damage containers and valves.

1. Run the compressor for 10 minutes with the engine at idle, then check the oil level in the compressor as follows: **NOTE:** If running the compressor is not possible due to low refrigerant charge, this procedure will be performed in step 8 b).
 - a) Recover all refrigerant from the system, slowly so as not to lose any oil.
 - b) Remove oil filler plug. Using a socket wrench on the armature retaining nut, turn the shaft clockwise until the counterweight is centered on the 2 o'clock position as shown in Figure 1.
 - c) Make or obtain a compressor oil dipstick like the one shown in Figure 2. Insert the dipstick up to the stop, with the stop angle pointing to the top of the compressor as shown.
NOTE: If compressor is not mounted in windrower, measurement must be taken with compressor level and rotated 60° as shown in Figure 1.
 - d) Remove dipstick and count the number of notches covered by oil. Between 8 and 10 notches covered indicates correct level. Add or drain oil as required.
 - e) Re-install oil filler plug. Seat and O-ring must be clean and not damaged. Torque to 11 to 18 ft.lbs. (15 to 25 N-m).

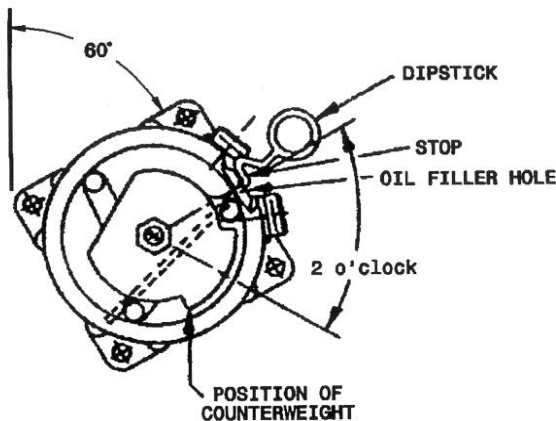

Figure 1

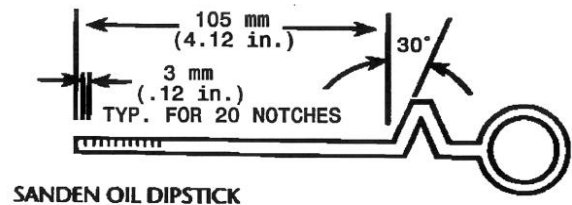

Figure 2

FORM 46298
December 12, 1996

2. Remove the old condenser.
3. Install new condenser.
4. Install a new receiver/drier with hoses as shown in Figure 4. New O-rings are supplied. Note that drier is now located on opposite side of mount.

NOTES:

- Because of its moisture absorbing characteristics, the receiver/drier inlet and outlet connections must remain capped and hoses must not be attached until **immediately** before evacuation procedure.
- Brush refrigerant oil on all refrigerant line O-rings and tube ends immediately before assembly.
- Never attempt to tighten or loosen a fitting with a single wrench. A second wrench is needed to hold the opposing tube or component in a stable position. Fragile components such as light metal tubes will be irreparably damaged if subjected to twisting stresses from a single wrench.
- A/C hoses have an inner nylon barrier which is susceptible to kinking. Care must be taken during the assembly process not to kink hoses. Hoses that have been kinked must not be used.

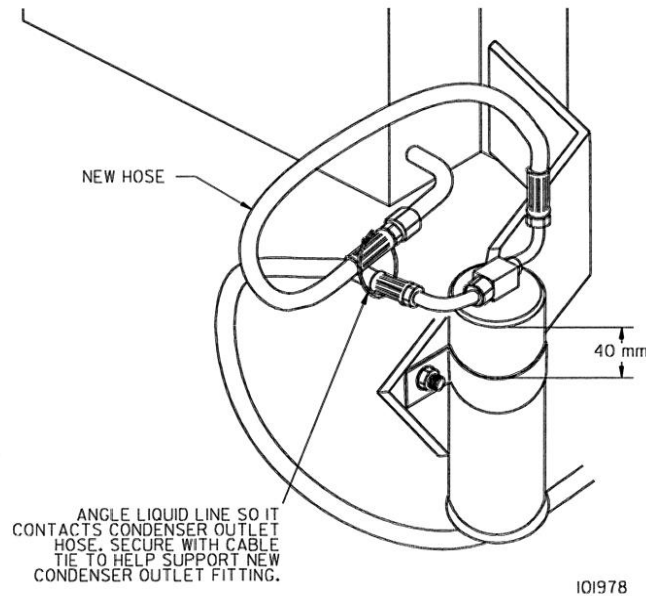

Figure 4

- Assembly torques: (**Do not** exceed high limits)

Receiver/drier and outlet from condenser	11 - 13 ft.lbs. (15 - 17.5 N·m)
Inlet to condenser	15 - 20 ft.lbs. (20.5 - 27 N·m)
Low pressure switch	9 - 11 ft.lbs. (12.2 - 15 N·m)
Evaporator to expansion valve (2 fittings)	15 - 20 ft.lbs. (20.5 - 27 N·m)
Expansion valve suction	21 - 27 ft.lbs. (28.5 - 36.5 N·m)
Expansion valve liquid in	11 - 13 ft.lbs. (15 - 17.5 N·m)
Compressor suction	21 - 27 ft.lbs. (28.5 - 36.5 N·m)
Compressor discharge	15 - 20 ft.lbs. (20.5 - 27 N·m)

5. Secure hoses with nylon tie as shown to prevent excessive vibration of condenser outlet.

6. A/C EVACUATION PROCEDURE:

- a) Connect the charging station. Start evacuation and carefully observe the vacuum scale on the low pressure gauge. If 710 mm (28 inches) of HG vacuum cannot be obtained in less than five minutes, a severe leak exists. If so, check for leak as detailed in step 6 b). If proper vacuum is obtained proceed with step 6 c).
- b) To locate a leak:
 - Pressurize the system with 1035 kPa (150 psi) dry nitrogen. Use a soap solution at fittings and joints to locate leaks. Discharge the system slowly to prevent removing oil from the compressor.
 - If the leak cannot be detected per the above, pressurize the system with 0.45 kg (1 lb.) of R134a. Check for leaks using a calibrated electronic halogen leak detector. Run the probe completely and slowly (no faster than 25 mm/second) around hoses, connections and cores. Correct all leaks before proceeding. Recover the R134a in a reusable container designated for R134a. Do not mix R134a with other refrigerants/products. Discharge the system slowly to prevent removing oil from the compressor.
 - Begin evacuation procedure again. **IMPORTANT:** Never connect the vacuum pump to a system with a static pressure of more than 10 psi. Discharge the system per above before evacuating.
- c) Continue evacuation for minimum one hour.
- d) After evacuation is complete and pump is shut off, wait at least 2 minutes, then check the vacuum reading on the low pressure gauge. A good system will maintain the original vacuum.

7. A/C CHARGING PROCEDURE:

NOTE: Keep charging lines as short as possible to reduce losses of refrigerant when disconnecting charging lines.

- a) Install 1.36 kg (3.00 lbs) refrigerant into the high pressure port at the compressor. Suction side port must be closed to prevent oil from being flushed out of the compressor. To compensate for the new receiver/drier, and any other components replaced, add oil as follows:

COMPONENT BEING REPLACED	TYPICAL OIL AMOUNT	
	fl. oz.	cc
Receiver/Drier	2.0	60
Condenser	1.0	30
Evaporator	2.0	60
Hoses	1.0	30

- b) Check for leaks using a calibrated electronic halogen leak detector. Run the probe completely and slowly (no faster than 25 mm/second) around hoses, connections and cores. Correct all leaks before proceeding.
- c) If the system needs to be discharged of its R134a, recover the R134a in a reusable container designated for R134a. Do not mix R134a with other refrigerants/products. Discharge the system slowly to prevent removing oil from the compressor. Never vent the R134a into the atmosphere.

8. A/C PERFORMANCE TEST:

Refer to Operator's Manual, A/C Maintenance- Service section for Diagnostic Troubleshooting Chart.

- a) Before operating the A/C system for the first time, turn blower switch to "OFF". Turn A/C temperature control switch to maximum cooling. Start engine and operate at low idle. Click blower switch from "OFF" to "LOW" for one second, then back to "OFF" for 5 to 10 seconds. Repeat this cycle ten times to distribute the oil throughout the system. Check that compressor clutch engages when blower is on (blower switch positions 1,2 & 3) and disengages when blower switch is "OFF".
NOTE: It is recommended that the blower switch ten repetition procedure be performed by the operator whenever the machine is first started after storage for more than one week.
- b) If compressor oil level was not checked per step 1 above, do so now and repeat evacuation (for one hour) and charging procedure.

8. A/C PERFORMANCE TEST: (continued)

c) Operate engine at maximum RPM and turn blower switch to highest speed (temperature control switch should still be at maximum capacity). Measure the ambient temperature around the machine. Place a temperature probe at the louvre outlet and in the evaporator core as shown in Figure 5.

BE CAREFUL NOT TO DAMAGE THERMOSTAT CAPILLARY WHEN INSTALLING TEMPERATURE PROBE

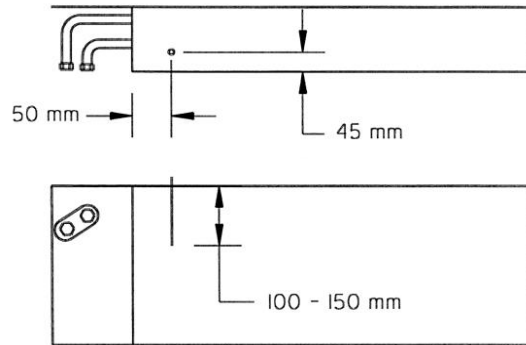

Figure 5

d) Check that compressor maximum discharge pressures are within the normal range shown in graph, Figure 6. The compressor minimum suction pressure will vary with ambient temperature but should be in the range of 10 to 20 psi under normal operating ambients. At 50° F ambient, the minimum suction pressure must not be below 4 psi.

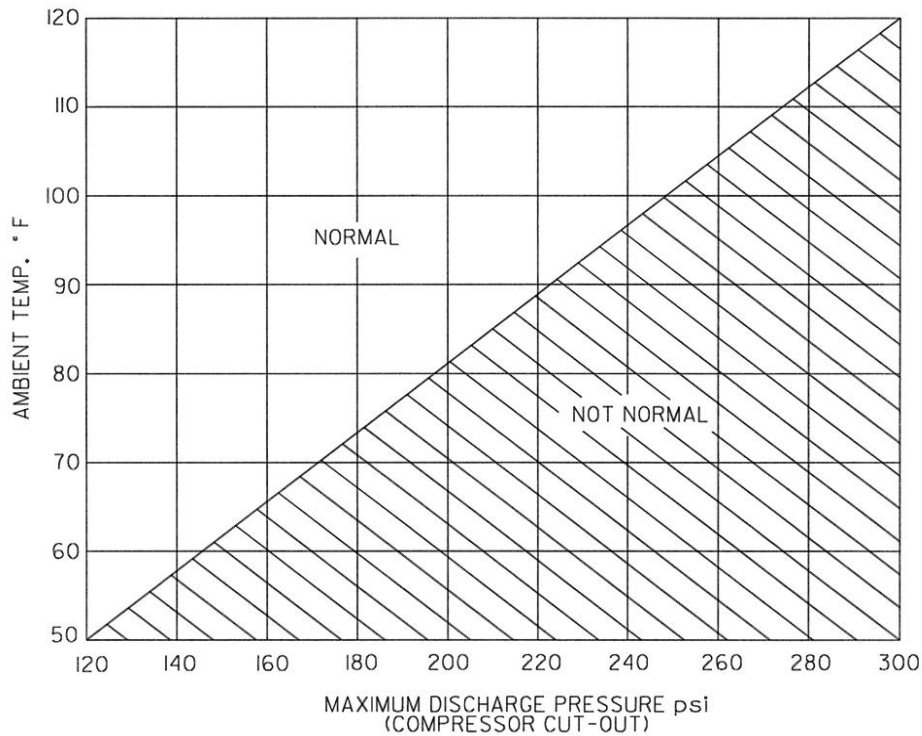

Figure 6

- e) The evaporator core temperature must go down to 30-36° F. If ambient temperature is below 25° C (77° F), louvre discharge air must be below 10° C (50° F). If the ambient temperature is 25° C (77° F) or higher, louvre discharge air temperature must be at least 14-17° C (25-30° F) below ambient temperatures.
- f) Inspect the high side of the system. The compressor discharge line should be hot to the touch. The liquid line (line between the condenser and expansion valve) should feel warm to the touch. Inspect the low side (line between the evaporator and compressor inlet). It should be cold to the touch but without excessive sweating or frosting. Some light sweating is normal.
- g) Turn the cooling control switch to the "OFF" position. The compressor clutch should disengage.
- h) If no further service is required, disconnect the charging station.
- i) Blow off the service valve fitting area to dissipate refrigerant and check for valve leaks.
- j) Place the service fitting caps back on the A/C lines.