

# **FM100 Float Module**

In-Cab Side Draper Speed Control Kits (MD #B6208,  
B6670, B6671, 213770, 304295, and 304296)  
Installation Instructions

214854 Revision B  
Original Instruction

FM100 Float Module

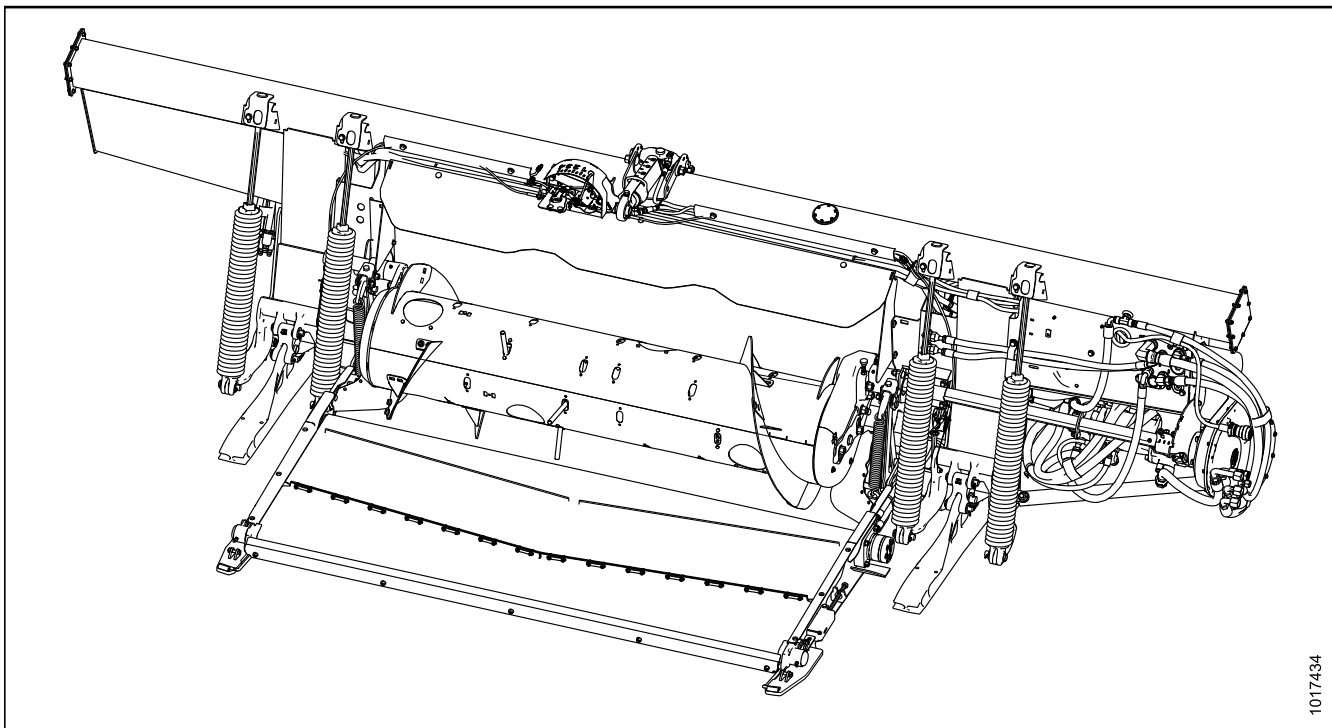

1017434

Published in October 2018

# Introduction

The In-Cab Side Draper Speed Control kits (MD #B6208, B6670, B6671, 213770, 304295, and 304296) allow the Operator to control side draper speed from the combine cab. These kits can be installed on the MacDon FM100 Float Module. Refer to the table below for the kit appropriate for your combine. Only one of the kits below is required for each combine.

Combine	Kit Part Number	Description
Case or New Holland	B6670 or 304295 <sup>1</sup>	The control panel is mounted on the monitor support rail. <b>NOTE:</b> Early Case models that don't have this support rail will require the generic kit (MD #B6671 or 304296) instead.
John Deere	B6208 or 213770 <sup>2</sup>	The control panel is mounted on the armrest.
Generic (all other combines)	B6671 or 304296 <sup>3</sup>	The control panel is mounted on a suction cup assembly.

This document explains how to install the flow control valve, control panel, and electrical connections. The Operator will be able to control side draper speed from the cab **ONLY** if the supplied control panel is installed and power is provided by the combine.

A list of parts included in the kit is provided in Chapter *2 Parts Lists, page 5*.

## **Installation time**

Installation time for this kit is approximately 1 hour.

## **Conventions**

The following conventions are used in this document:

- Right and left are determined from the operator's position. The front of the float module and header is the side that faces the crop; the back is the side that connects to the combine.
- Unless otherwise noted, use the standard torque values provided in the header operator's manual and technical manual.

## **NOTE:**

Keep your MacDon publications up-to-date. The most current version of this instruction can be downloaded from our Dealer-only site (<https://portal.macdon.com>) (login required).

## **NOTE:**

This document is currently available in English only.

- 
1. These kits are the same. B6670 can be ordered from MacDon Whole Goods, while 304295 can be ordered from MacDon Parts.
  2. These kits are the same. B6208 can be ordered from MacDon Whole Goods, while 213770 can be ordered from MacDon Parts.
  3. These kits are the same. B6671 can be ordered from MacDon Whole Goods, while 304296 can be ordered from MacDon Parts.

## List of Revisions

At MacDon, we're continuously making improvements, and occasionally these improvements affect product documentation. The following list provides an account of major changes from the previous version of this document.

Summary of Change	Location
Revision A not published.	—

## TABLE OF CONTENTS

---

Introduction.....	i
List of Revisions .....	ii
<b>Chapter 1: Safety .....</b>	<b>1</b>
1.1 Signal Words .....	1
1.2 General Safety.....	2
<b>Chapter 2: Parts Lists .....</b>	<b>5</b>
2.1 Case New Holland Parts.....	6
2.2 John Deere Parts .....	8
2.3 Generic Parts .....	10
<b>Chapter 3: Installation Instructions .....</b>	<b>13</b>
3.1 Installing Flow Control Valve .....	13
3.2 Installing Control Panel.....	17
3.2.1 Installing Control Panel – Case New Holland .....	17
3.2.2 Installing Control Panel – John Deere S6 Series, T6 Series, and Earlier .....	19
3.2.3 Installing Control Panel – John Deere S7 and T7 Series.....	20
3.2.4 Installing Control Panel – Generic.....	21
3.3 Installing Cab Harnesses .....	23
3.3.1 Installing Cab Harnesses – Case New Holland .....	23
3.3.2 Installing Cab Harnesses – CLAAS 500 Series .....	25
3.3.3 Installing Cab Harnesses – CLAAS 700 Series .....	29
3.3.4 Connecting Cab Harnesses – Challenger, Gleaner, John Deere, and Massey Ferguson .....	35
<b>Chapter 4: Diagnosing a Failed Side Draper Speed Control .....</b>	<b>39</b>



# 1 Safety

## 1.1 Signal Words

Three signal words, **DANGER**, **WARNING**, and **CAUTION**, are used to alert you to hazardous situations. Two signal words, **IMPORTANT** and **NOTE**, identify non-safety related information. Signal words are selected using the following guidelines:

### **DANGER**

Indicates an imminently hazardous situation that, if not avoided, will result in death or serious injury.

### **WARNING**

Indicates a potentially hazardous situation that, if not avoided, could result in death or serious injury. It may also be used to alert against unsafe practices.

### **CAUTION**

Indicates a potentially hazardous situation that, if not avoided, may result in minor or moderate injury. It may be used to alert against unsafe practices.

### **IMPORTANT:**

Indicates a situation that, if not avoided, could result in a malfunction or damage to the machine.

### **NOTE:**

Provides additional nonessential information or advice.

## 1.2 General Safety

### CAUTION

The following are general farm safety precautions that should be part of your operating procedure for all types of machinery.

Protect yourself.

- When assembling, operating, and servicing machinery, wear all protective clothing and personal safety devices that could be necessary for job at hand. Do **NOT** take chances. You may need the following:
  - Hard hat
  - Protective footwear with slip-resistant soles
  - Protective glasses or goggles
  - Heavy gloves
  - Wet weather gear
  - Respirator or filter mask
- Be aware that exposure to loud noises can cause hearing impairment or loss. Wear suitable hearing protection devices such as earmuffs or earplugs to help protect against loud noises.



Figure 1.1: Safety Equipment



Figure 1.2: Safety Equipment

- Provide a first aid kit for use in case of emergencies.
- Keep a fire extinguisher on the machine. Be sure fire extinguisher is properly maintained. Be familiar with its proper use.
- Keep young children away from machinery at all times.
- Be aware that accidents often happen when Operator is tired or in a hurry. Take time to consider safest way. **NEVER** ignore warning signs of fatigue.

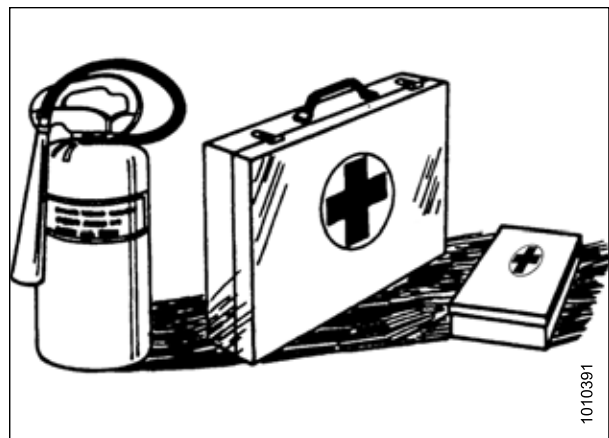

Figure 1.3: Safety Equipment



## SAFETY

- Wear close-fitting clothing and cover long hair. **NEVER** wear dangling items such as scarves or bracelets.
- Keep all shields in place. **NEVER** alter or remove safety equipment. Make sure driveline guards can rotate independently of shaft and can telescope freely.
- Use only service and repair parts made or approved by equipment manufacturer. Substituted parts may not meet strength, design, or safety requirements.



Figure 1.4: Safety around Equipment

- Keep hands, feet, clothing, and hair away from moving parts. **NEVER** attempt to clear obstructions or objects from a machine while engine is running.
- Do **NOT** modify machine. Unauthorized modifications may impair machine function and/or safety. It may also shorten machine's life.
- To avoid bodily injury or death from unexpected startup of machine, **ALWAYS** stop the engine and remove the key from the ignition before leaving the operator's seat for any reason.

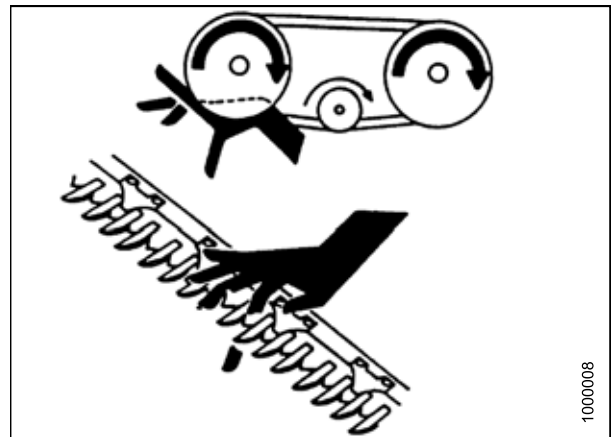

Figure 1.5: Safety around Equipment

- Keep service area clean and dry. Wet or oily floors are slippery. Wet spots can be dangerous when working with electrical equipment. Be sure all electrical outlets and tools are properly grounded.
- Keep work area well lit.
- Keep machinery clean. Straw and chaff on a hot engine is a fire hazard. Do **NOT** allow oil or grease to accumulate on service platforms, ladders, or controls. Clean machines before storage.
- **NEVER** use gasoline, naphtha, or any volatile material for cleaning purposes. These materials may be toxic and/or flammable.
- When storing machinery, cover sharp or extending components to prevent injury from accidental contact.



Figure 1.6: Safety around Equipment



# 2 Parts Lists

# PARTS LISTS

## 2.1 Case New Holland Parts

The parts included in the Case New Holland In-Cab Side Draper Speed Control kits (MD #B6670 and 304295) are as follows:

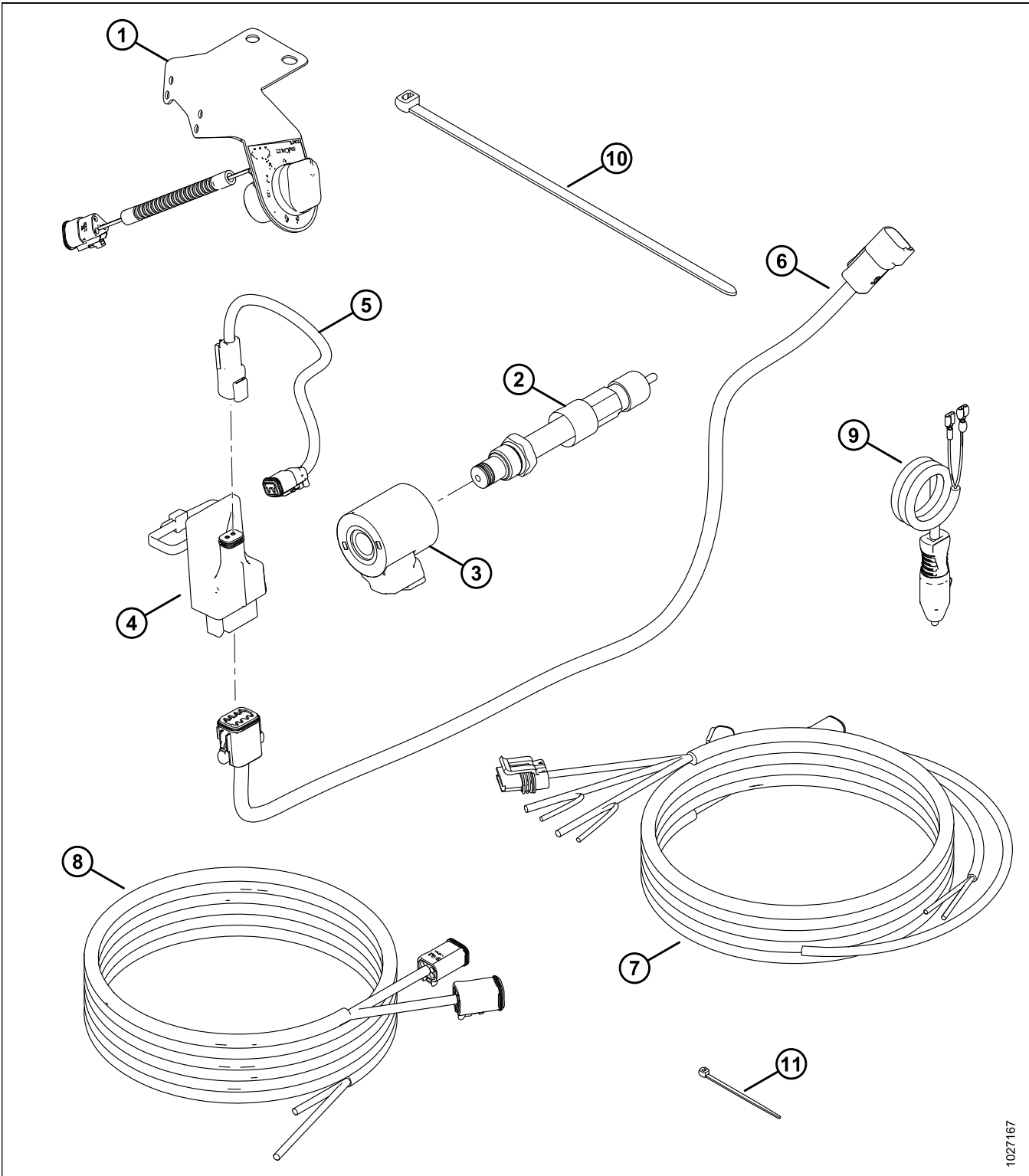

1027167

## PARTS LISTS

<b>Ref</b>	<b>Part Number</b>	<b>Description</b>	<b>Quantity</b>
1	276671	CONTROL PANEL, ICSDSC, CNH	1
2	276631	VALVE – FLOW CONTROL	1
3	209045	COIL – SOLENOID	1
4	213275	VALVE DRIVER – PWM	1
5	213812	HARNESS – SOLENOID	1
6	213813	HARNESS – VALVE DRIVER	1
7	304211	HARNESS – CAB DRAPER EXTENSION	1
8	304210	HARNESS – CAB DRAPER CONTROL	1
9	220570	HARNESS – AUX PWR TO QUICK DISC	1
10	30753	FASTENER – CABLE TIE, BLACK	2
11	16661	FASTENER – CABLE TIE, BLACK	15

## PARTS LISTS

### 2.2 John Deere Parts

The parts included in the John Deere In-Cab Side Draper Speed Control kits (MD #B6208 and 213770) are as follows:

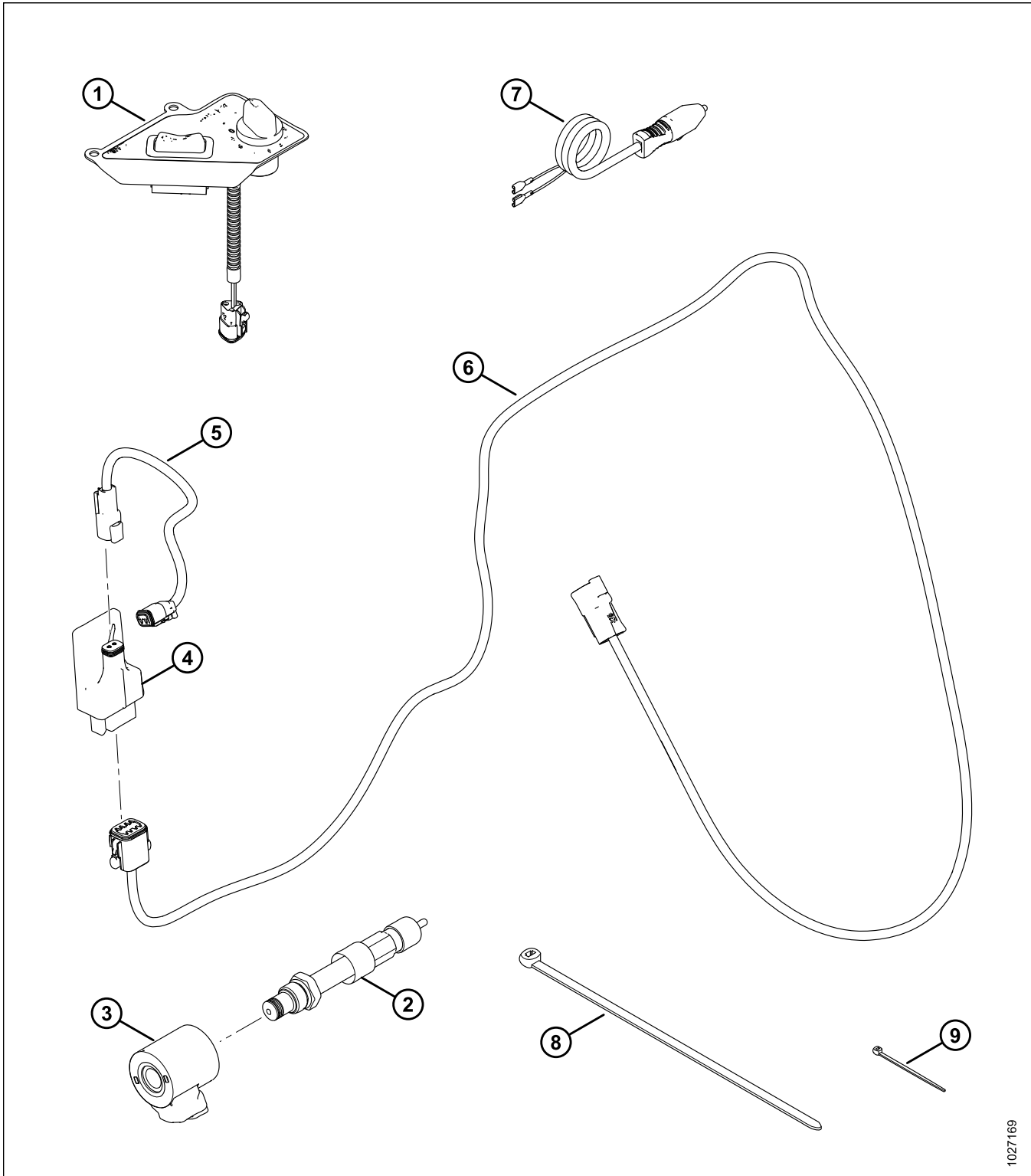

1027169

## PARTS LISTS

<b>Ref</b>	<b>Part Number</b>	<b>Description</b>	<b>Quantity</b>
1	NSS <sup>4</sup>	CONTROL PANEL, ICSDSC, JD	1
2	276631	VALVE – FLOW CONTROL	1
3	209045	COIL – SOLENOID	1
4	213275	VALVE DRIVER – PWM	1
5	213812	HARNESS – SOLENOID	1
6	287894	HARNESS – VALVE DRIVER	1
7	220570	HARNESS – AUX PWR TO QUICK DISC	1
8	30753	FASTENER – CABLE TIE, BLACK	2
9	16661	FASTENER – CABLE TIE, BLACK	15

---

4. Not sold separately.

## PARTS LISTS

### 2.3 Generic Parts

The parts included in the generic In-Cab Side Draper Speed Control kits (MD #B6671 and 304296) are as follows:

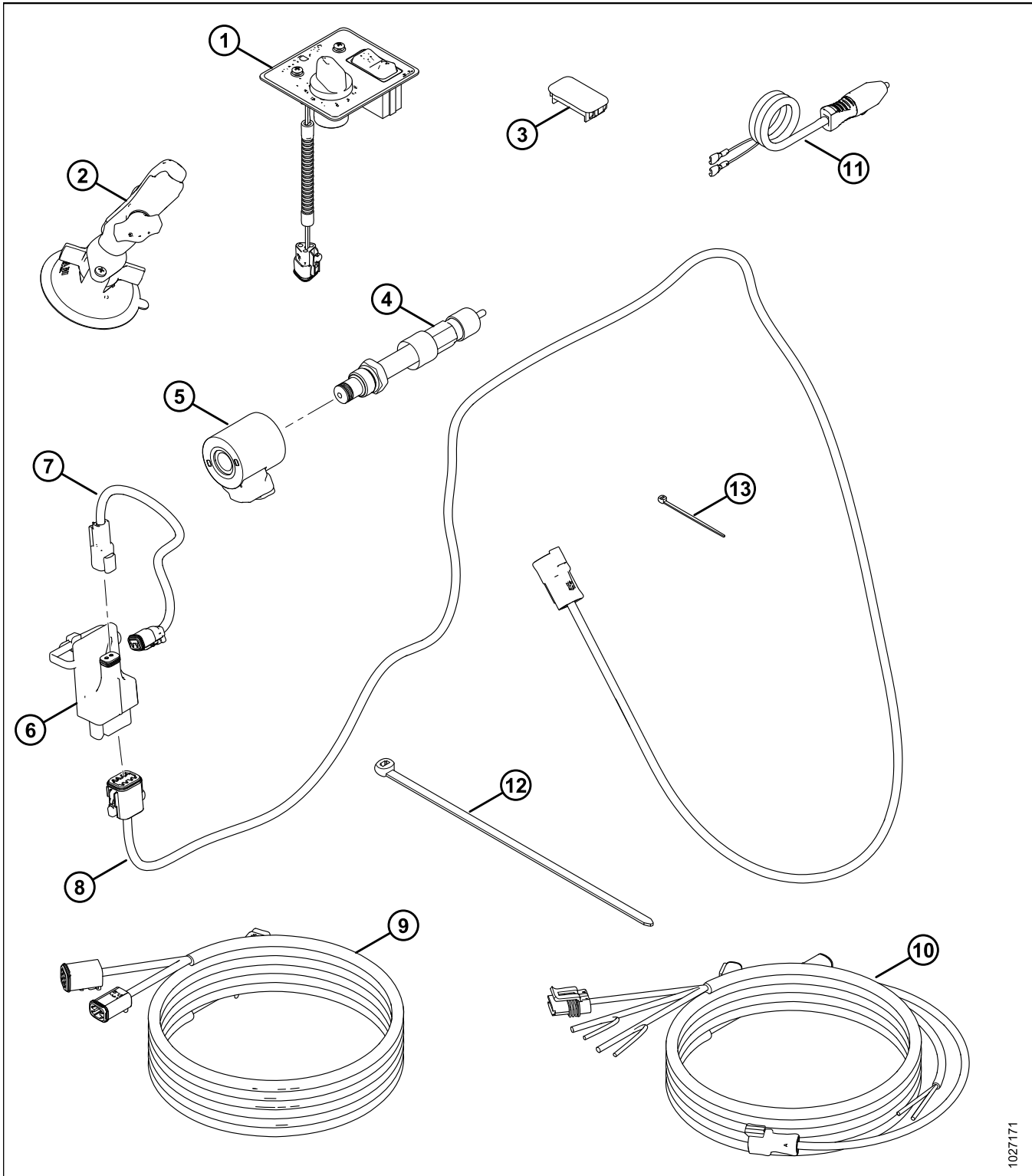

1027171



## PARTS LISTS

Ref	Part Number	Description	Quantity
1	NSS <sup>5</sup>	CONTROL PANEL, ICSDSC, GENERIC	1
2	287859	BASE – SUCTION CUP WITH ARM	1
3	287784	PLUG – PANEL	1
4	276631	VALVE – FLOW CONTROL	1
5	209045	COIL – SOLENOID	1
6	213275	VALVE DRIVER – PWM	1
7	213812	HARNESS – SOLENOID	1
8	287894	HARNESS – VALVE DRIVER	1
9	304211	HARNESS – CAB DRAPER EXTENSION	1
10	304210	HARNESS – CAB DRAPER CONTROL	1
11	220570	HARNESS – AUX PWR TO QUICK DISC	1
12	30753	FASTENER – CABLE TIE, BLACK	2
13	16661	FASTENER – CABLE TIE, BLACK	15

---

5. Not sold separately.



### 3 Installation Instructions

To install the In-Cab Side Draper Speed Control kits, follow these steps:

#### **WARNING**

To avoid bodily injury or death from unexpected startup of machine, always stop engine and remove key before making adjustments to machine.

1. Lower the combine feeder house and tilt the header all the way forward. This will ensure that the electrical harnesses will be installed with sufficient slack.
2. Turn off the engine, and remove the key.
3. Shut off battery disconnect. For instructions, refer to the combine manual.

#### 3.1 Installing Flow Control Valve

To install the flow control valve provided in the kit, follow these steps:

##### **NOTE:**

Some parts have been removed from the illustrations for clarity.

1. Lift cover (A) to access manifold (B) on the float module.
2. Clean area around manual control valve (C).
3. Unscrew lever from manual control valve (C), and then remove valve with a wrench. Discard lever and valve.
4. Loosen elbow fitting (A) at the top of the manifold, and rotate steel line (B) outwards to allow room to install the new flow control valve.

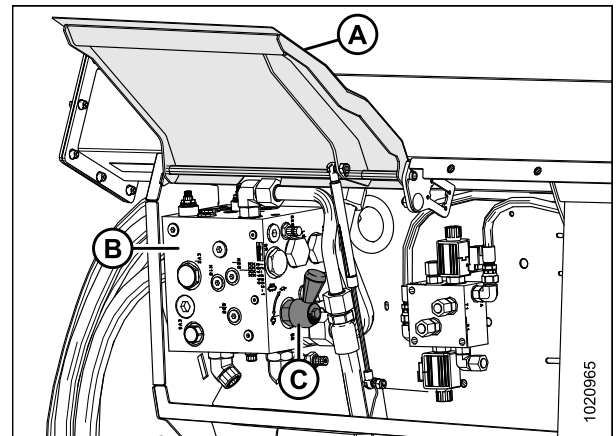

**Figure 3.1: Hydraulic Compartment**

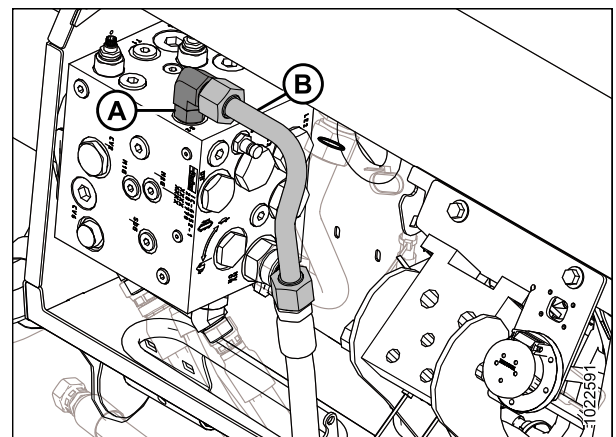

**Figure 3.2: Manifold and Steel Line**

## INSTALLATION INSTRUCTIONS

- Retrieve flow control valve (MD #276631) from kit.
- Remove and retain spacer (A) and retaining nut (B) from the flow control valve, and loosely install solenoid coil (C) (MD #209045) onto the valve.

**NOTE:**

Do **NOT** reinstall spacer (A) and nut (B) at this time.

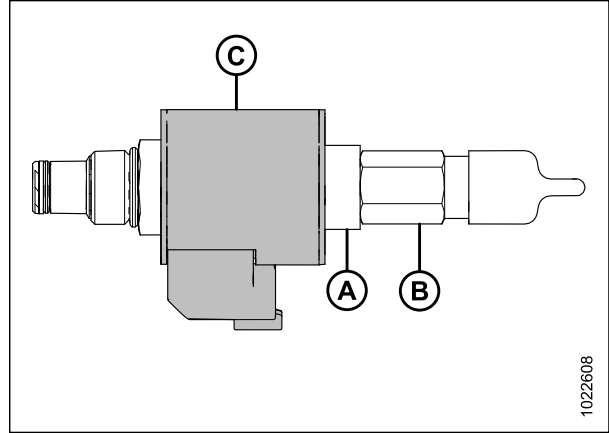

**Figure 3.3: Flow Control Valve and Solenoid Coil**

- Install flow control valve (B) and solenoid coil (A) in place of the old manual flow control valve.
- Torque valve (B) to 21 Nm (16 lbf-ft).

**IMPORTANT:**

Reduced flow control may result if the valve is torqued too tightly into the manifold.

- Reinstall spacer (C) and retaining nut (D) onto flow control valve (B). Make sure the spacer is installed on the outside of solenoid coil (A).

**IMPORTANT:**

Installing spacer (C) between the coil and the manifold will result in reduced flow control.

- Torque solenoid coil (A) to 7 Nm (5 lbf-ft).
- Fasten valve driver (A) (MD #213275) to the back of the hydraulic compartment using cable tie (MD #30753) (not shown) in holes (B). The cable tie should go through a slot in the back of the valve driver.

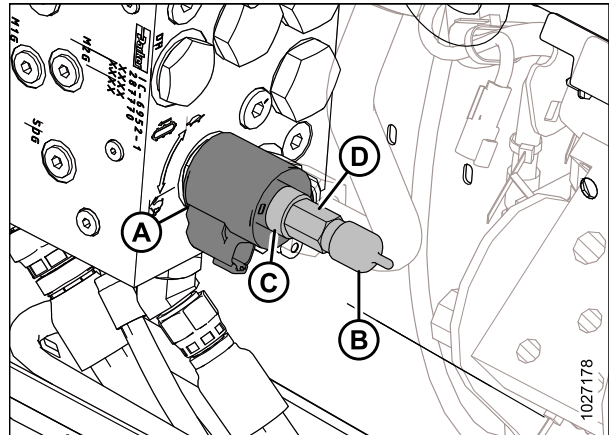

**Figure 3.4: Flow Control Valve**

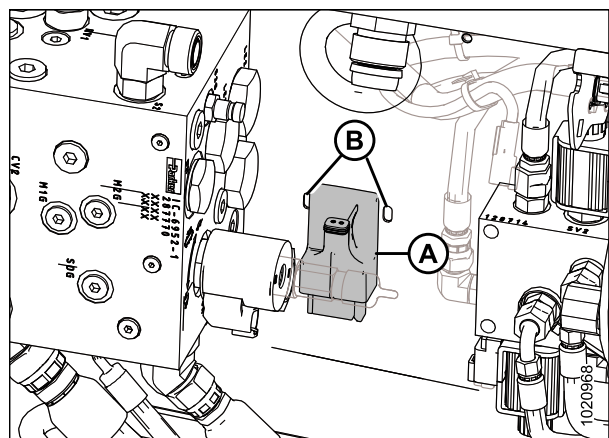

**Figure 3.5: Valve Driver**

## INSTALLATION INSTRUCTIONS

12. Connect solenoid harness (MD #213812) to solenoid and valve driver. Connector P410 (A) connects to the solenoid, and connector C2 (B) connects to the top of the valve driver. Make sure connector C2 is locked in place on the valve driver.

**NOTE:**

The tab on connector C2 (B) should face the front of the header.

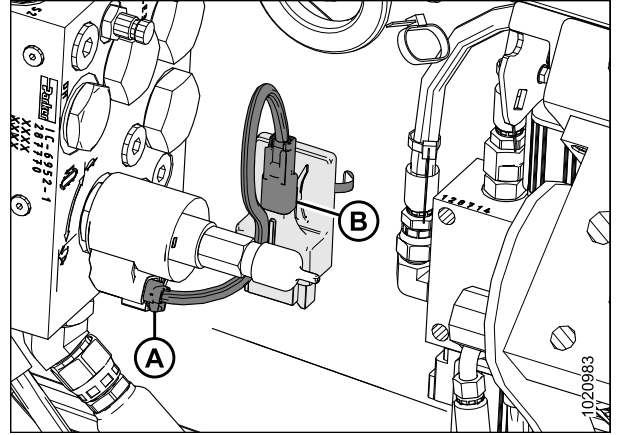

Figure 3.6: Solenoid Harness

13. **Case IH kit (MD #B6670 or 304295):** Plug connector C1 (A) on the valve driver harness (MD #213813) into the bottom of the valve driver.

**NOTE:**

Early Case models that don't have a monitor support rail require the generic kit (MD #B6671 or 304296).

14. **John Deere kit (MD #B6208 or 213770) and Generic kit (MD #B6671 or 304296):** Plug connector C1 (A) on the valve driver harness (MD #287894) into the bottom of the valve driver.

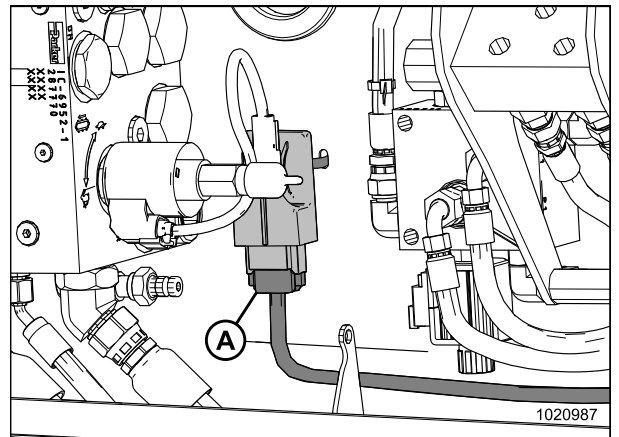

Figure 3.7: Valve Driver Harness

15. Route valve driver harness (A) with completion harness to existing electrical connection (B). Remove shielding as required.
16. Bundle excess harness and secure with cable tie (MD #30753). Position connector C3B (C) near the combine connector location.
17. Use cable ties (MD #16661) and existing adjustable straps to secure harness in place.

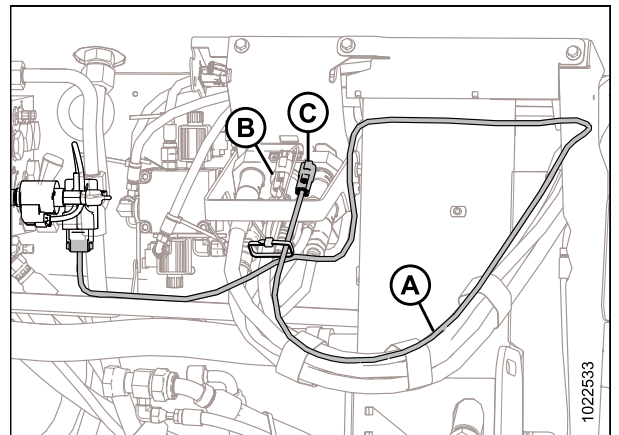

Figure 3.8: Routing Valve Driver Harness – FM100 Configured for John Deere

## INSTALLATION INSTRUCTIONS

18. Rotate steel line (B) back into place and tighten elbow fitting (A) on top of the manifold.

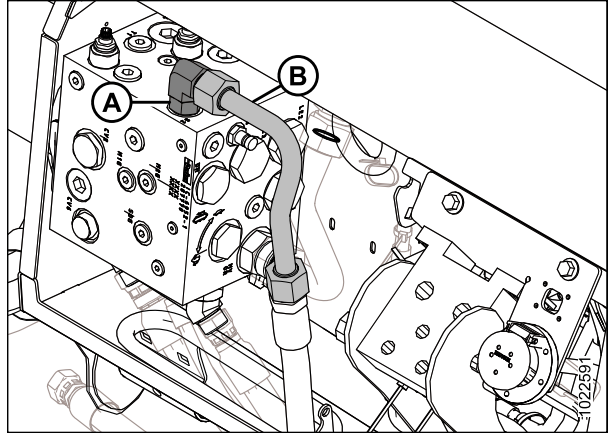

Figure 3.9: Manifold and Steel Line

19. Close cover (A).

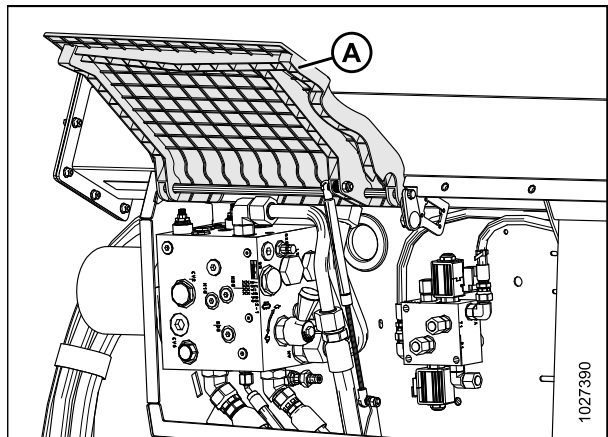

Figure 3.10: Hydraulic Compartment

## INSTALLATION INSTRUCTIONS

### 3.2 Installing Control Panel

The Operator will be able to control side draper speed from the cab **ONLY IF** the supplied control panel is installed and power is provided by the combine. Refer to the instructions below for your kit.

- [3.2.1 Installing Control Panel – Case New Holland, page 17](#)

**NOTE:**

Early Case models without the monitor support rail require the generic kit.

- [3.2.2 Installing Control Panel – John Deere S6 Series, T6 Series, and Earlier, page 19](#)
- [3.2.4 Installing Control Panel – Generic, page 21](#)

#### 3.2.1 Installing Control Panel – Case New Holland

To install the control panel on a Case or New Holland combine, follow these steps:

Control panel (MD #276671) included in the Case New Holland kit (MD #B6670 or 304295) is installed at the end of the monitor support rail of Case and New Holland combines.

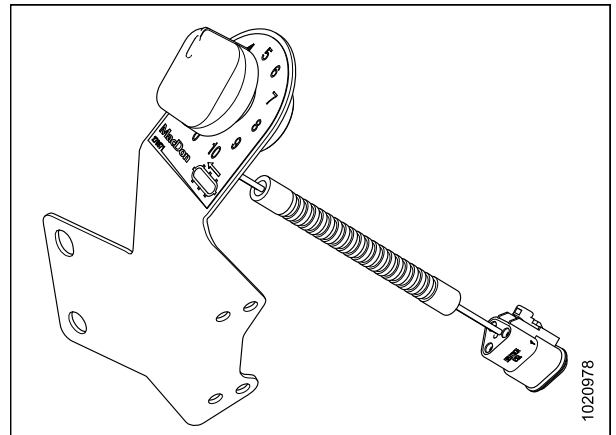

Figure 3.11: Control Panel (MD #276671)

**NOTE:**

Early Case models that don't have the monitor support rail (A) require the generic kit (MD #B6671 or 304296) instead. Refer to [3.2.4 Installing Control Panel – Generic, page 21](#).



Figure 3.12: Monitor Support Rail

## INSTALLATION INSTRUCTIONS

1. Remove and retain hardware (A) from end of monitor support rail (B).

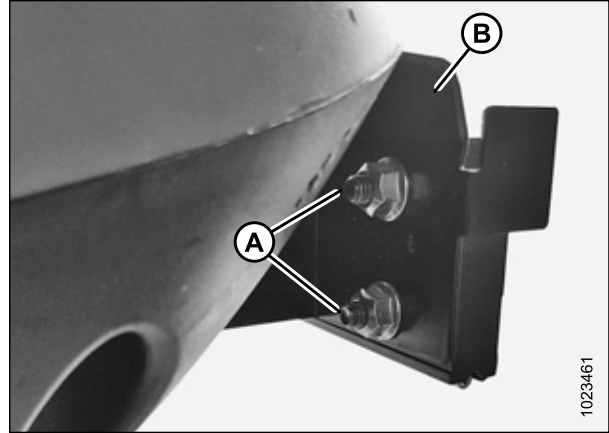

Figure 3.13: Monitor Support Rail

2. Mount control panel (A) to the back of the monitor support rail (B) using existing hardware (C).

**NOTE:**

Installing the panel on the back of the rail will prevent interference with the monitor.

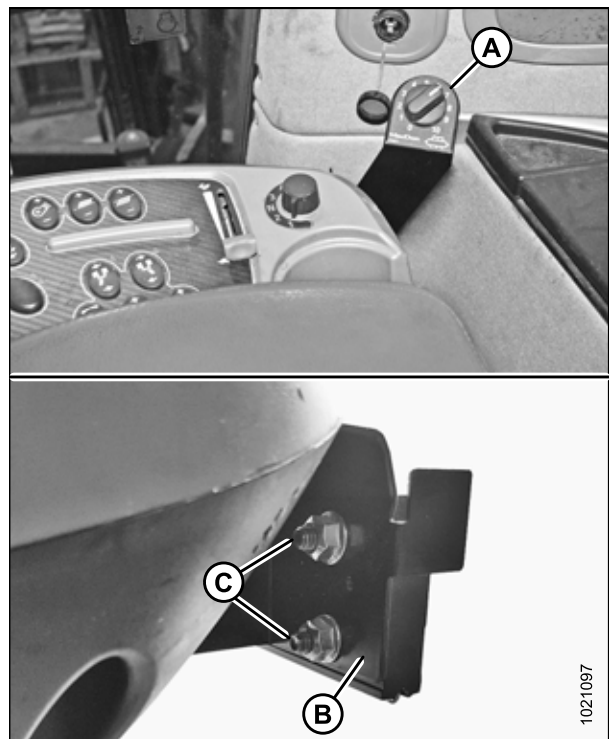

Figure 3.14: Installing Control Panel



## INSTALLATION INSTRUCTIONS

### 3.2.2 Installing Control Panel – John Deere S6 Series, T6 Series, and Earlier

To install the control panel on a John Deere S6 Series, T6 Series, or earlier model combine, follow these steps:

The control panel provided in the John Deere kit is designed for John Deere combines only. To install it, follow these steps:

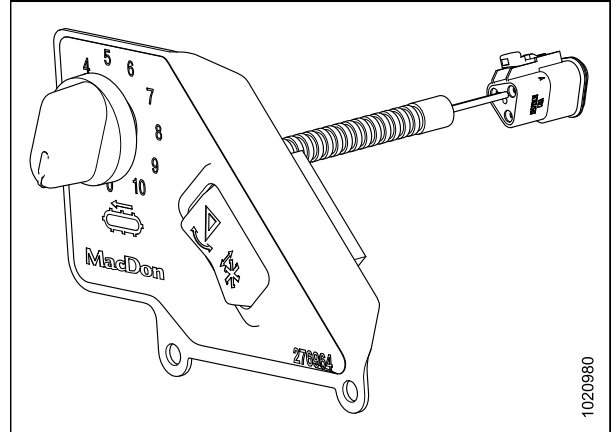

Figure 3.15: John Deere Control Panel

1. Disconnect the cab draper control harness from the existing reel fore-aft / header tilt rocker switch (A).



Figure 3.16: Existing Rocker Switch Support

2. In the combine cab, open the storage compartment on the console.
3. Remove the two screws (A) attaching cover (B) and the existing rocker switch support to the console, and then remove the cover and support. Discard the support.

**NOTE:**

Only the edge of the rocker switch support is visible in the illustration at right. The rest of it is hidden behind the open storage compartment cover.

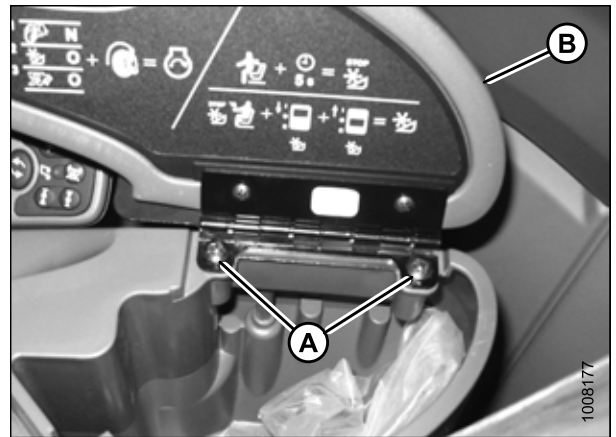

Figure 3.17: Storage Compartment with Open Cover

## INSTALLATION INSTRUCTIONS

4. Position control panel (C) onto console and align the holes in the support with the holes in the console.

### NOTE:

Only the edge of the control panel is visible in the illustration at right. The rest of it is hidden behind the open storage compartment cover.

5. Reinstall cover (B) and secure in place with existing screws (A).

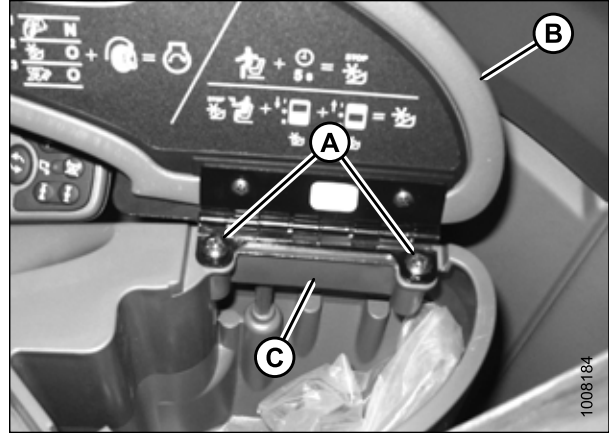

Figure 3.18: Storage Compartment with Open Cover

6. Close cover (B) and ensure control panel (A) is secure.



Figure 3.19: Control Panel Installed

### 3.2.3 Installing Control Panel – John Deere S7 and T7 Series

To install the control panel on a John Deere S7 or T7 Series combine, follow these steps:

The control panel provided in the John Deere kit is designed for John Deere combines only. To install it, follow these steps:

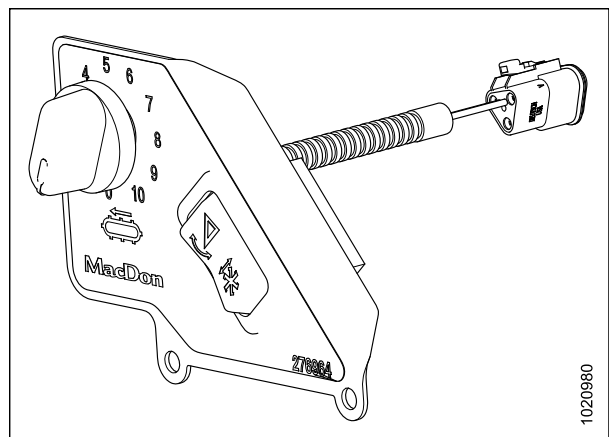

Figure 3.20: John Deere Control Panel

## INSTALLATION INSTRUCTIONS

1. Disconnect the cab draper control harness from the existing reel fore-aft / header tilt rocker switch.

**NOTE:**

The rocker switch is not shown in the illustration at right.

2. Remove and retain the hardware securing existing rocker switch support (B) to tilt/draper speed support (A), and then remove and discard the rocker switch support.

**NOTE:**

Depending on what options are installed, the supports may not be installed exactly as shown.



**Figure 3.21: Top View of Armrest and Rocker Switch Support**

3. Install control panel (A) in place of the rocker switch support, using the retained hardware.

**NOTE:**

The rocker switch is not shown in the illustration at right.



**Figure 3.22: Control Panel Installed**

### 3.2.4 Installing Control Panel – Generic

The control panel included in the generic kit (MD #B6671 or 304296) can be installed on all combine models. For instructions, follow these steps:

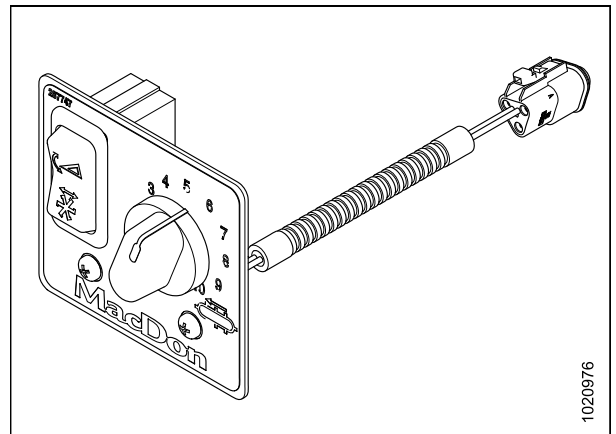

**Figure 3.23: Generic Control Panel**

## INSTALLATION INSTRUCTIONS

1. Attach suction cup base (A) (MD #287859) to ball mount (B) on back of control panel. Tighten using knob (C).

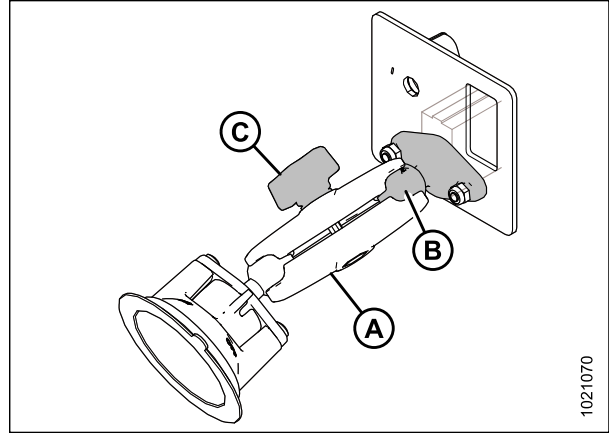

**Figure 3.24: Control Panel and Suction Cup Base**

2. Install the control panel inside the cab by attaching the suction cup (A) to window glass or a smooth surface on the console. Secure in place by locking tab (B) on panel base.

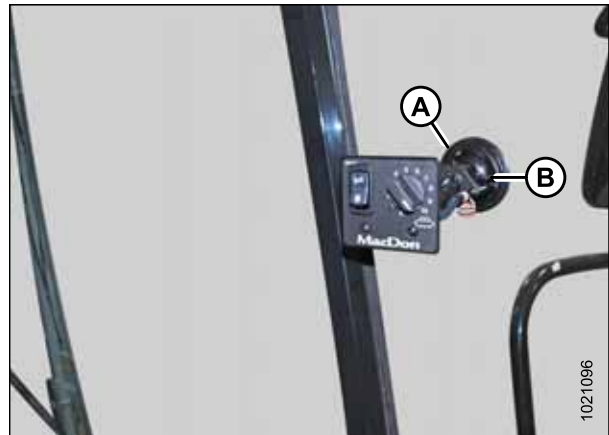

**Figure 3.25: Installing Control Panel**

### 3.3 Installing Cab Harnesses

The cab harnesses run from the float module multicoupler, underneath the combine cab, and up into the cab to the combine console. The specific harness routing varies by combine make.

Challenger, Gleaner, John Deere, and Massey Ferguson combines will already have cab harnesses installed because the harnesses are included in the completion packages for these combines.

Refer to the appropriate instructions for your combine model:

- [3.3.1 Installing Cab Harnesses – Case New Holland, page 23](#)
- [3.3.2 Installing Cab Harnesses – CLAAS 500 Series, page 25](#)
- [3.3.3 Installing Cab Harnesses – CLAAS 700 Series, page 29](#)
- [3.3.4 Connecting Cab Harnesses – Challenger, Gleaner, John Deere, and Massey Ferguson, page 35](#)

#### 3.3.1 Installing Cab Harnesses – Case New Holland

To install cab harnesses on a Case or New Holland combine, follow these steps:

1. Near the multicoupler (A), connect cab draper extension harness (MD #304211) to the float module as follows:
  - Connector C3A – Plug connector C3B (B) on the valve drive harness into connector C3A.
  - Connector C5B – Plug connector C5B into connector C5A on the Case New Holland completion harness.

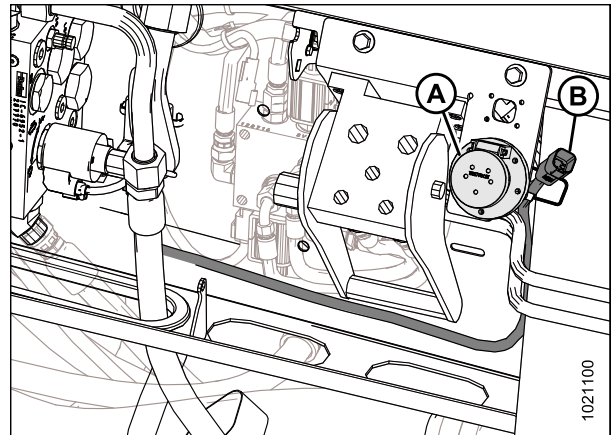

Figure 3.26: Valve Driver Harness Connection

2. Route the cab draper extension harness from the multicoupler, through the cable and hose sock, to grommet (A) on the combine.
3. Route the harness through grommet (A) and into the rotor chamber on the combine, following the white path in the illustration at right.

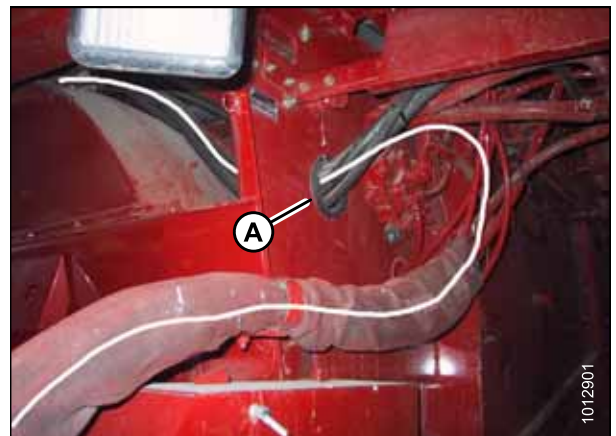

Figure 3.27: Harness Routing into Combine Rotor Chamber

## INSTALLATION INSTRUCTIONS

4. Run the harness across the top of the rotor, following the white path in the illustration at right. Use cable ties (MD #16661) to secure the harness to the hoses.
5. Route the harness out of the rotor chamber and into the combine cab.
6. Inside the cab, connect the cab draper extension harness to the cab draper control harness (MD #304210) as follows:
  - Plug C4B into C4A.
  - Plug C6B into C6A.



Figure 3.28: Harness Routing over Combine Rotor

7. **Generic kit only:** If the combine has a built-in tilt toggle switch on the ground speed lever (GSL), the toggle switch on the control panel is not required. Remove toggle switch (A) from the control panel, and replace with plug (B) (MD #287784).

### NOTE:

The control panel provided in the Case New Holland kit does not include a tilt toggle switch.

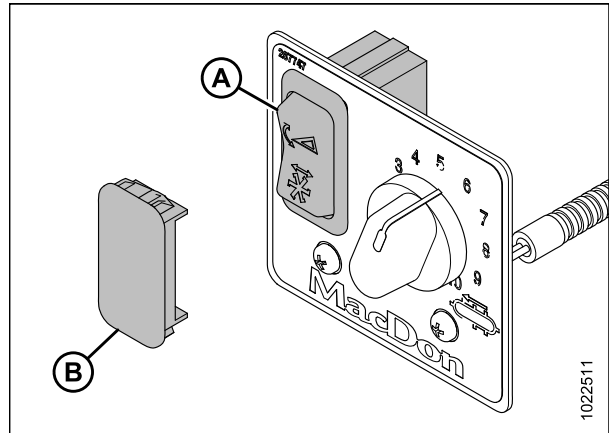

Figure 3.29: Control Panel

8. Connect connector P551 on the cab draper control harness to the control panel potentiometer (A).

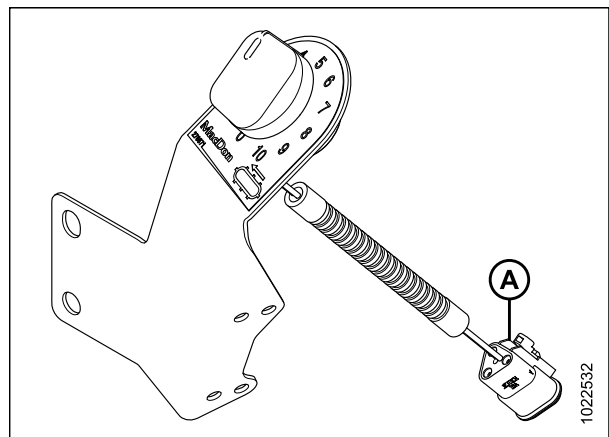

Figure 3.30: Control Panel Potentiometer – Case New Holland Shown

## INSTALLATION INSTRUCTIONS

9. Connect terminals T241 and T251 on the cab draper control harness to the auxiliary power to quick disc harness (A) (MD #220570), and then plug harness (A) into the cigarette lighter.

**IMPORTANT:**

Ensure the port on the combine is switched power, otherwise the In-Cab Side Draper Speed Control kit could drain the combine battery during extended shutdown periods.

**NOTE:**

The cab draper control harness can also be connected at the back of the cigarette lighter using terminals T240-T241 and T250-T251, which will require some disassembly of the cab interior for access.

10. Use cable ties (MD #16661) to secure cab harness in place. Ensure a cable tie is used near the potentiometer to prevent disconnection.
11. Turn on battery disconnect. For instructions, refer to the combine manual.

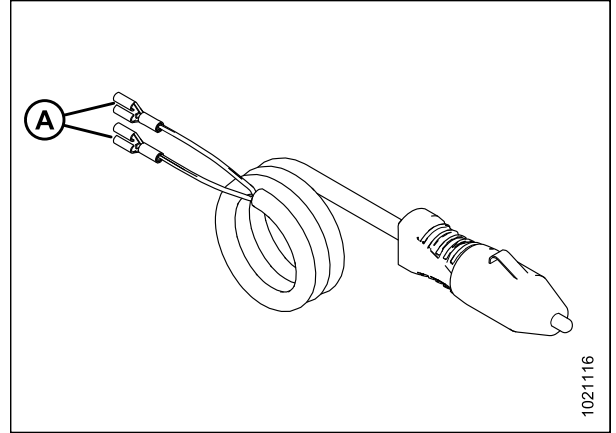

Figure 3.31: Power Adapter (MD #220570)

### 3.3.2 Installing Cab Harnesses – CLAAS 500 Series

To install cab harnesses on a CLAAS 500 Series combine, follow these steps:

1. Near the multicoupler, connect cab draper extension harness (MD #304211) to the float module as follows:
  - Connector C3A – Plug connector C3B on the valve drive harness into connector C3A.
  - Connector C5B – Plug connector C5B into connector C5A on the CLAAS completion harness.

**NOTE:**

Connector C5B does not need to be connected on model year 2018 and newer headers configured for CLAAS combines.

2. Route the cab draper extension harness (A) from the float module multicoupler, along the side of the combine feeder house, underneath the cab, and over to the right side of the combine cab. Place the harness in steel tray (B) on the underside of the cab to prevent it from being damaged.
3. Use cable ties (MD #16661) to secure the cab draper extension harness to the main harness on the left side of the feeder house and under the cab floor.

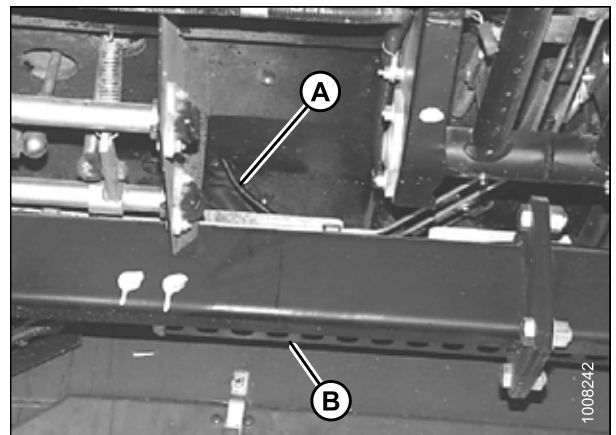

Figure 3.32: Cab Underside

## INSTALLATION INSTRUCTIONS

4. In the cab, remove storage tray (A) from the console.



**Figure 3.33: Console Tray**

5. Remove hex nut (A) and washer from under the combine monitor at the front of the console.

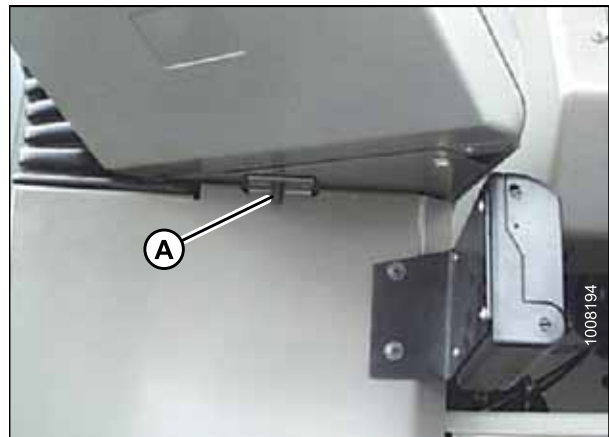

**Figure 3.34: Console Monitor**



## INSTALLATION INSTRUCTIONS

6. Rotate console (A) to access wiring.
7. Remove the plug from the cab floor under the console. Pull the end of the cab draper extension harness into the cab through the hole.
8. Inside the cab, connect the cab draper extension harness to the cab draper control harness (MD #304210) as follows:
  - Plug C4B into C4A.
  - Plug C6B into C6A.

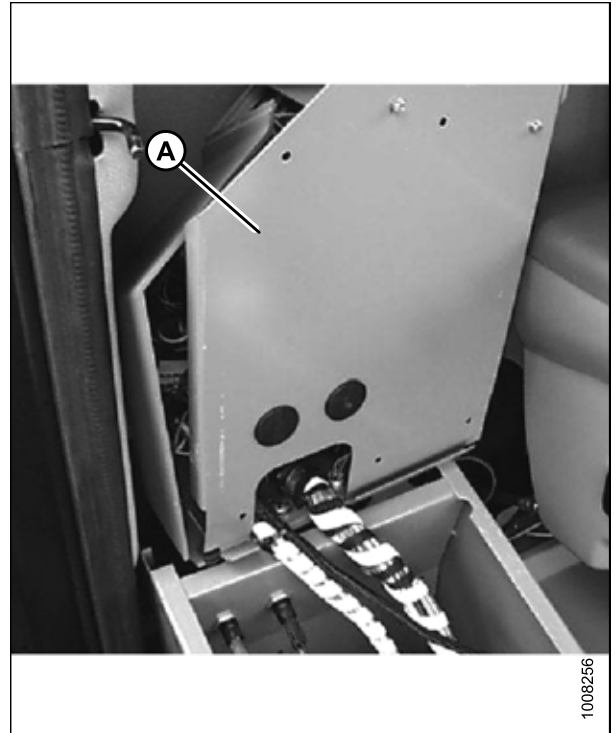

Figure 3.35: Opened Console

9. If the combine has a built-in tilt toggle switch on the GSL, the toggle switch on the control panel is not required. Remove toggle switch (A) from the control panel, and replace with plug (B) (MD #287784).

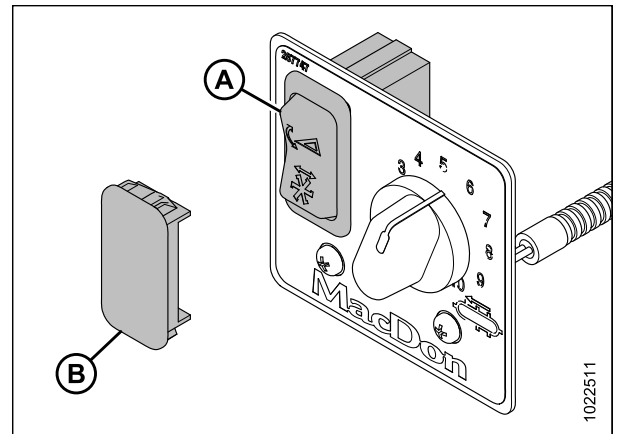

Figure 3.36: Control Panel

## INSTALLATION INSTRUCTIONS

10. Connect connector P551 on the cab draper control harness to the control panel potentiometer (A).

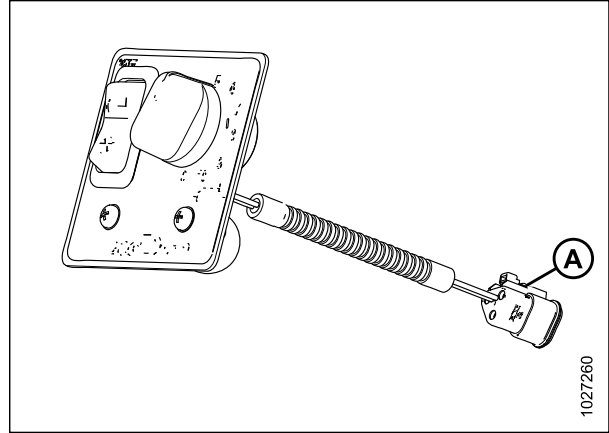

Figure 3.37: Control Panel Potentiometer

11. Connect terminals T241 and T251 on the cab draper control harness to the auxiliary power to quick disc harness (A) (MD #220570), and then plug harness (A) into the cigarette lighter.

### IMPORTANT:

Ensure the port on the combine is switched power, otherwise the In-Cab Side Draper Speed Control kit could drain the combine battery during extended shutdown periods.

### NOTE:

The cab draper control harness can also be connected at the back of the cigarette lighter using terminals T240-T241 and T250-T251, which will require some disassembly of the cab interior for access.

12. Use cable ties (MD #16661) to secure cab harness in place. Ensure a cable tie is used near the potentiometer to prevent disconnection.
13. Return the console to its original position, and reinstall the washer and hex nut (A).
14. Turn on battery disconnect. For instructions, refer to the combine manual.

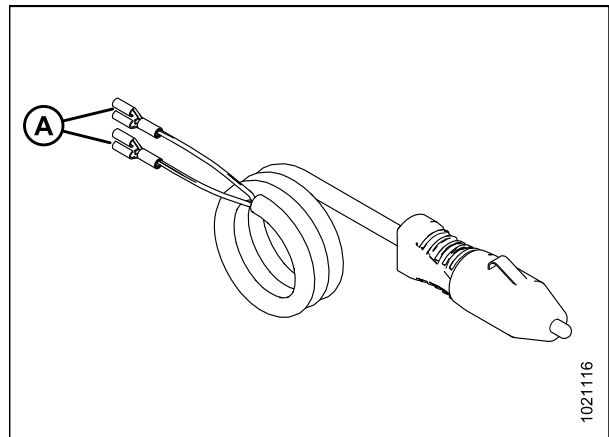

Figure 3.38: Power Adapter (MD #220570)

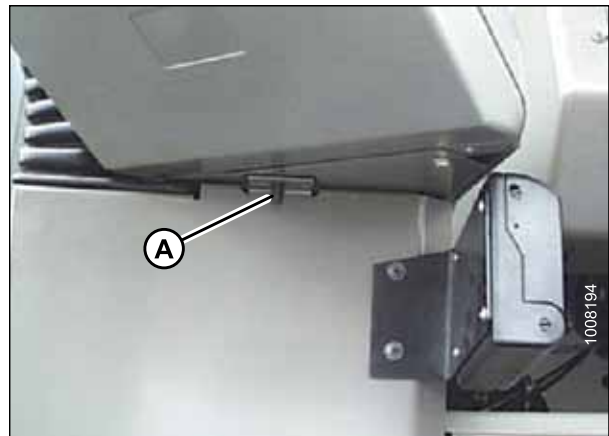

Figure 3.39: Console Monitor

## INSTALLATION INSTRUCTIONS

### 3.3.3 Installing Cab Harnesses – CLAAS 700 Series

To install cab harnesses on a CLAAS 700 Series combine, follow these steps:

1. Near the multicoupler, connect cab draper extension harness (MD #304211) to the float module as follows:
  - Connector C3A – Plug connector C3B on the valve drive harness into connector C3A.
  - Connector C5B – Plug connector C5B into connector C5A on the CLAAS completion harness.

**NOTE:**

Connector C5B does not need to be connected on model year 2018 and newer headers configured for CLAAS combines.

2. Route the cab draper extension harness (A) from the float module multicoupler, along the side of the combine feeder house, underneath the cab, and over to the right side of the combine cab. Place the harness in steel tray (B) on the underside of the cab to prevent it from being damaged.
3. Use cable ties (MD #16661) to secure the cab draper extension harness to the main harness on the left side of the feeder house and under the cab floor.

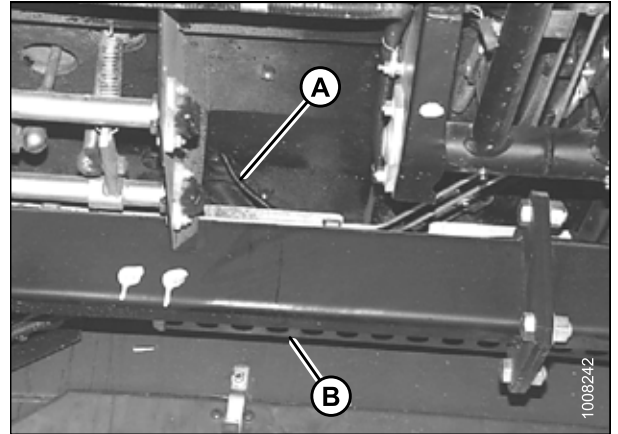

Figure 3.40: Cab Underside

4. Inside the cab, locate terminal compartment (A) on the floor, and remove the terminal compartment cover.

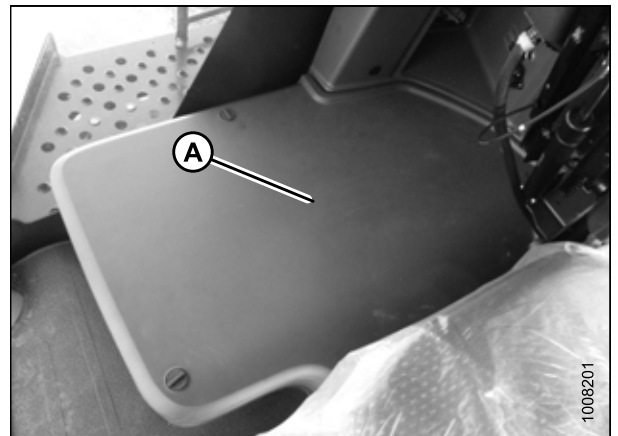

Figure 3.41: Terminal Compartment

## INSTALLATION INSTRUCTIONS

5. Make a hole (A) in one of the blank covers on the left side of the compartment. Pull the end of the cab draper extension harness into the cab through the hole.
6. Inside the cab, connect the cab draper extension harness to the cab draper control harness (MD #304210) as follows:
  - Plug C4B into C4A.
  - Plug C6B into C6A.

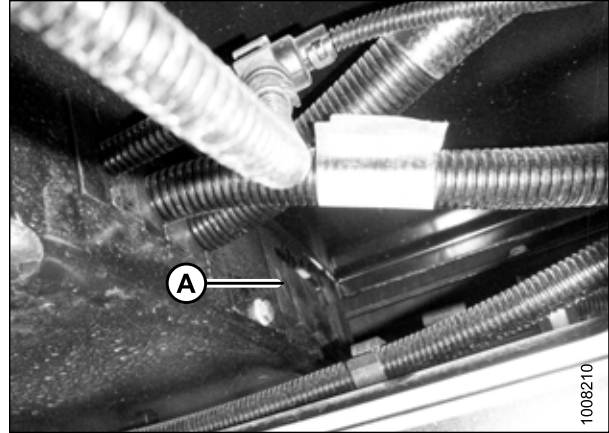

Figure 3.42: Hole for Harness

7. If the combine has a built-in tilt toggle switch on the GSL, the toggle switch on the control panel is not required. Remove toggle switch (A) from the control panel, and replace with plug (B) (MD #287784).

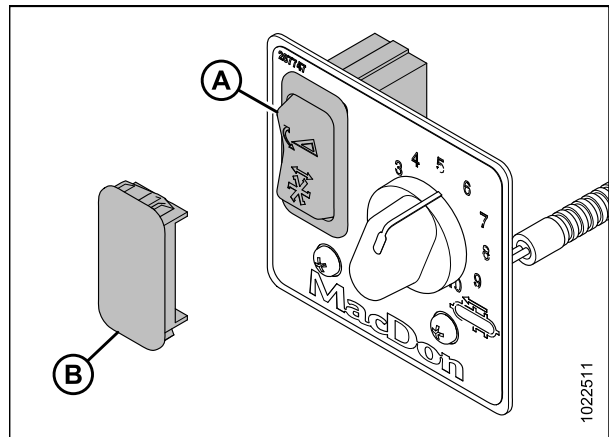

Figure 3.43: Control Panel

8. Connect connector P551 on the cab draper control harness to the control panel potentiometer (A).

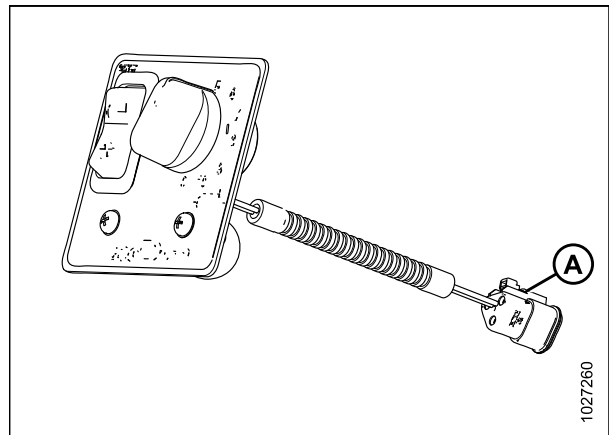

Figure 3.44: Control Panel Potentiometer

## INSTALLATION INSTRUCTIONS

9. Locate the power source for the potentiometer. The location depends on the combine model. A switched power source is either inside the terminal compartment on the cab floor or behind a removable panel beside the ignition switch. If there is no switched power available, unswitched power or a cigarette lighter adapter may be used.

Refer to the following procedures as necessary:

### ***If on-floor power source:***

10. In the terminal compartment on the floor, locate the CLAAS single-wire harness (A) and white connector (B) with one brown wire and one black wire.

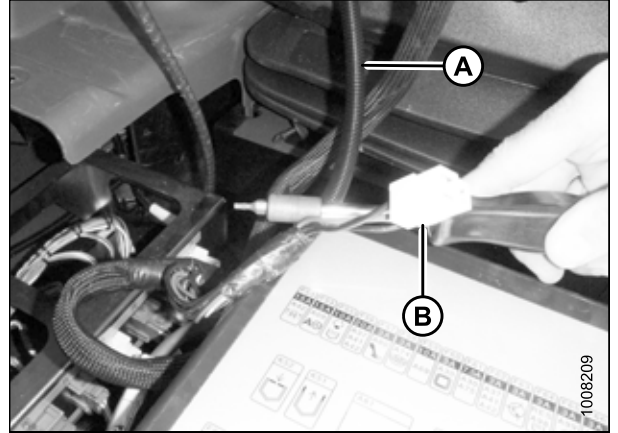

**Figure 3.45: Terminal Compartment**

11. Connect wires from the cab draper control harness (A) to the CLAAS harness (B) as follows:
  - a. Remove insulation from red (C) and black (D) connectors.
  - b. Attach red wire (C) in cab draper control harness to brown wire in CLAAS white plug (E).
  - c. Attach black wire (D) in cab draper control harness to black wire in CLAAS white plug (E).
12. Proceed to Step 21, page 34.

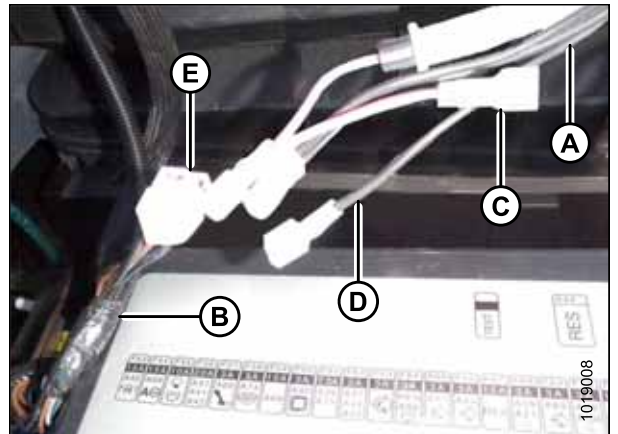

**Figure 3.46: Power Source Connection**

## INSTALLATION INSTRUCTIONS

### *If beside-ignition power source:*

13. Remove access panel (A) beside ignition to gain access to rear of cigarette lighter (B). If a white plug with two wires is available, it can be used to connect the MacDon wiring harness.



**Figure 3.47: Access Panel beside Ignition**

14. Retrieve white plug (A) on cigarette lighter wiring harness from behind cigarette lighter.
15. Route draper control harness from previously installed switch to rear right corner of cab and into panel opening. If necessary, add an extension or additional length to the MacDon wiring harness so that there is sufficient length to connect to the white plug on the CLAAS harness.



**Figure 3.48: Switched Power Harness Plug**

## INSTALLATION INSTRUCTIONS

16. Install the cab draper control harness between the cigarette lighter and lighter harness as follows:
  - a. Remove insulation from red (A) and black (B) male connectors.
  - b. Remove CLAAS harness from cigarette lighter.
  - c. Attach red wire female connector (C) on cab draper control harness to power terminal on cigarette lighter.
  - d. Attach black wire female connector (D) on cab draper control harness to negative terminal on cigarette lighter.
  - e. Attach red wire male connector (A) and black wire male connector (B) to same colored wires in the CLAAS harness connector (E) (red to red; black to black).

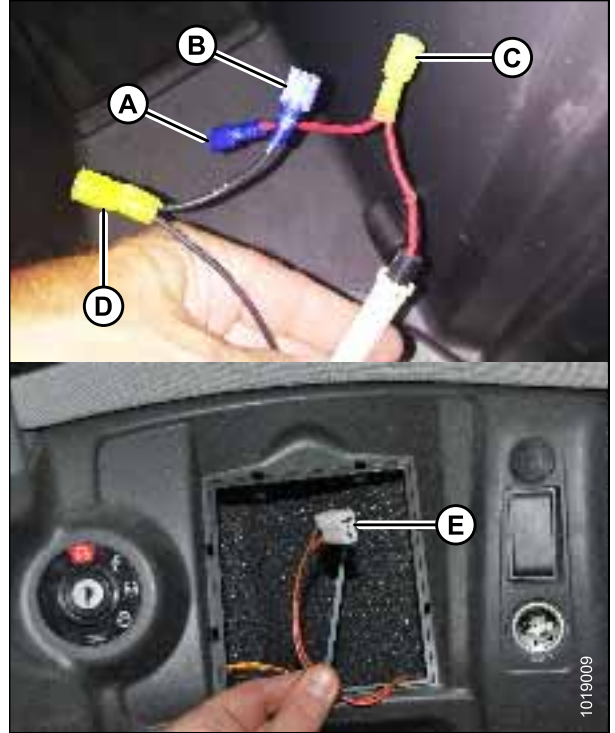

Figure 3.49: Wiring Harnesses

17. Secure MacDon harness as required with cable ties.
18. Reinstall access panel (A).
19. Proceed to Step [21, page 34](#).



Figure 3.50: Plastic Cover

## INSTALLATION INSTRUCTIONS

### ***If using an unswitched 12 V power source:***

If there are no available plugs in the switched power supply, unswitched power or a cigarette lighter adapter harness can be used.

### **IMPORTANT:**

Constant power is supplied to the header tilt side of the solenoid valve. If the circuit is left powered during extended shutdown periods, the combine battery will be drained.

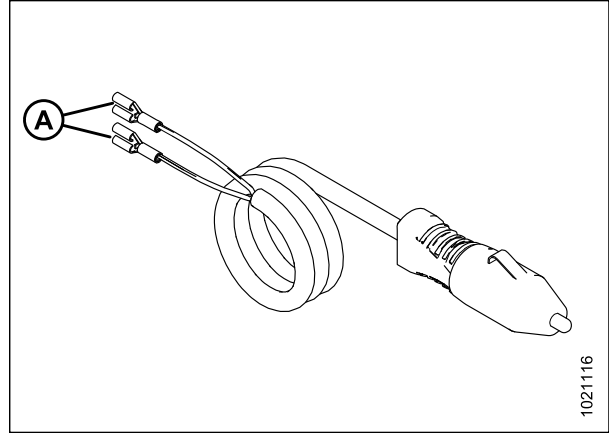

**Figure 3.51: Auxiliary Power to Quick Disc Harness (MD #220570)**

20. Connect terminals T241 and T251 on the cab draper control harness to the auxiliary power to quick disc harness (A) (MD #220570), and then plug harness (A) into the cigarette lighter.

### **IMPORTANT:**

Ensure the port on the combine is switched power, otherwise the In-Cab Side Draper Speed Control kit could drain the combine battery during extended shutdown periods.

### **NOTE:**

The cab draper control harness can also be connected at the back of the cigarette lighter using terminals T240-T241 and T250-T251, which will require some disassembly of the cab interior for access.

21. Use cable ties (MD #16661) to secure cab harness in place. Ensure a cable tie is used near the potentiometer to prevent disconnection.
22. Turn on battery disconnect. For instructions, refer to the combine manual.



## INSTALLATION INSTRUCTIONS

### 3.3.4 Connecting Cab Harnesses – Challenger, Gleaner, John Deere, and Massey Ferguson

Challenger, Gleaner, John Deere, and Massey Ferguson combines will already have cab harnesses installed because the harnesses are included in the completion packages for those combines. To connect the harnesses, follow these steps:

1. At the multicoupler, plug connector C5B on the cab draper extension harness into connector C5A (A) on the completion harness.

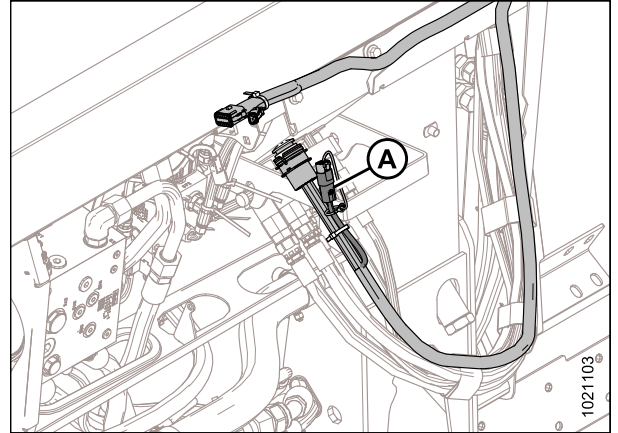

**Figure 3.52: Completion Harness – John Deere Shown**

2. Plug connector C3B (A) on the valve drive harness into connector C3A on the cab draper extension harness.

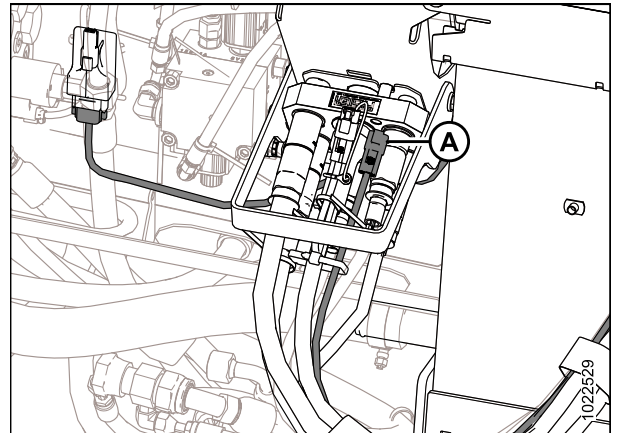

**Figure 3.53: Valve Driver Harness Connection – John Deere Shown**

## INSTALLATION INSTRUCTIONS

3. Connect connector P551 on the cab draper control harness to control panel potentiometer (A).
4. Connect terminals T242 and T243 on the cab draper control harness to terminals on the back of rocker switch (B).

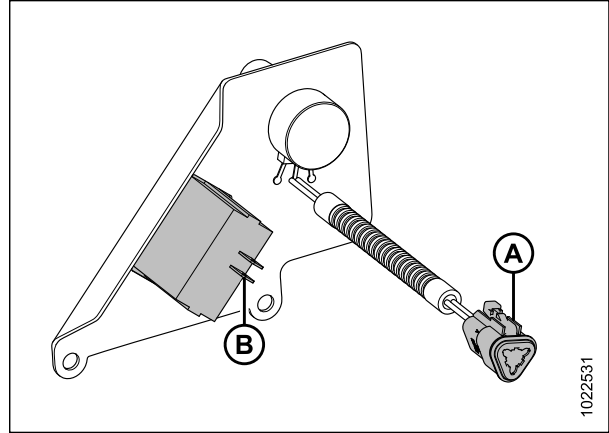

**Figure 3.54: Control Panel Connections – John Deere**

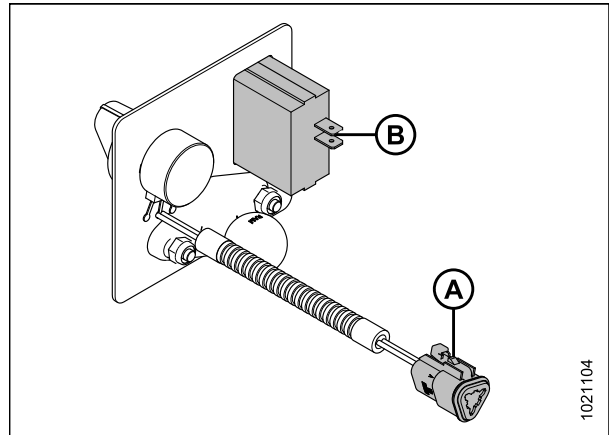

**Figure 3.55: Control Panel Connections – Challenger, Gleaner, and Massey Ferguson**

5. Connect terminals T241 and T251 on the cab draper control harness to auxiliary power to quick disc harness (A) (MD #220570), and plug harness (A) into the cigarette lighter.

### IMPORTANT:

Ensure the port on the combine is switched power, otherwise the In-Cab Side Draper Speed Control kit could drain the combine battery during extended shutdown periods.

### NOTE:

The cab harness can also be connected at the back of the cigarette lighter using terminals T240-T241 and T250-T251, which will require some disassembly of the cab interior for access.

6. Tape any unused terminals to the harness.
7. Use cable ties (MD #16661) to secure cab harness in place. Ensure a cable tie is used near the potentiometer to prevent disconnection.

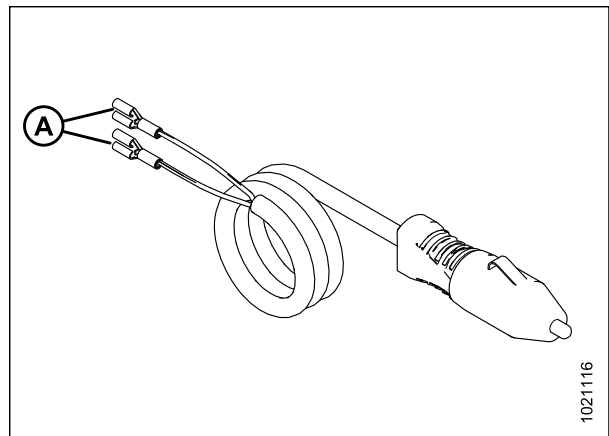

**Figure 3.56: Auxiliary Power to Quick Disc Harness (MD #220570)**

## INSTALLATION INSTRUCTIONS

8. Turn on the battery disconnect. For instructions, refer to the combine manual.



## 4 Diagnosing a Failed Side Draper Speed Control

There are two red LED indicators mounted on the valve driver on either side of the eight-pin connector. Looking at the driver with the red LEDs on the bottom, the LED on the right is the indicator used for this application. Normal operation will cause the LED to be on solid. As the output current increases, the LED's brightness will also increase. The flow control valve is normally open. As the magnetic field becomes stronger the valve will close and reduce flow to the side drapers causing them to slow down.

If the LED is flashing red once per second, there is a fault in the system. Cycle the power to clear the faults and return the system to normal operation. If it does not return to normal operation, check wiring, electrical connections, and solenoid coil operation.

Status	LED state	Condition
Off	LED is off	No supply voltage or current output is zero
Normal operation	LED is on solid, dim or bright	LED brightens or dims based on current output
Fault condition	LED blinks 1 time per second	Fault detected





**MacDon Industries Ltd.**

680 Moray Street  
Winnipeg, Manitoba  
Canada R3J 3S3  
t. (204) 885-5590 f. (204) 832-7749

**MacDon, Inc.**

10708 N. Pomona Avenue  
Kansas City, Missouri  
United States 64153-1924  
t. (816) 891-7313 f. (816) 891-7323

**MacDon Australia Pty. Ltd.**

A.C.N. 079 393 721  
P.O. Box 103 Somerton, Victoria, Australia  
Australia 3061  
t.+61 3 8301 1911 f.+61 3 8301 1912

**MacDon Brasil Agribusiness Ltda.**

Rua Grã Nicco, 113, sala 404, B. 04  
Mossunguê, Curitiba, Paraná  
CEP 81200-200 Brasil  
t. +55 (41) 2101-1713 f. +55 (41) 2101-1699

**LLC MacDon Russia Ltd.**

123317 Moscow, Russia  
10 Presnenskaya nab, Block C  
Floor 5, Office No. 534, Regus Business  
Centre  
t. +7 495 775 6971 f. +7 495 967 7600

**MacDon Europe GmbH**

Hagenauer Strasse 59  
65203 Wiesbaden  
Germany

**CUSTOMERS**

**MacDon.com**

**DEALERS**

**Portal.MacDon.com**

Trademarks of products are the marks of their  
respective manufacturers and/or distributors.

Printed in Canada