

R1 Series Rotary Disc Pull-Type

Quick Change Blade Kit for Quick Change Ready Discs B6699
(MD #257136) and B6700 (MD #257135)
Installation Instructions

214597 Revision D

Original Instruction

R1 Series Rotary Disc Pull-Type

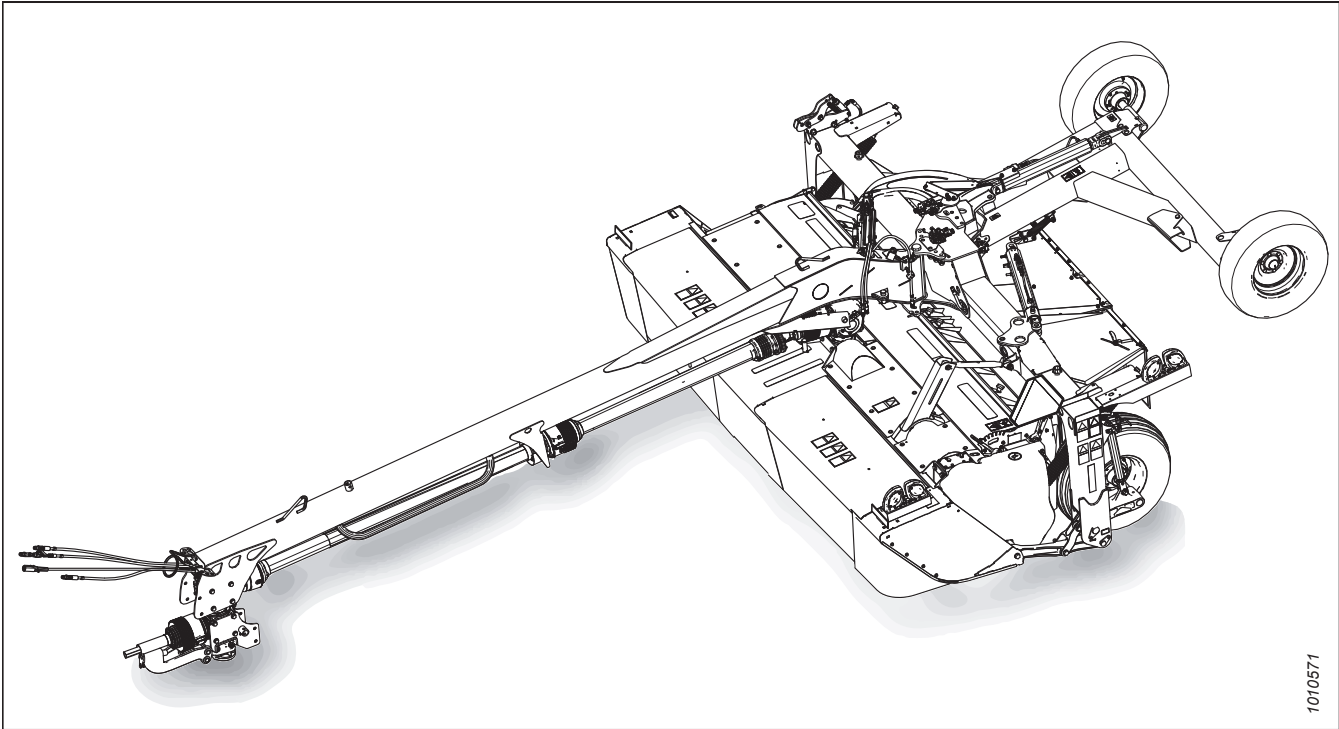

Published March 2023

© 2023 MacDon Industries, Ltd.

The information in this publication is based on the information available and in effect at the time of printing. MacDon Industries, Ltd. makes no representation or warranty of any kind, whether expressed or implied, with respect to the information in this publication. MacDon Industries, Ltd. reserves the right to make changes at any time without notice.

Introduction

This document explains how to install the Quick Change Blade kit on R1 Series headers equipped with quick change blade discs.

A list of parts included in the kit is provided in Chapter 2 *Parts List, page 4*.

NOTE:

This kit is compatible with rotary disc pull-types equipped with quick change ready discs (B). Quick change ready discs are identified by the larger cut-out allowing access for the quick change blade tool.

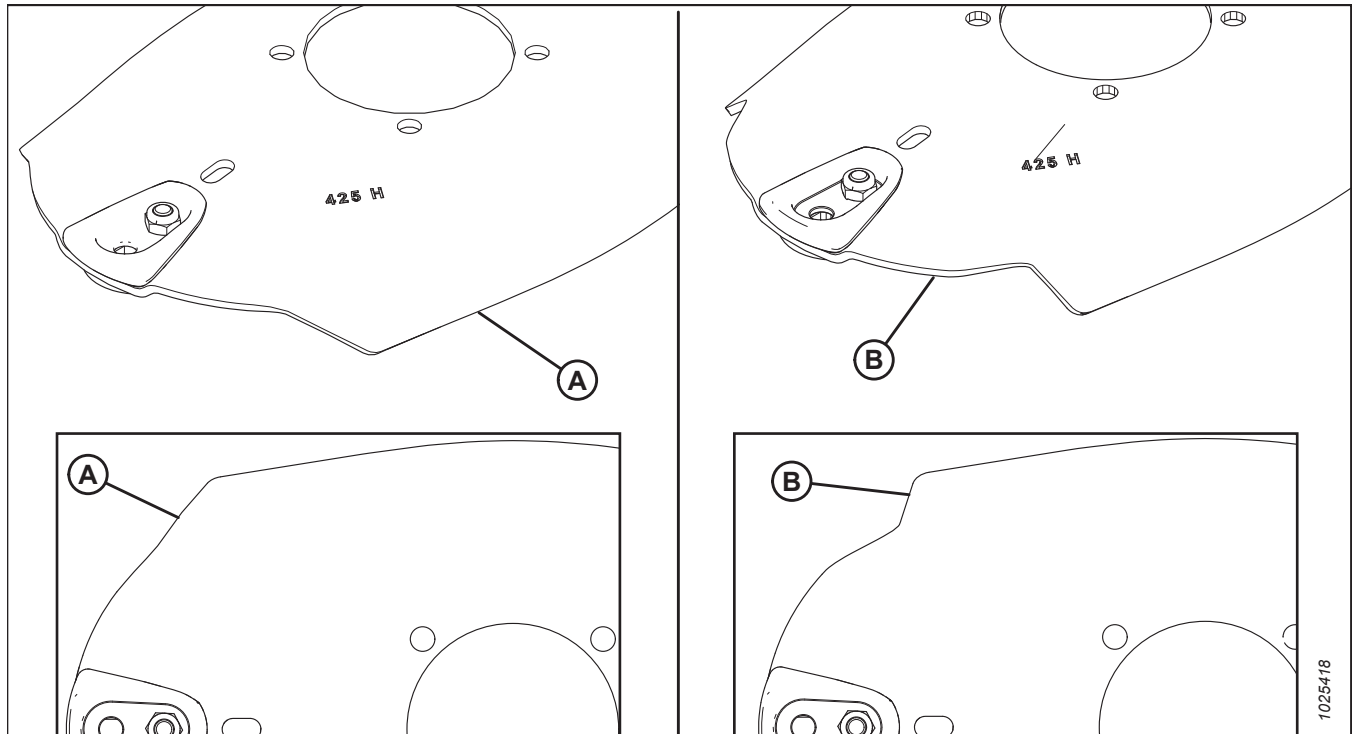

Figure 1: Standard Discs and Quick Change Blade Ready Discs

A - Standard Discs

B - Quick Change Blade Ready Discs

Installation Time

Installation time for this kit is approximately 3.5 hours depending if you have an 8- or 10-disc cutterbar.

Conventions

The following conventions are used in this document:

- Right and left are determined from the operator's position. The front of the rotary disc pull-types is the side that faces the crop.
- Unless otherwise noted, use the standard torque values provided in the rotary disc pull-types operator's manual and technical manual.

NOTE:

Keep your MacDon publications up-to-date. The most current version of this instruction can be downloaded from our Dealer-only site (<https://portal.macdon.com>) (login required).

NOTE:

This document is available in English only.

Summary of Changes

At MacDon, we're continuously making improvements, and occasionally these improvements affect product documentation. The following list provides an account of major changes from the previous version of this document.

Section	Summary of Change	Internal Use Only
Front cover and the introduction	Added B6699 and B6700.	Technical Publications
<i>2 Parts List, page 4</i>	Added the following: <ul style="list-style-type: none"> • MD #183866 • MD #135799 • MD #135852 	ECN 64003 ECN 64085
<i>3 Installation Instructions, page 7</i>	Moved the safety steps from <i>3.2 Installing Quick Change Blade System on Discs, page 16</i> and <i>3.3 Installing Quick Change Blades, page 20</i> to <i>3 Installation Instructions, page 7</i> to reduce repetitive steps.	Technical Publications
<i>3.4.1 Installing Tool Storage Bracket – Steel and Polyurethane Conditioners, page 23</i>	Added topic.	ECN 64003
<i>3.4.2 Installing Tool Storage Bracket – Finger Conditioners, page 25</i>	Added topic.	ECN 64003
<i>3.5 Storing Quick Change Blade Tool, page 26</i>	Enlarged illustration for clarity. Revised associated steps to accommodate the different configurations (conditioners) of rotary disc pull-types.	Technical Publications

TABLE OF CONTENTS

Introduction i

Summary of Changes..... ii

Chapter 1: Safety 1

 1.1 Signal Words 1

 1.2 General Safety 2

Chapter 2: Parts List..... 4

Chapter 3: Installation Instructions 7

 3.1 Installing Quick Change Blade System on Driven Drums..... 7

 3.2 Installing Quick Change Blade System on Discs..... 16

 3.3 Installing Quick Change Blades 20

 3.4 Installing Quick Change Blade Tool Storage Bracket 22

 3.4.1 Installing Tool Storage Bracket – Steel and Polyurethane Conditioners 23

 3.4.2 Installing Tool Storage Bracket – Finger Conditioners..... 25

 3.5 Storing Quick Change Blade Tool 26

Chapter 1: Safety

Understanding and following safety procedures consistently will help to ensure the safety of machine operators and bystanders.

1.1 Signal Words

Three signal words, **DANGER**, **WARNING**, and **CAUTION**, are used to alert you to hazardous situations. Two signal words, **IMPORTANT** and **NOTE**, identify non-safety related information.

Signal words are selected using the following guidelines:

DANGER

Indicates an imminently hazardous situation that, if it is not prevented, will result in death or serious injury.

WARNING

Indicates a potentially hazardous situation that, if it is not prevented, could result in death or serious injury. It may also be used to alert you to unsafe practices.

CAUTION

Indicates a potentially hazardous situation that, if it is not prevented, may result in minor or moderate injury. It may also be used to alert you to unsafe practices.

IMPORTANT:

Indicates a situation that, if not prevented, could result in a malfunction or damage to the machine.

NOTE:

Provides additional information or advice.

1.2 General Safety

Operating, servicing, and assembling machinery presents several safety risks. These risks can be reduced or eliminated by following the relevant safety procedures and wearing the appropriate personal protective equipment.

CAUTION

The following general farm safety precautions should be part of your operating procedure for all types of machinery.

Wear all protective clothing and personal safety devices that could be necessary for the job at hand. Do **NOT** take chances. You may need the following:

- Hard hat
- Protective footwear with slip-resistant soles
- Protective glasses or goggles
- Heavy gloves
- Wet weather gear
- Respirator or filter mask

In addition, take the following precautions:

- Be aware that exposure to loud noises can cause hearing impairment. Wear suitable hearing protection devices such as earmuffs or earplugs to help protect against loud noises.



Figure 1.1: Safety Equipment



Figure 1.2: Safety Equipment

- Provide a first aid kit in case of emergencies.
- Keep a properly maintained fire extinguisher on the machine. Familiarize yourself with its use.
- Keep young children away from machinery at all times.
- Be aware that accidents often happen when Operators are fatigued or in a hurry. Take time to consider the safest way to accomplish a task. **NEVER** ignore the signs of fatigue.

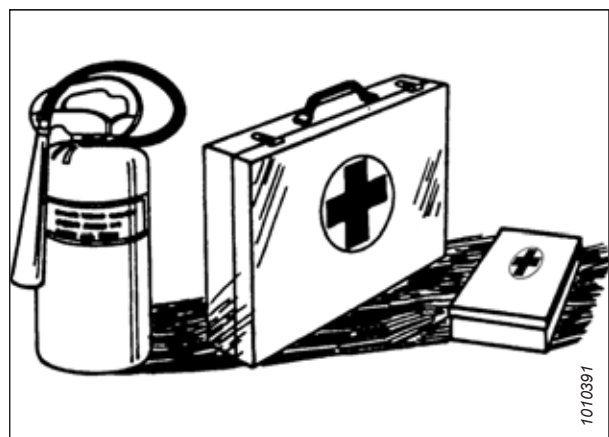

Figure 1.3: Safety Equipment

SAFETY

- Wear close-fitting clothing and cover long hair. **NEVER** wear dangling items such as hoodies, scarves, or bracelets.
- Keep all shields in place. **NEVER** alter or remove safety equipment. Ensure that the driveline guards can rotate independently of their shaft, and that they can telescope freely.
- Use only service and repair parts made or approved by the equipment manufacturer. Parts from other manufacturers may not meet the correct strength, design, or safety requirements.



Figure 1.4: Safety around Equipment

- Keep hands, feet, clothing, and hair away from moving parts. **NEVER** attempt to clear obstructions or objects from a machine while the engine is running.
- Do **NOT** modify the machine. Unauthorized modifications may impair the functionality and/or safety of the machine. It may also shorten the machine's service life.
- To avoid injury or death from the unexpected startup of the machine, **ALWAYS** stop the engine and remove the key from the ignition before leaving the operator's seat for any reason.

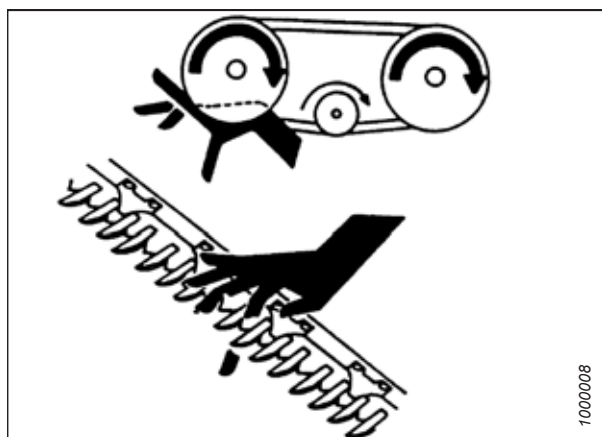

Figure 1.5: Safety around Equipment

- Keep the machine service area clean and dry. Wet and/or oily floors are slippery. Wet spots can be dangerous when working with electrical equipment. Ensure that all electrical outlets and tools are properly grounded.
- Keep the work area well-lit.
- Keep machinery clean. Straw and chaff on a hot engine are fire hazards. Do **NOT** allow oil or grease to accumulate on service platforms, ladders, or controls. Clean machines before they are stored.
- **NEVER** use gasoline, naphtha, or any volatile material for cleaning purposes. These materials may be toxic and/or flammable.
- When storing machinery, cover any sharp or extending components to prevent injury from accidental contact.



Figure 1.6: Safety around Equipment

Chapter 2: Parts List

A parts list is provided in this instruction so that you can confirm that you have received all required parts before you begin installation.

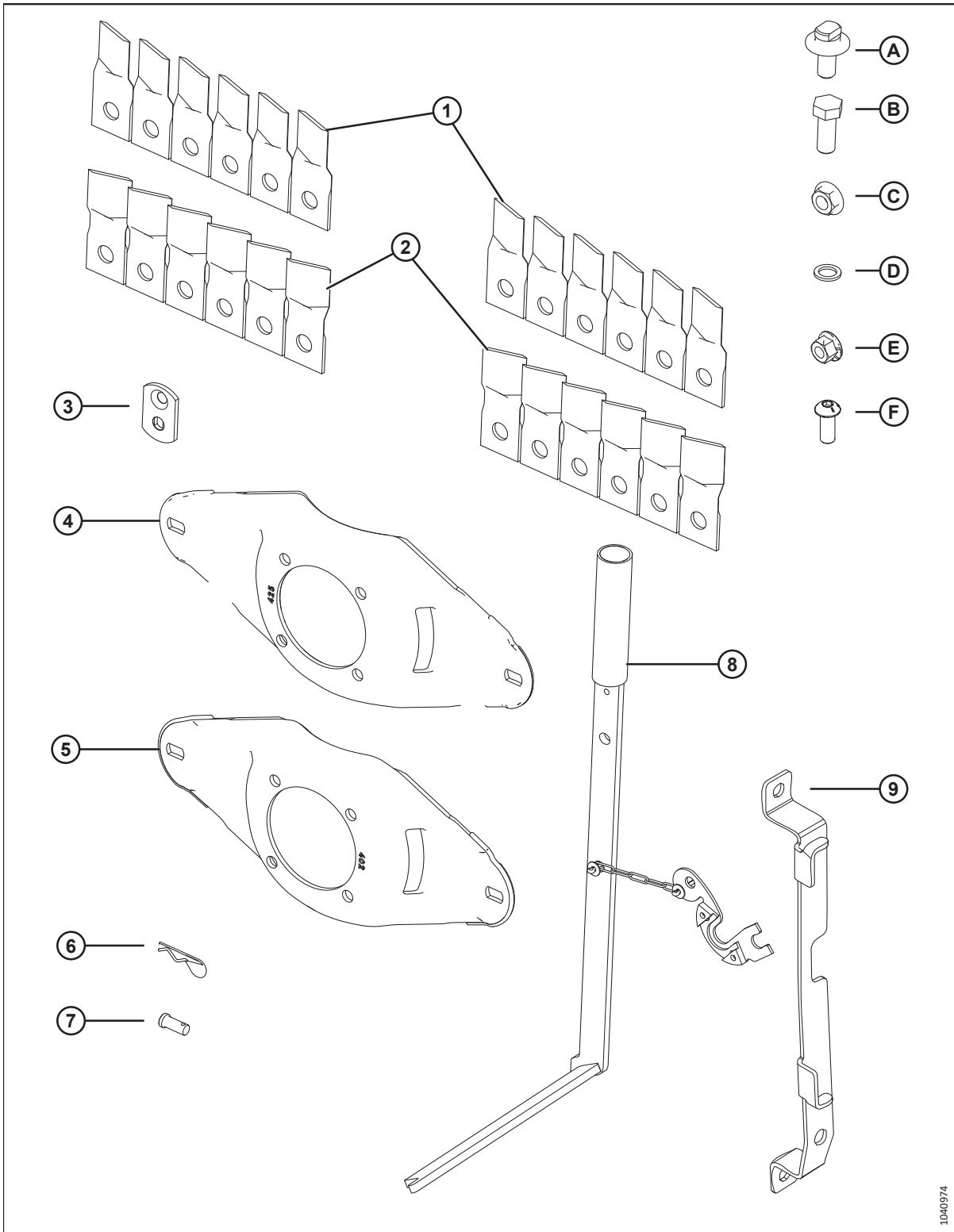

PARTS LIST

Ref	Part Number	Description	Qty	
			10 Disc	8 Disc
1	259200	BLADE – CCW 18° BEVEL DOWN QTY 6	2	2
2	259199	BLADE – CW 18° BEVEL DOWN QTY 6	2	2
3	246301	PLATE – BLADE, 5 MM	20	16
4	281364	PLATE – QUICK CHANGE, 425 MM	8	6
5	281365	PLATE – QUICK CHANGE, 402 MM (OUTSIDE DRUMS)	2	2
6	15380	PIN – HAIR	1	1
7	281931	PIN – CLEVIS 7/16 X 1	1	1
8	259112	TOOL – BLADE CHANGE ASSEMBLY	1	1
9	183866	BRACKET – QCB MOUNT	1	1
A	281363	BOLT – BLADE, QUICK CHANGE M12 X 1.75	20	16
B	30630	BOLT – HEX HD TFL M12 X 1.75 X 30-8.8-A3L	40	32
C	246300	NUT – BLADE	20	16
D	246952	WASHER – M12 LOCKING DISC	40	32
E	135799	NUT – HEX FLG CTR LOC M10 X 1.5-10	2	2
F	135852	SCR – HEX SOC BTN HD M10 X 1.5 X 25-10.9-AA1J	2	2

Chapter 3: Installation Instructions

To install the Quick Change Blade system, perform the following procedures in order.

DANGER

To avoid bodily injury or death from unexpected start-up or fall of a raised machine, always stop engine and remove key before leaving the operator's seat, and always engage safety props or close lock-out valves before going under the machine for any reason.

WARNING

Disc blades have two sharp cutting edges that can cause serious injury. Exercise caution and wear gloves when working with blades.

1. Raise the rotary disc pull-type fully.
2. Shut down the engine, and remove the key from the ignition.
3. Close the lift cylinder lock-out valves. For instructions, refer to the rotary disc pull-type operator's or technical manual.

3.1 Installing Quick Change Blade System on Driven Drums

NOTE:

The illustrations show the left side drum and driveline—the right side drum and driveline are similar.

NOTE:

There are two sizes of spring plates used with the Quick Change Blade system. The outboard drums use the 402 mm discs (MD #281365), and the inboard drums use the larger 425 mm discs (MD #281364).

1. Open the cutterbar doors. Refer to the operator's manual for instructions.

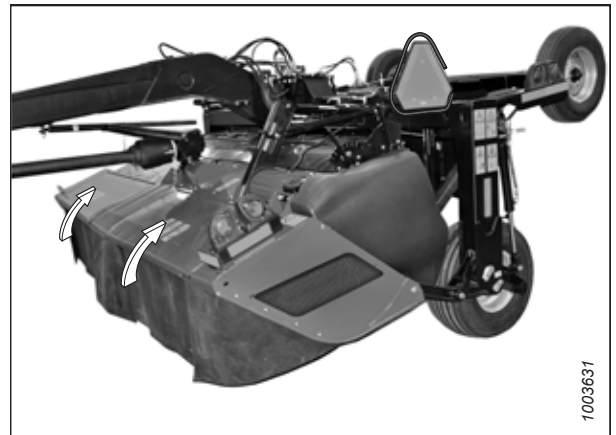

Figure 3.1: R113 Rotary Disc Pull-Type

INSTALLATION INSTRUCTIONS

2. Remove four M10 hex flange head bolts (A) and remove vertical driveshield (B).

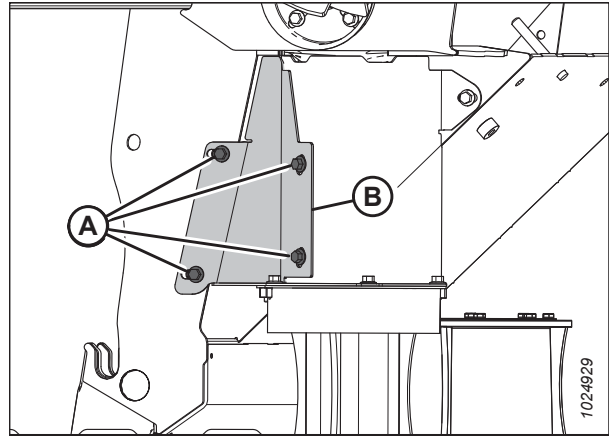

Figure 3.2: Driveline Shield

3. Remove two M10 hex flange head bolts (B) and cover plate (A).

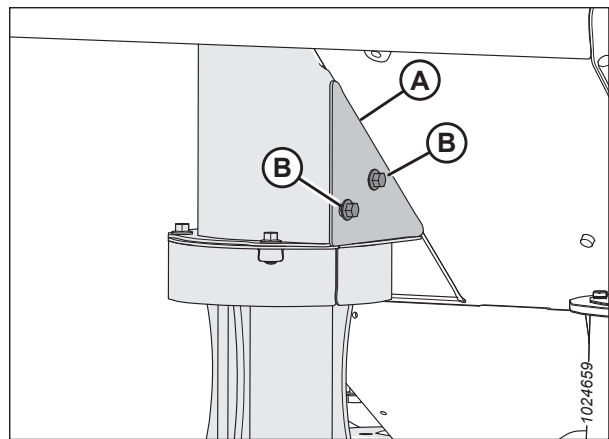

Figure 3.3: Driveline Shield

4. Remove four M10 hex flange head bolts (A), top plate (B), and drum top (C).

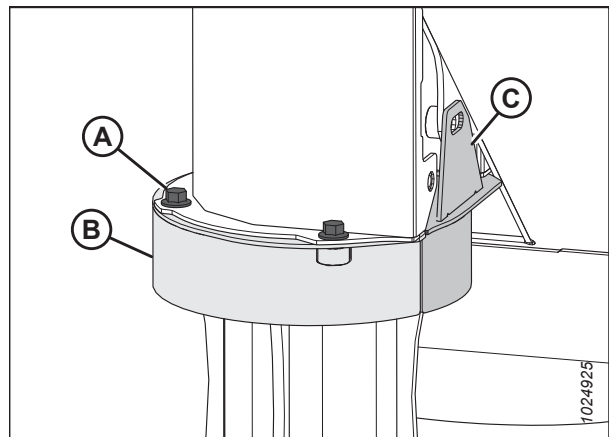

Figure 3.4: Driveline Shield

INSTALLATION INSTRUCTIONS

5. Remove one 20 mm M10 hex flange head bolt (B), two 16 mm M10 hex flange head bolts (C), and vertical shield (A).

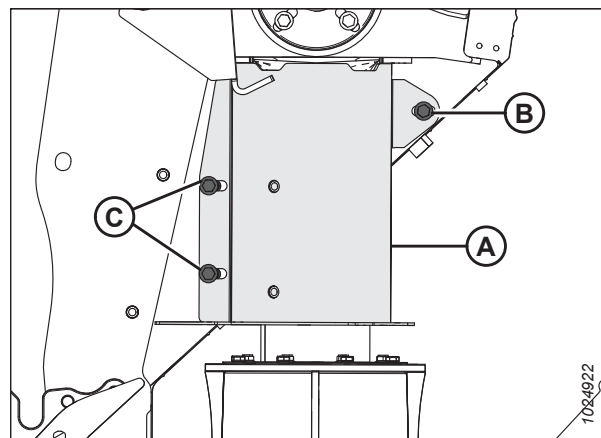

Figure 3.5: Driveline Shield

6. Remove eight M8 hex flange head bolts (A) and two drum shields (B).

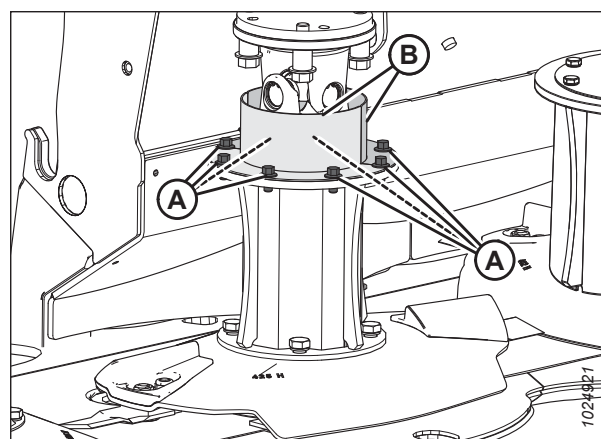

Figure 3.6: Driveline Shield

7. Remove four M12 hex flange head bolts and spacers (A) securing driveline assembly (B) to hub drive (C).

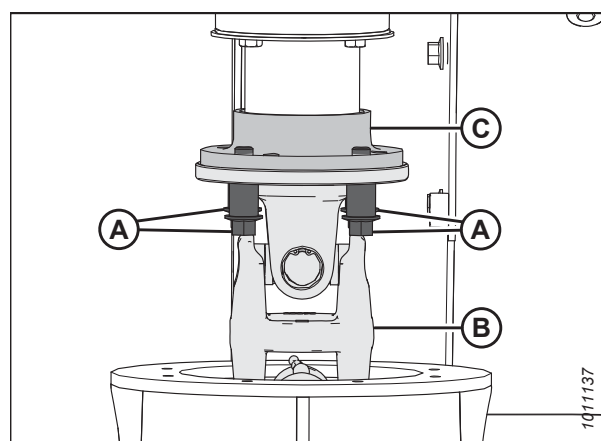

Figure 3.7: Hub Drive to Driveline Connection

INSTALLATION INSTRUCTIONS

- Slide driveline (A) downwards, tilt it to the side, and pull the driveline up and out of drum.

NOTE:

For clarity, the illustration shows a cutaway view of the drum and the tube shield.

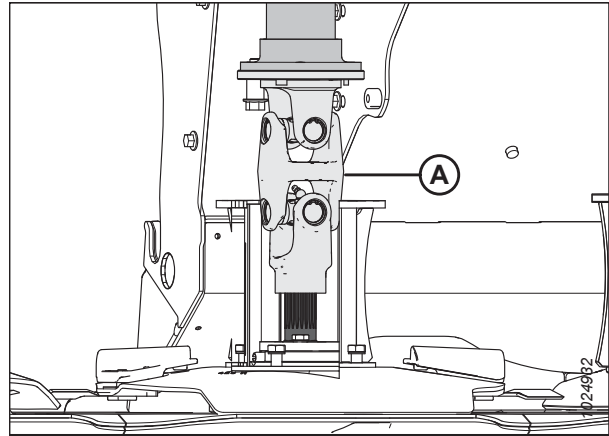

Figure 3.8: Hub Drive to Driveline Connection

- Remove four M12 bolts and washers (A) holding the drum disc in place.
- Remove drum disc assembly (B).

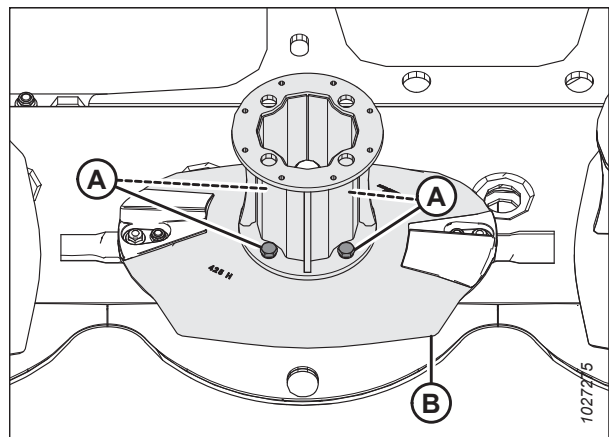

Figure 3.9: Driven Drum

- Remove and discard spacer (A).

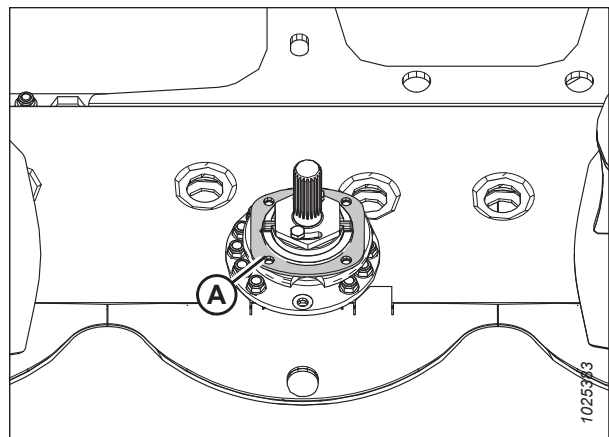

Figure 3.10: Disc Drum Spacer

INSTALLATION INSTRUCTIONS

12. Remove accelerator bolt (A), nut (B), and spacer (C) from the drum disc assembly. Discard spacer (C). Retain accelerator (D) and the hardware for reassembly.

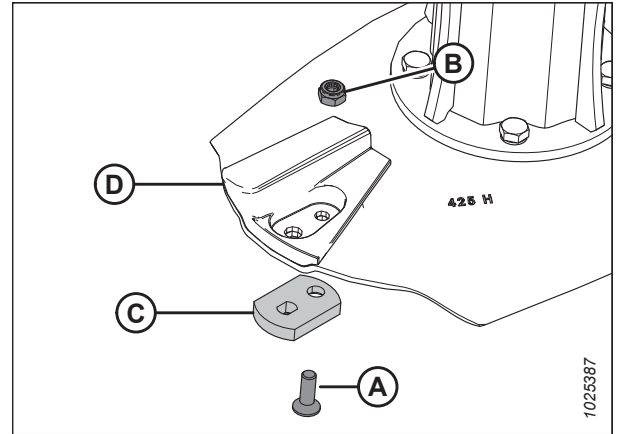

Figure 3.11: Accelerator Removal

13. Install new plate (A) (MD #246301) and retained accelerator (B) using retained accelerator nut and bolt (C). Torque nut (C) to 58 Nm (43 lbf-ft).
14. Install blade bolt (D) (MD #281363) and blade nut (E) (MD #246300) supplied with the kit. Torque the nut to 118–132 Nm (87–97 lbf-ft).

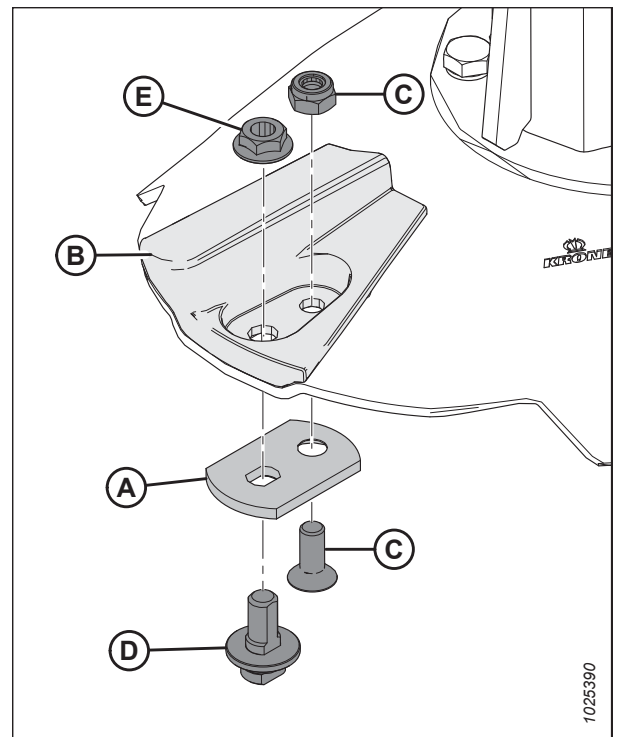

Figure 3.12: Quick Change Blade Bolt

INSTALLATION INSTRUCTIONS

15. Install new quick change plate (A) (MD #281364) over spindle (B).

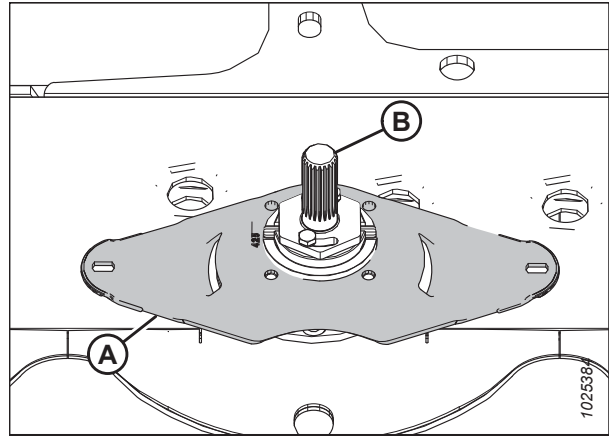

Figure 3.13: Quick Change Plate on Spindle

16. Using four new M12 disc cover bolts (A) (MD #30630) and locking disc washer (B) (MD #246952), attach drum assembly (C) to quick change plate (D) and spindle (E). Torque the bolts to 85 Nm (63 lbf-ft).

NOTE:

Check that the new disc cover bolts (A) are used. They are longer than the discarded disc cover bolts.

NOTE:

Check that blade bolt (F) is aligned with the hole in quick change plate (D).

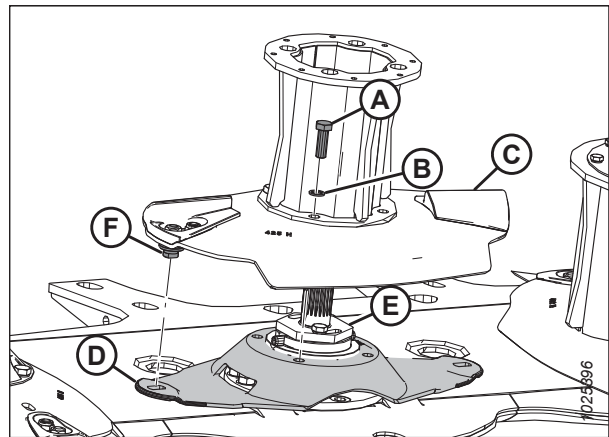

Figure 3.14: Attaching Driven Drum with Blade

17. Lubricate spindle splines (A). For lubricant specifications, refer to the header operator's manual or technical manual.

NOTE:

For clarity, the illustration shows a cutaway view of the drum and tube shield.

18. Insert driveline (B) at an angle and guide it past hub drive (C) and drum (D).
19. Insert splined spindle end (A) into the splined bore of driveline (B).

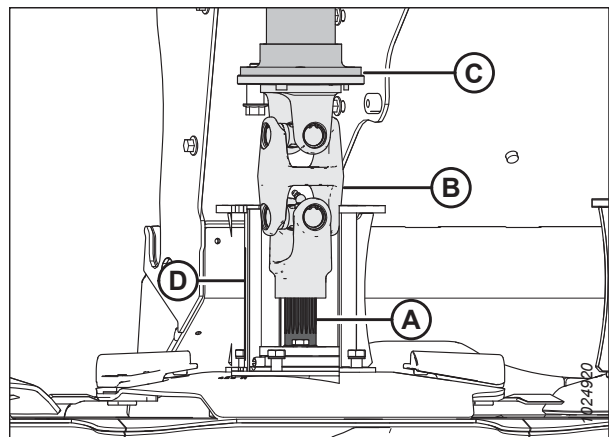

Figure 3.15: Hub Drive to Driveline Connection

INSTALLATION INSTRUCTIONS

20. Place a bead of medium-strength threadlocker (Loctite® 243 or equivalent) around the threads of four M12 hex flange head bolts (A). Use the bolts and spacers to secure driveline assembly (B) to hub drive (C). Torque the bolts to 102 Nm (75 lbf-ft).

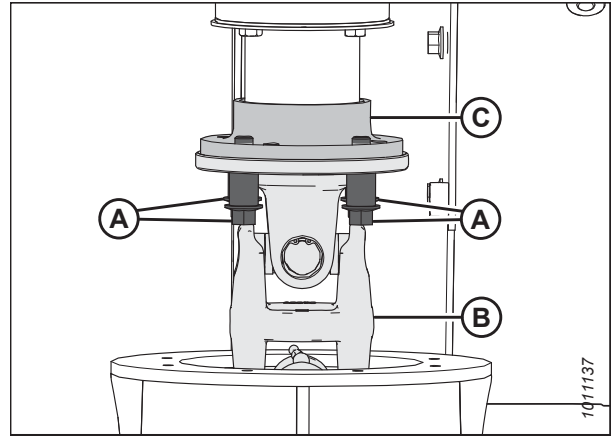

Figure 3.16: Hub Drive to Driveline Connection

21. Position two drum shields (B) as shown. Apply a bead of medium-strength threadlocker (Loctite® 243 or equivalent) around the threads of eight M8 hex flange head bolts (A). Use the bolts to secure the drum shields. Torque the hardware to 27 Nm (239 lbf-in).

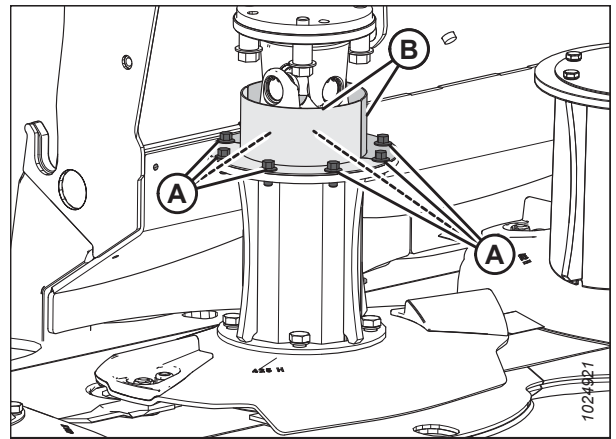

Figure 3.17: Driven Drum

22. Position vertical shield (A) as shown. Apply a bead of medium-strength threadlocker (Loctite® 243 or equivalent) around the threads of one M10 x 20 mm hex flange head bolt (B) and two M10 x 16 mm hex flange head bolts (C). Use bolts (B) and (C) to secure the vertical shield. Torque the hardware to 61 Nm (45 lbf-ft).

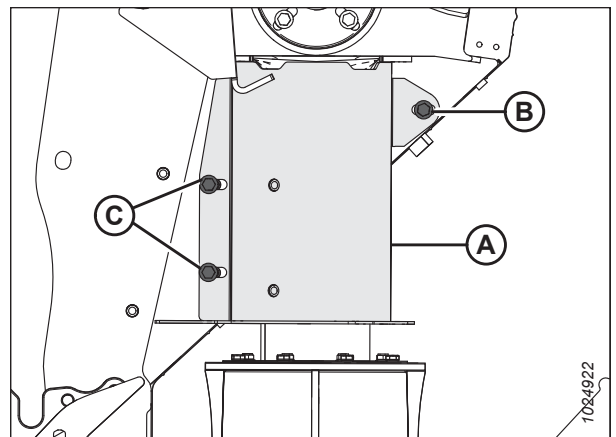

Figure 3.18: Driveline Shield

INSTALLATION INSTRUCTIONS

23. Position top plate (B) and drum top (C) onto the drum as shown. Apply a bead of medium-strength threadlocker (Loctite® 243 or equivalent) around the threads of four M10 hex flange head bolts (A). Use the bolts to secure the top plate and the drum top. Torque the hardware to 61 Nm (45 lbf-ft).

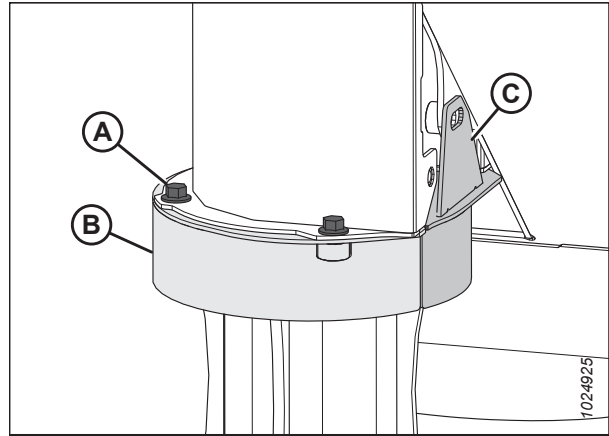

Figure 3.19: Driveline Shield

24. Apply a bead of medium-strength threadlocker (Loctite® 243 or equivalent) around the threads of M10 hex flange head bolt (B). Install bolt (B) through cover plate (A) and top plate (C). Torque the hardware to 61 Nm (45 lbf-ft).
25. Apply a bead of medium-strength threadlocker (Loctite® 243 or equivalent) around the threads of M10 hex flange head bolt (D). Install bolt (D) through cover plate (A) and vertical shield (E). Torque the hardware to 61 Nm (45 lbf-ft).
26. Tighten bolts (B) and (D).

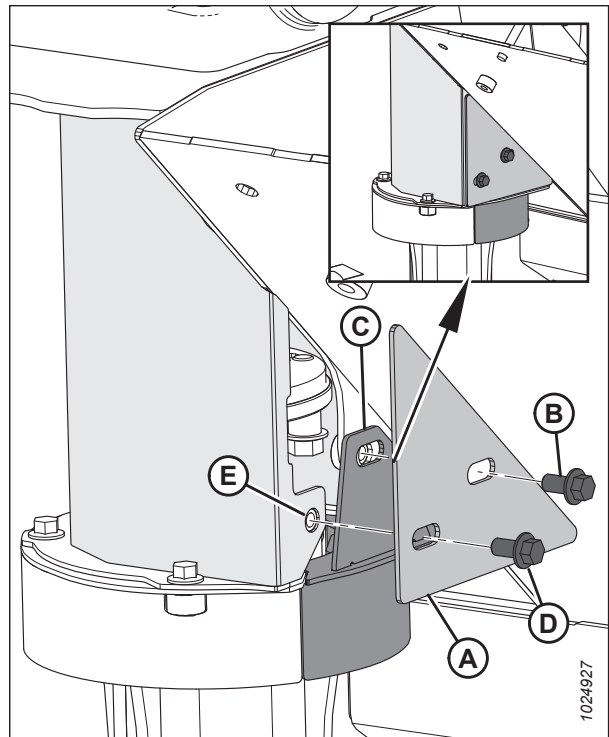

Figure 3.20: Driveline Shield

INSTALLATION INSTRUCTIONS

27. Position vertical driveshield (B) as shown at right. Apply a bead of medium-strength threadlocker (Loctite® 243 or equivalent) around the threads of four M10 hex flange head bolts (A). Use bolts (A) to secure the vertical driveshield. Torque the hardware to 61 Nm (45 lbf-ft).

WARNING

Ensure that the cutterbar is completely clear of foreign objects. Foreign objects can be ejected with considerable force when the machine is started, which can result in serious injury or cause damage to the machine.

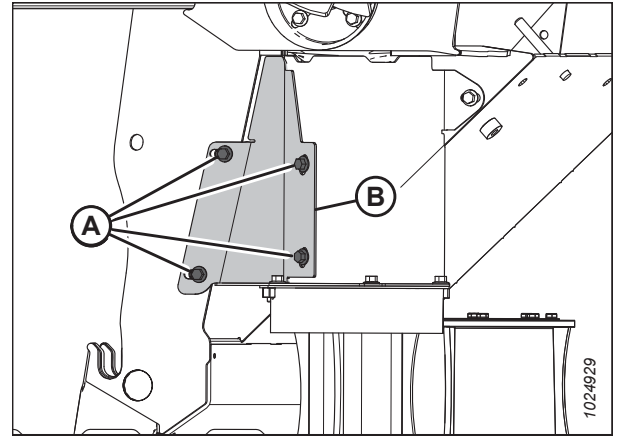

Figure 3.21: Driveline Shield

3.2 Installing Quick Change Blade System on Discs

Cutterbar discs are interchangeable and can be moved to a spindle that rotates in the opposite direction as long as it is in usable condition and the blades are oriented to cut in the correct direction.

NOTE:

There are two sizes of spring plates used with the Quick Change Blade system. The outboard drums use the 402 mm discs (MD #281365), and the inboard drum use the larger 425 mm discs (MD #281364).

1. Open the cutterbar doors. Refer to your operator’s manual for instructions.



Figure 3.22: Rotary Disc Pull-Type

2. Place a pin (or equivalent) in front hole (B) of the rock guard to prevent the discs from rotating while you are loosening the bolts.
3. Remove four M12 bolts and washers (A).

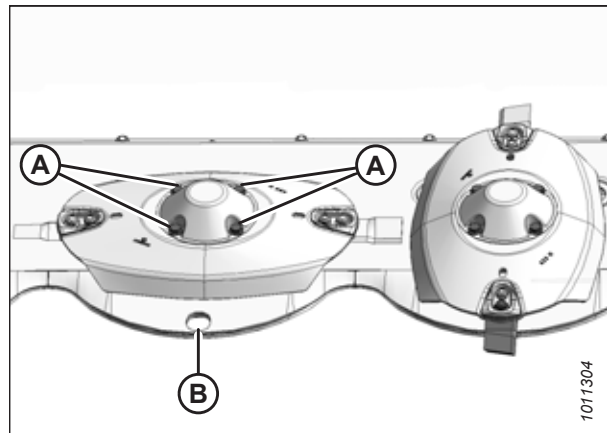

Figure 3.23: Cutterbar Disc Bolts

4. Remove cutterbar disc cap (A).
5. Remove cutterbar disc (B).

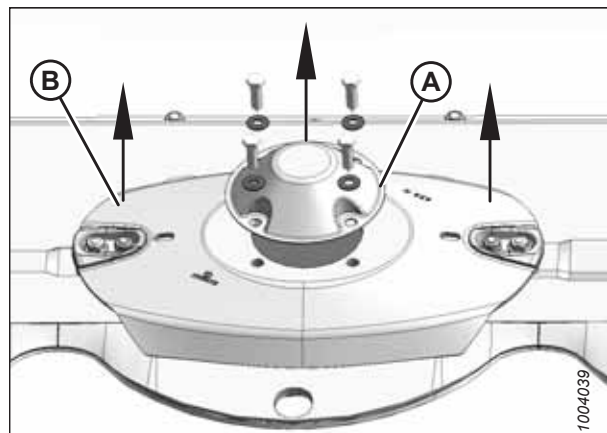

Figure 3.24: Cutterbar Disc and Cap

INSTALLATION INSTRUCTIONS

6. Remove and discard spacer (A).

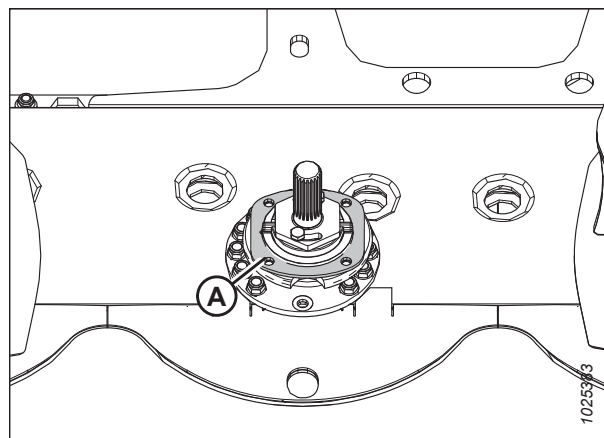

Figure 3.25: Disc Drum Spacer

7. Remove bolt (A), nut (B), disc guard (C), and 10 mm spacer (D) from the disc assembly. Retain the hardware and disc guard for reassembly. Discard the spacer.

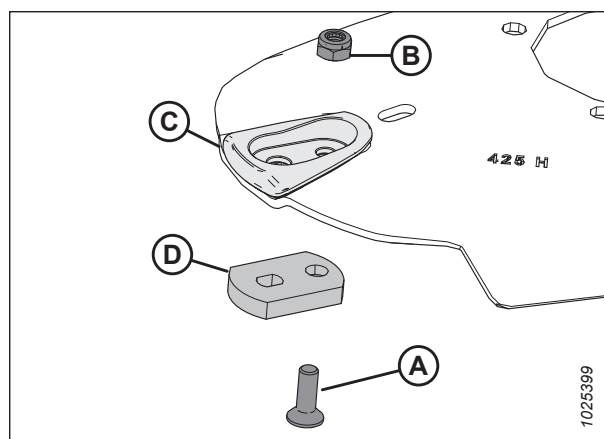

Figure 3.26: Blade Removal

INSTALLATION INSTRUCTIONS

8. Install new plate (A) (MD #246301) and retained disc guard (B) using retained accelerator nut and bolt (C). Torque nut (C) to 58 Nm (43 lbf·ft).
9. Install blade bolt (D) (MD #281363) and blade nut (E) (MD #246300) supplied with the kit. Torque the nut to 118–132 Nm (87–97 lbf·ft).

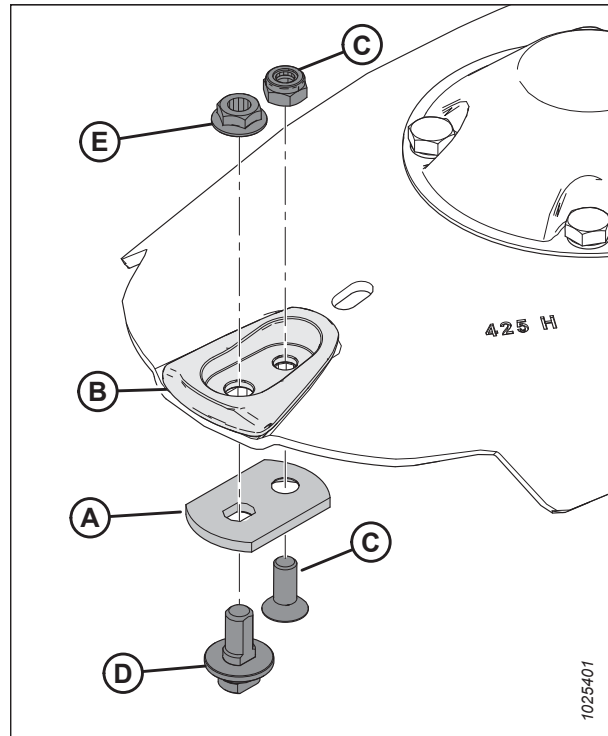

Figure 3.27: Quick Change Blade Bolt

10. Place quick change plate (A) (MD #281364) over cutterbar spindle (B).

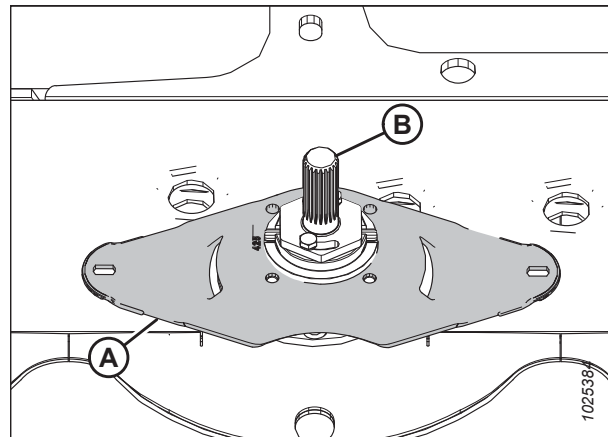

Figure 3.28: Quick Change Plate

INSTALLATION INSTRUCTIONS

- Using four new M12 disc cover bolts (A) (MD #30630) and locking disc washer (B) (MD #246952), attach disc and disc cap (C) to quick change plate (D) and spindle (E). Torque the bolts to 85 Nm (63 lbf·ft).

NOTE:

Check that the new disc cover bolts (A) are used. They are longer than the discarded disc cover bolts.

NOTE:

Check that blade bolt (F) is aligned with the hole in quick change plate (D).

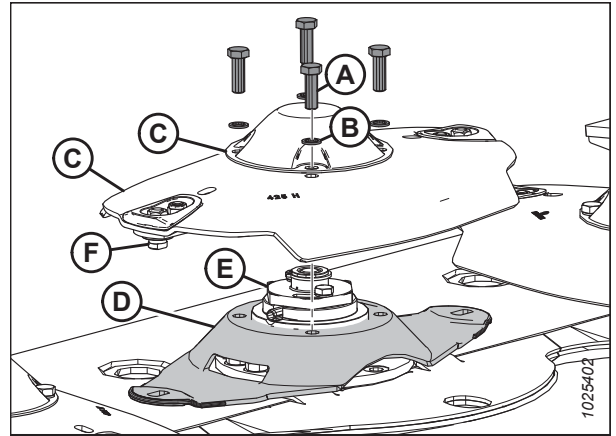

Figure 3.29: Attaching Disc to Spindle

3.3 Installing Quick Change Blades

This kit contains clockwise and counterclockwise 18° bevel down quick change disc blades. The disc blades have cutting edges on both sides so the blades can be turned over and reused. The twist in each blade determines the cutting direction.

NOTE:

If you are unsure which direction the spindles rotate, refer to the rotary disc pull-type operator’s manual or technical manual.

1. Retrieve the change tool (MD #259112) from the shipping location.
2. Slide the flat bar on quick blade change tool (A) between disc (B) and quick change plate (C) from the side.

NOTE:

If required, remove any material that has collected between quick change plate (C) and the rock guard.

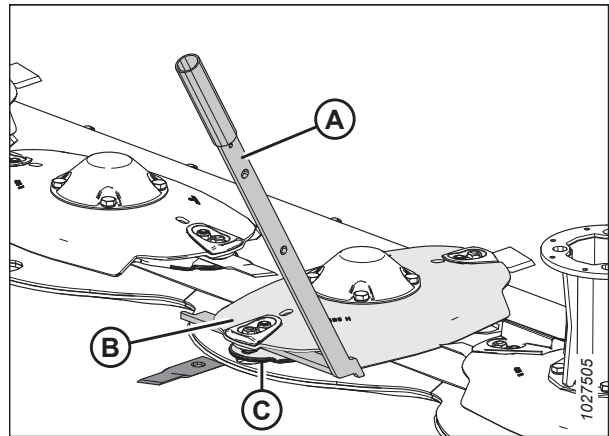

Figure 3.30: Blade Change Tool

IMPORTANT:

Check that the flat bar on blade change tool (A) is touching on both sides of the disc at location (B).

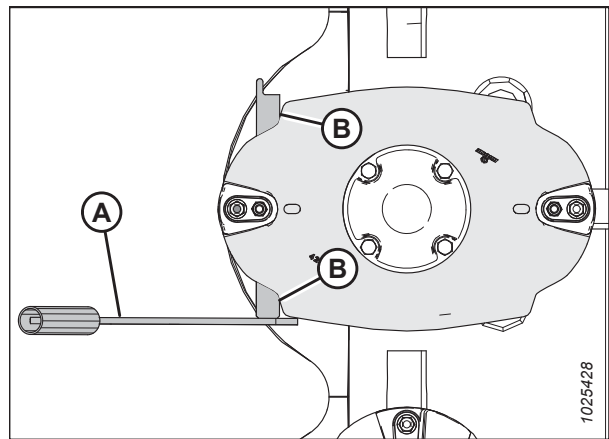

Figure 3.31: Correct Positioning of Blade Change Tool

INSTALLATION INSTRUCTIONS

3. Pull down on blade change tool (A), separate disc (B) from quick change plate (C), and remove old blade (D) from blade bolt (E). Push blade change tool (A) upward to return quick change plate (C) to the closed position.
4. Pull down on blade change tool (A) and separate disc (B) from quick change plate (C). Insert new blade (D) on blade bolt (E).
5. Push blade change tool (A) upward, enclosing new blade (D) in the disc assembly.

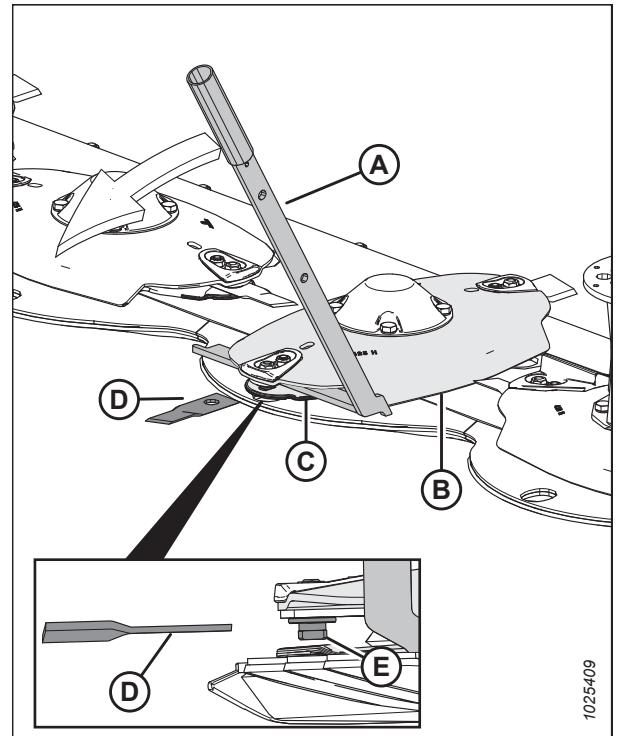

Figure 3.32: Installing Quick Change Blade

3.4 Installing Quick Change Blade Tool Storage Bracket

DANGER

To prevent bodily injury or death from the unexpected start-up of the machine, always stop the engine and remove the key from the ignition before making adjustments to the machine.

1. Lower the rotary disc pull-type fully.
2. Shut down the engine, and remove the key from the ignition.
3. Proceed according to the conditioner option on the rotary disc pull-type:
 - Steel or polyurethane conditioners: *3.4.1 Installing Tool Storage Bracket – Steel and Polyurethane Conditioners, page 23*
 - Finger conditioners: *3.4.2 Installing Tool Storage Bracket – Finger Conditioners, page 25*

3.4.1 Installing Tool Storage Bracket – Steel and Polyurethane Conditioners

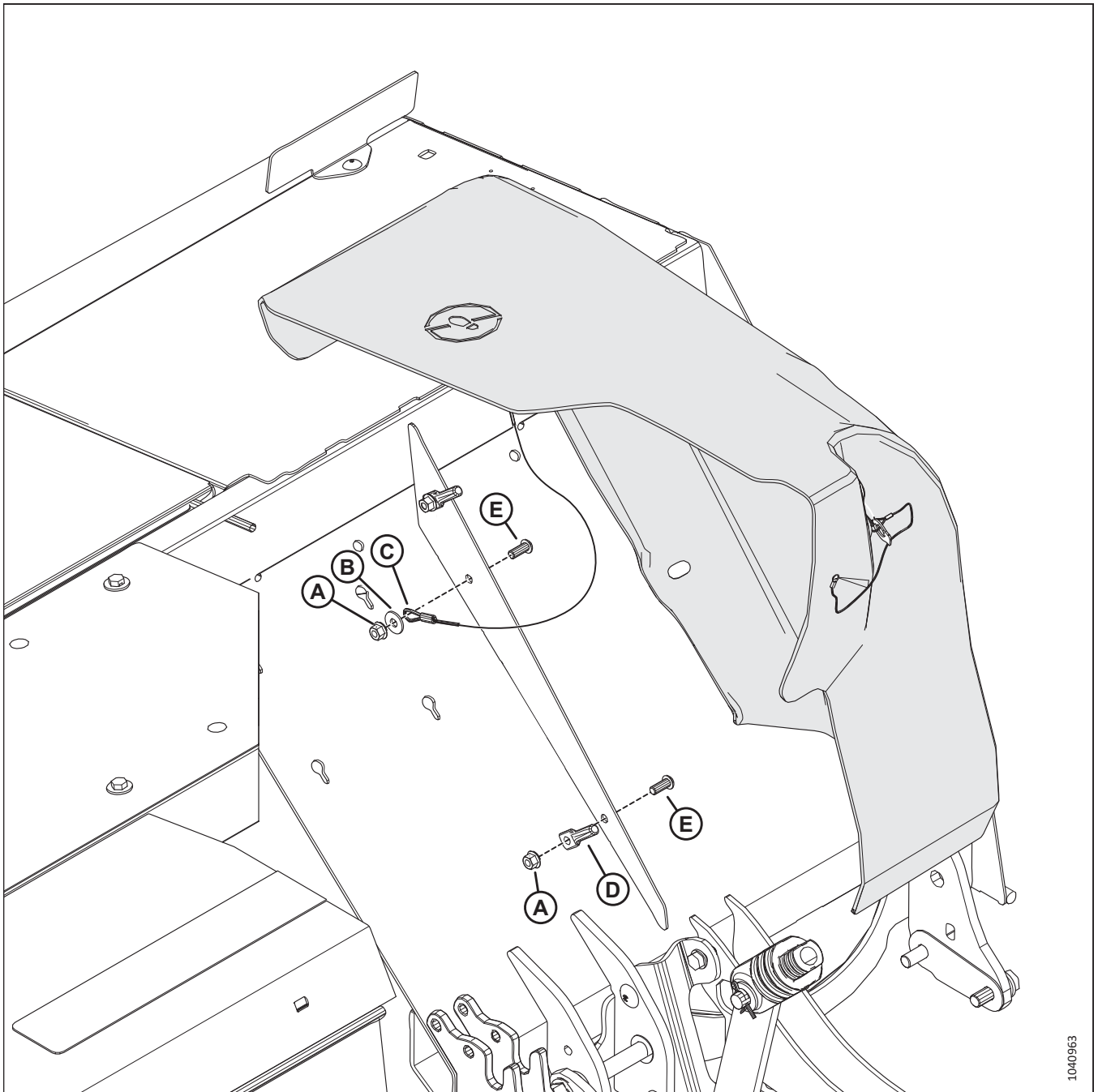

Figure 3.33: Removal of Right Driveshield Mounting Parts

1. Remove the right driveshield. For instructions, refer to the rotary disc pull-type technical manual.
2. Remove two nuts (A), washer (B), driveshield tether (C), driveshield stud (D), and two bolts (E). Discard nuts (A) and bolts (E).

NOTE:

The manual case is hidden for clarity.

INSTALLATION INSTRUCTIONS

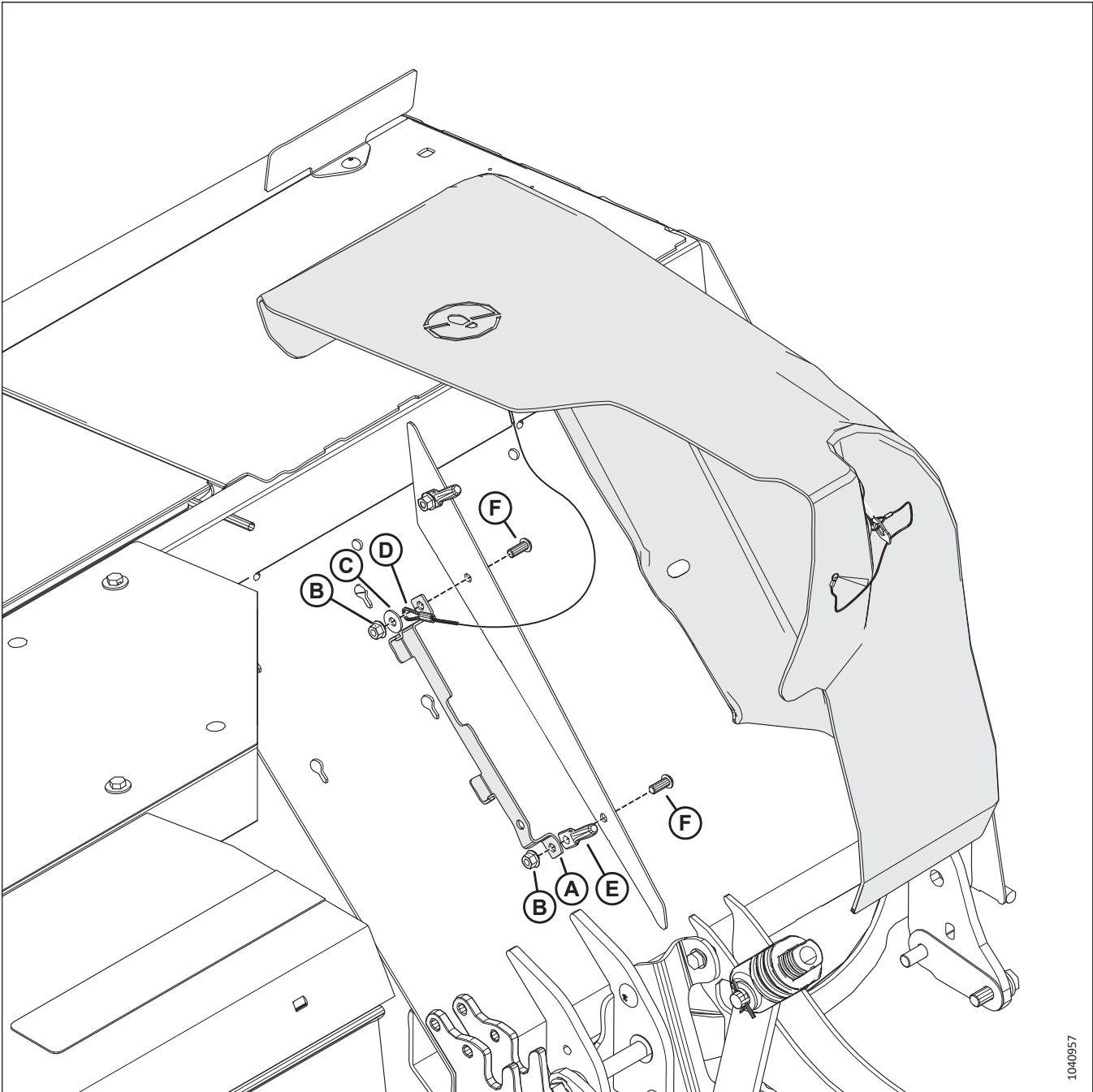

Figure 3.34: Installation of Quick Change Blade Tool Bracket

3. Install bracket (A) (MD #183866), two nuts (B) (MD #135799), washer (C), driveshield tether (D), driveshield stud (E), and two bolts (F) (MD #135852).
4. Tighten nuts (B) to 54 Nm (40 lbf-ft).

3.4.2 Installing Tool Storage Bracket – Finger Conditioners

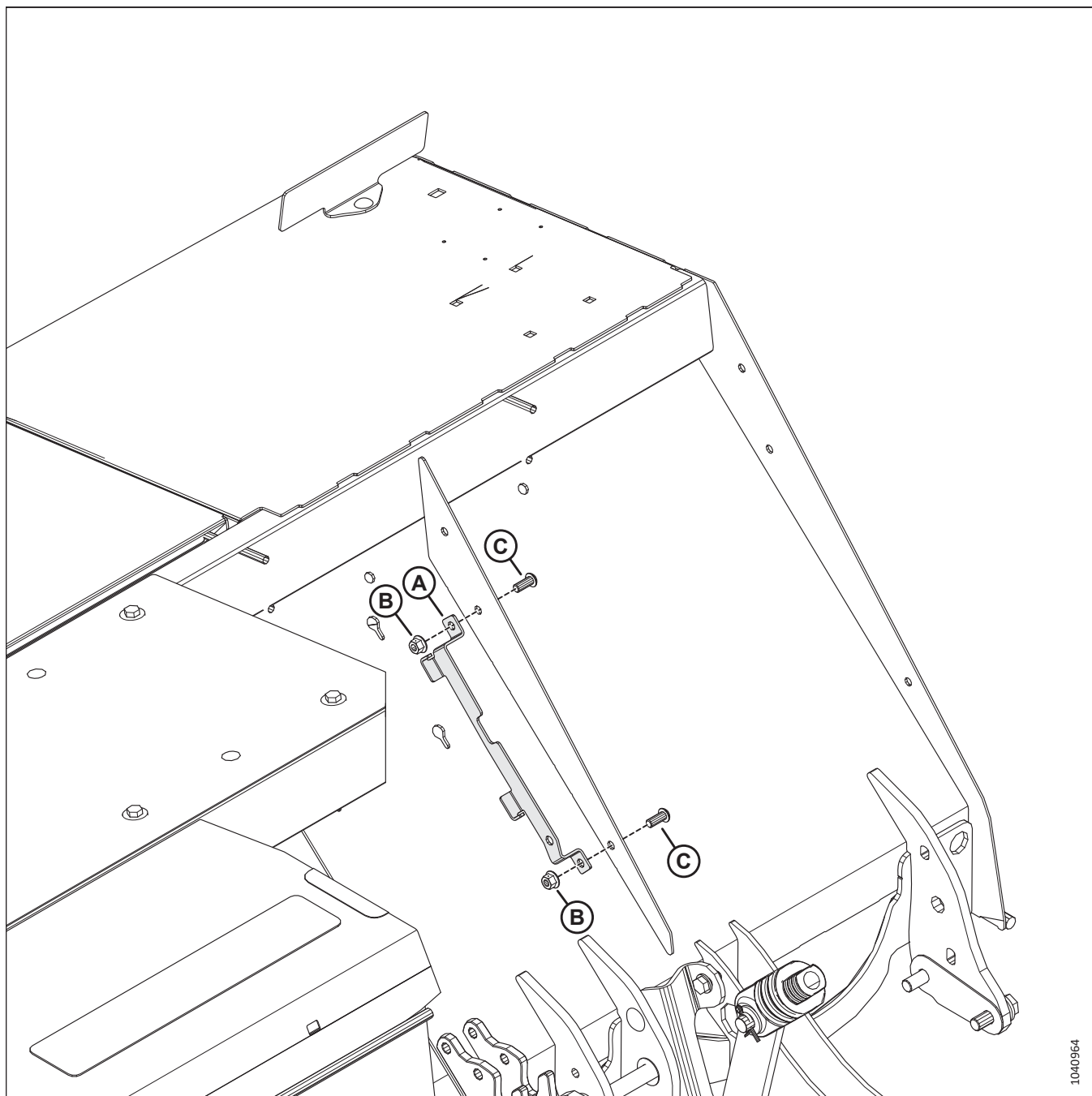

Figure 3.35: Installation of Quick Change Blade Tool Bracket

NOTE:

The manual case is hidden for clarity.

1. Install bracket (A) (MD #183866) using two nuts (B) (MD #135799) and two bolts (C) (MD #135852).
2. Tighten nuts (B) to 54 Nm (40 lbf-ft).

3.5 Storing Quick Change Blade Tool

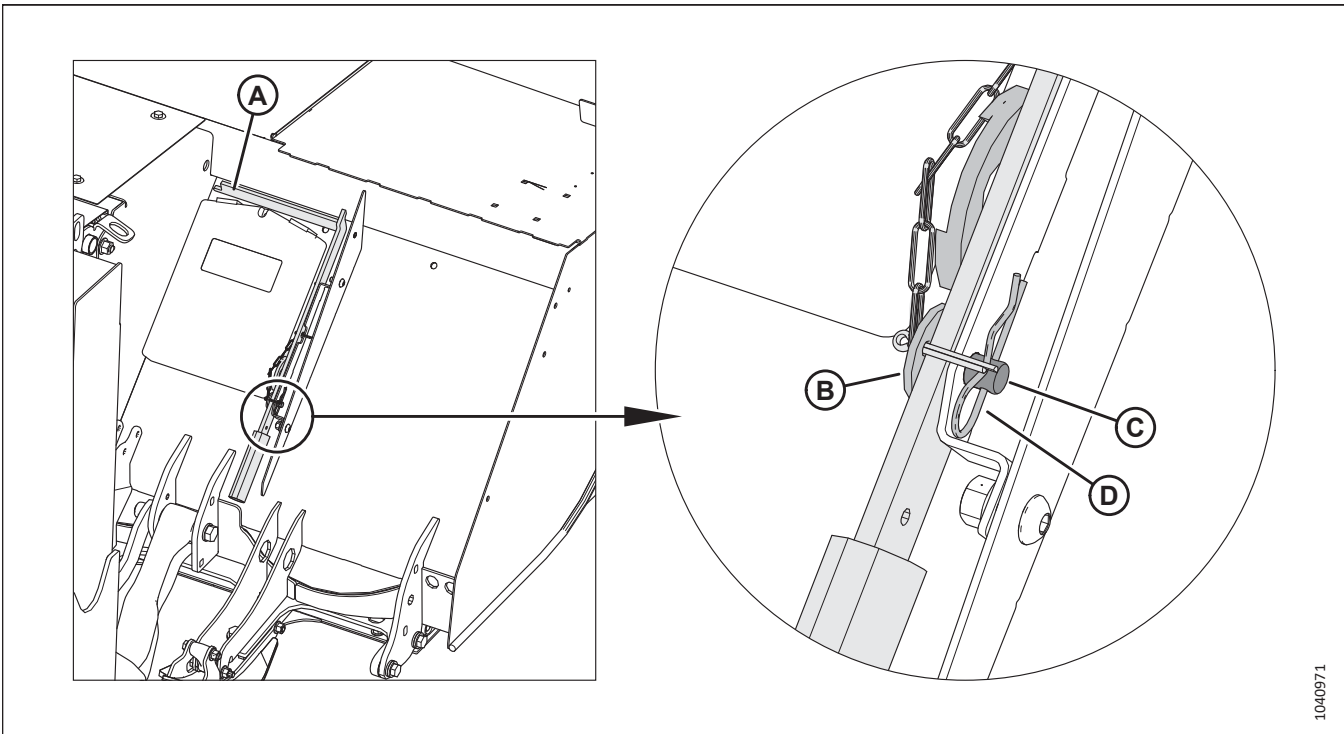

Figure 3.36: Manual Storage Case Location

1. Seat tool (A) in the storage bracket as shown.
2. Align the hole in quick change gauge (B) with the hole in the tool and the hole in the storage bracket.
3. Install pin (C) (MD #281931) through the mounting holes.
4. Install hairpin clip (D) (MD #15380) in pin (C).
5. **If equipped with steel or polyurethane conditioners:** Install the right driveshield. For instructions, refer to the rotary disc pull-type technical manual.

MacDon®

CUSTOMERS
MacDon.com

DEALERS
Portal.MacDon.com

Trademarks of products are the marks of their
respective manufacturers and/or distributors.

Printed in Canada