

FM100 Float Module

Dual Sensor Auto Header Height Control (AHC) Kit
(MD #B6211) Installation Instructions

214143 Revision F

Original Instruction

FM100 Float Module

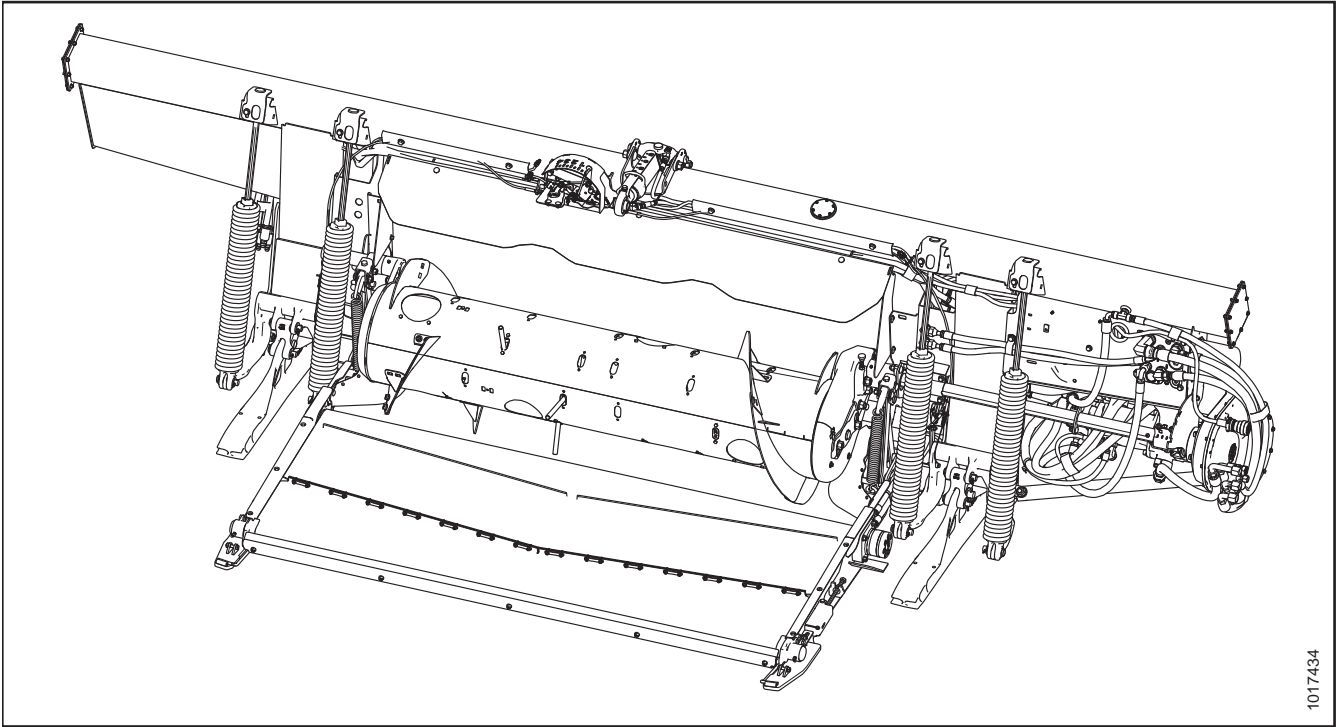

1017434

Published August 2019

© 2019 MacDon Industries, Ltd.

The information in this publication is based on the information available and in effect at the time of printing. MacDon Industries, Ltd. makes no representation or warranty of any kind, whether expressed or implied, with respect to the information in this publication. MacDon Industries, Ltd. reserves the right to make changes at any time without notice.

Introduction

The Dual Sensor Auto Header Height Control (AHHC) kit (MD #B6211) for the FM100 Float Module is designed for use with combines that have lateral tilt capability. This kit allows lateral tilt to work with auto header height control.

IMPORTANT:

The Dual Sensor AHHC kit is **NOT** compatible with New Holland combines with a 10 volt system.

A list of parts included in the kit is provided in Chapter *2 Parts List, page 5*.

Installation time

The approximate installation time for this kit is 1.5 hours.

Conventions

The following conventions are used in this document:

- Right and left are determined from the operator's position. The front of the float module is the side that faces the crop; the back of the float module is the side that connects to the combine.
- Unless otherwise noted, use the standard torque values provided in the header operator's manual and technical manual.

NOTE:

Keep your MacDon publications up-to-date. The most current version of this instruction can be downloaded from our Dealer-only site (<https://portal.macdon.com>) (login required).

NOTE:

This document is currently available in English only.

Summary of Changes

At MacDon, we're continuously making improvements, and occasionally these improvements affect product documentation. The following list provides an account of major changes from the previous version of this document.

Section	Summary of Change	Internal Use Only
—	Revised instruction format to include front and back covers, and safety section.	Tech Pubs
<i>2 Parts List, page 5</i>	Revised parts illustration to make it easier to distinguish between the left and the right sensor assemblies.	Support
<i>3 Installation Instructions, page 7</i>	<ul style="list-style-type: none"> • Added steps and illustration for identifying the left and right sensor assemblies. • Added note to ensure the connector is facing down and the sensor arm arrow is facing the combine. • Added step to ensure the rubber boot is attached to the cable adjuster nut. • Reordered steps so that the harness gets fully installed before securing. After the harness is installed, and it gets secured from the float indicator box and working down to the sensor. • Added step to set the float and wing balance before calibrating the AHHC system. • Added note that if the combine sees the center sensor (except John Deere), then connector C40 on the FM100 main harness is not connected. • Added photos taken during an install to help clarify the procedure. 	Support
<ul style="list-style-type: none"> • <i>4.1 Manually Checking Voltage Range – Two-Sensor System, page 17</i> • <i>4.2 Adjusting Voltage Limits – Two-Sensor System, page 21</i> • <i>4.3 Sensor Output Voltage Range – Combine Requirements, page 24</i> 	Added Troubleshooting topics.	Support

TABLE OF CONTENTS

Introduction i

Summary of Changes..... ii

Chapter 1: Safety 1

 1.1 Signal Words 1

 1.2 General Safety 2

Chapter 2: Parts List..... 5

Chapter 3: Installation Instructions 7

Chapter 4: Troubleshooting..... 17

 4.1 Manually Checking Voltage Range – Two-Sensor System 17

 4.2 Adjusting Voltage Limits – Two-Sensor System..... 21

 4.3 Sensor Output Voltage Range – Combine Requirements..... 24

Chapter 1: Safety

1.1 Signal Words

Three signal words, **DANGER**, **WARNING**, and **CAUTION**, are used to alert you to hazardous situations. Two signal words, **IMPORTANT** and **NOTE**, identify non-safety related information. Signal words are selected using the following guidelines:

DANGER

Indicates an imminently hazardous situation that, if not avoided, will result in death or serious injury.

WARNING

Indicates a potentially hazardous situation that, if not avoided, could result in death or serious injury. It may also be used to alert against unsafe practices.

CAUTION

Indicates a potentially hazardous situation that, if not avoided, may result in minor or moderate injury. It may be used to alert against unsafe practices.

IMPORTANT:

Indicates a situation that, if not avoided, could result in a malfunction or damage to the machine.

NOTE:

Provides additional information or advice.

1.2 General Safety

CAUTION

The following general farm safety precautions should be part of your operating procedure for all types of machinery.

Protect yourself.

- When assembling, operating, and servicing machinery, wear all protective clothing and personal safety devices that could be necessary for the job at hand. Do **NOT** take chances. You may need the following:
 - Hard hat
 - Protective footwear with slip-resistant soles
 - Protective glasses or goggles
 - Heavy gloves
 - Wet weather gear
 - Respirator or filter mask
- Be aware that exposure to loud noises can cause hearing impairment or loss. Wear suitable hearing protection devices such as earmuffs or earplugs to help protect against loud noises.



Figure 1.1: Safety Equipment



Figure 1.2: Safety Equipment

- Provide a first aid kit in case of emergencies.
- Keep a properly maintained fire extinguisher on the machine. Be familiar with its proper use.
- Keep young children away from machinery at all times.
- Be aware that accidents often happen when the Operator is tired or in a hurry. Take time to consider safest way. **NEVER** ignore warning signs of fatigue.

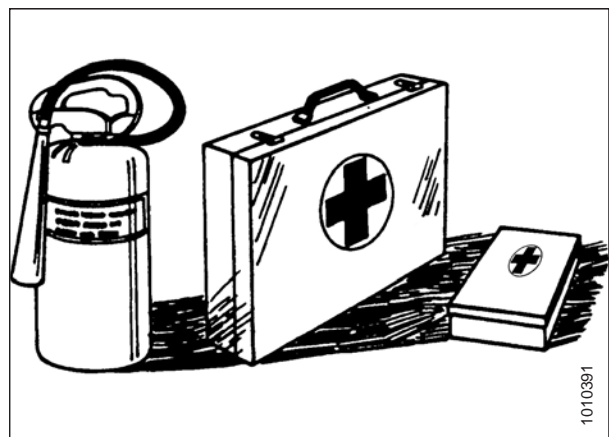

Figure 1.3: Safety Equipment

SAFETY

- Wear close-fitting clothing and cover long hair. **NEVER** wear dangling items such as scarves or bracelets.
- Keep all shields in place. **NEVER** alter or remove safety equipment. Make sure driveline guards can rotate independently of shaft and can telescope freely.
- Use only service and repair parts made or approved by equipment manufacturer. Substituted parts may not meet strength, design, or safety requirements.



Figure 1.4: Safety around Equipment

- Keep hands, feet, clothing, and hair away from moving parts. **NEVER** attempt to clear obstructions or objects from a machine while the engine is running.
- Do **NOT** modify the machine. Unauthorized modifications may impair machine function and/or safety. It may also shorten the machine's life.
- To avoid injury or death from unexpected startup of the machine, **ALWAYS** stop the engine and remove the key from the ignition before leaving the operator's seat for any reason.

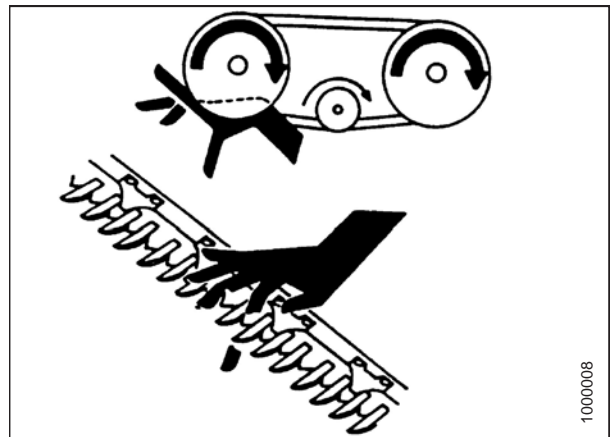

Figure 1.5: Safety around Equipment

- Keep service area clean and dry. Wet and/or oily floors are slippery. Wet spots can be dangerous when working with electrical equipment. Be sure all electrical outlets and tools are properly grounded.
- Keep work area well lit.
- Keep machinery clean. Straw and chaff on a hot engine are fire hazards. Do **NOT** allow oil or grease to accumulate on service platforms, ladders, or controls. Clean machines before storage.
- **NEVER** use gasoline, naphtha, or any volatile material for cleaning purposes. These materials may be toxic and/or flammable.
- When storing machinery, cover sharp or extending components to prevent injury from accidental contact.



Figure 1.6: Safety around Equipment

Chapter 2: Parts List

The following parts are included in this kit:

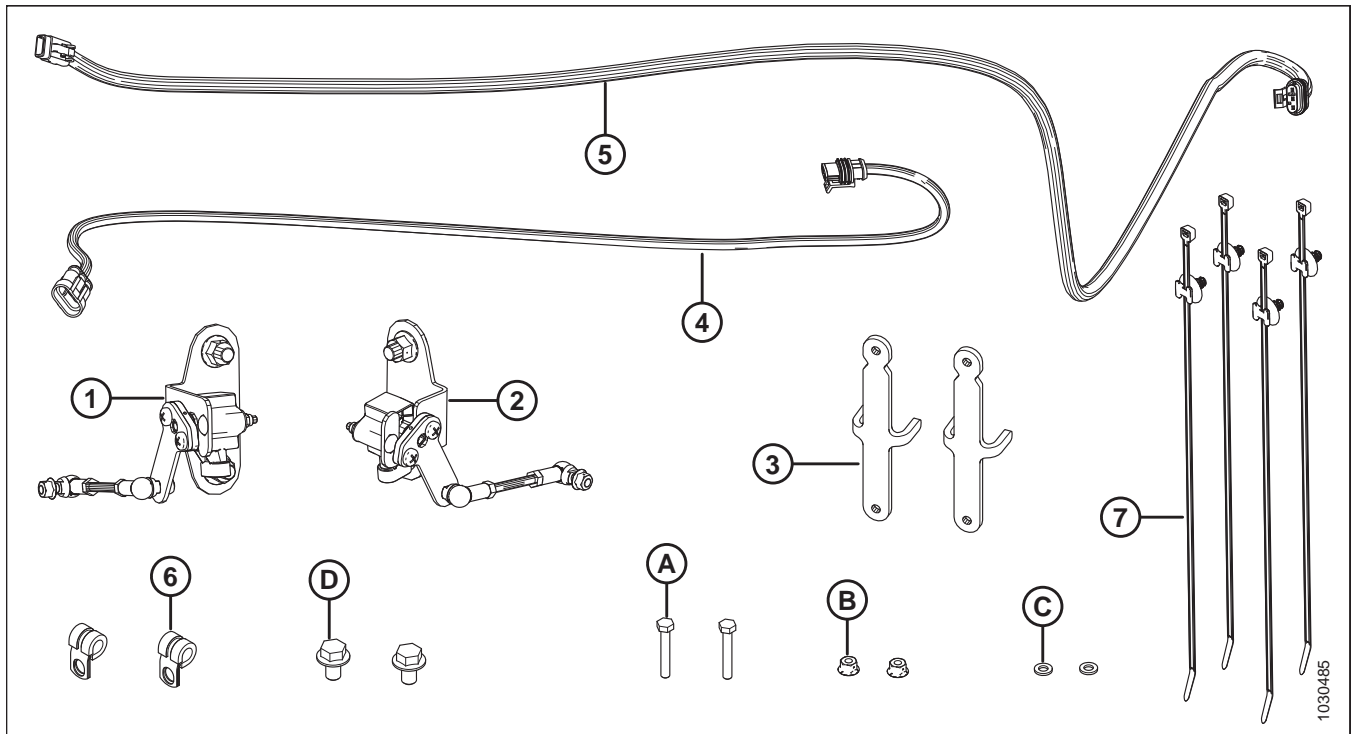

Ref	Part Number	Description	Quantity
1	NSS ¹	AHHC SENSOR ASSEMBLY, LH	1
2	NSS ¹	AHHC SENSOR ASSEMBLY, RH	1
3	295179	BRACKET – SENSOR LINK	2
4	276201	HARNESS – LH HEIGHT SENSOR	1
5	276871	HARNESS – RH HEIGHT SENSOR	1
6	136410	CLAMP – INSULATED 3/8 IN.	2
7	136655	FASTENER – FIR TREE MT W/ TIE	4
A	135671	BOLT – HEX HD TFL M6 X 1 X 40-8.8-A2L	2
B	152668	NUT – HEX FLG CTR LOC M6 X 1-8-A2L	2
C	184705	WASHER – FLAT M6-200HV-A2L	2
D	136151	BOLT – HEX FLG HD TFL M10 X 1.5 X 16-8.8-A3L	2

1. Not sold separately. Refer to the parts catalog if ordering replacement components for sensor assemblies.

Chapter 3: Installation Instructions

DANGER

To avoid bodily injury or death from unexpected start-up or fall of a raised machine, always stop engine and remove key before leaving the operator's seat, and always engage safety props before going under the machine for any reason.

To install the Dual Sensor AHHC kit (MD #B6211), follow these steps:

NOTE:

Unless otherwise stated, all parts are provided in the kit.

1. Raise the reel to full height, and engage the safety props.

NOTE:

The header is removed from the illustrations for clarity. The kit is installed with the float module attached to the header.

2. Shut down the combine, and remove the key from the ignition.

IMPORTANT:

Before installing the sensor assemblies, make sure you correctly identify which assembly is for the left side and which assembly is for the right side. The sensor assemblies **MUST** be installed in the correct locations for the dual sensor system to work correctly.

3. Hold up the assembly so that the sensor connector (A) is pointing down and the mounting bolt heads (B) are facing away from you.
 - The left sensor assembly (L) has the linkage (C) to the left of the sensor.
 - The right sensor assembly (R) has the linkage (C) to the right of the sensor.

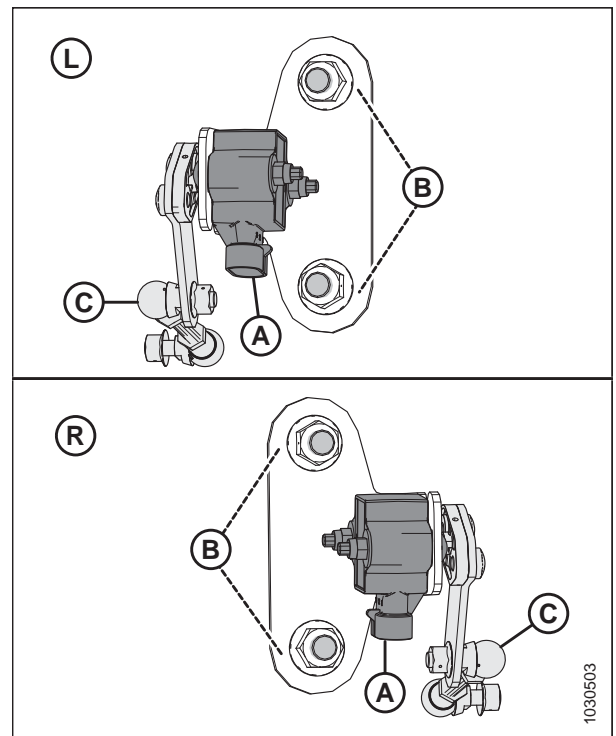

Figure 3.1: Left and Right Sensor Assemblies

INSTALLATION INSTRUCTIONS

- Remove the nut from bolt (A), and leave the bolt, washer, and float indicator cable (B) attached to float lever (C).

NOTE:

Unless otherwise stated, illustrations in this procedure show the installation of the right side sensor assembly (not sold separately).

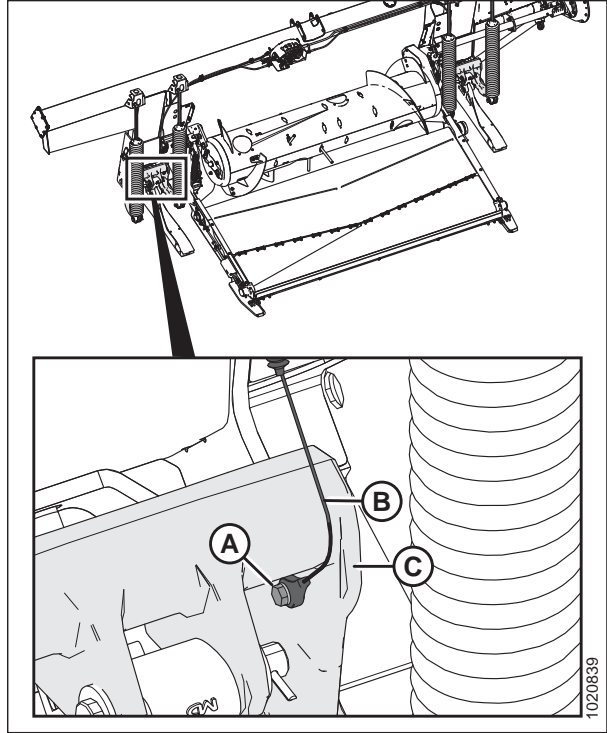

Figure 3.2: Float Indicator Cable

- Install sensor link bracket (A) (MD #295179) arms into hole (B) at the top of the float lever, with the indented end of the bracket facing up.

NOTE:

The sensor link bracket arms fit snugly inside the hole of the float lever. If required, use a mallet to tap brackets into place.

- Align hole (C) in the bottom of the bracket with the hole in the float lever where the nut was removed in Step 4, [page 8](#).

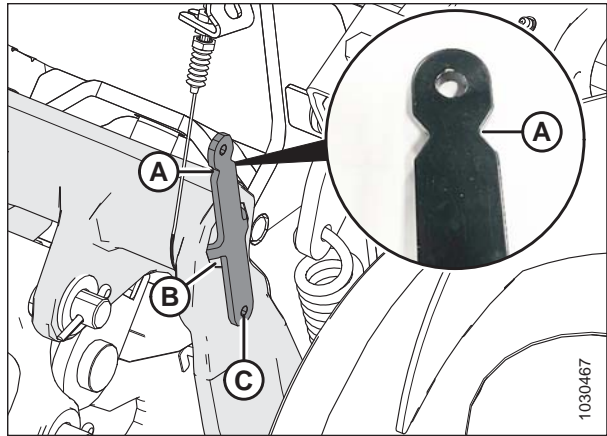

Figure 3.3: Installing Sensor Link Bracket

INSTALLATION INSTRUCTIONS

7. Hold cable (E) in place, and replace bolt (C) and washer (D) with bolt (MD #135671) and washer (MD #184705) supplied in the kit.
8. Install nut (A) (MD #152668) to secure the sensor link bracket (B) to the float lever. Ensure washer (D) is between bolt (C) and cable (E).
9. Ensure cable eye (E) is not twisted, and then fully tighten bolt (C).

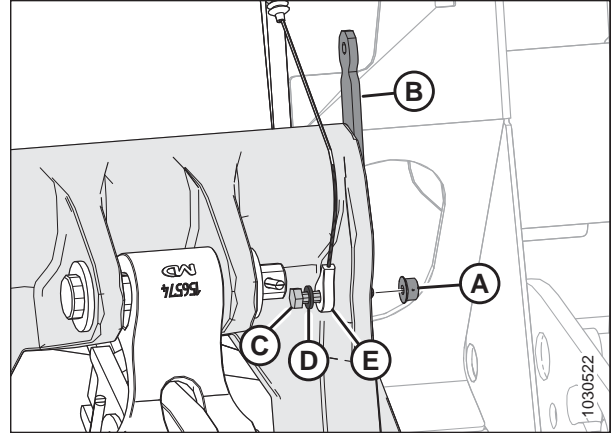

Figure 3.4: Installing Sensor Link Bracket

10. Check if jam nuts (A) are tight against the two ball joints of the right sensor assembly. If jam nuts are not secured, tighten to 12 Nm (9 lbf-ft).

IMPORTANT:

Measurement (B) should be 50.4 mm (1 31/32 in.).
Incorrect measurement will lead to equipment damage.

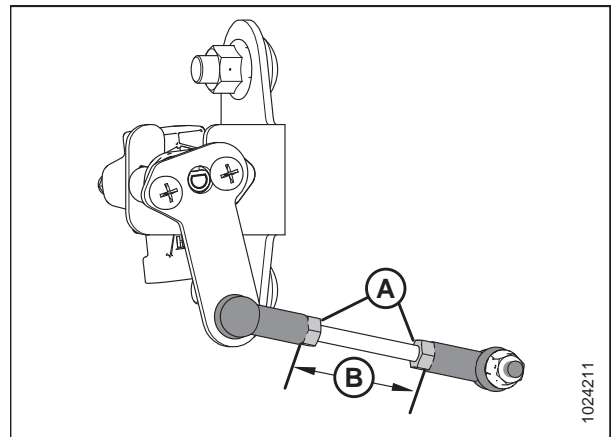

Figure 3.5: Right Sensor Assembly

IMPORTANT:

The sensor is to be installed with electrical connector (A) facing down and sensor arm arrow (the pointed end) (B) facing the combine.

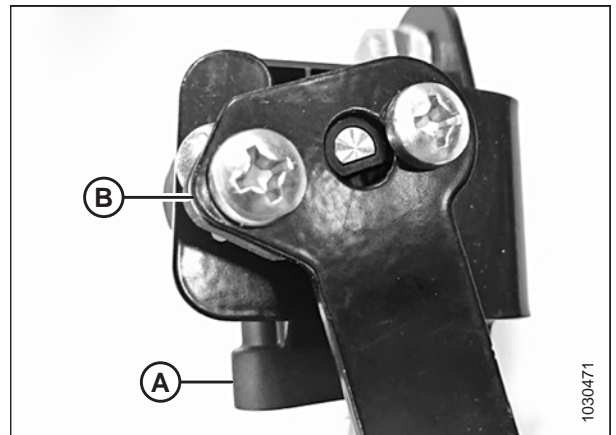

Figure 3.6: Right Sensor Assembly

INSTALLATION INSTRUCTIONS

11. With the sensor assembly positioned inside the right side of the frame, route sensor assembly linkage (C) through frame opening (D) and out toward the front of the header.

IMPORTANT:

The sensor assemblies must be installed on the back side of the float module.

12. Install the right sensor assembly (A) onto the rear of the float module frame as shown, with bolts (B) on the assembly slotted into place on the frame. Make sure the sensor connector faces down.

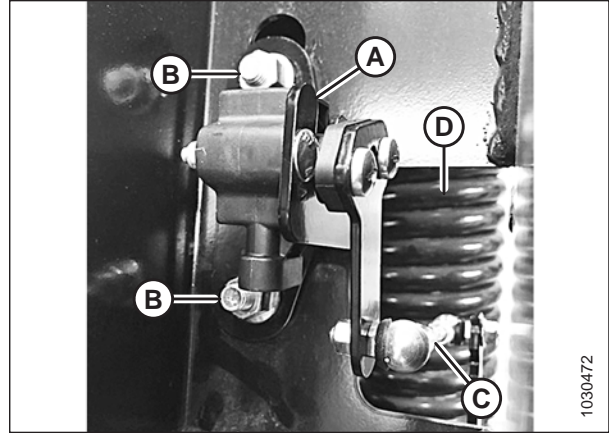

Figure 3.7: Installing Right Sensor Assembly

13. Remove nut (A) from the sensor assembly ball joint, then attach sensor linkage (B) to the top of sensor link bracket (C) and reinstall nut (A). Tighten to 12 Nm (9 lbf-ft).

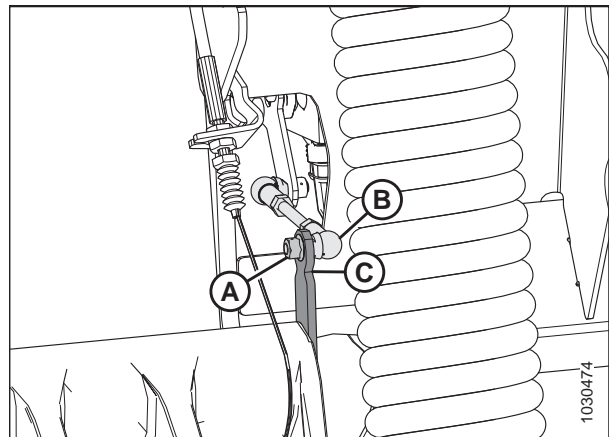

Figure 3.8: Installing Right Sensor Assembly

14. Ensure rubber boot (A) is attached to the cable adjuster nut (B).

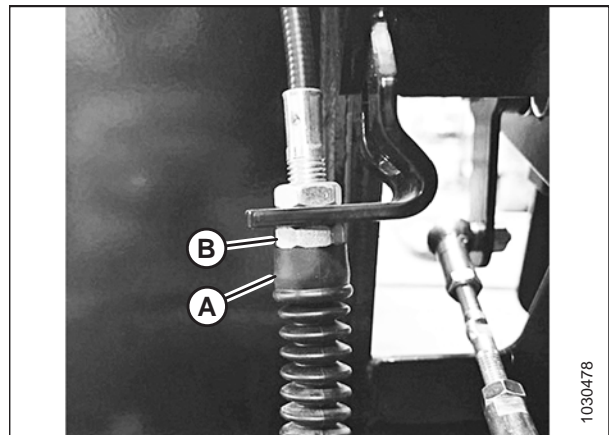

Figure 3.9: Installing Right Sensor Assembly

INSTALLATION INSTRUCTIONS

- Repeat Step 3, page 7 to Step 14, page 10 to install the left sensor assembly (A).

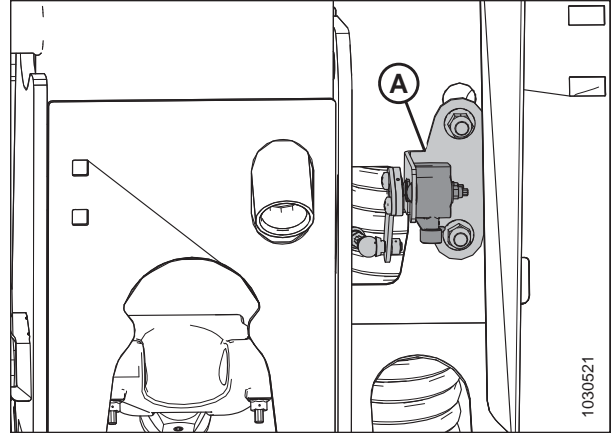

Figure 3.10: Left Sensor Assembly Installed

- Connect right sensor harness (A) (MD #276871) to the right sensor.
- Route the right sensor harness up inside the frame as shown.

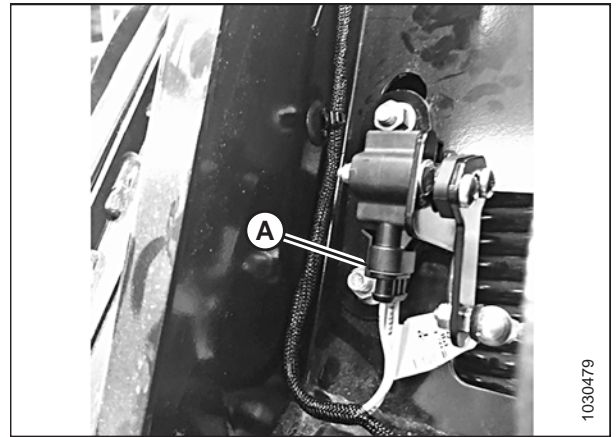

Figure 3.11: Installing Right Sensor Harness

- Continue routing right sensor harness (A) along the front of frame toward the float indicator box (B) and connect to connector P539 (C) on the FM100 main harness.

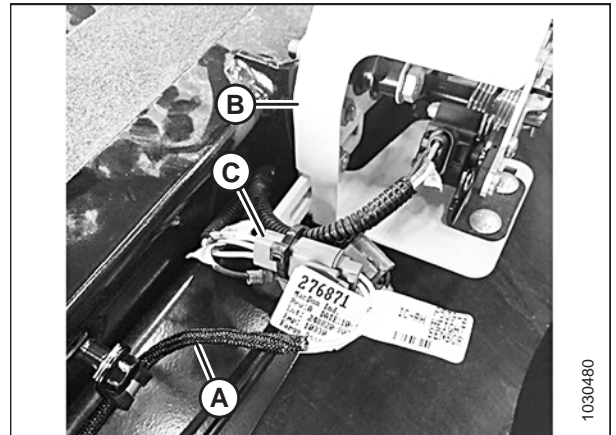

Figure 3.12: Installing Right Sensor Harness

INSTALLATION INSTRUCTIONS

19. Secure harness (A) to the front of the frame using two clamps (MD #136410) and bolts (MD #136151). Install clamp at location (B) first, then at location (C).

NOTE:

Clamp (C) attaches to existing clamp that secures the float indicator cable to the frame.

NOTE:

Do **NOT** route the float indicator cable through clamp (B).

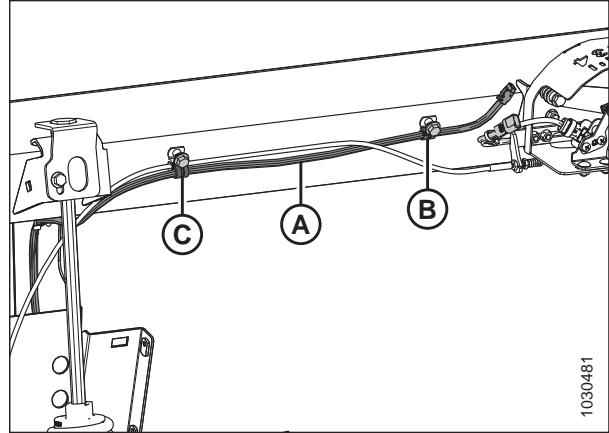

Figure 3.13: Installing Right Sensor Harness

20. Secure the right sensor harness (A) to the inside frame using fastener (B) (MD #136655).

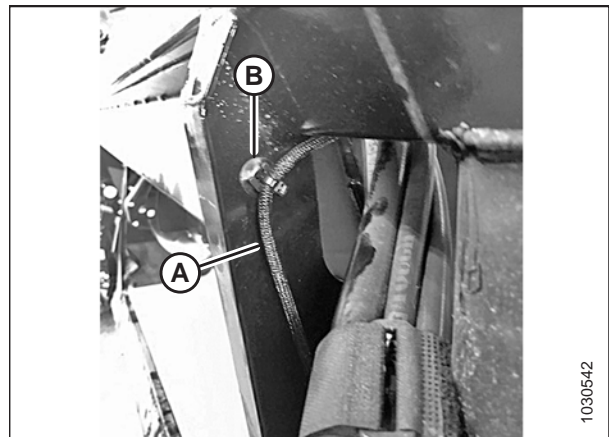

Figure 3.14: Securing Right Sensor Harness

21. Near the sensor connection, secure the right sensor harness to the inside frame using fastener (A) (MD #136655).



Figure 3.15: Securing Right Sensor Harness

INSTALLATION INSTRUCTIONS

22. Connect left sensor harness (A) (MD #276201) to left sensor (B).

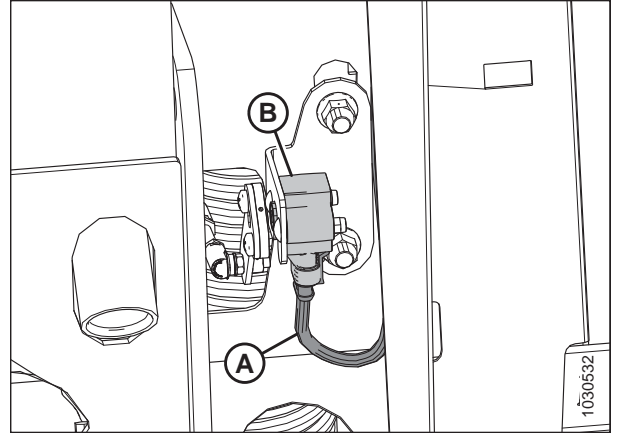

Figure 3.16: Installing Left Sensor Harness

23. Route left sensor harness (A) up inside the frame as shown, between the frame and hydraulic hoses (B).

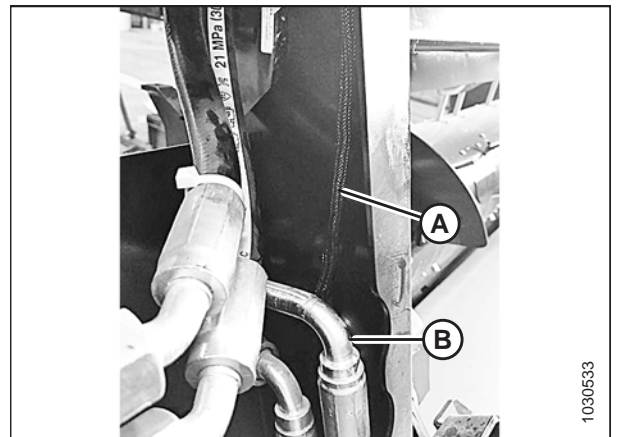

Figure 3.17: Installing Left Sensor Harness

24. Near the inner float spring (B) on the left side of the float module, locate plug P537 (A) on the FM100 main harness, and remove the cap.

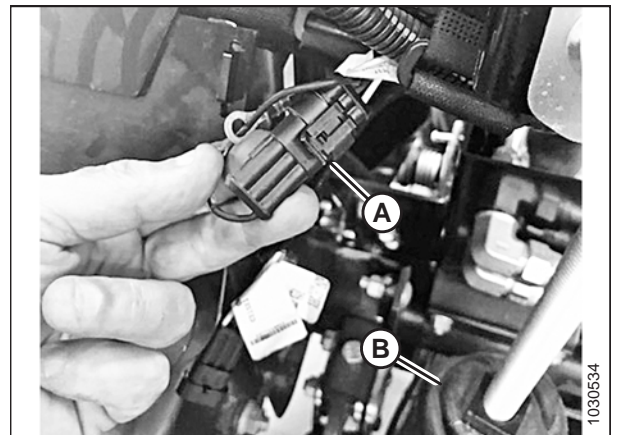

Figure 3.18: FM100 Main Harness P537

INSTALLATION INSTRUCTIONS

25. Connect left sensor harness connector (B) to plug P537 (A) on the FM100 main harness.

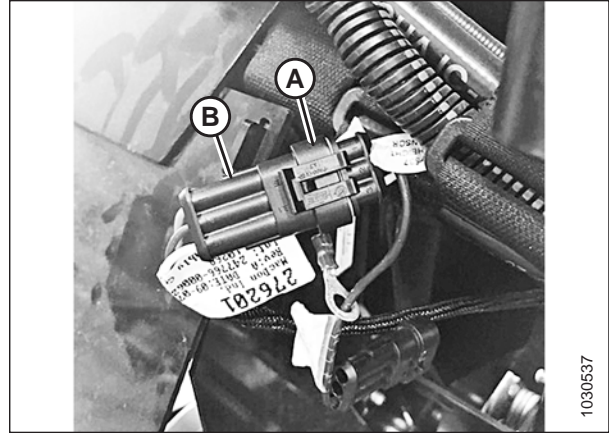

Figure 3.19: FM100 Harness P537 and Left Sensor Harness Connector

26. Secure the top end of the left sensor harness to the inside frame using fastener (A) (MD #136655).

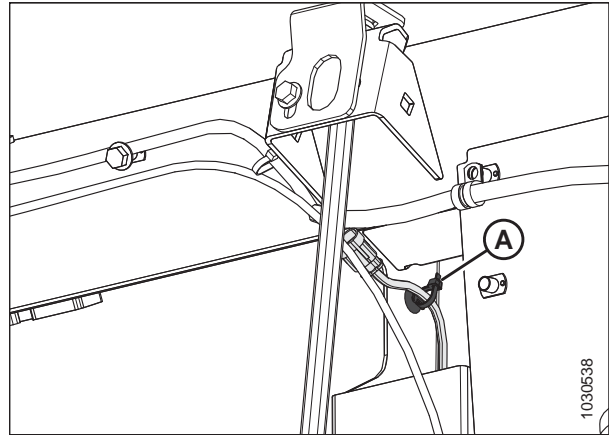

Figure 3.20: Securing Left Sensor Harness

27. Near the sensor connection (A), secure the left sensor harness to the inside frame using fastener (B) (MD #136655).

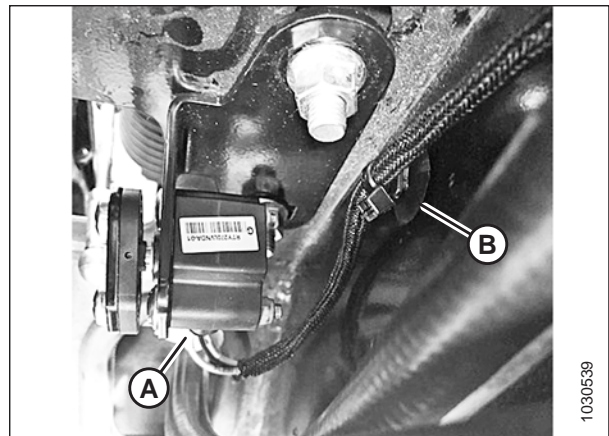

Figure 3.21: Securing Left Sensor Harness

INSTALLATION INSTRUCTIONS

28. To operate the two-sensor system, connector C40 (A) on the FM100 main harness needs to be connected to the combine completion harness.

Case New Holland (CNH):

- Cut the cable tie at plug C45B (B) on the completion harness.
- Disconnect connector C45A from plug C45B (B).
- Near the selector valve manifold, locate connector C40 (A) on the FM100 main harness, and remove the cap.
- Tuck the sensor harness behind main harness (C) and then connect plug C45B (B) to connector C40 (A).

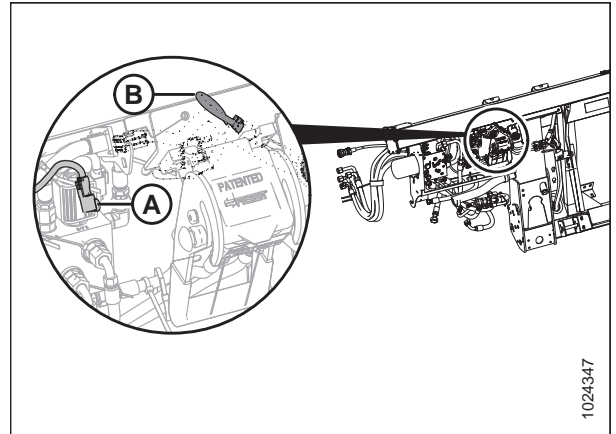

Figure 3.22: FM100 Harness C40 Connector and CNH Completion Harness C45B Plug

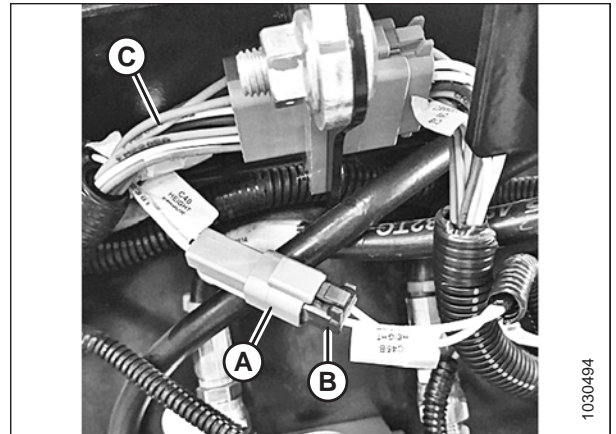

Figure 3.23: FM100 Harness C40 Connector and CNH Completion Harness C45B Plug

CLAAS:

- Disconnect plug C42A from connector C42B (B) on the completion harness.
- Connect plug C42A to connector C40 (A) on the FM100 main harness.

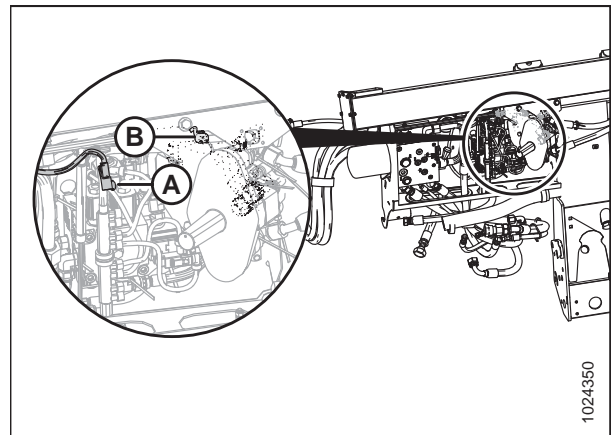

Figure 3.24: FM100 Harness C40 Connector and CLAAS Completion Harness C42A Plug

INSTALLATION INSTRUCTIONS

Challenger, Gleaner, and Massey Ferguson:

- a. Disconnect plug C41A from connector C41B (B) on the completion harness.
- b. Connect plug C41A to connector C40 (A) on the FM100 main harness.

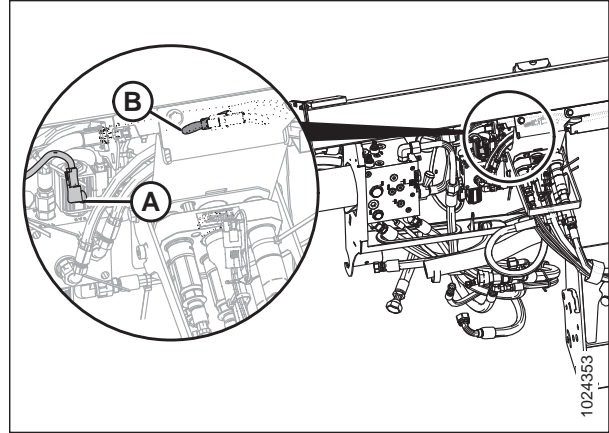

Figure 3.25: FM100 Harness C40 Connector and Challenger Completion Harness C41A Plug

John Deere: Plug C43 on the completion harness is connected to connector C40 on the FM100 main harness from the factory; no connections need to be changed to operate the two-sensor system.

29. Before calibrating the AHHC system, set float and wing balance. A light float will affect AHHC calibration and system performance. For instructions, refer to the header operator's manual.
30. For instructions on checking/adjusting sensor voltage, refer to [4 Troubleshooting, page 17](#).
31. For instructions on calibrating the AHHC system, refer to the header operator's manual or technical manual.

IMPORTANT:

On all combines except for John Deere, if the combine sees the center sensor then connector C40 on the FM100 main harness has not been connected. Plug C40 **MUST** be connected in order for the combine to recognize the left and right sensors.

Chapter 4: Troubleshooting

4.1 Manually Checking Voltage Range – Two-Sensor System

FM100 Float Modules equipped with the optional two-sensor system have a left and right sensor located on the back frame of the float module.

WARNING

To avoid injury or death from unexpected start-up of machine, always stop the engine and remove the key from the ignition before leaving the operator's seat for any reason.

Figure 4.1: Sensor Orientation

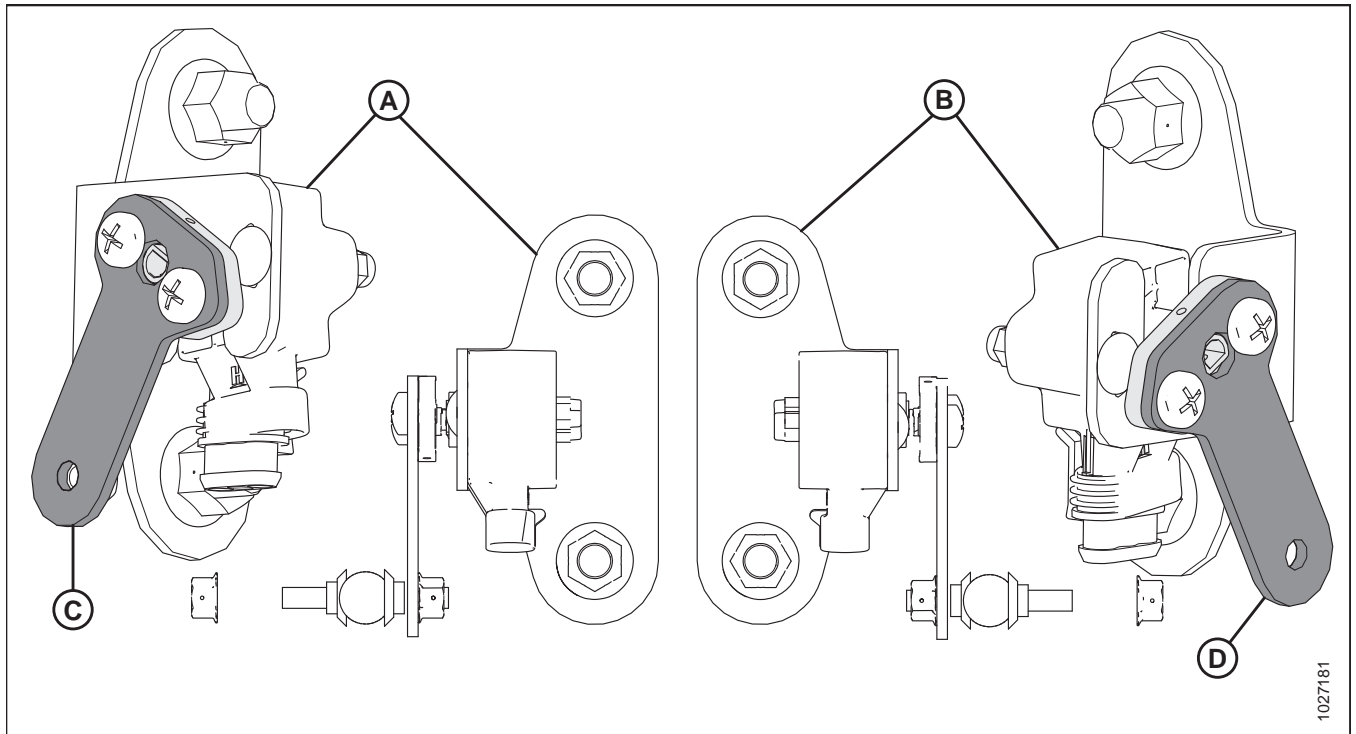

1. Before adjusting the sensors, verify the sensor arms are properly installed on the sensors.
 - Left Sensor (A): The **point** on the arm of the sensor should face **away** from the header. The point on the float sensor arm (C) should be installed in the same direction, facing away from the header.
 - Right Sensor (B): The **point** on the arm of the sensor should face **away** from the header. The point on the float sensor arm (D) should be installed in the same direction, facing away from the header.

To manually check the sensor's output voltage range, follow these steps:

2. Extend guard angle fully; the header angle indicator should be at **D**.
3. Position the header 150 mm (6 in.) above the ground, and unlock the float.

TROUBLESHOOTING

4. Check that float lock linkage is on down stops (washer [A] cannot be moved) at both locations.

NOTE:

If the header is not on down stops during the next two steps, the voltage may go out of range during operation causing a malfunction of the AHHC system.

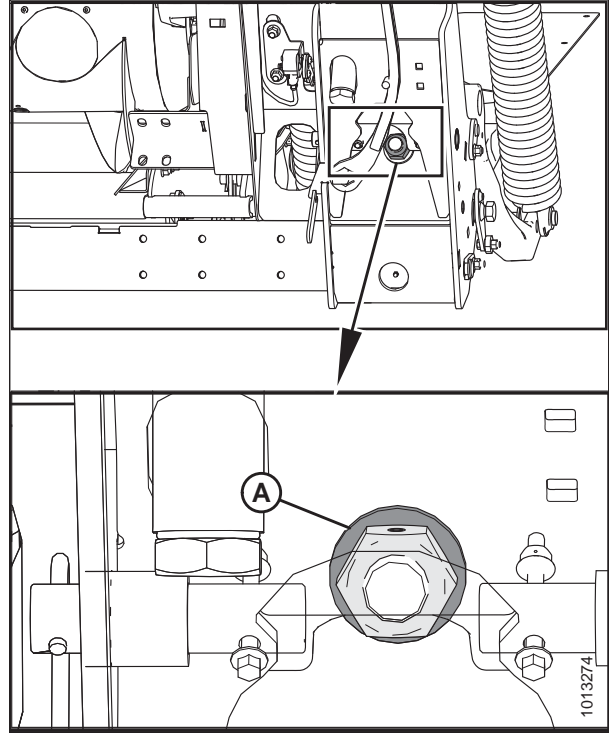

Figure 4.2: Down Stop Washer

5. Locate linkage assembly (A). Verify that dimension (B) is set to 55 mm (2 3/16 in.). If it is not, adjust linkage (A).

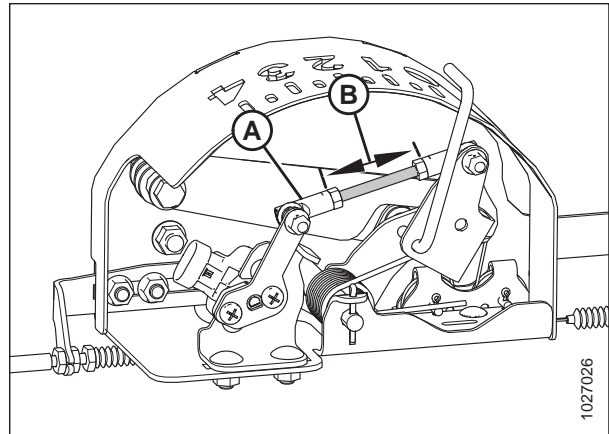

Figure 4.3: Float Indicator Box

TROUBLESHOOTING

- Adjust cable take-up bracket (B) (if necessary) until pointer (A) on the float indicator is on **0**.

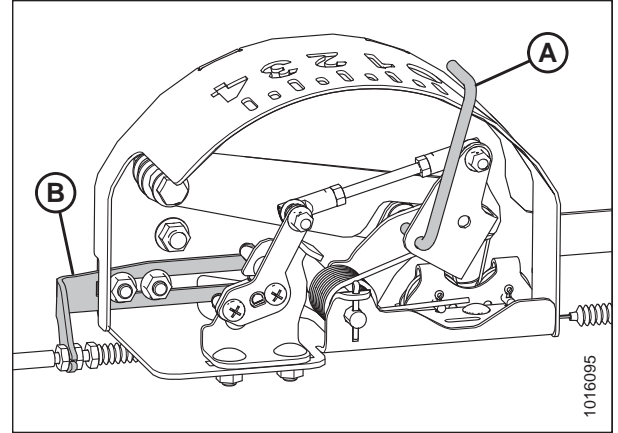

Figure 4.4: Float Indicator Box

- Use a voltmeter to measure the voltage between the ground (Pin 2) and signal (Pin 3) wires of AHHC sensor (A) at the back of the float module side frame. Ensure it is at the high voltage limit for the combine.

NOTE:

The wiring harness connector must be attached to the sensor. Do **NOT** disconnect it.

- Repeat at the opposite side.

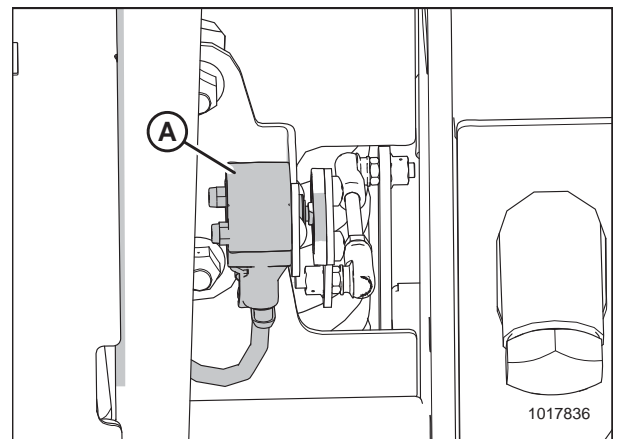

Figure 4.5: Optional Two-Sensor Kit – Right Sensor

- Fully lower the combine feeder house, and float the header up off the down stops (float indicator [A] should be at **4**, and the float module should be fully separated from the header).

NOTE:

You may need to hold the HEADER DOWN switch for a few seconds to ensure the feeder house is fully lowered.

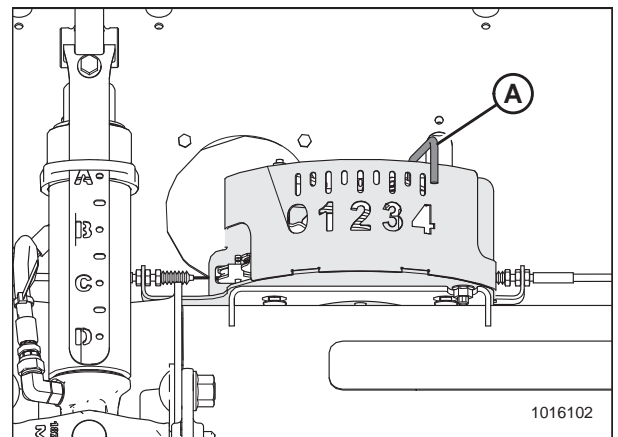

Figure 4.6: Float Indicator Box

TROUBLESHOOTING

- Using a voltmeter, measure the voltage between the ground (Pin 2) and signal (Pin 3) wires of AHC sensor (A) at the back of the side frame. Ensure it is at the low voltage limit for the combine.

NOTE:

The wiring harness connector must be attached to the sensor. Do **NOT** disconnect it.

- If the sensor voltage is not within the low and high limits, or if the range between the low and high limits is insufficient, adjust the voltage limits. For instructions, refer to [4.2 Adjusting Voltage Limits – Two-Sensor System, page 21](#).
- Repeat at the opposite side.

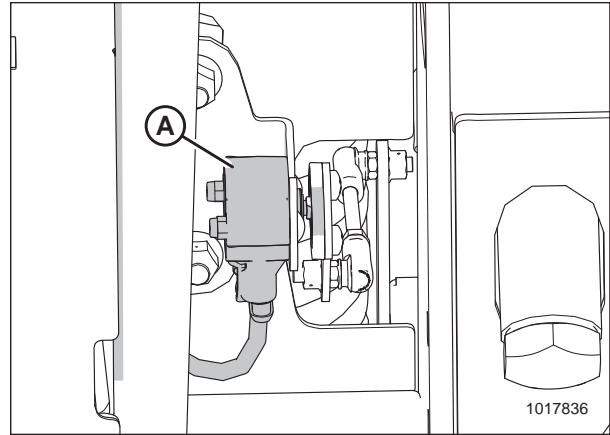

Figure 4.7: Optional Two-Sensor Kit – Right Sensor

4.2 Adjusting Voltage Limits – Two-Sensor System

WARNING

To avoid injury or death from unexpected start-up of machine, always stop the engine and remove the key from the ignition before leaving the operator's seat for any reason.

Figure 4.8: Sensor Orientation

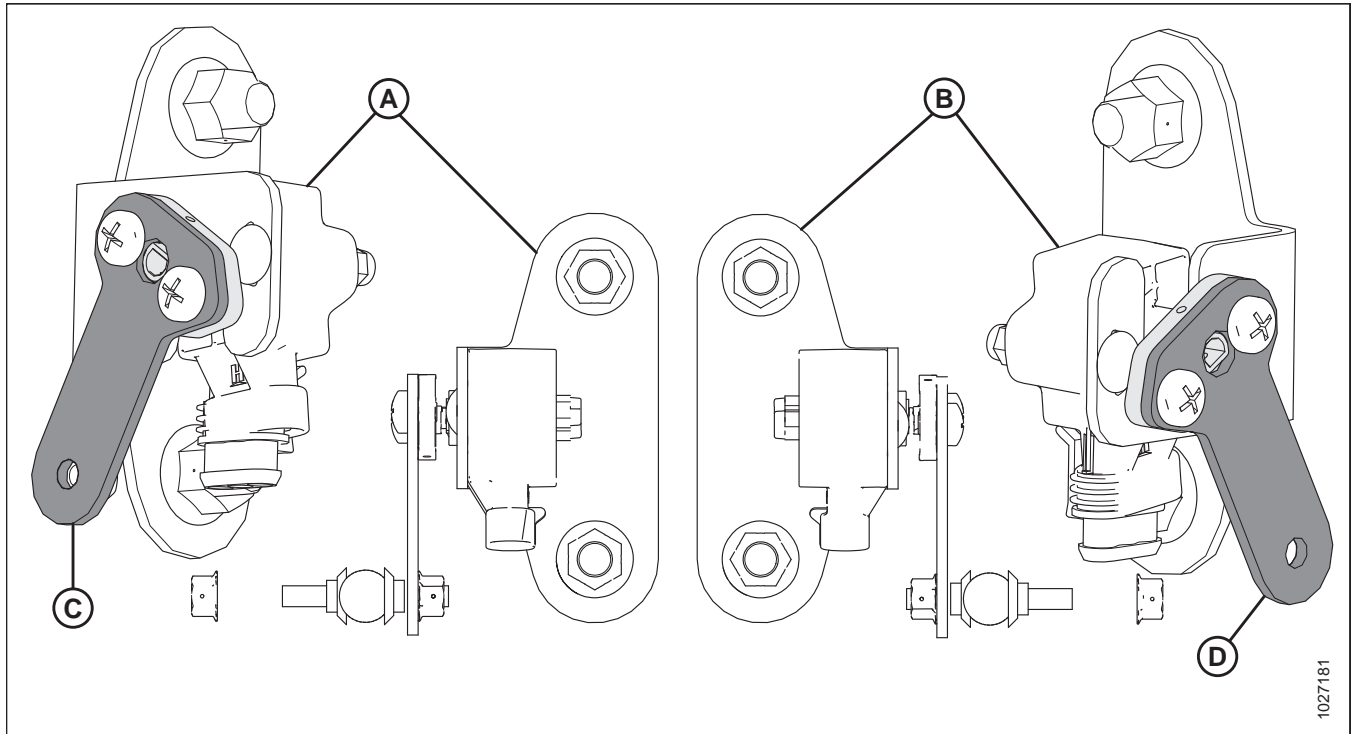

1. Before adjusting the sensors, verify the sensor arms are properly installed on the sensors.
 - Left Sensor (A): The **point** on the arm of the sensor should face **away** from the header. The point on the float sensor arm (C) should be installed in the same direction, facing away from the header.
 - Right Sensor (B): The **point** on the arm of the sensor should face **away** from the header. The point on the float sensor arm (D) should be installed in the same direction, facing away from the header.

TROUBLESHOOTING

Follow these steps to adjust the left sensor voltage:

2. Extend guard angle fully; the header angle indicator should be at **D**.
3. Position header 150–254 mm (6–10 in.) above the ground; the float indicator should be at **0**.
4. Loosen sensor-mounting nuts (A).
5. Check that the left sensor is at the correct high voltage limit.
6. Rotate sensor (B) counterclockwise to lower the voltage. Rotate sensor clockwise to raise the voltage.
7. Tighten sensor-mounting nuts (A).

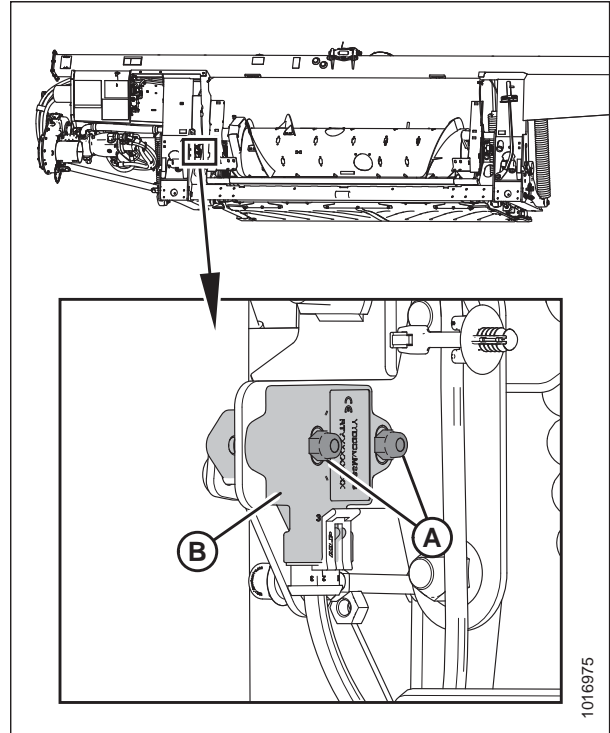

Figure 4.9: Optional Two-Sensor Kit – Left Sensor

Follow these steps to adjust the right sensor voltage:

8. Extend guard angle fully; the header angle indicator should be at **D**.
9. Position header 150–254 mm (6–10 in.) above the ground; the float indicator should be at **0**.

TROUBLESHOOTING

10. Loosen sensor mounting nuts (A).
11. Rotate sensor (B) clockwise to lower the voltage. Rotate sensor counterclockwise to raise the voltage.
12. Check that the right sensor is at the correct high voltage limit.
13. Tighten sensor mounting nuts (A).

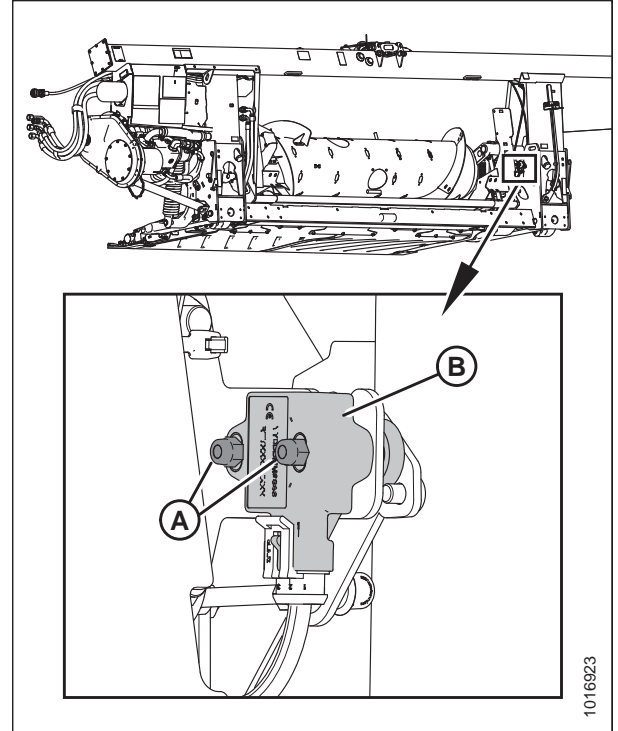

Figure 4.10: Optional Two-Sensor Kit – Right Sensor

14. Fully lower the header; float indicator (A) should be at 4.
15. Check that both sensors are at the correct low voltage limit.

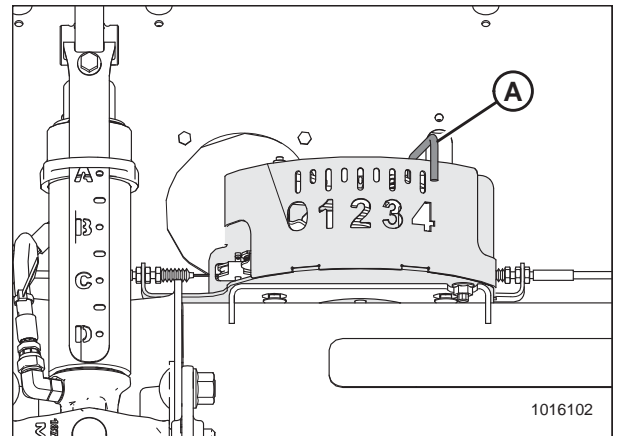

Figure 4.11: Float Indicator Box

4.3 Sensor Output Voltage Range – Combine Requirements

The auto header height control (AHHC) sensor output must be within a specific voltage range for each combine, or the AHHC feature will not work properly.

Table 4.1 Combine Voltage Limits

Combine	Low Voltage Limit	High Voltage Limit	Range (Difference between High and Low Limits)
AGCO IDEAL™ Series	0.5 V	4.5 V	2.5 V
Case IH 5088/6088/7088, 5130/6130/7130, 7010/8010, 7120/8120/9120, 7230/8230/9230, and 7240/8240/9240	0.5 V	4.5 V	2.5 V
Case IH 2588/2577	2.8 V	7.2 V	4.0 V
Challenger, Gleaner A, Massey Ferguson, and IDEAL Series	0.5 V	4.5 V	2.5 V
CLAAS 500/600/700 Series	0.5 V	4.5 V	2.5 V
Gleaner R and S Series	0.5 V	4.5 V	2.5 V
John Deere 60, 70, S, and T Series	0.5 V	4.5 V	2.5 V
New Holland CR/CX - 5 V system	0.7 V	4.3 V	2.5 V
New Holland CR/CX - 10 V system	2.8 V	7.2 V	4.1–4.4 V
<p>NOTE: Some combine models do not support checking sensor output voltage from the cab (early Case 23/2588 series, CLAAS 500/600/700 Series). For these models, check output voltage manually. Refer to or 4.1 Manually Checking Voltage Range – Two-Sensor System, page 17.</p>			

MacDon Industries Ltd.

680 Moray Street
Winnipeg, Manitoba
Canada R3J 3S3
t. (204) 885-5590 f. (204) 832-7749

MacDon, Inc.

10708 N. Pomona Avenue
Kansas City, Missouri
United States 64153-1924
t. (816) 891-7313 f. (816) 891-7323

MacDon Australia Pty. Ltd.

A.C.N. 079 393 721
P.O. Box 103 Somerton, Victoria, Australia
Australia 3061
t.+61 3 8301 1911 f.+61 3 8301 1912

MacDon Brasil Agribusiness Ltda.

Rua Grã Nicco, 113, sala 404, B. 04
Mossunguê, Curitiba, Paraná
CEP 81200-200 Brasil
t. +55 (41) 2101-1713 f. +55 (41) 2101-1699

LLC MacDon Russia Ltd.

123317 Moscow, Russia
10 Presnenskaya nab, Block C
Floor 5, Office No. 534, Regus Business Centre
t. +7 495 775 6971 f. +7 495 967 7600

MacDon Europe GmbH

Hagenauer Strasse 59
65203 Wiesbaden
Germany

CUSTOMERS

MacDon.com

DEALERS

Portal.MacDon.com

Trademarks of products are the marks of their
respective manufacturers and/or distributors.

Printed in Canada