

9000 Series Self-Propelled Windrowers MUFFLER KIT (MD #167916) INSTALLATION INSTRUCTIONS

This muffler kit supersedes muffler MD #111089 on turbocharged Cummins engines for 9000 Series Self-Propelled Windrowers. As built, windrowers with turbocharged Cummins engines had muffler MD #111089 installed. MD #111089 has been discontinued and MD #167916 will be used to service orders for MD #111089. MD #167916 has similar noise characteristics with increased engine performance.

A list of parts included in the kit is provided.

Installation Time

Approximate installation time for this kit is 30 minutes.

Conventions

The following conventions are followed in this document:

- Front and rear are determined from the operator's position, with the header at the front of the windrower and the engine to the rear.
- Unless otherwise noted, use the standard torque values provided in the windrower operator's manual and technical manual.

**9000 Series Self-Propelled Windrowers
MUFFLER KIT (MD #167916)
INSTALLATION INSTRUCTIONS**

Part List

This kit includes the following parts:

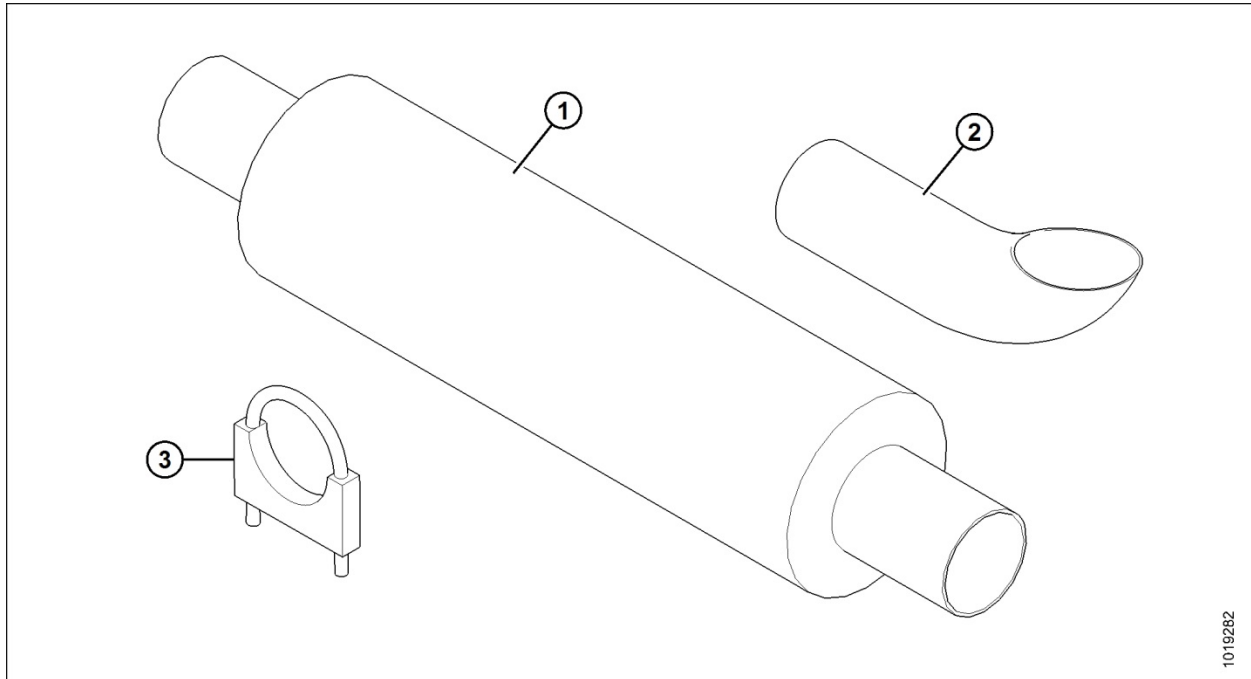

Figure 1: Muffler Kit Parts

Ref	Part Number	Description	Quantity
1	167915	MUFFLER – TURBO	1
2	167893	MUFFLER – TURNDOWN TIP	1
3	42469	CLAMP – PIPE	1

9000 Series Self-Propelled Windrowers MUFFLER KIT (MD #167916) INSTALLATION INSTRUCTIONS

Installation Instructions

To install the muffler kit, follow these steps:



DANGER

To avoid bodily injury or death from unexpected start-up of machine, always stop engine and remove key from ignition before leaving operator's seat for any reason.



CAUTION

To avoid burns, do not touch muffler when engine is running. Allow sufficient cooling time after shut-down.

1. Ensure engine is off and muffler (A) is not hot to the touch.
2. Open hood. For instructions, refer to the windrower operator's or technical manual.
3. Loosen or remove the muffler clamp at the base of the muffler.
4. Remove the muffler from the engine.
5. Install new muffler (MD #167915) onto engine.

NOTE: Ensure the muffler end marked "INLET" is connected to the elbow on the turbo.

6. Place the turndown tip (MD #167893) into the outlet end of the muffler. Position tip outlet to face rearward.
7. Install muffler clamp (MD #42469) onto connection between muffler outlet and turndown tip. Clamp should be positioned such that it is below the slots cut into the muffler outlet.

8. Close hood. For instructions, refer to the windrower operator's or technical manual.



Figure 2: Existing Muffler