

R85
**16-Foot Rotary Disc Self-Propelled
Windrower Header and Pull-Type
Mower Conditioner**

Bevel Gearbox Kit (MD #268040) Installation Instructions

147974 Revision B

Original Instruction

R85 16-Foot Rotary Disc Self-Propelled Windrower Header and Pull-Type Mower Conditioner



1002166

Introduction

The Bevel Gearbox kit (MD #268040) is used to replace the cutterbar drive gearbox (also known as the bevel gearbox) on R85 16-Foot Rotary Disc Self-Propelled Windrower Headers and Pull-Type Mower Conditioners built in model year 2015 or earlier. The new gearbox is factory-installed on headers built in model year 2016 and later.

This document explains how to install the kit. A list of parts included in the kit is provided in Chapter [2 Parts List, page 5](#).

Installation Time

Installation time for this kit is approximately 3-1/2 hours.

Conventions

The following conventions are used in this document:

- Right-hand (RH) and left-hand (LH) are determined from the operator's position. The front of the header/mower conditioner is the side that faces the crop.
- Unless otherwise noted, use the standard torque values provided in the header operator's manual and technical manual.

NOTE:

Keep your MacDon publications up-to-date. The most current version of this instruction can be downloaded from our Dealer-only site (<https://portal.macdon.com>) (login required).

NOTE:

This document is not currently available in any language except English.

List of Revisions

At MacDon, we're continuously making improvements, and occasionally these improvements affect product documentation. The following list provides an account of major changes from the previous version (MD #147974 revision A) of this document.

Summary of Change	Location
Revised installation time.	Introduction, page i
Changed oil quantity.	3.9 Adding Oil to Cutterbar Drive Gearbox, page 25

TABLE OF CONTENTS

Introduction	i
List of Revisions	ii
1 Safety	1
1.1 Signal Words.....	1
1.2 General Safety	2
2 Parts List.....	5
3 Installation Instructions	9
3.1 Removing Hazard Light.....	9
3.2 Removing Header Drive Motor.....	10
3.3 Opening the Driveshield	11
3.3.1 Opening the Driveshield North American	11
3.3.2 Opening the Driveshield Export	12
3.4 Removing Existing Cutterbar Drive Gearbox.....	13
3.5 Removing Left-Hand Endshield and Frame Channel	17
3.6 Installing New Cutterbar Drive Gearbox.....	18
3.7 Reinstalling Left-Hand Endshield and Frame Channel.....	23
3.8 Reinstalling Header Drive Motor	24
3.9 Adding Oil to Cutterbar Drive Gearbox	25
3.10 Closing the Driveshield	26
3.10.1 Closing the Driveshield North American	26
3.10.2 Closing the Driveshield Export	27
3.11 Closing Cutterbar Doors.....	28
3.11.1 Closing the Cutterbar Doors: North American Header or Mower Conditioner.....	28
3.11.2 Closing the Cutterbar Doors: Export Header or Mower Conditioner	30
3.12 Replacing Left-Hand Hazard Light	33

1 Safety

1.1 Signal Words

Three signal words, **DANGER**, **WARNING**, and **CAUTION**, are used to alert you to hazardous situations. The appropriate signal word for each situation has been selected using the following guidelines:

DANGER

Indicates an imminently hazardous situation that, if not avoided, will result in death or serious injury.

WARNING

Indicates a potentially hazardous situation that, if not avoided, could result in death or serious injury. It may also be used to alert against unsafe practices.

CAUTION

Indicates a potentially hazardous situation that, if not avoided, may result in minor or moderate injury. It may be used to alert against unsafe practices.

1.2 General Safety

CAUTION

The following are general farm safety precautions that should be part of your operating procedure for all types of machinery.

Protect yourself.

- When assembling, operating, and servicing machinery, wear all protective clothing and personal safety devices that could be necessary for job at hand. Do **NOT** take chances. You may need the following:
 - Hard hat
 - Protective footwear with slip resistant soles
 - Protective glasses or goggles
 - Heavy gloves
 - Wet weather gear
 - Respirator or filter mask
- Be aware that exposure to loud noises can cause hearing impairment or loss. Wear suitable hearing protection devices such as ear muffs or ear plugs to help protect against objectionable or loud noises.

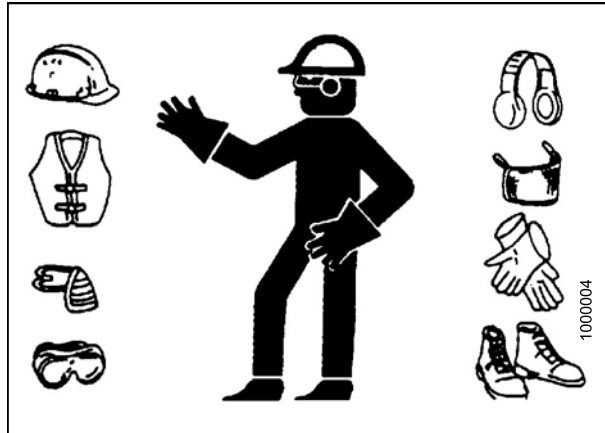

Figure 1.1: Safety Equipment



Figure 1.2: Safety Equipment

- Provide a first aid kit for use in case of emergencies.
- Keep a fire extinguisher on the machine. Be sure fire extinguisher is properly maintained. Be familiar with its proper use.
- Keep young children away from machinery at all times.
- Be aware that accidents often happen when Operator is tired or in a hurry. Take time to consider safest way. Never ignore warning signs of fatigue.

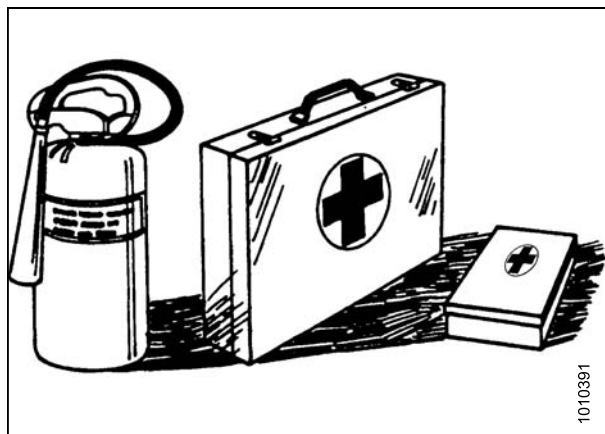

Figure 1.3: Safety Equipment

SAFETY

- Wear close-fitting clothing and cover long hair. Never wear dangling items such as scarves or bracelets.
- Keep all shields in place. **NEVER** alter or remove safety equipment. Make sure driveline guards can rotate independently of shaft and can telescope freely.
- Use only service and repair parts made or approved by equipment manufacturer. Substituted parts may not meet strength, design, or safety requirements.



Figure 1.4: Safety around Equipment

- Keep hands, feet, clothing, and hair away from moving parts. **NEVER** attempt to clear obstructions or objects from a machine while engine is running.
- Do **NOT** modify machine. Unauthorized modifications may impair machine function and/or safety. It may also shorten machine's life.
- To avoid bodily injury or death from unexpected startup of machine, **ALWAYS** stop engine and remove key from ignition before leaving operator's seat for any reason.

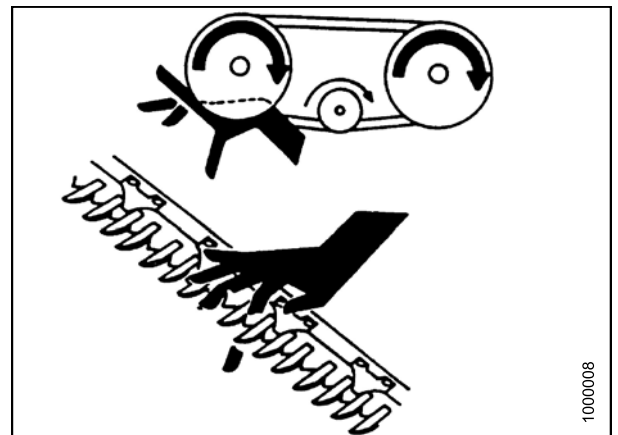

Figure 1.5: Safety around Equipment

- Keep service area clean and dry. Wet or oily floors are slippery. Wet spots can be dangerous when working with electrical equipment. Be sure all electrical outlets and tools are properly grounded.
- Keep work area well lit.
- Keep machinery clean. Straw and chaff on a hot engine is a fire hazard. Do **NOT** allow oil or grease to accumulate on service platforms, ladders, or controls. Clean machines before storage.
- **NEVER** use gasoline, naphtha, or any volatile material for cleaning purposes. These materials may be toxic and/or flammable.
- When storing machinery, cover sharp or extending components to prevent injury from accidental contact.



Figure 1.6: Safety around Equipment

2 Parts List

The following parts are included in this kit.

PARTS LIST

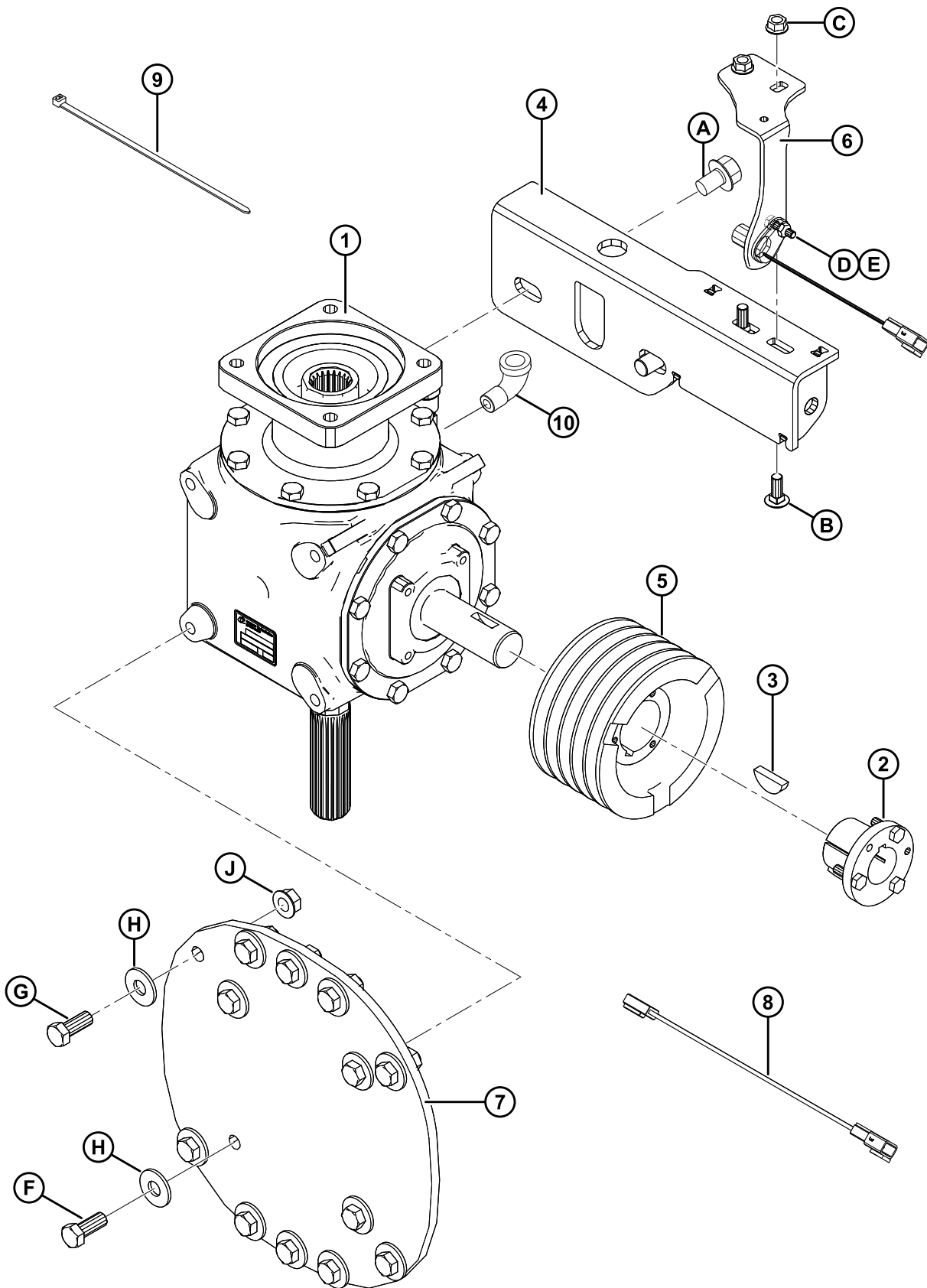

Figure 2.1: Parts Included in R85 Cutterbar Drive Gearbox Kit

PARTS LIST

Ref	Part Number	Description	Quantity
1	236983	DRIVE GEARBOX – 90 DEG	1
2	115074	BUSHING – SPLIT TAPER	1
3	11142	KEY – WOODRUFF (5/16 X 1 1/8 NOM)	1
4	268122	IDLER BRACKET	1
5	268129	PULLEY	1
6	268023	BRACKET – SPEED SENSOR	1
7	236985	GEARBOX PLATE	1
8	268049	HARNESS – WIRING SP EXTENSION	1
9	30753	FASTENER – CABLE TIE, BLACK	1
10	5735	FITTING – 90° STREET ELBOW - 3/8 NPT	1
A	105066	BOLT – HH FLG (SERR FACE) 1/2 - NC X 3/4 IN. LG GR 5 ZP	2
B	19965	BOLT – RHSN 3/8-16 X 1 GR5 ZP	2
C	30228	NUT – FLANGE DT SMOOTH FACE 0.375–16UNC	2
D	21573	BOLT – HEX HD 1/4 NC X 1.0 LG FR 5 ZP	1
E	18724	NUT – HEX LOCK DT 1/4-20 UNC ZP	1
F	136067	BOLT – HH 1/2 NC X 1.25 LG GR 8 ZP	4
G	21491	BOLT – HH 1/2 NC X 1.25 LG GR 5 ZP	10
H	137699	WASHER – USS HARDENED FLAT, 1/2 NOM. ID	14
J	50186	NUT – FLANGE LOCK SMOOTH FACE DT 0.500–13UNC GR 5	10

3 Installation Instructions

To install the Bevel Gearbox kit, follow these steps:

CAUTION

To avoid bodily injury or death from unexpected startup of machine, always stop engine and remove key from ignition before leaving operator's seat for any reason.

1. Lower the header/mower conditioner fully.
2. Shut down the engine and remove the key.

3.1 Removing Hazard Light

The left-hand hazard light and lamp bracket must be removed before the new gearbox can be installed. To remove them, follow these steps:

1. Disconnect lamp wires from wiring harness at connectors (A).
2. Remove four bolts (B) and remove lamp assembly (C) from header/mower conditioner. Retain bolts and lamp assembly for reinstallation.

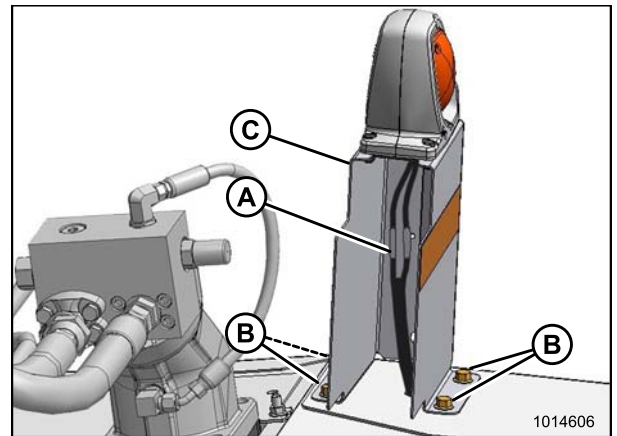

Figure 3.1: Hazard Light

INSTALLATION INSTRUCTIONS

3.2 Removing Header Drive Motor

To remove the header drive motor, follow these steps:

1. Loosen the access panel bolts and remove panel (A). Retain for reinstallation.
2. Remove the four bolts (B) securing the header drive motor (C) to the gearbox.
3. Remove the motor.

IMPORTANT:

Do NOT lift motor by the hydraulic lines. The motor weighs approximately 68 kg (150 lb.). Use a sling or chain and hoist to lift.

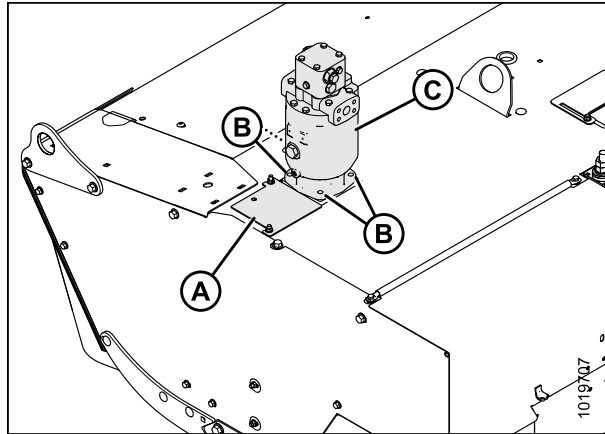

Figure 3.2: Motor

3.3 Opening the Driveshield

The procedure for opening the driveshield varies depending on whether the header or mower conditioner was sold in North America or not.

Refer to the relevant procedure:

- [3.3.1 Opening the Driveshield North American , page 11](#)
- [3.3.2 Opening the Driveshield Export , page 12](#)

3.3.1 Opening the Driveshield North American

Follow these steps to open the driveshield on North American mowers/headers:

1. Release rubber latches (A).
2. Lift shield (B).

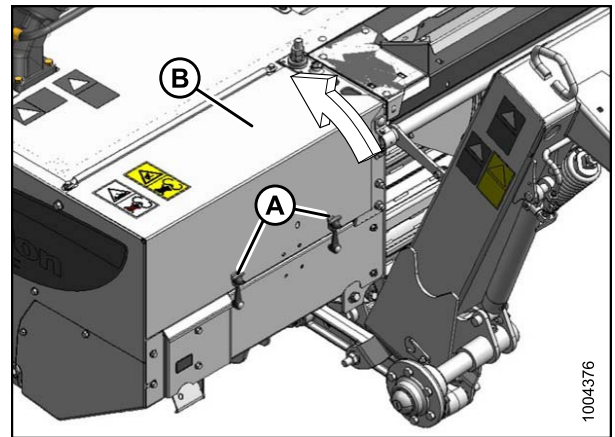

Figure 3.3: Driveshield: 16-Ft. Pull Type

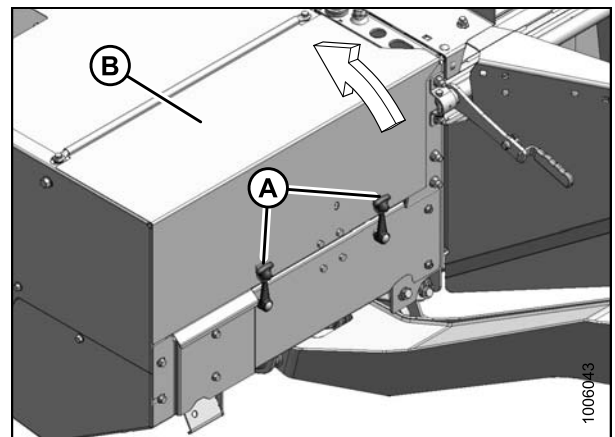

Figure 3.4: Driveshield: 16-Ft. SP Header

INSTALLATION INSTRUCTIONS

3.3.2 Opening the Driveshield Export

Follow these steps to open the driveshield on export mowers/headers:

1. Release rubber latches (A).
2. Insert a screwdriver (or equivalent) through hole in shield (B) and into the notch in latch (C) and disengage latch.
3. Open driveshield (D).

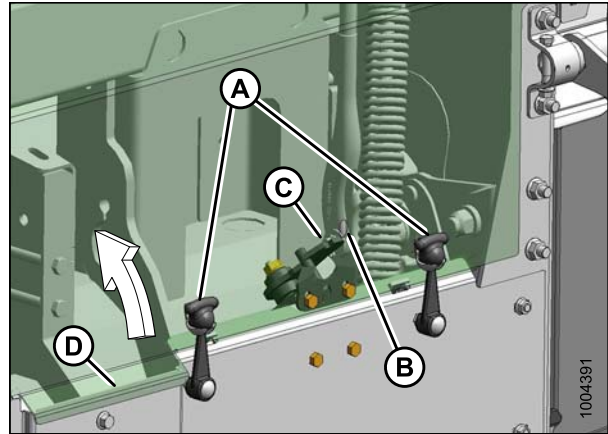

Figure 3.5: Driveshield

INSTALLATION INSTRUCTIONS

3.4 Removing Existing Cutterbar Drive Gearbox

The existing cutterbar drive gearbox is located below the header drive motor. To remove the existing gearbox, follow these steps:

1. Loosen jam nut (A) and adjust nut (B) until belt tension is released fully.

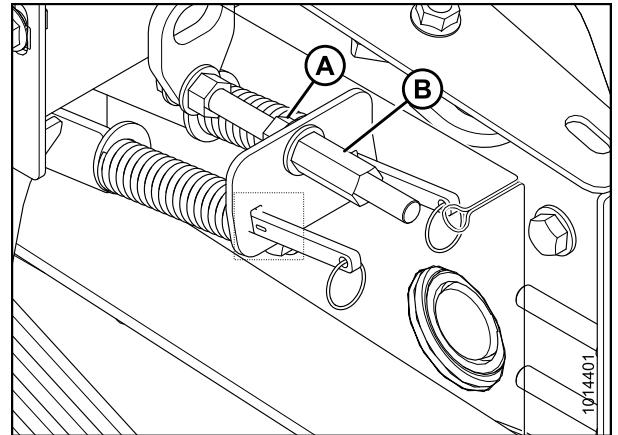

Figure 3.6: Belt Tension/Speed Sensor Assembly

2. Slide the belts (A) off the gearbox pulley.

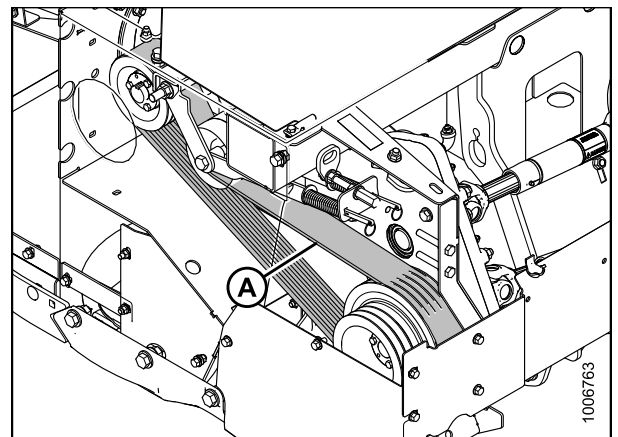

Figure 3.7: Belts

3. Remove bolts (A) from the belt tensioner / speed sensor assembly (B), and detach assembly from gearbox. Discard the idler and speed sensor brackets (C) and (D) and the bolts (A). To prevent the belt tensioner / speed sensor assembly from interfering with the removal of the gearbox, tie the other components in the assembly back out of the way.

NOTE:

There is no speed sensor on the pull-type mower conditioner.

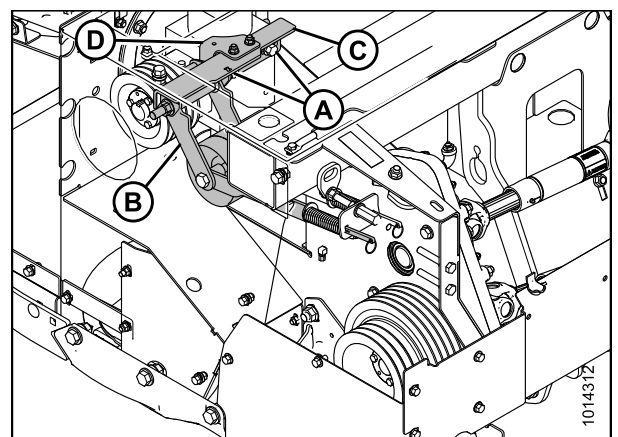

Figure 3.8: Belt Tensioner/Speed Sensor Assembly

INSTALLATION INSTRUCTIONS

4. Unhook the curtain latches (A) on the left side of the header/mower conditioner.

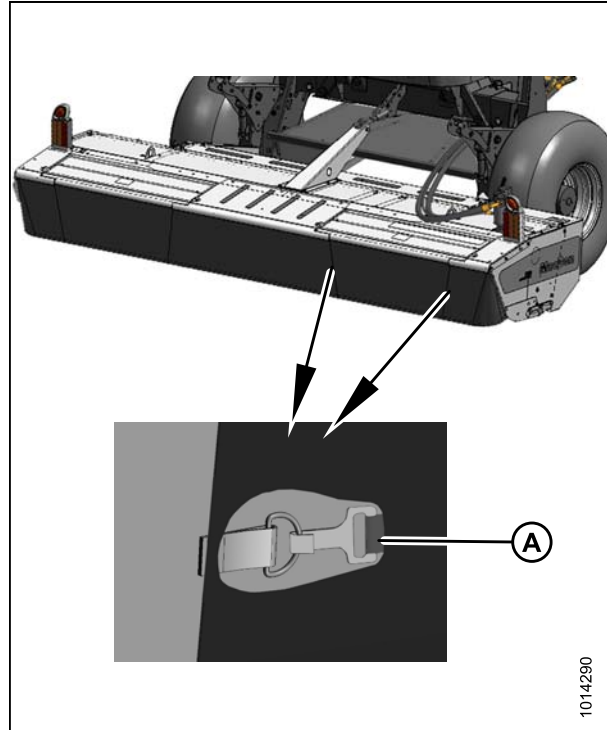

Figure 3.9: Curtain Latches

5. **North American headers/mower conditioners:** Lift the front of the left-hand cutterbar door to the open position.



Figure 3.10: Cutterbar Doors Open

INSTALLATION INSTRUCTIONS

6. **For export headers/mower conditioners:** Insert a screwdriver (or equivalent) through hole (A) in door into notch in latch (B) and push latch to disengage.
7. Lift the front of the left-hand cutterbar door to the open position.

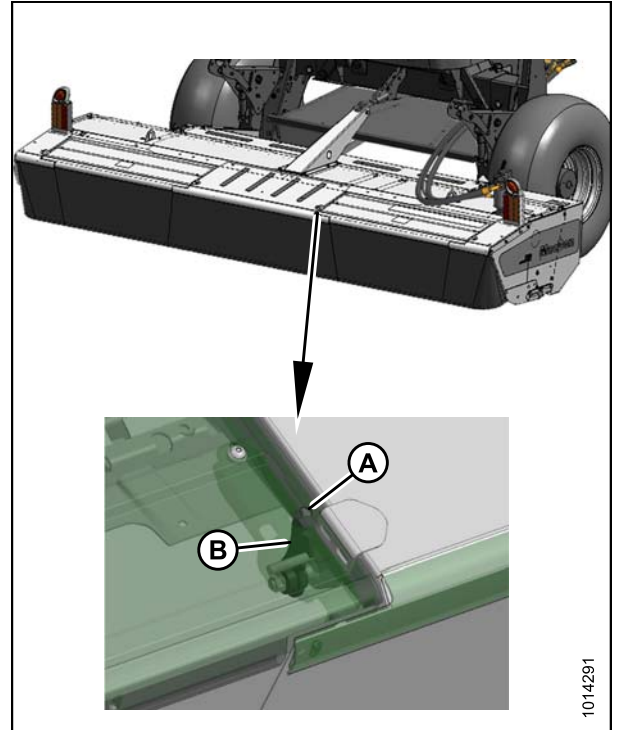

Figure 3.11: Cutterbar Door Latch on Export Header

8. Remove the ten bolts (A) that hold the gearbox plate (B) to the frame.

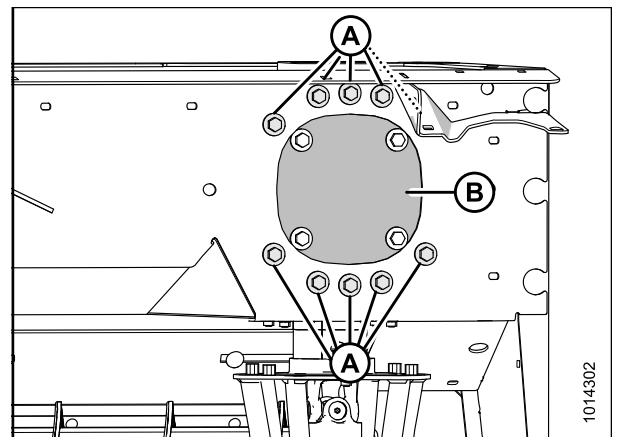

Figure 3.12: Gearbox Mounting Bolts

INSTALLATION INSTRUCTIONS

- Using a suitable lifting device, lift the gearbox, gearbox plate, and pulley out of the header.

IMPORTANT:

Use an appropriate lifting device. The gearbox weighs approximately 68 kg (150 lb.).

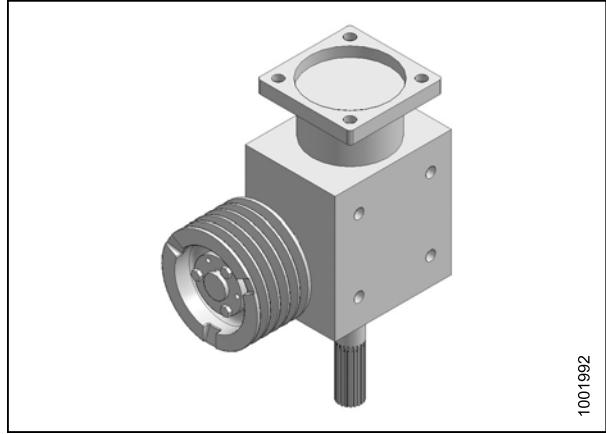

Figure 3.13: Gearbox and Pulley

INSTALLATION INSTRUCTIONS

3.5 Removing Left-Hand Endshield and Frame Channel

The new gearbox will not fit through the access panel in the top cover of the header/mower conditioner, so the top cover must be lifted or removed. In order to do that, the left-hand endshield and frame channel must be removed. To remove them, follow these steps:

NOTE:

This procedure assumes that the left-hand cutterbar door is still open from the previous procedure.

1. Remove the bolts (A) and nuts attaching the hook (B) and the divider support (C) to the left-hand endshield (D). Retain hook, divider support, and hardware for reinstallation.
2. Remove the bolts (E) and nuts attaching the left-hand endshield (D) to the header/mower conditioner, and then remove the endshield. Retain the endshield and hardware for reinstallation.
3. Remove the left-hand frame channel (A) and corner shield (B). Retain for reinstallation.

NOTE:

Some parts removed from illustration for clarity.

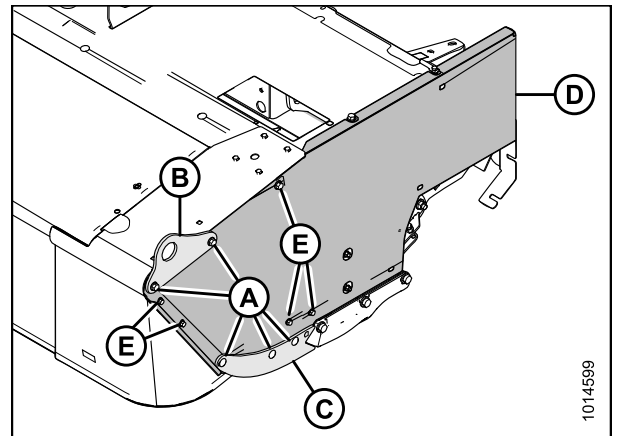

Figure 3.14: LH Endshield

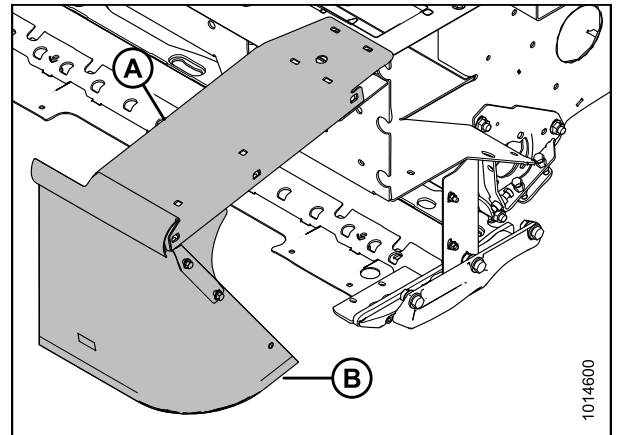

Figure 3.15: LH Front Corner of Header/Mower Conditioner

INSTALLATION INSTRUCTIONS

3.6 Installing New Cutterbar Drive Gearbox

To install the new gearbox (MD #236983) provided in the kit, follow these steps:

1. Attach gearbox mounting plate (A) (MD #236985) to frame with ten each of the following:
 - 1.25 in. long grade 5 hex head bolts (MD #21491)
 - USS hardened flat washers (B) (MD #137699)
 - Flange lock nuts (MD #50186)

Mounting plate, bolts, washers, and nuts are all provided in kit.

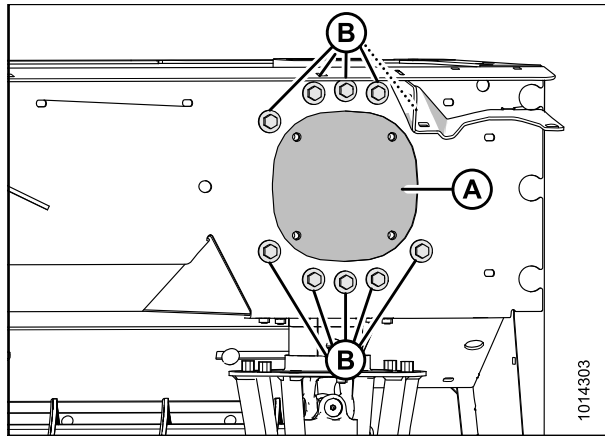

Figure 3.16: Gearbox Mounting Plate and Hardware

2. Lift the left-hand end of the top cover and hold it up.

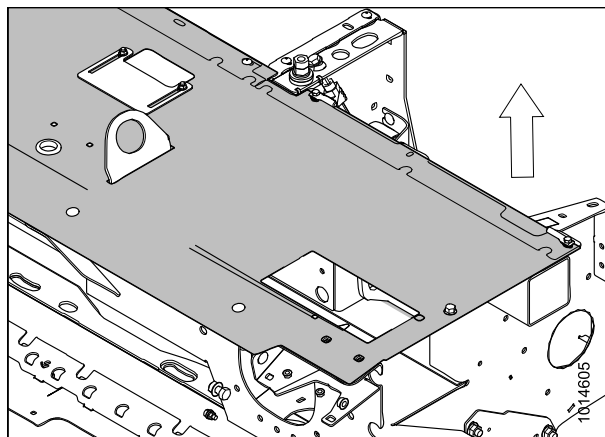

Figure 3.17: LH End of Top Cover

3. Position new gearbox (A) (MD #236983) inside the frame against the gearbox mounting plate (B) as shown at right.

IMPORTANT:

Use an appropriate lifting device. The gearbox weighs approximately 68 kg (150 lb.).

NOTE:

Left-hand frame member and top cover removed from illustration for clarity.

4. Lower top cover.

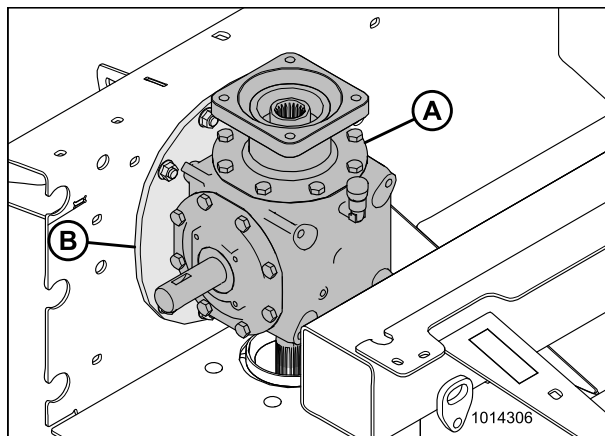

Figure 3.18: Gearbox Position

INSTALLATION INSTRUCTIONS

- Attach gearbox to the mounting plate (A) with four 1-1/4 in. long grade 8 hex head bolts (MD #136067) and USS hardened flat washers (B) (MD #137699). Use Loctite® 262 on the threads. Torque bolts to 87 N·m (64 ft·lbf). Bolts and washers are all provided in kit.

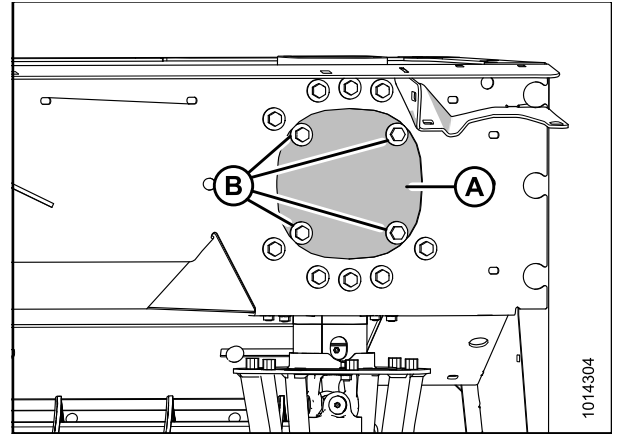

Figure 3.19: Gearbox Mounting Hardware

- On opposite side of gearbox from the mounting plate, attach idler bracket (A) (MD #268122) to the gearbox (B) with two 3/4 in. long hex head flange bolts (C) (MD #105066). Bracket and bolts are provided in the kit.

NOTE:

Top cover removed from illustration for clarity.

- If gearbox elbow fitting (D) is touching idler bracket (A), remove the elbow fitting and replace with elbow fitting (MD #5735). Detach breather from old elbow and reinstall on new one. The new elbow fitting is provided in the kit.
- Insert Woodruff key (B) (MD #11142) into gearbox shaft (A). Woodruff key is provided in kit.

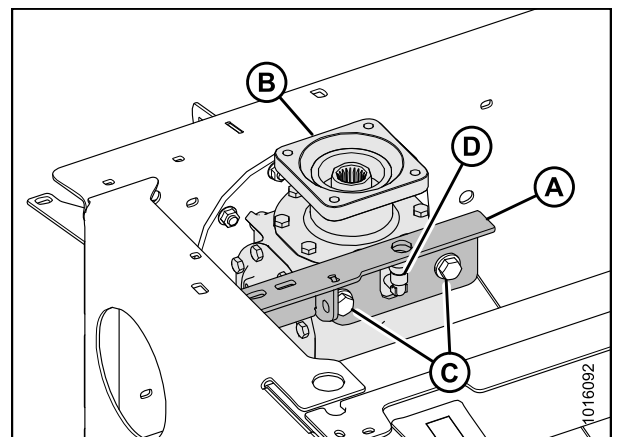

Figure 3.20: Gearbox and Idler Bracket Installed

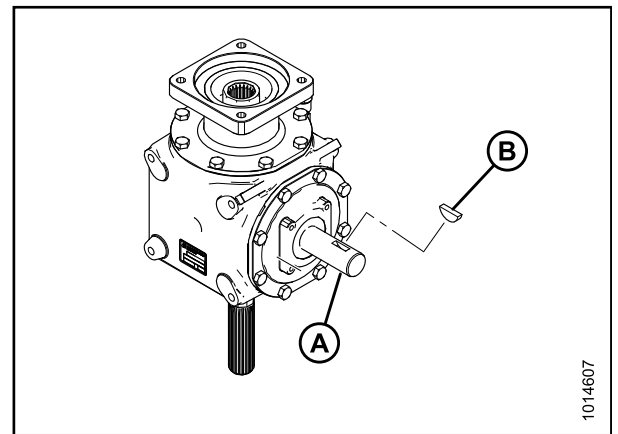

Figure 3.21: Gearbox and Woodruff Key

INSTALLATION INSTRUCTIONS

- Slide pulley (B) (MD #268129) onto gearbox shaft (A) with notches facing outboard. The pulley is provided in the kit.
- Slide split taper bushing (C) (MD #115074) onto gearbox shaft (A). The bushing is provided in the kit.

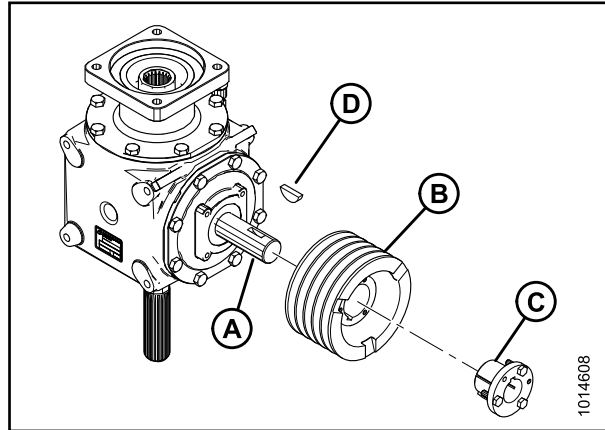

Figure 3.22: Gearbox Components

A - Gearbox Shaft
B - Pulley
C - Split Taper Bushing
D - Woodruff Key

- Measure the distance (C) from the outer face of the pulley (B) to the edge of the gearbox. It should be 102.6 mm (4-1/16 in.).

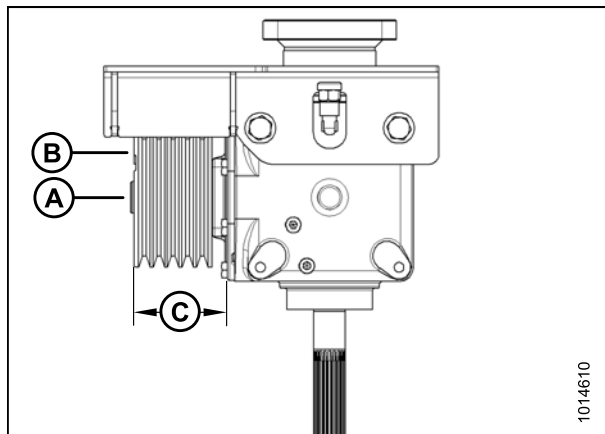

Figure 3.23: Pulley Positioning

A - Gearbox Shaft
B - Pulley
C - 102.6 mm (4-1/16 in.)

- Using a straight edge, ensure cutterbar drive gearbox pulley (A) is aligned within 2 mm (1/16 in.) of the conditioner pulley (B). If there is any misalignment, adjust the position of the pulley (B).

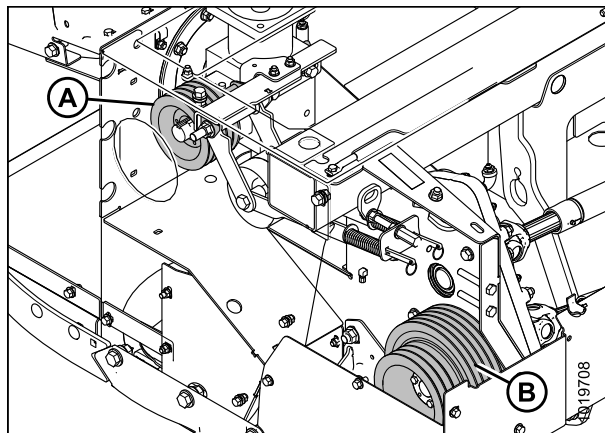

Figure 3.24: Pulleys

INSTALLATION INSTRUCTIONS

13. **Windrower headers only:** Attach speed sensor bracket (A) (MD #268122) to idler bracket (B) with two 1 in. carriage bolts (MD #19965) and two flange nuts (C) (MD #30228). Speed sensor bracket, bolts, and nuts are provided in kit.
14. **Windrower headers only:** Reinstall speed sender (D). Adjust sensor so that the gap between the sensor and the pulley is 2–3 mm (1/16–1/8 in.).

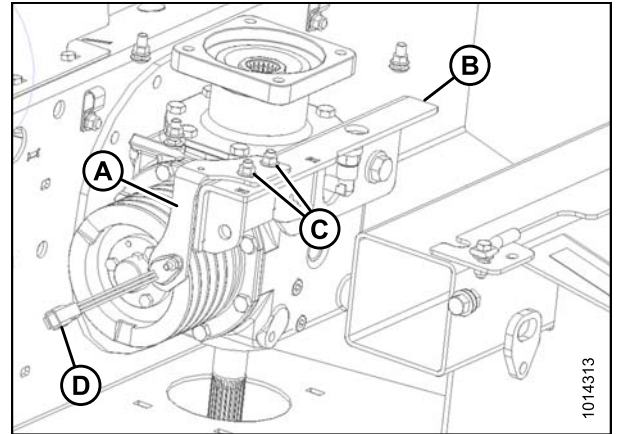

Figure 3.25: Speed Sensor Bracket and Speed Sender Installed on Windrower Header

15. Reattach the tensioner/speed sensor components (A) tied back in Step 3, page 13.

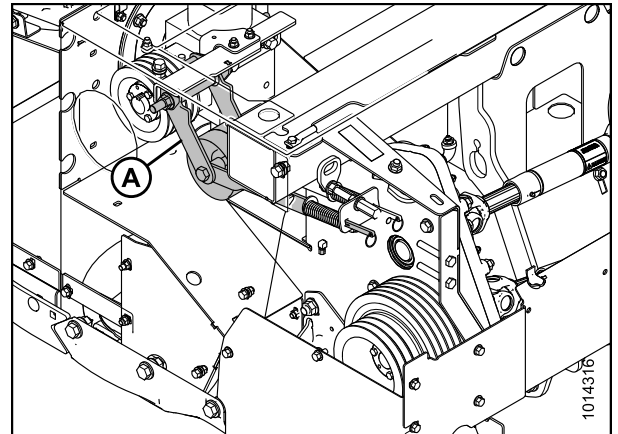

Figure 3.26: Tensioner/Speed Sensor Assembly

16. Reinstall the belts (A) onto the gearbox pulley.
17. **Windrower headers only:** Using feeler gauges, set a clearance of 2 mm (0.08 in.) between the sensor and the pulley.

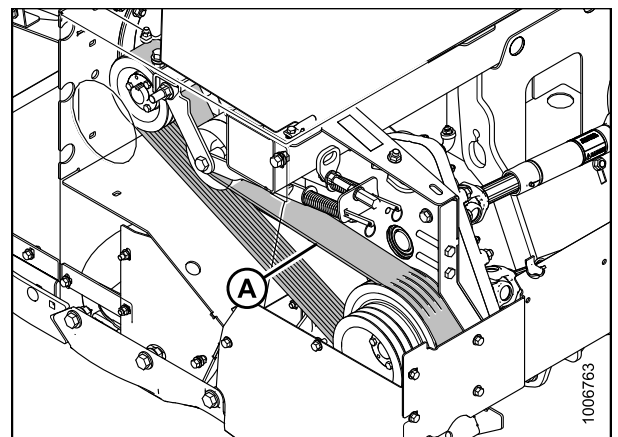

Figure 3.27: Belts

INSTALLATION INSTRUCTIONS

18. Adjust nut (B) to tension the gearbox drive belt. Tension the belt until plate (C) is just past the slot (D).
19. Lock jam nut (A).

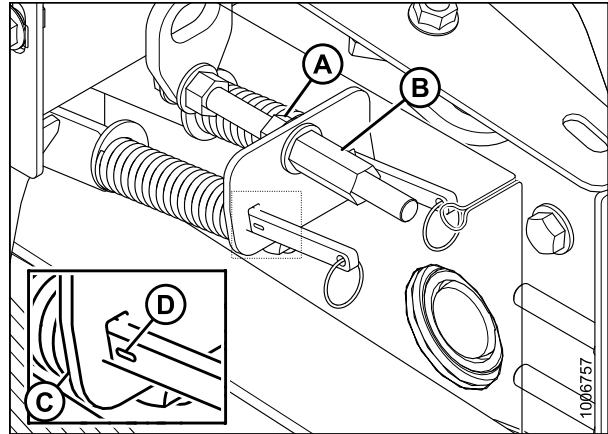

Figure 3.28: Belt Tensioner

20. **Windrower headers only:** Attach the speed sender to the P88A branch of the main wiring harness (A).

- **For model year 2015,** route the P88A branch (B) around the flange of the gearbox, and then down through the hole (C) in the top of the speed sensor bracket. If the harness cannot reach the speed sender, connect harness extension (MD #268049). Secure any excess harness to the main wiring harness with a cable tie (MD #30753). The harness extension and cable tie are provided in the kit.
- **For model years 2014 and earlier,** route the P88A branch along the side of the frame, and then down through the hole in the top of the speed sensor bracket. Secure any excess harness with a cable tie (MD #30753) to keep it away from the belt. The cable tie is provided in the kit.

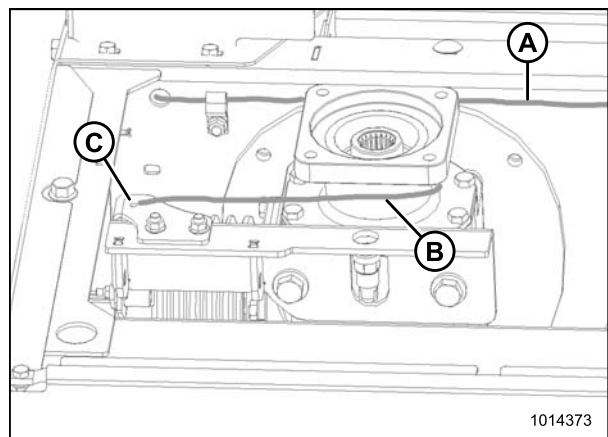

Figure 3.29: P88A Harness Branch Routing – Model Year 2015

INSTALLATION INSTRUCTIONS

3.7 Reinstalling Left-Hand Endshield and Frame Channel

To reinstall the left-hand endshield and frame channel, follow these steps. Unless damaged, reuse the original hardware. Replacements are not included in the kit.

1. Position left-hand frame channel (A) over front edge of top cover with left-hand corner shield (B) hanging down.

NOTE:

Some parts were removed from the illustration for clarity.

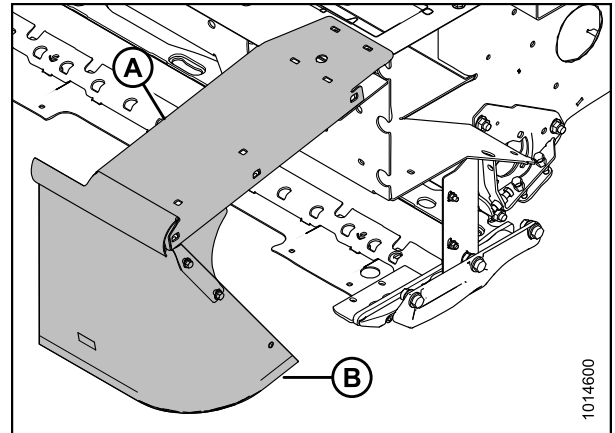

Figure 3.30: LH Front Corner of Header/Mower Conditioner

2. Position left-hand endshield (A) with top edge over the left-hand edge of the top cover. Fasten in place with the following hardware retained from disassembly:
 - One 1-1/4 in. long hex head bolt and a flange lock nut at location (B)
 - Two 3/4 in. long hex head flange bolts and distorted thread flange nuts at location (C)
 - Two 1 in. long hex head flange bolts at location (D)

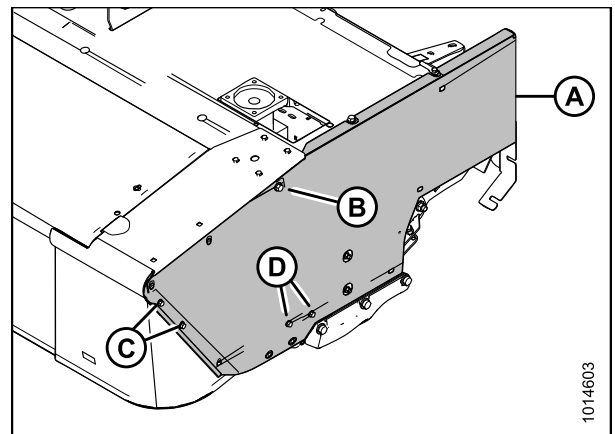

Figure 3.31: LH Endshield

3. Reattach hook (A) to endshield with two 1-1/4 in. long hex head bolts and flange lock nuts at location (B).
4. Reattach divider support (C) to endshield with two 1-1/4 in. long carriage bolts and flange lock nuts at location (D) and one 1-1/2 in. long carriage bolt and flange lock nut at location (E).

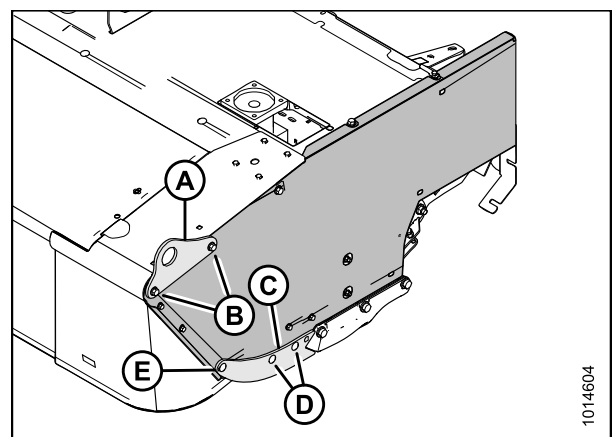

Figure 3.32: LH Endshield

INSTALLATION INSTRUCTIONS

3.8 Reinstalling Header Drive Motor

To reinstall the header drive motor, follow these steps:

IMPORTANT:

Do NOT lift motor by the hydraulic lines. The motor weighs approximately 68 kg (150 lb.). Use a sling or chain and hoist to lift.

1. Reinstall motor (C) onto the gearbox and secure with four bolts (B). Torque to 140 N·m (103 ft·lbf).
2. Install the access panel (A) and secure with bolts.

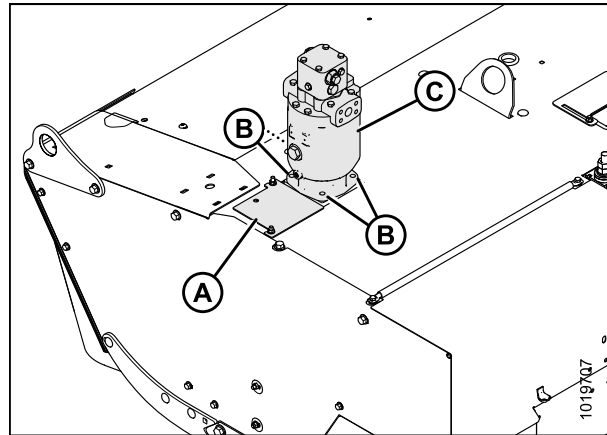

Figure 3.33: Motor

3.9 Adding Oil to Cutterbar Drive Gearbox

⚠ CAUTION

To avoid bodily injury or death from unexpected startup of machine, always stop engine and remove key from ignition before leaving operator's seat for any reason.

1. Position header/mower conditioner so that the gearbox is level with the ground. Stop the engine, and remove the key.
2. If you have a squeeze bottle for your oil, remove plug (A). If you don't, then leave plug (A) in place.
3. Remove breather from filler elbow (B).
4. If you have a squeeze bottle for the oil, through port (A) add 2.1 L (2.2 quarts) of 75W-90 synthetic gear lubricant with high thermal and oxidation stability conforming to API GL-5 minimum (SAE J2360 preferred) specifications such as Traxon E Synthetic 75W-90 gear oil. Lubricant should slightly run out of port (A) when at the proper level.
5. If you don't have a squeeze bottle, use a funnel in filler elbow (B) to add 2.1 L (2.2 quarts) of 75W-90 synthetic gear lubricant with high thermal and oxidation stability conforming to API GL-5 minimum (SAE J2360 preferred) specifications such as Traxon E Synthetic 75W-90 gear oil.
6. Reinstall plug (A) and breather (B). Tighten.

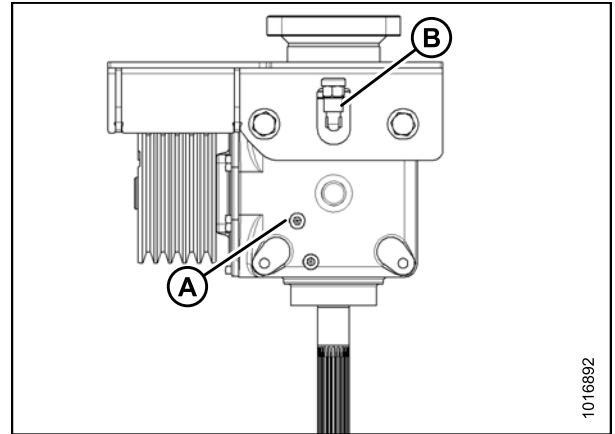

Figure 3.34: Cutterbar Drive Gearbox

3.10 Closing the Driveshield

The procedure for closing the driveshield varies depending on whether the header or mower conditioner was sold in North America or not.

Follow the relevant procedure:

- [3.10.1 Closing the Driveshield North American , page 26](#)
- [3.10.2 Closing the Driveshield Export , page 27](#)

3.10.1 Closing the Driveshield North American

Follow these steps to close the driveshield on North American mowers/headers:

1. Lower shield (B) so that pins at lower end of shield engage holes in lower panel.
2. Engage rubber latches (A).

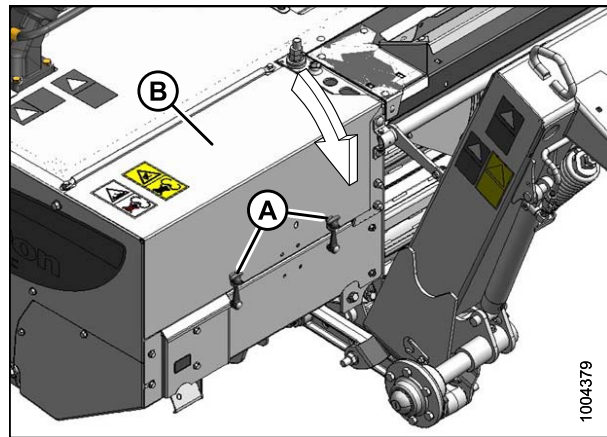

Figure 3.35: Driveshield: 16-ft Pull-Type

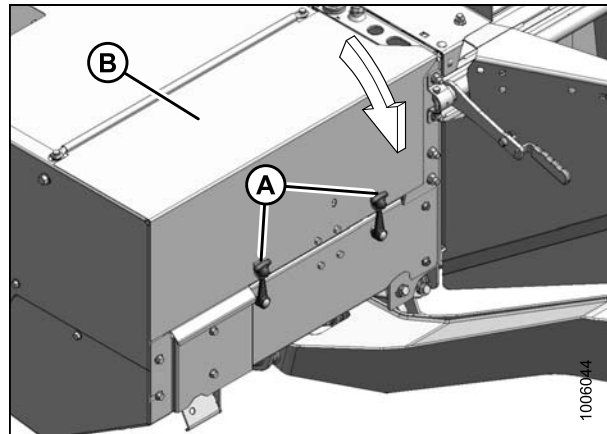

Figure 3.36: Driveshield: 16-Ft. SP Header

INSTALLATION INSTRUCTIONS

3.10.2 Closing the Driveshield Export

Follow these steps to close the driveshield on export mowers/headers:

1. Lower the shield (C) so that pins at lower end of shield engage holes in the lower panel, and latch (B) re-engages the driveshield.
2. Engage rubber latches (A).

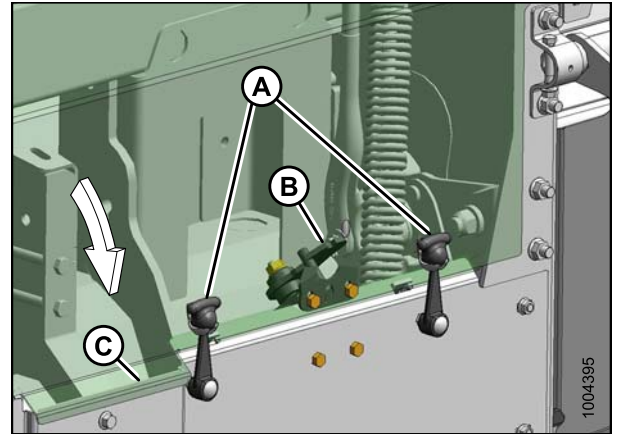

Figure 3.37: Driveshield

3.11 Closing Cutterbar Doors

The procedure for closing cutterbar doors varies depending on whether the header/mower conditioner was sold in North America or not.

Refer to the relevant procedure:

- [3.11.1 Closing the Cutterbar Doors: North American Header or Mower Conditioner, page 28](#)
- [3.11.2 Closing the Cutterbar Doors: Export Header or Mower Conditioner, page 30](#)

3.11.1 Closing the Cutterbar Doors: North American Header or Mower Conditioner

Follow these steps to close the cutterbar doors on a North American header or mower conditioner:

CAUTION

To avoid injury, keep hands and fingers away from corners of doors when closing.

1. Holding the door open, lift the safety door latch (A) to disengage its lock, then move the door down to its closed position over the cutterbar.

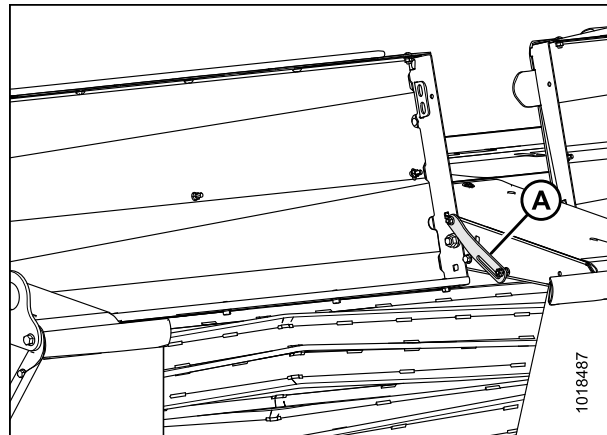

Figure 3.38: Cutterbar Doors

INSTALLATION INSTRUCTIONS

- Hook curtain latches (A).

NOTE:

Ensure that curtains hang properly and completely enclose cutterbar area.

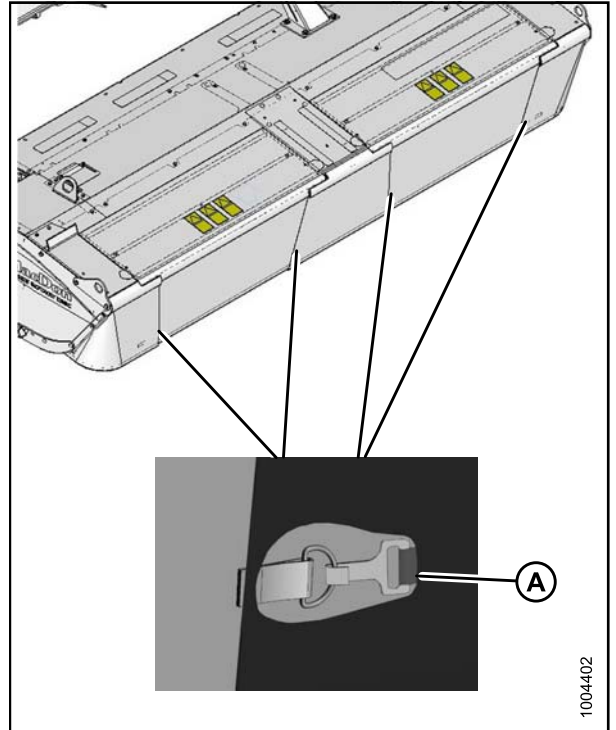

Figure 3.39: Curtain Latches: 16-Ft. PT

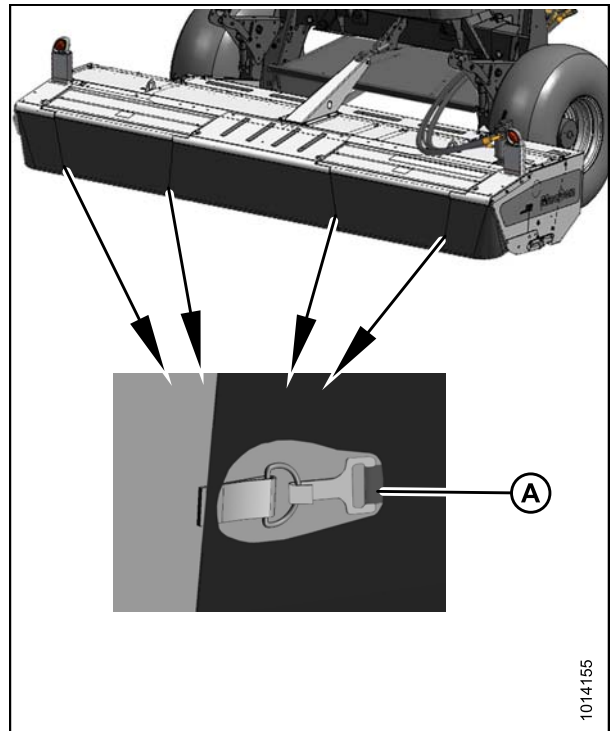

Figure 3.40: Curtain Latches: 16-Ft. SP

INSTALLATION INSTRUCTIONS

3.11.2 Closing the Cutterbar Doors: Export Header or Mower Conditioner

To close the cutterbar doors on an export header or mower conditioner follow these steps:

CAUTION

To avoid injury, keep hands and fingers away from corners of doors when closing.

1. Pull at top and move to closed position. Ensure latch (A) has engaged the door.

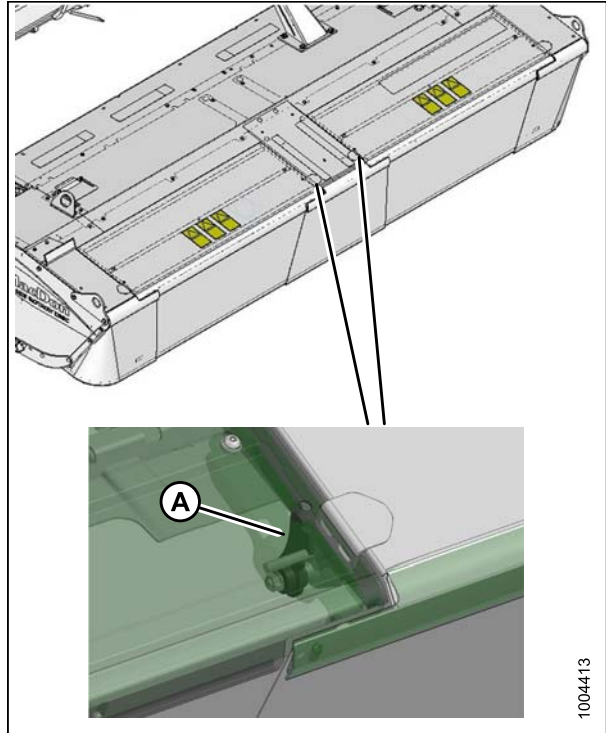

Figure 3.41: Cutterbar Door Latch: 16-Ft. PT

INSTALLATION INSTRUCTIONS

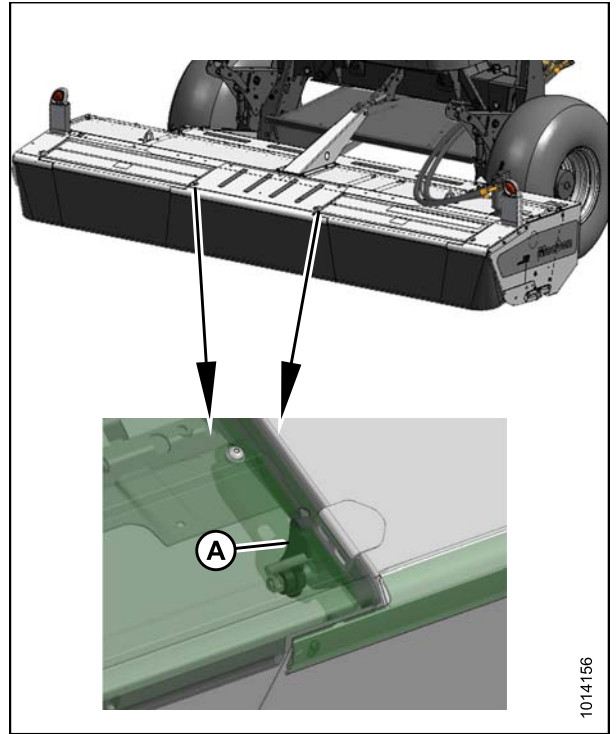

Figure 3.42: Cutterbar Door Latch: 16-Ft. SP

- 2. Hook curtain latches (A).

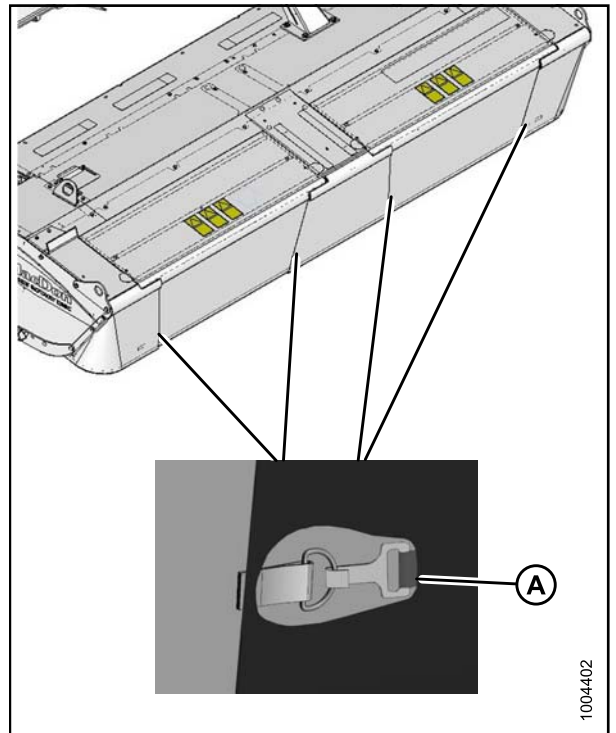

Figure 3.43: Curtain Latches: 16-Ft. PT

INSTALLATION INSTRUCTIONS

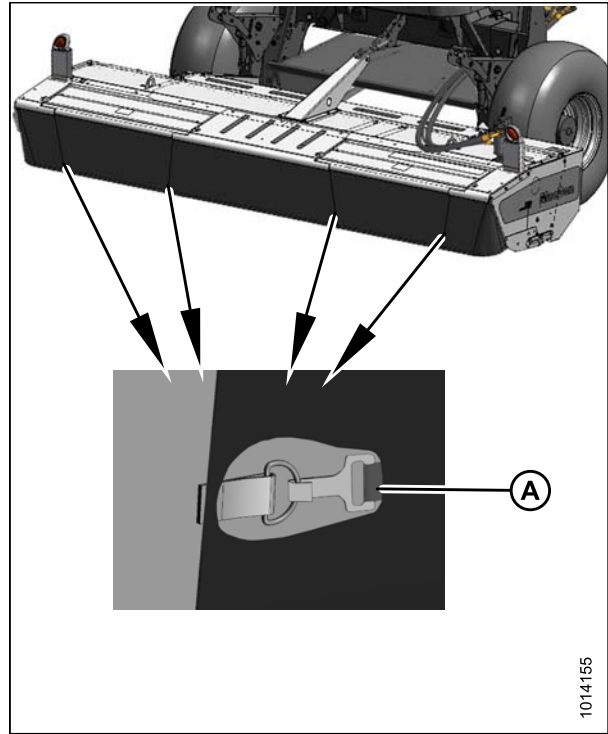

Figure 3.44: Curtain Latches: 16-Ft. SP

1014155

3.12 Replacing Left-Hand Hazard Light

To replace the left-hand hazard light and lamp bracket, follow these steps:

1. Place lamp assembly (C) on header/mower conditioner and secure with four bolts (B).

NOTE:

Ensure amber reflector (D) faces the front of the machine.

2. Connect wires to wiring harness (A).

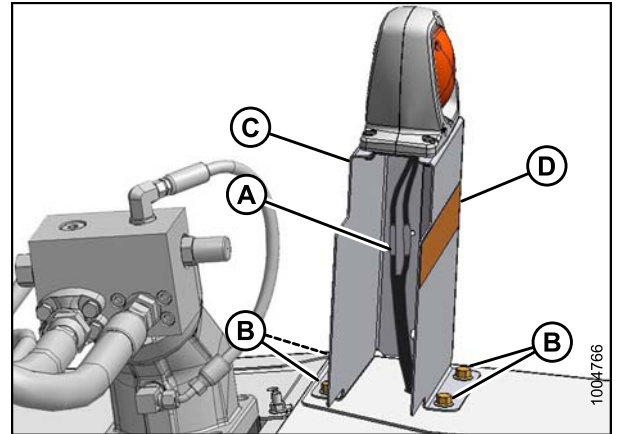

Figure 3.45: Hazard Light

MacDon Industries Ltd.

680 Moray Street
Winnipeg, Manitoba
Canada R3J 3S3
t. (204) 885-5590
f. (204) 832-7749

MacDon, Inc.

10708 N. Pomona Avenue
Kansas City, Missouri
United States 64153-1924
t. (816) 891-7313
f. (816) 891-7323

MacDon Australia Pty. Ltd.

A.C.N. 079 393 721
P.O. Box 243, Suite 3, 143 Main Street
Greensborough, Victoria, Australia 3088
t. 03 9432 9982
f. 03 9432 9972

LLC MacDon Russia Ltd.

123317 Moscow, Russia
10 Presnenskaya nab, Block C
Floor 5, Office No. 534, Regus Business Centre
t. +7 495 775 6971
f. +7 495 967 7600

CUSTOMERS

MacDon.com

DEALERS

Portal.MacDon.com

Trademarks of products are the marks of their
respective manufacturers and/or distributors.

Printed in Canada