

Swath Compressor for M Series Windrowers

Setup, Operation, and Parts Manual

262303 Revision A

Original Instruction

Swath Compressor for M Series Windrowers

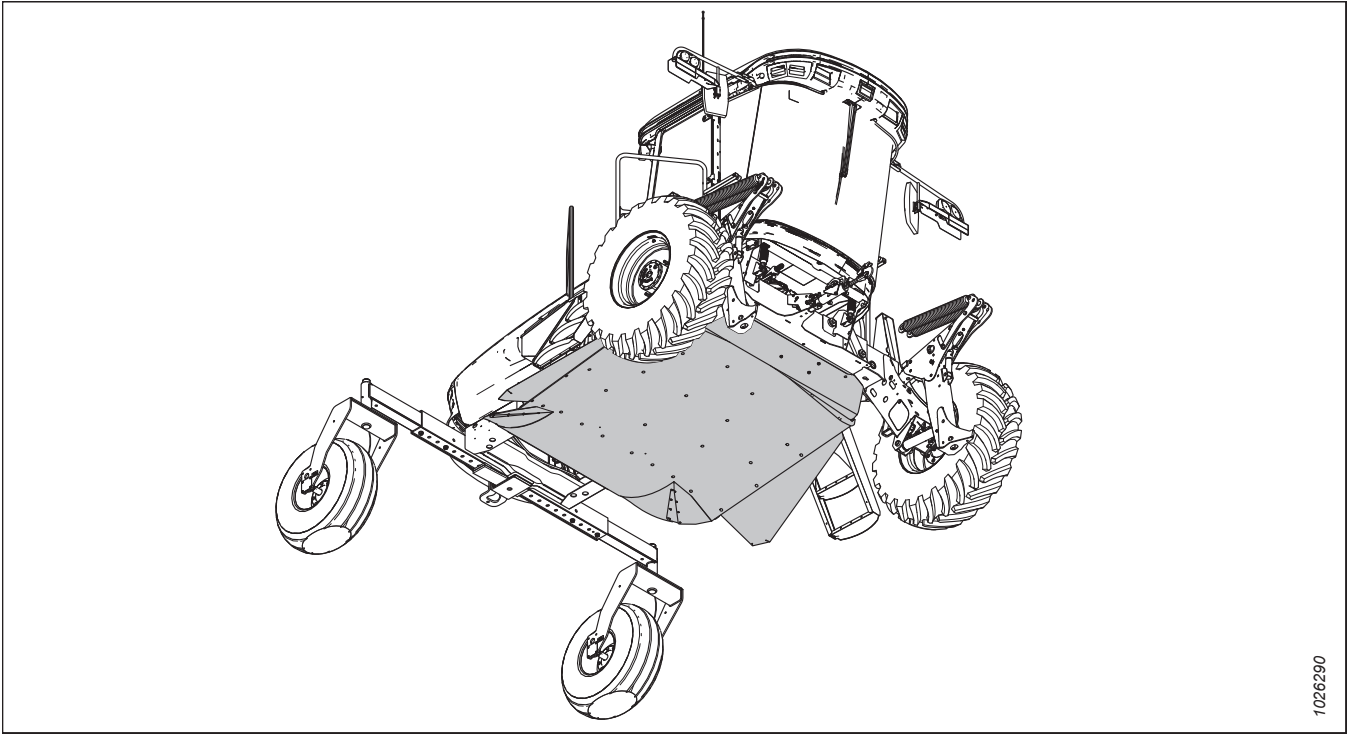

1026290

Published October 2023

© 2023 MacDon Industries, Ltd.

The information in this publication is based on the information available and in effect at the time of printing. MacDon Industries, Ltd. makes no representation or warranty of any kind, whether expressed or implied, with respect to the information in this publication. MacDon Industries, Ltd. reserves the right to make changes at any time without notice.

Introduction

The MacDon Swath Compressor is a large, formed polyethylene sheet designed to mount to the underside of a MacDon M155, M155E4, or M205 Windrower. The MacDon Swath Compressor is designed for use with D Series Draper Headers cutting canola.

Your Machine

The swath compressor is compatible with M155, M155E4, or M205 Windrowers equipped with the CDM5 version of the cab display module (MD #183920) and the following minimum software requirements:

- CDM5 version 512 or newer
- WCM2 version 236 or newer
- WCM3 version 116 or newer

The swath compressor shapes the windrow and anchors it into the stubble behind the header to help prevent shelling in ripe conditions and wind damage. Excessive compression by a swath compressor or roller can increase losses from crop shelling, and may increase drying time; inadequate compression can leave a windrow prone to wind damage.

The swath compressor height can be adjusted and monitored with the cab display. Height can be adjusted for crop ripeness, yield, and the amount of compression required. The swath compressor will automatically lift up if an Operator stops and reverses the windrower.

Your Warranty

When setting up the machine or making adjustments, review and follow the recommended machine settings in all relevant MacDon publications. Failure to do so may compromise machine function and machine life and may result in a hazardous situation.

MacDon provides warranty for Customers who operate and maintain their equipment as described in this manual. A copy of the MacDon Industries Limited Warranty Policy, which explains this warranty, should have been provided to you by your Dealer. Damage resulting from any of the following conditions will void the warranty:

- Accident
- Misuse
- Abuse
- Improper maintenance or neglect
- Abnormal or extraordinary use of the machine
- Failure to use the machine, equipment, component, or part in accordance with the manufacturer's instructions

Your Manual

The following conventions are used in this document:

- M155, M155E4, and M205 Windrowers are Dual Direction[®], meaning the windrower can be driven in cab-forward or engine-forward modes. When referencing specific locations on the machine, this manual always assumes a cab-forward direction when using the terms right and left.
- Unless otherwise noted, use the standard torque values provided in Chapter [6 Reference, page 57](#) of this document.

NOTE:

Keep your MacDon publications up-to-date. The most current version can be downloaded from our website (www.macdon.com) or from our Dealer-only site (<https://portal.macdon.com>) (login required).

If the shipment is damaged or is missing parts, contact shortageanddamage@macdon.com.

Call your MacDon Dealer if you need assistance, information, or additional copies of this manual.

This manual is currently available in English only.

Summary of Changes

At MacDon, we're continuously making improvements; occasionally these improvements affect product documentation. The following list provides an account of major changes from the previous version of this document.

Section	Summary of Change	Internal Use Only
<i>Introduction, page i</i>	Added contact information for damaged or missing parts in the shipment.	Technical Publications
–	Removed irrelevant safety topics (tire, battery, and engine).	Technical Publications
<i>1.8 Understanding Safety Signs, page 10</i>	Updated descriptions of safety decals (MD #184372) and (MD #166466) to be consistent with other MacDon manuals.	Technical Publications, Safety
	Added missing information to the descriptions of safety decals (MD #174683) and (MD #291638).	
<i>2.2.3 Installing Auxiliary Lift Manifold, page 24</i>	Corrected wrong plugs P55 and P59 to plugs P72 and P73.	Product Support
<i>2.2.6 Installing Shield Assembly, page 28</i>	Added a step and a hazard statement.	Technical Publications
	Updated the illustration of the front deflector.	ECN 60665
	Updated the illustration of the side deflector in working position.	ECN 62272
<i>3.2.1 Setting up Swath Compressor, page 36</i>	Added a step and a hazard statement.	Technical Publications
<i>3.2.3 Adjusting Side Deflectors, page 38</i>	Updated the illustration of the side deflector adjustment.	ECN 62272
<i>4.1 Removing Swath Compressor Shield, page 41</i>	Added a step and a hazard statement.	Technical Publications
<i>5.1 Abbreviations, page 44</i>	Added topic.	Technical Publications
<i>5.2 Serial Number Breaks, page 45</i>	Added topic.	Technical Publications
<i>5.3 Swath Compressor Shield Assembly, page 46</i>	Replaced weldment support (MD #306165) with weldment support (MD #306660).	ECN 62272
	Replaced left weldment deflector (MD #277410) with left weldment deflector (MD #306661).	ECN 62272
	Replaced right weldment deflector (MD #277411) with right weldment deflector (MD #306662).	ECN 62272
<i>5.4 Swath Compressor Hydraulics and Supports, page 48</i>	Removed hydraulic hose (MD #277044) and increased the quantity of hydraulic hose (MD #277041) from 1 to 2.	ECN 61459
	Replaced front deflector (MD #128699) with front deflector (MD #310620). Updated the illustration.	ECN 60665
	Replaced up-lock decal (MD #128974) with deck lower lock decal (MD #291638).	ECN 55494
<i>6.1.5 O-Ring Boss Hydraulic Fittings – Adjustable, page 62</i>	Updated the torque specs in the table to match Parker recommended torque values.	ECN 64539
<i>6.1.6 O-Ring Boss Hydraulic Fittings – Non-Adjustable, page 64</i>	Updated the torque specs in the table to match Parker recommended torque values.	ECN 64539

Section	Summary of Change	Internal Use Only
<i>6.1.7 O-Ring Face Seal Hydraulic Fittings, page 64</i>	Corrected torque values in the table: <ul style="list-style-type: none"> • Size -6: rounded lbf·ft from 29 up to 30. • Size -24: corrected “Thread Size” from 1-2 to 2. 	Technical Publications
–	Removed swath compressor index entries.	Technical Publications
<i>Recommended Fluids and Lubricants, page</i>	Added topic.	Technical Publications

TABLE OF CONTENTS

Introduction	i
Summary of Changes.....	iii
Chapter 1: Safety	1
1.1 Safety Alert Symbols	1
1.2 Signal Words	2
1.3 General Safety	3
1.4 Maintenance Safety	5
1.5 Hydraulic Safety	7
1.6 Welding Precautions	8
1.7 Safety Signs	9
1.7.1 Installing Safety Decals.....	9
1.8 Understanding Safety Signs	10
Chapter 2: Installation Instructions	13
2.1 Removing Swath Compressor from Shipping Crate	13
2.2 Installing Swath Compressor.....	16
2.2.1 Installing Frame	16
2.2.2 Installing Reverse Switch and Harness.....	19
Installing Reverse Switch and Harness – Model Year 2017 and Prior	20
Installing Reverse Switch and Harness – Model Year 2018 and Later	23
2.2.3 Installing Auxiliary Lift Manifold.....	24
2.2.4 Connecting Hydraulics	25
2.2.5 Installing Rocker Switch.....	27
2.2.6 Installing Shield Assembly.....	28
Chapter 3: Operation	33
3.1 Activating Swath Compressor	33
3.2 Using Swath Compressor	35
3.2.1 Setting up Swath Compressor.....	36
3.2.2 Adjusting Compression	38
3.2.3 Adjusting Side Deflectors.....	38
3.2.4 Locking and Unlocking Swath Compressor.....	39
Chapter 4: Maintenance	41
4.1 Removing Swath Compressor Shield	41
Chapter 5: Illustrated Parts Lists	43
5.1 Abbreviations	44
5.2 Serial Number Breaks.....	45
5.3 Swath Compressor Shield Assembly.....	46
5.4 Swath Compressor Hydraulics and Supports.....	48
5.4.1 M Series Swath Compressor Completion	52
5.5 Decals	54

TABLE OF CONTENTS

Chapter 6: Reference 57

- 6.1 Torque Specifications 57**
 - 6.1.1 SAE Bolt Torque Specifications 57
 - 6.1.2 Metric Bolt Specifications 59
 - 6.1.3 Metric Bolt Specifications – Cast Aluminum 60
 - 6.1.4 Flare-Type Hydraulic Fittings 61
 - 6.1.5 O-Ring Boss Hydraulic Fittings – Adjustable 62
 - 6.1.6 O-Ring Boss Hydraulic Fittings – Non-Adjustable 64
 - 6.1.7 O-Ring Face Seal Hydraulic Fittings 64
 - 6.1.8 Tapered Pipe Thread Fittings 66
- 6.2 Conversion Chart 67**

Index 69

Predelivery Checklist 73

Recommended Fluids and Lubricants 75

Chapter 1: Safety

Understanding and consistently following safety procedures helps to ensure the safety of machine operators and bystanders.

1.1 Safety Alert Symbols

The safety alert symbol indicates important safety messages in this manual and on safety signs on the machine.

This symbol means:

- **ATTENTION!**
- **BECOME ALERT!**
- **YOUR SAFETY IS INVOLVED!**

Carefully read and follow the safety message accompanying this symbol.

Why is safety important to you?

- Accidents disable and kill
- Accidents cost
- Accidents can be avoided



Figure 1.1: Safety Symbol

1.2 Signal Words

Three signal words, **DANGER**, **WARNING**, and **CAUTION**, are used to alert you to hazardous situations. Two signal words, **IMPORTANT** and **NOTE**, identify non-safety related information.

Signal words are selected using the following guidelines:

DANGER

Indicates an imminently hazardous situation that, if it is not prevented, will result in death or serious injury.

WARNING

Indicates a potentially hazardous situation that, if it is not prevented, could result in death or serious injury. It may also be used to alert you to unsafe practices.

CAUTION

Indicates a potentially hazardous situation that, if it is not prevented, may result in minor or moderate injury. It may also be used to alert you to unsafe practices.

IMPORTANT:

Indicates a situation that, if not prevented, could result in a malfunction or damage to the machine.

NOTE:

Provides additional information or advice.

1.3 General Safety

Operating, servicing, and assembling machinery presents several safety risks. These risks can be reduced or eliminated by following the relevant safety procedures and wearing the appropriate personal protective equipment.

CAUTION

The following general farm safety precautions should be part of your operating procedure for all types of machinery.

Wear all protective clothing and personal safety devices that could be necessary for the job at hand. Do **NOT** take chances. You may need the following:

- Hard hat
- Protective footwear with slip-resistant soles
- Protective glasses or goggles
- Heavy gloves
- Wet weather gear
- Respirator or filter mask

In addition, take the following precautions:

- Be aware that exposure to loud noises can cause hearing impairment. Wear suitable hearing protection devices such as earmuffs or earplugs to help protect against loud noises.

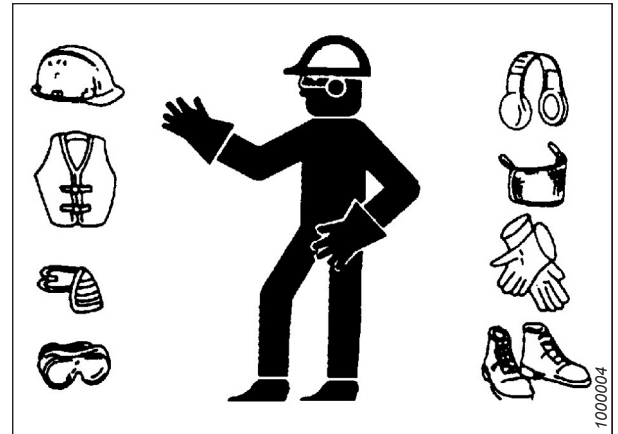

Figure 1.2: Safety Equipment

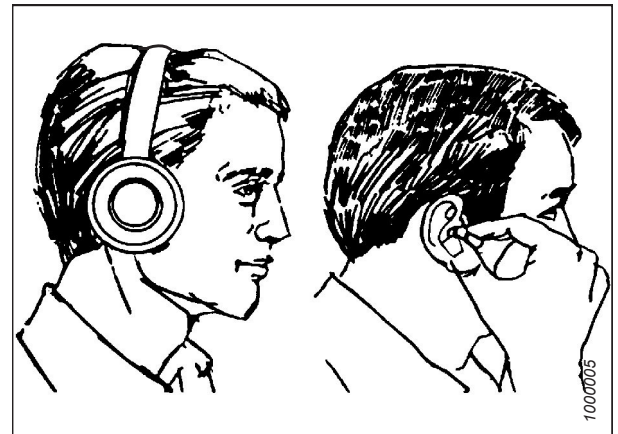

Figure 1.3: Safety Equipment

- Provide a first aid kit in case of emergencies.
- Keep a properly maintained fire extinguisher on the machine. Familiarize yourself with its use.
- Keep young children away from machinery at all times.
- Be aware that accidents often happen when Operators are fatigued or in a hurry. Take time to consider the safest way to accomplish a task. **NEVER** ignore the signs of fatigue.

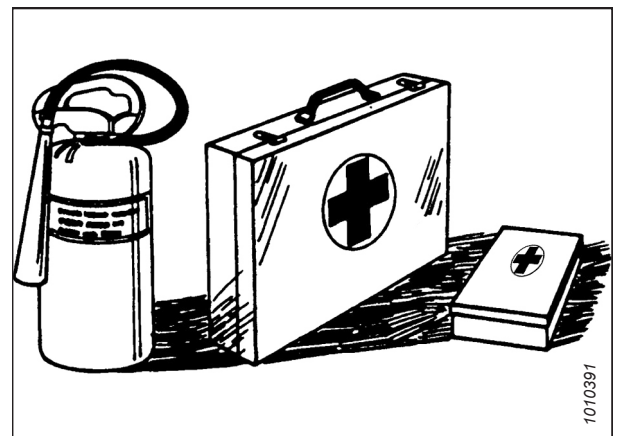

Figure 1.4: Safety Equipment

SAFETY

- Wear close-fitting clothing and cover long hair. **NEVER** wear dangling items such as hoodies, scarves, or bracelets.
- Keep all shields in place. **NEVER** alter or remove safety equipment. Ensure that the driveline guards can rotate independently of their shaft, and that they can telescope freely.
- Use only service and repair parts made or approved by the equipment manufacturer. Parts from other manufacturers may not meet the correct strength, design, or safety requirements.



Figure 1.5: Safety around Equipment

- Keep hands, feet, clothing, and hair away from moving parts. **NEVER** attempt to clear obstructions or objects from a machine while the engine is running.
- Do **NOT** modify the machine. Unauthorized modifications may impair the functionality and/or safety of the machine. It may also shorten the machine's service life.
- To avoid injury or death from the unexpected startup of the machine, **ALWAYS** stop the engine and remove the key from the ignition before leaving the operator's seat for any reason.

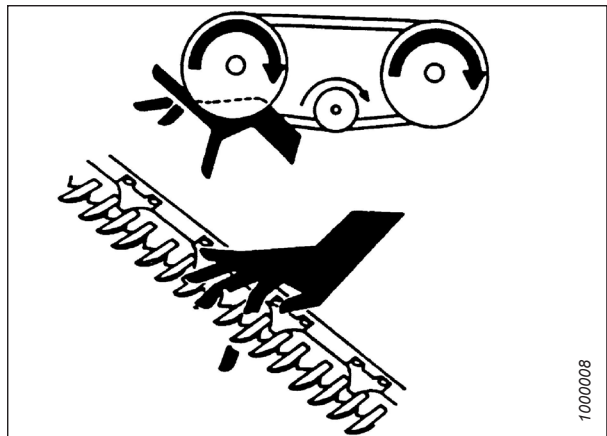

Figure 1.6: Safety around Equipment

- Keep the machine service area clean and dry. Wet and/or oily floors are slippery. Wet spots can be dangerous when working with electrical equipment. Ensure that all electrical outlets and tools are properly grounded.
- Keep the work area well-lit.
- Keep machinery clean. Straw and chaff on a hot engine are fire hazards. Do **NOT** allow oil or grease to accumulate on service platforms, ladders, or controls. Clean machines before they are stored.
- **NEVER** use gasoline, naphtha, or any volatile material for cleaning purposes. These materials may be toxic and/or flammable.
- When storing machinery, cover any sharp or extending components to prevent injury from accidental contact.



Figure 1.7: Safety around Equipment

1.4 Maintenance Safety

Maintaining your equipment safely requires that you follow the relevant safety procedures and wear the appropriate personal protective equipment for the task.

To ensure your safety while maintaining the machine:

- Review the operator's manual and all safety items before operating or performing maintenance on the machine.
- Place all controls in Neutral, stop the engine, set the parking brake, remove the ignition key, and wait for all moving parts to stop before servicing, adjusting, or repairing the machine.
- Follow good shop practices:
 - Keep service areas clean and dry
 - Ensure that electrical outlets and tools are properly grounded
 - Keep the work area well lit
- Relieve pressure from hydraulic circuits before servicing and/or disconnecting the machine.
- Ensure that all components are tight and that steel lines, hoses, and couplings are in good condition before applying pressure to hydraulic systems.
- Keep hands, feet, clothing, and hair away from all moving and/or rotating parts.
- Clear the area of bystanders, especially children, when carrying out any maintenance, repairs, or adjustments.
- Install the transport lock or place safety stands under the frame before working under the machine.
- If more than one person is servicing the machine at the same time, be aware that rotating a driveline or another mechanically driven component by hand (for example, accessing a lubricant fitting) will cause drive components in other areas (belts, pulleys, and knives) to move. Stay clear of driven components at all times.



Figure 1.8: Wet Floors Present Safety Risks

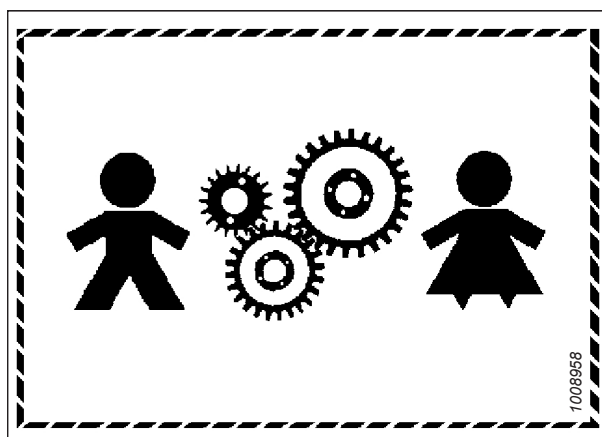

Figure 1.9: Equipment is NOT Safe for Children

SAFETY

- Wear protective gear when working on the machine.
- Wear heavy gloves when working on knife components.

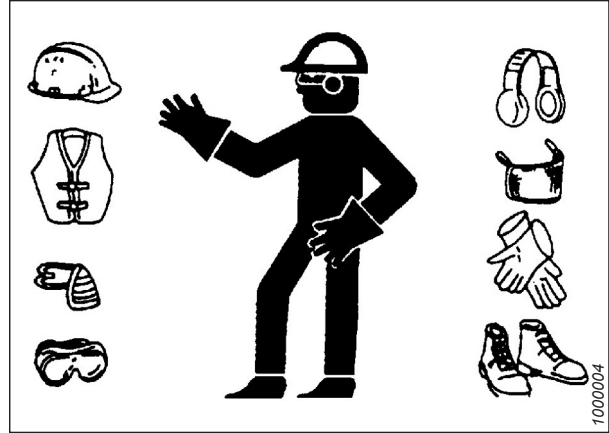

Figure 1.10: Personal Protective Equipment

1.5 Hydraulic Safety

Because hydraulic fluid is under extreme pressure, hydraulic fluid leaks can be very dangerous. Follow the proper safety procedures when inspecting hydraulic fluid leaks and servicing hydraulic equipment.

- Always place all hydraulic controls in **NEUTRAL** before leaving the operator's seat.
- Ensure that all of the components in the hydraulic system are kept clean and in good condition.
- Replace any worn, cut, abraded, flattened, or crimped hoses and steel lines.
- Do **NOT** attempt any makeshift repairs to hydraulic lines, fittings, or hoses by using tapes, clamps, cements, or welding. The hydraulic system operates under extremely high pressure. Makeshift repairs can fail suddenly and create hazardous conditions.

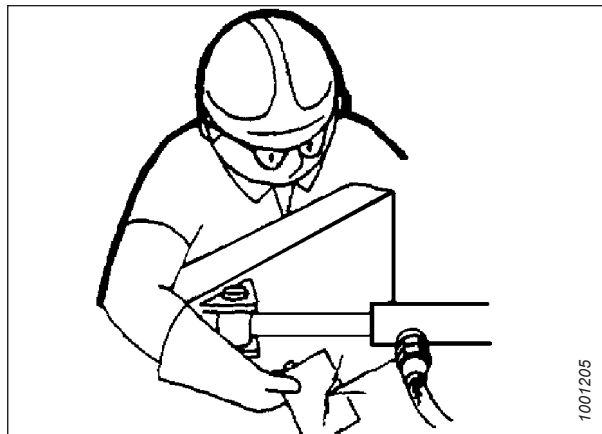

Figure 1.11: Testing for Hydraulic Leaks

- Wear proper hand and eye protection when searching for high-pressure hydraulic fluid leaks. Use a piece of cardboard as a backstop instead of your hands to isolate and identify a leak.
- If you are injured by a concentrated, high-pressure stream of hydraulic fluid, seek medical attention immediately. Serious infection or a toxic reaction can develop from hydraulic fluid piercing the skin.

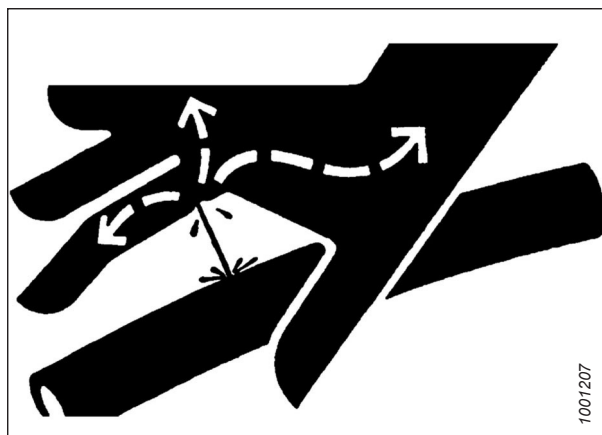

Figure 1.12: Hydraulic Pressure Hazard

- Ensure that all components are tight and that steel lines, hoses, and couplings are in good condition before applying pressure to a hydraulic system.

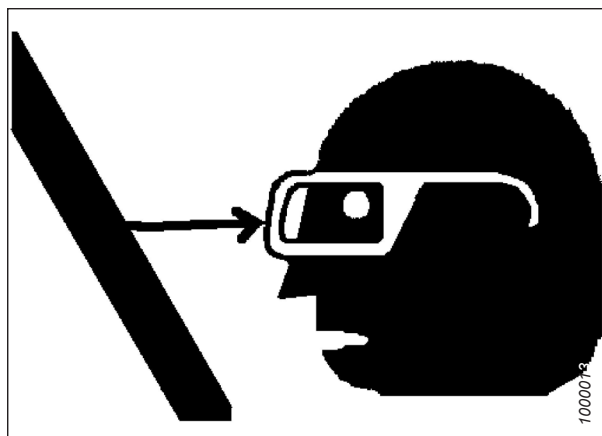

Figure 1.13: Safety around Equipment

1.6 Welding Precautions

The high current and voltage spikes associated with welding can cause damage to the electronic components on the windrower. Before attempting to weld any part of the windrower or an attached header, disconnect all of the electronic module harness connections as well as the battery cables. For further instructions, contact your Dealer.

1.7 Safety Signs

Safety signs are decals placed on the machine where there is a risk of personal injury, or where the Operator should take extra precautions before operating the controls. They are usually yellow.

- Keep safety signs clean and legible at all times.
- Replace safety signs that are missing or illegible.
- If the original part on which a safety sign was installed is replaced, ensure that the repair part displays the current safety sign.
- Replacement safety signs are available from your MacDon Dealer.

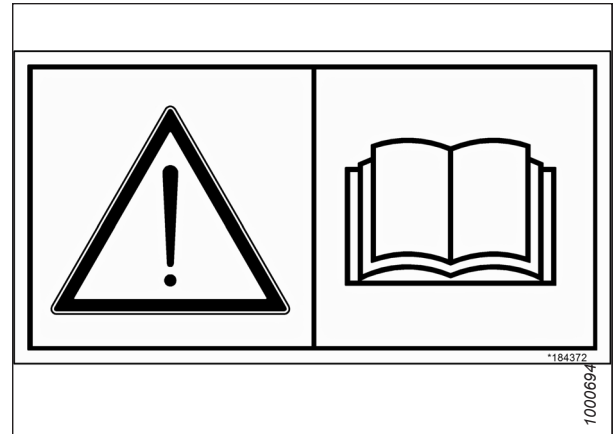

Figure 1.14: Operator's Manual Decal

1.7.1 Installing Safety Decals

Worn or damaged safety decals will need to be removed and replaced.

1. Decide exactly where you are going to place the decal.
2. Clean and dry the installation area.
3. Remove the smaller portion of the split backing paper.
4. Place the decal in position and slowly peel back the remaining paper, smoothing the decal as it is applied.
5. Prick small air pockets with a pin and smooth them out.

1.8 Understanding Safety Signs

Refer to this section to learn the hazards that each type of safety decal denotes.

MD #184372

General hazard pertaining to machine operation and servicing

DANGER

To prevent injury or death from the improper or unsafe operation of the machine:

- Read the operator's manual and follow all safety instructions. If you do not have a manual, obtain one from your Dealer.
- Do **NOT** allow untrained persons to operate the machine.
- Review these safety instructions with all machine Operators every year.
- Ensure that all safety signs are installed and are legible.
- Make certain that bystanders are clear of the header before starting the engine and during operation of the header.
- Keep riders off of the machine.
- Keep all shields in place. Stay clear of moving parts.
- Disengage the header drive, put the transmission into Neutral, and wait for all movement to stop before leaving the operator's position.
- Stop the engine and remove the key from the ignition before servicing, adjusting, lubricating, cleaning, or unplugging the machine.
- Before servicing a header in the raised position, engage the cylinder safety props.
- Display a slow-moving vehicle emblem and activate the header's warning lights when operating the header on roadways (unless these actions are prohibited by law).

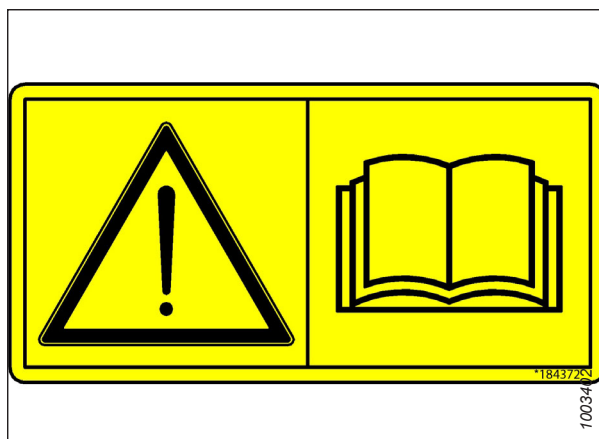

Figure 1.15: MD #184372

SAFETY

MD #166466

High-pressure oil hazard

WARNING

High-pressure hydraulic fluid can penetrate human skin, which can cause serious injury such as gangrene, which can be fatal. To prevent this:

- Do **NOT** go near hydraulic fluid leaks.
- Do **NOT** use a finger or skin to check for hydraulic fluid leaks.
- Lower the load or relieve the pressure in the hydraulic system before loosening any hydraulic fittings.
- If you are injured, seek emergency medical help. **IMMEDIATE** surgery is required to remove hydraulic fluid which has penetrated the skin.



Figure 1.16: MD #166466

MD #174683

Pinch point hazard

CAUTION

To prevent injury:

- Do **NOT** reach into the pinch area.



Figure 1.17: MD #174683

SAFETY

MD #291638

Lock – swath compressor deck

DANGER

To prevent injury:

- Engage lock when swath compressor is not in use.
- Lock compressor shield before servicing or working under the windrower.
- Lock compressor shield before operating in engine-forward mode.

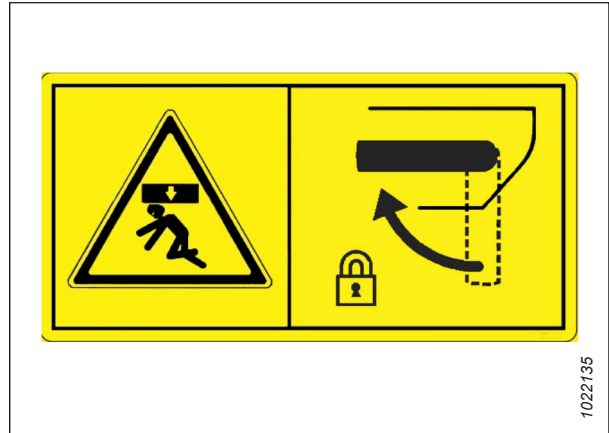

Figure 1.18: MD #291638

Chapter 2: Installation Instructions

To unpack and install the swath compressor, follow these procedures in order.

2.1 Removing Swath Compressor from Shipping Crate

Follow these steps to unpack the swath compressor from the shipping crate. Retain all parts for installation unless instructed to discard.

1. Remove and discard top cross members (A) from the shipping crate.

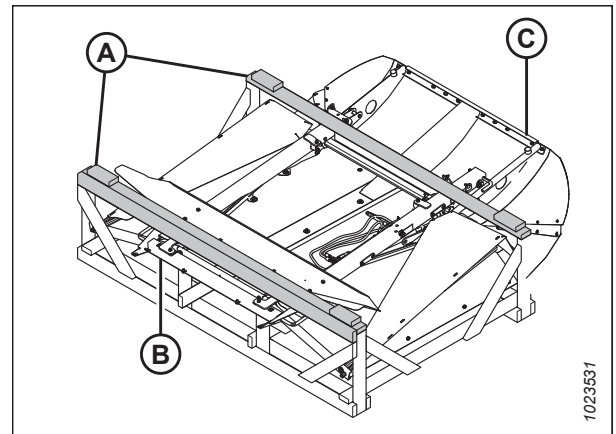

Figure 2.1: Shipping Configuration

A - Cross Members

B - Front

C - Rear

2. Remove four bolts (A) securing deflector (B) to the left and right supports, and remove deflector (B). Retain the hardware for reinstallation.

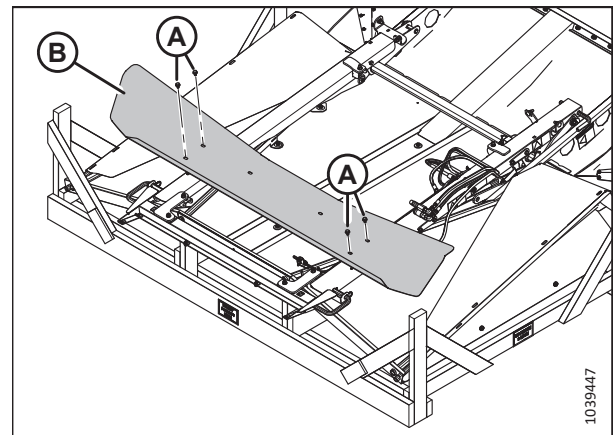

Figure 2.2: Front Deflector

INSTALLATION INSTRUCTIONS

3. Remove four bolts and nuts (A) and remove two bar clamps (B) from front pivot support (C).

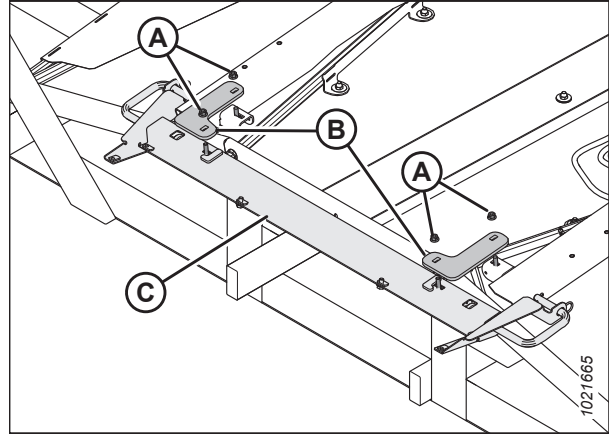

Figure 2.3: Front Pivot Support

4. Remove the bolts and nuts (B) securing front support (A) to the left and right supports.
5. Remove hairpins (C) from pivot pins (D) and pull the pivot pins to disengage them from the side supports. Remove front pivot support (A).

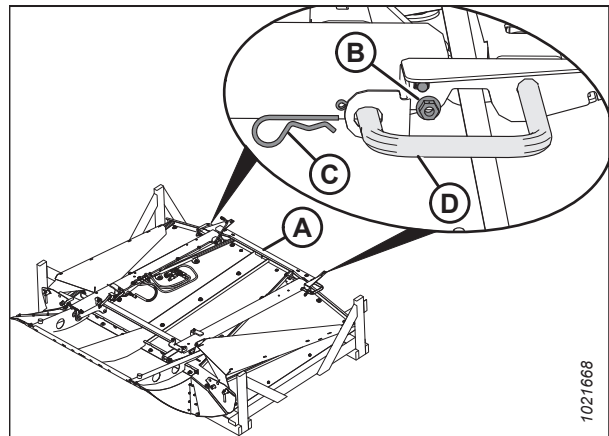

Figure 2.4: Front Pivot Support

6. Remove nut and bolt (A) and remove pivot pin (B) from the left support.

NOTE:

If necessary, loosen handle (C) and adjust the deflector so pin (B) can be removed.

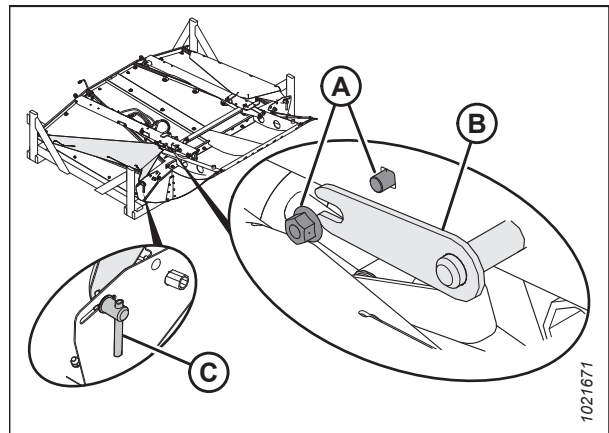

Figure 2.5: Left Support

INSTALLATION INSTRUCTIONS

7. Release latch (A) and remove left support (B), including the cylinder and the hydraulic hoses.
8. Remove the shipping wire securing the hoses to the support.

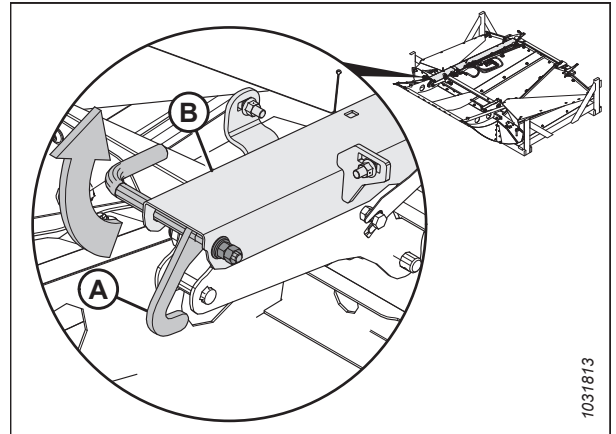

Figure 2.6: Left Support

9. Remove nut and bolt (A) and remove pivot pin (B) from the right support.

NOTE:

If necessary, loosen handle (C) and adjust the deflector so pin (B) can be removed.

10. Remove right support (D).

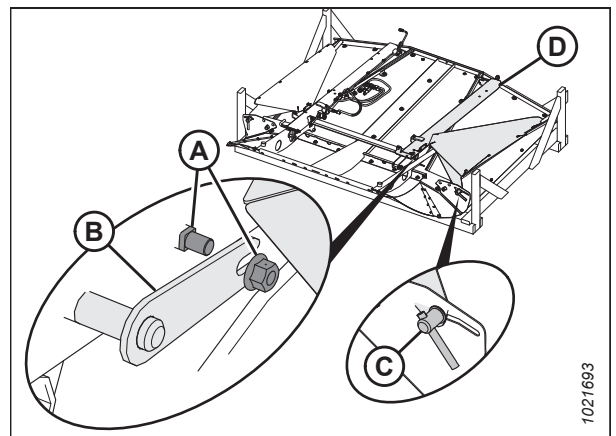

Figure 2.7: Right Support

11. Remove rock shaft (A).
12. Remove four lag screws (B) securing the swath compressor to its shipping crate. Discard the lag screws and the washers.
13. Leave the swath compressor on the shipping pallet.

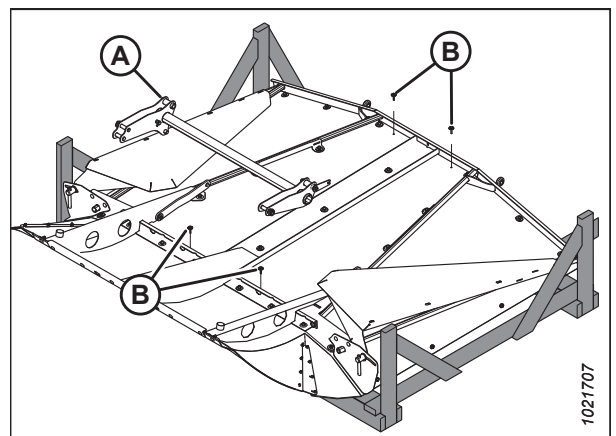

Figure 2.8: Rock Shaft

2.2 Installing Swath Compressor

Follow these steps to install the swath compressor onto an M155, M155E4, or M205 Self-Propelled Windrower. The swath compressor weighs approximately 180 kg (400 lb.).

2.2.1 Installing Frame

The swath compressor frame consists of the front, left, and right supports, and the rock shaft.

1. Loosely attach bar clamps (A) to each side of the front support with two M10 bolts and nuts (B).

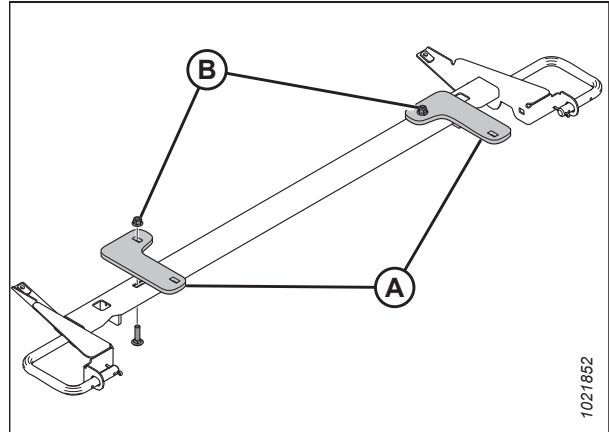

Figure 2.9: Front Support

2. Remove clamp (A) from the end of right support (B) and discard. Retain hardware (C), and repeat on the opposite side of the compressor.

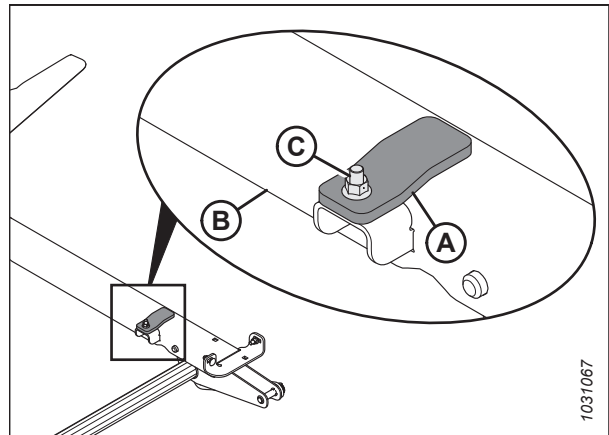

Figure 2.10: Clamp

INSTALLATION INSTRUCTIONS

3. Position front support (A) below the windrower frame at the cab end and adjust bar clamps (C) to hold the support in place.
4. Tighten two bolts (B) on bar clamps (C) to hold the front support in place, but do **NOT** fully tighten.

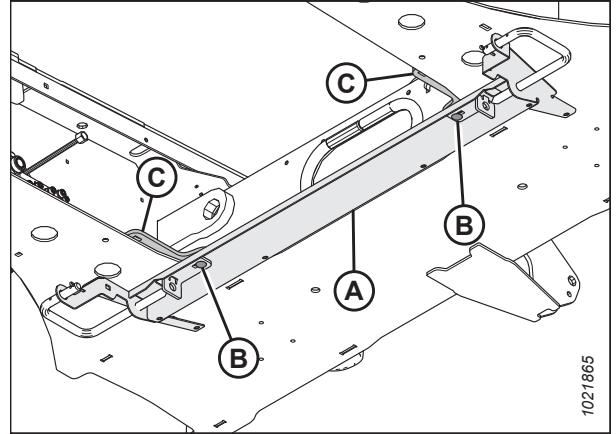

Figure 2.11: Front Support on the Windrower Frame

5. Locate left support (A) onto the left side of the windrower frame as shown, and temporarily clamp it in position.
6. Install M10 x 35 mm bolt (B) and nut through bar clamp (C) and M10 x 20 mm bolt (D) and nut through front support (E). Do **NOT** fully tighten bolts.

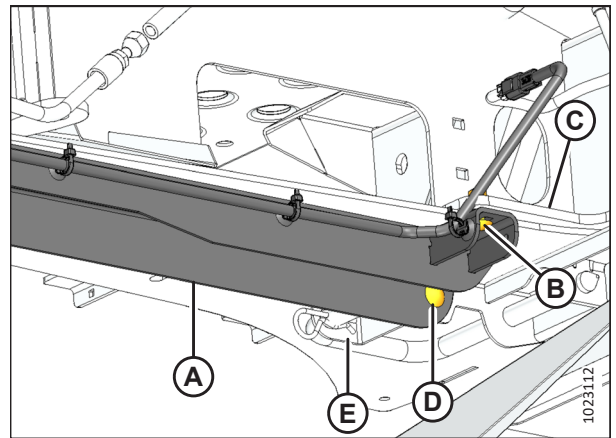

Figure 2.12: Left Support – Front

7. Secure the rear of the left support with M10 x 35 mm bolt (C) and nut through the existing hole in the windrower frame. Do **NOT** fully tighten bolt (C).
8. At the rear of the left support, align a drill with hole in bracket (A) and drill a 10 mm (13/32 in.) hole through the frame.
9. Install M10 x 35 mm bolt (B) and nut through bracket (A) and the frame.

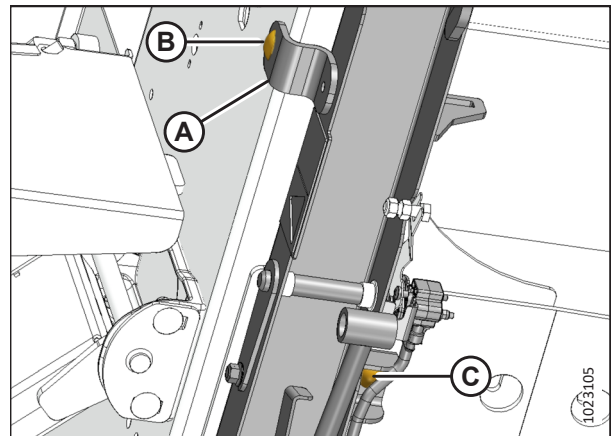

Figure 2.13: Left Support – Rear

INSTALLATION INSTRUCTIONS

10. Position right support (A) onto the right side of the windrower frame as shown, and temporarily clamp it in position.
11. Remove and discard the hardware.
12. Install M10 x 35 mm bolt (B) and nut through bar clamp (C) and M10 x 20 mm bolt (D) and nut through front support (E). Do **NOT** fully tighten bolts.

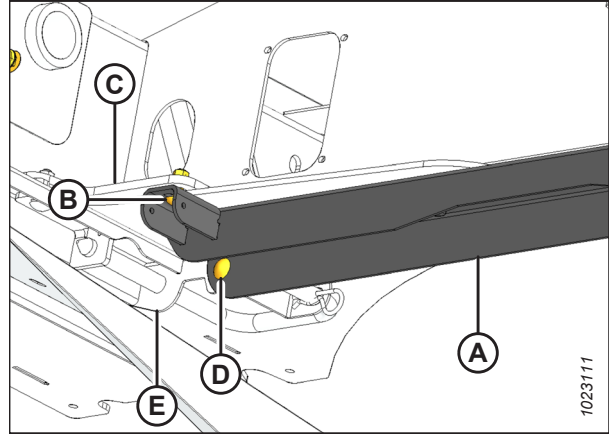

Figure 2.14: Right Support – Front

13. Secure the rear of the right support with M10 x 35 mm bolt (C) and nut through the existing hole in the windrower frame. Do **NOT** fully tighten the hardware.
14. At the rear of the right support, align a drill with hole in bracket (A) and drill a 10 mm (13/32 in.) hole through the frame.
15. Install M10 x 35 mm bolt (B) and nut through bracket (A) and the existing hole in the windrower frame. Do **NOT** fully tighten the hardware.

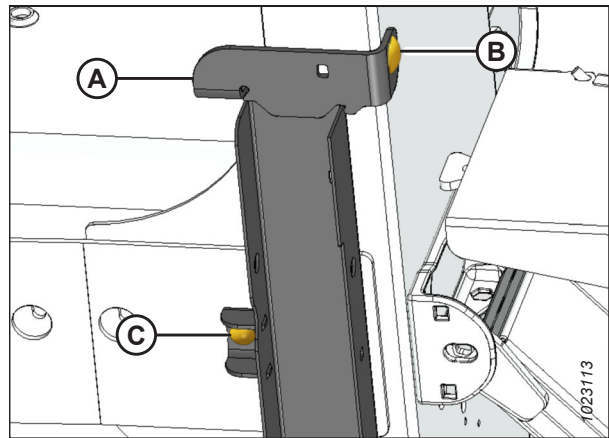

Figure 2.15: Right Support – Rear

16. Position rock shaft lift (A) inside the left and right support channels. Insert pivot pins (B) on both sides, and secure them with M10 x 20 mm bolts and nuts (C). Tighten the hardware.

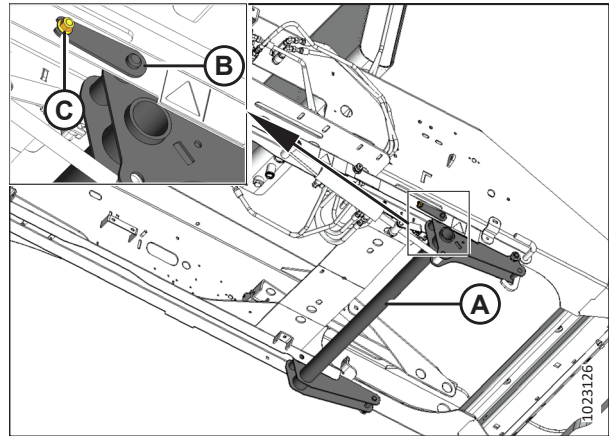

Figure 2.16: Rock Shaft

INSTALLATION INSTRUCTIONS

17. Ensure sensor arm (A) engages bolt (B) on the left rock shaft lift support, and ensure it is not bent or damaged.

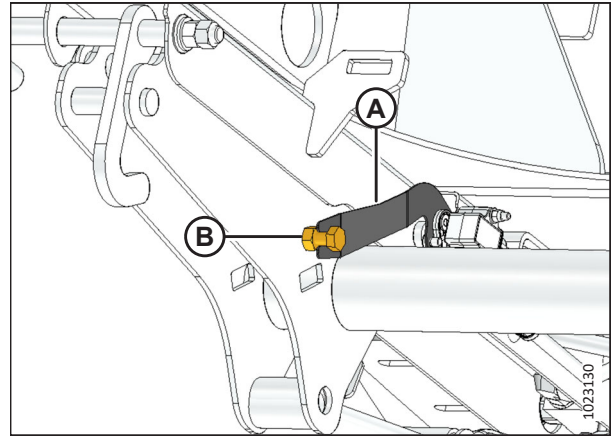

Figure 2.17: Sensor on Left Support

18. Tighten six bolts (A) and torque to 39 Nm (29 lbf-ft).
19. Ensure front clamps (B) engage the windrower frame as much as possible and torque four bolts (C) to 39 Nm (29 lbf-ft).

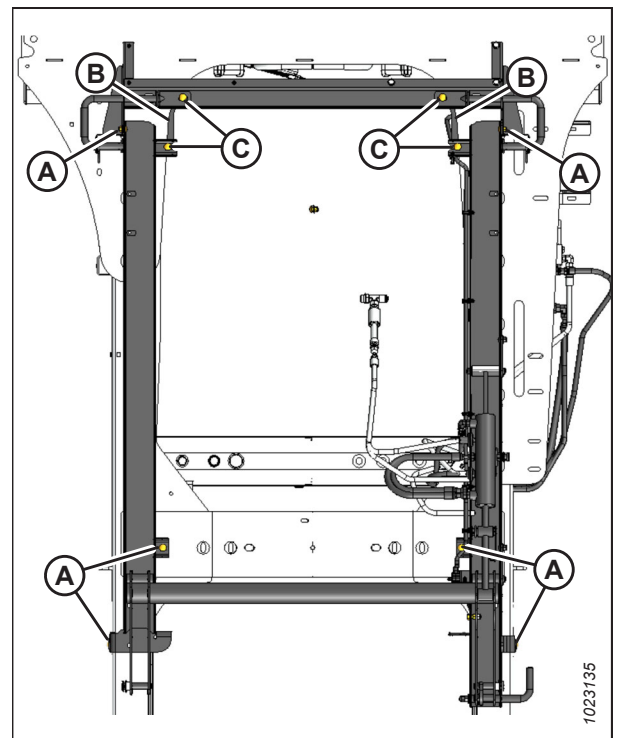

Figure 2.18: View from below the Windrower

2.2.2 Installing Reverse Switch and Harness

Refer to the following procedures to install the reverse switch and harness on your windrower depending on the model year of your machine:

- [Installing Reverse Switch and Harness – Model Year 2017 and Prior, page 20](#)
- [Installing Reverse Switch and Harness – Model Year 2018 and Later, page 23](#)

INSTALLATION INSTRUCTIONS

Installing Reverse Switch and Harness – Model Year 2017 and Prior

Complete the following procedure to install the reverse switch and harness from the completion kit on M155, M155E4, and M205 windrowers built for model year 2017 and prior.

1. Install reverse switch (A) onto the existing bracket as shown with two M6 x 16 mm bolts and flanged lock nuts (B). Align switch support (C) with the existing bracket before tightening nuts.

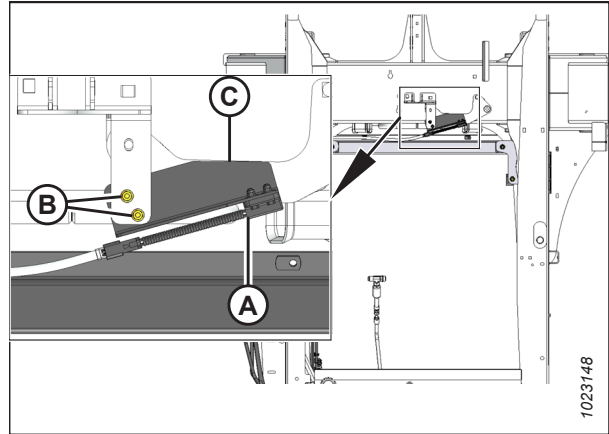

Figure 2.19: Reverse Switch – View From the Top

2. Open the left cab-forward side platform.
3. Locate the harness bundle that contains three-pin plug P97 (A). If the plug is attached to a pressure sensor, remove the plug. Otherwise cut the cable tie securing P97 (A) to the wire bundle.

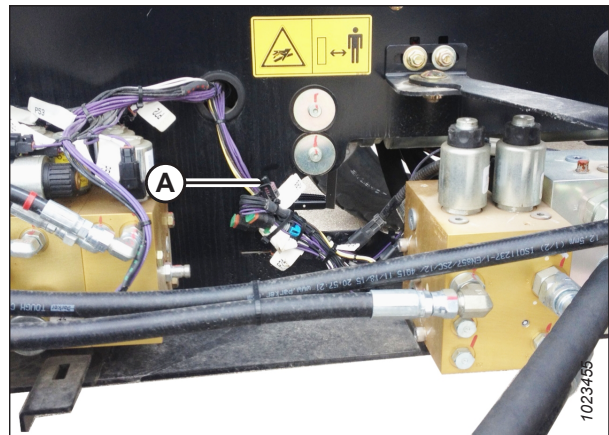

Figure 2.20: Windrower Chassis Harness

NOTE:

P97 (A) may be in use on a windrower equipped with a reel circuit pressure transducer. If so, disable the reel circuit pressure transducer in the CDM.

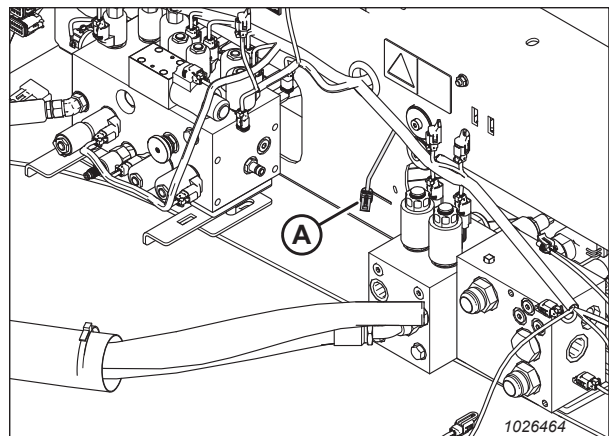

Figure 2.21: Location of P97 on the Windrower Chassis Harness – View from the Left

INSTALLATION INSTRUCTIONS

4. Route swath compressor completion harness (A) (MD #128972) along the forward cross-member. Connect swath compressor connector P97A (B) to plug P97 on the chassis harness.

NOTE:

P97 may need to be repositioned underneath the windrower.

5. Connect swath compressor height sensor plug P97B (C) to existing connector P560A on the compressor harness.
6. Connect swath compressor reverse switch plug P108 (D) on the compressor harness to the reverse switch connector DTM04-2P.
7. Route single wire (E) to the main system harness and into the cab at the left rear corner.
8. Enter the cab and locate the manual holder (A) beneath the trainer's seat. The windrower control module (WCM) (B) is just above the manual holder.

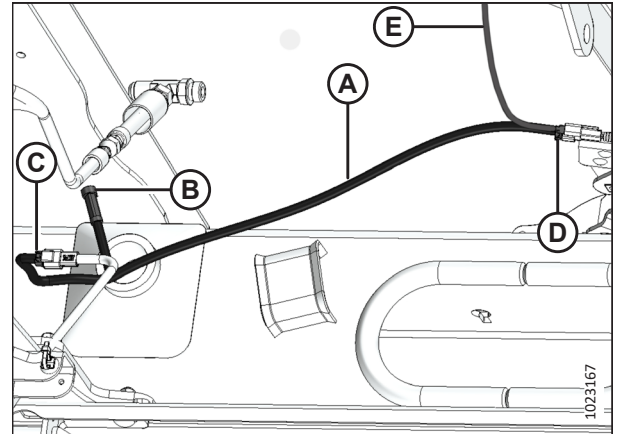

Figure 2.22: Swath Compressor Completion Harness

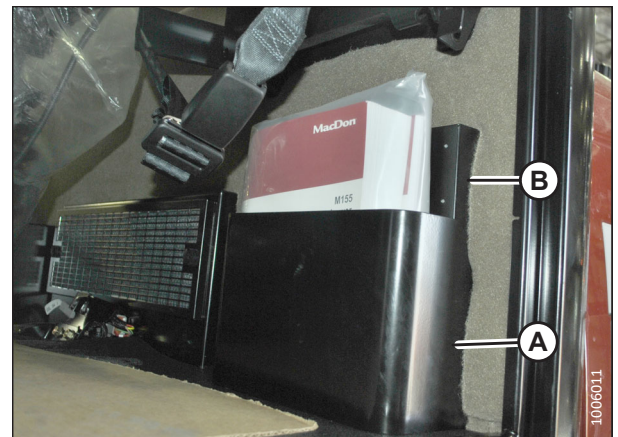

Figure 2.23: Manual Holder and WCM

9. Gently move upholstery (C) on both sides of manual holder (A). Remove two nuts (B) and remove the manual holder.

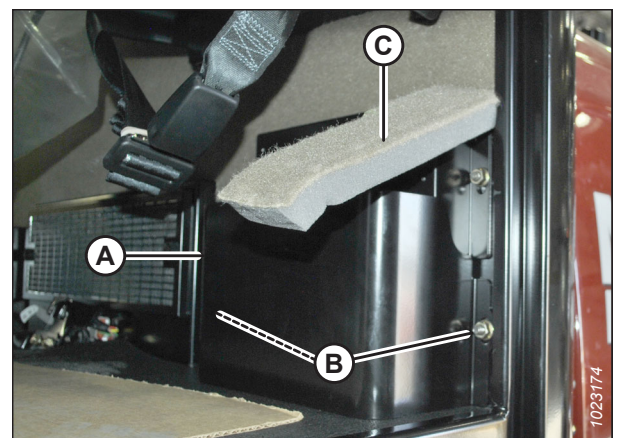

Figure 2.24: Upholstery and Hardware

INSTALLATION INSTRUCTIONS

10. Remove P35 plug (A) from the WCM.



Figure 2.25: WCM and Wiring Harnesses

11. Retrieve single wire (A) from the swath compressor and insert it in position 24 (B) on the harness side of plug P35. Secure wire (A) to existing harness (C) with a plastic cable tie.
12. Attach plug P35 to the WCM.

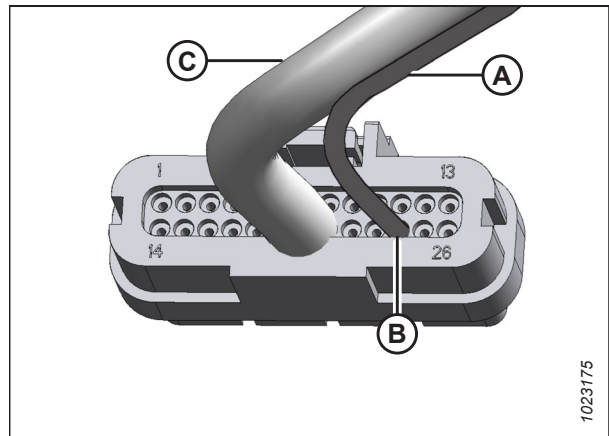

Figure 2.26: P35 Plug

13. Reposition manual holder (A) and secure with two nuts (B). Replace upholstery (C).
14. Secure the swath compressor harness to the existing harness above the forward cross member.

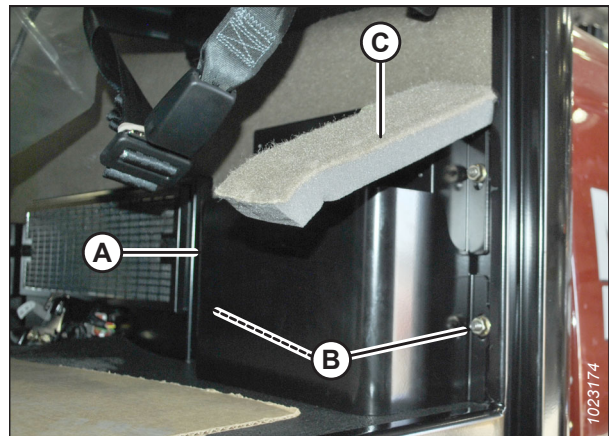

Figure 2.27: Upholstery and Hardware

INSTALLATION INSTRUCTIONS

Installing Reverse Switch and Harness – Model Year 2018 and Later

Complete the following procedure to install the reverse switch and harness from the completion kit on M155, M155E4, and M205 windrowers built for model year 2018 and later:

1. Install reverse switch (A) onto the existing bracket as shown with two M6 x 16 mm bolts and flanged lock nuts (B). Align switch support (C) with the existing bracket before tightening the nuts.
2. Plug reverse switch (A) into plug P108 on the chassis harness (D).

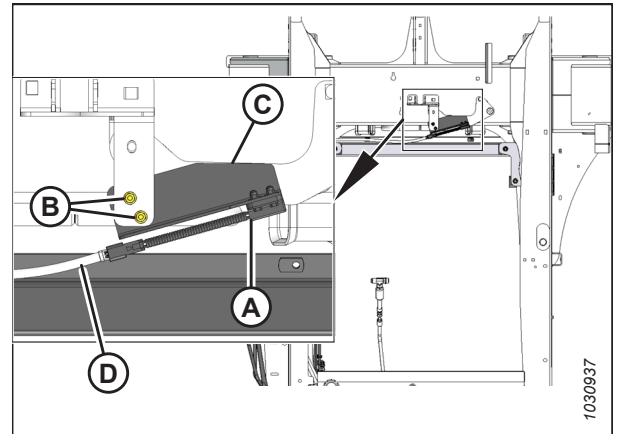

Figure 2.28: Reverse Switch – View From the Top

3. Open the left cab-forward side platform.
4. Locate the harness bundle that contains three-pin plug P97 (A). If the plug is attached to a pressure sensor, remove the plug. Otherwise, cut the cable tie securing P97 (A) to the wire bundle.

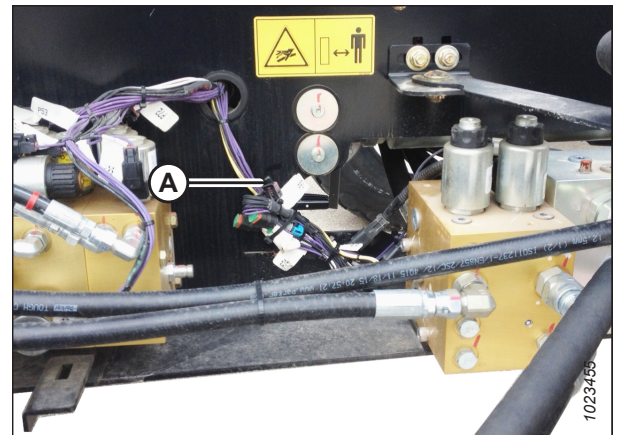

Figure 2.29: Windrower Chassis Harness

NOTE:

P97 (A) may be in use on a windrower equipped with a reel circuit pressure transducer. If so, disable the reel circuit pressure transducer in the CDM.

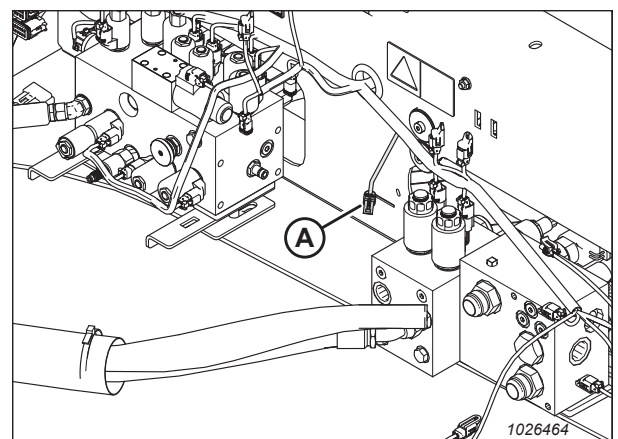

Figure 2.30: Location of P97 on the Windrower Chassis Harness – View from the Left

INSTALLATION INSTRUCTIONS

- Retrieve shorter swath compressor completion harness (A) (MD #306261) from the kit and connect swath compressor connector P97C (B) to plug P97 on the chassis harness.

NOTE:

Plug P97 may need to be repositioned underneath the windrower.

- Connect swath compressor height sensor plug P97D (C) to existing connector P560A on the swath compressor harness.

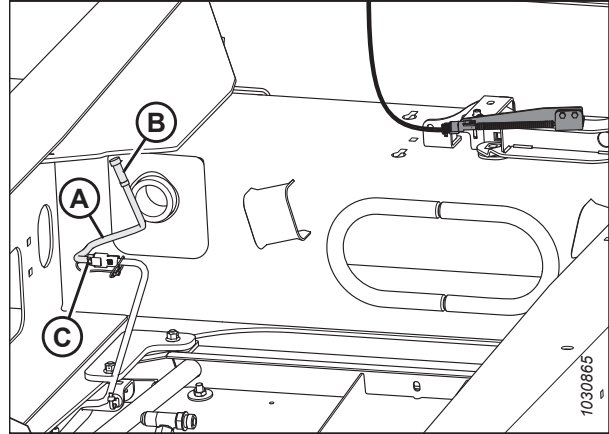

Figure 2.31: Swath Compressor Completion Harness

2.2.3 Installing Auxiliary Lift Manifold

The new auxiliary lift manifold is installed onto existing lift manifold. The swath compressor uses the same plugs as the Double Windrow Attachment.

- Remove fitting (A) and plug (B) from the lift manifold, and retain them for reinstallation.
- Apply grease to O-rings (supplied with lift manifold) and install them in the countersunk port holes where the plug and fitting were removed.

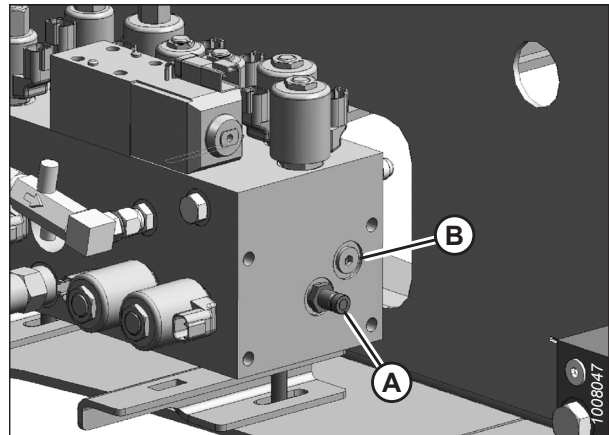

Figure 2.32: Lift Manifold Block

- Assemble the smooth side of new lift manifold (C) onto the existing lift manifold with four 3/8 in. bolts (D) provided in the kit. Use the longer bolts if there are two existing lift manifolds.

NOTE:

If installing new lift manifold (C) onto a windrower paired with a draper header with reel fore-aft, the windrower will already have an auxiliary lift manifold. The new lift manifold is mounted next to the existing one.

- Torque the bolts to 34 Nm (25 lbf-ft).
- Install fitting (A) and plug (B) previously removed into the new lift manifold. If plug (B) is damaged on removal, an extra plug is provided in the kit.

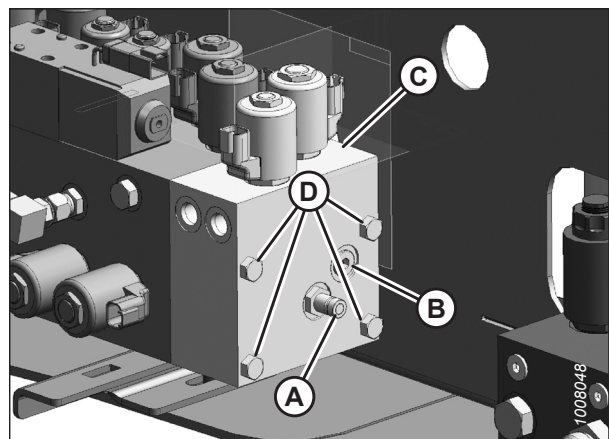

Figure 2.33: New Lift Manifold Block

INSTALLATION INSTRUCTIONS

6. Install 90° elbow fitting (A) into port K on new lift manifold (B).

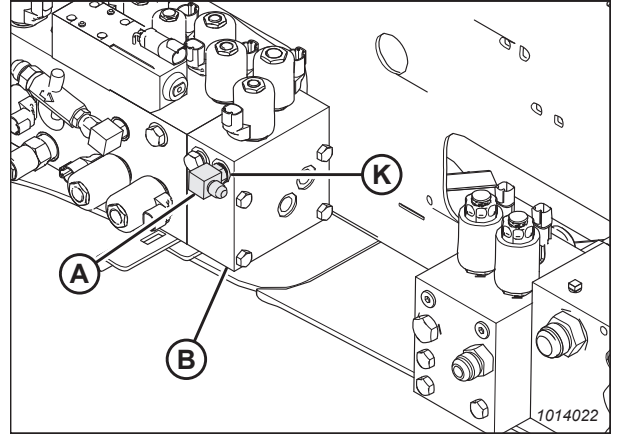

Figure 2.34: New Lift Manifold

7. Connect plugs P72 (A) and P73 (B) from the windrower chassis harness to the solenoids on new lift manifold (C) as shown in the illustration at right.

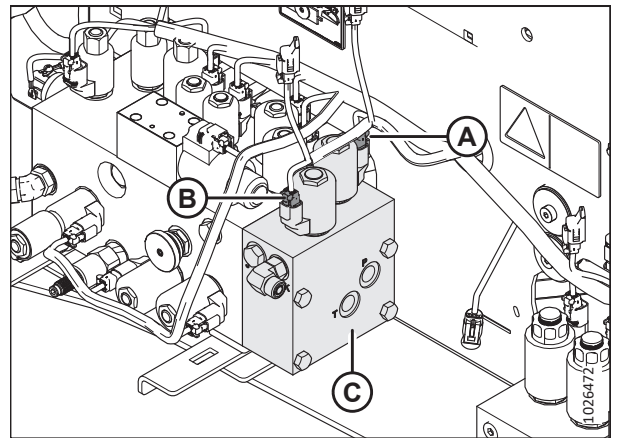

Figure 2.35: New Lift Manifold

2.2.4 Connecting Hydraulics

The hydraulic connections allow the windrower's hydraulics to power and control the swath compressor.

1. Remove and discard quick disconnect couplers (A) and the elbows from the three hoses on the swath compressor.

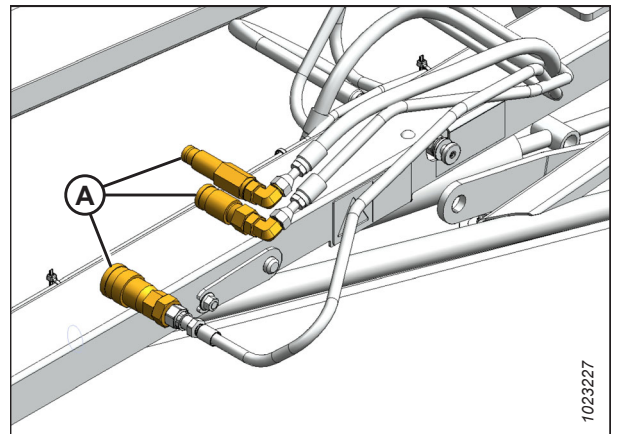

Figure 2.36: Quick Disconnects

INSTALLATION INSTRUCTIONS

2. Remove hose (A) and fitting (B) from charge pump (C).

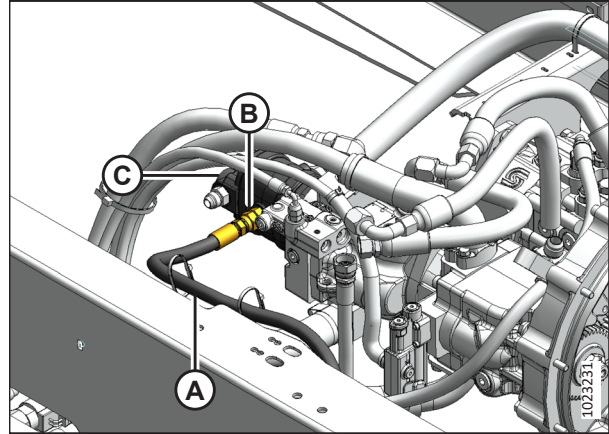

Figure 2.37: M Series Hydraulics

3. Install tee (A) on charge pump, and reconnect hose (B) to tee (A).
4. Retrieve new hose (C) from the shipment and connect it to tee (A) and hose (D) from the pressure-reducing valve forward fitting.

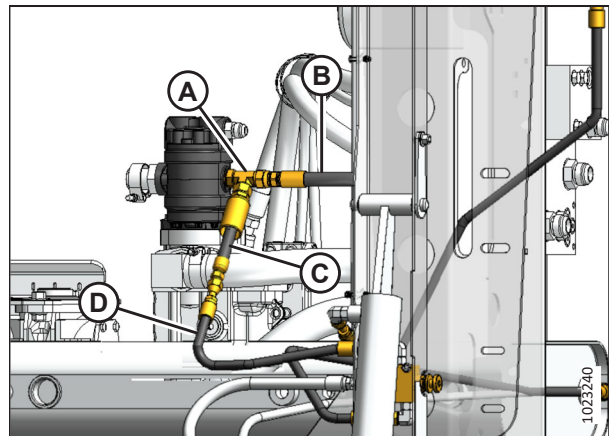

Figure 2.38: Hose Connections – View from under the Windrower

5. Connect hose (A) from the barrel end of cylinder (B) to elbow (C) on the lift manifold.
6. Remove and discard the plug from the tank at location (D). Install elbow (E).
7. Connect hose (F) from pressure-reducing valve (G) to elbow (E) on the tank.

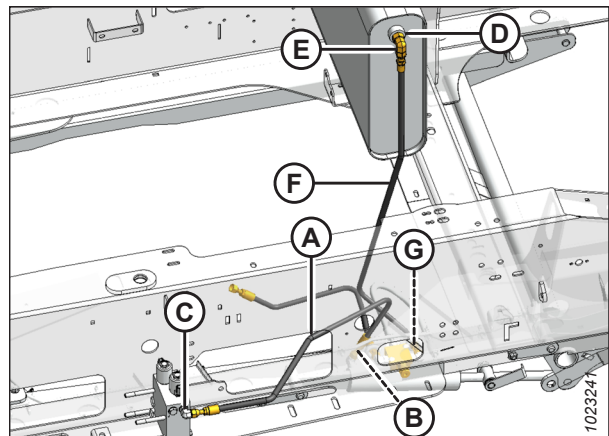

Figure 2.39: Hose Connections

INSTALLATION INSTRUCTIONS

2.2.5 Installing Rocker Switch

Remove the knockout in the console control plate beside the operator's seat to install the rocker switch.

1. Inside the windrower cab, remove cover (A) from the console by removing five screws (B).

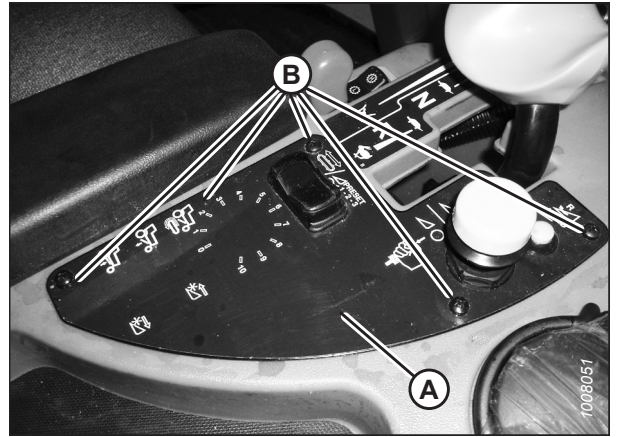

Figure 2.40: Console Control Plate

2. Remove the knockout in cover (A) for the rocker switch and file down the burrs.

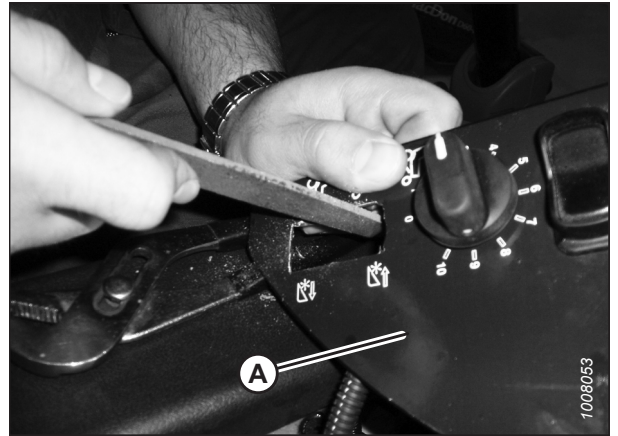

Figure 2.41: Console Control Plate

3. Install rocker switch (A) (MD #109575) into the cover. The side with the prongs should be next to the operator's seat.

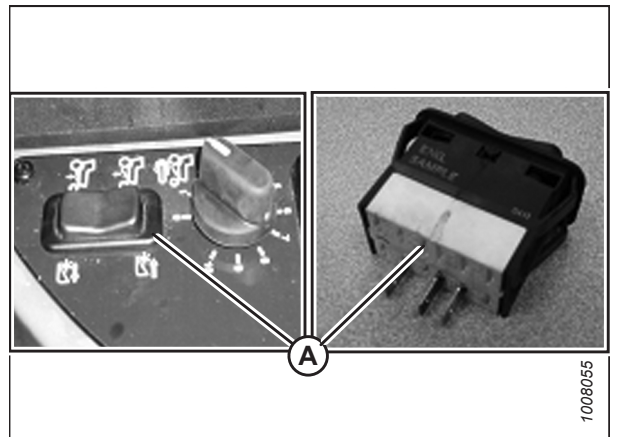

Figure 2.42: Rocker Switch

INSTALLATION INSTRUCTIONS

4. Install the rocker switch into plug (A). The plug comes prewired into the windrower console.

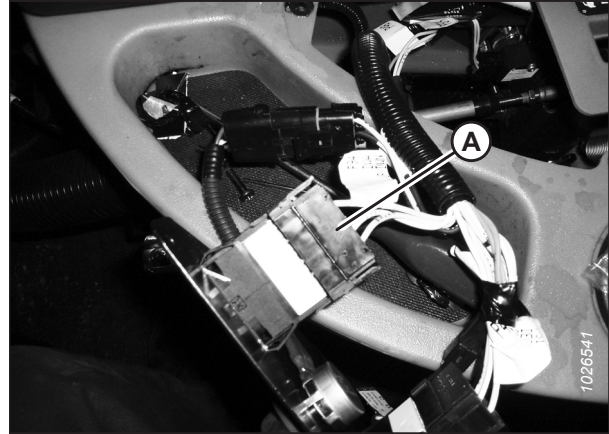

Figure 2.43: Rocker Switch

5. Reinstall cover (A) with five screws (B).

NOTE:

Refer to [3.1 Activating Swath Compressor, page 33](#) to program the cab display module for control of swath compressor functions.

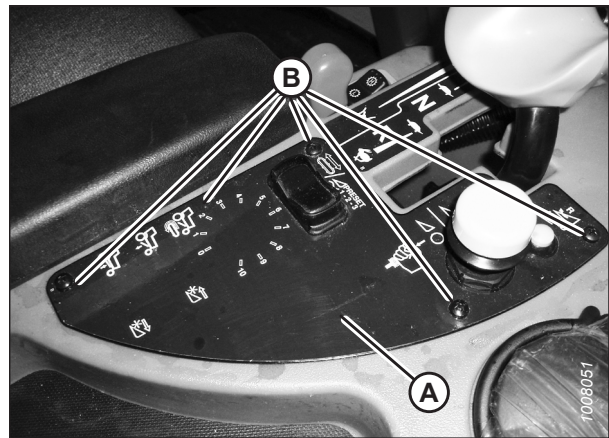

Figure 2.44: Console Control Plate

2.2.6 Installing Shield Assembly

The shield assembly attaches to the swath compressor frame.

⚠ DANGER

To prevent bodily injury or death from the unexpected startup of the machine, stop the engine and remove the key from the ignition before leaving the operator's seat.

⚠ DANGER

Ensure that all bystanders have cleared the area.

INSTALLATION INSTRUCTIONS

1. Clear all bystanders from the area.
2. Start the engine and raise the header legs. Press SWATH COMPRESSOR LOWER switch (A) to fully retract the swath compressor cylinder.
3. Shut down the engine, and remove the key from the ignition.

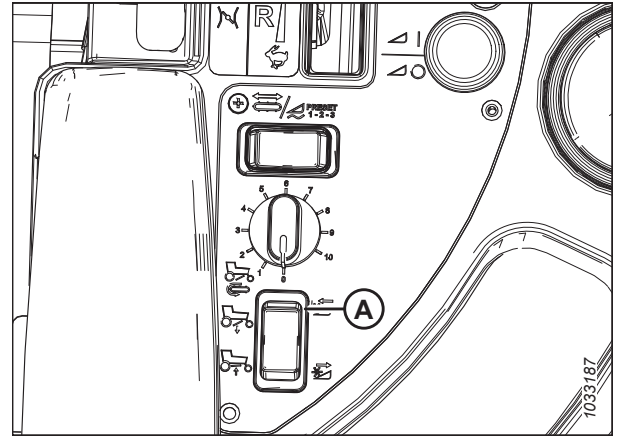

Figure 2.45: Windrower Console Switches

4. Position the forklift with its forks over the front of the compressor shield, and attach lifting straps (A) through the front and the back of the shield frame. Lift the swath compressor shield out of its shipping crate.

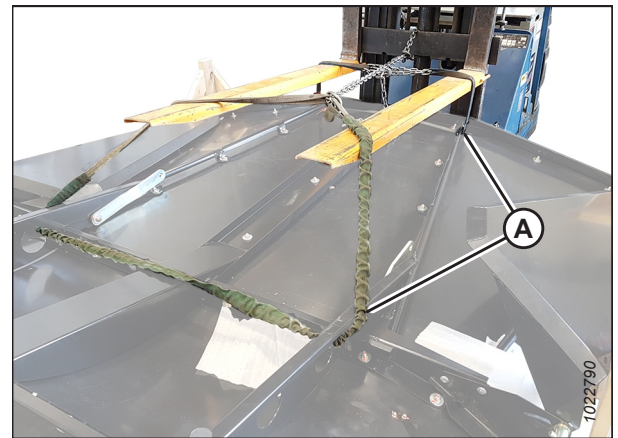

Figure 2.46: Lifting Swath Compressor Shield

5. Approach the windrower from the front and move shield (A) under the windrower. Lower it to the ground. Remove the lifting straps and back the forklift clear of the windrower.

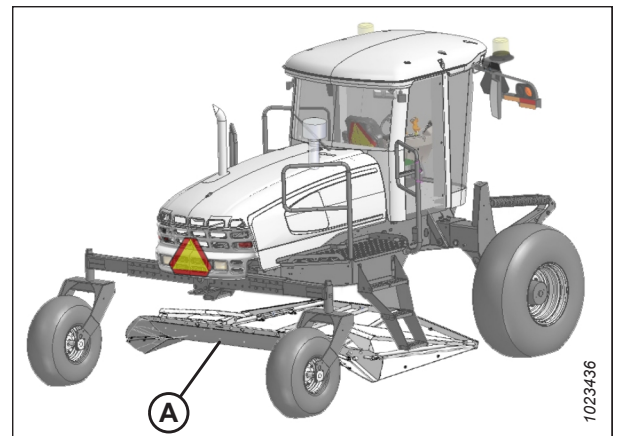

Figure 2.47: Compressor Shield under the Windrower

INSTALLATION INSTRUCTIONS

6. To make connecting the lowering arms easier, turn lock handle (A) counterclockwise and rotate rock shaft (B) so that the supports are vertical.

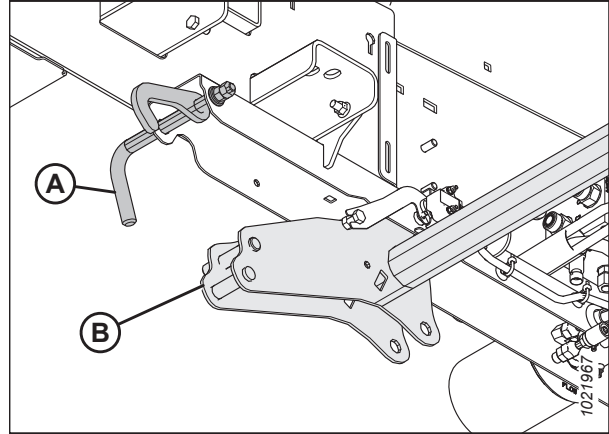

Figure 2.48: Rock Shaft and Lock

7. Ensure bushings (A) are installed onto pins (B) on both sides of the rock shaft.
8. Position the floor jack or equivalent under swath compressor shield cross member (C).
9. Raise the shield sufficiently to connect lowering arm (D) to pin (B) on rock shaft (G).
10. Secure lowering arm (D) to rock shaft (G) with washer (E) and lynch pin (F). Repeat on the opposite side.

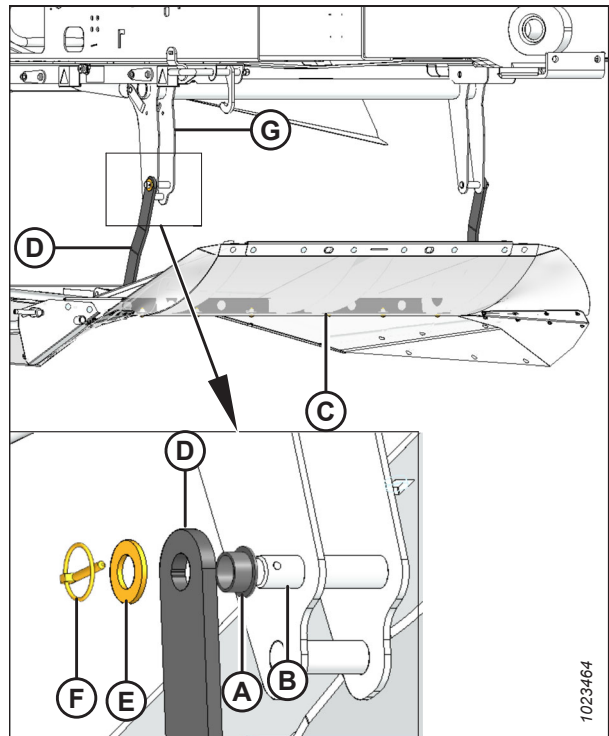

Figure 2.49: Shield Installation

INSTALLATION INSTRUCTIONS

11. Loosen handle (A) and remove three bolts and nuts (B) from side deflector (C). Retain the hardware.

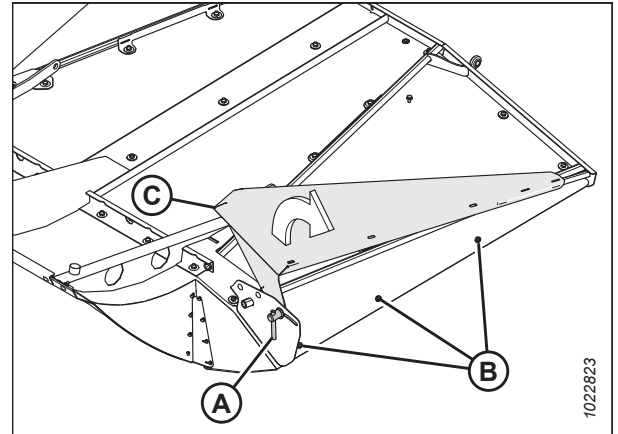

Figure 2.50: Side Deflector Shipping Position

12. Rotate side deflector (A) into working position, and secure it to the compressor shield with three retained bolts and nuts (B) from the previous step. Install the bolts with their heads facing the crop.
13. Torque nuts (B) to 22 Nm (195 lbf-in).
14. Position the side deflector and tighten adjustment handle (C). Repeat on the opposite side.

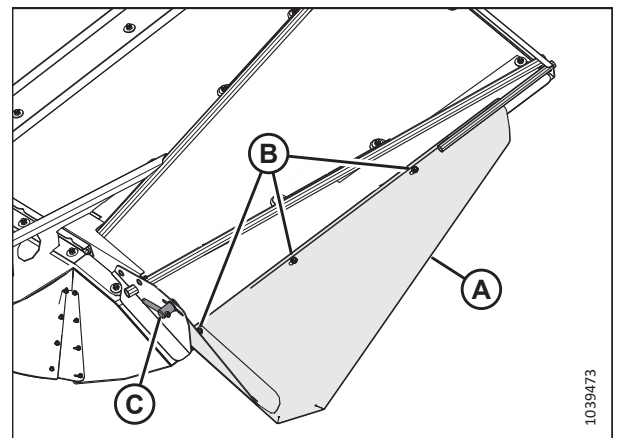

Figure 2.51: Side Deflector Working Position

15. Push rear side (A) of the shield down while another installer lifts shield's front side (D).
16. Align ball joints (C) with pins (B) at the front of the shield, and insert pins (B). Use a rubber mallet if the pins are difficult to install.

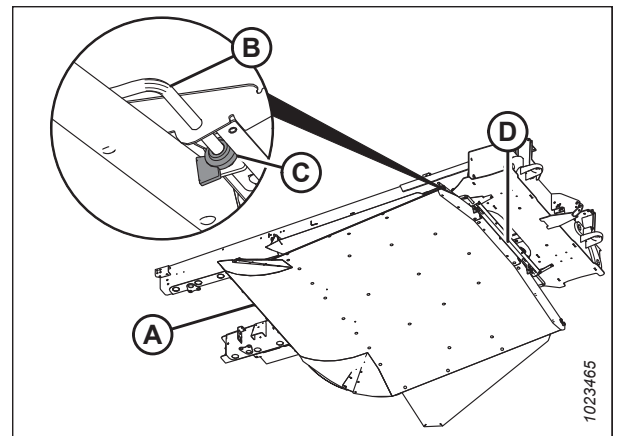

Figure 2.52: Front Pivot Pins

INSTALLATION INSTRUCTIONS

17. Install hairpin (A) to secure pivot pin (B). Repeat on the opposite side.

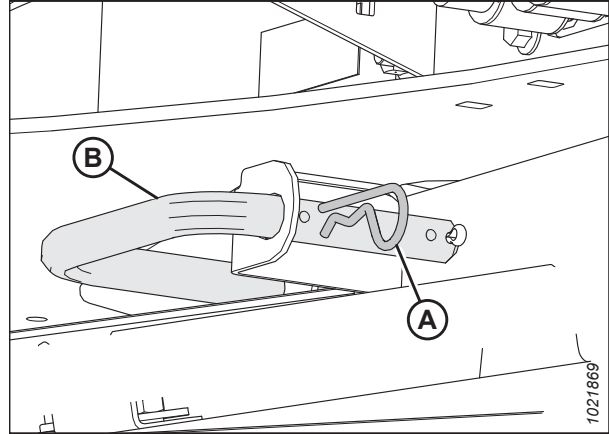

Figure 2.53: Front Pivot Pins

18. Align the rod end of hydraulic cylinder (A) with the holes in the rock shaft and secure with pin (B). Ensure the plate on the pin engages slot (E) in the rock shaft support.
19. Secure the pin with washer (C) and lynch pin (D).

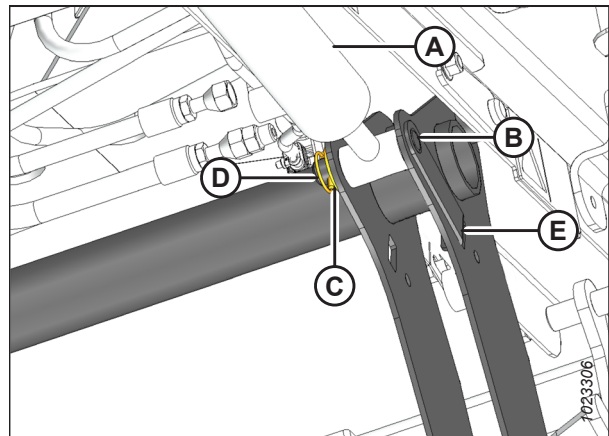

Figure 2.54: Rock Shaft

20. Position front deflector (A) onto front support (B) and remove two existing bolts (C). Do **NOT** discard bolts (C).
21. Secure deflector (A) to the support with two M10 hex head bolts (C) retained from the previous step, and four M10 hex head bolts (D) that secured the deflector to the frame for shipping purposes. Center the deflector to the main shield before tightening the bolts.

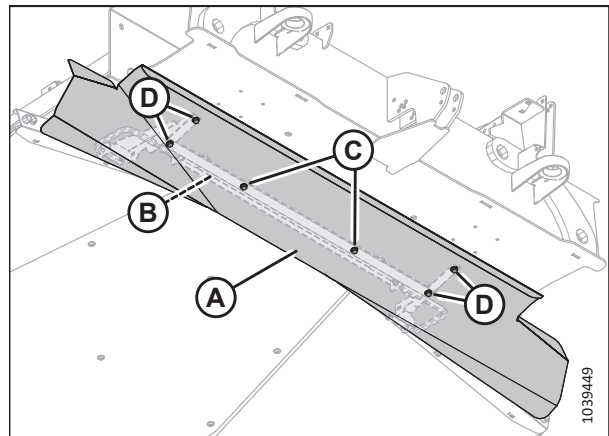

Figure 2.55: Front Deflector – View from below the Shield

OPERATION

8. Press right arrow (A) to scroll through choices until SWATH COMPR HT appears. Press SELECT (B).
 - SWATH SENSOR CAL appears on the upper line.
 - SWATH UP TO START appears on the lower line.

9. Press switch (A) on the console to raise the swath compressor.
 - CALIBRATING SWATH appears on the upper line.
 - The messages FORM UP and HOLD (HOLD will be flashing) appear, and will remain on the lower line until the system has received a signal from the fully-raised swath compressor.
 - The messages SWATH FORM UP and DONE (accompanied by a buzzer tone) will appear on the lower line when the calibration procedure is complete.
 - SWATH SENSOR CAL appears on the upper line.
 - PRESS SWATH DOWN appears on the lower line.

10. Press switch (B) on the console to lower the swath compressor.
 - CALIBRATING SWATH appears on the upper line.
 - The messages FORM DOWN and HOLD appear on the lower line.
 - SWATH FORM COMPLETE flashes for two seconds on the lower line (accompanied by a buzzer tone) when the calibration procedure is complete.

11. Press PROGRAM (A) to exit programming mode or press SELECT (B) to proceed to the next windrower setup option.

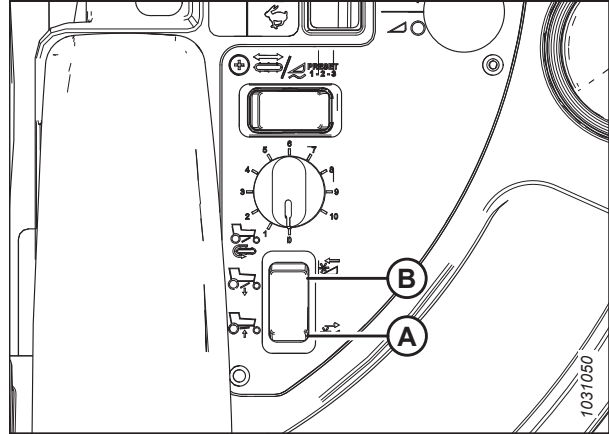

Figure 3.3: Swath Compressor Switch

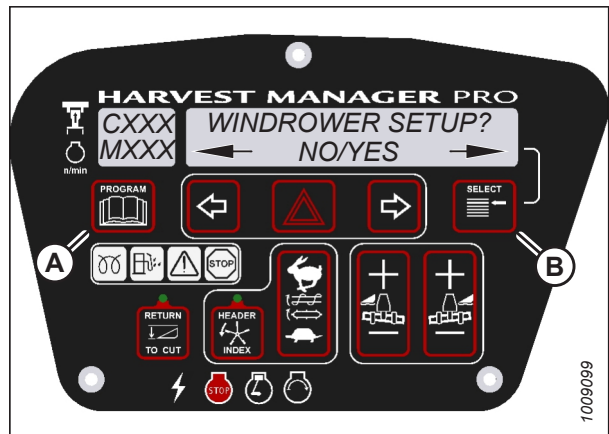

Figure 3.4: CDM Programming Buttons

3.2 Using Swath Compressor

The swath compressor's height can be changed using the button on the operator's console. The height setting can be viewed on the cab display module (CDM).

DANGER

To prevent injury or death from the unexpected start-up of the machine, always stop the engine and remove the key from the ignition before leaving the operator's seat for any reason.

1. To disengage the lock, rotate handle (A) on the left rear support counterclockwise.

IMPORTANT:

- The lock prevents the swath compressor from falling inadvertently when it is not in use.
- Engage the lock when operating the windrower in engine-forward mode.
- Disengage the lock before using the swath compressor for field work.

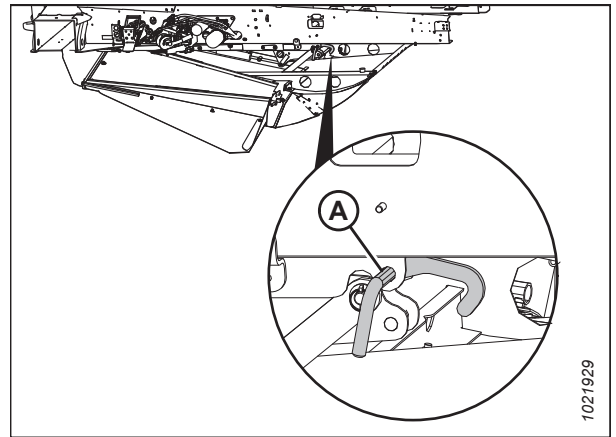

Figure 3.5: Swath Compressor Lock

DANGER

Ensure that all bystanders have cleared the area.

2. Start the windrower.
3. Ensure that the windrower is in cab-forward mode.
4. Press SELECT switch (B) on the cab display module (CDM) to show SWATH COMPR HT (A) on the display. The height is displayed using a scale from 0 to 10, where 0 indicates that the swath compressor is fully raised, and 10 indicates that it is fully lowered.

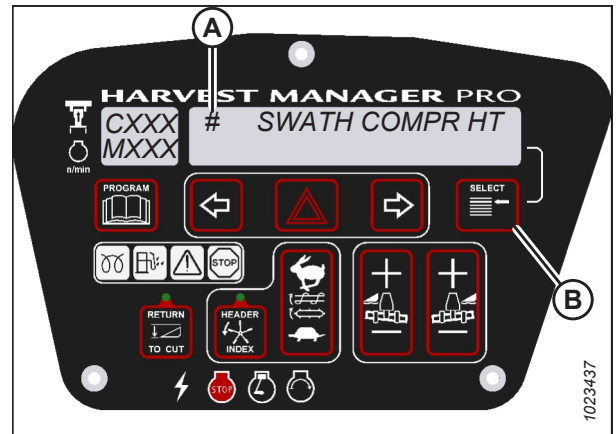

Figure 3.6: CDM Display

OPERATION

- Lower the swath compressor by pressing button (A) on the operator's console; raise it by pressing button (B). The CDM display indicates the height of the swath compressor. When the swath compressor is at the desired height, release the switch to stop the swath compressor's movement.

NOTE:

When button (A) is pressed, the CDM will display the new target swath compressor height value for 5 seconds, after which the actual height of the swath compressor will be displayed again.

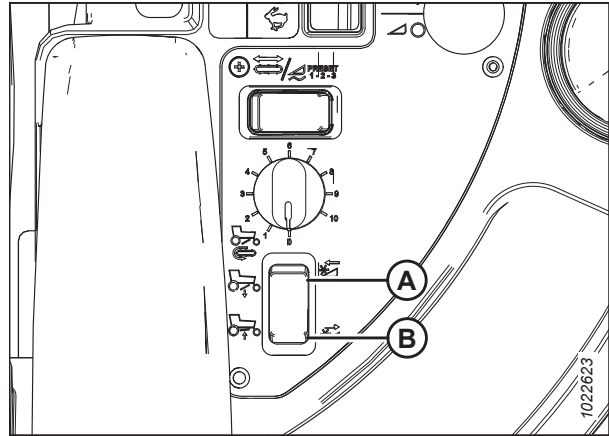

Figure 3.7: Operator's Console

The swath compressor system has several automated features:

- When the windrower's ground speed is greater than 2.5 km/h (1.6 mph), the swath compressor falls to the target height.
- When the windrower's speed falls below 1.6 km/h (1 mph), the swath compressor will rise to its maximum height.
- When the windrower's ground speed is greater than 1.6 km/h (1 mph) and the HEADER ENGAGE switch is OFF, the swath compressor will rise fully.
- The swath compressor will remain fully raised when the windrower is in engine-forward mode.

3.2.1 Setting up Swath Compressor

Operate the windrower in crop and use the following procedure to determine the settings for the crop and crop conditions.

CAUTION

Park on a level surface with the ground speed lever (GSL) in the N-DETENT position and the steering wheel in the locked (centered) position. Wait for the cab display module (CDM) to beep and display an "In Park" message to confirm that the parking brake is engaged.

DANGER

To prevent bodily injury or death from the unexpected startup of the machine, stop the engine and remove the key from the ignition before leaving the operator's seat.

DANGER

Ensure that all bystanders have cleared the area.

OPERATION

1. Rotate handle (A) counterclockwise to disengage the lock on the left rear support.
2. Clear all bystanders from the area.
3. Start the engine, set ground speed lever (GSL) in N-DETENT, and ensure that the header is disengaged.

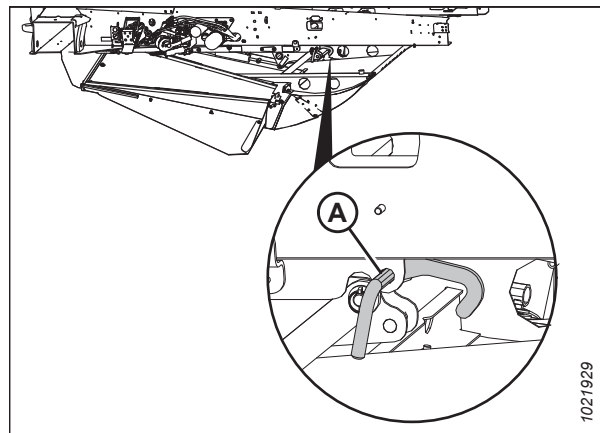

Figure 3.8: Swath Compressor Lock

4. Adjust the swath compressor position to the target (or preferred) operating height using controls (A) and (B) on the console. Set the target operating height to 6 if there is no preferred operating height.
5. Engage and then disengage the header. The swath compressor will raise fully.

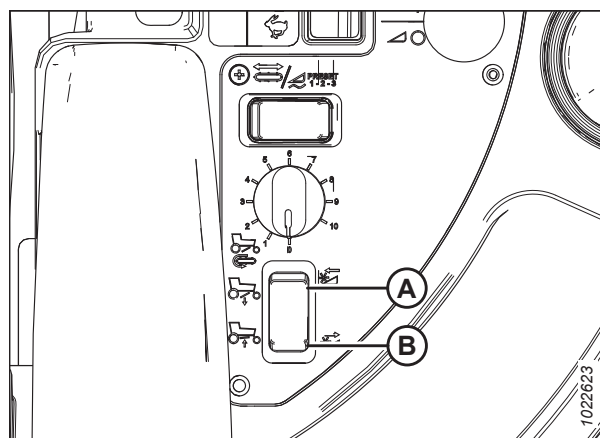

Figure 3.9: Operator's Console

6. Engage the header and begin cutting crop. When the ground speed exceeds 2.5 km/h (1.6 mph), the swath compressor will lower to target (or preferred) height (A).
7. Shut down the engine, and remove the key from the ignition.
8. Check the formation of the windrow.
 - If necessary, adjust target height (A).
 - If the edges of the windrow are not sufficiently pressed into the stubble, adjust the side deflectors. For instructions, refer to [3.2.3 Adjusting Side Deflectors, page 38](#).
 - If the swath compressor shield raises too easily in dense windrows, adjust the compression. For instructions, refer to [3.2.2 Adjusting Compression, page 38](#).

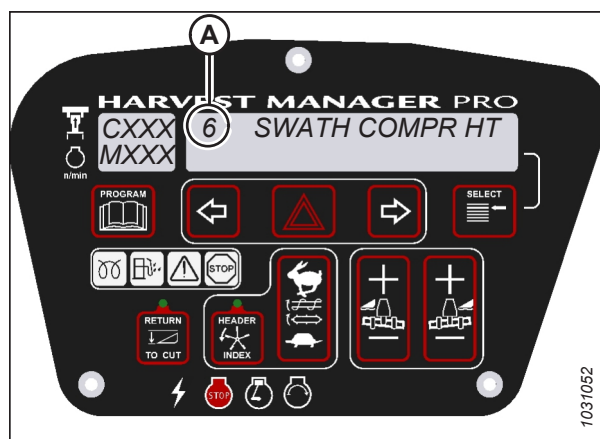

Figure 3.10: Display

3.2.2 Adjusting Compression

The swath compressor automatically raises when the load on the shield exceeds the compression setting. When load decreases, the compressor deck automatically returns to the target height.

The compression setting is set at the factory to suit most crop conditions and can be adjusted as follows:

1. Loosen jam nut (A) to allow adjustment knob (B) to turn. Do **NOT** remove the nut.
 - For a more compact windrow with higher wind resistance, turn adjuster knob (B) clockwise to increase cut crop compression.
 - To minimize crop shelling and decrease cut crop compression, turn adjuster knob (B) counterclockwise.

NOTE:

Start with the lowest compression (with the adjuster knob fully turned counterclockwise) and increase the compression setting in 1/2 turn increments as required.

2. Tighten jam nut (A) sufficiently to maintain the setting.

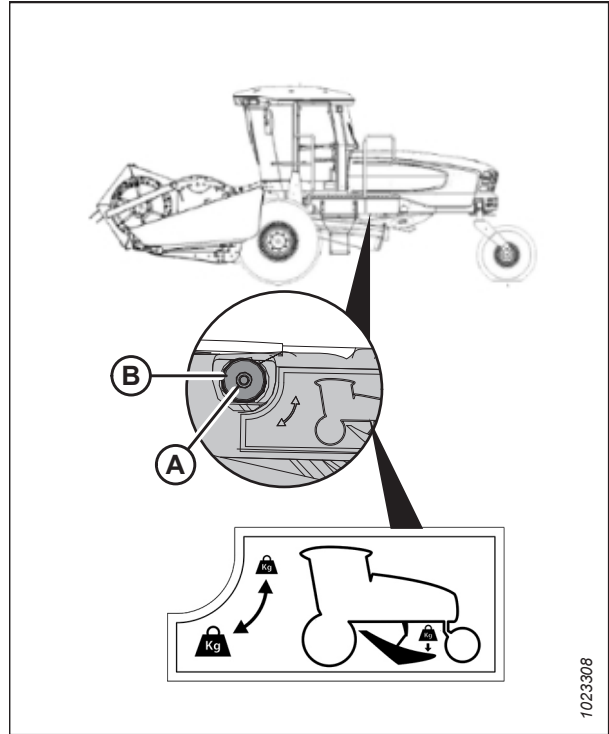

Figure 3.11: Compression Adjustment

3.2.3 Adjusting Side Deflectors

To reduce wind damage to the windrow, adjust the side deflectors to ensure the edges of the windrows are tucked in and anchored to the stubble.

1. To adjust swath compressor side deflectors (A), loosen handles (B) and move the deflectors to the desired position. To ensure that the windrow placement is centered, set both side deflectors to the same position.
2. Tighten handles (B) when the adjustment is complete.

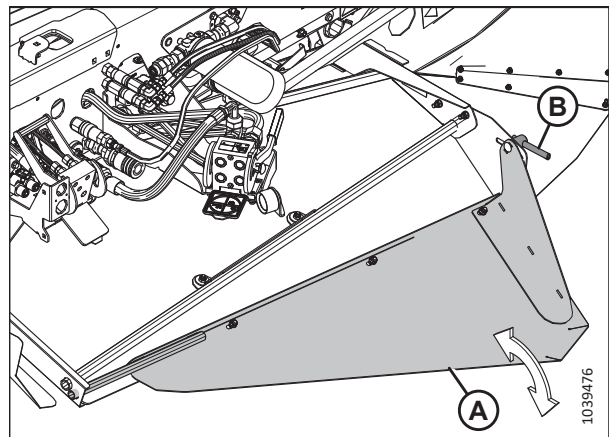

Figure 3.12: Swath Compressor Side Deflectors

3.2.4 Locking and Unlocking Swath Compressor

The swath compressor lock is located on the left cab-forward side of the swath compressor frame. When engaged, the lock prevents the compressor shield from lowering.

1. Turn lock handle (A) clockwise to engage the swath compressor lock under the following conditions:
 - Swath compressor is not in use
 - Windrower is being serviced
 - Windrower is in engine-forward mode
2. Turn handle (A) counterclockwise to disengage the lock before operating the swath compressor.

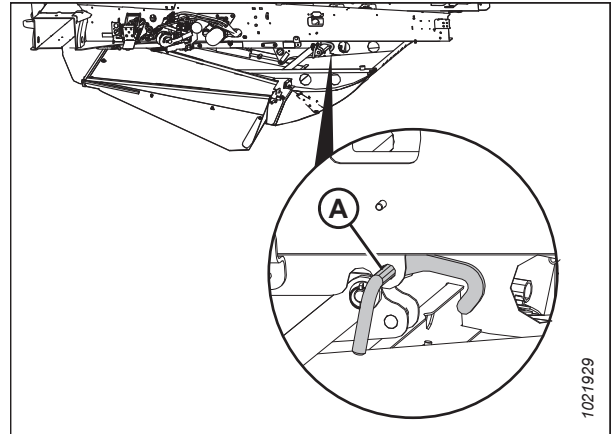

Figure 3.13: Swath Compressor Lock

Chapter 4: Maintenance

The swath compressor does not require any scheduled maintenance or servicing.

If it's necessary to replace components, refer to *5 Illustrated Parts Lists, page 43* in this manual.

4.1 Removing Swath Compressor Shield

Windrower service or maintenance procedures may require access under the machine.

DANGER

To prevent bodily injury or death from the unexpected startup of the machine, stop the engine and remove the key from the ignition before leaving the operator's seat.

DANGER

Ensure that all bystanders have cleared the area.

Do **NOT** sit on the swath compressor shield to service the windrower. Remove the shield as follows:

1. Clear all bystanders from the area.
2. Disengage swath compressor lock (A).
3. Start the windrower and fully lower the swath compressor.
4. Shut down the engine, and remove the key from the ignition.

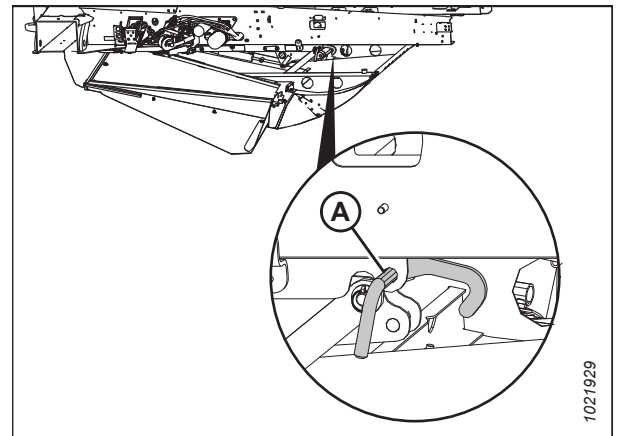

Figure 4.1: Swath Compressor Lock

5. At the front of the swath compressor, remove hairpin (A) from pivot pin (B) on both sides of the frame.

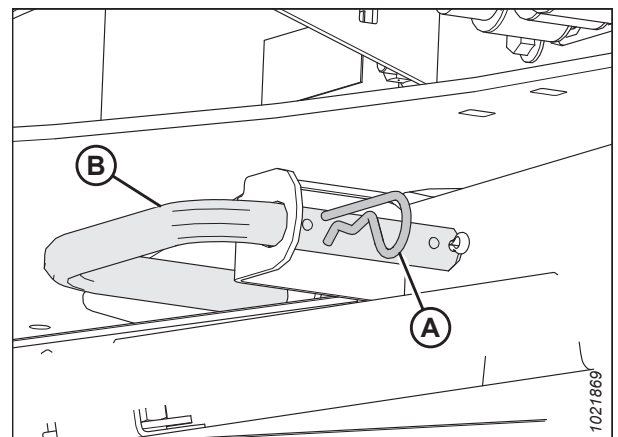

Figure 4.2: Forward Pivot Pin

MAINTENANCE

6. Push down on shield's rear side (A) while another person supports front side (D). Pull pivot pins (B) from ball joints (C) on both sides of the frame. To avoid misplacing the parts, reinstall the hairpins into the pivot pins.
7. Lower the front end of the shield to the ground.

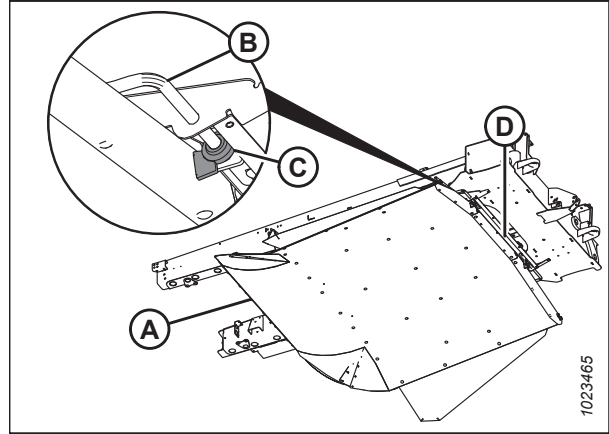

Figure 4.3: Front Pivot Pins

8. Support the shield under support (C) at the back end with a floor jack (or equivalent).
9. Remove lynch pins (F) and washers (E) from pins (B) on both ends of rock shaft (G).
10. Remove lowering arms (D) from rock shaft (G).
11. Store bushings (A), washers (E) and lynch pins (F) on pins (B).
12. Lower the back end of the shield to the ground and move the jack away from the work area.
13. Start the windrower and fully raise the swath compressor lift mechanism. Slowly drive the windrower away from the shield.

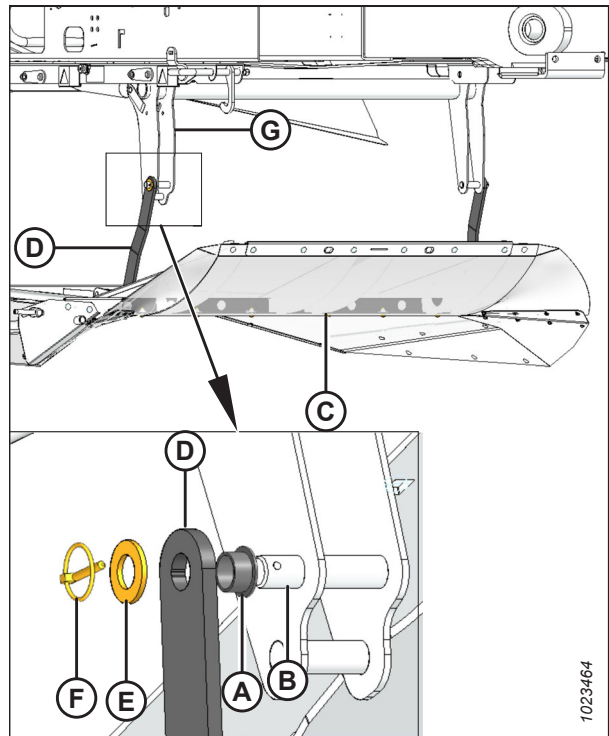

Figure 4.4: Disconnecting Lowering Arms

Chapter 5: Illustrated Parts Lists

This section lists the replacement parts for the M Series Windrower and Swath Compressor.

Bold text is used to indicate updates made at the current revision level. With each new revision of the manual, previous revisions are returned to regular text.

ILLUSTRATED PARTS LISTS

5.1 Abbreviations

A/R – as required (quantity varies)	ASSY – assembly	BHRN – button head rib neck
BV – ball valve	CCW – counterclockwise	CON – conical (spring washer)
CSK – countersink	C/W – complete with	CW – clockwise
DBLE – double	DK – double knife	DR – double reel
DT – distorted thread	FLG – flange	GA – gauge
GR – grade	GS – grass seed	HD – head
HDR – header	HFA – hydraulic fore-aft	HH – hex head
HNBR – hydrogenated nitrile butadiene rubber	HYD – hydraulic	I.D. – inside diameter
IP – internal plus (torx plus)	KP – knife pressure	KR – knife return
LG – long	LH – left hand (determined from Operator's position, facing forward)	LK – lock
MACH – machine	MD – MacDon	MFA – manual fore-aft
MY – model year	NC – national coarse thread	NF – national fine thread
NSS – not sold separately	NT – narrow transport	O.D. – outside diameter
OPT – optional	PO – pilot operated	PT – pull-type (mower conditioner)
RC – roller chain	REF – reference, part number called up elsewhere in catalog	REG – regular
RH – right hand (determined from Operator's position, facing forward)	RHSN – round head, square neck or square neck carriage bolt	RHSSN – round head, short, square neck
RTD – rotating tine drum	SAE – Society of Automotive Engineers (part produced to comply with)	SD – side draper
SER – serrated	SK – single knife	SKT HD – socket head
SMTH – smooth	SMV – slow moving vehicle	SOCK – socket
SP – self-propelled (windrower) header	SPCL – special	SPH – spherical
SPI – serrations per inch (knife Sections)	SR – single reel	STL – steel (stainless)
STR – standard	STVR – Stover	TFL – thread full length
THD – thread	TR – triple reel	UCA – upper cross auger
UDK – untimed double knife	UNC – unified coarse thread	UNEF – unified extra fine thread
UNF – unified fine thread	UNS – unified special thread series	VK – vertical knife
WF – wide frame	ZP – zinc plated	

5.2 Serial Number Breaks

The side of the serial number on which the dash (-) appears determines whether the part is used "up to" or "after" the serial number given.

Example:

- -451189 Used on machines up to and including serial number 451189
- 451190- Used on machines including and after serial number 451190

5.3 Swath Compressor Shield Assembly

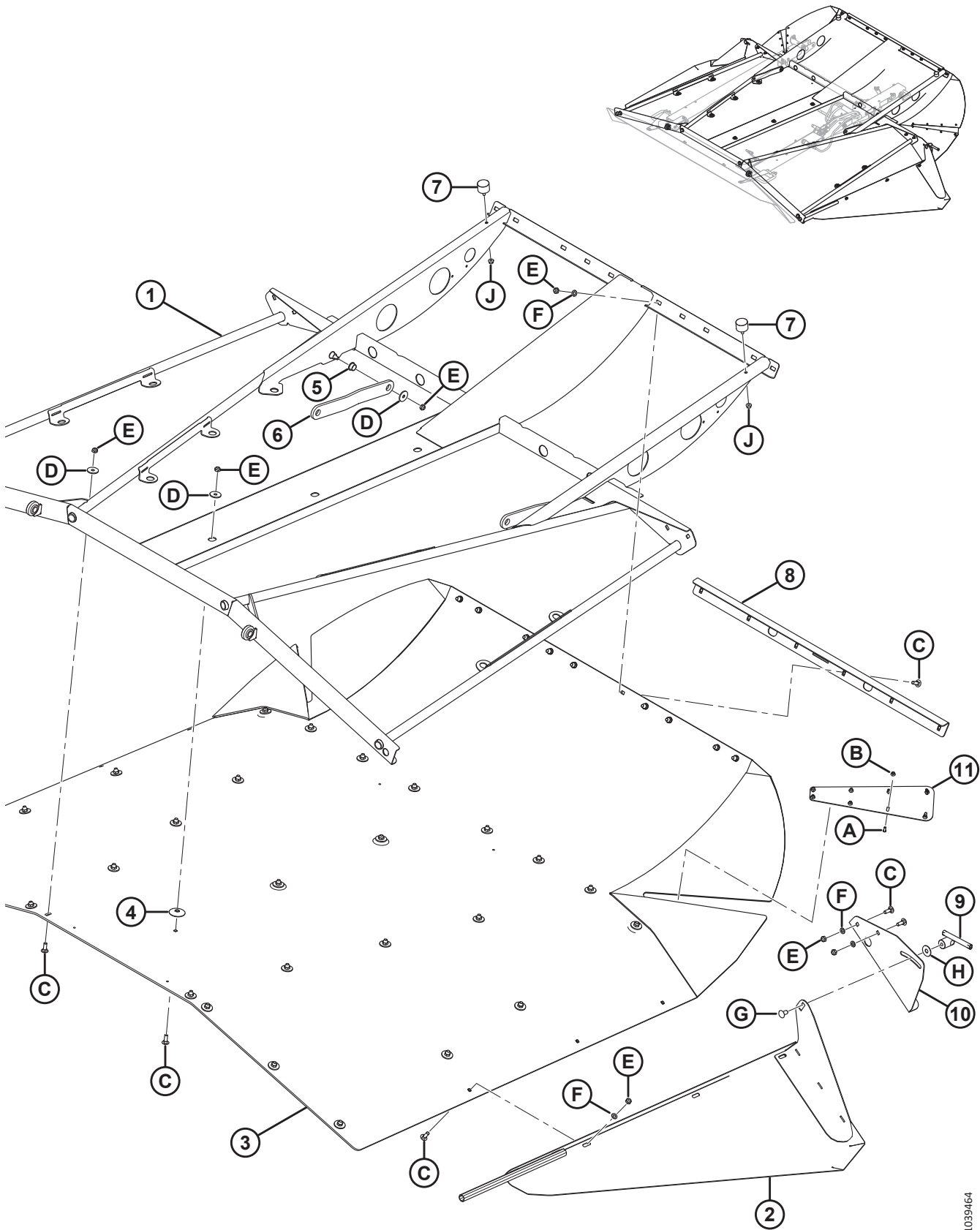

1039464

ILLUSTRATED PARTS LISTS

Ref	Part Number	Description	Qty	Serial Number
1	306660	SUPPORT – DEFLECTORS, WELDMENT	1	
2	306661	DEFLECTOR – LH WELDMENT	1	
	306662	DEFLECTOR – RH WELDMENT	1	
3	277323	SHEET – SWATH COMPRESSOR	1	
4	128697	DISC – RETAINER	21	
5	128737	BUSHING – FLANGE	2	
6	128729	ARM – LOWER	2	
7	203350	BUMPER – RUBBER	2	
8	128740	ANGLE – REAR TOP	1	
9	247693	ASSEMBLY – HANDLE	2	
10	277405	SUPPORT – REAR DEFLECTOR, LH	1	
	277414	SUPPORT – REAR DEFLECTOR, RH	1	
11	277409	STRAP – JOINING	2	
A	191393	SCREW – HEX SOC BTN HD M6 X 1 X 20-12.9-AFOC		
B	152668	NUT – HEX FLG CTR LOC M6 X 1-8-AA1J		
C	252872	SCREW – FLG BTN HD M10 X 1.5 X 30-10.9-AA1J		
D	16652	WASHER – FLAT		
E	184692	NUT – HEX NYLOC M10 X 1.5-8-AA1J		
F	184711	WASHER – FLAT REG M10-200HV-AA1J		
G	152439	BOLT – RHSSN M12 X 1.75 X 25-8.8-AA1J		
H	32247	WASHER – FLAT		
J	135337	NUT – HEX FLG CTR LOC M8 X 1.25-8-AA1J		

5.4 Swath Compressor Hydraulics and Supports

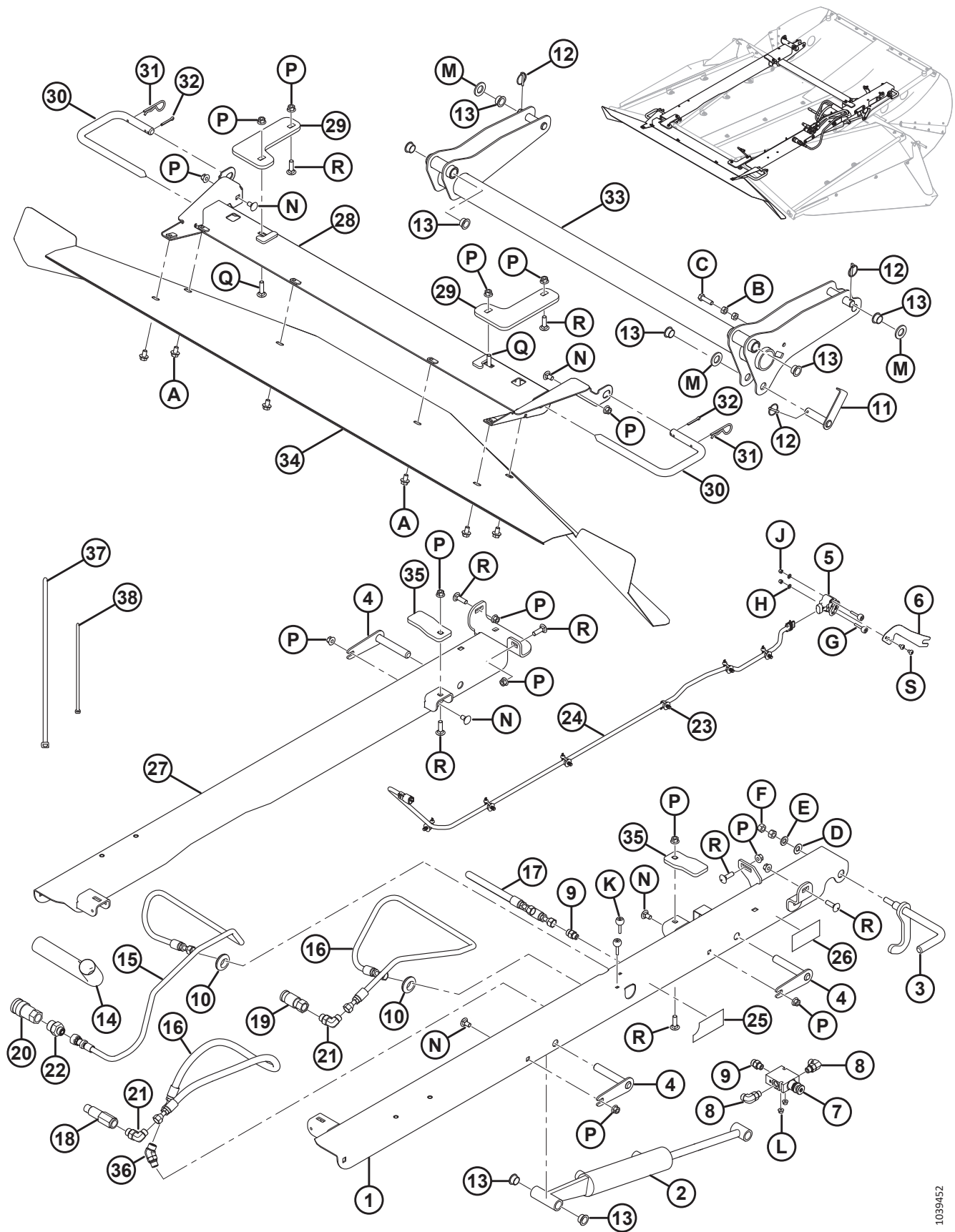

1039452

ILLUSTRATED PARTS LISTS

Ref	Part Number	Description	Qty	Serial Number
1	128780	SUPPORT – LH WELDMENT	1	
2	128764	CYLINDER	1	
3	128768	LEVER – LOCK PIN WELDMENT	1	
4	128788	PIN – PIVOT, WELDMENT	3	
5	128994	ROTARY SENSOR HV	1	
6	128773	ARM – SENSOR	1	
7	128789	VALVE – PRESSURE REDUCING	1	
8	136095	FITTING – ELBOW 90° HYD	2	
9	135778	FITTING – ADAPTER	2	
10	42046	GROMMET	2	
11	277331	PIN – CYLINDER, WELDMENT	1	
12	50193	PIN – LYNCH	3	
13	128737	BUSHING – FLANGE	10	
14	112940	SLEEVE	1	
15	277042	HOSE – HYD, .25 IN. I.D., 1400 MM LG, 100R17, METAL REIN.	1	
16	277041	HOSE – HYD, .25 IN. I.D., 1220 MM LG, 100R17, METAL REIN.	2	
17	232597	HOSE – HYD, .25 IN. I.D., 490 MM LG, 100R17, METAL REIN.	1	
18	135386	COUPLER – MALE HYD. 3/8 IN. FLAT FACE	1	
	111978	SEAL KIT		
19	135312	COUPLER – FEMALE HYD. 3/8 IN. FLAT FACE	1	
20	135474	COUPLER – HYDRAULIC, 1/2 IN. FEMALE FF	1	
21	136149	FITTING – ELBOW 90° HYD CW O-RING	2	
22	136194	FITTING – ADAPTER	1	
23	136655	FASTENER – FIR TREE MT W/ TIE	6	
24	209256	HARNESS – SWATH COMPRESSOR	1	
25	128973	DECAL – DOWN FORCE	1	
26	291638	DECAL – DECK LOWER LOCK	1	
27	128781	SUPPORT – RH WELDMENT	1	
28	128762	SUPPORT – FRONT PIVOT, WELDMENT	1	
29	128776	BAR – CLAMP	2	
30	128756	PIN – PIVOT	2	
31	13125	PIN – HAIR	2	
32	18648	PIN – COTTER 3/16 DIA X 1.25 ZP	2	
33	128770	ROCKSHAFT – LIFT, WELDMENT	1	
34	310620	DEFLECTOR – FRONT	1	
35	277435	BAR – CLAMP	2	
36	136144	FITTING – ELBOW 45° HYD	1	
37	30753	FASTENER – CABLE TIE, BLACK, 305 MM LG ¹	2	
38	21763	FASTENER – CABLE TIE, BLACK, 160 MM LG ¹	1	
A	136151	BOLT – HEX FLG HD TFL M10 X 1.5 X 16-8.8-AA1J		
B	30505	NUT – HEX M10 X 1.5-10-AA1J		
C	30628	BOLT – HEX HD M10 X 1.5 X 35-8.8-AA1J		

1. Shipped in manual bag.

ILLUSTRATED PARTS LISTS

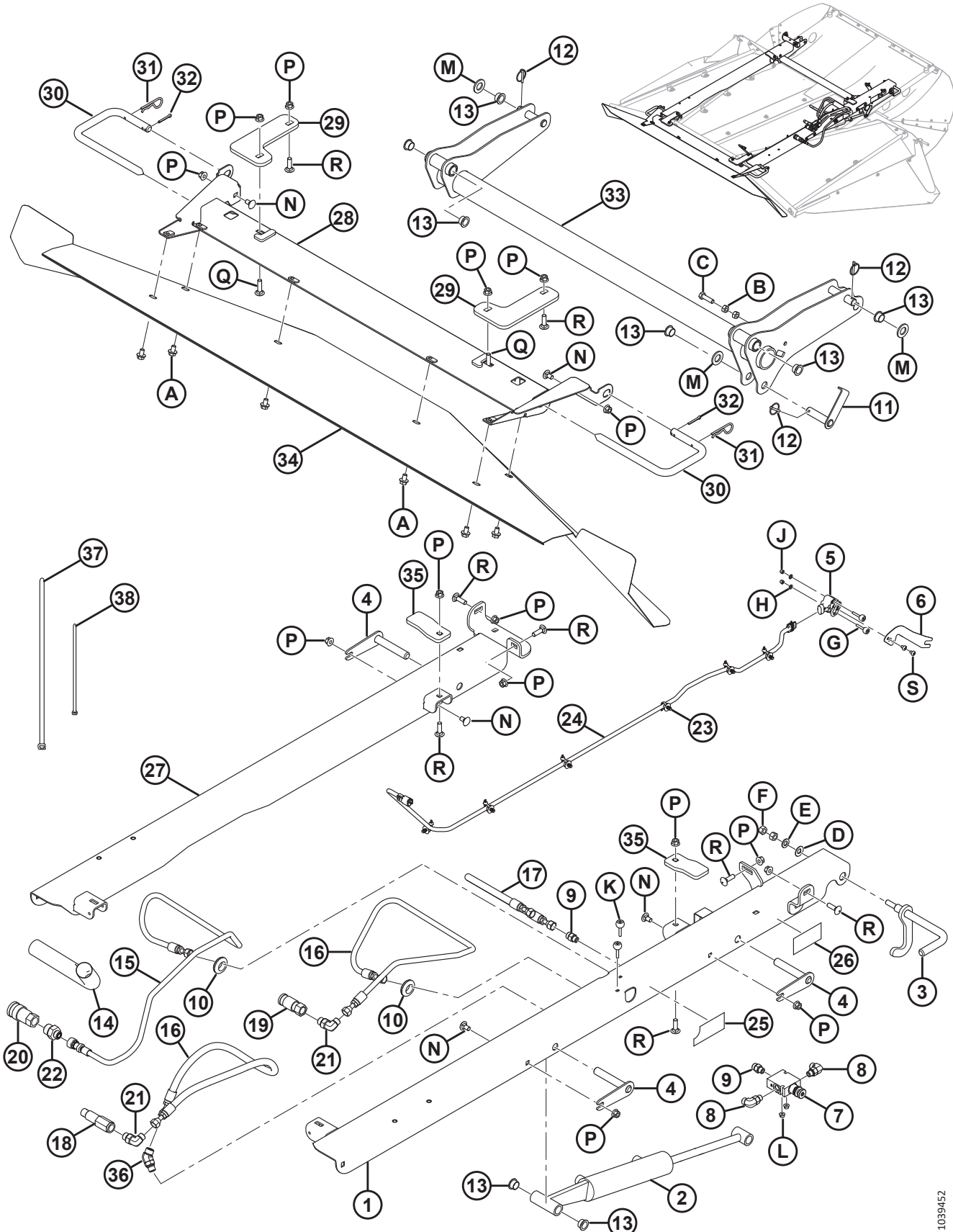

1039452

ILLUSTRATED PARTS LISTS

Ref	Part Number	Description	Qty	Serial Number
D	184595	WASHER – CONICAL SPRING 1/2 IN.		
E	184714	WASHER – FLAT REG M12-300HV-AA1J		
F	184694	NUT – HEX M12 X 1.75-8-AA1J		
G	136604	BOLT – RHSN TFL M5 X 0.8 X 40-8.8-AA1J		
H	184701	WASHER – FLAT LARGE M5-200HV		
J	197230	NUT – HEX NYLOC M5 X 0.8-8-AA1J		
K	136731	BOLT – RHSN M6 X 1 X 45-8.8-AA1J		
L	152668	NUT – HEX FLG CTR LOC M6 X 1-8-AA1J		
M	18601	WASHER – SAE FLAT 13/16 I.D. X 1.5 IN. O.D. ZP		
N	136178	BOLT – RHSN M10 X 1.5 X 20-8.8-AA1J		
P	135799	NUT – HEX FLG CTR LOC M10 X 1.5-10-AA1J		
Q	152732	BOLT – RHSN M10 X 1.5 X 40-8.8-AA1J		
R	135691	BOLT – RHSN TFL M10 X 1.5 X 35-8.8-AA1J		
S	252291	SCREW – PAN HD M6 X 1 X 8-8.8-AA1J		

5.4.1 M Series Swath Compressor Completion

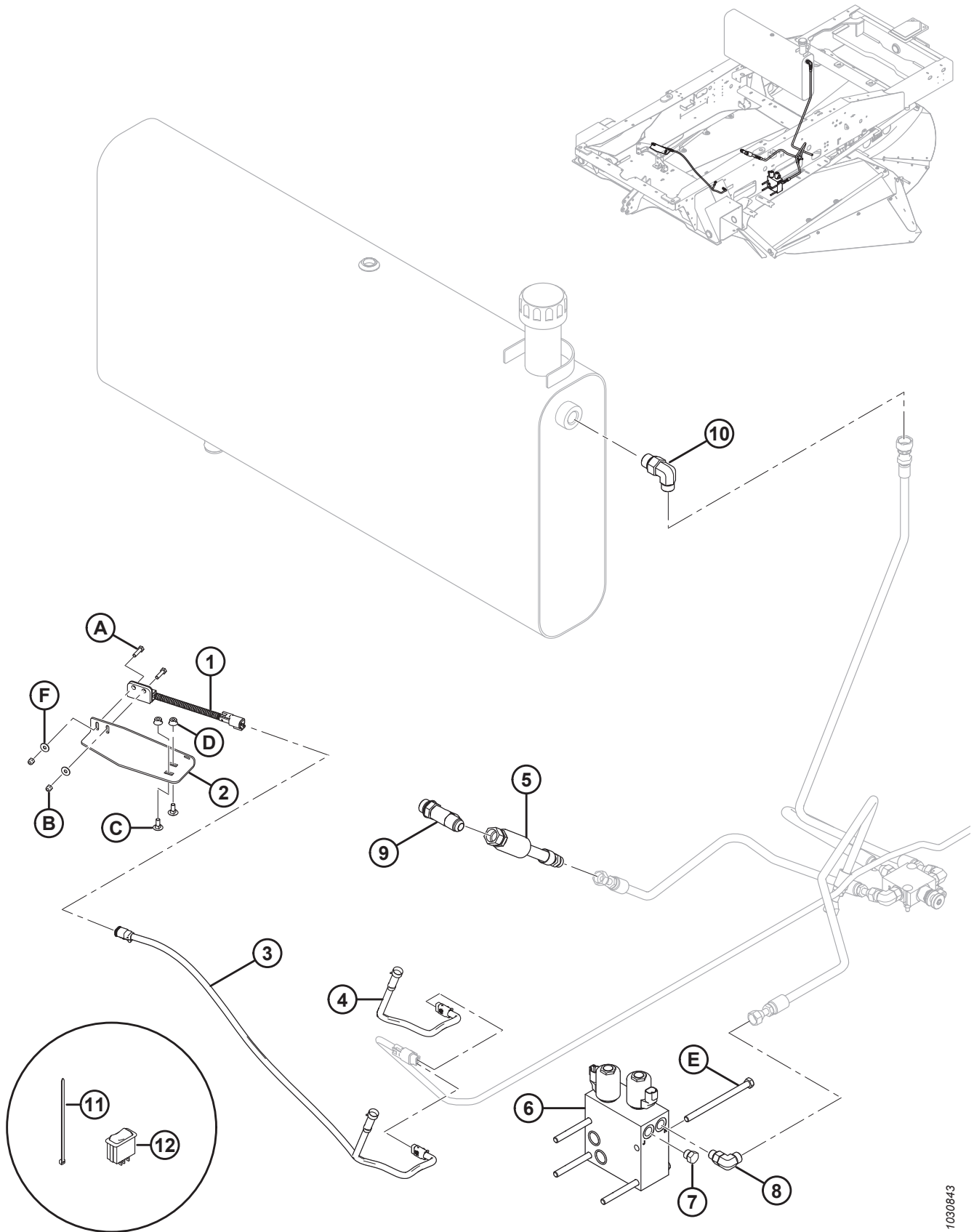

1030843

ILLUSTRATED PARTS LISTS

NOTE:

This supplemental parts list is applicable only to M155, M155E4, and M205 Windrowers.

Ref	Part Number	Description	Qty	Serial Number
1	200974	SWITCH – PROXIMITY	1	
2	128681	SUPPORT – F/R SWITCH	1	
3	128972	HARNESS – 5-SERIES SWATH COMP ²	1	
4	306261	HARNESS – 5-SERIES SWATH COMP ³	1	
5	277043	HOSE – HYD, .375 IN. I.D., 200 MM LG, 100R17, METAL REIN.	1	
6	139974	VALVE BLOCK – AUX LIFT (REEL FORE AFT-DWA)	1	
7	30994	FITTING – PLUG HYD-6 ORB HEX HD	1	
8	136095	FITTING – ELBOW 90° HYD	1	
9	50019	FITTING – TEE HYD	1	
10	135917	FITTING – ELBOW 90° HYD	1	
11	21763	FASTENER – CABLE TIE, BLACK, 160 MM LG	5	
12	109575	SWITCH – ROCKER, ON-OFF-ON	1	
A	184640	BOLT – HEX HD M5 X 0.8 X 20-8.8-AA1J		
B	197230	NUT – HEX NYLOC M5 X 0.8-8-AA1J		
C	136748	BOLT – RHSN M6 X 1 X 16-8.8-AA1J		
D	152668	NUT – HEX FLG CTR LOC M6 X 1-8-AA1J		
E	10948	BOLT – HH 3/8 NC X 5.5 LG GR 5 ZP		
F	184701	WASHER – FLAT LARGE M5-200HV-AA1J		

2. Completion harness (MD #128972) is required for model year 2017 windrowers and prior. If a swath compressor has previously been installed on the windrower using harness (MD #128972) but requires a chassis harness replacement, use harness (MD #306261) to complete the swath compressor installation.
3. Completion harness (MD #306261) is required for model year 2018 windrowers and later.

5.5 Decals

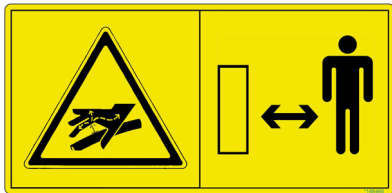
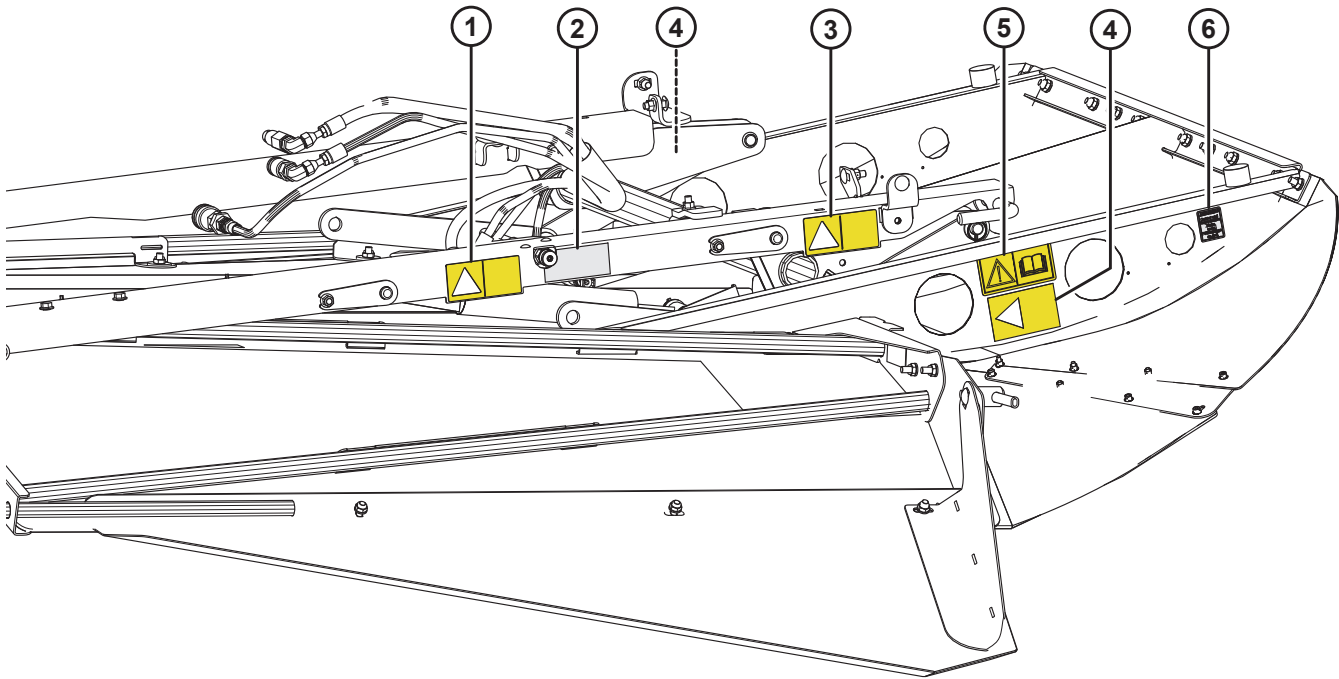

1

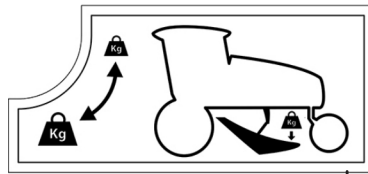

2

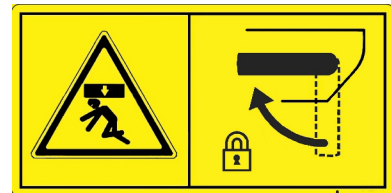

3



4 x2



5

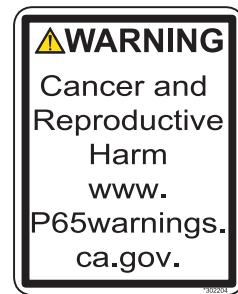

6

ILLUSTRATED PARTS LISTS

Ref	Part Number	Description	Qty	Serial Number
1	166466	DECAL – HIGH PRESSURE FLUID	1	
2	128973	DECAL – DOWN FORCE	1	
3	291638	DECAL – DECK LOWER LOCK ⁴	1	
4	174683	DECAL – PINCH POINT	2	
5	184372	DECAL – READ MANUAL	1	
6	302204	DECAL – CA PROPOSITION 65	1	

4. May not be exactly as shown.

Chapter 6: Reference

The reference chapter provides additional information such as the torque specification and a unit conversion chart.

6.1 Torque Specifications

The following tables provide torque values for various bolts, cap screws, and hydraulic fittings. Refer to these values only when no other torque value has been specified in a given procedure.

- Tighten all bolts to the torque values specified in the charts below, unless you are directed otherwise in this manual.
- Replace removed hardware with hardware of the same strength and grade.
- Refer to the torque value tables as a guide when periodically checking the tightness of bolts.
- Understand the torque categories for bolts and cap screws by reading the markings on their heads.

Jam nuts

Jam nuts require less torque than nuts used for other purposes. When applying torque to finished jam nuts, multiply the torque applied to regular nuts by 0.65 to obtain the modified torque value.

Self-tapping screws

Refer to the standard torque values when installing the self-tapping screws. Do **NOT** install the self-tapping screws on structural or otherwise critical joints.

6.1.1 SAE Bolt Torque Specifications

The torque values provided in the following SAE bolt torque tables apply to hardware installed dry; that is, hardware with no grease, oil, or threadlocker on the threads or heads. Do **NOT** grease or oil bolts or cap screws unless directed to do so in this manual.

Table 6.1 SAE Grade 5 Bolt and Grade 5 Free Spinning Nut

Nominal Size (A)	Torque (Nm)		Torque (lbf·ft) (*lbf·in)	
	Min.	Max.	Min.	Max.
1/4-20	11.9	13.2	*106	*117
5/16-18	24.6	27.1	*218	*241
3/8-16	44	48	32	36
7/16-14	70	77	52	57
1/2-13	106	118	79	87
9/16-12	153	170	114	126
5/8-11	212	234	157	173
3/4-10	380	420	281	311
7/8-9	606	669	449	496
1-8	825	912	611	676

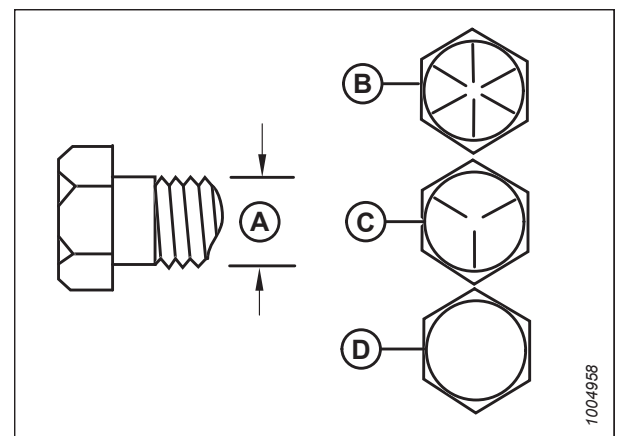

Figure 6.1: Bolt Grades

A - Nominal Size
C - SAE-5

B - SAE-8
D - SAE-2

REFERENCE

Table 6.2 SAE Grade 5 Bolt and Grade F Distorted Thread Nut

Nominal Size (A)	Torque (Nm)		Torque (lbf-ft) (*lbf-in)	
	Min.	Max.	Min.	Max.
1/4-20	8.1	9	*72	*80
5/16-18	16.7	18.5	*149	*164
3/8-16	30	33	22	24
7/16-14	48	53	35	39
1/2-13	73	80	54	59
9/16-12	105	116	77	86
5/8-11	144	160	107	118
3/4-10	259	286	192	212
7/8-9	413	456	306	338
1-8	619	684	459	507

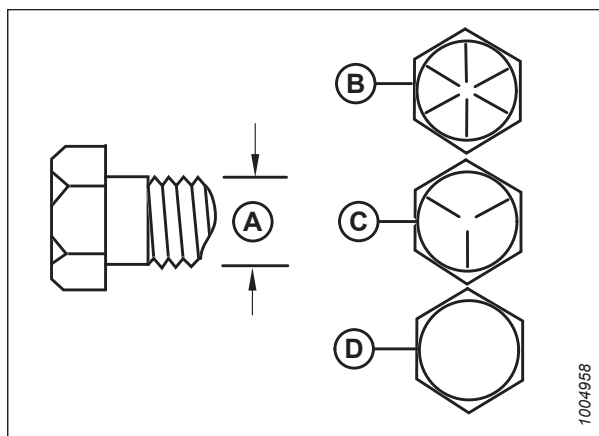

Figure 6.2: Bolt Grades

A - Nominal Size
 C - SAE-5
 B - SAE-8
 D - SAE-2

Table 6.3 SAE Grade 8 Bolt and Grade G Distorted Thread Nut

Nominal Size (A)	Torque (Nm)		Torque (lbf-ft) (*lbf-in)	
	Min.	Max.	Min.	Max.
1/4-20	16.8	18.6	*150	*165
5/16-18	24	26	18	19
3/8-16	42	46	31	34
7/16-14	67	74	50	55
1/2-13	102	113	76	84
9/16-12	148	163	109	121
5/8-11	204	225	151	167
3/4-10	362	400	268	296
7/8-9	583	644	432	477
1-8	874	966	647	716

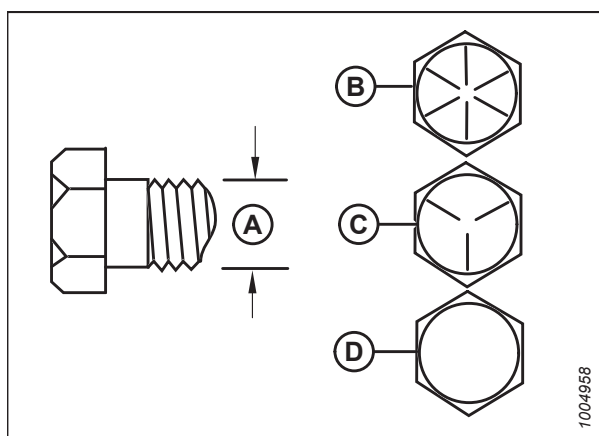

Figure 6.3: Bolt Grades

A - Nominal Size
 C - SAE-5
 B - SAE-8
 D - SAE-2

Table 6.4 SAE Grade 8 Bolt and Grade 8 Free Spinning Nut

Nominal Size (A)	Torque (Nm)		Torque (lbf-ft) (*lbf-in)	
	Min.	Max.	Min.	Max.
1/4-20	16.8	18.6	*150	*165
5/16-18	35	38	26	28
3/8-16	61	68	46	50
7/16-14	98	109	73	81
1/2-13	150	166	111	123
9/16-12	217	239	160	177
5/8-11	299	330	221	345
3/4-10	531	587	393	435
7/8-9	855	945	633	700
1-8	1165	1288	863	954

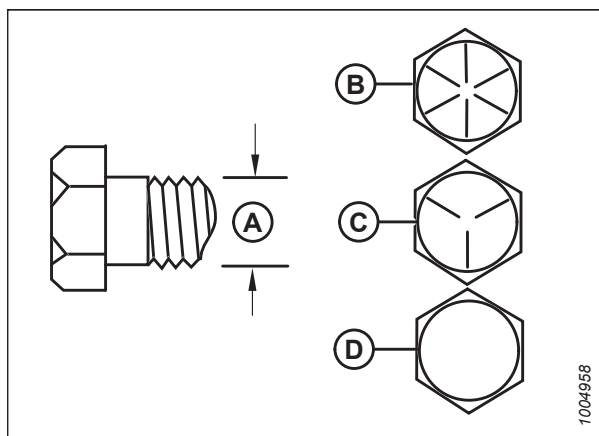

Figure 6.4: Bolt Grades

A - Nominal Size
 C - SAE-5
 B - SAE-8
 D - SAE-2

6.1.2 Metric Bolt Specifications

Specifications are provided for the appropriate final torque values to secure various sizes of metric bolts.

NOTE:

The torque values provided in the following metric bolt torque tables apply to hardware installed dry; that is, hardware with no grease, oil, or threadlocker on the threads or heads. Do **NOT** add grease, oil, or threadlocker to bolts or cap screws unless you are directed to do so in this manual.

Table 6.5 Metric Class 8.8 Bolts and Class 9 Free Spinning Nut

Nominal Size (A)	Torque (Nm)		Torque (lbf-ft) (*lbf-in)	
	Min.	Max.	Min.	Max.
3-0.5	1.4	1.6	*13	*14
3.5-0.6	2.2	2.5	*20	*22
4-0.7	3.3	3.7	*29	*32
5-0.8	6.7	7.4	*59	*66
6-1.0	11.4	12.6	*101	*112
8-1.25	28	30	20	23
10-1.5	55	60	40	45
12-1.75	95	105	70	78
14-2.0	152	168	113	124
16-2.0	236	261	175	193
20-2.5	460	509	341	377
24-3.0	796	879	589	651

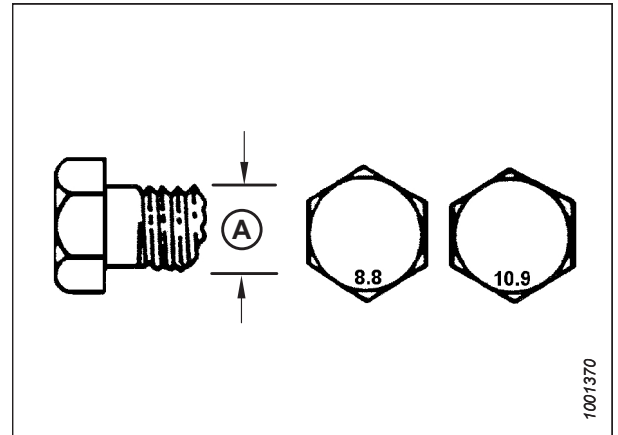

Figure 6.5: Bolt Grades

Table 6.6 Metric Class 8.8 Bolts and Class 9 Distorted Thread Nut

Nominal Size (A)	Torque (Nm)		Torque (lbf-ft) (*lbf-in)	
	Min.	Max.	Min.	Max.
3-0.5	1	1.1	*9	*10
3.5-0.6	1.5	1.7	*14	*15
4-0.7	2.3	2.5	*20	*22
5-0.8	4.5	5	*40	*45
6-1.0	7.7	8.6	*69	*76
8-1.25	18.8	20.8	*167	*185
10-1.5	37	41	28	30
12-1.75	65	72	48	53
14-2.0	104	115	77	85
16-2.0	161	178	119	132
20-2.5	314	347	233	257
24-3.0	543	600	402	444

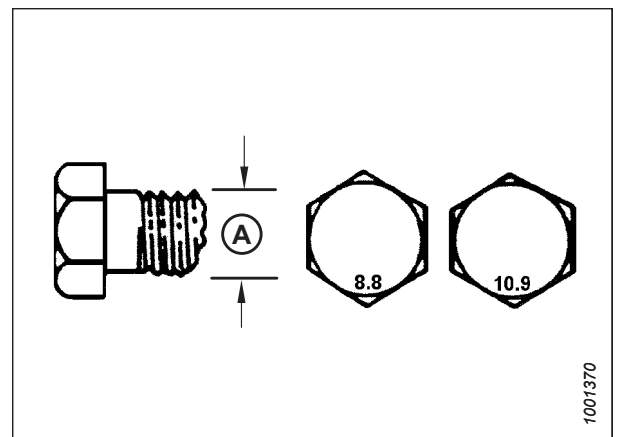

Figure 6.6: Bolt Grades

REFERENCE

Table 6.7 Metric Class 10.9 Bolts and Class 10 Free Spinning Nut

Nominal Size (A)	Torque (Nm)		Torque (lbf-ft) (*lbf-in)	
	Min.	Max.	Min.	Max.
3-0.5	1.8	2	*18	*19
3.5-0.6	2.8	3.1	*27	*30
4-0.7	4.2	4.6	*41	*45
5-0.8	8.4	9.3	*82	*91
6-1.0	14.3	15.8	*140	*154
8-1.25	38	42	28	31
10-1.5	75	83	56	62
12-1.75	132	145	97	108
14-2.0	210	232	156	172
16-2.0	326	360	242	267
20-2.5	637	704	472	521
24-3.0	1101	1217	815	901

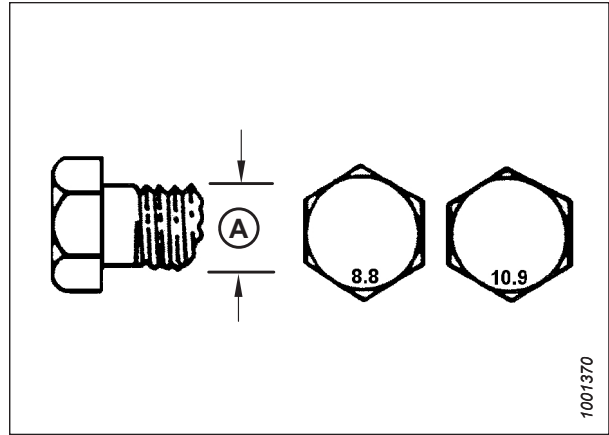

Figure 6.7: Bolt Grades

Table 6.8 Metric Class 10.9 Bolts and Class 10 Distorted Thread Nut

Nominal Size (A)	Torque (Nm)		Torque (lbf-ft) (*lbf-in)	
	Min.	Max.	Min.	Max.
3-0.5	1.3	1.5	*12	*13
3.5-0.6	2.1	2.3	*19	*21
4-0.7	3.1	3.4	*28	*31
5-0.8	6.3	7	*56	*62
6-1.0	10.7	11.8	*95	*105
8-1.25	26	29	19	21
10-1.5	51	57	38	42
12-1.75	90	99	66	73
14-2.0	143	158	106	117
16-2.0	222	246	165	182
20-2.5	434	480	322	356
24-3.0	750	829	556	614

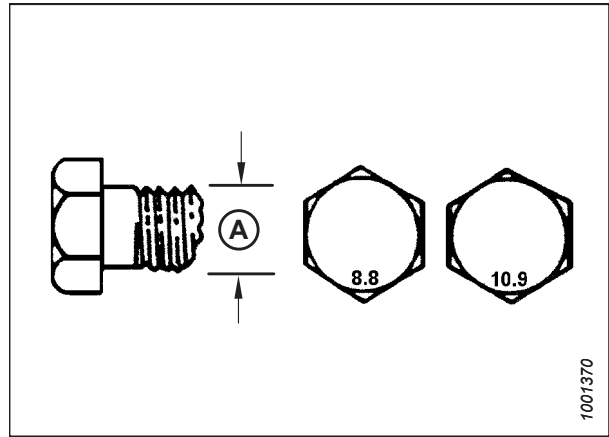

Figure 6.8: Bolt Grades

6.1.3 Metric Bolt Specifications – Cast Aluminum

Specifications are provided for the appropriate final torque values for various sizes of metric bolts in cast aluminum.

NOTE:

The torque values provided in the following metric bolt torque tables apply to hardware installed dry; that is, hardware with no grease, oil, or threadlocker on the threads or heads. Do **NOT** add grease, oil, or threadlocker to bolts or cap screws unless you are directed to do so in this manual.

REFERENCE

Table 6.9 Metric Bolt Bolting into Cast Aluminum

Nominal Size (A)	Bolt Torque			
	8.8 (Cast Aluminum)		10.9 (Cast Aluminum)	
	Nm	lbf-ft	Nm	lbf-ft
M3	–	–	–	1
M4	–	–	4	2.6
M5	–	–	8	5.5
M6	9	6	12	9
M8	20	14	28	20
M10	40	28	55	40
M12	70	52	100	73
M14	–	–	–	–
M16	–	–	–	–

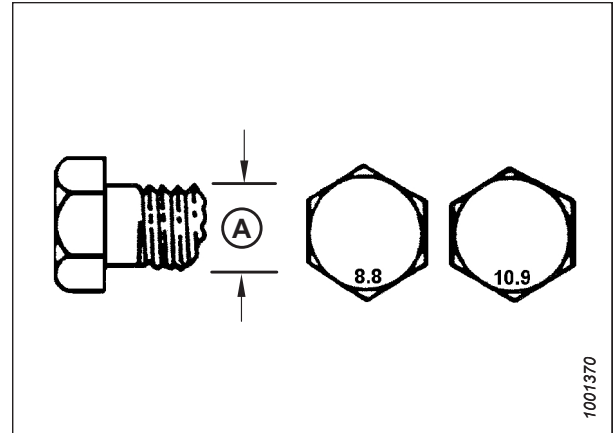

Figure 6.9: Bolt Grades

6.1.4 Flare-Type Hydraulic Fittings

The standard torque values are provided for flare-type hydraulic fittings. If a procedure specifies a different torque value for the same type and size of fitting found in this topic, refer to the value specified in the procedure instead.

1. Inspect flare (A) and flare seat (B) for defects that might cause leakage.
2. Align tube (C) with fitting (D) and thread nut (E) onto the fitting without lubrication until contact is made between the flared surfaces.
3. Torque fitting nut (E) to the specified number of flats from finger tight (FFFT) or to a given torque value in Table 6.10, page 61.
4. Secure fitting (D) with two wrenches. Place one wrench on fitting body (D), and tighten nut (E) with the other wrench to the torque value shown in Table 6.10, page 61.
5. Verify the final condition of connection.

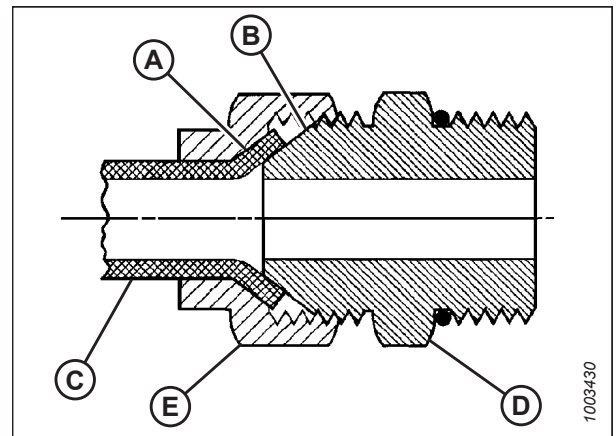

Figure 6.10: Hydraulic Fitting

Table 6.10 Flare-Type Hydraulic Tube Fittings

SAE Dash Size	Thread Size (in.)	Torque Value ⁵		Flats from Finger Tight (FFFT)	
		Nm	lbf-ft	Tube	Swivel Nut or Hose
-2	5/16–24	4–5	3–4	–	–
-3	3/8–24	7–8	5–6	–	–
-4	7/16–20	18–19	13–14	2 1/2	2
-5	1/2–20	19–21	14–15	2	2
-6	9/16–18	30–33	22–24	2	1 1/2
-8	3/4–16	57–63	42–46	2	1 1/2
-10	7/8–14	81–89	60–66	1 1/2	1 1/2

5. Torque values shown are based on lubricated connections as in reassembly.

REFERENCE

Table 6.10 Flare-Type Hydraulic Tube Fittings (continued)

SAE Dash Size	Thread Size (in.)	Torque Value ⁶		Flats from Finger Tight (FFFT)	
		Nm	lbf-ft	Tube	Swivel Nut or Hose
-12	1 1/16-12	113-124	83-91	1 1/2	1 1/4
-14	1 3/16-12	136-149	100-110	1 1/2	1 1/4
-16	1 5/16-12	160-176	118-130	1 1/2	1
-20	1 5/8-12	228-250	168-184	1	1
-24	1 7/8-12	264-291	195-215	1	1
-32	2 1/2-12	359-395	265-291	1	1
-40	3-12	—	—	1	1

6.1.5 O-Ring Boss Hydraulic Fittings – Adjustable

The standard torque values are provided for adjustable hydraulic fittings. If a procedure specifies a different torque value for the same type and size of fitting found in this topic, refer to the value specified in the procedure instead.

1. Inspect O-ring (A) and seat (B) for dirt or defects.
2. Back off lock nut (C) as far as possible. Ensure that washer (D) is loose and that it is pushed toward lock nut (C) as far as possible.
3. Ensure that O-ring (A) is **NOT** on the threads. Adjust O-ring (A) if necessary.
4. Apply hydraulic system oil to O-ring (A).

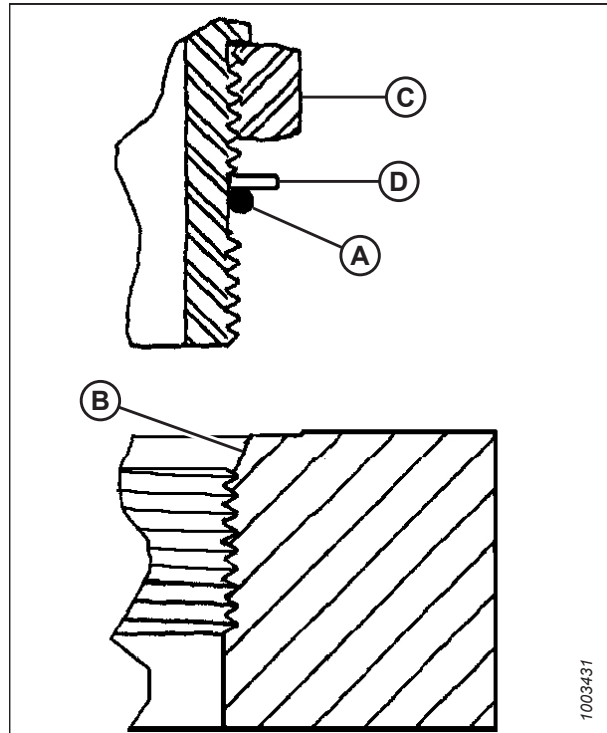

Figure 6.11: Hydraulic Fitting

6. Torque values shown are based on lubricated connections as in reassembly.

REFERENCE

5. Install fitting (B) into the port until backup washer (D) and O-ring (A) contact part face (E).
6. Position the angle fittings by unscrewing no more than one turn.
7. Turn lock nut (C) down to washer (D) and tighten it to the torque value indicated in the table. Use two wrenches, one on fitting (B) and the other on lock nut (C).
8. Verify the final condition of the fitting.

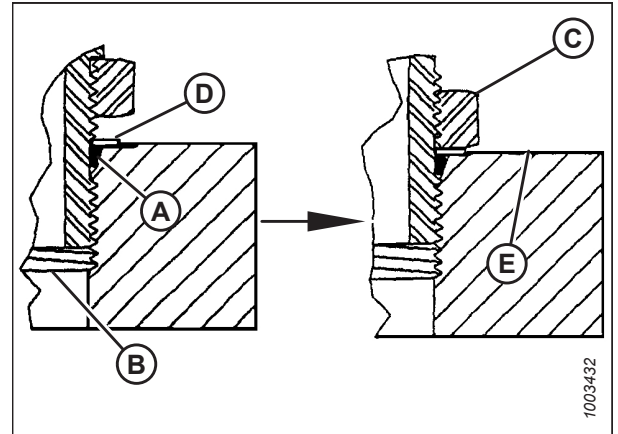

Figure 6.12: Hydraulic Fitting

Table 6.11 O-Ring Boss (ORB) Hydraulic Fittings – Adjustable and Non-Adjustable

SAE Dash Size	Thread Size (in.)	Torque Value ⁷	
		Nm	lbf·ft (*lbf·in)
-2	5/16-24	10-11	*89-97
-3	3/8-24	18-20	*159-177
-4	7/16-20	29-32	21-24
-5	1/2-20	32-35	24-26
-6	9/16-18	40-44	30-32
-8	3/4-16	70-77	52-57
-10	7/8-14	115-127	85-94
-12	1 1/16-12	183-201	135-148
-14	1 3/16-12	237-261	175-193
-16	1 5/16-12	271-298	200-220
-20	1 5/8-12	339-373	250-275
-24	1 7/8-12	414-455	305-336
-32	2 1/2-12	509-560	375-413

7. Torque values shown are based on lubricated connections as in reassembly.

6.1.6 O-Ring Boss Hydraulic Fittings – Non-Adjustable

The standard torque values for non-adjustable hydraulic fittings are provided. If a procedure specifies a different torque value for the same type and size of fitting found in this topic, use the value specified in the procedure instead.

1. Inspect O-ring (A) and seat (B) for dirt or defects.
2. Ensure that O-ring (A) is **NOT** on the threads. Adjust O-ring (A) if necessary.
3. Apply hydraulic system oil to the O-ring.
4. Install fitting (C) into the port until the fitting is hand-tight.
5. Torque fitting (C) according to values in Table 6.12, page 64.
6. Verify the final condition of the fitting.

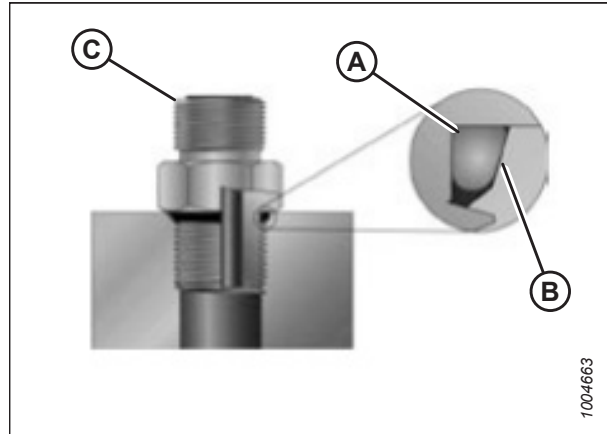

Figure 6.13: Hydraulic Fitting

Table 6.12 O-Ring Boss (ORB) Hydraulic Fittings – Adjustable and Non-Adjustable

SAE Dash Size	Thread Size (in.)	Torque Value ⁸	
		Nm	lbf·ft (*lbf·in)
-2	5/16-24	10-11	*89-97
-3	3/8-24	18-20	*159-177
-4	7/16-20	29-32	21-24
-5	1/2-20	32-35	24-26
-6	9/16-18	40-44	30-32
-8	3/4-16	70-77	52-57
-10	7/8-14	115-127	85-94
-12	1 1/16-12	183-201	135-148
-14	1 3/16-12	237-261	175-193
-16	1 5/16-12	271-298	200-220
-20	1 5/8-12	339-373	250-275
-24	1 7/8-12	414-455	305-336
-32	2 1/2-12	509-560	375-413

6.1.7 O-Ring Face Seal Hydraulic Fittings

The standard torque values are provided for O-ring face seal hydraulic fittings. If a procedure specifies a different torque value for the same type and size of fitting found in this topic, refer to the value specified in the procedure instead.

Torque values are shown in the Table 6.13, page 65.

8. Torque values shown are based on lubricated connections as in reassembly.

REFERENCE

1. Ensure that the sealing surfaces and the fitting threads are free of burrs, nicks, scratches, and any foreign material.



Figure 6.14: Hydraulic Fitting

2. Apply hydraulic system oil to O-ring (B).
3. Align the tube or hose assembly so that the flat face of sleeve (A) or (C) comes into full contact with O-ring (B).
4. Thread tube or hose nut (D) until it is hand-tight. The nut should turn freely until it bottoms out.
5. Torque the fittings according to values in Table 6.13, page 65.

NOTE:

If applicable, hold the hex flange on fitting body (E) to prevent the rotation of the fitting body and the hose when tightening fitting nut (D).

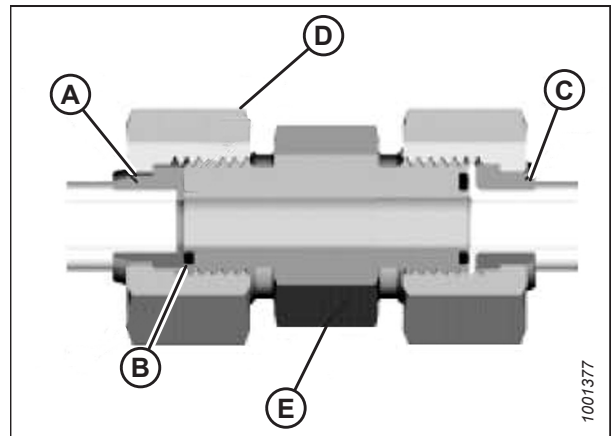

Figure 6.15: Hydraulic Fitting

6. Use three wrenches when assembling unions or joining two hoses together.
7. Verify the final condition of the fitting.

Table 6.13 O-Ring Face Seal (ORFS) Hydraulic Fittings

SAE Dash Size	Thread Size (in.)	Tube O.D. (in.)	Torque Value ⁹	
			Nm	lbf-ft
-3	Note ¹⁰	3/16	–	–
-4	9/16	1/4	25–28	18–21
-5	Note ¹⁰	5/16	–	–
-6	11/16	3/8	40–44	30–32
-8	13/16	1/2	55–61	41–45
-10	1	5/8	80–88	59–65
-12	1 3/16	3/4	115–127	85–94
-14	Note ¹⁰	7/8	–	–
-16	1 7/16	1	150–165	111–122

9. Torque values and angles shown are based on lubricated connection as in reassembly.

10. O-ring face seal type end not defined for this tube size.

REFERENCE

Table 6.13 O-Ring Face Seal (ORFS) Hydraulic Fittings (continued)

SAE Dash Size	Thread Size (in.)	Tube O.D. (in.)	Torque Value ¹¹	
			Nm	lbf-ft
-20	1 11/16	1 1/4	205–226	151–167
-24	2	1 1/2	315–347	232–256
-32	2 1/2	2	510–561	376–414

6.1.8 Tapered Pipe Thread Fittings

The standard torque values are provided for tapered pipe thread fittings. If a procedure specifies a different torque value for the same type and size of fitting found in this topic, refer to the value specified in the procedure instead.

Assemble pipe fittings as follows:

1. Ensure that the fitting and the port threads are free of burrs, nicks, scratches, and any other form of contamination.
2. Apply paste-type pipe thread sealant to the external pipe threads.
3. Thread the fitting into the port until it is hand-tight.
4. Torque the connector to the appropriate torque angle. The turns from finger tight (TFFT) and flats from finger tight (FFFT) values are shown in Table 6.14, page 66. Ensure that the tube end of a shaped connector (typically a 45° or 90° elbow) is aligned to receive the incoming tube or hose assembly. Always finish the alignment of the fitting in the direction of tightening. Never loosen the threaded connectors to achieve alignment.
5. Clean all residue and any excess thread conditioner with an appropriate cleaner.
6. Inspect the final condition of the fitting. Pay special attention to the possibility of cracks in the port opening.
7. Mark the final position of the fitting. If a fitting leaks, disassemble the fitting and check it for damage.

NOTE:

The failure of fittings due to over-torquing may not be evident until the fittings are disassembled and inspected.

Table 6.14 Hydraulic Fitting Pipe Thread

Tapered Pipe Thread Size	Recommended TFFT	Recommended FFFT
1/8–27	2–3	12–18
1/4–18	2–3	12–18
3/8–18	2–3	12–18
1/2–14	2–3	12–18
3/4–14	1.5–2.5	12–18
1–11 1/2	1.5–2.5	9–15
1 1/4–11 1/2	1.5–2.5	9–15
1 1/2–11 1/2	1.5–2.5	9–15
2–11 1/2	1.5–2.5	9–15

11. Torque values and angles shown are based on lubricated connection as in reassembly.

6.2 Conversion Chart

This manual uses both SI units (including metric) and US customary units (sometimes referred to as standard units) of measurement. A list of those units along with their abbreviations and conversion factors is provided here for your reference.

Table 6.15 Conversion Chart

Quantity	SI Units (Metric)		Factor	US Customary Units (Standard)	
	Unit Name	Abbreviation		Unit Name	Abbreviation
Area	hectare	ha	x 2.4710 =	acre	acres
Flow	liters per minute	L/min	x 0.2642 =	US gallons per minute	gpm
Force	Newton	N	x 0.2248 =	pound force	lbf
Length	millimeter	mm	x 0.0394 =	inch	in.
Length	meter	m	x 3.2808 =	foot	ft.
Power	kilowatt	kW	x 1.341 =	horsepower	hp
Pressure	kilopascal	kPa	x 0.145 =	pounds per square inch	psi
Pressure	megapascal	MPa	x 145.038 =	pounds per square inch	psi
Pressure	bar (Non-SI)	bar	x 14.5038 =	pounds per square inch	psi
Torque	Newton meter	Nm	x 0.7376 =	pound feet or foot pounds	lbf·ft
Torque	Newton meter	Nm	x 8.8507 =	pound inches or inch pounds	lbf·in
Temperature	degrees Celsius	°C	(°C x 1.8) + 32 =	degrees Fahrenheit	°F
Velocity	meters per minute	m/min	x 3.2808 =	feet per minute	ft/min
Velocity	meters per second	m/s	x 3.2808 =	feet per second	ft/s
Velocity	kilometers per hour	km/h	x 0.6214 =	miles per hour	mph
Volume	liter	L	x 0.2642 =	US gallon	US gal
Volume	milliliter	mL	x 0.0338 =	ounce	oz.
Volume	cubic centimeter	cm ³ or cc	x 0.061 =	cubic inch	in. ³
Weight	kilogram	kg	x 2.2046 =	pound	lb.

Index

10948.....	53	136748.....	53
13125.....	49	139974.....	53
16652.....	47	152439.....	47
18601.....	51	152668.....	47, 51, 53
18648.....	49	152732.....	51
21763.....	49, 53	166466.....	55
30505.....	49	174683.....	55
30628.....	49	184372.....	55
30753.....	49	184595.....	51
30994.....	53	184640.....	53
32247.....	47	184692.....	47
42046.....	49	184694.....	51
50019.....	53	184701.....	51, 53
50193.....	49	184711.....	47
109575.....	53	184714.....	51
111978.....	49	191393.....	47
112940.....	49	197230.....	51, 53
128681.....	53	200974.....	53
128697.....	47	203350.....	47
128729.....	47	209256.....	49
128737.....	47, 49	232597.....	49
128740.....	47	247693.....	47
128756.....	49	252291.....	51
128762.....	49	252872.....	47
128764.....	49	277041.....	49
128768.....	49	277042.....	49
128770.....	49	277043.....	53
128773.....	49	277323.....	47
128776.....	49	277331.....	49
128780.....	49	277405.....	47
128781.....	49	277409.....	47
128788.....	49	277414.....	47
128789.....	49	277435.....	49
128972.....	53	291638.....	49, 55
128973.....	49, 55	302204.....	55
128994.....	49	306261.....	53
135312.....	49	306660.....	47
135337.....	47	306661.....	47
135386.....	49	306662.....	47
135474.....	49	310620.....	49
135691.....	51		
135778.....	49		
135799.....	51		
135917.....	53		
136095.....	49, 53		
136144.....	49		
136149.....	49		
136151.....	49		
136178.....	51		
136194.....	49		
136604.....	51		
136655.....	49		
136731.....	51		

A

adjustments	
compression.....	38
side deflectors.....	38
auxiliary lift manifold	
installing.....	24

B

bar clamps.....	16
-----------------	----

INDEX

C

cab display module	
programming	33
controls and automated functions	35
compression.....	38
lock and unlock.....	39
conversion chart	67

D

decals	
parts list	54
safety signs	10

F

frames	
installing.....	16

H

harnesses	
installing.....	19–20, 23
hydraulics	
connecting hydraulics	25
fittings	
flare-type	61
O-ring boss – adjustable.....	62
O-ring boss – non-adjustable	64
O-ring face seal	64
tapered pipe thread fittings.....	66
hydraulic safety	7

I

installation	13, 16
initial settings.....	36
installing shield.....	28
removing from shipping crate.....	13

L

lock and unlock swath compressor	39
--	----

M

maintenance and servicing.....	41
safety.....	5
shield	
installing shield.....	28
shield assembly	
removing shield assembly	41

spare parts.....	43
metric bolts	
torque specifications	59

O

operation.....	33
initial settings.....	36

P

parts lists	43
completion package supplemental parts	52
decals	54
hydraulics and supports	48
shield assembly	46
predelivery checklist	73

R

recommended fluids and lubricants.....	75
reverse switches	
installing.....	19
model year 2017 and prior	20
model year 2018 and later.....	23
rocker switches	
installing.....	27

S

SAE	
bolt torques	57
safety.....	1
general safety.....	3
hydraulic safety	7
maintenance safety	5
safety alert symbols.....	1
safety sign decals	9–10
installing decals	9
parts list.....	54
signal words.....	2
welding precautions	8
sensor arms.....	16
setup.....	13
<i>See also</i> installation	
initial settings.....	36
shields	
installing shield.....	28
removing shield assembly.....	41
side deflectors	38
spare parts	
decals	54
hydraulics and supports	48

INDEX

specifications	
torque specifications	57

T

torque specifications	57
flare-type hydraulic fittings	61
metric bolt specifications.....	59
cast aluminum.....	60
O-ring boss hydraulic fittings – adjustable.....	62
O-ring boss hydraulic fittings – non-adjustable	64
O-ring face seal fittings	64
SAE bolt torque specifications	57
tapered pipe thread fittings	66

V

valve blocks, *See* auxiliary lift manifold

W

welding.....	8
--------------	---

Predelivery Checklist

Perform these checks and adjustments prior to delivery to your Customer. The completed checklist should be retained by either the Operator or the Dealer.

 **CAUTION**

Follow the instructions carefully. Pay attention to safety-related messages, and avoid unsafe practices.

✓	Item	Reference
	Check for shipping damage or missing parts. Be sure all shipping dunnage is removed.	—
	Check for loose hardware. Tighten to required torque.	6.1 Torque Specifications, page 57
	Raise and lower swath compressor to check for linkage binding. Rubber bumpers at rear should contact windrower frame when fully raised. If binding occurs, adjust by adding/removing washers (MD #30635) where rear supports are fastened to the outside of frame.	2.2.1 Installing Frame, page 16
	Ensure sensor arm does not bind when raising or lowering the swath compressor.	2.2.1 Installing Frame, page 16
	Check hydraulic hose and electrical harness routing for clearance when raising or lowering swath compressor. Adjust as necessary.	2.2.4 Connecting Hydraulics, page 25 2.2.2 Installing Reverse Switch and Harness, page 19
	Ensure hydraulic hoses are secured in place with cable ties.	2.2.4 Connecting Hydraulics, page 25
	Ensure swath compressor lock is functioning properly.	3.2.4 Locking and Unlocking Swath Compressor, page 39
	Check for hydraulic leaks.	—
	Ensure side deflectors are set evenly to desired position.	3.2.3 Adjusting Side Deflectors, page 38
	Ensure latest software version is installed in windrower.	Refer to windrower operator's manual.

Date checked: _____ Checked by: _____

Recommended Fluids and Lubricants

Ensure your machine operates at top efficiency by using clean fluids and lubricants only.

- Use clean containers to handle all fluids and lubricants.
- Store fluids and lubricants in an area protected from dust, moisture, and other contaminants.

Lubricant	Specification	Description	Use	Capacities
Grease	SAE multi-purpose	High temperature extreme pressure (EP) performance with 1% max. molybdenum disulphide (NLGI Grade 2) lithium base	As required unless otherwise specified	—

MacDon®

CUSTOMERS
MacDon.com

DEALERS
Portal.MacDon.com

Trademarks of products are the marks of their
respective manufacturers and/or distributors.

Printed in Canada