

HC10 Hay Conditioner for D-Series Draper Headers

Setup, Operation, and Parts Manual

169254 Revision E

Original Instruction

MacDon HC10 Hay Conditioner

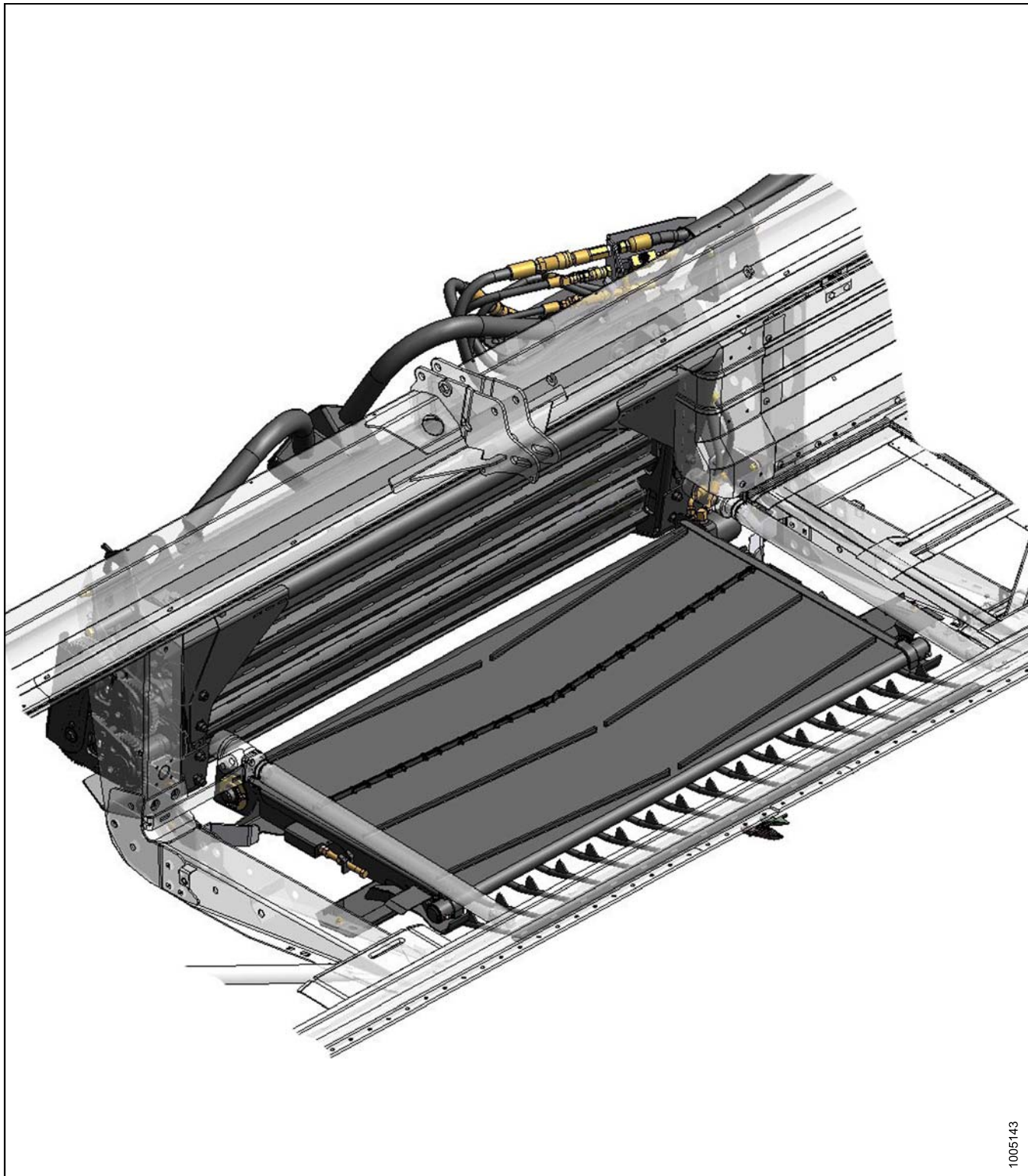

1005143

Introduction

This manual contains safety information, setup instructions, operating and maintenance procedures, and parts information for the MacDon HC10 Hay Conditioner. Conditioning or crimping cut hay allows moisture release for quicker drying and earlier processing. This hay conditioner, when teamed with an M-Series Self-Propelled Windrower power unit and a D-Series Draper Header, will condition crop cut by the header, which the windrower lays into uniform, fluffy windrows. **The HC10 Hay Conditioner is NOT intended for use with the M105 or M205 Self-Propelled Windrower power unit.**

CAREFULLY READ ALL THE MATERIAL PROVIDED BEFORE ATTEMPTING TO UNLOAD, ASSEMBLE, OR USE THE MACHINE.

Use this manual as your first source of information about the machine. If you follow the instructions given in this manual, your hay conditioner will work well for many years. Use this manual in conjunction with your M-Series Self-Propelled Windrower and D-Series Draper Header manuals.

Use the Table of Contents and Index to guide you to specific topics. Review the Table of Contents to familiarize yourself with how the material is organized.

Keep this manual handy for frequent reference and to pass on to new Operators or Owners. Call your Dealer if you need assistance, information, or additional copies of this manual.

NOTE:

Keep your MacDon publications up-to-date. The most current version can be downloaded from our website (www.macdon.com) or from our Dealer-only site (<https://portal.macdon.com>)(login required).

A Russian translation of this manual (MD #169347) can be ordered from MacDon, downloaded from the Dealer Portal (<https://portal.macdon.com>)(login required), or downloaded from the MacDon International Website (<http://www.macdon.com/world>).

List of Revisions

The following list provides an account of major changes from the previous version of this document.

Summary of Change	Location
Note regarding access to updated manuals added to Introduction.	Introduction, page i
Paragraph regarding access to Russian translation of this manual added to Introduction.	Introduction, page i
Note regarding incompatibility with M105 and M205 Self-Propelled Windrowers added.	Introduction, page i and 2.3 Specifications, page 23
List of Revisions added.	List of Revisions, page ii
Removed unnecessary sections from Safety that do not apply to the Hay Conditioner.	1 Safety, page 1
Definitions added.	2 General Information, page 9
Revised instructions in Unloading the Hay Conditioner to clarify step 2.	3.1 Unloading the Hay Conditioner, page 29
Header schematics added.	3.8 Header Schematics, page 50 and 5.5.2 Hydraulic Schematics, page 94
Updated image in step 2 of Installing the Forming Shield to show previously missing forming shield.	3.10 Installing the Forming Shield, page 55
Corrected manual part number from MD #169524 to MD #169254 in Storing Manuals.	3.13.5 Storing Manuals, page 64
Revised procedure in Shutting Down the Machine.	4.2.1 Shutting Down the Machine, page 66
Changed title from Storage to Storing the Hay Conditioner.	4.10 Storing the Hay Conditioner, page 88
Changed title from Drive Shields to Removing and Installing Driveshields.	5.3 Removing and Installing Driveshields, page 91
Changed title from Lubrication Points to Greasing Points to make section title consistent with content.	5.4.3 Greasing Points, page 93
Added illustration in Adjusting Feed Draper Tension to show draper guide and revised step 2 to clarify that idler roller should be inboard of draper guide.	5.6.1 Adjusting Feed Draper Tension, page 95
Corrected units of force to lbf and N.	5.7.1 Adjusting Drive Belt Tension, page 96
Reformatted Troubleshooting to make it more consistent with current Operator's manuals.	5.9 Troubleshooting, page 104
General text and formatting revisions to improve readability.	Various locations throughout
Figure titles added and revised.	Various locations throughout

Serial Numbers

Record the serial number of the hay conditioner in the space below.

HAY CONDITIONER SERIAL NO: _____

Serial Number Plate (A) is located on the rear cover of the conditioner frame as shown below.

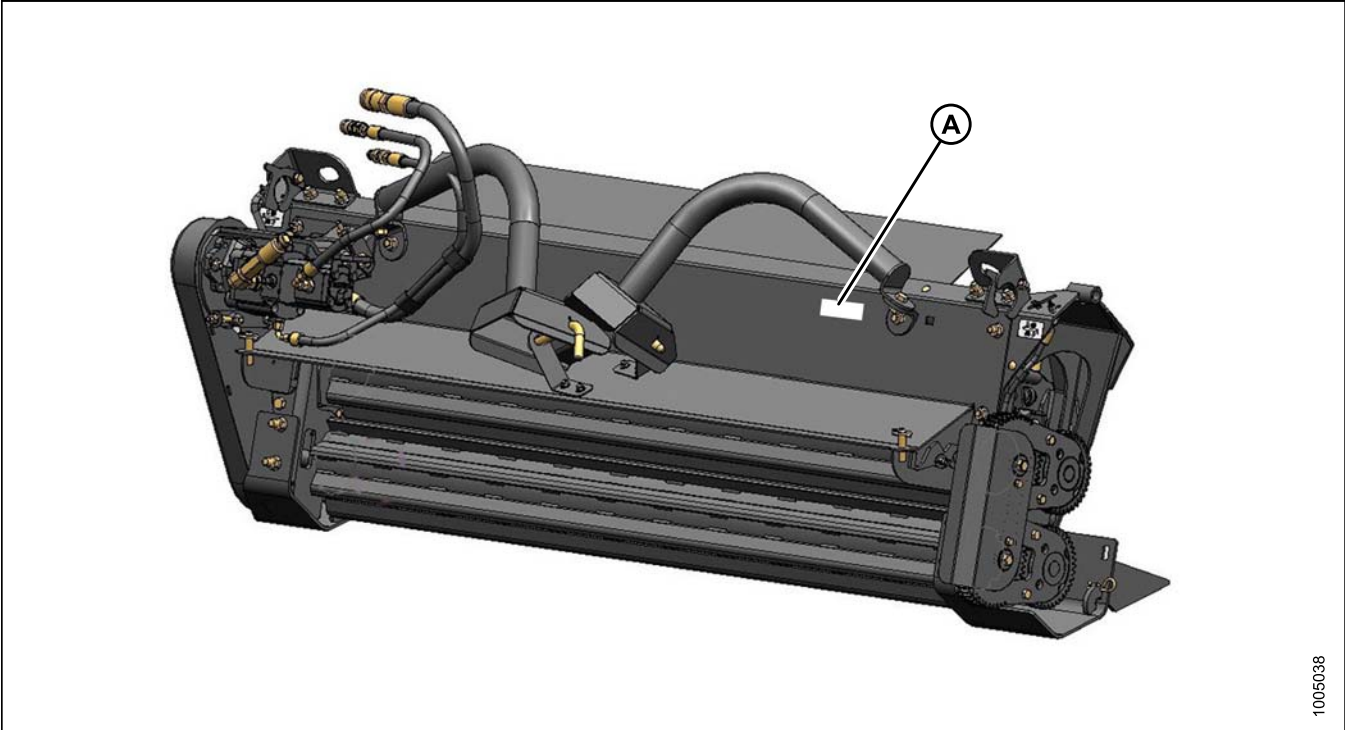

1005038

Figure 1: Serial Number Plate

TABLE OF CONTENTS

Introduction	i
List of Revisions	ii
Serial Numbers	iii
1 Safety	1
1.1 Safety Alert Symbols	1
1.2 Signal Words	2
1.3 General Safety	3
1.4 Maintenance Safety	5
1.5 Hydraulic Safety	6
1.6 Safety Signs	7
1.6.1 Installing Safety Decals	7
2 General Information	9
2.1 Definitions	9
2.2 Torque Specifications	11
2.2.1 SAE Bolt Torque Specifications	11
2.2.2 Metric Bolt Specifications	13
2.2.3 Metric Bolt Specifications Bolting into Cast Aluminum	16
2.2.4 Flare-Type Hydraulic Fittings	16
2.2.5 O-Ring Boss (ORB) Hydraulic Fittings (Adjustable)	18
2.2.6 O-Ring Boss (ORB) Hydraulic Fittings (Non-Adjustable)	20
2.2.7 O-Ring Face Seal (ORFS) Hydraulic Fittings	21
2.3 Specifications	23
2.4 Conversion Chart	24
2.5 Component Identification	25
3 Unloading and Assembly	29
3.1 Unloading the Hay Conditioner	29
3.2 Preparing the Header	31
3.3 Installing the Rock Grate	32
3.4 Installing Deck Brackets	33
3.5 Installing the Feed Deck	35
3.6 Installing the Conditioner	37
3.6.1 Installing Conditioner: Lifting Method	37
3.6.2 Installing Conditioner: Windrower Method	39
3.7 Attaching Hydraulics	45
3.7.1 Attaching Hydraulics: 15-Foot Headers	45
3.7.2 Attaching Hydraulics: All Headers Except 15-Foot	47
3.8 Header Schematics	50
3.9 Assembling the Forming Shield	52
3.10 Installing the Forming Shield	55
3.11 Attaching to a Windrower	57
3.12 Lubricating the Conditioner	58
3.12.1 Greasing Procedure	58
3.12.2 Lubrication Points	59
3.13 Performing Predelivery Checks	61
3.13.1 Checking Roll Drive Belt Tension	61
3.13.2 Checking Roll Gap	62
3.13.3 Checking Roll Timing	62
3.13.4 Running Up the Conditioner	63
3.13.5 Storing Manuals	64
4 Operation	65
4.1 Owner/Operator Responsibilities	65
4.2 Operational Safety	66
4.2.1 Shutting Down the Machine	66

TABLE OF CONTENTS

4.3	Attaching Hay Conditioner to Header	67
4.4	Detaching Hay Conditioner from Header	68
4.4.1	Detaching Hay Conditioner: Windrower Method	68
4.4.2	Detaching Hay Conditioner: Lifting Method	72
4.5	Detaching Feed Deck and Rock Grate	76
4.6	Break-in Period.....	79
4.7	Preseason Check	80
4.8	Daily Startup Check	81
4.9	Conditioner Operation	82
4.9.1	Roll and Feed Draper Speed.....	82
4.9.2	Adjusting Roll Gap	82
4.9.3	Checking and Adjusting Roll Timing.....	83
4.9.4	Adjusting Conditioner Roll Tension	84
4.9.5	Forming Shields	85
	Adjusting Forming Shield Height	86
	Adjusting Side Deflectors	86
	Adjusting Rear Deflector (Fluffer Shield).....	87
	Adjusting Deflector Fins	87
4.9.6	Unplugging the Conditioner.....	87
4.10	Storing the Hay Conditioner.....	88
5	Maintenance.....	89
5.1	Preparation for Servicing.....	89
5.2	Recommended Safety Procedures.....	90
5.3	Removing and Installing Driveshields	91
5.4	Lubrication	92
5.4.1	Lubricants.....	92
5.4.2	Greasing Procedure	92
5.4.3	Greasing Points	93
5.5	Hydraulics	94
5.5.1	Hydraulic Hoses and Lines	94
5.5.2	Hydraulic Schematics	94
5.6	Feed Draper.....	95
5.6.1	Adjusting Feed Draper Tension	95
5.7	Drive Belt	96
5.7.1	Adjusting Drive Belt Tension.....	96
5.7.2	Adjusting Drive Belt Pulley Alignment	97
5.7.3	Checking and Adjusting Drive Belt Tracking	98
5.7.4	Removing Drive Belt.....	100
5.7.5	Installing Drive Belt.....	100
5.8	Maintenance Schedule.....	102
5.9	Troubleshooting.....	104
6	Repair Parts	107
6.1	Abbreviations	107
6.1.1	Serial Number Breaks	107
6.2	Lower Roll and Frame Assembly	108
6.3	Upper Roll Assembly	110
6.4	Cover and Supports.....	112
6.5	Hydraulic Motor, Mounts, and Tensioner	116
6.6	Belt Drive and Shield	120
6.7	Hydraulic Completion Package	122
6.8	Gears and Roll Coupling Assembly	126
6.9	Forming Shields	128
6.10	Feed Deck and Pan	130

TABLE OF CONTENTS

6.11	Mounting Brackets	134
Index	137
	Model HC10 Hay Conditioner Predelivery Checklist	141

1 Safety

1.1 Safety Alert Symbols

This safety alert symbol indicates important safety messages in this manual and on safety signs on the hay conditioner.

This symbol means:

- **ATTENTION!**
- **BECOME ALERT!**
- **YOUR SAFETY IS INVOLVED!**

Carefully read and follow the safety message accompanying this symbol.

Why is safety important to you?

- Accidents disable and kill
- Accidents cost
- Accidents can be avoided



Figure 1.1: Safety Symbol

1.2 Signal Words

Three signal words, “DANGER”, “WARNING”, and “CAUTION”, are used to alert you to hazardous situations. The appropriate signal word for each situation has been selected using the following guidelines:

DANGER

Indicates an imminently hazardous situation that, if not avoided, will result in death or serious injury.

WARNING

Indicates a potentially hazardous situation that, if not avoided, could result in death or serious injury. It may also be used to alert against unsafe practices.

CAUTION

Indicates a potentially hazardous situation that, if not avoided, may result in minor or moderate injury. It may be used to alert against unsafe practices.

1.3 General Safety

CAUTION

The following are general farm safety precautions that should be part of your operating procedure for all types of machinery.

Protect yourself.

- When assembling, operating, and servicing machinery, wear all the protective clothing and personal safety devices that **COULD** be necessary for the job at hand. Don't take chances. You may need:
 - A hard hat
 - Protective footwear with slip resistant soles
 - Protective glasses or goggles
 - Heavy gloves
 - Wet weather gear
 - A respirator or filter mask
- Be aware that exposure to loud noise can cause impairment or loss of hearing. Wear suitable hearing protection devices such as ear muffs or ear plugs to help protect against objectionable or loud noises.

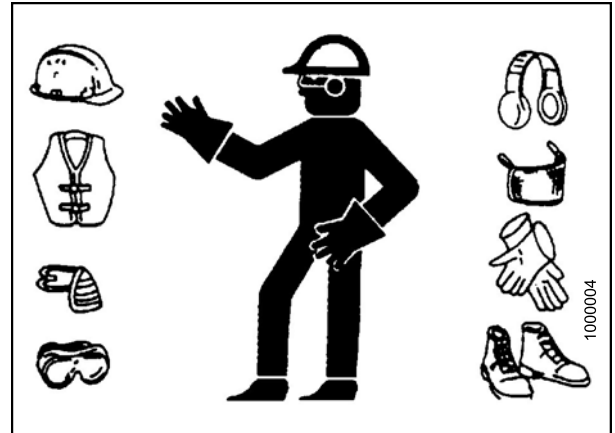

Figure 1.2: Safety Equipment



Figure 1.3: Safety Equipment

- Provide a first aid kit for use in case of emergencies.
- Keep a fire extinguisher on the machine. Be sure the fire extinguisher is properly maintained. Be familiar with its proper use.
- Keep young children away from the machinery at all times.
- Be aware that accidents often happen when the Operator is tired or in a hurry to get finished. Take the time to consider the safest way. Never ignore warning signs of fatigue.

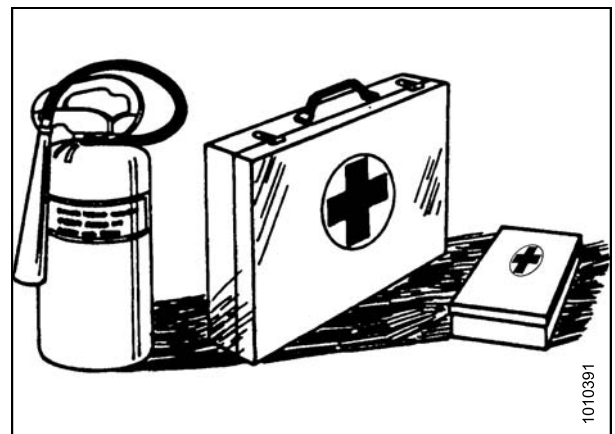

Figure 1.4: Safety Equipment

SAFETY

- Wear close-fitting clothing and cover long hair. Never wear dangling items such as scarves or bracelets.
- Keep all shields in place. Never alter or remove safety equipment. Make sure driveline guards can rotate independently of the shaft and can telescope freely.
- Use only service and repair parts made or approved by the equipment manufacturer. Substituted parts may not meet strength, design, or safety requirements.



Figure 1.5: Safety Around Equipment

- Keep hands, feet, clothing, and hair away from moving parts. Never attempt to clear obstructions or objects from a machine while the engine is running.
- Do **NOT** modify the machine. Non-authorized modifications may impair machine function and/or safety. It may also shorten the machine's life.
- Stop the engine and remove the key from ignition before leaving operator's seat for any reason. A child or even a pet could engage an idling machine.

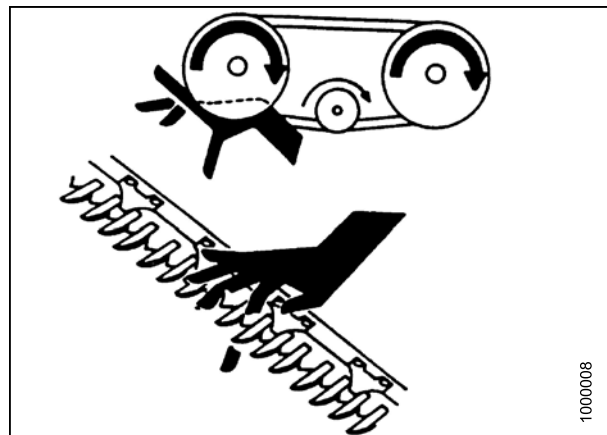

Figure 1.6: Safety Around Equipment

- Keep the service area clean and dry. Wet or oily floors are slippery. Wet spots can be dangerous when working with electrical equipment. Be sure all electrical outlets and tools are properly grounded.
- Keep work area well lit.
- Keep machinery clean. Straw and chaff, on a hot engine, are a fire hazard. Do **NOT** allow oil or grease to accumulate on service platforms, ladders, or controls. Clean machines before storage.
- Never use gasoline, naphtha, or any volatile material for cleaning purposes. These materials may be toxic and/or flammable.
- When storing machinery, cover sharp or extending components to prevent injury from accidental contact.



Figure 1.7: Safety Around Equipment

1.4 Maintenance Safety

To ensure your safety while maintaining the machine:

- Review the operator's manual and all safety items before operation and/or maintenance of the machine.
- Place all controls in Neutral, stop the engine, set the park brake, remove the ignition key, and wait for all moving parts to stop before servicing, adjusting, and/or repairing.
- Follow good shop practices:
 - Keep service areas clean and dry
 - Be sure electrical outlets and tools are properly grounded
 - Use adequate lighting for the job at hand
- Relieve pressure from hydraulic circuits before servicing and/or disconnecting the machine.
- Make sure all components are tight and that steel lines, hoses, and couplings are in good condition before applying pressure to a hydraulic system..
- Keep hands, feet, clothing, and hair away from all moving and/or rotating parts.
- Clear the area of bystanders, especially children, when carrying out any maintenance and repairs or when making any adjustments.
- Install transport lock or place safety stands under the frame before working under the hay conditioner.
- If more than one person is servicing the machine at the same time, be aware that rotating a driveline or other mechanically driven component by hand (for example, accessing a lube fitting) will cause drive components in other areas (belts, pulleys, and knife) to move. Stay clear of driven components at all times.
- Wear protective gear when working on the machine.
- Wear heavy gloves when working on knife components.



Figure 1.8: Safety Around Equipment

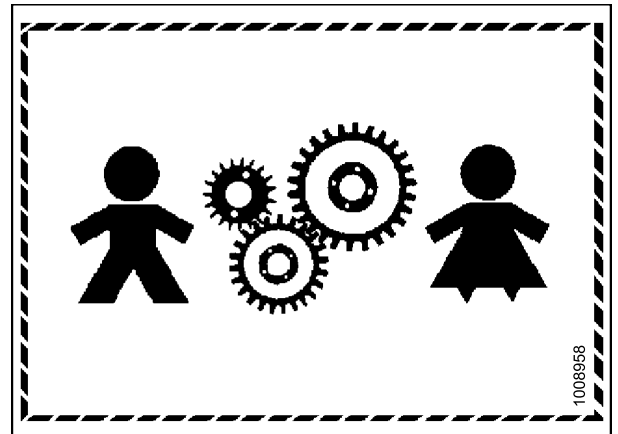

Figure 1.9: Equipment NOT Safe for Children

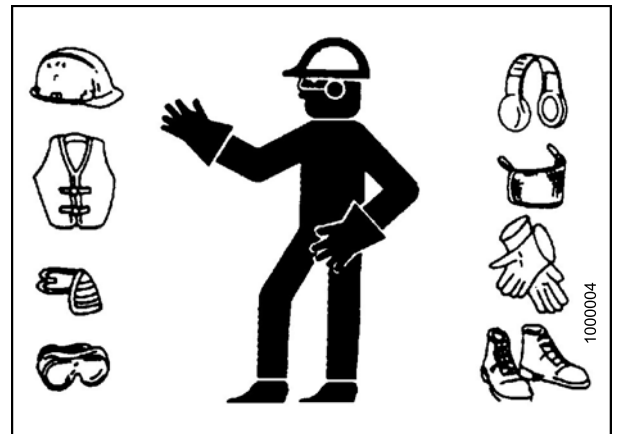

Figure 1.10: Safety Equipment

1.5 Hydraulic Safety

- Always place all hydraulic controls in Neutral before dismounting.
- Make sure that all components in the hydraulic system are kept clean and in good condition.
- Replace any worn, cut, abraded, flattened, or crimped hoses and steel lines.
- Do **NOT** attempt any makeshift repairs to the hydraulic lines, fittings, or hoses by using tapes, clamps, cements, or welding. The hydraulic system operates under extremely high pressure. Makeshift repairs will fail suddenly and create a hazardous and unsafe condition.

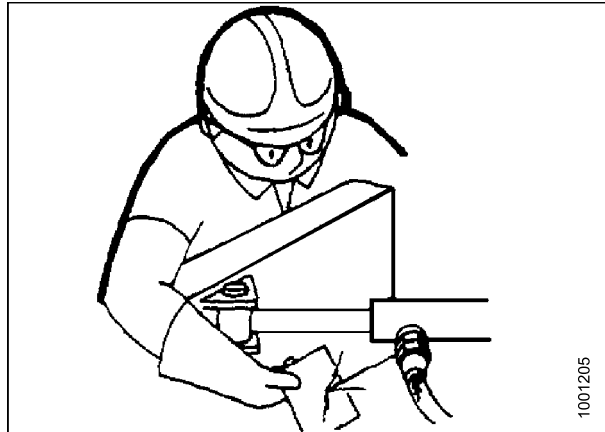

Figure 1.11: Testing for Hydraulic Leaks

- Wear proper hand and eye protection when searching for a high-pressure hydraulic leak. Use a piece of cardboard as a backstop instead of hands to isolate and identify a leak.
- If injured by a concentrated high-pressure stream of hydraulic fluid, seek medical attention immediately. Serious infection or toxic reaction can develop from hydraulic fluid piercing the skin.



Figure 1.12: Hydraulic Pressure Hazard

- Make sure all components are tight and that steel lines, hoses, and couplings are in good condition before applying pressure to a hydraulic system.

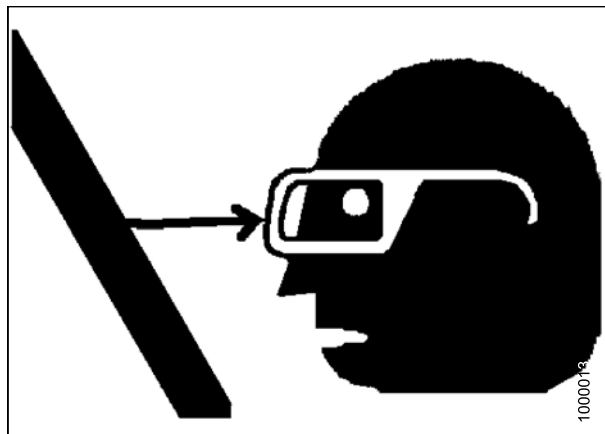

Figure 1.13: Safety Around Equipment

1.6 Safety Signs

- Keep safety signs clean and legible at all times.
- Replace safety signs that are missing or become illegible.
- If original parts on which a safety sign was installed are replaced, be sure the repair part also bears the current safety sign.
- Safety signs are available from your Dealer Parts Department.

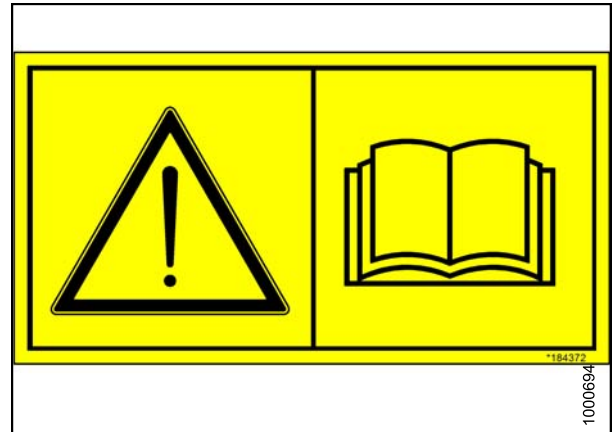

Figure 1.14: Operator's Manual Decal

1.6.1 Installing Safety Decals

To install a safety decal, follow these steps:

1. Clean and dry the installation area.
2. Decide on the exact location before you remove the decal backing paper.
3. Remove the smaller portion of the split backing paper.
4. Place the sign in position and slowly peel back the remaining paper, smoothing the sign as it is applied.
5. Prick small air pockets with a pin and smooth out.

2 General Information

2.1 Definitions

The following terms and acronyms may be used in this manual.

Term	Definition
API	American Petroleum Institute
ASTM	American Society of Testing and Materials
Bolt	A headed and externally threaded fastener that is designed to be paired with a nut
Center-link	A hydraulic cylinder link between the header and the machine to which it is attached: It is used to change header angle
CGVW	Combined vehicle gross weight
D-Series header	MacDon rigid draper header
DK	Double knife
DKD	Double-knife drive
Finger tight	Finger tight is a reference position where sealing surfaces or components are making contact with each other and the fitting has been tightened to a point where the fitting is no longer loose
FFFT	Flats from finger tight
GSL	Ground speed lever
GVW	Gross vehicle weight
Hard joint	A joint made with the use of a fastener where the joining materials are highly incompressible
Header	A machine that cuts and lays crop into a windrow and is attached to a self-propelled windrower
Hex key	A hex key or Allen key (also known by various other synonyms) is a tool of hexagonal cross-section used to drive bolts and screws that have a hexagonal socket in the head (internal-wrenching hexagon drive)
HDS	Hydraulic deck shift
hp	Horsepower
ISC	Intermediate Speed Control
JIC	Joint Industrial Council: a standards body that developed the standard sizing and shape for original 37° flared fitting
n/a	Not applicable
Nut	An internally threaded fastener that is designed to be paired with a bolt
N-DETENT	The slot opposite the NEUTRAL position on operator's console
NPT	National Pipe Thread: a style of fitting used for low pressure port openings. Threads on NPT fittings are uniquely tapered for an interference fit
ORB	O-ring boss: a style of fitting commonly used in port opening on manifolds, pumps and motors

GENERAL INFORMATION

Term	Definition
ORFS	O-ring face seal: a style of fitting commonly used for connecting hoses and tubes. This style of fitting is also commonly called ORS, which stands for O-ring seal
PTO	Power Take-Off
RoHS (Reduction of Hazardous Substances)	A directive by the European Union to restrict the use of certain hazardous substances (such as hexavalent chromium used in some yellow zinc platings)
SAE	Society of Automotive Engineers
Screw	A headed and externally threaded fastener that threads into preformed threads or forms its own thread in one of the mating parts
Self-Propelled (SP) Windrower	Self-propelled machine consisting of a power unit with a header
Soft joint	A joint made with the use of a fastener where the joining materials are compressible or experience relaxation over a period of time
spm	Strokes per minute
Tractor	Agricultural type tractor
Truck	A four-wheel highway/road vehicle weighing no less than 7500 lbs (3400 kg)
Timed knife drive	Synchronized motion applied at the cutterbar to two separately driven knives from a single hydraulic motor
Tension	Axial load placed on a bolt or screw, usually measured in pounds (lb) or Newtons (N)
TFFT	Turns from finger tight
Torque	The product of a force X lever arm length, usually measured in foot-pounds (ft-lbf) or Newton-meters (N·m)
Torque angle	A tightening procedure where the fitting is assembled to a precondition (finger tight) and then the nut is turned further a number of degrees or a number of flats to achieve its final position
Torque-tension	The relationship between the assembly torque applied to a piece of hardware and the axial load it induces in the bolt or screw
UCA	Upper cross auger
Washer	A thin cylinder with a hole or slot located in the center and is to be used as a spacer, load distribution element, or a locking mechanism
Windrower	Power unit of a self-propelled header

GENERAL INFORMATION

2.2 Torque Specifications

The following tables provide the correct torque values for various bolts, cap screws, and hydraulic fittings.

- Tighten all bolts to the torque values specified in the charts (unless otherwise noted throughout this manual).
- Replace hardware with the same strength and grade of bolt.
- Use the torque value tables as a guide and periodically check tightness of bolts.
- Understand torque categories for bolts and cap screws by using their identifying head markings.

2.2.1 SAE Bolt Torque Specifications

Torque values shown in the following tables are valid for non-greased, or non-oiled threads and heads; therefore, do **NOT** grease or oil bolts or cap screws unless otherwise specified in this manual.

Table 2.1 SAE Grade 5 Bolt and Grade 5 Free Spinning Nut

Nominal Size (A)	Torque (ft·lbf) (*in·lbf)		Torque (N·m)	
	Min.	Max.	Min.	Max.
1/4-20	*106	*117	11.9	13.2
5/16-18	*218	*241	24.6	27.1
3/8-16	32	36	44	48
7/16-14	52	57	70	77
1/2-13	79	87	106	118
9/16-12	114	126	153	170
5/8-11	157	173	212	234
3/4-10	281	311	380	420
7/8-9	449	496	606	669
1-8	611	676	825	912

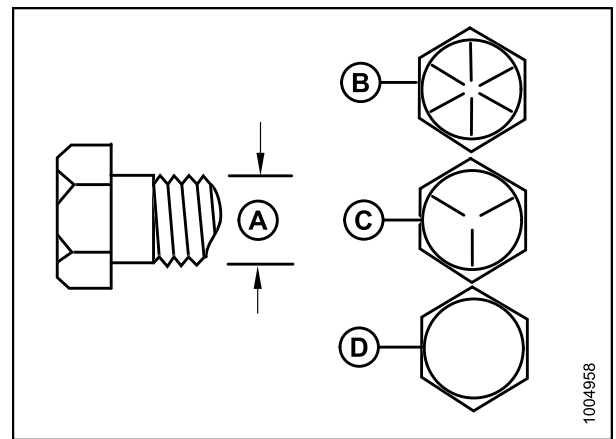

Figure 2.1: Bolt Grades

A - Nominal Size
C - SAE-5

B - SAE-8
D - SAE-2

GENERAL INFORMATION

Table 2.2 SAE Grade 5 Bolt and Grade F Distorted Thread Nut

Nominal Size (A)	Torque (ft-lbf) (*in-lbf)		Torque (N-m)	
	Min.	Max.	Min.	Max.
1/4-20	*72	*80	8.1	9
5/16-18	*149	*164	16.7	18.5
3/8-16	22	24	30	33
7/16-14	35	39	48	53
1/2-13	54	59	73	80
9/16-12	77	86	105	116
5/8-11	107	118	144	160
3/4-10	192	212	259	286
7/8-9	306	338	413	456
1-8	459	507	619	684

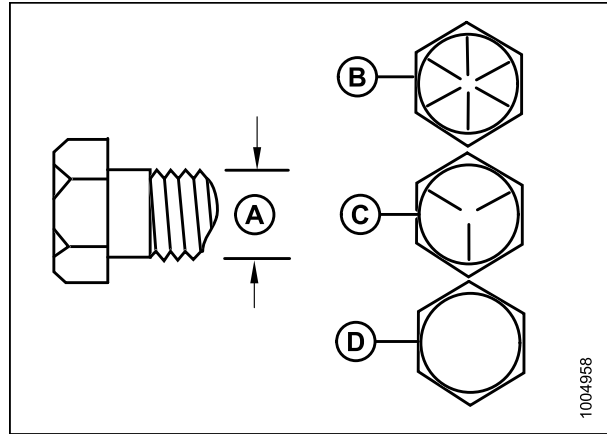

Figure 2.2: Bolt Grades

A - Nominal Size
C - SAE-5

B - SAE-8
D - SAE-2

Table 2.3 SAE Grade 8 Bolt and Grade 8 Distorted Thread Nut

Nominal Size (A)	Torque (ft-lbf) (*in-lbf)		Torque (N-m)	
	Min.	Max.	Min.	Max.
1/4-20	*150	*165	16.8	18.6
5/16-18	18	19	24	26
3/8-16	31	34	42	46
7/16-14	50	55	67	74
1/2-13	76	84	102	113
9/16-12	109	121	148	163
5/8-11	151	167	204	225
3/4-10	268	296	362	400
7/8-9	432	477	583	644
1-8	647	716	874	966

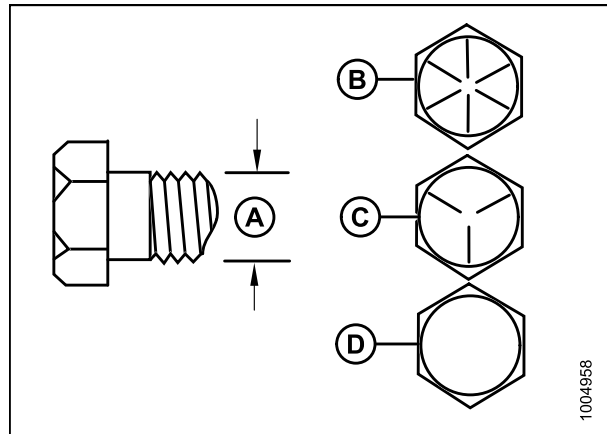

Figure 2.3: Bolt Grades

A - Nominal Size
C - SAE-5

B - SAE-8
D - SAE-2

GENERAL INFORMATION

Table 2.4 SAE Grade 8 Bolt and Grade 8 Free Spinning Nut

Nominal Size (A)	Torque (ft-lbf) (*in-lbf)		Torque (N-m)	
	Min.	Max.	Min.	Max.
1/4-20	*150	*165	16.8	18.6
5/16-18	26	28	35	38
3/8-16	46	50	61	68
7/16-14	73	81	98	109
1/2-13	111	123	150	166
9/16-12	160	177	217	239
5/8-11	221	345	299	330
3/4-10	393	435	531	587
7/8-9	633	700	855	945
1-8	863	954	1165	1288

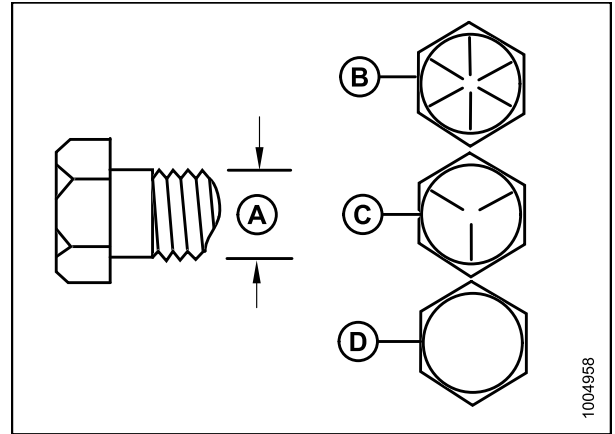

Figure 2.4: Bolt Grades

A - Nominal Size
C - SAE-5

B - SAE-8
D - SAE-2

2.2.2 Metric Bolt Specifications

Table 2.5 Metric Class 8.8 Bolts and Class 9 Free Spinning Nut

Nominal Size (A)	Torque (ft-lbf) (*in-lbf)		Torque (N-m)	
	Min.	Max.	Min.	Max.
3-0.5	*13	*14	1.4	1.6
3.5-0.6	*20	*22	2.2	2.5
4-0.7	*29	*32	3.3	3.7
5-0.8	*59	*66	6.7	7.4
6-1.0	*101	*112	11.4	12.6
8-1.25	20	23	28	30
10-1.5	40	45	55	60
12-1.75	70	78	95	105
14-2.0	113	124	152	168
16-2.0	175	193	236	261
20-2.5	341	377	460	509
24-3.0	589	651	796	879

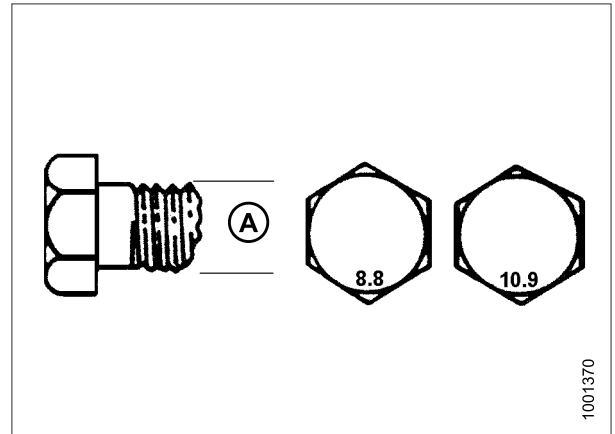

Figure 2.5: Bolt Grades

GENERAL INFORMATION

Table 2.6 Metric Class 8.8 Bolts and Class 9 Distorted Thread Nut

Nominal Size (A)	Torque (ft-lbf) (*in-lbf)		Torque (N-m)	
	Min.	Max.	Min.	Max.
3-0.5	*9	*10	1	1.1
3.5-0.6	*14	*15	1.5	1.7
4-0.7	*20	*22	2.3	2.5
5-0.8	*40	*45	4.5	5
6-1.0	*69	*76	7.7	8.6
8-1.25	*167	*185	18.8	20.8
10-1.5	28	30	37	41
12-1.75	48	53	65	72
14-2.0	77	85	104	115
16-2.0	119	132	161	178
20-2.5	233	257	314	347
24-3.0	402	444	543	600

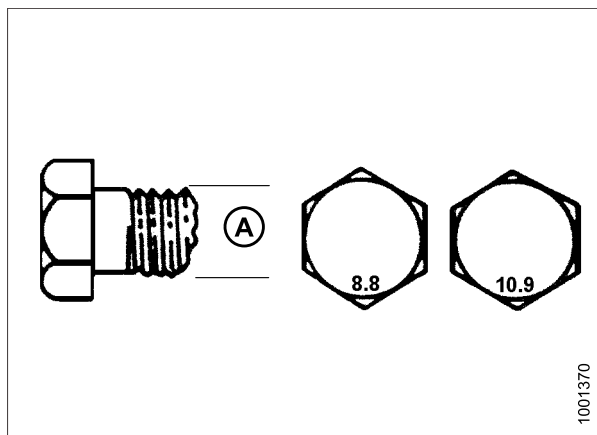

Figure 2.6: Bolt Grades

Table 2.7 Metric Class 10.9 Bolts and Class 10 Free Spinning Nut

Nominal Size (A)	Torque (ft-lbf) (*in-lbf)		Torque (N-m)	
	Min.	Max.	Min.	Max.
3-0.5	*18	*19	1.8	2
3.5-0.6	*27	*30	2.8	3.1
4-0.7	*41	*45	4.2	4.6
5-0.8	*82	*91	8.4	9.3
6-1.0	*140	*154	14.3	15.8
8-1.25	28	31	38	42
10-1.5	56	62	75	83
12-1.75	97	108	132	145
14-2.0	156	172	210	232
16-2.0	242	267	326	360
20-2.5	472	521	637	704
24-3.0	815	901	1101	1217

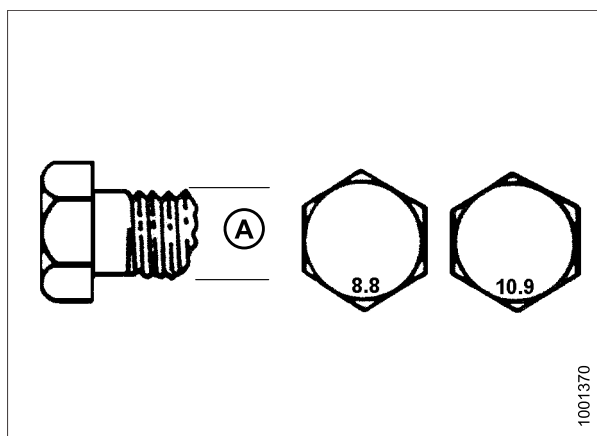

Figure 2.7: Bolt Grades

GENERAL INFORMATION

Table 2.8 Metric Class 10.9 Bolts and Class 10 Distorted Thread Nut

Nominal Size (A)	Torque (ft·lbf) (*in·lbf)		Torque (N·m)	
	Min.	Max.	Min.	Max.
3-0.5	*12	*13	1.3	1.5
3.5-0.6	*19	*21	2.1	2.3
4-0.7	*28	*31	3.1	3.4
5-0.8	*56	*62	6.3	7
6-1.0	*95	*105	10.7	11.8
8-1.25	19	21	26	29
10-1.5	38	42	51	57
12-1.75	66	73	90	99
14-2.0	106	117	143	158
16-2.0	165	182	222	246
20-2.5	322	356	434	480
24-3.0	556	614	750	829

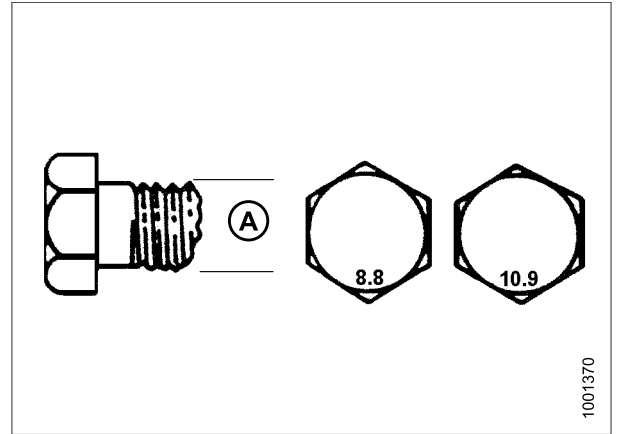

Figure 2.8: Bolt Grades

2.2.3 Metric Bolt Specifications Bolting into Cast Aluminum

Table 2.9 Metric Bolt Bolting into Cast Aluminum

Nominal Size (A)	Bolt Torque			
	8.8 (Cast Aluminum)		10.9 (Cast Aluminum)	
	ft-lbf	N-m	ft-lbf	N-m
M3	–	–	1	–
M4	–	–	2.6	4
M5	–	–	5.5	8
M6	6	9	9	12
M8	14	20	20	28
M10	28	40	40	55
M12	52	70	73	100
M14	–	–	–	–
M16	–	–	–	–

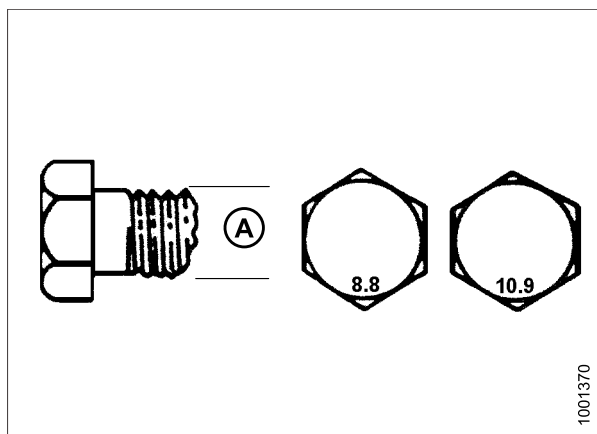

Figure 2.9: Bolt Grades

2.2.4 Flare-Type Hydraulic Fittings

1. Check flare (A) and flare seat (B) for defects that might cause leakage.
2. Align tube (C) with fitting (D), and thread nut (E) onto fitting without lubrication until contact has been made between the flared surfaces.
3. Torque the fitting nut (E) to the specified number of flats from finger tight (FFFT) or to a given torque value shown in [Table 2.10 Flare-Type Hydraulic Tube Fittings, page 17](#).
4. Use two wrenches to prevent fitting (D) from rotating. Place one wrench on the fitting body (D), and tighten nut (E) with the other wrench to the torque shown.
5. Assess the final condition of the connection.

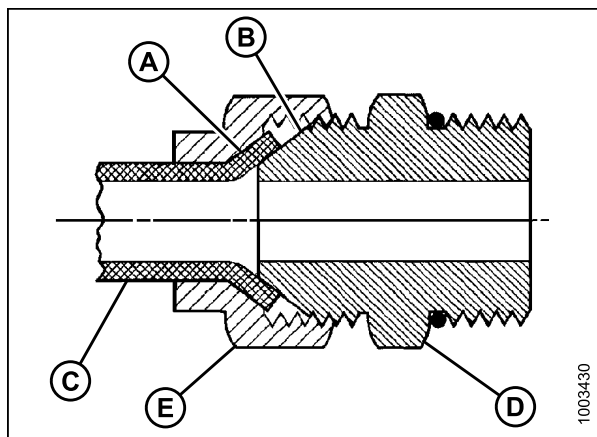

Figure 2.10: Hydraulic Fitting

GENERAL INFORMATION

Table 2.10 Flare-Type Hydraulic Tube Fittings

SAE No.	Tube Size O.D.(in.)	Thread Size (in.)	Nut Size acrossFlats (in.)	Torque Value ¹		Flats from Finger Tight (FFFT)	
				ft-lbf	N-m	Flats	Turns
3	3/16	3/8	7/16	6	8	1	1/6
4	1/4	7/16	9/16	9	12	1	1/6
5	5/16	1/2	5/8	12	16	1	1/6
6	3/8	9/16	11/16	18	24	1	1/6
8	1/2	3/4	7/8	34	46	1	1/6
10	5/8	7/8	1	46	62	1	1/6
12	3/4	1-1/16	1-1/4	75	102	3/4	1/8
14	7/8	1-3/8	1-3/8	90	122	3/4	1/8
16	1	1-5/16	1-1/2	105	142	3/4	1/8

1. Torque values shown are based on lubricated connections as in reassembly.

2.2.5 O-Ring Boss (ORB) Hydraulic Fittings (Adjustable)

1. Inspect O-ring (A) and seat (B) for dirt or obvious defects.
2. Back off the lock nut (C) as far as possible. Ensure that washer (D) is not loose and is pushed toward the lock nut (C) as far as possible.
3. Check that O-ring (A) is **NOT** on the threads and adjust if necessary.
4. Apply hydraulic system oil to the O-ring (A).

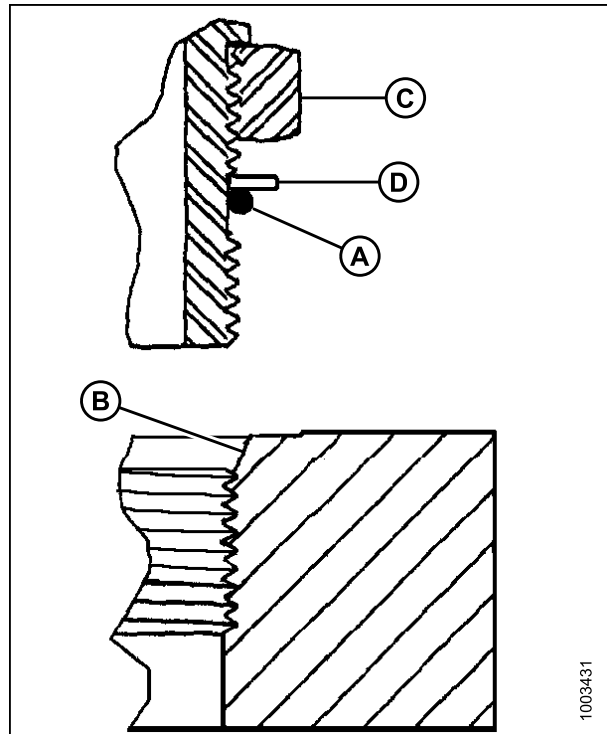

Figure 2.11: Hydraulic Fitting

5. Install fitting (B) into port until back up washer (D) and O-ring (A) contact the part face (E).
6. Position angle fittings by unscrewing no more than one turn.
7. Turn lock nut (C) down to washer (D) and tighten to torque shown. Use two wrenches, one on fitting (B) and the other on lock nut (C).
8. Check the final condition of the fitting.

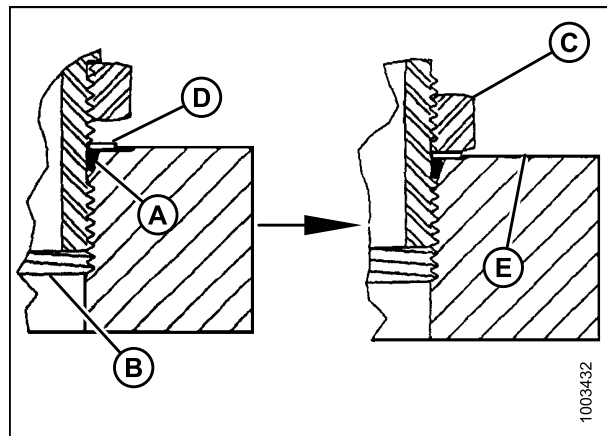

Figure 2.12: Hydraulic Fitting

GENERAL INFORMATION

Table 2.11 O-Ring Boss (ORB) Hydraulic Fittings (Adjustable)

SAE Dash Size	Thread Size (in.)	Torque Value ²	
		ft·lbf (*in·lbf)	N·m
-3	3/8-24	106–115	12–13
-4	7/16–20	14–15	19–21
-5	1/2–20	15–24	21–33
-6	9/16–18	19–21	26–29
-8	3/4–16	34–37	46–50
-10	7/8–14	55–60	75–82
-12	1-1/16-12	88–97	120–132
-14	1-3/8-12	113–124	153–168
-16	1-5/16-12	130–142	176–193
-20	1-5/8-12	163–179	221–243
-24	1-7/8-12	199–220	270–298

2. Torque values shown are based on lubricated connections as in reassembly.

GENERAL INFORMATION

2.2.6 O-Ring Boss (ORB) Hydraulic Fittings (Non-Adjustable)

1. Inspect O-ring (A) and seat (B) for dirt or obvious defects.
2. Check that O-ring (A) is **NOT** on the threads and adjust if necessary.
3. Apply hydraulic system oil to the O-ring.
4. Install fitting (C) into port until fitting is hand tight.
5. Torque fitting (C) according to the values in Table 2.12 *O-Ring Boss (ORB) Hydraulic Fittings (Non-Adjustable)*, page 20.
6. Check the final condition of the fitting.

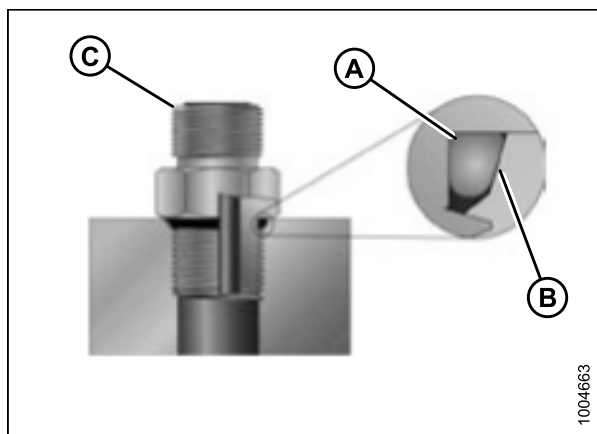

Figure 2.13: Hydraulic Fitting

Table 2.12 O-Ring Boss (ORB) Hydraulic Fittings (Non-Adjustable)

SAE Dash Size	Thread Size (in.)	Torque Value ³	
		ft·lbf (*in·lbf)	N·m
-3	3/8-24	106–115	12–13
-4	7/16–20	14–15	19–21
-5	1/2–20	15–24	21–33
-6	9/16–18	19–21	26–29
-8	3/4–16	34–37	46–50
-10	7/8–14	55–60	75–82
-12	1-1/16-12	88–97	120–132
-14	1-3/8-12	113–124	153–168
-16	1-5/16-12	130–142	176–193
-20	1-5/8-12	163–179	221–243
-24	1-7/8-12	199–220	270–298

3. Torque values shown are based on lubricated connections as in reassembly.

2.2.7 O-Ring Face Seal (ORFS) Hydraulic Fittings

1. Check components to ensure that the sealing surfaces and fitting threads are free of burrs, nicks, scratches, or any foreign material.



Figure 2.14: Hydraulic Fitting

2. Apply hydraulic system oil to the O-ring (B).
3. Align the tube or hose assembly so that the flat face of the sleeve (A) or (C) comes in full contact with O-ring (B).
4. Thread tube or hose nut (D) until hand-tight. The nut should turn freely until it is bottomed out.
5. Torque fittings according to the values in Table [2.13 O-Ring Face Seal \(ORFS\) Hydraulic Fittings, page 22](#).

NOTE:

If applicable, hold the hex on the fitting body (E) to prevent rotation of fitting body and hose when tightening the fitting nut (D).

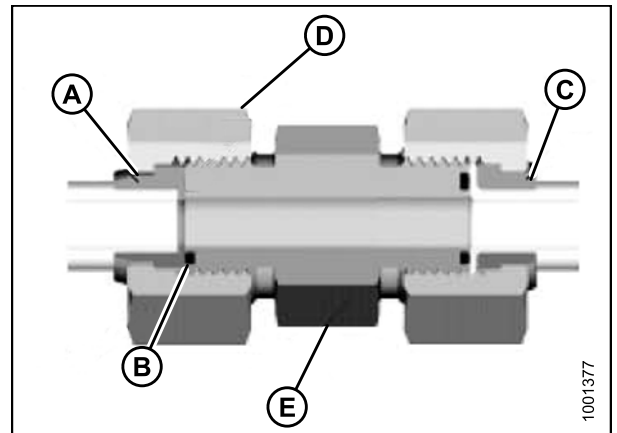

Figure 2.15: Hydraulic Fitting

6. Use three wrenches when assembling unions or joining two hoses together.
7. Check the final condition of the fitting.

GENERAL INFORMATION

Table 2.13 O-Ring Face Seal (ORFS) Hydraulic Fittings

SAE Dash Size	Thread Size (in.)	Torque Value ⁴	
		ft·lbf (*in·lbf)	N·m
-3	Note ⁵	–	–
-4	9/16–18	18–21	25–28
-5	Note ⁵	–	–
-6	11/16-16	29–32	40–44
-8	13/16-16	41–45	55–61
-10	1–14	59–65	80–88
-12	1-3/16-12	85–94	115–127
-14	Note ⁵	–	–
-16	1-7/16-12	111–122	150–165
-20	1-11/16-12	151–167	205–226
-24	2–12	232–256	315–347
-32	2-1/2-12	376–414	510–561

4. Torque values and angles shown are based on lubricated connection as in reassembly.

5. O-ring face seal type end not defined for this tube size.

GENERAL INFORMATION

2.3 Specifications

NOTE:

Specifications and design are subject to change without notice or obligation to revise previously sold units.

Item		Specification			
Frame and Structure					
Total Weight (estimated)		1700 lb (770 kg)			
Carrier		MacDon M150, M155, and M200 Self-Propelled Windrowers			
Manual Storage		In Windrower Cab			
Drives					
Main Conditioner		3.16 cu in. (51.83 cc) Hydraulic Motor with 1.29 cu in. (21.14 cc) Flow Divider			
Feed Deck		4.0 cu in. (65 cc) Hydraulic Motor with 921 psi Relief			
Connections		Flat Faced Quick Attach Couplers – Connect Under Pressure			
Normal Operating Pressure	Conditioner	2500–3000 psi (17.0–20.7 MPa)			
	Feed Deck	600 psi (4.1 MPa)			
Conditioner					
Drive		Hydraulic Motor To Belt Driven Roll To Open Timing Gear System			
Roll Type		Intermeshing Steel Bars			
Roll Diameter		9.17 in. (233 mm)/6.63 in. (168.4 mm) OD Tube			
Roll Length		72 in. (1830 mm)			
Header Size		15 ft.	20 ft. and 25 ft.	30 ft.	35 ft.
Roll Speed		772–977 rpm	720–874 rpm	695–927 rpm	695–868 rpm
Feed Draper Speed		437–553 fpm	407–495 fpm	393–525 fpm	393–491 fpm
Swath Width		36–102 in. (915–2540 mm)			
Forming Shields		Header Mounted Tractor Supported Adjustable Forming Shield System			

NOTE:

To avoid excessive vibration and poor performance, the HC10 Hay Conditioner should **NOT** be attached to single-knife drive headers. **The HC10 Hay Conditioner is NOT intended for use with the M105 or M205 Self-Propelled Windrower power unit.**

GENERAL INFORMATION

2.4 Conversion Chart

Table 2.14 Conversion Chart

Quantity	Inch-Pound Units		Factor	SI Units (Metric)	
	Unit Name	Abbreviation		Unit Name	Abbreviation
Area	Acres	acres	$\times 0.4047 =$	Hectares	ha
Flow	US Gallons per Minute	gpm	$\times 3.7854 =$	Liters per Minute	L/min
Force	Pounds Force	lbf	$\times 4.4482 =$	Newtons	N
Length	Inch	in.	$\times 25.4 =$	Millimeters	mm
	Foot	ft.	$\times 0.305 =$	Meters	m
Power	Horsepower	hp	$\times 0.7457 =$	Kilowatts	kW
Pressure	Pounds per Square Inch	psi	$\times 6.8948 =$	Kilopascals	kPa
			$\times .00689 =$	Megapascals	MPa
			$\div 14.5038 =$	Bar (Non-SI)	bar
Torque	Pound Feet or Foot Pounds	ft·lbf	$\times 1.3558 =$	Newton Meters	N·m
	Pound Inches or Inch Pounds	in·lbf	$\times 0.1129 =$	Newton Meters	N·m
Temperature	Degrees Fahrenheit	°F	$(^{\circ}\text{F}-32) \times 0.56 =$	Celsius	°C
Velocity	Feet per Minute	ft/min	$\times 0.3048 =$	Meters per Minute	m/min
	Feet per Second	ft/s	$\times 0.3048 =$	Meters per Second	m/s
	Miles per Hour	mph	$\times 1.6063 =$	Kilometres per Hour	km/h
Volume	US Gallons	US gal	$\times 3.7854 =$	Liters	L
	Ounces	oz.	$\times 29.5735 =$	Milliliters	ml
	Cubic Inches	in. ³	$\times 16.3871 =$	Cubic Centimetres	cm ³ or cc
Weight	Pounds	lbs	$\times 0.4536 =$	Kilograms	kg

2.5 Component Identification

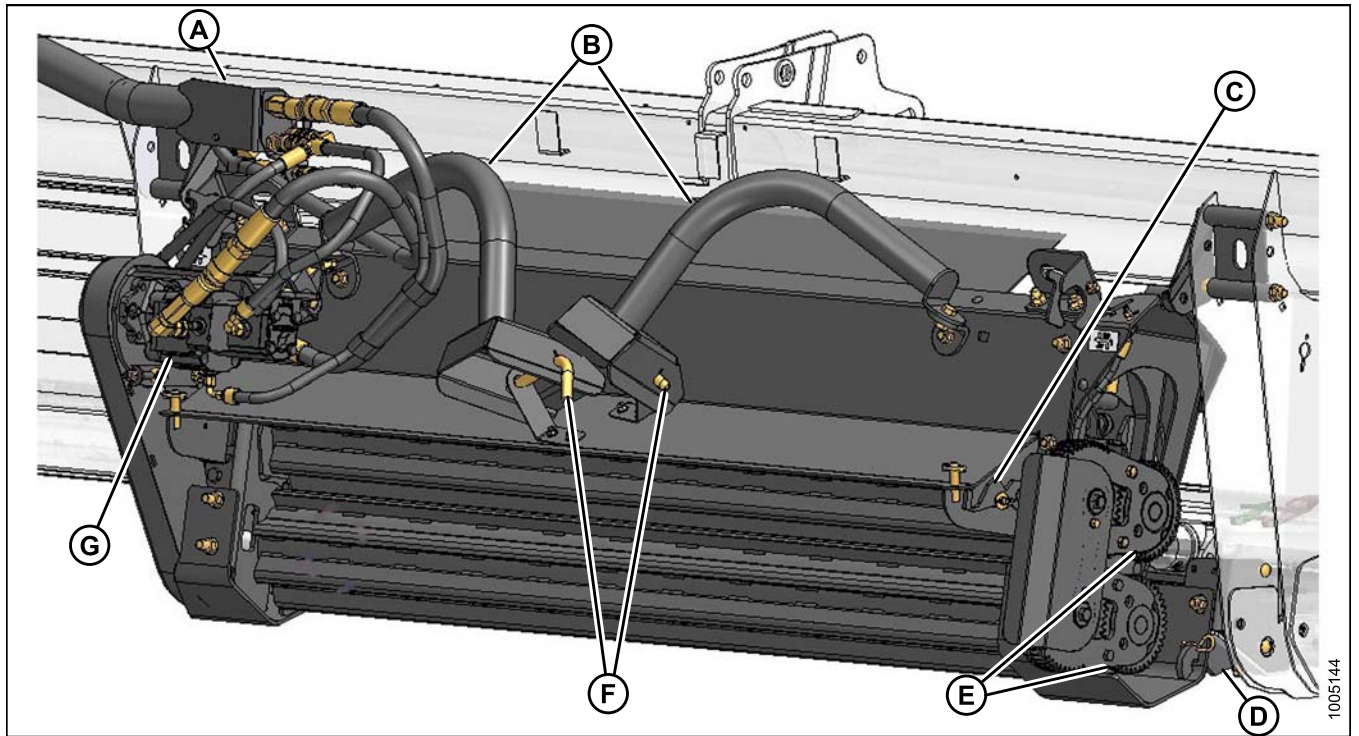

Figure 2.16: Back View of Hay Conditioner Installed in Header

A - Hydraulics To Header
E - Timing Gears

B - Lift Arms
F - L-Pins

C - Roll Timing Tool
G - Hydraulic Motor

D - Stand

GENERAL INFORMATION

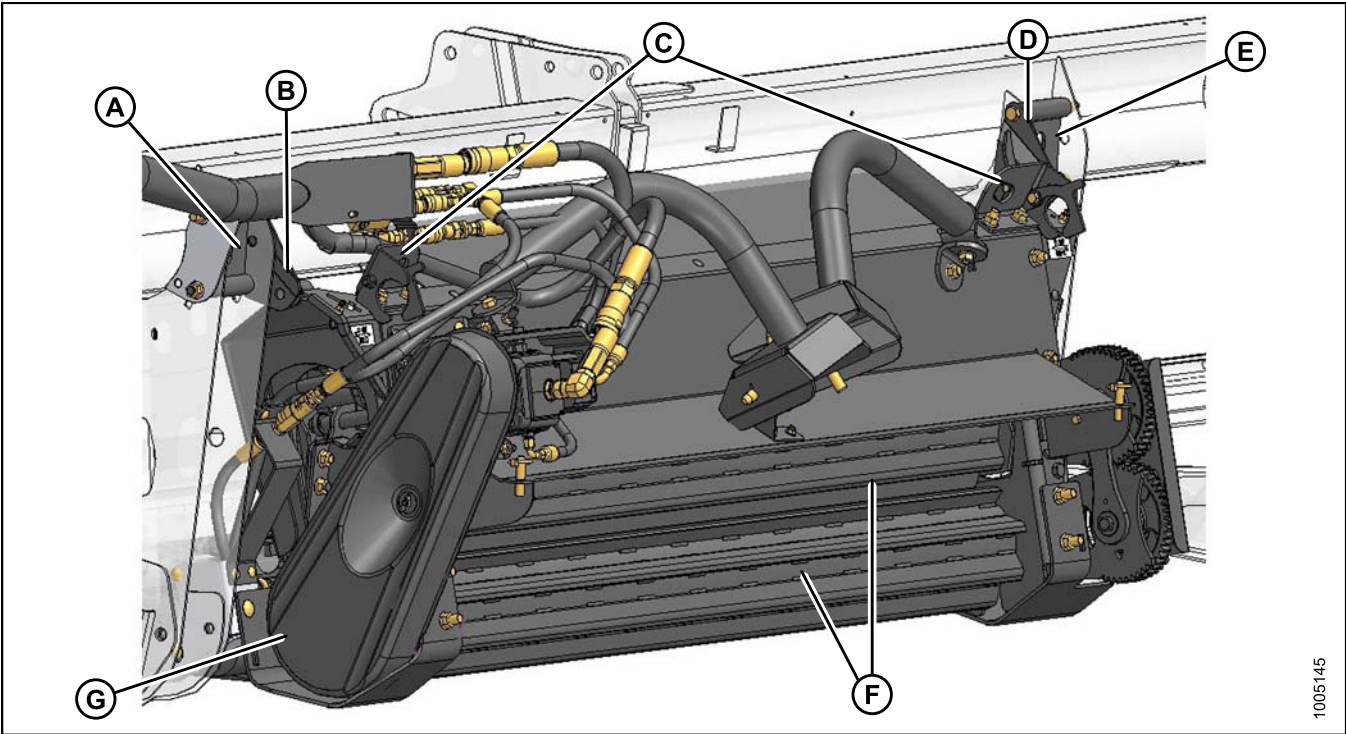

1005145

Figure 2.17: Back View of Hay Conditioner Installed in Header

A - Spacer
E - Spacer

B - Mounting Bracket
F - Rolls

C - Lifting Lugs
G - Drive Belt Shield

D - Mounting Bracket

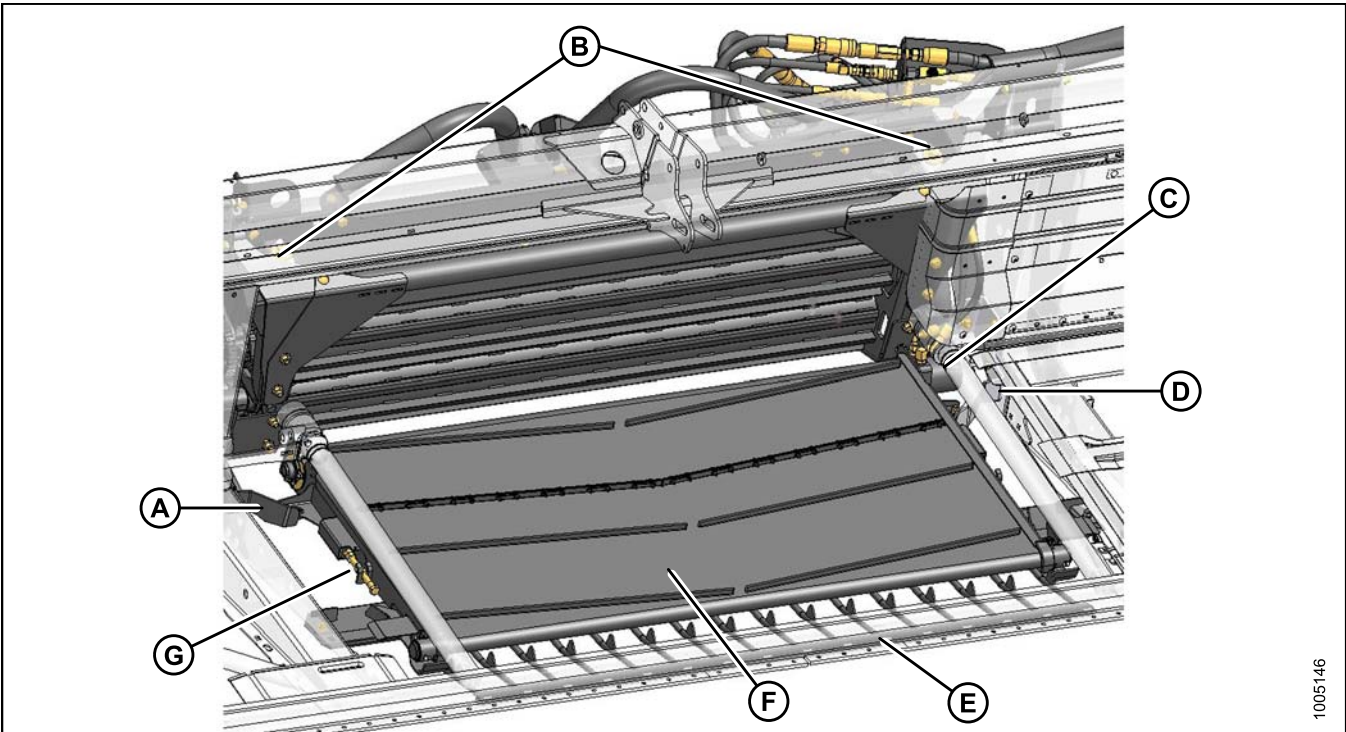

1005146

Figure 2.18: Front View of Hay Conditioner Installed in Header

A - Mounting Bracket
E - Rock Grate

B - Roll Gap Adjusters
F - Feed Deck

C - Feed Deck Motor
G - Draper Tension Adjusters (2)

D - Mounting Bracket

GENERAL INFORMATION

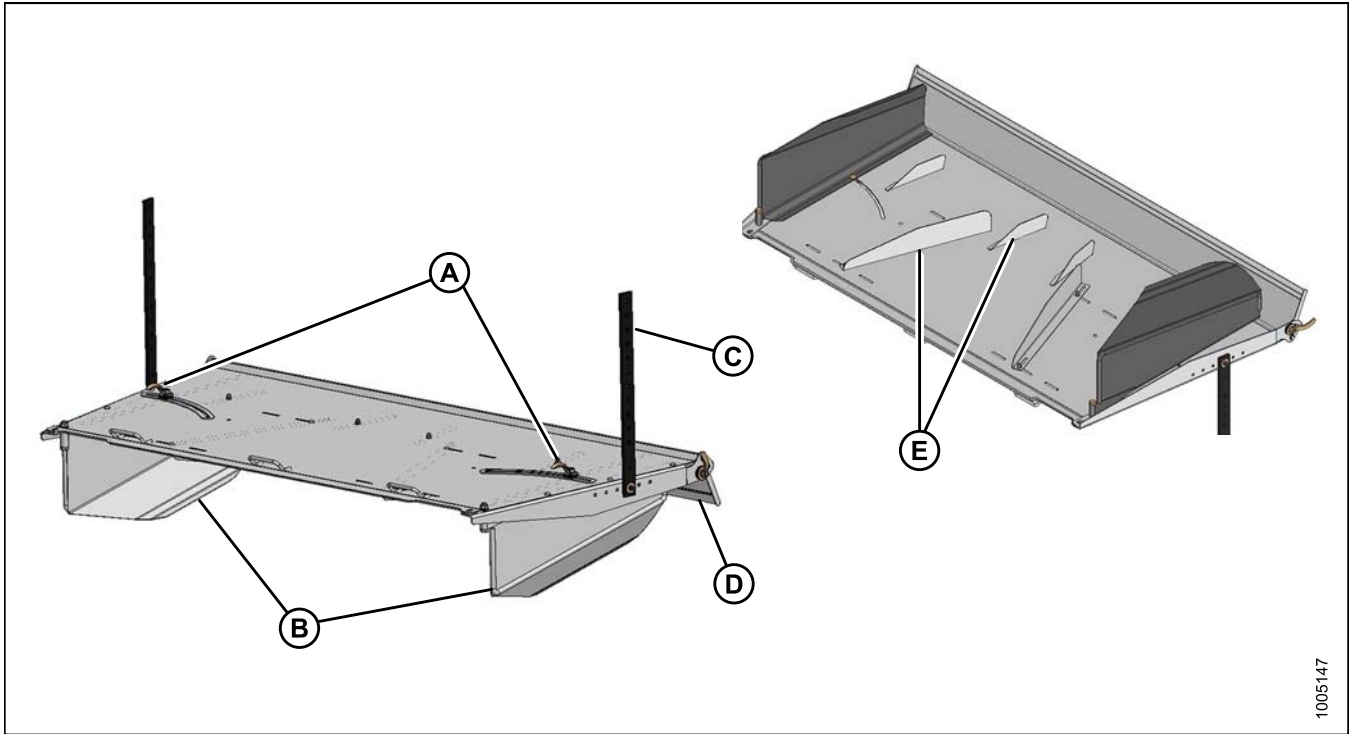

1005147

Figure 2.19: Swath Forming Shield

A - Side Deflector Adjusters
E - Deflector Fins

B - Side Deflectors

C - Height Adjust Strap

D - Fluffer Shield

3 Unloading and Assembly

To unload and assemble an HC10 Hay Conditioner, follow each of the procedures in this chapter in order.

3.1 Unloading the Hay Conditioner

CAUTION

To avoid injury to bystanders from being struck by machinery, do NOT allow people to stand in unloading area.

CAUTION

Equipment used for unloading must meet or exceed the requirements specified below. Using inadequate equipment may result in vehicle tipping or machine damage.

Lifting Vehicle	
Minimum Lifting Capacity ⁶	2000 lb (908 kg)
Minimum Fork Length	60 in. (1524 mm)

IMPORTANT:

Forklifts are normally rated for a load located 24 in. (610 mm) ahead of back end of the forks. To obtain the forklift capacity at 48 in. (1220 mm), check with your forklift distributor.

WARNING

Be sure forks are secure before moving away from load. Stand clear when lifting.

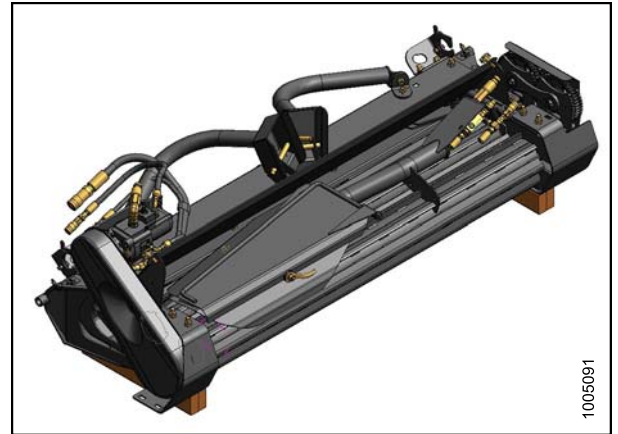

Figure 3.1: Hay Conditioner Bundle #B4798

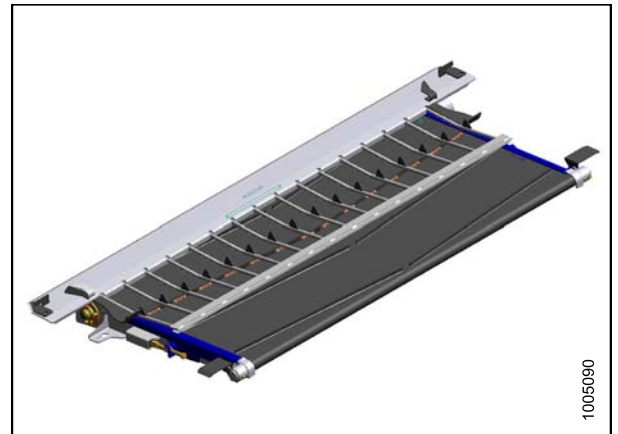

Figure 3.2: Feed Deck Bundle #B4799

6. At 48 in. (1220 mm) from back end of forks.

UNLOADING AND ASSEMBLY

To unload the hay conditioner, follow these steps:

1. Remove hauler's tie down straps and chains.
2. Use forklift to lift the first of three pallets of hay conditioner components off of the trailer deck.
3. Back up until unit clears trailer and slowly lower to 6 in. (150 mm) from ground.
4. Take to storage or setup area.
5. Set pallet down securely on level ground.
6. Check for shipping damage and missing parts.
7. Repeat above steps for remaining pallets.

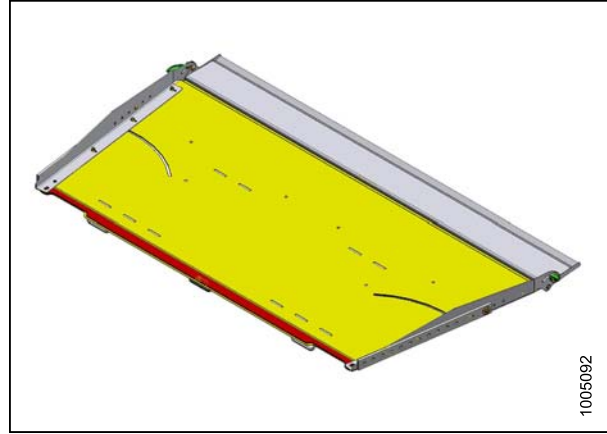

Figure 3.3: Forming Shield Bundle #B4800

3.2 Preparing the Header

To prepare the draper header for installation of the hay conditioner, follow these steps:

1. Adjust the header stand (A) to mid-position.
2. Trim poly deflector along creased line (A) on back of poly for proper fit up to conditioner.



Figure 3.4: Header Stand

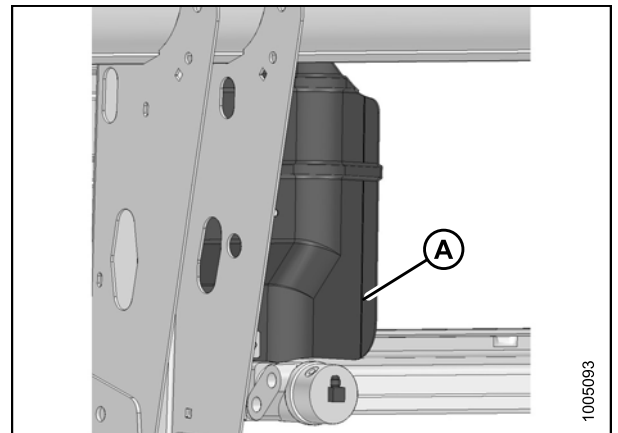

Figure 3.5: Poly Deflector

3.3 Installing the Rock Grate

To install the rock grate, follow these steps:

1. Unpack feed deck / rock grate bundle.
2. Position rock grate into center area of header.
3. Lift rock grate (A) and position the rear tabs (C) so they slide over the header leg flanges.
4. Position the front lip (B) of rock grate (A) in front of the bottom edge of the cutterbar and slide forward so it engages the cutterbar.
5. If the header is equipped with cutterbar poly, set the rock grate on top of the poly in front of the cutterbar, then push down and forward to seat the rock grate onto the cutterbar.
6. Ensure rock grate is completely pushed forward and secure with two bolts (A) installed from underside.
7. Tighten both bolts.

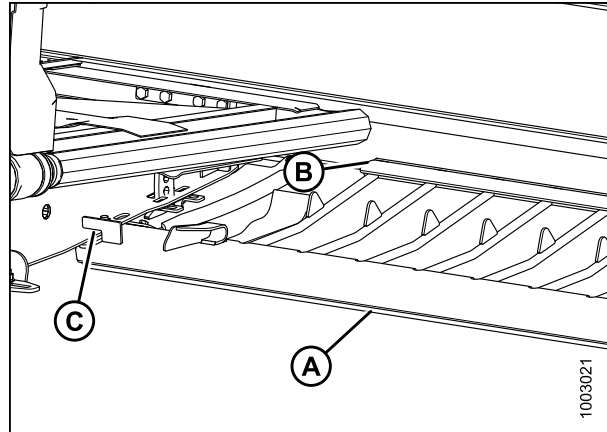

Figure 3.6: Rock Grate

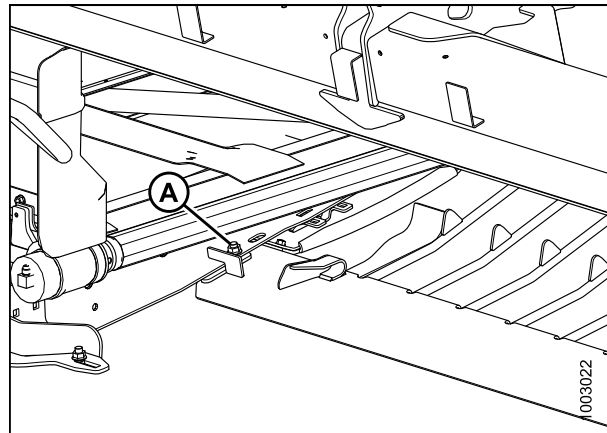

Figure 3.7: Rock Grate

3.4 Installing Deck Brackets

To install the deck brackets onto the header, follow these steps:

1. Install the two lower brackets (A) onto the inside of both center header legs with two bolts and nuts (B) in each bracket.

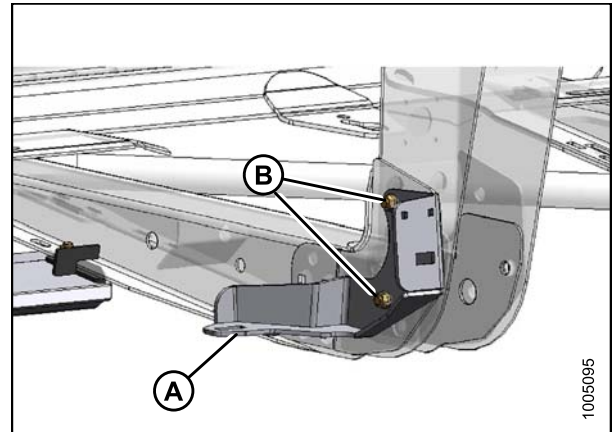

Figure 3.8: Lower Deck Brackets

2. Install right-hand upper bracket (A) and spacer (B) on the right-hand center leg as shown in Figure 3.9: [15-ft Header Shown, page 33](#), and install nut (C).

NOTE:

For headers with a sheet metal hose cover, install bolts from the outboard side.

3. Install the other bolt through the bracket and spacer and secure with a nut (D).
4. Tighten both bolts.

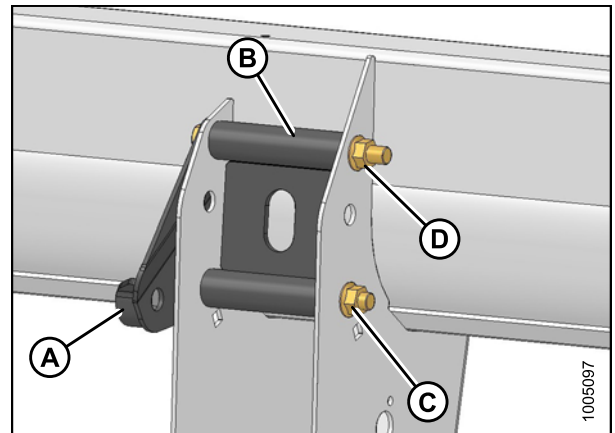

Figure 3.9: 15-ft Header Shown

5. Install the left-hand upper bracket (A) and spacer (B) onto the inboard side of left-hand center leg as shown in Figure 3.10: [Upper Bracket – LH, page 33](#).

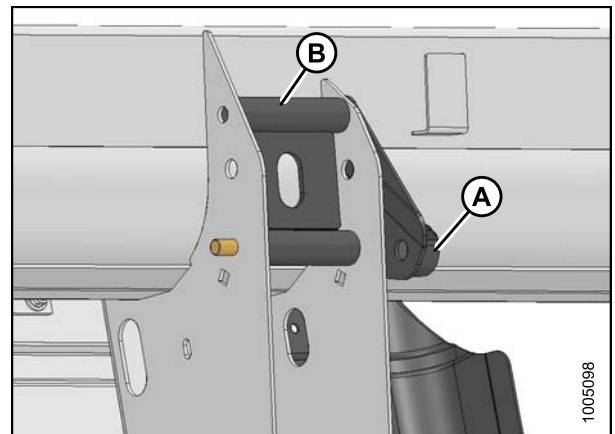

Figure 3.10: Upper Bracket – LH

UNLOADING AND ASSEMBLY

6. Remove the hose guide (A) located near the left-hand center leg. (For 20-foot and larger headers, remove this support from its mounting position on sheet metal hose cover.)

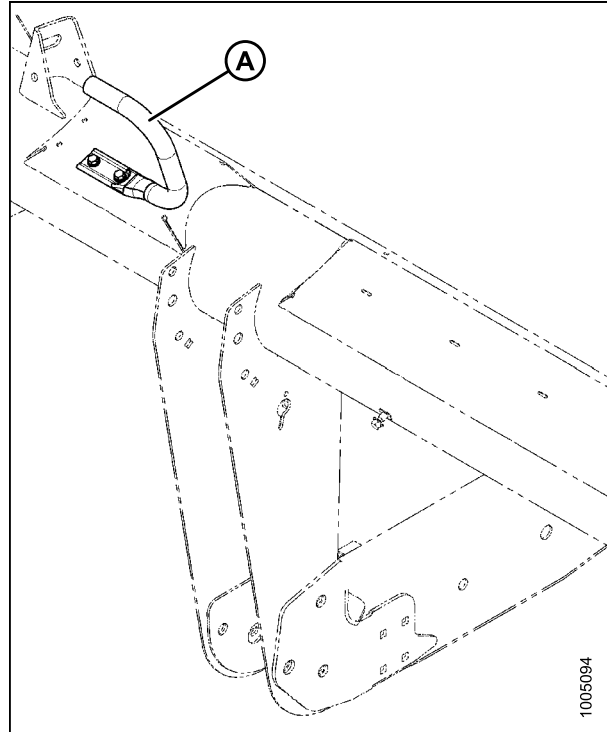

Figure 3.11: 15-ft. Header Shown

7. Attach hose assembly (A) onto the left-hand center leg and install nut on lower bolt (C). Ensure correct hole is used when attaching hose assembly (use hole [D] for 15-foot headers).

NOTE:

For headers with a sheet metal hose cover, install bolts from the outboard side.

8. Install other bolt (B) through bracket, spacer, and hose assembly and secure with a nut.
9. Tighten both bolts.

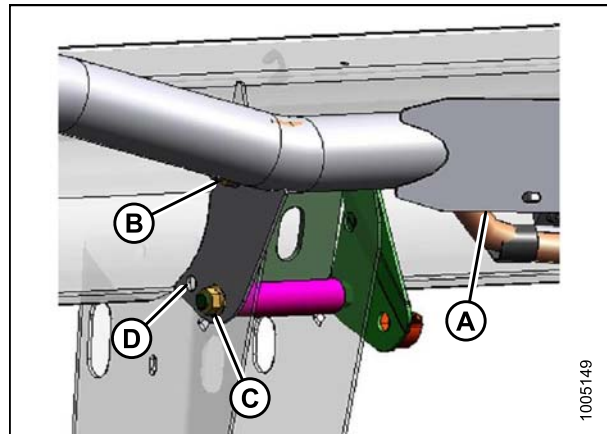

Figure 3.12: 20-35-ft. Header Shown

3.5 Installing the Feed Deck

To install the feed deck, follow these steps:

1. Slide feed deck (A) under header opening from the rear. Deck drive motor faces aft.

2. Set front of deck (A) onto the rock grate and slide the feed deck forward until the locating pins (B) reach the pockets on the rock grate.

3. Lift the rear of the feed deck so the mounts on the deck clear the brackets on the leg and slide deck forward until mounting pins are fully positioned inside the pockets.

4. Install two 1/2 x 1-1/4 in. long carriage bolts at rear mounting brackets.

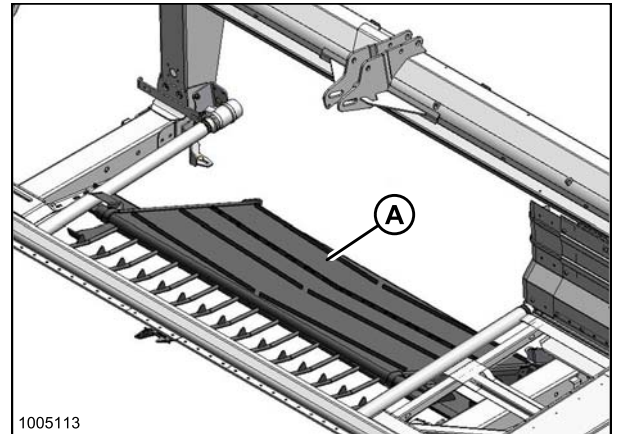

Figure 3.13: Feed Deck

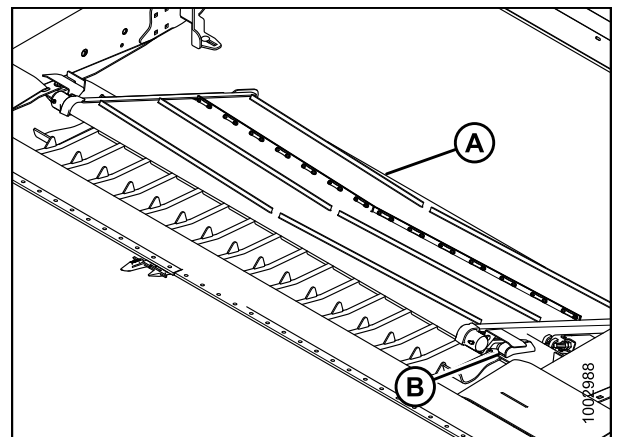

Figure 3.14: Feed Deck

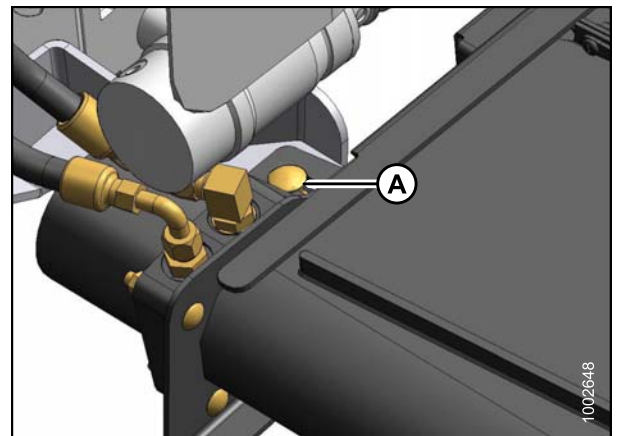

Figure 3.15: Feed Deck – LH Side

UNLOADING AND ASSEMBLY

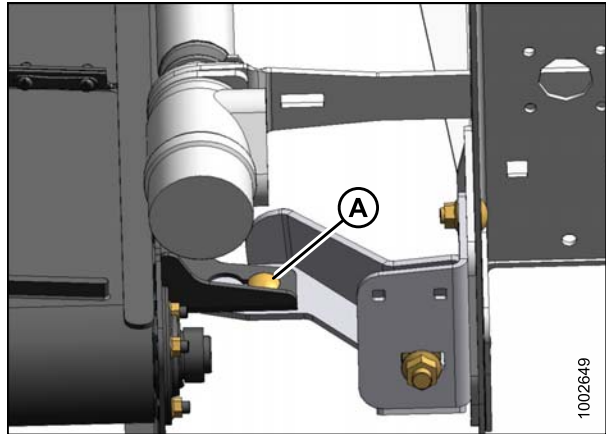

Figure 3.16: Feed Deck – RH Side

5. Attach the hose bracket (A) to the mounting bracket with two 3/8 x 1.0 in. long carriage bolts (B).
6. Adjust header side drapers to overlap feed deck by 2-1/2 to 3 in. (65 to 75 mm). Refer to header operator's manual for procedure.

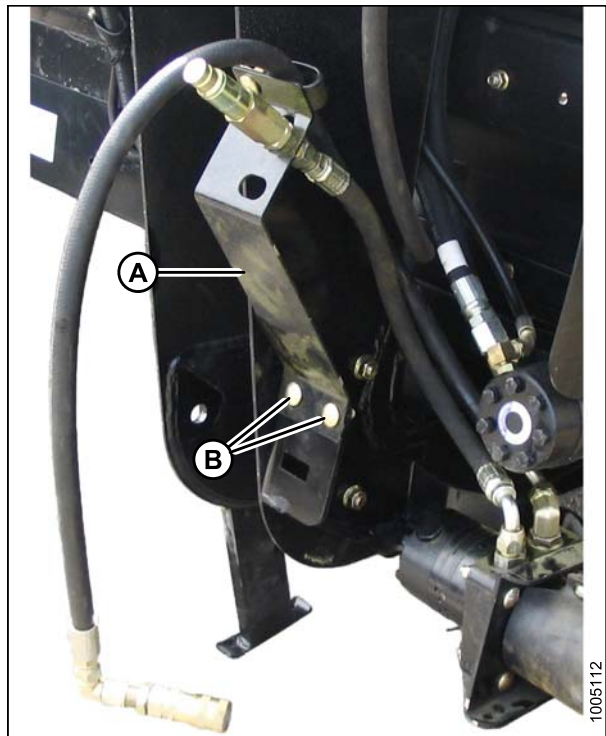

Figure 3.17: Hose Bracket

3.6 Installing the Conditioner

There are two methods for installing the conditioner:

- The lifting method
- The windrower method

3.6.1 Installing Conditioner: Lifting Method

CAUTION

Equipment used for unloading must meet or exceed the requirements specified below. Using inadequate equipment may result in vehicle tipping or machine damage.

Lifting Vehicle	
Minimum Lifting Capacity ⁷	2000 lb (908 kg)
Minimum Fork Length	60 in. (1524 mm)

IMPORTANT:

Forklifts are normally rated for a load located 24 in. (610 mm) ahead of back end of the forks. To obtain the forklift capacity at 48 in. (1220 mm), check with your forklift distributor.

Chain Type	Overhead Lifting Quality (1/2 inch)
Minimum Working Load	5000 lb (2270 kg)

To install the conditioner using the lifting method, follow these steps:

1. Attach chain to lifting brackets (A) on conditioner and secure chain to lifting device (B).
2. Lift conditioner to upright position.
3. Remove shipping blocks if present.
4. Position conditioner into header opening from the rear.

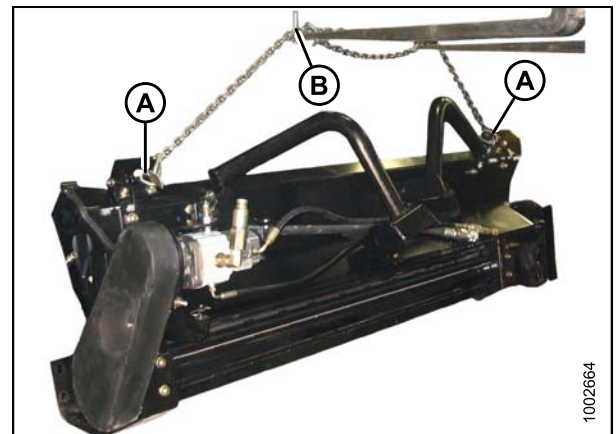

Figure 3.18: Conditioner and Lifting Brackets

⁷ At 48 in. (1220 mm) from back end of forks.

UNLOADING AND ASSEMBLY

5. Carefully lower the windrower lift legs until lugs (A) on conditioner are seated in the U-shaped brackets (B) on header.
6. Ensure the conditioner is seated properly in the brackets and remove the chains.

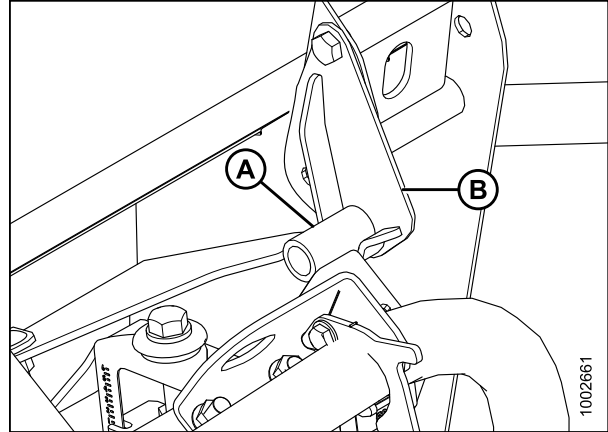

Figure 3.19: Conditioner Lug

7. Install 5/8 in. x 1-1/2 in. carriage bolt (A) in the right-hand lower attachment location.

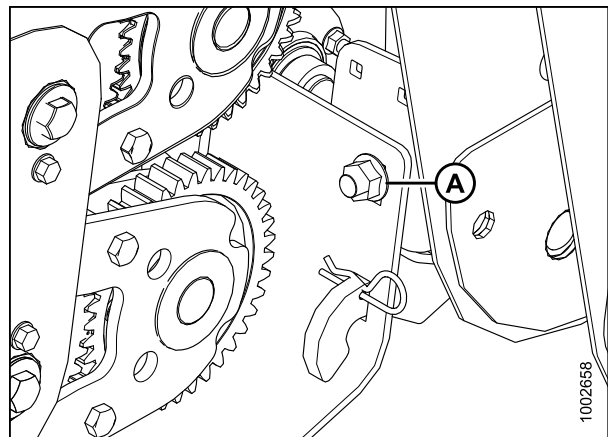

Figure 3.20: Conditioner – RH Side

8. Install 5/8 in. x 1-1/2 in. carriage bolt (A) in the left-hand lower attachment location.

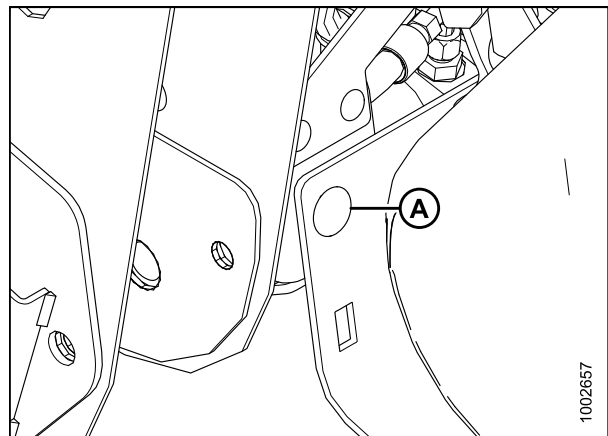

Figure 3.21: Conditioner – LH Side

UNLOADING AND ASSEMBLY

9. Connect the five hydraulic hoses between the conditioner and the header as follows:
 - Small male quick-disconnect from motor to header (A)
 - Large female quick-disconnect from motor to header (B)
 - Small female quick-disconnect from deck to header (C)
 - Small female quick-disconnect from motor to deck (D)
 - Large female quick-disconnect from header to motor (E)

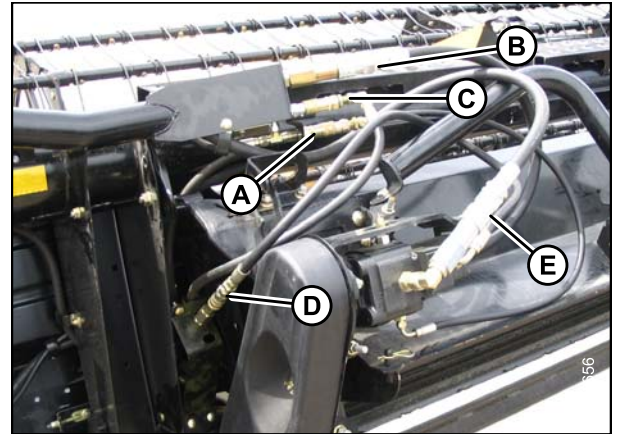

Figure 3.22: Hydraulic Hoses

A - Case Drain
B - Conditioner Motor Pressure
C - Deck Motor Return
D - Deck Motor Pressure
E - Conditioner Motor Return

3.6.2 Installing Conditioner: Windrower Method

To install the conditioner using the windrower method, follow these steps:

1. Lower header stand to mid-position (A).
2. Attach chain (A) to lifting brackets (B) on conditioner and secure chain to lifting device.
3. Lift off of shipping pallet and set conditioner on ground in upright position.



Figure 3.23: Header Stand

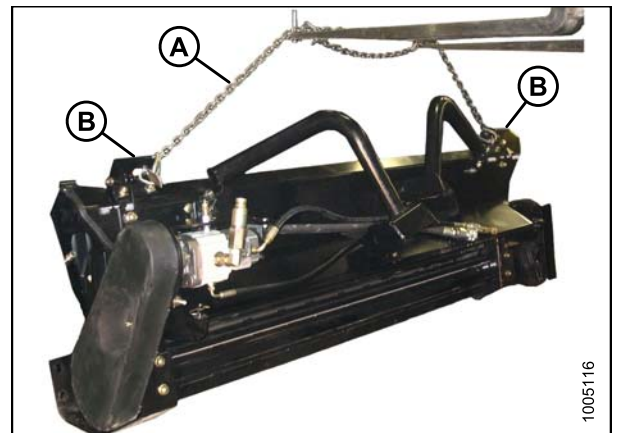

Figure 3.24: Conditioner and Lifting Brackets

UNLOADING AND ASSEMBLY

- Retrieve stand (A) and hairpin (B) from conditioner bundle (MD #B4798) and install stand in slot in base at lower right-hand end of conditioner. Secure stand with hairpin.
- Remove shipping blocks if present.

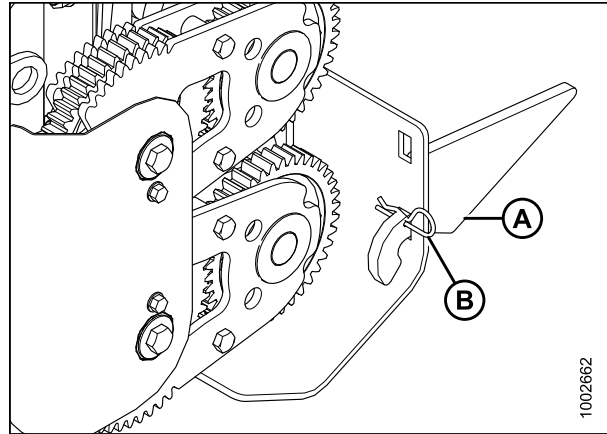

Figure 3.25: Conditioner Stand

- Hardware at lifting arms has been tightened for shipping. Loosen two bolts (A) per side just enough to allow arms (B) to swing out.

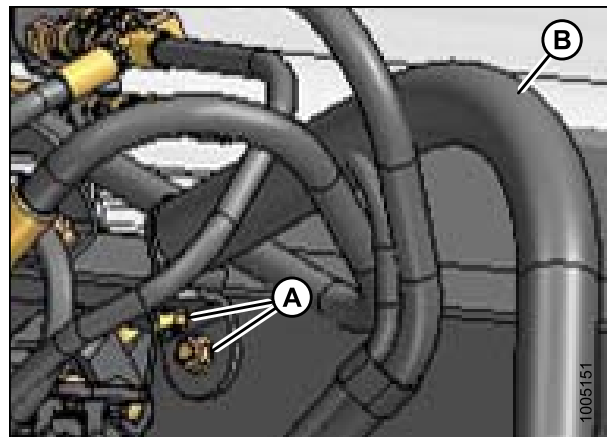

Figure 3.26: Lifting Arm – LH

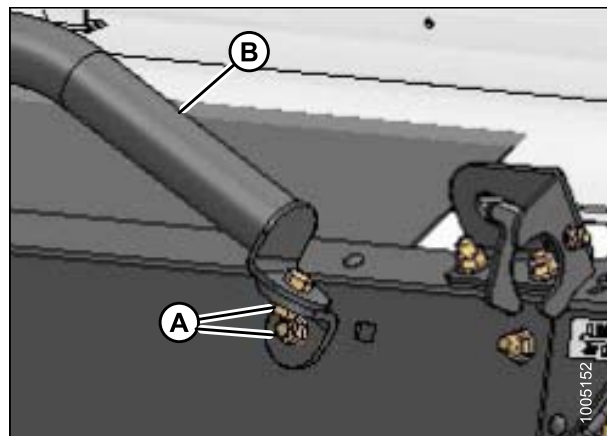

Figure 3.27: Lifting Arm – RH

UNLOADING AND ASSEMBLY

7. Remove L-pins (A) securing lifting arms to conditioner.
(Rotate pins to align key-hole slot.)

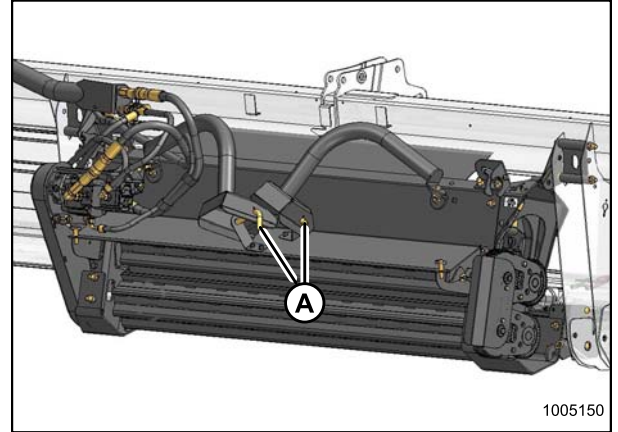

Figure 3.28: Conditioner

8. Swing out lift arms (A) and secure latches.

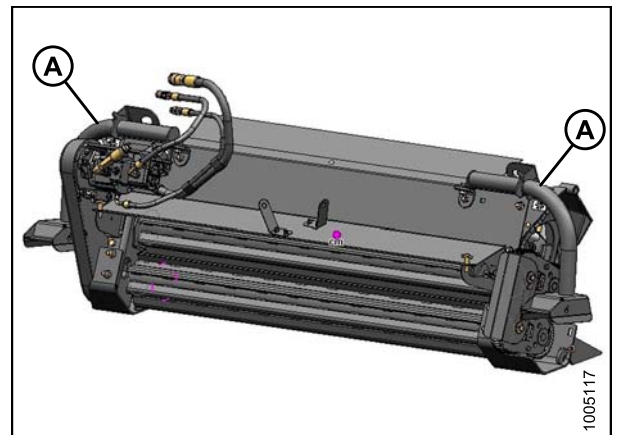

Figure 3.29: Conditioner

9. Position the windrower arms in the lift arm pockets and insert the L-pins (A) for safety.

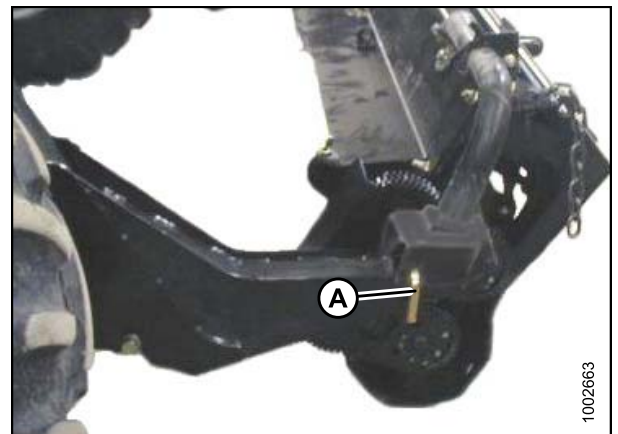

Figure 3.30: Windrower Arms

UNLOADING AND ASSEMBLY

10. Remove the stand (A) and store with hairpin (B) in toolbox.
11. Lift the conditioner and position into the header opening from the rear.

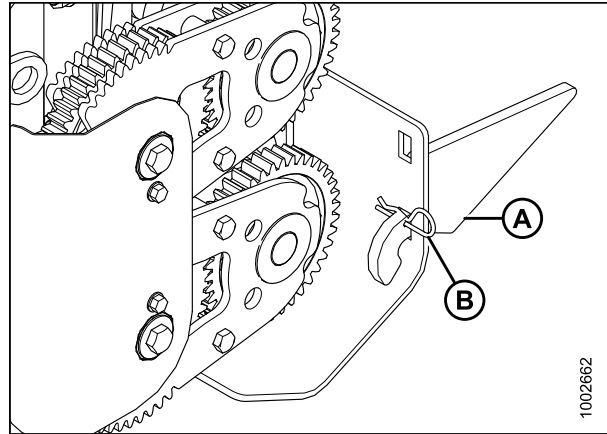

Figure 3.31: Conditioner Stand

12. Carefully lower the windrower lift legs until lugs (A) on conditioner are seated in the U-shaped brackets (B) on header.
13. Ensure the conditioner is seated properly in the brackets before you disconnect from windrower.

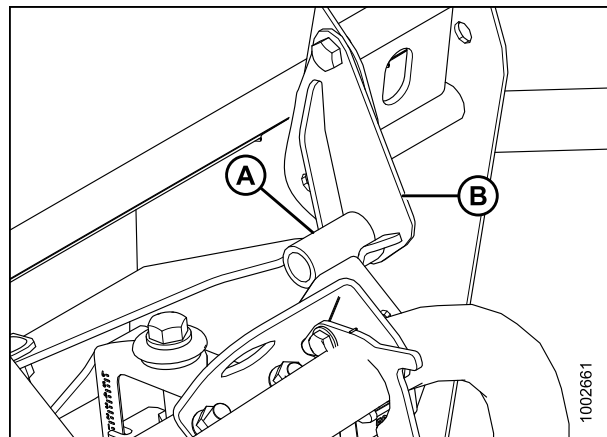

Figure 3.32: Conditioner Lug

14. Lift latch (B) to release conditioner lift arm (A) and fold up to storage position on conditioner.

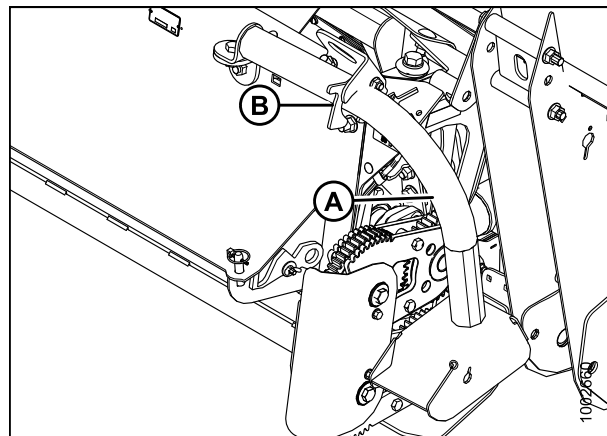

Figure 3.33: Conditioner Lift Arm

UNLOADING AND ASSEMBLY

15. Install L-pin (A) through arm and bracket on conditioner and lock into place. (Rotate pins to align key-hole slot). Repeat for other arm.

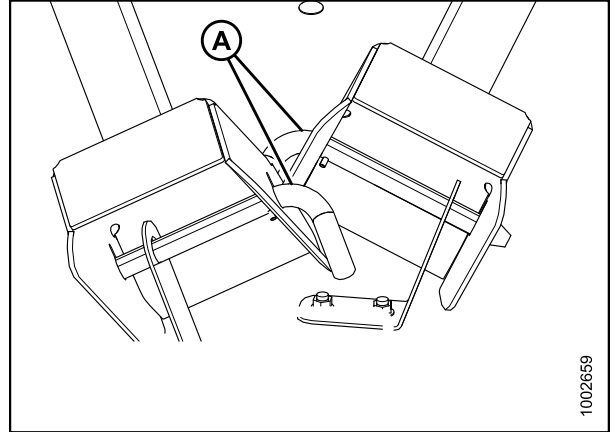

Figure 3.34: L-Pins on Header Arm

16. Install 5/8 in. x 1-1/2 in. carriage bolt (A) in the right-hand lower attachment location.

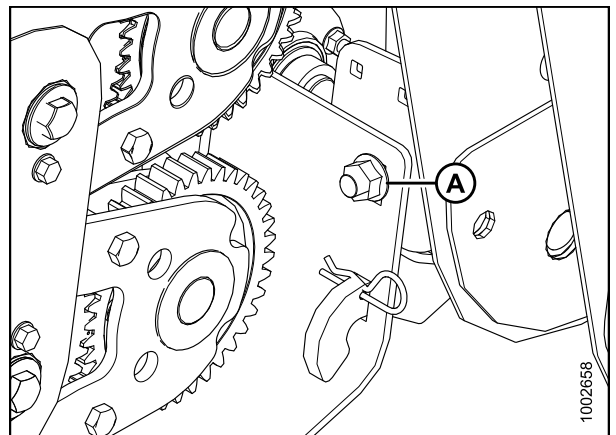

Figure 3.35: Conditioner – RH Side

17. Install 5/8 in. x 1-1/2 in. carriage bolt (A) in the left-hand lower attachment location.

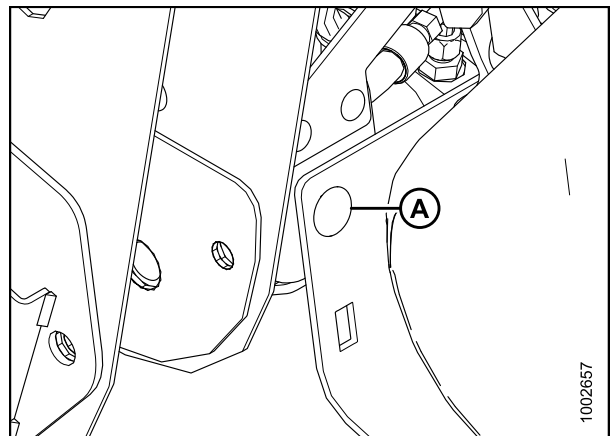

Figure 3.36: Conditioner – LH Side

UNLOADING AND ASSEMBLY

18. Connect the five hydraulic hoses between the conditioner and the header as follows:
- Small male quick-disconnect from motor to header (A)
 - Large female quick-disconnect from motor to header (B)
 - Small female quick-disconnect from deck to header (C)
 - Small female quick-disconnect from motor to deck (D)
 - Large female quick-disconnect from header to motor (E)

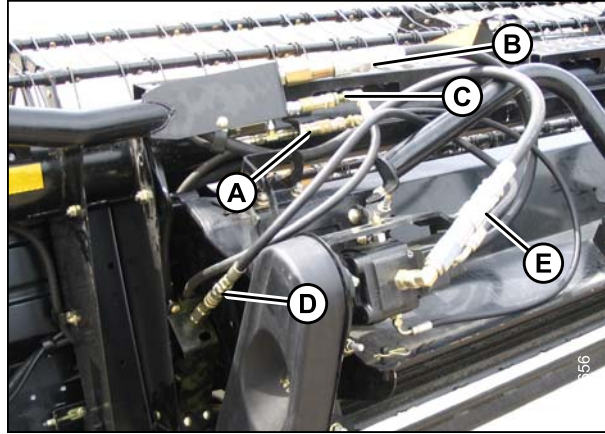

Figure 3.37: Hydraulic Hoses

A - Case Drain
B - Conditioner Motor Pressure
C - Deck Motor Return
D - Deck Motor Pressure
E - Conditioner Motor Return

3.7 Attaching Hydraulics

The procedure for attaching hydraulics is different for 15-foot draper headers.

- If attaching a 15-foot header, refer to [3.7.1 Attaching Hydraulics: 15-Foot Headers, page 45](#).
- When attaching any other size header, refer to [3.7.2 Attaching Hydraulics: All Headers Except 15-Foot, page 47](#).

3.7.1 Attaching Hydraulics: 15-Foot Headers

To attach hydraulics to a 15-foot draper header, follow these steps:

1. Disconnect return hose (A) at elbow on motor.
2. Install check valve tee (A) on elbow and reconnect return hose (B) to tee (A).
3. Connect feed draper return line (C) from the conditioner hose package onto the check valve.

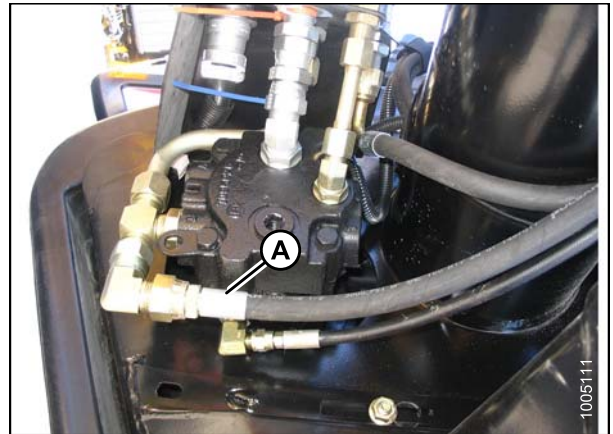

Figure 3.38: Return Hose

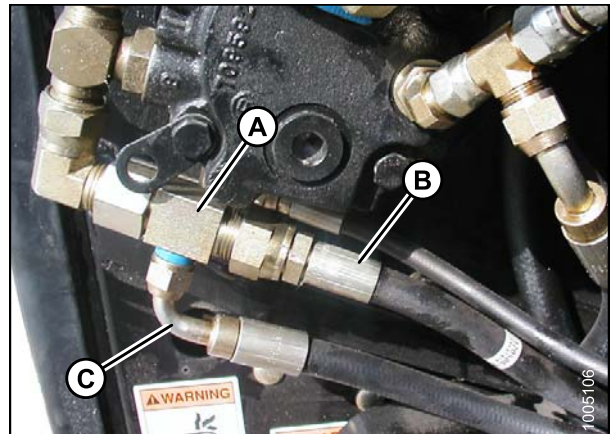

Figure 3.39: Check Valve and Hoses

UNLOADING AND ASSEMBLY

4. Remove the knife drive coupler (A), draper drive coupler (B), the case drain coupler (C) and its extension tube (D).

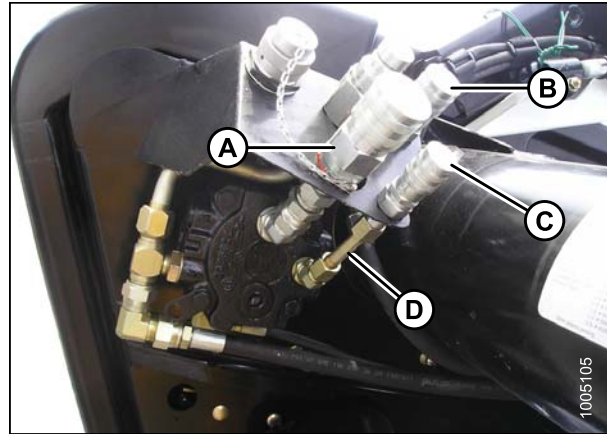

Figure 3.40: Hydraulic Couplers

5. Retrieve coupler bracket (A) from bundle and position the coupler bracket (A) onto housing.
6. Reinstall the draper drive coupler (B) in original location and install the knife drive coupler (C) onto the end of the new bracket (A).

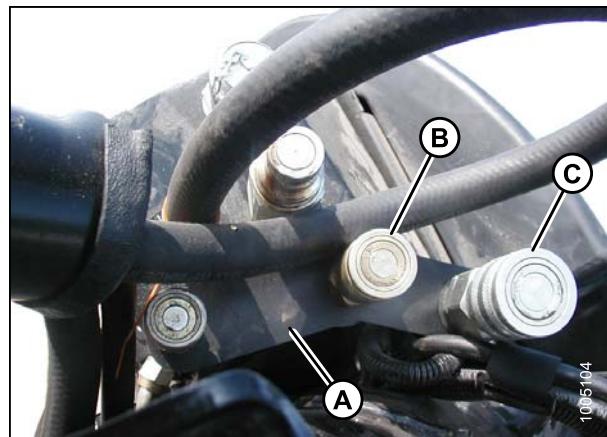

Figure 3.41: Hydraulic Couplers

7. Install the tee fitting (A) and union (B) onto motor case drain.
8. Reinstall the case drain coupler (C).
9. Route the conditioner case drain hose (D) (45° bent tube) behind the motor and connect to the tee fitting (A).

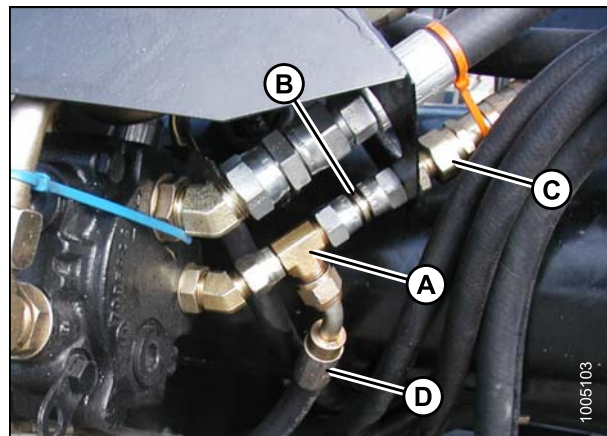

Figure 3.42: Case Drain Hydraulics

UNLOADING AND ASSEMBLY

10. Route the conditioner pressure hose (A) (orange cable tie) behind the motor and attach it to the coupler (B).

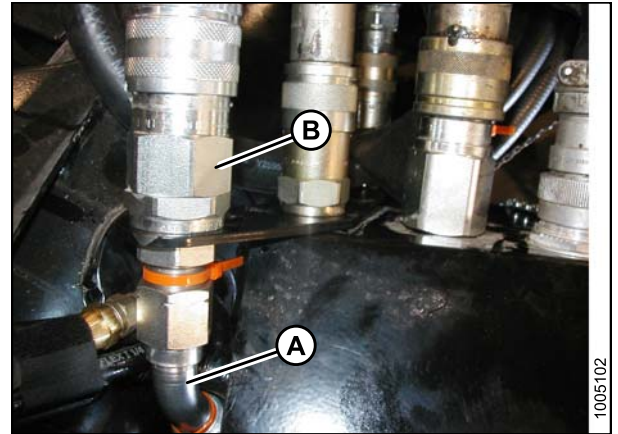

Figure 3.43: Conditioner Hydraulics

11. Loop the conditioner return line (A) up over top of the couplers and connect to the pressure port (B) on the motor. Ensure all hoses will be clear of windrower tires.

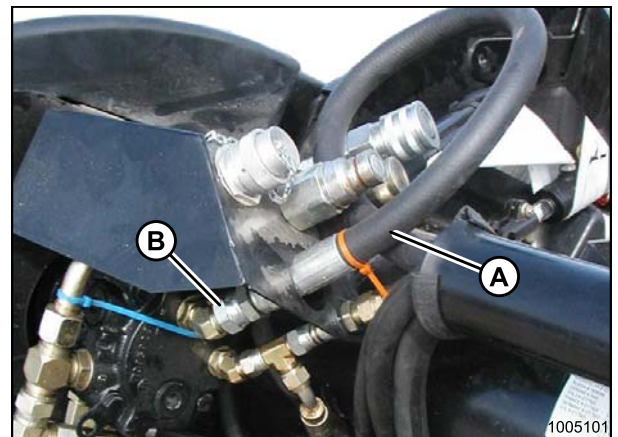

Figure 3.44: Conditioner Hydraulics

3.7.2 Attaching Hydraulics: All Headers Except 15-Foot

To attach hydraulics to all headers (not including 15-foot), follow these steps:

1. Identify the hydraulic coupler components shown in Figure 3.45: *Hydraulic Coupler Components*, page 47.
2. Remove hose cover (A) from left-hand coupler mount.
3. Disconnect the side draper return hose (C) at the main return tee (refer to item [E] in Figure 3.45: *Hydraulic Coupler Components*, page 47).

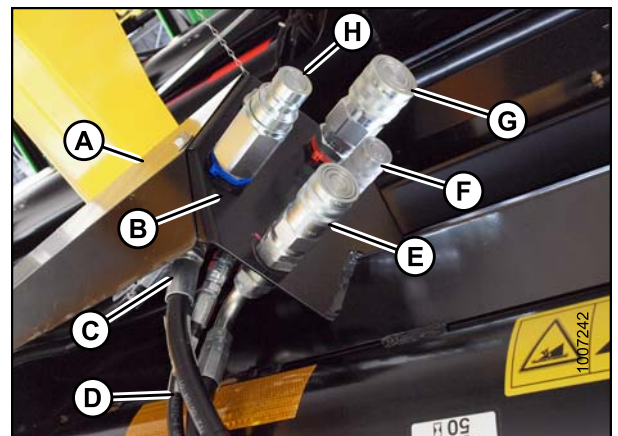

Figure 3.45: Hydraulic Coupler Components

A - Hose Cover
B - Coupler Mount
C - Side Draper Return
D - LH Draper Case Drain
E - To Side Drapers (Pressure)
F - Case Drain Coupler
G - Knife/Conditioner Pressure
H - Header Return

UNLOADING AND ASSEMBLY

4. Detach knife motor case drain line (D) from bulk head fitting at coupler mount (A).
5. Install conditioner case tee fitting (B) and conditioner case drain line (C).
6. Remove knife drive hose (G).

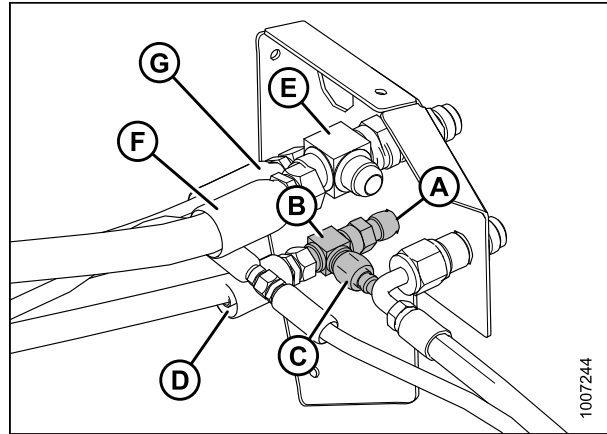

Figure 3.46: Hydraulic Coupler Components

A - Coupler Mount	B - Conditioner Case Tee
C - Conditioner Case Drain	D - Knife Motor Case Return
E - Header Return Tee	F - Knife Return
G - Knife Drive Hose	

7. Install check valve tee (A) on the main return tee (E).

NOTE:

Arrow on check valve tee fitting should face up.

8. Install the feed draper return hose (C) with the blue tie to the check valve tee (A).
9. Reinstall the side draper return hose (B) that was removed in step 3., page 47, to the new check valve tee (A).
10. Connect conditioner return hose (D) with union to Knife drive hose (F) removed in step 6., page 48.
11. Attach Conditioner drive hose (G) with orange tie to the coupler where knife drive hose was removed in step 6., page 48.
12. Bundle the hoses with cable ties as required. Ensure hoses do **NOT** contact sharp edges.
13. Replace hose cover.

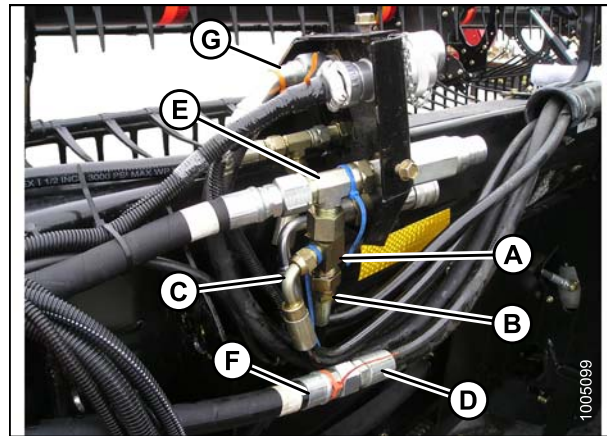

Figure 3.47: Hydraulic Coupler Components

A - Check Valve Tee	B - Side Draper Motor Return
C - Feed Draper Return	D - Conditioner Return
E - Header Return Tee	F - Knife Drive Hose
G - Conditioner Drive	

UNLOADING AND ASSEMBLY

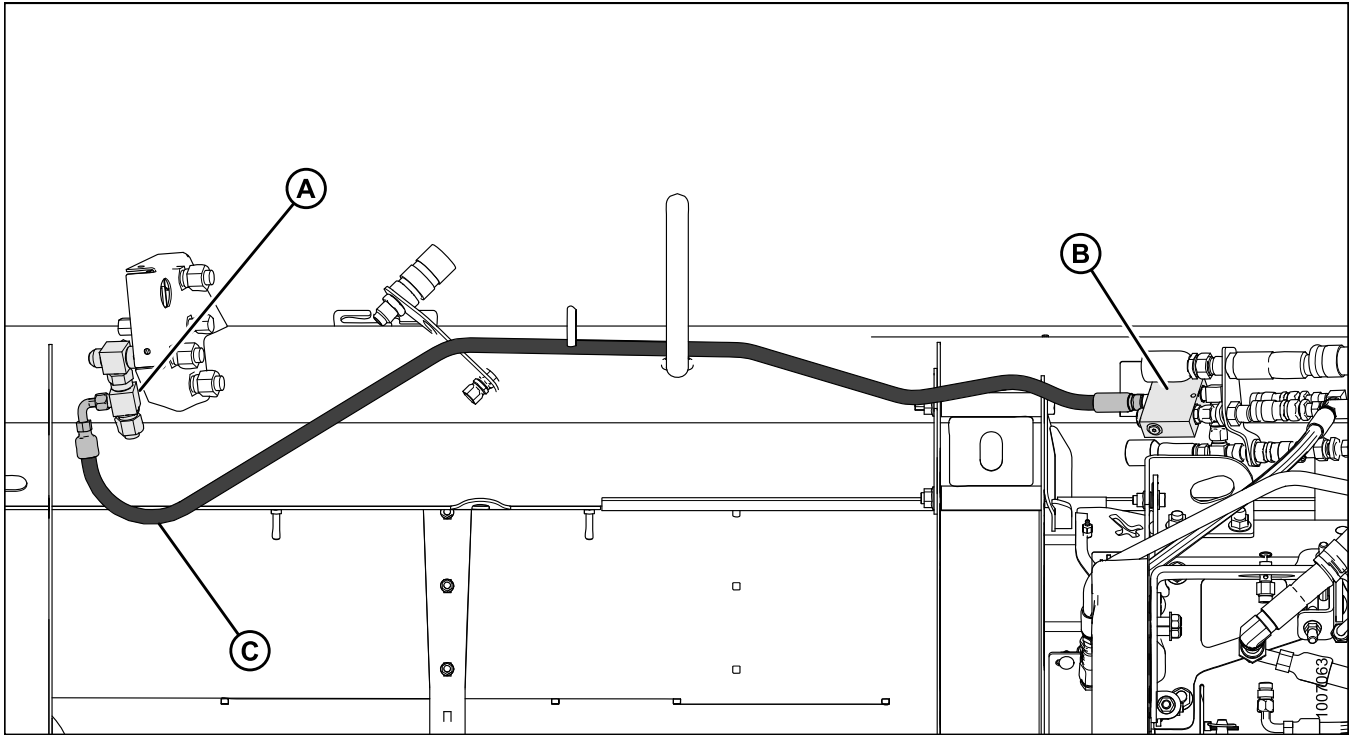

Figure 3.48: Feed Draper Return Hydraulics

Shields removed to expose the feed draper return hose connection

A - Check Valve Tee

B - Pressure Reducing Valve

C - Feed Draper Return Hose

3.8 Header Schematics

If you require help with acronyms used in this section, refer to [2.1 Definitions, page 9](#) for clarification.

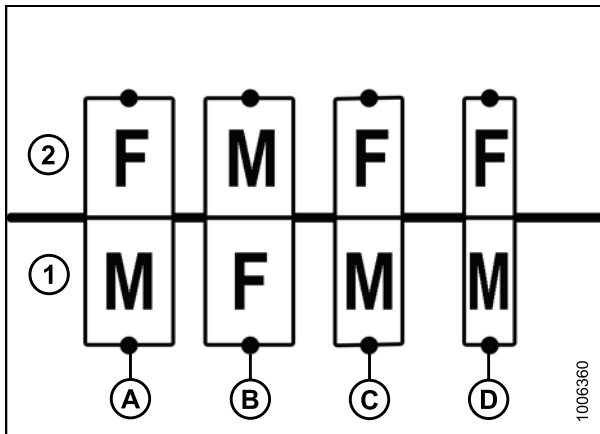

Figure 3.49: Coupler Legend When Connected to a Windrower

A - Knife Drive Pressure (3/4 in. Coupler) B - Draper/Knife Return Line (3/4 in. Coupler) C - Draper Pressure (1/2 in. Coupler)
 D - DKD Header Case Return Only (3/8 in. Coupler)

NOTE:

Callout 1 is the windrower coupler side, callout 2 is the header coupler side

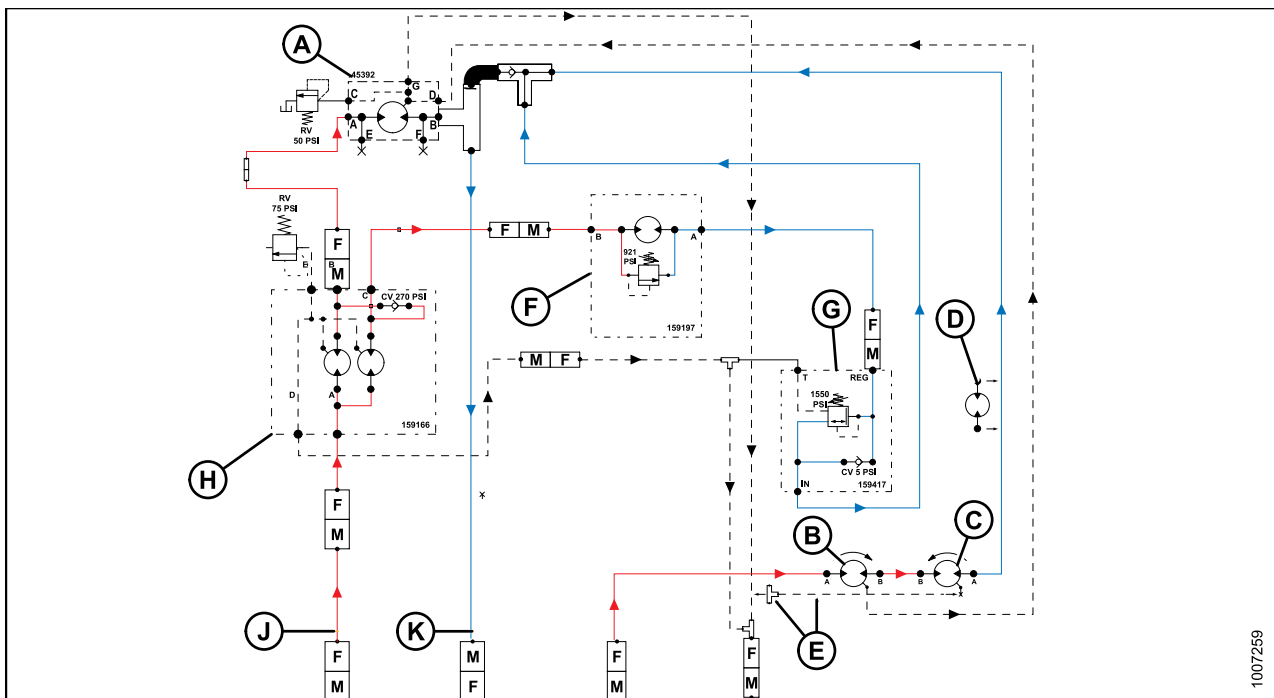
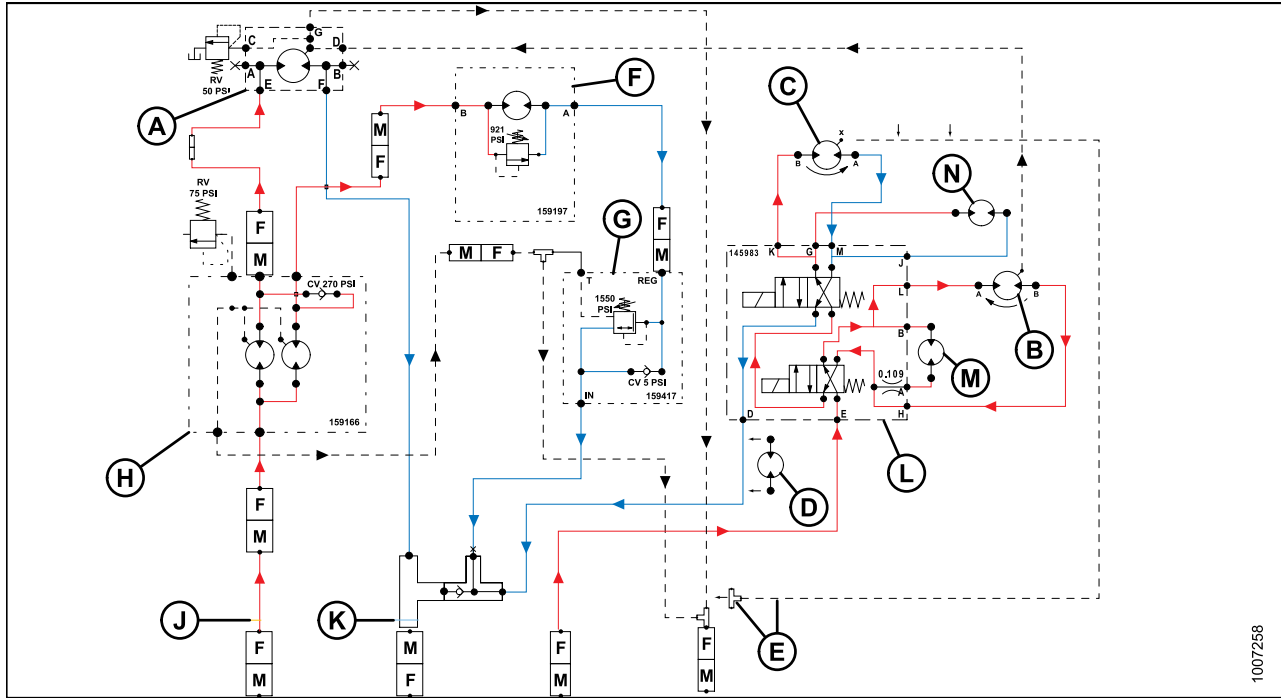

Figure 3.50: D-Series 15-ft. DKD timed, HDS, HC10

A - Timed Knife Drive Motor B - LH Draper Motor (Inboard) C - RH Draper Motor (Inboard)
 D - Upper Cross Auger Motor (Option) E - Case Drain Kit (MD #B5842)
 G - Pressure Reducing Valve H - Hay Conditioner Motor
 J - Orange Tie
 K - Blue Tie

UNLOADING AND ASSEMBLY



1007258

Figure 3.51: D-Series DKD timed, HDS, HC10, UCA (All headers except 15-ft.)

- | | | |
|--|--------------------------------|-------------------------------|
| A - Timed Knife Drive Motor | B - LH Draper Motor (Inboard) | C - RH Draper Motor (Inboard) |
| D - Upper Cross Auger Motor (Option) Plumb at Port D | E - Case Drain Kit (MD #B5842) | F - Feed Deck Motor |
| G - Pressure Reducing Valve | H - Hay Conditioner Motor | J - Orange Tie |
| K - Blue Tie | L - Deck Shift Valve | M - LH Deck Shift Motor |
| N - RH Deck Shift Motor | | |

3.9 Assembling the Forming Shield

To assemble forming shield, follow these steps:

1. Unpack the forming shield cover (A) and deflectors and fins bundle (B).

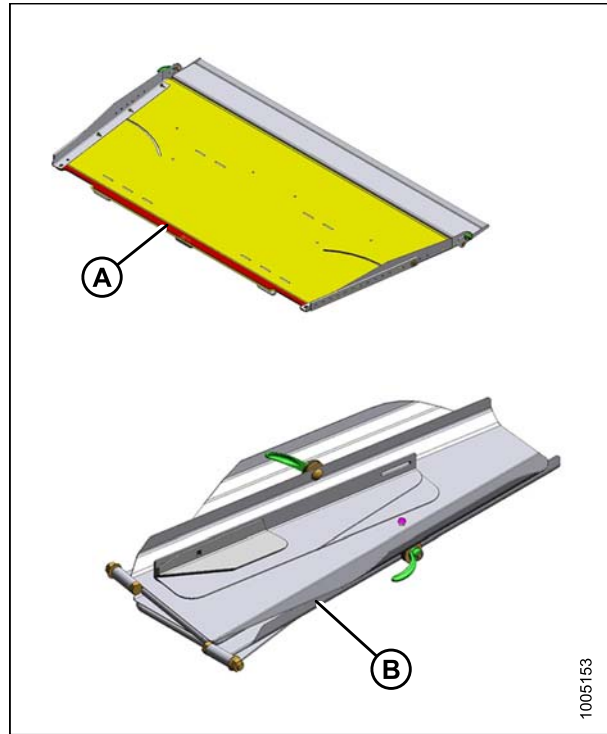

Figure 3.52: Forming Shield Components

2. Lay cover (A) upside down (flanges of side supports facing up) on a flat surface.

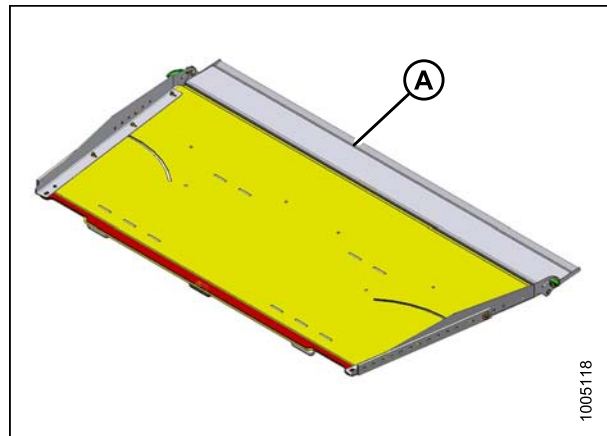

Figure 3.53: Forming Shield Cover

UNLOADING AND ASSEMBLY

3. Assemble fins (A) to bottom of shield as shown in Figure 3.54: *Deflector Fins*, page 53 using hardware provided. The two long fins (B) are handed (outboard and inboard sides) and should be installed with bolts on outboard side of the fin. Bolts should be installed with nuts against the fins.

NOTE:

Fins are only effective for windrows greater than 70 in. (1778 mm) or if satisfactory formation is not achieved. Store for future use if not installed.

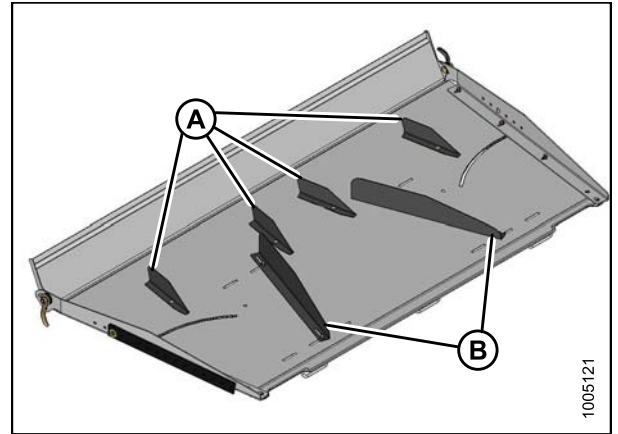

Figure 3.54: Deflector Fins

4. Position fins approximately as shown in Figure 3.55: *Deflector Fins*, page 53, and tighten hardware.

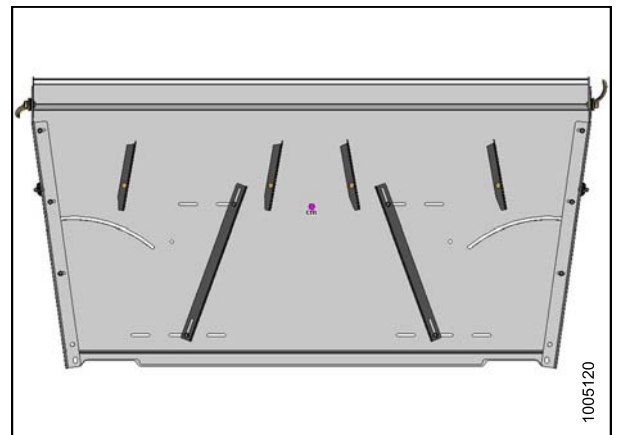

Figure 3.55: Deflector Fins

5. Remove hardware (A) from side deflectors (B).

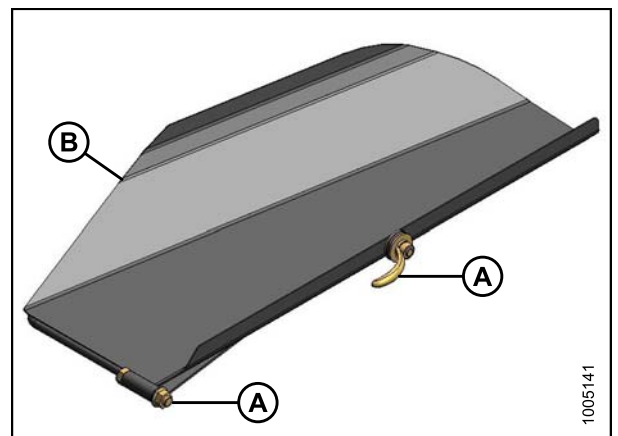

Figure 3.56: Side Deflector

UNLOADING AND ASSEMBLY

6. Position deflector (A) on cover as shown in Figure 3.57: *Side Deflector – LH, page 54* and install with hex bolt (B) and flange nut removed in previous step.
7. Tighten flange nut enough to hold deflector (A) in position, but still allow deflector to move.

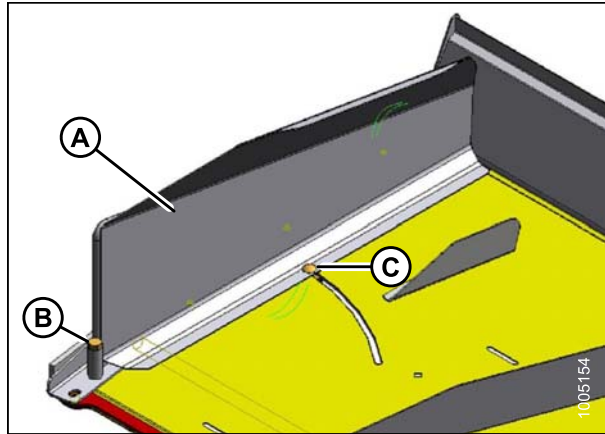

Figure 3.57: Side Deflector – LH

A - Side Deflector B - Hex Bolt
C - Bolt (referred to in next step)

8. Install bolt, washers, and handle nut (A) as shown in Figure 3.58: *Handle – LH, page 54*. Rubber washer (B) must be positioned between metal washers (C).
9. Tighten handle nut (A) against cover to lock deflector in desired position.
10. Repeat for the other deflector.

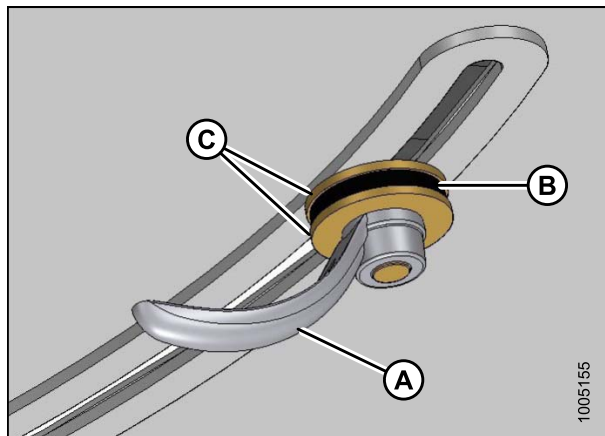

Figure 3.58: Handle – LH

11. Invert forming shield to installation position as shown in Figure 3.59: *Forming Shield, page 54*.

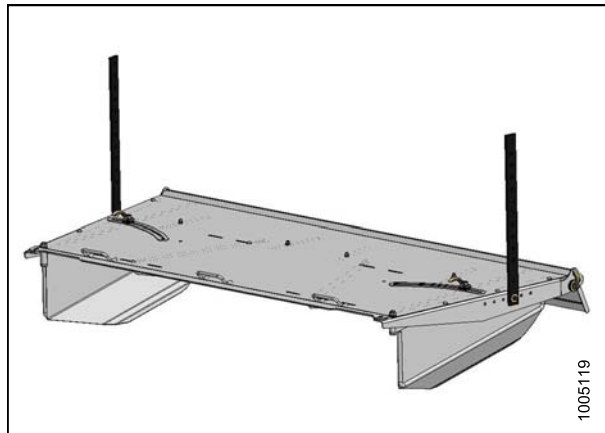

Figure 3.59: Forming Shield

3.10 Installing the Forming Shield

To install the forming shield, follow these steps:

1. Position the forward end of the forming shield (A) onto the two pins (B) located on the rear cover of the conditioner.

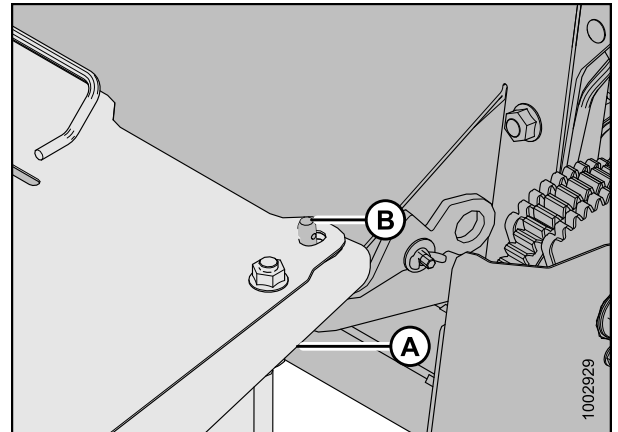

Figure 3.60: Forming Shield

2. Insert lynch pins (A) to secure forming shield to conditioner.

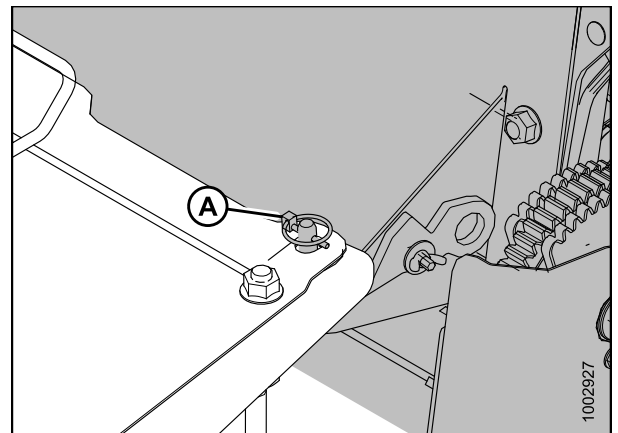

Figure 3.61: Lynch Pin

3. Set forming shield side deflectors to desired width by loosening handle (A) and moving deflector (B). Set both deflectors to approximately the same position.
4. Tighten handles (A).
5. Loosen handles (C) and adjust fluffer shield (D) to middle position.
6. Tighten handles (C).

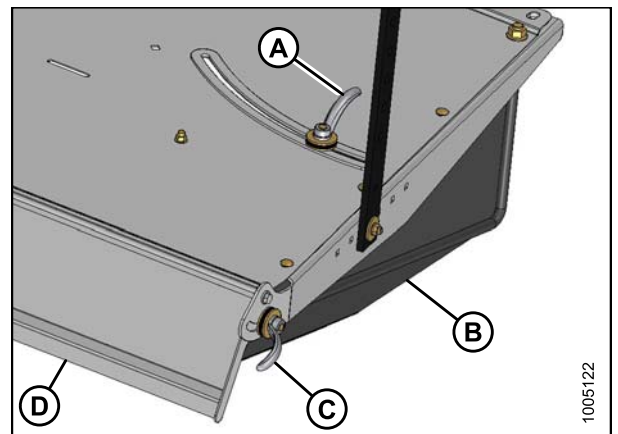

Figure 3.62: Forming Shield

UNLOADING AND ASSEMBLY

7. Install shield transport support (A) on windrower frame with two 3/8 x 1.0 in. carriage bolts and nuts (B).

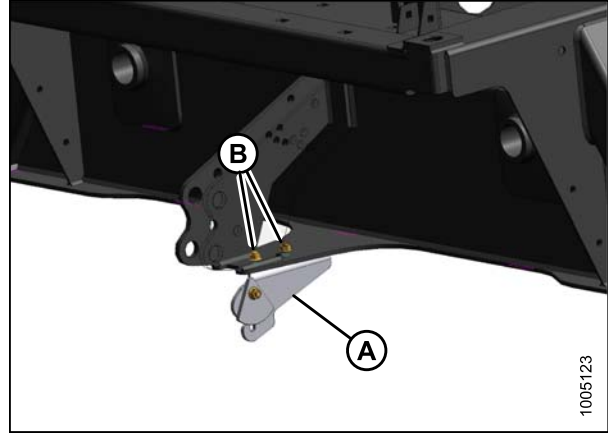

Figure 3.63: Shield Transport Support

3.11 Attaching to a Windrower

Refer to the windrower unloading and assembly instructions or operator's manual for instructions on attaching the header to an M-Series Self-Propelled Windrower.

Once the header and windrower are attached, follow these steps:

1. Lift the aft end of the forming shield and attach straps (B) to pins (A) on windrower frame.
2. Retrieve washers and hairpins from shipping bundle and install to secure strap. Use the middle hole and adjust height to suit the crop.

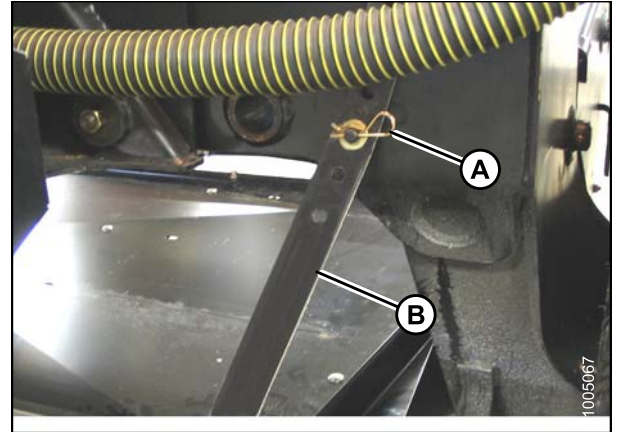

Figure 3.64: Rubber Strap

3.12 Lubricating the Conditioner

3.12.1 Greasing Procedure

CAUTION

To avoid personal injury, before servicing header or opening drive covers, follow procedures in [5.1 Preparation for Servicing, page 89](#).

1. To avoid injecting dirt and grit, wipe grease fitting with a clean cloth before greasing. For various locations of grease fittings, refer to [3.12.2 Lubrication Points, page 59](#).
2. Inject grease through fitting with grease gun until grease overflows fitting, except where noted. For detailed lubrication information, refer to [5.4 Lubrication, page 92](#).
3. Leave excess grease on fitting to keep out dirt.
4. Replace any loose or broken fittings immediately.
5. If fitting will not take grease, remove and clean thoroughly. Also clean lubricant passageway. Replace fitting if necessary.

3.12.2 Lubrication Points

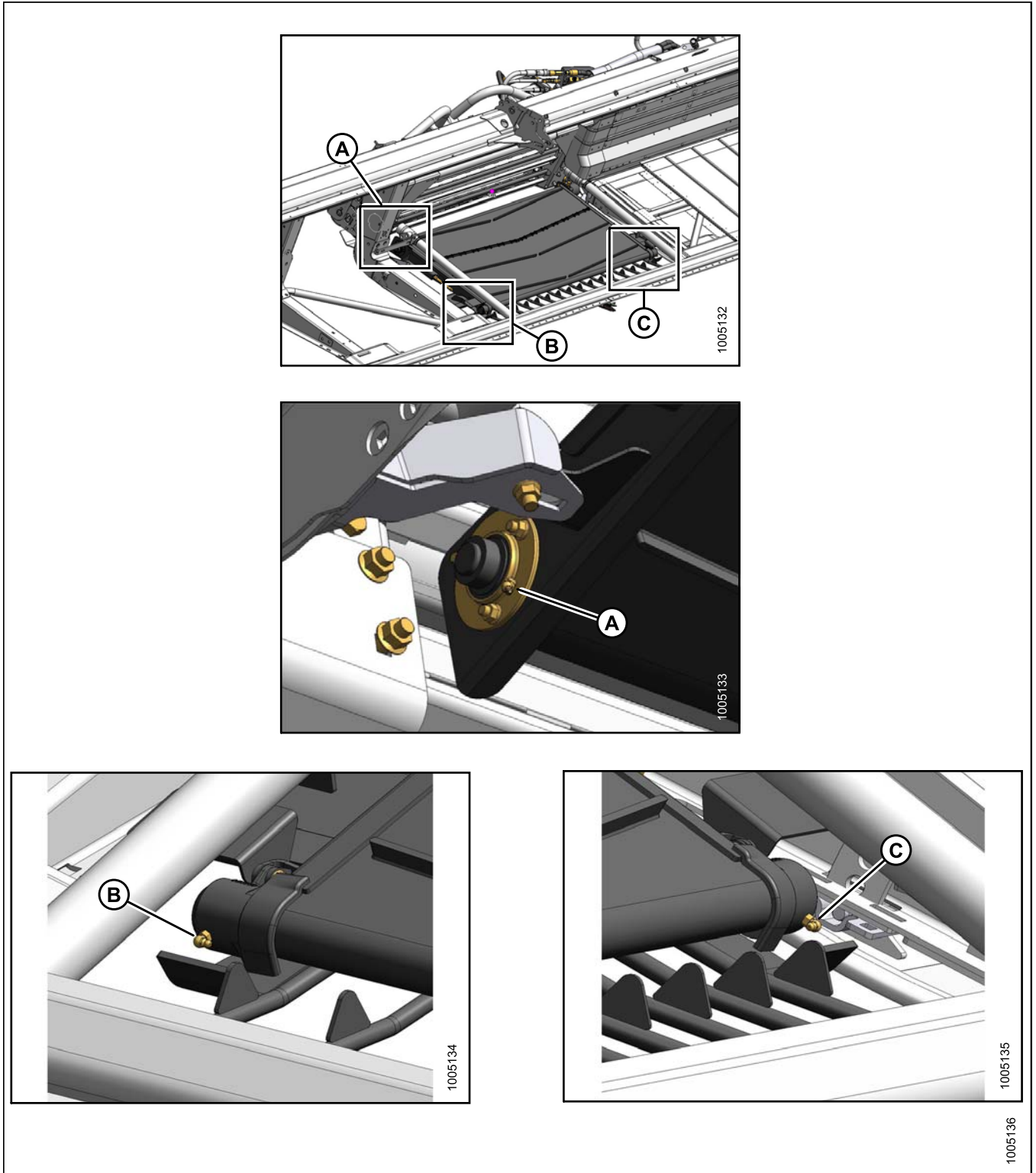

Figure 3.65: Lubrication Points

A - Drive Roller Bearing Lubrication Point

B - Idler Roller Bearing Lubrication Point

C - Idler Roller Bearing Lubrication Point

UNLOADING AND ASSEMBLY

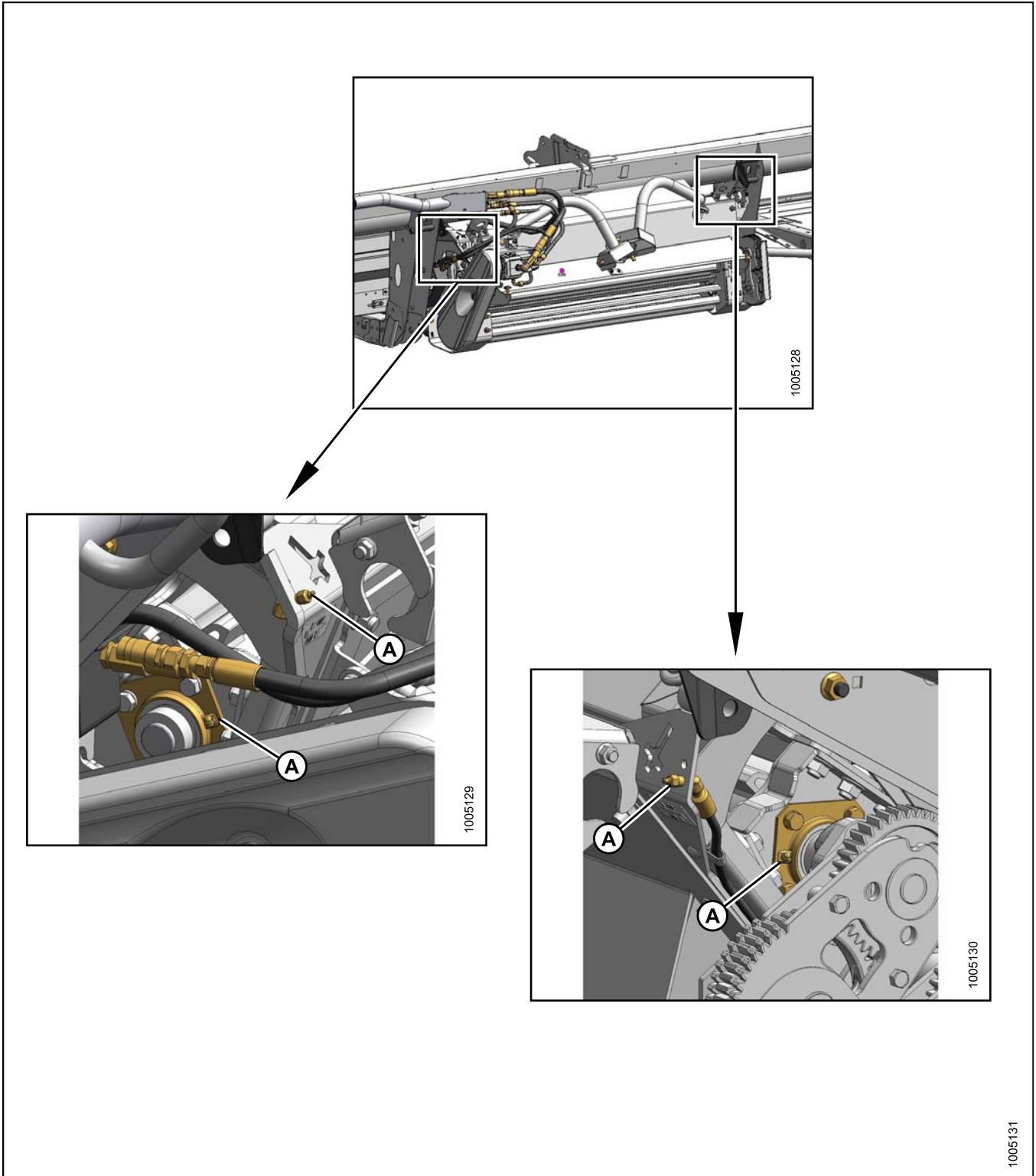

Figure 3.66: Lubrication Points
A - Roll Shaft Bearing Lubrication Points (Four Places)

3.13 Performing Predelivery Checks

WARNING

Stop engine and remove key before making adjustments to machine. A child or even a pet could engage the drive.

Perform the final checks and adjustments as listed on the **Predelivery Checklist** (yellow sheet attached to this instruction – refer to [Model HC10 Hay Conditioner Predelivery Checklist, page 141](#)) along with the header final checks and adjustments to ensure the machine is field-ready. Refer to the following pages for detailed instructions as indicated on the checklist.

The completed checklist should be retained either by the Operator or the Dealer.

3.13.1 Checking Roll Drive Belt Tension

To check the roll drive belt tension, follow these steps:

1. Remove wing nut and washer (A) and remove drive cover (B).
2. Apply force to deflect belt. Belt should deflect 1/4 inch (7 mm) when a force of 8–16 lbf (36–72 N) is applied at the center of the span. If belt tension requires adjusting, refer to [5.7.1 Adjusting Drive Belt Tension, page 96](#).
3. Replace cover and secure with washer and wing nut.

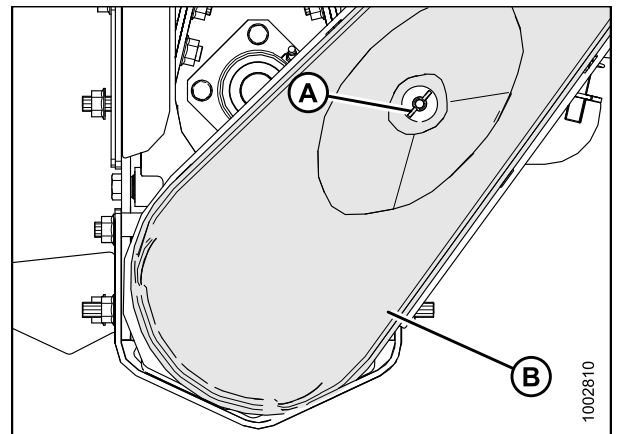

Figure 3.67: Drive Cover

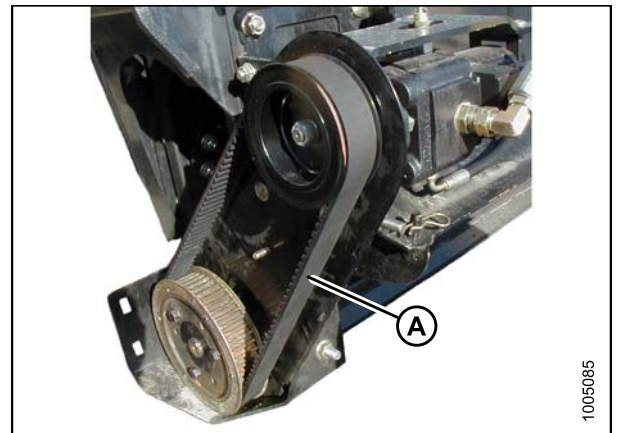

Figure 3.68: Drive Belt

3.13.2 Checking Roll Gap

Factory setting should be 3/4 in. (20 mm) or at 1.5 line on gauge (A). Gauge readings should be the same at both ends of the roll. If roll gap requires adjusting, refer to [4.9.2 Adjusting Roll Gap, page 82](#).

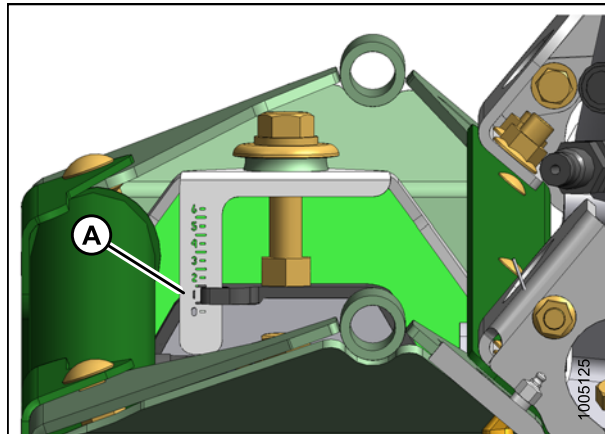

Figure 3.69: Roll Gap Gauge

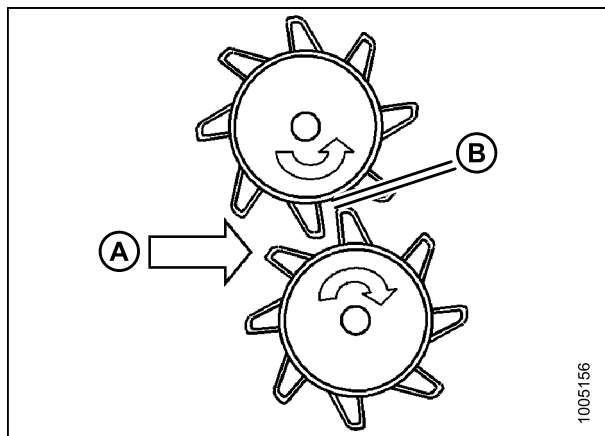

Figure 3.70: Roll Gap

A - Crop direction

B - Roll gap

3.13.3 Checking Roll Timing

CAUTION

Stop engine and remove key from ignition before leaving Operator's seat for any reason. A child or even a pet could engage an idling machine.

To check the roll timing, follow these steps:

1. Lower header to ground, shut down windrower, and remove key.
2. Remove wing nut and remove tool from panel at right-hand end of conditioner.

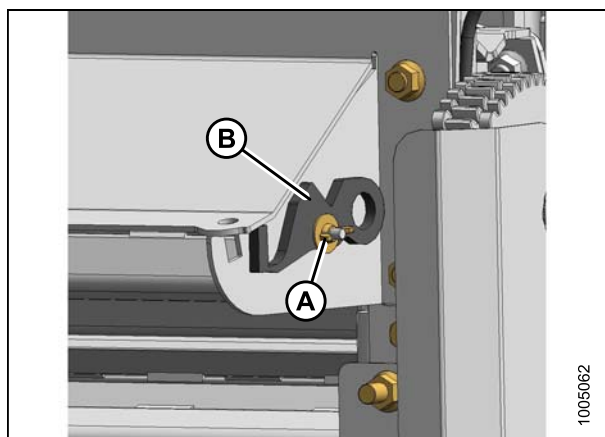

Figure 3.71: Conditioner End – RH

UNLOADING AND ASSEMBLY

3. From the rear of the conditioner, locate tool at center of rolls as shown (A) and manually turn rolls to limits of tool. Rolls will engage the tool if timing is correct.
4. Manually turn rolls to release tool.

WARNING

Remove tool from rolls and return it to storage location before starting machine.

5. Replace tool on conditioner with washer and wing nut.
6. If roll timing requires adjusting, refer to [4.9.3 Checking and Adjusting Roll Timing, page 83](#).



Figure 3.72: Roll Timing Tool

A - Start position

B - Gauge position

3.13.4 Running Up the Conditioner

CAUTION

Never start or move the machine until you are sure all bystanders have cleared the area.

CAUTION

Clear the area of other persons, pets etc. Keep children away from machinery. Walk around the machine to be sure no one is under, on, or close to it.

CAUTION

Before investigating an unusual sound or attempting to correct a problem, shut off engine, engage parking brake, and remove key.

Refer to the windrower unloading and assembly instructions or operator's manual for windrower operating instructions.

To run up the conditioner, follow these steps:

1. Start windrower and run the machine. Operate the conditioner slowly for 5 minutes, watching and listening FROM THE OPERATOR'S SEAT for binding or interfering parts.
2. Run machine for 15 minutes.
3. Perform the run-up check as listed on the Predelivery Checklist (yellow sheet attached to this instruction – refer to [Model HC10 Hay Conditioner Predelivery Checklist, page 141](#)) and the header run-up check to ensure the machine is field-ready.

3.13.5 Storing Manuals

Place this manual (MD #169254) in the storage case (A) in the windrower. The Predelivery Checklist (yellow sheet attached to this instruction – refer to [Model HC10 Hay Conditioner Predelivery Checklist, page 141](#)) should be retained by either the Dealer or the Operator.

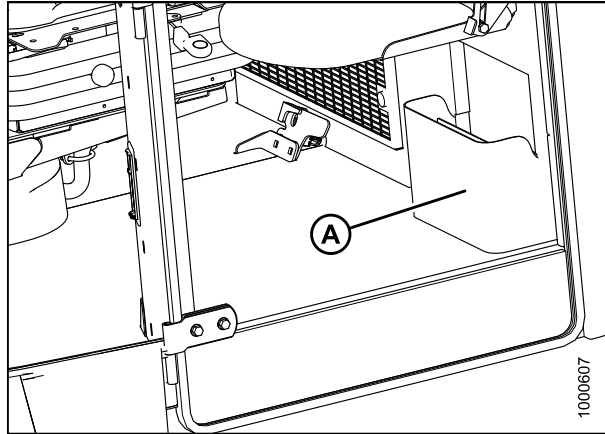

Figure 3.73: Manual Storage Case (M155 Shown)

4 Operation

4.1 Owner/Operator Responsibilities

CAUTION

- It is your responsibility to read and understand this manual completely before operating the header. Contact your MacDon Dealer if an instruction is not clear to you.
- Follow all safety messages in the manual and on safety decals on the machine.
- Remember that YOU are the key to safety. Good safety practices protect you and the people around you.
- Before allowing anyone to operate the header, for however short a time or distance, make sure they have been instructed in its safe and proper use.
- Review the manual and all safety related items with all Operators annually.
- Be alert for other Operators not using recommended procedures or not following safety precautions. Correct these mistakes immediately, before an accident occurs.
- Do NOT modify the machine. Unauthorized modifications may impair the function and/or safety and affect machine life.
- The safety information given in this manual does not replace safety codes, insurance needs, or laws governing your area. Be sure your machine meets the standards set by these regulations.

4.2 Operational Safety

CAUTION

Follow these safety precautions:

- Follow all safety and operational instructions given in your windrower operator's manuals. If you do not have a windrower manual, get one from your Dealer and read it thoroughly.
- Never start or move the machine until you are sure all bystanders have cleared the area.
- Stop engine and remove key before adjusting or removing plugged material from the machine. A child or even a pet could engage the drive.
- Check for excessive vibration and unusual noises. If there is any indication of trouble, shut down and inspect the machine. Follow proper shutdown procedure. Refer to [4.2.1 Shutting Down the Machine, page 66](#).
- Operate only in daylight or good artificial light.

4.2.1 Shutting Down the Machine

Before inspecting the machine, follow these steps to shut it off:

1. Return GSL to N-DETENT and center steering wheel to lock.
2. Disengage header drives.
3. Turn off engine and remove key.
4. Wait for all movement to stop.
5. Dismount and engage lift cylinder safety props on windrower lift legs before inspecting raised machine.

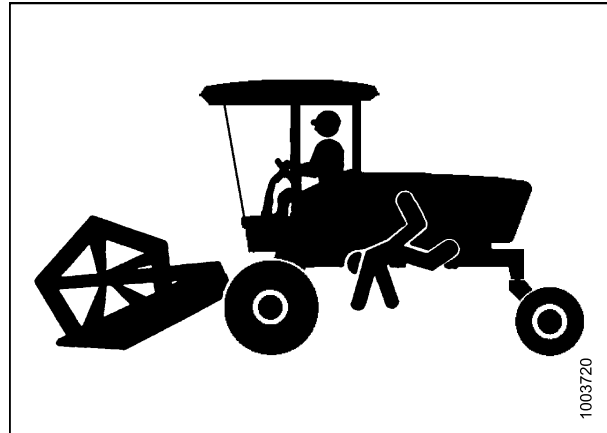

Figure 4.1: Safety Around Windrower

4.3 Attaching Hay Conditioner to Header

Refer to the following sections (in order) for instructions on installing the HC10 Hay Conditioner and forming shield on your D-Series draper header.

- [3.3 Installing the Rock Grate, page 32](#)
- [3.4 Installing Deck Brackets, page 33](#)
- [3.7 Attaching Hydraulics, page 45](#)
- [3.5 Installing the Feed Deck, page 35](#)
- [3.6 Installing the Conditioner, page 37](#)
- [3.9 Assembling the Forming Shield, page 52](#)
- [3.10 Installing the Forming Shield, page 55](#)

4.4 Detaching Hay Conditioner from Header

There are two methods for detaching the hay conditioner from the header:

- The windrower method
- The lifting method

4.4.1 Detaching Hay Conditioner: Windrower Method

CAUTION

To prevent accidental movement of windrower, return GSL to N-DETENT, center steering wheel to lock, shut off engine, and remove key.

To detach the hay conditioner from the header using the windrower method, follow these steps:

1. Disconnect straps (A) from windrower frame.
2. Lower header stand (A) to mid-position.
3. Detach header from windrower. Refer to windrower operator's manual for instructions.

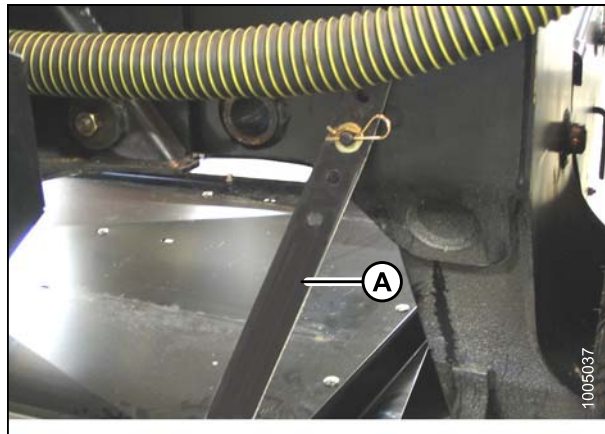

Figure 4.2: Rubber Strap



Figure 4.3: Header Stand

OPERATION

4. Remove the two lynch pins (A) securing forming shield to conditioner pins and remove shield.

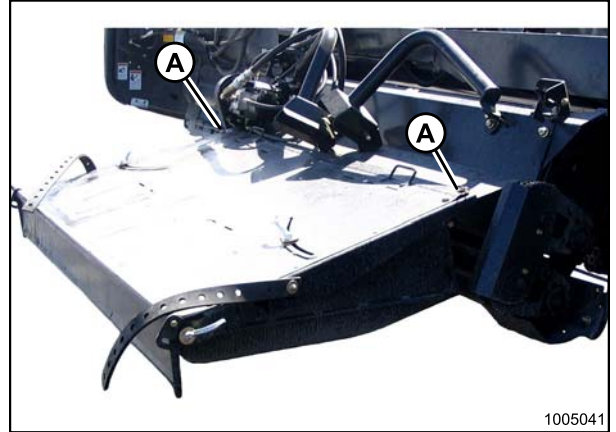

Figure 4.4: Forming Shield

5. Disconnect the five hydraulic hoses between the conditioner and the header.

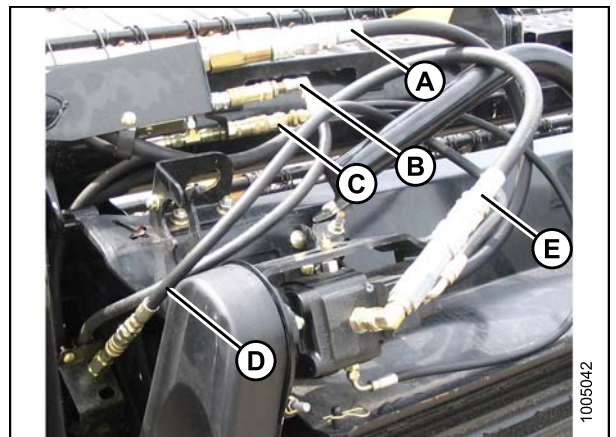

Figure 4.5: Hydraulic Hoses

A - Conditioner Motor Pressure Hose
B - Deck Motor Return Hose
C - Case Drain Hose
D - Deck Motor Pressure Hose
E - Conditioner Motor Return Hose

6. Remove the two carriage bolts (A) that attach conditioner to header.

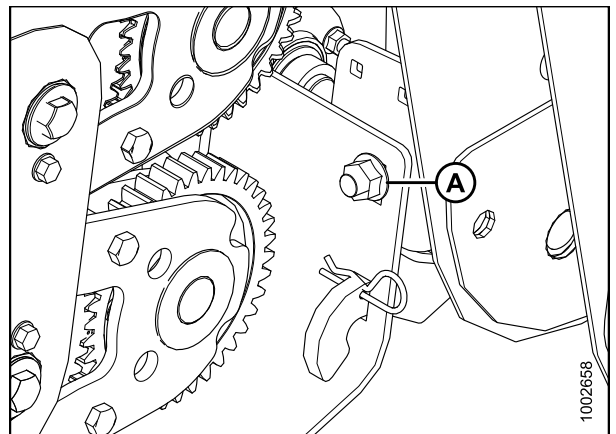

Figure 4.6: Conditioner – RH Side

OPERATION

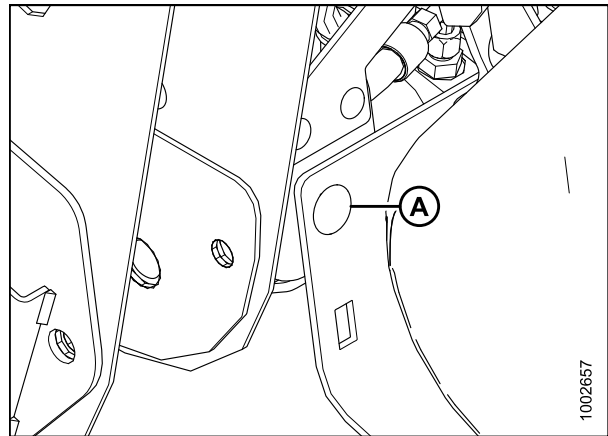

Figure 4.7: Conditioner – LH Side

7. Hardware at lifting arms has been tightened for shipping. If not done previously, loosen two bolts per side just enough to allow arms to swing out.
8. Remove L-pins (A) securing lifting arms to conditioner. (Rotate pins to align key-hole slot.)

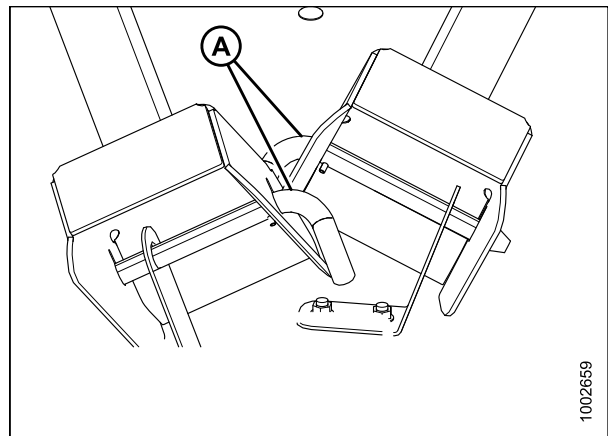

Figure 4.8: L-Pins on Header Arm

9. Swing out lift arms (A) and secure in latches (B).

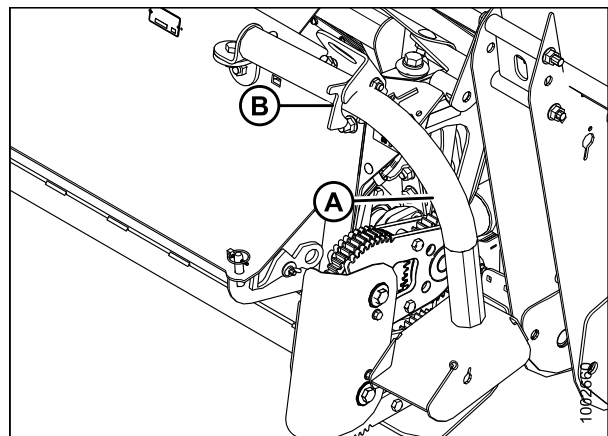

Figure 4.9: Conditioner Lift Arm

OPERATION

10. Position the windrower arms in the lift arm pockets (A) and insert the L-pins for safety.

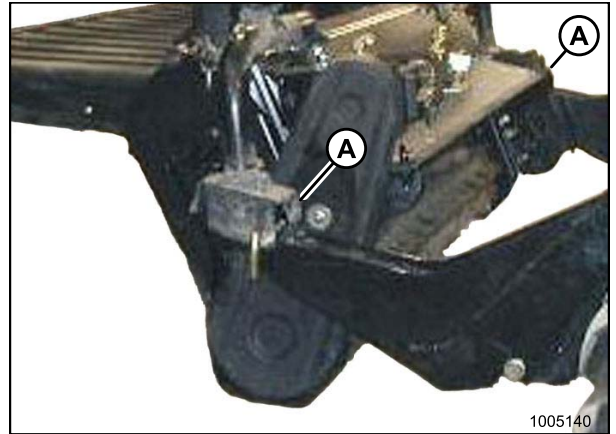

Figure 4.10: Lift Arm Pockets

11. Carefully raise the windrower lift legs until lugs (A) on conditioner clear the U-shaped brackets (B) on header.
12. Slowly back windrower away from header.

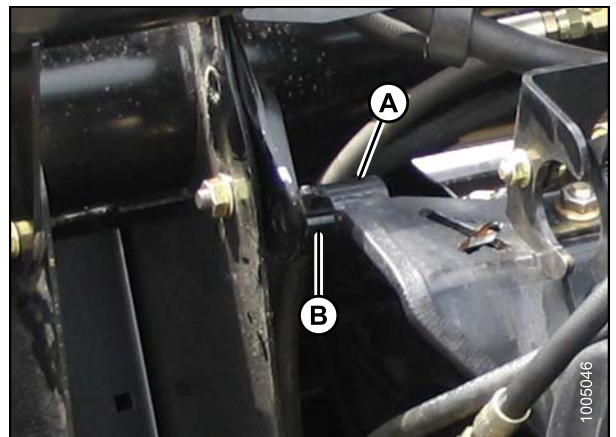

Figure 4.11: Conditioner Lug

13. Retrieve stand (A) from toolbox and install in slot at bottom of conditioner base. Secure with hairpin (B).
14. Lower conditioner to ground.

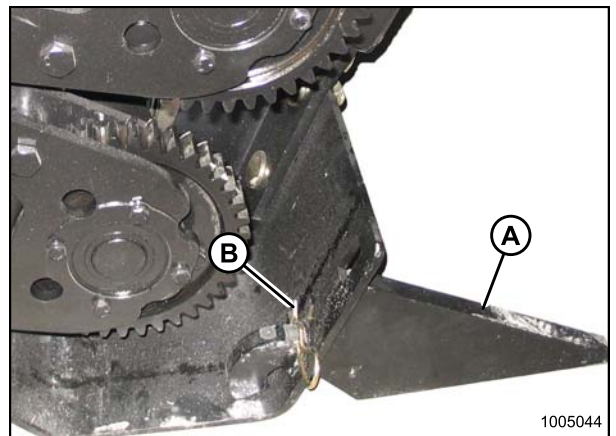

Figure 4.12: Conditioner Stand

OPERATION

15. Remove L-pins (A) from lift arms and back windrower away from conditioner.
16. Replace L-pins in conditioner lift arms.

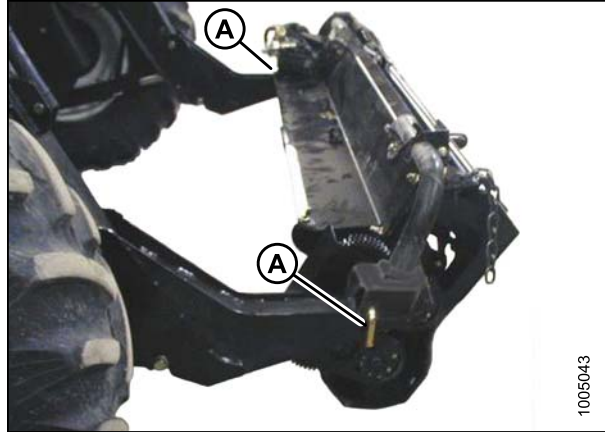

Figure 4.13: L-Pins

4.4.2 Detaching Hay Conditioner: Lifting Method

CAUTION

To prevent accidental movement of windrower, return GSL to N-DETENT, center steering wheel to lock, shut off engine, and remove key.

To detach the hay conditioner from the header using the lifting method, follow these steps:

1. Disconnect straps (A) from windrower frame.
2. Lower header stand (A) to mid-position.
3. Detach header from windrower. Refer to windrower operator's manual for instructions.

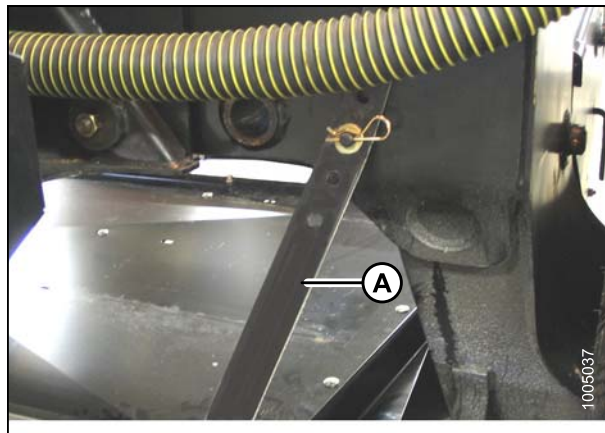

Figure 4.14: Rubber Strap

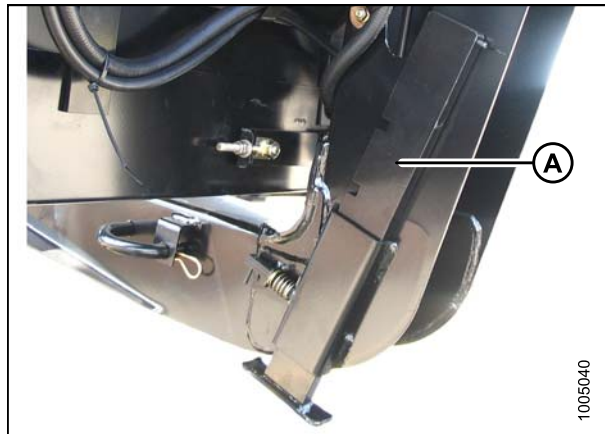

Figure 4.15: Header Stand

OPERATION

4. Remove the two lynch pins (A) securing forming shield to header pins and remove the forming

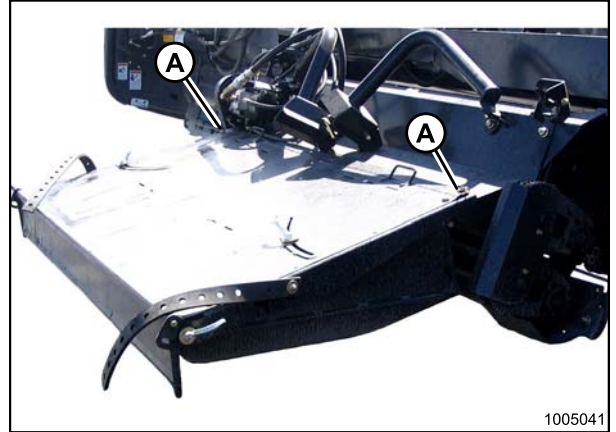

Figure 4.16: Forming Shield

5. Disconnect the five hydraulic hoses between the conditioner and the header.

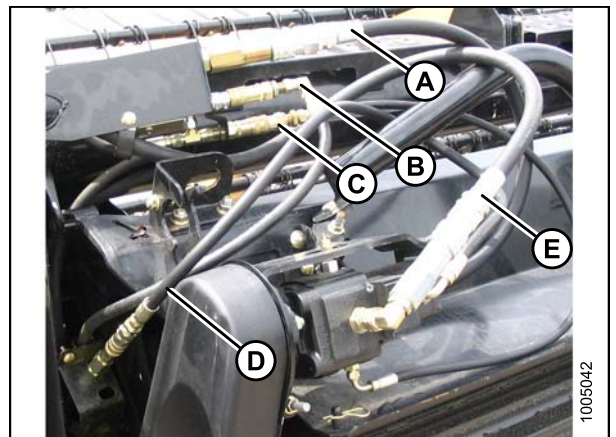

Figure 4.17: Hydraulic Hoses

A - Conditioner Motor Pressure Hose
B - Deck Motor Return Hose
C - Case Drain Hose
D - Deck Motor Pressure Hose
E - Conditioner Motor Return Hose

6. Remove the two carriage bolts (A) that attach conditioner to header.

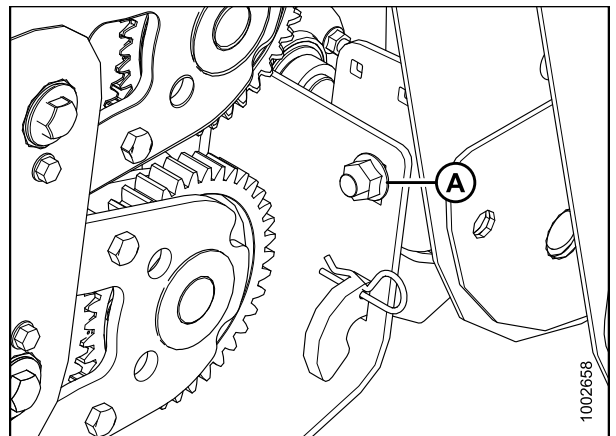

Figure 4.18: Conditioner – RH Side

OPERATION

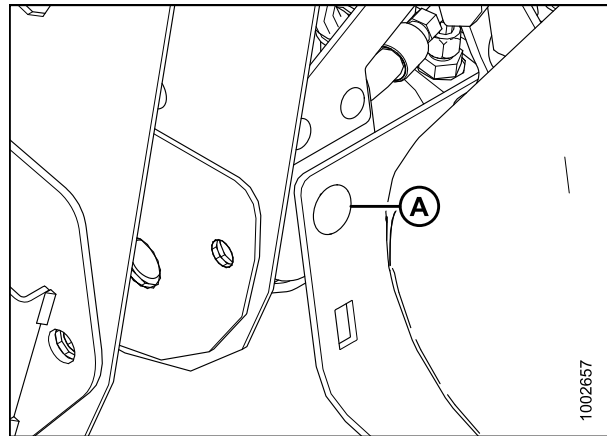

Figure 4.19: Conditioner – LH Side

7. Attach chain to lifting brackets (A) on conditioner and secure chain to lifting device (B).

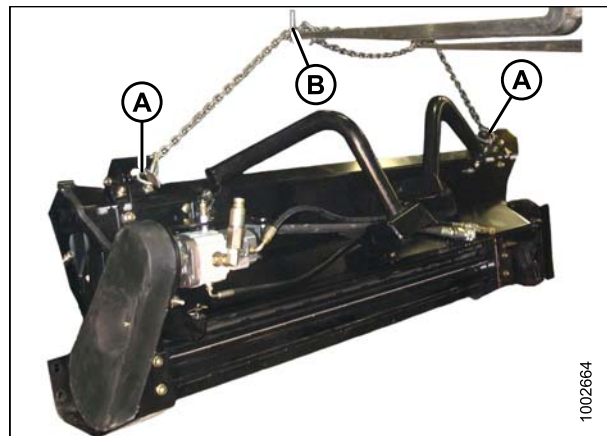

Figure 4.20: Conditioner and Lifting Brackets

8. Carefully raise the lifting device until lugs (A) on conditioner clear the U-shaped brackets (B) on header.
9. Slowly back windrower away from header.

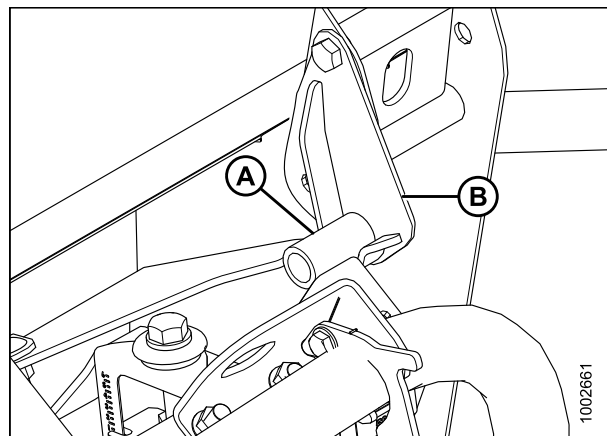

Figure 4.21: Conditioner Lug

OPERATION

10. Retrieve stand (A) from toolbox and install in slot at bottom of conditioner base. Secure with hairpin (B).
11. Lower conditioner to ground.
12. Unhook chains.

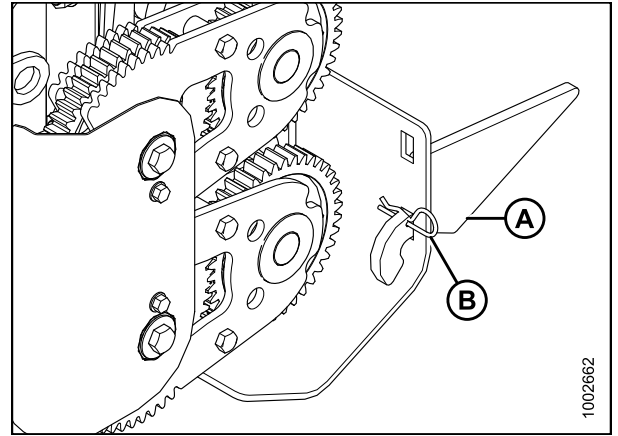

Figure 4.22: Conditioner Stand

4.5 Detaching Feed Deck and Rock Grate

To detach the feed deck and rock grate from the hay conditioner, follow these steps:

1. Remove the two carriage bolts (A) that attach the hose brace to the header and lay hoses on deck.
2. Remove the two bolts (A) at the rear of the deck that secure the deck to the header.

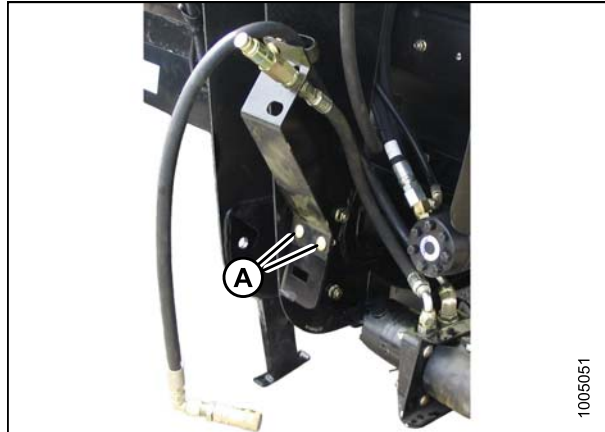

Figure 4.23: Hose Brace

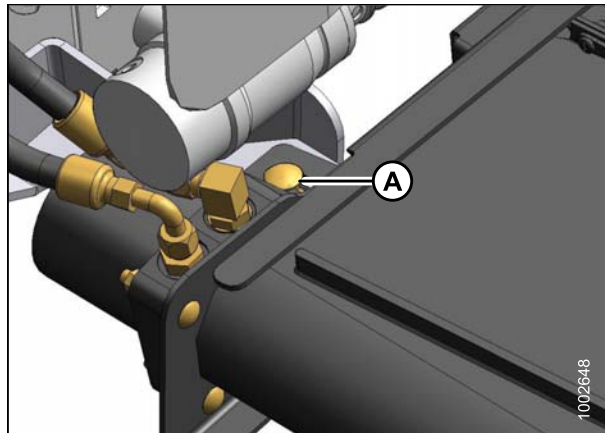

Figure 4.24: Feed Deck – LH Side

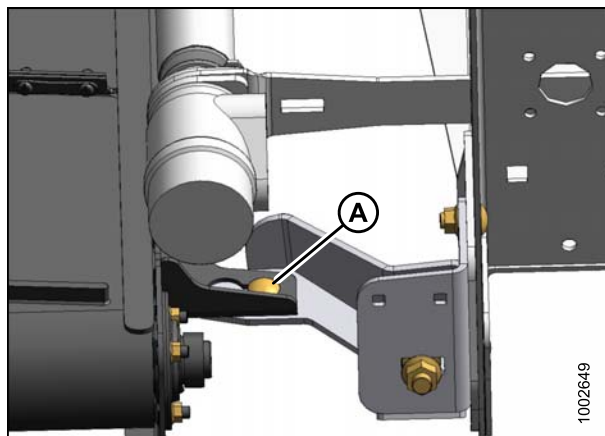

Figure 4.25: Feed Deck – RH Side

OPERATION

3. Slide deck (A) back slightly until deck mounts clear the header brackets. Lower aft of deck to ground.
4. Continue sliding deck back until deck drops free of rock grate. Move deck to storage.

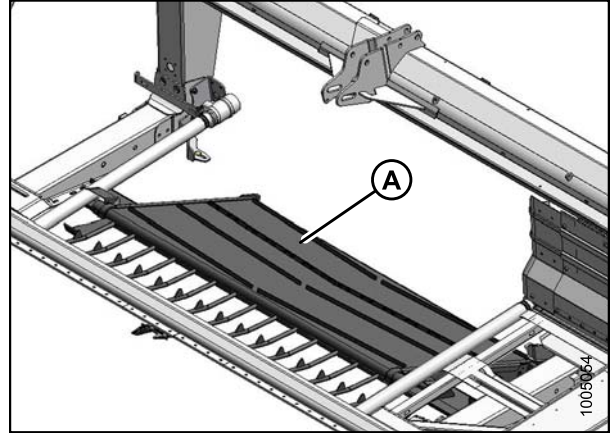

Figure 4.26: Feed Deck

5. Remove the two bolts (A) attaching rock grate to header legs.

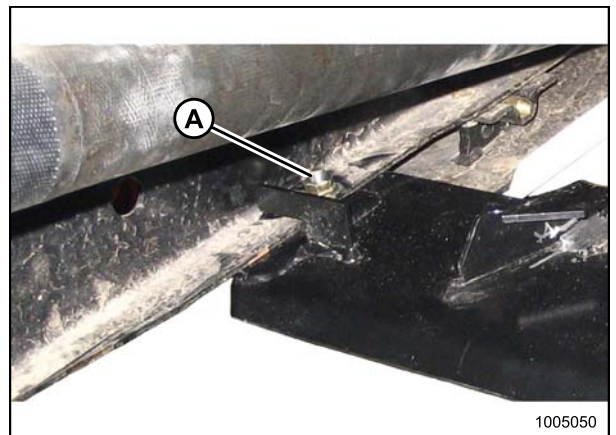

Figure 4.27: Rock Grate

6. Pull rock grate (A) off cutterbar and header legs. Move rock grate to storage.

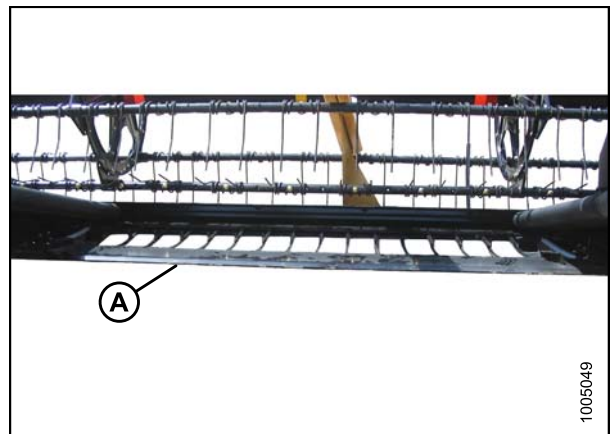

Figure 4.28: Rock Grate

OPERATION

7. If necessary, remove the conditioner attachment brackets (A) and spacers (B) from the header legs and store with the feed deck.

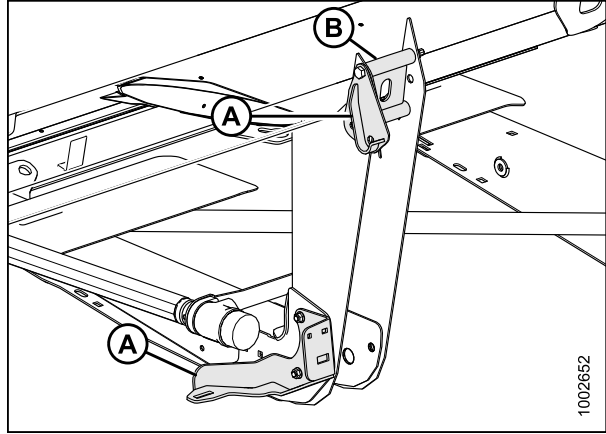

Figure 4.29: Conditioner Attachment Brackets

4.6 Break-in Period

When operating the hay conditioner for the first time, operate the conditioner slowly for five minutes, watching and listening FROM THE OPERATOR'S SEAT for binding or interfering parts.

CAUTION

Before investigating an unusual sound or attempting to correct a problem, shut off engine, engage parking brake, and remove key.

NOTE:

Conditioner will **NOT** operate until oil flow fills the lines.

NOTE:

Until you become familiar with the sound and feel of your new hay conditioner, be extra alert and attentive.

After First Five Hours of Operation:

- Adjust the tension of roll drive belt. Refer to [5.7 Drive Belt, page 96](#). Continue to check the belt tension periodically for the first 50 hours.
- Tighten any loose hardware. Refer to [2 General Information, page 9](#).

4.7 Preseason Check

CAUTION

- Review the operator's manual to refresh your memory on safety and operating recommendations.
- Review all safety signs and other decals on the header and note hazard areas.
- Be sure all shields and guards are properly installed and secured. Never alter or remove safety equipment.
- Be sure you understand and have practiced safe use of all controls. Know the capacity and operating characteristics of the machine.
- Check the first aid kit and fire extinguisher. Know where they are and how to use them.

Perform the following tasks at the beginning of each operating season:

- Adjust tension on drive belt. Refer to [5.7 Drive Belt, page 96](#).
- Perform all annual maintenance. Refer to [5.8 Maintenance Schedule, page 102](#).

4.8 Daily Startup Check

CAUTION

- Clear the area of other persons, pets, etc. Keep children away from machinery. Walk around the machine to be sure no one is under, on, or close to it.
- Wear close-fitting clothing and protective shoes with slip-resistant soles.
- Remove foreign objects from the machine and surrounding area.
- As well, carry with you any protective clothing and personal safety devices that **COULD** be necessary through the day. Don't take chances. You may need a hard hat, protective glasses or goggles, heavy gloves, a respirator or filter mask, or wet weather gear.
- Protect against noise. Wear a suitable hearing protective device such as ear muffs or ear plugs to protect against objectionable or uncomfortable loud noises.

Complete the following tasks each day before start-up:

1. Check the machine for leaks or any parts that are missing, broken, or not working correctly.

NOTE:

Use proper procedure when searching for pressurized fluid leaks. Refer to [5.5 Hydraulics, page 94](#).

2. Clean all lights and reflective surfaces on the machine.
3. Perform all daily maintenance. Refer to [5.8 Maintenance Schedule, page 102](#).

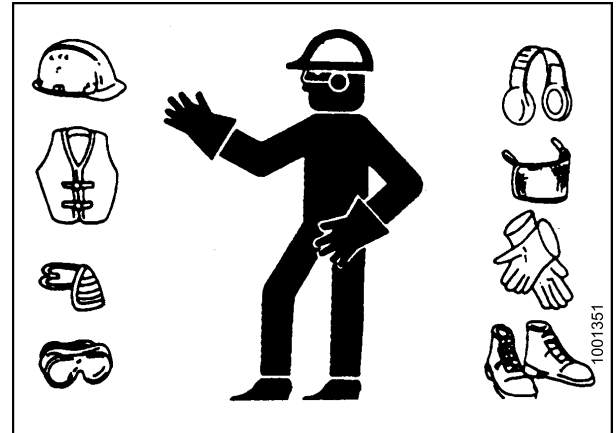

Figure 4.30: Protective clothing and personal safety devices

4.9 Conditioner Operation

WARNING

Keep hands and feet away from discharge opening. Keep everyone several hundred feet away from your operation. Never direct the discharge toward anyone. Stones or other foreign objects can be ejected with force.

WARNING

To avoid bodily injury or death from unexpected startup of machine, stop engine and remove key before adjusting rolls.

4.9.1 Roll and Feed Draper Speed

The roll and feed draper speeds change whenever the header knife speed is changed since the drives use the same hydraulic circuit. They cannot be independently adjusted.

4.9.2 Adjusting Roll Gap

Intermeshing steel rolls condition the crop by crimping and crushing the stem in several places. This allows moisture release for quicker drying. The degree to which the crop is conditioned as it passes through the rolls is controlled by roll gap (refer to illustration at right). The gap is factory set at 3/4 in. (20 mm) or at 1.5 line on gauge. Gauge readings should be the same at both ends of the roll.

Correct conditioning of alfalfa, clover, and other legumes is usually indicated when 90% of the stems show cracking, but no more than 5% of the leaves are damaged. Use only enough roll gap to achieve this result.

Grass type crops may require less gap for proper feeding and conditioning. A larger gap (up to 1 inch [25 mm]) may be desirable in thick-stemmed cane-type crops; however, too large a gap may cause feeding problems.

If required, you can adjust the roll gap by loosening nut (A) and turning adjuster (B). Retighten nut (A) after adjusting.

IMPORTANT:

When adjusting roll gap, be sure that the gauge (C) reading is the same on both sides of the conditioner roll to achieve consistent intermesh across the rolls.

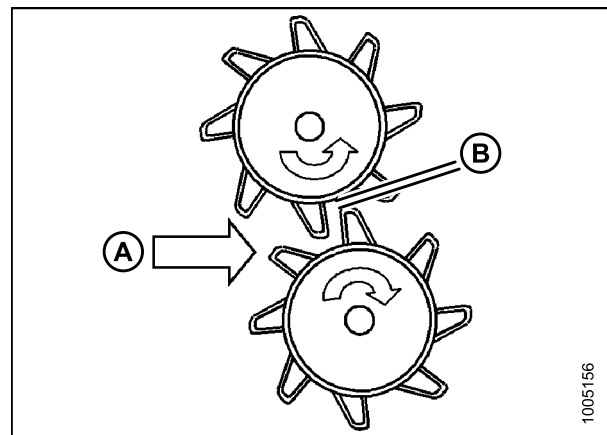

Figure 4.31: Roll Gap

A - Crop Direction

B - Roll Gap

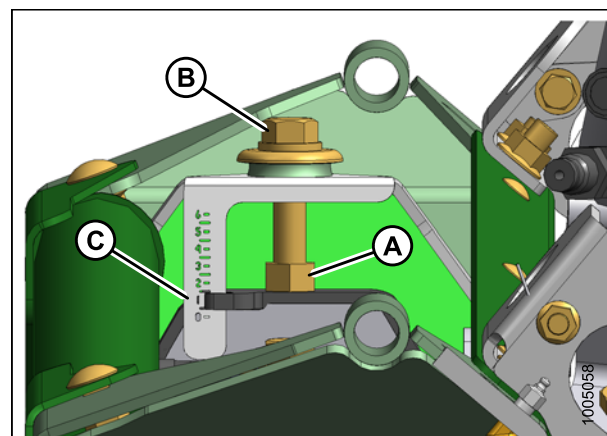

Figure 4.32: Roll Gap Gauge

4.9.3 Checking and Adjusting Roll Timing

For proper conditioning, the rolls must be properly timed and aligned with each steel bar on one roll centered between two bars of the other roll as shown in Figure 4.33: [Roll Timing Tool](#), page 83. The factory setting should be suitable for most crop conditions.

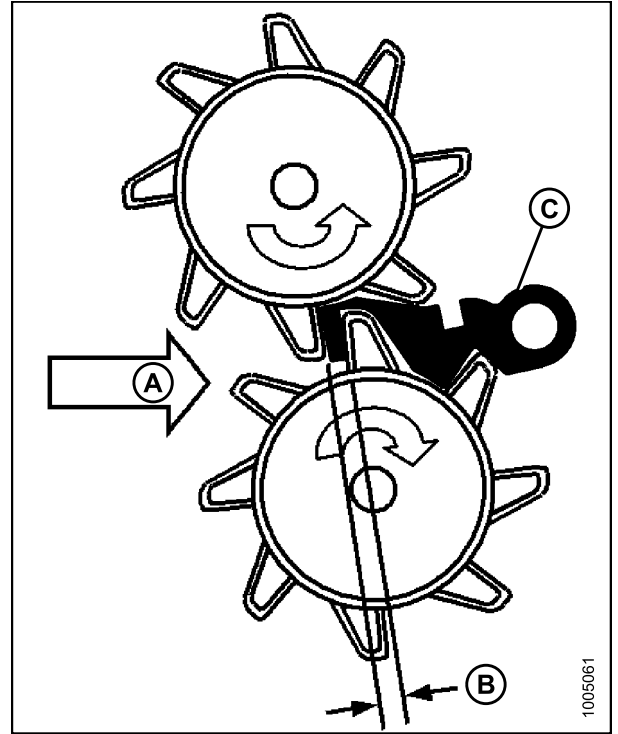

Figure 4.33: Roll Timing Tool

A - Crop Direction B - Timing Gap
C - Roll Timing Tool

To check roll timing, follow these steps:

1. Lower header to ground, shut down windrower, and remove key.
2. Remove wing nut and washer (A) and remove tool (B) from panel at right-hand end of conditioner.

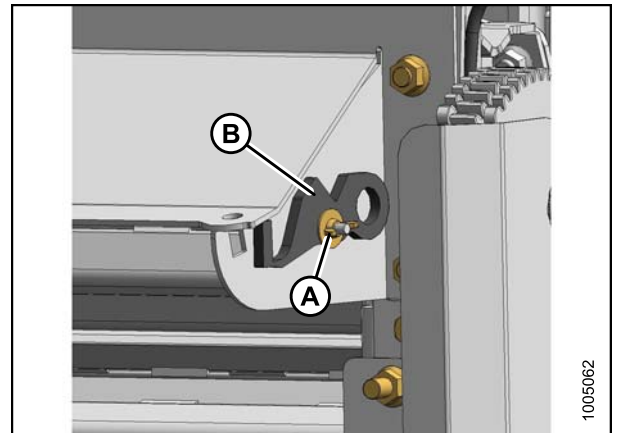

Figure 4.34: Conditioner End – RH

OPERATION

- From the rear of the conditioner, position tool at center of rolls as shown above right (A) and manually turn rolls to limits of tool. Rolls will engage the tool if timing is correct.
- Manually turn rolls to release tool.

WARNING

Remove tool from rolls and return it to storage location before starting machine.

- Replace tool on conditioner with washer and wing nut.
- If roll timing is correct, skip remaining steps. If roll timing needs adjusting, continue to the next step.

- Loosen the four bolts (A) on one of the small timing gears.
- Insert tool as described above and allow rolls to adjust to tool.
- Tighten bolts on timing gear.
- Return tool to storage position.



Figure 4.35: Roll Timing Tool

A - Start Position

B - Gauge Position

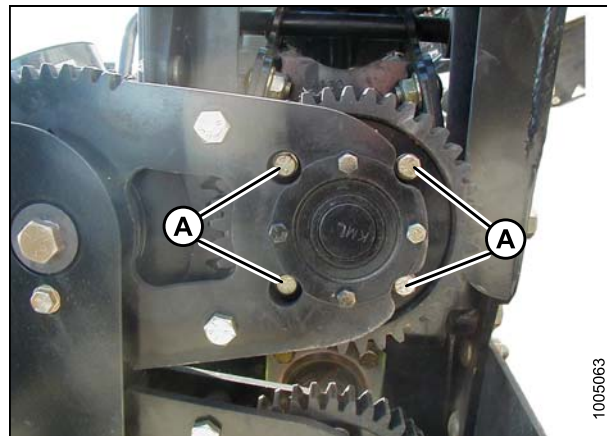

Figure 4.36: Timing Gear

4.9.4 Adjusting Conditioner Roll Tension

The conditioner roll tension is maintained by two tension springs providing adequate pressure for correct conditioning of the crop. These springs also allow the rolls to open to allow passage of small solid objects without damage to the rolls.

- Locate the adjustment nuts on top of the conditioner channel.
- Loosen jam nuts (A).
- Turn adjusting nut (B) clockwise to increase tension, and counterclockwise to decrease tension.
- Adjust nuts (B) on both sides equal amounts.
- Tighten jam nut (A).

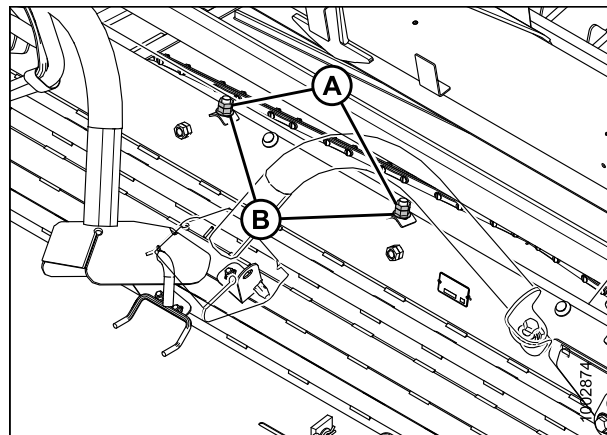

Figure 4.37: Conditioner Channel

4.9.5 Forming Shields

The position of the forming shields controls the width and placement of the windrow. The decision on forming shield position (settings between 36 and 92 in. [915 and 2346 mm]) should be based on the following factors:

- Weather conditions (rain, sun, humidity, wind)
- Type and yield of crop
- Drying time available
- Method of processing (bales, silage, "green-feed")

A wider windrow will generally dry faster and more evenly, resulting in less protein loss. Fast drying is especially important in areas where the weather allows only a few days to cut and bale.

Where weather conditions permit or when drying is not critical, for example, when cutting for silage or "green-feed", a narrower windrow may be preferred for ease of pick-up.

OPERATION

Adjusting Forming Shield Height

⚠ WARNING

Stop engine and remove key before making adjustments to machine. A child or even a pet could engage the drive.

The height of the forming shield affects the shape and consistency of the windrow. A heavy crop will require the forming shield to be set near the highest position and a lighter crop needs the forming shield to be lower. Adjust the forming shield height as follows:

1. Remove hairpins (A) securing straps (B) to pins on windrower frame.
2. Support aft end of forming shield and relocate straps to the desired hole.
3. Secure straps with hairpins.

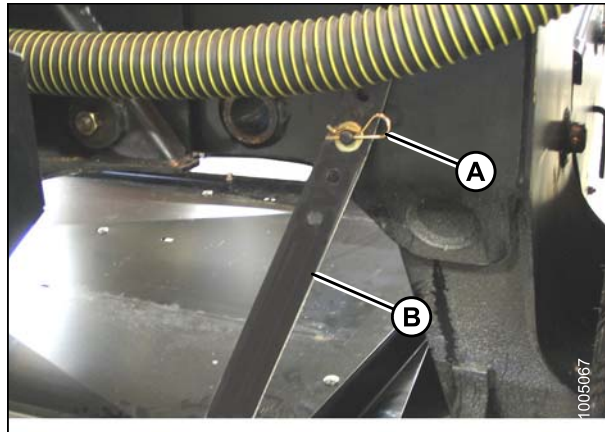

Figure 4.38: Rubber Strap

Adjusting Side Deflectors

⚠ WARNING

Stop engine and remove key before making adjustments to machine. A child or even a pet could engage the drive.

The position of the side deflectors controls the width and placement of the windrow. To adjust the position, follow these steps:

1. Set side deflectors (A) to desired width by loosening handle (B) and moving deflector (A). Tighten handle. Set both deflectors to approximately the same position.

IMPORTANT:

To ensure windrow placement is centered with respect to windrower wheels, adjust both side deflectors to the same position. To achieve this setting, adjuster handles must be in the same location on both sides.

2. If side deflector attachment is too tight or too loose, tighten or loosen nut (C) as required.

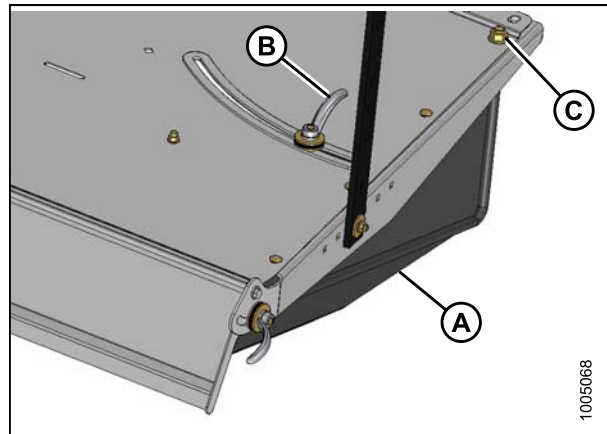

Figure 4.39: Side Deflector – RH

OPERATION

Adjusting Rear Deflector (Fluffer Shield)

WARNING

Stop engine and remove key before making adjustments to machine. A child or even a pet could engage the drive.

The rear deflector (A) slows the crop exiting the conditioner rolls, directs the flow downward, and "fluffs" the material. To adjust the rear deflector, follow these steps:

1. For more crop control in light material, lower the deflector by pushing down on one side of the deflector and then down on the other side. Locking bolts (B) are located at either end of the deflector and may be loosened slightly.
2. For heavier crops, raise the deflector by pulling up on one side and then up on the other side.

NOTE:

For even windrow formation, be sure the deflector is not twisted.

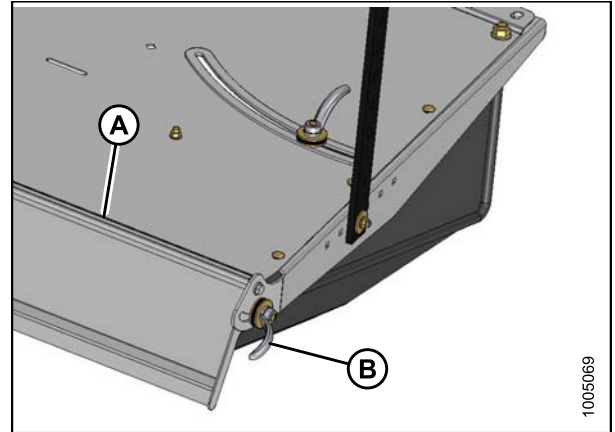

Figure 4.40: Rear Deflector

Adjusting Deflector Fins

WARNING

Stop engine and remove key before making adjustments to machine. A child or even a pet could engage the drive.

Adjustable deflector fins help to provide different swath widths and distribution of crop across the windrow.

Angles for the short fins (A) can be adjusted by loosening mounting bolt(s) and rotating as required. The long fins (B) can be adjusted using the slots in the cover.

Set fins approximately parallel to side deflectors for wide swath and adjust as required for even distribution of crop across full width. For narrow windrow less than 70 in. (1780 mm), remove fins.

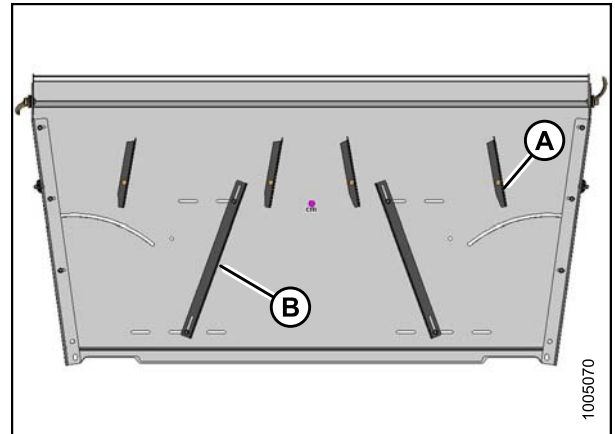

Figure 4.41: Deflector Fins

4.9.6 Unplugging the Conditioner

To unplug the conditioner, reverse the header drive. Refer to the windrower operator's manual for procedures on reversing the header drive.

4.10 Storing the Hay Conditioner

At the end of each operating season, perform the following maintenance items:

- Clean the conditioner thoroughly.

CAUTION

Never use gasoline, naphtha, or any volatile material for cleaning purposes. These materials may be toxic and/or flammable.

- Store in a dry, protected place if possible. If stored outside, always cover conditioner with a waterproof canvas or other protective material.
- Repaint all worn or chipped painted surfaces to prevent rust.
- Loosen drive belt.
- Lubricate the conditioner thoroughly, leaving excess grease on fittings to keep moisture out of bearings. Apply grease to exposed threads and sliding surfaces of components.
- Check for worn components and repair.
- Check for broken components and order replacement from your dealer. Attention to these items right away will save time and effort at beginning of next season.
- Replace or tighten any missing or loose hardware. Refer to [2 General Information, page 9](#)

5 Maintenance

5.1 Preparation for Servicing

The following instructions are provided to help you maintain your HC10 Hay Conditioner.

Contact your MacDon Dealer for detailed maintenance and service information.

CAUTION

To avoid personal injury, before servicing hay conditioner or opening header drive covers:

1. **Fully lower the header. If necessary to service in the raised position, always engage safety props.**
2. **Stop engine and remove key.**
3. **Engage park brake.**
4. **Wait for all moving parts to stop.**

5.2 Recommended Safety Procedures

Always follow these recommended safety procedures:

- Park on a level surface when possible. Block wheels securely if windrower is parked on an incline.
- Follow all recommendations in your header and windrower operator's manuals.
- Follow all safety sections in this manual. Refer to [1 Safety, page 1](#).

5.3 Removing and Installing Driveshields

CAUTION

- Keep all shields in place. Never alter or remove safety equipment.
 - Do NOT operate machine with shield removed.
1. To remove shield, undo wing nut (B) and remove washer. Pull shield (A) off conditioner.
 2. To install shield, position shield (A) over drive pulleys and then secure with washer and wing nut (B).

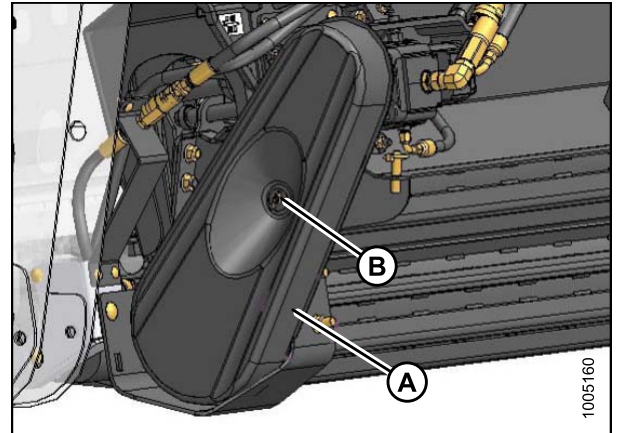

Figure 5.1: Driveshield

5.4 Lubrication

5.4.1 Lubricants

Use clean lubricants to keep your machine operating at top efficiency.

Use clean containers to handle all lubricants.

Store in an area protected from dust, moisture, and other contaminants.

Lubricant	Spec.	Description	Use
Grease	SAE Multi-Purpose	High temperature, extreme pressure (EP) 0-1% Max Molybdenum Disulphide (NLGI Grade 2) Lithium Complex Base Base Oil Viscosity of 190-250 CST @ 40C	As required unless otherwise specified

5.4.2 Greasing Procedure

CAUTION

To avoid personal injury, before servicing header or opening drive covers, follow procedures in [5.1 Preparation for Servicing, page 89](#).

1. To avoid injecting dirt and grit, wipe grease fitting with a clean cloth before greasing. For various locations of grease fittings, refer to [3.12.2 Lubrication Points, page 59](#).
2. Inject grease through fitting with grease gun until grease overflows fitting, except where noted. For detailed lubrication information, refer to [5.4 Lubrication, page 92](#).
3. Leave excess grease on fitting to keep out dirt.
4. Replace any loose or broken fittings immediately.
5. If fitting will not take grease, remove and clean thoroughly. Also clean lubricant passageway. Replace fitting if necessary.

5.4.3 Greasing Points

Greasing points that have greasing intervals of 50 hours or less are marked on the machine by decals showing a grease gun (A) and grease interval (B) in hours of operation.

Log hours of operation and use the Maintenance Checklist provided to keep a record of scheduled maintenance. Refer to [5.8 Maintenance Schedule, page 102](#).

To identify the various locations that require lubrication, refer to [3.12.2 Lubrication Points, page 59](#).

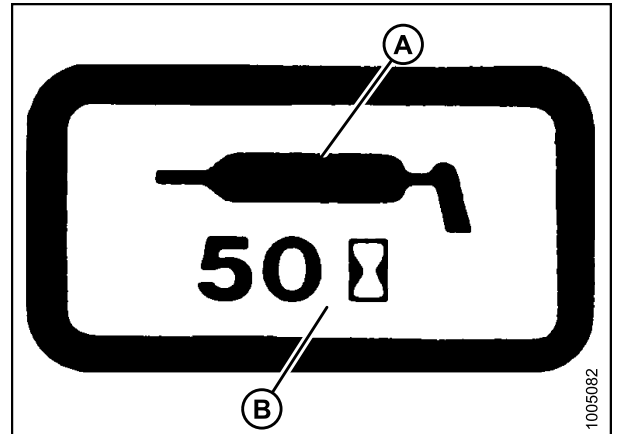

Figure 5.2: Grease Decal – 50 Hours

5.5 Hydraulics

5.5.1 Hydraulic Hoses and Lines

Check hydraulic hoses and lines daily for signs of leaks.

WARNING

- Avoid high-pressure fluids. Escaping fluid can penetrate the skin causing serious injury. Relieve pressure before disconnecting hydraulic lines. Tighten all connections before applying pressure. Keep hands and body away from pin holes and nozzles which eject fluids under high pressure.
- If ANY fluid is injected into the skin, it must be surgically removed within a few hours by a doctor familiar with this type of injury or gangrene may result.
- Use a piece of cardboard or paper to search for leaks.

IMPORTANT:

Keep hydraulic coupler tips and connectors clean. Dust, dirt, water, and foreign material are the major causes of hydraulic system damage. DO NOT attempt to service hydraulic system in the field. Precision fits require WHITE ROOM CARE during overhaul.



Figure 5.3: Hydraulic Pressure Hazard

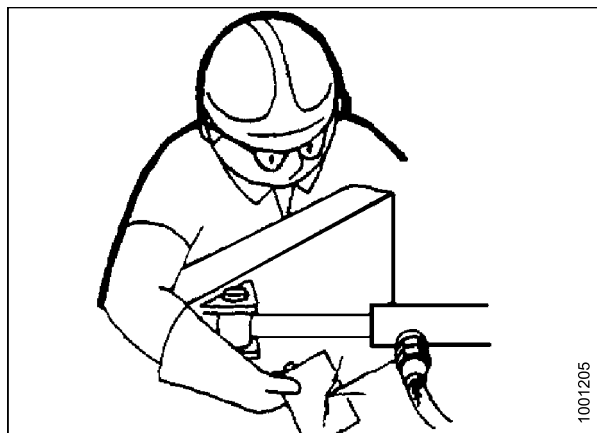

Figure 5.4: Safety Around Equipment

5.5.2 Hydraulic Schematics

For detailed hydraulic schematics, refer to [3.8 Header Schematics, page 50](#).

5.6 Feed Draper

5.6.1 Adjusting Feed Draper Tension

DANGER

To avoid bodily injury or death from unexpected start-up or fall of raised machine, always stop engine, remove key, and engage safety props before going under header for any reason. Refer to your windrower operator's manual for instructions for use and storage of safety props.

CAUTION

Stop engine and remove key from ignition before leaving Operator's seat for any reason. A child or even a pet could engage an idling machine.

Feed draper tension should be just enough to prevent slipping and keep draper from sagging below cutterbar. Set draper tension as follows:

1. Raise header fully, stop engine, and remove key. Engage safety props.
2. Check that draper guide (rubber track on underside of draper [A]) is properly engaged in groove of drive roller (B) and that idler roller (C) is inboard of the draper guide.

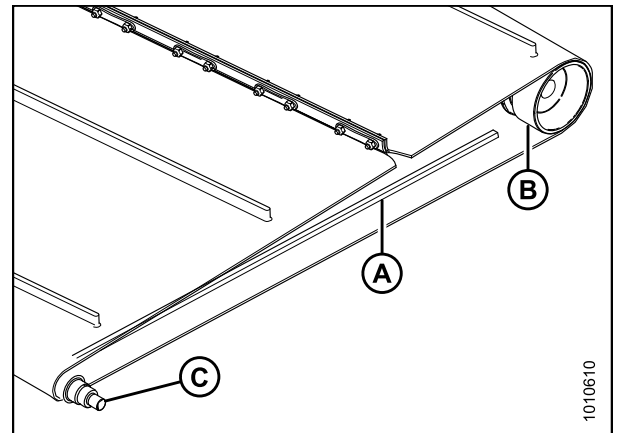

Figure 5.5: Draper Guide

3. Loosen jam nut (A).
4. Hold nut (B) with a wrench and turn bolt (C) clockwise to increase tension and counterclockwise to decrease tension.
5. Correct tension is when retainer (D) is flush with spring holder, and bolt (E) is free.
6. Tighten jam nut (A).
7. Perform equal adjustment on both sides of draper.

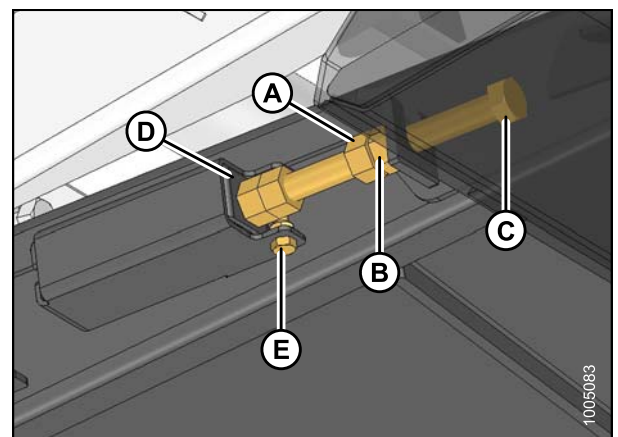

Figure 5.6: Tension Adjustment Hardware

5.7 Drive Belt

5.7.1 Adjusting Drive Belt Tension

1. Remove wing nut and washer (A) and remove drive cover (B).

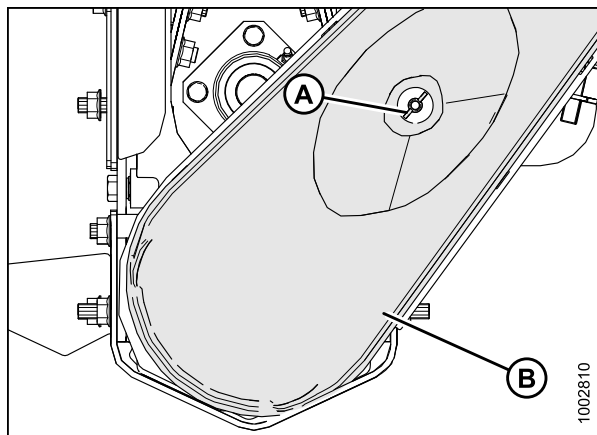

Figure 5.7: Drive Belt Cover

2. Belt (A) should deflect 1/4 in. (7 mm) when a force of 8–16 lbf (36–72 N) is applied at the center of the span.

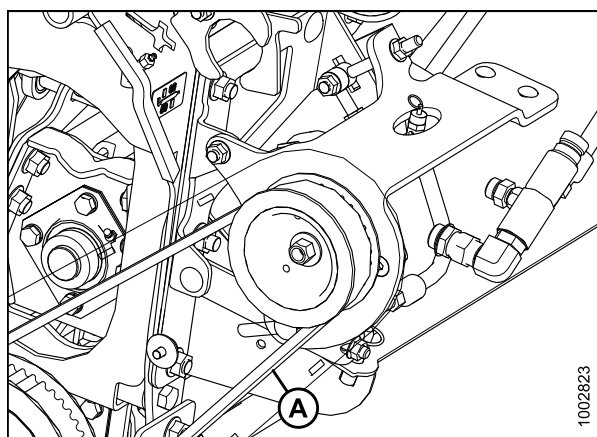

Figure 5.8: Drive Pulley

3. Loosen three motor mount bolts (A).
4. Turn tensioning nut (B) clockwise to tighten belt and counterclockwise to loosen.
5. Tighten the three motor mount bolts (A).
6. Recheck the belt (C) tension.

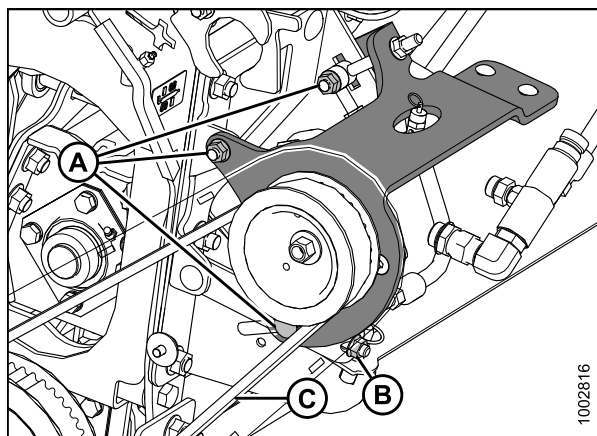

Figure 5.9: Drive Pulley

MAINTENANCE

7. Replace cover (B) and secure with washer and wing nut (A).
8. Readjust tension of a new belt after a short run-in period (about 5 hours).

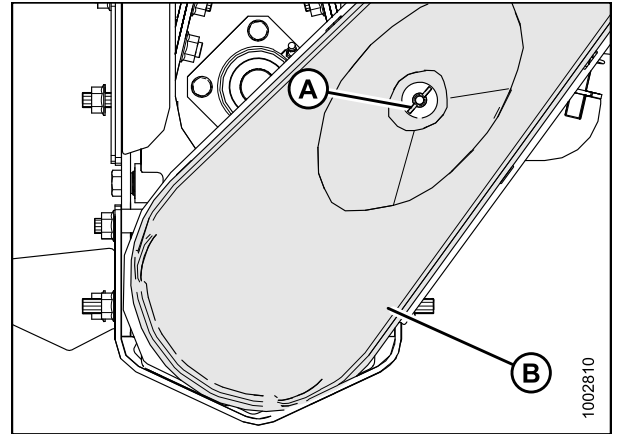

Figure 5.10: Drive Belt Cover

5.7.2 Adjusting Drive Belt Pulley Alignment

Pulleys should be aligned so that the belt tracks properly. If necessary, adjust as follows:

1. Remove wing nut (A) and washer and remove drive cover (B).
2. Loosen nut (A).
3. Adjust nuts (B) to align the drive pulley horizontally.
4. Adjust nuts (C) to align the drive pulley vertically.
5. Tighten nut (A).

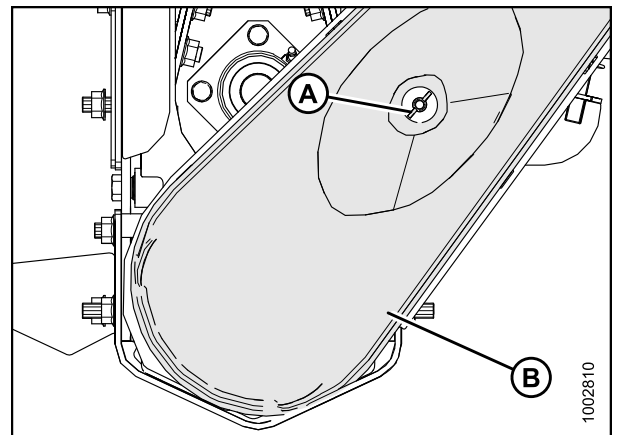

Figure 5.11: Drive Belt Cover

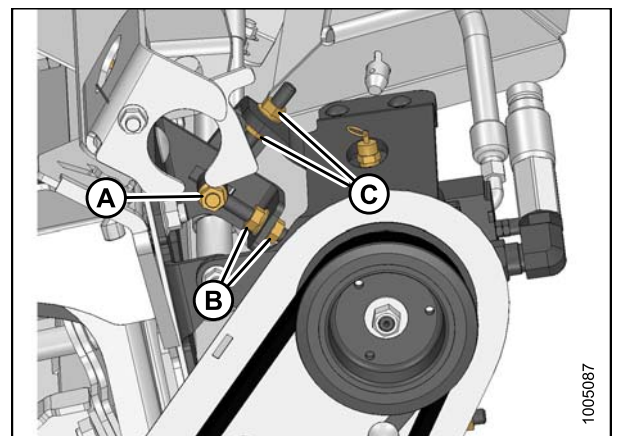

Figure 5.12: Drive Pulley

MAINTENANCE

6. Replace cover (B) and secure with washer and wing nut (A).

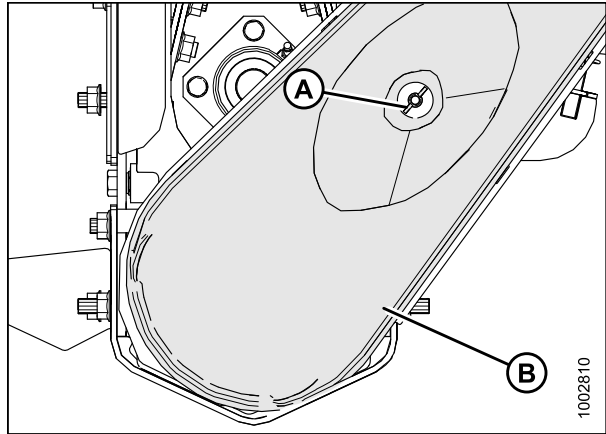

Figure 5.13: Drive Belt Cover

5.7.3 Checking and Adjusting Drive Belt Tracking

Proper tracking of the belt ensures there is no rubbing of the belt on either pulley.

1. Remove wing nut (A) and washer and remove drive cover (B).

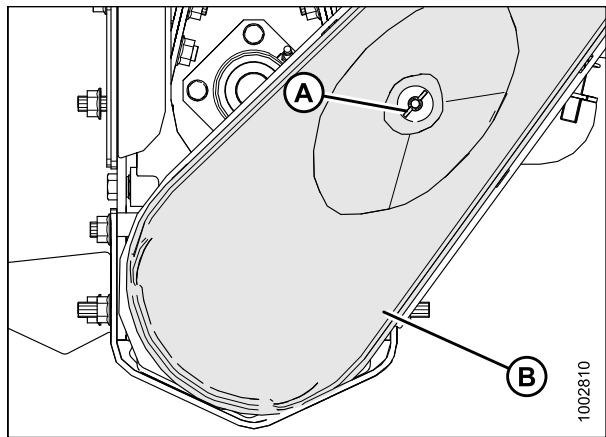

Figure 5.14: Drive Belt Cover

2. Check the belt and both pulleys (A) for evidence of belt rubbing.

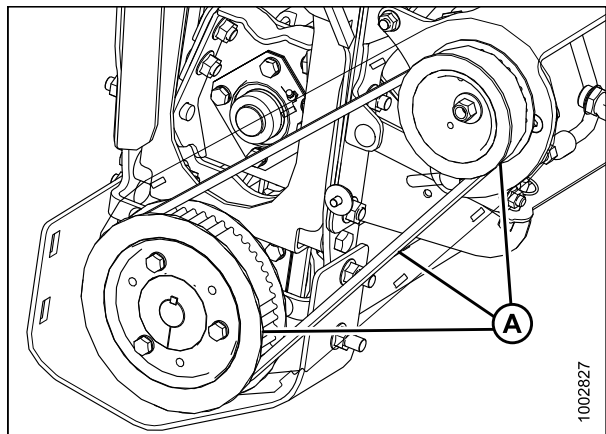

Figure 5.15: Drive Belt and Pulleys

MAINTENANCE

- Using a straight edge (A), place it across the face of the driving and driven pulley. Check that the pulleys are aligned.

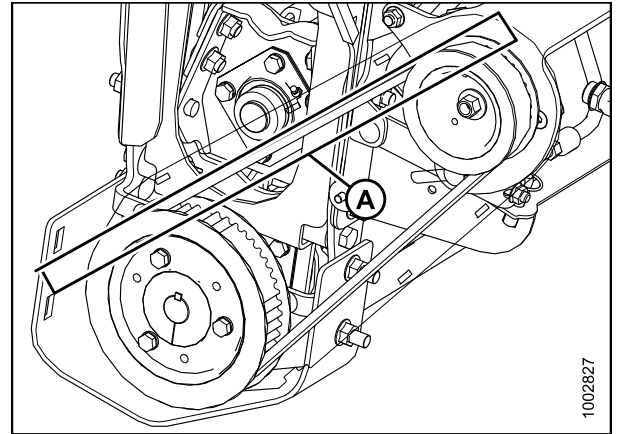

Figure 5.16: Drive Belt and Pulleys

- Adjust the driving pulley by loosening nut (A).
- Adjust nuts (B) to align the drive pulley horizontally. If belt is tracking to the outside of the pulley, turn jam nuts (B) clockwise.
- Adjust nuts (C) to align the drive pulley vertically. If belt is tracking to the inside of the pulley, turn jam nuts (C) counterclockwise.
- Tighten nut (A).

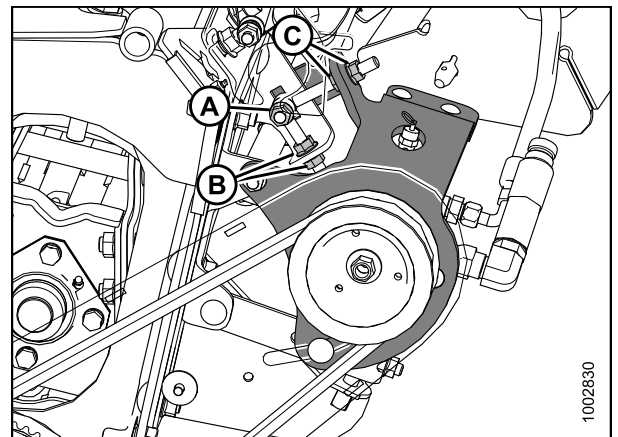

Figure 5.17: Drive Pulley

- Run the conditioner to verify the belt is now tracking correctly.
- Replace cover (B) and secure with washer and wing nut (A).

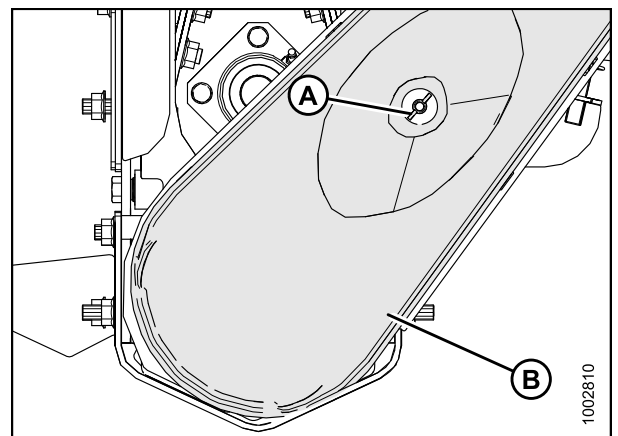

Figure 5.18: Drive Belt Cover

5.7.4 Removing Drive Belt

1. On the left-hand side, remove the wing nut and washer (A), then remove drive cover (B).

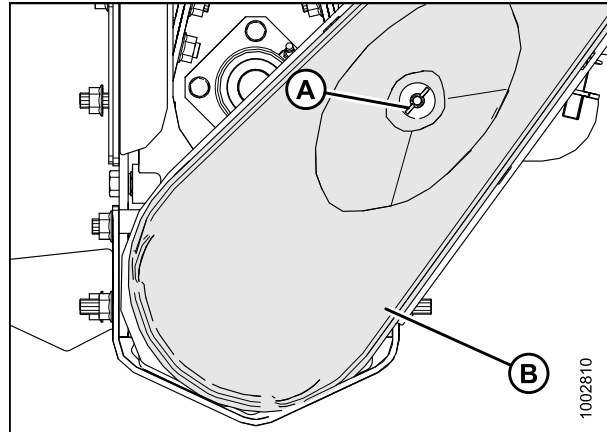

Figure 5.19: Drive Belt Cover

2. Loosen three motor mount bolts (A).
3. Turn tensioning nut (B) counterclockwise to loosen.
4. Remove the belt (C).

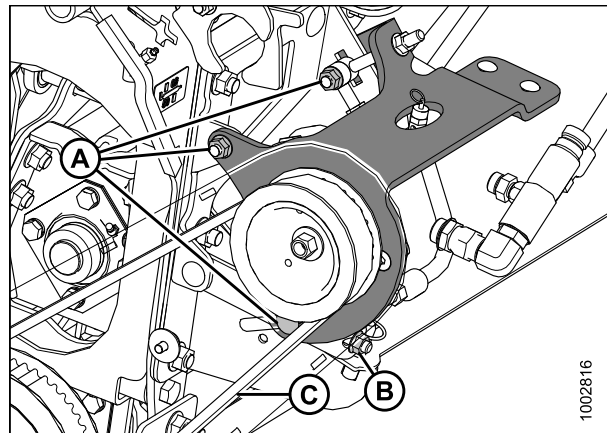

Figure 5.20: Motor Mount

5.7.5 Installing Drive Belt

NOTE:

Refer to [5.7.3 Checking and Adjusting Drive Belt Tracking, page 98](#) before installing a new belt to check possible cause of failure.

MAINTENANCE

1. Install belt (A) onto pulleys.

NOTE:

When installing new belt, never pry belt over pulley. Be sure adjusting device is fully loosened, then tension belt.

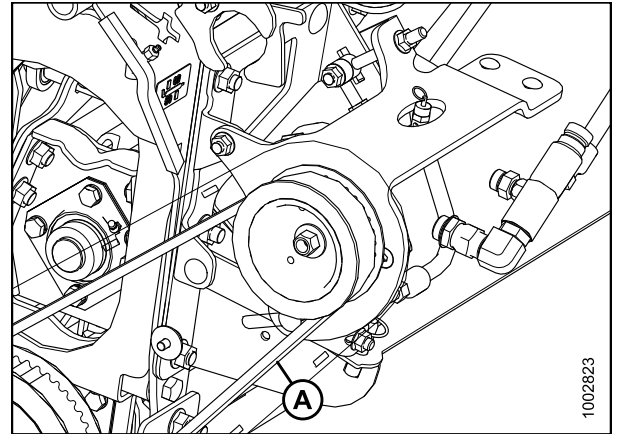

Figure 5.21: Drive Pulley

2. Loosen three motor mount bolts (A).
3. Turn tensioning nut (B) clockwise to tighten belt and counterclockwise to loosen.
4. Tighten the three motor mount bolts (A).
5. Recheck the belt (C) tension.

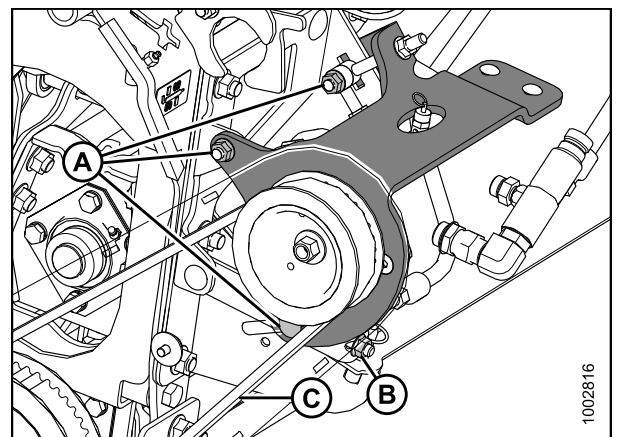

Figure 5.22: Drive Pulley

6. Replace cover (B) and secure with washer and wing nut (A).
7. Readjust tension of a new belt after a short run-in period (about 5 hours).

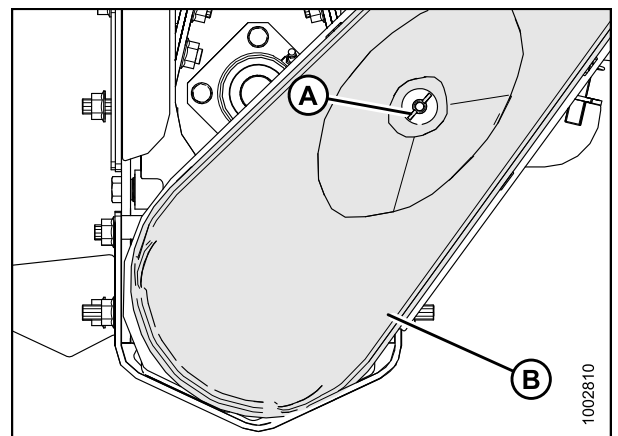

Figure 5.23: Drive Belt Cover

5.8 Maintenance Schedule

The following maintenance schedule is a listing of periodic maintenance procedures, organized by service intervals. Regular maintenance is the best insurance against early wear and untimely breakdowns. Following this schedule will increase machine life. For detailed instructions, refer to the specific headings in this manual. Use the lubricant specified in [5.4.1 Lubricants, page 92](#).

Service Intervals: The recommended service intervals are in hours of operation. Where a service interval is given in more than one time frame, e.g., "100 hours or Annually", service the machine at whichever interval is reached first.

IMPORTANT:

Recommended intervals are for average conditions. Service the machine more often if operated under adverse conditions (severe dust, extra heavy loads, etc.).

 **CAUTION**

Carefully follow safety messages given under [5.1 Preparation for Servicing, page 89](#) and [5.2 Recommended Safety Procedures, page 90](#).

Table 5.1 Service Intervals

Interval	Service
First use	Refer to 4.6 Break-in Period, page 79 .
10 hours or daily	Check hydraulic hoses and lines.
50 hours	Grease roll shaft bearings. Grease feed deck drive and idler roller bearings.
100 hours or annually ⁸	Check roll drive belt tension.
End of season	Refer to 4.10 Storing the Hay Conditioner, page 88 .

8. It is recommended that annual maintenance be done prior to the start of the operating season.

MAINTENANCE

5.9 Troubleshooting

Symptom	Problem	Solution	Section
Hay conditioner rolls will not turn	There is an obstruction or wad in the conditioner rolls	Turn mechanism in reverse and remove wad	4.9.6 Unplugging the Conditioner, page 87
	Drive belt is broken	Replace drive belt	5.7.4 Removing Drive Belt, page 100 and 5.7.5 Installing Drive Belt, page 100
	Drive belt is too loose	Tighten or replace conditioner drive belt	5.7.4 Removing Drive Belt, page 100 and 5.7.5 Installing Drive Belt, page 100
Crop is over-conditioned	Roll gap is too small	Increase roll gap	4.9.2 Adjusting Roll Gap, page 82
	Roll timing is off	Adjust roll timing	4.9.3 Checking and Adjusting Roll Timing, page 83
Crop is under-conditioned	Roll gap is too large	Reduce roll gap	4.9.2 Adjusting Roll Gap, page 82
	Roll timing is off	Adjust roll timing	4.9.3 Checking and Adjusting Roll Timing, page 83
Windrow is too wide	Forming shield side deflectors are too far apart	Position deflectors closer together	Adjusting Side Deflectors, page 86
Windrow is too narrow	Forming shield side deflectors are too close together	Position deflectors farther apart	Adjusting Side Deflectors, page 86
	Deflector fins inside forming shield are improperly adjusted	Adjust fins	Adjusting Deflector Fins, page 87
Windrow is uneven	Forming shield is too low	Raise forming shield	Adjusting Forming Shield Height, page 86
	Deflector fins inside forming shield are improperly adjusted	Adjust fins	Adjusting Deflector Fins, page 87
	Overlap of side drapers and feed deck is inadequate	Adjust overlap	3.5 Installing the Feed Deck, page 35

MAINTENANCE

Symptom	Problem	Solution	Section
Windrow lacks shape	Forming shield is too high	Lower forming shield	<i>Adjusting Forming Shield Height, page 86</i>
	Deflector fins inside forming shield are improperly adjusted	Adjust fins	<i>Adjusting Deflector Fins, page 87</i>
Feed draper is not tracking properly	Feed draper tensioners are improperly adjusted	Check feed draper tension and adjust accordingly	<i>5.6.1 Adjusting Feed Draper Tension, page 95</i>
Side draper is backfeeding	Overlap of side drapers and feed deck is inadequate	Adjust overlap	<i>3.5 Installing the Feed Deck, page 35</i>

6 Repair Parts

This chapter lists all the replacement parts that can be ordered for a MacDon HC10 Hay Conditioner.

Bold text is used to indicate updates made at the current revision level. With each new revision of the catalog, previous revisions are returned to regular text.

In this catalog, right-hand (RH) and left-hand (LH) are determined from the Operator's position, facing forward with the windrower in cab-forward position. An arrow is sometimes used in illustrations to indicate cab-forward position.

6.1 Abbreviations

The following abbreviations are used in this catalog.

A/R – as required (quantity varies)
C/W – complete with
CSK – countersink
DK – double knife
DT – distorted thread
FLG – flange
I.D. – inside diameter
LH – left hand (Determined from Operator's position, facing forward.)
NC – national coarse thread
NF – national fine thread
NSS – not serviced separately
O.D. – outside diameter
OPT – optional
REF – reference, part number called up elsewhere in catalog
RH – right hand
RHSN – round head, square neck or square neck carriage bolt
RHSSN – round head, short, square neck
SMV – slow moving vehicle
SP – self-propelled header
PT – pull-type header

6.1.1 Serial Number Breaks

The side of the serial number on which the dash (–) appears determines whether the part is used "up to" or "after" the serial number given.

Example:

- –162249 Used on machines up to and including serial number 166249.
- 166250– Used on machines including and after serial number 166250.

6.2 Lower Roll and Frame Assembly

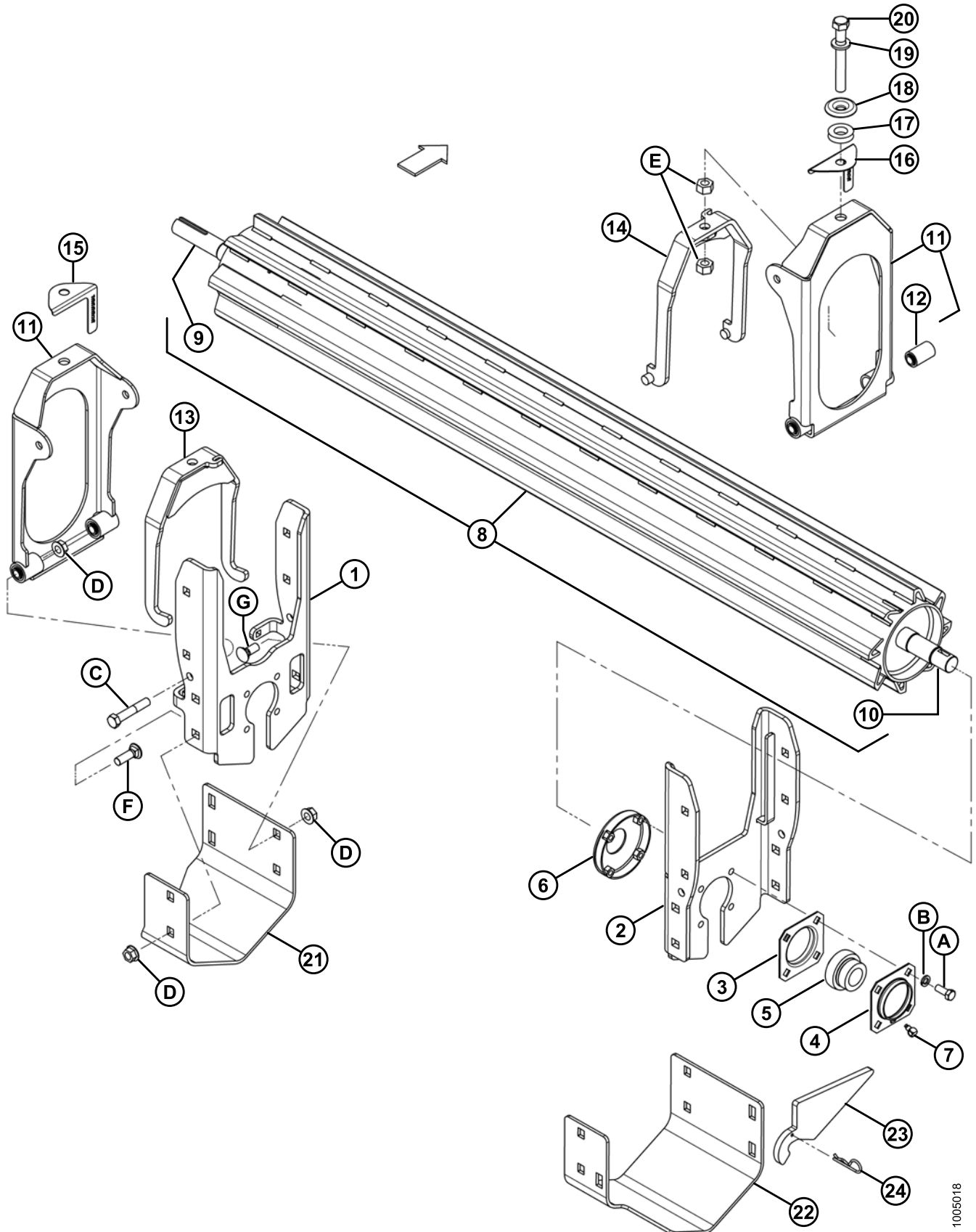

REPAIR PARTS

Ref	Part Number	Description	Qty	Serial Number
1	159117	SUPPORT – LH	1	
2	159118	FRAME – RH LOWER WELDT	1	
3	30576	FLANGE	2	
4	50182	FLANGE	2	
5	30031	BEARING – SPH OD C/W COLLAR 1.5 IN BORE	2	
6	101173	DISC WELDT	2	
7	50187	FITTING – LUBE 90° ADAPTER ⁹	2	
8	130445	ROLL – LOWER WELDT	1	
9	130704	SHAFT SPINDLE – LH LOWER ROLL (WELDED)	1	
10	130449	SHAFT SPINDLE – RH LOWER ROLL (WELDED)	1	
11	130476	CHANNEL – PIVOT C/W BUSHINGS	2	
12	13626	BUSHING – RUBBER	4	
13	130443	BRACKET – LH ADJUSTER WELDT	1	
14	130336	BRACKET – RH ADJUSTER WELDT	1	
15	130990	GAUGE – LH ROLL OPENING	1	
16	130994	GAUGE – RH ROLL OPENING	1	
17	47124	WASHER – RUBBER	2	
18	130532	WASHER – FORMED	2	
19	21540	WASHER – HARDENED	2	
20	135405	BOLT – HEXHD (MIN THD) 3/4 NC X 6.0 LG GR 5 ZP	2	
21	159404	SKID – LH CONDITIONER	1	
22	159405	SKID – RH CONDITIONER	1	
23	159352	SUPPORT	1	
24	13125	PIN – HAIR	1	
A	21491	BOLT – HEXHD 1/2 NC X 1.25 LG GR 5 ZP		
B	18638	WASHER – REG. LOCK 1/2 IN. NOM. I.D. ZP		
C	21406	BOLT – HEXHD 5/8 NC X 3.5 GR 5 ZP		
D	50225	NUT – FLANGE DT SMOOTH FACE .625-11 UNC		
E	18593	NUT – HEX 3/4-10 UNC GR 5 ZP		
F	18524	BOLT – RHSN, 5/8 NC x 2.0 LG GR 5 ZP		
G	18523	BOLT – RHSN, 5/8 NC x 1.5 LG GR 5 ZP		

9. Refer to Section [6.4 Cover and Supports](#), page 112, for lube lines.

6.3 Upper Roll Assembly

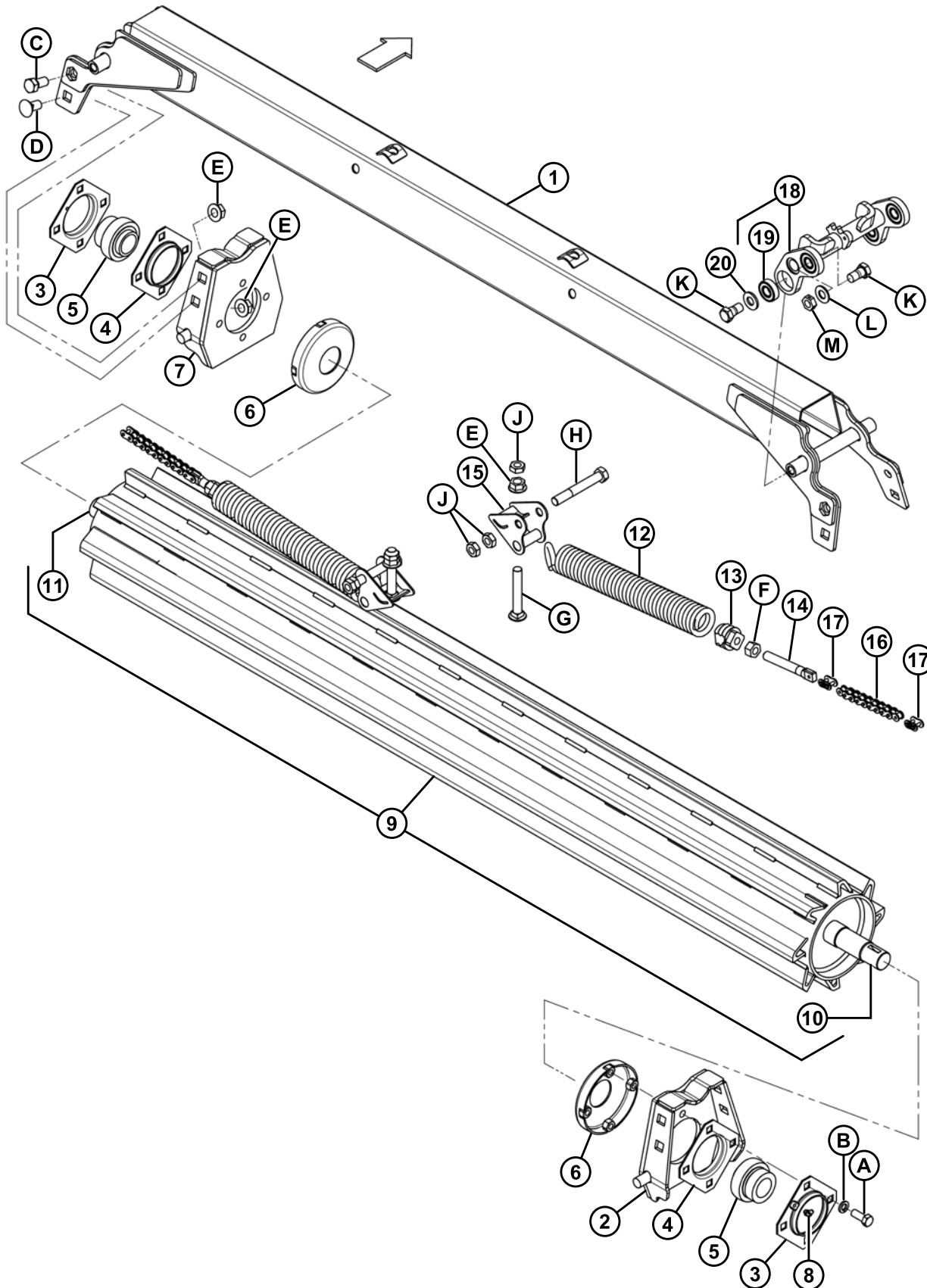

REPAIR PARTS

Ref	Part Number	Description	Qty	Serial Number
1	130470	CHANNEL – CROSS WELDT	1	
2	130793	SUPPORT – RH WELDT	1	
3	50182	FLANGE	2	
4	30576	FLANGE	2	
5	30031	BEARING – SPH OD C/W COLLAR 1.5 IN. BORE	2	
6	101173	DISC WELDT	2	
7	130472	SUPPORT – LH WELDT	1	
8	21301	FITTING – LUBRICATION	2	
9	159187	ROLL – UPPER WELDMENT	1	
10	130449	SPINDLE – RH (WELDED)	1	
11	170332	SHAFT – STUB, LH (WELDED)	1	
12	130744	SPRING	2	
13	34019	INSERT – MACH	2	
14	130527	STUD – THREADED	2	
15	130747	LEVER WELDT	2	
16	130645	CHAIN – #50 WO CONN (9 PITCHES)	2	
17	6634	LINK – CONNECTOR #50	4	
18	130450	TOGGLE ASSEMBLY C/W BEARINGS	2	
19	50185	BEARING – BALL CYL OD 17MM BORE	8	
20	30441	WASHER – HARDENED	4	
A	21491	BOLT – HEXHD 1/2 NC X 1.25 LG GR 5 ZP		
B	18638	WASHER – REG. LOCK 1/2 IN. NOM. I.D. ZP		
C	21585	BOLT – HEXHD 5/8 NC X 1.25 LG GR 5 ZP		
D	103562	BOLT – RHSN 5/8 NC X 1.25 GR 5 ZP		
E	50225	NUT – FLG DT SMTH FACE .625-11 UNC		
F	18592	NUT – HEX 5/8-11 UNC GR 5 ZP		
G	102658	BOLT – RHSN 5/8 NC X 4 TFL GR 5 ZP		
H	21720	BOLT – HEXHD 5/8 NC X 4.5 LG GR5 ZP		
J	21941	NUT – HEX LOCK JAM (DT) 5/8-11 UNC GR 5 ZP		
K	105141	BOLT – LOCKING SHOULDER		
L	18600	WASHER – SAE FLAT, 21/32 I.D. X 1-5/16 O.D. ZP		
M	105173	NUT – HEX JAM, CENTER LOCK		

6.4 Cover and Supports

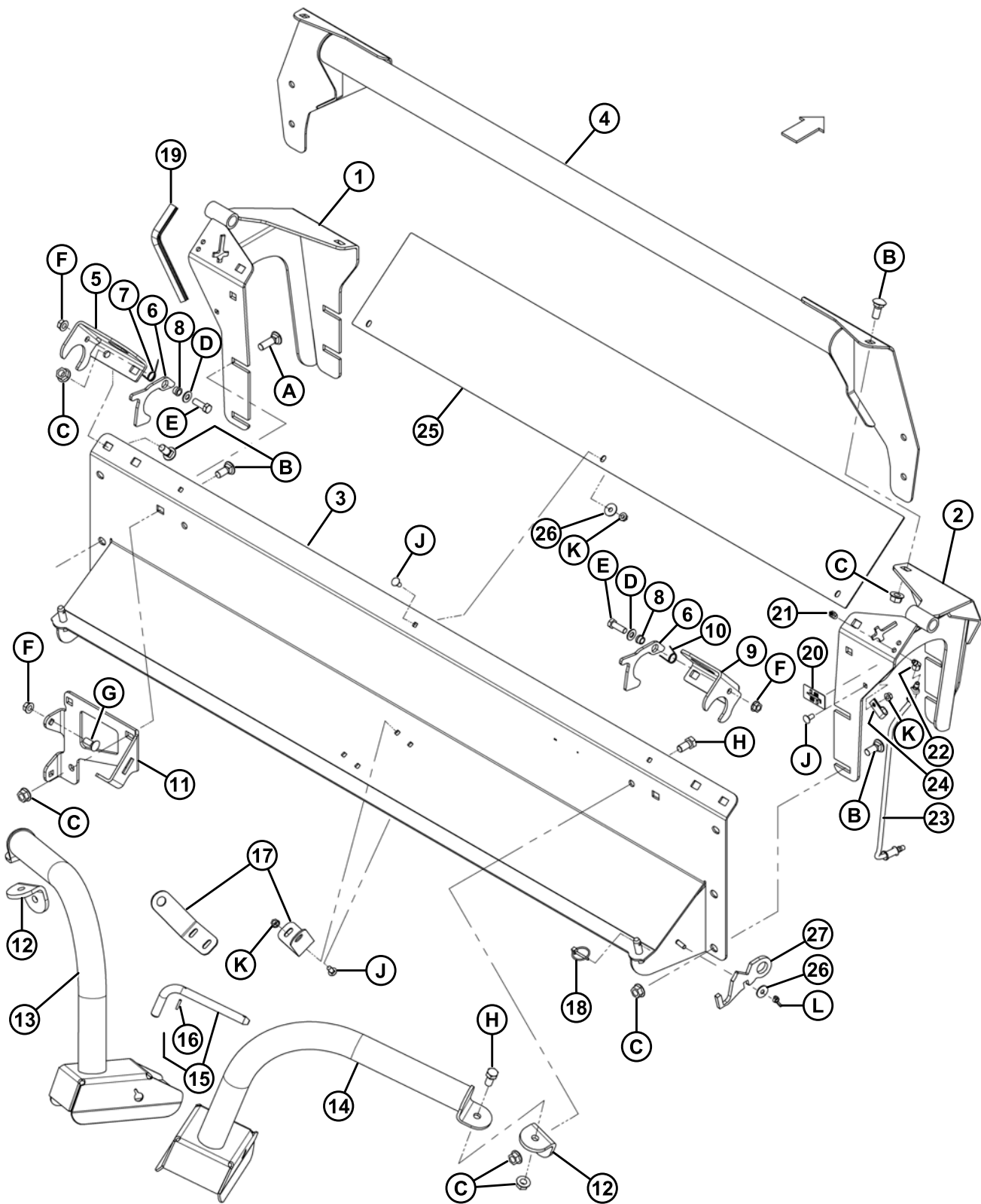

REPAIR PARTS

Ref	Part Number	Description	Qty	Serial Number
1	159231	SUPPORT WELDT – LH	1	
2	159582	SUPPORT WELDT – RH	1	
3	159200	COVER – TOP REAR WELDT	1	
4	130496	TUBE – CROSS WELDT	1	
5	159003	LATCH – WELDT, LH	1	
6	159001	LATCH	2	
7	159020	SPRING – TORSION	1	
8	159005	SPACER – 3/4 IN. O.D. X .120 WALL X 12 LONG ¹⁰	2	
9	159007	LATCH – WELDT, RH	1	
10	144505	SPRING – TORSION	1	
11	130757	SUPPORT – HYD MOTOR	1	
12	130858	ANGLE	2	
13	159329	SUPPORT – WELDT, LIFT ARM, LH	1	
14	159333	SUPPORT – WELDT, LIFT ARM, RH	1	
15	144415	ASSY – L-PIN ¹¹	2	
16	16010	PIN – SPRING 3/16 DIA X 1.0 LG	2	
17	159002	ANGLE	2	
18	102264	PIN – LYNCH 3/16 X 1-9/16 IN.	2	
19	110737	MOULDING – FRAME (UNIGRIP)	1	
20	23165	DECAL – 50 HR LUBE	2	
21	50188	FITTING – LUBRICATION 1/8 NPT FEMALE	2	
22	115677	FITTING – ELBOW 45° HYD	2	
23	159583	HOSE – GREASE, 1/8 IN. NPT	2	
24	135232	CLAMP – DOUBLE HOSE INSULATED	2	
25	156815	COVER – POLY	1	
26	19685	WASHER – FLAT	4	
27	150572	PLATE – ROLL TIMING GAUGE	1	

NOTE:

For hardware, refer to next page.

10. Stepped.

11. Includes item #16 (MD #16010), spring pin.

REPAIR PARTS

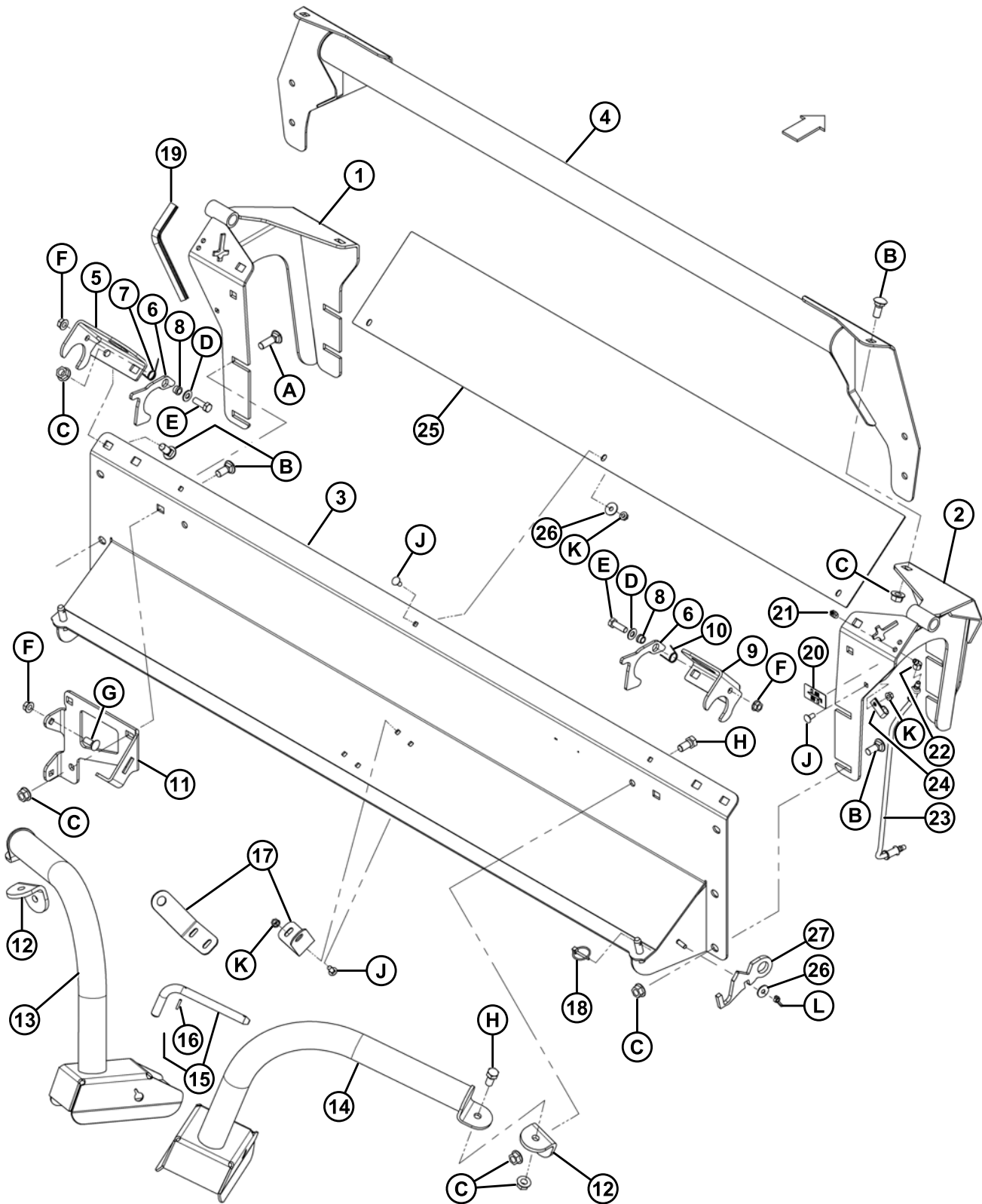

REPAIR PARTS

Ref	Part Number	Description	Qty	Serial Number
A	18524	BOLT – RHSN 5/8 NC X 2.0 LG GR 5 ZP		
B	18523	BOLT – RHSN 5/8 NC X 1.5 GR 5 ZP		
C	50225	NUT – FLG DT SMTH FACE .625-11 UNC		
D	18599	WASHER – SAE FLAT 17/32 I.D. X 1-1/16 IN. O.D. ZP		
E	18723	BOLT – HEXHD 1/2 NC X 1.5 LG TFL GR 5 ZP		
F	50186	NUT – FLG LK SMTH FACE DT .500-13 UNC GR 5		
G	21471	BOLT – RHSN 1/2 NC X 1.25 GR 5 ZP		
H	21585	BOLT – HEXHD 5/8 NC X 1.25 LG GR5 ZP		
J	21863	BOLT – RHSSN 3/8 NC X 0.75 LG GR 5 ZP		
K	30228	NUT – FLG DT SMTH FACE .375-16 UNC		
L	21289	NUT – ING TYPE A 3/8 NC ZP		

6.5 Hydraulic Motor, Mounts, and Tensioner

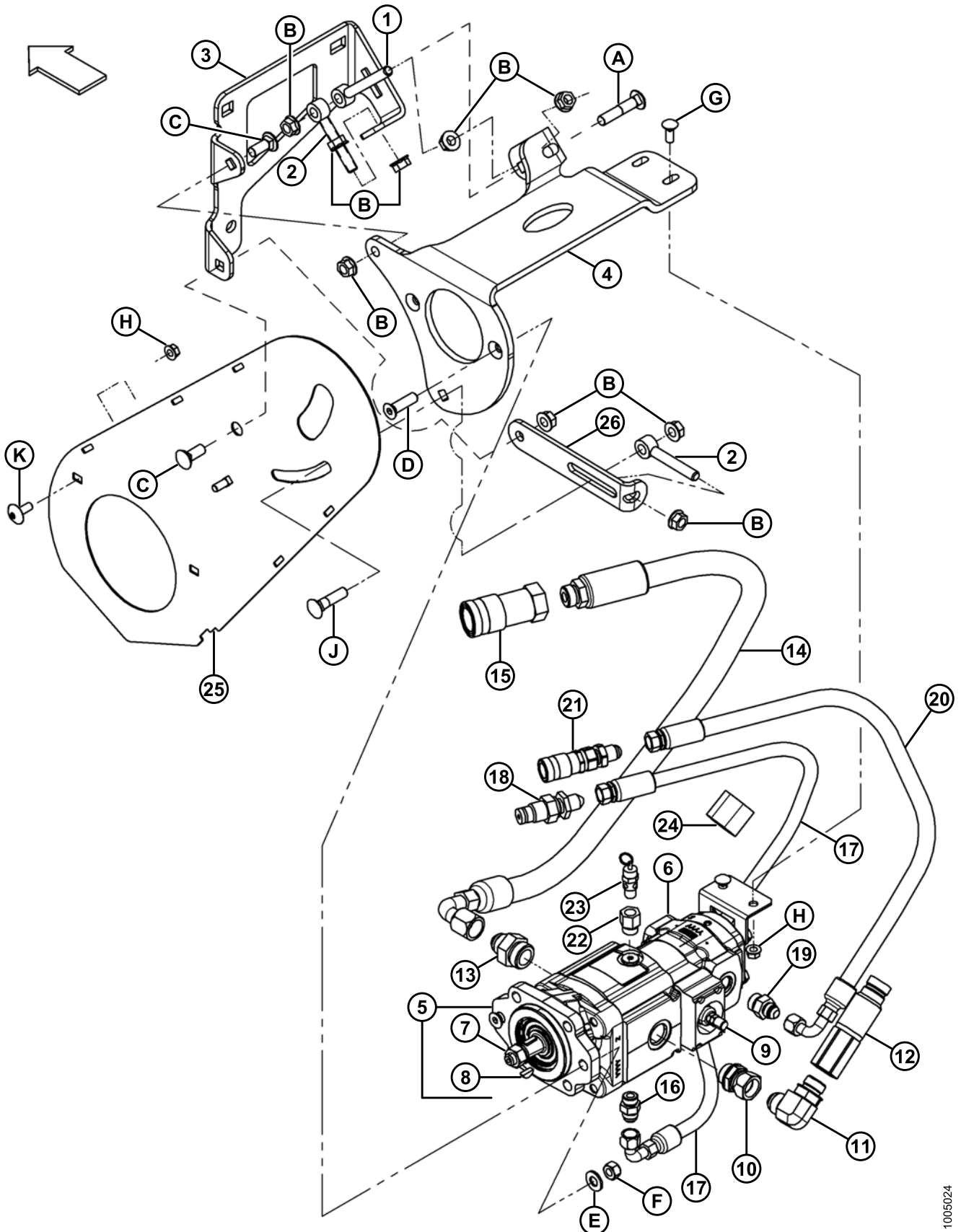

REPAIR PARTS

Ref	Part Number	Description	Qty	Serial Number
1	159452	BOLT WELDT – EYE	1	
2	130765	BOLT WELDT – EYE	2	
3	130757	SUPPORT – HYD MOTOR	1	
4	133965	SUPPORT – CASSAPA MOTOR	1	
5	159648	MOTOR – HYD FLOW DIVIDER (INCLUDES ITEMS #6–9)	1	
	159631	SEAL KIT (FOR MOTOR)		
6	159645	MOTOR – HYD, GEAR (CAST IRON BODY) ¹²		
	159649	MOTOR – HYD, GEAR (ALUMINUM BODY) ¹³		
7	159633	NUT – 8MM, SPECIAL		
8	159535	KEY – WOODRUFF (1/4 X 3/4 NOM.)	1	
9	159632	VALVE – RELIEF	1	
10	40241	FITTING – ADAPTER HYD C/W O-RING	1	
11	30970	FITTING – ELBOW 90° HYD	1	
12	135314	COUPLER – MALE HYD 3/4 IN. FLAT FACE	1	
	135479	SEAL KIT – 3/4 MALE COUPLER		
13	135483	FITTING – ADAPTER HYD	1	
14	159029	HOSE	1	
15	135565	COUPLER – FEMALE HYD 3/4 IN. FLAT FACE	1	
	111977	SEAL KIT – 3/4 FEMALE COUPLER		
16	21030	FITTING – CONNECTOR HYD, SAE 8 ¹⁴	1	
17	159646	HOSE ¹⁴	1	
18	135237	COUPLER – MALE HYD 3/8 IN. FLAT FACE BULKHEAD	1	
	111978	SEAL KIT – 3/8 MALE COUPLER		
19	21881	FITTING – ADAPTER HYD	1	
20	159028	HOSE	1	
21	135213	COUPLER – FEMALE HYD 3/8 FLAT FACE BULKHEAD	1	
	135481	SEAL KIT – 3/8 FEMALE COUPLER		
22	159419	FITTING – ADAPTER HYD C/W O-RING	1	
23	159635	VALVE – RELIEF	1	
24	135444	FASTENER – CINCH STRAP 6 IN. LG	2	
25	159541	SHIELD WELD'T	1	
26	159634	BAR – TENSIONER	1	

12. Preferred motor.

13. Use only if motor MD #159645 is unavailable.

14. Order items #16 (MD #21030) and #17 (MD #159646) together to ensure thread match.

REPAIR PARTS

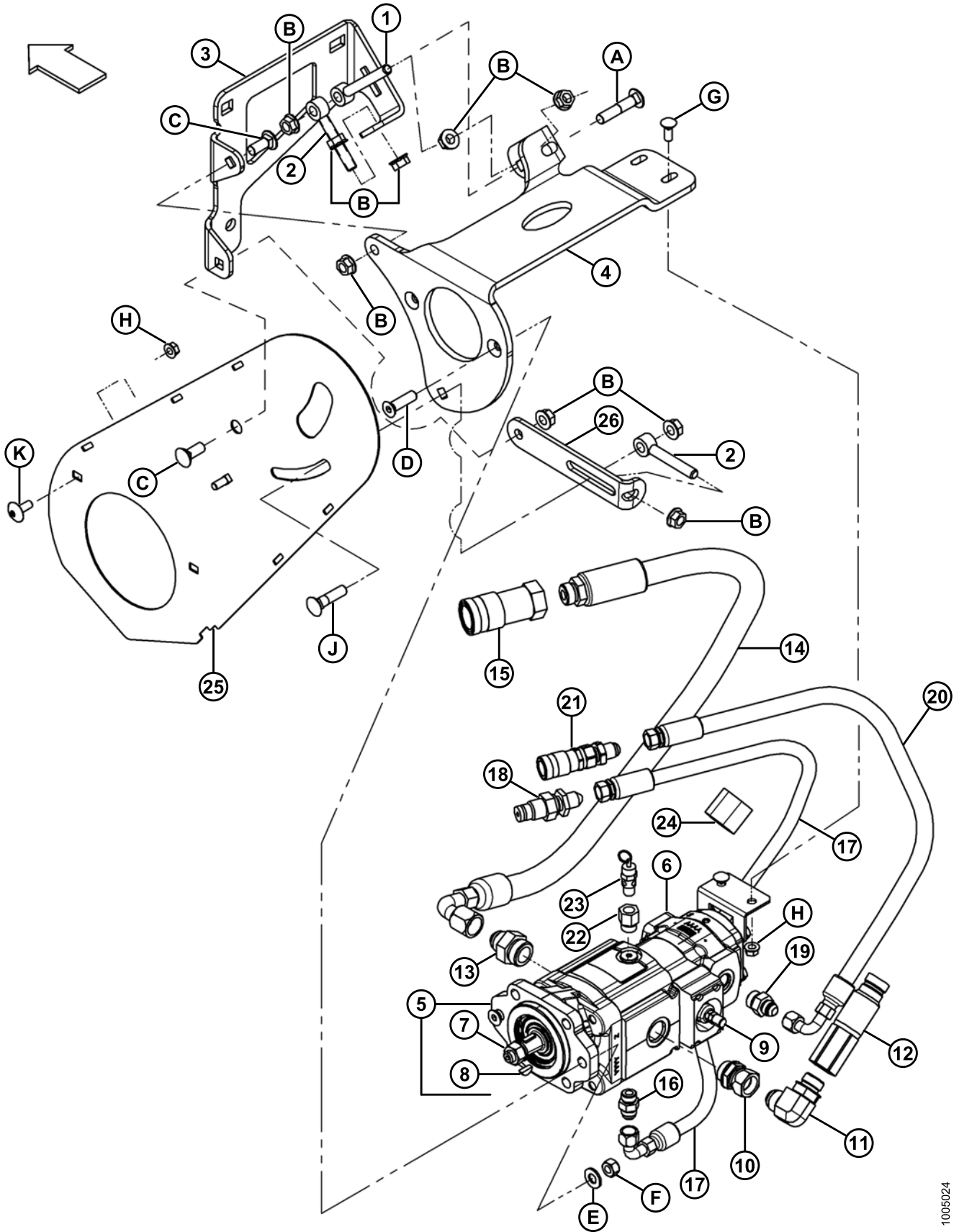

1005024

REPAIR PARTS

Ref	Part Number	Description	Qty	Serial Number
A	21489	BOLT – RHSN 1/2 NC X 2.5 LG GR 5 ZP		
B	50186	NUT – FLG LK SMTH FACE DT .500-13 UNC GR 5		
C	21471	BOLT – RHSN 1/2 NC X 1.25 GR 5 ZP		
D	137503	BOLT – CSK SOCK. 1/2 NC X 1.75 GR. 5 ZP		
E	18599	WASHER – SAE FLAT 17/32 I.D. X 1-1/16 IN. O.D. ZP		
F	18697	NUT – HEX LOCK DT .500-13 UNC		
G	19965	BOLT – RHSN 3/8 NC X 1.0 GR 5 ZP		
H	30228	NUT – FLG DT SMTH FACE .375-16 UNC		
J	21474	BOLT – RHSN 1/2 NC X 2.0 LG GR 5 ZP		
K	135507	SCREW – MACHINE, TRUSS HD TORX, 38 NC X 1 LG		

6.6 Belt Drive and Shield

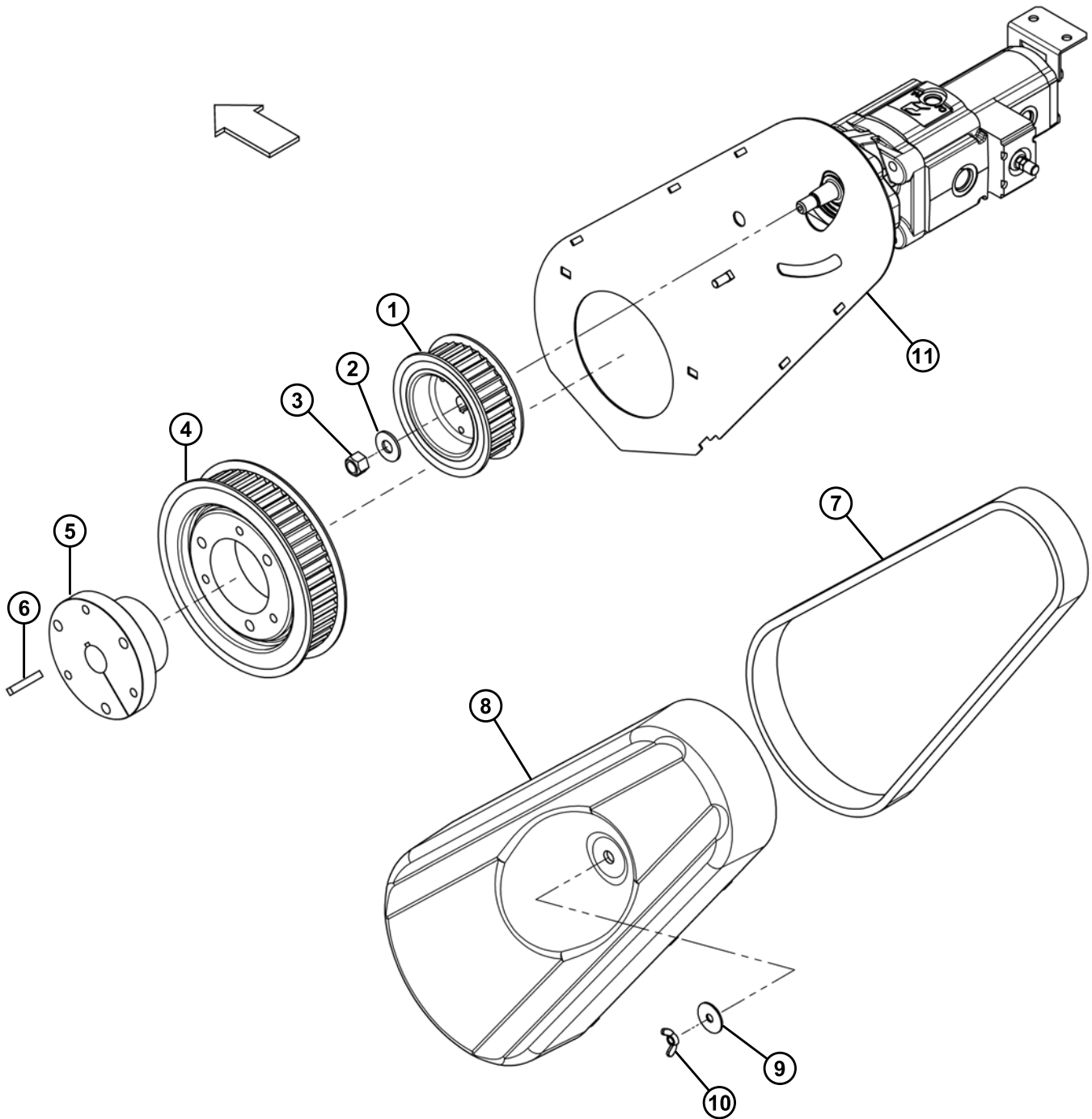

REPAIR PARTS

Ref	Part Number	Description	Qty	Serial Number
1	159430	SPROCKET – P32-14M-40	1	
2	1624	WASHER – SAE FLAT 5/8 I.D. X 1-15/32 IN. O.D. ZP	1	
3	18714	NUT – HEX LOCK DT 5/8-18 UNF ZP	1	
4	159215	SPROCKET – P52 14M 40	1	
5	130880	BUSHING – SPLIT TAPER QD-E-1.375 BORE	1	
6	17194	KEY	1	
7	130706	BELT – HTD 1610-14M-40	1	
8	159168	SHIELD – HT DRIVE	1	
9	14045	WASHER – FLAT	1	
10	21289	NUT – WING TYPE A 3/8 NC ZP	1	
11	REF	Refer to Section 6.5 Hydraulic Motor, Mounts, and Tensioner , page 116 .		

6.7 Hydraulic Completion Package

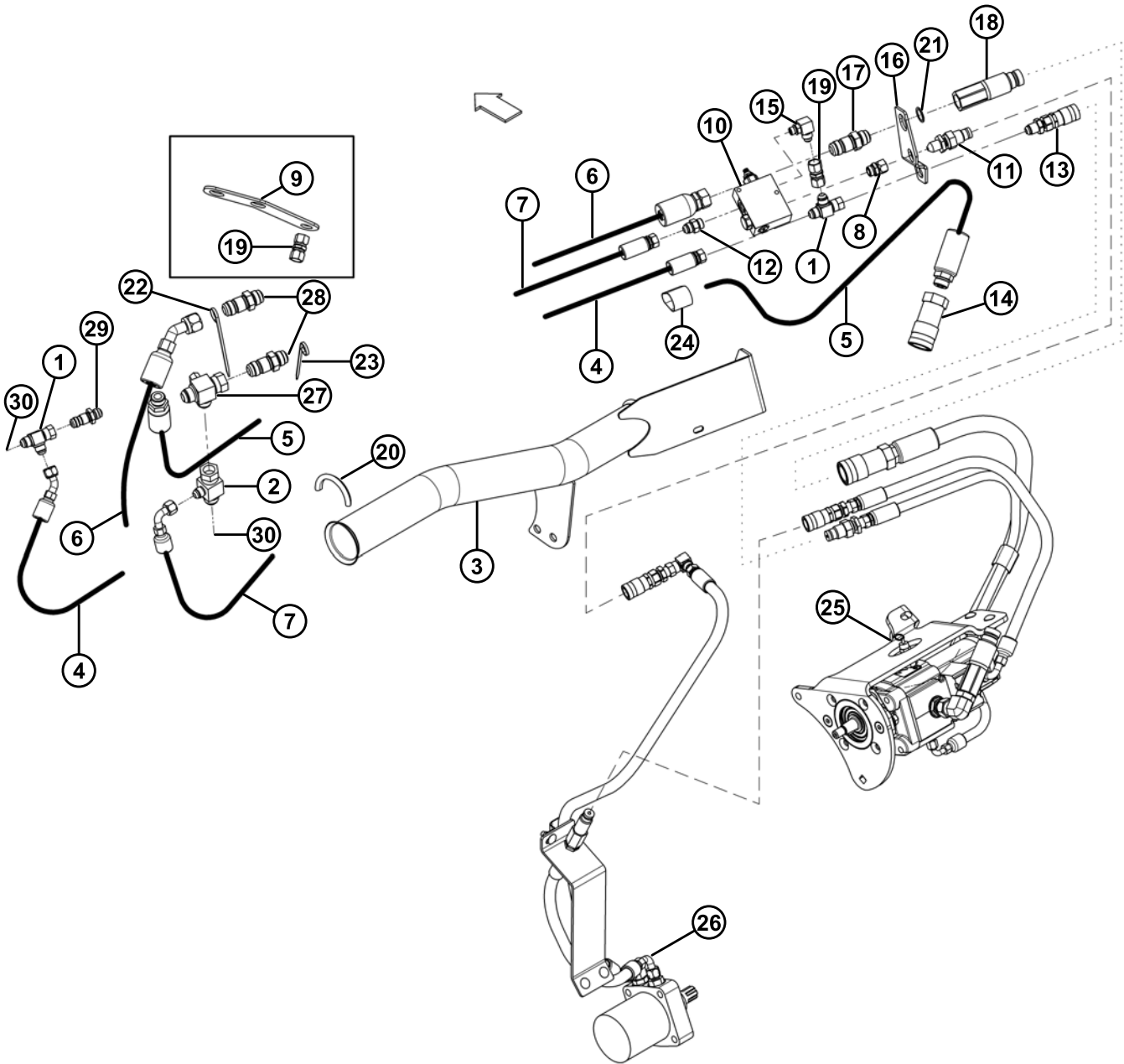

REPAIR PARTS

Ref	Part Number	Description	Qty	Serial Number
1	108268	FITTING – HYD TEE	2	
2	159038	VALVE – CHECK	1	
3	159158	HOLDER – HOSES	1	
4	159032	HOSE – HYDRAULIC, 1/2 IN. I.D.	1	
5	159030	HOSE – HYDRAULIC, 3/4 IN. I.D.	1	
6	120574	HOSE – HYDRAULIC, 3/4 IN. I.D.	1	
7	159159	HOSE – HYDRAULIC, 1/2 IN. I.D.	1	
8	135373	FITTING – ADAPTER HYD	1	
9	159358	SUPPORT – COUPLING (FOR 15 FT. HEADER ONLY)	1	
10	159417	VALVE – PRESSURE REDUCING	1	
11	135237	COUPLER – MALE HYD 3/8 IN. FLAT FACE BULKHEAD	1	
	111978	SEAL KIT – 3/8 MALE		
12	21030	FITTING – CONNECTOR HYD	1	
13	135213	COUPLING – FEMALE HYD 3/8 FLAT FACE BULKHEAD	1	
	135481	SEAL KIT – 3/8 FEMALE		
14	135565	COUPLER – FEMALE HYD 3/4 IN. FLAT FACE	1	
	111977	SEAL KIT – 3/4 FEMALE		
15	21805	FITTING – ELBOW HYD	1	
16	159421	PLATE	1	
17	135372	FTG – 3/4 IN. HYD BULKHEAD 37 DEG. FLAIR UNION	1	
18	135314	COUPLER – MALE HYD 3/4 IN. FLAT FACE	1	
	135479	SEAL KIT – 3/4 MALE		
19	135540	FITTING – FEMALE UNION HYD ¹⁵	1	
20	109791	MOULDING	1	
21	30971	O-RING	1	
22	40704	FASTENER – CABLE TIE (ORANGE)	2	
23	40703	FASTENER – CABLE TIE (BLUE)	1	
24	135444	FASTENER – CINCH STRAP 6 IN. LG	1	
25	REF	Refer to Section 6.5 Hydraulic Motor, Mounts, and Tensioner , page 116.		
26	REF	Refer to Section 6.10 Feed Deck and Pan , page 130.		
27	REF	FITTING – HYD TEE, SPECIAL ¹⁶	1	
28	REF	FITTING – 3/4 IN. HYD BULKHEAD 37 DEG. FLAIR UNION ¹⁶	2	

15. Quantity of two for 15-foot header.

16. Refer to header parts catalog for connecting parts.

REPAIR PARTS

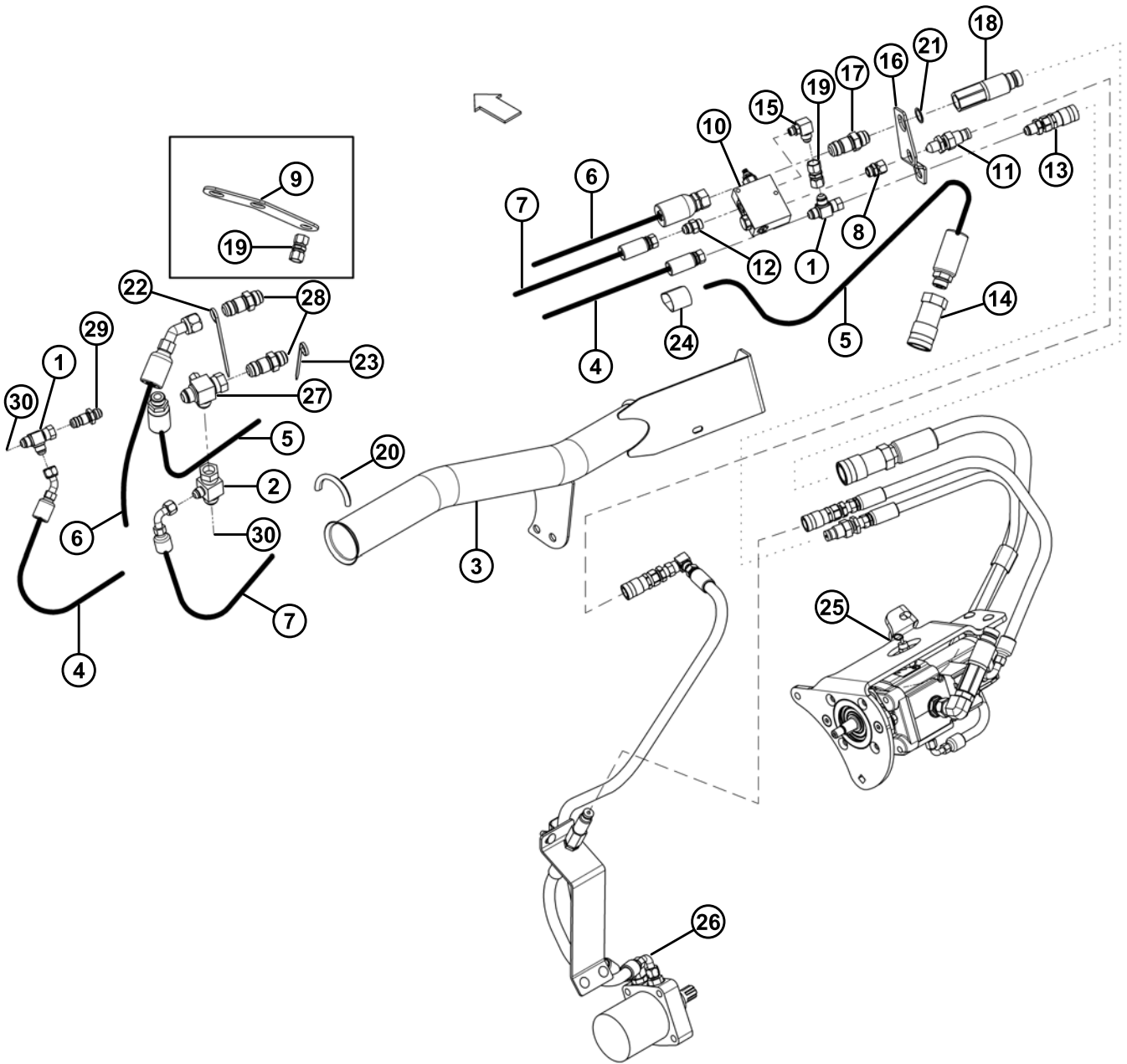

REPAIR PARTS

Ref	Part Number	Description	Qty	Serial Number
29	REF	FITTING – 1/2 IN. UNION HYDRAULIC ¹⁶	1	
30	REF	See note ¹⁶		

6.8 Gears and Roll Coupling Assembly

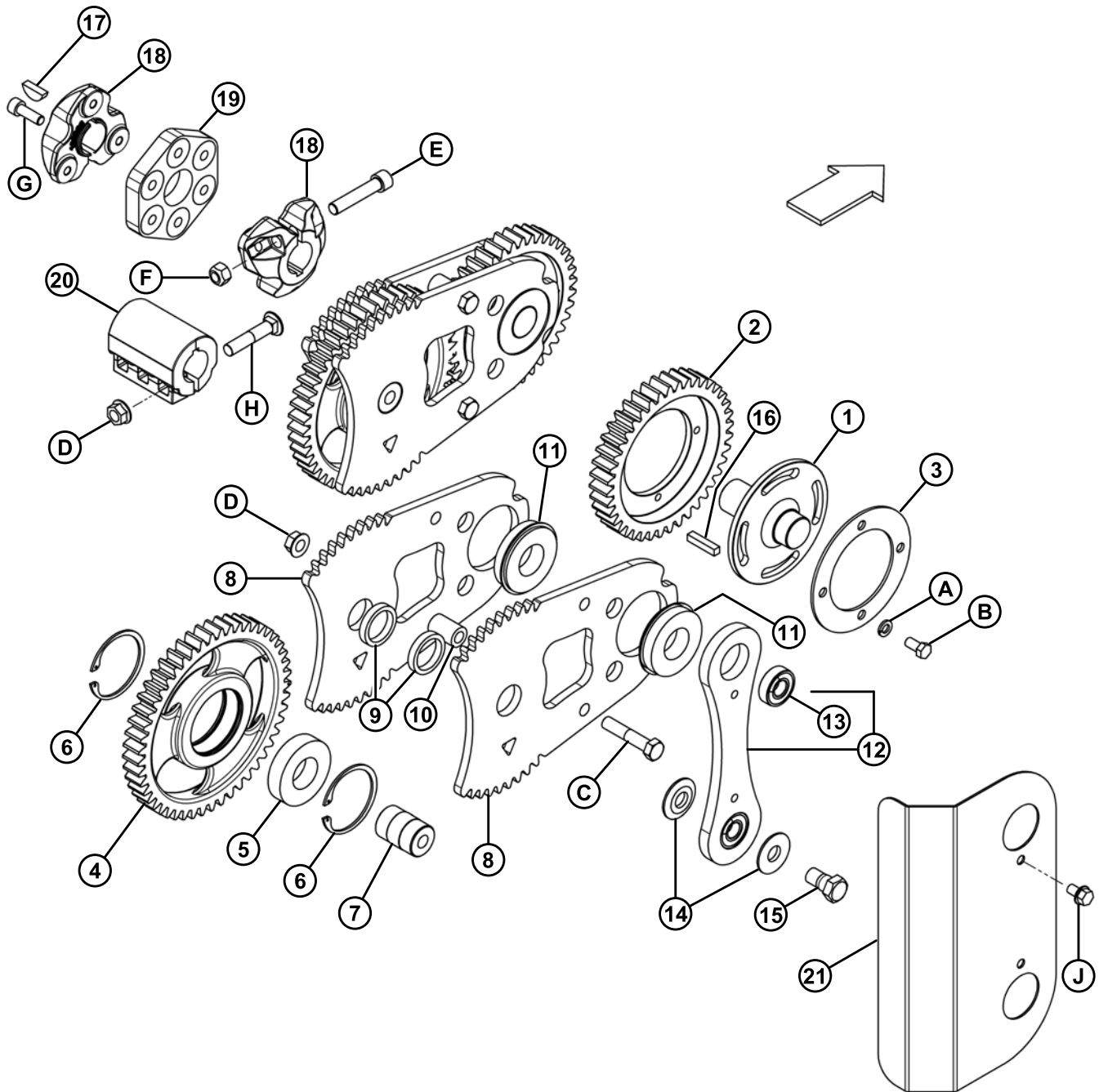

REPAIR PARTS

Ref	Part Number	Description	Qty	Serial Number
1	159550	HUB – MACHINING	2	
2	130680	GEAR – 40T	2	
3	129932	DISK	2	
4	130677	GEAR – 49T	2	
5	159474	BEARING – BALL CYL	2	
6	38854	RING – INT RETAINING	4	
7	130687	SHAFT – IDLER	2	
8	130685	PLATE, SIDE HEAT TREATMENT	4	
9	130689	SPACER	4	
10	130694	SPACER	4	
11	159478	BEARING – BALL CYL C3 WITH SNAP RING	4	
12	130691	SUB-ASSEMBLY – LINK	2	
13	50185	BEARING – BALL CYL OD 17 MM BORE	4	
14	130688	WASHER – MACHINED 11/16 I.D. X 1.75 IN. O.D. ZP	8	
15	105141	BOLT – LOCKING SHOULDER	4	
16	26846	KEY – HUB TO COUPLING	2	
17	11142	KEY – WOODRUFF (5/16 X 1-1/8 NOM.)	2	
18	130936	COUPLING-FLEX – MACHINING, UPPER ROLL	2	
19	130736	DISC – FLEX, UPPER ROLL	1	
20	159130	COUPLING – MACHINING, LOWER ROLL	1	
21	159218	COVER	1	
A	18637	WASHER – REG. LOCK 3/8 IN. NOM. I.D. ZP		
B	21567	BOLT – HH .375-16 UNC X 0.75 LG		
C	21760	BOLT – HEXHD 1/2 NC X 2.5 LG GR 5 ZP		
D	50186	NUT – FLG LK SMTH FACE DT .500-13 UNC GR 5		
E	135403	BOLT – SKT HD 1/2 NC X 2.5 LG		
F	18697	NUT – HEX LOCK DT .500-13 UNC		
G	135401	BOLT – HEX SKT HD M10 X 1.5 X 30 LG ZP		
H	21489	BOLT – RHSN 1/2 NC X 2.5 LG GR 5 ZP		
J	101898	SCREW – HEX WASH HD THD ROLLING 3/8 NC X 5/8		

6.9 Forming Shields

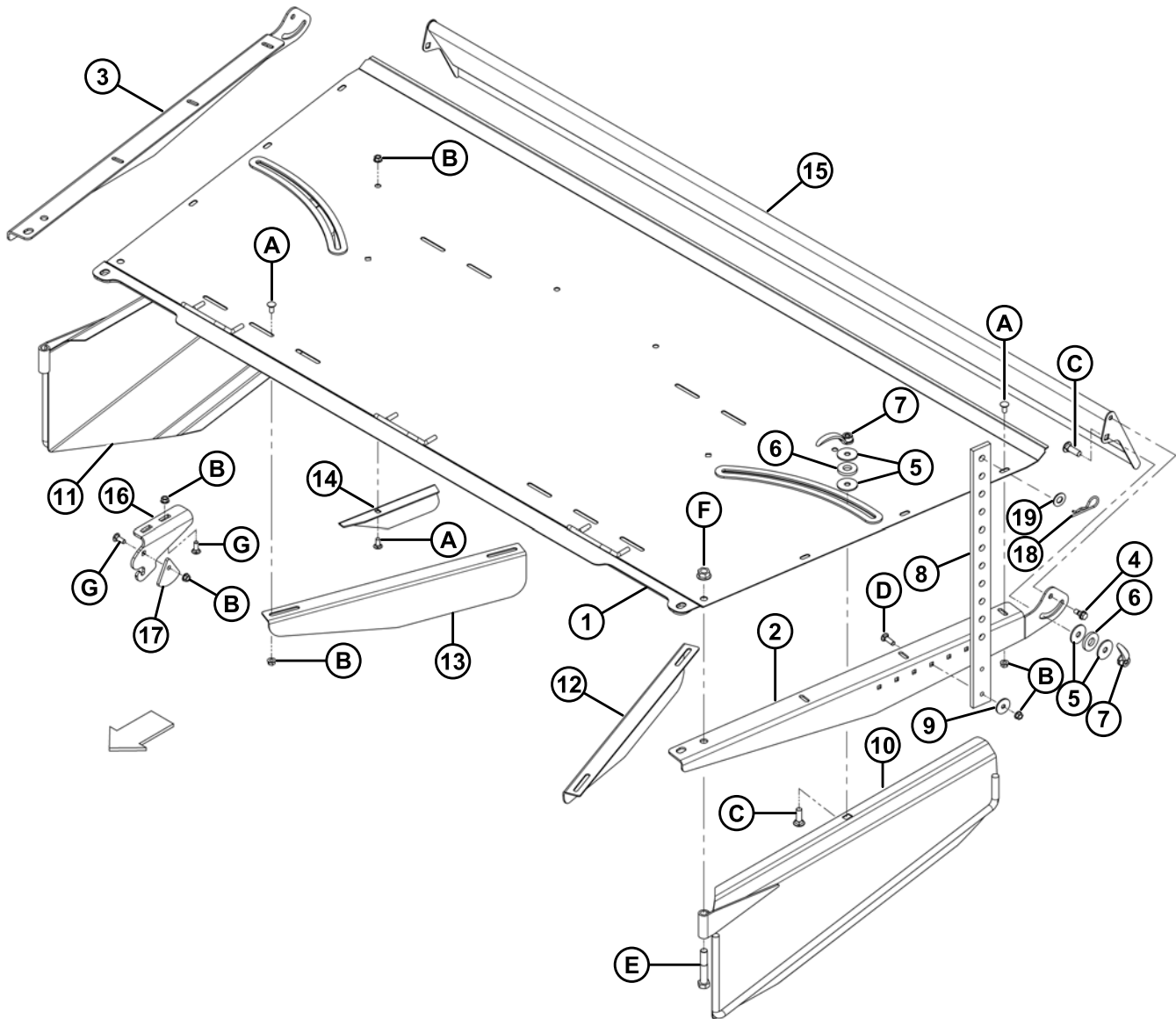

REPAIR PARTS

Ref	Part Number	Description	Qty	Serial Number
1	159204	COVER WELDT	1	
2	159206	SUPPORT – STRUT LH	1	
3	159207	SUPPORT – STRUT RH	1	
4	135001	BOLT – SHOULDER .375-16 UNC	2	
5	42592	WASHER – FLAT	8	
6	42045	WASHER – RUBBER	4	
7	149317	HANDLE	4	
8	159294	STRAP – RUBBER	2	
9	16652	WASHER – FLAT	2	
10	159220	DEFLECTOR WELDT, LH	1	
11	130911	DEFLECTOR WELDT, RH	1	
12	130905	DEFLECTOR – FIN, LH	1	
13	130906	DEFLECTOR – FIN, RH	1	
14	130548	DEFLECTOR – FIN	4	
15	130900	BAFFLE	1	
16	159598	SUPPORT – HANGER (TRACTOR MOUNTED)	1	
17	159325	SUPPORT – KEEPER	1	
18	13125	PIN – HAIR	2	
19	18600	WASHER – FLAT, 21/32 I,D, X 1-5/16 IN. O.D. ZP	2	
A	21863	BOLT – RHSSN 3/8 NC X 0.75 LG GR 5 ZP		
B	30228	NUT – FLANGE DT SMOOTH FACE .375-16 UNC		
C	21469	BOLT – RHSN 1/2 NC X 1.5 LG GR 5 ZP		
D	19966	BOLT – RHSN 3/8 NC X 1.25 LG GR 5 ZP		
E	21406	BOLT – HEXHD 5/8 NC X 3.5 GR 5 ZP		
F	50225	NUT – FLANGE DT SMOOTH FACE .625-11 UNC		
G	19965	BOLT – RHSN 3/8 NC X 1.0 GR 5 ZP		

6.10 Feed Deck and Pan

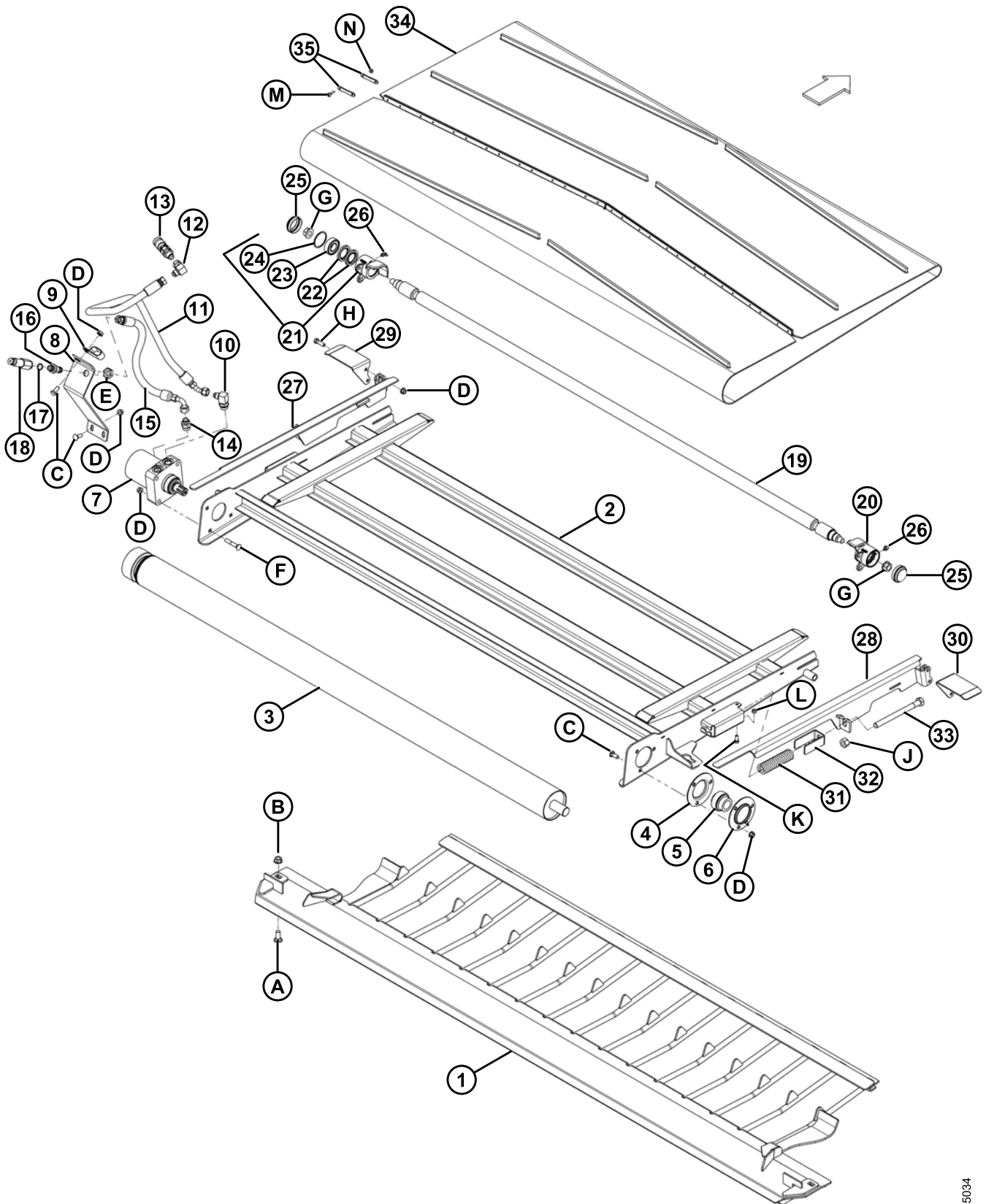

REPAIR PARTS

Ref	Part Number	Description	Qty	Serial Number
1	159432	PAN – FINGER FEED WELDT	1	
2	159399	FRAME, FEED DECK – WELDT	1	
3	133838	ROLLER – DRIVE 4 IN., WELDT	1	
4	49306	FLANGE	1	
5	21859	BEARING – SPH O.D. EXT INNER RACE 1-3/16 BORE	1	
6	30661	FLANGE	1	
7	159197	MOTOR – HYD 4.0 CID (WITH 921 PSI RELIEF)	1	
	37181	SEAL KIT – FOR MOTOR MD #159197		
	159606	VALVE – RELIEF, 921 PSI		
8	159183	HOLDER – COUPLING	1	
9	103738	CLAMP – PVC INSULATED 13/16 IN. TUBE SIZE	1	
10	21801	FITTING – ELBOW 90° HYD	1	
11	130998	HOSE	1	
12	30314	FITTING – ELBOW 90° HYD	1	
13	135213	COUPLING – FEMALE HYD 3/8 FLAT FACE BULKHEAD	1	
	135481	SEAL KIT – FOR 3/8 FEMALE COUPLER		
14	21881	FITTING – ADAPTER HYD	1	
15	159422	HOSE	1	
16	30819	FTG – 1/2 IN. HYD UNION	1	
17	44209	O-RING	1	
18	135386	COUPLER – MALE HYD 3/8 IN. FLAT FACE	1	
	111978	SEAL KIT – FOR 3/8 MALE COUPLER		
19	159256	SHAFT – IDLER ROLLER	1	
20	133124	HOUSING ASSY – RH IDLER CUP ¹⁷	1	
21	133126	HOUSING ASSY – LH IDLER CUP ¹⁷	1	
22	100862	SEAL – OIL	4	
23	118185	BEARING – BALL CYL, 52MM O.D., 25MM I.D.	2	
24	118011	RING – RETAINING, INTERNAL	2	
25	133372	CAP, DUST	2	
26	21010	FTG – LUBE 90 DEG 1/4-28 TAPER THD	2	
27	159383	SUPPORT WELDT – LH	1	
28	159385	SUPPORT WELDT – RH	1	
29	159260	GUIDE – LH	1	

17. Includes items #22–24.

REPAIR PARTS

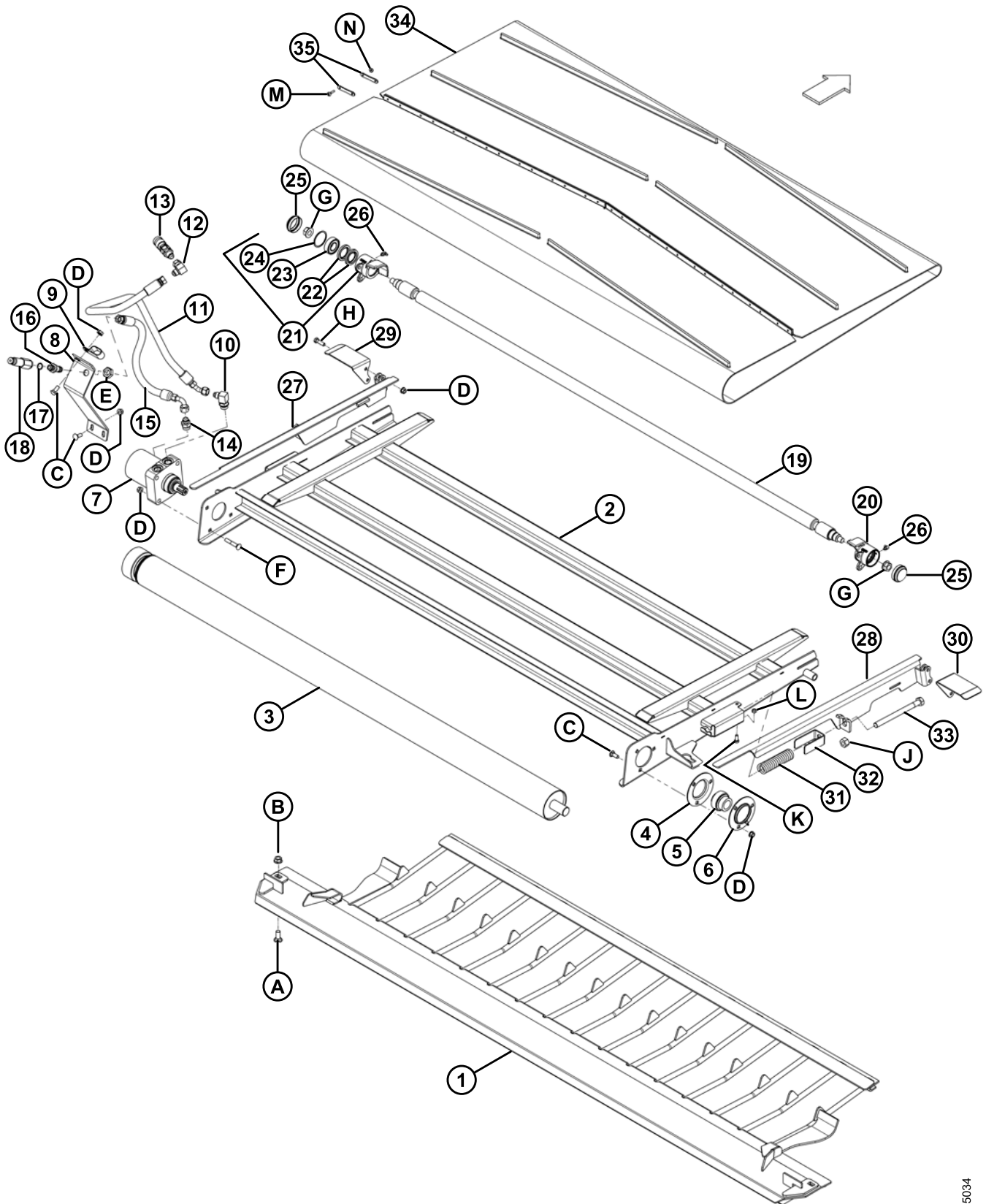

1005034

REPAIR PARTS

Ref	Part Number	Description	Qty	Serial Number
30	159264	GUIDE – RH	1	
31	133946	SPRING – COMPRESSION	2	
32	130246	RETAINER – SPRING	2	
33	50190	BOLT – HEXHD (MIN THD) 5/8 NC X 7.5 LG GR 5 ZP	2	
34	159393	DRAPER – 1850 WIDE X 2107 LONG	1	
35	130283	STRAP – DRAPER CONN	28	
A	21471	BOLT – RHSN 1/2 NC X 1.25 GR 5 ZP		
B	50186	NUT – FLG LK SMTH FACE DT .500-13 UNC GR 5		
C	19965	BOLT – RHSN 3/8 NC X 1.0 GR 5 ZP		
D	30228	NUT – FLG DT SMTH FACE 0.375-16 UNC		
E	7674	NUT – HEX JAM 3/4-16 UNF GR 5 ZP		
F	21485	BOLT – RHSN 3/8 NC X 2.25 LG GR 5 ZP		
G	50225	NUT – FLG DT SMTH FACE .625-11 UNC		
H	21264	BOLT – HEXHD 3/8 NC X 1.25 LG GR 5 ZP		
J	18592	NUT – HEX 5/8-11 UNC GR 5 ZP		
K	21558	BOLT – HEXHD 5/16 NC X 0.75 LG GR 5 ZP		
L	18690	NUT – HEX LOCK DT 5/16-18 UNC ZP		
M	49671	SCREW – BT HD RIB NK, #12-24 NC X 0.920 IN. LG		
N	30669	NUT – CSK CENTER LOCK #12-24 NC		

6.11 Mounting Brackets

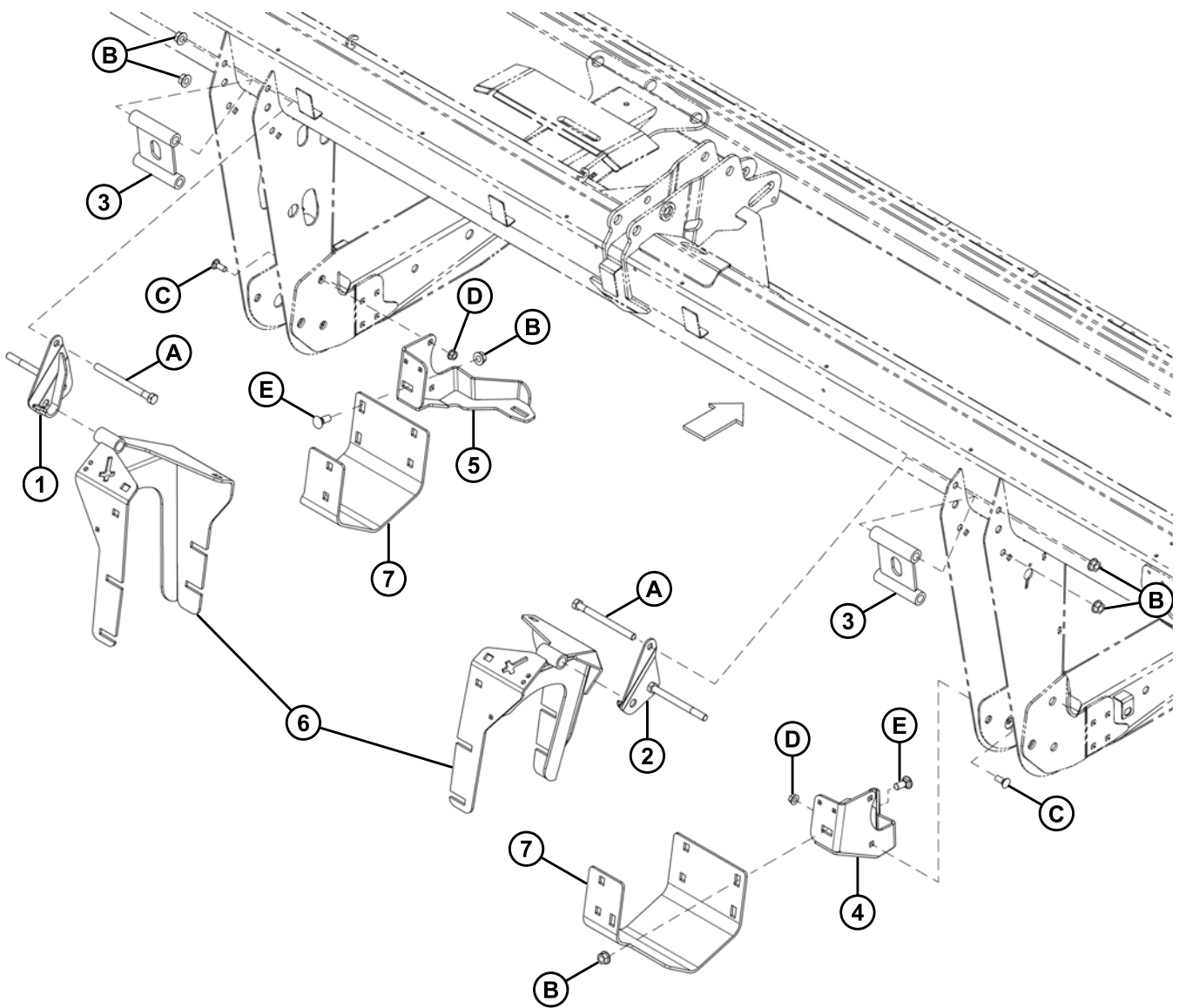

REPAIR PARTS

Ref	Part Number	Description	Qty	Serial Number
1	130802	SUPPORT – LH WELDT	1	
2	130803	SUPPORT – RH WELDT	1	
3	159590	SPACER BRACKET	2	
4	130831	SUPPORT – RH WELDT	1	
5	130817	SUPPORT – LH WELDT	1	
6	REF	Refer to Section 6.4 Cover and Supports, page 112.		
7	REF	Refer to Section 6.2 Lower Roll and Frame Assembly, page 108.		
A	50190	BOLT – HEXHD (MIN THD) 5/8 NC X 7.5 LG GR 5 ZP		
B	50225	NUT – FLG DT SMTH FACE .625-11 UNC		
C	21471	BOLT – RHSN 1/2 NC X 1.25 GR 5 ZP		
D	50186	NUT – FLG LK SMTH FACE DT .500-13 UNC GR 5		
E	18523	BOLT – RHSN 5/8 NC X 1.5 GR 5 ZP		

Index

1624	121
6634	111
7674	133
11142	127
13125	129
14045	121
16010	113
16652	129
17194	121
18523	109, 115, 135
18524	109, 115
18592	111, 133
18593	109
18599	115, 119
18600	111, 129
18637	127
18638	109, 111
18690	133
18697	119, 127
18714	121
18723	115
19685	113
19965	119, 129, 133
19966	129
21010	131
21030	117, 123
21264	133
21289	115, 121
21301	111
21406	109, 129
21469	129
21471	115, 119, 133, 135
21474	119
21485	133
21489	119, 127
21491	109, 111
21558	133
21567	127
21585	111, 115
21720	111
21760	127
21801	131
21805	123
21859	131
21863	115, 129
21881	117, 131
21941	111
23165	113
26846	127
30031	111
30228	115, 119, 129, 133
30314	131
30441	111
30576	111
30661	131
30669	133
30819	131
30970	117
30971	123
34019	111
37181	131
38854	127
40241	117
40703	123
40704	123
42045	129
42592	129
44209	131
49306	131
49671	133
50182	111
50185	111, 127
50186	115, 119, 127, 133, 135
50188	113
50190	133, 135
50225	109, 111, 115, 129, 133, 135
A	
API	
definition	9
ASTM	
definition	9
B	
belt drive	
parts	120
break-in period	79
C	
center-link	9
<i>See also</i> hydraulic link	
<i>See also</i> mechanical link	
definition	9
component identification diagram	25
conditioner	
installing using lifting method	37
installing using windrower method	39
operating	82

INDEX

running up	63
unplugging	87
conversion chart	24
cover	
parts	112

D

daily startup check	81
deck bracket	
installing	33
definition of terms	9
deflector fin	
adjusting	87
drive belt	
adjusting pulley alignment	97
adjusting tension	96
adjusting tracking	98
installing	100
removing	100
drive belt tension	
predelivery check	61
driveshield	
installing	91
parts	120
removing	91

F

feed deck	
detaching	76
installing	35
parts	130
feed draper	
adjusting tension	95
speed	82
feed pan	
parts	130
fluffer shield, See rear deflector	
forming shield	
adjusting deflector fins	87
adjusting height	86
adjusting rear deflector	87
adjusting side deflectors	86
assembling	52
description	85
installing	55
parts	128
frame assembly	
parts	108

G

gear

parts	126
glossary	9
greasing point	59, 93
greasing procedure	58, 92

H

hay conditioner	
attaching to header	67
components	25
detaching from header using lifting method	72
detaching from header using windrower	
method	68
installing using lifting method	37
installing using windrower method	39
unloading	29
header	
attaching hay conditioner	67
definition	9
detaching from hay conditioner using lifting	
method	72
detaching from hay conditioner using	
windrower method	68
preparing for installation of hay conditioner	31
hoses and lines	94
hydraulic fitting	
flare-type	16
O-ring boss (ORB) adjustable	18
O-ring boss (ORB) non-adjustable	20
O-ring face seal (ORFS)	21
hydraulic schematic	
header	50
hydraulics	94
attaching to 15-foot header	45
attaching to any header except 15-foot	47
completion package parts	122
hoses and lines	94
motor and mount parts	116
safety	6
schematics	94

L

lower roll	
parts	108
lubricant	92
lubrication	92
greasing procedure	58, 92
lubrication point	59, 93

M

maintenance	
preparing for servicing	89

INDEX

- preseason..... 80
- maintenance and servicing
 - conversion chart..... 24
 - maintenance safety 5
- manual..... 64
- metric bolt
 - torque..... 13
 - torque when bolting onto cast aluminum 16
- mounting bracket
 - parts..... 134

- O**
- operator responsibility 65
- owner responsibility 65

- P**
- predelivery check..... 61
 - manuals..... 64
- predelivery checks
 - checking roll drive belt tension..... 61
 - checking roll gap 62
 - checking roll timing..... 62
 - running up the conditioner..... 63
- preseason check 80

- R**
- rear deflector
 - adjusting..... 87
- rock grate
 - detaching..... 76
 - installing 32
- roll coupling assembly
 - parts..... 126
- roll gap
 - adjusting..... 82
 - predelivery check 62
- roll speed 82
- roll tension
 - adjusting..... 84
- roll timing
 - adjusting..... 83
 - checking 83
 - predelivery check 62
- rpm
 - definition 9

- S**
- SAE
 - bolt torque 11
 - definition 9

- safety
 - alert symbols..... 1
 - daily startup check..... 81
 - general safety 3
 - hydraulic safety 6
 - maintenance and servicing..... 5
 - operational..... 66
 - safety sign decals..... 7
 - installing..... 7
 - signal words..... 2
- schematic 94
- serial number iii
- side deflector
 - adjusting 86
- specification
 - HC10 model..... 23
 - torque specifications 11
- spm
 - definition 9
- startup
 - daily check..... 81
- storage 88
- support
 - parts..... 112

- T**
- tensioner
 - parts..... 116
- torque specification..... 11
 - flare-type hydraulic fitting 16
 - metric bolt..... 13
 - metric bolt bolting into cast aluminum 16
 - O-ring boss (ORB) hydraulic fitting
 - adjustable..... 18
 - non-adjustable 20
 - O-ring face seal (ORFS) hydraulic fitting 21
 - SAE bolt 11
- tractor
 - definition..... 9
- troubleshooting..... 104
- truck
 - definition..... 9

- U**
- upper roll assembly
 - parts..... 110

- W**
- windrower
 - attaching..... 57
 - shutting down..... 66

Model HC10 Hay Conditioner Predelivery Checklist

Perform these checks and adjustments prior to delivery to your Customer. Refer to Unloading and Assembly Instructions for adjustment details. The completed checklist should be retained either by the Operator or the Dealer.

CAUTION

Carefully follow the instructions given. Be alert for safety-related messages, which bring your attention to hazards and unsafe practices.

Conditioner Serial Number: _____

✓	Item	Reference
	Check for shipping damage or missing parts. Be sure all shipping dunnage is removed.	—
	Check roll drive belt tension.	3.13.1 Checking Roll Drive Belt Tension, page 61
	Check conditioner roll gap, timing, and alignment.	3.13.2 Checking Roll Gap, page 62 and 3.13.3 Checking Roll Timing, page 62
	Check rear and side forming shields evenly set to desired position.	3.10 Installing the Forming Shield, page 55
	Grease all bearings.	3.12 Lubricating the Conditioner, page 58
	Check roll intermesh hardware is securely tightened.	4.9.2 Adjusting Roll Gap, page 82
	Check hydraulic hose routing.	4.3 Attaching Hay Conditioner to Header, page 67
	RUN-UP PROCEDURE	3.13.4 Running Up the Conditioner, page 63
	Check reverse operating mode.	Refer to windrower manual.
	Check hydraulic hose routing for clearance when raising or lowering header.	—
	POST RUN-UP CHECKS. STOP ENGINE.	—
	Check for hydraulic leaks.	—
	Check belt drive for alignment and heated bearings.	5.7 Drive Belt, page 96
	Check manuals in windrower cab.	3.13.5 Storing Manuals, page 64

Date checked: _____

Checked by: _____

MacDon Industries Ltd.

680 Moray Street
Winnipeg, Manitoba
Canada R3J 3S3
t. (204) 885-5590
f. (204) 832-7749

MacDon, Inc.

10708 N. Pomona Avenue
Kansas City, Missouri
United States 64153-1924
t. (816) 891-7313
f. (816) 891-7323

MacDon Australia Pty. Ltd.

A.C.N. 079 393 721
P.O. Box 243, Suite 3, 143 Main Street
Greensborough, Victoria, Australia 3088
t. 03 9432 9982
f. 03 9432 9972

LLC MacDon Russia Ltd.

123317 Moscow, Russia
10 Presnenskaya nab, Block C
Floor 5, Office No. 534, Regus Business Centre
t. +7 495 775 6971
f. +7 495 967 7600

CUSTOMERS

MacDon.com

DEALERS

Portal.MacDon.com

Trademarks of products are the marks of their
respective manufacturers and/or distributors.

Printed in Canada