

M1240 Windrower

Operator's Manual

215357 Revision A

Original Instruction

This manual contains instructions for safety, operation, maintenance, and service for the MacDon M1240 Windrower, featuring Dual Direction® and CrossFlex™ rear suspension.



1016391

Published August 2020.

© 2020 MacDon Industries, Ltd.

The information in this publication is based on the information available and in effect at the time of printing. MacDon Industries, Ltd. makes no representation or warranty of any kind, whether expressed or implied, with respect to the information in this publication. MacDon Industries, Ltd. reserves the right to make changes at any time without notice.

California Proposition 65 Warning

Diesel engine exhaust and some of its constituents are known to the State of California to cause cancer, birth defects, and other reproductive harm. Battery posts, terminals, and related accessories contain lead and lead components. Wash hands after handling.

Declaration of Conformity



EC Declaration of Conformity

[1] **MacDon**

MacDon Industries Ltd.
680 Moray Street,
Winnipeg, Manitoba, Canada
R3J 3S3

[4] As Per Shipping Document

[5] May 14, 2020

[2] Windrower

[6] _____

[3] MacDon M1240

Christoph Martens
Product Integrity

EN	BG	CZ	DA
<p>We, [1] Declare, that the product: Machine Type: [2] Name & Model: [3] Serial Number(s): [4] fulfils all the relevant provisions of the Directive 2006/42/EC. Harmonized standards used, as referred to in Article 7(2): EN ISO 4254-1:2013 EN ISO 4254-7:2009 Place and date of declaration: [5] Identity and signature of the person empowered to draw up the declaration: [6] Name and address of the person authorized to compile the technical file: Benedikt von Riedesel General Manager, MacDon Europe GmbH Hagenauer Straße 59 65203 Wiesbaden (Germany) bvonriedesel@macdon.com</p>	<p>Ние, [1] декларираме, че следният продукт: Тип машина: [2] Наименование и модел: [3] Сериен номер(а) [4] отговаря на всички приложими разпоредби на директива 2006/42/ЕО. Исползвани са следните хармонизирани стандарти според чл. 7(2): EN ISO 4254-1:2013 EN ISO 4254-7:2009 Място и дата на декларацията: [5] Име и подпис на лицето, упълномощено да изготви декларацията: [6] Име и адрес на лицето, упълномощено да състави техническия файл: Бенедикт фон Рийдезел Управител, MacDon Europe GmbH Hagenauer Straße 59 65203 Wiesbaden (Германия) bvonriedesel@macdon.com</p>	<p>My, [1] Prohlašujeme, že produkt: Typ zařízení: [2] Název a model: [3] Sériové(á) číslo(a): [4] splňuje všechna relevantní ustanovení směrnice 2006/42/EC. Byly použity harmonizované standardy, jak je uvedeno v článku 7(2): EN ISO 4254-1:2013 EN ISO 4254-7:2009 Místo a datum prohlášení: [5] Identita a podpis osoby oprávněné k vydání prohlášení: [6] Jméno a adresa osoby oprávněné k vyplnění technického souboru: Benedikt von Riedesel generální ředitel, MacDon Europe GmbH Hagenauer Straße 59 65203 Wiesbaden (Německo) bvonriedesel@macdon.com</p>	<p>Vi, [1] erklærer, at produktet: Maskintype [2] Navn og model: [3] Serienummer (-numre): [4] Opfylder alle bestemmelser i direktiv 2006/42/EF. Anvendte harmoniserede standarder, som henviser til i paragraf 7(2): EN ISO 4254-1:2013 EN ISO 4254-7:2009 Sted og dato for erklæringen: [5] Identitet på og underskrift fra den person, som er bemyndiget til at udarbejde erklæringen: [6] Navn og adresse på den person, som er bemyndiget til at udarbejde den tekniske fil: Benedikt von Riedesel Direktør, MacDon Europe GmbH Hagenauer Straße 59 D-65203 Wiesbaden (Tyskland) bvonriedesel@macdon.com</p>

DE	ES	ET	FR
<p>Wir, [1] Erklären hiermit, dass das Produkt: Maschinentyp: [2] Name & Modell: [3] Seriennummer (n): [4] alle relevanten Vorschriften der Richtlinie 2006/42/EG erfüllt. Harmonisierte Standards wurden, wie in folgenden Artikeln angegeben, verwendet 7(2): EN ISO 4254-1:2013 EN ISO 4254-7:2009 Ort und Datum der Erklärung: [5] Name und Unterschrift der Person, die dazu befugt ist, die Erklärung auszustellen: [6] Name und Anschrift der Person, die dazu befugt ist, die technischen Unterlagen zu erstellen: Benedikt von Riedesel General Manager, MacDon Europe GmbH Hagenauer Straße 59 65203 Wiesbaden bvonriedesel@macdon.com</p>	<p>Nosotros [1] declaramos que el producto: Tipo de máquina: [2] Nombre y modelo: [3] Números de serie: [4] cumple con todas las disposiciones pertinentes de la directriz 2006/42/EC. Se utilizaron normas armonizadas, según lo dispuesto en el artículo 7(2): EN ISO 4254-1:2013 EN ISO 4254-7:2009 Lugar y fecha de la declaración: [5] Identidad y firma de la persona facultada para draw redactar la declaración: [6] Nombre y dirección de la persona autorizada para elaborar el expediente técnico: Benedikt von Riedesel Gerente general - MacDon Europe GmbH Hagenauer Straße 59 65203 Wiesbaden (Alemania) bvonriedesel@macdon.com</p>	<p>Meie, [1] deklareerime, et toode Seadme tüüp: [2] Nimi ja mudel: [3] Seerianumbrid: [4] vastab kõigile direktiivi 2006/42/EÜ asjakohastele sätetele. Kasutatud on järgnevald harmoniseeritud standardeid, millele on viidatud ka punktis 7(2): EN ISO 4254-1:2013 EN ISO 4254-7:2009 Deklaratsiooni koht ja kuupäev: [5] Deklaratsiooni koostamiseks volitatud isiku nimi ja allkiri: [6] Tehnilise dokumendi koostamiseks volitatud isiku nimi ja aadress: Benedikt von Riedesel Peadirektor, MacDon Europe GmbH Hagenauer Straße 59 65203 Wiesbaden (Saksamaa) bvonriedesel@macdon.com</p>	<p>Nous soussignés, [1] Déclarons que le produit : Type de machine : [2] Nom et modèle : [3] Numéro(s) de série : [4] Est conforme à toutes les dispositions pertinentes de la directive 2006/42/EC. Utilisation des normes harmonisées, comme indiqué dans l'Article 7(2): EN ISO 4254-1:2013 EN ISO 4254-7:2009 Lieu et date de la déclaration : [5] Identité et signature de la personne ayant reçu le pouvoir de rédiger cette déclaration : [6] Nom et adresse de la personne autorisée à constituer le dossier technique : Benedikt von Riedesel Directeur général, MacDon Europe GmbH Hagenauer Straße 59 65203 Wiesbaden (Allemagne) bvonriedesel@macdon.com</p>

The Harvesting Specialists

MacDon

1033471

EC Declaration of Conformity

IT	HU	LT	LV
<p>Noi, [1] Dichiariamo che il prodotto: Tipo di macchina: [2] Nome e modello: [3] Numero(i) di serie: [4] soddisfa tutte le disposizioni rilevanti della direttiva 2006/42/CE.</p> <p>Utilizzo degli standard armonizzati, come indicato nell'Articolo 7(2):</p> <p style="text-align: center;">EN ISO 4254-1:2013 EN ISO 4254-7:2009</p> <p>Luogo e data della dichiarazione: [5] Nome e firma della persona autorizzata a redigere la dichiarazione: [6] Nome e persona autorizzata a compilare il file tecnico: Benedikt von Riedesel General Manager, MacDon Europe GmbH Hagenauer Straße 59 65203 Wiesbaden (Germania) bvonriedesel@macdon.com</p>	<p>Mi, [1] Ezennel kijelentjük, hogy a következő termék: Gép típusa: [2] Név és modell: [3] Számszám(ok): [4] teljesíti a következő irányelv összes vonatkozó előírásait: 2006/42/EK.</p> <p>Az alábbi harmonizált szabványok kerültek alkalmazásra a 7(2) cikkely szerint:</p> <p style="text-align: center;">EN ISO 4254-1:2013 EN ISO 4254-7:2009</p> <p>A nyilatkozattétel ideje és helye: [5] Azon személy kiléte és aláírása, aki jogosult a nyilatkozat elkészítésére: [6] Azon személy neve és aláírása, aki felhatalmazott a műszaki dokumentáció összeállítására: Benedikt von Riedesel Vezérigazgató, MacDon Europe GmbH Hagenauer Straße 59 65203 Wiesbaden (Németország) bvonriedesel@macdon.com</p>	<p>Mes, [1] Pareiškiamė, kad šis produktas: Mašinos tipas: [2] Pavadinimas ir modelis: [3] Serijos numeris (-iai): [4] atitinka taikomus reikalavimus pagal Direktyvą 2006/42/EB.</p> <p>Naudojami harmonizuoti standartai, kai nurodoma straipsnyje 7(2):</p> <p style="text-align: center;">EN ISO 4254-1:2013 EN ISO 4254-7:2009</p> <p>Deklaracijos vieta ir data: [5] Asmens tapatybės duomenys ir parašas asmens, įgaliojoto sudaryti šią deklaraciją: [6] Vardas ir pavardė asmens, kuris įgaliojotas sudaryti šį techninį failą: Benedikt von Riedesel Generalinis direktorius, MacDon Europe GmbH Hagenauer Straße 59 65203 Wiesbaden (Vokietija) bvonriedesel@macdon.com</p>	<p>Mēs, [1] Deklarējam, ka produkts: Mašīnas tips: [2] Nosaukums un modelis: [3] Sērijas numurs(-i): [4] Atbilst visām būtiskajām Direktīvas 2006/42/EK prasībām.</p> <p>Piemēroti šādi saskaņotie standarti , kā minēts 7. panta 2. punktā:</p> <p style="text-align: center;">EN ISO 4254-1:2013 EN ISO 4254-7:2009</p> <p>Deklarācijas parakstīšanas vieta un datums: [5] Tās personas vārds, uzvārds un paraksts, kas ir pilnvarota sagatavot šo deklarāciju: [6] Tās personas vārds, uzvārds un adrese, kas ir pilnvarota sastādīt tehnisko dokumentāciju: Benedikts fon Rīdizels Ģenerāldirektors, MacDon Europe GmbH Hagenauer Straße 59 65203 Wiesbaden (Vācija) bvonriedesel@macdon.com</p>
<p>Wij, [1] Verklaren dat het product: Machinetype: [2] Naam en model: [3] Serienummer(s): [4] voldoet aan alle relevante bepalingen van de Richtlijn 2006/42/EC.</p> <p>Geharmoniseerde normen toegepast, zoals vermeld in Artikel 7(2):</p> <p style="text-align: center;">EN ISO 4254-1:2013 EN ISO 4254-7:2009</p> <p>Plaats en datum van verklaring: [5] Naam en handtekening van de bevoegde persoon om de verklaring op te stellen: [6] Naam en adres van de geautoriseerde persoon om het technisch dossier samen te stellen: Benedikt von Riedesel Algemeen directeur, MacDon Europe GmbH Hagenauer Straße 59 65203 Wiesbaden (Duitsland) bvonriedesel@macdon.com</p>	<p>My niżej podpisani, [1] Oświadczamy, że produkt: Typ urządzenia: [2] Nazwa i model: [3] Numer seryjny/numery seryjne: [4] spełnia wszystkie odpowiednie przepisy dyrektywy 2006/42/WE.</p> <p>Zastosowaliśmy następujące (zharmonizowane) normy zgodnie z artykułem 7(2):</p> <p style="text-align: center;">EN ISO 4254-1:2013 EN ISO 4254-7:2009</p> <p>Data i miejsce oświadczenia: [5] Imię i nazwisko oraz podpis osoby upoważnionej do przygotowania deklaracji: [6] Imię i nazwisko oraz adres osoby upoważnionej do przygotowania dokumentacji technicznej: Benedikt von Riedesel Dyrektor generalny, MacDon Europe GmbH Hagenauer Straße 59 65203 Wiesbaden (Niemcy) bvonriedesel@macdon.com</p>	<p>Nós, [1] Declarámos, que o produto: Tipo de máquina: [2] Nome e Modelo: [3] Número(s) de Série: [4] cumpre todas as disposições relevantes da Directiva 2006/42/CE.</p> <p>Normas harmonizadas aplicadas, conforme referido no Artigo 7(2):</p> <p style="text-align: center;">EN ISO 4254-1:2013 EN ISO 4254-7:2009</p> <p>Local e data da declaração: [5] Identidade e assinatura da pessoa autorizada a elaborar a declaração: [6] Nome e endereço da pessoa autorizada a compilar o ficheiro técnico: Benedikt von Riedesel Gerente Geral, MacDon Europa Ltda. Hagenauer Straße 59 65203 Wiesbaden (Alemanha) bvonriedesel@macdon.com</p>	<p>Noi, [1] Declarăm, că următorul produs: Tipul mașinii: [2] Denumirea și modelul: [3] Număr (numere) serie: [4] corespunde tuturor dispozițiilor esențiale ale directivei 2006/42/EC.</p> <p>Au fost aplicate următoarele standarde armonizate conform articolului 7(2):</p> <p style="text-align: center;">EN ISO 4254-1:2013 EN ISO 4254-7:2009</p> <p>Data și locul declarației: [5] Identitatea și semnătura persoanei împuternicite pentru întocmirea declarației: [6] Numele și semnătura persoanei autorizate pentru întocmirea cărții tehnice: Benedikt von Riedesel Manager General, MacDon Europe GmbH Hagenauer Straße 59 65203 Wiesbaden (Germania) bvonriedesel@macdon.com</p>
<p>Mi, [1] Izjavljujem da proizvod Tip mašine: [2] Naziv i model: [3] Serijski broj(ev): [4] Ispunjava sve relevantne odredbe direktive 2006/42/EC. Korišćeni su usklađeni standardi kao što je navedeno u članu 7(2): EN ISO 4254-1:2013 EN ISO 4254-7:2009 Datum i mesto izdavanja deklaracije: [5] Identitet i potpis lica ovlašćenog za sastavljanje deklaracije: [6] Ime i adresa osobe ovlašćene za sastavljanje tehničke datoteke: Benedikt von Riedesel Generalni direktor, MacDon Europe GmbH Hagenauer Straße 59 65203 Wiesbaden (Nemačka) bvonriedesel@macdon.com</p>	<p>Vi, [1] Intygat att produkten: Maskintyp: [2] Namn och modell: [3] Serienummer: [4] uppfyller alla relevanta villkor i direktivet 2006/42/EG. Harmoniserade standarder används, såsom anges i artikel 7(2): EN ISO 4254-1:2013 EN ISO 4254-7:2009 Plats och datum för intyget: [5] Identitet och signatur för person med befogenhet att upprätta intyget: [6] Namn och adress för person behörig att upprätta den tekniska dokumentationen: Benedikt von Riedesel Administrativ chef, MacDon Europe GmbH Hagenauer Straße 59 65203 Wiesbaden (Tyskland) bvonriedesel@macdon.com</p>	<p>Mi, [1] izjavljamo, da izdelek: Vrsta stroja: [2] Ime in model: [3] Serijska/-e številka/-e: [4] ustreza vsem zadevnim določbam Direktive 2006/42/ES. Uporabljeni usklajeni standardi, kot je navedeno v členu 7(2): EN ISO 4254-1:2013 EN ISO 4254-7:2009 Kraj in datum izjave: [5] Istovetnost in podpis osebe, opolnomočene za pripravo izjave: [6] Ime in naslov osebe, pooblaščenega za pripravo tehnične datoteke: Benedikt von Riedesel Generalni direktor, MacDon Europe GmbH Hagenauer Straße 59 65203 Wiesbaden (Nemčija) bvonriedesel@macdon.com</p>	<p>My, [1] týmto prehlasujem, že tento výrobok: Typ zariadenia: [2] Názov a model: [3] Výrobné číslo: [4] splňa príslušné ustanovenia a základné požiadavky smernice č. 2006/42/ES. Použitá harmonizované normy, ktoré sa uvádzajú v článku č. 7(2): EN ISO 4254-1:2013 EN ISO 4254-7:2009 Miesto a dátum prehlásenia: [5] Meno a podpis osoby oprávnenej vypracovať toto prehlásenie: [6] Meno a adresa osoby oprávnenej zostaviť technický súbor: Benedikt von Riedesel Generálny riaditeľ MacDon Europe GmbH Hagenauer Straße 59 65203 Wiesbaden (Nemecko) bvonriedesel@macdon.com</p>

1033472

Whole Body and Hand-Arm Vibration Levels

The weighted root mean square acceleration, to which the whole body is subjected, ranges from 0.46 to 1.52 m/s² as measured on a representative machine during typical operations and analyzed in accordance with ISO 5008.

During the same operations, the weighted root means square hand-arm vibration was less than 1.79 m/s² when analyzed in accordance with ISO 5349. These acceleration values depend on the ground roughness, operating speed, and the operator's experience, weight, and driving habits.

Noise Levels

The A-weighted sound pressure levels inside the operator's station ranged from 69.3 to 69.7 dB(A) as measured on several representative machines in accordance with ISO 5131. The sound pressure level depends upon the engine speed and load, field and crop conditions, and the type of platform used.

Introduction

This instruction manual contains information on the MacDon M1240 Windrower, which when coupled with one of MacDon's A40DX Auger Headers, D1X or D1XL Series Draper Headers, R85 Rotary Disc Headers, R113 Rotary Disc Headers, or R216 Rotary Disc Headers, provides a package designed to cut and lay a variety of crops into fluffy, uniform windrows.

Carefully read all the material provided before attempting to use the machine.

If you follow the instructions provided, your windrower will work well for many years.

Use this manual as your first source of information about the machine. If you follow the instructions provided, it will work well for many years. Contact your Dealer if you need assistance, information, or additional copies of this manual.

When setting up the machine or making adjustments, review and follow the recommended machine settings in all relevant MacDon publications. Failure to do so may compromise the machine function and machine life and may result in a hazardous situation.

MacDon provides warranty for Customers who operate and maintain their equipment as described in this manual. A copy of the MacDon Industries Limited Warranty Policy, which explains this warranty, should have been provided to you by your Dealer. Damage resulting from any of the following conditions will void the warranty:

- Accident
- Misuse
- Abuse
- Improper maintenance or neglect
- Abnormal or extraordinary use of the machine
- Failure to use the machine, equipment, component, or part in accordance with the manufacturer's instructions

The following conventions are used in this document:

- The M1240 Windrower is Dual Direction[®], meaning the windrower can be driven in cab-forward or engine-forward modes. Right and left designations are therefore determined from the operator's position, facing the direction of travel. This manual uses the terms "right cab-forward", "left cab-forward", "right engine-forward", and "left engine-forward" when referencing specific locations on the machine.
- Unless otherwise noted, use the standard torque values provided in Chapter *8.1 Torque Specifications, page 459* of this document.

Keep this manual handy for frequent reference and to pass on to new Operators or Owners. A manual storage case is located in the cab.

Call your MacDon Dealer if you need assistance, information, or additional copies of this manual.

NOTE:

Keep your MacDon publications up-to-date. The most current version can be downloaded from our website ([www.macdon.com](https://portal.macdon.com)) or from our Dealer-only site (<https://portal.macdon.com>) (login required).

This document is available in English only.

Summary of Changes

At MacDon, we're continuously making improvements. Occasionally these improvements affect product documentation. The following list provides an account of major changes from the previous version of this document.

Section	Summary of Change	Internal Use Only
<i>Declaration of Conformity, page i</i>	Updated Declaration of Conformity for model year 2021.	Safety, Tech Pubs
<i>1.12 Understanding Safety Signs, page 18</i>	Removed decal MD #113842 for model year 2021. Decal is not present on windrower.	Safety, Tech Pubs
<i>2.2 Specifications, page 30</i>	Updated listed bundle in footnote to MD #B6889.	ECN 59731
<i>3.17 Harvest Performance Tracker Display, page 77</i>	Added illustration.	Tech Pubs
<i>Faults and Telltales, page 88</i>	Added note.	Tech Pubs
<i>Setting Screen Brightness, page 90</i>	Updated illustrations.	Tech Pubs
<i>Setting Alarm Volume, page 91</i>	Updated illustrations.	Tech Pubs
<i>Clearing Fault Codes, page 94</i>	Added new topic.	Product Support
<i>3.17.4 Setting Windrower Tire Size, page 98</i>	Added step for selecting high torque final drives option.	ECN 58568, Product Support
<i>Adding Engine Oil, page 118</i>	Added new topic.	Tech Pubs
<i>Driving Forward in Engine-Forward Mode, page 134</i>	Updated illustration.	Tech Pubs
<i>4.4.4 R85 4.9 m (16 ft.) Rotary Disc Header, page 200</i>	Added topic.	Product Support, Tech Pubs
<i>Attaching an R85 4.9 m (16 ft.) Rotary Disc Header, page 200</i>	Added topic.	Product Support, Tech Pubs
<i>Connecting R85 4.9 m (16 ft.) Rotary Disc Header Hydraulics, page 206</i>	Added topic.	Product Support, Tech Pubs
<i>Detaching R85 4.9 m (16 ft.) Rotary Disc Header, page 208</i>	Added topic.	Product Support, Tech Pubs
<i>4.6.1 Calibrating the Knife Drive on the Harvest Performance Tracker Display, page 213</i>	New topic, includes note and illustration to show knife drive calibration error message.	ECN 59931
<i>4.6.2 Calibrating Header Position Sensors on the Harvest Performance Tracker Display, page 216</i>	Added new topic.	Tech Pubs
<i>4.7.5 Setting Header Height, page 229</i>	Added note and updated illustration to explain automatic reel movement for draper headers.	Tech Pubs, Product Support

Section	Summary of Change	Internal Use Only
<i>4.8.2 Adjusting Reel Fore-Aft Position, page 234</i>	Added information and illustration to explain automatic reel movement for draper headers.	Tech Pubs, Product Support
<i>4.8.3 Adjusting Reel Height, page 235</i>	Added information and illustration to explain automatic reel movement for draper headers.	Tech Pubs, Product Support
<i>Replacing LED Lights – Deluxe Cab Only, page 414</i>	Updated note for replacing LED lights on deluxe cab.	ECN 59731
<i>6.1.2 Windrower Lighting Upgrade – Eight LED Work Lights, Standard on Deluxe Cab Package, page 439</i>	Updated description for lighting upgrade bundle (MD #B6889) for standard cab packages.	ECN 59731
<i>8.3 Windrower Fault Codes, page 468</i>	Removed fault code SA 104, SPN 521508, FMI (“Lift/Fan Hyd Unstable”).	ECN 59931
<i>8.3 Windrower Fault Codes, page 468</i>	Added fault codes for SA 104, SPN 521530, FMI (“Reel Pressure High”) and SA 104, SPN 521531, FMI (“Conveyor Pressure High”).	ECN 59931

Serial Numbers

Record the model number, serial number, and year of manufacture of the windrower and engine on the lines below.

The windrower serial number plate (A) is located on the left side of the main frame near the walking beam.

Windrower Serial Number: _____

Model Year: _____

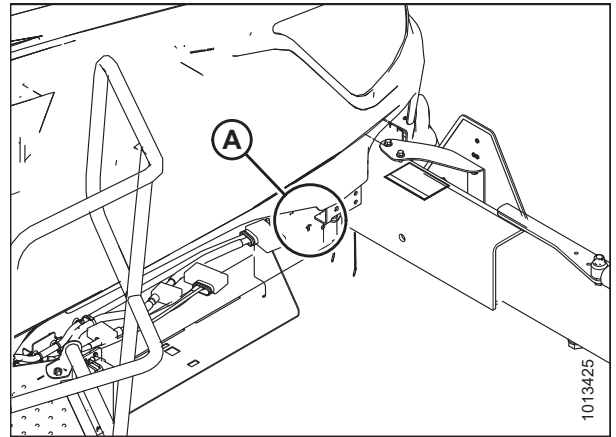

Figure 1: Windrower Serial Number Location

The engine serial number plate (A) is located on top of the engine cylinder head cover.

Engine Serial Number: _____

Model Year: _____



Figure 2: Engine Serial Number Location

TABLE OF CONTENTS

Declaration of Conformity	i
Whole Body and Hand-Arm Vibration Levels	iii
Noise Levels.....	iii
Introduction	iv
Summary of Changes.....	v
Serial Numbers.....	vii
Chapter 1: Safety	1
1.1 Safety Alert Symbols	1
1.2 Signal Words	2
1.3 General Safety	3
1.4 Maintenance Safety	5
1.5 Hydraulic Safety	6
1.6 Tire Safety.....	7
1.7 Battery Safety	8
1.8 Welding Precaution	9
1.9 Engine Safety.....	13
1.9.1 High-Pressure Rail	13
1.9.2 Engine Electronics	14
1.10 Safety Signs	15
1.10.1 Installing Safety Decals.....	15
1.11 Safety Sign Locations	16
1.12 Understanding Safety Signs	18
Chapter 2: Product Overview	27
2.1 Definitions	27
2.2 Specifications.....	30
2.3 Windrower Dimensions	33
2.4 Component Location.....	34
Chapter 3: Operator's Station	37
3.1 Console	37
3.2 Operator Presence System	39
3.2.1 Header Drive.....	39
3.2.2 Engine and Transmission	39
3.3 Operator's Seat Adjustments.....	40
3.3.1 Armrest.....	40
3.3.2 Armrest Angle	41
3.3.3 Suspension and Height.....	41
3.3.4 Fore-Aft Slide Control	42
3.3.5 Fore-Aft Isolator Control	42
3.3.6 Tilt	43

TABLE OF CONTENTS

3.3.7 Lumbar Support	43
3.3.8 Vertical Dampener	44
3.3.9 Cushion Tilt – Deluxe Cab Only	44
3.3.10 Cushion Extension – Deluxe Cab Only	45
3.3.11 Lateral Isolation Lockout – Deluxe Cab Only	45
3.3.12 Heating/Cooling – Deluxe Cab Only	46
3.4 Training Seat	47
3.5 Seat Belts	48
3.6 Adjusting the Steering Column and Steering Wheel	50
3.7 Lighting	51
3.7.1 Cab-Forward Lighting – Field	51
3.7.2 Cab-Forward Lighting – Road	52
3.7.3 Engine-Forward Lighting – Road	53
3.7.4 Tail/Beacon Lighting	55
3.7.5 Turn Signal / Hazard Lighting.....	56
3.8 Windshield Wipers.....	57
3.9 Rear View Mirrors	58
3.10 Cab Temperature.....	59
3.10.1 Heater Shut-Off Valve	59
3.10.2 Air Distribution	59
3.10.3 Climate Controls	60
3.11 Operator Amenities.....	61
3.12 Radio.....	63
3.12.1 AM/FM/CD/USB Radio with Bluetooth® Wireless Technology	63
Activating Bluetooth® Feature	64
Pairing a Bluetooth® Device.....	65
3.13 Horn.....	66
3.14 Engine Controls	67
3.14.1 Using Eco Engine Control	68
3.15 Windrower Controls	69
3.16 Header Controls	70
3.16.1 Header Engage Switch.....	70
3.16.2 Header Drive Reverse Button	70
3.16.3 Ground Speed Lever Switches.....	71
Header Position Six-Way Switch	72
Reel Position Four-Way Switch	73
Reel and Disc Speed Switch	73
One-Touch-Return Buttons (A, B, C)	74
3.16.4 Console Header Buttons	75
Deck Shift / Float Presets	75
Conveyor Speed Adjustment Buttons	76
Auxiliary Lift Switches.....	76
3.17 Harvest Performance Tracker Display	77
3.17.1 Harvest Performance Tracker Screen Layout	77

TABLE OF CONTENTS

3.17.2 Navigating the Harvest Performance Tracker Display	80
Scroll Knob, Scroll Wheel, and Select Button.....	80
Home, Back, and Select Buttons	81
Soft Keys	81
QuickMenu System	82
Main Menu.....	83
Menu Icons	84
Faults and Telltales	88
3.17.3 Setting up the Harvest Performance Tracker Screen	90
Setting Screen Brightness.....	90
Setting Alarm Volume.....	91
Setting Time and Date	92
Setting Language and Units of Measurement.....	93
Clearing Fault Codes.....	94
Resetting to Factory Defaults.....	96
3.17.4 Setting Windrower Tire Size	98
3.17.5 Activating Control Locks	99
3.17.6 Machine Information Pages	100
Accessing Windrower Information	100
Accessing Header Information	101
Accessing Software Information	102
Accessing Performance Information.....	103
3.17.7 F1 to F6 Function Buttons.....	105
Chapter 4: Operation	107
4.1 Owner/Operator Responsibilities	107
4.2 Symbol Definitions.....	108
4.2.1 Windrower Operating Symbols.....	108
4.2.2 Harvest Performance Tracker Symbols.....	109
4.3 Operating the Windrower	111
4.3.1 Operational Safety	111
4.3.2 Break-in Period.....	112
4.3.3 Preseason Checks / Annual Service	113
Air Conditioning Compressor Coolant Cycling	114
4.3.4 Daily Checks and Maintenance	115
Filling Fuel Tank.....	115
Filling the Diesel Exhaust Fluid Tank.....	116
Checking Engine Oil Level.....	117
Adding Engine Oil	118
4.3.5 Engine Operation.....	119
Starting the Engine	119
Engine Start Troubleshooting Tips.....	123
Programming the Eco Engine Control	124
Shutting down the Engine	125
Engine Temperature.....	125
Engine Oil Pressure	126
Exhaust System Cleaning.....	126
Activating the Exhaust Aftertreatment Functions.....	127
Viewing Engine Cooling Data	128
4.3.6 Operating the Windrower.....	129

TABLE OF CONTENTS

Entering and Exiting the Windrower.....	129
Adjusting Ground Speed Limit.....	130
Driving Forward in Cab-Forward Mode.....	131
Driving in Reverse in Cab-Forward Mode.....	133
Driving Forward in Engine-Forward Mode.....	134
Driving in Reverse in Engine-Forward Mode.....	136
Spin Turning.....	137
Stopping.....	137
Viewing Performance Data.....	138
4.3.7 Transporting.....	139
Driving on Road in Engine-Forward Mode.....	139
Driving on Road in Cab-Forward Mode.....	142
Towing Header with Windrower.....	145
Preparing Windrower to Tow a Header.....	146
Towing the Windrower – Emergency.....	148
Engaging and Disengaging Final Drives.....	149
4.3.8 Storing the Windrower.....	150
4.4 Attaching and Detaching a Header.....	151
4.4.1 A40DX Auger Header.....	151
Attaching A40DX Auger Header.....	151
Connecting A40DX Auger Hydraulics.....	157
Detaching an A40DX Auger Header.....	159
4.4.2 D1X or D1XL Series Draper Header.....	162
Attaching Draper Header Supports.....	162
Attaching D1X or D1XL Series Draper Header.....	163
Connecting D1X or D1XL Series Draper Header Hydraulics.....	169
Detaching D1X or D1XL Series Draper Header.....	171
4.4.3 R113 or R216 Rotary Disc Header.....	175
Attaching R113 or R216 Rotary Disc Header.....	175
Connecting R113 or R216 Rotary Disc Header Hydraulics.....	181
Detaching R113 Rotary Disc Header.....	191
Detaching R216 Rotary Disc Header.....	196
4.4.4 R85 4.9 m (16 ft.) Rotary Disc Header.....	200
Attaching an R85 4.9 m (16 ft.) Rotary Disc Header.....	200
Connecting R85 4.9 m (16 ft.) Rotary Disc Header Hydraulics.....	206
Detaching R85 4.9 m (16 ft.) Rotary Disc Header.....	208
4.5 Adjusting Header Settings on the Harvest Performance Tracker.....	212
4.6 Calibrating the Header Systems.....	213
4.6.1 Calibrating the Knife Drive on the Harvest Performance Tracker Display.....	213
4.6.2 Calibrating Header Position Sensors on the Harvest Performance Tracker Display.....	216
4.7 Operating a Header.....	219
4.7.1 Engaging and Disengaging Header Safety Props.....	219
4.7.2 Header Float.....	220
Checking Float.....	221
Setting the Float.....	222
Removing and Restoring Float.....	224
4.7.3 Header Drive.....	225
Engaging and Disengaging the Header.....	225
Reversing the Header.....	226
4.7.4 Adjusting Header Angle.....	227

TABLE OF CONTENTS

Checking Self-Locking Center-Link Hook	228
4.7.5 Setting Header Height	229
4.7.6 Double Windrowing	229
Double Windrow Attachment Deck Position	230
Double Windrow Attachment Conveyor Speed	230
4.7.7 One-Touch-Return	231
4.7.8 Adjusting Header Raise and Lower Rates	232
4.8 Operating with D1X or D1XL Series Draper Header	234
4.8.1 Header Position	234
4.8.2 Adjusting Reel Fore-Aft Position	234
4.8.3 Adjusting Reel Height	235
4.8.4 Leveling the Header	236
4.8.5 Adjusting Reel Speed	238
Setting Reel Speed in Auto Mode	238
Setting Reel Speed in Manual Mode	240
Adjusting Reel Alarm Pressure	241
4.8.6 Adjusting Draper Speed	243
Setting Draper Speed in Auto Mode	243
Setting Draper Speed in Manual Mode	245
Adjusting Draper Alarm Pressure	246
Draper Slip Warning	248
4.8.7 Knife Speed	249
Setting Knife Speed	250
Adjusting Knife Alarm Pressure – Draper Header	251
Adjusting Knife Speed Alarm	252
4.8.8 Deck Shift Control	254
Shifting Decks	254
Setting Float Options with Deck Shift	255
4.8.9 Draper Header Run Screens	256
Run Screen 1	257
Run Screen 2	258
4.8.10 Swath Compressor	259
Swath Compressor Controls	259
Locking and Unlocking the Swath Compressor	261
4.9 Operating with an A40DX Auger Header	262
4.9.1 Reel and Auger Speed	262
Setting Reel Speed in Auto Mode	262
Setting Reel Speed in Manual Mode	264
Setting Auger Speed	266
Adjusting the Reel/Auger Alarm Pressure	267
4.9.2 Knife Speed	269
Setting Knife Speed	269
Adjusting Knife Alarm Pressure – Auger Header	271
Adjusting Knife Speed Alarm	272
4.9.3 Setting Float Options with Fixed Deck	274
4.9.4 Auger Header Run Screens	276
Run Screen 1	276
Run Screen 2	277
4.10 Operating with an R85 Rotary Disc Header	278

TABLE OF CONTENTS

4.10.1 Setting Disc Speed	278
4.10.2 Adjusting Disc Pressure Alarm	279
4.10.3 Setting Float Options with Fixed Deck	281
4.10.4 Disc Header Run Screens	283
Run Screen 1	283
Run Screen 2	284
4.11 Operating with an R113 or R216 Rotary Disc Header	285
4.11.1 Disc Speed	285
Setting Disc Speed	285
Adjusting Disc Pressure Alarm	286
4.11.2 Setting Float Options with Fixed Deck	288
4.11.3 Disc Header Run Screens	290
Run Screen 1	290
Run Screen 2	291
Chapter 5: Maintenance and Servicing	293
5.1 Recommended Fuel, Fluids, and Lubricants	293
5.1.1 Storing Lubricants and Fluids	293
5.1.2 Fuel Specifications	294
5.1.3 Lubricants, Fluids, and System Capacities	295
5.1.4 Filter Part Numbers	297
5.2 Windrower Break-In Inspections and Maintenance Schedule	298
5.2.1 Break-in Inspection Schedule	298
5.2.2 Maintenance Schedule/Record	299
5.2.3 Using the Electronic Maintenance Tool	301
5.3 Engine Compartment	302
5.3.1 Opening Hood	302
5.3.2 Closing Hood	303
5.4 Platform	304
5.4.1 Opening Platform	304
5.4.2 Closing Platform	304
5.4.3 Adjusting the Platform	305
5.4.4 Accessing Tool Box	306
5.5 System Maintenance Overviews	307
5.5.1 Diesel Exhaust Fluid System	307
Draining the Diesel Exhaust Fluid Tank	307
Filling the Diesel Exhaust Fluid Tank	308
5.5.2 Twin-Flow Cooling System	309
Engine Cooling	310
Inspecting Pressurized Coolant Tank Cap	310
Charge Air Cooler	311
Charge Air Cooling	312
Hydraulic Oil Cooler	312
Air Conditioning (A/C)	313
Condenser	313
5.5.3 Air Intake System	314
5.5.4 Hydraulic System	315

TABLE OF CONTENTS

Hydraulic Oil Cooler	316
Knife/Disc Drive Hydraulics.....	316
Reel and Draper Hydraulics	316
Traction Drive Hydraulics	316
5.5.5 Electrical System	317
Module Layout.....	317
Master Controller	321
Extension Modules.....	321
Relay Modules	321
Preventing Electrical System Damage	322
5.6 Break-In Inspection Procedures.....	323
5.6.1 Tightening Drive Wheel Nuts.....	323
5.6.2 Tightening Caster Wheel Nuts	324
5.6.3 Tightening Caster Wheel Anti-Shimmy Dampeners.....	325
5.6.4 Tightening Walking Beam Adjustment Bolts	325
5.6.5 Tensioning Air Conditioner Compressor Belts.....	326
5.6.6 Changing Engine Gearbox Lubricant	327
5.6.7 Changing Wheel Drive Lubricant – 10 Bolt	328
5.6.8 Changing Wheel Drive Lubricant – 12 Bolt (Optional)	329
5.6.9 Return Oil Filter	330
Removing Return Oil Filter	330
Installing Return Oil Filter.....	331
5.6.10 Charge Filter.....	332
Removing Charge Filter.....	332
Installing Charge Filter	333
5.7 Every 10 Hours or Daily	334
5.7.1 Checking Engine Oil Level	334
Adding Engine Oil	335
5.7.2 Fuel/Water Separator	336
Removing Water from Fuel System	336
5.7.3 Checking Hydraulic Oil	337
5.7.4 Checking Tire Pressures.....	338
5.7.5 Checking Engine Coolant Level	341
5.7.6 Hoses and Lines	342
5.7.7 Checking Engine Gearbox Lubricant Level and Adding Lubricant	343
5.8 Every 50 Hours.....	344
5.8.1 Fresh Air Intake Filter	344
Removing Fresh Air Intake Filter.....	344
Inspecting and Cleaning Fresh Air Intake Filter Element.....	345
Installing Fresh Air Intake Filter	346
5.8.2 Greasing the Windrower	347
Greasing Procedure.....	348
Grease Points.....	348
5.9 Every 100 Hours	349
5.9.1 Servicing Return Air Filter	349
5.9.2 Cleaning Cooler Module	350
Cleaning Left Cooling Module	350
Cleaning Right Cooling Module.....	353

TABLE OF CONTENTS

5.10	Every 250 Hours or Annually	356
5.10.1	Changing Engine Oil	356
	Draining Engine Oil	356
	Replacing Engine Oil Filter	357
	Adding Engine Oil	357
5.10.2	Maintaining Engine Air Filters	358
	Removing Engine Primary Air Filter	358
	Installing Engine Primary Air Filter	360
	Cleaning Primary Air Filter	361
	Replacing Secondary Air Filter	361
5.10.3	Checking Wheel Drive Lubricant Level	363
5.10.4	Checking Wheel Drive Lubricant Level – 12 Bolt (Optional)	363
5.10.5	Adding Wheel Drive Lubricant – 10 Bolt	364
5.10.6	Adding Wheel Drive Lubricant – 12 Bolt (Optional)	365
5.10.7	Inspecting Exhaust System	365
5.10.8	Changing Engine Gearbox Lubricant	367
5.11	Every 500 Hours or Annually	369
5.11.1	Maintaining Fuel Filters	369
	Removing Primary Fuel Filter	369
	Installing Primary Fuel Filter	370
	Removing Secondary Fuel Filter	370
	Installing Secondary Fuel Filter	371
	Priming Fuel System	371
5.11.2	Safety Systems	372
	Checking Operator Presence System	372
	Checking Engine Interlock	374
5.12	Every 1000 Hours	375
5.12.1	Removing and Installing the Fuel Tank Vent Filter	375
5.12.2	Diesel Exhaust Fluid Supply Module Filter	377
	Checking the DEF Supply Module Filter	377
	Removing the Supply Module Filter	377
	Cleaning and Inspecting the Supply Module Filter	379
	Installing the Supply Module Filter	379
5.13	Every 2000 Hours	380
5.13.1	Changing Engine Coolant	380
	Draining Coolant	380
	Adding Coolant	381
5.13.2	Draining Hydraulic Oil	382
5.13.3	Filling Hydraulic Oil	384
5.13.4	Replacing the Diesel Exhaust Fluid Vent Hose Filter	385
5.13.5	General Engine Inspection	385
5.14	Annual Service	386
5.14.1	Batteries	386
	Maintaining a Battery	386
	Opening Battery Cover	387
	Closing Battery Cover	387
	Charging a Battery	388
	Boosting a Battery	390
	Removing a Battery	391

TABLE OF CONTENTS

Installing a Battery	392
Disconnecting a Battery	393
Connecting Batteries	393
Auxiliary Power Posts	395
5.14.2 Checking Steering Link Pivots	395
5.14.3 Air Conditioning Evaporator	397
Removing Air Conditioning Cover	397
Cleaning Air Conditioning Evaporator Core	398
Installing Air Conditioning Cover	399
5.14.4 Checking Engine Coolant Strength	400
5.15 Maintenance as Required	401
5.15.1 Seat Belts	401
5.15.2 Draining Fuel Tank	401
5.15.3 Draining the Diesel Exhaust Fluid Tank	402
5.15.4 Belts	403
Tensioning Engine Fan Drive Belt	403
Replacing Engine Fan Drive Belt	403
Tensioning Air Conditioner Compressor Belts	404
Replacing Air Conditioner Compressor Belts	405
5.15.5 Engine Speed	405
5.15.6 Lighting	406
Aligning Headlights – Engine-Forward	406
Aligning Headlights – Cab-Forward	407
Adjusting Front Field Lights	408
Adjusting Rear Roof Work Lights	409
Adjusting Rear Swath Lights	410
Replacing Bulbs in Standard Work Lights	411
Replacing Headlight Bulb – Engine-Forward	412
Replacing LED Lights – Deluxe Cab Only	414
Replacing Bulbs in Red and Amber Lights	415
Replacing Red Tail Lights	416
Replacing Beacon Lights	416
Replacing the Cabin Dome Bulb	417
Replacing the Cabin Dome Light Assembly	418
Turn Signal Indicators	419
5.15.7 Accessing Circuit Breakers and Fuses	420
Checking and Replacing Fuses	421
Replacing Circuit Breakers and Relays	422
Fuse Panel and Relay Module Decals	423
Inspecting and Replacing 125A Main Fuses	428
5.15.8 Drive Wheels	429
Raising Drive Wheel	429
Removing Drive Wheels	430
Installing Drive Wheels	431
Lowering Drive Wheel	433
5.15.9 Caster Wheels	433
Adjusting Caster Tread Width	433
Installing Forked Caster Wheel	435
Removing Forked Caster Wheel	436
Lowering Caster Wheel	437
Raising Caster Wheel	437

TABLE OF CONTENTS

Chapter 6: Options and Attachments	439
6.1 Cab	439
6.1.1 Automated Steering Systems	439
6.1.2 Windrower Lighting Upgrade – Eight LED Work Lights, Standard on Deluxe Cab Package	439
6.2 Header Operation.....	440
6.2.1 Conversion Kit for Disc Ready to Disc, Auger, and Draper Ready	440
6.2.2 Booster Spring Kit – External	440
6.2.3 Double Booster Spring Kit – External	441
6.2.4 Double Windrow Attachment.....	441
6.2.5 Double Windrow Attachment Shut-Off Kit	441
6.2.6 Center-Link Lifter	442
6.2.7 Swath Compressor	442
6.3 Transport.....	443
6.3.1 Ballast.....	443
6.3.2 Single Side Mud Caster Wheels.....	444
6.3.3 Towing Harness	444
6.3.4 Weight Box	444
Chapter 7: Troubleshooting.....	445
7.1 Engine Troubleshooting	445
7.2 Electrical Troubleshooting.....	449
7.3 Hydraulics Troubleshooting	450
7.4 Header Drive Troubleshooting	451
7.5 Traction Drive Troubleshooting	452
7.6 Steering and Ground Speed Control Troubleshooting.....	454
7.7 Cab Air Troubleshooting	455
7.8 Operator’s Station Troubleshooting	458
Chapter 8: Reference	459
8.1 Torque Specifications	459
8.1.1 Metric Bolt Specifications	459
8.1.2 Metric Bolt Specifications Bolting into Cast Aluminum.....	461
8.1.3 O-Ring Boss Hydraulic Fittings – Adjustable	462
8.1.4 O-Ring Boss Hydraulic Fittings – Non-Adjustable.....	464
8.1.5 O-Ring Face Seal Hydraulic Fittings.....	465
8.1.6 Tapered Pipe Thread Fittings.....	466
8.2 Conversion Chart.....	467
8.3 Windrower Fault Codes	468
8.4 Engine Fault Codes	514
Index.....	547
Lubricants, Fluids, and System Capacities	561

Chapter 1: Safety

1.1 Safety Alert Symbols

The safety alert symbol indicates important safety messages in this manual and on safety signs on the machine.

This symbol means:

- **ATTENTION!**
- **BECOME ALERT!**
- **YOUR SAFETY IS INVOLVED!**

Carefully read and follow the safety message accompanying this symbol.

Why is safety important to you?

- Accidents disable and kill
- Accidents cost
- Accidents can be avoided



Figure 1.1: Safety Symbol

1.2 Signal Words

Three signal words, **DANGER**, **WARNING**, and **CAUTION**, are used to alert you to hazardous situations. Two signal words, **IMPORTANT** and **NOTE**, identify non-safety related information.

Signal words are selected using the following guidelines:

DANGER

Indicates an imminently hazardous situation that, if not avoided, will result in death or serious injury.

WARNING

Indicates a potentially hazardous situation that, if not avoided, could result in death or serious injury. It may also be used to alert against unsafe practices.

CAUTION

Indicates a potentially hazardous situation that, if not avoided, may result in minor or moderate injury. It may be used to alert against unsafe practices.

IMPORTANT:

Indicates a situation that, if not avoided, could result in a malfunction or damage to the machine.

NOTE:

Provides additional information or advice.

1.3 General Safety

Protect yourself when assembling, operating, and servicing machinery.

CAUTION

The following general farm safety precautions should be part of your operating procedure for all types of machinery.

Wear all protective clothing and personal safety devices that could be necessary for the job at hand. Do **NOT** take chances. You may need the following:

- Hard hat
- Protective footwear with slip-resistant soles
- Protective glasses or goggles
- Heavy gloves
- Wet weather gear
- Respirator or filter mask

In addition, take the following precautions:

- Be aware that exposure to loud noises can cause hearing impairment or loss. Wear suitable hearing protection devices such as earmuffs or earplugs to help protect against loud noises.



Figure 1.2: Safety Equipment



Figure 1.3: Safety Equipment

- Provide a first aid kit in case of emergencies.
- Keep a properly maintained fire extinguisher on the machine. Be familiar with its proper use.
- Keep young children away from machinery at all times.
- Be aware that accidents often happen when the Operator is tired or in a hurry. Take time to consider the safest way. **NEVER** ignore warning signs of fatigue.

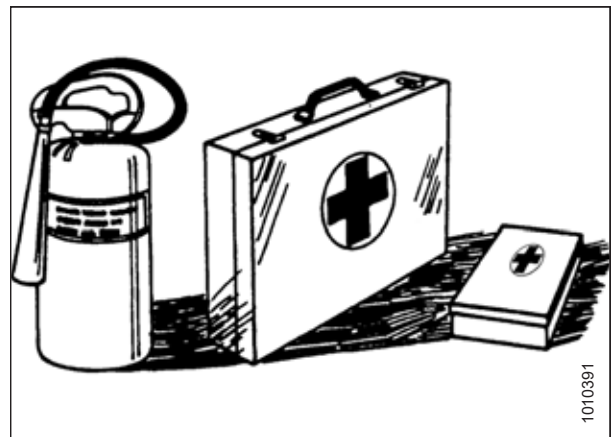

Figure 1.4: Safety Equipment

SAFETY

- Wear close-fitting clothing and cover long hair. **NEVER** wear dangling items such as scarves or bracelets.
- Keep all shields in place. **NEVER** alter or remove safety equipment. Make sure driveline guards can rotate independently of shaft and can telescope freely.
- Use only service and repair parts made or approved by equipment manufacturer. Substituted parts may not meet strength, design, or safety requirements.



Figure 1.5: Safety around Equipment

- Keep hands, feet, clothing, and hair away from moving parts. **NEVER** attempt to clear obstructions or objects from a machine while the engine is running.
- Do **NOT** modify the machine. Unauthorized modifications may impair machine function and/or safety. It may also shorten the machine's life.
- To avoid injury or death from unexpected startup of the machine, **ALWAYS** stop the engine and remove the key from the ignition before leaving the operator's seat for any reason.

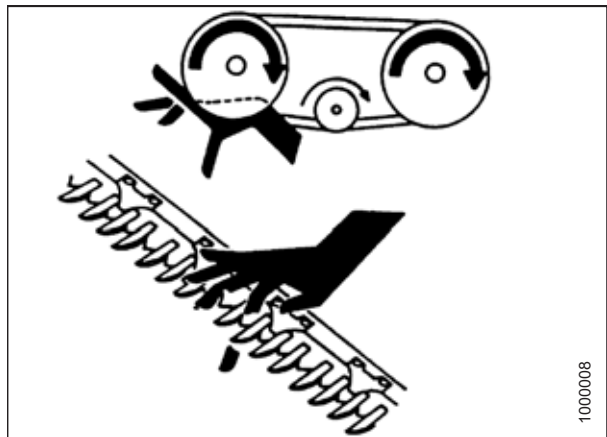

Figure 1.6: Safety around Equipment

- Keep service area clean and dry. Wet and/or oily floors are slippery. Wet spots can be dangerous when working with electrical equipment. Be sure all electrical outlets and tools are properly grounded.
- Keep work area well lit.
- Keep machinery clean. Straw and chaff on a hot engine are fire hazards. Do **NOT** allow oil or grease to accumulate on service platforms, ladders, or controls. Clean machines before storage.
- **NEVER** use gasoline, naphtha, or any volatile material for cleaning purposes. These materials may be toxic and/or flammable.
- When storing machinery, cover sharp or extending components to prevent injury from accidental contact.



Figure 1.7: Safety around Equipment

1.4 Maintenance Safety

To ensure your safety while maintaining machine:

- Review the operator's manual and all safety items before operation and/or maintenance of the machine.
- Place all controls in Neutral, stop the engine, set the park brake, remove the ignition key, and wait for all moving parts to stop before servicing, adjusting, and/or repairing.
- Follow good shop practices:
 - Keep service areas clean and dry
 - Be sure electrical outlets and tools are properly grounded
 - Keep work area well lit
- Relieve pressure from hydraulic circuits before servicing and/or disconnecting the machine.
- Make sure all components are tight and that steel lines, hoses, and couplings are in good condition before applying pressure to hydraulic systems.
- Keep hands, feet, clothing, and hair away from all moving and/or rotating parts.
- Clear the area of bystanders, especially children, when carrying out any maintenance, repairs, or adjustments.
- Install transport lock or place safety stands under the frame before working under the machine.
- If more than one person is servicing the machine at the same time, be aware that rotating a driveline or other mechanically-driven component by hand (for example, accessing a lubricant fitting) will cause drive components in other areas (belts, pulleys, and knives) to move. Stay clear of driven components at all times.
- Wear protective gear when working on the machine.
- Wear heavy gloves when working on knife components.



Figure 1.8: Safety around Equipment

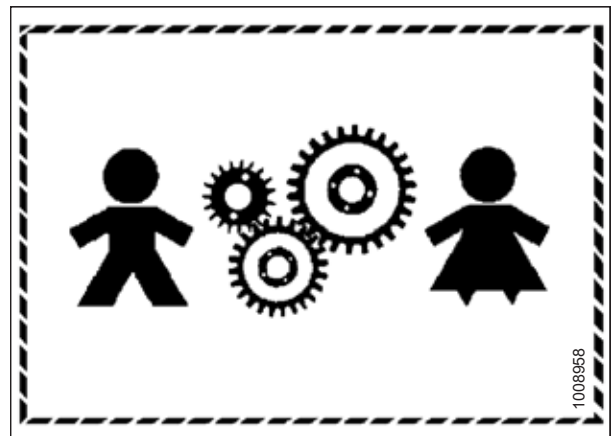

Figure 1.9: Equipment NOT Safe for Children



Figure 1.10: Safety Equipment

1.5 Hydraulic Safety

- Always place all hydraulic controls in Neutral before leaving the operator's seat.
- Make sure that all components in the hydraulic system are kept clean and in good condition.
- Replace any worn, cut, abraded, flattened, or crimped hoses and steel lines.
- Do **NOT** attempt any makeshift repairs to hydraulic lines, fittings, or hoses by using tapes, clamps, cements, or welding. The hydraulic system operates under extremely high-pressure. Makeshift repairs will fail suddenly and create hazardous and unsafe conditions.

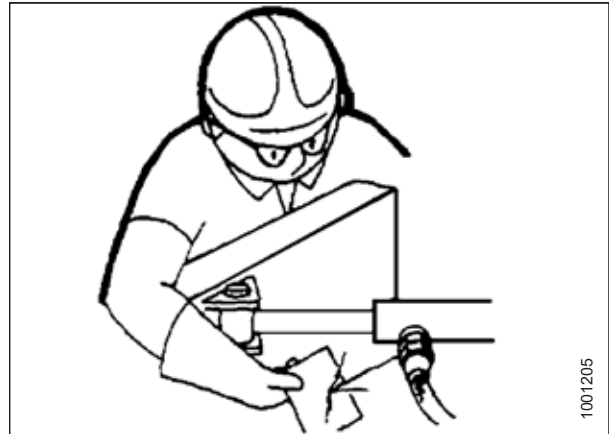

Figure 1.11: Testing for Hydraulic Leaks

- Wear proper hand and eye protection when searching for high-pressure hydraulic leaks. Use a piece of cardboard as a backstop instead of hands to isolate and identify a leak.
- If injured by a concentrated high-pressure stream of hydraulic fluid, seek medical attention immediately. Serious infection or toxic reaction can develop from hydraulic fluid piercing the skin.



Figure 1.12: Hydraulic Pressure Hazard

- Make sure all components are tight and steel lines, hoses, and couplings are in good condition before applying pressure to a hydraulic system.

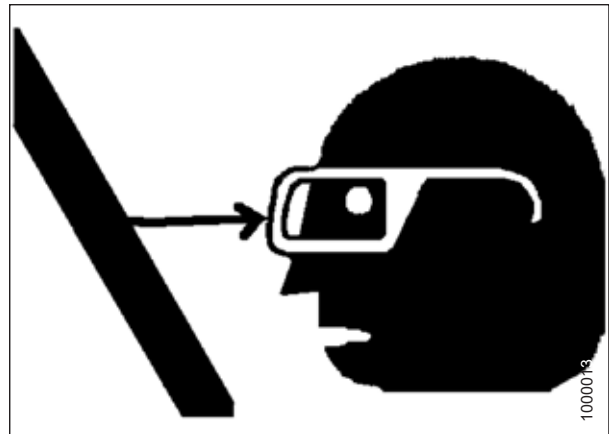

Figure 1.13: Safety around Equipment

1.6 Tire Safety

Service tires safely.

WARNING

- A tire can explode during inflation, which could cause serious injury or death.
- Follow proper procedures when mounting a tire on a wheel or rim. Failure to do so can produce an explosion that may result in serious injury or death.



Figure 1.14: Overinflated Tire

WARNING

- Do NOT remove, install, or repair a tire on a rim unless you have proper equipment and experience to perform job. Take the tire and rim to a qualified tire repair shop.
- Make sure the tire is correctly seated before inflating to operating pressure. If the tire is not correctly positioned on the rim or is overinflated, the tire bead can loosen on one side causing air to escape at high speed and with great force. An air leak of this nature can thrust the tire in any direction, endangering anyone in area.
- Do NOT stand over tire when inflating. Use a clip-on chuck and extension hose.
- Do NOT exceed maximum inflation pressure indicated on tire label.
- Never use force on an inflated or partially inflated tire.
- Make sure all air is removed from the tire before removing the tire from the rim.
- Never weld a wheel rim.
- Replace tires that have defects and replace wheel rims that are cracked, worn, or severely rusted.



Figure 1.15: Safely Inflating Tire

1.7 Battery Safety

WARNING

- Keep all sparks and flames away from batteries; an explosive gas is given off by electrolyte.
- Ventilate when charging in enclosed space.



Figure 1.16: Safety around Batteries

WARNING

- Wear safety glasses when working near batteries.
- To avoid an electrolyte loss, do NOT tip batteries more than 45°.
- Battery electrolyte causes severe burns. Avoid contact with skin, eyes, or clothing.
- Electrolyte splashed into eyes is extremely dangerous. Should this occur, force eye open, and flood with cool, clean water for 5 minutes. Call a doctor immediately.
- If electrolyte is spilled or splashed on clothing or body, neutralize it immediately with a solution of baking soda and water, then rinse with clear water.

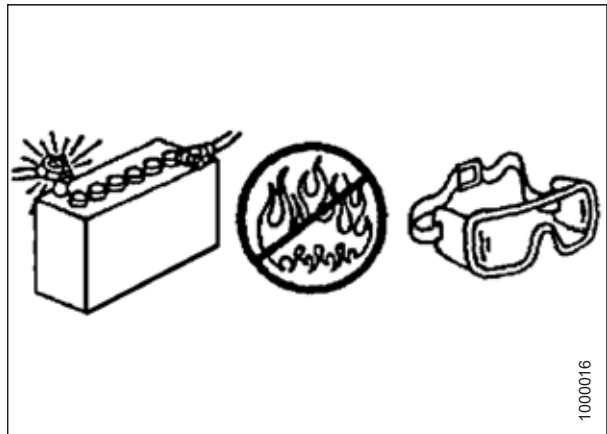

Figure 1.17: Safety around Batteries

WARNING

- To avoid injury from a spark or short circuit, disconnect the battery ground cable before servicing any part of the electrical system.
- Do NOT operate the engine with the alternator or battery disconnected. With battery cables disconnected and the engine running, a high voltage can be built up if terminals touch frame. Anyone touching the frame under these conditions would be severely shocked.
- When working around storage batteries, remember that all of the exposed metal parts are live. Never lay a metal object across the terminals because a spark or short circuit will result.
- Keep batteries out of reach of children.

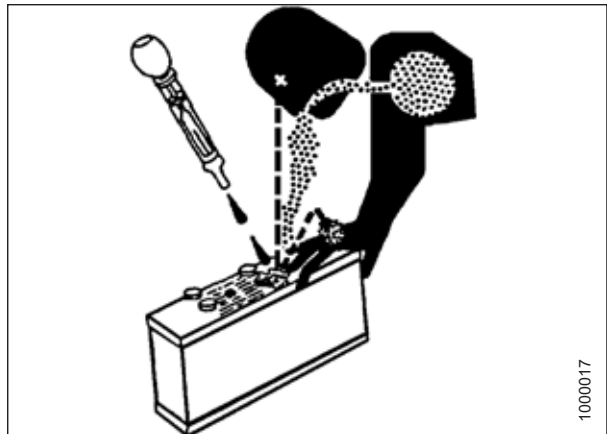

Figure 1.18: Safety around Batteries

1.8 Welding Precaution

IMPORTANT:

It is very important that correct procedures be followed when welding anything connected to the windrower. If procedures are not followed, it could result in severe damage to sensitive, expensive electronics. Even if complete failure of a module doesn't happen immediately, it is impossible to know what effect high current could have with regard to future malfunctions or shorter lifespan.

Due to the number of connectors, components to be welded should be removed from the windrower whenever possible rather than welded in place. When work needs to be completed on a header, disconnect the header completely from the windrower before welding. These same guidelines apply to plasma cutting, or any other high-current electrical operation performed on the machine.

The following items need to be disconnected:

- Negative battery terminals (A) (two connections)

IMPORTANT:

Always disconnect the battery terminals first, and reconnect them last.

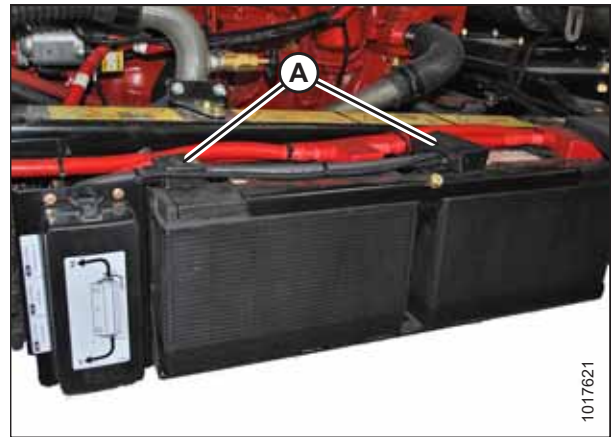

Figure 1.19: Negative Terminals

- Master controller (A)
Four connectors: P231, P232, P233, and P234
Location: Behind cab, near header lift/fan manifold

To disconnect the connectors, press the two outer tabs, and pull the connector away from master controller.

IMPORTANT:

When reconnecting these connectors, double-check that the connectors are fully seated into the master controller, and that the two locking tabs on each end of all four connectors have popped outward. If the tabs are not popped outward, the connector is not fully seated.

IMPORTANT:

Do **NOT** power up or operate the windrower until these connectors are locked into place.



Figure 1.20: Master Controller

SAFETY

- Firewall extension module (A)
Two connectors: P235 and P236

Location: Behind cab, near header lift/fan manifold

To disconnect the connectors, use a small 3–6 mm (1/8–1/4 in.) blade screwdriver to insert into the connector's locking tab. Gently pry upward (no more than 6 mm [1/4 in.]) to unlock the connector tab, and then pull the connector away from the module.



Figure 1.21: Firewall Extension Module

- Chassis extension module (A)
Two connectors: P247 and P248

Location: Under cab, inside left frame rail

To disconnect the connectors, use a small 3–6 mm (1/8–1/4 in.) blade screwdriver to insert into the connector's locking tab. Gently pry upward (no more than 6 mm [1/4 in.]) to unlock the connector tab, and then pull the connector away from the module.

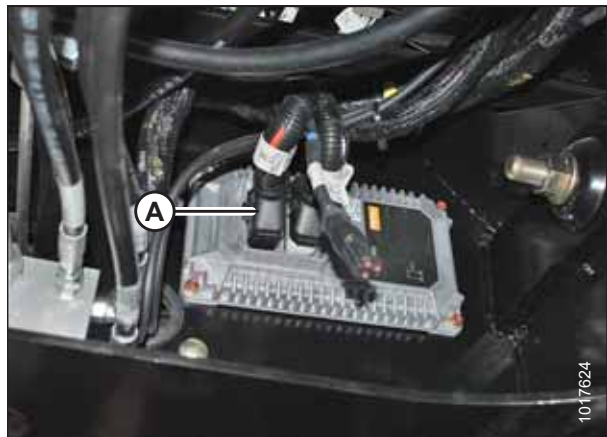

Figure 1.22: Chassis Extension Module

- Engine Control Module (ECM)
Two connectors for Cummins: P100 (A) and J1 Cummins Proprietary ECM Connector (B)

Location: On engine

To disconnect the connectors, pull the rubber boot off the cover, unlock the latch, and undo the main over-center latch. Remove strain relief bolts (C) so the connectors can be pulled away from the ECM.

IMPORTANT:

Be sure to disconnect both connectors. Note connector locations.

IMPORTANT:

Be sure to reconnect connectors in the proper locations. Do **NOT** cross connect.

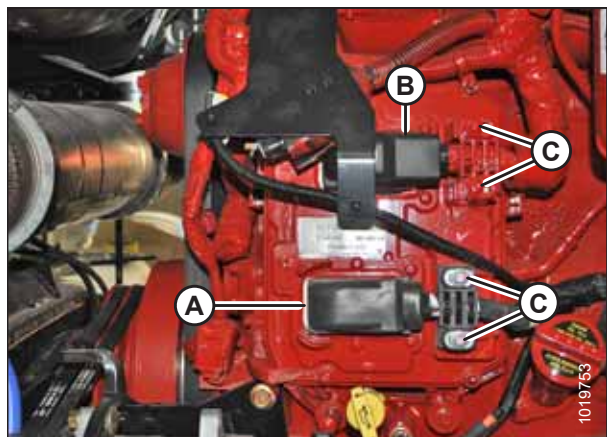

Figure 1.23: Engine Control Module

SAFETY

NOTE:

To disconnect the remaining circular Deutsch connectors, rotate the outer collar counterclockwise.

- Cab connectors (A)
Two round connectors: C1 and C2
Location: Under cab
- Roof connectors (A)
Four connectors: C10, C12, C13, and C14
Location: Under cab at base of left cab post
- Chassis relay module (A)
Three connectors: P240, P241, and P242
Location: Outside left frame rail near batteries

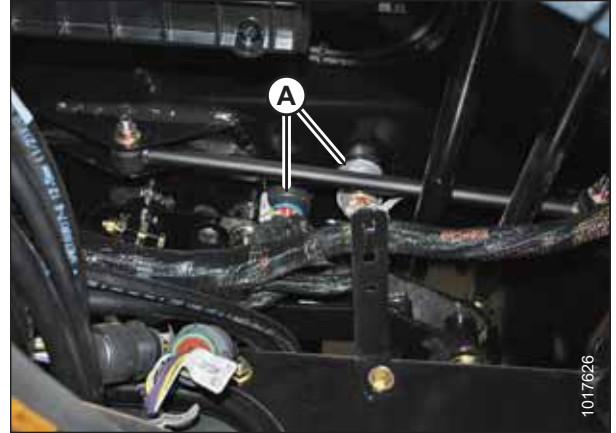

Figure 1.24: Cab Connectors

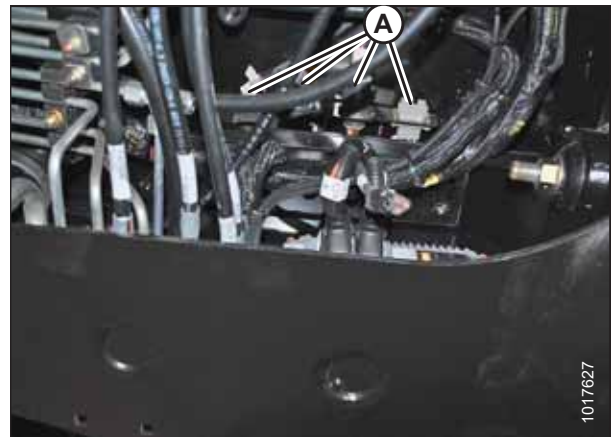

Figure 1.25: Roof Connectors



Figure 1.26: Chassis Relay Module

SAFETY

- Engine harness (A)
Two round connectors: C30 and C31
Location: Inside left frame rail, at rear of windrower

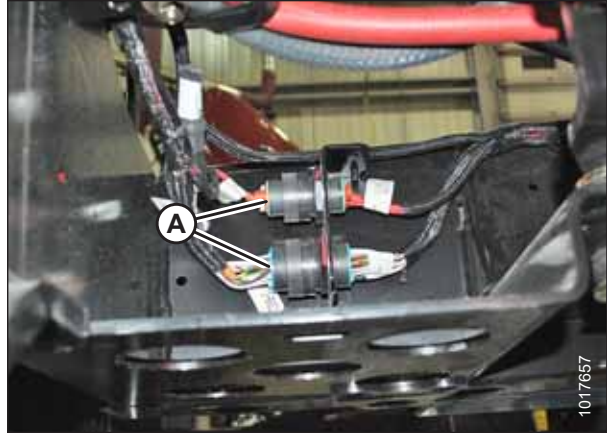

Figure 1.27: Engine Harness

- Air conditioning (A/C) box connectors (A)
Two connectors: C15 and C16
Location: Rear of A/C box



Figure 1.28: A/C Box Connectors

- Wheel motor connectors (A)
Two round connectors: C25 and C26
Location: Under center of frame, just behind front cross member

IMPORTANT:

To connect circular Deutsch connectors without bending the pins, align the plug with the receptacle before attempting to connect.

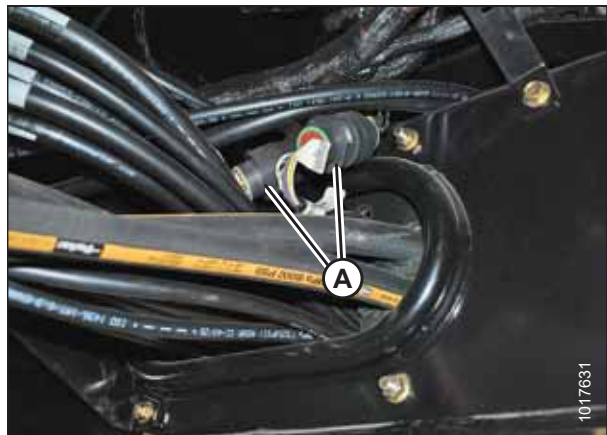

Figure 1.29: Wheel Motor Connectors

To align the connectors:

1. Observe the channel cuts and mating channel protrusions on the inner part of the circular walls of the connectors.
2. Face the mating connectors towards each other, and rotate connectors so that channels are aligned.
3. Press connectors together while turning the outer connector clockwise until collar locks.

1.9 Engine Safety



WARNING

Do NOT use aerosol starting aids such as ether. Such use could result in an explosion and personal injury.



CAUTION

- On initial start-up of a new, serviced, or repaired engine, always be ready to stop the engine to prevent an overspeed. Do this by shutting off the air and/or fuel supply to the engine.
- Do NOT bypass or disable automatic shutoff circuits. The circuits help prevent personal injury, and prevent engine damage. Contact your Dealer for repairs and adjustments.
- Inspect the engine for potential hazards.
- Before starting the engine, ensure no one is on, underneath, or close to the engine. Ensure that people clear the area.
- All protective guards and covers must be installed if the engine must be started to perform service procedures.
- To help prevent an accident, work around rotating parts carefully.
- If a warning tag is attached to the engine start switch or controls, do NOT start engine or move controls. Consult whoever attached the warning tag before starting the engine.
- Start the engine from the operator's station. Follow the procedure in the Starting Engine section of the operator's manual. Following the correct procedure will help prevent major damage to engine components and prevent personal injury.
- To ensure that the jacket water heater (if equipped) and/or lubricant oil heater (if equipped) is working correctly, check the water temperature gauge and/or oil temperature gauge during heater operation.
- Engine exhaust contains products of combustion, which can be harmful to your health. Always start and operate the engine in a well-ventilated area. If the engine is started in an enclosed area, vent exhaust to the outside.
- Engine exhaust gases become very hot during operation and can burn people and common materials. Stay clear of the rear of machine and avoid exhaust gases when engine is running.

NOTE:

If the engine will be operated in very cold conditions, then an additional cold-starting aid may be required.

1.9.1 High-Pressure Rail



WARNING

- Contact with high-pressure fuel may cause fluid penetration and burn hazards. High-pressure fuel spray may cause a fire hazard. Failure to follow these instructions may cause personal injury or death.
- Before disconnecting fuel lines or any other components under high-pressure between the fuel pump and high-pressure common rail fuel system, confirm that the fuel pressure is relieved.

1.9.2 Engine Electronics

WARNING

Tampering with electronic system installation or original equipment manufacturer (OEM) wiring installation is dangerous and could result in personal injury or death and/or engine damage.

WARNING

Electrical Shock Hazard. The electronic unit injectors use DC voltage. The engine control module (ECM) sends this voltage to the electronic unit injectors. **Do NOT** come in contact with the harness connector for the electronic unit injectors while engine is operating. Failure to follow this instruction could result in personal injury or death.

This engine has a comprehensive, programmable engine monitoring system. The ECM has the ability to monitor engine operating conditions. If conditions exceed the allowable range, the ECM will initiate immediate action.

The engine monitoring system can initiate the following actions:

- Warning
- Derate
- Shut down

Abnormalities in the following monitored conditions can limit engine speed and/or engine power:

- Engine coolant temperature
- Engine oil pressure
- Engine speed
- Intake manifold air temperature
- Diesel exhaust fluid (DEF) system performance
- Aftertreatment system performance

1.10 Safety Signs

Safety signs (decals) are usually yellow, and are placed on the machine where there is a risk of personal injury, or where the operator has to take extra precaution before operating controls. Operator manuals and technical manuals identify the location and meaning of all safety signs placed on the machine.

- Keep safety signs clean and legible at all times.
- Replace safety signs that are missing or illegible.
- If the original part on which a safety sign was installed is replaced, be sure the repair part displays the current safety sign.
- Replacement safety signs are available from your MacDon Dealer Parts Department.

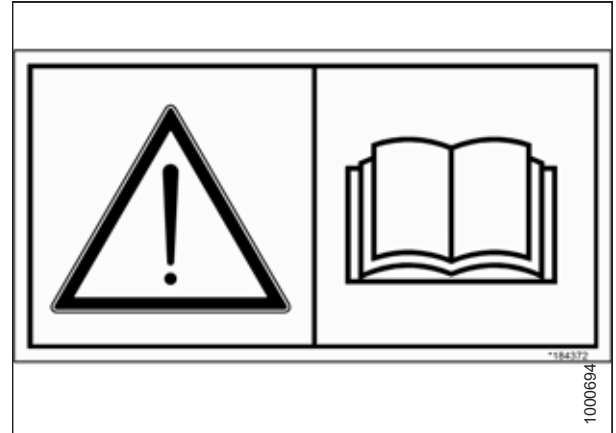

Figure 1.30: Operator's Manual Decal

1.10.1 Installing Safety Decals

1. Decide exactly where you are going to place the decal.
2. Clean and dry the installation area.
3. Remove the smaller portion of the split backing paper.
4. Place the decal in position and slowly peel back the remaining paper, smoothing the decal as it is applied.
5. Prick small air pockets with a pin and smooth out.

1.11 Safety Sign Locations

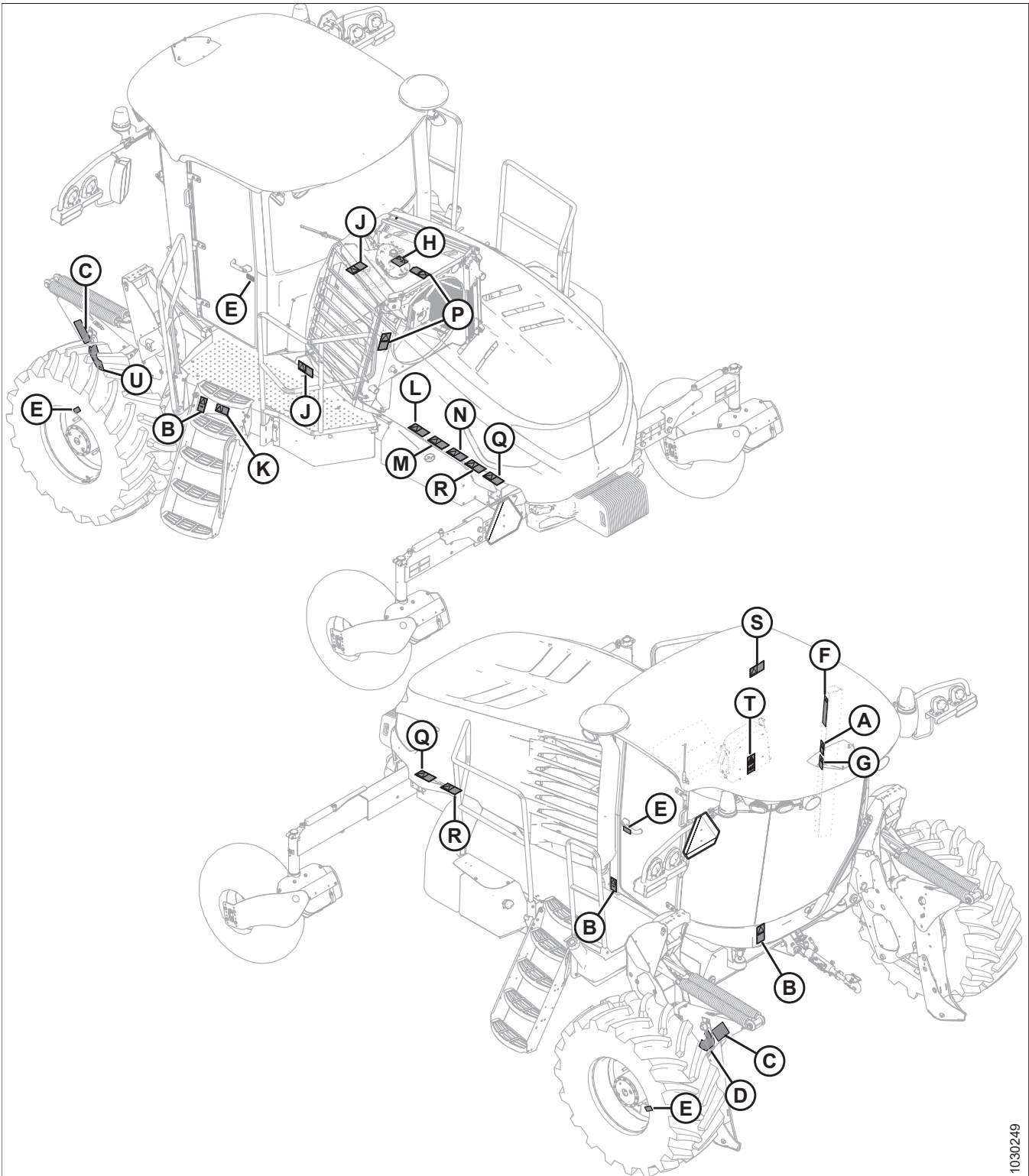

Figure 1.31: Safety Sign Locations

SAFETY

Table 1.1 Safety Sign Locations

Ref	MD Part Number	Safety Sign Description
A	166234	Decal – Warning (training seat and seat belts)
B	166425	Decal – Danger
C	306181	Decal – Header lock, 2 panel (both sides)
D	306180	Decal – Header lock, 2 panel (RH)
E	166454	Decal – Read manual
F	166457	Decal – Warning, read manual steering service
G	166463	Decal – Transport
H	166824	Decal – Fill rate
J	166832	Decal – High pressure fluid
K	166829	Decal – Caution, balance
L	166834	Decal – Warning, starter jump
M	166835	Decal – Warning, battery explode
N	166836	Decal – Warning, battery burn
P	166837	Decal – Danger, fan
Q	166838	Decal – Warning, hot surface
R	166839	Decal – Warning, belt
S	166843	Decal – Steering control
T	167502	Decal – Warning, pinch hazard
U	306180	Decal – Header lock, 2 panel (LH)

NOTE:

For a more detailed illustration and description of safety signs, refer to [1.12 Understanding Safety Signs, page 18](#).

1.12 Understanding Safety Signs

MD #166234

Run-over hazard

DANGER

- The training seat is provided for an experienced Operator of the machine when a new Operator is being trained.
- The training seat is **NOT** intended as a passenger seat or for use by children.
- Use the seat belt whenever operating the machine or riding as a trainer.
- Keep all other riders off the machine.



Figure 1.32: MD #166234

MD #166425

Run-over hazard

DANGER

To prevent machine runaway:

- Stop the engine and remove the key from the ignition before performing maintenance or service on the steering linkage or neutral interlock system.
- Read the windrower and header manuals for inspection and maintenance instructions.



Figure 1.33: MD #166425

SAFETY

MD #166454

General hazard pertaining to machine operation and servicing

DANGER

To prevent injury or death from improper or unsafe machine operation:

- Read the operator's manual and follow all safety instructions.
- Do **NOT** allow untrained persons to operate the machine.
- Review safety instructions with all Operators every year.
- Ensure that all safety signs are installed and legible.
- Make certain everyone is clear of the machine before starting the engine and during operation.
- Keep riders off the machine.
- Keep all shields in place and stay clear of moving parts.
- Disengage the header drive, put the transmission in Neutral, and wait for all movement to stop before leaving the operator's position.
- Stop the engine and remove the key from the ignition before servicing, adjusting, lubricating, cleaning, or unplugging the machine.
- Engage safety locks to prevent lowering of the header or reel before servicing in the raised position.
- Use a slow moving vehicle emblem and flashing warning lights when operating on roadways unless prohibited by law.



Figure 1.34: MD #166454

SAFETY

MD #166457

General hazard pertaining to machine operation and servicing

DANGER

To prevent injury or death from improper or unsafe machine operation:

- Read the operator's manual and follow all safety instructions.
- Do **NOT** allow untrained persons to operate the machine.
- Review safety instructions with all Operators every year.
- Ensure that all safety signs are installed and legible.
- Make certain everyone is clear of the machine before starting the engine and during operation.
- Keep riders off the machine.
- Keep all shields in place and stay clear of moving parts.
- Disengage the header drive, put the transmission in Neutral and wait for all movement to stop before leaving the operator's position.
- Stop the engine and remove the key from the ignition before servicing, adjusting, lubricating, cleaning, or unplugging the machine.
- Engage safety locks to prevent lowering of the header or reel before servicing in the raised position.
- Use a slow moving vehicle emblem and flashing warning lights when operating on roadways unless prohibited by law.

Run-over hazard

DANGER

- The machine will move if the steering wheel is turned while the engine is running.
- Steering response is opposite to what is normally expected when backing up. Turn bottom of steering wheel in direction you want to go.
- Always move the ground speed lever to the slow end of the range before shifting the high-low speed control.
- To prevent machine runaway: stop the engine and remove the key from the ignition before servicing, adjusting, lubricating, cleaning, unplugging the machine, or before performing maintenance or service on steering linkage or neutral interlock system.
- Read the windrower and header manuals for inspection and maintenance instructions.

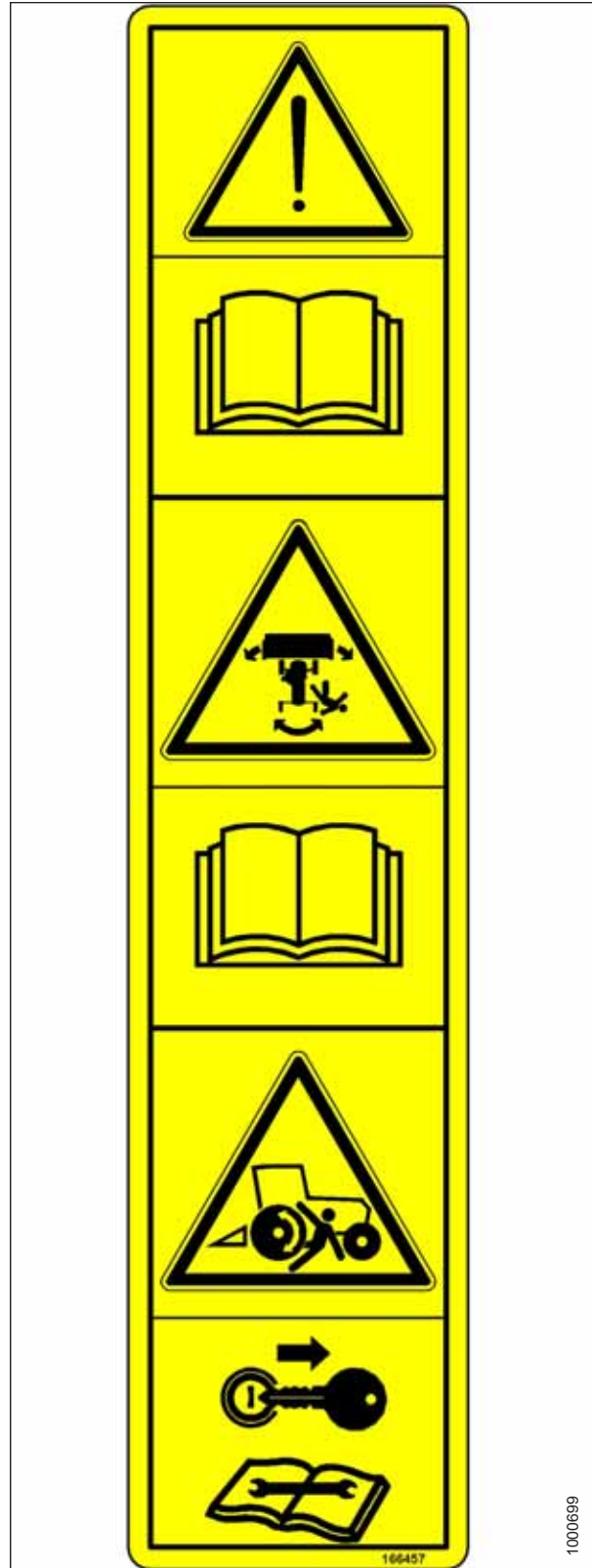

Figure 1.35: MD #166457

SAFETY

MD #166463

Collision hazard

DANGER

To prevent injury or death from a collision between the windrower and other vehicles when driving the windrower on public roadways:

- Obey all highway traffic regulations in your area. Use pilot vehicles front and rear of windrower if required by law.
- Use a slow moving vehicle emblem and flashing warning lights unless prohibited by law.
- If the width of the attached header impedes other vehicle traffic, remove header and install a MacDon approved weight box. For instructions, refer to the windrower and header operator's manuals for safe procedure to tow header.



Figure 1.36: MD #166463

MD #166824

Hot fluid spray hazard and fluid fill rate information

CAUTION

To prevent injury:

- Fluid is under pressure and may be hot.
- Do **NOT** remove the fluid fill cap when the engine is hot.
- Allow the engine to cool down before opening the fluid fill cap.
- Fill the tank slowly. Do **NOT** exceed 11 L/min (3 gpm)



Figure 1.37: MD #166824

SAFETY

MD #166829

Loss of control hazard

DANGER

To prevent serious injury or death from loss of control:

- It is essential that the machine be equipped such that weights are within the specified limits.
- Weight on the tail wheels should be greater than 1179 kg (2600 lb.) with the windrower positioned in the cab-forward direction.
- Ensure recommended rear ballast kits are installed for proper machine balance. When operating in hilly conditions, additional rear ballast kits may be required.

MD #166832

High-pressure oil hazard

WARNING

To prevent serious injury, gangrene, or death:

- High-pressure oil can easily puncture skin, and can cause serious injury, gangrene, or death.
- Do **NOT** go near leaks.
- Do **NOT** use fingers or skin to check for leaks.
- Lower the load or relieve hydraulic pressure before loosening fittings.
- If injured, seek emergency medical help. Immediate surgery is required to remove oil.

MD #166834

Run-over hazard

DANGER

To prevent machine runaway:

- Do **NOT** start the engine in gear.
- Starting in gear can kill.
- Do **NOT** start the engine by shorting across starter or the starter relay terminals. The machine will start with the drive engaged and move if starting circuitry is bypassed.
- Start engine only from the operator's seat. Do **NOT** try to start the engine with someone under or near machine.



Figure 1.38: MD #166829



Figure 1.39: MD #166832



Figure 1.40: MD #166834

SAFETY

MD #166835

Battery explosion hazard

WARNING

To prevent serious bodily injury caused by explosive battery gases:

- Keep sparks and flames away from the battery and do **NOT** connect boosting or charging cables incorrectly.
- Refer to operator's manual for battery boosting and charging procedures.



Figure 1.41: MD #166835

MD #166836

Battery acid hazard

WARNING

To prevent injury from corrosive and poisonous battery acid:

- Wear protective clothing and personal protective devices when handling battery acid.
- Acid can severely burn your body and clothing.



Figure 1.42: MD #166836

SAFETY

MD #166837

Rotating fan hazard

WARNING

To prevent injury:

- Do **NOT** operate engine with engine hood open.
- Stop the engine and remove the key before opening the engine hood.

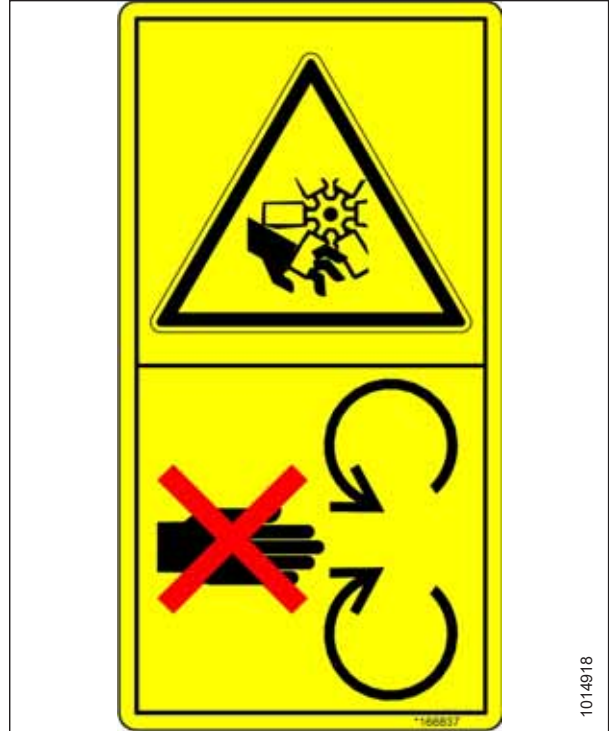

Figure 1.43: MD #166837

MD #166838

Hot surface hazard

CAUTION

To prevent injury:

- Keep a safe distance from hot surfaces.

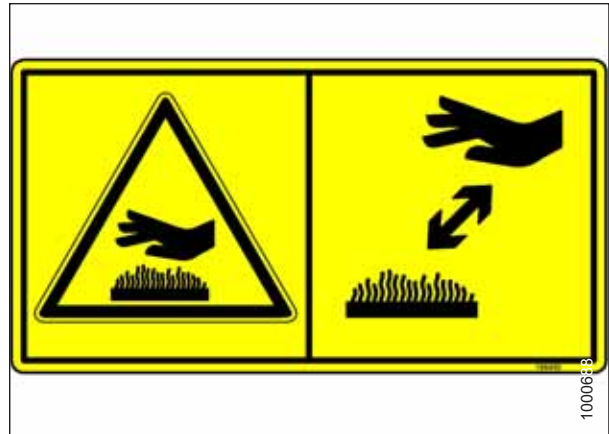

Figure 1.44: MD #166838

SAFETY

MD #166839

Hand and arm entanglement hazard

WARNING

To prevent injury:

- Do **NOT** operate without shields in place.
- Stop the engine and remove the key before opening the shield.



Figure 1.45: MD #166839

MD #166843

Loss of control hazard

DANGER

To prevent serious injury or death from loss of control:

- Do **NOT** make abrupt changes in steering direction.
- Anticipate turns by slowing down well in advance.
- Do **NOT** rapidly accelerate or decelerate while turning.

When travelling up steep slopes:

- Reduce speed and lower header.
- Move ground speed lever to slow end of range.
- Shift high-low speed control to low range.

With the header removed, steering control is reduced if weight is not added to the drive wheels. If you must drive the windrower without a header or MacDon weight system:

- Operate in low-speed range.
- Avoid slopes.
- Do **NOT** tow a header.

If control of machine is lost, immediately pull ground speed lever to neutral.

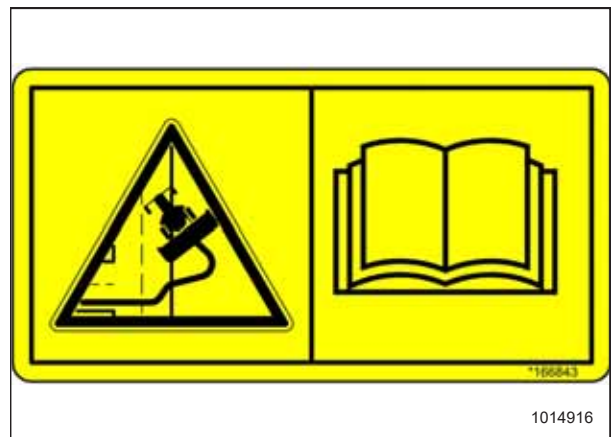

Figure 1.46: MD #166843

SAFETY

MD #167502

Pinch point hazard

CAUTION

To prevent injury:

- Do **NOT** reach into the pinch area



Figure 1.47: MD #167502

MD #306180/306181

Header crushing hazard

DANGER

To prevent injury or death from fall of raised header:

- Fully raise the header, stop the engine, remove the key from the ignition, and engage the safety props before going under the header.

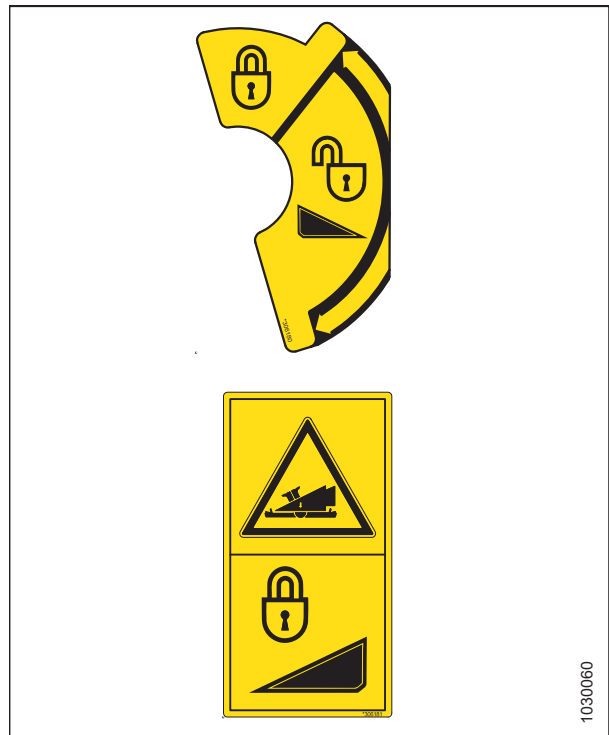

Figure 1.48: MD #306180/306181

Chapter 2: Product Overview

2.1 Definitions

The following terms and acronyms may be used in this manual:

Term	Definition
A Series Header	MacDon A40D, A40DX, and Grass Seed auger headers
API	American Petroleum Institute
ASTM	American Society of Testing and Materials
Bolt	A headed and externally threaded fastener that is designed to be paired with a nut
Cab-forward	Windrower operation with Operator and cab facing in direction of travel
Center-link	A hydraulic cylinder link between the header and machine used to change header angle
CGVW	Combined gross vehicle weight
D1X Series Header	MacDon D115X, D120X, and D125X rigid draper headers for M1 Series Windrowers
D1XL Series Header	MacDon D130XL, D135XL, D140XL, and D145XL rigid draper headers for M1 Series Windrowers
DDD	Double-draper drive
DEF	Diesel exhaust fluid; also called AdBlue in Europe, and AUS 32 in Australia
DEF supply module	Pump that supplies diesel exhaust fluid through system
DM	Dosing module
DK	Double knife
DKD	Double-knife drive
DOC	Diesel oxidation catalyst
DRT	Aftertreatment decomposition tube
DWA	Double Windrow Attachment
ECM	Engine control module
EEC	Eco engine control
Engine-forward	Windrower operation with Operator and engine facing in direction of travel
FFFT	Flats from finger tight
Finger tight	Finger tight is a reference position where sealing surfaces or components are making contact with each other, and fitting has been tightened to a point where fitting is no longer loose
GSL	Ground speed lever
GSS	Grass Seed
GVW	Gross vehicle weight
Hard joint	A joint made with use of a fastener where joining materials are highly incompressible
Header	A machine that cuts and lays crop into a windrow and is attached to a windrower
Hex key	A tool of hexagonal cross-section used to drive bolts and screws that have a hexagonal socket in head (internal-wrenching hexagon drive); also known as an Allen key and various other synonyms

PRODUCT OVERVIEW

Term	Definition
HDS	Hydraulic deck shift
hp	Horsepower
HPT display	Harvest Performance Tracker display module on an M1 Series Windrower
JIC	Joint Industrial Council: A standards body that developed standard sizing and shape for original 37° flared fitting
Knife	A cutting device which uses a reciprocating cutter (also called a sickle)
MDS	Mechanical deck shift
M1 Series	MacDon M1170 and M1240 Windrowers
n/a	Not applicable
NPT	National Pipe Thread: A style of fitting used for low-pressure port openings. Threads on NPT fittings are uniquely tapered for an interference fit
Nut	An internally threaded fastener that is designed to be paired with a bolt
ORB	O-ring boss: A style of fitting commonly used in port openings on manifolds, pumps, and motors
ORFS	O-ring face seal: A style of fitting commonly used for connecting hoses and tubes. This style of fitting is also commonly called ORS, which stands for O-ring seal
PARK	The slot opposite the NEUTRAL position on operator's console of M1 Series windrowers
R Series	MacDon R80 and R85 Rotary Disc Headers for windrowers
R1 SP Series	MacDon R113 and R116 Rotary Disc Headers for windrowers
R2 SP Series	MacDon R216 Rotary Disc Headers for windrowers
RoHS (Reduction of Hazardous Substances)	A directive by the European Union to restrict use of certain hazardous substances (such as hexavalent chromium used in some yellow zinc platings)
rpm	Revolutions per minute
SAE	Society of Automotive Engineers
SCR	Selective catalytic reduction
Screw	A headed and externally threaded fastener that threads into preformed threads or forms its own thread into a mating part
SDD	Single-drawer drive
SK	Single knife
SKD	Single-knife drive
Soft joint	A joint made with use of a fastener where joining materials are compressible or experience relaxation over a period of time
spm	Strokes per minute
Tension	Axial load placed on a bolt or screw, usually measured in Newtons (N) or pounds (lb.)
TFFT	Turns from finger tight
Torque	The product of a force X lever arm length, usually measured in Newton-meters (Nm) or foot-pounds (lbf-ft)
Torque angle	A tightening procedure where fitting is assembled to a precondition (finger tight) and then nut is turned farther a number of degrees to achieve its final position

PRODUCT OVERVIEW

Term	Definition
Torque-tension	The relationship between assembly torque applied to a piece of hardware and axial load it induces in bolt or screw
ULSD	Ultra-low sulphur diesel
Washer	A thin cylinder with a hole or slot located in the center that is to be used as a spacer, load distribution element, or locking mechanism
Windrower	Power unit for a header
WOT	Wide open throttle

PRODUCT OVERVIEW

2.2 Specifications

Specifications and design are subject to change without notice or obligation to revise previously sold units.

Engine			
Type	Cummins QSB-6.7L CM2350, six cylinder tier 4 final, turbo diesel (B20 bio-diesel approved)		
Displacement	6.7 L (409 cu.in.)		
Power	Rated	185 kW (248 hp) @ 2200 rpm	
	Peak	196 kW (263 hp) @ 2000 rpm	
Maximum rpm (no load)	2300		
Idle rpm	1000		
Electrical System			
Battery (2)	12 Volt, maximum dimension – 334 x 188 x 232 mm (13 x 6.81 x 9.43 in.). Group rating 29H or 31A. Heavy duty/off road/vibration resistant		
Minimum CCA per battery (cold cranking amps)	750		
Alternator	200 amp		
Egress lighting	Standard		
Starter	Wet type		
Lights	Base cab ¹	12 halogen: 4 road, 8 work (2 also used for egress)	
Traction Drive			
Type	Hydrostatic, infinitely variable motors via electric shift		
Speed	Field	0–29 km/h (18 mph)	
	Reverse	9.6 km/h (6 mph)	
	Transport – Engine-forward	0–44 km/h (27.5 mph) (Standard drive wheel)	
		0–34.6 km/h (21.5 mph) (High torque drive wheel)	
Transmission	Type	2 piston pumps – 1 per drive wheel	
	Displacement	44 cc (2.65 cu.in.)	
	Flow	167 L/min (40 U.S. gpm)	
Final drive	Type	Planetary gearbox	
	Ratio	Standard: 27.8 : 1, High Torque, 36.82 : 1	
System Capacities			
Fuel tank	518 L (137 U.S. gallons)		
Diesel exhaust fluid tank	28 L (7.5 U.S. gallons)		
Coolant	33 L (8.72 U.S. gallons)		
Hydraulic reservoir	60 L (15.8 U.S. gallons)		

1. Windrower Lighting Upgrade (MD #B6889) can be installed on the base cab, replacing halogen lights with LED lights.

PRODUCT OVERVIEW

Header Drive		
Knife/disc	Pump	Piston, 105.5 cc (6.44 cu. in.)
	Max pressure	41,369 kPa (6000 psi)
	Flow	0–272.5 L/min (72 gpm)
Reel	Pump	Gear, 25.2 cc (1.54 cu. in.)
	Max pressure	23,993 kPa (3480 psi)
	Flow	75.7 L/min (20 gpm)
Draper	Pump	Gear, 19.3 cc (1.18 cu. in.)
	Max pressure	23,993 kPa (3480 psi)
	Flow	57 L/min (15 gpm)
Charge system	Pump	Gear, 32.4 cc (1.98 cu. in.)
	Max pressure	3.4 MPa (500 psi)
	Flow	44 L/min (25 gpm)
Lift/Fan Drive		
Pump		Piston, 60 cc (3.66 cu. in.)
Max pressure		22,063 kPa (3200 psi)
Flow		0–170.3 L/min (45 gpm)
Header Lift/Tilt		
Type		Hydraulic double acting cylinders
Maximum lift capacity		3810 kg (8400 lb.)
Header Float		
Adjustment		Fully in-cab adjustable
Automatic		Memory for 3 float settings (deck shift positions on draper)
Options		External booster spring (1 or 2 per side)
Base Cab		
Suspension		4 point spring/shock
Dimensions	Width	1767 mm (69.6 in.)
	Depth	1735 mm (68.3 in.)
	Height	1690 mm (66.5 in.)
Seat	Operator	Cloth, adjustable air ride suspension, seat belt
	Training	Cloth, folding, cab mounted, seat belt
Windshield wiper	Front	990 mm (39 in.) blade, washer equipped
	Rear	560 mm (22 in.) blade, washer equipped
Heater		11.10 kW (37,900 Btu/hr)
Air conditioning		8.73 kW (29,800 Btu/hr)
Electrical outlets	12 V DC	6
	USB	2

PRODUCT OVERVIEW

Mirrors		Two outside (field use), one inside (engine-forward transport)
Radio		Two speakers, antenna, microphone and AM/FM/CD/USB/Bluetooth® radio factory installed
Window shades		Front and rear
Deluxe Cab Package (in addition to Base Cab)		
Seat	Operator	Leather, adjustable air ride suspension, seat belt, heated/cooled, lateral isolation, adjustable front cushion
	Training	Leather, folding, cab mounted, seat belt
Mirrors		Two power mirrors outside (field use)
Lights	High Performance Lighting	12 lights: 4 halogen road, 8 LED work lights
System Monitoring		
Display		178 mm (7 in.) LCD
Speeds		Ground (mph or km/h), engine (rpm), knife (spm), reel (rpm or mph / km/h), conveyor (rpm or mph / km/h), cooling fan (rpm)
Pressures		Knife (psi or MPa), reel (psi or MPa), conveyor (psi or MPa), supercharge (psi or MPa)
Header position	Platform	Height, angle, float
	Reel	Height, fore-aft
Engine parameters		Fuel consumption, load
Tire Options		
Drive	Bar	600/65R28
	Turf	580/70R26
Caster	Suspended	16.5L-16.1 with independent suspension
	Mud	11x16 with single-sided caster (unsuspended)
Frame and Structure		
Dimensions		Refer to 2.3 Windrower Dimensions, page 33
Frame to ground (crop clearance)		1160 mm (45.7 in.)
Walking beam maximum width		3856 mm (151.8 in.) with 3422 mm (134.7 in.) crop clearance
Weight ²	Base ³	6078 kg (13,400 lb.)
	Max GVW	10,660 kg (23,500 lb.)
	Max CGVW	11,794 kg (26,000 lb.)
Header compatibility	Draper	D1XL Series, D1X Series Draper Header
	Rotary	4.9 m (16 ft.) R85, R113, R216 Rotary Disc Header
	Auger	A40DX Series

2. Weights do not include options.

3. Weight with 600-65R28 bar tires, no fuel/DEF. Hydraulic oil and coolant included in weight.

2.3 Windrower Dimensions

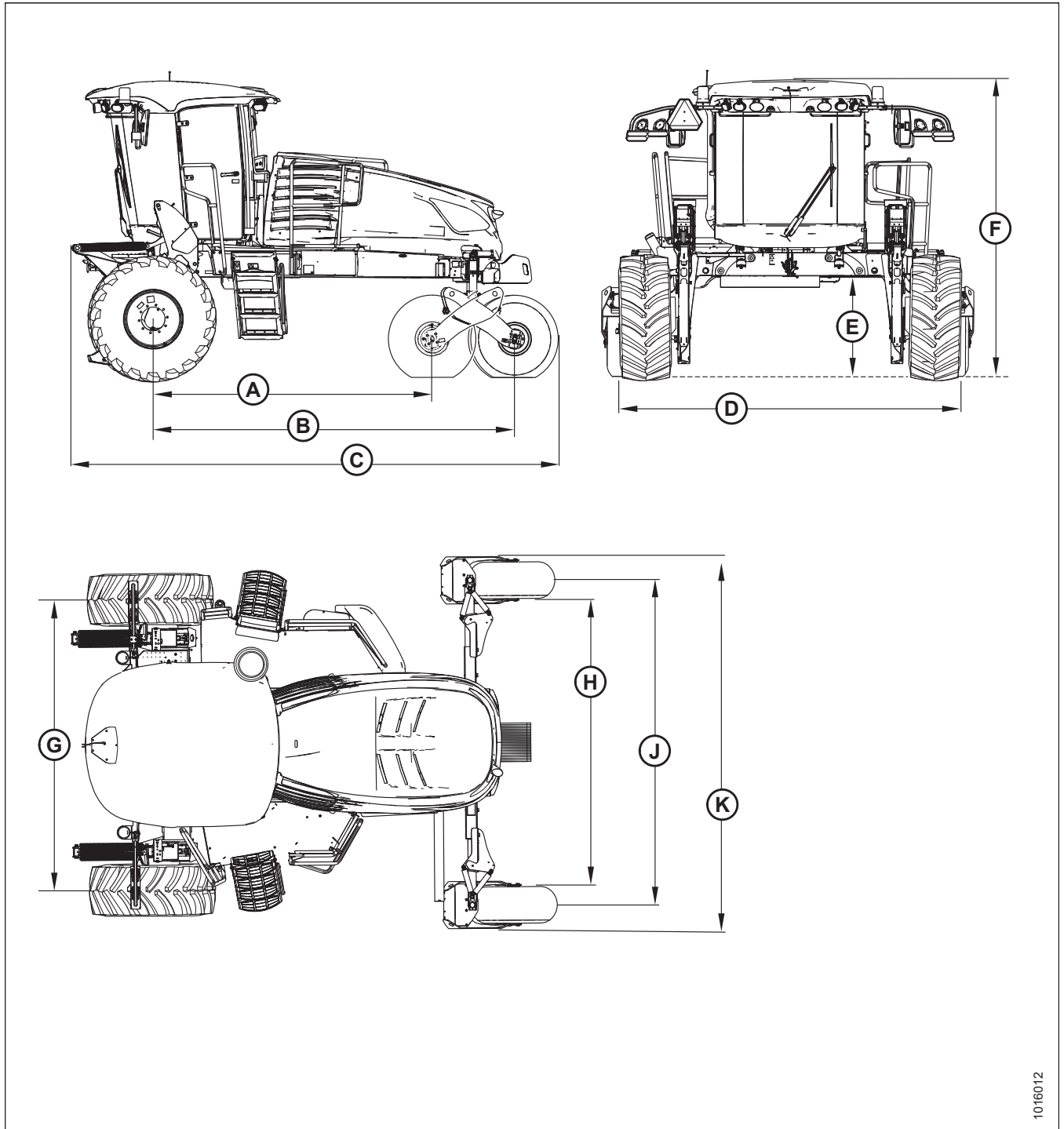

Figure 2.1: Windrower Dimensions

A - 3304 mm (130 3/32 in.)
 D - 4070 mm (160 1/4 in.)
 G - 3449 mm (135 13/16 in.)
 K - 4415 mm (173 13/16 in.)

B - 4290 mm (168 7/8 in.)
 E - 1160 mm (45 11/16 in.)
 H - 3422 mm (134 3/4 in.)

C - 5752 mm (226 7/16 in.)
 F - 3480 mm (137 1/32 in.)
 J - 3856 mm (151 13/16 in.) (Max)

1016012

2.4 Component Location

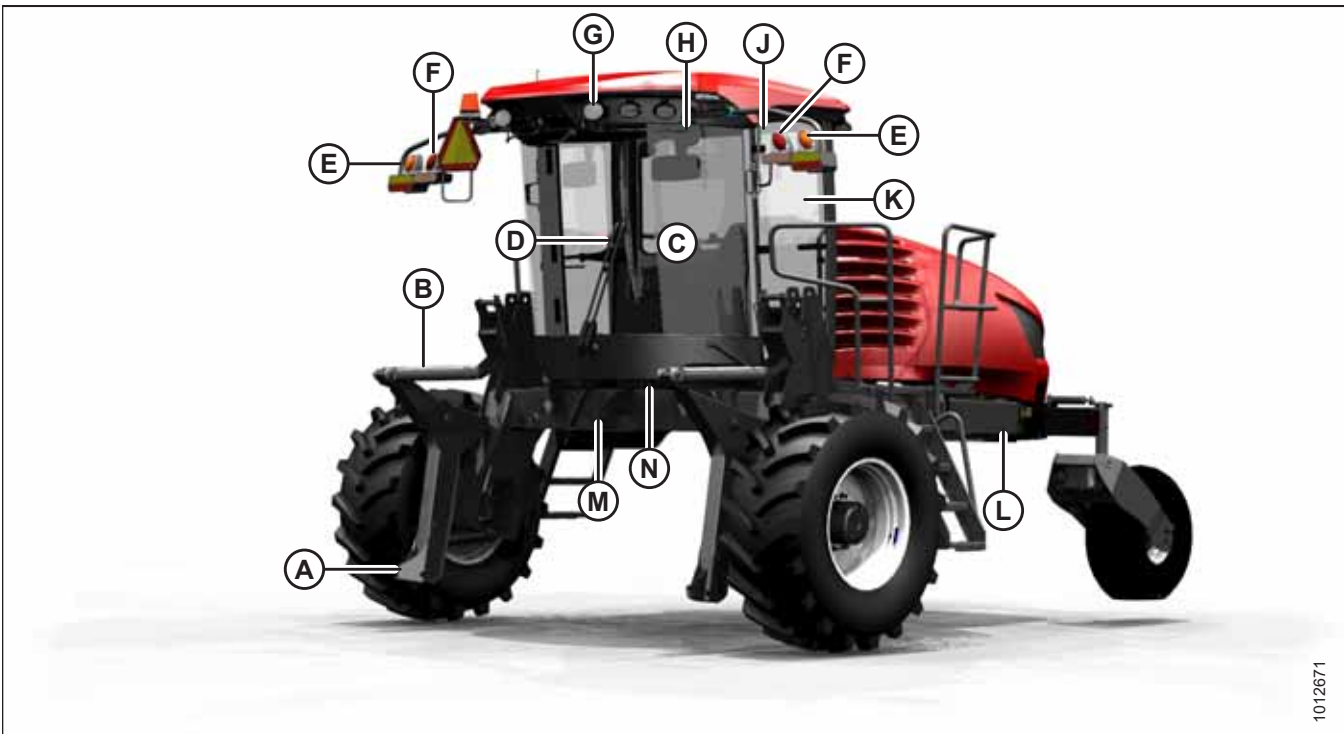

1012671

Figure 2.2: Front Cab-Forward View

A - Header Lift Leg
 D - Windshield Wiper
 G - Field/Road Lights⁴
 K - Door
 N - Horn

B - Header Float Springs
 E - Turn Signal / Hazard Lights
 H - Handholds
 L - Maintenance Platform

C - Operator's Station
 F - Tail lights Engine-Forward
 J - Mirror
 M - Center-Link

4. Standard cabs have halogen lights; deluxe cabs have LED lights.

PRODUCT OVERVIEW



Figure 2.3: Rear Cab-Forward View

A - Caster Wheel
D - Engine Compartment Hood
G - Turn Signal / Hazard Lights
K - Door
N - Precleaner

B - Walking Beam
E - Windshield Wiper
H - Field/Road Lights
L - Drive Wheel
P - Beacons

C - Taillights – Cab-Forward
F - Field Lights⁵
J - Mirror
M - Maintenance Platform
Q - Anti-Shimmy Dampeners

5. Standard cabs have halogen lights; deluxe cabs have LED lights.

Chapter 3: Operator's Station

The operator's station is designed for operating the windrower in cab-forward mode (working mode) or in engine-forward mode (transport mode). The operator's station, which includes the seat, console, and steering column, pivots 180° so that the Operator maintains access to the windrower controls and gauges regardless of the direction of travel.

3.1 Console

The console contains controls to operate the windrower, as well as amenities for the Operator.

The console position is adjustable to suit each particular Operator. Operable parts of the console include:

- Ignition (A)
- Harvest Performance Tracker (HPT) Display (B)
- Header Controls (C)
- Ground Speed Lever (GSL) (D)
- Throttle (E)

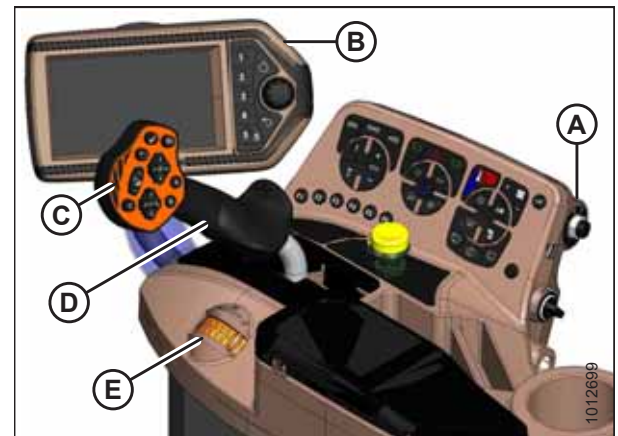

Figure 3.1: Console

1. Adjust fore-aft and height as follows:
 - a. Pull lever (A) and slide the console fore or aft to the desired position.
 - b. Release the lever to lock the console.

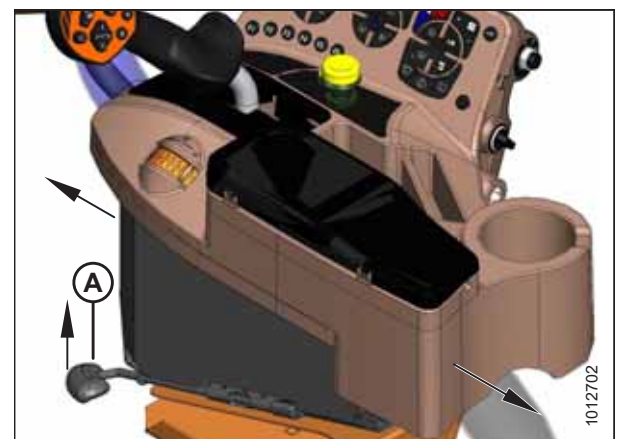

Figure 3.2: Console Fore-Aft/Height

OPERATOR'S STATION

2. Adjust only fore-aft as follows:
 - a. Loosen nuts (A) under the console.
 - b. Move the console as required.
 - c. Tighten nuts (A).

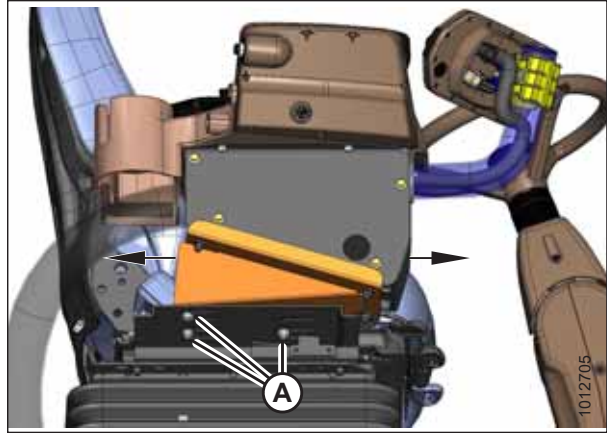

Figure 3.3: Console Fore-Aft

3.2 Operator Presence System

The Operator Presence System is a safety feature designed to deactivate selected systems or sound an alarm when the Operator is not seated at the operator's station.

These systems include:

- Header drive; refer to [3.2.1 Header Drive, page 39](#)
- Engine and transmission; refer to [3.2.2 Engine and Transmission, page 39](#)

3.2.1 Header Drive

- Requires the Operator to be in the seat in order to engage the header drive.
- Power is maintained to the header drive for 5 seconds after the Operator leaves the seat, and then the header shuts down.
- After the header has shut down automatically, the HEADER ENGAGE switch must be moved to the OFF position and back to the ON position to restart the header.

3.2.2 Engine and Transmission

- The engine will **NOT** start when the HEADER ENGAGE switch is engaged.
- The engine will shut down when the windrower is moving at 8 km/h (5 mph) or less, and the Operator leaves the seat, and the transmission is not locked in NEUTRAL. The Harvest Performance Tracker (HPT) will display NO OPERATOR DETECTED and ENGINE SHUT DOWN 5...4...3...2...1...0 accompanied by a steady tone. At 0, the engine shuts down.
- If the windrower is moving faster than 8 km/h (5 mph), and the Operator leaves the seat, after 2 seconds an alarm will sound and the HPT will display NO OPERATOR.
- When the seat is in between cab-forward and engine-forward positions, the engine will shut down if the transmission is not locked in the NEUTRAL position. The HPT will display LOCK SEAT BASE until the seat base is locked into position.

3.3 Operator's Seat Adjustments

The operator's seat can be adjusted in several ways to make the Operator more comfortable.

Refer to the following sections for a description and the location of each adjustment. Some seat features are only available with the deluxe cab option.

3.3.1 Armrest

The standard and deluxe seats are equipped with one armrest.

Raise the armrest for easier access to the seat.

Lower the armrest after the seat belt is buckled.

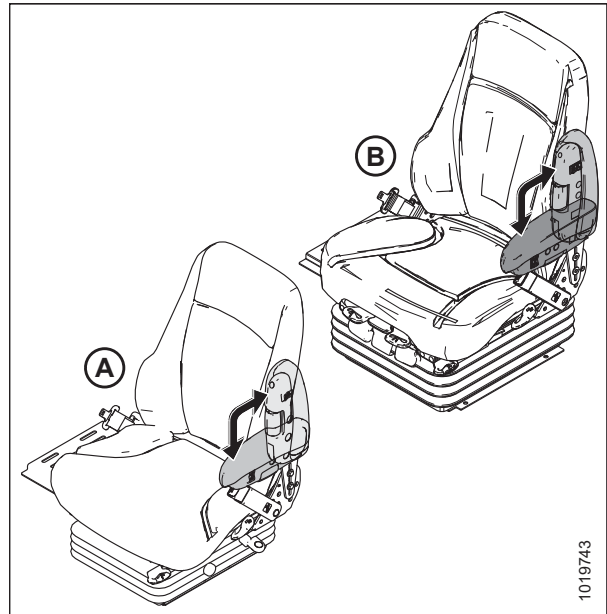

Figure 3.4: Operator's Seat Armrest

A - Standard Seat

B - Deluxe Seat

3.3.2 Armrest Angle

Use controls to adjust angle of armrest.

- Rotate knob (A) clockwise to increase the armrest angle.
- Rotate knob (A) counterclockwise to decrease the armrest angle.



Figure 3.5: Operator's Seat Armrest Angle Controls

3.3.3 Suspension and Height

Use controls to adjust the height and stiffness of the seat suspension.

- Press upper switch (A) to increase seat stiffness and height.
- Press lower switch (A) to decrease seat stiffness and height.

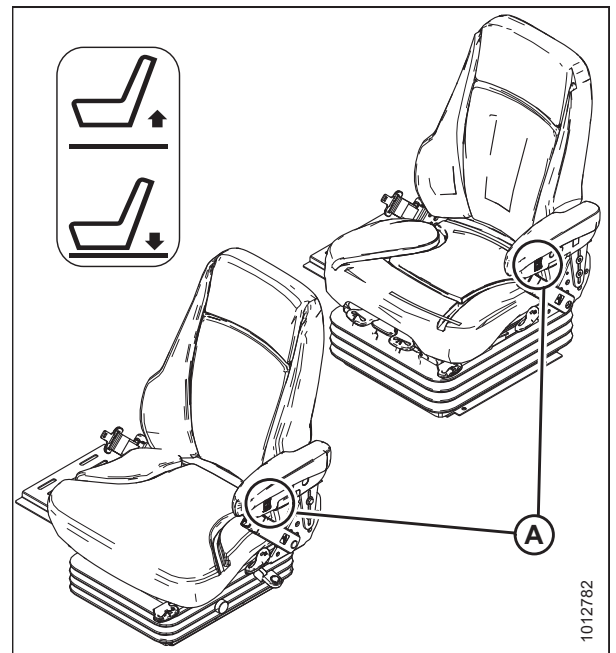

Figure 3.6: Operator's Seat Suspension and Height Controls

3.3.4 Fore-Aft Slide Control

Use controls to adjust the seat's fore-aft position.

1. Pull lever (A) up to release.
2. Move the seat forward or rearward.
3. Release lever (A).

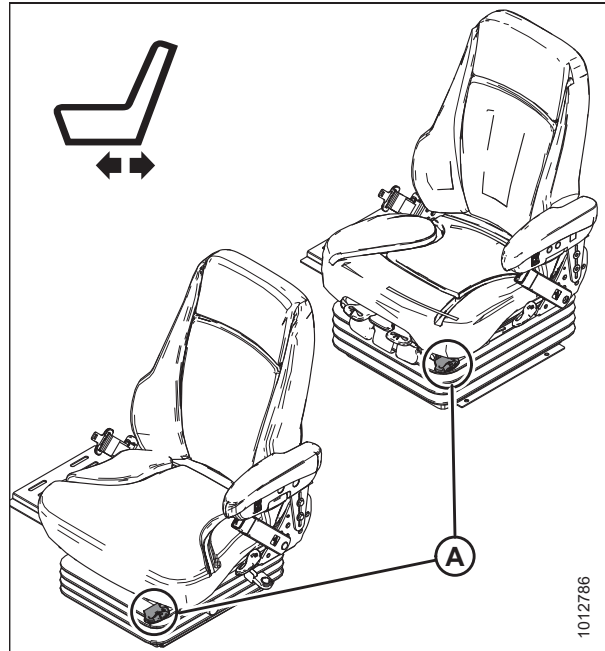

Figure 3.7: Operator's Seat Fore-Aft Position Controls

3.3.5 Fore-Aft Isolator Control

Use controls to lock the seat's fore-aft isolator.

- Push lever (A) down to lock
- Pull lever (A) up to unlock

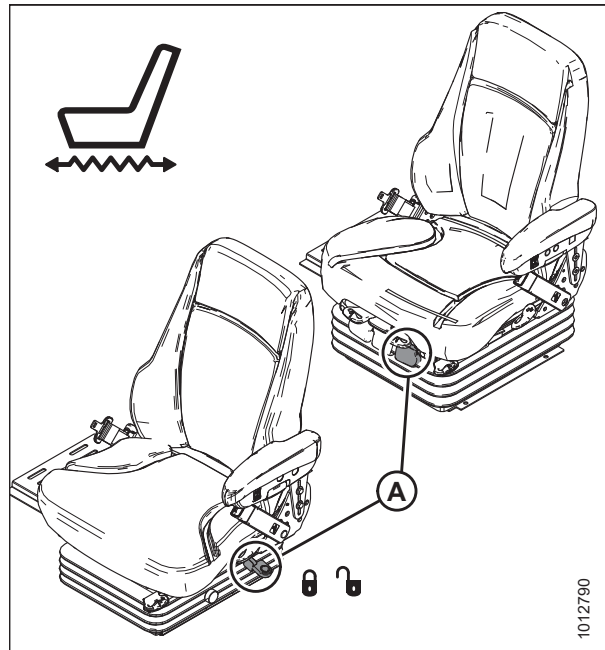

Figure 3.8: Operator's Seat Fore-Aft Isolator Controls

3.3.6 Tilt

Use controls to adjust the seat's tilt.

1. Pull lever (A) up to release.
2. Position the seat back as desired.
3. Release lever (A).

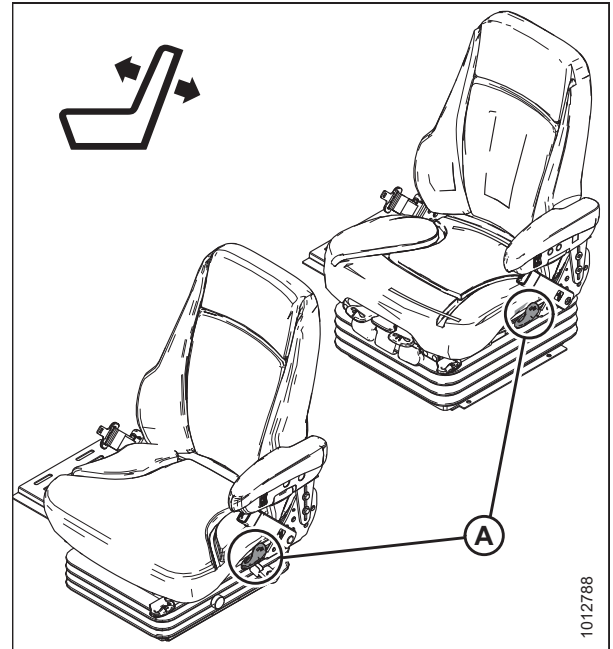

Figure 3.9: Operator's Seat Tilt Controls

3.3.7 Lumbar Support

Use controls to adjust the stiffness of the seat's back.

- Rotate knob (A) clockwise to increase lumbar support.
- Rotate knob (A) counterclockwise to decrease lumbar support.

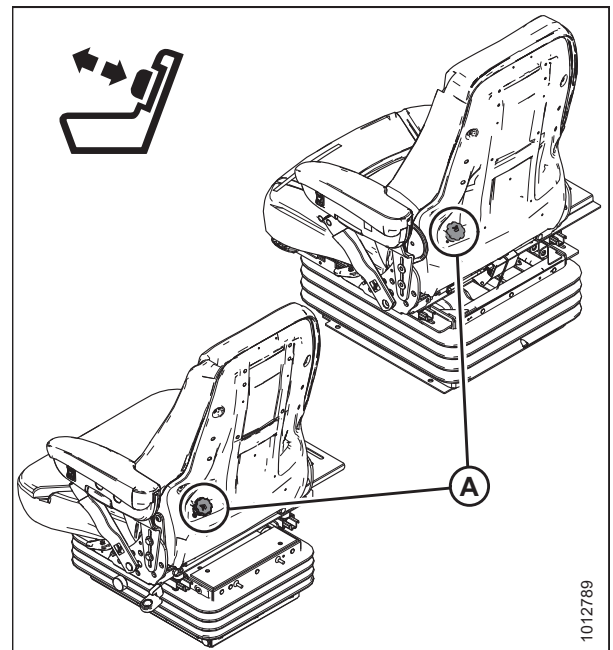

Figure 3.10: Operator's Seat Lumbar Support Controls

3.3.8 Vertical Dampener

Use controls to adjust the seat's vertical suspension dampening.

- Turn knob (A) counterclockwise to increase vertical dampener.
- Turn knob (A) clockwise to decrease vertical dampener.

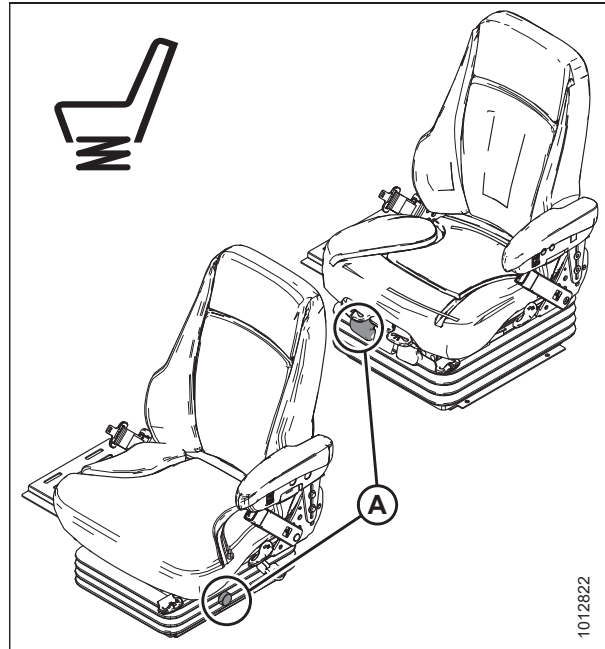

Figure 3.11: Operator's Seat Vertical Dampener Controls

3.3.9 Cushion Tilt – Deluxe Cab Only

Use controls to adjust the deluxe seat's cushion tilt.

1. Pull lever (A) up to release.
2. Tilt the seat cushion up or down.
3. Release lever (A).

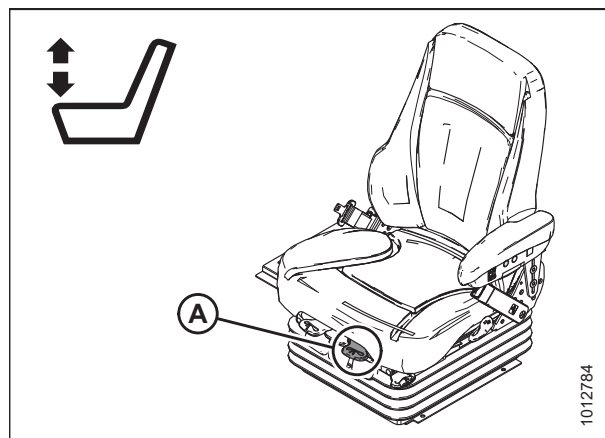

Figure 3.12: Deluxe Seat Cushion Tilt Controls

3.3.10 Cushion Extension – Deluxe Cab Only

Use controls to adjust seat cushion extension fore-aft.

1. Pull lever (A) up to release.
2. Move cushion forward or rearward.
3. Release lever (A).

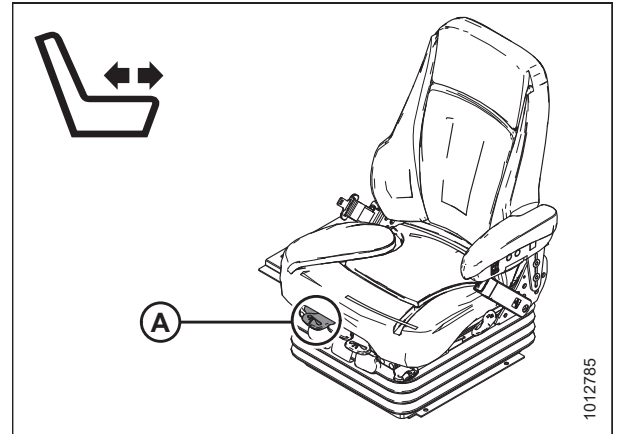

Figure 3.13: Deluxe Seat Cushion Extension Controls

3.3.11 Lateral Isolation Lockout – Deluxe Cab Only

Use controls (A) to lock or unlock the deluxe seat's lateral isolation lockout.

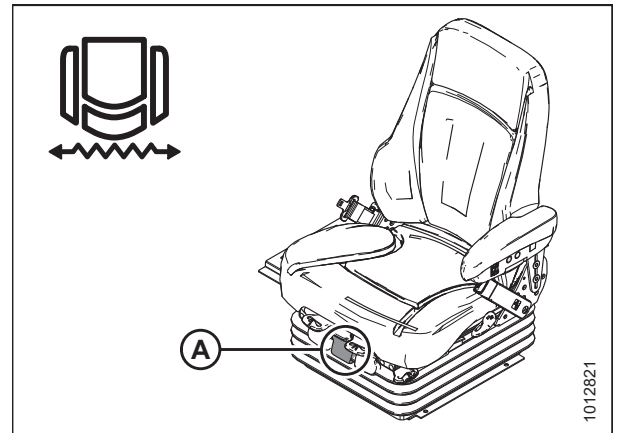

Figure 3.14: Deluxe Seat Lateral Isolation Controls

3.3.12 Heating/Cooling – Deluxe Cab Only

Use the controls to adjust the heating/cooling of deluxe operator's seat.

WARNING

- Do NOT use the seat heating or cooling system if you have a diminished ability to sense temperature, a reduced ability to feel pain, or have sensitive skin. There is a possibility that some people may suffer heat-induced burns or excessive cooling when using the system.
- Do NOT place anything on the seat that insulates against heat or cooling, such as a blanket or cushion. These items may cause the seat heating or cooling system to overheat and cause a heat-induced burn to the seat occupant, or damage to the seat itself.

Seat heating/cooling switch (A)

- Press switch forward for COOL
- Press switch back for HEAT

Heating/cooling high/low/off switch (B)

- Press switch up for HIGH
- Press switch down for LOW
- Center switch for OFF

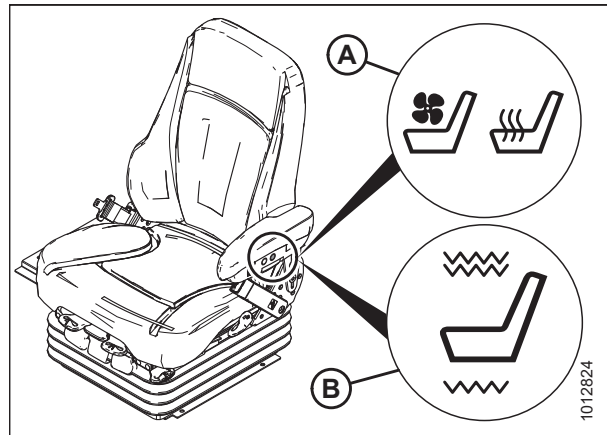

Figure 3.15: Deluxe Seat Heating and Cooling Controls

3.4 Training Seat

A folding wall-mounted training seat (with seat belt) is provided.

WARNING

- The training seat is provided for use by an experienced machine Operator while training a new Operator.
- The training seat is NOT intended as a passenger seat or for use by children. Use the seat belt whenever operating the machine or riding as a Trainer.
- Keep all other riders off the machine.

To store the training seat, lift seat and secure with latch (A).

To lower the training seat, pull latch (A) and lower seat.

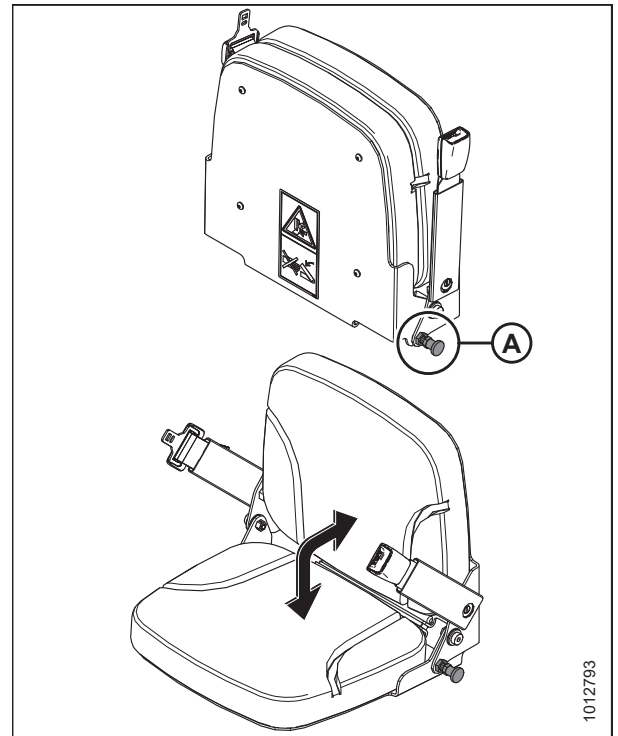

Figure 3.16: Training Seat

3.5 Seat Belts

The windrower is equipped with seat belts on the operator seat and training seat.

⚠ WARNING

Seat belts can help ensure your safety when properly used and maintained.

- Before starting the engine, fasten your seat belt, and ensure that the training seat occupant's seat belt is securely fastened.
- Never wear a seat belt loosely or with slack in the belt system. Never wear the belt in a twisted condition or pinched between the seat structural members.

To fasten seat belt:

1. Pull belt with metal eye (A), at right side of seat, completely across your body.
2. Push the metal eye (A) into buckle (B) until it locks.
3. Adjust the position of the belt as low on your body as possible.

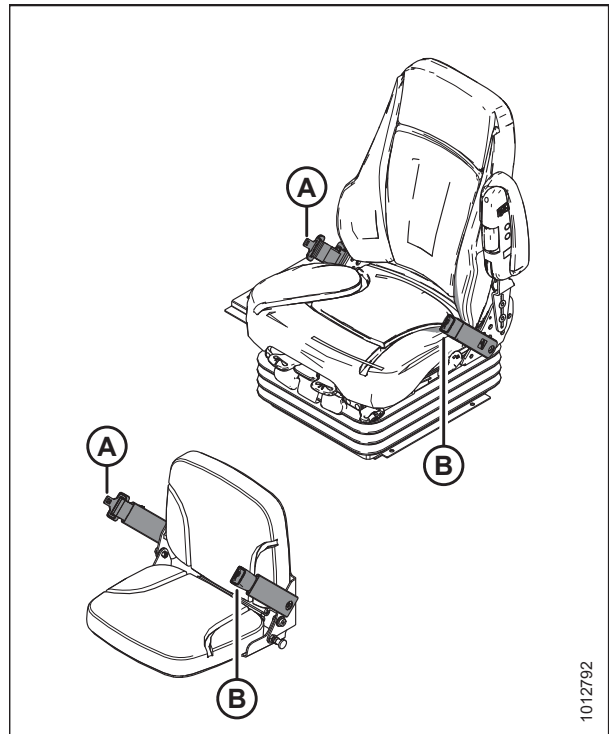

Figure 3.17: Seat Belt

1012792

OPERATOR'S STATION

To release seat belt:

1. Push the red button on the end of buckle (B).
2. Separate buckle (B) from metal eye (A).

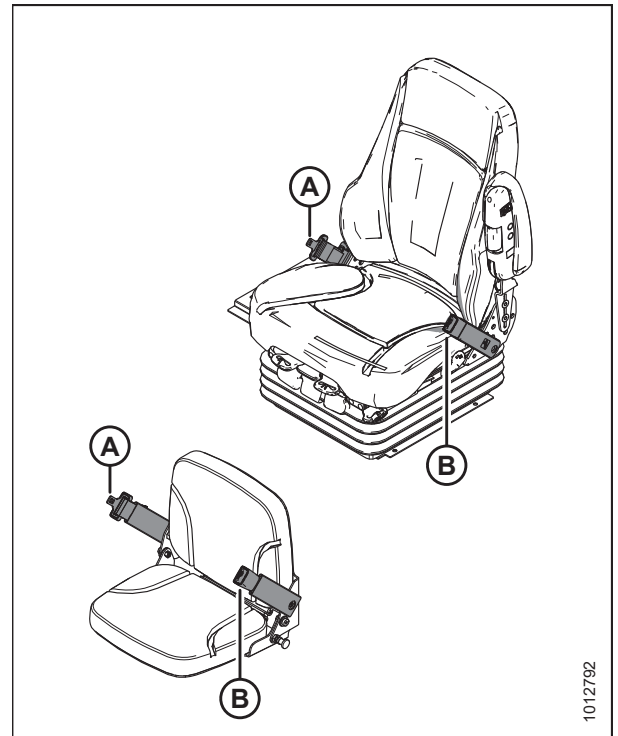

Figure 3.18: Seat Belt

3.6 Adjusting the Steering Column and Steering Wheel

The steering column and steering wheel are adjustable for the operator's comfort and to make it easier to get in and out of the operator's seat.

To adjust the steering column:

1. Hold onto the steering wheel, lift handle (A), and move the steering column forward or backward into the desired position.
2. Release handle (A) to lock the steering column in position.

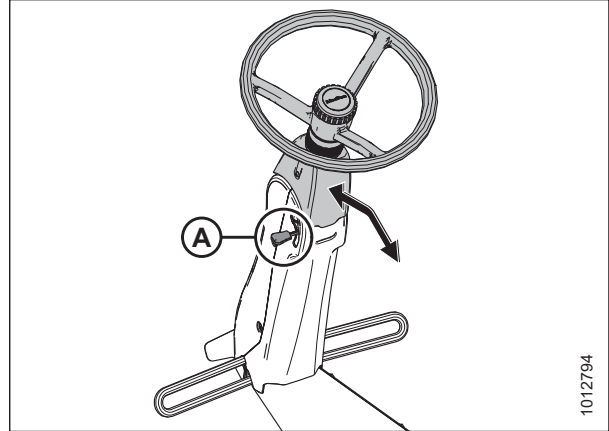

Figure 3.19: Steering Column

To adjust the steering wheel:

1. Hold onto the steering wheel, turn center cap (A) counterclockwise, and move the steering wheel up or down to desired position.
2. Turn center cap clockwise (A) to lock the steering wheel in position.

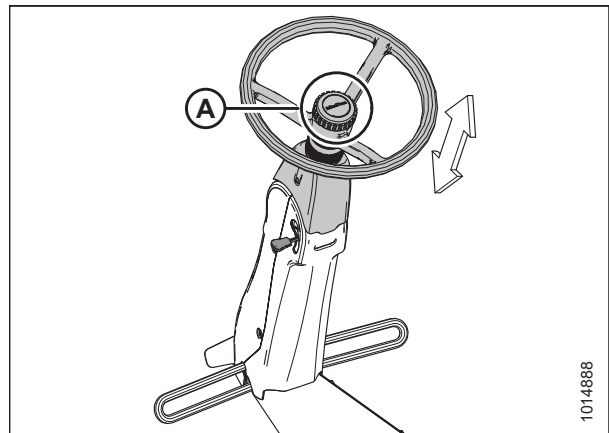

Figure 3.20: Steering Wheel

3.7 Lighting

The field and road light switches are located on the operator's console.

The position of the operator's station (cab-forward or engine-forward) automatically determines which lights are active when the lighting mode is selected.

Field lights (B) do **NOT** turn on when the windrower is in engine-forward mode.

An LED on the switch changes from OFF to amber when the switch is on. The high beam switch has a blue LED that changes from OFF to blue when the switch is on.

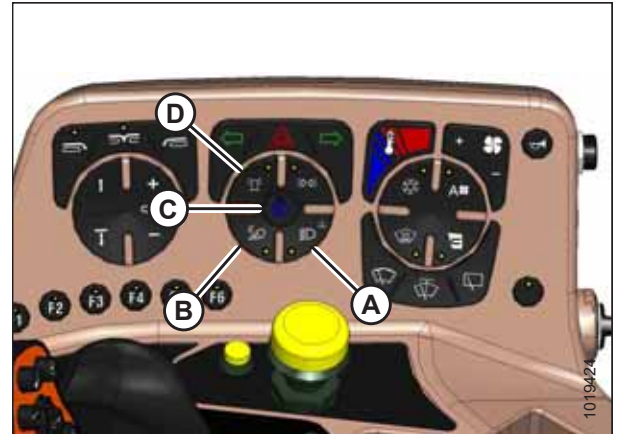

Figure 3.21: Light Switches

- | | |
|-----------------------|------------------|
| A - Road Lights | B - Field Lights |
| C - Low or High Beams | D - Beacons |

3.7.1 Cab-Forward Lighting – Field

The following lights are on when FIELD LIGHT button (A) is selected and the operator's station is locked in cab-forward mode:

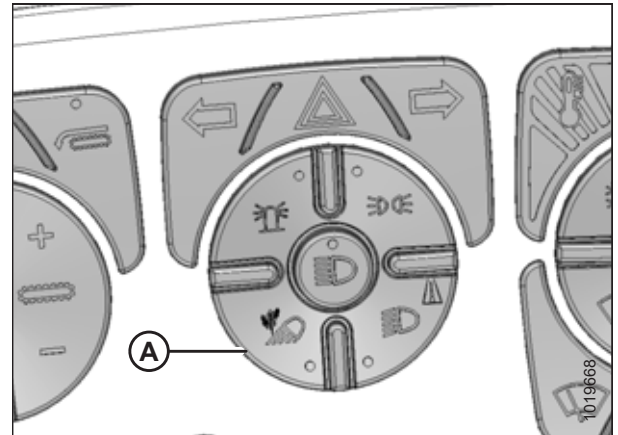

Figure 3.22: Field Light Button

OPERATOR'S STATION

- Cab-forward road lights (A) with low/high beams
- Engine-forward road lights (B) with low/high beams
- Inner work lights (C)
- Outer work lights (D)

NOTE:

Work lights (D) are also turned on when the high beams are activated in cab-forward mode.

- Rear roof work lights (E)
- Rear swath lights (F)

NOTE:

For adjustment procedures, refer to [Aligning Headlights – Cab-Forward, page 407](#).

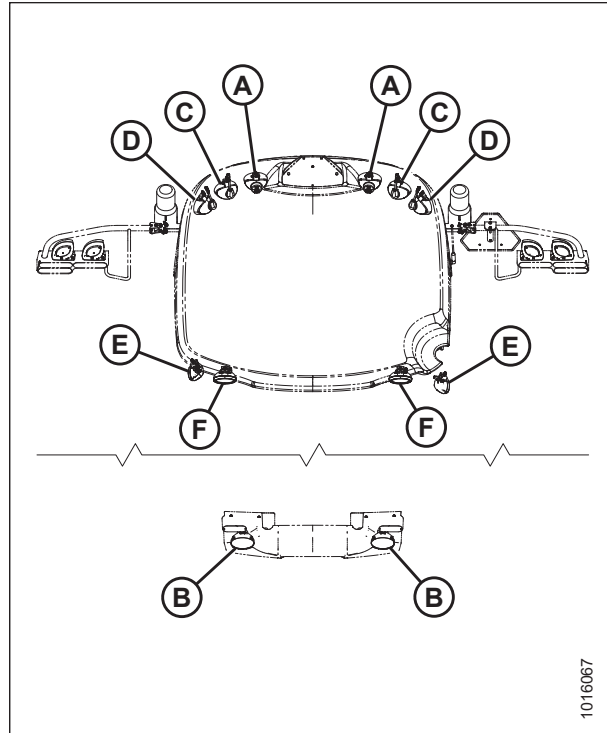

Figure 3.23: Windrower Lighting – Top View

3.7.2 Cab-Forward Lighting – Road

The following lights are functional when ROAD LIGHT button (A) is selected and the operator's station is locked in the cab-forward mode:

- To toggle between low and high beams, press HIGH BEAM button (B)
- To operate hazard lights, press HAZARD LIGHT button (C)

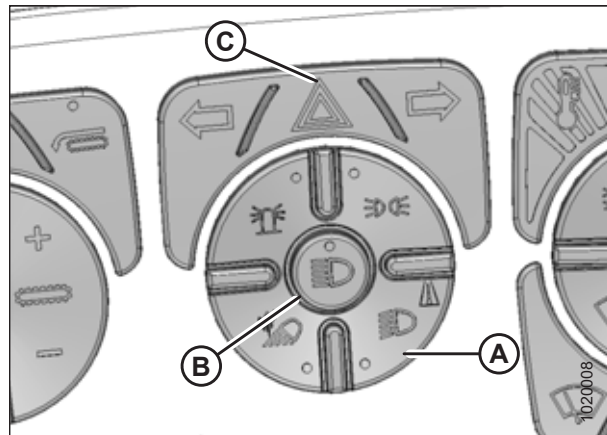

Figure 3.24: Road Light Button

OPERATOR'S STATION

- Headlights (A) with low/high beams
- Red tail lights (B)
- Amber turn signals/hazard lights (C) on mirror supports
- Work lights (D) turn on only when high beams are on in cab-forward mode

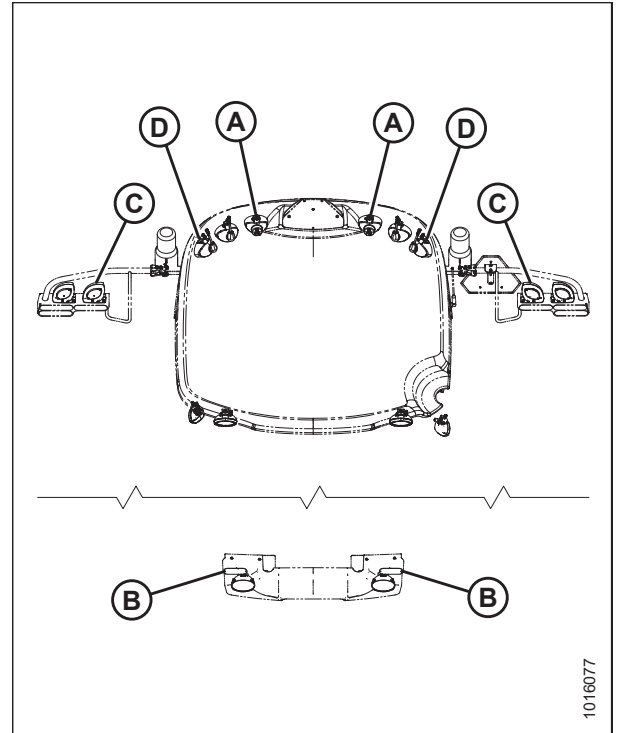

Figure 3.25: Windrower Lighting – Top View

3.7.3 Engine-Forward Lighting – Road

The following lights are functional when ROAD LIGHT button (A) is pressed and the operator's station is locked in the engine-forward mode.

- To toggle between low and high beams, press HIGH BEAM button (B)
- To operate hazard lights press HAZARD LIGHT button (C)

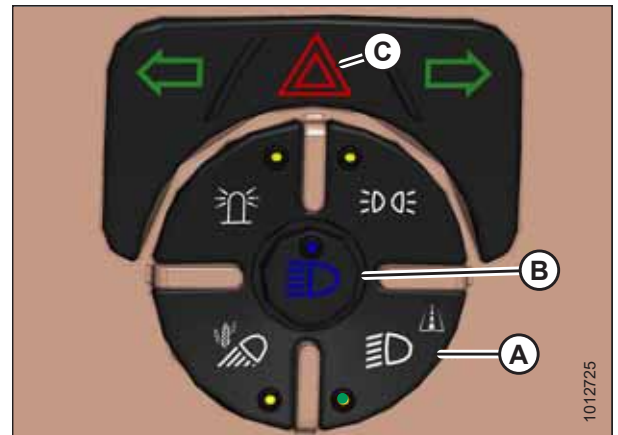

Figure 3.26: Road Light Button

OPERATOR'S STATION

- Engine-forward headlights (A) with low/high beams
- Red taillights (B) on the mirror supports
- Amber turn signals and hazard lights (C) on mirror supports (viewed from the front)
- Work lights (D) turn on only when high beams are activated in engine-forward mode

NOTE:

To align headlights (A), refer to [Aligning Headlights – Engine-Forward](#), page 406.

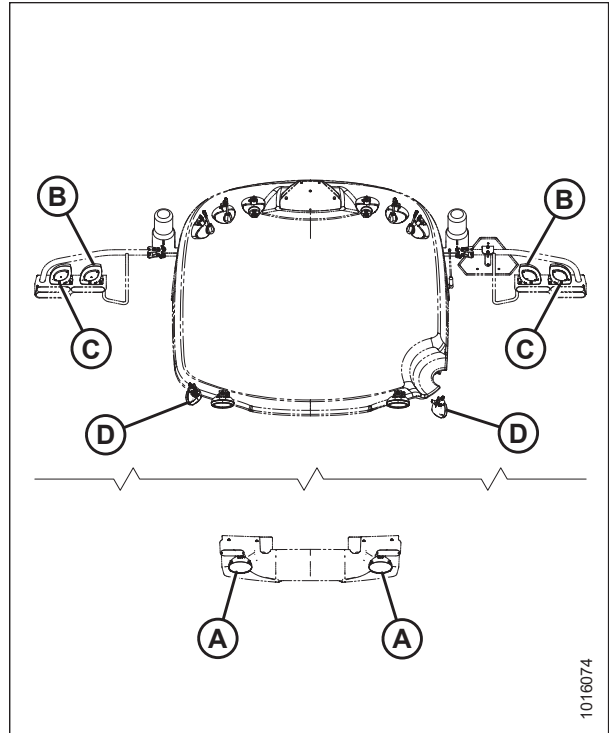

Figure 3.27: Windrower Lighting – Top View

3.7.4 Tail/Beacon Lighting

Beacons (A) are functional when the IGNITION is ON and BEACON button (B) is selected.

NOTE:

In some areas, the law requires the use of beacon lights when driving on the road.

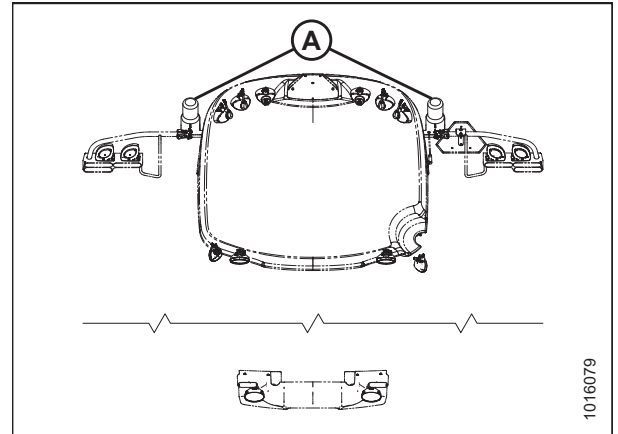

Figure 3.28: Windrower Lighting – Top View

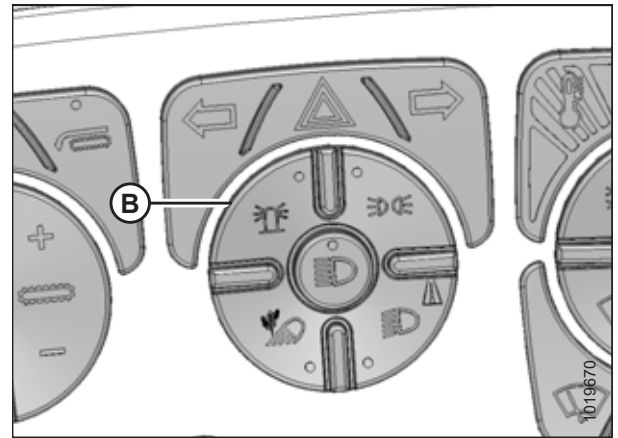

Figure 3.29: Beacon Light Button

3.7.5 Turn Signal / Hazard Lighting

The following lights are on when the LEFT and RIGHT turn signal switches (A) are pressed. Press the switches again to turn the lights off.

- Amber turn signal lights (C) are visible from both front and rear.

NOTE:

Turn signals can also be controlled with the REEL/DISC SPEED switches on the ground speed lever (GSL) when the header is disengaged.

The following lights are on when HAZARD switch (B) is pressed. Press the switch again to turn the lights off.

- Amber hazard lights (C) which are visible from both front and rear.

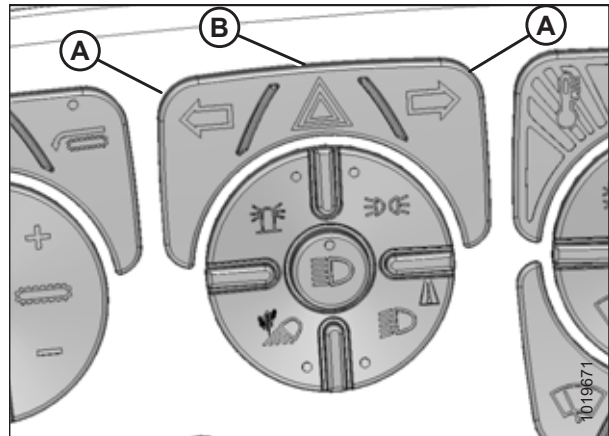

Figure 3.30: Turn Signal/Hazard Button

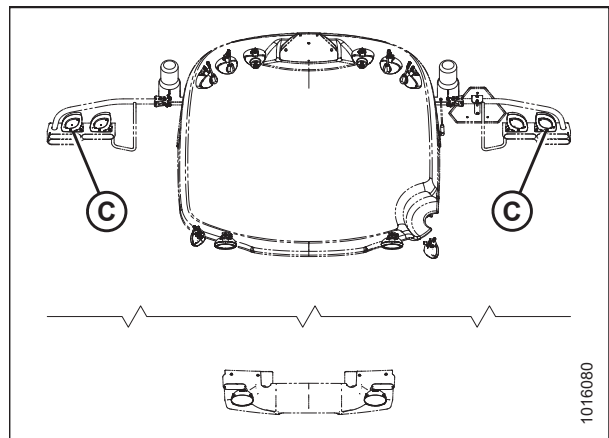

Figure 3.31: Windrower Lighting – Top View

3.8 Windshield Wipers

The windshield wiper controls are located on the console. The illustration shows the controls in cab-forward mode.

Button (A) activates the front (cab-forward) wiper, and button (B) activates the rear wiper.

One window washer button (C) applies washer fluid to both the front and rear wipers as follows:

- If both wipers are on, pressing and holding window washer button (C) will spray washer fluid onto both windows. When the button is released, the washer fluid stops, but both wipers continue to operate.
- If both wipers are NOT on, pressing and holding window washer button (C) will spray washer fluid onto both windows, and both wipers will turn on. When the button is released, the washer fluid stops, but both wipers continue to operate for 4 seconds before automatically stopping.
- If only one wiper is on, pressing and holding window washer button (C) will activate the other wiper and spray washer fluid onto both windows. When the button is released, the washer fluid stops, and the active wiper will continue to operate while the activated wiper operates for only 4 seconds before automatically stopping.

You can aim rear wiper washer nozzle (A) by turning it with a flat head screwdriver.

NOTE:

The front wiper washer nozzle is nonadjustable.

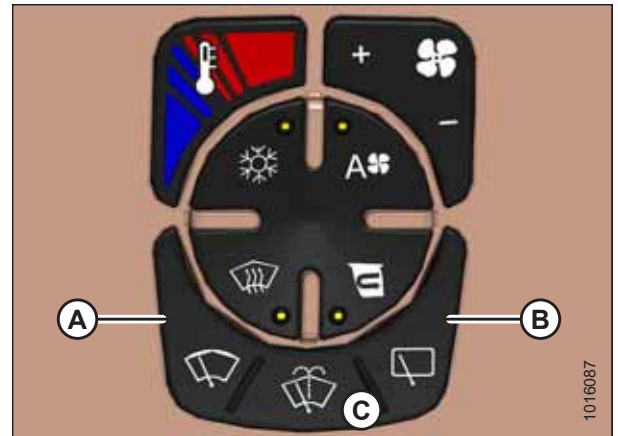

Figure 3.32: Wiper Controls

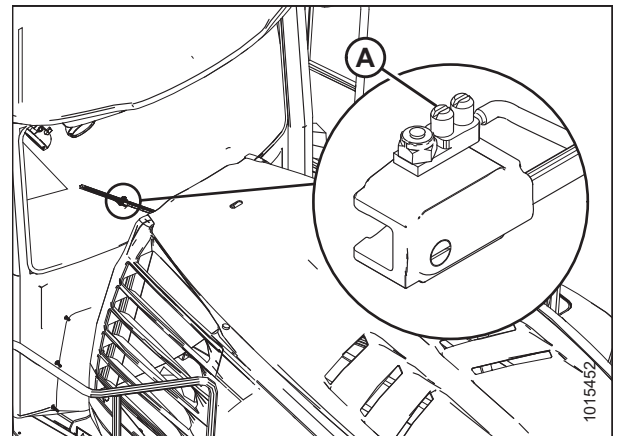

Figure 3.33: Rear Wiper Washer Nozzle

3.9 Rear View Mirrors

Two outside-mounted adjustable mirrors (A) provide a rear view when the windrower is in cab-forward mode.

A single interior-mounted mirror (B) provides a rear view in the engine-forward mode.

Mirror/light assemblies (A) are designed to fold back if accidentally struck.

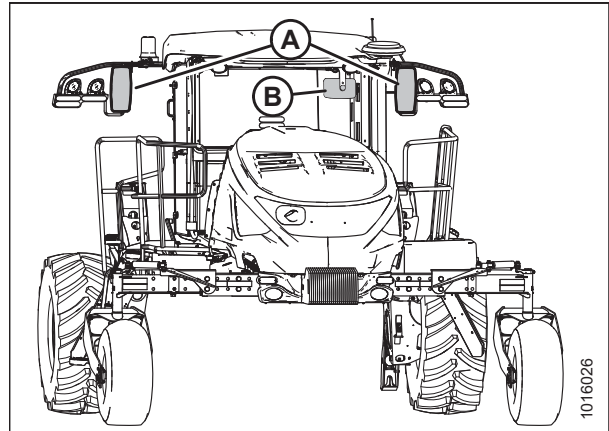

Figure 3.34: Mirrors

The deluxe cab is equipped with power adjustable exterior mirrors which can be adjusted using knob (A) located next to the radio inside the cab.

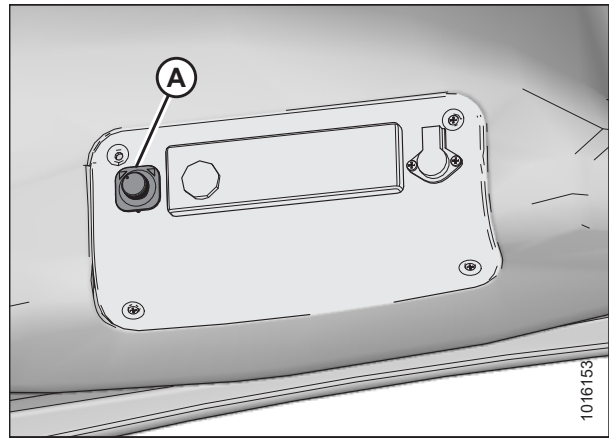

Figure 3.35: Mirror Adjustment Knob

3.10 Cab Temperature

The cab environment is controlled by a climate control system that provides clean air-conditioned or heated air.

The heater/evaporator/blower assembly is located under the cab floor and is accessible from beneath the windrower.

3.10.1 Heater Shut-Off Valve

A shut-off valve (A) at the engine allows the cab heater to be isolated from the engine coolant.

The valve must be open to provide heat to the cab, but can be closed for maximum cooling.

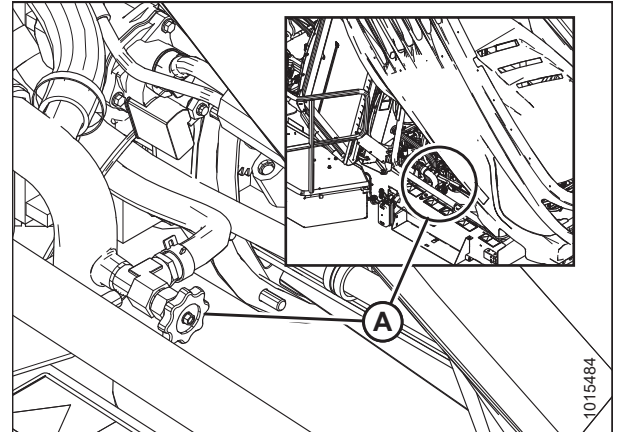

Figure 3.36: Heater Shut-Off Valve

3.10.2 Air Distribution

Cab air distribution is controlled through adjustable air vents (A) located in the cab posts.

You can adjust the vent to open/close (B) or to change direction (C) of the air flow.

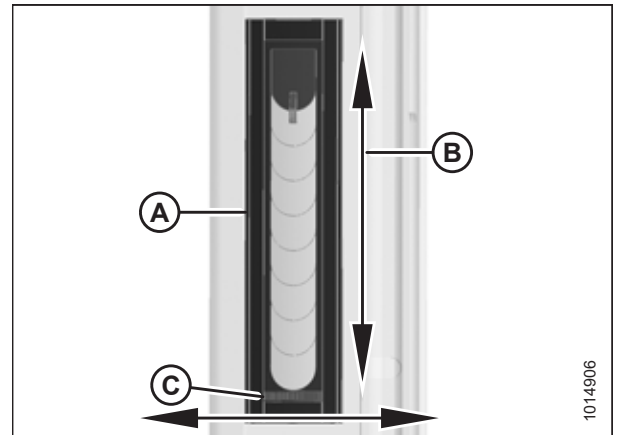

Figure 3.37: Adjustable Air Vents

3.10.3 Climate Controls

NOTE:

When switches (A), (C), (D), and (E) are activated, the LED light on the switch will turn amber.

Auto fan speed switch (A)

Sets the climate control system to auto mode, which automatically adjusts the fan speed to maintain the set-point temperature.

Blower control toggle switch (B)

Controls the blower speed. Overrides auto fan control.

- Press + for more air flow
- Press – for less air flow

Recirculating air switch (C)

Controls the air source; stops booster fan so cab air is recirculated.

Windshield defog/defrost switch (D)

The windshield defog/defrost operates with A/C switch (E) ON.

Air conditioning (A/C) switch (E)

Controls the A/C system.

The A/C operates with the blower switch ON and blower speed is set above 0.

Temperature control toggle switch (F)

Controls cab temperature.

- Press red (top) area to increase cab temperature.
- Press blue (bottom) area to decrease cab temperature.

IMPORTANT:

When starting the windrower after more than 1 week of storage, it may be necessary to distribute the refrigerant oil throughout the A/C system. For instructions, refer to [Air Conditioning Compressor Coolant Cycling, page 114](#).

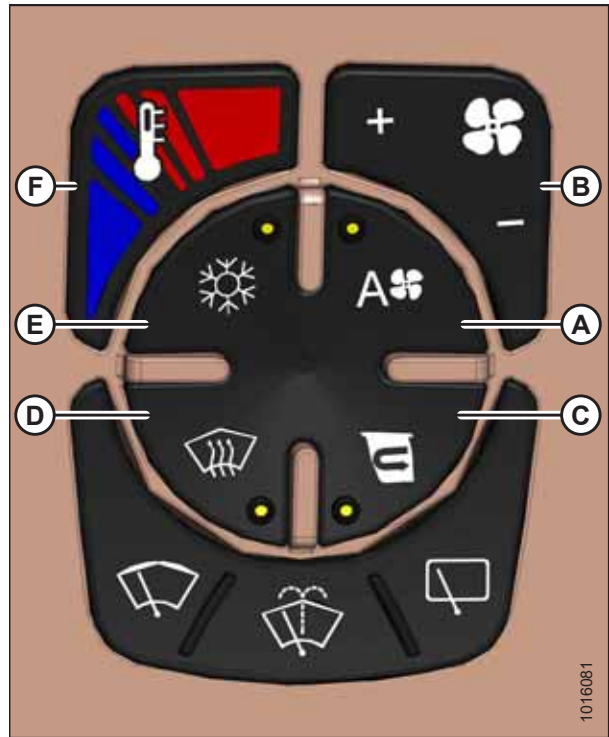

Figure 3.38: Climate Controls

3.11 Operator Amenities

The operator's station in the windrower cab includes the following amenities:

Operator's console

The operator's console has the following features:

- Auxiliary power outlets (A)
- USB jack (B)
- Utility tray under armrest (C)
- Utility tray (D)
- Cup holder (E)

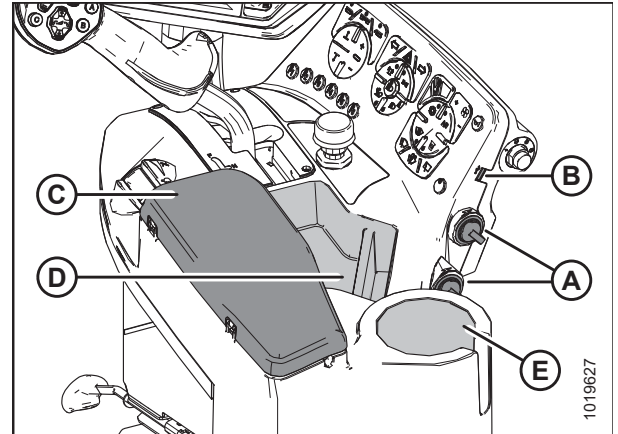

Figure 3.39: Console

Window shades

Retractable window shades (A) are located at the front and rear windows.

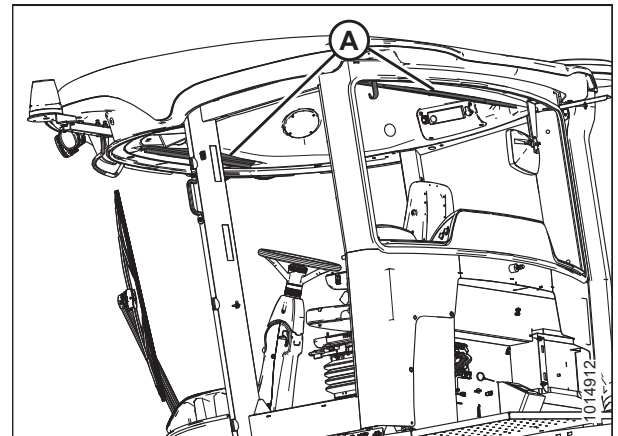

Figure 3.40: Window Shades

Manual storage

A plastic case (A) is located behind the training seat to store the windrower manuals.

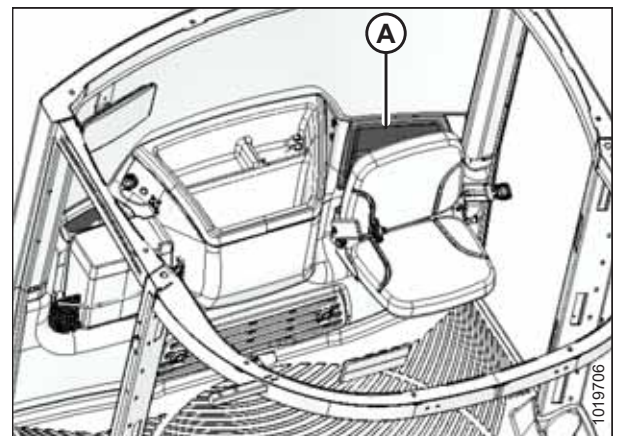

Figure 3.41: Manual Storage Location

OPERATOR'S STATION

Coat hook

A coat hook (A) is located above the training seat, to the left of the Operator.

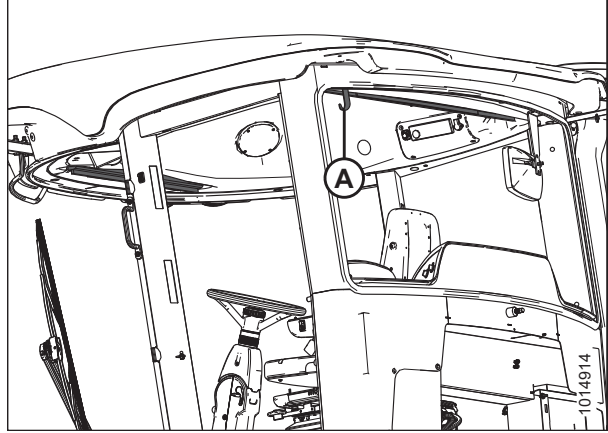

Figure 3.42: Coat Hook

3.12 Radio

The M1240 Windrower comes equipped with an AM/FM/CD/USB/Bluetooth® radio. The following procedures describe how to activate and pair Bluetooth® devices with the radio.

3.12.1 AM/FM/CD/USB Radio with Bluetooth® Wireless Technology

A radio (A) and two speakers (B) are factory-installed in the cab headliner. The radio operates in AM, FM, CD, and USB modes. It also supports Bluetooth® wireless technology audio streaming and hands-free calling. For instructions, refer to the operating instructions supplied with the radio.

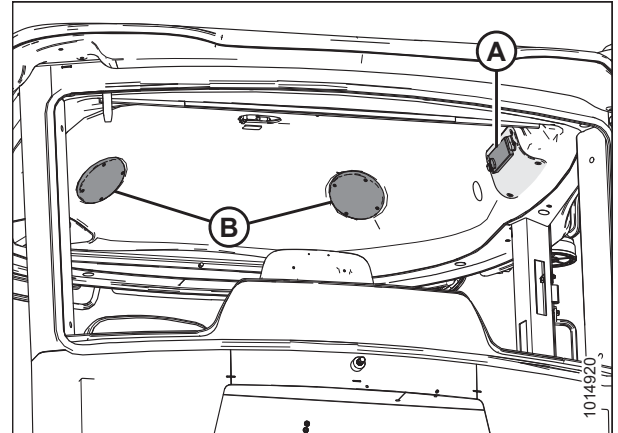

Figure 3.43: Radio and Speakers

To locate the operating instructions for the radio, follow this procedure:

1. Turn latch (A) to unlock relay module cover (B).
2. Retrieve the operating instructions for the radio from relay module cover (B) access panel in the cab roof liner.

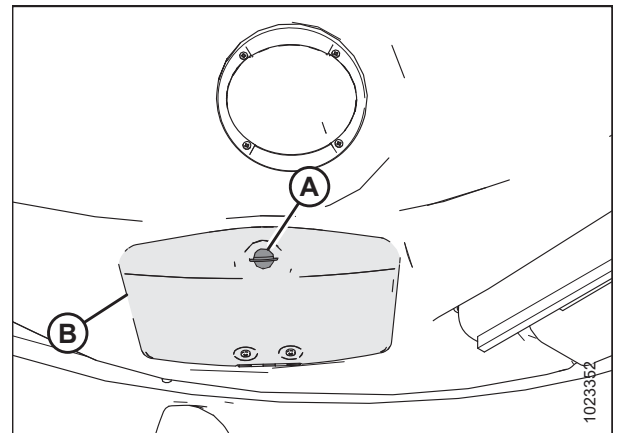

Figure 3.44: Relay Module Cover

OPERATOR'S STATION

- When finished with the radio manual, place the manual in manual storage case (A) located behind the training seat.

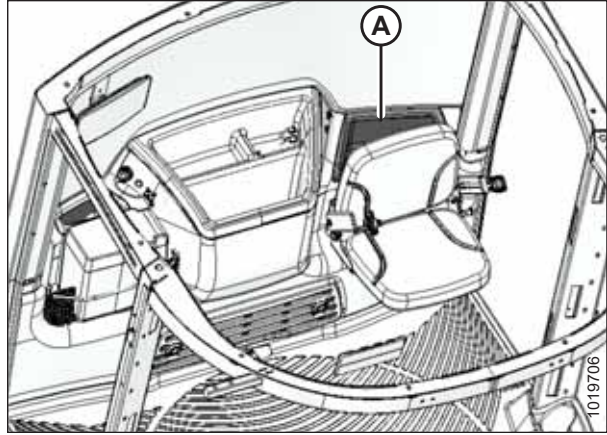

Figure 3.45: Manual Storage Location

- Close relay module cover (B) and turn latch (A) to lock it.

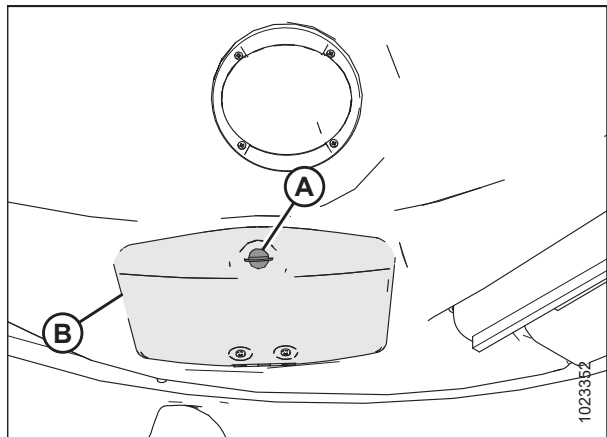

Figure 3.46: Relay Module Cover

Activating Bluetooth® Feature

The Bluetooth® feature must be activated to allow mobile device pairing.

To activate the Bluetooth® feature, follow this procedure:

- Press POWER button (A) to turn the radio on.
- Press and hold VOL/SEL knob (B) for 2 seconds. MENU is displayed on screen (C).
- Rotate VOL/SEL knob (B) to highlight BT SET menu and press the VOL/SEL knob to select. BLUETOOTH ON/OFF is displayed (C).
- Press VOL/SEL knob (B) to select BLUETOOTH.
- Rotate VOL/SEL knob (B) to display ON and press VOL/SEL knob (B) to select.
- Rotate VOL/SEL knob (B) and select DISCOVER.
- Rotate VOL/SEL knob (B) to display ON and press VOL/SEL to select.

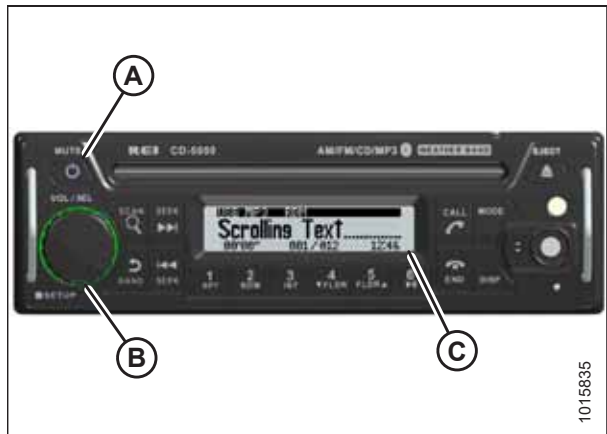

Figure 3.47: Bluetooth® Radio

Pairing a Bluetooth® Device

The installed radio allows the operator to pair a Bluetooth® phone or audio device. Before proceeding, check that Bluetooth® is enabled and radio has been set to DISCOVER mode. For instructions, refer to [Activating Bluetooth® Feature, page 64](#).

To pair a mobile device, follow this procedure:

1. Press POWER button (A) to turn radio ON.
This will set the radio to Bluetooth® discover mode if the Bluetooth® feature has been activated.
2. Turn the mobile device's Bluetooth® to ON. For instructions, refer to the device's operator's manual. The radio appears as a discoverable device.
3. Select CD-5000 BT on the mobile device to connect.

NOTE:

A passkey is required to connect to the Bluetooth® radio. The default passkey is four zeros (0000).

4. Enter the default passkey 0000. The radio will display CONNECTED (B) and the Bluetooth® icon (C) appears in the upper right corner of the screen.

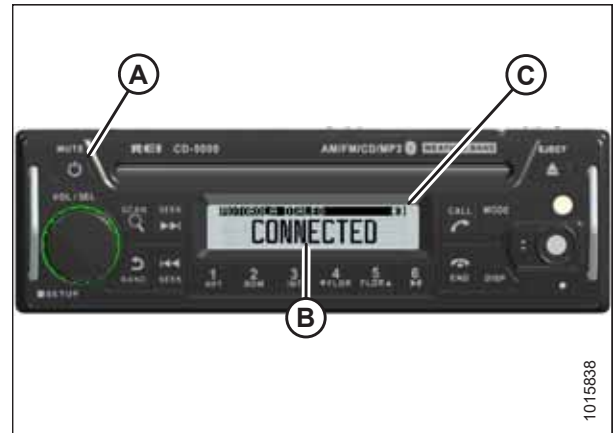

Figure 3.48: Radio Display

3.13 Horn

The horn is activated by pushing button (A) located on the console.

Sound the horn three times prior to starting the engine.

The horn is located under the front left corner of the cab floor when facing cab-forward.



Figure 3.49: Console

3.14 Engine Controls

The following engine controls are conveniently located on the operator's console.

Ignition switch

- ACC (A): The windrower's electrical accessories are turned ON without starting the engine
- OFF (B): All electrical systems OFF
- RUN (C): Engine run position
- START (D): Turn fully clockwise to crank engine, and release to return switch to RUN position.

IMPORTANT:

Remove ignition key when windrower is not in use. The ignition key also locks the doors and tool box in the left platform.

Throttle (A)

Controls engine speed range

- MAX: Push lever forward
- MIN: Pull lever back

Harvest Performance Tracker display (B)

- Fuel level monitoring
- DEF level monitoring
- High exhaust system temperature indicator (HEST)
- Exhaust system cleaning inhibit and forced indicator
- Speed monitoring (ground, engine, knife/disc, reel, conveyor, and cooling fan)
- Pressure monitoring (knife, reel, conveyor, and supercharge)
- Engine parameters (coolant temperature, fuel consumption, and engine load)
- Header position

For more information on the Harvest Performance Tracker, refer to [3.17 Harvest Performance Tracker Display, page 77](#).

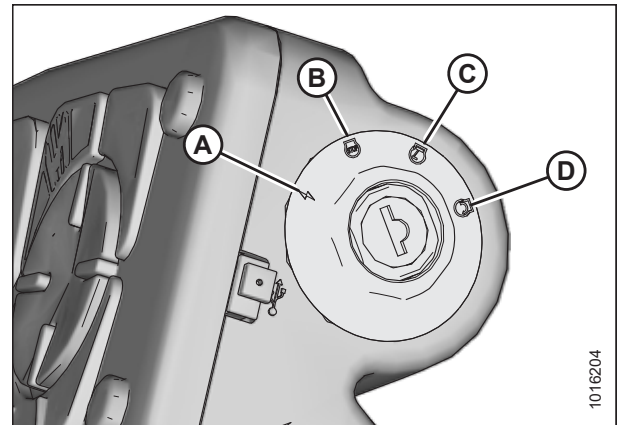

Figure 3.50: Ignition Switch on Operator's Console

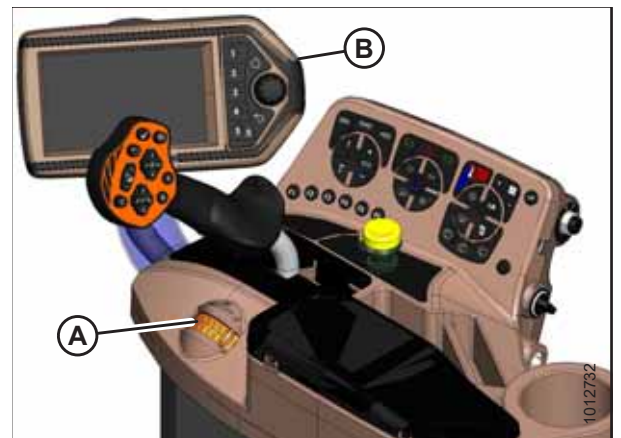

Figure 3.51: Engine Controls

3.14.1 Using Eco Engine Control

Eco Engine Control (EEC) is useful in lighter crop conditions that do not require the maximum engine rpm. The reduced engine speed lowers fuel consumption, noise levels, and exhaust emissions in addition to reducing engine wear.

The EEC limits the engine to 1900–2200 rpm when the header is engaged, and is adjustable in 100 rpm increments. Activate this feature by using EEC button (A) on the operator's console. The EEC symbol will display on the Harvest Performance Tracker (HPT) screen over the right side of the tachometer.

The EEC feature will only be active when the header is engaged, but can be adjusted without the header running. When the header is disengaged, EEC will be canceled and engine rpm will return to the setting determined by the throttle.

Use the QuickMenu to adjust EEC rpm. For instructions, refer to [QuickMenu System, page 82](#).

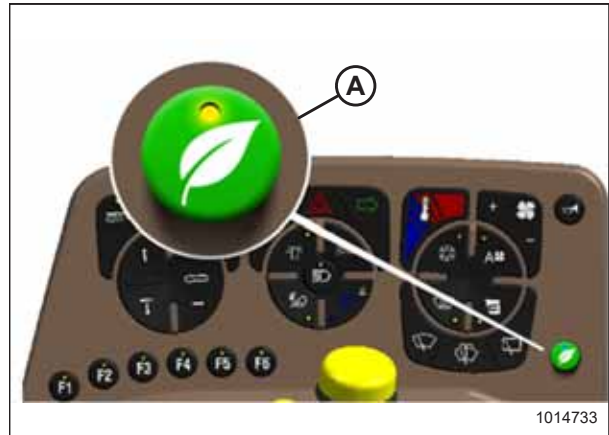

Figure 3.52: Eco Engine Control (EEC)

3.15 Windrower Controls

Console controls:

Turn signals (A) – Activates turn signals on windrower and header.

- Push-ON/Push-OFF (activating the hazard switch also cancels the turn signal)

Ground speed lever (GSL) (B) – Controls speed and direction of movement.

- F: Forward
- N: NEUTRAL
- PARK: Engages neutral interlock, and applies park brake when steering locked in center
- R: Reverse

Hazard warning lights (C) – Activates signals on windrower and header.

- Push-ON / Push-OFF

PARK (D) – Engages neutral interlock, and applies park brake when steering locked in center.

Horn (E)

Autosteer engagement button (F) – Engages/disengages the automated steering system (if installed).

- ENGAGE: Click to engage
- DISENGAGE: Turn steering wheel to disengage

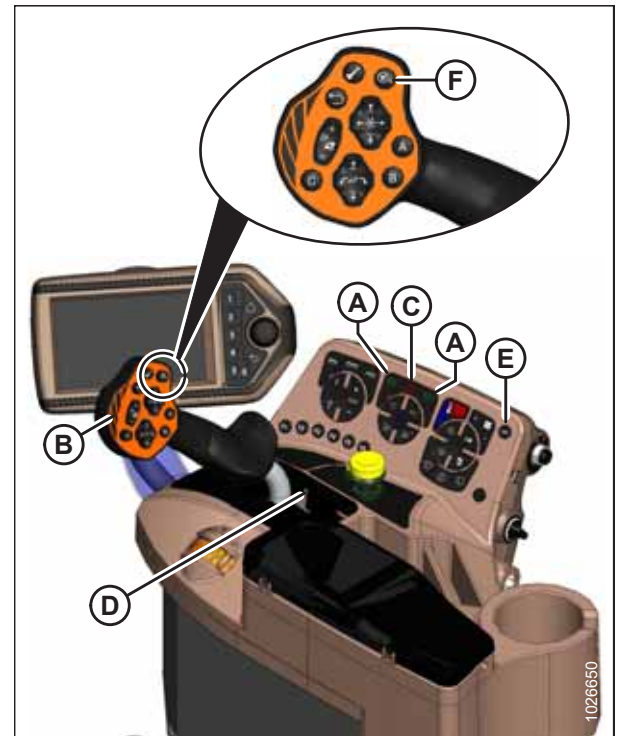

Figure 3.53: Console Controls and Autosteer

3.16 Header Controls

All header controls are conveniently located on the operator's console and on the ground speed lever (GSL) handle.

NOTE:

Some controls are optional equipment and may not be present in your unit. Some controls may be installed, but are not functional for certain headers.

Refer to specific header sections in this manual for detailed operating procedures for all header controls.

3.16.1 Header Engage Switch

Header engage switch (A) engages and disengages the header drive.

To engage header: Push and hold HEADER ENGAGE switch (A) down while pulling up on collar (B).

To disengage header: Push HEADER ENGAGE switch (A) down.

NOTE:

Although not required, it is good practice to move the throttle lever back to IDLE before engaging the header drive.

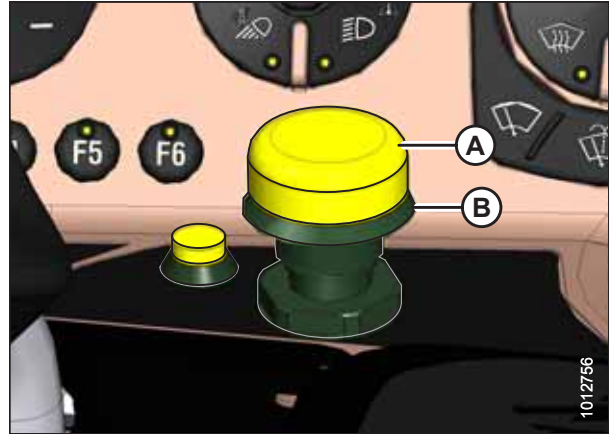

Figure 3.54: Header Engage Switch

3.16.2 Header Drive Reverse Button

NOTE:

R1 Series and R2 Series Rotary Disc Headers do **NOT** have any reverse capability.

NOTE:

The following header systems have reverse capability:

- D1XL Series Draper Headers: knife
- D1X Series Draper Headers: knife
- A40DX Auger Headers: knife, conditioner, auger and reel
- A40DX GSS Auger Headers: knife, auger and reel

Reverse header systems as follows:

- **Engage:** Push and hold reverser button (B) and engage header with switch (A).
- **Disengage:** Release reverser button (B).

NOTE:

To re-engage in forward operation, push switch (A) down and then up again.



Figure 3.55: Header Drive Controls

3.16.3 Ground Speed Lever Switches

The switches on the Ground Speed Lever (GSL) (A) control the most common header functions.



Figure 3.56: Ground Speed Lever (GSL)

GSL controls — front

- One-Touch-Return position switch (A)
- One-Touch-Return position switch (B)
- One-Touch-Return position switch (C)
- Reel or disc speed (D) (also operates turn signals when header disengaged)
- Reel position (E)
- Autosteer engagement (F) (if equipped)
- Header position (G)
- Back switch (H) – controls Harvest Performance Tracker (HPT) functions
- Select switch (J) – controls HPT functions



Figure 3.57: GSL Function Groups

OPERATOR'S STATION

GSL controls — rear

- Shift switch (A)
- Scroll wheel (B)

NOTE:

When the shift switch is used with another button it performs the following shortcut functions:

- SHIFT + BACK – Home page
- SHIFT + SELECT – Main menu access
- SHIFT + SCROLL – Adjust maximum ground speed

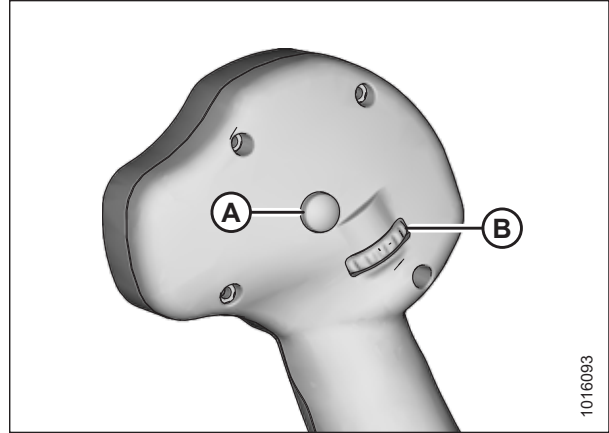

Figure 3.58: GSL Function Groups

Header Position Six-Way Switch

The six-way switch on the Ground Speed Lever (GSL) raises, lowers, and tilts the header.

- To lower header slowly, press (A) lightly
- To lower header quickly, press (A) fully
- To raise header slowly, press (C) lightly
- To raise header quickly, press (C) fully
- To tilt header downward, press (B)
- To tilt header upward, press (D)

Release switch at desired position.

NOTE:

Header raise and lower rates are adjustable on the HPT display. For instructions, refer to [4.7.8 Adjusting Header Raise and Lower Rates, page 232](#) or header setup in [Menu Icons, page 84](#).

NOTE:

For detailed switch operating modes, refer to the section in this manual that is specific to your header.



Figure 3.59: Ground Speed Lever

Reel Position Four-Way Switch

The reel position four-way switch on the Ground Speed Lever (GSL) performs different functions depending on the attached options.

For specific operating instructions, refer to the following sections:

- Reel fore-aft position and height on draper headers:
 - 4.8.2 Adjusting Reel Fore-Aft Position, page 234
 - 4.8.3 Adjusting Reel Height, page 235
- Center-link assist cylinder:
 - 4.4.2 D1X or D1XL Series Draper Header, page 162
 - 4.4.1 A40DX Auger Header, page 151
- Double windrow attachment (DWA) position:
 - 4.7.6 Double Windrowing, page 229

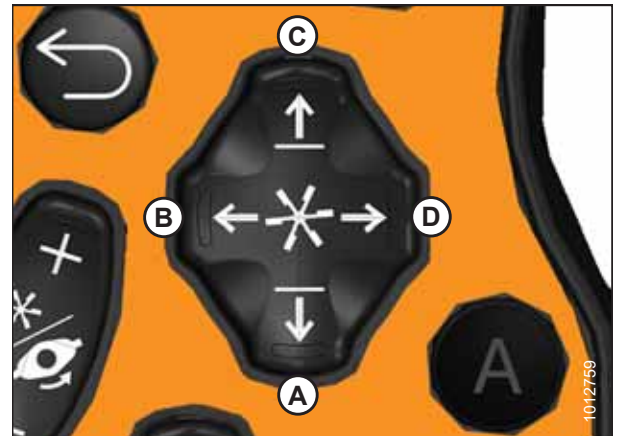

Figure 3.60: Ground Speed Lever

A - Reel Down
 B - Reel Forward
 C - Reel Up
 D - Reel Aft

Reel and Disc Speed Switch

The reel and disc speed switch on the Ground Speed Lever (GSL) adjusts the reel or disc speed, depending on the type of header. The switch can also operate the turn signals on the windrower when the header is not in use.

- Press and hold the + button (A) to increase the reel or disc speed.
- Press and hold the – button (B) to decrease the reel or disc speed.
- Release the button at the desired speed.

For instructions, refer to the applicable header topic for detailed use of these switches.

NOTE:

The REEL and DISC SPEED switch can operate the turn signals when the header is not in use. For example, when driving in the engine-forward position, or when operating in cab-forward position with the header disengaged.

NOTE:

The reel and auger speeds are hydraulically linked on the A40DX Auger Header. When the reel speed is changed, the auger speed changes automatically. Independent reel and auger adjustment is available on the A40DX GSS (Grass Seed) using the differential auger-reel control feature. It is also available on the A40DX (not Grass Seed) as an option: the Reel Speed Control kit (MD #B6604).

IMPORTANT:

Reel speed on an A40DX Auger Header **MUST NOT EXCEED** 85 rpm. Auger speed **MUST NOT EXCEED** 320 rpm.



Figure 3.61: GSL Reel and Disc Speed Switch

OPERATOR'S STATION

One-Touch-Return Buttons (A, B, C)

The One-Touch-Return buttons on the Ground Speed Lever (GSL) save header configuration settings and serve as presets for quickly returning the header to specific settings.

The One-Touch-Return buttons **A**, **B**, and **C** always save header height settings, but the following settings can also be saved depending on the header type:

- Header tilt
- Deck position/header float selection
- Double windrow attachment (DWA) or swath compressor raise/lower
- DWA speed
- Knife speed
- Draper speed
- Reel speed
- Reel height
- Reel fore-aft
- Disc speed



Figure 3.62: One-Touch-Return Buttons on GSL

To program the One-Touch-Return buttons, press and hold button A, B, or C on the GSL handle for 3 seconds until an audible tone is heard, indicating the current header settings are saved to that button.

To return header to a preset condition, tap the A, B, or C button quickly. Holding the One-Touch-Return button too long can inadvertently reprogram the current header settings.

Pressing a programmed A, B, or C button opens a run screen that shows corresponding letter (A) on the screen for the preset.



Figure 3.63: One-Touch-Return Buttons on GSL

3.16.4 Console Header Buttons

Console header buttons (A) adjust the following header functions:

- Deck shift/float preset
- Draper speed
- Double windrow attachment (DWA) or swath compressor lift functions



Figure 3.64: Console Header Buttons

Deck Shift / Float Presets

Draper header with deck shift option:

- Controls the draper deck position for double windrowing with a draper header.
- Set header float for each deck position. For instructions, refer to [Setting the Float, page 222](#).

NOTE:

The last float setting used in any deck shift position will be stored into memory automatically.

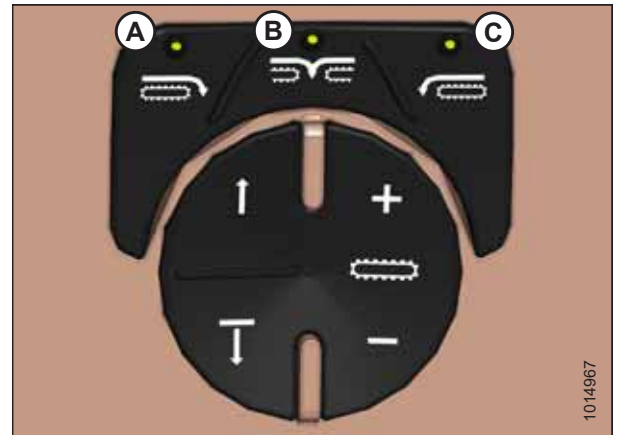

Figure 3.65: Header Deck Shift Buttons
 A - Right-Side Delivery B - Center Delivery
 C - Left-Side Delivery

Float presets:

When used with a rotary disc header, auger header, or draper header, these buttons select header float presets. For instructions, refer to [4.10.3 Setting Float Options with Fixed Deck, page 281](#) to learn how to preset the float.

NOTE:

For detailed switch operating modes, refer to the section in this manual that is specific to your header.

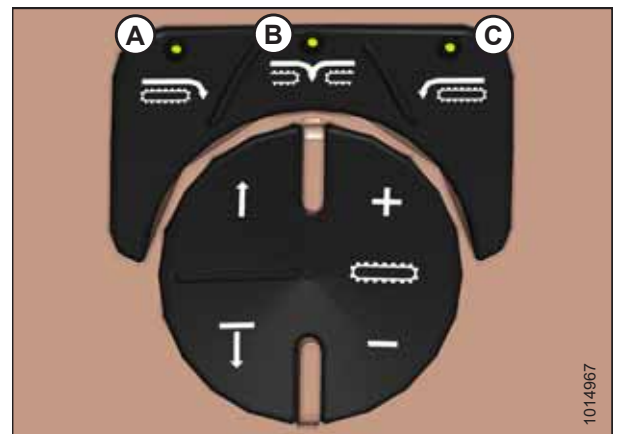

Figure 3.66: Header Switches
 A - Float Preset 1 B - Float Preset 2
 C - Float Preset 3

OPERATOR'S STATION

Conveyor Speed Adjustment Buttons

Adjust header or double windrow attachment (DWA) conveyor speed by pressing switch (A) to increase the speed, or switch (B) to decrease the speed.

Conveyor speed can be adjusted in either manual or auto modes. For instructions, refer to [4.8.6 Adjusting Draper Speed](#), page 243 for more information.

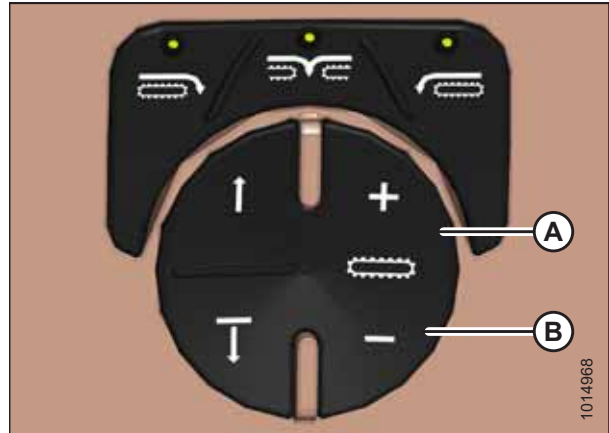

Figure 3.67: Operator's Console Conveyor Controls

Auxiliary Lift Switches

With double windrow attachment (DWA):

- Raise the DWA deck by pressing button (A), or lower the deck by pressing button (B).

With swath compressor attachment:

- Raise the swath compressor by pressing button (A), or lower it by pressing button (B).

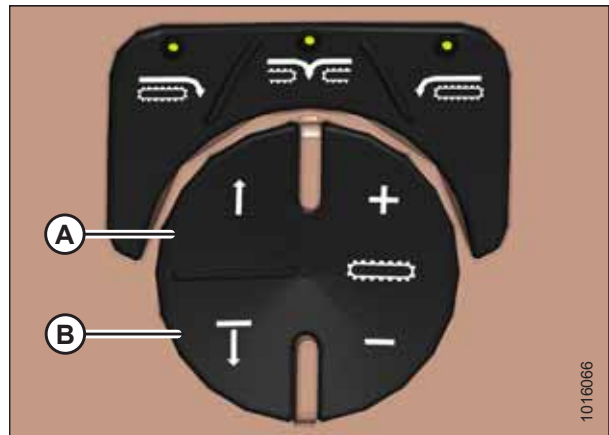

Figure 3.68: Operator's Console Auxiliary Controls

3.17 Harvest Performance Tracker Display

The Harvest Performance Tracker (HPT) display settings are preset at the factory. This section explains how to adjust the settings.

The HPT (A) is located on the operator's console.



Figure 3.69: Operator's Console

3.17.1 Harvest Performance Tracker Screen Layout

The appearance and functions of the Harvest Performance Tracker (HPT) depend on the type of header attached.

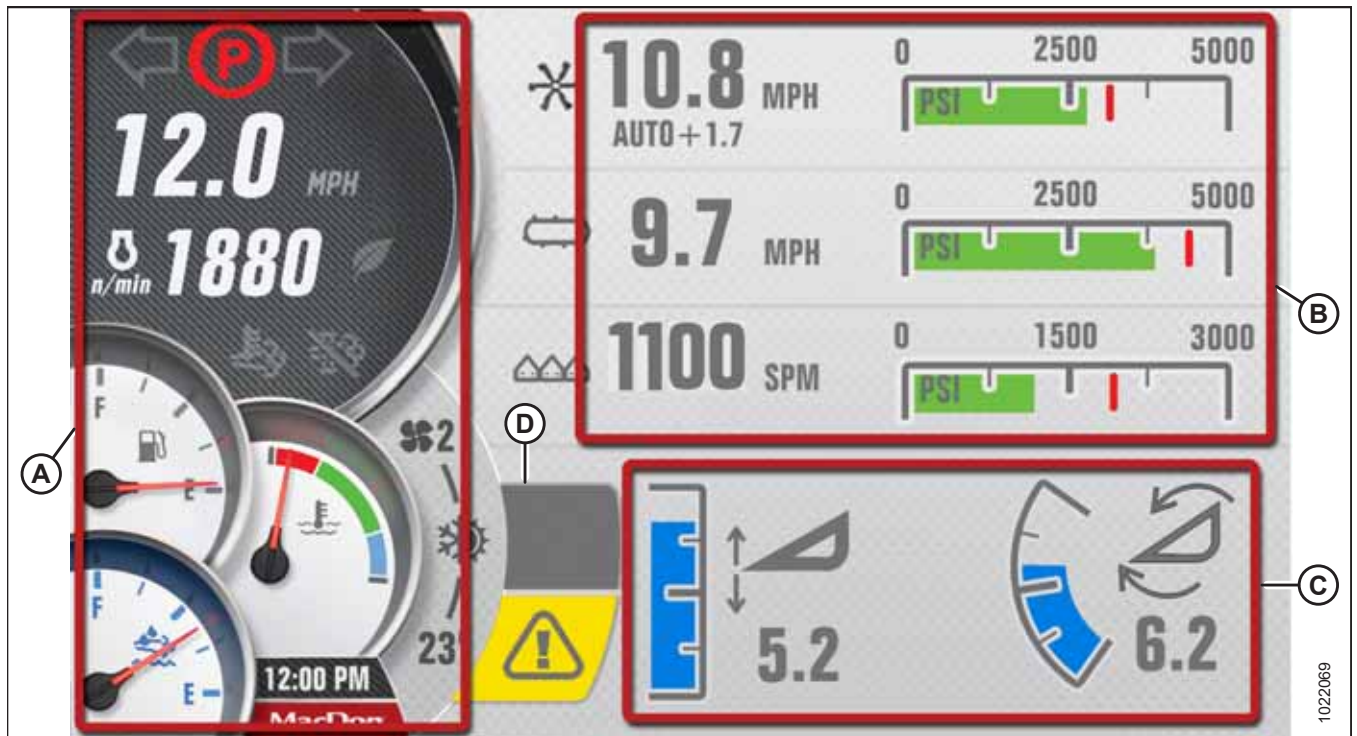

Figure 3.70: Run Screen 1 – Draper Header Shown

A - Left Gauge Cluster

B - Header Information

C - Current Header Position

D - Telltales

OPERATOR'S STATION

The HPT display is separated into the following zones:

Left gauge cluster:

- Ground speed
- Maximum ground speed
- Engine rpm
- Eco engine control (EEC) active/inactive
- High exhaust system temperature (HEST) light
- Inhibit status
- Park and turn signal status
- Level gauges for fuel and diesel exhaust fluid (DEF)
- Coolant temperature gauge
- Climate control temperature and blower speed
- Current time



Figure 3.71: Left Gauge Cluster

Header information:

The information displayed depends on the type of header attached to the windrower and which run screen is active.

- **Run screen #1:** Displays reel, draper, knife, disc, or auger speed and pressure; alarm point; and indexing (factory-set according to header)
- **Run screen #2:** Displays draper, knife, or disc speed and pressure; reel height and fore-aft position; hydraulic pressure; and load bar
- **Run screen #3:** Displays fuel per hour/acre, acres per hour, and sub acres per hour (resettable)
- **Run screen #4:** Displays cooling fan speed, engine air intake temperature, hydraulic oil temperature, and engine coolant temperature



Figure 3.72: Draper Header Information

OPERATOR'S STATION

Current header position:

- Displays basic header functions: height and angle

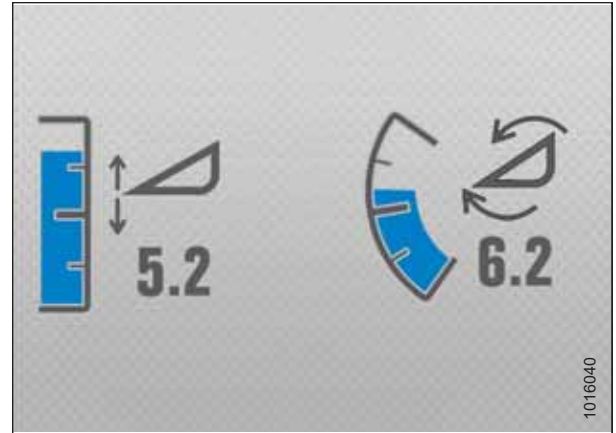

Figure 3.73: Current Header Position

Telltals:

- Telltales (A) indicate an engine or windrower fault
- Telltales are amber or red in color accompanied by a symbol for the fault
- Telltales display a short description (B) of the fault

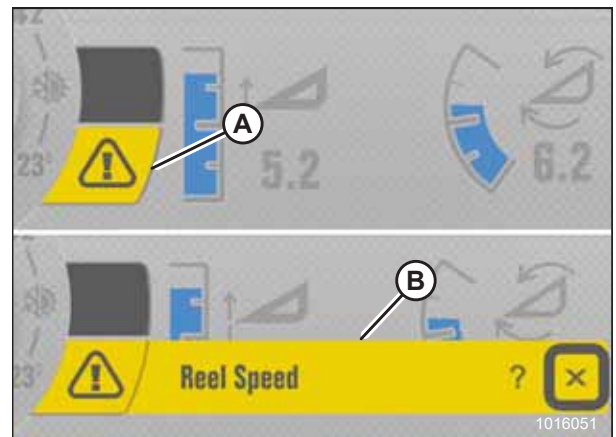

Figure 3.74: Faults/Telltals

Required maintenance indicator:

- An amber indicator (A) is displayed 50 hours before required maintenance is due
- The indicator only displays when header is disengaged
- The indicator flashes when maintenance is overdue by 50 hours



Figure 3.75: Maintenance Indicator

3.17.2 Navigating the Harvest Performance Tracker Display

Scroll Knob, Scroll Wheel, and Select Button

Turning scroll knob (A) on the Harvest Performance Tracker (HPT) display highlights the available options within a menu and adjusts the settings. Pushing the scroll knob selects functions or menu items. Scroll and select functions are duplicated on the ground speed lever (GSL) controls. Unless otherwise specified, both buttons will perform the same function. When SELECT is used in this document, either of these buttons can be used.

- Turn scroll knob (A) clockwise to move selections down the screen, to the right (clockwise), and to increase settings. Push the scroll knob to activate the selection.
- Turn scroll knob (A) counterclockwise to move selections up the screen, to the left (counterclockwise), and to decrease settings. Push the scroll knob to activate the selection.



Figure 3.76: HPT Scroll Knob

NOTE:

Scroll wheel (A) on the back of the GSL and the SELECT button (B) on the front of the GSL perform the same functions as the HPT rotary scroll knob.

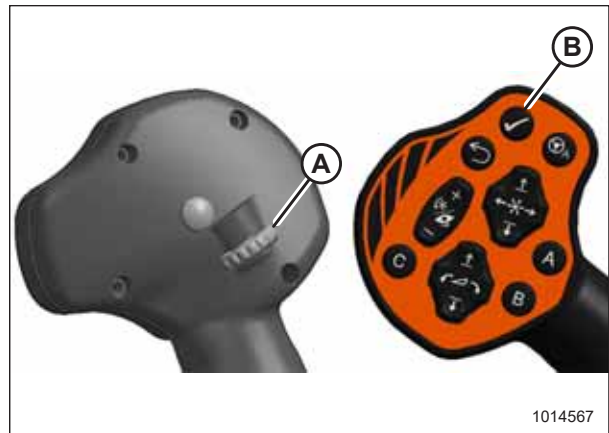

Figure 3.77: GSL Scroll Wheel and Select Button

Home, Back, and Select Buttons

- Press BACK button (A) on the Harvest Performance Tracker (HPT) to return to the previous level within the menu structure.
- Press HOME button (B) on the HPT to return to the last selected run screen (or header disengaged screen).



Figure 3.78: HPT Home and Back Buttons

- Press BACK button (A) on the ground speed lever (GSL) to return to the previous level within the menu structure.
- Press SHIFT button (B) on the back of the GSL, and then press GSL BACK button (A) to return to the last selected run screen (or header disengaged screen). Pressing SHIFT (B) and BACK (A) buttons on the GSL at the same time produces the same result as pushing the HOME key on the HPT display.

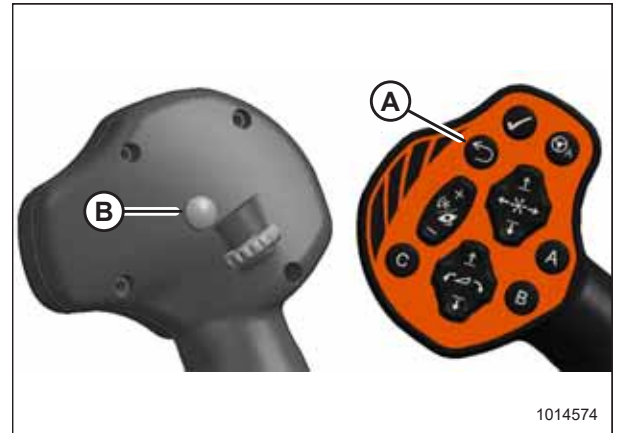

Figure 3.79: GSL Select and Back Buttons

Soft Keys

- Soft keys 1–4 (A) on the Harvest Performance Tracker (HPT) display run screens 1–4 respectively.
- Soft key 5 (B) displays the main menu.
- After a menu is open, soft keys 1–5 also function as buttons within menus.

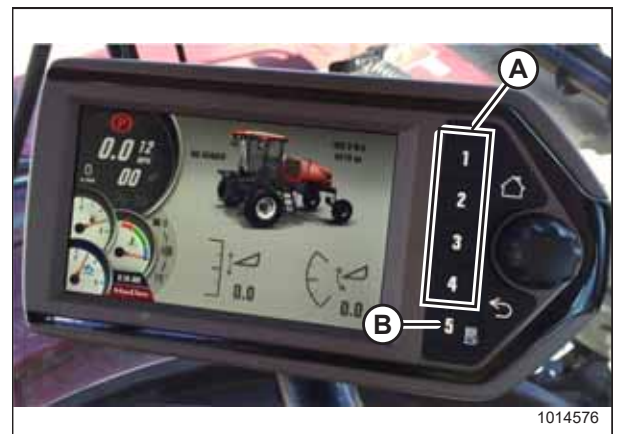

Figure 3.80: HPT Soft Keys

QuickMenu System

The QuickMenu system allows you to change certain windrower and header functions directly on the screen.

1. Press scroll knob (A) on the Harvest Performance Tracker (HPT) or SELECT button (B) on the ground speed lever (GSL) while in any run screen to open the QuickMenu system.

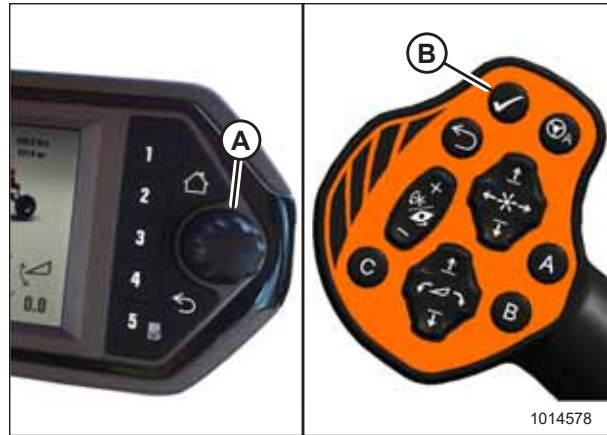

Figure 3.81: HPT Scroll Knob and GSL Select Button

2. Use the HPT scroll knob or the GSL scroll wheel to move red cursor (A) around the screen. The following selectable areas are highlighted in white and can be changed while in motion using the QuickMenu system:

- Ground speed limit (A) – For instructions, refer to [Adjusting Ground Speed Limit, page 130](#).
- EEC throttle limit (B) – For instructions, refer to [Programming the Eco Engine Control, page 124](#).
- Header float (C) – For instructions, refer to [Setting the Float, page 222](#).
- Header adjustments (when header is running [not shown]) – For instructions, refer to [4.7 Operating a Header, page 219](#).
- Knife speed – For instructions, refer to [4.8.7 Knife Speed, page 249](#), or [4.9.2 Knife Speed, page 269](#).
- Access maintenance information – For instructions, refer to [3.17.6 Machine Information Pages, page 100](#).
- Adjust auto speed settings – For instructions, refer to [4.8 Operating with D1X or D1XL Series Draper Header, page 234](#), [4.9 Operating with an A40DX Auger Header, page 262](#), or [4.11 Operating with an R113 or R216 Rotary Disc Header, page 285](#).
- Define header alarm speeds – For instructions, refer to [4.8 Operating with D1X or D1XL Series Draper Header, page 234](#), or [4.9 Operating with an A40DX Auger Header, page 262](#).
- Header Alarm pressure – For instructions, refer to [4.8 Operating with D1X or D1XL Series Draper Header, page 234](#), [4.9 Operating with an A40DX Auger Header, page 262](#), [4.11 Operating with an R113 or R216 Rotary Disc Header, page 285](#).



Figure 3.82: QuickMenu System

OPERATOR'S STATION

- Manage telltales – For instructions, refer to *Faults and Telltales, page 88*.
 - Turn auto speeds ON/OFF – For instructions, refer to *4.8 Operating with D1X or D1XL Series Draper Header, page 234*, or *4.9 Operating with an A40DX Auger Header, page 262*.
3. Place the red cursor (red border [A]) over the function you want to adjust, and press the HPT scroll knob or GSL SELECT button to display a submenu containing the adjustable values within the selected function.

Main Menu

The main menu provides access to submenus for viewing and adjusting windrower and header settings.

To display the main menu and select functions, follow these steps:

1. Press soft key 5 (A) to open the main menu or press SHIFT and SELECT on the ground speed lever.
2. Use Harvest Performance Tracker (HPT) scroll knob (B) or the ground speed lever (GSL) scroll wheel (not shown) to place red cursor (C) over the icon you want to select.

NOTE:

Using scroll knob will activate titles that explain each selection.

3. Press HPT scroll knob (B) or the GSL SELECT button (not shown) to select the highlighted icon.

NOTE:

Pressing the corresponding soft key will also work.

The following submenus are accessible through the main menu:

- Information
- Settings
- Maintenance
- Diagnostics
- Engine aftertreatment

For instructions on navigating the submenus, refer to *Menu Icons, page 84*.

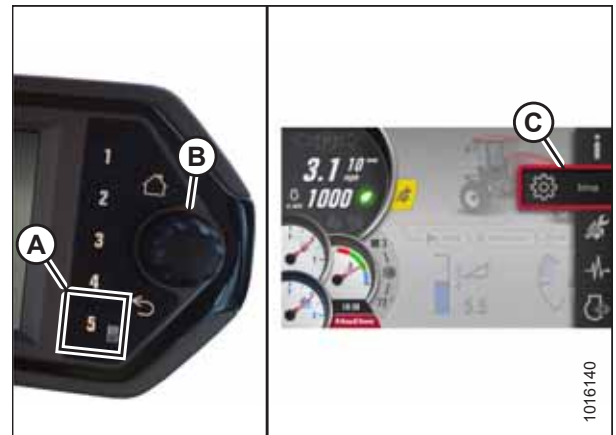

Figure 3.83: Opening the Main Menu

Menu Icons

Several menu icons are available in the main menu. Selecting a menu icon will open submenu icons, menu lists, and radio buttons for viewing and adjusting windrower and header settings.

Information: Icon (A) displays the following submenu icons:

- Windrower Information (B)
- Header Information (C)
- Module Information (D)
- Performance Information (E)

NOTE:

Header Information (C) has a hidden menu allowing Dealers to modify the stored list of headers. To access, hold the EEC button for 5 seconds while on the Header Information page.

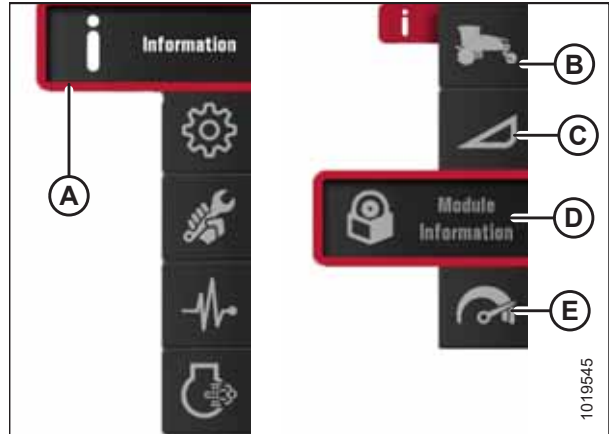

Figure 3.84: Information Icon and Information Submenu Icons

Setup: Icon (A) displays the following submenu icons:

- Screen Settings (B)
- Windrower Settings (C)
- Header Setup (D)
- One-Touch-Return Settings (E)

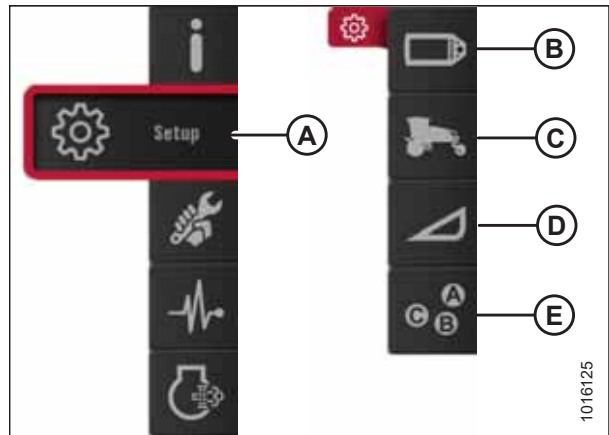

Figure 3.85: Settings Icon and Settings Submenu Icons

Screen Settings: Icon (A) displays the following submenu icons:

- Brightness and Volume (B)
- Time and Date (C)
- Language and Units (D)
- Reset to Defaults (E)

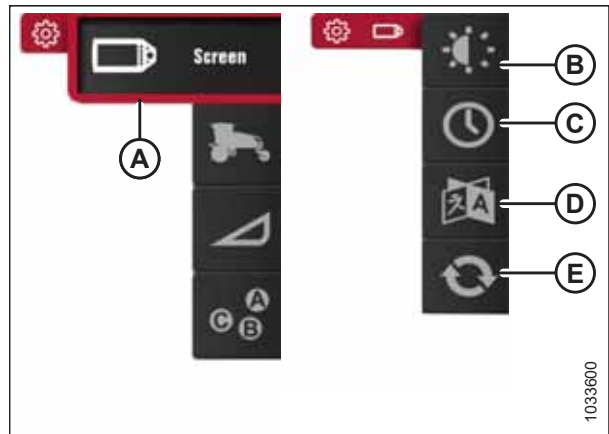

Figure 3.86: Screen Settings Icon and Display Settings Submenu Icons

OPERATOR'S STATION

Windrower Settings: Icon (A) displays the following submenu icons:

NOTE:

The F3 shortcut button on the operator's console also displays the windrower settings menu.

- Calibration (B)
- Tires (C)
- Lockout Functions (D)
- Sensors (E)

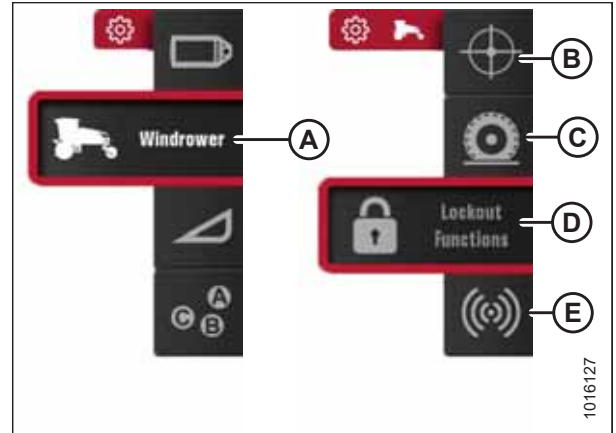

Figure 3.87: Windrower Settings Icon and Windrower Settings Submenu Icons

Header Setup: Icon (A) opens the SET-UP HEADER menu list.

NOTE:

The F4 shortcut button on the operator's console also displays the SET-UP HEADER menu list.

- Header Type (B)
- Hours Used (C)
- Total Acres (D)

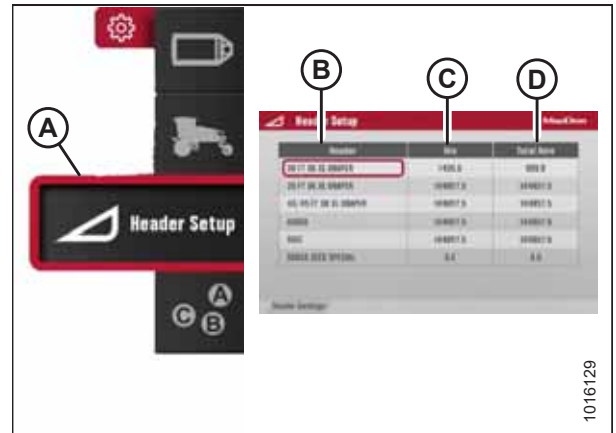

Figure 3.88: Header Setup Icon and Menu List

After the header is selected, the HEADER SETUP menu opens, which includes:

- Cut Width
- Raise/Lower Rates
- Attachments



Figure 3.89: Header Setup Menu

OPERATOR'S STATION

One-Touch-Return: Icon (A) displays the One-Touch-Return menu list.

NOTE:

The F2 shortcut button on the operator's console also displays the One-Touch-Return menu list.



Figure 3.90: One-Touch-Return Icon and One-Touch-Return Menu List

Maintenance: Icon (A) opens the maintenance menu list (B). For instructions, refer to [5.2.3 Using the Electronic Maintenance Tool](#), page 301.

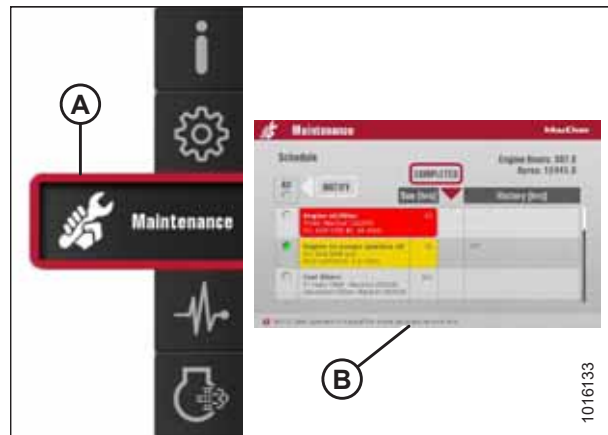

Figure 3.91: Maintenance Icon and Maintenance Menu List

OPERATOR'S STATION

Diagnostics: Icon (A) displays the following submenu icons:

- Windrower Fault Codes (B)
- Engine Fault Codes (C)
- Inputs/Outputs (D)
- Can Network (E)

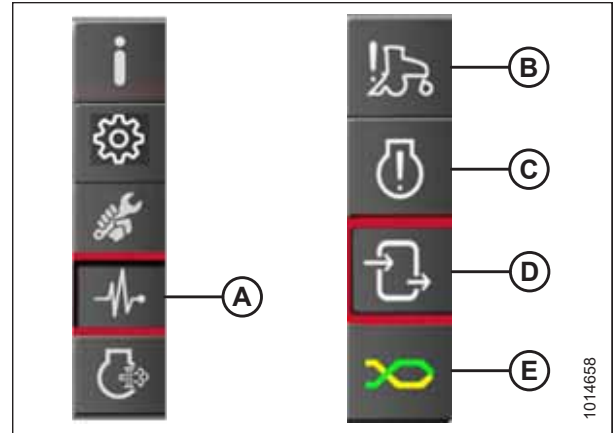

Figure 3.92: Diagnostics Icon and Diagnostics Submenu Icons

Engine Aftertreatment: Icon (A)

- Soft key 4 (B) activates the initiate manual SCR conditioning command, and initiate icon (D) will become highlighted on the display.
- Soft key 5 (C) activates the inhibit SCR conditioning command, and inhibit icon (E) will become highlighted on the display.

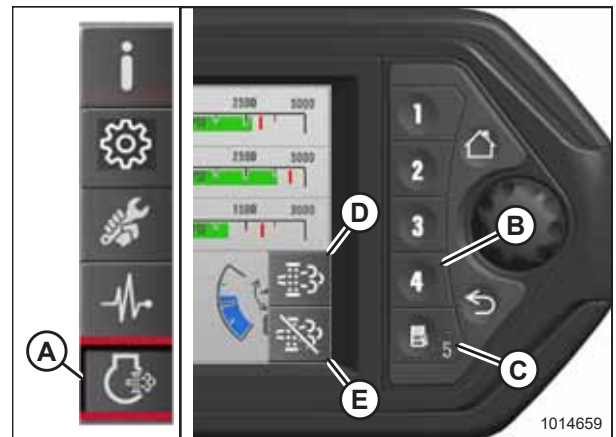

Figure 3.93: Engine Aftertreatment Icon and Soft Keys

OPERATOR'S STATION

Faults and Telltales

Faults and telltales displayed on the Harvest Performance Tracker (HPT) provide important information about the windrower and the engine. Telltales (A) include a symbol indicating the affected area (refer to [4.2 Symbol Definitions, page 108](#)) and a short description of fault (B).

- Red faults (displayed on the top line) indicate that a major fault has occurred and will cause progressive damage or affect the safe operation of the machine. The machine should be shut down as soon as possible.
- Yellow faults (displayed on the bottom line) indicate that a failure has occurred, and the machine should be serviced as soon as possible to diagnose the failure.

To display a more detailed fault page, use HPT scroll knob (E) to select question mark symbol (C).

To close short description (B), use HPT scroll knob (E) to select close symbol (D). Telltales (A) remain on the screen until the fault is corrected.

NOTE:

Closing the short description of a yellow fault will mute the alarm tone associated with that fault. Alarm tones associated with red faults cannot be muted.

NOTE:

For instructions on clearing fault codes, refer to [Clearing Fault Codes, page 94](#).

Figure 3.94: HPT Run Screen Displaying Faults



OPERATOR'S STATION

If multiple faults are detected, the number of faults will appear in the corner of telltale icon (A).



Figure 3.95: Telltale Icon – Multiple Faults Detected

Using the HPT scroll/select knob, select the question mark symbol next to the short description to display a detailed description of the fault. If there are multiple faults, telltale icons (A) will appear on screen in a row. To display a detailed description of each fault, use the HPT scroll/select knob to select the icon.

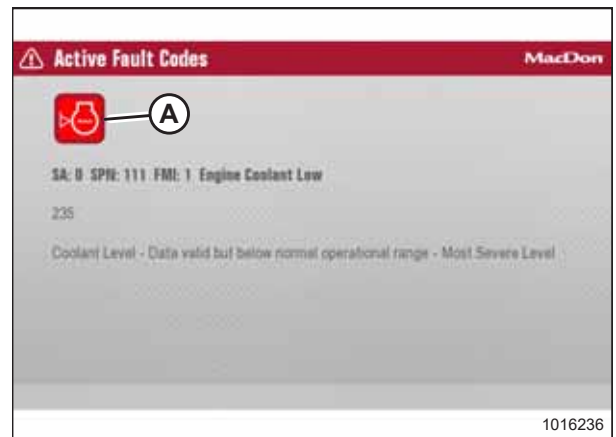

Figure 3.96: HPT Fault Description Page

3.17.3 Setting up the Harvest Performance Tracker Screen

The screen menu configures the Harvest Performance Tracker (HPT) display and volume settings, and resets the HPT to factory defaults.

The following settings should be checked before initial operation of the windrower:

- Brightness and volume
- Time and date
- Language and units of measurement

The key must be turned to the ON position to enter the setup menu, but the engine does not have to be running.

Setting Screen Brightness

Screen brightness is shown with a 10-segment bar graph and is adjustable down to 10%. The brightness automatically adjusts for daytime and nighttime operation. Day mode is defined as having the headlights or work lights OFF (or having only the clearance lights ON). Night mode is defined as having either the headlights or work lights ON.

Follow this procedure to adjust the factory-set screen brightness:

1. Navigate to the SETTINGS menu with soft key 5 and the Harvest Performance Tracker (HPT) scroll knob. For instructions, refer to [3.17.2 Navigating the Harvest Performance Tracker Display, page 80](#) if required.
2. Scroll to SCREEN icon (A) and select it.
3. Scroll to BRIGHTNESS AND VOLUME icon (B), and select it to open the adjustment window.

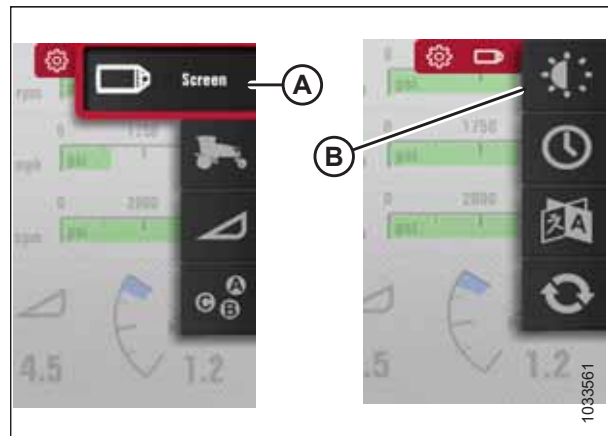

Figure 3.97: Brightness and Volume

4. Scroll through the following four brightness modes, and select the mode that requires adjustment:
 - DAY mode (A) (default setting is 70%)
 - NIGHT mode (B) (default setting is 20%)
 - KEYPAD DAY mode (C) (default setting is 70%)
 - KEYPAD NIGHT mode (D) (default setting is 20%)
5. Adjust the selected value by scrolling and previewing the brightness as you scroll.

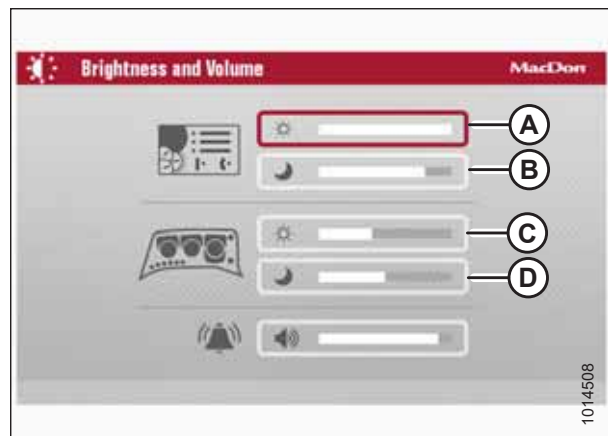

Figure 3.98: Brightness and Volume

Setting Alarm Volume

The volume control adjusts the audible alarms. It is depicted with a 10-segment bar graph and is adjustable down to 10%. The default volume is factory-set to 50%.

Adjust the volume as follows:

1. Navigate to SETTINGS Menu (C) with soft key 5 (A) and the HPT scroll knob (B). For instructions, refer to [3.17.2 Navigating the Harvest Performance Tracker Display, page 80](#) if required.

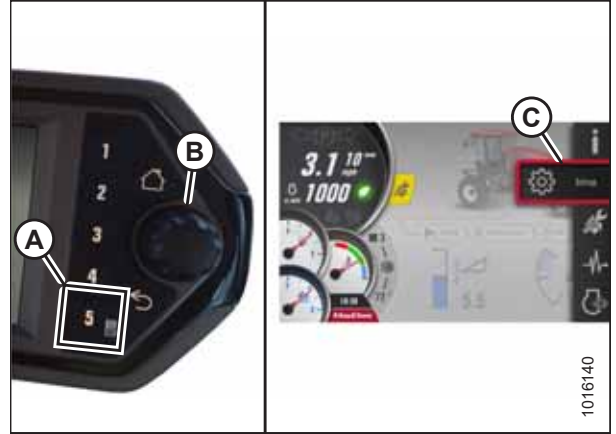

Figure 3.99: Main Menu

2. Scroll to SCREEN icon (A) and select it.
3. Scroll to BRIGHTNESS AND VOLUME icon (B), and select it to open the adjustment window.

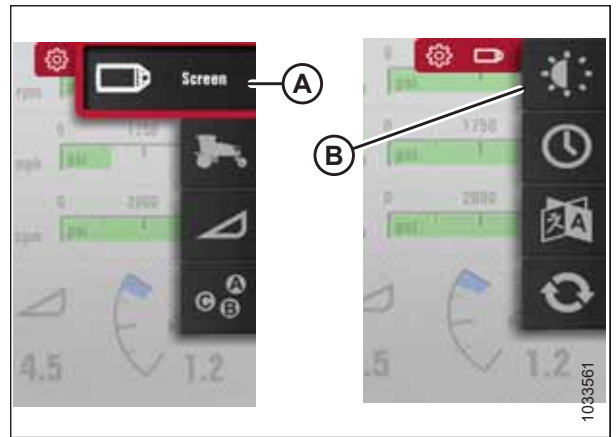

Figure 3.100: Brightness and Volume

4. Scroll to VOLUME option (A) and select it.
5. Adjust the volume by scrolling.



Figure 3.101: Brightness and Volume

Setting Time and Date

Whenever the Harvest Performance Tracker (HPT) boots up, the time and date will display according to your selected configuration.

1. Navigate to the SETTINGS menu with soft key 5 and the HPT scroll knob. For instructions, refer to [3.17.2 Navigating the Harvest Performance Tracker Display, page 80](#).
2. Scroll to SCREEN option (A) and select it.
3. Scroll to TIME AND DATE option (B), and select it to open the adjustment window.



Figure 3.102: Time and Date

4. Scroll through the available options on the HPT display, select the desired option, and scroll to adjust.



Figure 3.103: Time and Date

Setting Language and Units of Measurement

To set the language and units of measurement displayed, follow these steps:

1. Navigate to the SETTINGS menu with soft key 5 and the Harvest Performance Tracker (HPT) scroll knob. For instructions, refer to [3.17.2 Navigating the Harvest Performance Tracker Display, page 80](#).
2. Scroll to SCREEN icon (A) and select it.
3. Scroll to LANGUAGE AND UNITS icon (B), and select it to open the adjustment window.

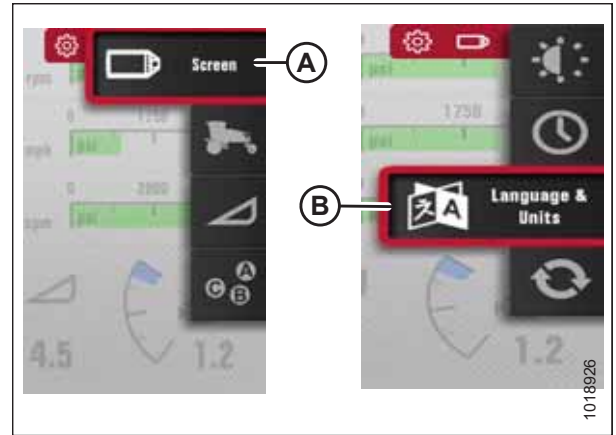

Figure 3.104: Language and Units

4. Scroll through the available options on the HPT, select desired item, and scroll to adjust:

LANGUAGE

- ENGLISH (default)
- SPANISH

UNITS

- METRIC
- USA (default)

Refer to [8.2 Conversion Chart, page 467](#) for a comprehensive list of U.S. and metric units.

OPERATOR'S STATION

Clearing Fault Codes

The lists of inactive fault codes stored on the Harvest Performance Tracker (HPT) can be cleared using the operator console.

1. Turn the ignition key to the ACC or RUN position. Make sure the engine is not running.

NOTE:

You cannot clear fault codes if the engine is running, or if there are any active fault codes.

2. Press soft key 5 (A) to open the main menu or press SHIFT and SELECT on the ground speed lever (GSL).
3. Use the Harvest Performance Tracker (HPT) scroll knob (B) or the GSL scroll wheel (not shown) to place red cursor (C) over the diagnostics icon

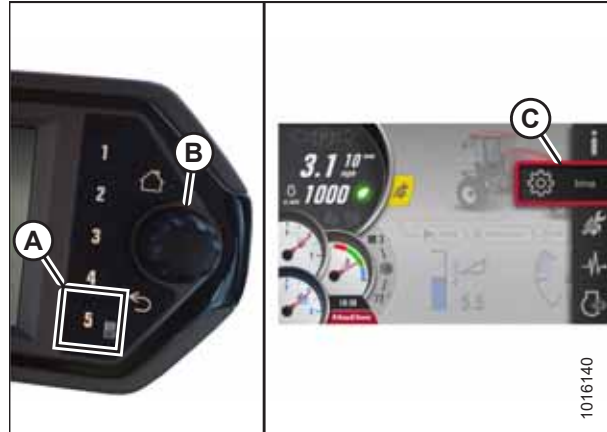

Figure 3.105: Opening the Main Menu

4. Scroll to windrower fault codes (A) or engine fault codes (B) and select it to open the fault window.
5. Verify on the screen that there are no active error messages. You must resolve all active fault codes before you can clear the fault codes.

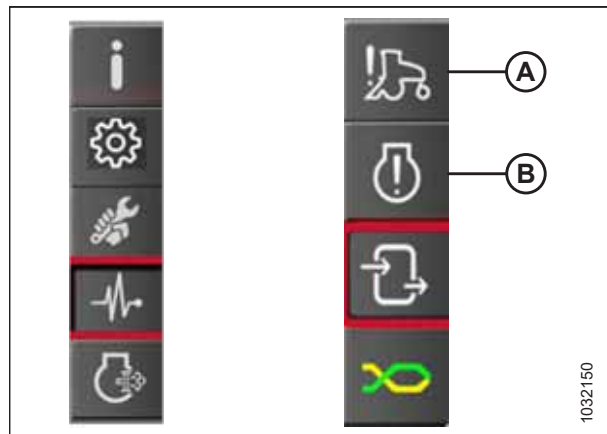

Figure 3.106: Diagnostics Icon and Diagnostics Submenu Icon

OPERATOR'S STATION

6. Press and hold eco engine control button (A) for 5 seconds. The CONFIRM YES/NO dialog box is displayed.
7. Select YES to save changes and close the dialog box, or select NO to close the dialog box without saving changes.

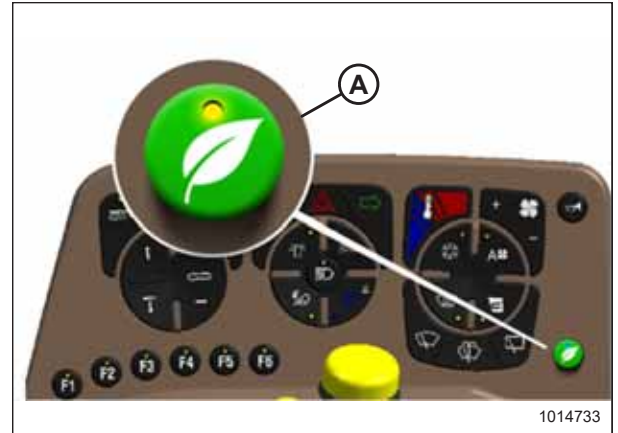

Figure 3.107: Eco Engine Control (EEC) Button

OPERATOR'S STATION

Resetting to Factory Defaults

To change any Harvest Performance Tracker (HPT) settings back to the defaults set in the factory, follow these steps:

1. Press soft key 5 (A), and use HPT scroll knob (B) or the ground speed lever (GSL) scroll wheel (not shown) to place the red cursor over SETTINGS icon (C).
2. Press HPT scroll knob (B) or the GSL SELECT button (not shown) to activate main menu (C) options.

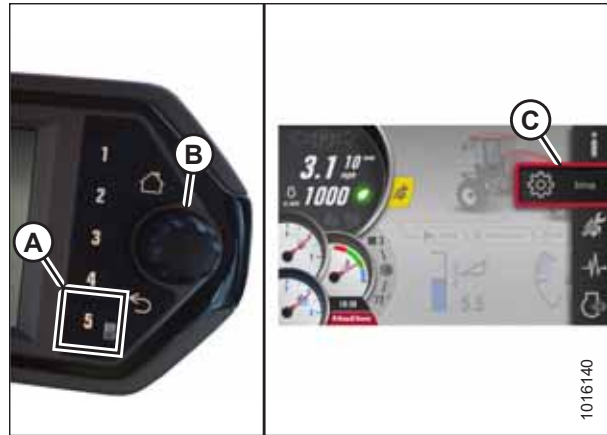

Figure 3.108: Opening the Main Menu

3. Scroll to DISPLAY SETTING icon (A) and press SELECT.
4. Scroll to RESET TO DEFAULTS icon (B), and press SELECT to open the adjustment window.

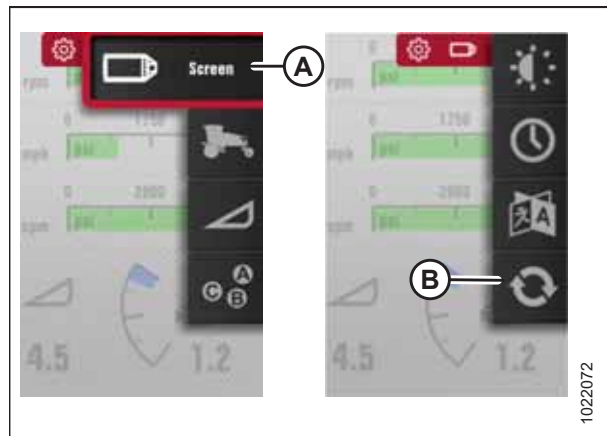

Figure 3.109: Opening the Reset to Defaults Page

OPERATOR'S STATION

5. Scroll through the available options, and press SELECT to reset to default. Refer to the following list for factory default options:
 - Select all
 - Display brightness
 - Keypad brightness by day
 - Display volume
 - Language (English)
 - Units (USA)
 - Eco engine control speed (4 and 6 cylinders have different speeds)
 - Max cab-forward speed 14 mph
 - Max engine-forward speed 27 mph
 - Header speed settings
 - Header alarm pressures
 - Knife alarm speed
 - Manual (not auto) knife speed mode
 - Manual (not auto) reel speed mode
 - Manual (not auto) draper speed mode
 - All functions unlocked
 - All sensors enabled
 - Cut width
 - Swath roller selection off
 - Max header raise/lower rates
 - One-touch-return presets (reset to default option available also within this menu)
 - DWA speed
 - DWA alarm pressure
6. Press the HOME or BACK button. The CONFIRM YES/NO dialog box is displayed.
7. Select YES to save changes and close the dialog box, or select NO to close the dialog box without saving changes.

3.17.4 Setting Windrower Tire Size

The Harvest Performance Tracker (HPT) is factory-set for 600/65R28 bar tires. If the windrower has a different tire type, you need to change this setting. Setting the proper tire size is important for accurate tracking of ground speed, acres, and productivity data.

1. Navigate to the SETTINGS menu with soft key 5 and the HPT scroll knob. For instructions, refer to [3.17.2 Navigating the Harvest Performance Tracker Display, page 80](#).
2. Scroll to WINDROWER SETTINGS icon (A) and select it.
3. Scroll to TIRES icon (B), and select it to display the adjustment window.

NOTE:

The F3 shortcut button on the operator's console will also display the WINDROWER SETTINGS menu.

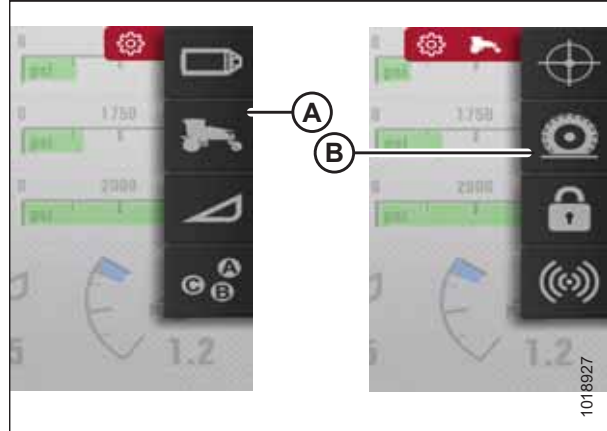

Figure 3.110: Tire Size

4. Scroll to highlight the appropriate tire size (A) and select it. The new selection will be displayed with a shaded green radio button.
5. If optional high torque final drives are installed, scroll to the power wheel option and select HIGH TORQUE FINAL DRIVES (B). The new selection will be displayed with a shaded green radio button.

NOTE:

Do **NOT** select this option unless the high torque (36.82:1) final drives are installed.

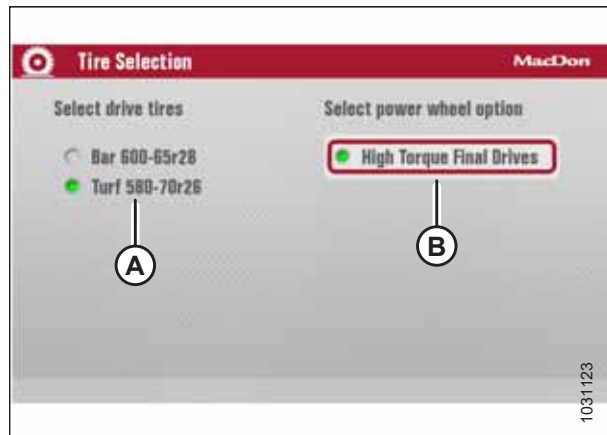

Figure 3.111: Tire Selection

3.17.5 Activating Control Locks

All header functions are factory-set to the unlocked position, but certain functions can be locked to prevent changes. This feature can be used to maintain preferred settings when there are multiple Operators.

1. Press soft key 5 (A) to display the main menu.
2. To scroll to setting icon (C), use the Harvest Performance Tracker (HPT) scroll knob (B) or the ground speed lever (GSL) scroll wheel (not shown).
3. Press HPT scroll knob (B) or the GSL SELECT button (not shown) to activate the settings menu options.

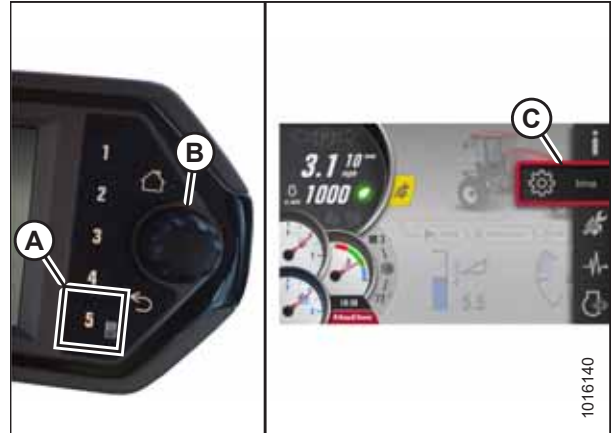

Figure 3.112: Displaying the Main Menu

4. Scroll to WINDROWER SETTINGS icon (A) and press SELECT.
5. Scroll to CONTROL LOCKS icon (B), and press SELECT to display the adjustment window.

NOTE:

The F3 shortcut button on the operator's console will also display the windrower settings menu.

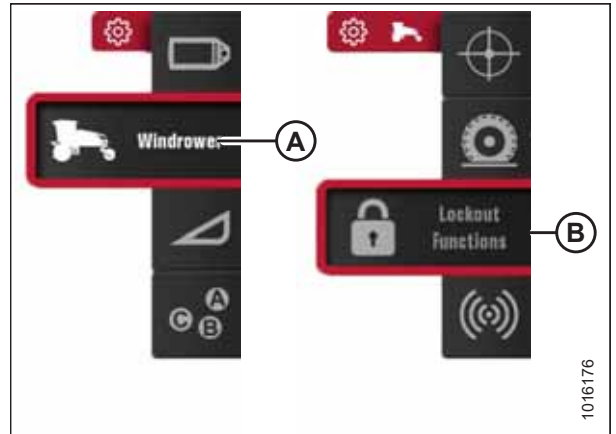

Figure 3.113: Windrower Settings Icon and Tires Submenu Icon

6. On the LOCKOUT FUNCTIONS page, use the scroll knob on the HPT to move cursor (A) to the desired function(s) to lock.
7. Press SELECT to activate the lock.

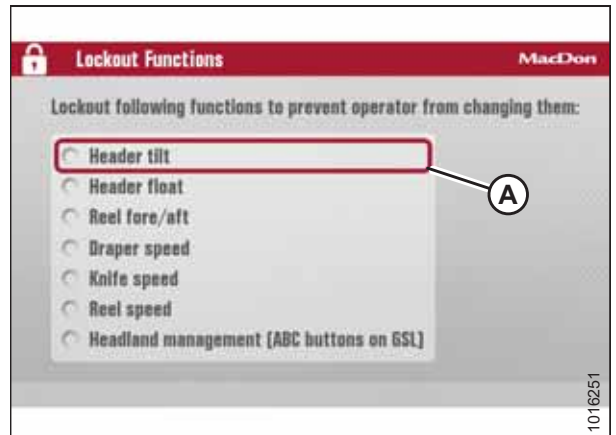

Figure 3.114: Lockout Functions Page

3.17.6 Machine Information Pages

Selecting the INFORMATION icon (A) from the main menu provides access to the following submenu icons:

- Windrower information (B) – Refer to *Accessing Windrower Information, page 100*.
- Header information (C) – Refer to *Accessing Header Information, page 101*.
- Software information (D) – Refer to *Accessing Software Information, page 102*.
- Performance information (E) – Refer to *Accessing Performance Information, page 103*.

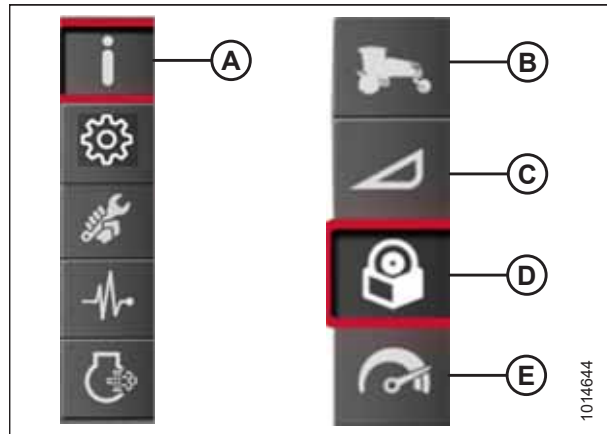

Figure 3.115: Information Icon and Information Submenu Icons

Accessing Windrower Information

To access information about the windrower on the Harvest Performance Tracker (HPT) display, follow these steps:

1. Press soft key 5 (A) to open the main menu.
2. To scroll to INFORMATION icon (C), use Harvest Performance Tracker (HPT) scroll knob (B) or the ground speed lever (GSL) scroll wheel (not shown).
3. Press HPT scroll knob (B) or the GSL SELECT button (not shown) to select the highlighted INFORMATION icon.



Figure 3.116: Opening the Main Menu

4. Scroll to WINDROWER INFORMATION submenu icon (A), and press SELECT to display the windrower information menu.

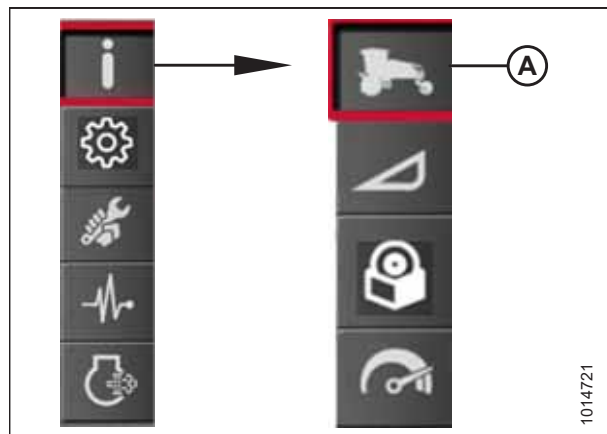

Figure 3.117: Windrower Information Submenu Icon

OPERATOR'S STATION

The windrower information menu displays the following information:

- Engine hours (A)
- Windrower total hours (B)
- Total acres (C)
- Windrower total header hours (D)

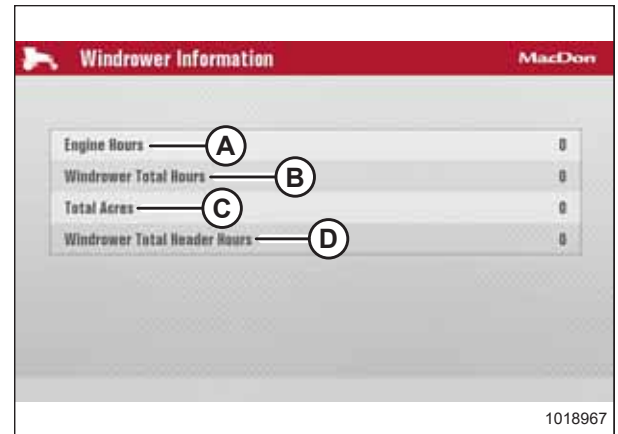

Figure 3.118: Windrower Information Menu

Accessing Header Information

To access information about the header on the Harvest Performance Tracker (HPT) display, follow these steps:

1. Press soft key 5 (A) to open the main menu.
2. To scroll to INFORMATION icon (C), use HPT scroll knob (B) or the ground speed lever (GSL) scroll wheel (not shown).
3. Press HPT scroll knob (B) or the GSL SELECT button (not shown) to select the highlighted INFORMATION icon.



Figure 3.119: Opening the Main Menu

4. Scroll to HEADER INFORMATION submenu icon (A), and press SELECT to display the header information menu.

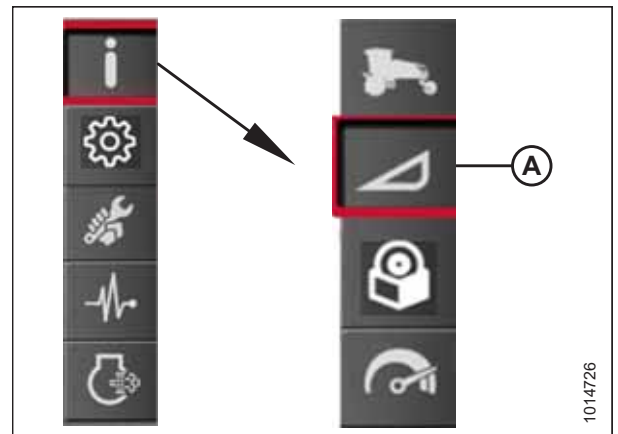

Figure 3.120: Header Information Submenu Icon

OPERATOR'S STATION

5. The header information menu displays the following information:

- Header (A)
- Header hours (B)
- Total acres (C)
- Sub acres (D) (resettable)

NOTE:

If you select any particular value (E), the message RESET YES/NO appears on the display. Select YES to reset the sub acres to zero and return to the same highlighted sub acres. Select NO or press the BACK or HOME button to dismiss the message without resetting the sub acres. The sub acres are also resettable from run screen 3. For instructions, refer to [Viewing Performance Data, page 138](#).

Header	Hours	Total Acres	Sub Acres
D130 XL	104857.5	259100.1	259100.1
D135 XL	104857.5	259100.1	259100.1
D140/D145 XL	104857.5	259100.1	259100.1
GSS Auger	104857.5	259100.1	259100.1
Auger	104857.5	259100.1	259100.1
Disc	104857.5	259100.1	259100.1

Select to set "Sub Acres" value to zero.

Figure 3.121: Header Information Menu

Accessing Software Information

To access software information on the Harvest Performance Tracker (HPT) display, follow these steps:

1. Press soft key 5 (A) to open the main menu.
2. To scroll to INFORMATION icon (C), use HPT scroll knob (B) or the ground speed lever (GSL) scroll wheel (not shown).
3. Press HPT scroll knob (B) or the GSL SELECT button (not shown) to select the highlighted INFORMATION icon.



Figure 3.122: Opening the Main Menu

4. Scroll to SOFTWARE INFORMATION submenu icon (A), and press SELECT to display the module information menu.

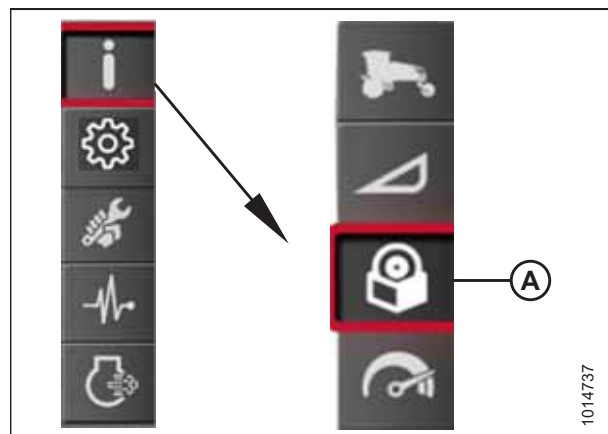
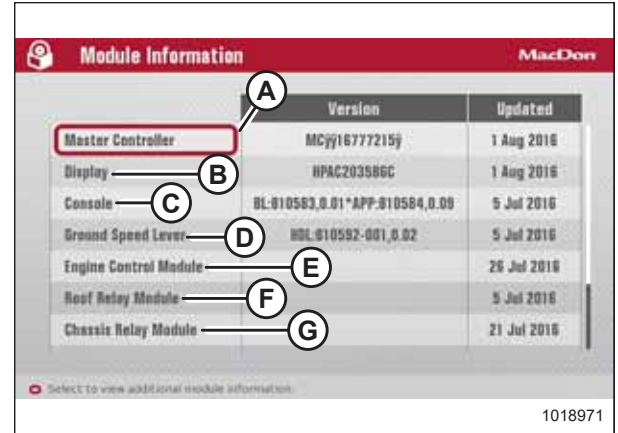

Figure 3.123: Software Information Submenu Icon

OPERATOR'S STATION

The HPT display reports the component make, software ID, and software installation date in the software information menu. In addition, the software versions and make, model, and serial numbers of the following modules are also displayed on the screen:

- Master controller (A)
- Display (B)
- Console (C)
- Ground speed lever (D)
- Engine control module (E)
- Roof relay module (F)
- Chassis relay module (G)
- HVAC module (not shown)
- Firewall extension module (not shown)



Module Information		MacDon
	Version	Updated
Master Controller	MCjy16777215j	1 Aug 2016
Display	HPAC203586C	1 Aug 2016
Console	BL:810583,0.01*APP:810584,0.08	5 Jul 2016
Ground Speed Lever	NBL:810582-001,0.02	5 Jul 2016
Engine Control Module		26 Jul 2016
Roof Relay Module		5 Jul 2016
Chassis Relay Module		21 Jul 2016

SELECT to view additional module information

1018971

Figure 3.124: Software Information Menu

Accessing Performance Information

To access information on the Harvest Performance Tracker (HPT) about how the machine has performed to date, follow these steps:

1. Press soft key 5 (A) to open the main menu.
2. To scroll to INFORMATION icon (C), use Harvest Performance Tracker (HPT) scroll knob (B) or the ground speed lever (GSL) scroll wheel (not shown).
3. Press HPT scroll knob (B) or the GSL SELECT button (not shown) to select the highlighted INFORMATION icon.



Figure 3.125: Opening the Main Menu

OPERATOR'S STATION

4. Scroll to WINDROWER PERFORMANCE submenu icon (A), and press SELECT to display the performance information menu.

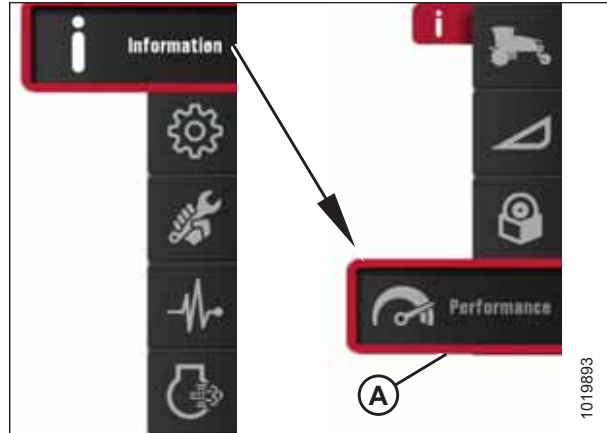

Figure 3.126: Performance Information Submenu Icon

The performance information menu displays two columns: one column displays the accumulated data over the machine's lifetime (A) and is not resettable, the other displays the data accumulated per field (B) and is resettable.

The performance information menu displays the following information:

- Engine hours (C)
- Engine % idle time (D)
- Average % load (E)
- Gal/Hr (F)
- Acres (G)
- Acres/Gal (H)
- Gal/Acre (J)
- Windrower header hours (K)

	Lifetime	Field
Engine Hours (C)	429486729.5	429486729.5
Engine % Idle Time (D)	50	---
Average % Load (E)	8554	---
Gal/Hr (F)	173.1	173.1
Acres (G)	1061307893.4	1061307893.4
Acres/Hr (H)	1619.4	1619.4
Gal/Acre (J)	70.06	70.06
Windrower Header Hours (K)	429486729.5	429486729.5

Select to set all "Field" values to zero.

Figure 3.127: Performance Information Menu

NOTE:

To reset all of the field values to zero, use the scroll knob to highlight the FIELD column (B) and press the SELECT button.

3.17.7 F1 to F6 Function Buttons

The following functions have been assigned to the function buttons on the operator's console:

- **F1 (A)** – Float menu
- **F2 (B)** – One-Touch-Return
- **F3 (C)** – Windrower settings
- **F4 (D)** – Header settings
- **F5 (E)** – Conditioner baffle raise^{6,7}
- **F6 (F)** – Conditioner baffle lower^{6,7}

Press a function button to override the existing screen and display the function.

Press the function button again or press the Back button to return to the previous screen.

Press the Home button to return to the run screen.



Figure 3.128: Operator's Console Shortcut Buttons

6. If a button is pressed momentarily the baffle will move approximately 3 mm (0.12 in).

7. Available as an option on the R216. Order MD #B6664.

Chapter 4: Operation

4.1 Owner/Operator Responsibilities



CAUTION

- It is your responsibility to read and understand this manual completely before operating the windrower. Contact your Dealer if an instruction is not clear to you.
- Follow all safety messages in the manual and on safety signs on the machine.
- Remember that YOU are the key to safety. Good safety practices protect you and the people around you.
- Before allowing anyone to operate the windrower, for however short a time or distance, make sure they have been instructed in its safe and proper use.
- Review the manual and all safety related items with all Operators every year.
- Be alert for other Operators not using recommended procedures or not following safety precautions. Correct these mistakes immediately, before an accident occurs.
- Do NOT modify the machine. Unauthorized modifications may impair the function and/or safety and affect machine life.
- The safety information given in this manual does NOT replace safety codes, insurance needs, or laws governing your area. Be sure your machine meets the standards set by these regulations.

4.2 Symbol Definitions

The following symbols are used to depict functions or reactions of the various instruments and controls.

Learn the meaning of these symbols before operating the windrower.

4.2.1 Windrower Operating Symbols

These are the symbols used on the console for windrower operation.

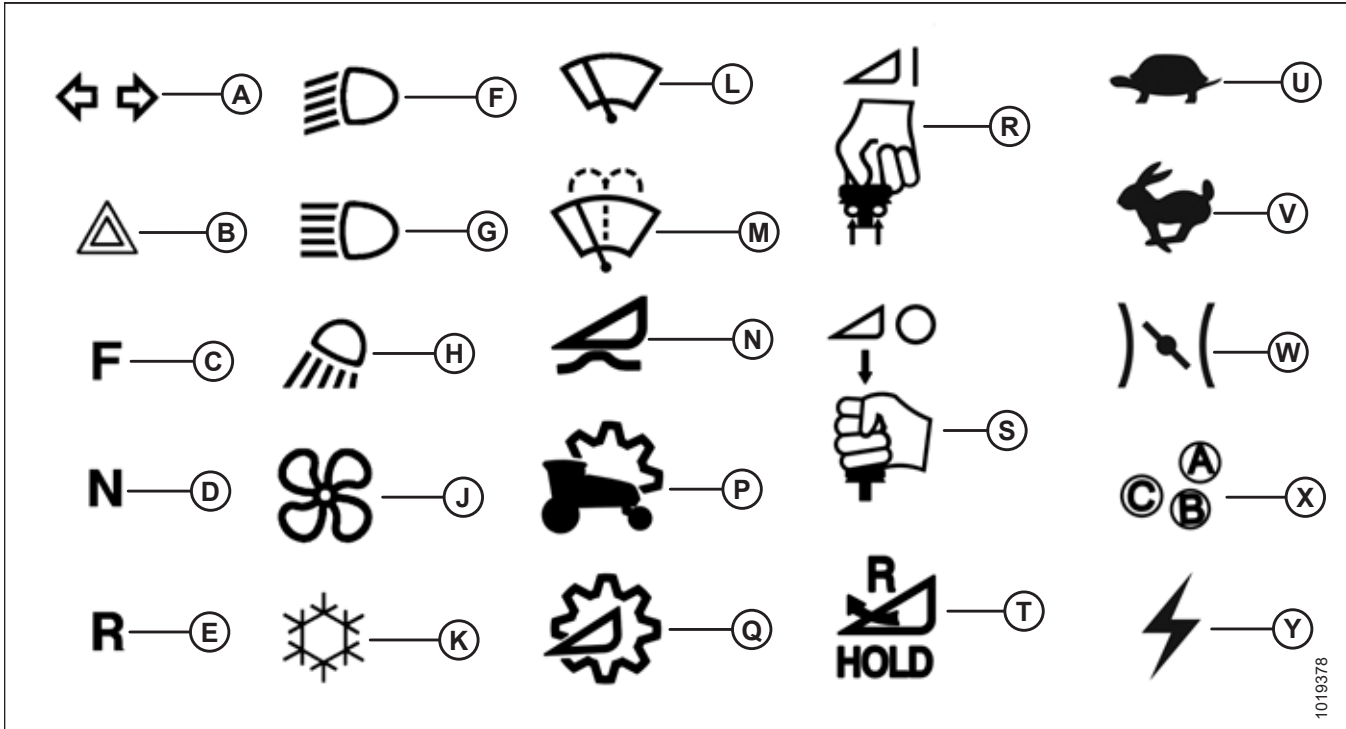

Figure 4.1: Windrower Operating Symbols

A - Signal Lights

D - Neutral

G - High Beams

K - Air Conditioning

N - Float Menu

R - Header Engage

U - Slow

X - One-Touch-Return

B - Hazard Lights

E - Reverse

H - Cab-forward Field Lights

L - Windshield Wiper

P - Windrower Settings

S - Header Disengage

V - Fast

Y - Electrical Power / Accessories

C - Forward

F - Road Lights

J - Blower Speed (Manual Mode)

M - Wiper Fluid

Q - Header Settings

T - Header Reverse

W - Engine Throttle

4.2.2 Harvest Performance Tracker Symbols

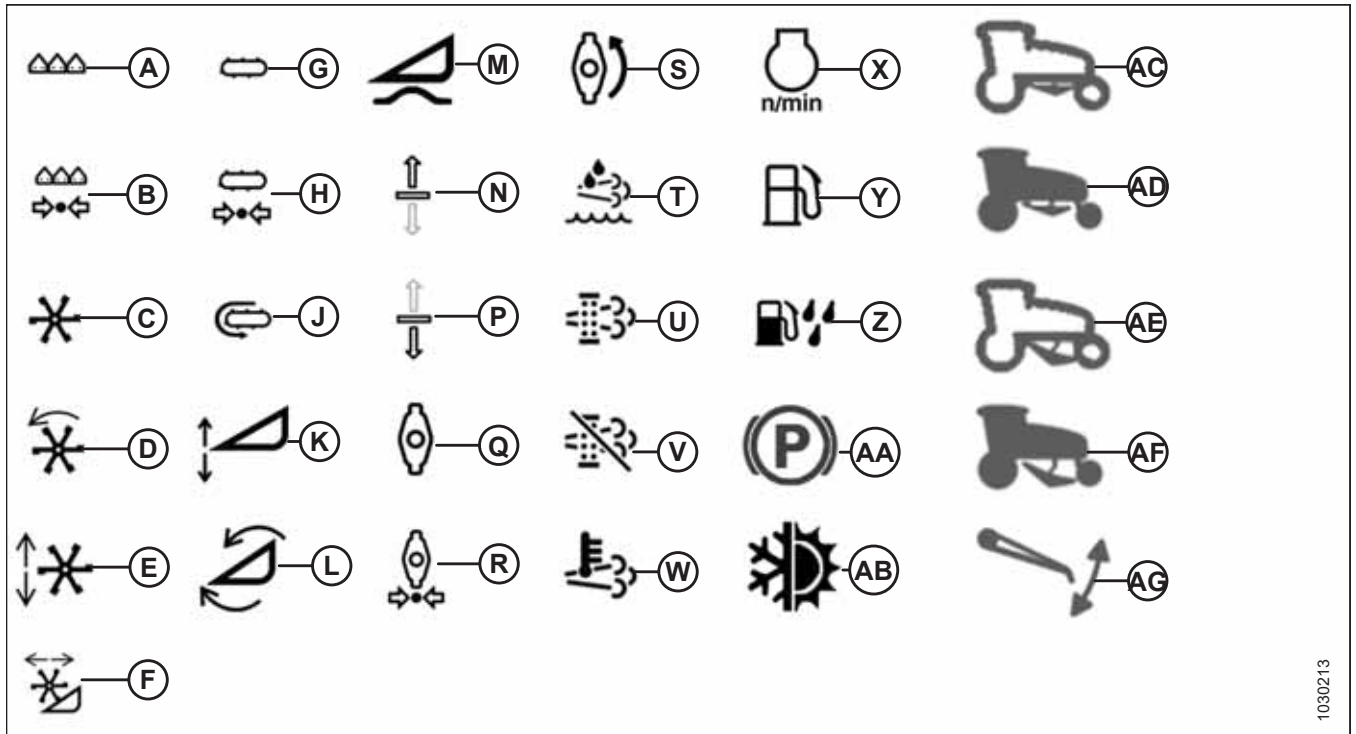
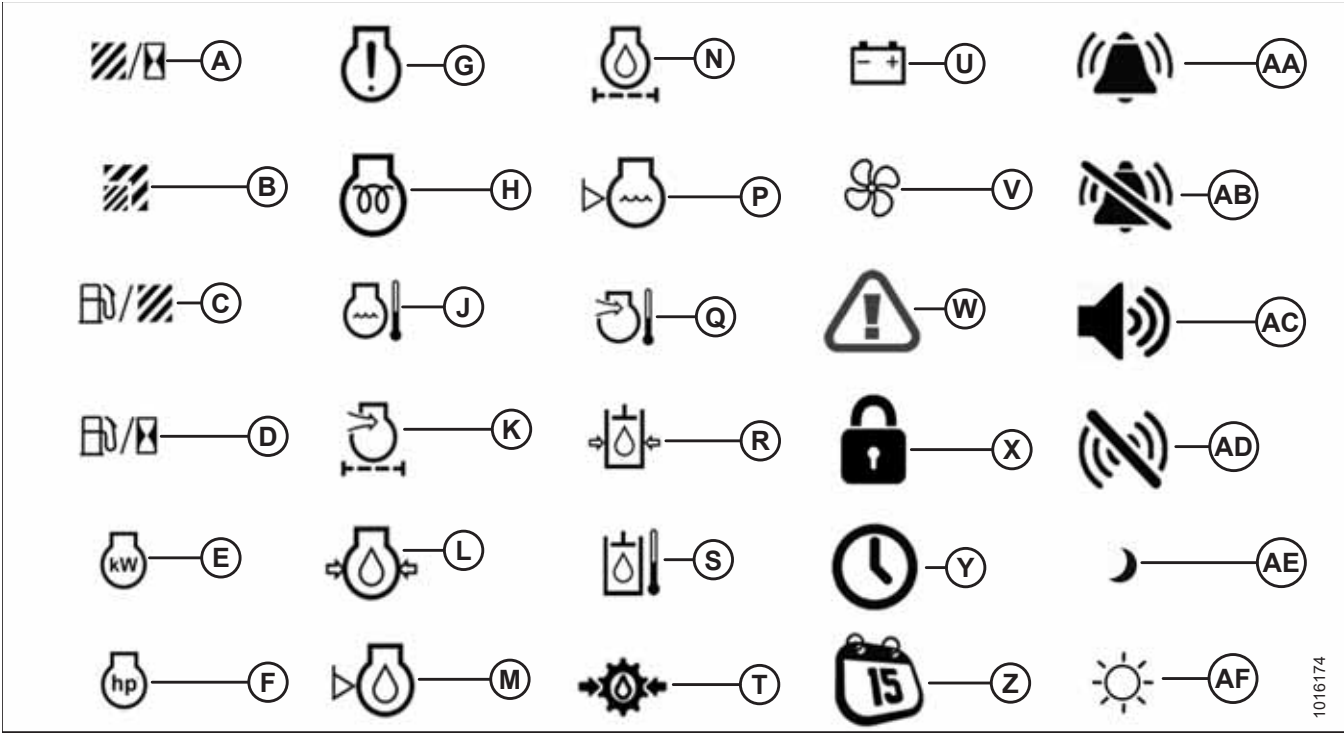

Figure 4.2: Harvest Performance Tracker (HPT) Symbols

- | | | |
|---|--------------------------------|-------------------------------------|
| A - Knife | B - Knife Pressure | C - Reel |
| D - Reel Speed | E - Reel Height | F - Reel Fore-Aft |
| G - Draper | H - Draper Pressure | J - Draper Speed |
| K - Header Height | L - Header Tilt | M - Header Float |
| N - DWA Raise | P - DWA Lower | Q - Disc |
| R - Disc Pressure | S - Disc Speed | T - DEF |
| U - SCR Conditioning Manual | V - SCR Conditioning Inhibit | W - High Exhaust System Temperature |
| X - Engine rpm | Y - Fuel | Z - Water in Fuel |
| AA - Parking Brake | AB - Climate Control | AC - Raising Swath Compressor |
| AD - Swath Compressor Raised | AE - Lowering Swath Compressor | AF - Swath Compressor Lowered |
| AG - Conditioner Baffle – Raise or Lower ⁸ | | |

8. Available as an option on the R216. Order MD #B6664.

OPERATION



1016174

Figure 4.3: HPT Symbols

- | | | |
|------------------------------|-------------------------------|-------------------------------------|
| A - Acres/Hour | B - Sub Acres | C - Fuel/Acre |
| D - Fuel/Hour | E - Engine Power Kilowatt | F - Engine Power Horsepower |
| G - Engine Malfunction | H - Wait to Start | J - Engine Coolant Temperature |
| K - Engine Intake Air Filter | L - Engine Oil Pressure | M - Engine Oil Level |
| N - Engine Oil Filter | P - Engine Coolant Level | Q - Engine Air Intake Temperature |
| R - Hydraulic Oil Pressure | S - Hydraulic Oil Temperature | T - Transmission Oil Pressure |
| U - Battery/Voltage | V - Fan Speed | W - Caution (Yellow) / Danger (Red) |
| X - Function Locked | Y - Time | Z - Date |
| AA - Alarm | AB - Alarm Off | AC - Volume Level |
| AD - Sensor Disabled | AE - Night | AF - Day |

4.3 Operating the Windrower

4.3.1 Operational Safety

CAUTION

Follow these safety precautions:

- Wear close-fitting clothing and protective shoes with slip-resistant soles.
- Remove foreign objects from the machine and surrounding area.
- Carry with you any protective clothing and personal safety devices that could be necessary through the day. **DO NOT** take chances. You may need:
 - A hard hat
 - Protective glasses or goggles
 - Heavy gloves
 - A respirator or filter mask
 - Wet weather gear
- Protect against noise. Wear suitable hearing protection such as ear muffs or ear plugs to protect against loud noises.
- Follow all safety and operational instructions given in your operator's manuals. If you do not have a header manual, get one from your Dealer and read it thoroughly.
- NEVER attempt to start the engine or operate the machine except from the operator's seat.
- Check the operation of all controls in a safe clear area before starting work.
- Check for excessive vibration and unusual noises. If there is any indication of trouble, shut down and inspect the machine. Follow proper shutdown procedure. For instructions, refer to [Shutting down the Engine, page 125](#).
- Operate only in daylight or good artificial light.



Figure 4.4: Safety Equipment



Figure 4.5: Safety Equipment

4.3.2 Break-in Period

From the factory the windrower is ready for normal operation. However, there are several items to check and watch out for during the first 150 hours.

DANGER

Before investigating an unusual sound or attempting to correct a problem, place ground speed lever (GSL) in PARK, shut off engine, and remove key.

IMPORTANT:

Until you become familiar with the sound and feel of your new windrower, be extra alert and attentive.

- Avoid unnecessary idling. If engine will be idling longer than 5 minutes after reaching operating temperature, turn ignition key OFF to stop the engine.
- Before taking the GSL out of PARK, let the hydraulic oil warm up to 32°C (90°F). You can view the hydraulic oil temperature on Run Screen 4 on the Harvest Performance Tracker (HPT) display. For instructions, refer to [Viewing Engine Cooling Data, page 128](#).
- Check engine oil level frequently. Watch for any signs of leakage. If oil must be added, refer to [Checking Engine Oil Level, page 117](#).
- Watch coolant gauge in cab for temperature rising beyond normal operating range. Check that coolant level at reserve tank (mounted next to radiator) stays between HOT and COLD marks on tank. For instructions, refer to [5.7.5 Checking Engine Coolant Level, page 341](#).

NOTE:

If overheating problems occur, check for coolant leaks.

- Perform the break-in inspections specified in [5.2.1 Break-in Inspection Schedule, page 298](#).

NOTE:

During the break-in period, a higher than usual oil consumption should be considered normal.

NOTE:

If windrower must be driven in cold weather (below freezing), let engine idle for 3 minutes, and then operate at moderate speed until oil has warmed up.

4.3.3 Preseason Checks / Annual Service

Follow these steps at the beginning of each season.

CAUTION

- Review the operator's manual to refresh your memory on safety and operating recommendations.
 - Review all safety signs and other decals on the windrower and note hazard areas.
 - Be sure all shields and guards are properly installed and secured. Never alter or remove safety equipment.
 - Be sure you understand and have practiced safe use of all controls. Know the capacity and operating characteristics of the machine.
 - Store a properly stocked first aid kit and charged fire extinguisher on the windrower.
1. Drain off excess hydraulic oil added for storage. For instructions, refer to [5.13.2 Draining Hydraulic Oil, page 382](#).
 2. Remove any plastic bags and/or tape from all sealed openings (air cleaner intake, exhaust pipe, fuel tank).
 3. Charge and install the batteries. Be sure the terminals are clean and cables are connected securely.
 4. Adjust the tension on the air conditioning (A/C) compressor belt. For instructions, refer to [5.6.5 Tensioning Air Conditioner Compressor Belts, page 326](#).
 5. Distribute A/C refrigerant by cycling the A/C switch. For instructions, refer to [Air Conditioning Compressor Coolant Cycling, page 114](#).
 6. Check the entire A/C system for leakage.
 7. Perform annual maintenance. For instructions, refer to [5.2 Windrower Break-In Inspections and Maintenance Schedule, page 298](#).

OPERATION

Air Conditioning Compressor Coolant Cycling

IMPORTANT:

Perform the following steps whenever the machine is first started after storage for more than one week:

1. Press the reduce (-) BLOWER SPEED switch (A) repeatedly until the lowest fan setting is reached.
2. Press the red area on TEMPERATURE CONTROL switch (F) repeatedly until maximum heating is reached.
3. Press A/C control (E) to OFF.
4. Start the engine.
5. Operate the windrower at low idle until the engine is warm.

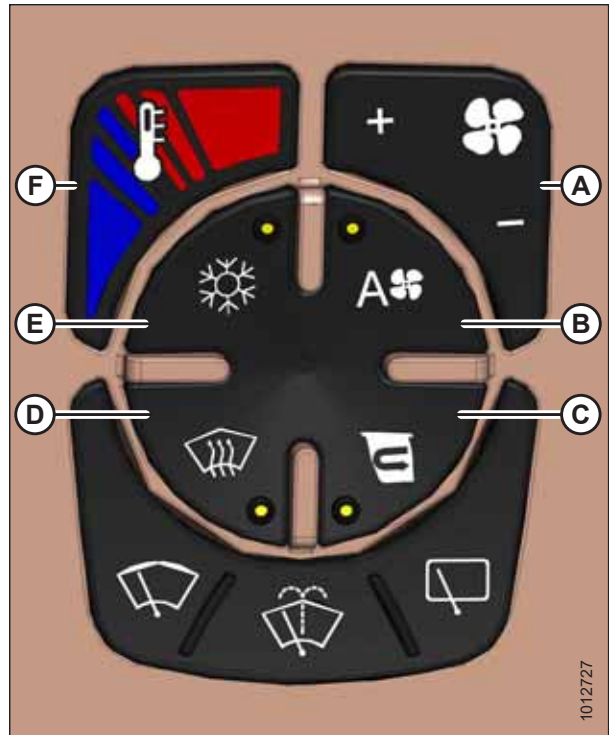

Figure 4.6: Climate Control

- | | |
|------------------------------|------------------------------|
| A - Blower Toggle Button | B - Outside Air Button |
| C - Recirculating Air Button | D - Windshield Defog/Defrost |
| E - Air Conditioning Button | F - Temperature Control |

4.3.4 Daily Checks and Maintenance

Perform the following checks and recommended maintenance before operating the windrower every day:

1. Check the machine for leaks.

NOTE:

Use proper procedure when searching for pressurized fluid leaks. For instructions, refer to [5.7.6 Hoses and Lines, page 342](#).

2. Check for missing or broken parts.
3. Clean the windows and mirrors to ensure good visibility in all directions. Stand on the platform to access the rear window. Hold onto the handholds on the cab front corners and stand on the header anti-slip strips to wash the front window.
4. Clean all lights and reflective surfaces to maintain visibility to others.
5. Perform daily maintenance. For instructions, refer to [5.2 Windrower Break-In Inspections and Maintenance Schedule, page 298](#).

Filling Fuel Tank

The symbol inside the fuel gauge on the Harvest Performance Tracker (HPT) display will signal the Operator when the fuel level is low. Fill fuel tank daily, preferably at the end of the day's operation to help prevent condensation in the tank.



WARNING

To avoid bodily injury or death from unexpected startup of the machine, always stop the engine and remove the key from the ignition before leaving the operator's seat for any reason.



WARNING

- To avoid personal injury or death from explosion or fire, do NOT smoke or allow flame or sparks near fuel tank when refueling.
- NEVER refuel the windrower when the engine is hot or running.
- To avoid electric discharge and the risk of a fire or explosion, ensure that the fuel delivery system is properly bonded and grounded. A bonded fuel delivery system has an electrically conductive and unbroken connection between all components of the fuel delivery system (fuel supply tank, transfer pump, transfer hose, nozzle, and others). A wire connection from the fuel delivery system to the machine chassis will equalize the static electric potential between the two machines, further reducing the chance of a static electric discharge. A properly grounded fuel delivery system has an electrically conductive connection from the fuel delivery system tank to earth ground to allow static and electrical charge dissipation.

IMPORTANT:

Do NOT allow tank to empty. Running out of fuel can cause air locks and/or contamination of the fuel system. For instructions, refer to [Priming Fuel System, page 371](#).

1. Shut down the engine, and remove the key from the ignition.

OPERATION

2. Clean the area around the fuel filler cap (A).
3. Turn fuel filler cap (A) counterclockwise until loose. Remove cap.
4. Fill the tank with approved fuel. For fuel type and quantity, refer to the manual's inside back cover.

IMPORTANT:

Do **NOT** completely fill the tank as space is required for expansion. A filled tank could overflow if exposed to a rise in temperature, such as direct sunlight.

5. Replace fuel tank filler cap (A), and turn the cap clockwise until it clicks.

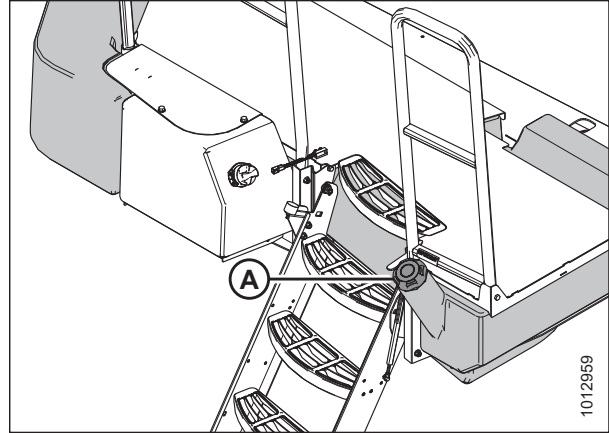

Figure 4.7: Fuel Tank Filler Cap

Filling the Diesel Exhaust Fluid Tank

The symbol inside the diesel exhaust fluid (DEF) gauge on the Harvest Performance Tracker (HPT) display will signal when DEF level is low.



WARNING

To avoid bodily injury or death from unexpected startup of the machine, always stop the engine and remove the key from the ignition before leaving the operator's seat for any reason.

1. Shut down the engine, and remove the key from the ignition.
2. Clean around filler cap (A).
3. Turn cap (A) counterclockwise until loose and then remove the cap.

NOTE:

The filler cap for the DEF tank is blue and the nozzle dispenser is smaller than that of the fuel tank.

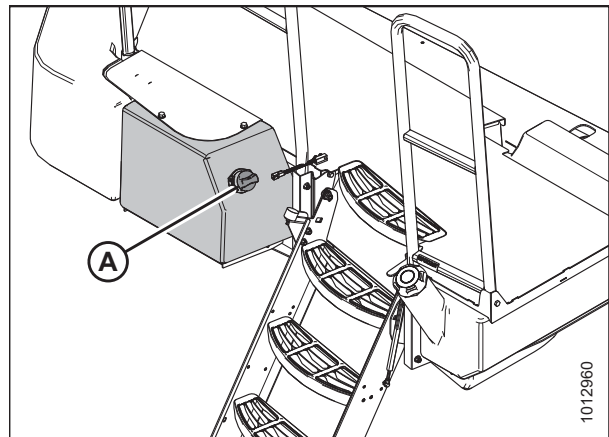

Figure 4.8: DEF Tank



CAUTION

Avoid contact with eyes. In case of contact, rinse immediately with water for 15 minutes.

4. Fill the tank with approved DEF. For specifications, refer to the inside back cover.

IMPORTANT:

DEF is corrosive. Spilled DEF must be contained and absorbed by non-combustible absorbent material like sand, and then shovelled into a suitable container for disposal. If spilled on the tank or any surface of the vehicle, rinse thoroughly with water.

OPERATION

IMPORTANT:

If the windrower temperature is going to be below 0°C (32°F), do **NOT** fill the DEF tank more than 75% full. When freezing, the DEF fluid will expand by approximately 7%. For storage information, refer to [5.1.1 Storing Lubricants and Fluids](#), page 293.

5. Replace filler cap (A) and turn clockwise until tight.

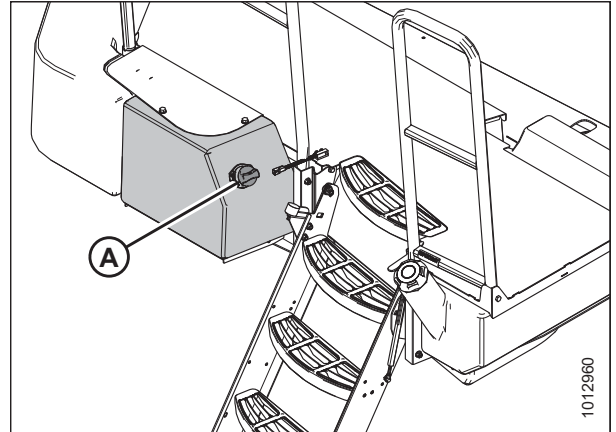

Figure 4.9: DEF Tank

Checking Engine Oil Level

Check the engine oil level frequently and watch for any signs of leakage.

WARNING

To avoid bodily injury or death from unexpected startup of the machine, always stop the engine and remove the key from the ignition before leaving the operator's seat for any reason.

NOTE:

During the break-in period, a higher than usual oil consumption should be considered normal.

NOTE:

Oil can be checked without opening the hood.

1. Operate the engine at low idle and check for leaks at the filter and drain plug.
2. Shut down the engine, and remove the key from the ignition.
3. Wait about 5 minutes.
4. Remove dipstick (A) by turning it counterclockwise to unlock.
5. Wipe the dipstick clean and reinsert it into engine.

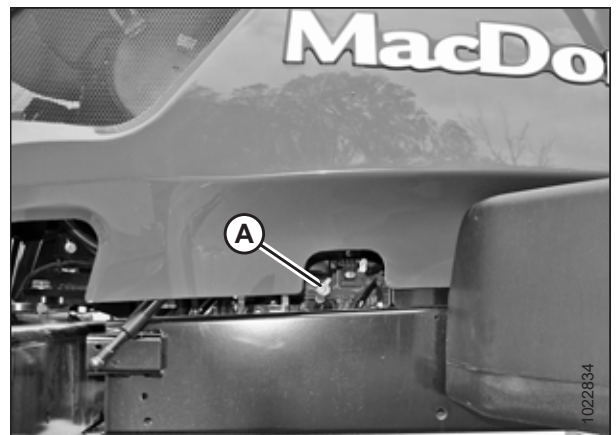

Figure 4.10: Dipstick Location

OPERATION

6. Remove the dipstick again and check the oil level. The oil level should be between LOW (L) and HIGH (H). If below the LOW mark, add oil.

NOTE:

Adding 1.9 liters (2 U.S. quarts) will raise the level from LOW to HIGH. To add oil, refer to [Adding Engine Oil, page 118](#).

7. Replace the dipstick and turn it clockwise to lock.

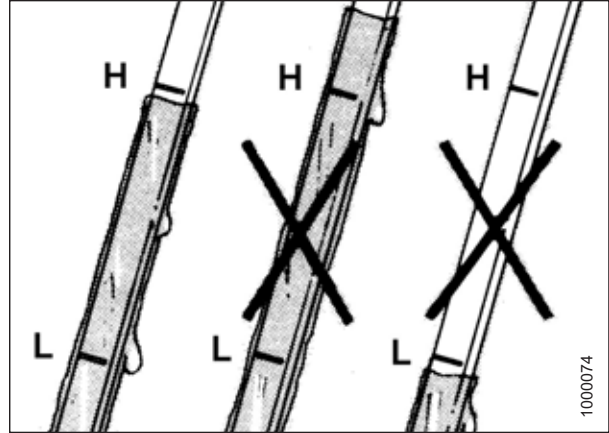

Figure 4.11: Engine Oil Level

Adding Engine Oil



WARNING

To avoid bodily injury or death from unexpected startup of the machine, always stop the engine and remove the key from the ignition before leaving the operator's seat for any reason.

1. Open the hood. For instructions, refer to [5.3.1 Opening Hood, page 302](#).
2. Clean around filler cap (A) and remove by turning it counterclockwise.
3. Carefully pour in of new oil. A funnel is recommended to avoid spillage. Refer to the inside back cover for oil specifications.



CAUTION

Do NOT fill above the HIGH mark.

4. Replace oil filler cap (A) and turn it clockwise until snug.

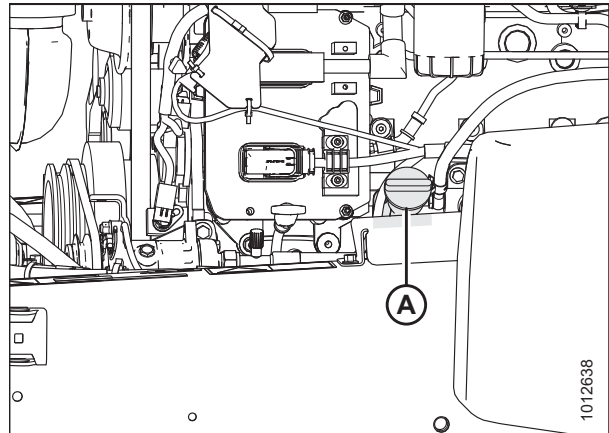

Figure 4.12: Oil Filler Cap

5. Check the oil level. For instructions, refer to [Checking Engine Oil Level, page 117](#).
6. Close the hood. For instructions, refer to [5.3.2 Closing Hood, page 303](#).

4.3.5 Engine Operation

Starting the Engine



DANGER

- Before starting the engine, be sure there is plenty of ventilation to avoid asphyxiation.
- Avoid possible injury or death from a runaway machine.
- This machine has safety devices which allow the engine to start only when the ground speed lever (GSL) is in PARK, the steering wheel is locked in the PARK position, and the HEADER ENGAGE switch is in the OFF position. Under NO circumstances are these devices to be deliberately rewired or misadjusted so that the engine can be started with controls out of NEUTRAL.
- Do NOT start the engine by shorting across the starter or starter relay terminals. If normal starting circuitry is bypassed, the machine will start with the drive engaged and move.
- Start the engine only from operator's seat with controls in PARK. NEVER start the engine while standing on ground. NEVER try to start the engine with someone under or near the machine.

IMPORTANT:

Before starting the windrower, check fluid level of the following, and add fluid if necessary:

- Engine oil – refer to [Checking Engine Oil Level, page 117](#)
- Hydraulic oil – refer to [5.7.3 Checking Hydraulic Oil, page 337](#)
- Gearbox oil – refer to [5.7.7 Checking Engine Gearbox Lubricant Level and Adding Lubricant, page 343](#)

IMPORTANT:

Do NOT tow the machine to start the engine. Damage to hydrostatic drives will result.

NOTE:

When the console receives a wake-up signal, the console awakens from sleep mode and closes the battery disconnect relay. The Harvest Performance Tracker (HPT) goes into a boot-up sequence that takes approximately 40 seconds. The following items trigger a wake-up signal for the console:

- Key switch ignition or accessory positions
- Cab door switch
- Horn button
- Hazards button
- Field lights button
- Clearance lights button
- Road lights button
- High beam button

OPERATION

1. Before starting the engine, ensure engine exhaust pipe (A) is not covered or obstructed.

NOTE:

Before taking the GSL out of PARK, let the hydraulic oil warm up to 32°C (90°F). You can view the hydraulic oil temperature on Run Screen 4 on the Harvest Performance Tracker (HPT) display. For instructions, refer to [Viewing Engine Cooling Data, page 128](#).



Figure 4.13: Engine Exhaust

2. Ensure the cab-forward or engine-forward directional lock (A) is engaged at the base of the steering column.

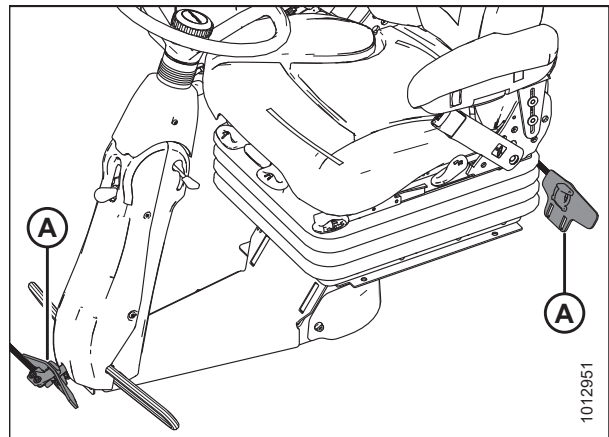

Figure 4.14: Direction Locks

3. Move GSL (A) into PARK (C).
4. Turn the steering wheel until it locks. It may be possible to move the steering wheel slightly in the locked position.

IMPORTANT:

Do **NOT** attempt to force the wheel out of the locked position or damage to the steering system may occur.

5. Fasten the seat belt.
6. Push HEADER ENGAGE switch (B) to ensure it is in the OFF position.

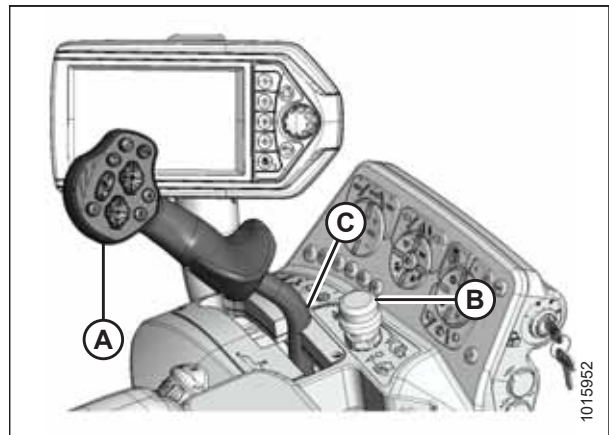

Figure 4.15: Operator Controls

OPERATION

7. Turn IGNITION switch (A) to the ON position; the Harvest Performance Tracker (HPT) display (B) will illuminate. If the HPT is still booting up, wait for WAIT TO START (WTS) symbol (C) to disappear before trying to start engine.
8. Check that red PARK symbol light (D) is ON and that there are no error messages on screen.
9. Press HORN button (E) three times prior to starting the engine.

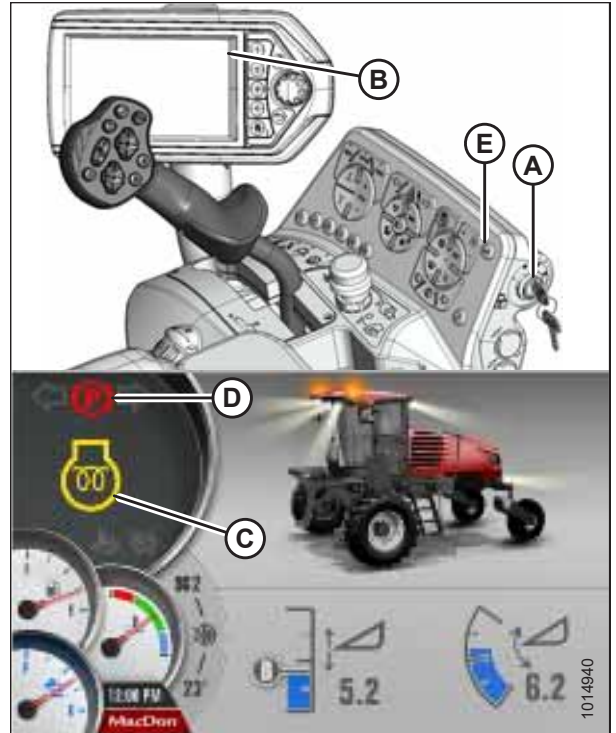

Figure 4.16: Console and HPT Run Screen

10. Turn the IGNITION switch to crank (A).

NOTE:

When the engine starts and the header is not engaged, the HPT will display the header disengaged page (B).

IMPORTANT:

- Do **NOT** operate the starter for longer than 15 seconds at a time.
- If the engine does not start, wait at least 2 minutes before trying again.
- If you crank the engine for more than 30 seconds within a 2-minute period, the engine will lock the starter circuit to prevent overheating, and a flashing WTS symbol will appear on the display. Wait for the WTS symbol to stop flashing before attempting to crank engine again.
- If the engine still does not start, refer to [Engine Start Troubleshooting Tips, page 123](#).

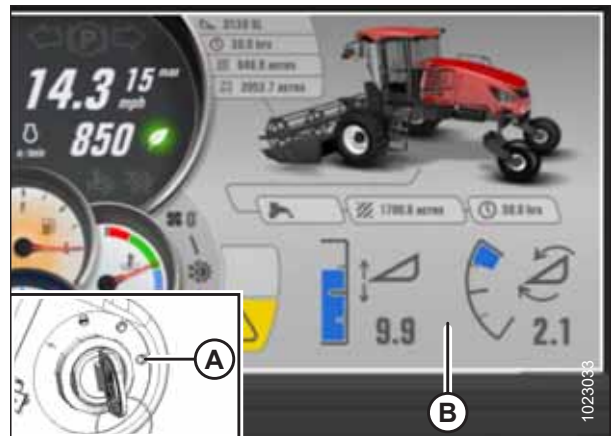

Figure 4.17: HPT Header Disengaged Screen

OPERATION

NOTE:

When the engine temperature is below 5°C (40°F), the engine will cycle through a period where it appears to labor until it warms up. Do **NOT** operate the engine above 1500 rpm until the HPT engine temperature gauge is above the blue range (A).



Figure 4.18: HPT No Header Screen

OPERATION

Engine Start Troubleshooting Tips

If the windrower will not start normally, refer to the following troubleshooting table:

IMPORTANT:

Do **NOT** tow the machine to start engine. Damage to the hydrostatic drives will result.

Table 4.1 Engine Start Troubleshooting

Problem	Solution
Controls not in NEUTRAL	<ul style="list-style-type: none"> • Move GSL to NEUTRAL • Move steering wheel to locked (centered) position • Disengage HEADER switch
Operator's station not locked	<ul style="list-style-type: none"> • Adjust position of operator's station • Ensure lock is engaged
Neutral interlock misadjusted	<ul style="list-style-type: none"> • Contact MacDon Dealer
No fuel to engine	<ul style="list-style-type: none"> • Fill empty fuel tank • Replace clogged filter • Check for blocked or damaged fuel lines
Old fuel in tank	<ul style="list-style-type: none"> • Drain tank • Refill with fresh fuel
Water, dirt, or air in fuel system	<ul style="list-style-type: none"> • Drain, flush, fill, and prime system
Improper type of fuel	<ul style="list-style-type: none"> • Drain tank • Refill with correct fuel
Crankcase oil too heavy	<ul style="list-style-type: none"> • Replace with recommended oil
Low battery output	<ul style="list-style-type: none"> • Test the battery • Check battery electrolyte level
Poor battery connection	<ul style="list-style-type: none"> • Clean and tighten loose connections
Faulty starter	<ul style="list-style-type: none"> • Contact MacDon Dealer
Wiring shorted, circuit breaker open	<ul style="list-style-type: none"> • Check continuity of wiring and breaker (manually reset)
Faulty injectors	<ul style="list-style-type: none"> • Contact MacDon Dealer

OPERATION

Programming the Eco Engine Control

Engine speed can be programmed to operate at reduced rpm to lower fuel and diesel exhaust fluid (DEF) consumption, and to reduce in-cab noise levels. The set-point for engine speed can be adjusted in increments of 100 rpm from 1800 to 2300 rpm in the Harvest Performance Tracker (HPT) QuickMenu. While the header is engaged, the system can easily be activated and deactivated (depending on field conditions) using the Eco Engine Control (EEC) button (A) on the console. When the engine is running at less than full speed, you will notice a small reduction in the maximum reel, draper, and ground speeds.

The EEC feature is turned ON or OFF by pressing the EEC button (A) on the operator's console. EEC will only be available when the header is engaged. The GREEN LEAF symbol on the HPT display indicates that the EEC is active. If EEC is turned OFF, or the header is disengaged, the LEAF symbol will appear grayed out. The EEC throttle limit can be adjusted at any time.

1. To open the QuickMenu system while in any run screen, press the scroll knob (A) on the HPT.

2. Use the HPT scroll knob to move the red cursor to the ECO THROTTLE LIMIT (A) value.
3. Press the HPT scroll knob to select the ECO THROTTLE LIMIT (A) adjustment function.
4. Adjust the ENGINE rpm value using the HPT scroll knob.
5. Press the HPT scroll knob to program the adjusted value.

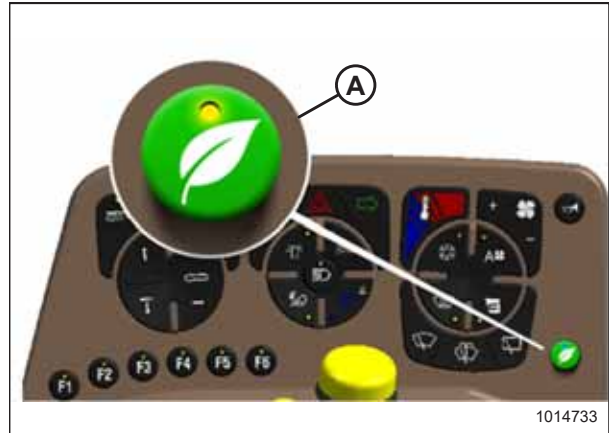

Figure 4.19: Eco Engine Control (EEC) Button



Figure 4.20: HPT Scroll Knob/Select Button



Figure 4.21: HPT Display

Shutting down the Engine

CAUTION

Park on a flat, level surface with the header on the ground, the ground speed lever (GSL) in PARK position, and the steering wheel in locked position (centered). Wait for the HPT to beep and display a red P symbol to confirm the park brakes have engaged.

IMPORTANT:

Before stopping the engine, run at low idle for approximately 5 minutes to cool hot engine parts (and allow turbocharger to slow down while engine oil pressure is available).

1. Park the windrower on a level surface.
2. Lower the header.
3. Place ground speed lever (GSL) (B) into PARK.
4. Lock the steering wheel.
5. Turn ignition key (A) counterclockwise to the OFF position.

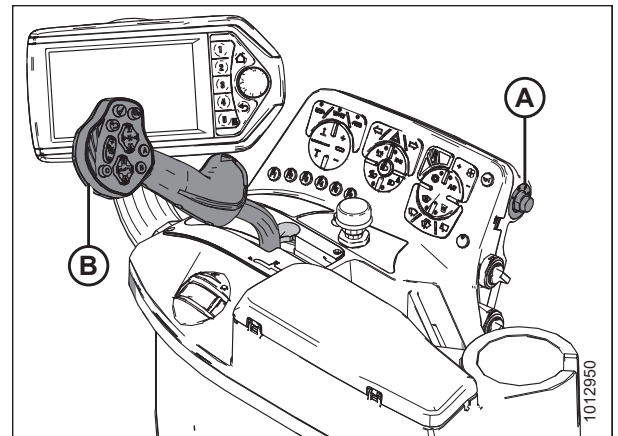

Figure 4.22: Console

Engine Temperature

The engine temperature gauge (A) is displayed in the lower left corner of the Harvest Performance Tracker (HPT) display.

Normal engine operating temperature is indicated when the needle is in the green range of the gauge.

If the engine temperature exceeds 105°C (221°F), the needle will move to the red range of the gauge. Depending on the temperature, the engine will trigger a fault code and an amber caution or red stop light will illuminate on the HPT display.

When the engine temperature is below 5°C (40°F), the engine will cycle through a period where it appears to labor until the engine warms up. Do **NOT** operate engine above 1500 rpm until the HPT engine temperature gauge is above the blue range.

NOTE:

Before taking the ground speed lever (GSL) out of PARK, let the hydraulic oil warm up to 32°C (90°F). You can view the hydraulic oil temperature on Run Screen 4 on the Harvest Performance Tracker (HPT) display. For instructions, refer to [Viewing Engine Cooling Data, page 128](#).



Figure 4.23: HPT Display – Engine Temperature Gauge

OPERATION

Engine Oil Pressure

The nominal engine oil pressure is 69 kPa (10 psi) at low idle and 380 kPa (55.1 psi) at maximum rated speed.

If the oil pressure drops below the preset level of 52 kPa (7.5 psi), the Harvest Performance Tracker (HPT) displays an engine telltale fault code to identify the issue.

If the red STOP ENGINE light illuminates, stop the engine **IMMEDIATELY** and investigate.

If the amber CAUTION light illuminates, stopping immediately is optional. You may continue operations and investigate later, but you are **STRONGLY** advised to monitor the situation carefully.

Exhaust System Cleaning

The exhaust aftertreatment system uses diesel exhaust fluid (DEF) and selective catalyst reduction (SCR) technology to reduce the emission of nitrogen oxides (NOx). The process involves injecting DEF (a nitrogenous compound which decomposes into ammonia) into the exhaust over a catalyst. The ammonia reacts with NOx, producing harmless nitrogen and water.

Automatic exhaust system cleaning events maintain the performance of the aftertreatment system by increasing exhaust temperatures in order to remove the buildup of crystallized DEF. Automatic cleaning occurs any time during machine operation as long as the INHIBIT SCR CONDITIONING switch is OFF. Turn on the INHIBIT SCR CONDITIONING switch if the environment is not suitable for high exhaust temperatures (e.g., inside a building). The INHIBIT SCR CONDITIONING switch is intended as a temporary measure. If the INHIBIT switch is left on for an extended period, the engine will derate until manual SCR conditioning is performed.

Activate the MANUAL SCR CONDITIONING exhaust system cleaning if the automatic exhaust system cleaning was deactivated during normal operation. Engine speed may vary between 1000 and 1400 rpm during manual exhaust system cleaning.

OPERATION

Activating the Exhaust Aftertreatment Functions

Follow these steps to access the exhaust aftertreatment functions on the Harvest Performance Tracker (HPT) display.

1. To display the main menu, press the soft key 5 / menu button (A) on the HPT.
2. To display the manual / inhibit SCR conditioning switches, press soft key 5 / menu button (A) next to the EXHAUST AFTERTREATMENT icon (B).

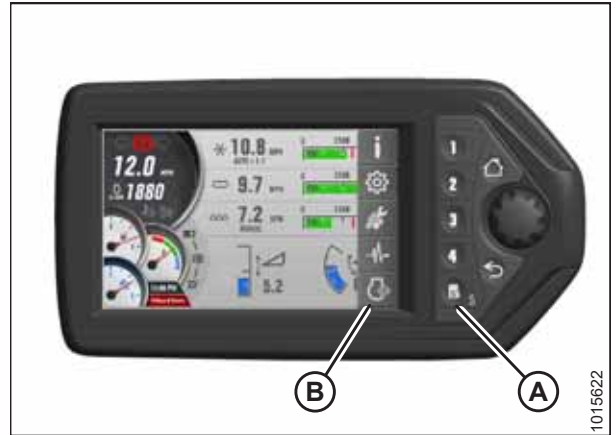

Figure 4.24: HPT Display

3. To inhibit SCR conditioning, press soft key 5 / menu button (A) next to the INHIBIT SCR CONDITIONING icon (B), and hold for 3 seconds. The SCR CONDITIONING INHIBIT icon (C) will appear under the engine rpm display.



Figure 4.25: HPT Display

4. To select manual SCR conditioning, press soft key 4 (A) next to MANUAL SCR CONDITIONING icon (B), and hold for 3 seconds. High exhaust system temperature (HEST) icon (C) appears highlighted under the rpm display during system cleaning.

NOTE:

The HEST icon also appears during normal operation when exhaust temperature exceeds the maximum temperature threshold. The icon remains on until the exhaust temperature drops below the minimum temperature threshold.



Figure 4.26: HPT Display

OPERATION

Viewing Engine Cooling Data

You can check current engine cooling information on Run Screen 4 on the Harvest Performance Tracker (HPT) display.



Figure 4.27: Run Screen 4 – Cooling Data

A - Fan Speed

B - Hydraulic Oil Temperature

C - Engine Air Intake Temperature

D - Engine Coolant Temperature

E - Header Height

F - Header Tilt

To display the windrower's cooling data:

1. Press soft key 4 (A) on the Harvest Performance Tracker (HPT) to open the COOLING DATA display.

NOTE:

Soft keys 1–5 also function as buttons within menus.

NOTE:

The engine fan speed will increase/decrease, depending on cooling requirements. A small fan icon will appear beside the icon of the parameter that is currently controlling the fan.

NOTE:

The engine fan will automatically reverse on a set time interval, or when one of the system temperatures gets high enough. No operator input is required to reverse the fan.

You can view

- Fan speed
- Engine air intake temperature
- Engine coolant temperature



Figure 4.28: HPT Display

4.3.6 Operating the Windrower

Entering and Exiting the Windrower

CAUTION

To prevent slipping and possible injury, ALWAYS face the windrower and use the hand rail when dismounting (or mounting). NEVER attempt to get on or off a moving windrower. Before leaving the operator's seat for any reason:

- Park on a flat, level surface with the ground speed lever in PARK position and the steering wheel in locked position (centered). Wait for the HPT to beep and display a red P symbol to confirm the park brakes have engaged.
- Fully lower the header and reel.
- Disengage the header drives.
- To avoid bodily injury or death from unexpected startup of machine, always stop engine and remove key from ignition.
- Turn off the lights unless required for inspection purposes.
- Release the seat belt.
- Turn off the wipers.
- Raise the armrest and steering wheel for easier exit and re-entry.
- Lock the cab door when leaving the windrower unattended. (When the door is locked, it can still be opened from inside the cab.)

A swing-away platform with stairs (A) is provided on the left side of the windrower to accommodate cab-forward and engine-forward access to the operator's station as well as several maintenance tasks.

Two doors (B) are provided for cab entry and exit in either cab-forward mode or engine-forward mode. Enter the cab using the door opposite the operator's console.

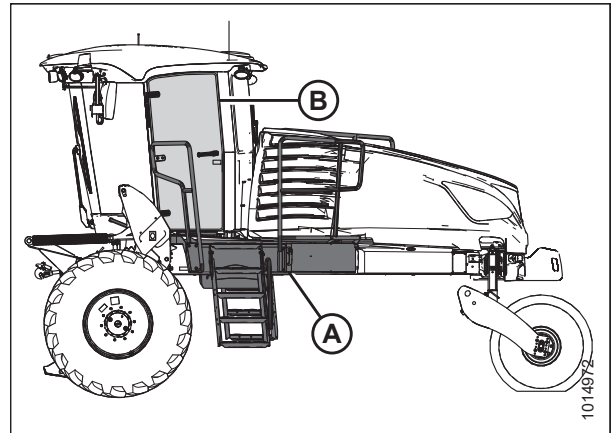

Figure 4.29: Platforms and Doors

OPERATION

Adjusting Ground Speed Limit

The windrower has the following selectable ground speed limits depending on seat position:

Table 4.2 Selectable Ground Speed Limits

Direction of Travel	Selectable Ground Speed Limits
Cab-forward (Standard drive wheel)	16, 19, 23, 29 km/h (10, 12, 14, 16, 18 mph)
Engine-forward (Standard drive wheel)	16, 29, 43 km/h (10, 18, 27 mph)
Cab-forward (High torque drive wheel)	13, 19, 23, 29 km/h (8, 12, 14, 16, 18 mph)
Engine-forward (High torque drive wheel)	16, 34.6 km/h (10, 21.5 mph)

To adjust the ground speed limit, follow these steps:

1. Press scroll knob (A) on the Harvest Performance Tracker (HPT) while in any run screen to open the QuickMenu system.



Figure 4.30: HPT Scroll Knob / Select Button

2. To scroll to the GROUND SPEED LIMIT selectable area (A), use the HPT scroll knob to move the red cursor.
3. Press the HPT scroll knob to select, and scroll to adjust the ground speed limit values.

NOTE:

Ground speed limit is also changed by simultaneously pressing the GSL shift button on back of GSL and scrolling.



Figure 4.31: HPT Display

Driving Forward in Cab-Forward Mode

In cab-forward mode, the operator's station is facing away from the engine.

WARNING

Do NOT drive windrower on road in cab-forward configuration unless it is equipped with the proper lighting and markings for cab-forward road travel.

WARNING

Outside of North America, do NOT drive windrower on the road in cab-forward mode, as lighting/reflector visibility will not be compliant with road regulations.



Figure 4.32: Cab-Forward Mode

CAUTION

Operate both steering wheel and ground speed lever slowly for familiarization. Avoid the common tendency of new Operators to oversteer.

CAUTION

Park on a flat, level surface with the ground speed lever (GSL) in PARK position and the steering wheel in locked position (centered). Wait for the HPT to beep and display a red P symbol to confirm the park brakes have engaged.

1. Park the windrower on a level surface.
2. If the operator's seat is in the cab-forward position (facing away from the engine), skip to Step 3, page 131.

If the operator's seat is facing the engine, swivel the operator's seat to the cab-forward position as follows:

- a. Place ground speed lever (GSL) (A) in PARK. The engine can be running.

IMPORTANT:

If the GSL is **NOT** in PARK, swivelling the operator's station may damage the GSL cable.

- b. Pull up on knob (B) and hold to release latch (C) at the base of the steering column.
- c. Turn the steering wheel counterclockwise to pivot the operator's station clockwise 180° until the pin engages the latch to secure the operator's station in the new position.

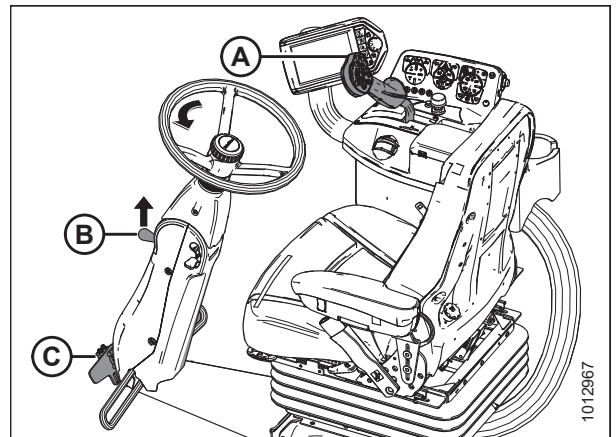

Figure 4.33: Operator Station

3. Ensure the seat belt is fastened.
4. Start the engine (if not already running). For instructions, refer to *Starting the Engine, page 119*.
5. Set the desired ground speed limit. For instructions, refer to *Adjusting Ground Speed Limit, page 130*.

WARNING

Check to be sure all bystanders have cleared the area.

6. Slowly push throttle (A) to full forward (operating speed).
7. Move GSL (B) out of PARK and slowly forward to desired speed.

NOTE:

The transmission is most efficient with the engine at full speed and the GSL fully forward. The windrower can be equipped with an automatic steering system for use in the field. An automated steering system is available as an option and can be installed by a MacDon Dealer. The GSL has been pre-wired at the factory with a switch. For more information, refer to [6.1.1 Automated Steering Systems](#), page 439.

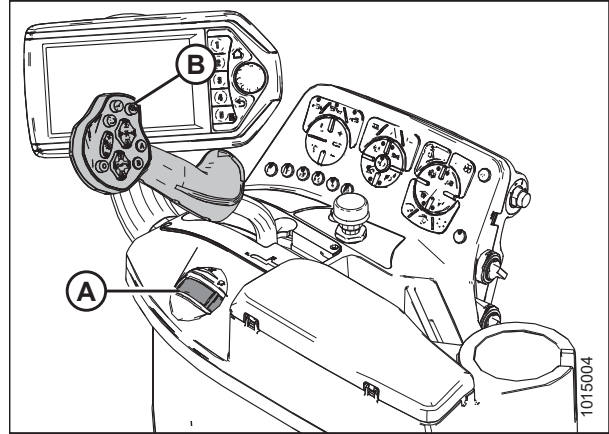

Figure 4.34: Console

Driving in Reverse in Cab-Forward Mode

WARNING

Back up slowly. Steering is opposite to normal when reversing. Hold the steering wheel at the bottom and turn the wheel in the direction you want the rear of the machine to travel.

1. Move throttle lever (A) to a mid-range position.

NOTE:

Reversing in low speed range and at reduced engine speed is recommended since steering will be less sensitive than at higher speed settings.

WARNING

Check to be sure all bystanders have cleared the area.

2. Move ground speed lever (GSL) (B) rearward to the desired speed.

3. Steer as shown.

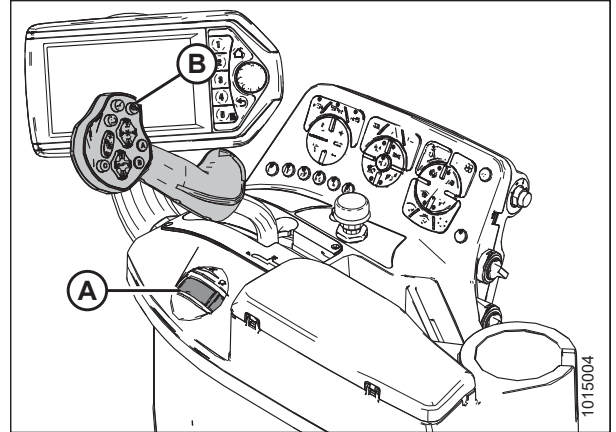

Figure 4.35: Console

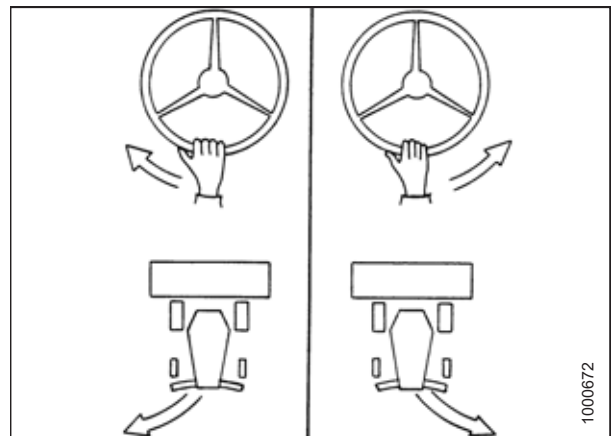

Figure 4.36: Cab-Forward Mode

OPERATION

Driving Forward in Engine-Forward Mode

In the engine-forward mode, the operator's station is facing toward the engine.

If necessary, swivel the operator's station to engine-forward position as follows:



Figure 4.37: Engine-Forward – Seat Faces Engine

CAUTION

Park on a flat, level surface with the ground speed lever (GSL) in PARK position and the steering wheel in locked position (centered). Wait for the HPT to beep and display a red P symbol to confirm the park brakes have engaged.

1. Park the windrower on a level surface.
2. If the operator's seat is facing the engine, skip to Step 3, [page 134](#).

If the operator's seat is in the cab-forward position, swivel the operator's seat to the engine-forward position as follows:

- a. Place ground speed lever (GSL) (A) in PARK. The engine can be running.

IMPORTANT:

If the GSL is **NOT** in PARK, swivelling the operator's station may damage the GSL cable.

- b. Pull up on knob (B) and hold to release latch (C) at the base of the steering column.
 - c. Turn the steering wheel counterclockwise to pivot the operator's station clockwise 180° until the pin engages the latch to secure the operator's station in the new position.
3. Ensure the seat belt is fastened.
 4. Start the engine (if not already running). For instructions, refer to [Starting the Engine, page 119](#).
 5. Use the Harvest Performance Tracker (HPT) to adjust the maximum speed setting to 43 km/h (27 mph). For instructions, refer to [Adjusting Ground Speed Limit, page 130](#).

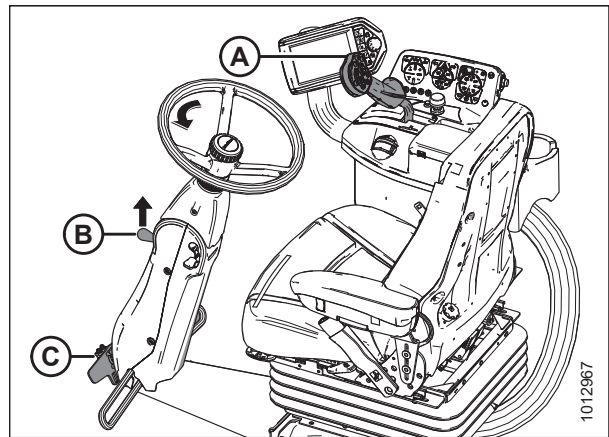

Figure 4.38: Operator Station

OPERATION

- Slowly push throttle (A) to full forward (operating speed).

WARNING

Check to be sure all bystanders have cleared the area.

- Slowly move GSL (B) forward to the desired speed.

NOTE:

The transmission is most efficient with the engine at full speed and the GSL fully forward.

CAUTION

Operate both steering wheel and ground speed lever slowly while becoming familiar with the machine. Steering can be sensitive; avoid the tendency of new Operators to overcorrect.

- If more tractive (lugging) power is required (e.g., when driving up a ramp, up a hill, or out of a ditch):
 - Move GSL (A) closer to NEUTRAL.
 - Reduce max speed setting to 16 km/h (10 mph) by holding the shift button on the GSL while scrolling downwards, or by reducing the max speed setting using the QuickMenu. For instructions, refer to [Adjusting Ground Speed Limit, page 130](#).
- Once the lugging condition no longer exists:
 - Set GSL (A) to **NOT MORE THAN HALF** maximum forward speed.
 - For standard drive wheel: Adjust the maximum speed setting back to 43 km/h (27 mph). For instructions, refer to [Adjusting Ground Speed Limit, page 130](#).

For high torque drive wheel: Adjust the maximum speed setting back to 34.6 km/h (21.5 mph). For instructions, refer to [Adjusting Ground Speed Limit, page 130](#)

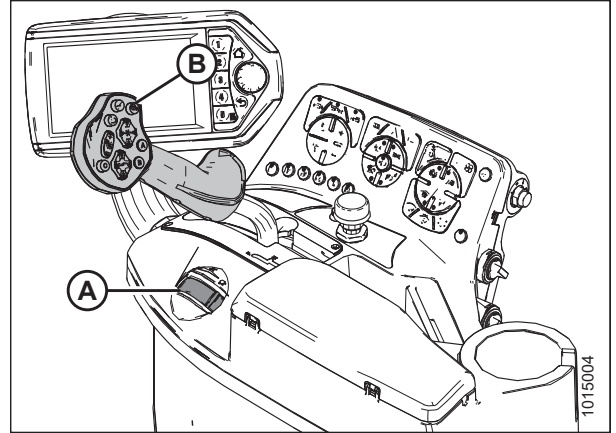

Figure 4.39: Console

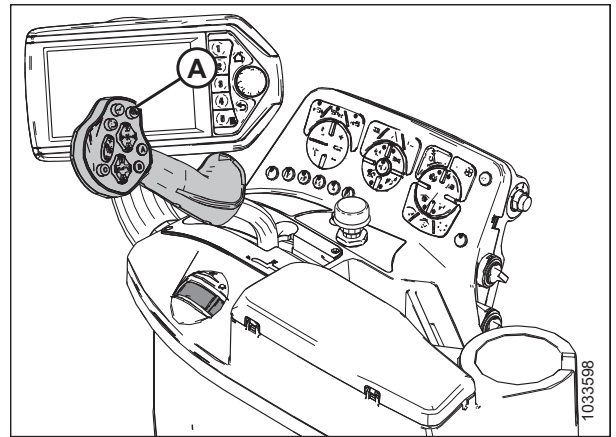

Figure 4.40: Console

OPERATION

Driving in Reverse in Engine-Forward Mode

WARNING

Back up slowly. Steering is opposite to normal when reversing. Hold the steering wheel at the bottom and turn the wheel in the direction you want the rear of the machine to travel.

1. Move throttle lever (A) to a mid-range position.

NOTE:

Reversing in low speed range and at reduced engine speed is recommended since steering will be less sensitive than at higher speed settings.

2. Move ground speed lever (GSL) (B) rearward to desired speed.

WARNING

Check to be sure all bystanders have cleared the area.

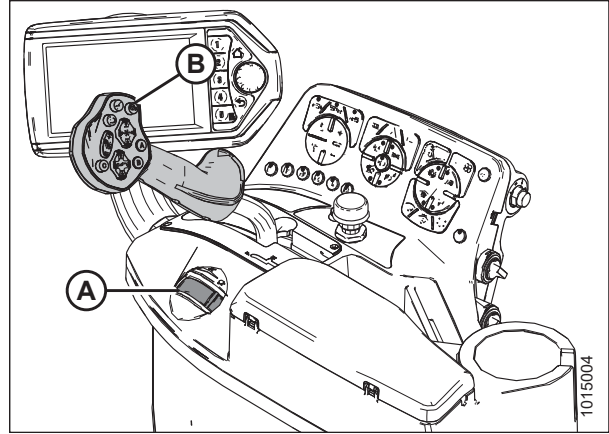

Figure 4.41: Console

3. Steer as shown.

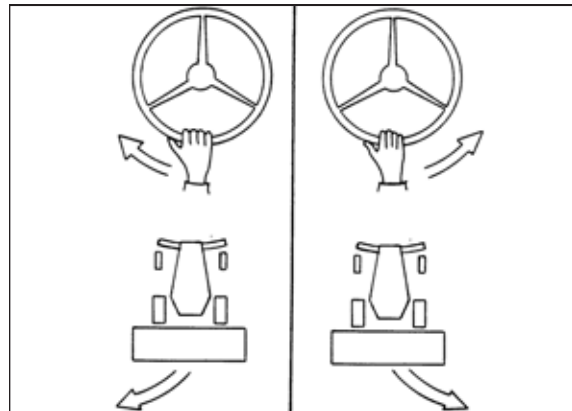

Figure 4.42: Steering the Windrower

Spin Turning

Hydrostatic steering provides significantly more maneuverability than mechanical steering.

CAUTION

Be sure the area is clear before making turns. Although the windrower pivots on the spot, the ends of the header travel faster and in a large arc.

1. Move ground speed lever (GSL) (A) out of PARK towards the seat and hold.
2. Slowly turn the steering wheel in the desired direction of turn. The windrower will pivot between the drive wheels.
3. To increase the turn radius, slowly move the GSL away from NEUTRAL. Remember that this will increase ground speed as well.
4. To stop the turn, slowly turn the steering wheel back to its centered position.

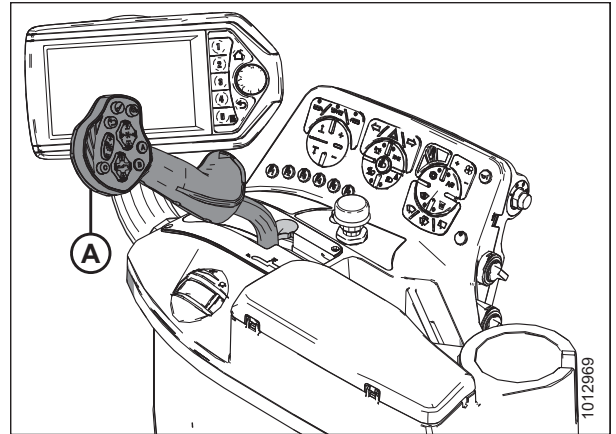

Figure 4.43: Console

Stopping

WARNING

Do NOT move the ground speed lever (GSL) rapidly back to NEUTRAL. You may be thrown forward by a sudden stop and the wheels may skid, reducing steering control. Always wear a seat belt when operating the windrower.

CAUTION

Park on a flat, level surface with the ground speed lever (GSL) in PARK position and the steering wheel in locked position (centered). Wait for the HPT to beep and display a red P symbol to confirm the park brakes have engaged.

1. Anticipate stopping and **SLOWLY** return the ground speed lever (GSL) (A) to NEUTRAL and into PARK.
2. Turn the steering wheel until it locks.
3. Move throttle lever (B) to low-idle position.

IMPORTANT:

Before stopping the engine, run at low idle for approximately 5 minutes to cool hot engine parts and allow the turbocharger to slow down while engine oil pressure is available.

NOTE:

Avoid unnecessary idling. Stop the engine if it will be idling for longer than 5 minutes.

NOTE:

Brakes are automatically engaged when steering wheel is locked in PARK position.

4. Turn the ignition key counterclockwise to OFF position.

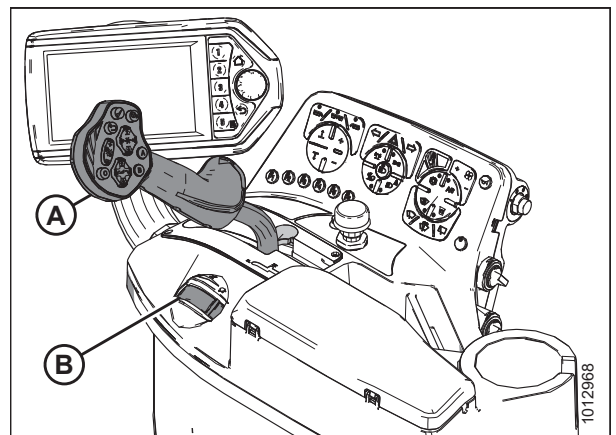

Figure 4.44: Console

OPERATION

Viewing Performance Data

You can check current performance information on Run Screen 3 on the Harvest Performance Tracker (HPT) display.

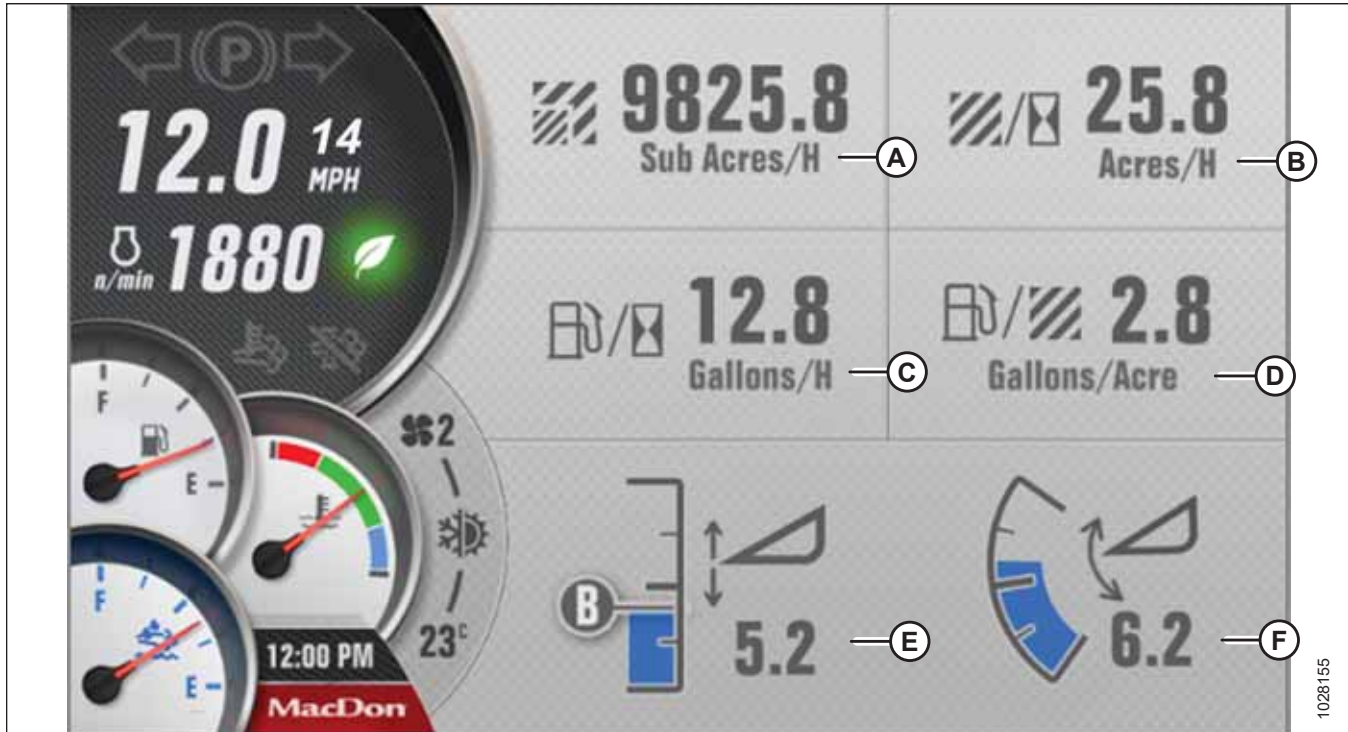

Figure 4.45: Run Screen 3 – Performance Data

A - Sub Acres

B - Acres per Hour

C - Fuel Used per Hour

D - Fuel Used per Acre

E - Header Height

F - Header Tilt

To display the windrower's performance data:

1. Press soft key 3 (A) on the Harvest Performance Tracker (HPT) to open the PERFORMANCE DATA display.

NOTE:

Soft keys 1–5 also function as buttons within menus.

NOTE:

The sub acres can also be reset from this screen. Press the HPT scroll knob to highlight and select the sub acres. If you press the HPT scroll knob a second time, the message RESET OR EXIT appears on the display. Select RESET to reset the sub acres to zero and return to the same highlighted sub acres. Select EXIT or press the BACK or HOME button to dismiss the message without resetting the sub acres.

You can view:

- Sub acres (A)
- Acres per hour (B)
- Fuel used per hour (C)
- Fuel used per acre (D)



Figure 4.46: HPT Display

4.3.7 Transporting

Driving on Road in Engine-Forward Mode

The M1240 Windrower is designed to be driven on the road with the engine facing forward to provide better visibility for the Operator and improved stability for the machine.

Windrowers sold in North America can also be driven on roads in cab-forward mode, with or without a header attached, but at a reduced speed, under restricted conditions. For instructions, refer to [Driving on Road in Cab-Forward Mode, page 142](#).

CAUTION

Windrowers sold outside of North America: Do NOT drive windrower on the road in cab-forward mode, as lighting and marking will not be compliant with road regulations.

WARNING

A collision between the windrower and other vehicles may result in injury or death.

WARNING

When driving the windrower on public roadways:

- Obey all highway traffic regulations in your area. Use pilot vehicles in front and rear of the windrower if required by law.
- Use a slow-moving vehicle emblem and flashing warning lights unless prohibited by law.
- If the width of the attached header impedes other vehicle traffic, remove the header and install a MacDon-approved weight box.

WARNING

Do NOT drive the windrower on a road or highway at night or in conditions that reduce visibility, such as fog or rain. The width of the windrower may not be apparent under these conditions.

CAUTION

Check local laws for width regulations and lighting and marking requirements before transporting on roads.

Before driving windrower on a roadway:

1. Ensure header engage switch (A) is off (down position).
2. Clean the flashing amber lights, red tail lights, and head lights, and ensure they are working properly.
3. Clean all reflective surfaces and slow moving vehicle signs.
4. Adjust the interior rear view mirror and clean windows.
5. Ensure the header (if attached) is fully raised and the header lift safety props are engaged.
6. If the width of the attached header impedes other vehicle traffic, remove the header and install a MacDon approved weight box. For instructions, refer to [Preparing Windrower to Tow a Header, page 146](#).

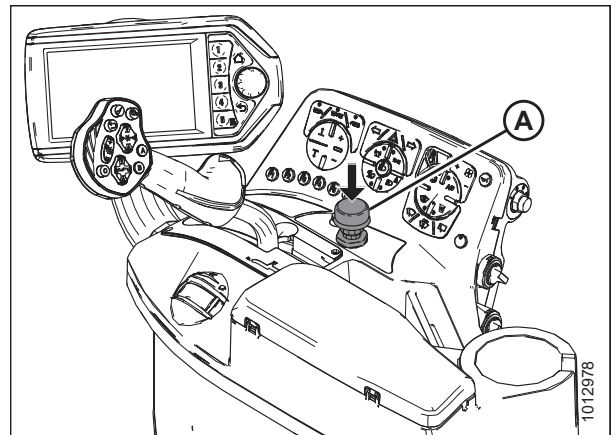

Figure 4.47: Header Engage Switch

OPERATION

7. If towing a header, refer to *Towing Header with Windrower, page 145*.

8. Press switch (A) for road lights. Always use these lights when driving windrower on roads.

9. Press switch (B) for high/low beams as required when other vehicles are approaching.

IMPORTANT:

Do **NOT** use field lights on the road; other drivers may be confused by them.

10. Press switch (C) to activate the beacons.

11. Press switch (D) to activate the hazard lights.

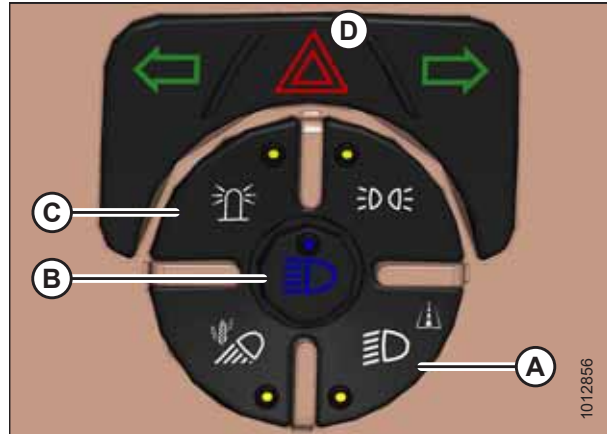

Figure 4.48: Light Switches

12. Set the desired maximum ground speed limit. For instructions, refer to *Adjusting Ground Speed Limit, page 130*.

NOTE:

Maximum ground speed can be set while the windrower is moving. Anticipate acceleration or deceleration if changing maximum speed while moving.

13. Slowly push throttle (A) to full forward (operating speed).

WARNING

Check to be sure all bystanders have cleared the area.

15. Move GSL (B) out of PARK and slowly forward to desired speed.

16. If towing a header, refer to *Towing Header with Windrower, page 145*.

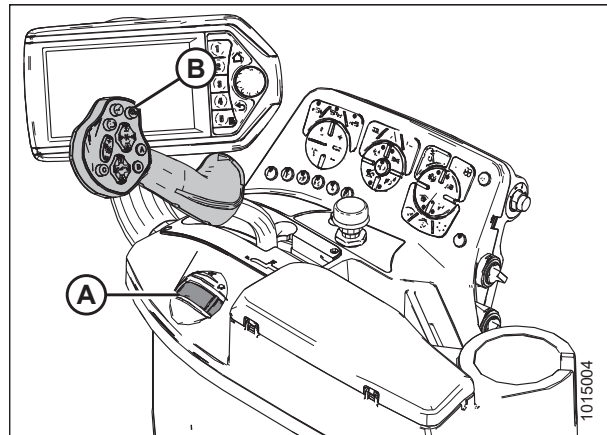

Figure 4.49: Console



Figure 4.50: Towing a Header

 **WARNING**

To avoid serious injury or death from loss of control:

- Do NOT make abrupt changes in steering direction.
- Anticipate turns and steep slopes by slowing down well in advance. Before making an abrupt turn, pull back on the ground speed lever (GSL) as steering is more responsive at reduced speeds.
- Do NOT rapidly accelerate or decelerate while turning.

When traveling on steep slopes:

- Move the GSL closer to NEUTRAL to reduce speed.
- Lower the header.
- If the ground speed is greater than or equal to 51 km/h (30 mph), the HPT will display a warning message (SLOW DOWN) with an audible alert. Move GSL closer to NEUTRAL to reduce speed.

With the header removed, steering control is reduced if weight is not added to drive wheels. If you must drive the windrower without header or MacDon weight system:

- Do NOT exceed the minimum speed setting.
- Avoid loose gravel and slopes.
- Do NOT tow a header.
- If control of machine is lost, immediately pull the GSL to NEUTRAL.

OPERATION

Driving on Road in Cab-Forward Mode

The M1240 Windrower is capable of being driven on the road in cab-forward mode, with or without a header attached, but at a reduced speed, under restricted conditions, and only for models sold in North America.

WARNING

Windrowers sold outside of North America: Do NOT drive windrower on the road in cab-forward mode, as lighting/reflector visibility will not be compliant with road regulations.

WARNING

A collision between the windrower and other vehicles may result in injury or death.

WARNING

When driving the windrower on public roadways:

- Obey all highway traffic regulations in your area. Use pilot vehicles in front and rear of the windrower if required by law.
- Use a slow-moving vehicle emblem and flashing warning lights unless prohibited by law.
- If the width of the attached header impedes other vehicle traffic, remove the header and install a MacDon-approved weight box.

WARNING

Do NOT drive the windrower on a road or highway at night or in conditions that reduce visibility, such as fog or rain. The width of the windrower may not be apparent under these conditions.

CAUTION

Check local laws for width regulations and lighting and marking requirements before transporting on roads.

Before driving the windrower on a roadway:

1. Clean the flashing amber lights, red tail lights, and head lights, and check that they work properly.
2. Clean all reflective surfaces and slow moving vehicle emblems.
3. Adjust the interior rear view mirror and clean windows.
4. Ensure header engage switch (A) is off (down position).

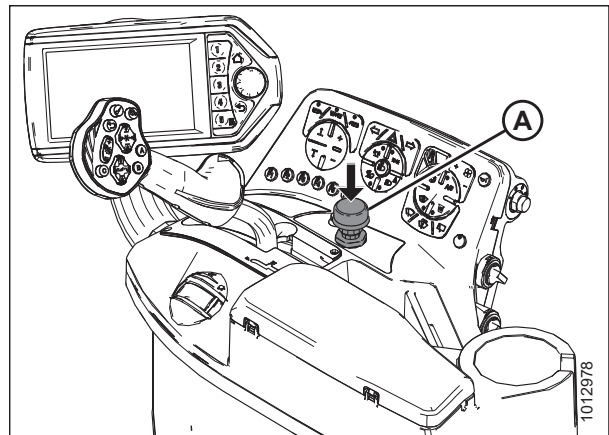

Figure 4.51: Header Engage Switch

OPERATION

CAUTION

Do **NOT** raise the header too high. Make sure you have good visibility out of the cab and that motorists are able to see the header lights.

5. Raise the header (if attached) enough to clear common obstacles, and then engage the header lift safety props.
6. If the width of attached header impedes other vehicle traffic, remove header and install a MacDon approved weight box. For instructions, refer to *Preparing Windrower to Tow a Header, page 146*.
7. Press switch (A) to turn on lights. Always use these lights on roads to provide warning to other vehicles.
8. Use high/low switch (B) as required when other vehicles are approaching.

IMPORTANT:

Do **NOT** use field lights on the road; they may confuse other drivers.

9. Press switch (C) to turn on the beacons.
10. Press switch (D) to turn on the hazard lights.

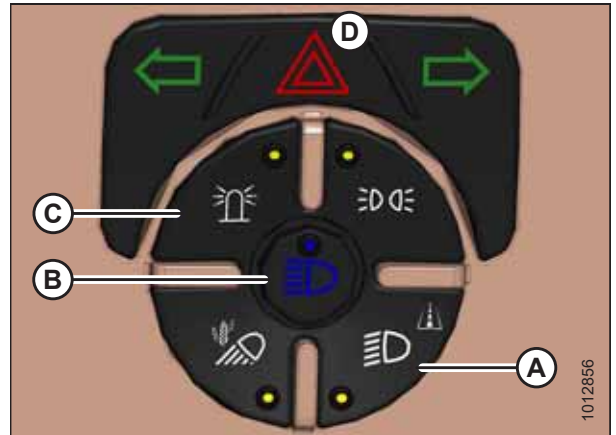

Figure 4.52: Light Switches

11. Set the desired maximum ground speed limit. For instructions, refer to *Adjusting Ground Speed Limit, page 130*.

NOTE:

Maximum ground speed can be set while the windrower is moving. Anticipate acceleration or deceleration if changing maximum speed while moving.

12. Slowly push throttle (A) to full forward (operating speed).

WARNING

Check to be sure all bystanders have cleared the area.

13. Move the GSL (B) out of PARK and slowly forward to the desired speed.

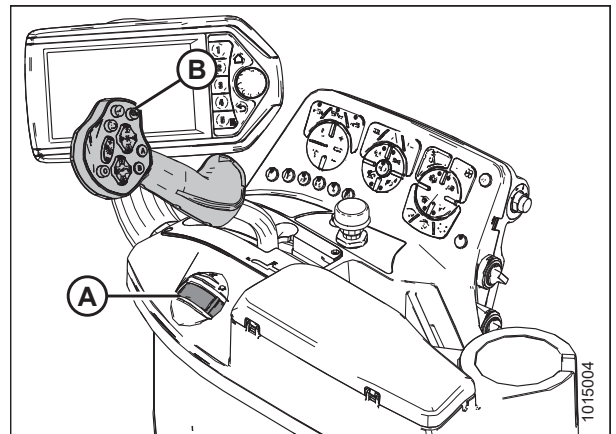

Figure 4.53: Console

 **WARNING**

To avoid serious injury or death from loss of control:

- Do NOT make abrupt changes in steering direction.
- Anticipate turns and steep slopes by slowing down well in advance. Before making an abrupt turn, pull back on the ground speed lever (GSL) as steering is more responsive at reduced speeds.
- Do NOT rapidly accelerate or decelerate while turning.

When traveling on steep slopes:

- Move GSL closer to NEUTRAL to reduce speed.
- Lower the header.
- If the ground speed is greater than or equal to 51 km/h (30 mph), the HPT will display a warning message (SLOW DOWN) with an audible alert. Move GSL closer to NEUTRAL to reduce speed.

With the header removed, steering control is reduced if weight is not added to drive wheels. If you must drive the windrower without a header or MacDon weight system:

- Do NOT exceed the minimum speed setting.
- Avoid loose gravel and slopes.
- Do NOT tow a header.
- If you lose control of machine, immediately pull the ground speed lever (GSL) to NEUTRAL.

Towing Header with Windrower

The windrower can be used to tow a MacDon draper header that has the Slow Speed Transport option installed. Ensure the optional weight box is installed on the windrower to transfer weight to the lift arms. For instructions, refer to [Preparing Windrower to Tow a Header, page 146](#).

WARNING

- A windrower without a header or weight box must NOT be used to tow headers due to reduced traction and possible loss of control.
- For towed equipment without brakes, do NOT exceed 32 km/h (20 mph).

CAUTION

- To tow a header with an M1240 Windrower, the header must be equipped with the appropriate equipment to comply with local regulations.
- Before towing, verify signal lighting and safety equipment is installed and functioning properly.
- Do NOT exceed the combined gross vehicle weight (CGVW) specified in [Table 4.3, page 145](#).
- To prevent damage and/or loss of control, ensure the machine and attached equipment are within the following weight limits:

Table 4.3 Maximum Weight

		kg	lb.
Maximum GVW (includes mounted implements)		10,660	23,500
Maximum CGVW (includes towed and mounted implements)		11,793	26,000
Weight on both drive wheels (A)	Maximum	8618	19,000
	Minimum	4568	10,070
Maximum weight on both caster tires (B)		2744	6050



Figure 4.54: Towing a Header

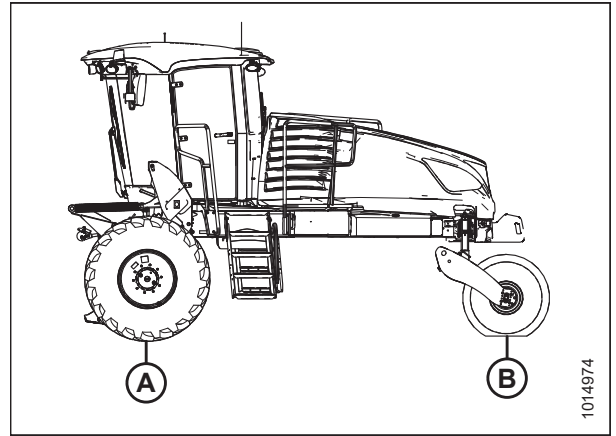

Figure 4.55: Maximum Weight

Preparing Windrower to Tow a Header

1. Attach the header to the windrower. For instructions, refer to *Attaching D1X or D1XL Series Draper Header, page 163*.



Figure 4.56: Windrower with Header

2. Convert the header to transport mode. For instructions, refer to header operator's manual.
3. Detach the header from the windrower. For instructions, refer to *Detaching D1X or D1XL Series Draper Header, page 171*.
4. Remove hairpin (D) and clevis pin (C) securing header support (B) to leg (A). Retain pins for attaching the weight box.
5. Remove header support (B) from windrower lift leg (A).
6. Repeat above step for opposite support.

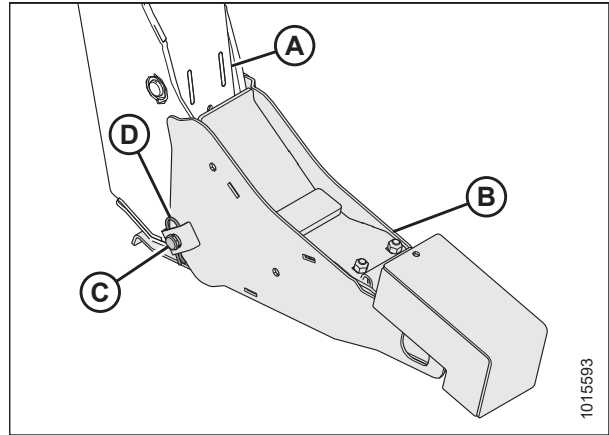

Figure 4.57: Draper Header Support

7. Drive windrower so that lift legs (A) are positioned in weight box pockets (B). Raise the lift legs slightly.
8. Shut down the engine, and remove the key from the ignition.
9. Install locking pin (C) into the pocket and secure with hairpin (D). Repeat for the opposite leg.

NOTE:

The pins were previously removed from the header supports.

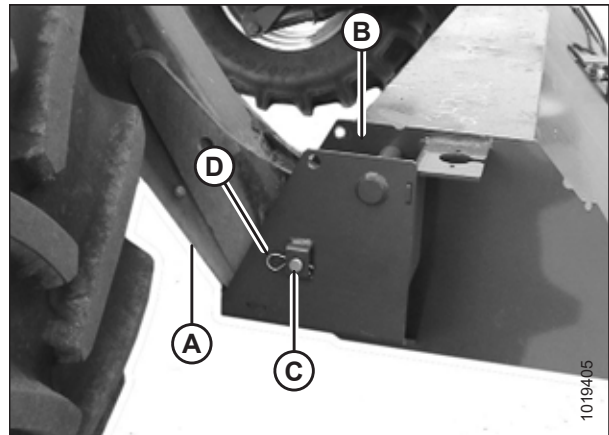

Figure 4.58: Windrower Lift Linkage

OPERATION

10. Attach slow speed transport hitch (A) to the weight box tongue (B) with the drawbar pin, and secure with the lynch pin. Attach safety chain (C).
11. Connect the hitch harness to the electrical socket at the front of the weight box.

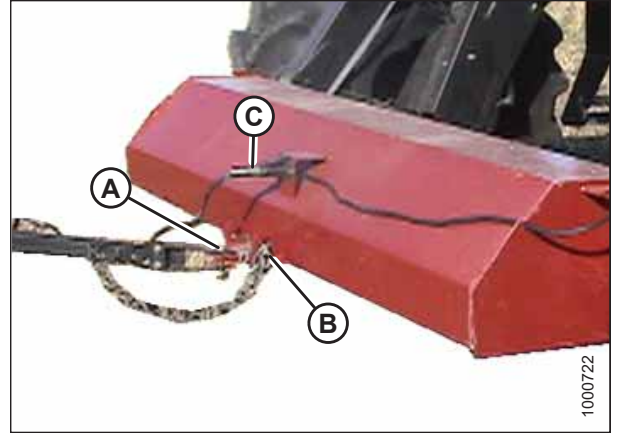

Figure 4.59: Weight Box

12. Start the engine.
13. Raise the weight box until the tow bar is level. The header is now ready for transport. For instructions, refer to [Towing Header with Windrower, page 145](#).



Figure 4.60: Towing a Header

OPERATION

Towing the Windrower – Emergency

Towing the windrower is **NOT** recommended. If the windrower gets stuck, or must be towed onto a truck or trailer, follow these steps:

IMPORTANT:

- **NEVER** attempt to start the windrower by towing it. Serious damage to the final drives may occur.
- Failure to disengage the final drives before towing will result in serious transmission damage.
- Only tow the windrower for a short distance, on level ground, and at slow speed.

⚠ DANGER

Uncontrolled heavy equipment. With final drives disengaged (turned inward), brakes and steering do NOT work. After towing, place blocks under front and rear wheels to prevent uncontrolled movement.

1. Before towing the vehicle, disengage the final drives. For instructions, refer to *Engaging and Disengaging Final Drives, page 149*.
2. Use attachment point (A) to tow if the windrower gets stuck, or when pulling onto a truck or trailer for transport.
3. When towing is complete, place blocks under the front and rear wheels to prevent uncontrolled movement.
4. Engage final drives. For instructions, refer to *Engaging and Disengaging Final Drives, page 149*.

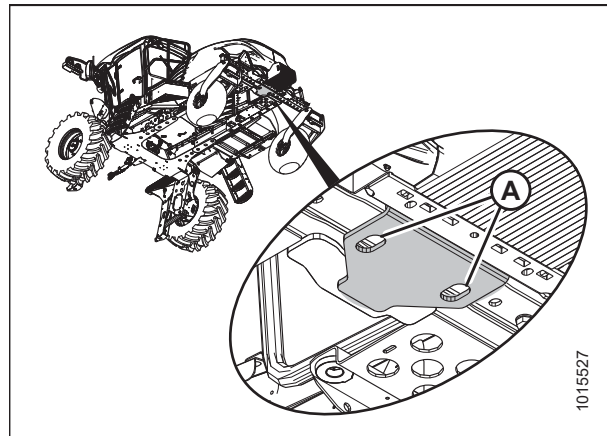

Figure 4.61: Emergency Towing

OPERATION

Engaging and Disengaging Final Drives

Disengage and engage final drives as follows:

WARNING

Park on a flat, level surface, and chock wheels to prevent unexpected rolling when disengaging final drive.

1. Park the windrower on a level surface.
2. Remove two bolts (A) at the center of the drive wheel.
3. Remove cap (B) and flip it over so that the convex side faces in. The cap presses a pin that disengages the gearbox.
4. Reinstall bolts (A) to secure cap (B).
5. Repeat the previous steps on the other drive wheel.
6. After towing, reverse cap (B) to engage the final drives. Be sure the pin at the center of the wheel pops out to engage the drive.

NOTE:

Engaging the final drives may require rocking the wheels slightly.

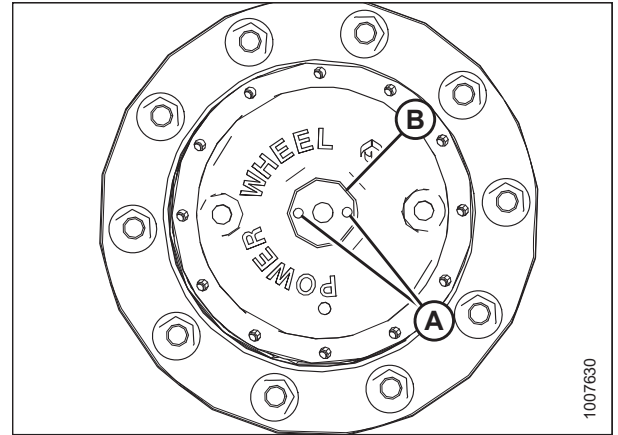

Figure 4.62: Final Drives – 10 Bolt

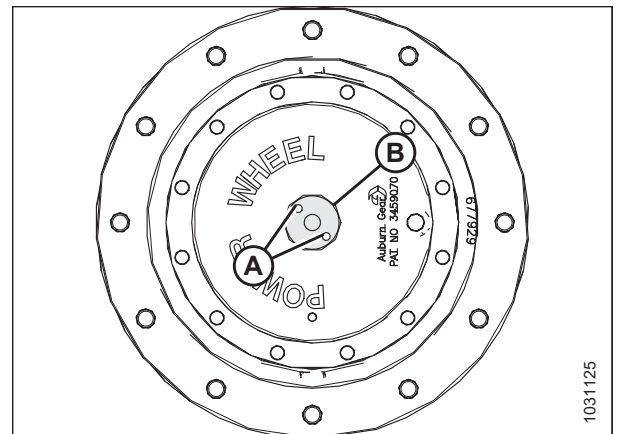

Figure 4.63: Final Drives – 12 Bolt (Optional)

4.3.8 Storing the Windrower

Follow these steps to prepare your windrower for storage at the end of the season:

WARNING

NEVER use gasoline, naphtha, or any volatile material for cleaning purposes. These materials are toxic and can be flammable.

WARNING

NEVER operate engine in a enclosed building. Proper ventilation is required to avoid exhaust gas hazards.

WARNING

When working with batteries, remove metal jewelry and NEVER allow a metal object (such as a wrench) to touch across the battery terminals. A short circuit can produce an extremely hot spark causing severe injuries.

1. Retract all cylinders to protect the cylinder rods from corrosion during storage:
 - Header lift cylinders
 - Float cylinders
 - Header tilt cylinder
2. Check for broken components and order replacements from your Dealer. Attending to these items right away will save time and effort at the beginning of the next season.
3. Tighten loose hardware and replace any missing hardware. Refer to *8.1 Torque Specifications, page 459*.
4. Clean the windrower thoroughly.
5. Repaint all worn or chipped painted surfaces to prevent rust.
6. Fill the fuel tank to prevent condensation.
7. When storing for **6 MONTHS OR LONGER**, drain the diesel exhaust fluid (DEF) tank. For instructions, refer to *Draining the Diesel Exhaust Fluid Tank, page 307*.
8. Change the oil to remove acids and other by-products of combustion from the engine.
9. Test engine coolant antifreeze concentration to ensure it is sufficient to protect engine against lowest expected temperature.
10. Drain the windshield washer tank or ensure the fluid can endure the lowest expected temperatures.
11. Lubricate the windrower thoroughly, leaving excess grease on fittings to keep moisture out of bearings. Apply grease to exposed threads and sliding surfaces of components.
12. Remove the batteries. For instructions, refer to *Removing a Battery, page 391*. Bring batteries to full charge, and store in a cool, dry place not subject to freezing.
13. If possible, block up windrower to take weight off the tires. If this is not possible, increase tire pressure by 25% for storage. Adjust to recommended operating pressure before next use.

IMPORTANT:

Do **NOT** exceed the maximum pressure specified on the tire sidewall.

14. Store the windrower in a dry, protected place.
15. If stored outside, seal the air cleaner intake and exhaust pipe with plastic bags and/or waterproof tape.
16. If stored outside, cover the windrower with a breathable cover. Avoid plastic covers that can trap humidity.

4.4 Attaching and Detaching a Header

4.4.1 A40DX Auger Header

Attaching A40DX Auger Header

The windrower may have an optional self-aligning hydraulic center-link that allows vertical position control of the center-link from the cab.

WARNING

To avoid bodily injury or death from unexpected startup of machine, always stop engine and remove key from ignition before leaving operator's seat for any reason.

1. Remove hairpin (A) from pin (B), and remove the pin from header supports (C) on both sides of the header.

WARNING

Check to be sure all bystanders have cleared the area.

2. Start the engine.

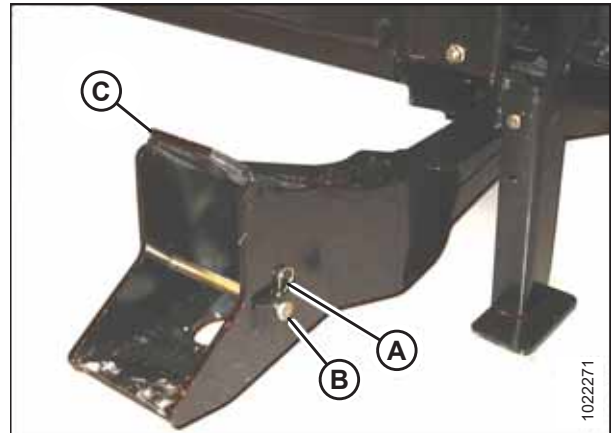

Figure 4.64: Header Support

3. If lowering the header lift legs **WITH** a header or weight box attached, proceed to Step 7, page 152.

If lowering the header lift legs **WITHOUT** a header or weight box attached to the windrower, fully release the tension in header float springs (A):

- If prompted by the Harvest Performance Tracker (HPT) to remove the float, then remove the float and proceed to Step 7, page 152.
- If not prompted by the HPT to remove the float, then proceed to Step 4, page 152 to remove the float manually.

IMPORTANT:

When lowering the header lift legs without a header or weight box attached to the windrower, ensure the float springs tension is fully released to prevent damage to the header lift linkages.

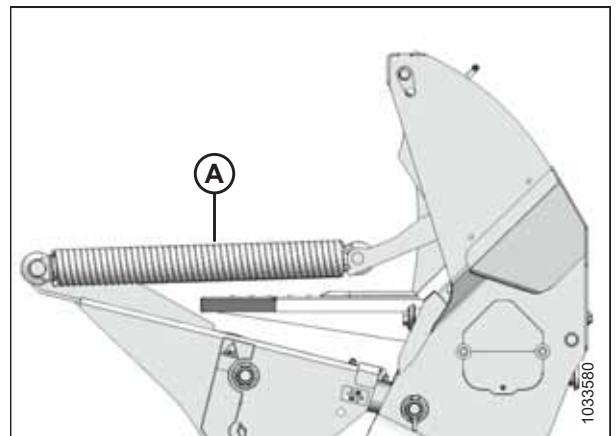

Figure 4.65: Header Float Springs

OPERATION

4. Press HPT scroll knob (A) to highlight QuickMenu options.
5. Rotate HPT scroll knob (A) to highlight the HEADER FLOAT symbol (B) and press the scroll knob to select.



Figure 4.66: HPT Display

6. On FLOAT ADJUST PAGE, press soft key 3 (A) to remove float.



Figure 4.67: HPT Display

7. Press HEADER DOWN switch (A) on the ground speed lever (GSL) to fully retract header lift cylinders.
8. **If the hydraulic center-link self-alignment kit is installed:** press REEL UP switch (B) on the GSL to raise the center-link until the hook is above the attachment pin on the header.

IMPORTANT:

If the center-link is too low, it may contact the header as the windrower approaches the header for hookup.



Figure 4.68: GSL

OPERATION

9. **If the hydraulic center-link self-alignment kit is NOT installed:** relocate pin (A) in the frame linkage as required to raise center-link (B) until the hook is above the attachment pin on the header.

IMPORTANT:

If the center-link is too low, it may contact the header as the windrower approaches the header for hookup.

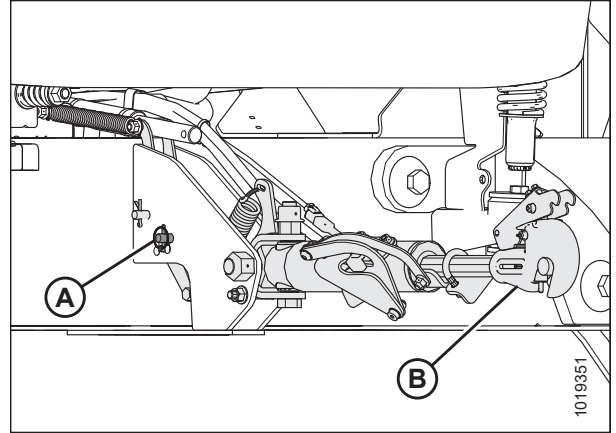

Figure 4.69: Hydraulic Center-Link without Self-Alignment Kit

10. Drive the windrower slowly forward so feet (A) on the windrower enter supports (B) on the header. Continue to drive slowly forward until the feet engage the supports, and the header nudges forward.

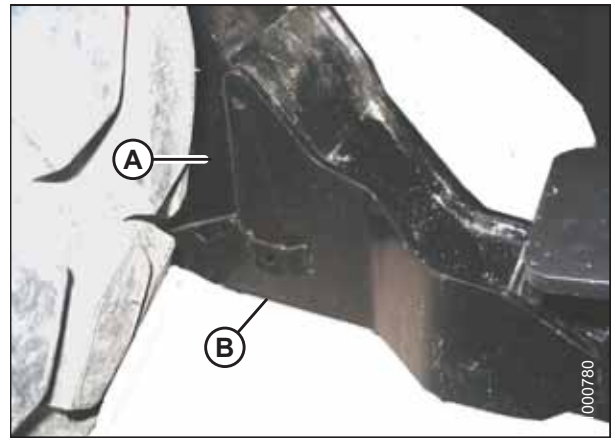

Figure 4.70: Header Support

11. **If the hydraulic center-link self-alignment kit is installed:** adjust position of center-link cylinder (A) with switches on the GSL until hook (B) is above the header attachment pin.
12. **If the hydraulic center-link self-alignment kit is NOT installed:** push down on the rod end of link cylinder (C) until the hook engages and locks onto the header pin.

IMPORTANT:

Hook release (D) must be down to enable the self-locking mechanism. If the release is open (up), manually push it down after the hook engages the header pin.

13. **If the hydraulic center-link self-alignment kit is installed:** lower center-link (A) onto the header with REEL DOWN switch on the GSL until it locks into position (hook release [D] is down).
14. **If the hydraulic center-link self-alignment kit is installed:** check that the center-link is locked onto header by pressing the REEL UP switch on the GSL.

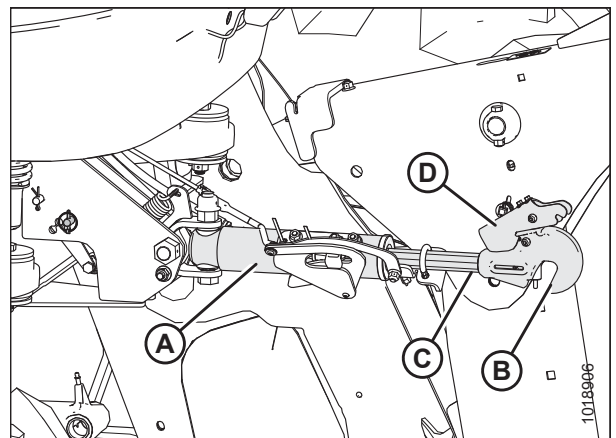

Figure 4.71: Hydraulic Center-Link

OPERATION

WARNING

Check to be sure all bystanders have cleared the area.

15. Press HEADER UP switch (A) to raise the header to maximum height.
16. If one end of the header does **NOT** fully raise, rephase the lift cylinders as follows:
 - a. Press and hold HEADER UP switch (A) until both cylinders stop moving.
 - b. Continue to hold the switch for 3–4 seconds. Cylinders are now phased.

NOTE:

This procedure may have to be repeated if there is air in the system.

17. Shut down the engine, and remove the key from the ignition.
18. Engage the safety props on both lift cylinders as follows:
 - a. Pull lever (A) toward you to release, and then rotate toward header to lower the safety prop onto the cylinder.
 - b. Repeat for the opposite lift cylinder.

IMPORTANT:

Ensure the safety props engage over the cylinder piston rods. If the safety prop does **NOT** engage properly, raise the header until the safety prop fits over the rod.

19. Install clevis pin (A) through the support and foot, and secure with a hairpin. Repeat for the opposite support.

IMPORTANT:

Ensure clevis pin (A) is fully inserted and the hairpin is installed behind bracket.



Figure 4.72: GSL

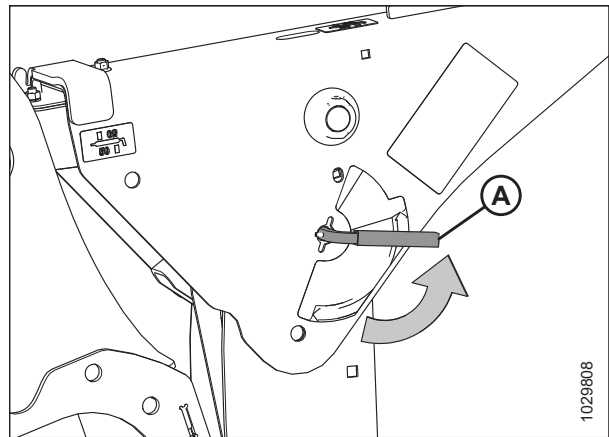

Figure 4.73: Safety Prop Lever

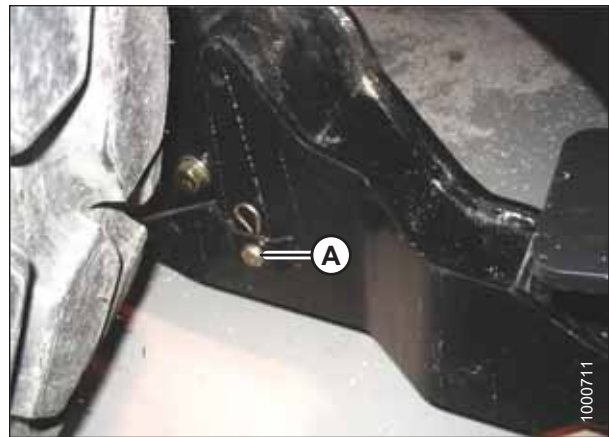

Figure 4.74: Header Support

OPERATION

20. Remove the lynch pin from clevis pin (A) in stand (B).
21. Hold stand (B) and remove pin (A).
22. Move the stand to storage position by inverting and relocating onto bracket as shown. Reinsert clevis pin (A) and secure with the lynch pin.

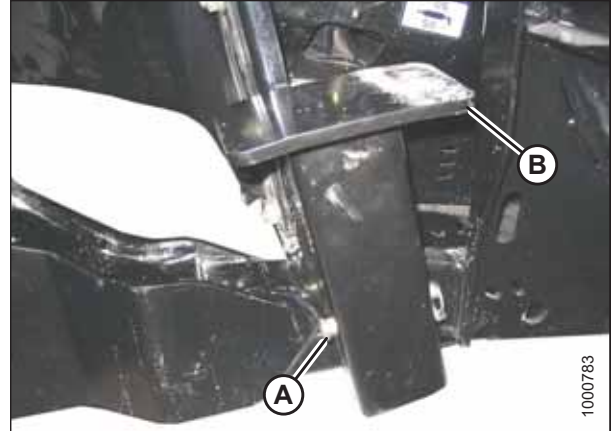

Figure 4.75: Header Stand

23. Disengage the safety props on both lift cylinders as follows:
 - a. Turn lever (A) away from the header to raise the safety prop until the lever locks into the vertical position.
 - b. Repeat for the opposite cylinder.

NOTE:

If the safety prop will **NOT** disengage, raise the header to release the prop.

24. Repeat for the opposite side.

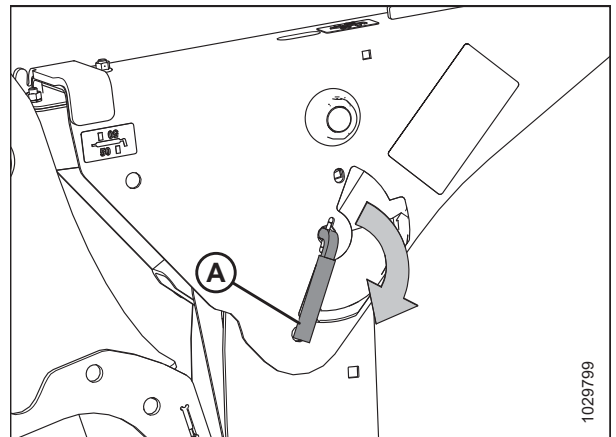

Figure 4.76: Safety Prop Lever



WARNING

Check to be sure all bystanders have cleared the area.

25. Start the engine and press HEADER DOWN switch (A) on GSL to fully lower the header.

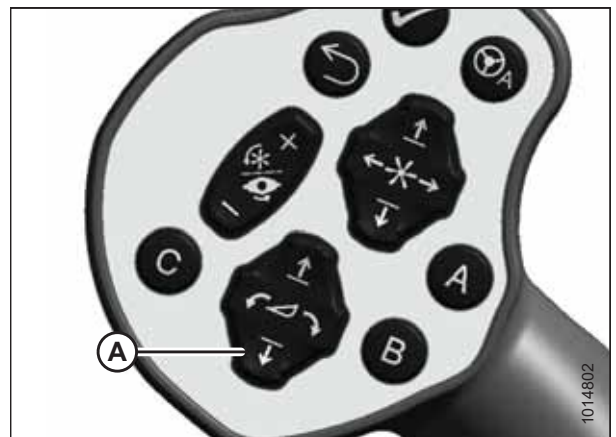

Figure 4.77: GSL

OPERATION

26. Press rotary scroll knob (A) on the HPT to highlight the QuickMenu options.
27. Rotate scroll knob (A) to highlight HEADER FLOAT symbol (B). Press the scroll knob to select.



Figure 4.78: HPT Display

28. Turn scroll knob (A) to highlight left (B) or right (C) float and press knob (A) to activate selection.
29. Rotate scroll knob (A) to adjust the float setting and press the knob when finished.

IMPORTANT:

Float adjustments of 1.0 (out of 10) change the header weight at the cutterbar by approximately 91 kg (200 lb.). Adjust the float in increments of 0.05 to optimize field performance.

30. Shut down the engine, and remove the key from the ignition.
31. Grasp one end of the auger header and lift. Lifting force should be 335–380 N (75–85 lbf) at both ends.
32. Proceed to [Connecting A40DX Auger Hydraulics, page 157](#).



Figure 4.79: HPT Display

Connecting A40DX Auger Hydraulics

CAUTION

Do NOT stand on an unlocked platform. It is unstable and may cause you to fall.

1. Approach platform (A) on the left cab-forward side of the windrower and ensure the cab door is closed.
2. Push latch (B), and pull platform (A) toward the walking beam until it stops and the latch engages.

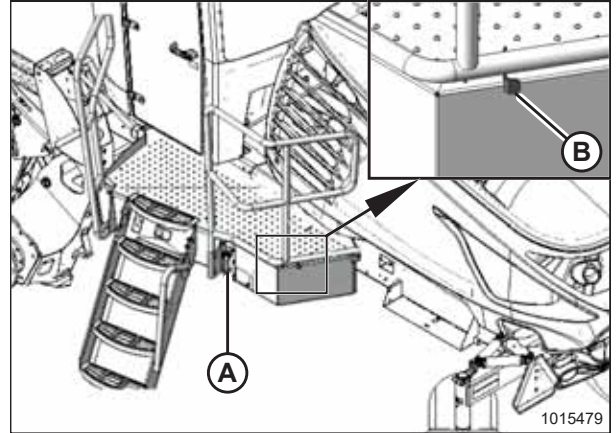

Figure 4.80: Left Cab-Forward Platform

3. Retrieve hydraulic multicouplers (A) and electrical harness (B) from the header.
4. Route the hose/harness bundle toward the windrower through support (C).

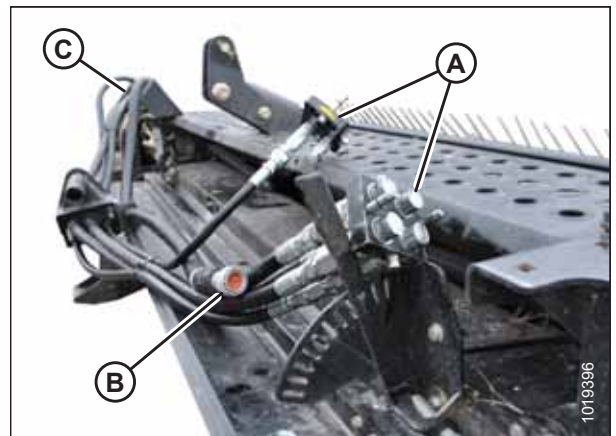

Figure 4.81: Hydraulic Hoses in Storage Position

5. Insert hose support (B) into hole (A) in the windrower left leg, and route the header hose bundle (C) under the windrower to the hydraulic and electrical couplers.

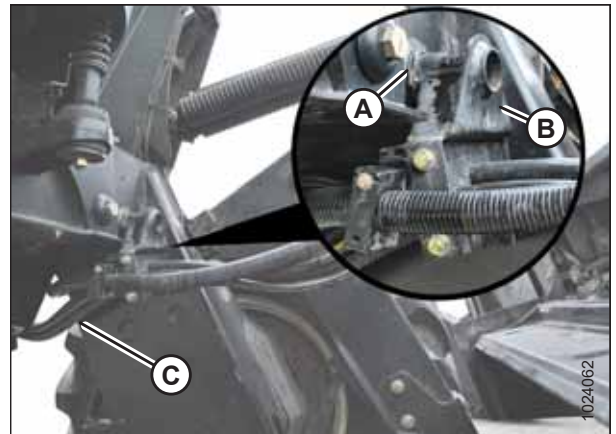

Figure 4.82: Multicoupler

OPERATION

6. Clean the multicouplers and receptacles to prevent contamination.
7. Push button (A) on the rear multicoupler receptacle and rotate handle (B) away from the windrower.
8. Open cover (C) and position multicoupler (D) onto the receptacle. Align the pins in the coupler with slots in handle (B), and rotate the handle toward the windrower so that the coupler is locked onto the receptacle and button (A) snaps out.
9. Push button (E) on the front multicoupler receptacle and rotate handle (F) away from the windrower.
10. Open cover (G) and position multicoupler (H) onto the receptacle. Align the pins in the coupler with slots in the handle, and rotate the handle toward the windrower so that the coupler is locked onto the receptacle and button (E) snaps out.
11. Remove cover from receptacle (A), and connect the electrical harness from the header.

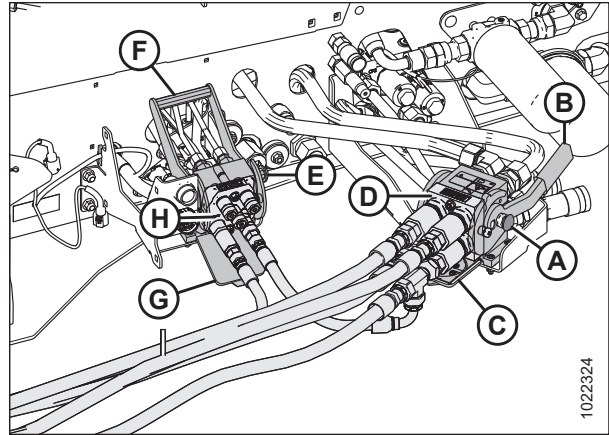

Figure 4.83: Knife/Reel/Auger Drive Multicoupler

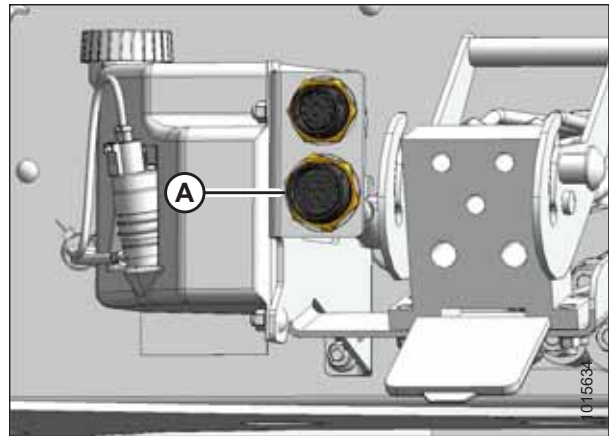

Figure 4.84: Electrical Connectors

Detaching an A40DX Auger Header

⚠ DANGER

To avoid bodily injury or death from unexpected start-up or fall of a raised machine, always stop engine and remove key before leaving the operator's seat, and always engage safety props before going under the machine for any reason.

1. Start the engine and press HEADER UP button (A) on the ground speed lever (GSL) to raise the header to maximum height.
2. If one end of the header does **NOT** raise fully, rephase the cylinders as follows:
 - a. Press and hold HEADER UP (A) switch until both cylinders stop moving.
 - b. Continue to hold the switch for 3–4 seconds. Cylinders are now phased.
3. Shut down the engine, and remove the key from the ignition.



Figure 4.85: GSL

4. Engage the safety props on both lift cylinders as follows:
 - a. Pull lever (A) toward you to release, and then rotate toward header to lower the safety prop onto the cylinder.
 - b. Repeat for the opposite lift cylinder.

IMPORTANT:

Ensure the safety props engage over the cylinder piston rods. If the safety prop does **NOT** engage properly, raise the header until the safety prop fits over the rod.

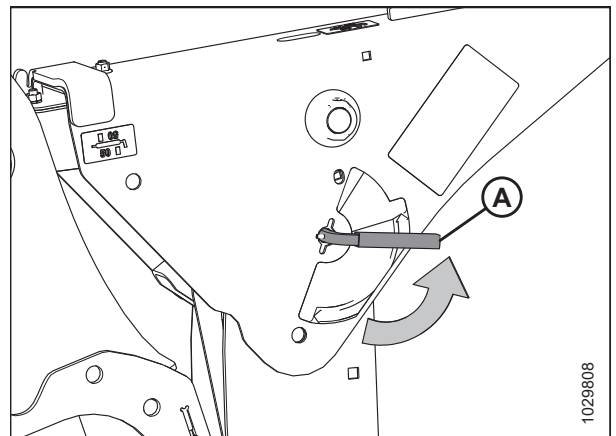

Figure 4.86: Safety Prop Lever

5. Remove the hairpin from clevis pin (A) and remove the clevis pin from header support (B) on both sides.

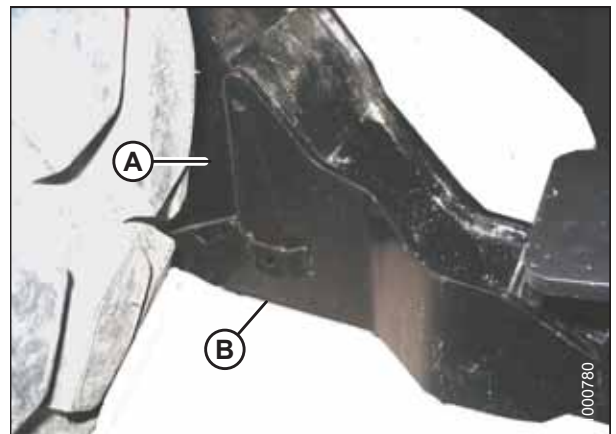

Figure 4.87: Header Support

OPERATION

- Lower stand (A) by pulling clevis pin (B), inverting stand, and relocating on the bracket. Reinsert pin (B) and secure with the hairpin.

WARNING

Check to be sure all bystanders have cleared the area.

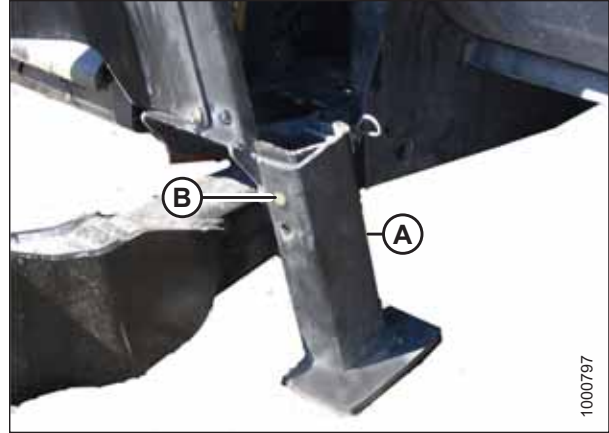

Figure 4.88: Header Stand

- Disengage the safety props on both lift cylinders as follows:
 - Turn lever (A) away from the header to raise the safety prop until the lever locks into the vertical position.
 - Repeat for the opposite cylinder.

NOTE:

If the safety prop will **NOT** disengage, raise the header to release the prop.

- Start the engine.
- Lower the header fully.

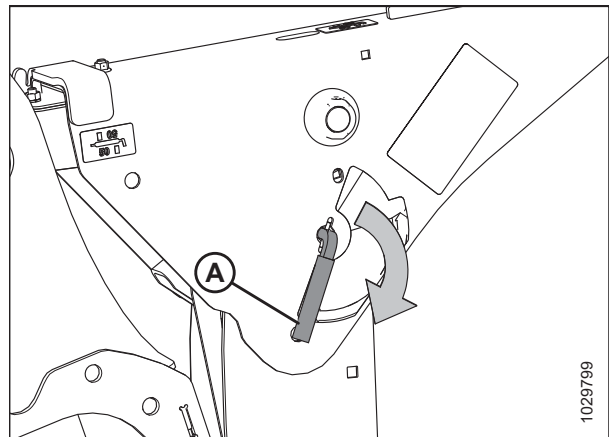

Figure 4.89: Safety Prop Lever

- Activate HEADER TILT UP (A) and HEADER TILT DOWN (B) cylinder switches on the GSL to release the load on the center-link cylinder.
- Shut down the engine, and remove the key from the ignition.

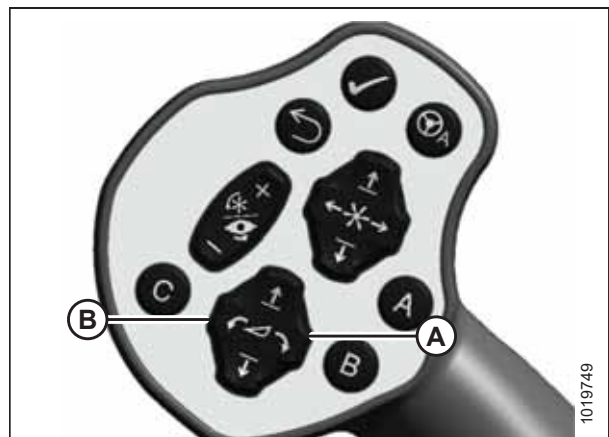

Figure 4.90: GSL

OPERATION

12. Lift hook release (A) and lift hook (B) off header pin.

NOTE:

If the optional center-link self-alignment kit is installed, lift release (A) and then operate the link lift cylinder with the REEL UP switch on the GSL to disengage the center-link from the header.

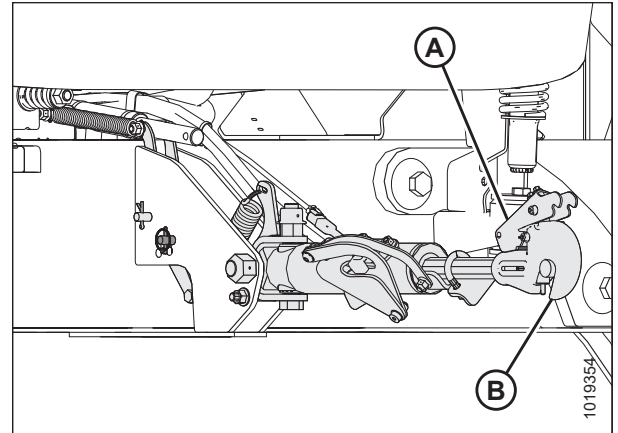

Figure 4.91: Hydraulic Center-Link

13. Disconnect header drive hydraulics (A) and electrical harness (B) from the windrower.

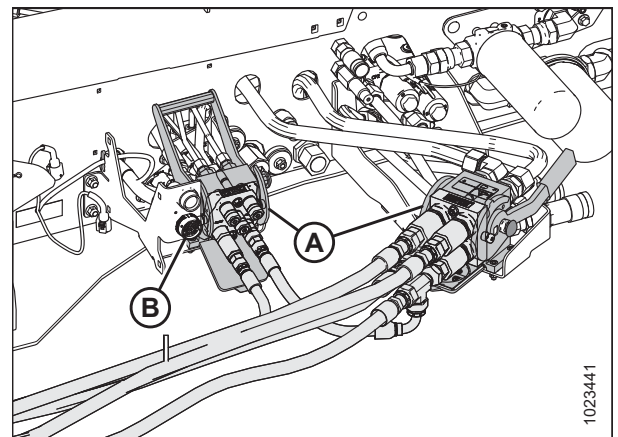

Figure 4.92: Header Drive Hydraulics

14. Place hydraulics/electrical bundle (A) in storage position on the header.
15. Back windrower slowly away from header.

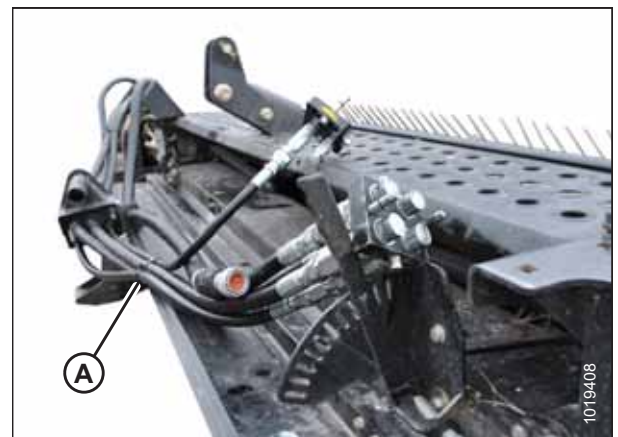

Figure 4.93: Hydraulics Hoses in Storage Position

OPERATION

16. Reinstall clevis pin (B) into header support (C) and secure with hairpin (A). Repeat for the opposite side.

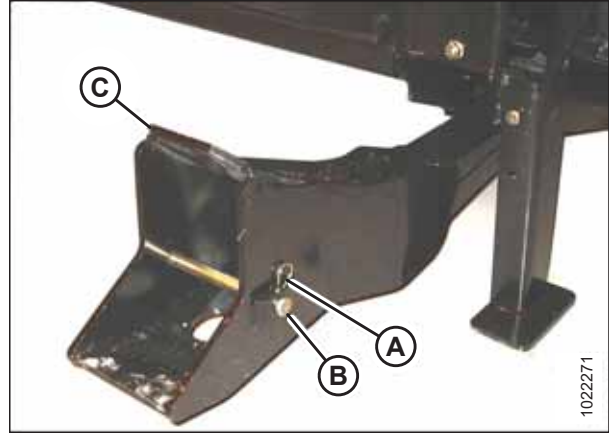

Figure 4.94: Header Support

4.4.2 D1X or D1XL Series Draper Header

Attaching Draper Header Supports

Draper header supports are required to attach a D1X or D1XL Series Draper Header to the windrower.

⚠ WARNING

To avoid bodily injury or death from unexpected startup of the machine, always stop the engine and remove the key from the ignition before leaving the operator's seat for any reason.

If not installed, attach the draper header support (supplied with the header) to the windrower lift linkage as follows:

1. Shut down the engine, and remove the key from the ignition.
2. Remove the hairpin and clevis pin (B) from draper header support (A).

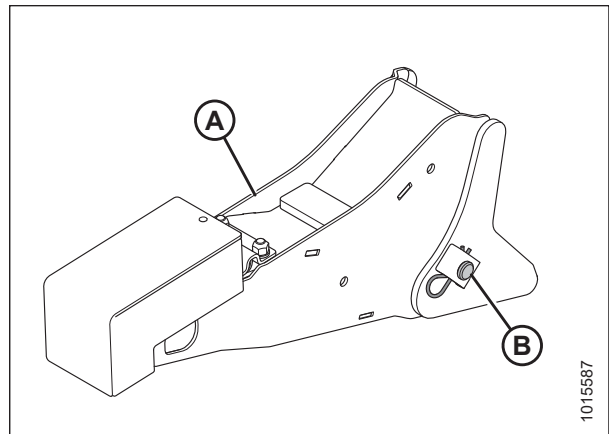

Figure 4.95: Draper Header Support

OPERATION

3. Position draper header support (B) on lift linkage (A), and reinstall clevis pin (C).

NOTE:

To avoid the pin snagging the windrow, install the clevis pin on the outboard side of the draper header support.

4. Secure clevis pin (C) with hairpin (D).
5. Repeat for the opposite lift linkage.

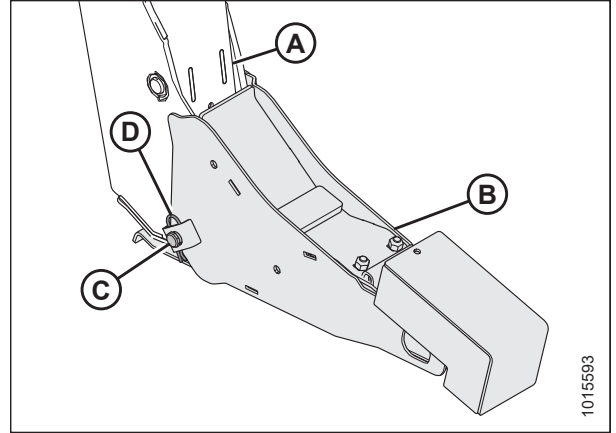

Figure 4.96: Draper Header Support

Attaching D1X or D1XL Series Draper Header

The windrower may have an optional self-aligning hydraulic center-link that allows vertical position control of the center-link from the cab.

NOTE:

Draper header supports must be installed onto the windrower lift linkage before starting this procedure. For instructions, refer to [Attaching Draper Header Supports, page 162](#).



WARNING

To avoid bodily injury or death from unexpected startup of the machine, always stop the engine and remove the key from the ignition before leaving the operator's seat for any reason.

1. Shut down the engine, and remove the key from the ignition.
2. **For windrowers without the self-aligning center-link kit:** Relocate pin (A) in the frame linkage as required to raise center-link (B) until the hook is above the attachment pin on the header.

IMPORTANT:

If the center-link is too low, it may contact the header as the windrower approaches the header for hookup.

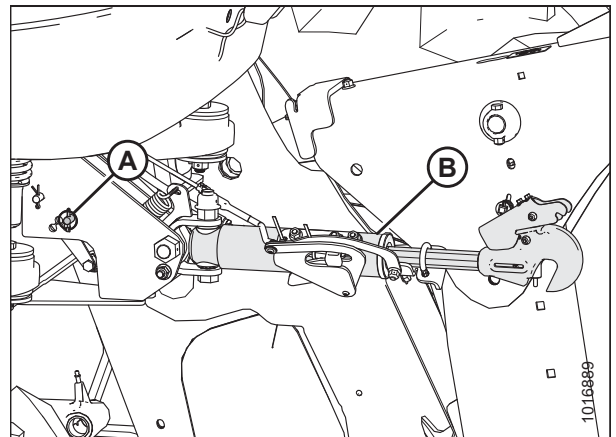

Figure 4.97: Center-Link without Self-Alignment

OPERATION

3. Remove hairpin (A) from pin (B), and remove pin (B) from header leg. Repeat on the opposite header leg.

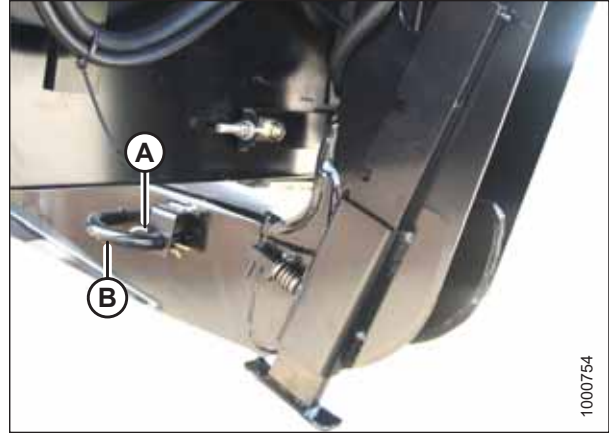

Figure 4.98: Header Leg

WARNING

Check to be sure all bystanders have cleared the area.

4. Start the engine.
5. If lowering the header lift legs **WITH** a header or weight box attached, proceed to Step 9, page 165.

If lowering the header lift legs **WITHOUT** a header or weight box attached to the windrower, fully release the tension in header float springs (A):

- If prompted by the Harvest Performance Tracker (HPT) to remove the float, then remove the float and proceed to Step 9, page 165.
- If not prompted by the HPT to remove the float, then proceed to Step 6, page 165 to remove the float manually.

IMPORTANT:

When lowering the header lift legs without a header or weight box attached to the windrower, ensure the float springs tension is fully released to prevent damage to the header lift linkages.

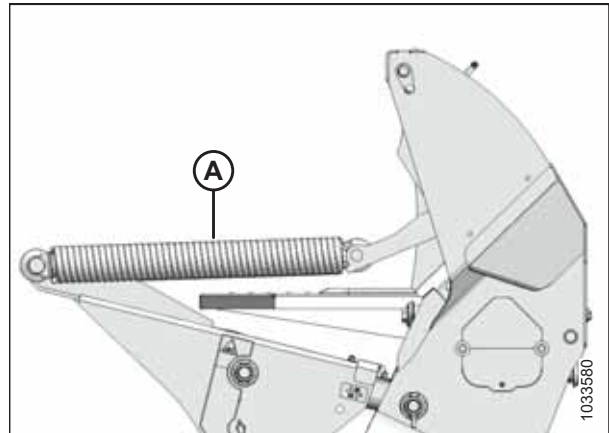

Figure 4.99: Header Float Springs

OPERATION

6. Press scroll knob (A) on the HPT to display the QuickMenu system.
7. Rotate scroll knob (A) to highlight HEADER FLOAT symbol (B), and press the scroll knob to select.



Figure 4.100: HPT Display

8. On the FLOAT ADJUST page, press soft key 3 (A) to remove float.



Figure 4.101: HPT Display

9. **For windrowers equipped with the self-aligning center-link kit:**
 - a. Press HEADER DOWN switch (E) on the ground speed lever (GSL) to fully retract the header lift cylinders.
 - b. Press REEL UP switch (B) on the GSL to raise the center-link until the hook is above the attachment pin on the header.

IMPORTANT:

If the center-link is too low, it may contact the header as the windrower approaches the header for hookup.

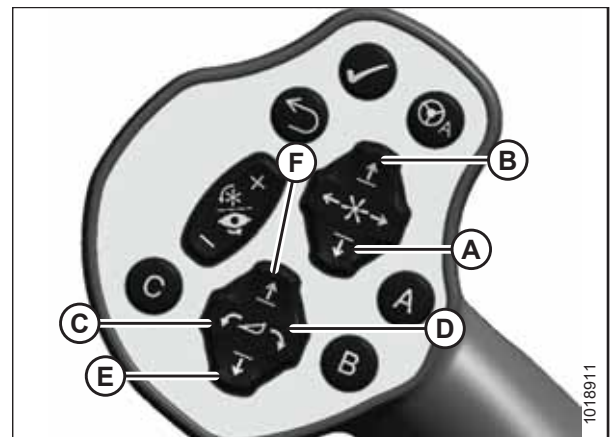

Figure 4.102: GSL Switches

- | | |
|----------------------|--------------------|
| A - Reel Down | B - Reel Up |
| C - Header Tilt Down | D - Header Tilt Up |
| E - Header Down | F - Header Up |

OPERATION

10. Drive the windrower slowly forward until draper header supports (A) enter header legs (B). Continue driving slowly forward until lift linkages contact the support plates in the header legs and the header nudges forward.
11. Ensure that lift linkages are properly engaged in the header legs and are contacting the support plates.

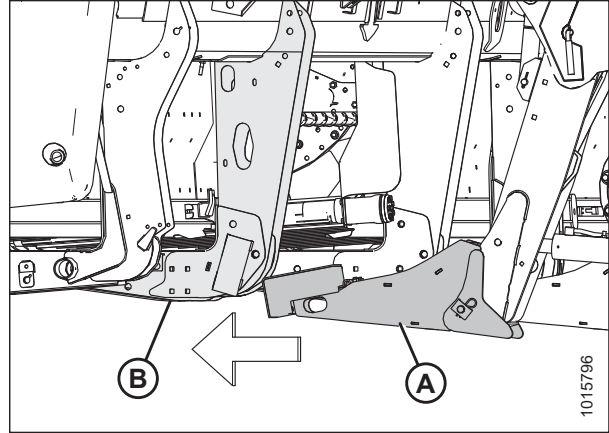

Figure 4.103: Header Leg and Draper Header Support

12. Self-aligning hydraulic center-link:

- a. Adjust the position of center-link cylinder (A) with the switches on the GSL until hook (B) is above the header attachment pin.

IMPORTANT:

Hook release (C) must be down to enable the self-locking mechanism.

- b. If hook release (C) is open (up), shut down the engine, and remove the key from the ignition. Manually push hook release (C) down after the hook engages the header pin.
- c. Lower center-link (A) onto the header with REEL DOWN switch on the GSL until the center-link locks into position and hook release (C) is down.
- d. Check that center-link is locked onto header by pressing the REEL UP switch on the GSL.

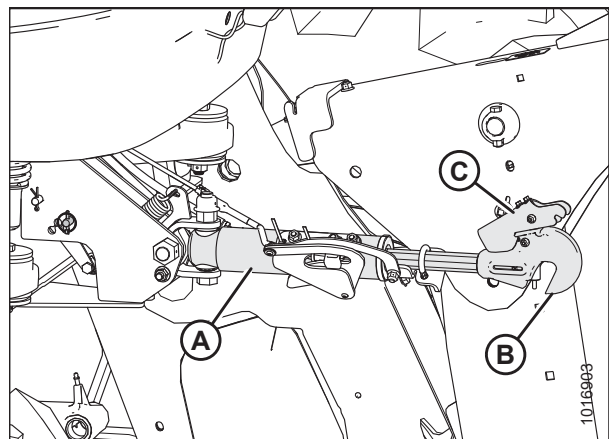

Figure 4.104: Hydraulic Center-Link

OPERATION

13. Hydraulic center-link without self-alignment:

- a. Press the HEADER TILT UP or HEADER TILT DOWN cylinder switches on the GSL to extend or retract the center-link cylinder until the hook is aligned with the header attachment pin.
- b. Shut down the engine, and remove the key from the ignition.
- c. Push down on rod end of link cylinder (B) until the hook engages and locks onto the header pin.

IMPORTANT:

The hook release must be down to enable self-locking mechanism. If the hook release is open (up), manually push it down after hook engages pin.

- d. Check that center-link (A) is locked onto the header by pulling upward on rod end (B) of cylinder.

WARNING

Check to be sure all bystanders have cleared the area.

- e. Start the engine.
14. Press HEADER UP switch (A) to raise header to maximum height.

NOTE:

If one end of the header does **NOT** fully raise, rephase the lift cylinders as follows:

- a. Press and hold HEADER UP switch (A) until both cylinders stop moving.
 - b. Continue to hold the switch for 3–4 seconds. Cylinders are now phased.
15. Shut down the engine, and remove the key from the ignition.

16. Engage the safety props on both lift cylinders as follows:

- a. Pull lever (A) toward you to release, and then rotate toward header to lower the safety prop onto the cylinder.
- b. Repeat for the opposite lift cylinder.

IMPORTANT:

Ensure the safety props engage over the cylinder piston rods. If the safety prop does **NOT** engage properly, raise the header until the safety prop fits over the rod.

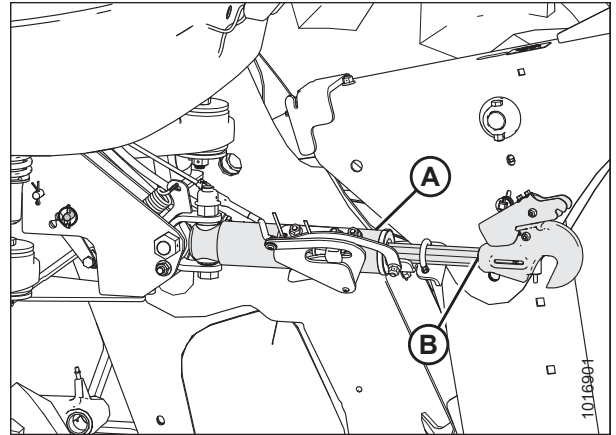

Figure 4.105: Hydraulic Center-Link



Figure 4.106: GSL

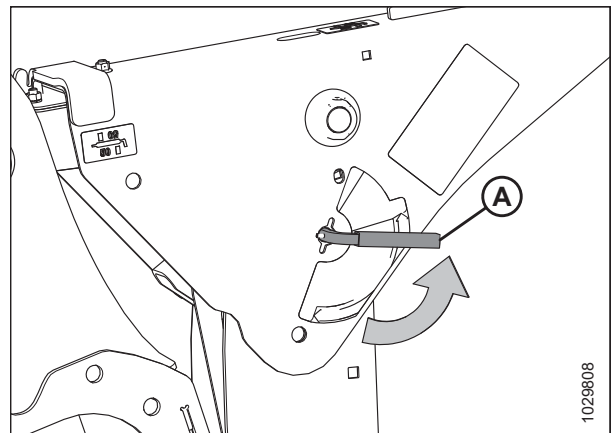

Figure 4.107: Safety Prop Lever

OPERATION

17. Install pin (B) through the header leg (engaging U-bracket in draper header support) on both sides and secure with a hairpin (A).
18. Raise header stand (D) to storage position by pulling spring pin (C) and lifting stand into uppermost position. Release spring pin.

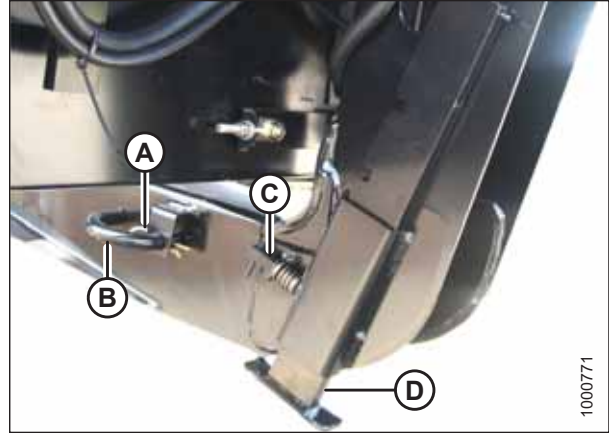

Figure 4.108: Header Leg

19. Disengage the safety props on both lift cylinders as follows:
 - a. Turn lever (A) away from the header to raise the safety prop until the lever locks into the vertical position.
 - b. Repeat for the opposite cylinder.

NOTE:

If the safety prop will **NOT** disengage, raise the header to release the prop.

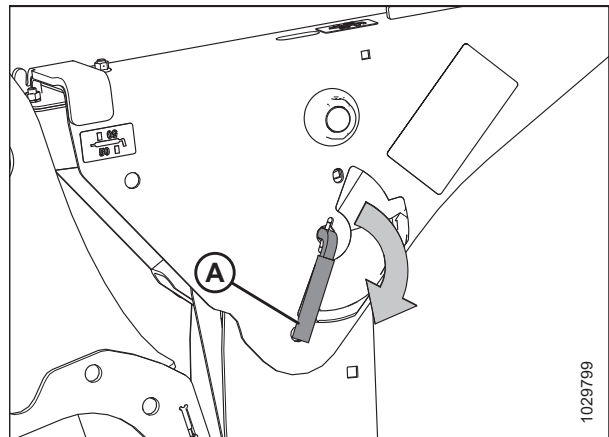

Figure 4.109: Safety Prop Lever

WARNING

Check to be sure all bystanders have cleared the area.

20. Start the engine and press HEADER DOWN switch (A) on the GSL to fully lower the header.

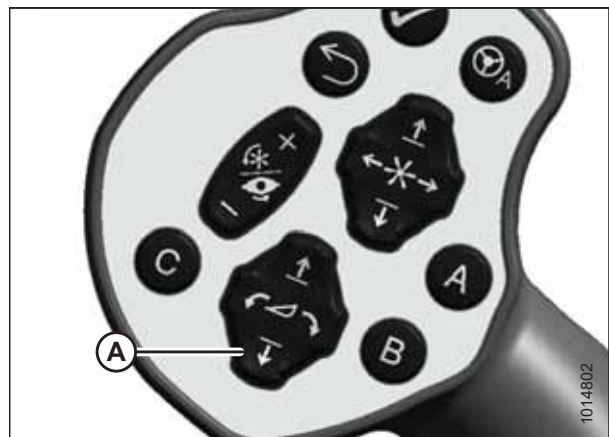

Figure 4.110: GSL

OPERATION

Connecting D1X or D1XL Series Draper Header Hydraulics

IMPORTANT:

To prevent contamination of the hydraulic system, use a clean rag to remove dirt and moisture from all (fixed and movable) hydraulic couplers.

1. Push the link on latch (C) and pull handle (A) on hydraulic hose management system (B) rearward to disengage arm from the latch.
2. Move hydraulic hose management system (B) toward the left cab-forward side of the windrower.

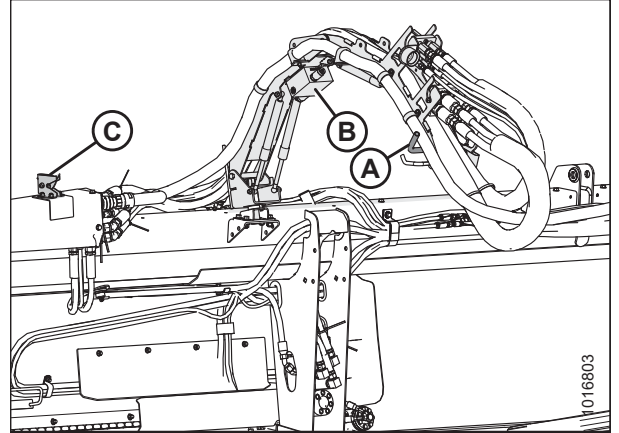

Figure 4.111: Hydraulic Hose Management System

3. Connect hydraulic hose management system (A) to the windrower by securing ball joint (B) into latch support (C) on the windrower leg.
4. Open the platform. For instructions, refer to [5.4.1 Opening Platform, page 304](#).

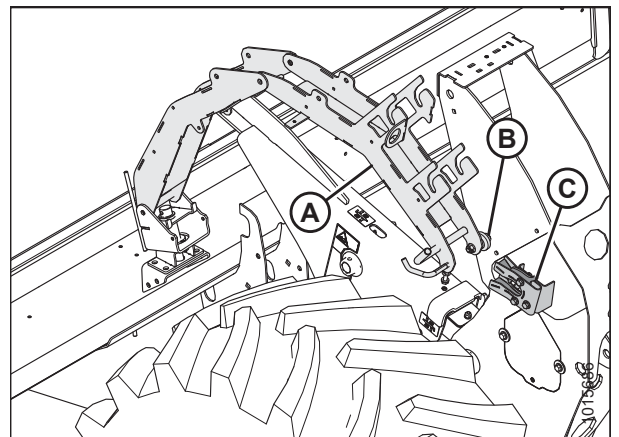

Figure 4.112: Hydraulic Hose Management System

OPERATION

- Retrieve draper drive and reel control multicoupler (A) from the hydraulic hose management system.
- Push knob (B) on the hydraulic receptacle and pull handle (C) fully away from the windrower.
- Open cover (D) and position the coupler onto the receptacle. Align the pins in the coupler with slots in handle (C) and push the handle toward the windrower so that the coupler locks onto the receptacle and knob (B) snaps out.
- Remove hose quick-disconnect (F) from the storage location and connect to receptacle on the frame.

NOTE:

Hose quick-disconnect (F) is only present on M1240 machines configured for draper headers, and on M1170 machines with the R1 Series Hydraulic Drive kit (MD #B6845) installed.

- Remove the cover from electrical connector (E), push the electrical connector onto the receptacle, and secure it by turning the collar on the electrical connector clockwise.
- Retrieve knife and reel drive multicoupler (A) from the hydraulic hose management system.
- Push knob (B) on the hydraulic receptacle and pull handle (C) fully away from the windrower.
- Open cover (D) and position the coupler onto the receptacle. Align the pins in the coupler with the slots in handle (C), and push the handle toward the windrower so that the coupler locks onto the receptacle and knob (B) snaps out.
- Close the platform. For instructions, refer to [5.4.2 Closing Platform, page 304](#).

- Ensure hydraulic hose routing is as straight as possible and avoids potential rub/wear points.

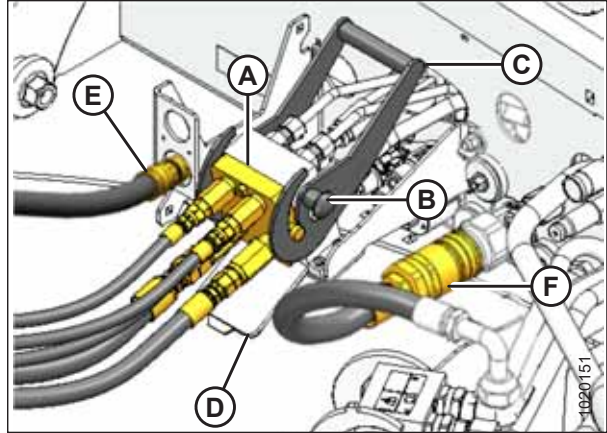

Figure 4.113: Draper/Reel Multicoupler

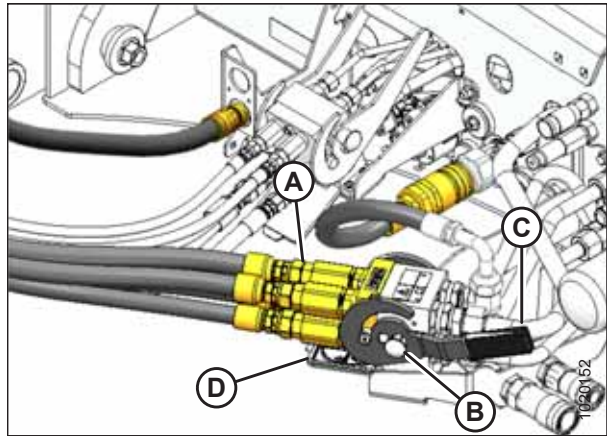

Figure 4.114: Knife/Reel Drive Multicoupler

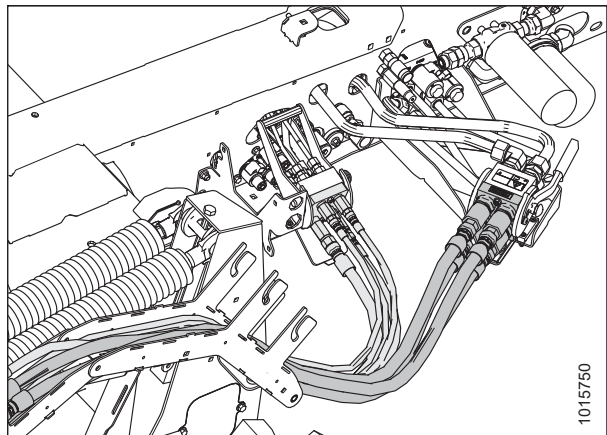

Figure 4.115: Hydraulic Multicouplers and Hose Routing

Detaching D1X or D1XL Series Draper Header

⚠ WARNING

To avoid bodily injury or death from unexpected startup of the machine, always stop the engine and remove the key from the ignition before leaving the operator's seat for any reason.

1. Lower the header fully.
2. Shut down the engine, and remove the key from the ignition.
3. Open the platform. For instructions, refer to [5.4.1 Opening Platform, page 304](#).
4. Push lock button (A) and pull handle (B) to disengage multicoupler (C). Disconnect the hydraulics from the rear knife/reel drive receptacle.

NOTE:

Firmly hold handle (B) when disconnecting multicoupler (C). Pressure may cause the handle to kick back with force.

5. Route knife/reel drive hose bundle back to storage position (D) on the hydraulic hose management system.
6. Remove any debris that may have accumulated on the receptacle. Close cover (E).

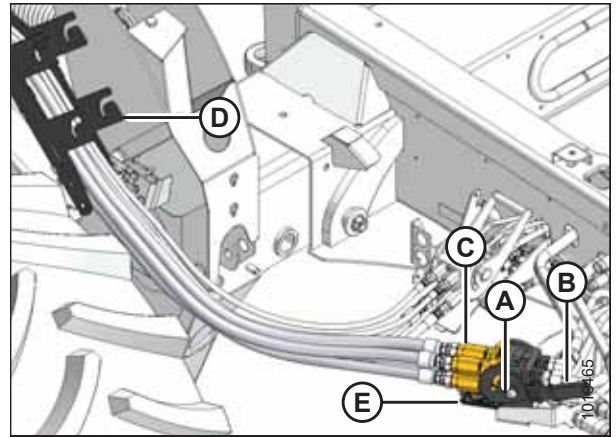

Figure 4.116: Knife/Reel Drive Multicoupler

7. Push lock button (B), and pull handle (C) to disengage multicoupler (A). Disconnect the hydraulics from the windrower draper drive/reel lift receptacle.
8. Disconnect electrical connector (E).
9. Remove any debris that may have accumulated on the windrower front receptacle, and close cover (D).

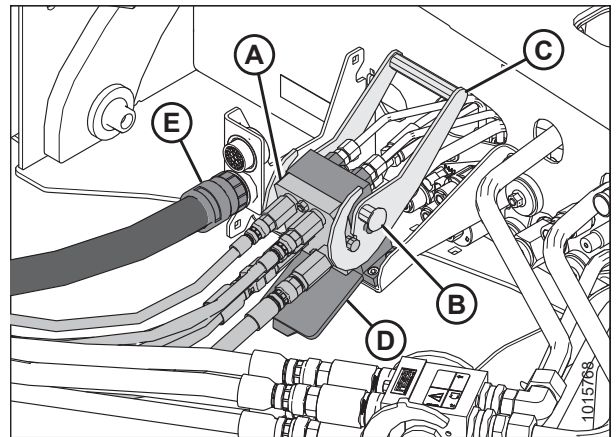

Figure 4.117: Draper/Reel Multicoupler

OPERATION

10. Route draper drive/reel hose bundle back to storage position (A) on hydraulic hose management system (B).
11. Insert electrical connector into storage cup (C).
12. Close the platform. For instructions, refer to [5.4.2 Closing Platform, page 304](#).

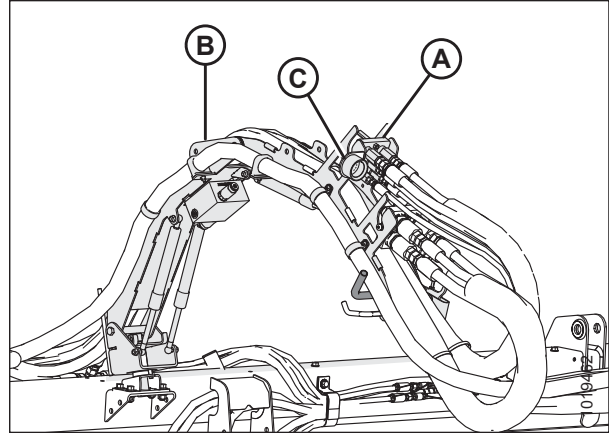

Figure 4.118: Hydraulic Hose Management System

13. Disconnect hose management system (A) from windrower by pulling latch lever (B) to open the latch. Keep latch open and move hose management system (A) away from header with handle (C).

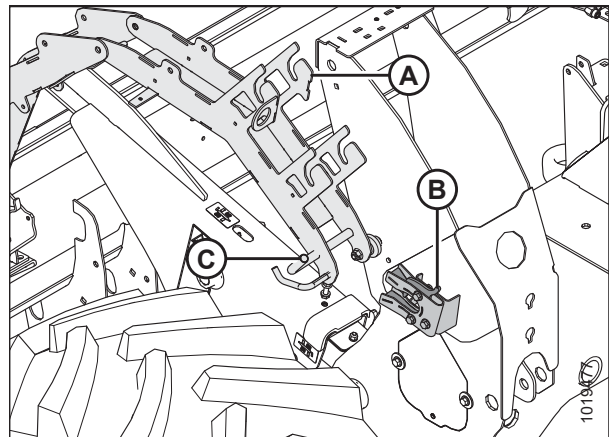

Figure 4.119: Hydraulic Hose Management System

14. Pivot hose management system (B) forward with handle (A), and engage hook (D) into latch (C) on header.

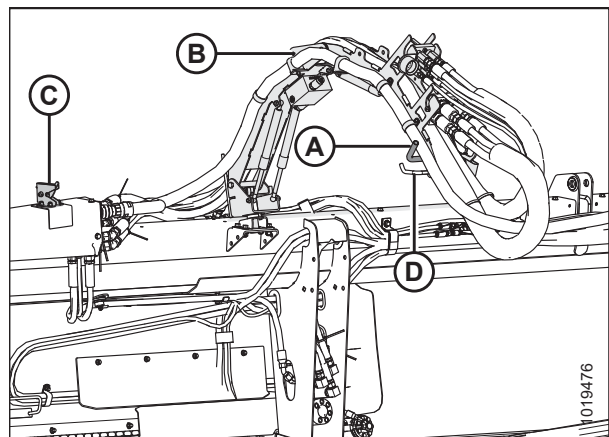

Figure 4.120: Hydraulic Hose Management System

OPERATION

15. Remove the header leg pin (B) by removing the hairpin (A) from header leg on both sides.
16. Lower header stand (D) by pulling spring loaded pin (C). Release spring pin to lock stand.

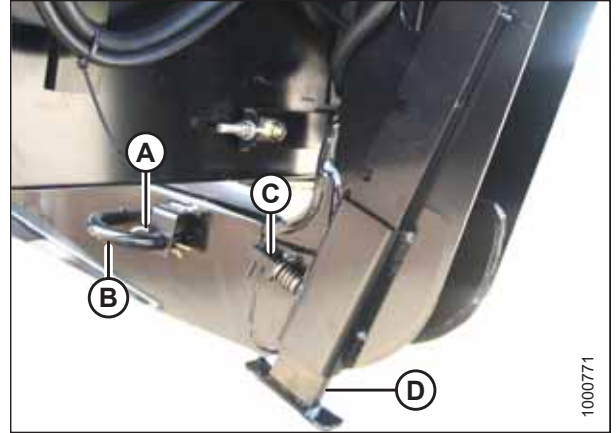

Figure 4.121: Header Stand

17. **Windrowers with self-aligning center-link:** Release center-link latch (A) before returning to the cab.

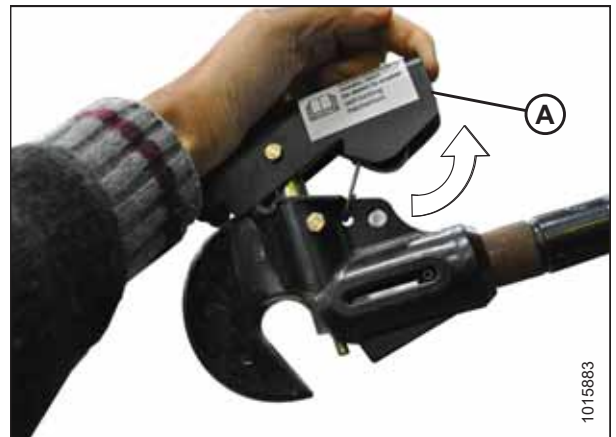

Figure 4.122: Center-Link

18. Disengage the safety props on both lift cylinders as follows:
 - a. Turn lever (A) away from the header to raise the safety prop until the lever locks into the vertical position.
 - b. Repeat for the opposite cylinder.

NOTE:

If the safety prop will **NOT** disengage, raise the header to release the prop.

19. Repeat for the opposite side.

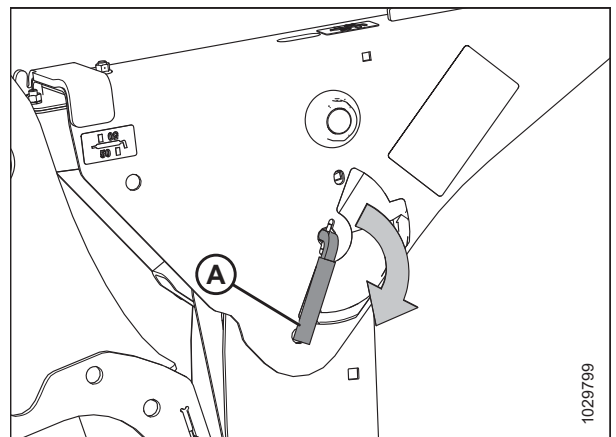

Figure 4.123: Safety Prop Lever

WARNING

Check to be sure all bystanders have cleared the area.

20. Start the engine.
21. Remove header float when prompted by the Harvest Performance Tracker (HPT).

NOTE:

If not prompted by the HPT to remove float, remove float manually. For instructions, refer to *Removing and Restoring Float*, page 224.

22. Lower the header to the ground with HEADER DOWN switch (A).
23. Press HEADER TILT switches (B) as required on GSL to release load on center-link.
24. **Windrowers with self-aligning center-link:**
 - a. Press REEL UP switch (C) to disengage center-link from header.
 - b. Proceed to Step 26, page 174.

25. **Windrowers without self-aligning center-link:**
 - a. Shut off the engine and remove the key.
 - b. Disconnect center-link by lifting release (B) and lift hook (A) off header.

WARNING

Check to be sure all bystanders have cleared the area.

- c. Start the engine.

26. Back windrower away from header.
27. Reinstall pin (A) into header leg, and secure with hairpin (B).

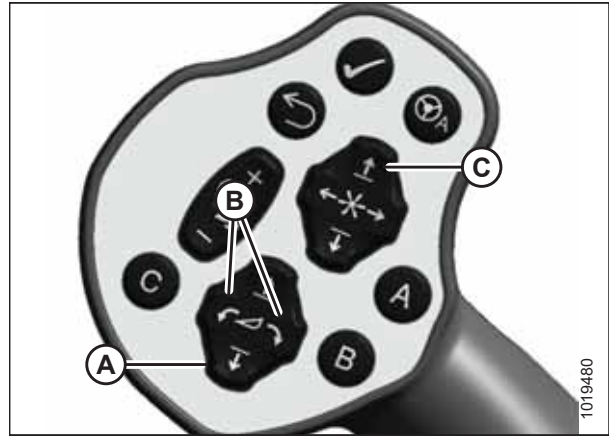

Figure 4.124: GSL

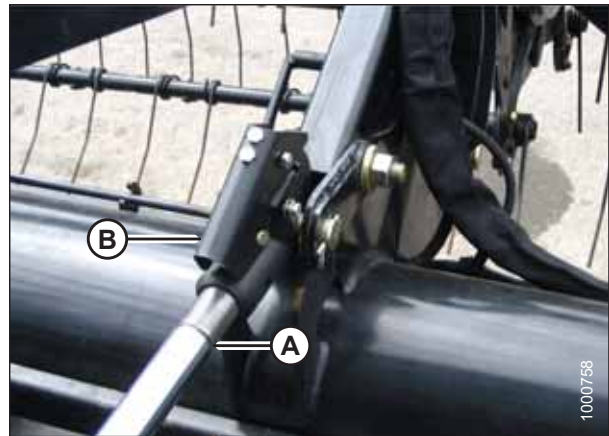

Figure 4.125: Hydraulic Center-Link

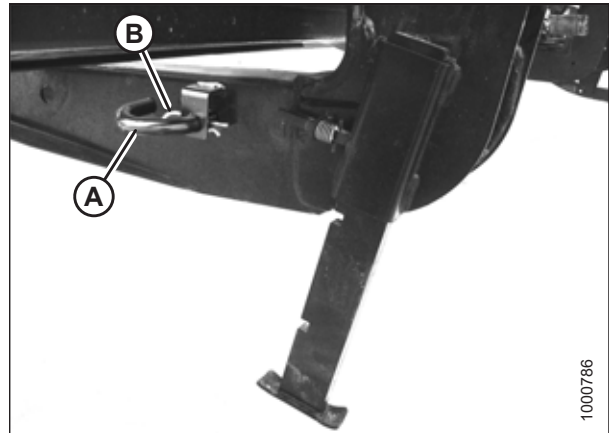

Figure 4.126: Header Stand

4.4.3 R113 or R216 Rotary Disc Header

Attaching R113 or R216 Rotary Disc Header

The windrower may have an optional self-aligning hydraulic center-link that allows vertical position control of the center-link from the cab.

WARNING

To avoid bodily injury or death from unexpected startup of the machine, always stop the engine and remove the key from the ignition before leaving the operator's seat for any reason.

1. Shut down the engine, and remove the key from the ignition.
2. **Hydraulic center-link without self-alignment:** Remove pin (A) and raise center-link (B) until the hook is above the attachment pin on the header. Replace pin (A) to hold center-link in place.

IMPORTANT:

If the center-link is too low, it may contact the header as the windrower approaches the header for hookup.

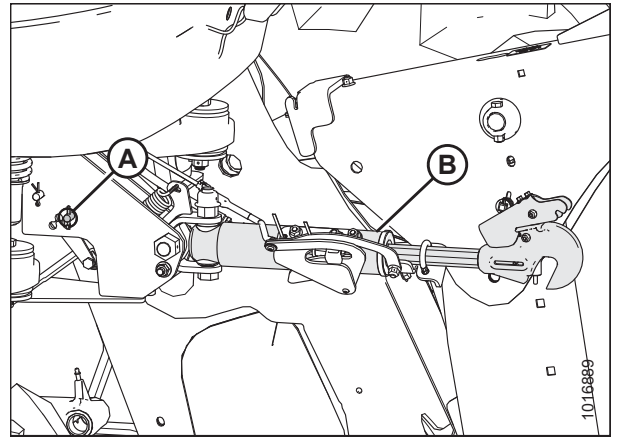

Figure 4.127: Hydraulic Center-Link

OPERATION

3. Remove hairpin (A) from clevis pin (B), and remove the pin from header support (C) on both sides of the header.



WARNING

Check to be sure all bystanders have cleared the area.

4. Start the engine.

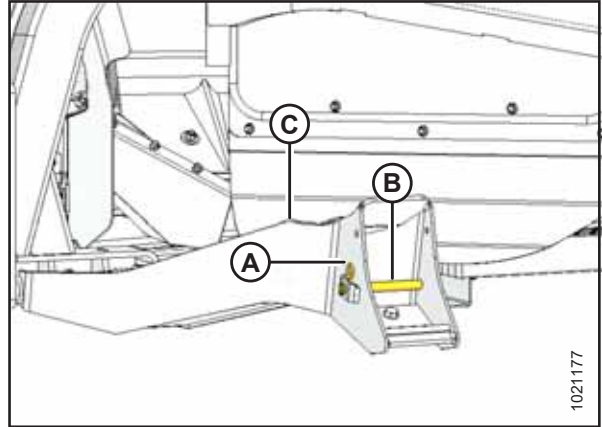

Figure 4.128: Header Support

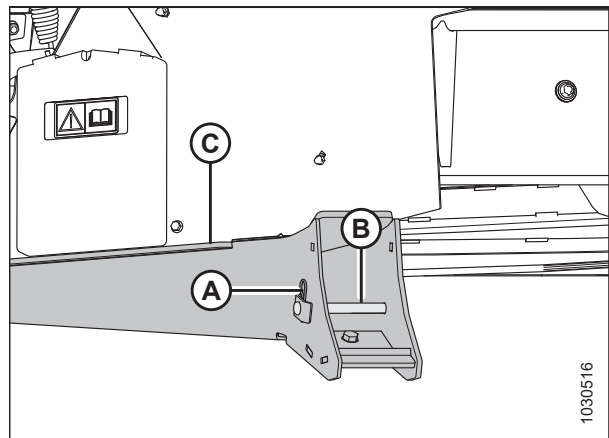

Figure 4.129: Header Support – R216

OPERATION

5. If lowering the header lift legs **WITH** a header or weight box attached, proceed to Step 9, page 178.

If lowering the header lift legs **WITHOUT** a header or weight box attached to the windrower, fully release the tension in header float springs (A):

- If prompted by the Harvest Performance Tracker (HPT) to remove the float, then remove the float and proceed to Step 6, page 177.
- If not prompted by the HPT to remove the float, then proceed to Step 6, page 177 to remove the float manually.

IMPORTANT:

When lowering the header lift legs without a header or weight box attached to the windrower, ensure the float springs tension is fully released to prevent damage to the header lift linkages.

6. Press rotary scroll knob (A) on HPT to highlight the QuickMenu options.
7. Rotate scroll knob (A) to highlight HEADER FLOAT symbol (B), and press the scroll knob to select. The Float Adjust page displays.

8. Press soft key 3 (A) to remove the header float.

NOTE:

If the header float is active, the icon at soft key 3 will display Remove Float; if header float has been removed, the icon will display Resume Float.

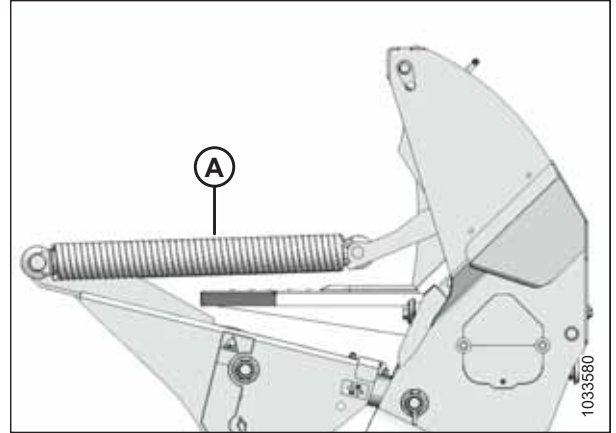

Figure 4.130: Header Float Springs



Figure 4.131: HPT Display



Figure 4.132: HPT Display

OPERATION

9. Press HEADER DOWN switch (E) on the ground speed lever (GSL) to fully retract the header lift cylinders.
10. **Self-aligning hydraulic center-link:** Press REEL UP switch (B) on the GSL to raise the center-link until the hook is above the attachment pin on the header.

IMPORTANT:

If the center-link is too low, it may contact the header as the windrower approaches the header for hookup.

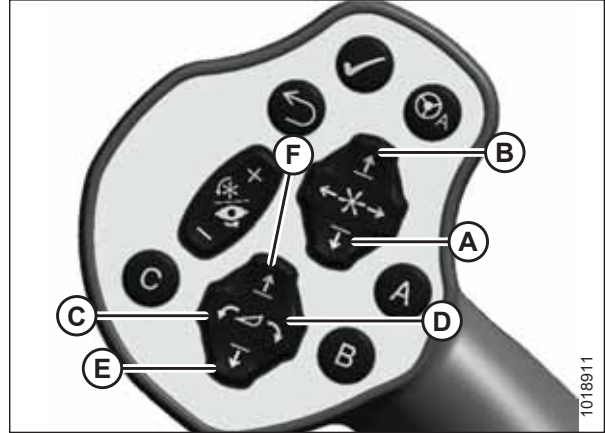

Figure 4.133: GSL

- | | |
|----------------------|--------------------|
| A - Reel Down | B - Reel Up |
| C - Header Tilt Down | D - Header Tilt Up |
| E - Header Down | F - Header Up |

11. Drive the windrower slowly forward until feet (A) enter supports (B). Continue to drive slowly forward until the feet engage the supports and the header nudges forward.
12. Ensure feet (A) are properly engaged in supports (B).

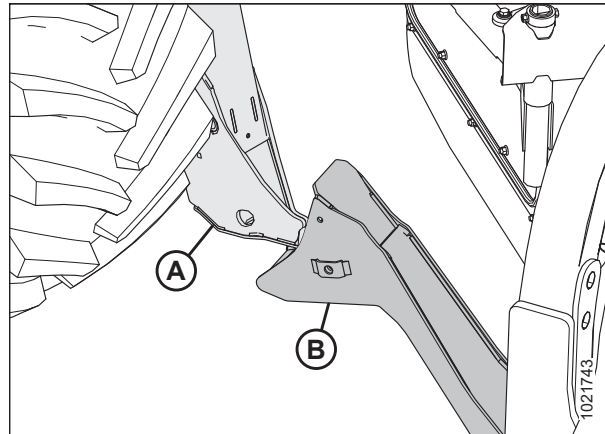

Figure 4.134: Header Support

13. Self-aligning hydraulic center-link:

- a. Adjust the position of center-link cylinder (A) with the switches on the GSL until hook (B) is above the header attachment pin.

IMPORTANT:

Hook release (C) must be down to enable the self-locking mechanism.

- b. If hook release (C) is open (up), shut down the engine, and remove the key from the ignition. Manually push hook release (C) down after the hook engages the header pin.
- c. Lower center-link (A) onto the header with REEL DOWN switch on the GSL until the center-link locks into position and hook release (C) is down.
- d. Check that center-link is locked onto header by pressing the REEL UP switch on the GSL.

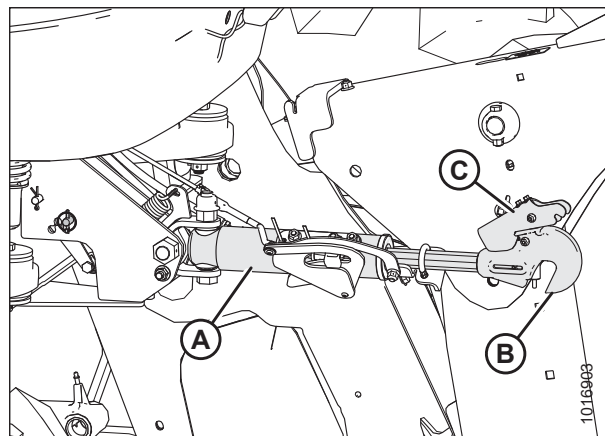

Figure 4.135: Hydraulic Center-Link

OPERATION

14. Hydraulic center-link without self-alignment:

- a. Press the HEADER TILT UP or HEADER TILT DOWN cylinder switches on the GSL to extend or retract the center-link cylinder until the hook is aligned with the header attachment pin.
- b. Shut down the engine, and remove the key from the ignition.
- c. Push down on rod end of link cylinder (B) until the hook engages and locks onto the header pin.

IMPORTANT:

The hook release must be down to enable self-locking mechanism. If the hook release is open (up), manually push it down after hook engages pin.

- d. Check that center-link (A) is locked onto the header by pulling upward on rod end (B) of cylinder.

WARNING

Check to be sure all bystanders have cleared the area.

- e. Start the engine.
15. Press HEADER UP switch (A) to raise the header to maximum height.

NOTE:

If one end of the header does **NOT** fully raise, rephase the lift cylinders as follows:

- a. Press and hold HEADER UP switch (A) until both cylinders stop moving.
 - b. Continue to hold the switch for 3–4 seconds. Cylinders are now phased.
16. Shut down the engine, and remove the key from the ignition.

17. Engage the safety props on both lift cylinders as follows:

- a. Pull lever (A) toward you to release, and then rotate toward header to lower the safety prop onto the cylinder.
- b. Repeat for the opposite lift cylinder.

IMPORTANT:

Ensure the safety props engage over the cylinder piston rods. If the safety prop does **NOT** engage properly, raise the header until the safety prop fits over the rod.

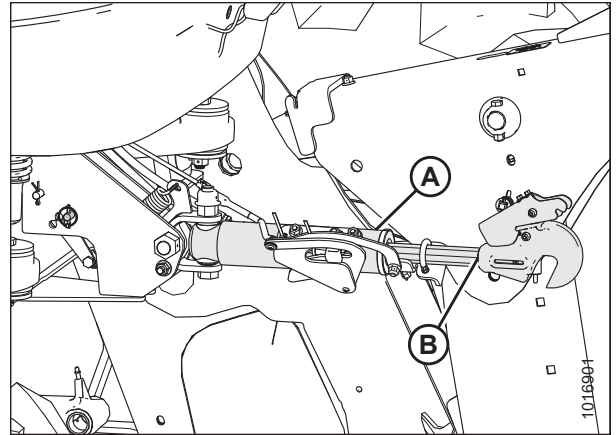

Figure 4.136: Hydraulic Center-Link



Figure 4.137: GSL

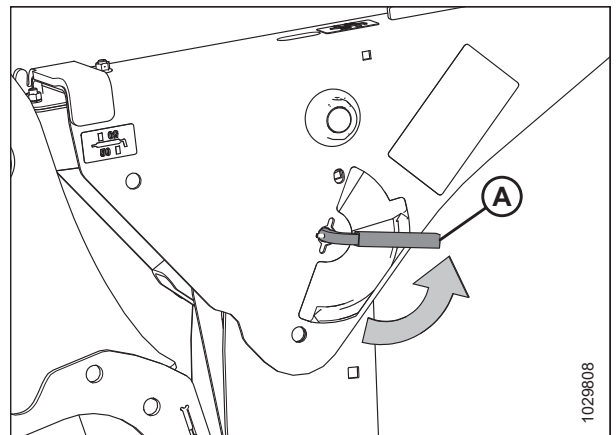

Figure 4.138: Safety Prop Lever

OPERATION

18. Install clevis pin (A) through the support and windrower lift arm and secure with hairpin (B). Repeat for the opposite side of the header.

IMPORTANT:

Ensure clevis pin (A) is fully inserted, and hairpin is installed behind bracket.

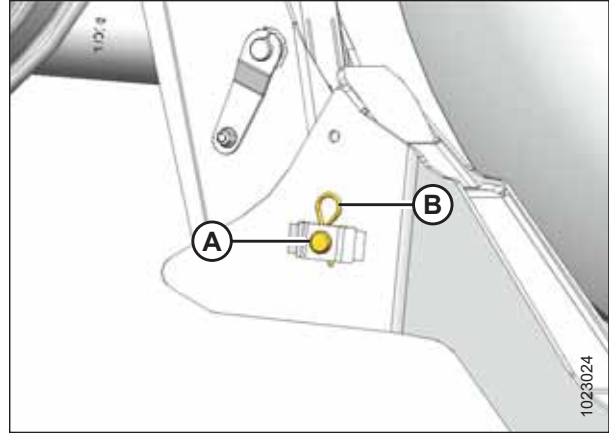

Figure 4.139: Header Support

19. Disengage the safety props on both lift cylinders as follows:
 - a. Turn lever (A) away from the header to raise the safety prop until the lever locks into the vertical position.
 - b. Repeat for the opposite cylinder.

NOTE:

If the safety prop will **NOT** disengage, raise the header to release the prop.

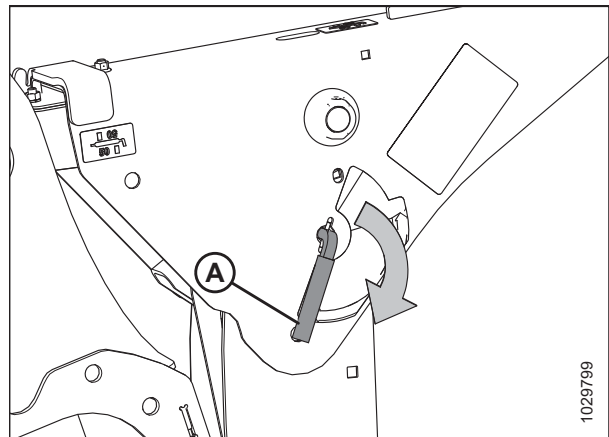

Figure 4.140: Safety Prop Lever

20. Start the engine and press HEADER DOWN switch (A) on GSL to fully lower header.

NOTE:

If not prompted by the HPT display to restore float, restore float manually.

21. Shut down the engine, and remove the key from the ignition.

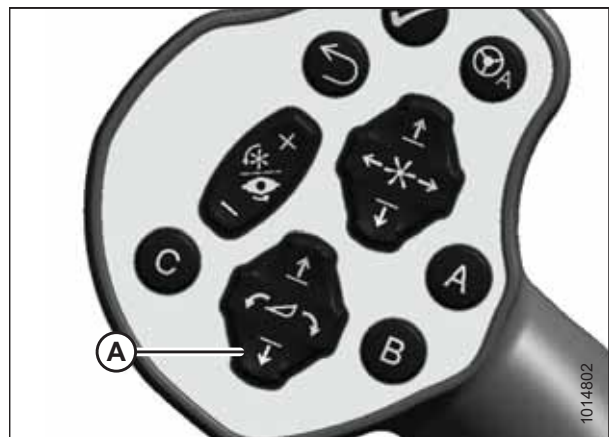

Figure 4.141: GSL

OPERATION

Connecting R113 or R216 Rotary Disc Header Hydraulics

IMPORTANT:

Before connecting the hydraulics from an R113 Rotary Disc Header to an M1240 Windrower, first install the M1240 Low Pressure Case Drain kit (MD #B6698) by following the instructions provided in the kit.

The R113 Rotary Disc Header or R216 Rotary Disc Header hydraulics connection procedure varies depending on the windrower configuration:

- Draper header ready windrowers include one set of hydraulic quick couplers which are compatible with the header drive hoses on the R113 Rotary Disc Header or R216 Rotary Disc Header.
- Rotary disc header ready windrowers include hard plumbed hydraulics connections.

IMPORTANT:

To prevent contamination of the hydraulic system, use a clean rag to remove dirt and moisture from all (fixed and movable) hydraulic couplers.

NOTE:

The R113 Rotary Disc Header hydraulic bundle includes a complete set of quick couplers that can be installed onto a rotary disc header configured windrower.

NOTE:

Quick couplers can be installed if desired on disc-only configured windrowers – two sets of quick coupler bundle B6277 are required to do so.

1. Using a clean rag, remove dirt and moisture from the couplers on the left side of the windrower frame.

OPERATION

- Retrieve hydraulic hoses (A) from the header and route the hose bundle under the windrower frame.

NOTE:

Adding anti-seize to the hose holder pin will make future removal easier.

- Insert pin (B) into hole (C) in windrower frame, and place hose bundle onto support (D).

IMPORTANT:

Route hydraulic hoses as straight as possible, and avoid rub/wear points that could damage the hoses. To prevent damage, hoses should have enough slack to pass by the multicoupler bracket without contact. To adjust hose slack, loosen hose holder (B) on the front windrower leg, adjust hoses, then retighten the hose holder.

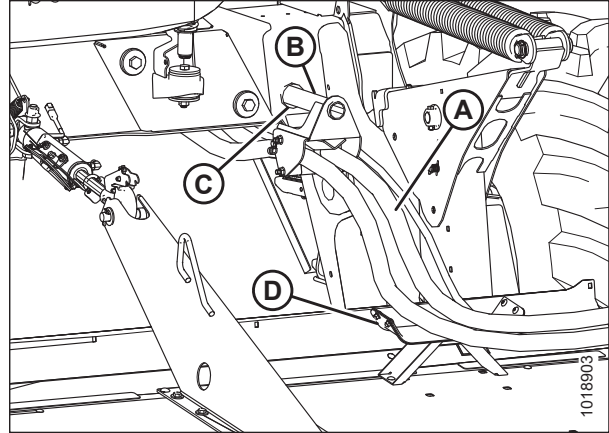

Figure 4.142: R113 Rotary Disc Header Hose Support Attachment

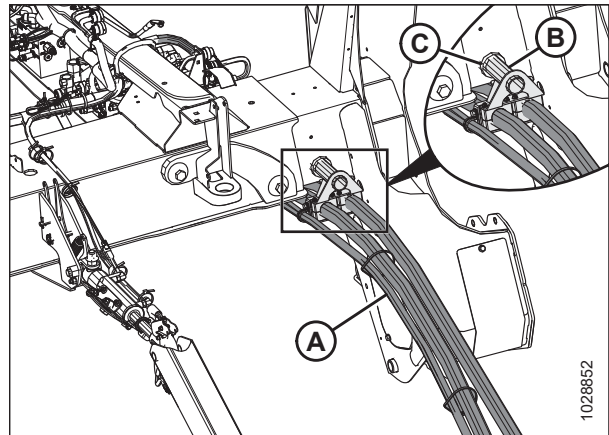

Figure 4.143: R216 Rotary Disc Header Hose Support Attachment

- Remove protective plugs (A) from the ends of the hydraulic hoses.

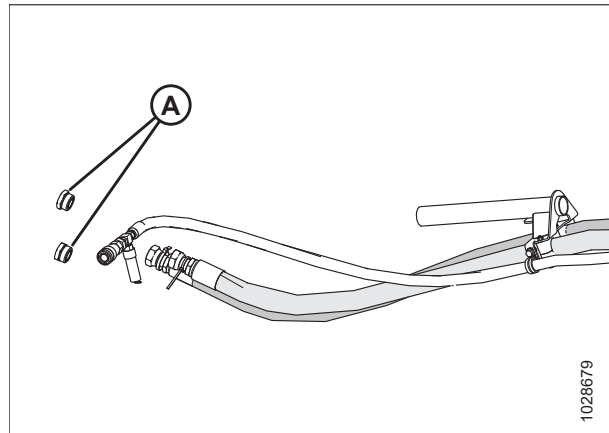

Figure 4.144: Hydraulic Hoses Protective Plugs
– R216 Rotary Disc Header Shown

OPERATION

Proceed with the steps that are relevant to the following windrower configurations:

Windrower Configuration	Steps for Connecting Hydraulics and Electrical
Rotary disc/drapper ready configuration (A)	Steps 5, page 183 to 10, page 185
Rotary disc only hard plumbed configuration (B)	Steps 11, page 185 to 14, page 186
Rotary disc ready configuration (B) with quick couplers installed	Steps 15, page 187 to 22, page 189

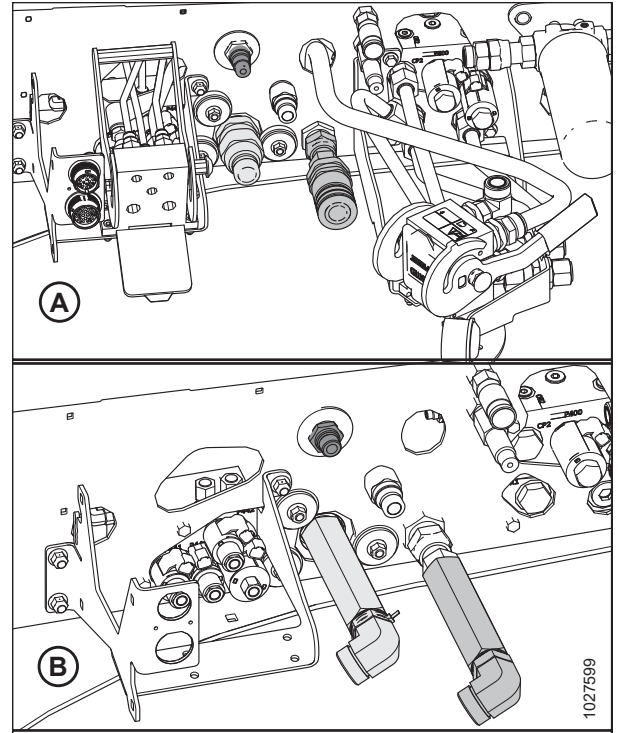

Figure 4.145: Header Hydraulics Configurations

Rotary disc/drapper ready configuration with quick couplers:

5. Ensure hose (A) is disconnected from windrower receptacle (B) and placed in storage cup (C) on multicoupler.

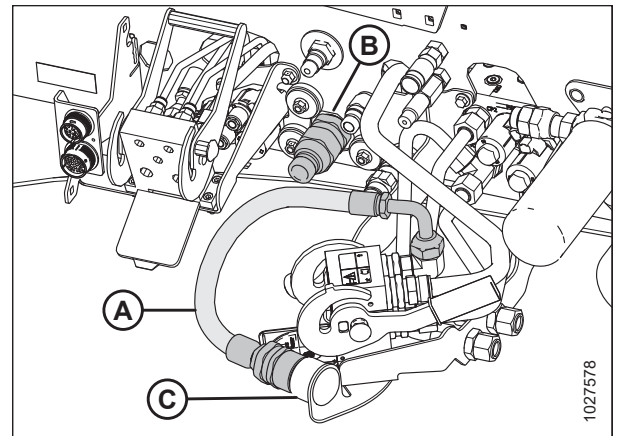

Figure 4.146: Couplers – Draper Ready

OPERATION

6. **For R113 SP Rotary Disc Header:** Remove the extra hydraulic quick couplers from pressure hose (A) and return hose (B) and store them as spares.

NOTE:

It is normal to have an extra set of quick couplers with the rotary disc/draper ready configuration.

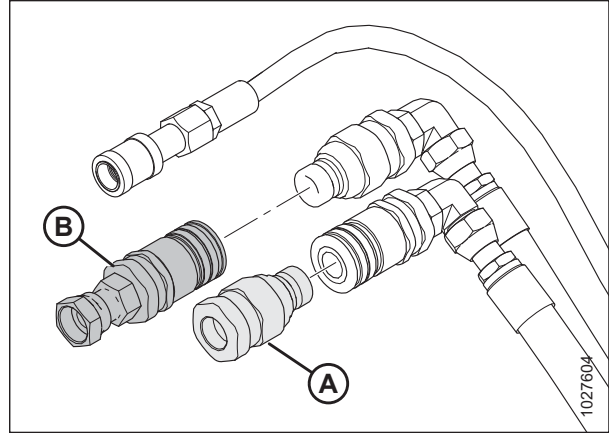

Figure 4.147: Hydraulic Quick Couplers

7. **For R113 Rotary Disc Header:** Connect the hydraulic hoses to the windrower with quick coupler fittings as follows:
- Connect pressure hose female coupler to receptacle (A).
 - Connect return hose male coupler to receptacle (B).
 - Connect case drain hose (C) to mating 1/2 in. coupler on frame—installed with the M1240 Low Pressure Case Drain kit (MD #B6698). The other 1/2 in. flat faced coupler for case drain (E) is **NOT** suitable for the R113 Rotary Disc Header.
 - Connect the electrical harness to receptacle (D).

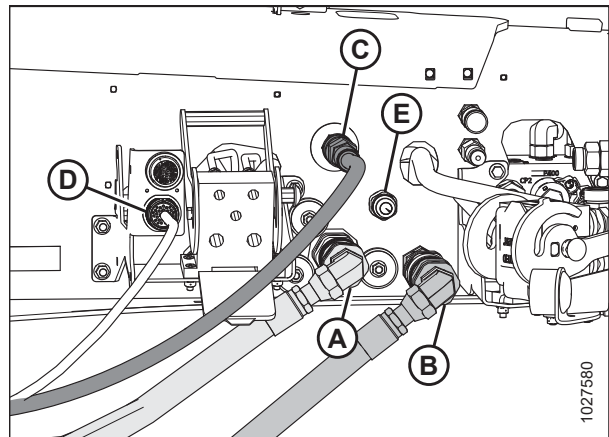

Figure 4.148: R113 SP Rotary Disc Header Hydraulics and Electrical – Draper Ready Windrower

8. **For R216 Rotary Disc Header:** Connect hydraulic fittings to the hydraulic hoses as follows:
- Attach 90° elbow fitting (A) and 1 in. female coupler fitting (B) to disc pressure hose (C).
 - Attach 90° elbow fitting (A) and 1 in. male coupler fitting (D) to disc return hose (E).

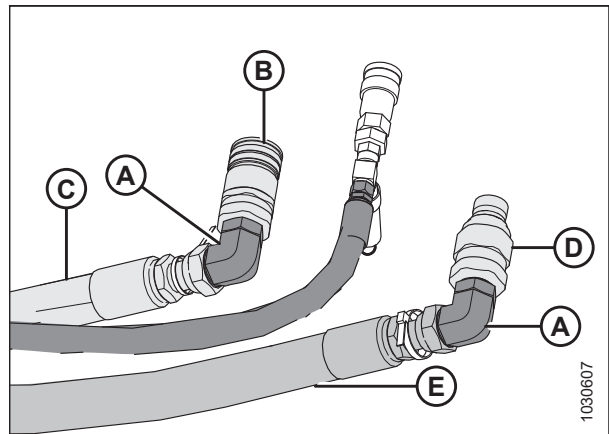

Figure 4.149: R216 Rotary Disc Header Hydraulic Fittings

OPERATION

9. **For R216 Rotary Disc Header:** Connect the hydraulic hoses to the windrower with quick coupler fittings as follows:
 - a. Connect disc pressure hose (A) with coupler (B) and torque to 205–226 Nm (151–167 lbf-ft).
 - b. Connect disc return hose (C) with coupler (D) and torque to 205–226 Nm (151–167 lbf-ft).
 - c. Connect case drain hose (E) to fitting (F), with relief valve pointing towards the ground.

NOTE:

If required, loosen fitting (F) and retighten as needed to ensure relief valve is pointing straight down as shown.

10. To connect an R2 Rotary Disc Header electrical harness, refer to Steps 23, page 189 to 26, page 190.

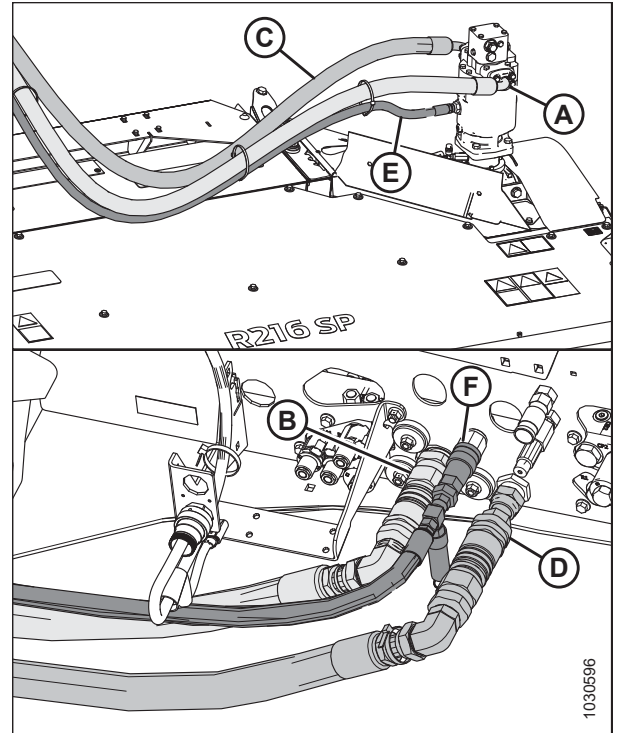

Figure 4.150: R216 Rotary Disc Header Hydraulics and Electrical – Draper Ready

Hard plumbed fittings – rotary disc ready windrower:

11. **For R113 Rotary Disc Header:** If installed, remove the existing quick couplers and elbow fittings from header hydraulic pressure hose (A) and return hose (B). Do **NOT** remove fittings from case drain hose (C).

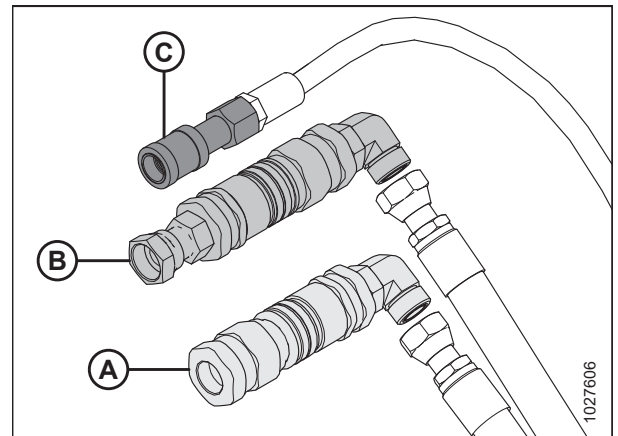

Figure 4.151: R113 SP Hose Bundle – Rotary Disc Ready Windrower

OPERATION

12. **For R113 Rotary Disc Header:** Connect the hydraulic hoses to the windrower with hard plumbed fittings as follows:
- Connect rotary disc pressure hose (A) to fitting on frame and torque to 205–226 Nm (151–167 lbf-ft).
 - Connect rotary disc return hose (B) to fitting on frame and torque to 205–226 Nm (151–167 lbf-ft).
 - Connect case drain hose (C) to mating 1/2 in. coupler on frame—installed with the M1240 Low Pressure Case Drain kit (MD #B6698). The other 1/2 in. flat faced coupler for case drain (E) is **NOT** suitable for the R113 Rotary Disc Header.
 - Connect the electrical harness to receptacle (D).

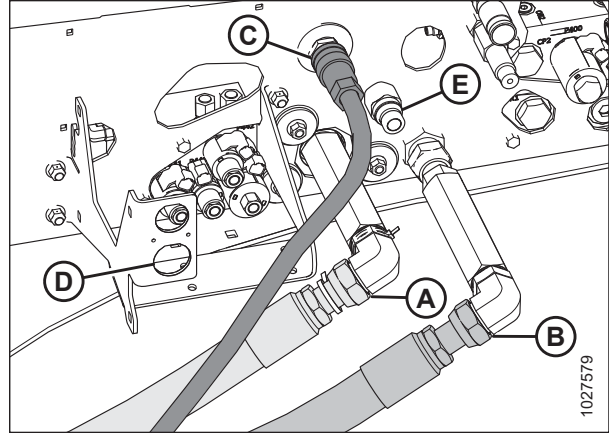

Figure 4.152: Hard Plumbed Connections on Disc Header Ready Windrower

13. **For R216 Rotary Disc Header:** Connect the hydraulic hoses to the windrower with hard plumbed fittings as follows:
- Connect disc pressure hose (A) marked with a red cable tie (B) to hard plumb fitting marked with a red cable tie (C) and torque to 205–226 Nm (151–167 lbf-ft).
 - Connect disc return hose (D) to hard plumb fitting (E) and torque to 205–226 Nm (151–167 lbf-ft).
 - Connect case drain hose (F) to fitting (G).
14. To connect an R2 Rotary Disc Header electrical harness, refer to Steps 23, page 189 to 26, page 190.

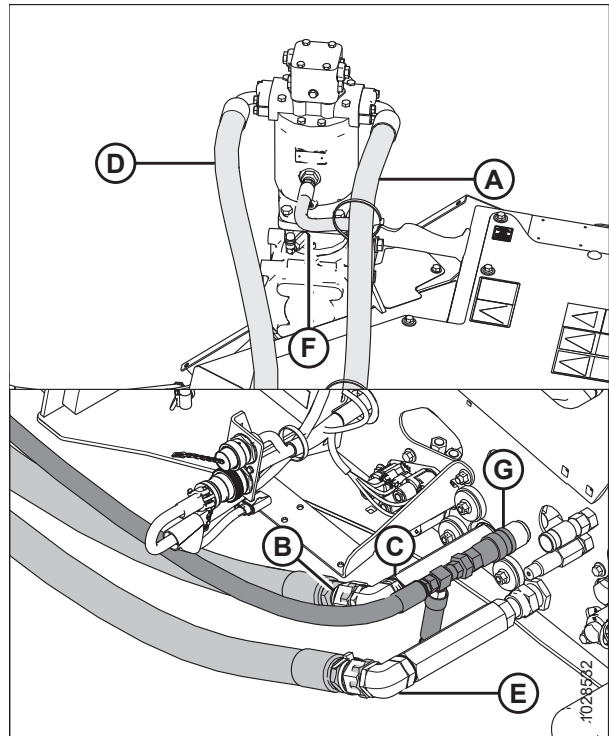

Figure 4.153: Hard Plumbed Connections on R216 Rotary Disc Header Ready Windrower

OPERATION

Quick coupler fittings – rotary disc ready windrower:

15. **For R113 Rotary Disc Header:** Remove quick couplers from pressure hose (A) and return hose (B) on the R113 Rotary Disc Header hydraulic hose bundle.

NOTE:

Do **NOT** remove the fittings on the case drain hose that was installed with the M1240 Low Pressure Case Drain kit (MD #B6698).

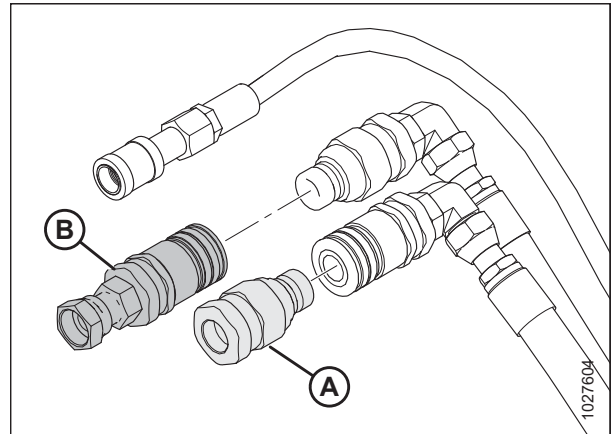

Figure 4.154: R113 Rotary Disc Header Hydraulic Quick Couplers

16. **For R216 Rotary Disc Header:** Connect hydraulic fittings to the hydraulic hoses as follows:

- Attach 90° elbow fitting (A) and 1 in. female coupler fitting (B) to disc pressure hose (C).
- Attach 90° elbow fitting (A) and 1 in. male coupler fitting (D) to disc return hose (E).

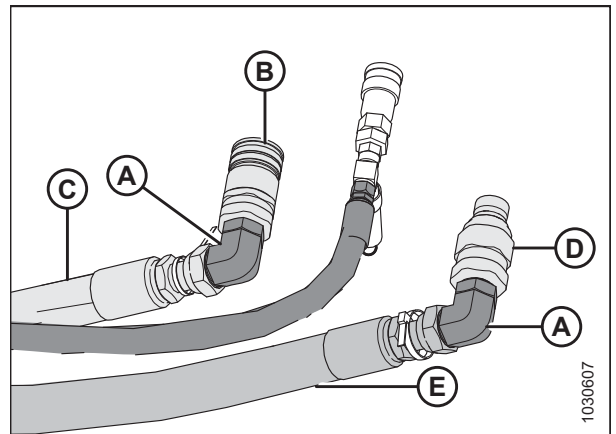

Figure 4.155: R216 Rotary Disc Header Hydraulic Fittings

17. Remove the extension fittings and elbows (A) from the rotary disc header hydraulic pressure and return connections.

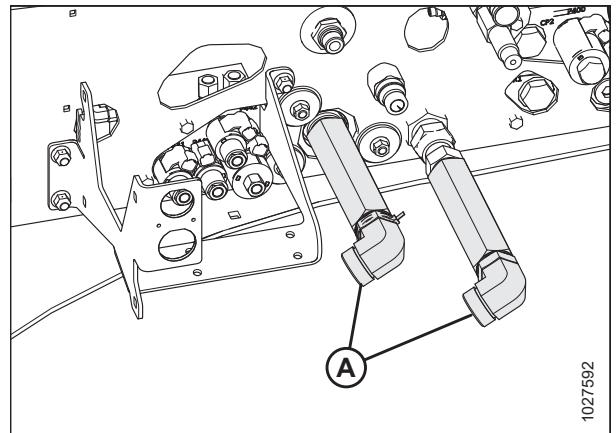

Figure 4.156: Hard Plumbed Connections – Rotary Disc Ready Windrower

OPERATION

18. Install the male quick coupler at windrower pressure receptacle (A).
19. Install the female quick coupler with adapter at windrower return receptacle (B).

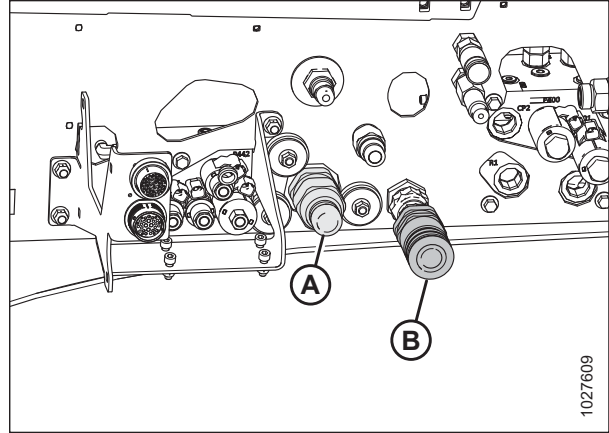

Figure 4.157: Quick Couplers on Rotary Disc Ready Windrower

20. **For R113 Rotary Disc Header:** Connect the hydraulic hoses to the windrower with quick connect fittings, as follows:
 - a. Connect pressure hose (A) female coupler to receptacle.
 - b. Connect return hose (B) male coupler to receptacle.
 - c. Connect case drain hose (C) to mating 1/2 in. coupler on frame—installed with the M1240 Low Pressure Case Drain kit (MD #B6698). The other 1/2 in. flat faced coupler for case drain (E) is **NOT** suitable for the R113 Rotary Disc Header.
 - d. Connect the electrical harness to receptacle (D).

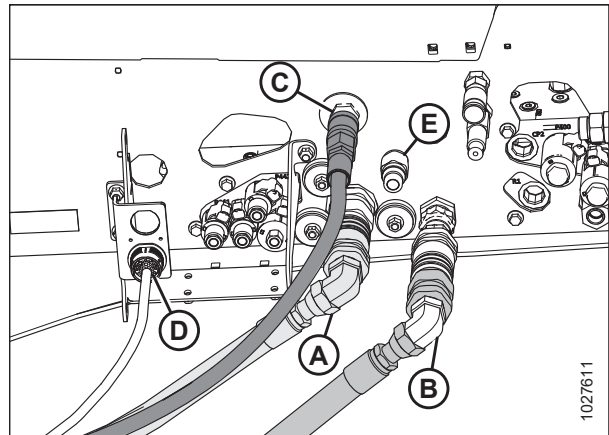

Figure 4.158: Quick Couplers on Rotary Disc Ready Windrower

OPERATION

21. **For R216 Rotary Disc Header:** Connect the hydraulic hoses to the windrower with quick coupler fittings as follows:
- Connect disc pressure hose (A) with coupler (B) and torque to 205–226 Nm (151–167 lbf·ft).
 - Connect disc return hose (C) with coupler (D) and torque to 205–226 Nm (151–167 lbf·ft).
 - Connect case drain hose (E) to fitting (F), with relief valve pointing towards the ground.

NOTE:

If required, loosen fitting (F) and retighten as needed to ensure relief valve is pointing straight down as shown.

22. To connect an R2 Rotary Disc Header electrical harness, refer to Steps 23, page 189 to 26, page 190.

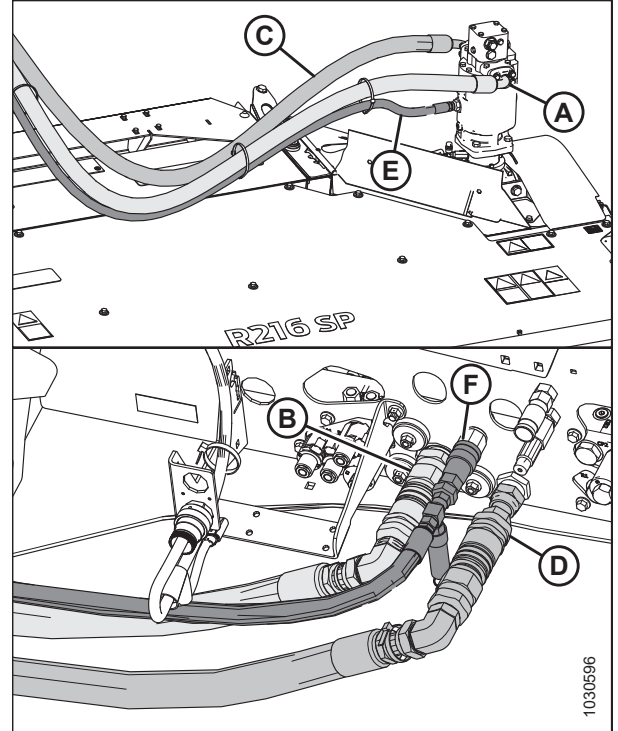

Figure 4.159: R216 Rotary Disc Header Hydraulic Connections

To connect electrical harness between R2 Rotary Disc Header and M1240 windrower, follow these steps:

23. Free electrical harness (A) from adjustable strap (B).

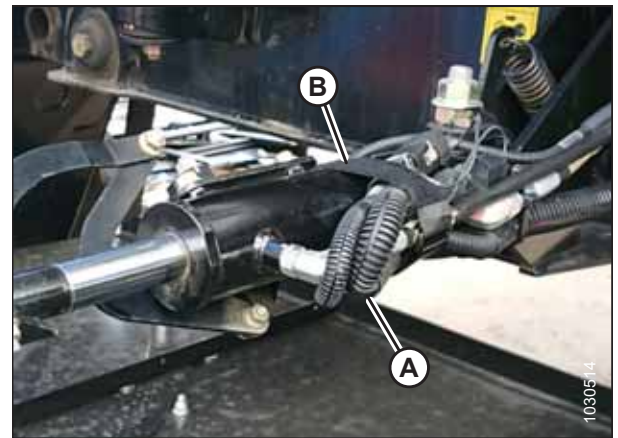

Figure 4.160: Electrical Harness Secured to Center-Link

OPERATION

24. Connect main header harness (A) to adapter harness (B).
25. Connect electric baffle control harness (C) to adapter harness (D) if installed.

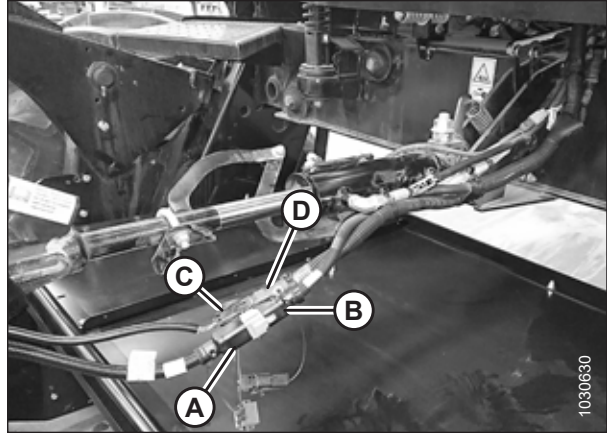

Figure 4.161: Electrical Harness Connection at Center-Link

26. Check electrical connection (A) at the windrower.

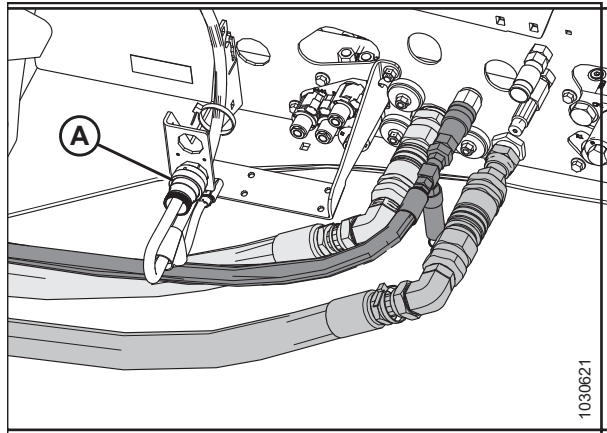

Figure 4.162: Electrical Connection at Windrower

Detaching R113 Rotary Disc Header

WARNING

To avoid bodily injury or death from unexpected startup of the machine, always stop the engine and remove the key from the ignition before leaving the operator's seat for any reason.

WARNING

Check to be sure all bystanders have cleared the area.

1. Start the engine.
2. Press switch (A) to raise the header to the maximum height.
3. Shut down the engine, and remove the key from the ignition.



Figure 4.163: GSL

4. Engage the safety props on both lift cylinders as follows:
 - a. Pull lever (A) toward you to release, and then rotate toward header to lower the safety prop onto the cylinder.
 - b. Repeat for the opposite lift cylinder.

IMPORTANT:

Ensure the safety props engage over the cylinder piston rods. If the safety prop does **NOT** engage properly, raise the header until the safety prop fits over the rod.

5. Open the platform. For instructions, refer to [5.4.1 Opening Platform, page 304](#).

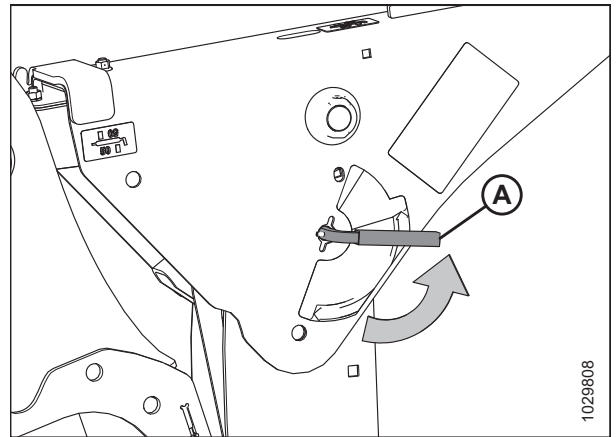

Figure 4.164: Safety Prop Lever

OPERATION

6. **For R113 SP:** Disconnect electrical harness (A) and hydraulic hoses (B), (C), and (D) from the windrower.

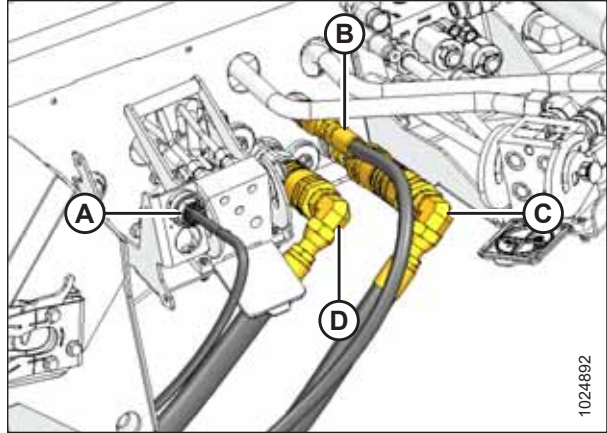

Figure 4.165: For R113 SP Header Drive Hydraulics

7. Remove hose support (A) and the hose bundle from the windrower frame.

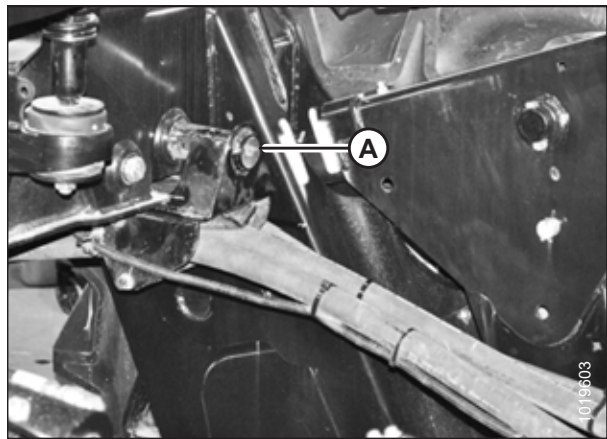

Figure 4.166: R113 SP Hoses on Windrower

8. **R113 SP:** Slide support (A) into center-link support (B) and secure with hardware (C).

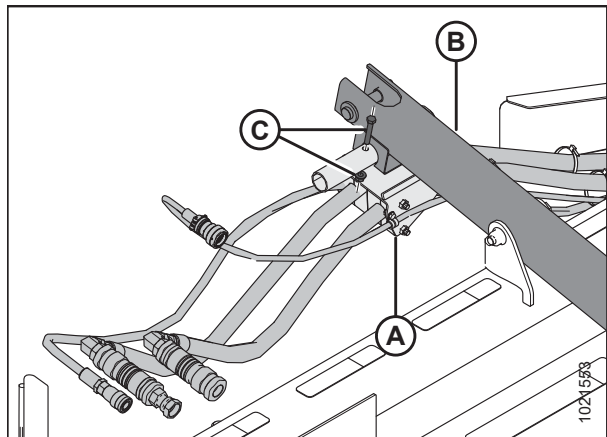

Figure 4.167: R113 SP Hose Storage Position

OPERATION

9. **R113 SP:** Store hoses (A) and electrical harness (B) disconnected from the windrower in Step 6, page 192 into storage plate (C).

NOTE:

Install caps and plugs on open lines to prevent buildup of dirt and debris while in storage.

NOTE:

Some parts removed from the illustration for clarity.

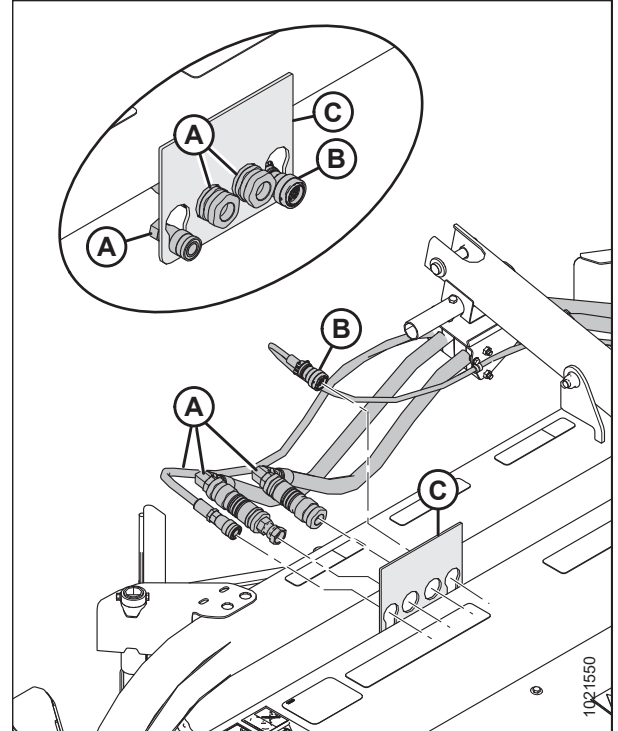

Figure 4.168: R113 SP Hydraulic Storage Plate

10. Remove hairpin (B) from clevis pin (A). Remove clevis pin from header support (C) on both sides of the header.

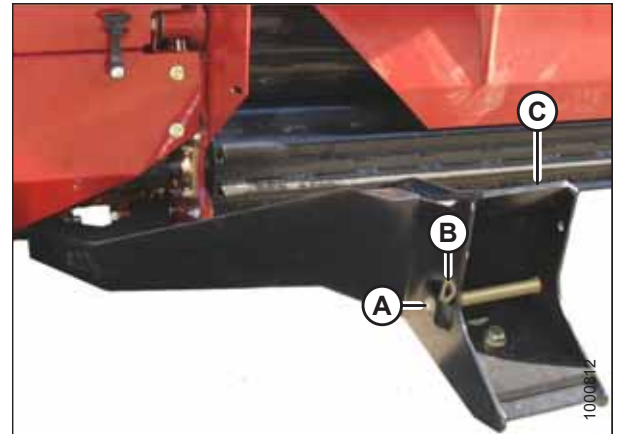

Figure 4.169: Header Supports

OPERATION

11. **Windrowers WITH center-link self-alignment kit:** Release center-link latch (A) before returning to the cab.

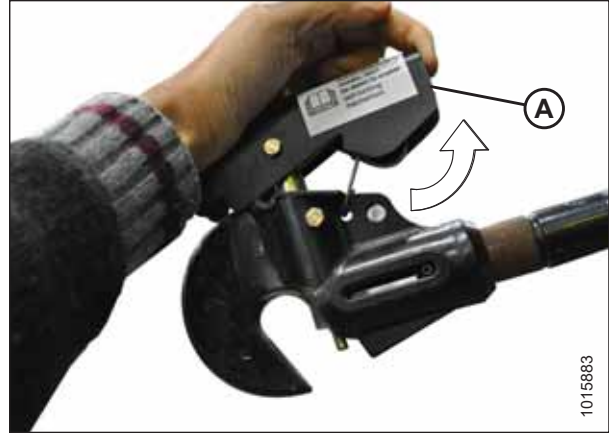

Figure 4.170: Center-Link

12. Disengage the safety props on both lift cylinders as follows:
 - a. Turn lever (A) away from the header to raise the safety prop until the lever locks into the vertical position.
 - b. Repeat for the opposite cylinder.

NOTE:

If the safety prop will **NOT** disengage, raise the header to release the prop.

13. Repeat for the opposite side.

WARNING

Check to be sure all bystanders have cleared the area.

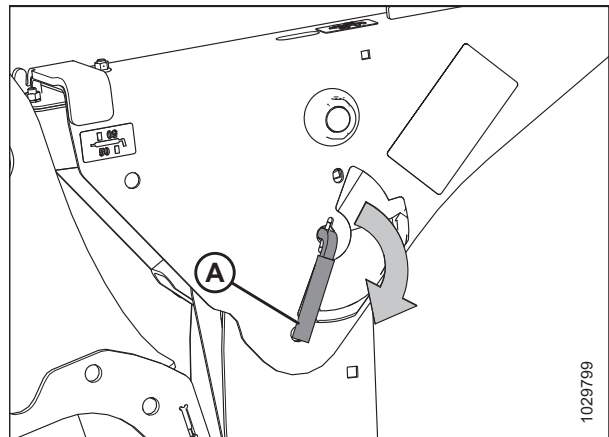

Figure 4.171: Safety Prop Lever

14. Start the engine.
15. Remove header float when prompted by the Harvest Performance Tracker (HPT).

NOTE:

If not prompted by the HPT to remove float, remove float manually.

16. Lower the header fully.
17. Use HEADER TILT cylinder switches (A) on the GSL to release the load on the center-link cylinder.
18. **Windrowers WITH center-link self-alignment kit:** Operate the link lift cylinder with REEL UP switch (B) to disengage the center-link from the header. Proceed to step 22, page 195.

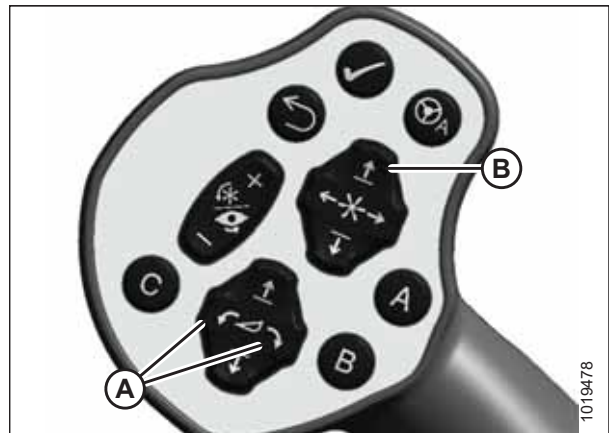

Figure 4.172: GSL

OPERATION

19. **Windrowers WITHOUT center-link self-alignment kit:** Shut down the engine, and remove the key from the ignition.
20. **Windrowers WITHOUT center-link self-alignment kit:** Lift hook release (A) and lift hook (B) off header pin.

WARNING

Check to be sure all bystanders have cleared the area.

21. **Windrowers WITHOUT center-link self-alignment kit:** Start the engine.

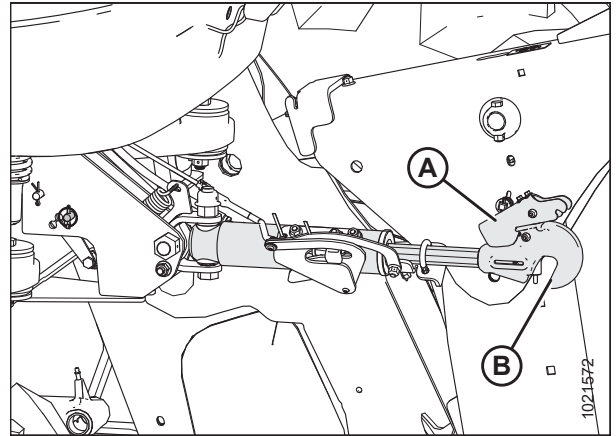

Figure 4.173: Hydraulic Center-Link

22. Back the windrower slowly away from the header.
23. Reinstall clevis pin (A) through support (C) and secure with hairpin (B). Repeat for opposite side.

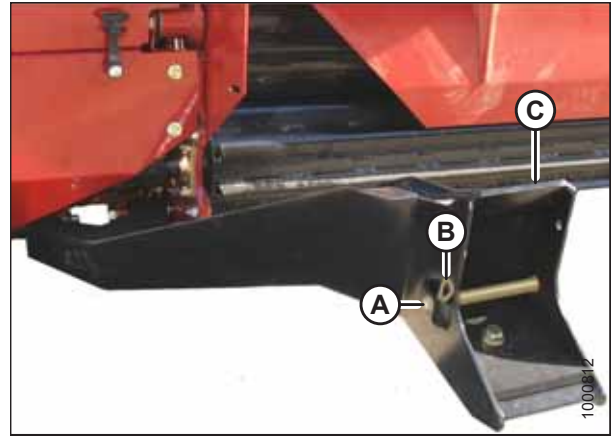

Figure 4.174: Header Support

OPERATION

Detaching R216 Rotary Disc Header

WARNING

To avoid bodily injury or death from unexpected startup of the machine, always stop the engine and remove the key from the ignition before leaving the operator's seat for any reason.

WARNING

Check to be sure all bystanders have cleared the area.

1. Start the engine, and press switch (A) to lower the header to the ground.
2. Shut down the engine, and remove the key from the ignition.
3. Open the left platform. For instructions, refer to the windrower operator's manual.



Figure 4.175: GSL

4. **For R216 SP:** Disconnect hydraulic hoses (A), (B), and (C) from the windrower.
5. **For R216 SP:** Install caps and plugs on open lines to prevent buildup of dirt and debris while in storage.

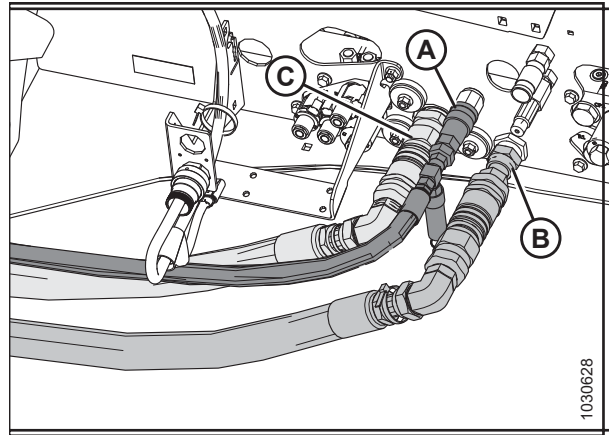

Figure 4.176: For R216 SP Header Drive Hydraulics

OPERATION

6. Remove hose support (A) and hose bundle from windrower frame.

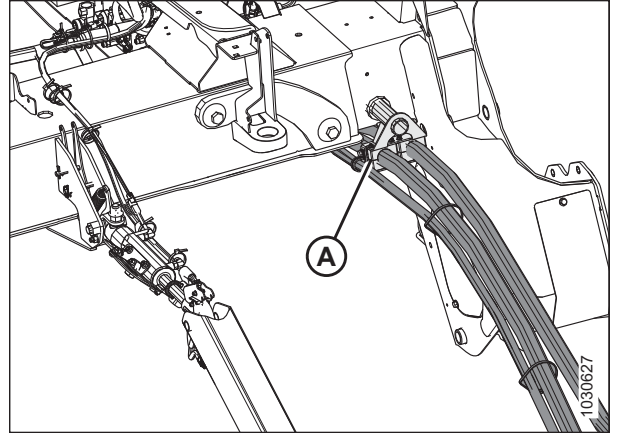

Figure 4.177: R216 SP Hoses on Windrower

7. **R216 SP:** Rest hydraulic hose bundle (A) on header for storage as shown.

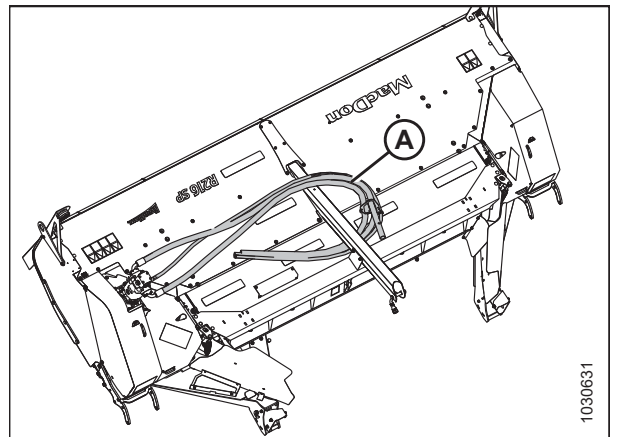

Figure 4.178: R216 SP Hose Bundle Storage Position

8. **R216 SP:** Disconnect main header harness (A) from adapter harness (B).
9. **R216 SP:** Disconnect electric baffle control harness (C) from adapter harness (D) if installed.

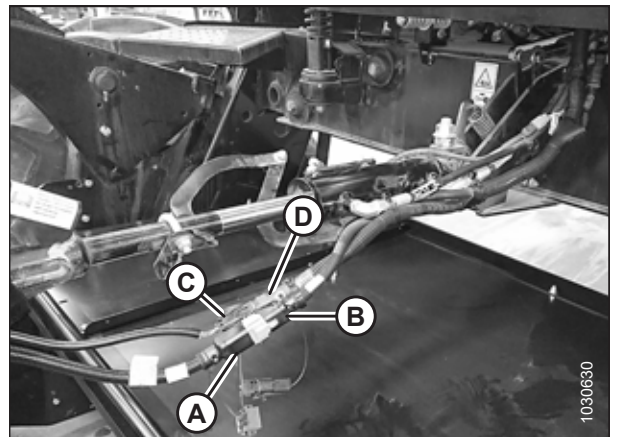

Figure 4.179: R216 SP Electrical Connection

OPERATION

10. **R216 SP:** Secure adapter harness (A) on the center link with an adjustable strap (B).

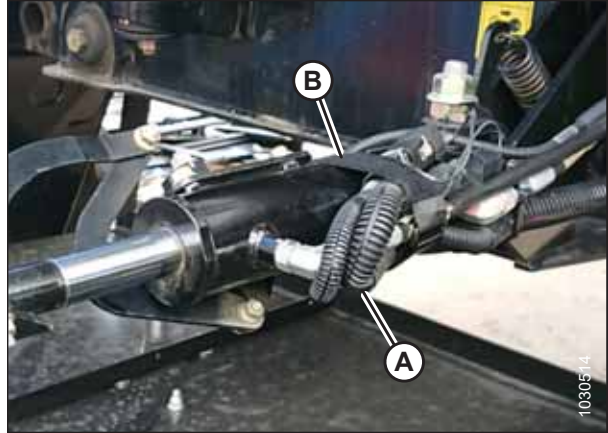

Figure 4.180: R1216 SP Adapter Harness

11. Remove hairpin (B) from clevis pin (A). Remove clevis pin from header support (C) on both sides of header.

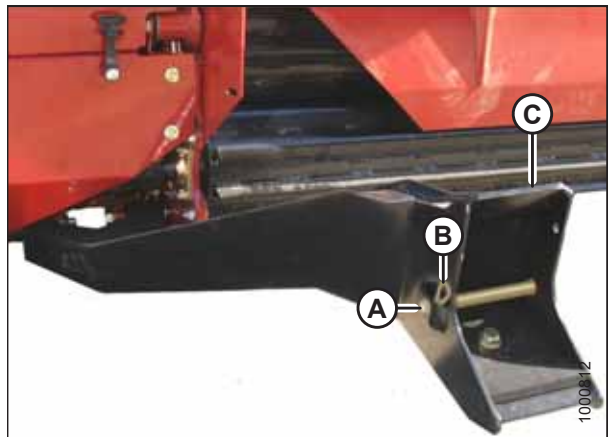

Figure 4.181: Header Supports

Windrowers with center-link self-alignment kit only:

12. Release center-link latch (A) before returning to the cab.

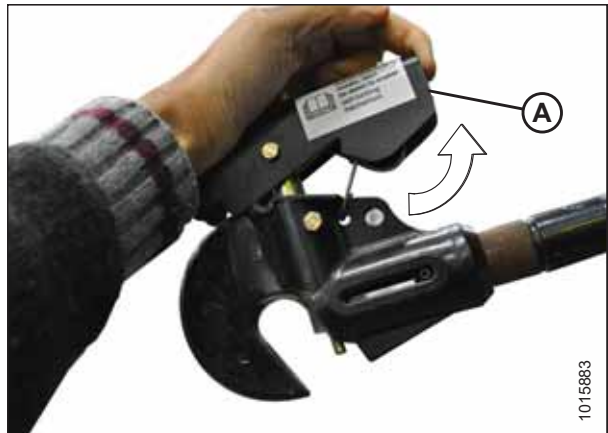

Figure 4.182: Center-Link

WARNING

Check to be sure all bystanders have cleared the area.

13. Start the engine.
14. Remove header float when prompted by the Harvest Performance Tracker (HPT).

NOTE:

If not prompted by the HPT to remove float, remove float manually.

Self-aligning center-link (if installed):

15. Use HEADER TILT cylinder switches (A) on GSL to release load on center-link cylinder.
16. Operate the link lift cylinder with REEL UP switch (B) to disengage the center-link from the header.

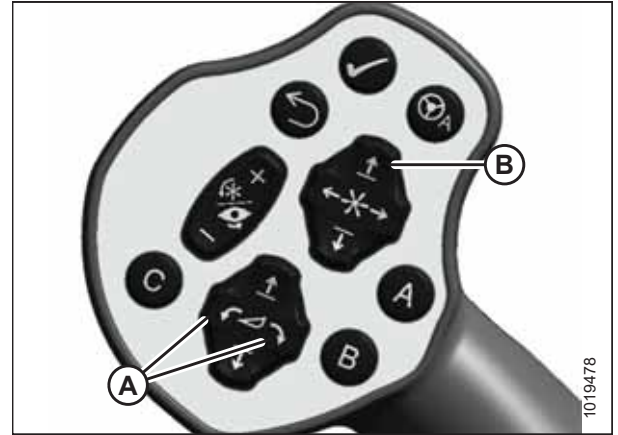

Figure 4.183: GSL

Non-self-aligning center-link:

17. Shut down the engine, and remove the key from the ignition.
18. Lift hook release (A) and lift hook (B) off header pin.

WARNING

Check to be sure all bystanders have cleared the area.

19. Start the engine.

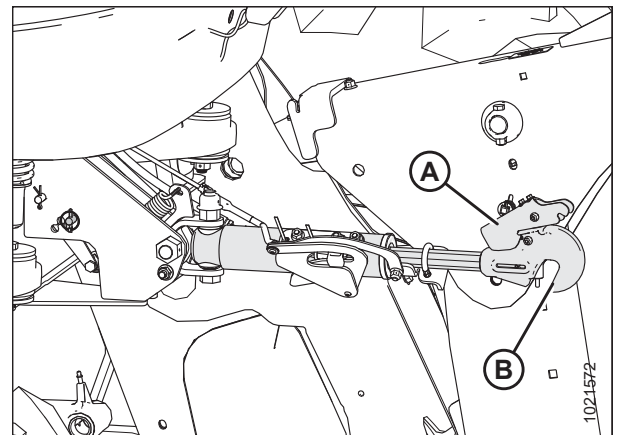

Figure 4.184: Hydraulic Center-Link

OPERATION

20. Back the windrower slowly away from header.
21. Reinstall clevis pin (A) through support (C) and secure with hairpin (B). Repeat for opposite side.

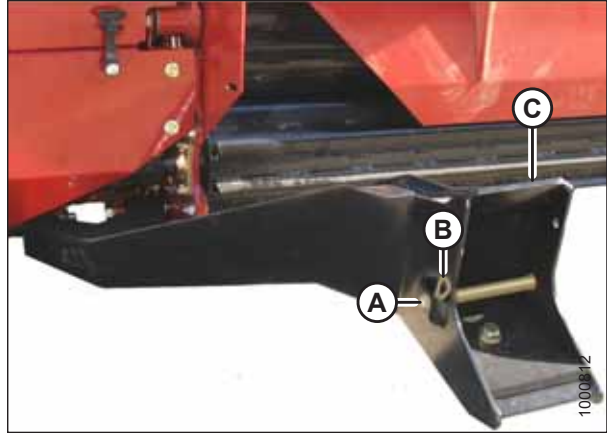

Figure 4.185: Header Support

4.4.4 R85 4.9 m (16 ft.) Rotary Disc Header

Attaching an R85 4.9 m (16 ft.) Rotary Disc Header

To attach an R85 Rotary Disc Header to a windrower, follow these steps:

WARNING

To avoid bodily injury or death from unexpected startup of the machine, always stop the engine and remove the key from the ignition before leaving the operator's seat for any reason.

1. Remove hairpin (B) from clevis pin (A), and remove pin from header support (C) on both sides of header.

WARNING

Check to be sure all bystanders have cleared the area.

2. Start engine.

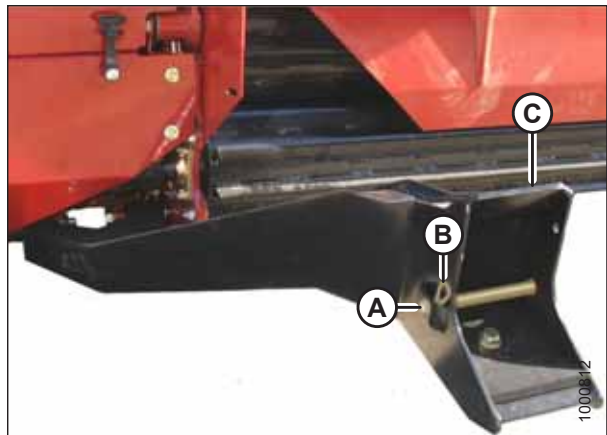

Figure 4.186: Header Support

OPERATION

IMPORTANT:

When lowering header lift legs without a header or weight box attached to the windrower, ensure the float springs (A) tension is fully released to prevent damage to the header lift linkages.

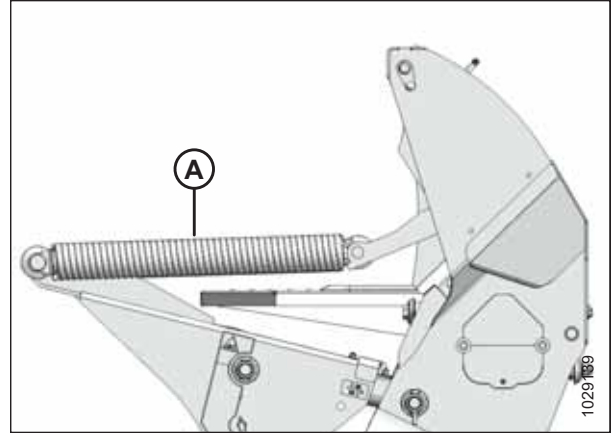

Figure 4.187: Header Float Spring

If not prompted by the harvest performance tracker (HPT) display to remove float, remove float manually by doing the following:

3. Press rotary scroll knob (A) on the Harvest Performance Tracker (HPT) to highlight the QuickMenu options.
4. Rotate scroll knob (A) to highlight HEADER FLOAT symbol (B), and press the scroll knob to select.



Figure 4.188: HPT Display

5. On the FLOAT ADJUST page, press soft key 3 (A) to remove the header float.

NOTE:

If the header float is active, the icon at soft key 3 will say REMOVE FLOAT; if header float has been removed, the icon will say RESUME FLOAT.



Figure 4.189: HPT Display

OPERATION

- Press HEADER DOWN switch (E) on the ground speed lever (GSL) to fully retract header lift cylinders.
- Press REEL UP switch (B) on the GSL to raise the center-link until the hook is above the attachment pin on the header.

IMPORTANT:

If the center-link is too low, it may contact the header as the windrower approaches the header for hookup.

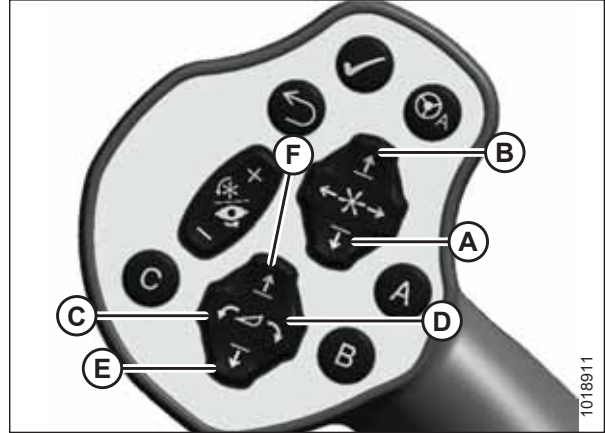

Figure 4.190: GSL

A - Reel Down	B - Reel Up
C - Header Tilt Down	D - Header Tilt Up
E - Header Down	F - Header Up

- Slowly drive the windrower forward until windrower feet (A) enter header supports (B). Continue to drive slowly forward until feet engage the supports and header nudges forward.
- Ensure that lift linkages are properly engaged in header legs.

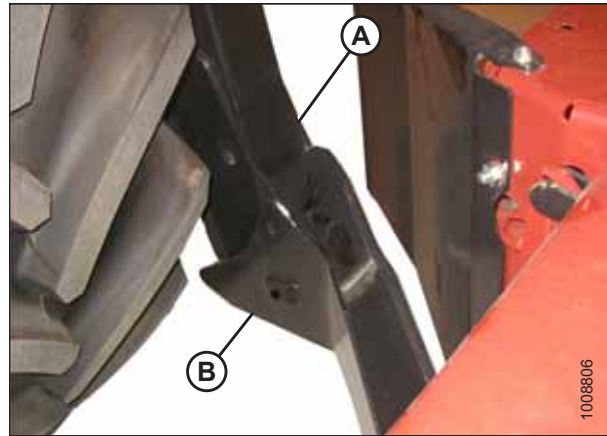

Figure 4.191: Header Support

- Adjust position of center-link cylinder (A) with the switches on the GSL until hook (B) is above the header attachment pin.

IMPORTANT:

Hook release (C) must be down to enable the self-locking mechanism. If the release is open (up), manually push it down after the hook engages the header pin.

- Lower center-link (A) onto the header with REEL DOWN switch on GSL until it locks into position (hook release [C] is down). Refer to Figure 4.190, page 202 for GSL controls.
- Check that the center-link is locked onto header by pressing the REEL UP switch on the GSL. Refer to Figure 4.190, page 202 for GSL controls.

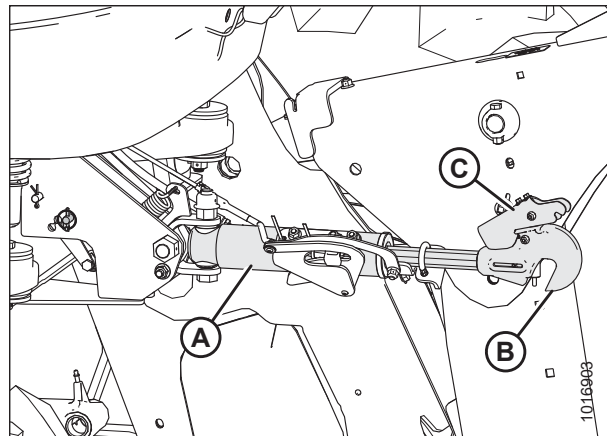

Figure 4.192: Center-Link

WARNING

Check to be sure all bystanders have cleared the area.

- Start engine.

OPERATION

14. Press HEADER UP switch (A) to raise header to maximum height.
15. If one end of the header does **NOT** fully raise, rephase the lift cylinders as follows:
 - a. Press and hold HEADER UP switch (A) until both cylinders stop moving.
 - b. Continue to hold the switch for 3–4 seconds. Cylinders are now phased.
16. Shut down the engine, and remove the key from the ignition.



Figure 4.193: GSL

17. Engage the safety props on both lift cylinders as follows:
 - a. Pull lever (A) toward you to release, and then rotate toward header to lower the safety prop onto the cylinder.
 - b. Repeat for the opposite lift cylinder.

IMPORTANT:

Ensure the safety props engage over the cylinder piston rods. If the safety prop does **NOT** engage properly, raise the header until the safety prop fits over the rod.

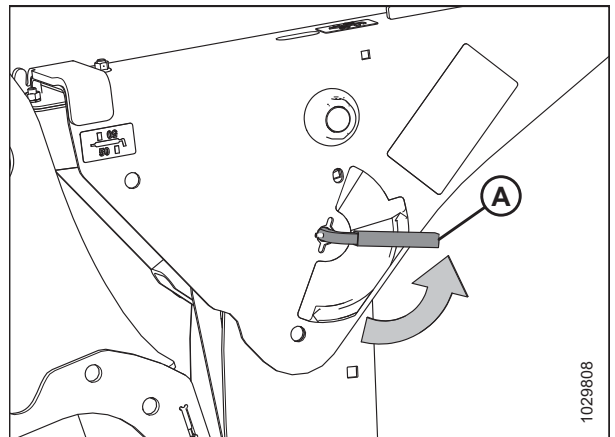

Figure 4.194: Safety Prop Lever

18. Install clevis pin (A) through the support and foot, and secure with hairpin (B). Repeat for opposite side.

IMPORTANT:

Ensure clevis pin (A) is fully inserted and the hairpin is installed behind the bracket.

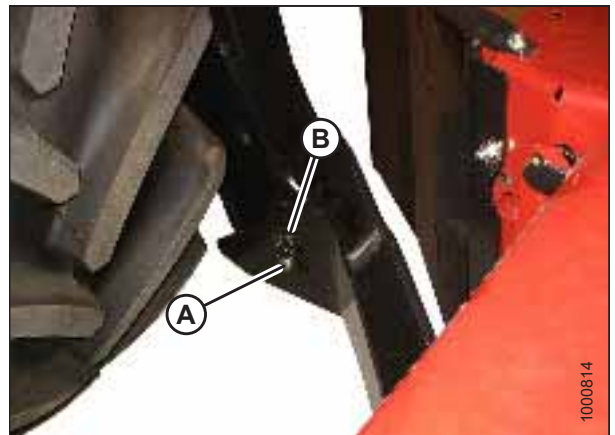

Figure 4.195: Header Support

OPERATION

19. Disengage the safety props on both lift cylinders as follows:
 - a. Turn lever (A) away from the header to raise the safety prop until the lever locks into the vertical position.
 - b. Repeat for the opposite cylinder.

NOTE:

If the safety prop will **NOT** disengage, raise the header to release the prop.

20. Repeat for opposite side.

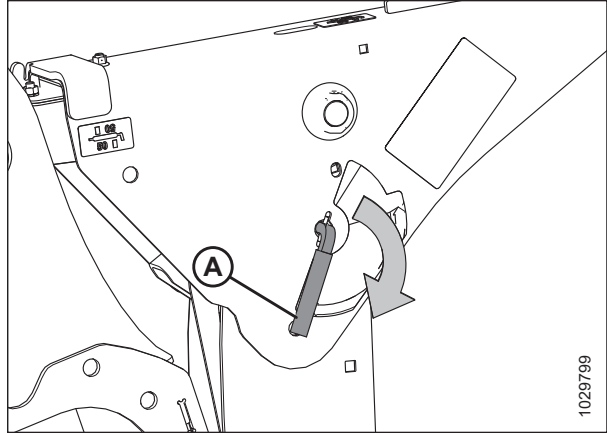

Figure 4.196: Safety Prop Lever

! WARNING

Check to be sure all bystanders have cleared the area.

21. Start engine and press HEADER DOWN switch (A) on GSL to fully lower header.

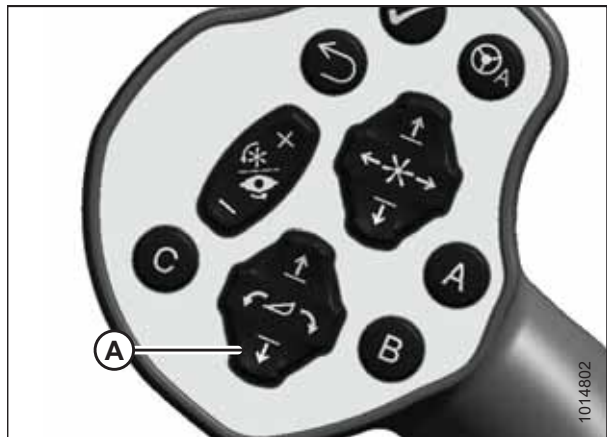

Figure 4.197: GSL

22. Press rotary scroll knob (A) on Harvest Performance Tracker (HPT) to highlight QuickMenu options.
23. Rotate scroll knob (A) to highlight HEADER FLOAT symbol (B), and press scroll knob to select.



Figure 4.198: HPT Display

OPERATION

24. Turn scroll knob (A) to highlight left or right float setting and press knob (A) to activate selection.
25. Rotate scroll knob (A) to adjust float setting and press knob (A) when finished.

NOTE:

Float adjustments of 1.0 (out of 10) change the header weight at the cutterbar by approximately 91 kg (200 lb.). Adjust float in increments of 0.05 to optimize field performance.

26. Shut down the engine, and remove the key from the ignition.
27. Grasp one end of the rotary header and lift. Lifting force should be 426–471 N (95–105 lbf) and should be the same at both ends.



Figure 4.199: HPT Display

OPERATION

Connecting R85 4.9 m (16 ft.) Rotary Disc Header Hydraulics

The rotary disc header's motor is supplied by the windrower's hydraulic system and its performance is monitored and controlled by the windrower's electronic control system. Three hydraulic hoses and an electrical harness connect the header to the windrower.

Refer to the following steps to attach the hydraulic hoses and electrical harness from the header to the windrower.

NOTE:

These steps are also included in the header operator's manual.

1. Open the left-side platform (A). For instructions, refer to [5.4.1 Opening Platform, page 304](#).

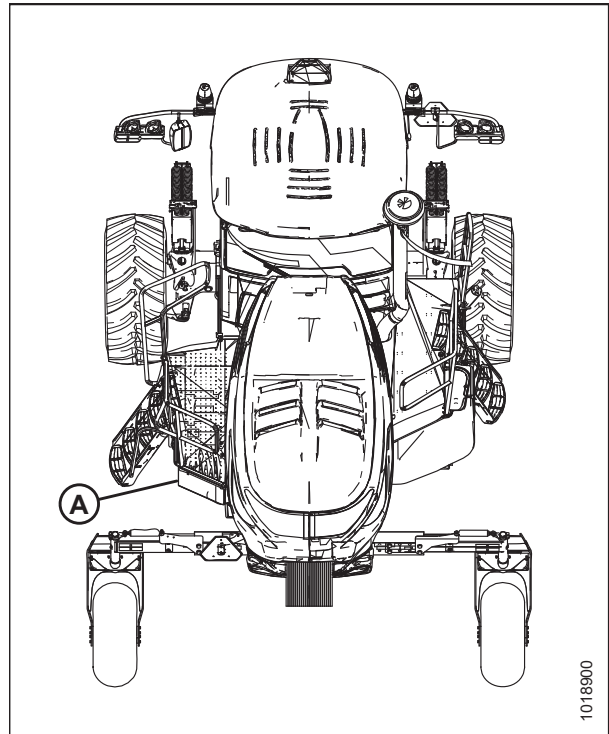

Figure 4.200: M1240 Windrower

2. Route hose bundle (A) from header to under windrower frame.

IMPORTANT:

Route hoses as straight as possible and avoid rub/wear points that could damage hydraulic hoses.

3. Insert pin (B) into hole (C) in windrower frame, and place hose bundle on support (D).

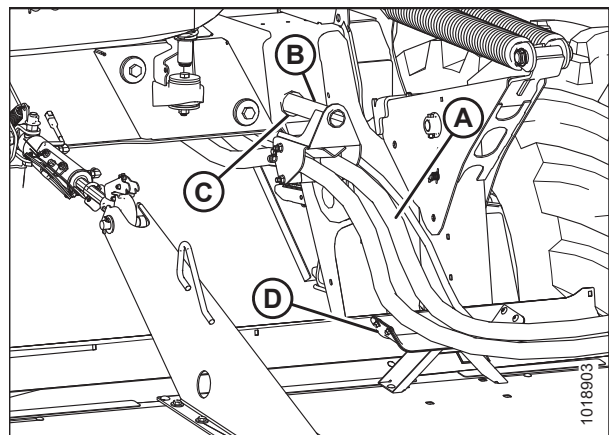

Figure 4.201: Hose and Electrical Routing

OPERATION

4. **Windrowers configured for both rotary disc and draper headers only:** Disconnect hose (A) from windrower receptacle (B) and place in storage cup (C) on multicoupler.

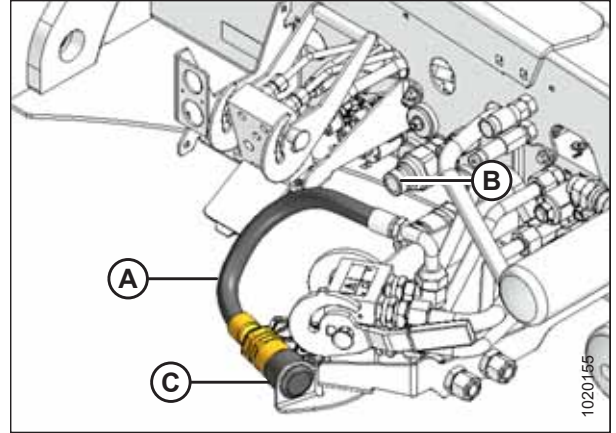

Figure 4.202: Knife Drive Hose on Rotary Disc and Draper Ready Windrower

5. To connect hydraulic hoses to the windrower **with quick-disconnect fittings**, follow these steps:

NOTE:

If hoses are not equipped with quick-disconnect fittings, they can be attached directly to the windrower fittings as described in Step 6, [page 208](#).

NOTE:

Some parts have been removed from the illustration for clarity.

- a. To prevent harmful contamination, use a clean rag to remove dirt and moisture from the couplings.
- b. Connect the disc pressure hose (A) with red cable tie to receptacle (B).
- c. Connect the disc return hose (C) to receptacle (D).
- d. Connect the case drain hose (E) to receptacle (F).
- e. Connect the electrical harness to receptacle (G).

NOTE:

Ensure the hydraulic hoses have sufficient slack to clear the multicoupler without coming into contact with it. If necessary, increase slack in the hoses by loosening the hose holder at the windrower frame and moving the hoses as required.

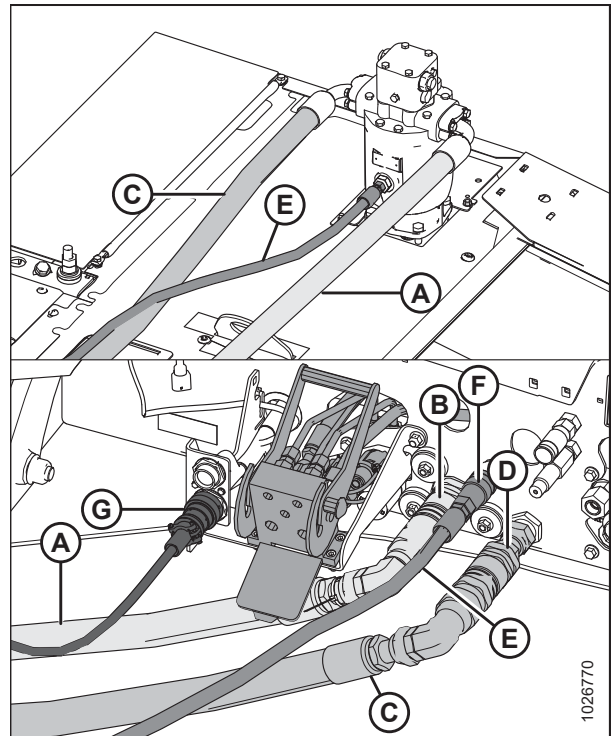

Figure 4.203: Quick-Disconnect Hydraulic and Electrical Connections

OPERATION

6. To directly connect the hydraulic hoses to the windrower with hard-plumbed fittings, follow these steps:

NOTE:

Some parts have been removed from the illustration for clarity.

- To prevent harmful contamination, use a clean rag to remove dirt and moisture from the fittings.
 - Attach the disc pressure hose (A) to fitting on frame and torque to 205–226 Nm (151–167 lbf-ft).
 - Connect the disc return hose (B) to fitting on frame and torque to 205–226 Nm (151–167 lbf-ft).
 - Connect the case drain hose (C) to fitting on frame and tighten.
 - Connect the electrical harness to receptacle (D).
7. Close the side platform. For instructions, refer to [5.4.2 Closing Platform, page 304](#).

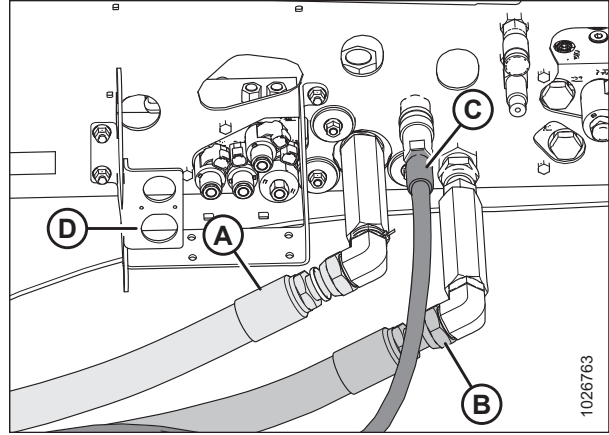

Figure 4.204: Hard-Plumbed Hydraulic and Electrical Connections on a Rotary Disc Ready Windrower

Detaching R85 4.9 m (16 ft.) Rotary Disc Header

WARNING

To avoid bodily injury or death from unexpected startup of the machine, always stop the engine and remove the key from the ignition before leaving the operator's seat for any reason.

WARNING

Check to be sure all bystanders have cleared the area.

- Start the engine, and press header raise switch (A) to raise the header to the maximum height.
- Shut down the engine, and remove the key from the ignition.



Figure 4.205: Ground Speed Lever

OPERATION

3. Engage the safety props on both lift cylinders as follows:
 - a. Pull lever (A) toward you to release, and then rotate toward header to lower the safety prop onto the cylinder.
 - b. Repeat for the opposite lift cylinder.

IMPORTANT:

Ensure the safety props engage over the cylinder piston rods. If the safety prop does **NOT** engage properly, raise the header until the safety prop fits over the rod.

4. Open the platform. For instructions, refer to [5.4.1 Opening Platform, page 304](#).
5. Disconnect the following electrical harness and hydraulic hoses from the windrower:
 - a. Disconnect the disc pressure hose from fitting (A).
 - b. Disconnect the disc return hose from fitting (B).
 - c. Disconnect the case drain hose from fitting (C).
 - d. Disconnect the electrical harness from receptacle (D).

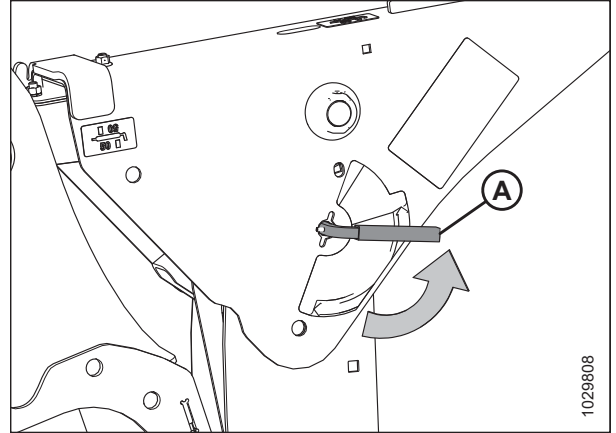

Figure 4.206: Safety Prop Lever

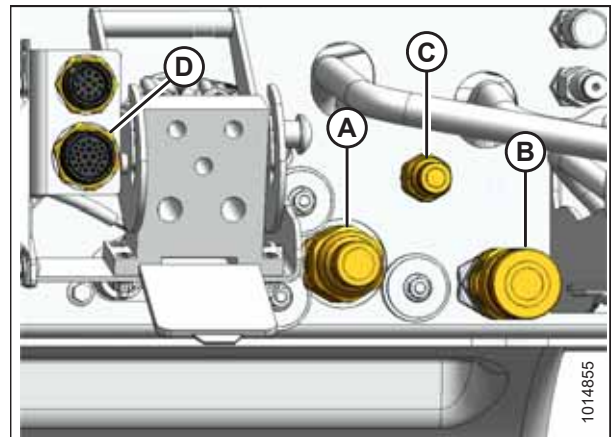

Figure 4.207: Header Drive Hydraulics

6. Remove hairpin (B) from clevis pin (A) and remove clevis pin from header support (C) on both sides of header.

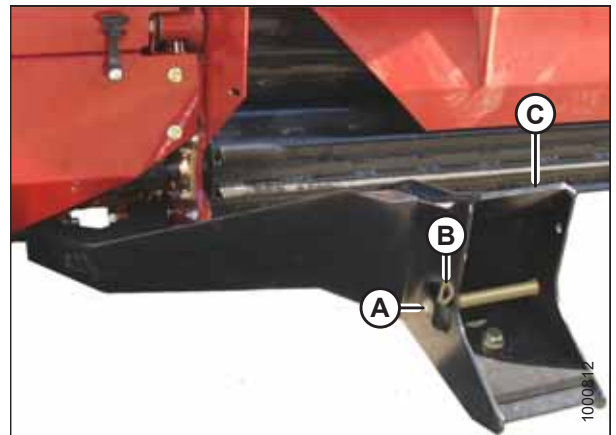

Figure 4.208: Header Supports

OPERATION

7. For windrowers with self-aligning center-link: Release center-link latch (A).

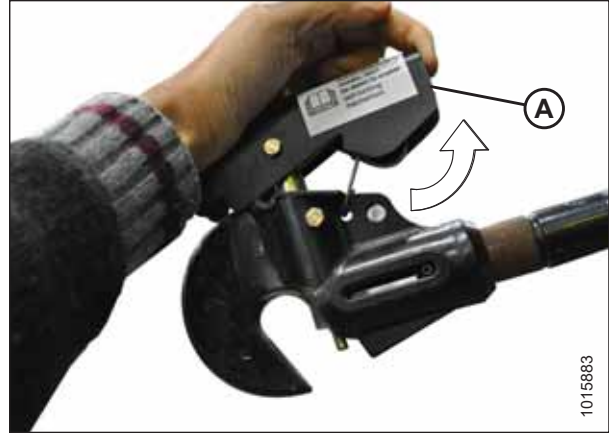

Figure 4.209: Center-Link

8. Disengage the safety props on both lift cylinders as follows:
 - a. Turn lever (A) away from the header to raise the safety prop until the lever locks into the vertical position.
 - b. Repeat for the opposite cylinder.

NOTE:

If the safety prop will **NOT** disengage, raise the header to release the prop.

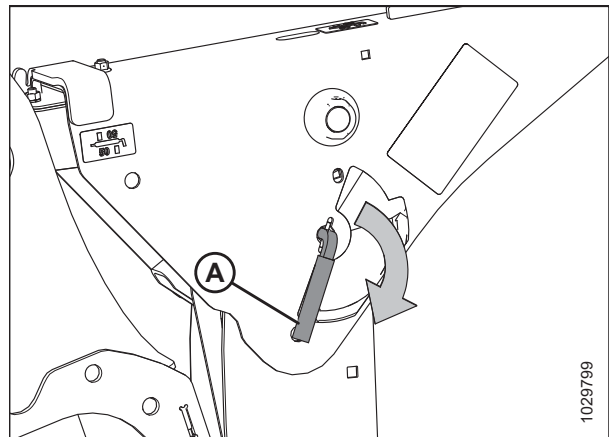

Figure 4.210: Safety Prop Lever

9. Disengage safety prop by turning lever (A) downwards until lever locks into the vertical position.
10. Repeat for the opposite side.

⚠ WARNING

Check to be sure all bystanders have cleared the area.

11. Start engine and remove header float when prompted by the Harvest Performance Tracker (HPT).

NOTE:

If not prompted by the HPT to remove float, remove float manually. For instructions, refer to *Removing and Restoring Float*, page 224.

12. Lower the header to the ground.

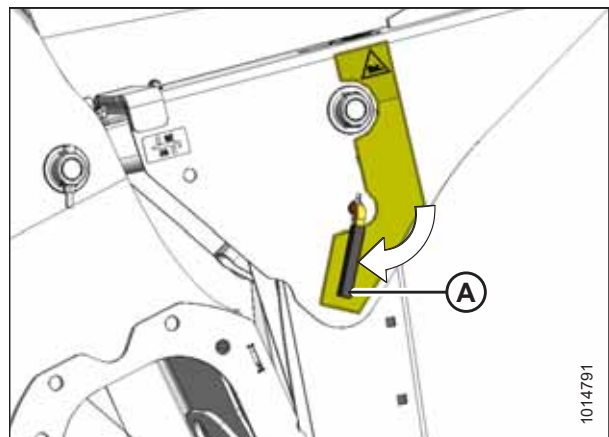

Figure 4.211: Safety Props

OPERATION

13. **For windrowers with self-aligning center-link:** Use HEADER TILT cylinder switches (A) on GSL to release load on center-link cylinder.
14. Operate the link lift cylinder with the REEL UP switch (B) to disengage the center-link from the header.

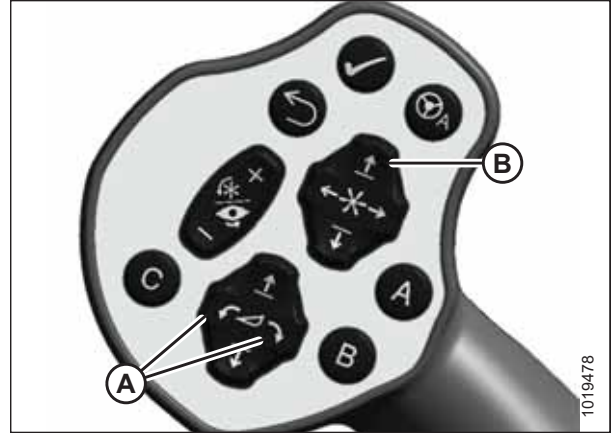

Figure 4.212: GSL

15. **For windrowers without self-aligning center-link:** Shut off the engine and remove the key.
16. Lift hook release (B) and lift hook (A) off header pin.

WARNING

Check to be sure all bystanders have cleared the area.

17. Start the engine.

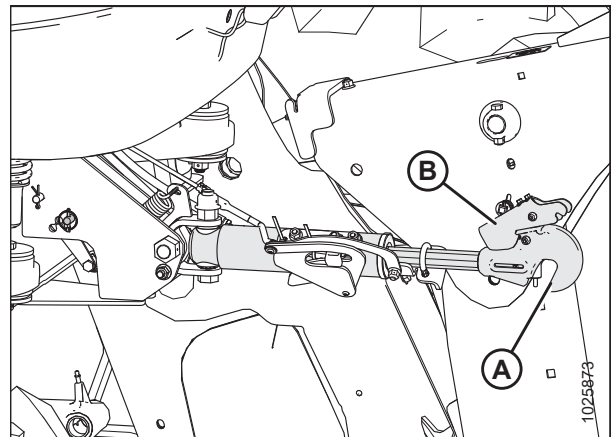

Figure 4.213: Hydraulic Center-Link

18. Slowly back the windrower away from header.
19. Reinstall clevis pin (A) through support (C) and secure with hairpin (B). Repeat for opposite side.

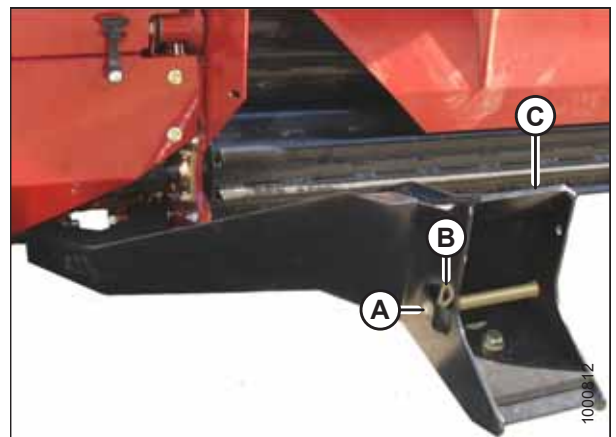

Figure 4.214: Header Support

4.5 Adjusting Header Settings on the Harvest Performance Tracker

Before operating the header, ensure the Harvest Performance Tracker (HPT) settings are appropriate for your header.

1. Navigate to SETTINGS menu with soft key 5 and HPT scroll knob. For instructions, refer to [3.17.2 Navigating the Harvest Performance Tracker Display, page 80](#) if required.
2. Scroll to SET-UP HEADER option (A) and press the scroll knob to select it.

NOTE:

Settings vary depending on the header type.

3. Scroll to highlight the appropriate option and press the scroll knob to select it.

For example, if a draper header is attached, and ATTACHMENTS (B) is selected, the available choice is DOUBLE DRAPER DRIVE.

4. Press BACK button (A) on the HPT to return to the previous level within the menu structure.
5. Press HOME button (B) on the HPT to return to the last selected run screen (or header disengaged screen).

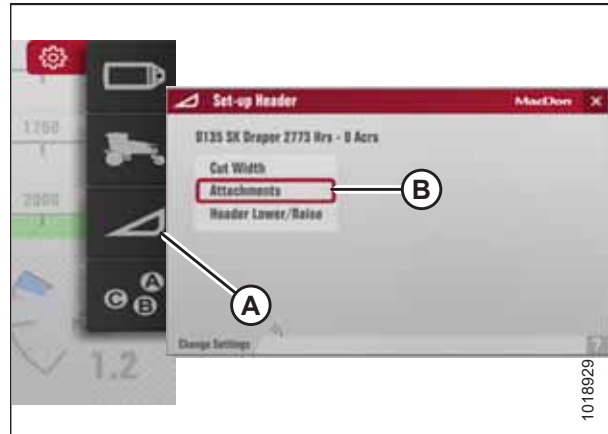

Figure 4.215: Header Settings



Figure 4.216: HPT Display

4.6 Calibrating the Header Systems

The Harvest Performance Tracker (HPT) recognizes when a header is attached to the windrower and determines the systems that require calibration.

The following sensors will be calibrated depending on header type:

- Header height
- Header angle
- Header float left
- Header float right
- Reel height
- Reel fore-aft
- Swath compressor
- Knife Drive

Recalibration is required if the HPT is replaced, a position sensor is replaced, sensor readouts are erratic, pump has been replaced, or if a new header type or attachment is connected to the windrower.

Refer to following topics for calibrating various header systems;

- [4.6.1 Calibrating the Knife Drive on the Harvest Performance Tracker Display, page 213](#)
- [4.6.2 Calibrating Header Position Sensors on the Harvest Performance Tracker Display, page 216](#)

4.6.1 Calibrating the Knife Drive on the Harvest Performance Tracker Display

When a header is attached to a windrower, the Harvest Performance Tracker (HPT) will recognize the header ID and configure the windrower accordingly. The header must be calibrated to ensure that the knife drive pump output is accurate.



WARNING

Never start or move the machine until you are sure all bystanders have cleared the area.

1. Start the engine.
2. Press soft key 5 (A) to open the Harvest Performance Tracker (HPT) main menu.

NOTE:

Calibrations **MUST** be performed with the engine running. Some calibrations will not be available with engine off.

3. Use HPT scroll knob (B) or the ground speed lever (GSL) scroll wheel (not shown) to highlight SETTINGS icon (C).
4. Press HPT scroll knob (B) or the GSL SELECT button (not shown) to activate the settings menu options.

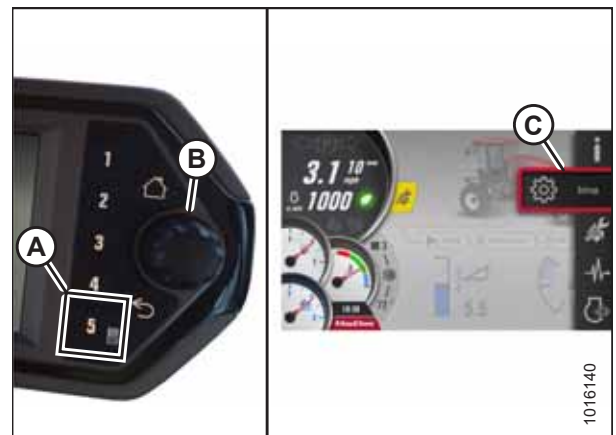

Figure 4.217: Opening the Main Menu

OPERATION

5. Scroll to WINDROWER SETTINGS icon (A) and press SELECT.
6. Scroll to CALIBRATION icon (B), and press SELECT to open the Calibration Selection screen.

NOTE:

The F3 shortcut button on the operator's console will also open the WINDROWER SETTINGS menu.

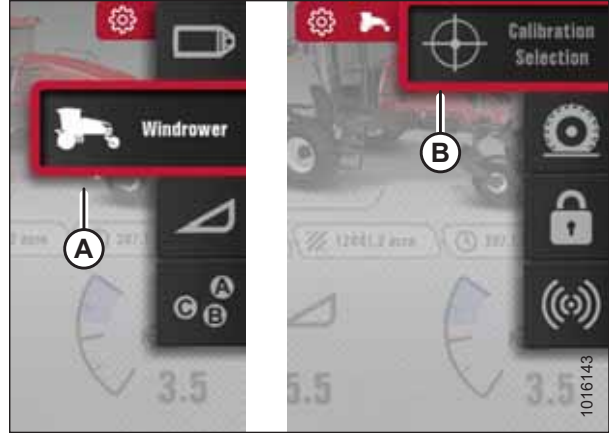

Figure 4.218: Windrower Settings Icon and Calibration Submenu Icon

7. In the Calibration Selection screen, scroll to Knife Drive (A) and press SELECT.
8. Engage the header.

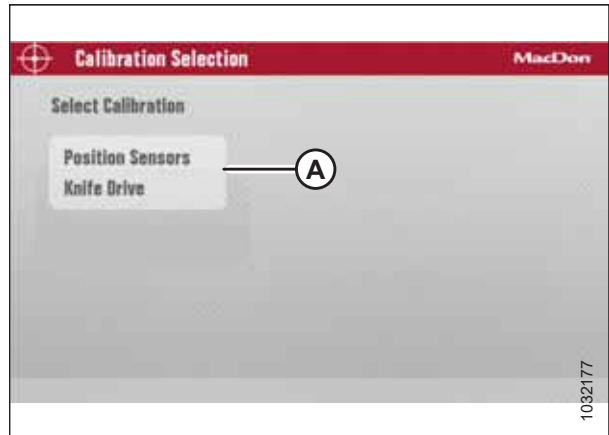

Figure 4.219: Calibration Selection Screen

NOTE:

If calibration is selected with header disengaged, WARNING (A) will appear. Engage the header. PLAY icon (B) will appear after you engage the header.

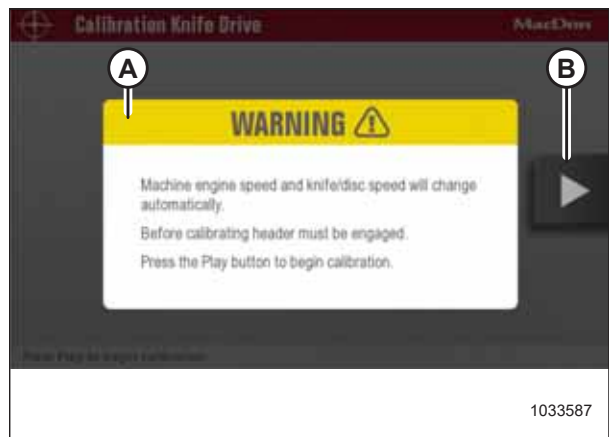

Figure 4.220: Engage Header Warning

OPERATION

10. Press the PLAY icon on the screen to begin the calibration process. The display on the screen will change to show that calibration has started.

NOTE:

If the engine speed is less than 1500 rpm prior to starting the calibration, the system will accelerate the engine speed to 1500 rpm.



Figure 4.221: Calibration Screen

11. When Stage 1 of the calibration is complete, press PLAY icon (A) on the screen to continue with Stage 2 of the calibration process.

NOTE:

Knife drive calibration is completed in nine stages.



Figure 4.222: Calibration Page

12. Press the PLAY icon to begin the calibration process.

NOTE:

During the calibration sequence, the engine rpm and header speed will increase and decrease multiple times.

NOTE:

Press the X icon (A) on the screen or use the HEADER DISENGAGE switch at any time during the calibration process to exit calibration without saving. The engine speed will return to the original rpm prior to starting the calibration process.



Figure 4.223: Calibration Page

NOTE:

If an error message (A) appears when calibrating the knife drive system, follow the instructions in the message to fix the error. Press X (B) to exit the message. The following list is an example of items to check if the knife calibration fails:

- Confirm the engine and hydraulics are at operating temperature.
- Confirm the hydraulic system is free of any restrictions and is in working order.
- Confirm the throttle is working:
 - Check the engine codes to confirm engine is not derated or throttle inhibited
 - The throttle is controlled over the powertrain CAN network (CAN network 1). Check the powertrain CAN network wiring and connectors for open or intermittent connection
- Confirm the sensor mounting is fastened properly and sensor gap meets specification.
- Check the sensor wiring and connectors for intermittent connection.
- Replace the sensor.

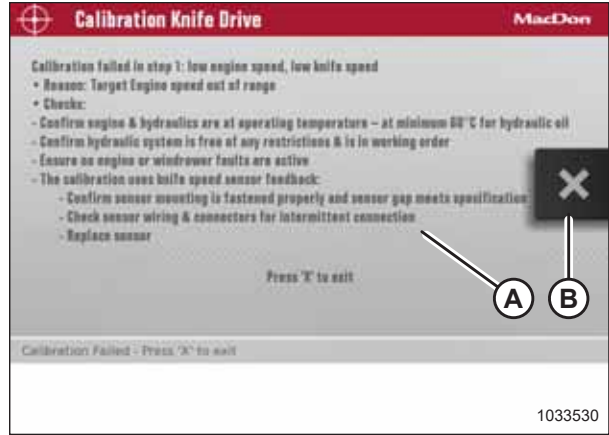

Figure 4.224: Calibration Page

4.6.2 Calibrating Header Position Sensors on the Harvest Performance Tracker Display

WARNING

Never start or move the machine until you are sure all bystanders have cleared the area.

1. Start the engine.
2. Press soft key 5 (A) to open the Harvest Performance Tracker (HPT) main menu.

NOTE:

Calibrations **MUST** be performed with the engine running. Some calibrations will not be available with engine off.

3. Use HPT scroll knob (B) or the ground speed lever (GSL) scroll wheel (not shown) to highlight SETTINGS icon (C).
4. Press HPT scroll knob (B) or the GSL SELECT button (not shown) to activate the settings menu options.

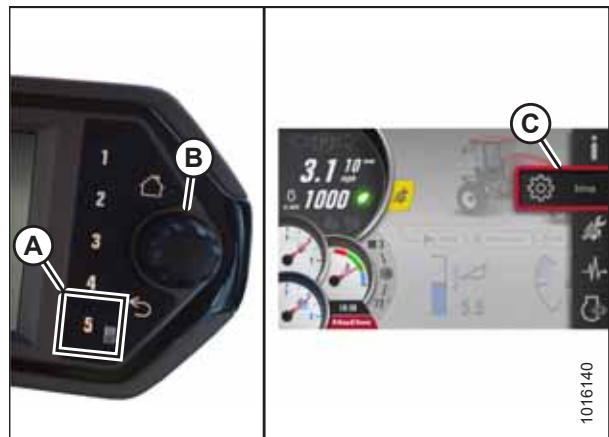

Figure 4.225: Opening the Main Menu

OPERATION

5. Scroll to WINDROWER SETTINGS icon (A) and press SELECT.
6. Scroll to CALIBRATION icon (B), and press SELECT to open the Calibration Selection screen.

NOTE:

The F3 shortcut button on the operator's console will also open the WINDROWER SETTINGS menu.

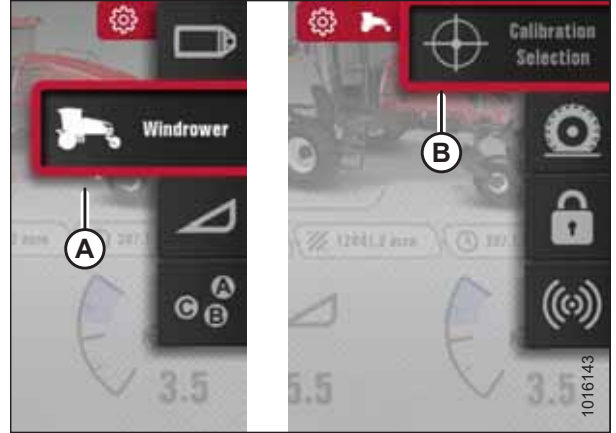

Figure 4.226: Windrower Settings Icon and Calibration Submenu Icon

7. In the Calibration Selection screen, scroll to Position Sensors (A) and press SELECT.

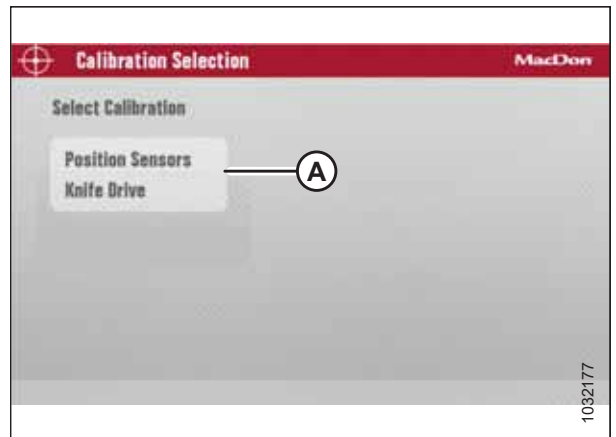

Figure 4.227: Calibration Selection Screen

NOTE:

Pressing X icon (A) on the screen (or pressing the HOME, BACK or any GSL button [buttons not shown]) at any time during calibration process will EXIT calibration without saving. The engine speed will also return to the original rpm prior to starting the calibration process.

NOTE:

If a sensor goes out of its normal operating range during the calibration process, calibration will stop and a message will appear on the screen indicating that the sensor is out of range.



Figure 4.228: Calibration Screen

OPERATION

- When stage one of the calibration is complete, press PLAY icon (A) on the screen to continue with stage two of the calibration process.



Figure 4.229: Calibration Screen

- When stage two of the calibration is complete, press RESUME icon (A) on the screen to set HEADER FLOAT, or press HOME or BACK button (not shown) to exit without setting the float.

NOTE:

The engine speed returns to the speed prior to calibration when stage two calibration is complete.



Figure 4.230: Calibration Screen

NOTE:

If the voltage of any sensor sweeps below what is acceptable during calibration, a message will be displayed after completing the calibration with a list of sensors with voltage range that is not acceptable. Adjust the sensor and repeat the calibration process from the beginning.



Figure 4.231: Sample of Failed Calibration Display Message

4.7 Operating a Header

This section describes the operating instructions for the following header types when attached to a MacDon M1240 Windrower: A40DX Auger Header, D1XL Series Draper Header, D1X Series Draper Header, R113 or R216 Series Rotary Disc Header.

4.7.1 Engaging and Disengaging Header Safety Props

When engaged, safety props prevent a header from dropping suddenly if the lift system hydraulics lose pressure.

DANGER

To avoid bodily injury or death from unexpected start-up or fall of a raised machine, always stop engine and remove key before leaving the operator's seat, and always engage safety props before going under the machine for any reason.

1. Start the engine.
2. Press HEADER UP switch (A) to raise the header to maximum height.

NOTE:

If one end of the header does **NOT** fully raise, rephase the lift cylinders as follows:

- a. Press and hold HEADER UP switch (A) until both cylinders stop moving.
 - b. Continue to hold the switch for 3–4 seconds. Cylinders are now phased.
3. Shut down the engine, and remove the key from the ignition.



Figure 4.232: Ground Speed Lever

4. Engage the safety props on both lift cylinders as follows:
 - a. Pull lever (A) toward you to release, and then rotate toward header to lower the safety prop onto the cylinder.
 - b. Repeat for the opposite lift cylinder.

IMPORTANT:

Ensure the safety props engage over the cylinder piston rods. If the safety prop does **NOT** engage properly, raise the header until the safety prop fits over the rod.

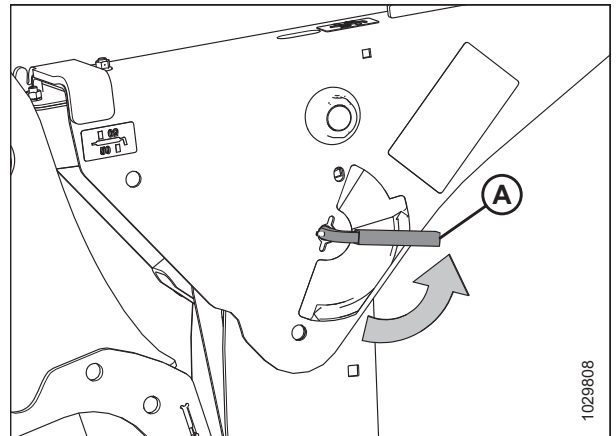

Figure 4.233: Safety Prop Lever

OPERATION

5. Disengage the safety props on both lift cylinders as follows:
 - a. Turn lever (A) away from the header to raise the safety prop until the lever locks into the vertical position.
 - b. Repeat for the opposite cylinder.

NOTE:

If the safety prop will **NOT** disengage, raise the header to release the prop.

6. Start the engine.
7. Lower the header fully.
8. Shut down the engine, and remove the key from the ignition.

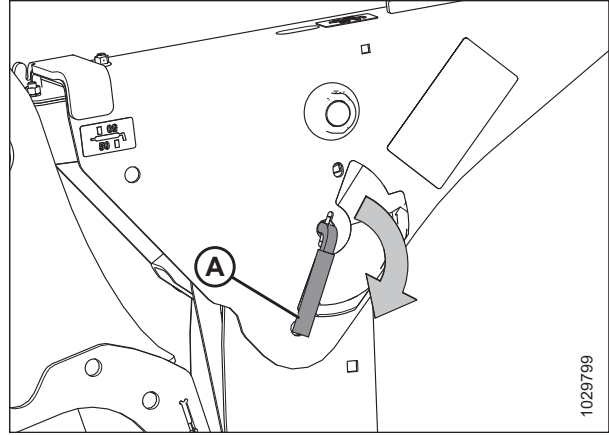

Figure 4.234: Safety Prop Lever

4.7.2 Header Float

The windrower is equipped with float springs that are fully adjustable with hydraulic cylinders. Spring tension is adjustable from 0 to maximum tension through the Harvest Performance Tracker (HPT). The header float feature allows the header to closely follow ground contours and to respond quickly to sudden changes and obstacles. The float setting is ideal when the cutterbar is on the ground with minimal bouncing, scooping, or pushing soil.

IMPORTANT:

- Set the header float as light as possible—without excessive bouncing—to avoid frequent breakage of knife components, scooping soil, or soil build-up at the cutterbar in wet conditions.
- Avoid excessive bouncing (resulting in a ragged cut) by operating at a slower ground speed when the float setting is light.
- Before setting header float, install header options (upper cross auger, skid shoes, transport kit, etc.). If the Slow Speed Transport (SST) tow bar will be stored on the header during operation, set the float with the tow bar in place.
- Adjust the float when adding or removing optional attachments that affect the weight of the header.

Checking Float

WARNING

To avoid bodily injury or death from unexpected startup of the machine, always stop the engine and remove the key from the ignition before leaving the operator’s seat for any reason.

WARNING

Never start or move the machine until you are sure all bystanders have cleared the area.

1. Start the engine.
2. Use HEADER TILT switches (A) on the ground speed lever (GSL) to set the center-link to the mid-range position (5.0 on the Harvest Performance Tracker [HPT]).
3. If checking float with a draper header attached, set the reel to the normal operating position.
4. Using HEADER DOWN switch (B), lower the header fully. The header lift cylinders will fully retract.
5. Ensure the header is level with the ground with zero tilt.

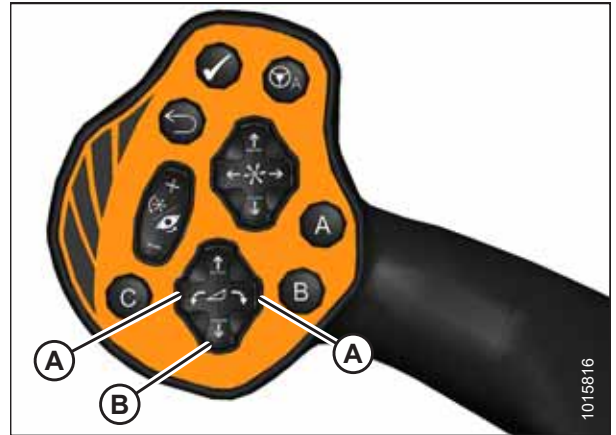

Figure 4.235: GSL

6. Shut down the engine, and remove the key from the ignition.
7. Grasp one end of the header and lift. The force required to lift the header should be the same at both ends (refer to Table 4.4, page 221).

Table 4.4 Target Header Float Values

Header Type	Force Required to Lift Header at the Ends with Lift Cylinder Fully Retracted
Draper	335–380 N (75–85 lbf) with stabilizer/transport wheels raised (if equipped)
Auger	335–380 N (75–85 lbf)
Rotary Disc	426–471 N (95–105 lbf)

8. Restart the engine, and adjust float as required. For instructions, refer to *Setting the Float*, page 222.

NOTE:

Increasing the float value on the HPT makes the header feel lighter.

OPERATION

Setting the Float

The float can be set for windrowing with the cutterbar on the ground or with the cutterbar off the ground (normally used with the draper header).

Cutterbar on ground

The optimum float setting lets the header follow the contour of the terrain.

1. Press rotary scroll knob (A) on the HPT to display the QuickMenu system.
2. Rotate scroll knob (A) to highlight header float icon (B) and press scroll knob to select.



Figure 4.236: HPT Run Screen

3. Turn scroll knob (A) to highlight left (B) or right (C) float and press knob (A) to activate selection.
4. Rotate scroll knob (A) to adjust the float setting and press the knob when finished. Float is now set.

NOTE:

Float adjustments of 1.0 (out of 10) change the header weight at the cutterbar by approximately 91 kg (200 lb.). Adjust float in increments of 0.05 to optimize field performance.

5. Use soft key 3 (D) to remove/resume float and deck position to previous setting for the attached header.



Figure 4.237: HPT Float Settings

OPERATION

Cutterbar off ground – draper header only

The optimum float setting and stabilizer wheel setting lets the header cut the crop evenly with minimal bouncing.

1. Set the center-link to mid-range position (5.0 on the Harvest Performance Tracker [HPT]). For instructions, refer to [4.7.4 Adjusting Header Angle, page 227](#).
2. Set the cutting height with header height controls on the GSL. For instructions, refer to [4.7.5 Setting Header Height, page 229](#).

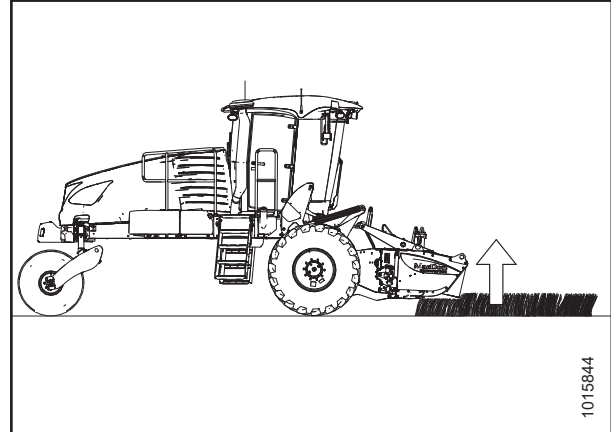

Figure 4.238: Header Float – Cutterbar off Ground

3. Press rotary scroll knob (A) on the HPT to display the QuickMenu system.
4. Rotate scroll knob (A) to highlight header float icon (B) and press the scroll knob to select.



Figure 4.239: HPT Run Screen

5. Turn scroll knob (A) to highlight left (B) or right (C) float and press knob (A) to activate selection.
6. Turn scroll knob (A) to adjust the float setting and press the knob when finished.

IMPORTANT:

Float adjustments of 1.0 (out of 10) change the header weight at the cutterbar by approximately 91 kg (200 lb.). Adjust float in increments of 0.05 to optimize field performance.

7. The float is now set.
8. Use soft key 3 (D) to remove/resume float and deck position to previous setting for the attached header.



Figure 4.240: HPT Float Settings

OPERATION

Removing and Restoring Float

Follow these steps to remove and restore the header float settings:

1. Press rotary scroll knob (A) on the Harvest Performance Tracker (HPT) to display the QuickMenu system or press F1 on the console.
2. Rotate scroll knob (A) to highlight HEADER FLOAT icon (B) and press the scroll knob to select.



Figure 4.241: HPT Run Screen

3. Press soft key 3 (A) to remove or restore the header float.

NOTE:

If the header float is active, the icon at soft key 3 will say REMOVE FLOAT; if header float has been removed, the icon will say RESTORE FLOAT.



Figure 4.242: HPT Display – Adjusting Float

4.7.3 Header Drive

All header drive controls are conveniently located on the operator's console and on the ground speed lever (GSL) handle.

NOTE:

Some controls are optional equipment and may not be present in your unit. Some controls may be installed, but will be nonfunctional for certain headers.

Engaging and Disengaging the Header

The HEADER ENGAGE switch engages and disengages the header drive.

! WARNING

Check to be sure all bystanders have cleared the area.

! DANGER

To avoid bodily injury or death from unexpected start-up or fall of a raised machine, always stop engine and remove key before leaving the operator's seat, and always engage safety props before going under the machine for any reason.

1. Start the engine.
2. **To engage header:** Push and hold HEADER ENGAGE switch (A) down, while pulling up on the collar (B).

To disengage header: Push HEADER ENGAGE switch (A) down.



Figure 4.243: Header Engage Switch

OPERATION

Reversing the Header

NOTE:

R1 Series and R2 Series Rotary Disc Headers do **NOT** have any reverse capability.

When reversing, the following header functions will turn in reverse:

- D1XL Series Draper Headers: knife
- D1X Series Draper Headers: knife
- A40DX Auger Headers: knife, conditioner, auger and reel
- A40DX GSS Auger Headers: knife, auger and reel

Reverse the header as follows:

1. Press and hold HEADER DRIVE REVERSE button (A).
2. Press and hold HEADER ENGAGE switch (B). Pull up on collar (C), until switch (B) is in the ENGAGED position.
3. When you are ready to return to forward operation, release HEADER DRIVE REVERSE button (A) to stop the header.
4. Push down HEADER ENGAGE switch (B) to OFF position. The header can now be restarted. For instructions, refer to [Engaging and Disengaging the Header, page 225](#).



Figure 4.244: Header Drive Controls

4.7.4 Adjusting Header Angle

Header angle is the angle between the ground and the drapers/cutterbar. It is adjustable to accommodate crop conditions and soil types.

Refer to the appropriate header operator's manual for the range of adjustment and recommended settings for your particular header.

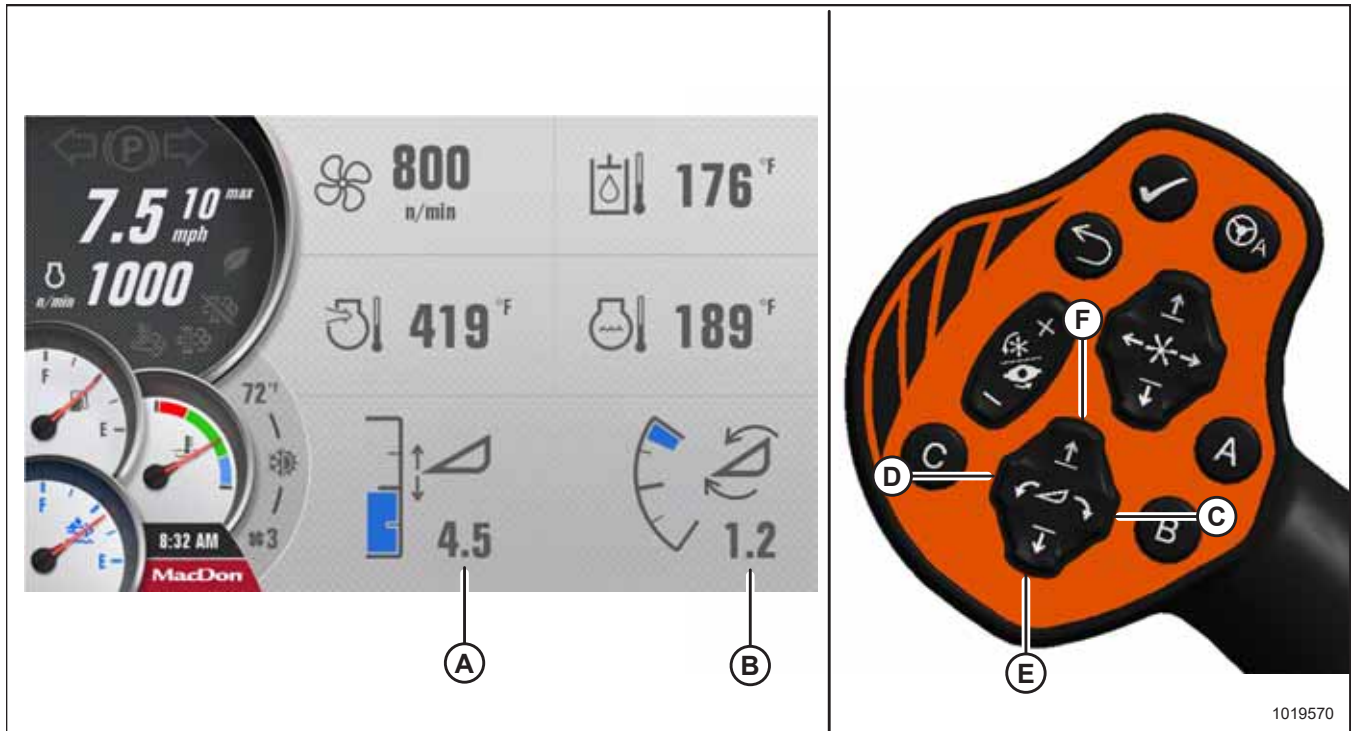

Figure 4.245: HPT Display and GSL

The header angle can be hydraulically adjusted from the cab without shutting down the windrower. A readout on the Harvest Performance Tracker (HPT) display indicates HEADER HEIGHT (A) and HEADER ANGLE (B).

IMPORTANT:

- Changing header angle affects header float because it has the effect of making the header lighter or heavier. Adjust float as required. For instructions, refer to [Setting the Float, page 222](#).
- To prevent excessive guard breakage when conditions are suited to lighter float (e.g., rocky), do **NOT** use the ground speed lever (GSL) TILT CONTROL (C) and (D) while in motion. Instead, use HEADER HEIGHT (E) and (F) controls.

Adjust the header angle as follows:

- To decrease (flatten) header angle, operate the HEADER TILT UP switch (C) on the GSL to retract the cylinder.
- To increase (steepen) header angle, operate the HEADER TILT DOWN switch (D) on the GSL to extend the cylinder.

NOTE:

The HEADER TILT switches (C) and (D) can be locked out to prevent unintentional header angle changes when pressing HEADER HEIGHT control switches (E) and (F). For instructions, refer to [3.17.5 Activating Control Locks, page 99](#).

OPERATION

Checking Self-Locking Center-Link Hook

Periodically check the operation of the hook locking mechanism to ensure that it is working properly.

WARNING

To avoid bodily injury or death from unexpected startup of the machine, always stop the engine and remove the key from the ignition before leaving the operator's seat for any reason.

1. If a header is attached to the windrower, lower the header to the ground.
2. Shut down the engine, and remove the key from the ignition.
3. Pull up on handle (A) to release the locking device, and lift the hook off the header pin.

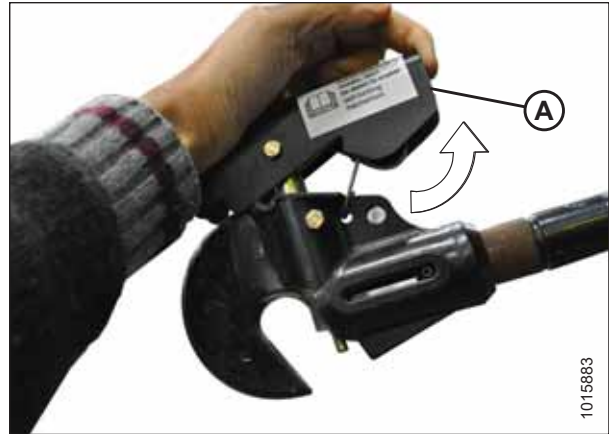

Figure 4.246: Center-Link

4. Lower handle (A) into the locked position.
5. Push up on lock pin (B) only (not the actuator rod [C]). Handle should catch on casting and pin should **NOT** lift.

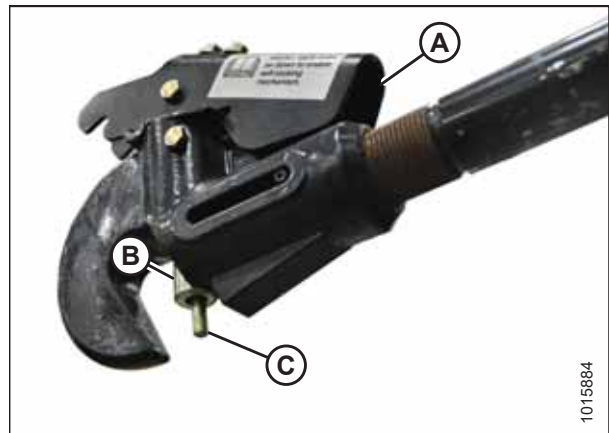

Figure 4.247: Center-Link Hook

6. Push up on the actuator rod. The lock pin should lift with the handle.



Figure 4.248: Center-Link Hook

4.7.5 Setting Header Height

Header height is adjusted by raising or lowering the header with the HEADER UP (A) or HEADER DOWN (B) switches on the ground speed lever (GSL).



Figure 4.249: GSL

HEADER HEIGHT (A) is always displayed on the Harvest Performance Tracker (HPT) screen.

NOTE:

Draper headers: Settings for the fore-aft, reel height, and header height are limited as follows to prevent the reel from contacting the cab roof:

- If you increase header height (A) to greater than 7.0 while reel fore-aft (B) is greater than 5.0, and reel height (C) is greater than 7.0, the reel fore-aft will automatically move forward to 5.0 or less to avoid contacting the cab roof.
- After the reel fore-aft automatically moves, you will then have to manually adjust the fore-aft.
- For instructions about operating the reel fore-aft, refer to [4.8.2 Adjusting Reel Fore-Aft Position, page 234](#).

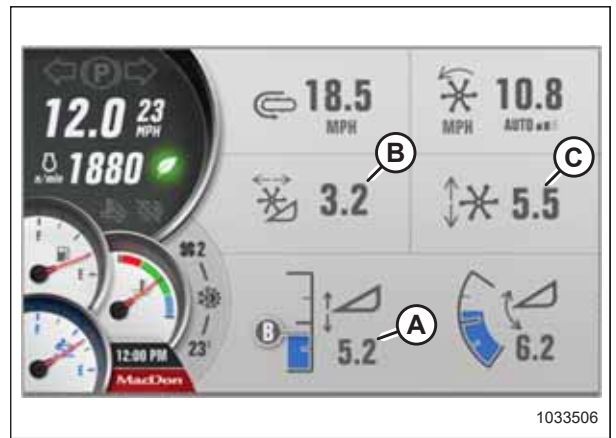

Figure 4.250: HPT Display – Draper Header Shown

4.7.6 Double Windrowing

The Double Windrow Attachment (DWA) allows two conditioned windrows from an A40DX Auger Header or R85 Rotary Disc Header to be laid down side-by-side for faster pickup.

Conditioned crop is deposited onto the side delivery draper and delivered beside the windrower.

Raising the side delivery system shuts off the draper and allows the crop to be deposited between the windrower wheels—as it would be without the side delivery system.

Refer to the MacDon Double Windrow Attachment (DWA) for M1 Series Windrowers Manual for complete setup, operating, and maintenance instructions. The manual is shipped with the DWA kit.

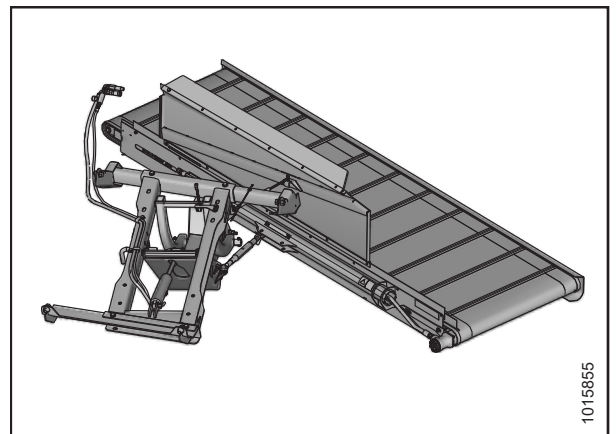

Figure 4.251: DWA

OPERATION

Double Windrow Attachment Deck Position

1. Raise and lower the Double Windrow Attachment (DWA) deck with REEL UP (A) and REEL DOWN (B) switches on ground speed lever (GSL), or on the operator's console.

NOTE:

This can also be done with the One-Touch-Return. For instructions, refer to [One-Touch-Return Buttons \(A, B, C\)](#), page 74.



Figure 4.252: GSL

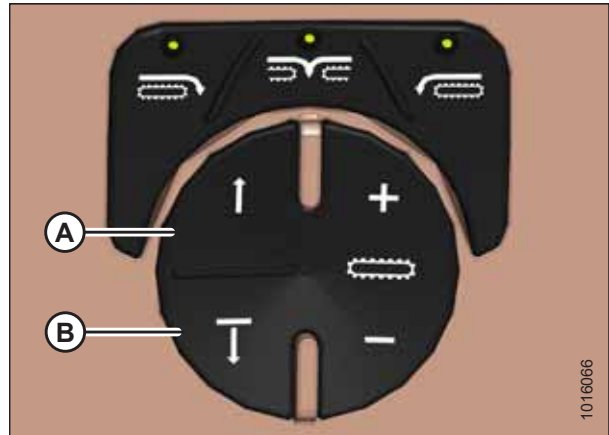

Figure 4.253: Operator's Console Draper Controls

Double Windrow Attachment Conveyor Speed

The Double Windrow Attachment (DWA) conveyor speed is adjustable from the operator's console. Press button (A) to increase the speed or button (B) to decrease the speed.

NOTE:

When the DWA is attached, the conveyor speed adjustment buttons also control header draper speeds.

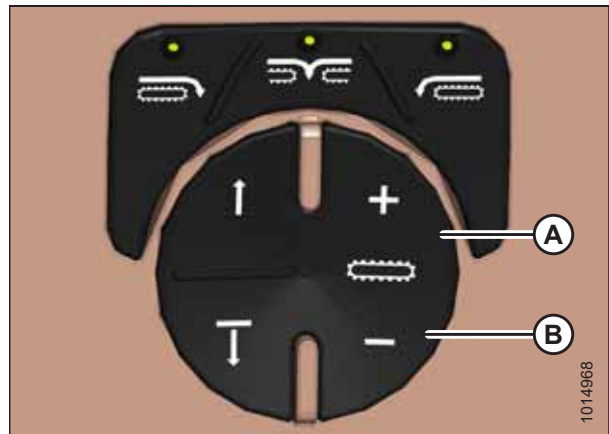

Figure 4.254: Operator's Console

OPERATION

The DWA conveyor speed is also adjustable with the reel fore-aft switches on the GSL. Press switch (A) to increase speed or switch (B) to decrease speed.

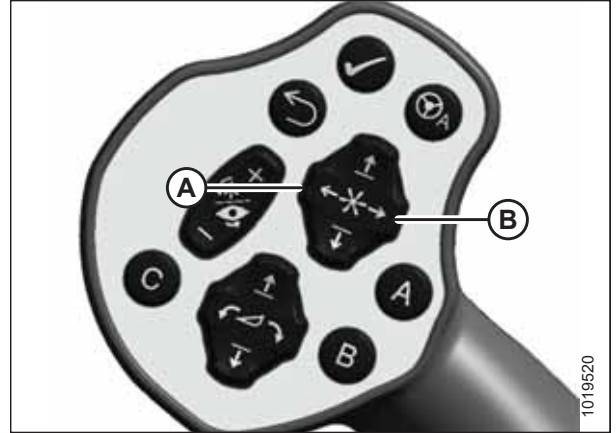

Figure 4.255: GSL

4.7.7 One-Touch-Return

One-Touch-Return allows you to choose and apply three presets to the A, B, and C keys (A) on the ground speed lever (GSL). The presets can be set to control variables such as height, tilt, reel position, and speeds. For instructions, refer to [One-Touch-Return Buttons \(A, B, C\)](#), page 74.



Figure 4.256: GSL

4.7.8 Adjusting Header Raise and Lower Rates

To adjust header raise and lower rates, follow these steps:

1. On the Harvest Performance Tracker (HPT) press soft key 5 (A) to display the Header Lower/Raise menu.
2. Use HPT scroll knob (B) or the ground speed lever (GSL) scroll wheel (not shown) to place the red cursor over SETTINGS icon (C).
3. Press HPT scroll knob (B) or the GSL SELECT button (not shown) to select SETTINGS icon (C).

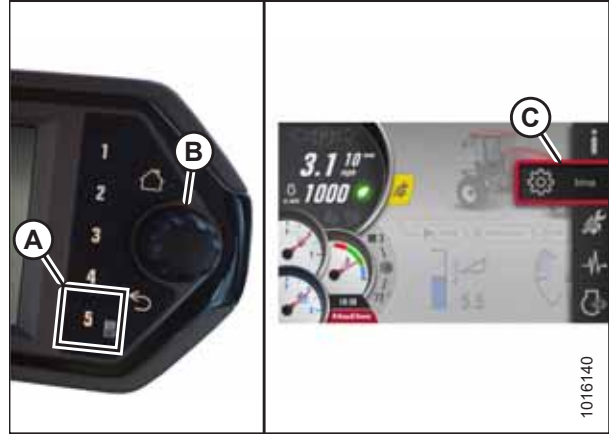

Figure 4.257: Opening the Main Menu

4. Use the HPT scroll knob or the GSL scroll wheel to move the red cursor to HEADER SETTINGS icon (A).
5. Press the HPT scroll knob or GSL SELECT button to display the SET-UP HEADER menu list.

NOTE:

The F4 shortcut button on the operator's console also will display the SET-UP HEADER menu list.

6. Scroll to HEADER LOWER/RAISE menu item (B), and press SELECT. A menu for adjusting header lower/raise rates opens with the last header setting as the default starting point.

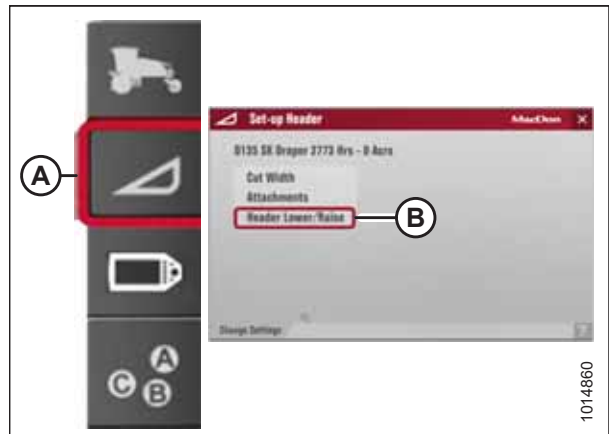

Figure 4.258: Header Settings Icon and Set-Up Header Menu List

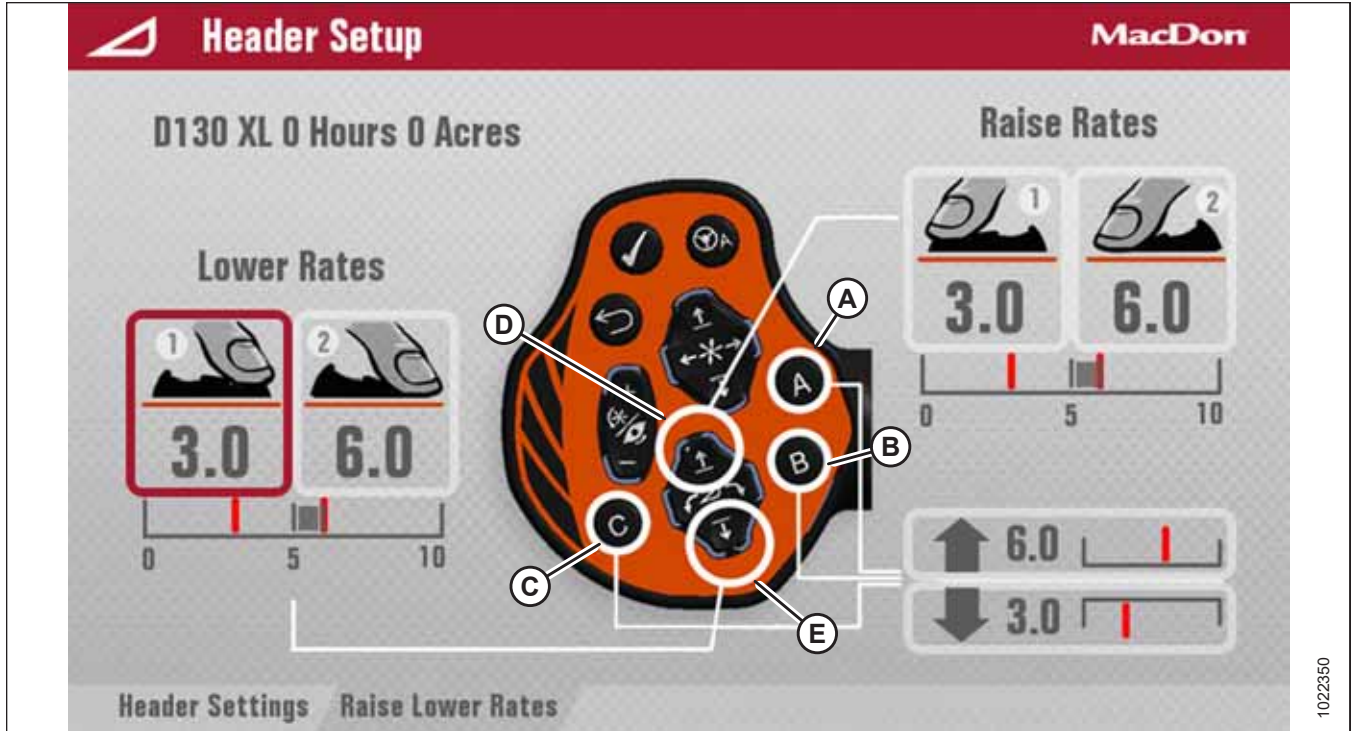

Figure 4.259: Header Raise and Lower Rates

7. The header lift/lower rate is adjustable in two stages. A half button press adjusts stage one: the slow rate, and a full button press adjusts stage two: the fast rate.

Scroll through the RAISE FIRST/RAISE SECOND and LOWER FIRST/LOWER SECOND menu selections, and program the following GSL buttons:

- HEADER RAISE (D): half press adjusts first (slow rate) stage, full press adjusts second (fast rate) stage
- HEADER LOWER (E): half press adjusts first (slow rate) stage, full press adjusts second (fast rate) stage
- ONE-TOUCH-RETURN buttons (A), (B), and (C): trigger header raise or lower presets.

4.8 Operating with D1X or D1XL Series Draper Header

For attachment instructions, refer to *Attaching D1X or D1XL Series Draper Header, page 163*.

4.8.1 Header Position

For instructions, refer to *4.7 Operating a Header, page 219* for procedures for controlling header height, header tilt, and float.

4.8.2 Adjusting Reel Fore-Aft Position

Optimize header performance based on crop type and conditions by adjusting the reel fore-aft position. The reel fore-aft position is adjusted with the multi-function switches on the ground speed lever (GSL).

1. Press and hold the switch for the desired movement; FORWARD (A) or AFT (B).

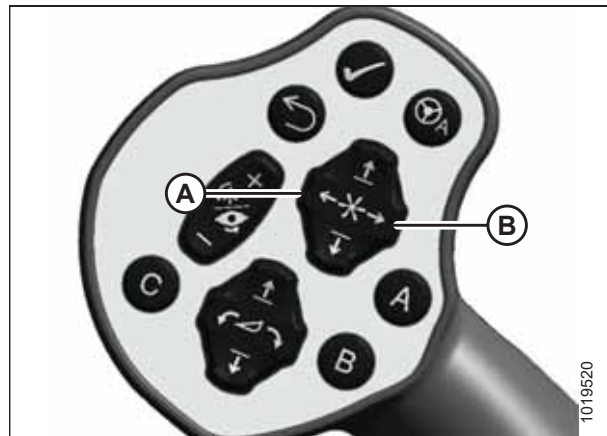

Figure 4.260: Ground Speed Lever

Settings for the fore-aft, reel height, and header height are limited as follows to prevent the reel from colliding with the cab roof:

- If reel height (C) and header height (A) are both greater than 7.0, reel fore-aft (B) will be limited to 5.0. If you try to move the reel fore-aft so the value would exceed 5.0, message (D) ("IMPORTANT: Reel position limited to prevent contacting roof") will show on the Harvest Performance Tracker (HPT) display. If you want a reel fore-aft value of greater than 5.0, lower the reel height and/or header height to a value of 7.0 or less.
- The reel fore-aft will automatically move forward to 5.0 or less under the following conditions to avoid contacting the cab roof:
 - If you increase the header height to greater than 7.0 while the reel fore-aft is greater than 5.0, and the reel height is greater than 7.0
 - If you increase the header height to greater than 7.0 while the reel fore-aft is greater than 5.0, and the reel height is greater than 7.0.

After the reel fore-aft automatically moves, you will then have to manually adjust the fore-aft.



Figure 4.261: HPT Display – Draper Header Shown

4.8.3 Adjusting Reel Height

Optimize header performance based on crop type and conditions by adjusting the reel height position. The reel height position is adjusted with the multi-function switches on the ground speed lever (GSL).

1. Press and hold the switch for the desired movement of the reel; UP (A) or DOWN (B).



Figure 4.262: Ground Speed Lever

Settings for the fore-aft, reel height, and header height are limited as follows to prevent the reel from contacting the cab roof:

- If you increase the reel height (C) to greater than 7.0 while the reel fore-aft (B) is greater than 5.0, and the header height (A) is greater than 7.0, the reel fore-aft will automatically move forward to 5.0 or less to avoid colliding with the cab roof.
- After the reel fore-aft automatically moves, you will then have to manually adjust the fore-aft.
- For instructions about operating the reel fore-aft, refer to [4.8.2 Adjusting Reel Fore-Aft Position, page 234](#).

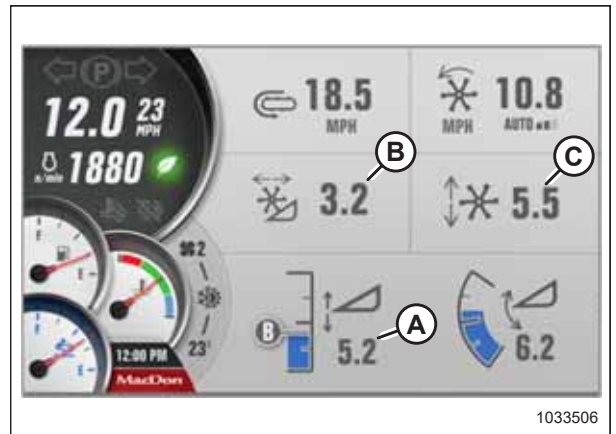

Figure 4.263: HPT Display – Draper Header Shown

4.8.4 Leveling the Header

The windrower lift linkages are factory-set to provide the proper header level, and should not normally require adjustment.

WARNING

To avoid bodily injury or death from unexpected startup of the machine, always stop the engine and remove the key from the ignition before leaving the operator's seat for any reason.

1. Press rotary scroll knob (A) on Harvest Performance Tracker (HPT) to display the QuickMenu system.
2. Rotate scroll knob (A) to highlight HEADER FLOAT symbol (B) and press scroll knob to select. The SET-UP FLOAT page displays.



Figure 4.264: HPT Display

3. Press soft key 3 (A) to remove float.



Figure 4.265: HPT Display

4. Park the windrower on level ground.
5. Press HEADER RAISE button (A) on the ground speed lever (GSL). When the header reaches maximum height, continue to hold the header raise button momentarily to allow the lift cylinders to rephase.



Figure 4.266: GSL

OPERATION

6. Lower the header to approximately 150 mm (6 in.) off the ground.
7. Ensure that channel (A) is against link (B).
8. Shut down the engine, and remove the key from the ignition.
9. Measure the distance to the ground at both ends of the header to determine if the header is level.

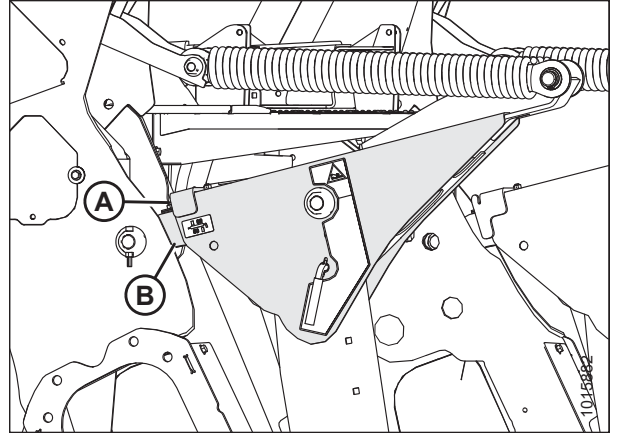

Figure 4.267: Lift Linkage

WARNING

Check to be sure all bystanders have cleared the area.

10. If adjustment is necessary, start engine and resume float. Lower the header onto the ground until channel (A) lifts away from the link (B) on both sides.
11. Shut down the engine, and remove the key from the ignition.

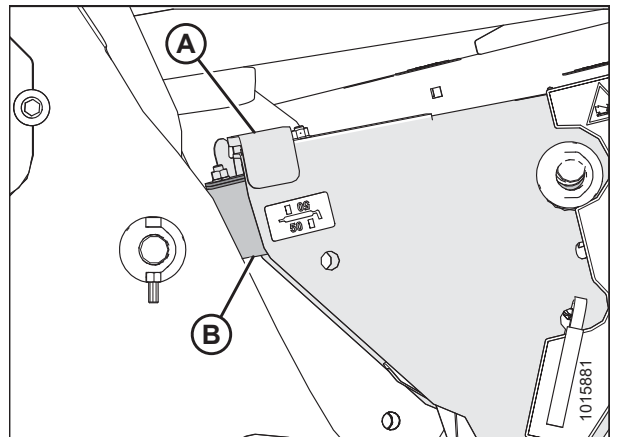

Figure 4.268: Lift Linkage

12. On the side that is higher, remove nut, washer, and bolt (A) that attaches shims (B) to the linkage.
13. Remove one or both of shims (B) and reinstall hardware (A).

WARNING

Check to be sure all bystanders have cleared the area.

14. Repeat Step 5, page 236 to Step 9, page 237 to rephase the cylinders and check the header level.
15. If additional adjustment is required, repeat Step 10, page 237 to Step 13, page 237, and install one of the removed shims on the opposite linkage.
16. Reset the header float. For instructions, refer to *Setting the Float*, page 222.

NOTE:

Additional shims are available from your Dealer.

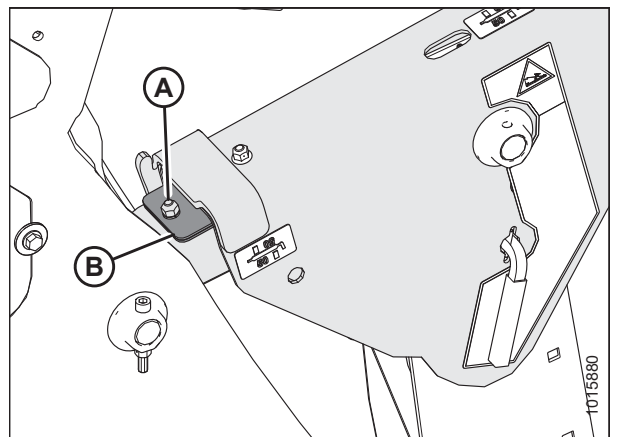

Figure 4.269: Lift Linkage Shims

4.8.5 Adjusting Reel Speed

Reel speed is displayed in either rpm, mph, or km/h (depending on the global units selection). The default reel speed is 60 rpm and can be set to auto or manual mode.

- **AUTO mode:** Minimum reel speed and operating reel speed differential relative to ground speed are set, and reel speed is maintained relative to ground speed. For instructions, refer to [Setting Reel Speed in Auto Mode, page 238](#).
- **MANUAL mode:** Reel speed is set and is maintained regardless of ground speed. For instructions, refer to [Setting Reel Speed in Manual Mode, page 240](#).

NOTE:

Both speed modes work with the One-Touch-Return feature. For example, button A on the GSL can be set for MANUAL mode and button B can be set for AUTO mode. For instructions, refer to [One-Touch-Return Buttons \(A, B, C\), page 74](#).

Setting Reel Speed in Auto Mode

This adjustment requires the header to be in operation.

1. If RUN SCREEN 1 is not already displayed, press soft key 1 (A) on the Harvest Performance Tracker (HPT) to display draper RUN SCREEN 1.



Figure 4.270: Header Run Screen 1

2. Press scroll knob (A) on the Harvest Performance Tracker (HPT) or SELECT button (B) on the ground speed lever (GSL) to display the QuickMenu system.



Figure 4.271: HPT Scroll Knob and GSL Select Button

OPERATION

- Turn knob to scroll to REEL setting (A) on the QuickMenu, and press knob to select it. The next page opens.

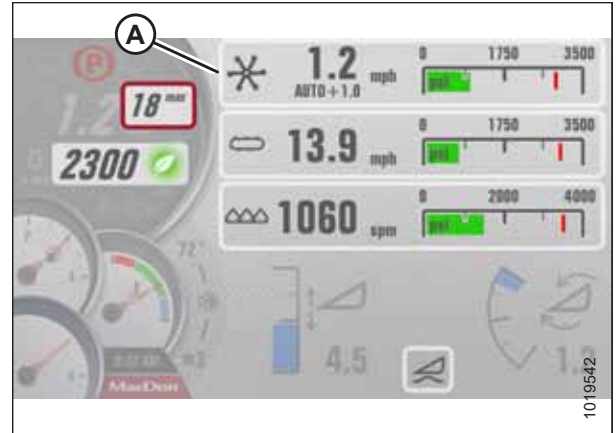

Figure 4.272: Header QuickMenu

- Scroll to mode field (A) and select it.
- Scroll in pop-up window to AUTO and select it.

NOTE:

In AUTO mode, the speed is displayed in km/h or mph (B) which cannot be changed.

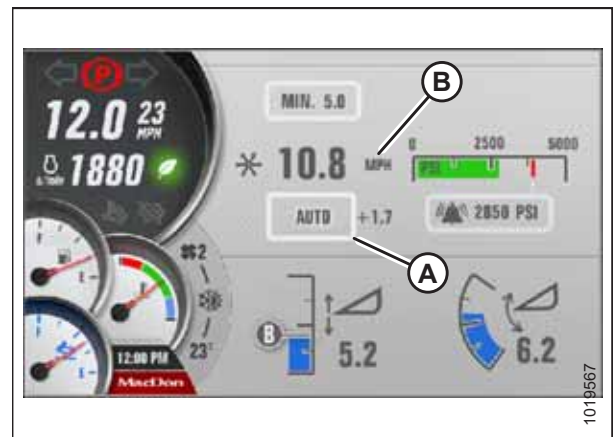

Figure 4.273: Draper Header Reel Page

- Scroll to and select MINIMUM REEL SPEED setting (A) (this setting is grayed out in manual mode).
- Turn scroll knob to adjust reel minimum speed to 1.6–8 km/h (1–5 mph) with 5 km/h (3.0 mph) as the default. Press scroll knob to select desired setting.
- Scroll to INDEX value (C) and select it.
- Turn scroll knob to set index value. The index range is +/- 8 km/h (5 mph) (zero, that is equal to ground speed, is the default). Press scroll knob to select desired setting.

NOTE:

The reel operates at reel minimum speed when the ground speed is less than the set minimum speed. Minimum reel speed is displayed (A) and MIN will replace the AUTO (B) +1.7 (C).

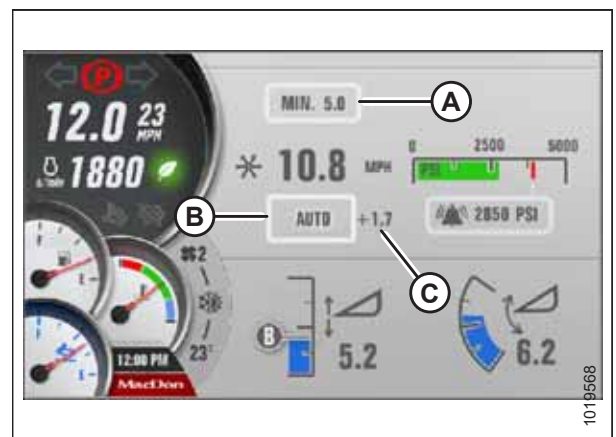

Figure 4.274: Draper Header Reel Page

OPERATION

Setting Reel Speed in Manual Mode

This adjustment requires the header to be in operation.

1. If RUN SCREEN 1 is not already displayed, press soft key 1 (A) on the Harvest Performance Tracker (HPT) to display draper RUN SCREEN 1.



Figure 4.275: Header Run Screen 1

2. Press scroll knob (A) or SELECT button (B) on the ground speed lever (GSL) to display the QUICKMENU PAGE.



Figure 4.276: HPT and GSL

3. Turn knob to scroll to REEL setting (A) on QuickMenu, and press knob to select it. The next page opens.

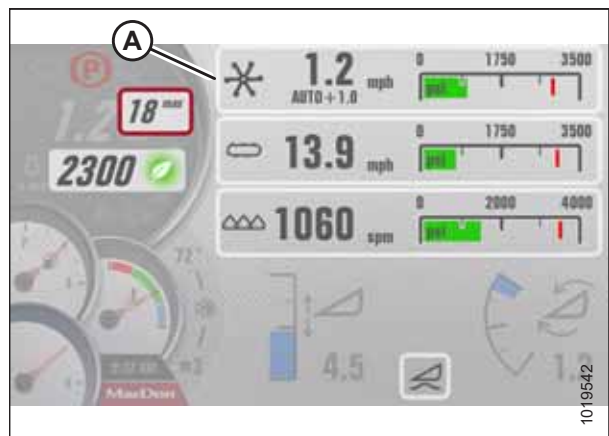

Figure 4.277: Header QuickMenu

OPERATION

4. Turn scroll knob to mode window (A) and press scroll knob to select it.
5. Scroll in pop-up window to MANUAL and press scroll knob to select it.
6. Scroll to units (B) and select desired unit (rpm, mph, or km/h).
7. Proceed to next step to adjust reel speed (C).



Figure 4.278: Draper Header Reel Page

8. Use reel speed switches (A) on GSL to set reel speed. The desired speed increases 1 rpm (or 0.1 mph or 0.2 km/h) per momentary press, or continuous scrolling if switch is pressed and held.

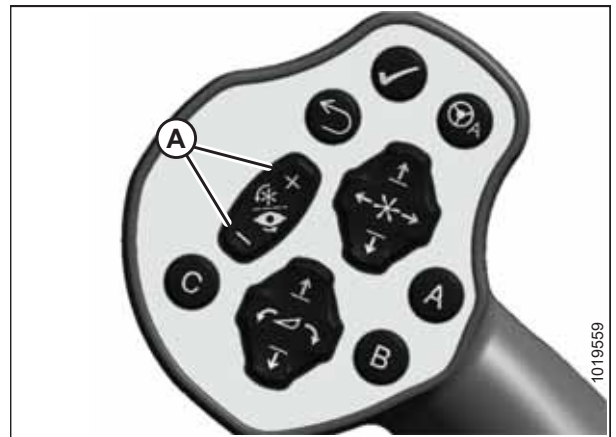

Figure 4.279: GSL

Adjusting Reel Alarm Pressure

Adjusting the reel alarm allows the operator to set an alert to inform them that the reel is operating above the desired pressure. A lower setting will cause the alarm to be set off more often; a higher setting will allow the alarm to be set off less frequently. This adjustment requires the header to be in operation.

1. If RUN SCREEN 1 is not already displayed, press soft key 1 (A) on the Harvest Performance Tracker (HPT) to display draper RUN SCREEN 1.



Figure 4.280: Header Run Screen 1

OPERATION

- Press scroll knob (A) on the Harvest Performance Tracker (HPT) or SELECT button (B) on the ground speed lever (GSL) to display the QuickMenu system.

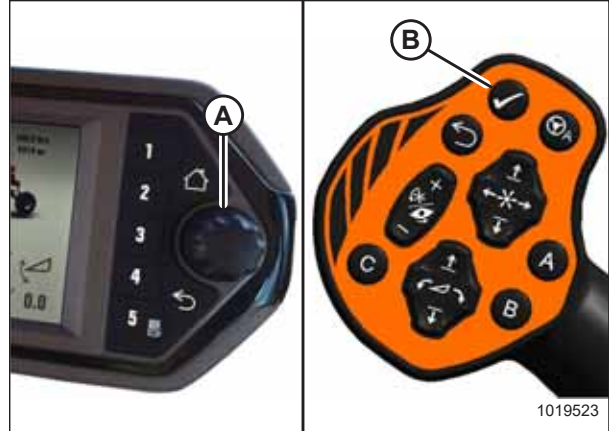

Figure 4.281: HPT Scroll Knob and GSL Select Button

- Turn knob to scroll to REEL setting (A) on QuickMenu, and press knob to select it. The next page opens.

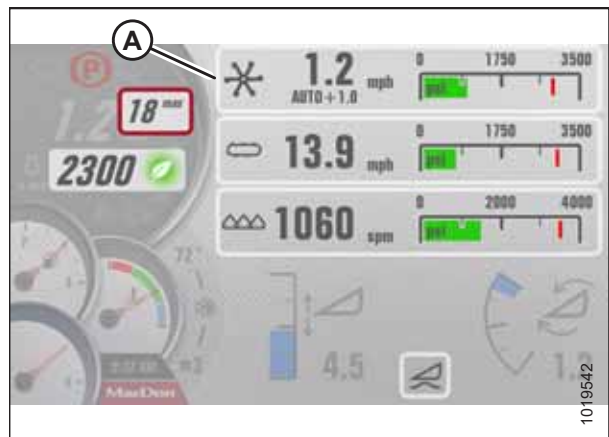

Figure 4.282: Header QuickMenu

- Turn scroll knob to highlight reel pressure ALARM (A), and press knob to select it.
- Turn knob to change the ALARM set-point in window (A). Scrolling past the highest setting turns the alarm off. When the alarm point is off, the digital value is replaced with three dashed lines.
- Adjust reel alarm pressure set-point to desired value, and press knob to select it. Factory setting is 19,995 kpa (2900 psi).

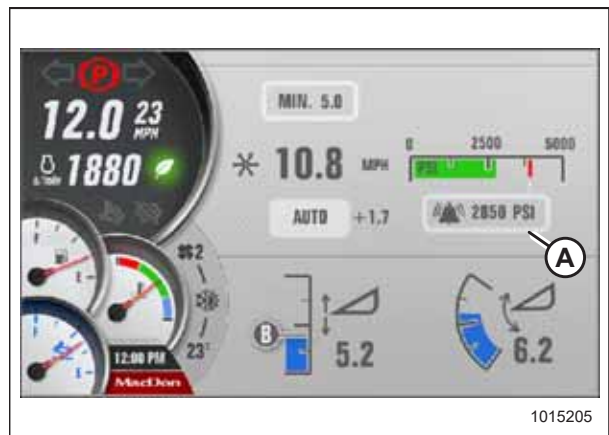

Figure 4.283: Draper Header Reel Page

4.8.6 Adjusting Draper Speed

Draper speed is displayed in mph or km/h (depending on the global units selection); the default is rpm, and can be set to auto or manual mode.

- AUTO mode: Draper speed is maintained relative to ground speed. For instructions, refer to *Setting Draper Speed in Auto Mode, page 243*.
- MANUAL mode: Draper speed is manually set and is maintained independently of ground speed. For instructions, refer to *Setting Draper Speed in Manual Mode, page 245*.

NOTE:

Both speed modes work with the One-Touch-Return feature. For example, button A on the GSL can be set for MANUAL mode and button B can be set for AUTO mode. For instructions, refer to *One-Touch-Return Buttons (A, B, C), page 74*.

Setting Draper Speed in Auto Mode

This adjustment requires the header to be in operation.

1. If RUN SCREEN 1 is not already displayed, press soft key 1 (A) on the Harvest Performance Tracker (HPT) to display draper RUN SCREEN 1.



Figure 4.284: Header Run Screen 1

2. Press scroll knob (A) on the Harvest Performance Tracker (HPT) or SELECT button (B) on the ground speed lever (GSL) while in any run screen to display the QuickMenu system.

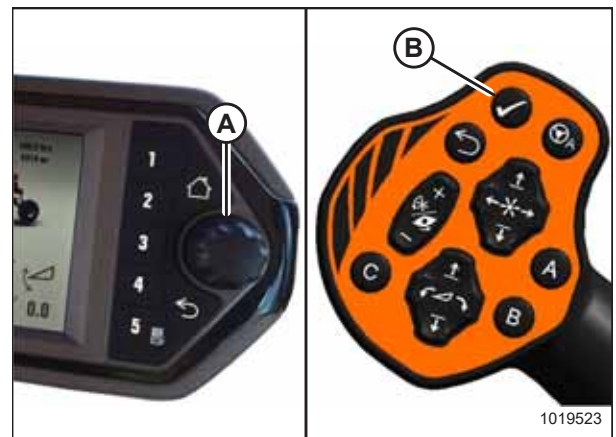

Figure 4.285: HPT Scroll Knob and GSL Select Button

OPERATION

- Turn knob and scroll to DRAPER setting (A) on the QuickMenu, and press the knob to select it. The next page opens.

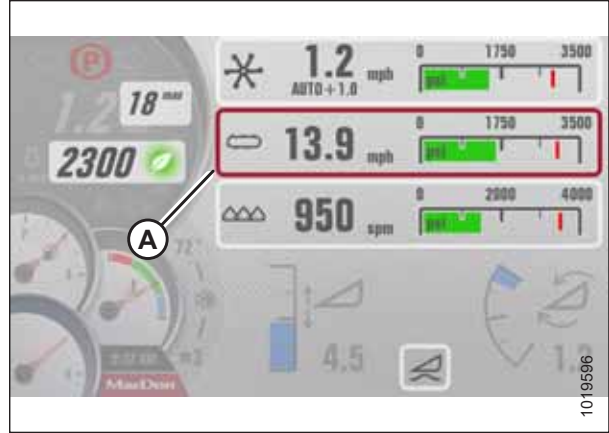

Figure 4.286: Header QuickMenu

- Scroll to mode window (A) and select it.
- Scroll in pop-up window to AUTO and select it.

NOTE:

In AUTO mode, the speed is displayed in km/h or mph (B).

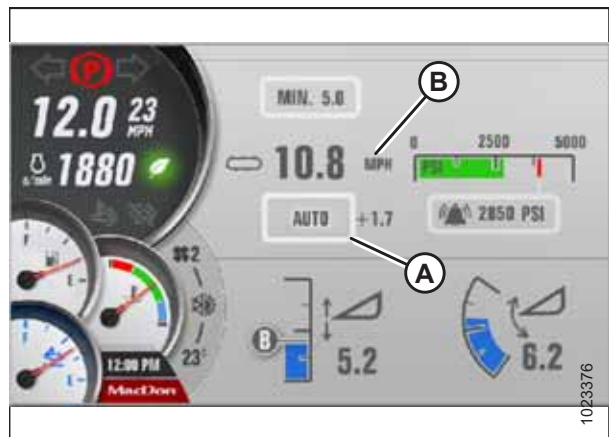

Figure 4.287: Draper Header Draper Page

- Scroll to and select MINIMUM DRAPER SPEED setting (A) (this setting is grayed out in manual mode).
- Turn the scroll knob to adjust draper minimum speed to 1.6–8 km/h (1–5 mph) with 5 km/h (3.0 mph) as the default). Press knob to select desired setting.
- Scroll to INDEX value (C) and select it.
- Turn the scroll knob to set index value. The index range is +/- 8 km/h (5 mph) (zero, i.e. equal to ground speed, is the default). Press knob to select desired setting.

NOTE:

The draper operates at MINIMUM SPEED when the ground speed + the reel index value is less than the set minimum speed. Minimum reel speed is displayed (A) and MIN will replace the AUTO +1.7 (B).

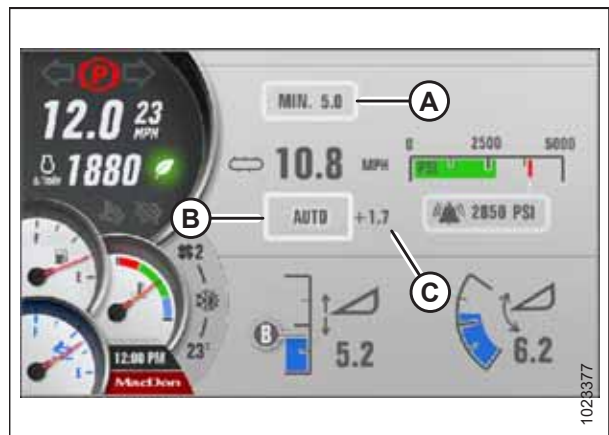

Figure 4.288: Draper Header Draper Page

OPERATION

Setting Draper Speed in Manual Mode

1. If RUN SCREEN 1 is not already displayed, press soft key 1 (A) on the Harvest Performance Tracker (HPT) to display draper RUN SCREEN 1.



Figure 4.289: Header Run Screen 1

2. Press scroll knob (A) on the Harvest Performance Tracker (HPT) or SELECT button (B) on the ground speed lever (GSL) to display the QuickMenu page.

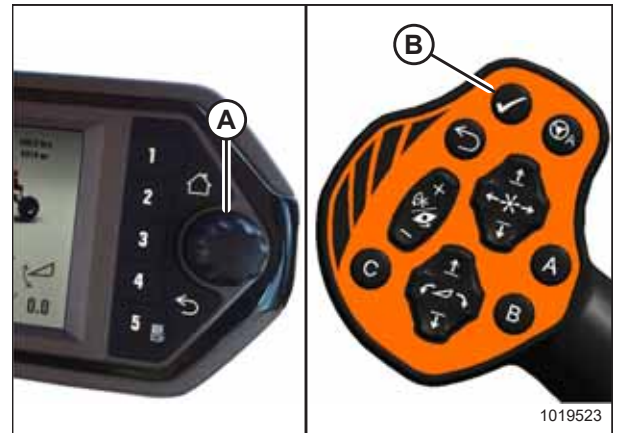

Figure 4.290: HPT Scroll Knob and GSL Select Button

3. Turn the knob to scroll to DRAPER setting (A) on QuickMenu, and press knob to select it. The next page opens.

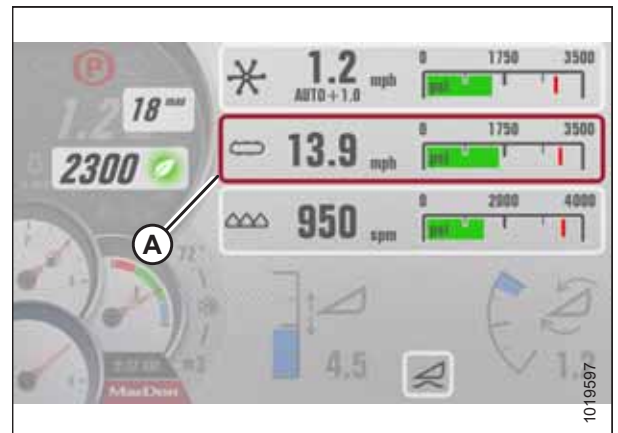

Figure 4.291: Draper Header QuickMenu

OPERATION

- Turn the scroll knob to mode window and press the scroll knob to select it.
- Scroll in the pop-up window to MANUAL (A) and press scroll knob to select it.



Figure 4.292: Draper Header Draper Page

- Set the draper speed with the console controls as follows:
 - Press and quickly release DRAPER SPEED switch (A) to increase draper speed in 0.2 km/h (0.1 mph) intervals.
 - Press and hold DRAPER SPEED switch (A) to increase draper speed in 2 km/h (1 mph) intervals.
 - Similarly decrease draper speed with switch (B).

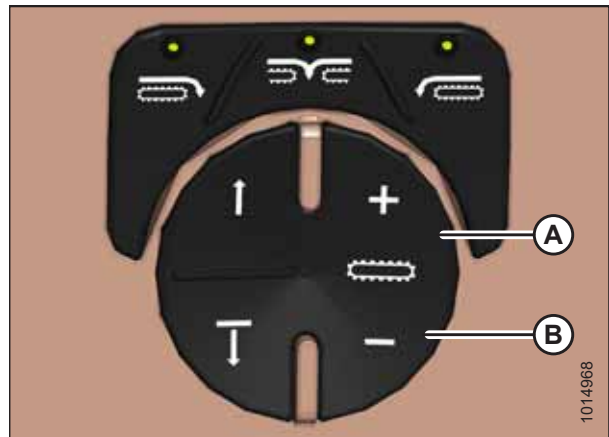

Figure 4.293: Operator's Console Draper Controls

Adjusting Draper Alarm Pressure

Adjusting the draper alarm allows the operator to set an alert to inform them that the draper is operating above the desired pressure. A lower setting will cause the alarm to be set off more often; a higher setting will allow the alarm to be set off less frequently. This adjustment requires the header to be in operation.

- If RUN SCREEN 1 is not already displayed, press soft key 1 (A) on the Harvest Performance Tracker (HPT) to display draper RUN SCREEN 1.



Figure 4.294: Header Run Screen 1

OPERATION

2. Press scroll knob (A) on the Harvest Performance Tracker (HPT) or SELECT button (B) on the ground speed lever (GSL) to display the QuickMenu page.

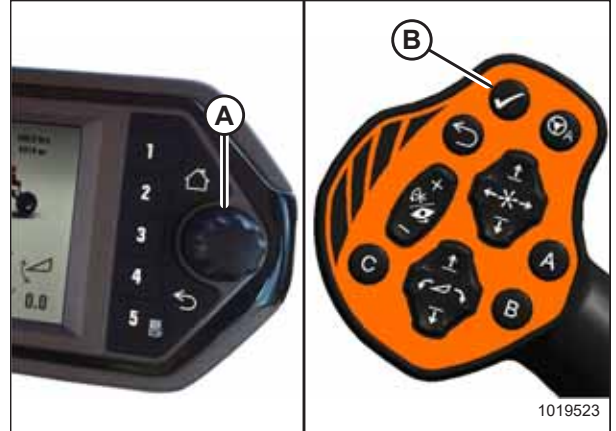

Figure 4.295: HPT Scroll Knob and GSL Select Button

3. Turn knob to scroll to DRAPER setting (A) on QuickMenu, and press knob to select it. The next page opens.



Figure 4.296: Draper Header QuickMenu

4. Scroll to DEFAULT DRAPER ALARM PRESSURE (A), and select it.
5. Change the alarm set-point by scrolling. Scrolling past the highest setting turns off the alarm. When the alarm point is off, the digital value is replaced with three dashed lines.
6. Adjust draper alarm pressure set-point to desired value, and press knob to select it. Factory setting is 19,995 kpa (2900 psi).



Figure 4.297: Draper Header Draper Page

OPERATION

Draper Slip Warning

If the left or right draper idler roller begins to slip, a warning tone will sound and one of the following messages (A) will appear on the Harvest Performance Tracker (HPT) screen:

- Left draper slipping. Disengage header.
- Right draper slipping. Disengage header.

The Operator cannot cancel the message.

IMPORTANT:

A slipping draper can severely damage the draper belts. Slippage is typically caused by debris inside the draper.

NOTE:

A draper slip sensor failure will disable the sensor and a fault will appear on the Harvest Performance Tracker (HPT) screen. Contact your MacDon Dealer for service.

NOTE:

Draper slip warning is disabled when a double draper drive kit is installed.

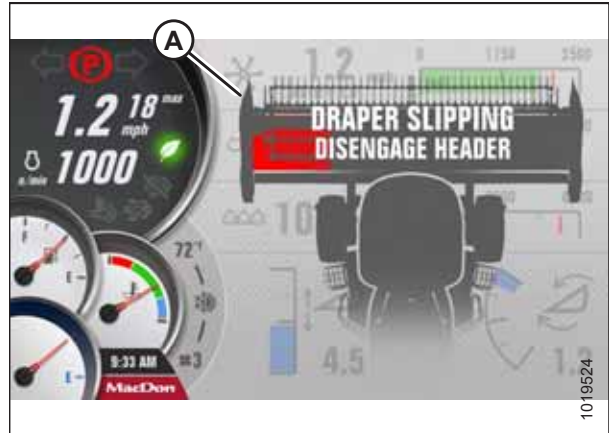

Figure 4.298: Draper Slip Warning

4.8.7 Knife Speed

The ideal cutting speed of the knife should achieve a clean cut. Crop types and conditions usually influence the knife and forward speeds.

Table 4.5 Knife Speed

Header Description		Knife Speed			
Type	Size m (ft.)	Minimum		Maximum	
		rpm ⁹	spm ¹⁰	rpm ⁹	spm ¹⁰
Draper with single knife	6.1 (20)	600	1200	700	1400
Draper with single knife	7.6 (25)	600	1200	700	1400
Draper with single knife	9.1 (30)	600	1200	700	1400
Draper with single knife	10.7 (35)	550	1100	650	1300
Draper with single knife	12.2 (40)	525	1050	600	1200
Draper with double knife	4.6 (15)	750	1500	950	1900
Draper with double knife	6.1 (20)	750	1500	950	1900
Draper with double knife	7.6 (25)	700	1400	850	1700
Draper with double knife	9.1 (30)	600	1200	800	1600
Draper with double knife	10.7 (35)	600	1200	700	1400
Draper with double knife	12.2 (40)	550	1100	700	1400
Draper with double knife	13.7 (45)	550	1100	700	1400

When the header is first attached to the windrower, the Harvest Performance Tracker (HPT) receives a code from the header that determines the knife speed range and the minimum speed.

The desired speed can be programmed and stored in the HPT so the knife will operate at the original set-point after the header is detached and reattached to the windrower.

Refer to the header operator’s manual for the suggested knife speed for a variety of crops and conditions.

NOTE:

The knife speed cannot be programmed outside the range specified for each header.

9. Revolutions per minute is the speed of knife drive box pulley

10. Strokes per minute of knife (rpm x 2)

Setting Knife Speed

Knife speed is displayed in strokes per minute (spm).

WARNING

Check to be sure all bystanders have cleared the area.

1. If RUN SCREEN 1 is not already displayed, press soft key 1 (A) on the Harvest Performance Tracker (HPT) to display draper RUN SCREEN 1.



Figure 4.299: Header Run Screen 1

2. Press scroll knob (A) on the HPT or SELECT button (B) on the ground speed lever (GSL) to display the QuickMenu page.

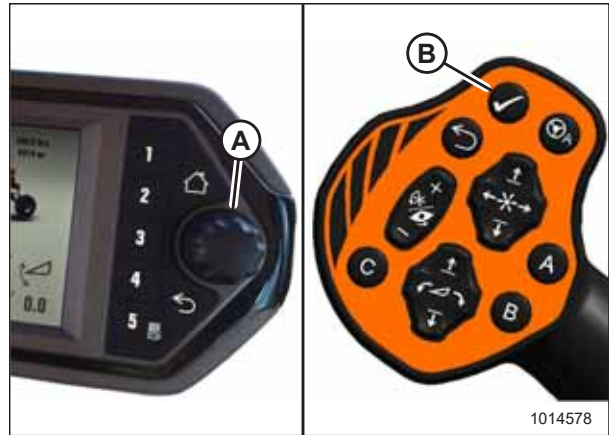

Figure 4.300: HPT Scroll Knob and GSL Select Button

3. Scroll to KNIFE setting (A) on the QuickMenu page, and select it.



Figure 4.301: Draper Header QuickMenu

OPERATION

4. Scroll to and select KNIFE SPEED setting (A).
5. Adjust the knife speed using the HPT scroll knob.
6. Press the scroll knob to select.

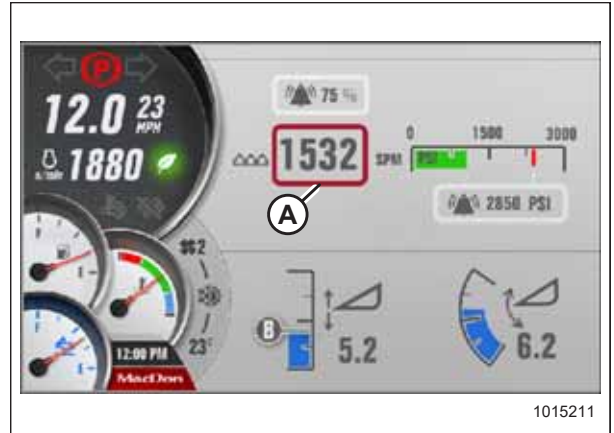

Figure 4.302: Setting Knife Speed

Adjusting Knife Alarm Pressure – Draper Header

Adjusting the knife alarm allows the operator to set an alert to inform them that the knife is operating above the desired pressure. A lower setting will cause the alarm to be set off more often; a higher setting will allow the alarm to be set off less frequently. This adjustment requires the header to be in operation.

1. If RUN SCREEN 1 is not already displayed, press soft key 1 (A) on the Harvest Performance Tracker (HPT) to display draper RUN SCREEN 1.



Figure 4.303: Header Run Screen 1

2. Press scroll knob (A) on the HPT, or SELECT button (B) on the ground speed lever (GSL) to display the QuickMenu page.

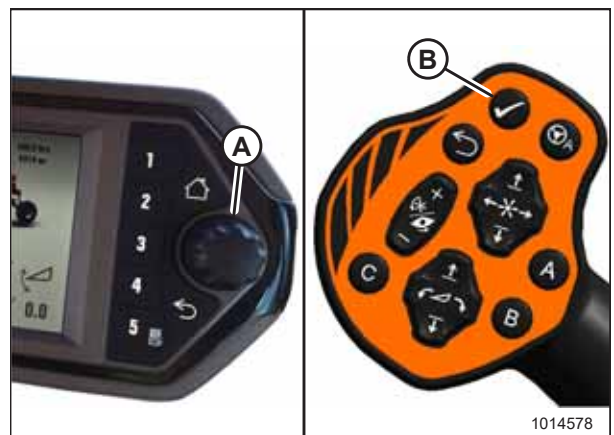

Figure 4.304: HPT Scroll Knob and GSL Select Button

OPERATION

- Turn knob to scroll to KNIFE setting (A) on the QuickMenu page, and press knob to select it.

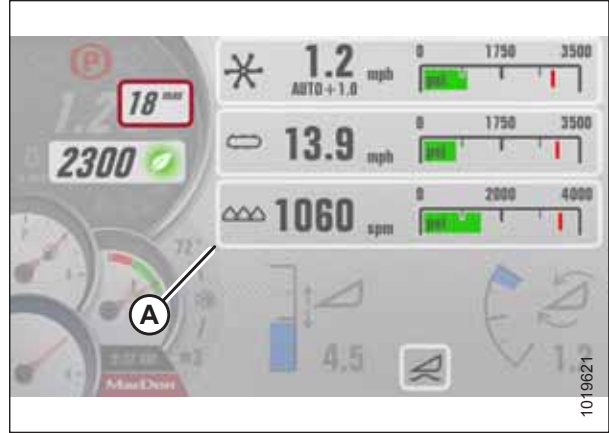

Figure 4.305: Draper Header QuickMenu

- Scroll to knife alarm pressure setting (A), and press knob to select it.
- Turn the knob to change the ALARM set-point in window (A). Scrolling past the highest setting turns the alarm off. When the alarm point is off, the digital value is replaced with three dashed lines.
- Adjust knife alarm pressure set-point to desired value, and press knob to select it. The factory setting is 23,442 kpa (3400 psi).

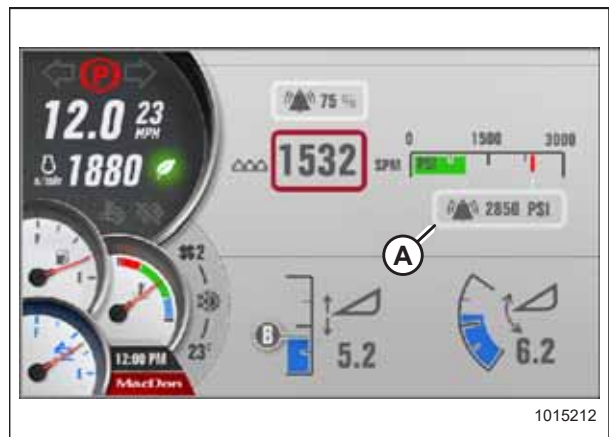

Figure 4.306: Adjusting Knife Alarm Pressure

Adjusting Knife Speed Alarm

The knife speed alarm informs the operator when knife speed is outside the desired range. A lower setting will cause the alarm to be set off less often; a higher setting will cause the alarm to be set off more frequently. The header must be in operation for this adjustment.

- If RUN SCREEN 1 is not already displayed, press soft key 1 (A) on the Harvest Performance Tracker (HPT) to display draper RUN SCREEN 1.



Figure 4.307: Header Run Screen 1

OPERATION

2. Press scroll knob (A) on the HPT or SELECT button (B) on the ground speed lever (GSL) to display the QuickMenu system.

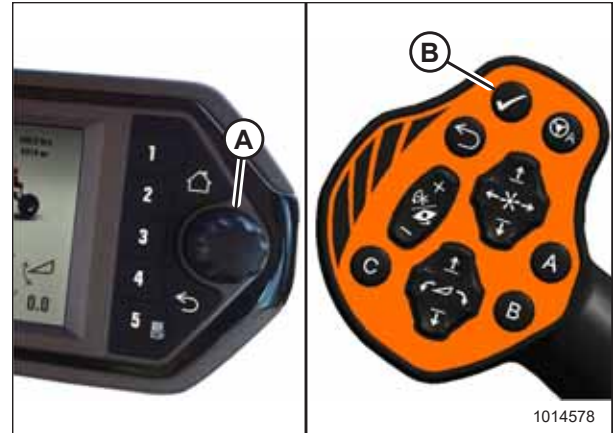

Figure 4.308: HPT Scroll Knob and GSL Select Button

3. Turn the knob to scroll to KNIFE setting (A) on the QuickMenu page, and press the knob to select it.



Figure 4.309: Draper Header QuickMenu

4. Scroll to and select KNIFE SPEED ALARM setting (A).
5. Turn scroll knob to adjust knife speed alarm as desired. Default is 70% and minimum value is 50%. For example, at a setting of 75%, an alarm will sound when knife speed decreases to 75% of preset knife speed due to overload.

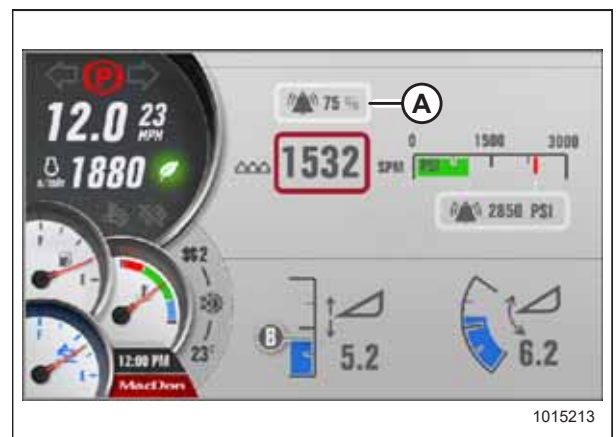

Figure 4.310: Adjusting Knife Speed Alarm

4.8.8 Deck Shift Control

When connected to a draper header with the deck shift option, hydraulic deck shift control allows you to select the deck position and draper rotation of the header from the operator's station. Deck shift allows you to select crop delivery from the left side, center, or right side of the header.

Shifting Decks

⚠ WARNING

Check to be sure all bystanders have cleared the area.

Shift decks as follows:

1. Engage header by pushing and holding HEADER ENGAGE switch (A) down, and pulling up on collar (B).



Figure 4.311: Header Engage Switch

2. Push the HEADER DECK SHIFT switch to the desired delivery position. Deck(s) will move and direction of drapers will change accordingly.

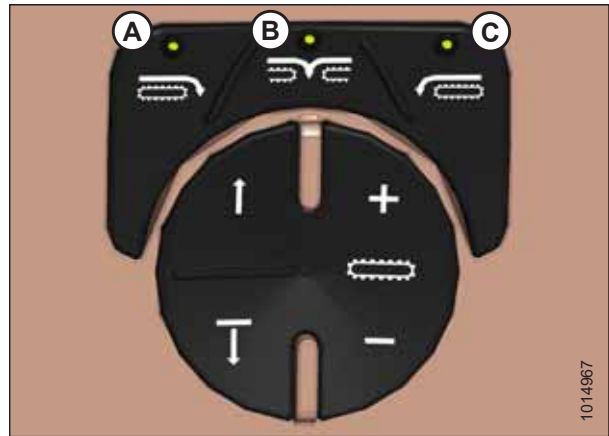

Figure 4.312: Header Deck Shift Switches

A - Right-Side Delivery
C - Left-Side Delivery

B - Center Delivery

OPERATION

Setting Float Options with Deck Shift

Header float should be set for each deck position. To program a float setting for each of the deck shift positions, follow these steps:

WARNING

Check to be sure all bystanders have cleared the area.

1. Start the engine, and use HEADER TILT switches (A) and (B) on the ground speed lever (GSL) to set header tilt to the mid-range position.

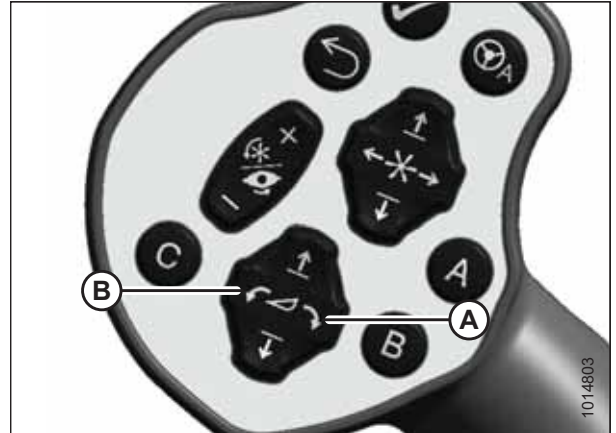

Figure 4.313: GSL

2. Engage the header by pushing and holding HEADER ENGAGE switch (A) down, and pulling up on collar (B).



Figure 4.314: Header Engage Switch

3. Select one of the following deck positions using the DECK SHIFT switches on the operator's console:
 - Right-side delivery (A)
 - Center delivery (B)
 - Left-side delivery (C)

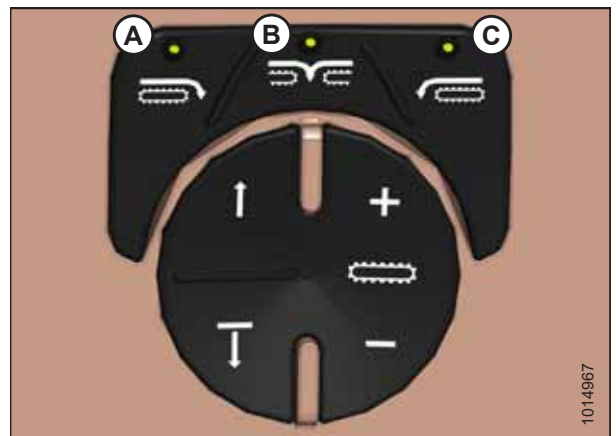

Figure 4.315: Header Deck Shift Switches

OPERATION

4. After the deck(s) have stopped moving, disengage the header with HEADER ENGAGE switch (A).
5. To adjust the float setting for the selected deck position refer to [Setting the Float, page 222](#).
6. Repeat above procedure for the other deck positions.



Figure 4.316: Header Engage Switch

4.8.9 Draper Header Run Screens

Two draper header specific run screens are viewable when operating the windrower with a draper header attached. The screens are accessed by pressing the applicable soft keys on the Harvest Performance Tracker (HPT).

1. Press soft key 1 (A) to access RUN SCREEN 1.
2. Press soft key 2 (B) to access RUN SCREEN 2.



Figure 4.317: Harvest Performance Tracker

OPERATION

Run Screen 1

This is what Run Screen 1 looks like when operating a draper header.

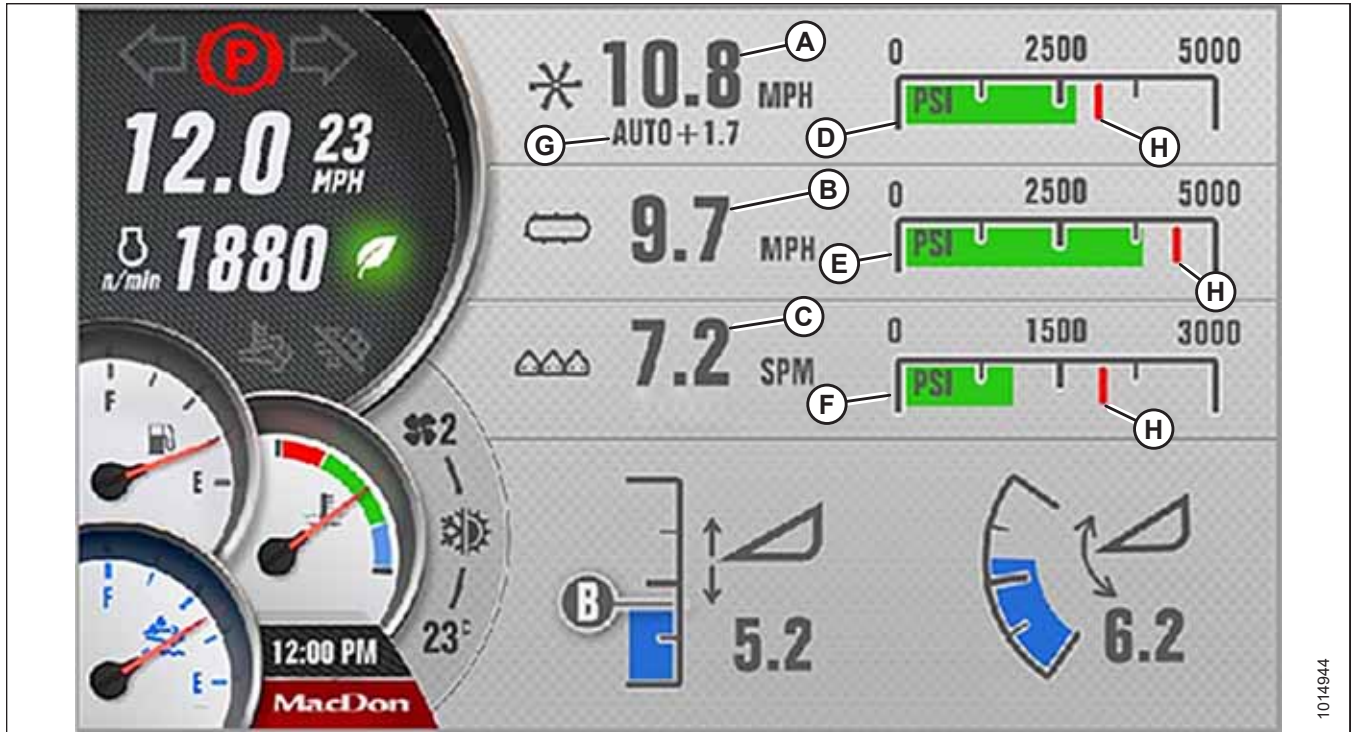

Figure 4.318: Run Screen 1 – Draper Header Display

- | | | |
|-------------------|---------------------|--------------------|
| A - Reel Speed | B - Draper Speed | C - Knife Speed |
| D - Reel Pressure | E - Draper Pressure | F - Knife Pressure |
| G - Indexing | H - Alarm Point | |

OPERATION

Run Screen 2

This is what Run Screen 2 looks like when operating a draper header.

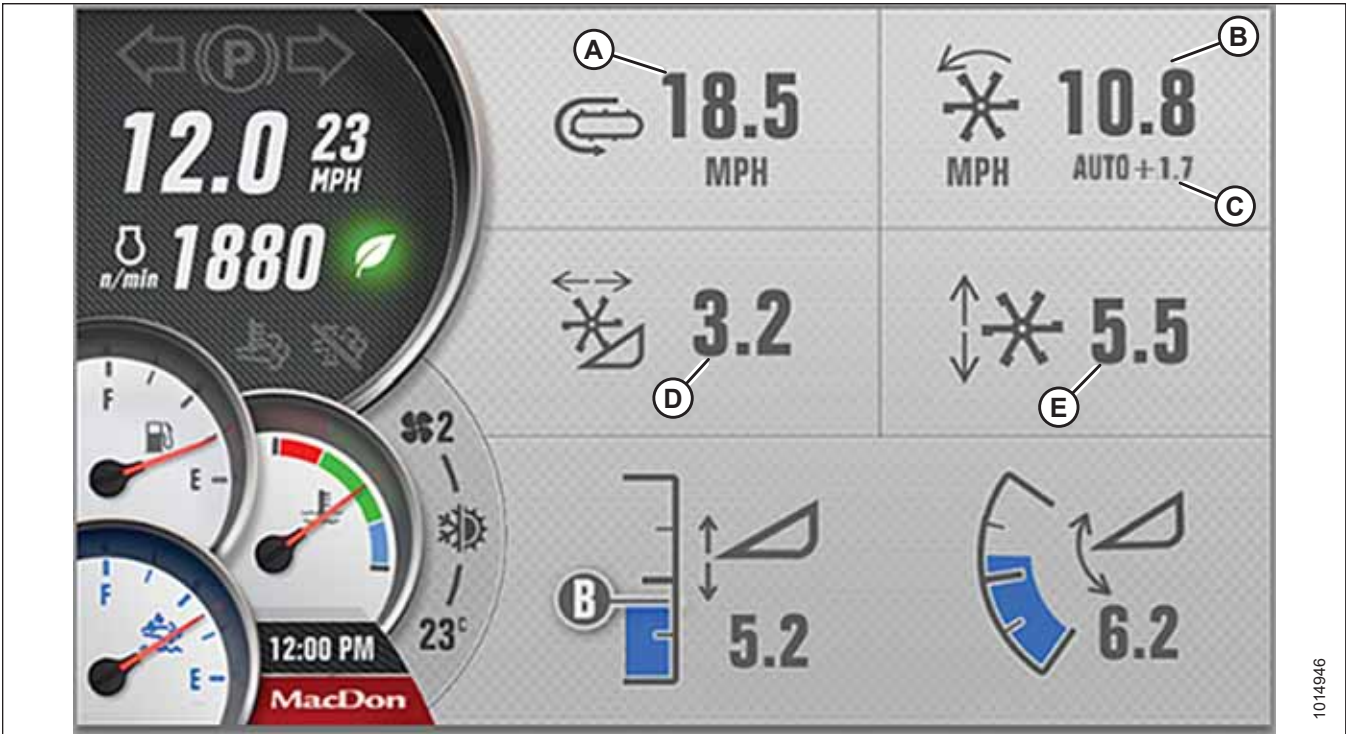

Figure 4.319: Run Screen 2 – Draper Header Display

A - Draper Speed

B - Reel Speed

C - Indexing

D - Reel Fore-Aft Position

E - Reel Height

4.8.10 Swath Compressor

The swath compressor is a large, formed polyethylene sheet designed to mount to the underside of the windrower. The swath compressor is designed for use with D1X and D1XL Series Draper Headers cutting canola.

The swath compressor shapes the windrow and anchors it into the stubble behind the header to help prevent shelling and swath damage from wind. Excessive compression by a swath compressor or roller can increase losses from crop shelling, and may increase drying time; inadequate compression can leave a windrow prone to wind damage.

Swath Compressor Controls

The following topic explains how the windrower controls the swath compressor, and describes the automated raise/lower functions.

WARNING

To avoid bodily injury or death from unexpected startup of machine, always stop engine and remove key from ignition before leaving operator's seat for any reason.

Swath compressor height (A) is displayed on the Harvest Performance Tracker (HPT) with a scale from 0–10.

Swath compressor icon (B) is displayed on the HPT when the swath compressor is activated in the attachments menu. If the sensor is disabled, height number (A) is replaced by a sensor disabled icon. For instructions on enabling the sensor, refer to the Swath Compressor for M1 Series Windrowers Setup, Operation, and Parts Manual.



Figure 4.320: HPT Display

Switches (A) and (B) on the operator's console are used to adjust the position (height). Releasing the switch stops the movement.

Each momentary press of the switch changes the value by one. Pressing and holding changes the value by one increment per second.

The last position set with the console switches becomes the target height. When an adjustment is made, the display shows the target value. The system immediately adjusts to attain the target position. After the last adjustment, the display shows target value for 5 seconds then reverts to the actual position.



Figure 4.321: Operator's Console

OPERATION

Display functions

- As the swath compressor moves up or down, target value (A) changes, windrower icon (B) appears as an outline, and swath compressor icon (C) flashes.
- Windrower icon (B) is solid when the target height is achieved.
- Value (A) is 0, and image (B) is an outline with the swath compressor fully raised.
- Icon (B) is not visible and automation is disabled without a header attached. Swath compressor height can still be adjusted.



Figure 4.322: HPT Display

OPERATION

Swath compressor automated functions: header engaged

- The swath compressor lowers to target height at a ground speed higher than 2.5 km/h (1.6 mph).
- The swath compressor fully raises as the ground speed transitions through 1.6 km/h (1 mph) during deceleration.
- The swath compressor fully raises when the header is disengaged at a ground speed higher than 1.6 km/h (1 mph).
- An IMPORTANT message to raise the swath compressor appears on the HPT accompanied by a tone when the GSL is moved out of PARK in engine-forward mode if the swath compressor is not fully raised.

Engage the swath compressor lock when the swath compressor is not in use, or when the windrower is in engine-forward mode. For instructions, refer to [Locking and Unlocking the Swath Compressor](#), page 261.

Locking and Unlocking the Swath Compressor

The swath compressor lock is located on the left cab-forward side of the swath compressor frame. When engaged, the lock prevents the compressor shield from lowering.

1. Turn lock handle (A) clockwise to engage the swath compressor lock under the following conditions:
 - Swath compressor is not in use
 - Windrower is being serviced
 - Windrower is in engine-forward mode
2. Turn handle (A) counterclockwise to disengage the lock before operating the swath compressor.

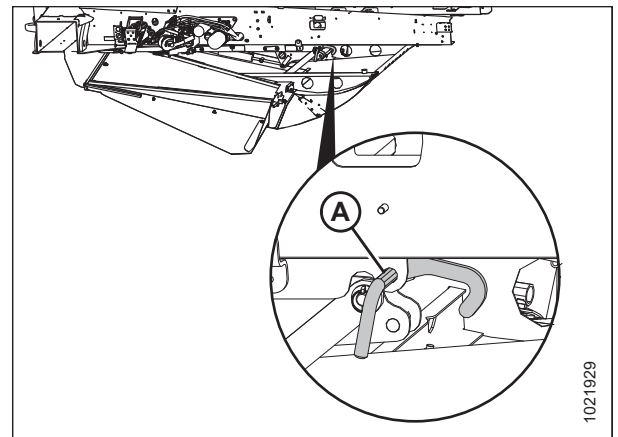

Figure 4.323: Swath Compressor Lock

4.9 Operating with an A40DX Auger Header

For attachment instructions, refer to [Attaching A40DX Auger Header, page 151](#).

4.9.1 Reel and Auger Speed

Reel speed is displayed in either rpm, mph, or km/h (depending on the global units selection). The default reel speed is 60 rpm, but it can be adjusted using either AUTO or MANUAL mode.

If the differential auger-reel control is enabled, you can adjust the auger speed separately from the reel speed. If the differential auger-reel control is not enabled, the reel and auger speeds are hydraulically linked and you cannot adjust the auger speed separately.

IMPORTANT:

Reel speed on an A40DX Auger Header **MUST NOT EXCEED** 85 rpm. Auger speed **MUST NOT EXCEED** 320 rpm.

- AUTO mode: Minimum reel speed and operating reel speed differential relative to ground speed are set, and reel speed is maintained relative to ground speed. For instructions, refer to [Setting Reel Speed in Auto Mode, page 262](#).
- MANUAL mode: Reel speed is set and is maintained regardless of ground speed. For instructions, refer to [Setting Reel Speed in Manual Mode, page 264](#).
- Differential auger-reel control engaged: Auger speed is adjusted separately from reel speed. For instructions, refer to [Setting Auger Speed, page 266](#).

NOTE:

Differential auger-reel control is a standard feature on A40DX GSS Auger Headers. If you are operating an A40DX Auger Header without the grass seed option, it is optional. Order Reel Speed Control kit (MD #B6604).

Setting Reel Speed in Auto Mode

This adjustment requires the header to be in operation.

1. If RUN SCREEN 1 is not already displayed, press soft key 1 (A) on the Harvest Performance Tracker (HPT) to display auger RUN SCREEN 1.



Figure 4.324: Header Run Screen 1

OPERATION

2. Press scroll knob (A) on the Harvest Performance Tracker (HPT) or SELECT button (B) on the ground speed lever (GSL) to display the QuickMenu system.

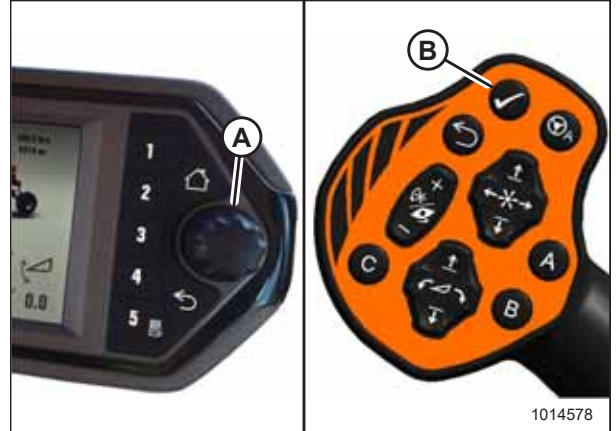

Figure 4.325: HPT Scroll Knob and GSL Select Button

3. Turn the knob to scroll to REEL setting (A) on the QuickMenu, and press the knob to select it. The next page opens.

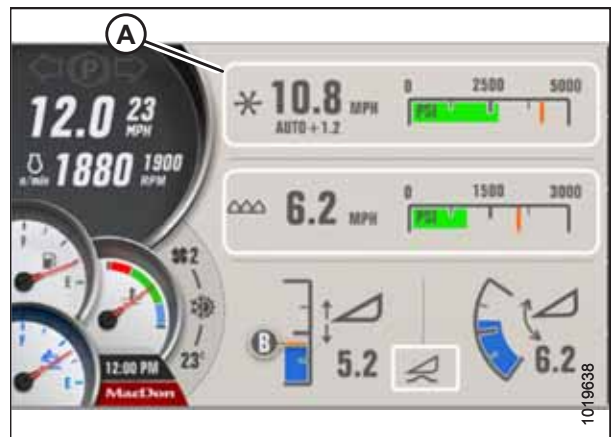

Figure 4.326: Header QuickMenu Screen

4. Scroll to mode window (A) and select it.
5. Scroll to AUTO in the pop-up window, and select it.

NOTE:

In AUTO mode, the speed is displayed in km/h or mph (B) which cannot be changed.

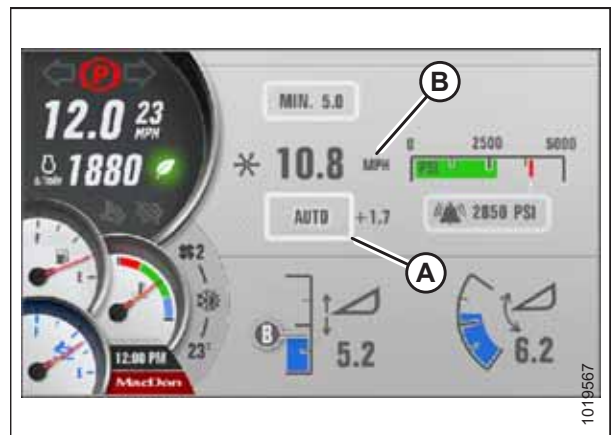

Figure 4.327: Draper Header Reel Screen

OPERATION

6. Scroll to MINIMUM REEL SPEED setting (A) and select it (this setting is grayed out in manual mode).
7. Turn the scroll knob to adjust the minimum reel speed between 0–8 km/h (5 mph). Press the knob to select the desired setting.
8. Scroll to INDEX value (C) and select it.
9. Turn the scroll knob to set the index value. The index range is +/- 8 km/h (5 mph) (zero, i.e. equal to ground speed, is the default). Press knob to select desired setting.

NOTE:

The reel operates at reel minimum speed when the ground speed is less than the set minimum speed. Minimum reel speed is displayed (A) and MIN will replace the AUTO +1.7 (B).

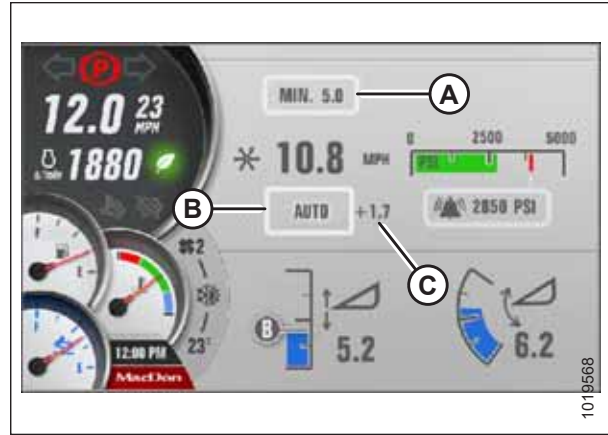

Figure 4.328: Auger Header Reel Screen

Setting Reel Speed in Manual Mode

This adjustment requires the header to be in operation.

1. If RUN SCREEN 1 is not already displayed, press soft key 1 (A) on the Harvest Performance Tracker (HPT) to display auger RUN SCREEN 1.
2. Press scroll knob (A) on the Harvest Performance Tracker (HPT) or SELECT button (B) on the ground speed lever (GSL) to display the QuickMenu system.



Figure 4.329: Header Run Screen 1



Figure 4.330: HPT Scroll Knob and GSL Select Button

OPERATION

- Turn the knob to scroll to REEL setting (A) on the QuickMenu, and press knob to select it. The next page opens.

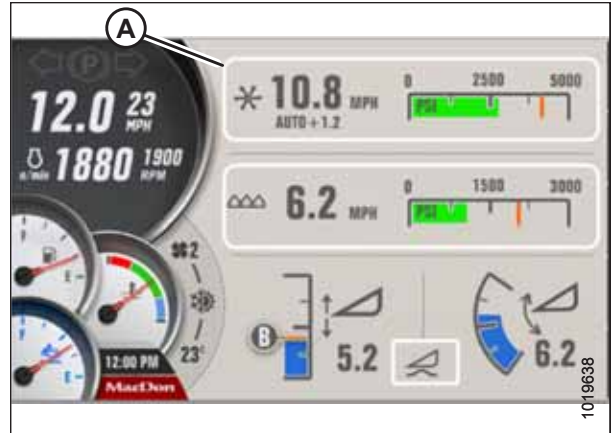

Figure 4.331: Header QuickMenu Screen

- Scroll to mode window (A) and select it.
- Scroll in pop-up window to MANUAL and select it.
- Scroll to UNITS (B) and select the desired unit (that is rpm, mph, or km/h).
- Scroll to SPEED VALUE (C) and select it.

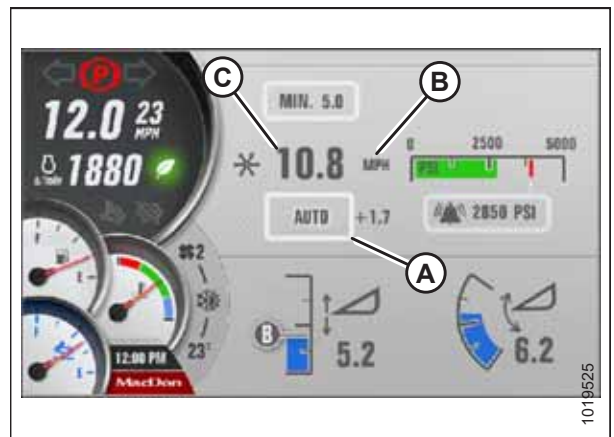

Figure 4.332: Auger Header Reel Screen

- Use REEL SPEED switches (A) on GSL to set reel speed. The desired speed increases 1 rpm (0.1 mph or 0.2 km/h) if set to mph or km/h) per momentary press, or continuous scrolling if switch is pressed and held.



Figure 4.333: GSL

OPERATION

Setting Auger Speed

The auger speed can only be adjusted independently if the differential auger-reel control is engaged. This is a standard feature on A40DX GSS Auger Headers, but an option on A40DX Auger Headers without the Grass Seed option. To acquire this option, order Reel Speed Control kit (MD #B6604) from your Dealer.

If the differential auger-reel control is not engaged, the auger speed is automatically adjusted when you adjust reel speed.

NOTE:

When the differential auger-reel control is engaged, the minimum/maximum reel speed is dependent on the auger speed. In some cases, in order to have the reel run slower or faster, you may have to decrease or increase the auger speed.

1. To adjust the auger speed, press soft key 2 on the HPT to display RUN SCREEN 2.



Figure 4.334: HPT Screen Display

2. Press scroll knob (A) on the HPT or SELECT button (B) on the ground speed lever (GSL) to display the Quick Menu system.



Figure 4.335: HPT Scroll Knob and GSL Select Button

OPERATION

3. Scroll to AUGER SPEED tile (A) and select it.



Figure 4.336: HPT Screen Display

4. AUGER SPEED (A) can now be adjusted between 150 and 340 rpm.

NOTE:

Auger speed can be displayed in rpm, mph, or km/h (depending on global units selection) and can be switched by navigating to the QuickMenu and selecting the speed symbol.



Figure 4.337: HPT Screen Display

Adjusting the Reel/Auger Alarm Pressure

Adjusting the reel/auger alarm allows the operator to set an alert to inform them that the reel is operating above the desired pressure. A lower setting will cause the alarm to be set off more often; a higher setting will allow the alarm to be set off less frequently. This adjustment requires the header to be in operation.

1. If RUN SCREEN 1 is not already displayed, press soft key 1 (A) on the Harvest Performance Tracker (HPT) to display auger RUN SCREEN 1.



Figure 4.338: Header Run Screen 1

OPERATION

2. Press scroll knob (A) on the Harvest Performance Tracker (HPT) or SELECT button (B) on the ground speed lever (GSL) to display the QuickMenu system.



Figure 4.339: HPT Scroll Knob and GSL Select Button

3. Turn the knob to scroll to REEL setting (A) on the QuickMenu, and press knob to select it. The next page opens.

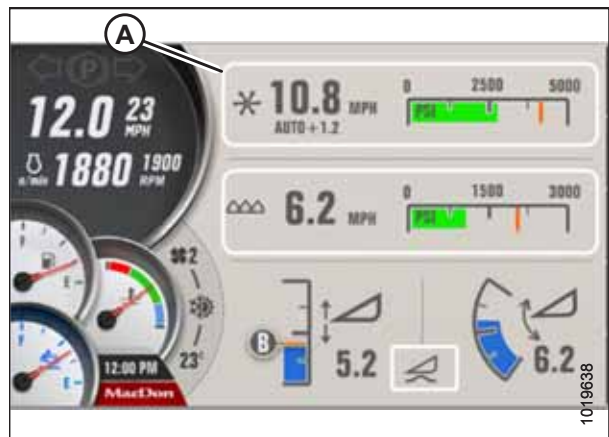

Figure 4.340: Header QuickMenu Screen

4. Turn the scroll knob to highlight reel pressure ALARM (A), and press knob to select it.
5. Turn the knob to change the ALARM set-point in window (A). Scrolling past the highest setting turns off the alarm. When the alarm point is off, the digital value is replaced with three dashed lines.
6. Adjust the reel alarm pressure set-point to the desired value, and press the knob to select it. Factory setting is 19,995 kpa (2900 psi).

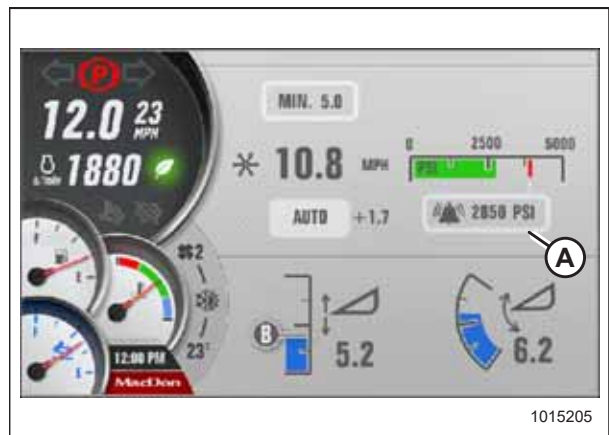

Figure 4.341: Setting Reel Alarm Pressure

4.9.2 Knife Speed

The ideal cutting speed of the knife should achieve a clean cut. Crop types and conditions usually influence the knife and forward speeds.

Table 4.6 Knife Speed Table

Header Description		Knife Speed			
Type	Size m (ft.)	Minimum		Maximum	
		rpm ¹¹	spm ¹²	rpm ¹¹	spm ¹²
Auger A40DX Grass Seed	All	700	1400	975	1950
Auger A40DX	All	700	1400	975	1950

When the header is first attached to the windrower, the Harvest Performance Tracker (HPT) receives a code from the header that determines the knife speed range and the minimum speed.

The desired speed can be programmed and stored in the HPT so the knife will operate at the original set-point after the header is detached and reattached to the windrower.

Refer to the header operator’s manual for the suggested knife speed for a variety of crops and conditions.

NOTE:

The knife speed cannot be programmed outside the range specified for each header.

Setting Knife Speed

This adjustment requires the header to be in operation.



WARNING

Check to be sure all bystanders have cleared the area.

1. If RUN SCREEN 1 is not already displayed, press soft key 1 (A) on the Harvest Performance Tracker (HPT) to display draper RUN SCREEN 1.



Figure 4.342: Auger Header Run Screen 1

11. Revolutions per minute is the speed of knife drive box pulley.
 12. Strokes per minute of knife (rpm x 2).

OPERATION

2. Press the scroll knob (A) on the Harvest Performance Tracker (HPT) or the SELECT button (B) on the ground speed lever (GSL) to display the QuickMenu system.



Figure 4.343: HPT Scroll Knob and GSL Select Button

3. Scroll to the KNIFE setting (A) on the QuickMenu screen, and select it.

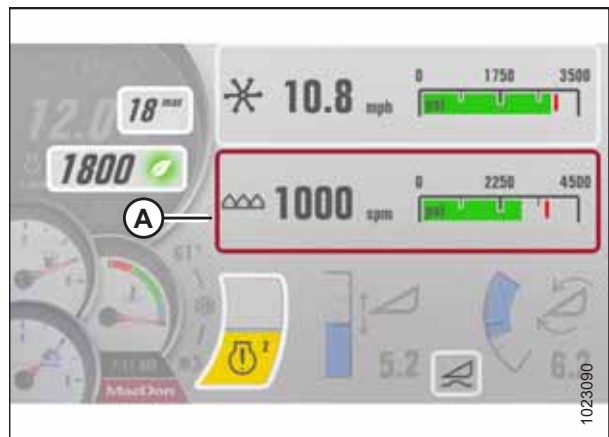

Figure 4.344: Auger Header QuickMenu Screen

4. Scroll to and select the KNIFE SPEED setting (A), displayed in strokes per minute.
5. Adjust knife speed using the HPT scroll knob.
6. Press knob to select.

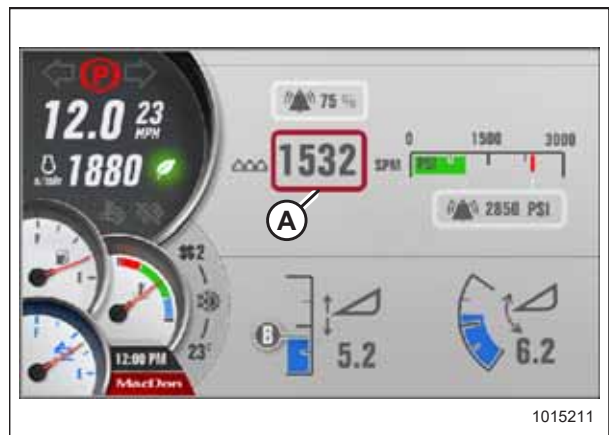

Figure 4.345: Knife Screen

OPERATION

Adjusting Knife Alarm Pressure – Auger Header

Adjusting the knife alarm allows the operator to set an alert to inform them that the knife is operating above the desired pressure. A lower setting will cause the alarm to be set off more often; a higher setting will allow the alarm to be set off less frequently. This adjustment requires the header to be in operation.

1. If RUN SCREEN 1 is not already displayed, press soft key 1 (A) on the Harvest Performance Tracker (HPT) to display auger RUN SCREEN 1.



Figure 4.346: Header Run Screen 1

2. Press scroll knob (A) on the Harvest Performance Tracker (HPT) or SELECT button (B) on the ground speed lever (GSL) to display the QuickMenu system.

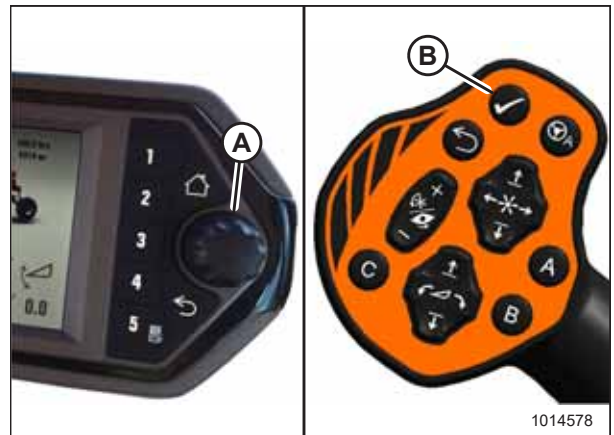

Figure 4.347: HPT Scroll Knob and GSL Select Button

3. Scroll to KNIFE ALARM PRESSURE setting (A), and use the knob to select it.
4. Turn the knob to change ALARM set-point in window (A). Scrolling past the highest setting turns the alarm off. When the alarm point is off, the digital value is replaced with three dashed lines.
5. Adjust the reel alarm pressure set-point to the desired value, and press the knob to select it. Factory setting is 24,821 kPa (3600 psi).



Figure 4.348: Knife Screen

OPERATION

Adjusting Knife Speed Alarm

This adjustment requires the header to be in operation.

1. If RUN SCREEN 1 is not already displayed, press soft key 1 (A) on the Harvest Performance Tracker (HPT) to display draper RUN SCREEN 1.



Figure 4.349: Header Run Screen 1

2. Press scroll knob (A) on the Harvest Performance Tracker (HPT) or SELECT button (B) on the ground speed lever (GSL) to display the QuickMenu system.

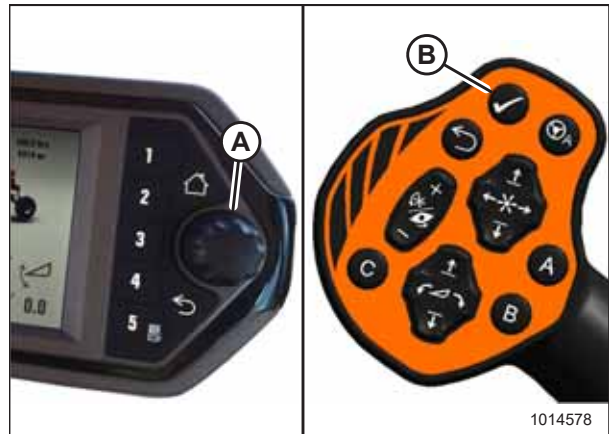

Figure 4.350: HPT Scroll Knob and GSL Select Button

3. Scroll to KNIFE setting (A) on the QuickMenu page, and select it.

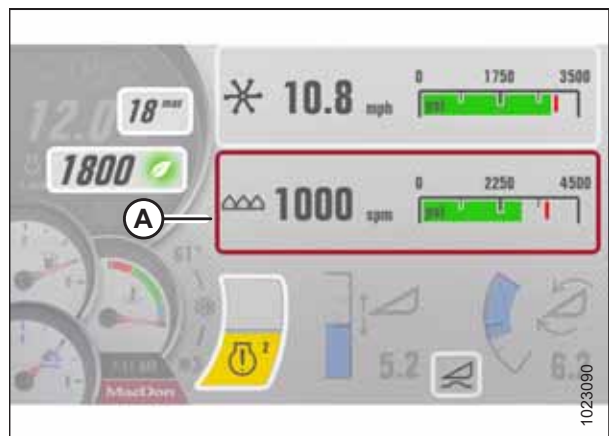

Figure 4.351: Auger Header QuickMenu Screen

OPERATION

4. Scroll to and select KNIFE SPEED ALARM setting (A), displayed as a % of the preset knife speed.
5. Adjust the knife speed alarm % as desired. Default is 70% and range is 50–90%.

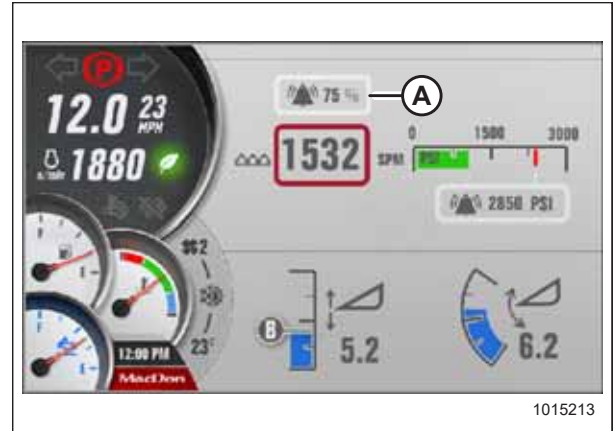

Figure 4.352: Knife Screen

4.9.3 Setting Float Options with Fixed Deck

When using an auger, the DECK SHIFT buttons can be used to store three different float settings. This is useful when cutting in varying ground conditions, or when having one side lighter is desirable (such as cutting along wheel tracks or irrigation borders).

WARNING

Check to be sure all bystanders have cleared the area.

1. Start the engine and use HEADER TILT switches (A) and (B) on the ground speed lever (GSL) to set header tilt to the mid-range position.

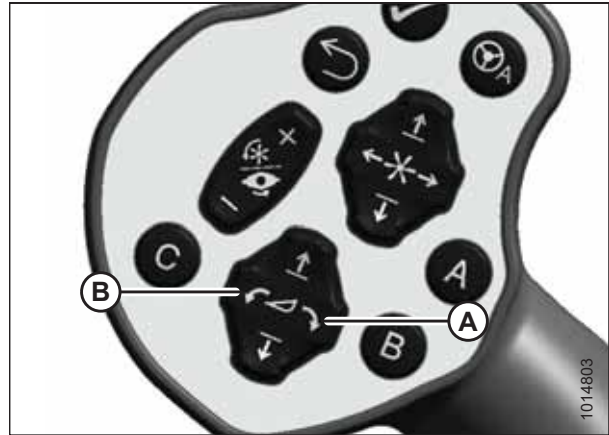

Figure 4.353: GSL

2. Engage the header by pushing and holding down HEADER ENGAGE switch (A), and pulling up on collar (B).



Figure 4.354: Header Engage Switch

OPERATION

3. Select one of the following deck positions using the DECK SHIFT switches on the operator's console:

- Right-side delivery (A)
- Center delivery (B)
- Left-side delivery (C)

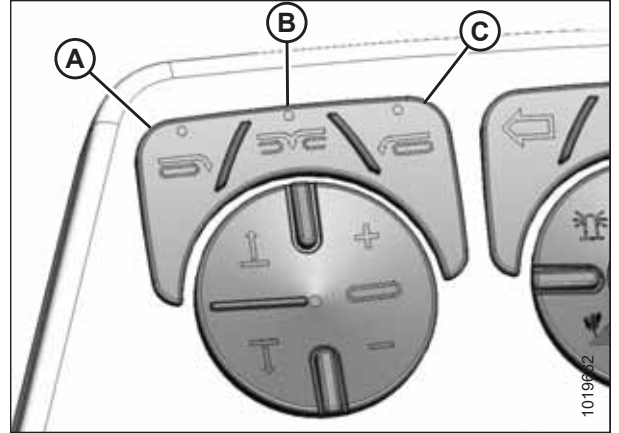

Figure 4.355: Header Deck Shift Switches

4. Disengage the header by pushing down on HEADER ENGAGE switch (A).
5. Adjust the float setting for the selected deck position. For instructions, refer to [Setting the Float, page 222](#).
6. Repeat steps for the other deck positions.



Figure 4.356: Header Engage Switch

4.9.4 Auger Header Run Screens

Two auger header specific run screens are viewable when operating windrower with an auger header attached. The screens are accessed by pressing the applicable soft keys on the Harvest Performance Tracker (HPT).

Run Screen 1

This is what Run Screen 1 looks like when operating an auger header.



Figure 4.357: Run Screen 1 – Auger Header Display

A - Reel/Auger Speed

B - Knife Speed

C - Reel/Auger Pressure

D - Knife Pressure

OPERATION

Run Screen 2

This is what Run Screen 2 looks like when operating an auger header.



Figure 4.358: Run Screen 2 – Auger Header Display

A - Knife Speed
D - Index Value

B - Knife Pressure
E - Engine Load

C - Reel/Auger Speed

4.10 Operating with an R85 Rotary Disc Header

4.10.1 Setting Disc Speed

This adjustment requires the header to be in operation.

WARNING

Check to be sure all bystanders have cleared the area.

1. If RUN SCREEN 1 is not already displayed, press soft key 1 (A) on the Harvest Performance Tracker (HPT) to display RUN SCREEN 1.



Figure 4.359: Disc Header Run Screen 1

2. Press disc speed switch (A) on GSL to increase disc speed, or switch (B) to decrease speed.
3. Refer to screen (as shown in Step 1, page 278) for speed display.



Figure 4.360: GSL

4.10.2 Adjusting Disc Pressure Alarm

Adjusting the disc alarm allows the operator to set an alert to inform them that the disc is operating at a desired pressure. A lower setting will cause the alarm to be set off more often; a higher setting will allow the alarm to be set off less frequently. This adjustment requires the header to be in operation.

⚠ WARNING

Check to be sure all bystanders have cleared the area.

1. If RUN SCREEN 1 is not already displayed, press soft key 1 (A) on the Harvest Performance Tracker (HPT) to display draper RUN SCREEN 1.



Figure 4.361: Disc Header Run Screen 1

2. Press scroll knob (A) on the Harvest Performance Tracker (HPT) or SELECT button (B) on the ground speed lever (GSL) to display the QuickMenu system.

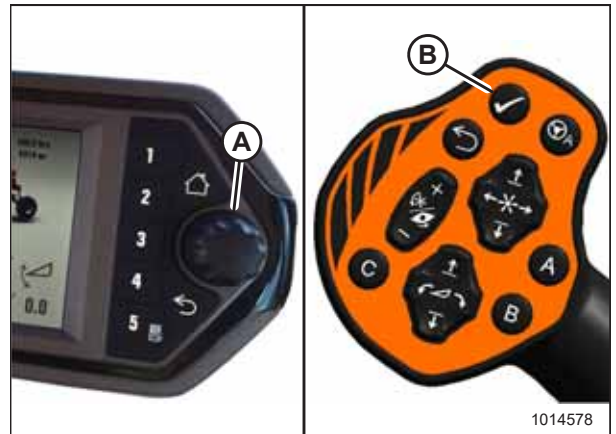

Figure 4.362: HPT Scroll Knob and GSL Select Button

OPERATION

3. Scroll to DISC SPEED setting (A) on the QuickMenu screen, and select it.

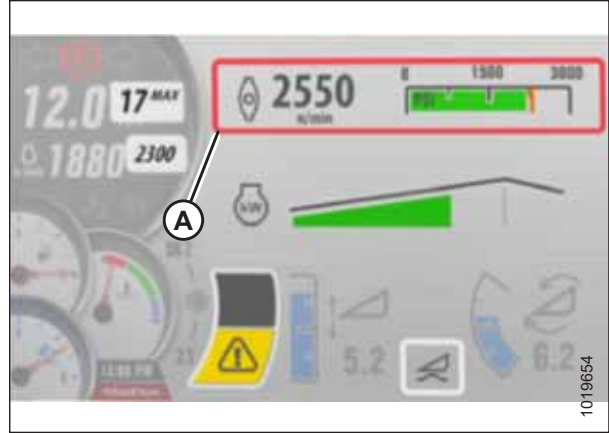

Figure 4.363: Disc Header QuickMenu Screen

4. Scroll to DISC PRESSURE ALARM setting (A), and select it.
5. Scroll to the desired alarm set-point or scroll past the highest setting to turn the alarm OFF. The digital value is replaced by three dashed lines, indicating that it is possible to adjust the alarm set-point value.
6. Adjust the disc alarm pressure set-point to desired value. Factory setting is 310 bar (4500 psi).



Figure 4.364: Disc Pressure Screen

4.10.3 Setting Float Options with Fixed Deck

When using an auger or rotary header, the DECK SHIFT buttons can be used to store three different float settings. This is useful when cutting in varying ground conditions, or when having one side lighter is desirable (such as cutting along wheel tracks or irrigation borders).

WARNING

Check to be sure all bystanders have cleared the area.

1. Start the engine and use HEADER TILT switches (A) and (B) on the ground speed lever (GSL) to set header tilt to the mid-range position.

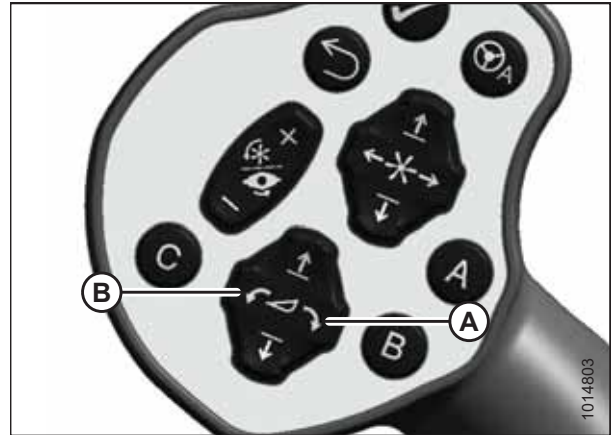

Figure 4.365: GSL

2. Engage the header by pushing and holding down HEADER ENGAGE switch (A), and pulling up on collar (B).



Figure 4.366: Header Engage Switch

OPERATION

3. Select one of the following deck positions using the DECK SHIFT switches on the operator's console:

- Right-side delivery (A)
- Center delivery (B)
- Left-side delivery (C)

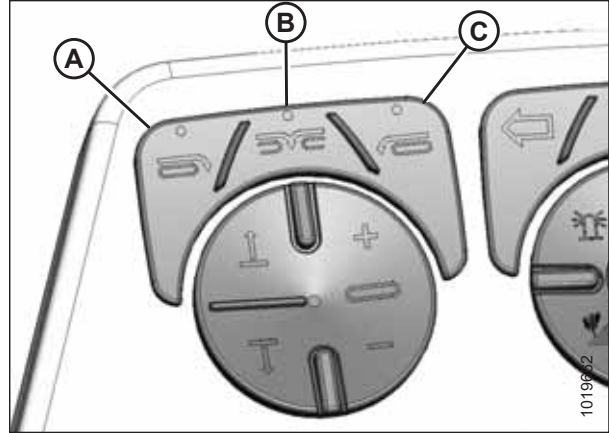

Figure 4.367: Header Deck Shift Switches

4. Disengage the header by pushing down on HEADER ENGAGE switch (A).
5. Adjust the float setting for the selected deck position. For instructions, refer to [Setting the Float, page 222](#).
6. Repeat steps for the other deck positions.



Figure 4.368: Header Engage Switch

4.10.4 Disc Header Run Screens

Two disc header specific run screens are viewable when operating windrower with an auger header attached. The screens are accessed by pressing the applicable soft keys on the Harvest Performance Tracker (HPT).

Run Screen 1

This is what Run Screen 1 looks like when operating a rotary disc header.

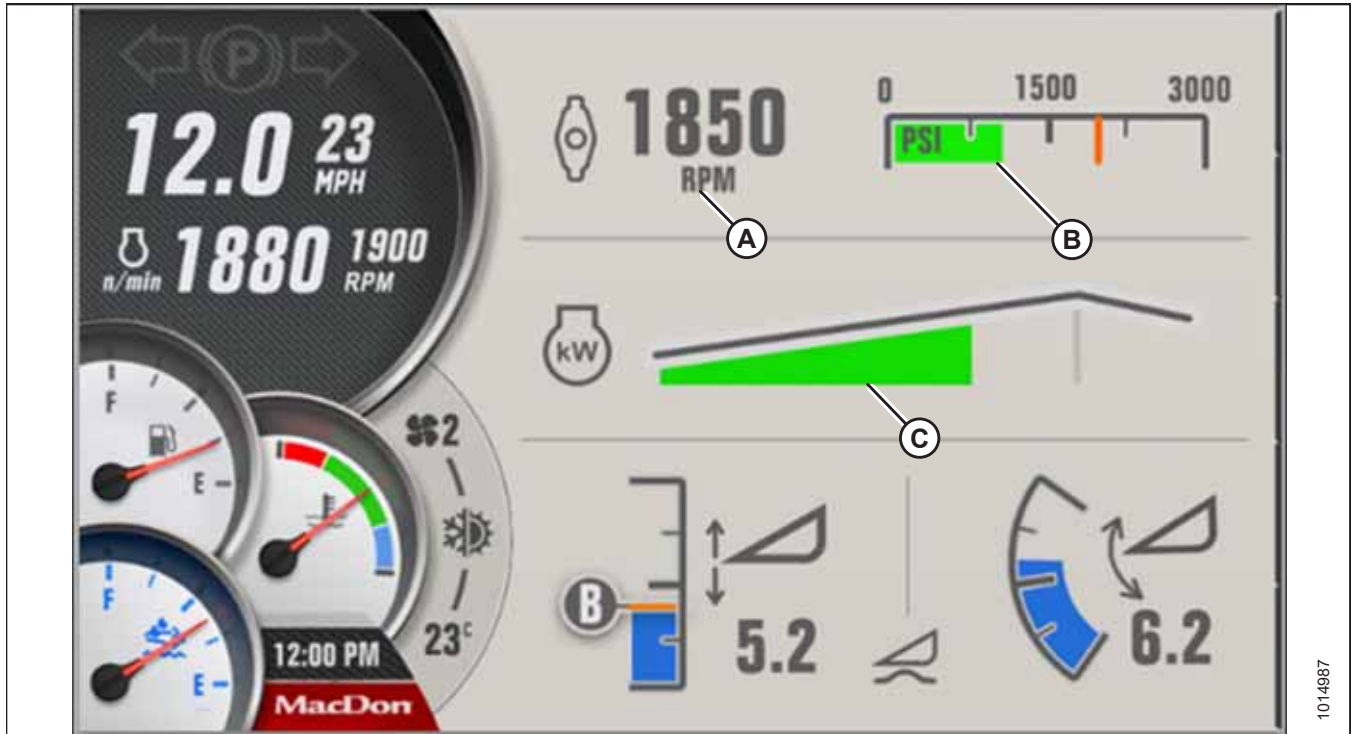

Figure 4.369: Run Screen 1 – Rotary Disc Header Display

A - Disc Speed

B - Disc Pressure

C - Engine Load Bar

OPERATION

Run Screen 2

This is what Run Screen 2 looks like when operating a rotary disc header.



Figure 4.370: Run Screen 2 – Rotary Disc Header Display

A - Disc rpm Digital

B - Disc Pressure Digital

C - Engine Load Bar

D - Hydraulic Oil Temperature

4.11 Operating with an R113 or R216 Rotary Disc Header

4.11.1 Disc Speed

The ideal disc speed should achieve a clean cut. Crop types and conditions affect disc and ground speeds.

Refer to the header operator's manual for the suggested disc speed for a variety of crops and conditions.

Setting Disc Speed

The default disc speed is 2000 rpm. The minimum disc speed is 1500 rpm. The maximum disc speed is 2700 rpm. Follow these steps to adjust the disc speed.

WARNING

Check to be sure all bystanders have cleared the area.

1. Engage the header. For instructions, refer to *Engaging and Disengaging the Header, page 225*.
2. Adjust the disc speed with DISC SPEED INCREASE (A) or DISC SPEED DECREASE (B) buttons on the ground speed lever (GSL).

NOTE:

Disc speed increases 50 rpm per momentary button push, or at a rate of 100 rpm/sec if the button is pushed and held.



Figure 4.371: GSL

OPERATION

Adjusting Disc Pressure Alarm

Adjusting the disc alarm allows the operator to set an alert to inform them that the disc is operating at a desired pressure. A lower setting will cause the alarm to be set off more often; a higher setting will allow the alarm to be set off less frequently. This adjustment requires the header to be in operation.

WARNING

Check to be sure all bystanders have cleared the area.

1. If RUN SCREEN 1 is not already displayed, press soft key 1 (A) on the Harvest Performance Tracker (HPT) to display draper RUN SCREEN 1.



Figure 4.372: Disc Header Run Screen 1

2. Press scroll knob (A) on the Harvest Performance Tracker (HPT) or SELECT button (B) on the ground speed lever (GSL) to display the QuickMenu system.

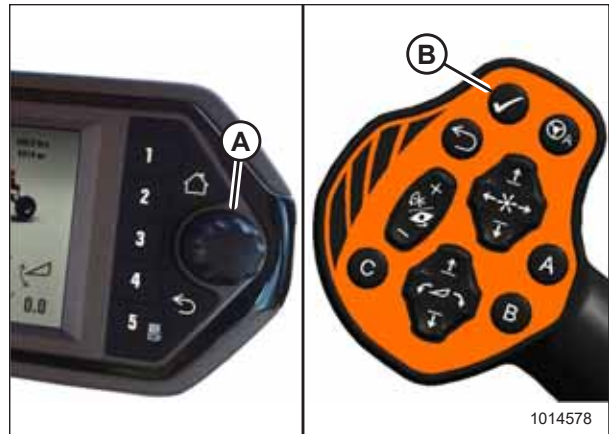

Figure 4.373: HPT Scroll Knob and GSL Select Button

OPERATION

3. Scroll to DISC SPEED setting (A) on the QuickMenu screen, and select it.

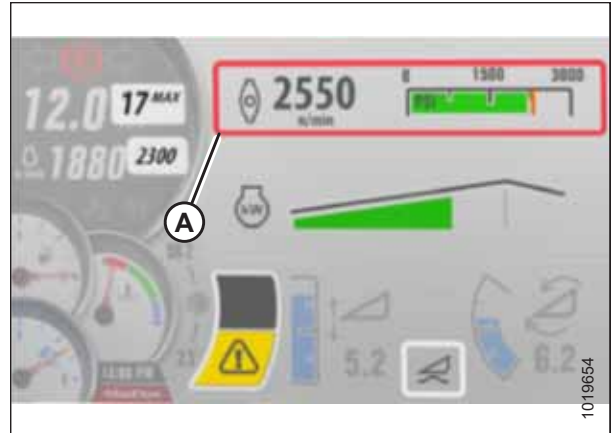

Figure 4.374: Disc Header QuickMenu Screen

4. Scroll to DISC PRESSURE ALARM setting (A), and select it.
5. Scroll to the desired alarm set-point or scroll past the highest setting to turn the alarm OFF. The digital value is replaced by three dashed lines, indicating that it is possible to adjust the alarm set-point value.
6. Adjust the disc alarm pressure set-point to desired value. Factory setting is 310 bar (4500 psi).



Figure 4.375: Disc Pressure Screen

4.11.2 Setting Float Options with Fixed Deck

When using an auger or rotary header, the DECK SHIFT buttons can be used to store three different float settings. This is useful when cutting in varying ground conditions, or when having one side lighter is desirable (such as cutting along wheel tracks or irrigation borders).

WARNING

Check to be sure all bystanders have cleared the area.

1. Start the engine and use HEADER TILT switches (A) and (B) on the ground speed lever (GSL) to set header tilt to the mid-range position.

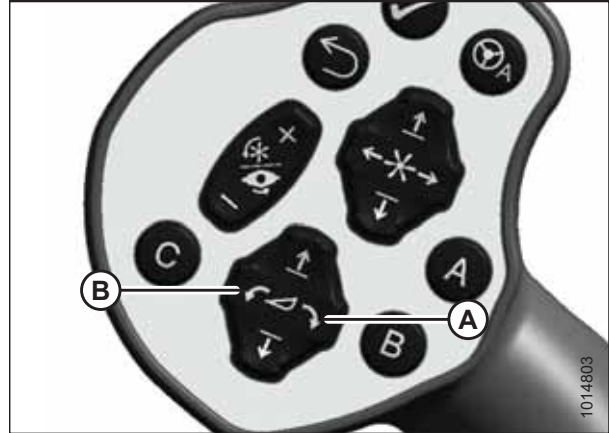

Figure 4.376: GSL

2. Engage the header by pushing and holding down HEADER ENGAGE switch (A), and pulling up on collar (B).

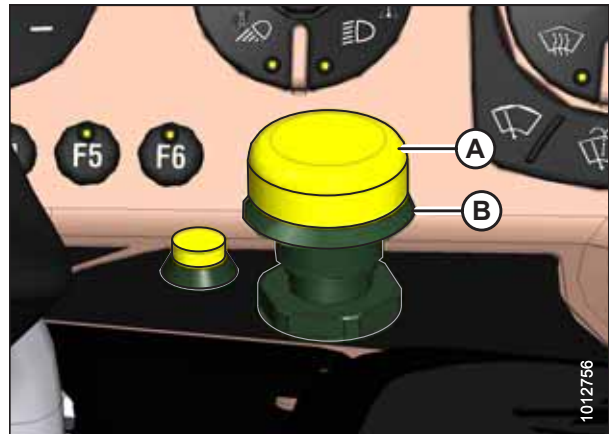

Figure 4.377: Header Engage Switch

OPERATION

3. Select one of the following deck positions using the DECK SHIFT switches on the operator's console:

- Right-side delivery (A)
- Center delivery (B)
- Left-side delivery (C)

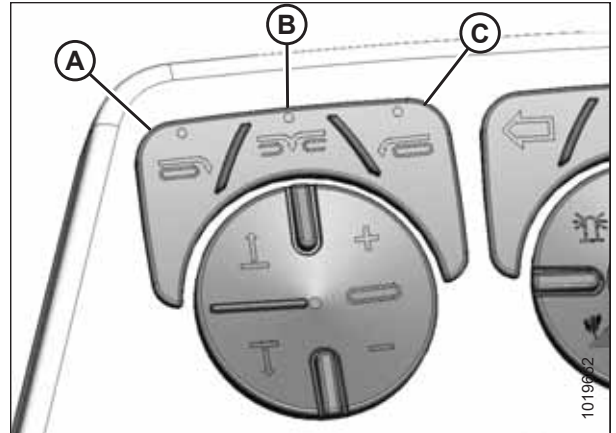

Figure 4.378: Header Deck Shift Switches

4. Disengage the header by pushing down on HEADER ENGAGE switch (A).
5. Adjust the float setting for the selected deck position. For instructions, refer to [Setting the Float, page 222](#).
6. Repeat steps for the other deck positions.



Figure 4.379: Header Engage Switch

4.11.3 Disc Header Run Screens

Two disc header specific run screens are viewable when operating windrower with an auger header attached. The screens are accessed by pressing the applicable soft keys on the Harvest Performance Tracker (HPT).

Run Screen 1

This is what Run Screen 1 looks like when operating a rotary disc header.



Figure 4.380: Run Screen 1 – Rotary Disc Header Display

A - Disc Speed

B - Disc Pressure

C - Engine Load Bar

OPERATION

Run Screen 2

This is what Run Screen 2 looks like when operating a rotary disc header.

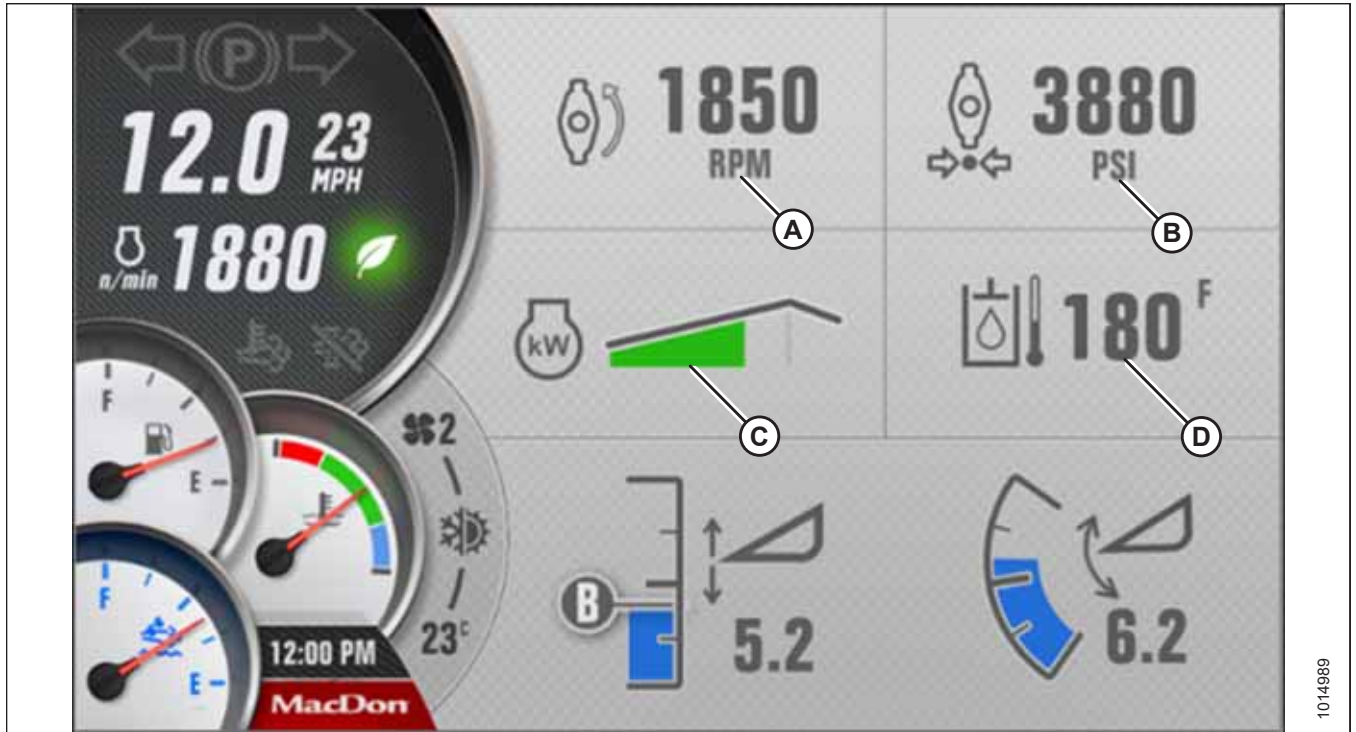

Figure 4.381: Run Screen 2 – Rotary Disc Header Display

A - Disc rpm Digital

B - Disc Pressure Digital

C - Engine Load Bar

D - Hydraulic Oil Temperature

Chapter 5: Maintenance and Servicing

The following section will guide you through the windrower's basic maintenance and service requirements.

5.1 Recommended Fuel, Fluids, and Lubricants

5.1.1 Storing Lubricants and Fluids

Your machine can only operate at top efficiency if clean fuel and lubricants are used.

- Buy good quality, clean fuel from a reputable Dealer.
- Use clean containers to handle fuel and lubricants.
- Store in an area protected from dust, moisture, and other contaminants.
- Avoid storing fuel over long periods of time. If you have a slow fuel turnover in the windrower or supply tank, add fuel conditioner and keep tank full to avoid condensation problems.
- Store fuel in a convenient place away from buildings.
- Diesel exhaust fluid (DEF) should be stored in a cool, dry, well ventilated area, out of direct sunlight, on lower shelf or on floor.
- DEF is corrosive to some metals and should only be stored in polyethylene, polypropylene, or stainless steel containers.
- DEF containers should be sealed to prevent contamination and the evaporation of water, which will affect the specified water to urea ratio.
- Diesel fuel should **NEVER** be mixed with DEF.

NOTE:

DEF will degrade over time depending on temperature and exposure to sunlight. Shelf life specifications, as defined by ISO Spec 22241-3, are the minimum expectations for shelf life when stored at constant temperatures. If stored between 12 to 32°C (10 to 90°F), shelf life will easily be one year. If the maximum temperature does not exceed approximately 24°C (75°F) for an extended period of time, the shelf life will be two years.

MAINTENANCE AND SERVICING

5.1.2 Fuel Specifications

Use only ultra low sulphur diesel (ULSD) from a reputable supplier. For most year-round service, No. 2 ULSD fuel meeting ASTM specification D975 Grade S15 will provide good performance.

If the vehicle is exposed to extreme cold (below -7°C [20°F]) or is required to operate at colder-than-normal conditions for prolonged periods, use climatized No. 2 diesel fuel, or dilute the No. 2 ULSD fuel with 50% No. 1 ULSD fuel. This will provide better protection from fuel gelling or wax-plugging of the fuel filters.

Table 5.1 Fuel Specifications

Fuel	Specification	Sulphur (by weight)	Water and Sediment (by volume)	Cetane No. °C (°F)	Lubricity
ULSD Grade No. 2	ASTM D975	0.5% maximum	0.05% maximum	40 (104) minimum	520 Microns
ULSD Grade No. 1 and 2 mix ¹³	n/a	1% maximum 0.5% maximum preferred	0.1% maximum	45–55 (113–130) cold weather / high altitude	460 Microns

In extreme situations, when available fuels are of poor quality or problems exist which are particular to certain operations, additives can be used; however, the engine manufacturer recommends consultation with the fuel supplier or engine manufacturer before using fuel additives. Situations where additives are useful include:

- A cetane improver additive can be used with low cetane fuels.
- A wax crystal modifier can help with fuels with high cold filter plugging points (CFPP).
- An anti-icer can help prevent ice formation in wet fuel during cold weather.
- An antioxidant or storage stability additive can help with fuel system deposits and poor storage stability.
- Diesel fuel conditioner can be used to increase the lubricity of fuels so that they meet the requirements given in Table 5.1, page 294. Diesel fuel conditioner is available from your Dealer.

13. Optional when operating temperature is below 0°C (32°F).

5.1.3 Lubricants, Fluids, and System Capacities



WARNING

To avoid injury or death, do NOT allow ANY machine fluids to enter the body.

Table 5.2 System Capacities

Lubricant/Fluid	Location	Description	Capacity
Diesel exhaust fluid (DEF)	Diesel exhaust fluid tank	Must meet ISO 22241 requirements.	28 liters (7.5 U.S. gallons)
Grease	As required unless otherwise specified	SAE multi-purpose high temperature extreme pressure (EP2) performance with 1% max molybdenum disulphide (NLGI Grade 2) lithium base	As required unless otherwise specified
Diesel fuel	Fuel tank	Ultra low sulphur diesel (ULSD) Grade No. 2, or ULSD Grade No. 1 and 2 mix ¹⁴ ; refer to 5.1.2 Fuel Specifications, page 294 for more information	518 liters (137 U.S. gallons)
Hydraulic oil	Hydraulic reservoir	Single grade transmission/hydraulic fluid (THF) Recommend Viscosity: <ul style="list-style-type: none"> • 60.1 cSt @ 40°C • 9.5 cSt @ 100°C Recommended brands: <ul style="list-style-type: none"> • AGCO Power Fluid 821XL • Case HY-TRAN ULTRACTION • John Deere Hy-Gard J20C • Petro-Canada DURATRAN 	60 liters (15.8 U.S. gallons) ¹⁵
Gear lubricant	Gearbox	SAE 75W-140 or 80W-140, API service class GL-5 fully synthetic gear lubricant (SAE J2360 preferred)	2.3 liters (2.4 U.S. quarts)
Gear lubricant	Standard Wheel drive	SAE 75W-140 or 80W-140, API service class GL-5 fully synthetic gear lubricant (SAE J2360 preferred)	1.4 liters (1.5 U.S. quarts)
Gear lubricant	High Torque Wheel drive	SAE 85W-140, API service class GL-5 fully synthetic gear lubricant	4.5 liters (4.8 U.S. quarts)
Antifreeze	Engine cooling system	ASTM D-6210 and Fleetguard ES Compleat®	33 liters (8.7 U.S. gallons) ¹⁶
Engine oil	Engine oil pan	SAE 15W-40 compliant with SAE specs for API Class SJ and CJ-4 engine oil	14 liters (14.8 U.S. quarts)
Air conditioning refrigerant	Air conditioning system	R134A	2.38 kg (5.25 lb.)

14. Optional when operating temperature is below 0°C (32°F).

15. Denotes capacity of a dry system. Refill capacity is 58 liters (15 U.S. gallons).

16. Equal parts with water; high quality, soft, deionized or distilled water as recommended by Supplier.

MAINTENANCE AND SERVICING

Table 5.2 System Capacities (continued)

Lubricant/Fluid	Location	Description	Capacity
Air conditioning refrigerant oil	Air conditioning system total capacity	PAG SP-15	240 cc (8.1 fl. oz.)
Windshield washer fluid	Windshield washer fluid tank	SAE J942 compliant	4 liters (1 U.S. gallon)

If Fleetguard ES Compleat® is unavailable, use a coolant concentrate or prediluted coolant intended for use with heavy duty diesel engines and with a minimum of the following chemical and physical properties:

- Provides cylinder cavitation protection according to fleet study run at or above 60% load capacity.
- Protects the cooling system metals (cast iron, aluminum alloys, and copper alloys such as brass) from corrosion.

The additive package must be part of one of the following coolant mixtures:

- Ethylene glycol or propylene glycol base prediluted (40–60%) heavy duty coolant.
- Ethylene glycol or propylene glycol base heavy duty coolant concentrate in a 40–60% mixture of concentrate with quality water.

Water quality is important to the performance of the cooling system. Distilled, deionized, or demineralized water is recommended for mixing with ethylene glycol and propylene glycol base engine coolant concentrate.

IMPORTANT:

Do **NOT** use cooling system sealing additives or antifreeze that contains sealing additives.

5.1.4 Filter Part Numbers

Table 5.3 M1240 Filter Part Numbers

Filter	Part Number
Engine oil filter	MD #111974
Hydraulic charge oil filter	MD #201713
Hydraulic return oil filter	MD #202986
Primary fuel filter element	MD #205028
Secondary fuel filter element	MD #205029
Fuel strainer (fuel tank vent line) filter	MD #111608
Primary element (cab)	MD #111060
Primary air filter element	MD #138685
Secondary air filter element	MD #139077
Return air filter	MD #109797
Diesel exhaust fluid (DEF) – suction filter	MD #207478
Diesel exhaust fluid (DEF) – vent hose filter	MD #111608
DEF supply module filter kit	MD #207510

5.2 Windrower Break-In Inspections and Maintenance Schedule

The maintenance schedule specifies the recommended periodic maintenance procedures and service intervals. Regular maintenance is the best insurance against early wear and untimely breakdowns. Follow this schedule to maximize machine life.

For detailed instructions, refer to the various procedures in this chapter. Use the fluids and lubricants specified in [5.1 Recommended Fuel, Fluids, and Lubricants, page 293](#).

Service Intervals: The recommended service intervals are in hours of operation. Where a service interval is given in more than one time frame, for example 100 hours or annually, service the machine at whichever interval is reached first.

IMPORTANT:

Recommended intervals are for average conditions. Service the machine more often if operated under adverse conditions (severe dust, extra heavy loads, etc.).

 **CAUTION**

Carefully follow safety messages given in [1 Safety, page 1](#).

5.2.1 Break-in Inspection Schedule

Break-in Inspections		
Hours	Item	Check
1	Drive wheel nuts	Torque: 510 Nm (375 lbf·ft) dry Repeat checks at one hour intervals until torque stabilizes at two consecutive checks
5	A/C compressor belt	Tension
5	Caster wheel nuts	Torque: 170 Nm (125 lbf·ft)
5	Caster wheel anti-shimmy dampener bolts	Inboard bolt torque: 136 Nm (100 lbf·ft) Outboard bolt torque: 244 Nm (182 lbf·ft) Outboard jam nut: 136 Nm (100 lbf·ft)
5	Walking beam width adjustment bolts	Torque: 759 Nm (560 lbf·ft)
10	Walking beam width adjustment bolts	Torque: 759 Nm (560 lbf·ft)
50	Drive wheel nuts	Torque: 510 Nm (375 lbf·ft) dry Repeat checks at one hour intervals until torque stabilizes at two consecutive checks
50	Hose clamps: air intake / radiator / heater / hydraulic	Hand-tighten unless otherwise noted
50	Walking beam width adjustment bolts	Torque: 759 Nm (560 lbf·ft)
50	Caster wheel nuts	Torque: 170 Nm (125 lbf·ft)
50	Caster wheel anti-shimmy dampener bolts	Inboard bolt torque: 136 Nm (100 lbf·ft) Outboard bolt torque: 244 Nm (182 lbf·ft) Outboard jam nut: 136 Nm (100 lbf·ft)
50	Engine gearbox oil	Change
50	Drive wheel lubricant	Change
50	Charge system oil filter	Change
50	Return oil filter	Change

5.2.2 Maintenance Schedule/Record

Windrower serial number: _____

Combine this record with the record in the header operator’s manual. Make copies of this page to continue the record.

Refer to *5 Maintenance and Servicing, page 293* for information about each maintenance procedure.

Maintenance Record	Action:	✓ - Check	☉ - Lubricate	▲ - Change	☼ - Clean	⊕ - Add
Hour meter reading						
Date						
Serviced by						
First use, refer to <i>5.2.1 Break-in Inspection Schedule, page 298</i>						
10 Hours or Daily¹⁷						
✓	Engine oil level ¹⁸					
✓	Engine gearbox oil level ¹⁸					
✓	Engine coolant level at reserve tank ¹⁸					
✓	Fuel tank ¹⁸					
✓	Drain fuel filter water trap ¹⁸					
✓	Hydraulic hoses and lines for leaks ¹⁸					
✓	Hydraulic oil level ¹⁸					
✓	Tire inflation ¹⁸					
✓	Diesel exhaust fluid (DEF) level ¹⁸					
Annually¹⁹						
✓	A/C blower					
✓	Antifreeze concentration					
✓	Battery charge					
✓	Battery fluid level					
✓	Steering linkages					
50 Hours						
☼	Cab fresh air intake filter					
☉	Caster pivots					
☉	Forked caster wheel bearings					
☉	Top lift link pivots on lift arms (2 places on both sides [x4])					

17. Whichever occurs first.

18. A record of daily maintenance is not normally required but is at the Owner/Operator’s discretion.

19. Perform annual maintenance prior to start of operating season.

MAINTENANCE AND SERVICING

100 Hours or Annually^{17, 19}												
✱	A/C condenser											
✱	Charge air cooler											
✱	Hydraulic oil cooler											
✱	Radiator											
✱	Cab air return filter											
250 Hours or Annually^{17, 19}												
▲	Engine oil and filter											
▲	Engine air cleaner primary filter element											
●	Single-sided caster wheel hub bearings											
✓	Drive wheel lubricant level											
●	Mud caster wheel hub bearings											
✓	Exhaust system (visually inspect for leakage point, loose clamps or loose hose)											
▲	Engine gearbox oil											
500 Hours or Annually^{17, 19}												
▲	Primary and secondary fuel filters											
▲	Hydraulic return filter and charge filter											
✓	Safety systems											
1000 Hours												
✱	DEF supply module filter											
1000 Hours or Annually¹⁷												
▲	Fuel tank vent line filter											
▲	Wheel drive lubricant											
2000 Hours												
▲	Crankcase breather filter and gasket											
▲	DEF tank vent hose filter											
2000 Hours or Every Two Years¹⁷												
▲	Engine coolant											
✓	General inspection											
2000 Hours or Every Three Years¹⁷												
▲	Hydraulic oil											
4500 Hours or Every Three Years¹⁷												
▲	DEF supply module filter											

5000 Hours or Every Two Years ¹⁷												
✓	Engine valve tappet clearance											

5.2.3 Using the Electronic Maintenance Tool

The Electronic Maintenance Tool contains a list of items requiring service after 250 hours or more of windrower operation.

1. Press soft key 5 (A) to display the main menu.
2. To select the MAINTENANCE icon (C), use the Harvest Performance Tracker (HPT) scroll knob (B) or the ground speed lever (GSL) scroll wheel (not shown).
3. Press the HPT scroll knob (B) or the GSL SELECT button (not shown) to select the icon.



Figure 5.1: Opening the Main Menu

4. Select the MAINTENANCE icon (A) to open the maintenance menu (B). The following information can be viewed:
 - Completed maintenance
 - Selected maintenance notifications
 - Maintenance log

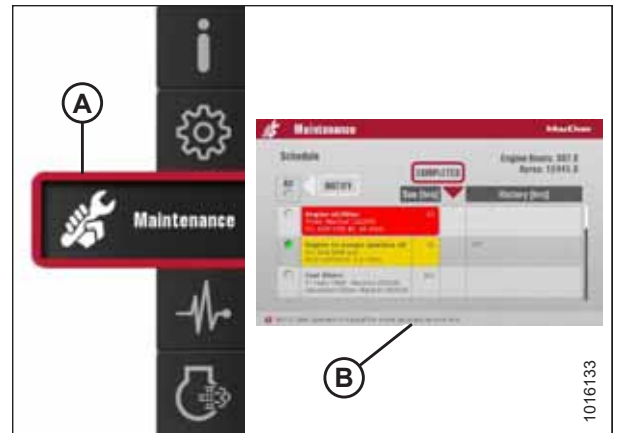

Figure 5.2: Maintenance Icon and Menu

5.3 Engine Compartment

CAUTION

- NEVER operate engine in a closed building. Proper ventilation is required to avoid exhaust gas hazards.
- Keep the engine clean. Straw and chaff on a hot engine are a fire hazard.
- NEVER use gasoline, naphtha, or any other volatile material for cleaning purposes. These materials are toxic and/or flammable.

5.3.1 Opening Hood

WARNING

To avoid bodily injury or death from unexpected startup of the machine, always stop the engine and remove the key from the ignition before leaving the operator's seat for any reason.

1. Shut down the engine, and remove the key from the ignition.
2. Move latch (A) towards right cab-forward side of the windrower.
3. Grasp louver (B), and lift hood to open.

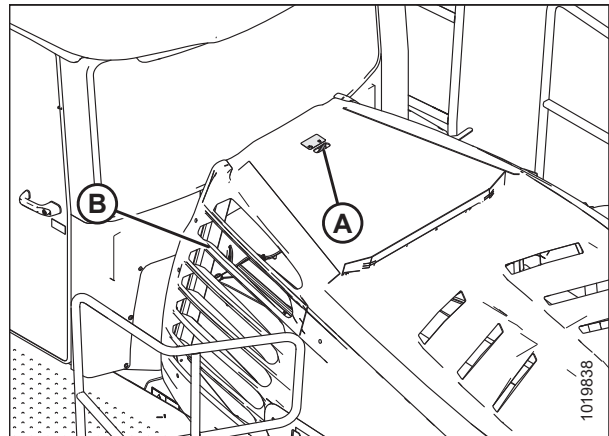

Figure 5.3: Hood

NOTE:

If the optional High Debris Cooler Intake kit (A) is installed, a louver can still be used to open the hood.

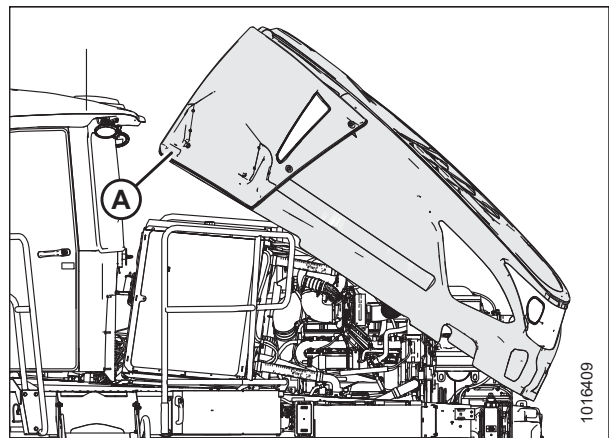

Figure 5.4: Hood with Optional High Debris Cooler Intake Kit

5.3.2 Closing Hood

1. Grasp hood by louver (A) and lower until hood engages latch.

NOTE:

Check that latch lever is not tilted to ensure hood is latched.

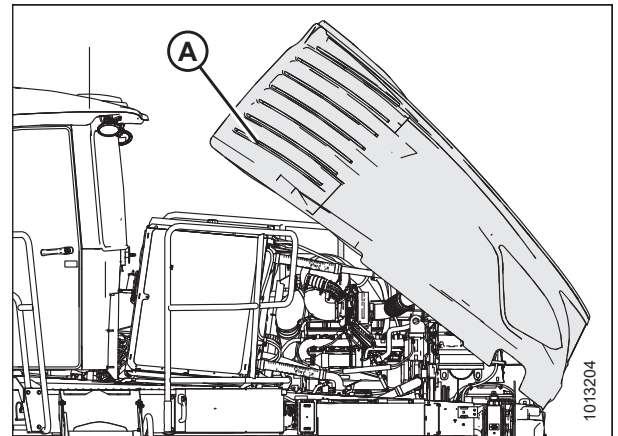

Figure 5.5: Engine Compartment

5.4 Platform

Swing-away platform and stair units are provided on the windrower for access to the operator's station and engine bay maintenance.

5.4.1 Opening Platform

Only the left cab-forward side platform can be opened.

CAUTION

Do NOT stand on an unlocked platform. It is unstable and may cause you to fall.

1. Approach platform (A) on the left cab-forward side of the windrower and ensure the cab door is closed.
2. Push latch (B), and pull platform (A) toward the walking beam until it stops and the latch engages.

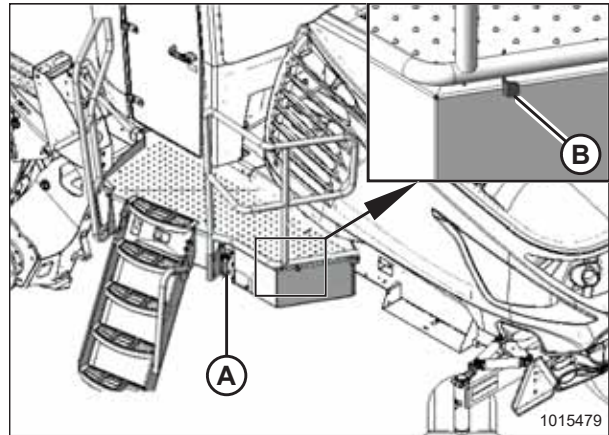

Figure 5.6: Left Cab-Forward Platform

5.4.2 Closing Platform

CAUTION

Do NOT stand on an unlocked platform. It is unstable and may cause you to fall.

1. Push latch (A) to unlock platform (B).

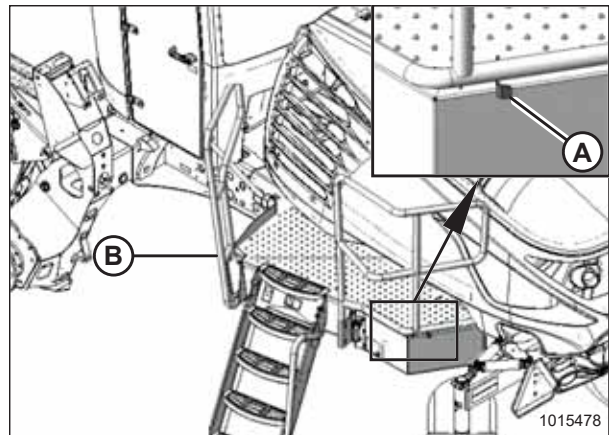

Figure 5.7: Left Cab-Forward Platform

MAINTENANCE AND SERVICING

2. Pull platform (A) towards the cab until it stops and latch engages.

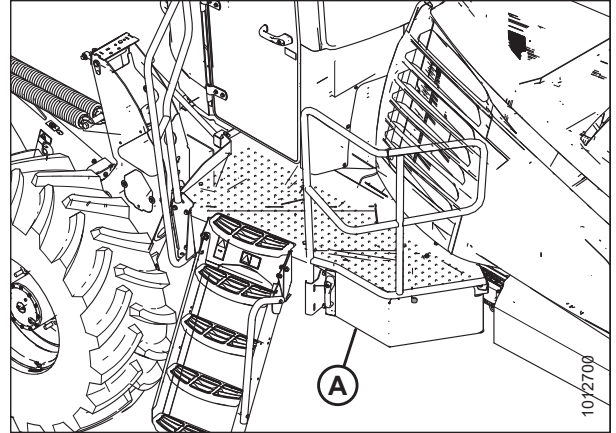

Figure 5.8: Left Cab-Forward Platform

5.4.3 Adjusting the Platform

To achieve proper gap between platform and frame, latch adjustment may be required.

1. Locate latch (B) beneath the platform.
2. Adjust the latch position by loosening bolts (A) and moving latch (B).
3. Retighten bolts (A) and close the platform.

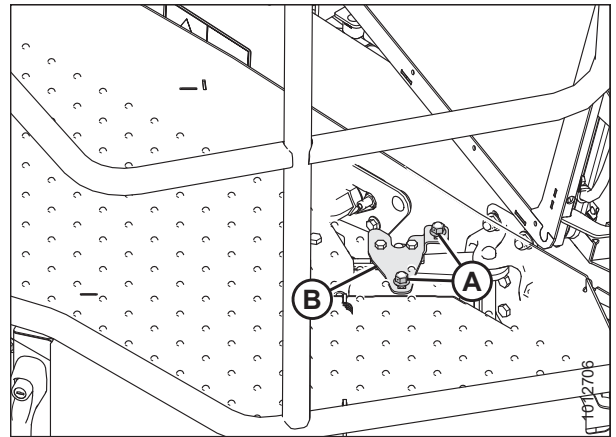

Figure 5.9: Left Platform

4. Rubber bumper (B) at the cab end of the platform should measure 52–60 mm (2–2 3/8 in.) when properly compressed against the frame. Platform should also sit firmly against front guide (A).

NOTE:

Top plate of platform removed for clarity.

5. If adjustment is required, loosen two bolts (C) and slide support as required.
6. Tighten bolts (C) to 39.5 Nm (29.1 lbf-ft).

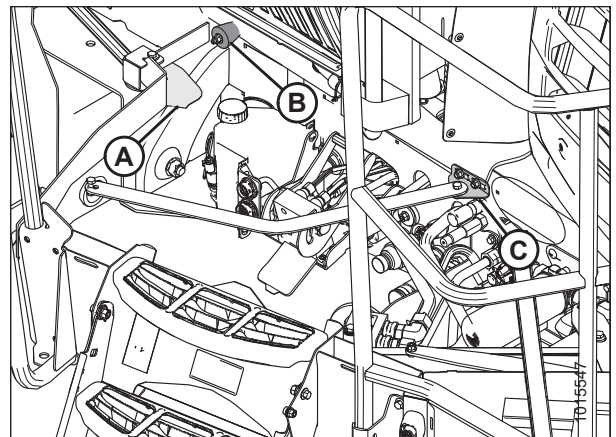

Figure 5.10: Left Platform

MAINTENANCE AND SERVICING

7. To adjust the horizontal position of the platform, loosen bolts (A) and adjust bolt (B).
8. Tighten bolts (A) to 68.5 Nm (50.5 lbf-ft).
9. Use bolts (C) to adjust the platform angle. Tighten bolts (C) to 68.5 Nm (50.5 lbf-ft) after adjustment is complete.

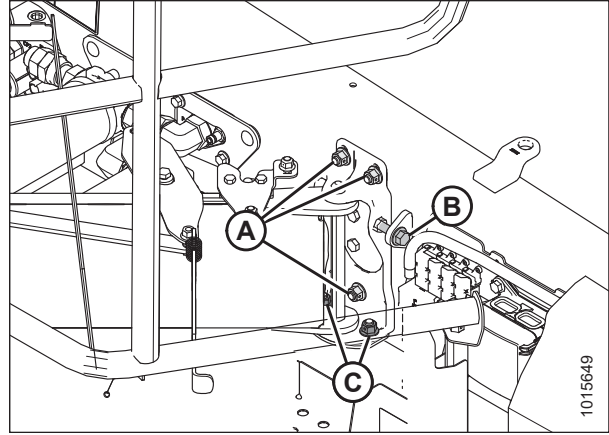

Figure 5.11: Left Platform

5.4.4 Accessing Tool Box

A tool box is located inside a storage compartment under the left cab-forward platform.

1. Grasp the handle on storage compartment (A) and press latch (B). Pull the unlatched handle to open the compartment.

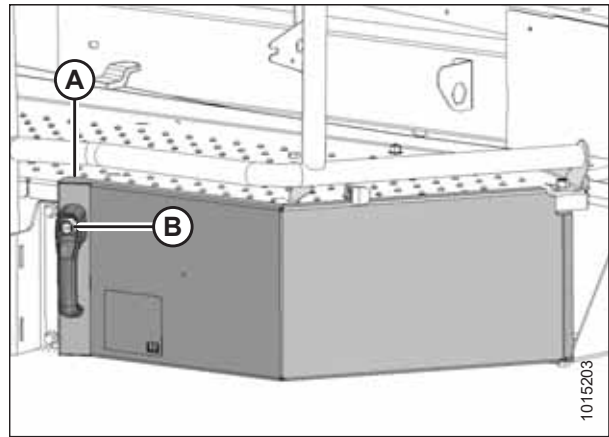

Figure 5.12: Tool Box

2. Tool box (A) is located inside storage compartment (B).
3. Swing compartment (B) under the platform to close it, and push on the handle to secure the latch.

NOTE:

The ignition key also locks the storage compartment.

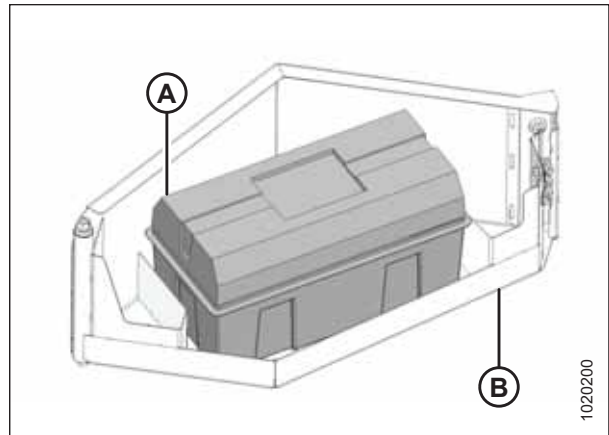

Figure 5.13: Tool Box

5.5 System Maintenance Overviews

5.5.1 Diesel Exhaust Fluid System

IMPORTANT:

If the windrower is going to be in storage for longer than 6 months, the diesel exhaust fluid (DEF) tank should be drained to avoid damaging the tank. For instructions, refer to *Draining the Diesel Exhaust Fluid Tank, page 307*.

IMPORTANT:

If the windrower temperature is going to be below 0°C (32°F), do **NOT** fill the DEF tank to a full level. It should be less than 75% full. When freezing, the DEF fluid will expand by approximately 7%.

NOTE:

For DEF fluid specifications, refer to this manual's inside back cover.

Draining the Diesel Exhaust Fluid Tank

It is necessary to drain the diesel exhaust fluid (DEF) tank when the DEF is contaminated or if storing the windrower for a period greater than 6 months.



WARNING

To avoid bodily injury or death from unexpected startup of the machine, always stop the engine and remove the key from the ignition before leaving the operator's seat for any reason.

1. Shut down the engine, and remove the key from the ignition.
2. Place a drain pan under DEF tank (B). The drain pan should be large enough to hold 28 liters (7.5 U.S. gallons).

IMPORTANT:

Spilled DEF must be contained and absorbed by non-combustible absorbent material like sand and then shovelled into a suitable container for disposal. If spilled on tank or any surface of the vehicle, rinse thoroughly with water as DEF is corrosive.



CAUTION

Avoid contact with eyes. In case of contact, rinse immediately with water for 15 minutes.

3. Remove drain plug (A) from under tank (B) and drain.
4. Add some distilled water to tank (B) to flush out remaining contaminants.
5. Drain the distilled water that was used to clean the tank.
6. Reinstall drain plug (A) into tank (B).
7. Refill DEF tank. For instructions, refer to *Filling the Diesel Exhaust Fluid Tank, page 308*.

NOTE:

Do **NOT** refill if storing for **6 months** or longer.

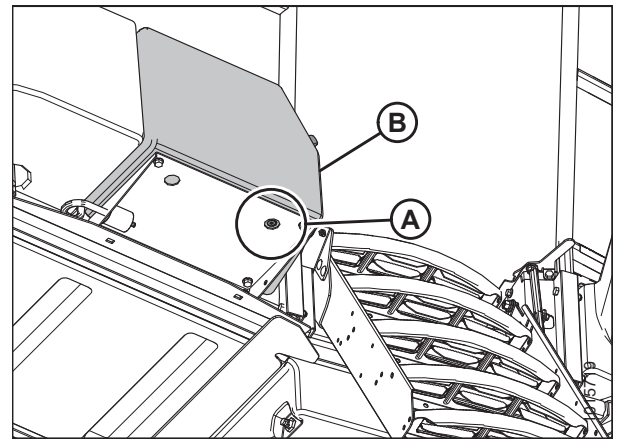

Figure 5.14: View from beneath Tank

Filling the Diesel Exhaust Fluid Tank

The symbol inside the diesel exhaust fluid (DEF) gauge on the Harvest Performance Tracker (HPT) display will signal when DEF level is low.

WARNING

To avoid bodily injury or death from unexpected startup of the machine, always stop the engine and remove the key from the ignition before leaving the operator's seat for any reason.

1. Shut down the engine, and remove the key from the ignition.
2. Clean around filler cap (A).
3. Turn cap (A) counterclockwise until loose and then remove the cap.

NOTE:

The filler cap for the DEF tank is blue and the nozzle dispenser is smaller than that of the fuel tank.

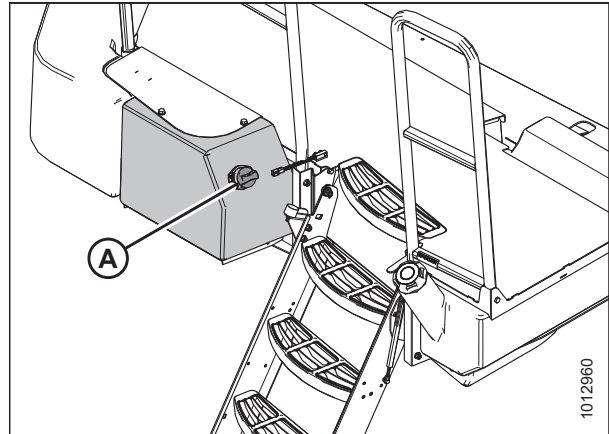

Figure 5.15: DEF Tank

CAUTION

Avoid contact with eyes. In case of contact, rinse immediately with water for 15 minutes.

4. Fill the tank with approved DEF. For specifications, refer to the inside back cover.

IMPORTANT:

DEF is corrosive. Spilled DEF must be contained and absorbed by non-combustible absorbent material like sand, and then shovelled into a suitable container for disposal. If spilled on the tank or any surface of the vehicle, rinse thoroughly with water.

IMPORTANT:

If the windrower temperature is going to be below 0°C (32°F), do **NOT** fill the DEF tank more than 75% full. When freezing, the DEF fluid will expand by approximately 7%. For storage information, refer to [5.1.1 Storing Lubricants and Fluids, page 293](#).

- Replace filler cap (A) and turn clockwise until tight.

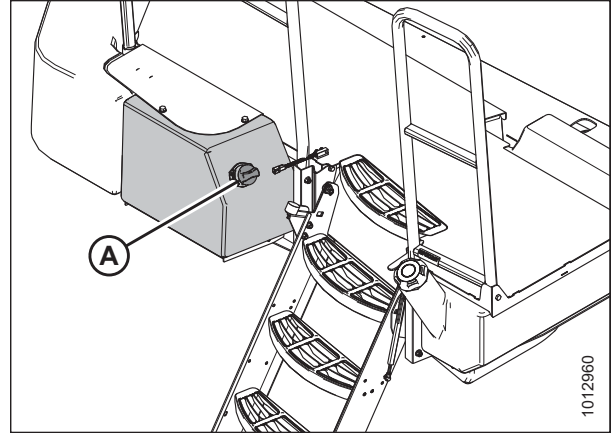

Figure 5.16: DEF Tank

5.5.2 Twin-Flow Cooling System

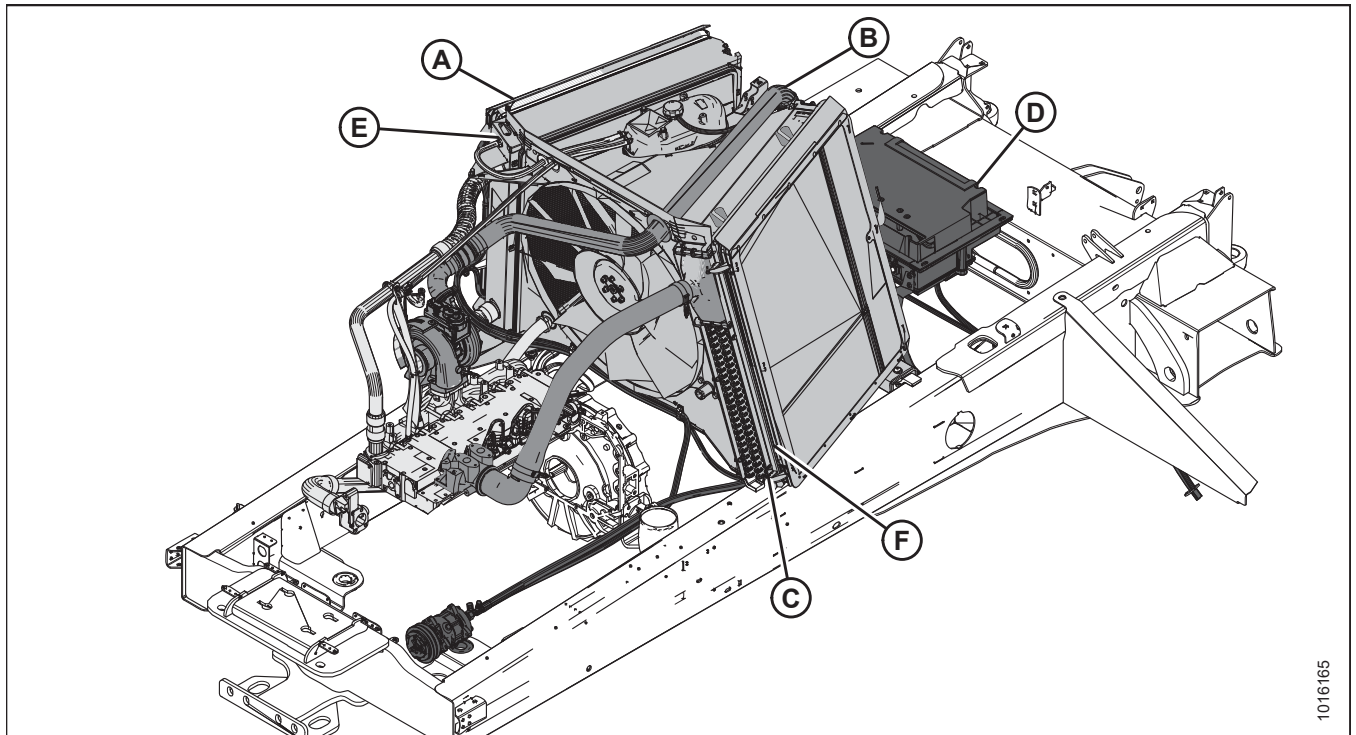

Figure 5.17: Cooling System

A - Air Conditioning Condenser
D - Air Conditioning Box

B - Charge Air Cooler
E - Engine Radiator

C - Hydraulic Oil Cooler
F - Case Drain Cooler

NOTE:

Antifreeze is essential in any climate. It broadens the operating temperature range by lowering the coolant freezing point and by raising its boiling point. Antifreeze also contains rust inhibitors and other additives to prolong engine life.

IMPORTANT:

If antifreeze strength is not adequate, do **NOT** drain the cooling system to protect against freezing. The system may not drain completely, and damage from freezing could still result.

Refer to [5.1.3 Lubricants, Fluids, and System Capacities, page 295](#) for detailed information.

Engine Cooling

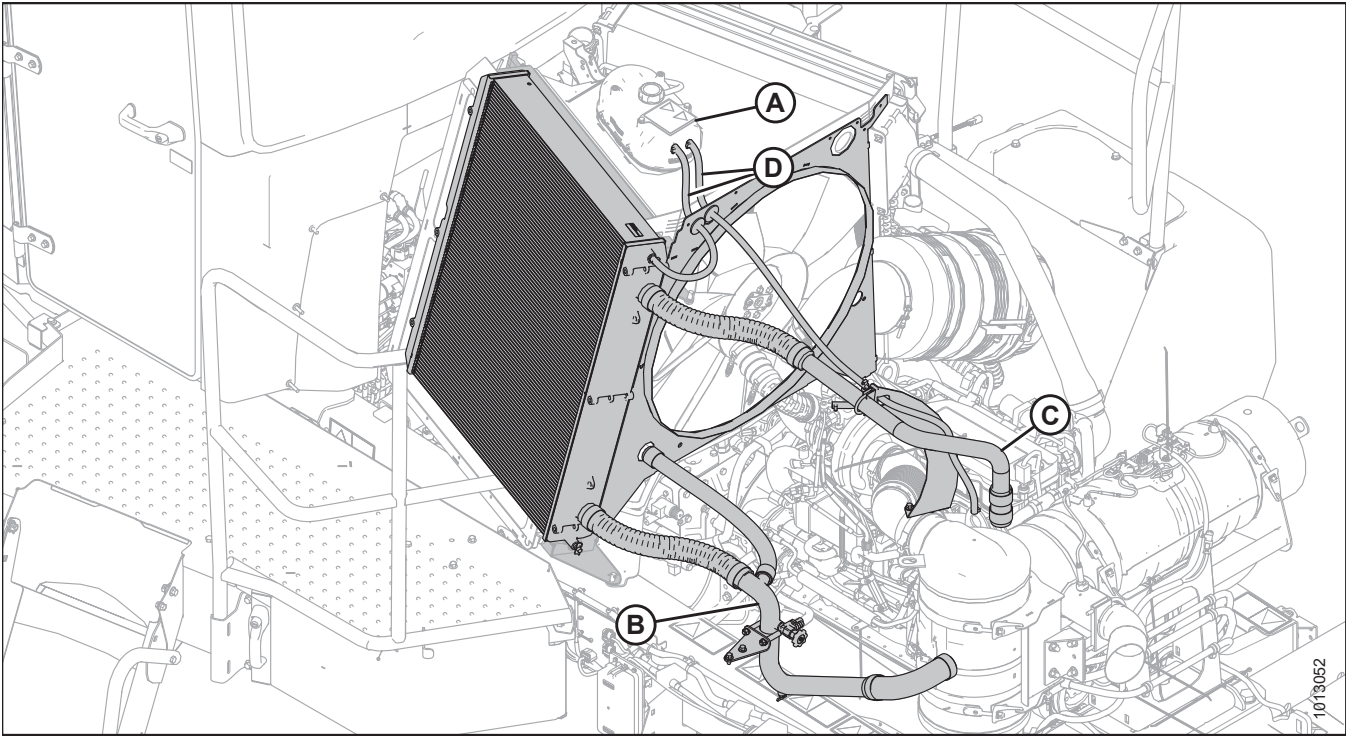

Figure 5.18: Engine Cooling

A - Pressurized Coolant Tank
C - Engine Outlet Hose

B - Engine Inlet Hose
D - Vent Hoses

Inspecting Pressurized Coolant Tank Cap

The pressurized coolant tank cap must fit tightly, and the cap gasket must be in good condition to maintain the 97–124 kPa (14–18 psi) pressure in the cooling system.

CAUTION

To avoid personal injury from hot coolant, do NOT turn pressurized coolant tank cap until engine cools.

WARNING

To avoid bodily injury or death from unexpected startup of the machine, always stop the engine and remove the key from the ignition before leaving the operator's seat for any reason.

1. Shut down the engine, and remove the key from the ignition.
2. Open the hood. For instructions, refer to [5.3.1 Opening Hood, page 302](#).

MAINTENANCE AND SERVICING

3. Turn cap (A) counterclockwise to the first notch to relieve pressure before removing the cap completely.
4. Turn cap (A) again and remove.
5. Check the gasket for cracks or deterioration, and replace the cap if necessary.
6. Check that the spring in the cap moves freely.
7. Replace the cap if spring is stuck.
8. Close the hood. For instructions, refer to [5.3.2 Closing Hood](#), page 303.

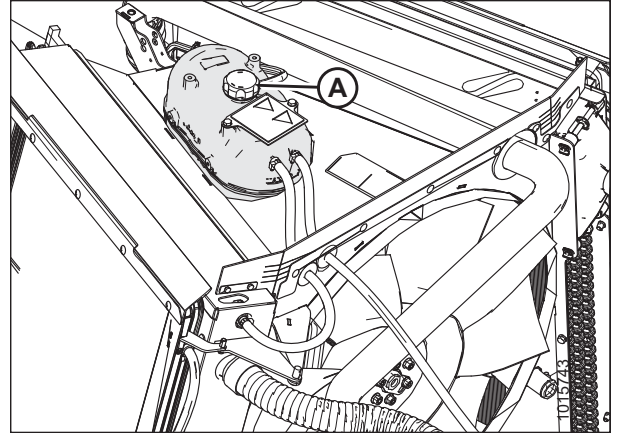

Figure 5.19: Coolant Tank

Charge Air Cooler

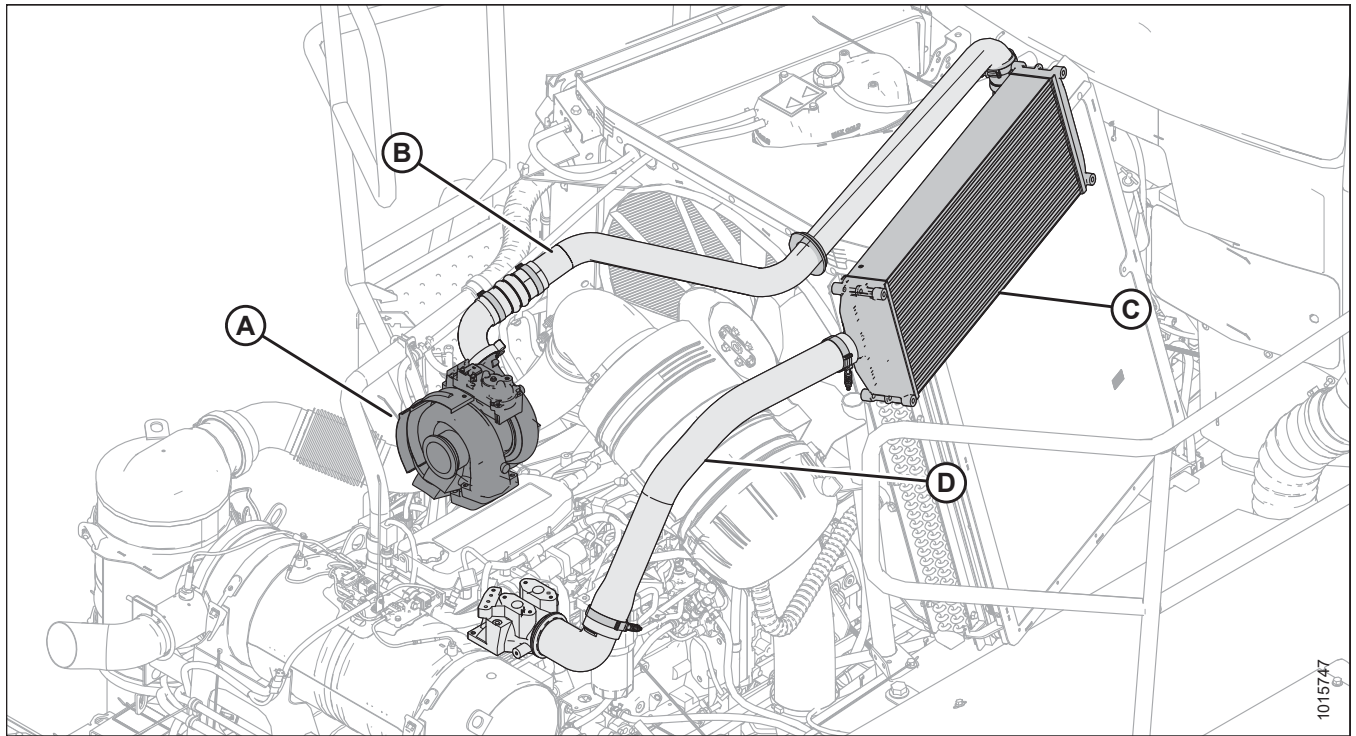

Figure 5.20: Charge Air Cooler (CAC)

A - Turbocharger
C - Charge Air Cooler

B - Charge Air Inlet Duct
D - Charge Air Outlet Duct

Charge Air Cooling

After the intake air passes through the air filter, it passes through turbocharger (A), which boosts the air pressure. This process heats the air so it is passed through pipe (B) to a cooler (C) before entering engine intake (D).

The cooler is located in the cooling box behind the cab. The cooler screens and components should be cleaned with compressed air every 100 hours of operation. Daily cleaning may be required if operating in heavy crop conditions. For instructions, refer to [5.9.2 Cleaning Cooler Module, page 350](#).

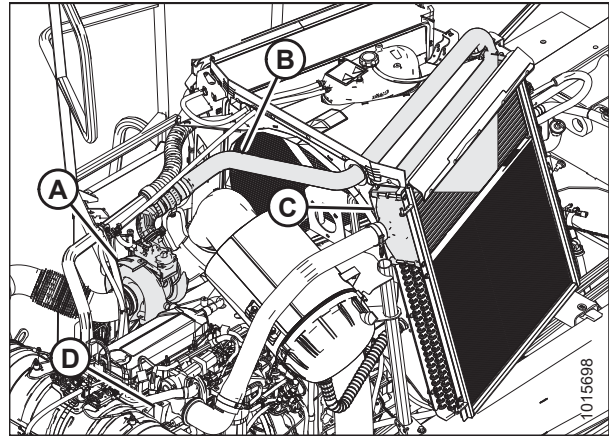

Figure 5.21: Engine Air Intake System

Hydraulic Oil Cooler

The hydraulic oil cooler is located inside the cooling box behind the radiator.

Clean cooler (A) with compressed air every 100 hours of operation. Daily cleaning may be required if operating in heavy debris conditions. For instructions, refer to [5.9.2 Cleaning Cooler Module, page 350](#).

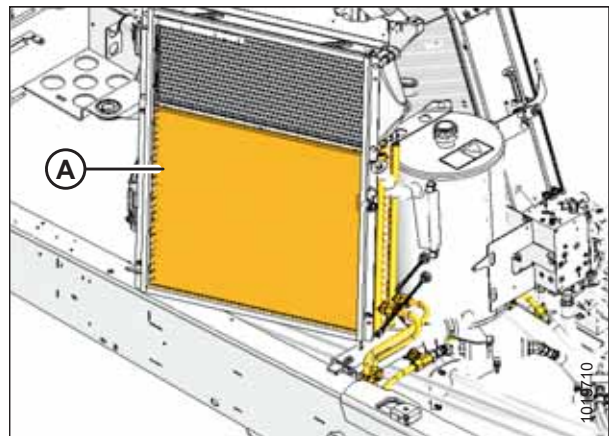

Figure 5.22: Hydraulic Oil Cooler

Air Conditioning (A/C)

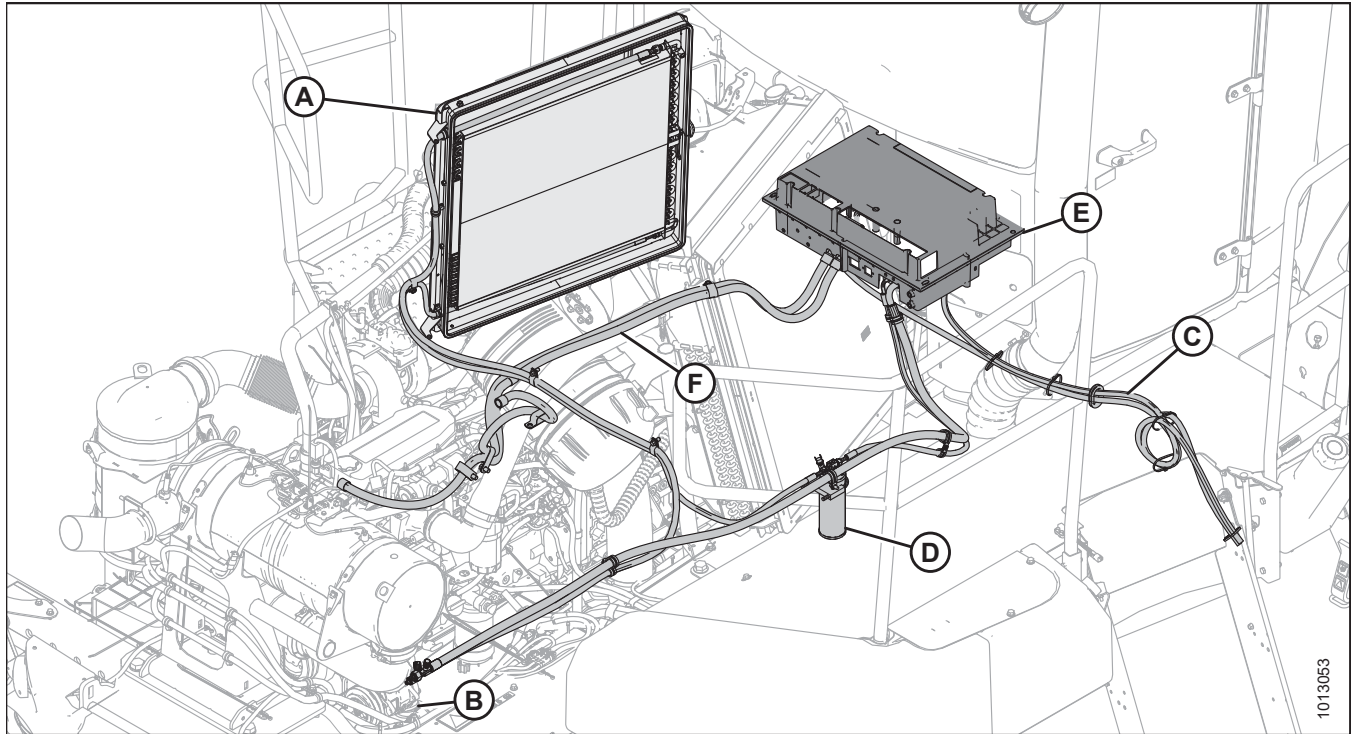

Figure 5.23: Air Conditioning

A - Condenser
D - Drier

B - Compressor
E - HVAC Unit

C - HVAC Drain Lines
F - Cab Heater Lines

Condenser

The air conditioning condenser should be cleaned with compressed air every 100 hours of operation. More frequent cleaning may be necessary in severe conditions.

Cleaning the condenser can be done at the same time as the radiator, oil cooler, and charge air cooler. For instructions, refer to [5.9.2 Cleaning Cooler Screens and Components, page 350](#).

5.5.3 Air Intake System

The air intake system filters air used by the engine.

IMPORTANT:

- Do **NOT** run engine with air cleaner disconnected or disassembled.
- Over-servicing the filter element increases the risk of dirt being ingested by the engine and severely damaging the engine.
- Filter servicing should only be performed when the Harvest Performance Tracker (HPT) indicates ENGINE AIR FILTER or at the specified interval. Refer to [5.2.2 Maintenance Schedule/Record, page 299](#).

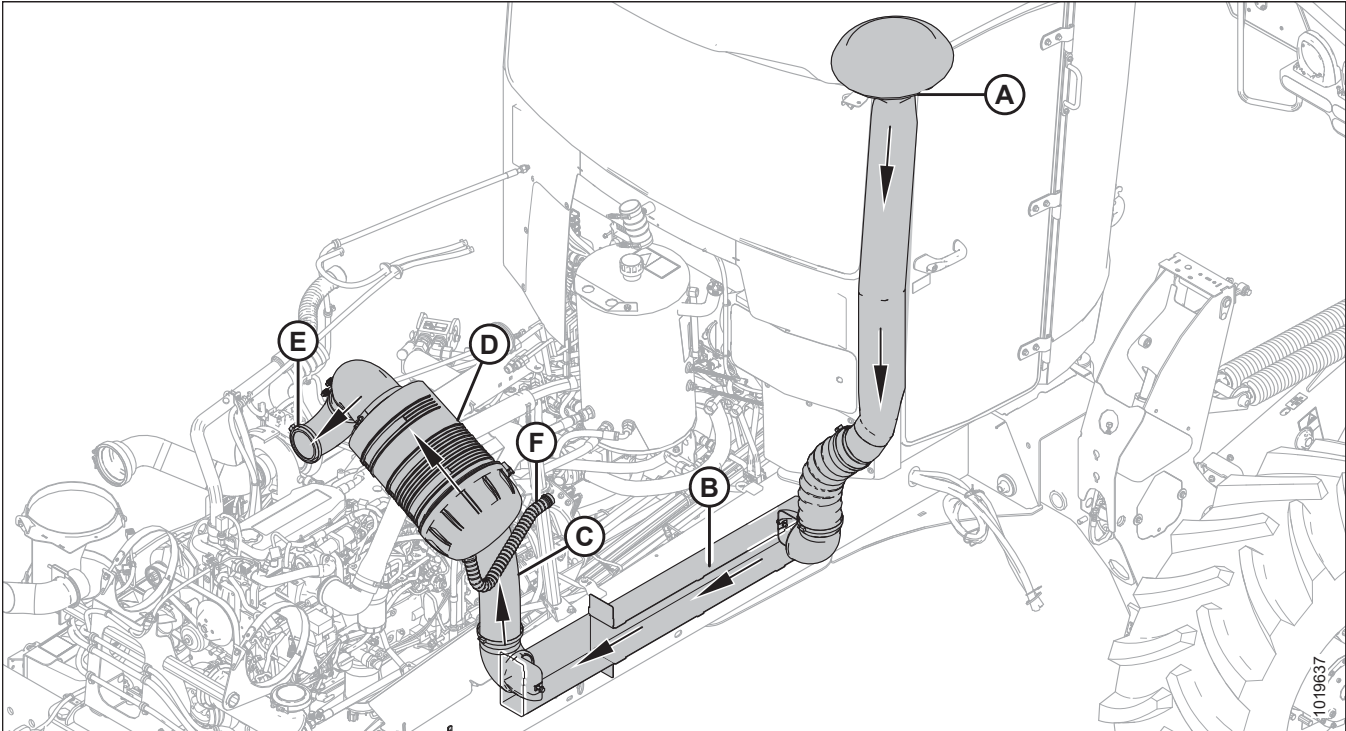

Figure 5.24: Air Intake System

A - Air Intake
D - Air Cleaner

B - Air Duct to Air Cleaner
E - Turbocharger Intake

C - Air Cleaner Intake
F - Aspirator Duct

Message (A) appears on the HPT when the engine air filter requires servicing.



Figure 5.25: Filter Service Required Message

5.5.4 Hydraulic System

The M1240 Windrower hydraulic system operates the windrower drive system, header lift, header drive systems, cooling systems fan, and other lift systems.

WARNING

- Avoid high-pressure fluids. Escaping fluid can penetrate the skin causing serious injury. Relieve pressure before disconnecting hydraulic lines.
- Tighten all connections before applying pressure. Keep hands and body away from pin-holes and nozzles which eject fluids under high pressure.



Figure 5.26: Hydraulic Pressure Hazard

WARNING

- Use a piece of cardboard or paper to search for leaks.
- If ANY fluid is injected into the skin, it must be surgically removed within a few hours by a Doctor familiar with this type of injury or gangrene may result.

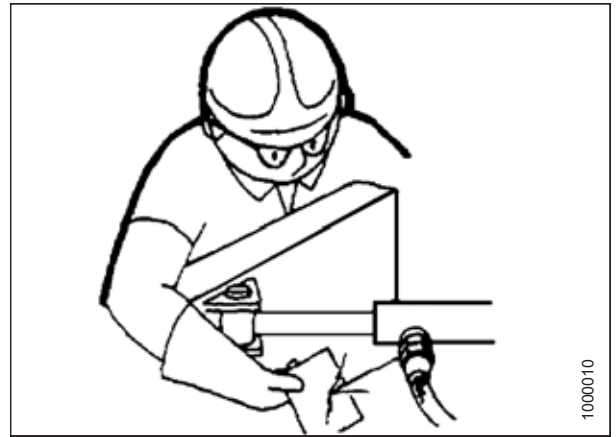

Figure 5.27: Checking Hydraulic Leaks

IMPORTANT:

Foreign material such as dirt, dust, and water is the major cause of damage in the hydraulic system.

If hydraulic system components must be disconnected for service, protect the ends of hoses, tubing, and ports of components from contamination with clean, lint-free towels, or clean plastic bags.

Before installing any replacement hose, flush the inside with unused diesel fuel or unused commercial petroleum cleaning solvent for ten seconds minimum. Do **NOT** use water, water soluble cleaners, or compressed air.

The hydraulic system components are built to very close tolerances and have been adjusted at the factory. Do **NOT** attempt to service these components except to maintain proper oil level, to change oil, and to change oil filters as described in this manual.

Contact your MacDon Dealer for all other service.

MAINTENANCE AND SERVICING

Hydraulic Oil Cooler

The hydraulic oil cooler is located inside the cooling box behind the radiator.

It should be cleaned with compressed air every 100 hours of operation. Daily cleaning may be required if operating in heavy debris conditions. For instructions, refer to [5.9.2 Cleaning Cooler Module, page 350](#).

Knife/Disc Drive Hydraulics

A single large piston hydraulic pump works in a closed-loop circuit providing oil to the knife/disc circuit.

The pump will maintain knife/disc speed at all normal operating engine speeds (>1500 rpm), regardless of varying loads on the header.

The pump requires charge flow in order to:

- Replace oil from internal leakages
- Fill and maintain positive pressure in the work circuit
- Provide flushing flow for cooling, and introduce clean oil into the circuit

Reel and Draper Hydraulics

The reel and draper circuits are powered by a gear pump. This allows independent oil flow to the reel and draper circuit and separates oil flow from the knife pump.

The header drive manifold manages flow control and relief for these circuits.

Traction Drive Hydraulics

The windrower traction drive consists of two variable displacement axial piston hydraulic pumps, one for each drive wheel.

The pump's speeds are increased through a gearbox from the engine. Each pump requires charge flow in order to:

- Replace oil from internal leakages
- Fill and maintain positive pressure in the work circuit
- Provide flushing flow for cooling (occurs at the motors), and introduce clean oil into the circuit

5.5.5 Electrical System

Module Layout

Module Locations

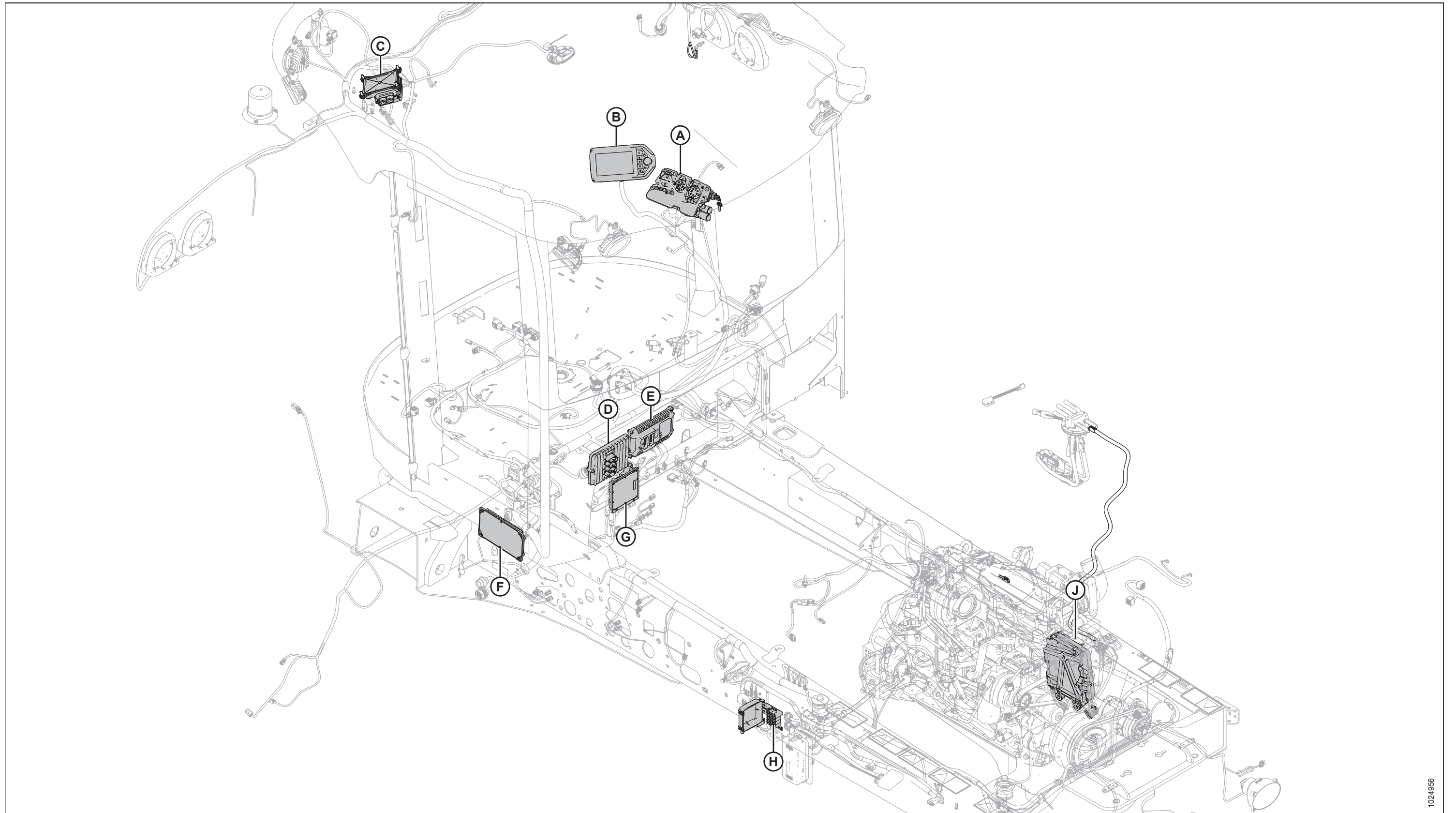

1024956

MAINTENANCE AND SERVICING

Module Locations Legend

A - Console Module (MD #208808)

D - Master Control Module (MD #205941)

G - HVAC Controller Module (MD 208110)²⁰

B - Harvest Performance Tracker Display (MD #306360)

E - Firewall Extension Module (MD #201396)

H - Chassis Relay Module (MD #208160)²⁰

C - Roof Relay Module (MD #208160)²⁰

F - Chassis Extension Module (MD #201396)

J - Engine ECM

²⁰. *Fuse Panel and Relay Module Decals, page 423*

Master Controller

The master controller houses the windrower software and communicates with all other electrical modules on the windrower.

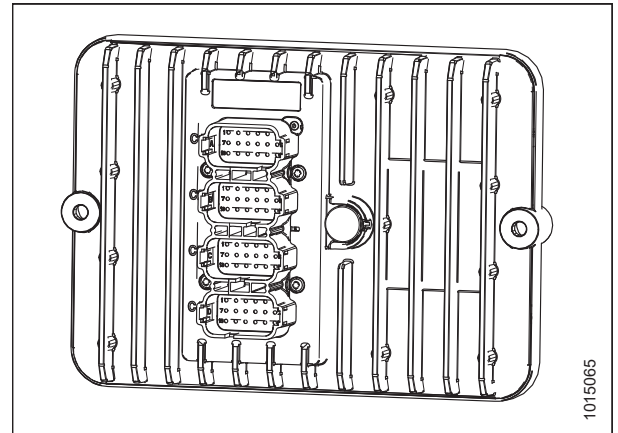

Figure 5.28: Master Controller

Extension Modules

The M1240 Windrower's has two extension modules. One is behind the cab, next to the master controller, and the other is located inside the left frame rail. They are used to provide inputs and outputs to various sensors and valve solenoids throughout the windrower.

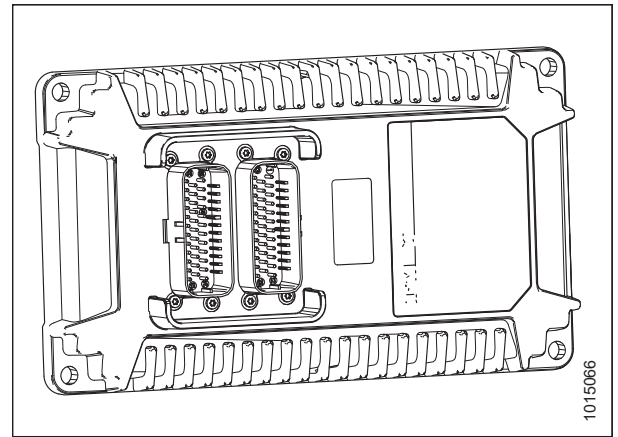

Figure 5.29: Extension Modules

Relay Modules

The M1240 Windrower has two relay modules. One is located on the chassis and the other inside the cab headliner. There are fuses and relays located in both relay modules.

The chassis relay module is located on the left (cab-forward) frame rail.

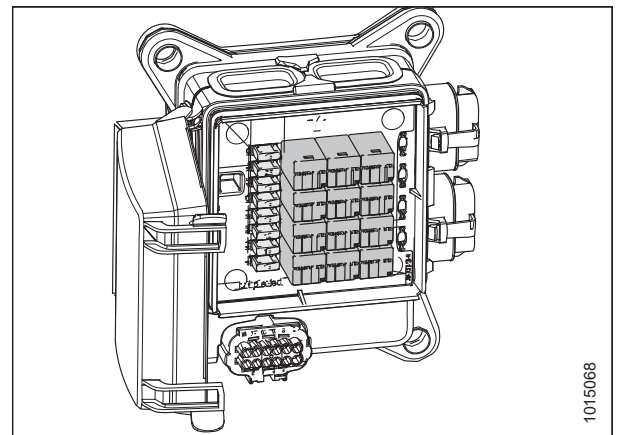

Figure 5.30: Chassis Relay Module

MAINTENANCE AND SERVICING

The roof relay module is located inside the cab's headliner.

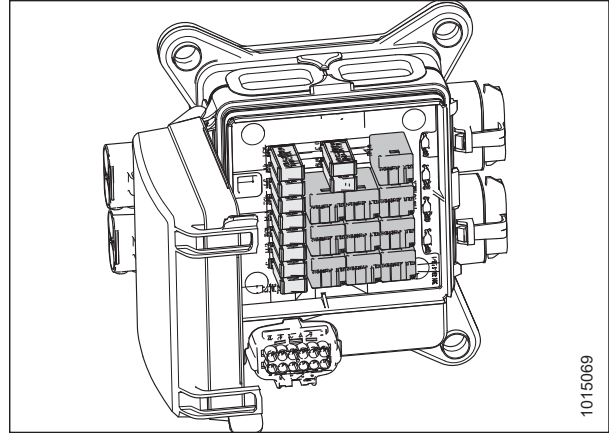

Figure 5.31: Roof Relay Module

Preventing Electrical System Damage

To prevent electrical system damage, take the following precautions:

- Carefully observe polarity when attaching booster battery.
- Do **NOT** short across battery or alternator terminals or allow battery positive (+) cable (B) or alternator wire to become grounded.
- Be sure alternator connections are correct before connecting the cables to the battery.
- When welding on any part of the machine, disconnect battery cables. For instructions, refer to [1.8 Welding Precaution, page 9](#).
- Always disconnect battery ground cables when working with the alternator or regulator.
- Never attempt to polarize alternator or regulator.
- If wires are disconnected from the alternator, refer to [Figure 5.32, page 322](#) to ensure proper connection.
- Never ground the alternator field terminal or field.
- Never connect or disconnect alternator or regulator wires with battery connected or alternator operating.
- Always disconnect cables from the battery when using a charger to charge battery in windrower.
- Ensure all cables are securely connected before operating engine.
- To avoid damage to circuit boards by static electricity, disconnect negative battery terminals when replacing electronic control modules. Furthermore, when handling electronic control modules, avoid touching the connector pins directly.

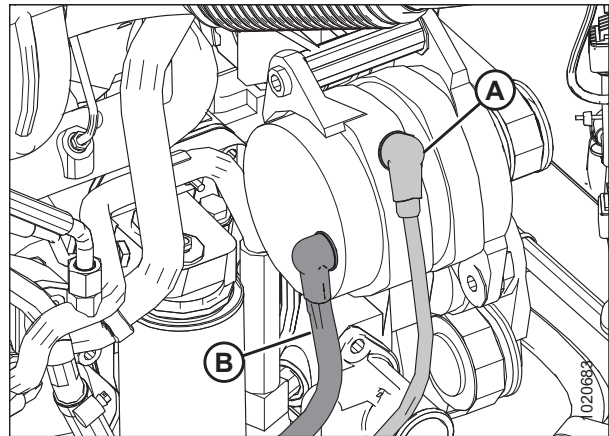

Figure 5.32: Alternator

A - Negative Terminal

B - Positive Terminal

5.6 Break-In Inspection Procedures

For the break-in schedule, refer to *5.2.1 Break-in Inspection Schedule, page 298*.

5.6.1 Tightening Drive Wheel Nuts

At first use or when a wheel is removed, check wheel nut/bolt torque every 15 minutes on the road or 1 hour in the field until the specified torque is maintained. Once specified torque is maintained, check wheel nut/bolt torque after 10 and 50 hours (field or road operation), and then every 200 hour intervals thereafter.

To tighten the drive wheel nuts, follow these steps:

IMPORTANT:

- To avoid damage to wheel rims and studs, tighten nuts by hand. Threads must be clean and dry, do **NOT** apply any lubricant or anti-seize compound. Do **NOT** use an impact gun, and do **NOT** overtighten wheel nuts.
- Use only genuine, manufacturer specified nuts.

1. Locate drive wheels (A).

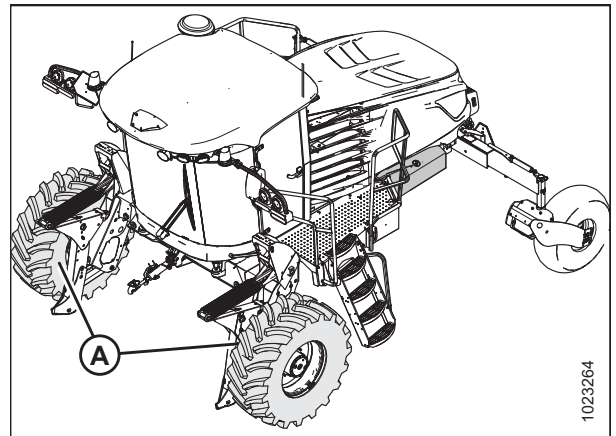

Figure 5.33: Drive Wheel Location

2. Torque each nut (A) to 510 Nm (375 lbf-ft) using the tightening sequence shown at right.
3. Repeat tightening sequence two additional times, ensuring the specified torque is achieved each time.
4. Repeat torque procedure every hour until two consecutive checks confirm that there is no movement of nuts (A).

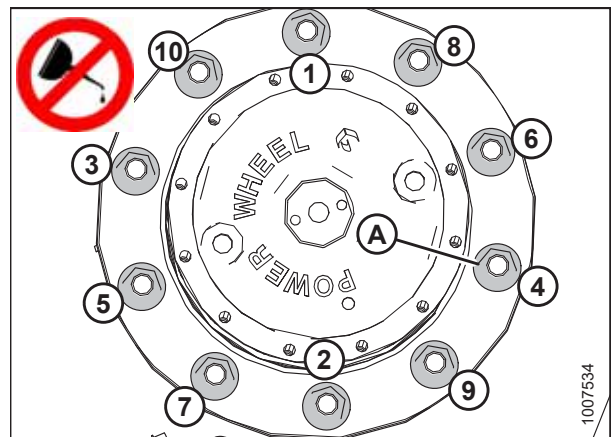

Figure 5.34: Drive Wheel — 10 Bolt

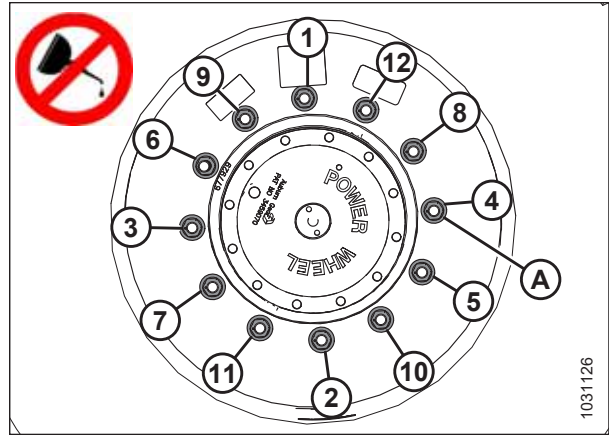

Figure 5.35: Drive Wheel – 12 Bolt (Optional)

5.6.2 Tightening Caster Wheel Nuts

At first use or when a wheel is removed, check wheel nut/bolt torque every 15 minutes on the road or 1 hour in the field until the specified torque is maintained. Once specified torque is maintained, check wheel nut/bolt torque after 10 and 50 hours (field or road operation), and then every 200 hour intervals thereafter.

1. Locate caster wheel assemblies (A).

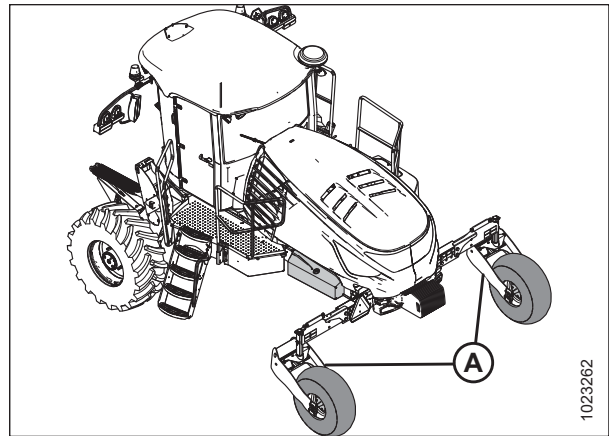

Figure 5.36: Caster Wheel Location

2. Tighten wheel nuts (A) to 163 Nm (120 lbf-ft) using the tightening sequence shown at right. Repeat the tightening sequence three times.

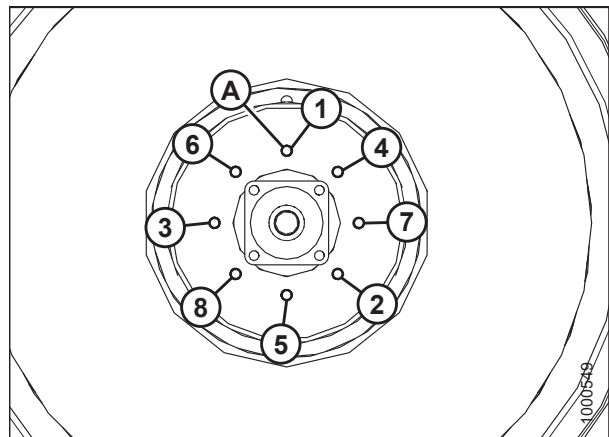

Figure 5.37: Forked Casters With Suspension

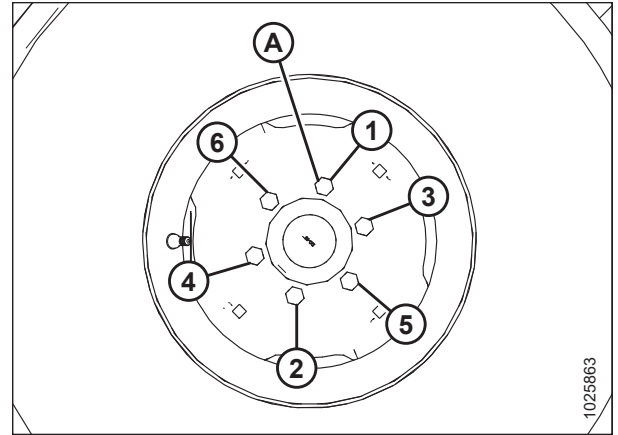

Figure 5.38: Single-Sided Caster

5.6.3 Tightening Caster Wheel Anti-Shimmy Dampeners

Each caster is equipped with two fluid-filled anti-shimmy dampeners (A).

Mounting bolts (B) and (C) need to be checked periodically for security. Refer to [5.2.2 Maintenance Schedule/Record, page 299](#).

- Two inboard bolts (B) should be tightened to 136 Nm (100 lbf-ft)
- Outboard bolt (C) should be tightened to 244 Nm (182 lbf-ft)
- Outboard jam nut (D) should be tightened to 136 Nm (100 lbf-ft)

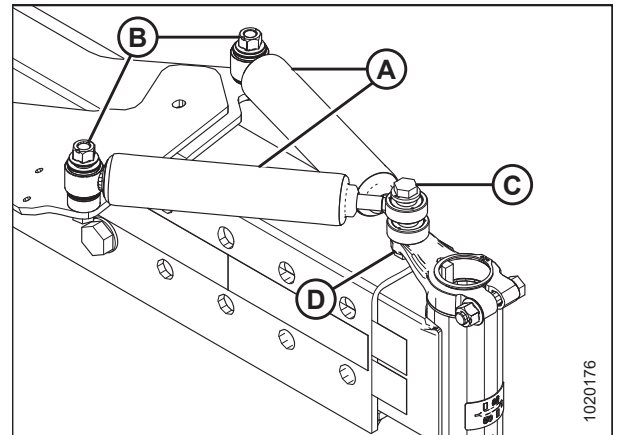

Figure 5.39: Anti-Shimmy Dampener

5.6.4 Tightening Walking Beam Adjustment Bolts

Check walking beam adjustment bolt torque after 5, 10, and 50 hours of field or road operation.

1. Tighten and torque back bolts (A) to 759 Nm (560 lbf-ft).
2. Tighten and torque bottom bolts (B) to 759 Nm (560 lbf-ft).
3. Repeat on opposite side.

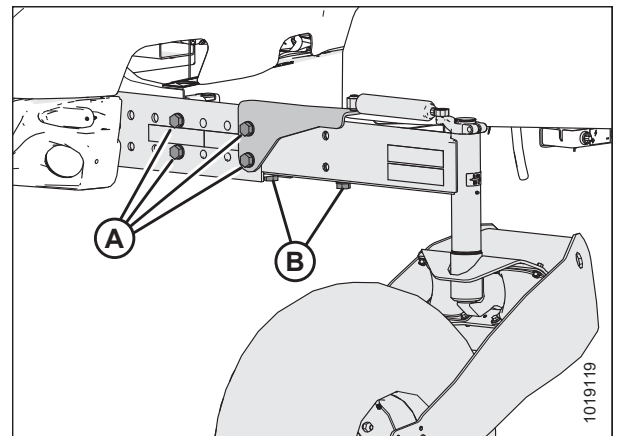

Figure 5.40: Walking Beam Adjustment Bolts

5.6.5 Tensioning Air Conditioner Compressor Belts

WARNING

To avoid bodily injury or death from unexpected startup of the machine, always stop the engine and remove the key from the ignition before leaving the operator's seat for any reason.

1. Shut down the engine, and remove the key from the ignition.
2. Open the hood. For instructions, refer to [5.3.1 Opening Hood, page 302](#).
3. Loosen compressor mounting hardware (A).
4. Pry compressor (B) away from engine so that a force of 45 N (10 lbf) deflects belts (C) 5 mm (3/16 in.) at mid-span.

NOTE:

Tab (D) on bracket can be used as support for prying.

5. Tighten compressor mounting hardware (A).
6. Recheck tension and readjust as required.
7. Close the hood. For instructions, refer to [5.3.2 Closing Hood, page 303](#).

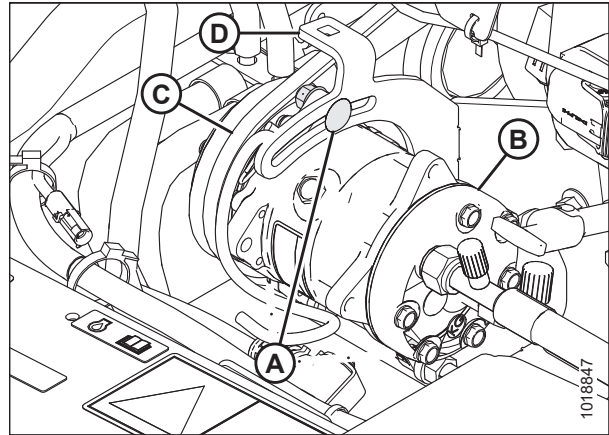

Figure 5.41: Air Conditioning (A/C) Compressor

5.6.6 Changing Engine Gearbox Lubricant

Change engine gearbox lubricant after the first 50 hours, and then at every 250 hours or annually.

WARNING

To avoid bodily injury or death from unexpected startup of the machine, always stop the engine and remove the key from the ignition before leaving the operator's seat for any reason.

CAUTION

Park on a flat, level surface with the header on the ground, the ground speed lever (GSL) in PARK position, and the steering wheel in locked position (centered). Wait for the HPT to beep and display a red P symbol to confirm the park brakes have engaged.

NOTE:

It is best to change lubricant in the morning before it warms up. If the engine is hot, wait 10 minutes before checking the lubricant level to allow the lubricant to cool and settle in the sump.

1. Park the windrower on a level surface.
2. Shut down the engine, and remove the key from the ignition.
3. Place a 4 liter (1 U.S. gallon) drain pan under the gearbox.
4. Remove drain plug (A) and allow lubricant to completely finish draining.
5. Inspect the drain plug. Small metal shavings are normal. If there are any larger metal pieces, an inspection of the gearbox will be required.
6. Install drain plug (A).

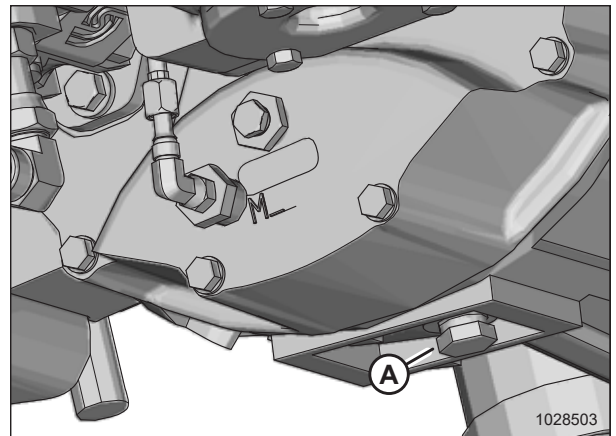

Figure 5.42: Engine Gearbox

7. Remove dipstick (A) and breather (B).

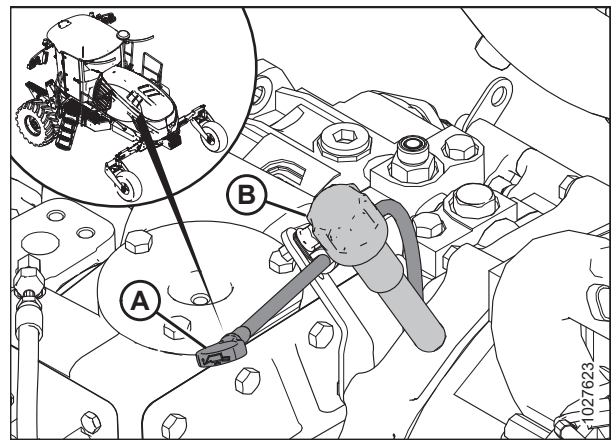

Figure 5.43: Gearbox Dipstick and Breather

MAINTENANCE AND SERVICING

8. Add lubricant until the oil level is between the ADD (A) and FULL (B) marks on the dipstick. For lubricant specifications, refer to the inside back cover.
9. Reinstall dipstick and breather.
10. Operate the engine at low idle and check for leaks at the check plug and drain plug.

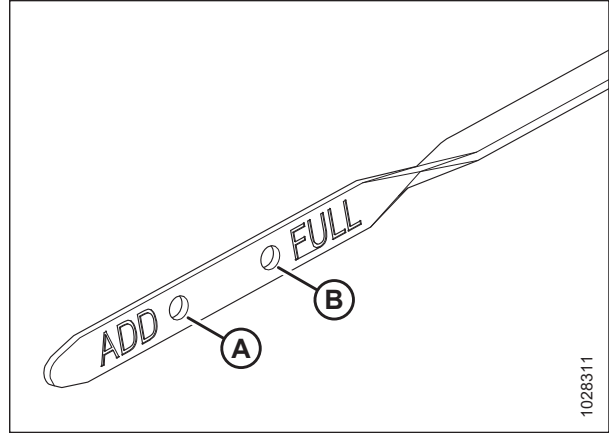

Figure 5.44: Bottom End of Dipstick

5.6.7 Changing Wheel Drive Lubricant – 10 Bolt

The wheel drive lubricant should be changed after the first 50 hours and every 1000 hours or annually, whichever occurs first. Change the lubricant when it is warm.

WARNING

To avoid bodily injury or death from unexpected startup of the machine, always stop the engine and remove the key from the ignition before leaving the operator's seat for any reason.

1. Park windrower on level ground and position windrower so drain plug (B) is at the lowest point.
2. Shut down the windrower and remove key from ignition.
3. Place a container (about 2 liters [2 quarts]) under the lower drain plug (B).
4. Remove plugs (A) and (B), and drain lubricant into container.
5. Dispose of oil in a manner that complies with local rules and regulations.

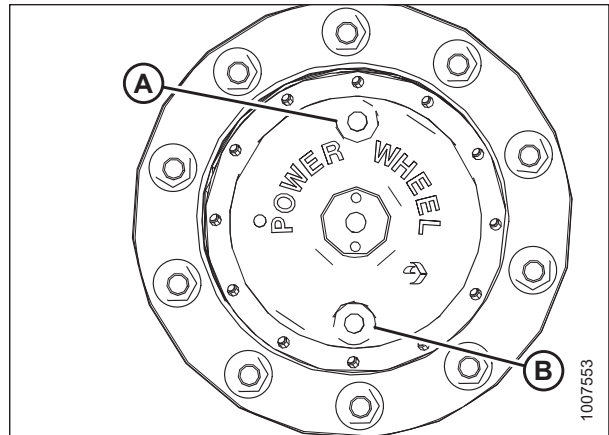

Figure 5.45: Drive Wheel

MAINTENANCE AND SERVICING

6. After the lubricant has drained completely, position the windrower so that ports (A) and (B) on wheel are horizontally level with the center of hub (C) as shown.
7. Add lubricant. For instructions, refer to [5.10.5 Adding Wheel Drive Lubricant – 10 Bolt](#), page 364.
8. Reinstall all plugs.

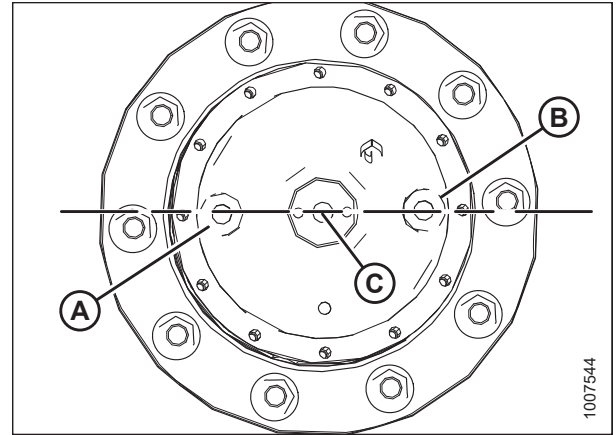

Figure 5.46: Drive Wheel

5.6.8 Changing Wheel Drive Lubricant – 12 Bolt (Optional)

The wheel drive lubricant should be changed after the first 50 hours and every 1000 hours or annually, whichever occurs first. Change the lubricant when it is warm.

WARNING

To avoid bodily injury or death from unexpected startup of the machine, always stop the engine and remove the key from the ignition before leaving the operator's seat for any reason.

1. Park the windrower on level ground and position the drive wheel so fill/drain plug (A) is at the lowest point.
2. Shut down the engine, and remove the key from the ignition.
3. Place a container (about 5 liters [5.3 quarts]) under the fill/drain plug (A).
4. Remove fill/drain plug (A) and check plug (B), and drain lubricant into container.
5. Dispose of oil in a manner that complies with local rules and regulations.

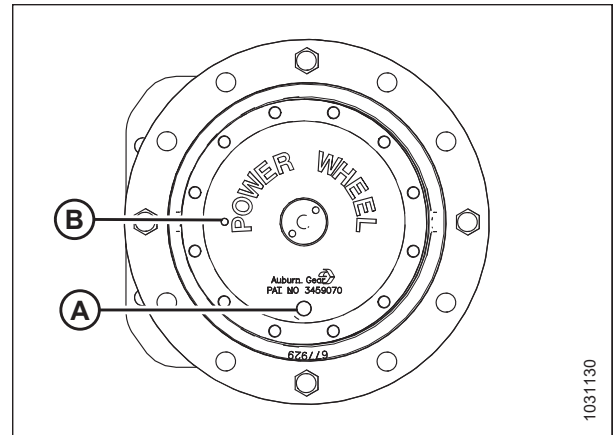

Figure 5.47: Wheel Drive – 12 Bolt

MAINTENANCE AND SERVICING

6. After the lubricant has drained completely, rotate the wheel drive until fill/drain plug (A) is vertically centered with the hub, and check port (B) on wheel drive is horizontally level with the center of the hub.
7. Add lubricant. For instructions, refer to [5.10.6 Adding Wheel Drive Lubricant – 12 Bolt \(Optional\)](#), page 365.
8. Reinstall check plug (B) and torque to 7.5 Nm (6 lbf-ft).
9. Reinstall fill/drain plug (A) and torque to 22 Nm (18 lbf-ft).

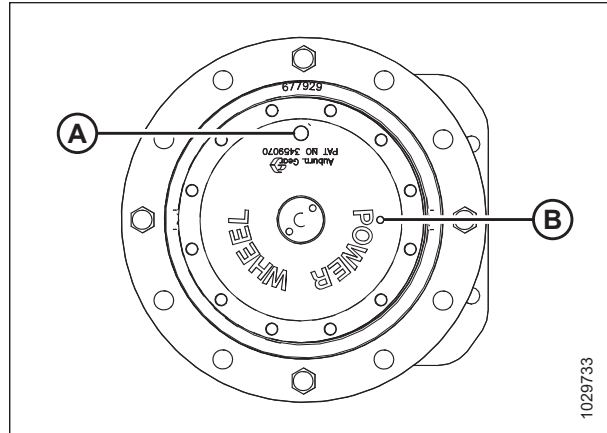

Figure 5.48: Wheel Drive – 12 Bolt

5.6.9 Return Oil Filter

The return oil filter removes particulate contaminants from the oil returning from the fan drive, lift circuits, and the drive circuits. It must be changed after the first 50 hours and then at 500-hour intervals. Follow the service schedule on the Harvest Performance Tracker (HPT) display.

Removing Return Oil Filter

WARNING

To avoid bodily injury or death from unexpected startup of the machine, always stop the engine and remove the key from the ignition before leaving the operator's seat for any reason.

DANGER

Avoid high-pressure fluids. Escaping fluid can penetrate the skin causing serious injury.

1. Shut down the engine, and remove the key from the ignition.
2. Locate return filter (A) under the left platform.
3. Clean around head of filter (A).
4. Place a container beneath filter (A) to collect any oil that may leak out.
5. Unscrew filter (A) with a filter wrench.
6. Dispose of used oil and filter in a manner that complies with local rules and regulations.

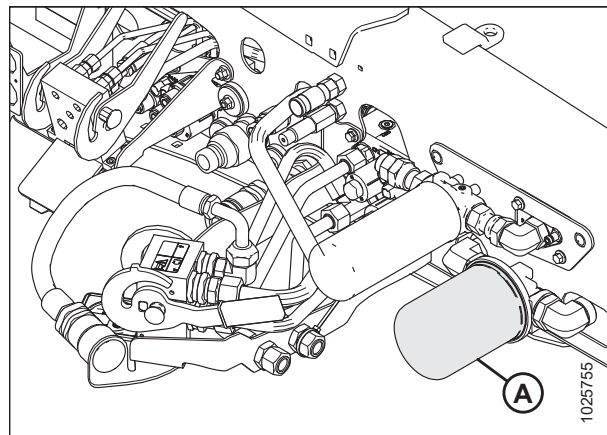

Figure 5.49: Return Filter

NOTE:

Image showing filter head removed to show component clarity.

7. Remove and discard gasket (C) from groove (B) in filter head (A).

NOTE:

Filter (D) is shown to provide context.

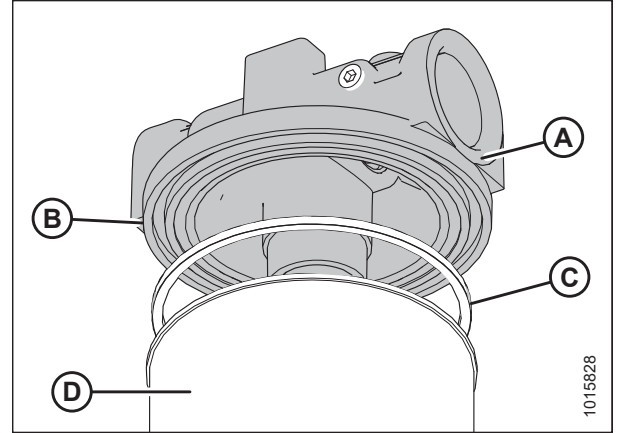

Figure 5.50: Return Filter

Installing Return Oil Filter

NOTE:

For filter specifications, refer to [5.1.4 Filter Part Numbers, page 297](#).

NOTE:

Image shows filter head removed for component clarity.

1. Clean gasket groove (B) in filter head (A).
2. Apply a thin film of clean oil to new filter gasket (C).

IMPORTANT:

Do **NOT** pre-fill filter before installation as this may potentially introduce unfiltered oil into the system.

3. Install new gasket (C) into groove (B) in filter head (A).
4. Screw new filter (D) onto the filter head until the gasket just contacts the filter.

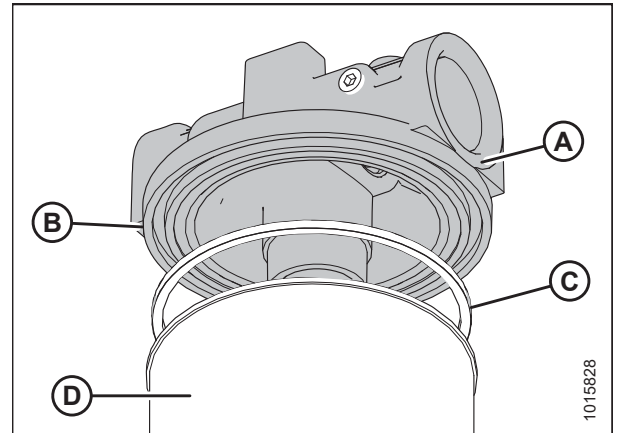

Figure 5.51: Return Filter

5. Tighten filter (A) an additional 3/4 turn by hand.

IMPORTANT:

Do **NOT** use a filter wrench to install oil filter. Overtightening can damage gasket and filter.

6. Check hydraulic fluid levels. For instructions, refer to [5.7.3 Checking Hydraulic Oil, page 337](#). For capacity level, refer to the inside back cover.

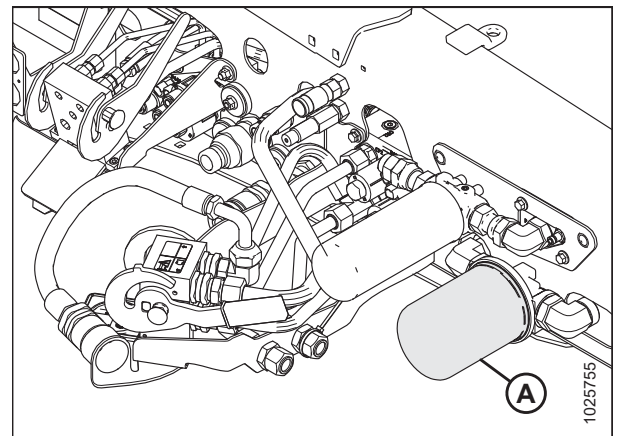

Figure 5.52: Return Filter

5.6.10 Charge Filter

The charge filter removes particulate contaminants from the oil before the oil is directed into the traction and header drive pumps. The oil maintains a positive pressure and is continuously supplied in these closed circuits during operation. The charge filter has a high-pressure bypass of 345 kPa (50 psi) that allows oil to bypass the filter element during cold temperatures and when the filter element is heavily loaded.

The charge filter must be replaced at regular intervals. The filter telltale is displayed on the Harvest Performance Tracker (HPT). The charge filter must be changed after first 50 hours and every 500 hours thereafter. Follow the service schedule on the HPT.

Refer to the following procedures to change the charge filter:

- [Removing Charge Filter, page 332.](#)
- [Installing Charge Filter, page 333.](#)

Removing Charge Filter

WARNING

To avoid bodily injury or death from unexpected startup of the machine, always stop the engine and remove the key from the ignition before leaving the operator's seat for any reason.

WARNING

Avoid high-pressure fluids. Escaping fluid can penetrate the skin causing serious injury.

1. Shut down the engine, and remove the key from the ignition.
2. Open the platform. For instructions, refer to [5.4.1 Opening Platform, page 304.](#)
3. Clean around head of the filter.
4. Place a container beneath the filter to collect any oil that may leak out.
5. Unscrew filter (A) with a filter wrench.
6. Dispose of used oil and filter in a manner that complies with local rules and regulations.

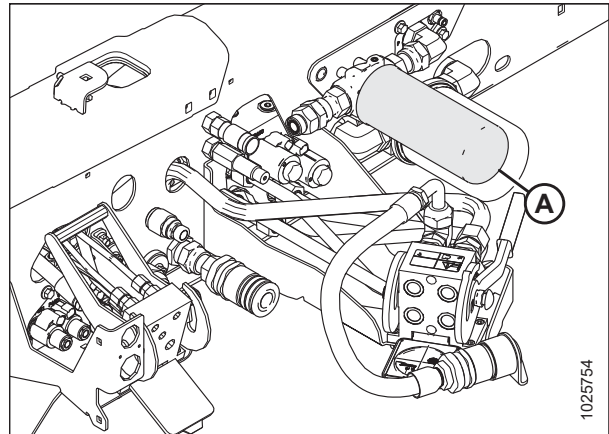

Figure 5.53: Charge Filter

Installing Charge Filter

NOTE:

For charge filter replacement part number, refer to [5.1.4 Filter Part Numbers, page 297](#).

1. Clean the gasket surface of the filter head.
2. Apply a thin film of clean oil to the filter gasket.

IMPORTANT:

Do **NOT** pre-fill filter before installation as this may potentially introduce unfiltered oil into the system.

3. Screw new filter (A) onto the mount until the gasket just contacts the filter head.
4. Tighten filter an additional 1/2 turn by hand.

IMPORTANT:

Do **NOT** use a filter wrench to install oil filter. Overtightening can damage gasket and filter.

5. Check hydraulic fluid levels. For instructions, refer to [5.7.3 Checking Hydraulic Oil, page 337](#). For capacity level, refer to the inside back cover.

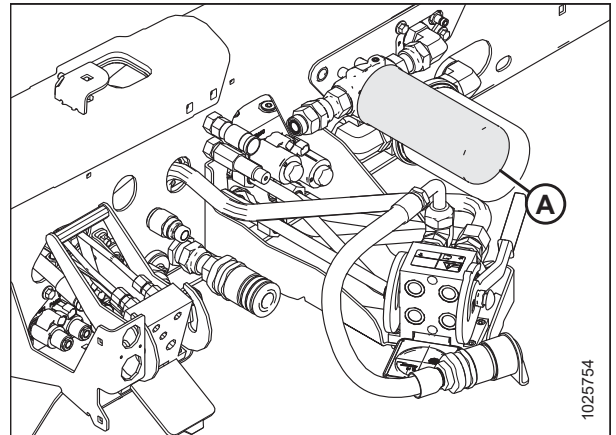

Figure 5.54: Charge Filter

5.7 Every 10 Hours or Daily

Complete the following maintenance tasks every 10 hours of operation or daily, whichever occurs first.

- Check engine oil level. For instructions, refer to *5.7.1 Checking Engine Oil Level, page 334*.
- Check engine coolant level. For instructions, refer to *5.7.5 Checking Engine Coolant Level, page 341*.
- Check hydraulic oil level. For instructions, refer to *5.7.3 Checking Hydraulic Oil, page 337*.
- Check tire inflation. For instructions, refer to *5.7.4 Checking Tire Pressures, page 338*.
- Check hydraulic hoses and lines for leaks. For instructions, refer to *5.7.6 Hoses and Lines, page 342*.
- Drain fuel filter water trap. For instructions, refer to *5.7.2 Fuel/Water Separator, page 336*.
- Clean radiator, hydraulic oil cooler, charge air cooler, and A/C condenser. For instructions, refer to *5.9.2 Cleaning Cooler Module, page 350*.
- Fill fuel tank. For instructions, refer to *Filling Fuel Tank, page 115*.
- Check diesel exhaust fluid (DEF) level. For instructions, refer to *3.17 Harvest Performance Tracker Display, page 77*.
- Check engine gearbox lubricant level. For instructions, refer to *5.7.7 Checking Engine Gearbox Lubricant Level and Adding Lubricant, page 343*.

5.7.1 Checking Engine Oil Level

Check the engine oil level frequently and watch for any signs of leakage.

WARNING

To avoid bodily injury or death from unexpected startup of the machine, always stop the engine and remove the key from the ignition before leaving the operator's seat for any reason.

NOTE:

During the break-in period, a higher than usual oil consumption should be considered normal.

NOTE:

Oil can be checked without opening the hood.

1. Operate the engine at low idle and check for leaks at the filter and drain plug.
2. Shut down the engine, and remove the key from the ignition.
3. Wait about 5 minutes.
4. Remove dipstick (A) by turning it counterclockwise to unlock.
5. Wipe the dipstick clean and reinsert it into engine.

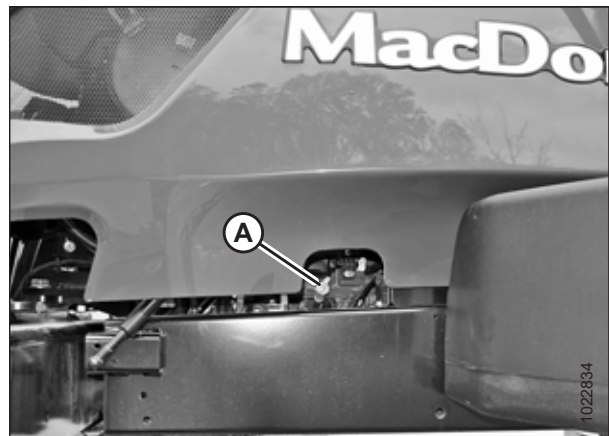

Figure 5.55: Dipstick Location

- Remove the dipstick again and check the oil level. The oil level should be between LOW (L) and HIGH (H). If below the LOW mark, add oil.

NOTE:

Adding 1.9 liters (2 U.S. quarts) will raise the level from LOW to HIGH. To add oil, refer to [Adding Engine Oil, page 335](#).

- Replace the dipstick and turn it clockwise to lock.

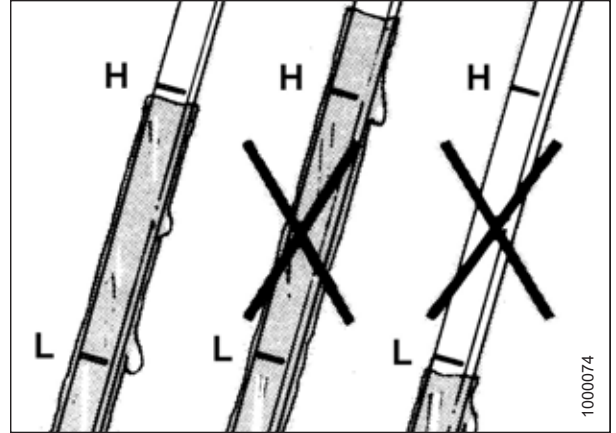

Figure 5.56: Engine Oil Level

Adding Engine Oil

WARNING

To avoid bodily injury or death from unexpected startup of the machine, always stop the engine and remove the key from the ignition before leaving the operator's seat for any reason.

- Open the hood. For instructions, refer to [5.3.1 Opening Hood, page 302](#).
- Clean around filler cap (A) and remove by turning it counterclockwise.
- Carefully pour in of new oil. A funnel is recommended to avoid spillage. Refer to the inside back cover for oil specifications.

CAUTION

Do NOT fill above the HIGH mark.

- Replace oil filler cap (A) and turn it clockwise until snug.

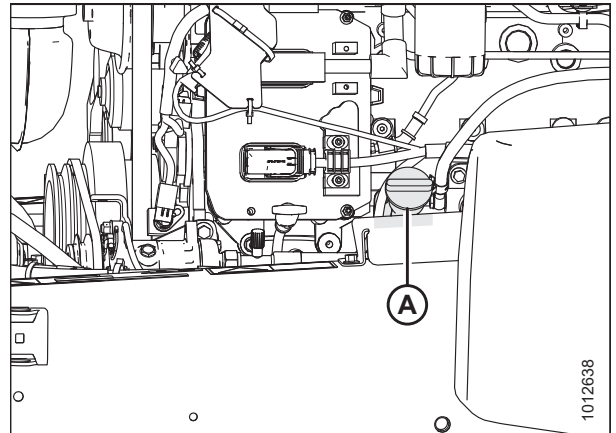

Figure 5.57: Oil Filler Cap

- Check the oil level. For instructions, refer to [5.7.1 Checking Engine Oil Level, page 334](#).
- Close the hood. For instructions, refer to [5.3.2 Closing Hood, page 303](#).

5.7.2 Fuel/Water Separator

A fuel/water separator is incorporated into the primary fuel filter. The separator is equipped with a drain and a sensor that detects water in the fuel and displays an alert on the HPT display. Drain the water and sediment from the separator daily or at any time the Water In Fuel (WIF) light illuminates on the HPT display.

To remove water from the fuel system, refer to *Removing Water from Fuel System, page 336*.

Removing Water from Fuel System

WARNING

To avoid bodily injury or death from unexpected startup of the machine, always stop the engine and remove the key from the ignition before leaving the operator's seat for any reason.

1. Shut down the engine, and remove the key from the ignition.
2. Open the hood. For instructions, refer to *5.3.1 Opening Hood, page 302*.
3. Place a container under the filter (A) to catch spilled fluid.
4. Turn drain valve (C) by hand 1 1/2 to 2 turns counterclockwise until draining occurs.
5. Drain the filter sump of water and sediment until clear fuel is visible.
6. Turn the valve clockwise to close the drain.
7. Dispose of fluid safely.
8. Close the hood. For instructions, refer to *5.3.2 Closing Hood, page 303*.

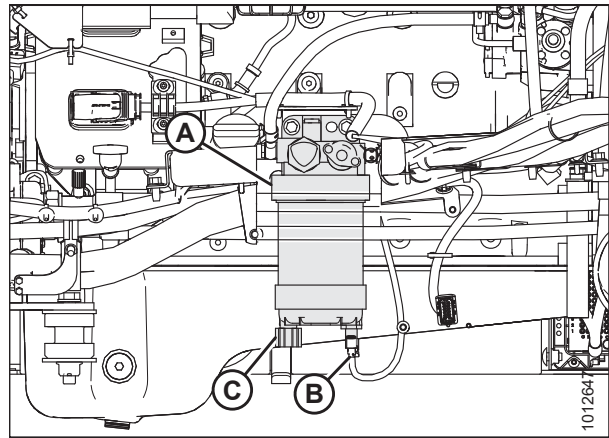

Figure 5.58: Fuel System

- A - Primary Fuel Filter
- B - Water in Fuel (WIF) Sensor
- C - Drain Valve

5.7.3 Checking Hydraulic Oil

Hydraulic oil is used to transmit force under high pressure. The oil also lubricates, cools, and cleans the system, therefore the cleanliness and quality of the oil is highly important to ensure long system life. It is extremely important to avoid contamination when service and regular maintenance is performed.

⚠ WARNING

To avoid bodily injury or death from unexpected startup of the machine, always stop the engine and remove the key from the ignition before leaving the operator's seat for any reason.

⚠ WARNING

Avoid high-pressure fluids. Escaping fluid can penetrate the skin causing serious injury.

1. Park the windrower on a level surface.
2. Lower the header fully.
3. Lower the reel fully.
4. Shut down the engine, and remove the key from the ignition.
5. Locate sight glass (A) on the right side of the tank. It indicates the oil level and any signs of contamination.

NOTE:

No oil in the sight glass indicates that the oil level is below the add mark on the dipstick. The sight glass is viewable with hood open or closed.

6. Ensure the hydraulic oil level is between the low and full indicator marks.
7. If more oil is required to maintain the level between low and full indicator marks, refer to [5.13.3 Filling Hydraulic Oil, page 384](#).

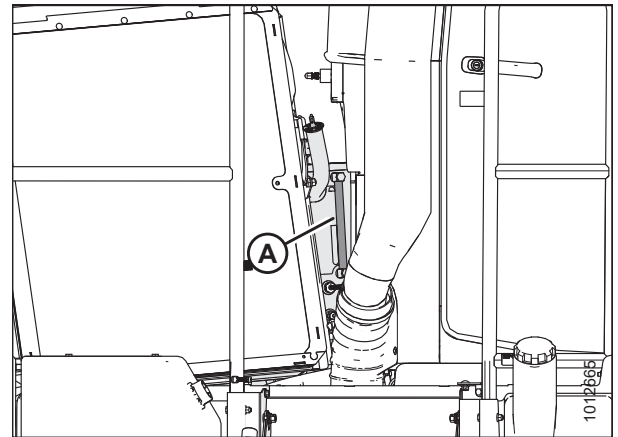

Figure 5.59: Hydraulic Oil Sight Glass

5.7.4 Checking Tire Pressures

Check tire pressures with a gauge.

Caster Wheel Tires: Inflate all caster wheel tires (B) to 110 kPa (16 psi).

Drive Wheel Tires: For optimal performance, drive wheel (A) tire pressures are determined by tire type, header size, and additional options. Refer to the following table:

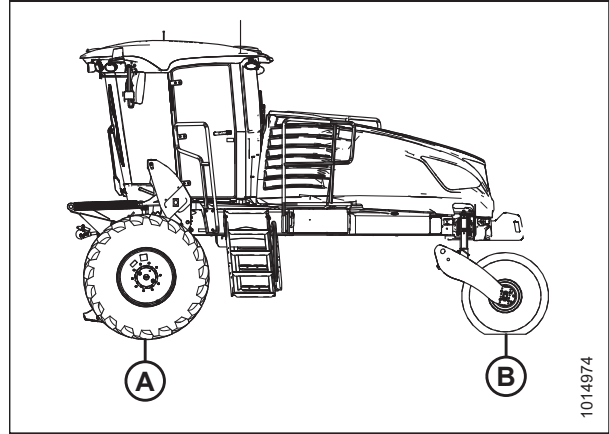

Figure 5.60: Windrower Tires

Table 5.4 Drive Tire Inflation Specifications

Header Type	Description	Installed Options	Weight Kit	Tire Type	Pressure kPa (psi)
Draper Header					
D115X single reel	4.6 m (15 ft.), double knife, timed	—	—	Bar	138 (20)
D115X single reel	4.6 m (15 ft.), double knife, timed	—	—	Turf	138 (20)
D120X single reel	6.1 m (20 ft.), double knife, timed	—	—	Bar	138 (20)
D120X single reel	6.1 m (20 ft.), double knife, timed	—	—	Turf	138 (20)
D125X single reel	7.6 m (25 ft.), double knife, timed	—	—	Bar	159 (23)
D125X single reel	7.6 m (25 ft.), double knife, timed	—	—	Turf	159 (23)
D130XL single reel	9.1 m (30 ft.), double knife, timed	Transport	1	Bar	200 (29)
D130XL single reel	9.1 m (30 ft.), double knife, timed	Transport	1	Turf	241 (35)
D130XL single reel	9.1 m (30 ft.), double knife, timed	Transport + upper cross auger + vertical knives	1	Bar	241 (35)
D130XL single reel	9.1 m (30 ft.), double knife, timed	Transport + upper cross auger + vertical knives	1	Turf	241 (35)
D135XL single reel	10.7 m (35 ft.), double knife, untimed	Base	2	Bar	200 (29)
D135XL single reel	10.7 m (35 ft.), double knife, untimed	Base	2	Turf	241 (35)

MAINTENANCE AND SERVICING

Table 5.4 Drive Tire Inflation Specifications (continued)

Header Type	Description	Installed Options	Weight Kit	Tire Type	Pressure kPa (psi)
D135XL single reel	10.7 m (35 ft.), double knife, untimed	Transport	2	Bar	241 (35)
D135XL single reel	10.7 m (35 ft.), double knife, untimed	Transport	2	Turf	241 (35)
D135XL single reel	10.7 m (35 ft.), double knife, untimed	Transport + upper cross auger + vertical knives	3	Bar	241 (35)
D135XL single reel	10.7 m (35 ft.), double knife, untimed	Transport + upper cross auger + vertical knives	3	Turf	241 (35)
D135XL double reel	10.7 m (35 ft.), double knife, untimed	Base	2	Bar	221 (32)
D135XL double reel	10.7 m (35 ft.), double knife, untimed	Base	2	Turf	241 (35)
D135XL double reel	10.7 m (35 ft.), double knife, untimed	Transport	2	Bar	241 (35)
D135XL double reel	10.7 m (35 ft.), double knife, untimed	Transport	2	Turf	241 (35)
D135XL double reel	10.7 m (35 ft.), double knife, untimed	Transport + upper cross auger + vertical knives	3	Bar	283 (41)
D135XL double reel	10.7 m (35 ft.), double knife, untimed	Transport + upper cross auger + vertical knives	3	Turf	241 (35)
D140XL double reel	12.2 m (40 ft.), double knife, untimed	Base	2	Bar	241 (35)
D140XL double reel	12.2 m (40 ft.), double knife, untimed	Base	2	Turf	241 (35)
D140XL double reel	12.2 m (40 ft.), double knife, untimed	Transport	2	Bar	241 (35)
D140XL double reel	12.2 m (40 ft.), double knife, untimed	Transport	2	Turf	241 (35)
D140XL double reel	12.2 m (40 ft.), double knife, untimed	Transport + upper cross auger + vertical knives	3	Bar	283 (41)
D140XL double reel	12.2 m (40 ft.), double knife, untimed	Transport + upper cross auger + vertical knives	3	Turf	241 (35)
D145XL double reel	13.7 m (45 ft.), double knife, untimed	Base	2	Bar	241 (35)
D145XL double reel	13.7 m (45 ft.), double knife, untimed	Base	2	Turf	241 (35)
D145XL double reel	13.7 m (45 ft.), double knife, untimed	Transport	3	Bar	262 (38)
D145XL double reel	13.7 m (45 ft.), double knife, untimed	Transport	3	Turf	241 (35)
D145XL double reel	13.7 m (45 ft.), double knife, untimed	Transport + upper cross auger + vertical knives	3	Bar	283 (41)

MAINTENANCE AND SERVICING

Table 5.4 Drive Tire Inflation Specifications (continued)

Header Type	Description	Installed Options	Weight Kit	Tire Type	Pressure kPa (psi)
D145XL double reel	13.7 m (45 ft.), double knife, untimed	Transport + upper cross auger + vertical knives	3	Turf	241 (35)
Rotary Disc Header					
R85	4.9 m (16 ft.)	Base	—	Bar or Turf	200 (29)
R113	4 m (13 ft.)	No Conditioner	—	Bar or Turf	138 (20)
R113	4 m (13 ft.)	Steel or Poly Roll	—	Bar	179 (26)
R113	4 m (13 ft.)	Steel or Poly Roll	—	Turf	159 (23)
R216	4.9 m (16 ft.)	Steel or Poly Roll	—	Bar	200 (29)
R216	4.9 m (16 ft.)	Steel or Poly Roll	—	Turf	200 (29)
Auger Header					
A40DX	4.9 m (16 ft.)	—	—	Bar	200 (29)
A40DX	4.9 m (16 ft.)	—	—	Turf	200 (29)
A40DX GSS	4.9 m (16 ft.) (Grass Seed)	—	—	Bar	159 (23)
A40DX GSS	4.9 m (16 ft.) (Grass Seed)	—	—	Turf	159 (23)
A40DX	5.5 m (18 ft.)	—	—	Bar	200 (29)
A40DX	5.5 m (18 ft.)	—	—	Turf	220 (32)

5.7.5 Checking Engine Coolant Level

Check the coolant level in the pressurized coolant tank daily.

WARNING

To avoid bodily injury or death from unexpected startup of the machine, always stop the engine and remove the key from the ignition before leaving the operator's seat for any reason.

NOTE:

Ensure the engine has cooled down prior to checking.

1. Shut down the engine, and remove the key from the ignition.
2. Open the hood. For instructions, refer to [5.3.1 Opening Hood, page 302](#).
3. Locate the coolant tank.
4. The tank has a MAX and MIN COLD line marker. Check to make sure the coolant level is at MAX COLD line (A). If it is too low, add coolant. For specifications, refer to the inside back cover.

NOTE:

When checking coolant level, use the MAX COLD line on the side of tank that faces cab for an accurate measurement.

5. Close the hood. For instructions, refer to [5.3.2 Closing Hood, page 303](#).

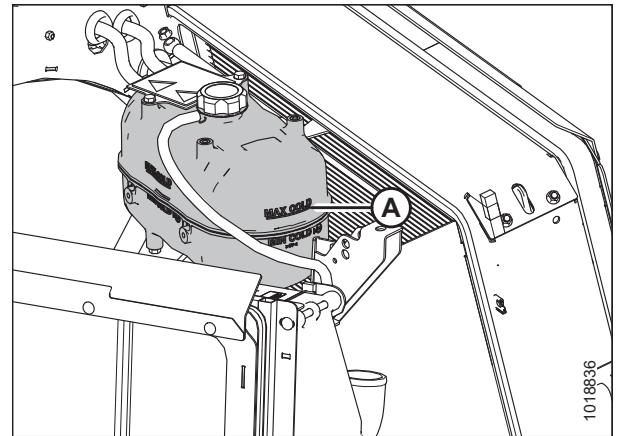

Figure 5.61: Coolant Tank

5.7.6 Hoses and Lines

Check hydraulic hoses and lines daily for signs of leaks.

WARNING

- Avoid high-pressure fluids. Escaping fluid can penetrate the skin causing serious injury.
- Relieve pressure before disconnecting hydraulic lines. Tighten all connections before applying pressure.
- Keep hands and body away from pin-holes and nozzles which eject fluids under high pressure.
- If ANY fluid is injected into the skin, it must be surgically removed within a few hours by a Doctor familiar with this type of injury or gangrene may result.
- Use a piece of cardboard or paper to search for leaks.
- Any service components must be genuine MacDon parts.
- All connections must be properly torqued. Refer to [8.1 Torque Specifications, page 459](#).

IMPORTANT:

- Keep hydraulic coupler tips and connectors clean. Dust, dirt, water, and foreign material are the major causes of hydraulic system damage.
- DO **NOT** attempt to service hydraulic system in the field. Make every effort to prevent the hydraulic system from being contaminated during overhaul.



Figure 5.62: Hydraulic Pressure Hazard

5.7.7 Checking Engine Gearbox Lubricant Level and Adding Lubricant

Check lubricant level every day.

WARNING

To avoid bodily injury or death from unexpected startup of the machine, always stop the engine and remove the key from the ignition before leaving the operator's seat for any reason.

CAUTION

Park on a flat, level surface with the header on the ground, the ground speed lever (GSL) in PARK position, and the steering wheel in locked position (centered). Wait for the HPT to beep and display a red P symbol to confirm the park brakes have engaged.

1. Park the windrower on level ground, shut down engine, and remove key.

NOTE:

If engine is hot, wait 10 minutes before checking level to allow lubricant to cool and settle in the sump.

2. Open the hood. For instructions, refer to [5.3.1 Opening Hood, page 302](#).
3. Remove dipstick (A) and check lubricant level.

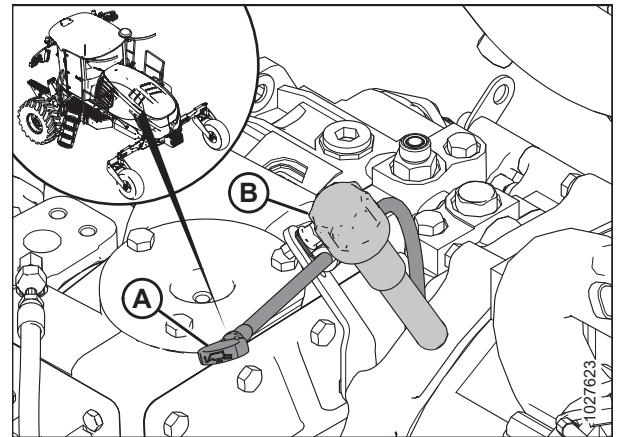

Figure 5.63: Gearbox Lubricant Dipstick

4. If the lubricant level is at or below ADD mark (A) on the dipstick, remove breather ([B] in Figure) and add gearbox lubricant until it is between ADD mark (A) and FULL mark (B) on the dipstick.

For lubrication specifications, refer to the inside back cover.

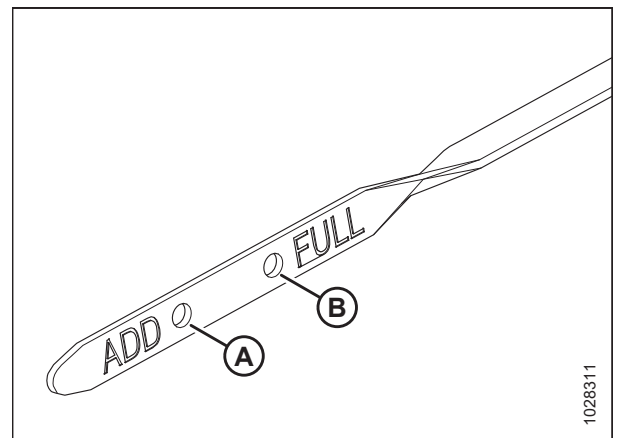

Figure 5.64: Bottom End of Dipstick

5.8 Every 50 Hours

Complete the following maintenance tasks every 50 hours of operation.

- Clean the cab fresh air intake filter. For instructions, refer to [5.8.1 Fresh Air Intake Filter, page 344](#).
- Grease caster bearings and pivots. For instructions, refer to [5.8.2 Greasing the Windrower, page 347](#).
- Grease top lift link pivots. For instructions, refer to [5.8.2 Greasing the Windrower, page 347](#).

5.8.1 Fresh Air Intake Filter

The fresh air intake filter is located outside the lower right rear of cab (A), and should be serviced every 50 hours under normal conditions and more frequently in severe conditions. Refer to [5.1.4 Filter Part Numbers, page 297](#) for the appropriate part number.

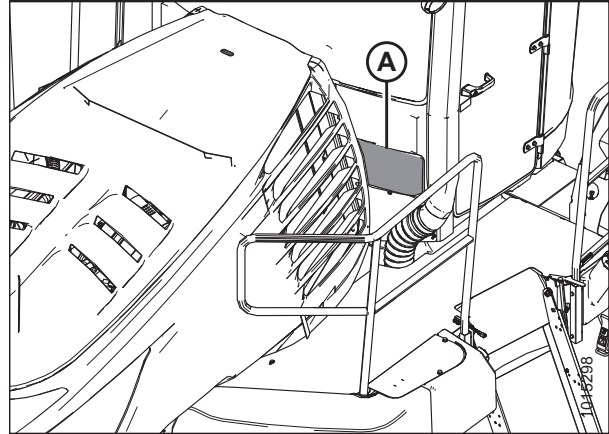

Figure 5.65: Fresh Air Intake Filter Location

Removing Fresh Air Intake Filter

WARNING

To avoid bodily injury or death from unexpected startup of the machine, always stop the engine and remove the key from the ignition before leaving the operator's seat for any reason.

1. Shut down the engine, and remove the key from the ignition.
2. Open the hood. For instructions, refer to [5.3.1 Opening Hood, page 302](#).
3. Rotate latch (A) counterclockwise to loosen, and remove fresh air filter door (B).

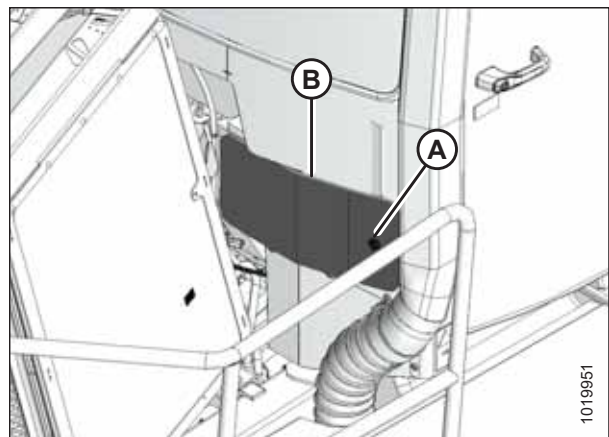

Figure 5.66: Fresh Air Filter Door

MAINTENANCE AND SERVICING

4. Turn knob (A) counterclockwise, and remove it.
5. Remove air filter retainer (B).
6. Remove air filter (C).

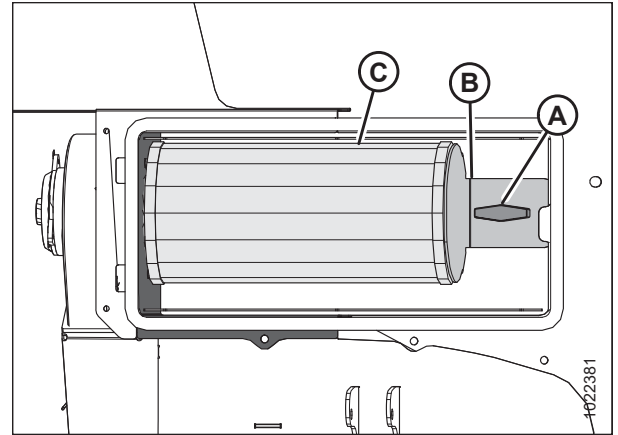

Figure 5.67: Fresh Air Intake Filter

Inspecting and Cleaning Fresh Air Intake Filter Element

1. Tap the sides of the filter element gently to loosen dirt. Do **NOT** tap element against a hard surface.
2. Using a dry element cleaner gun, clean element with compressed air.

IMPORTANT:

Air pressure must **NOT** exceed 414 kPa (60 psi). Do **NOT** direct air against outside of element, as dirt might be forced through to the inside.

3. Hold the air nozzle next to the filter element's inner surface and move up and down the pleats.
4. Repeat previous steps to remove additional dirt as required.
5. Hold a bright light inside the element and check carefully for holes. Discard any element that shows the slightest hole.
6. Check outer screen for dents. Vibration would quickly wear a hole in the filter.
7. Check filter gasket for cracks, tears, or other signs of damage. If gasket is damaged or missing, replace element.

Installing Fresh Air Intake Filter

Refer to *5.1.4 Filter Part Numbers, page 297* for part number.

1. Clean interior of fresh air intake box (A).

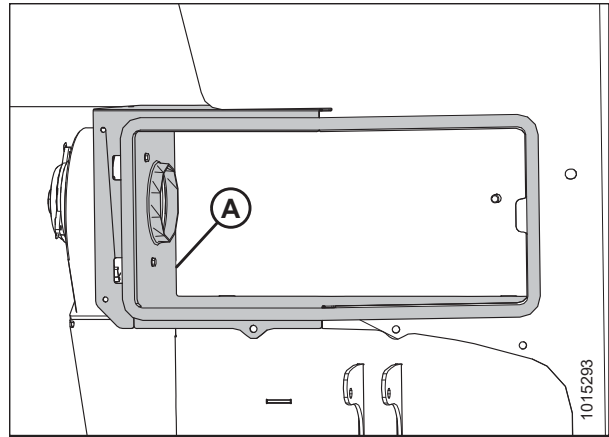

Figure 5.68: Fresh Air Intake Box

2. Install air filter (A) onto fresh air box panel (B).

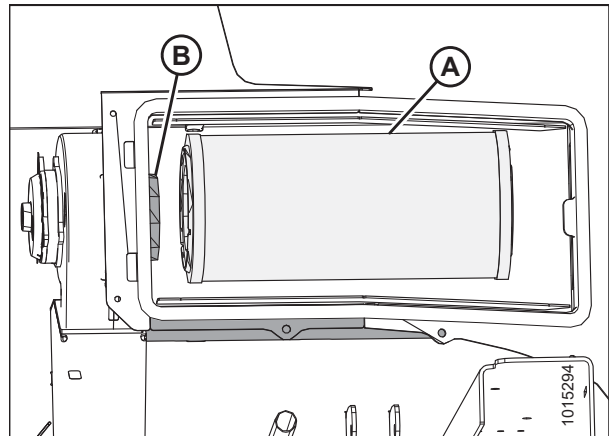

Figure 5.69: Fresh Air Intake Filter

3. Secure air filter (C) with retainer (B).
4. Install knob (A), and turn clockwise to tighten.

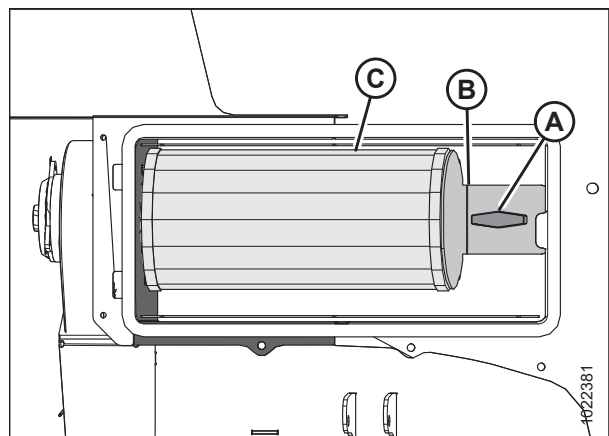

Figure 5.70: Fresh Air Intake Filter

MAINTENANCE AND SERVICING

5. Insert tabs on fresh air filter door into slots on fresh air box, and rotate latch (A) clockwise to secure door (B).

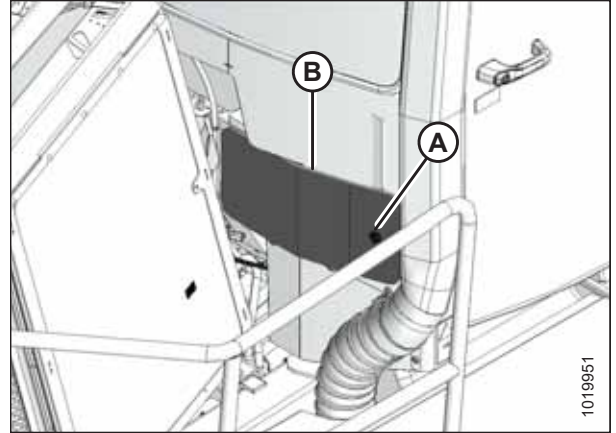

Figure 5.71: Fresh Air Intake Filter Cover

5.8.2 Greasing the Windrower

WARNING

To avoid personal injury, before servicing the windrower or opening drive covers, follow procedures in the SAFETY section. Refer to [1 Safety, page 1](#).

The greasing points are marked on the machine by decals showing a grease gun and grease interval in hours of operation.

Log hours of operation and use the Maintenance Checklist provided to keep a record of scheduled maintenance. Refer to [5.2.2 Maintenance Schedule/Record, page 299](#).

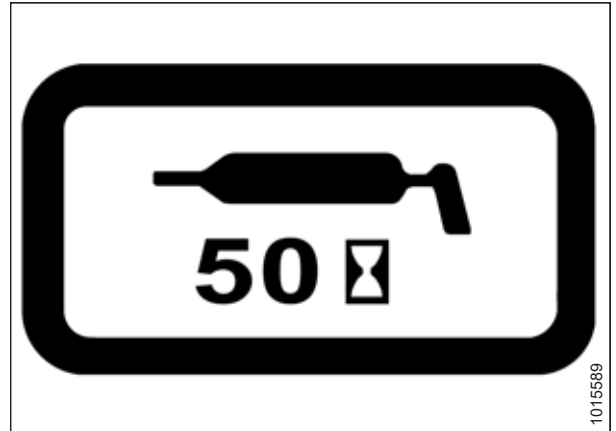

Figure 5.72: Greasing Interval Decal

Greasing Procedure

WARNING

To avoid bodily injury or death from unexpected startup of the machine, always stop the engine and remove the key from the ignition before leaving the operator's seat for any reason.

1. To avoid injecting dirt and grit, wipe grease fitting with a clean cloth before greasing.
2. Inject grease through fitting with grease gun until grease overflows fitting, except where noted. For specifications, refer to the inside back cover.
3. Leave excess grease on fitting to keep out dirt.
4. Replace any loose or broken fittings immediately.
5. If fitting will **NOT** take grease, remove and clean thoroughly. Also clean grease passageway. Replace fitting if necessary.

Grease Points

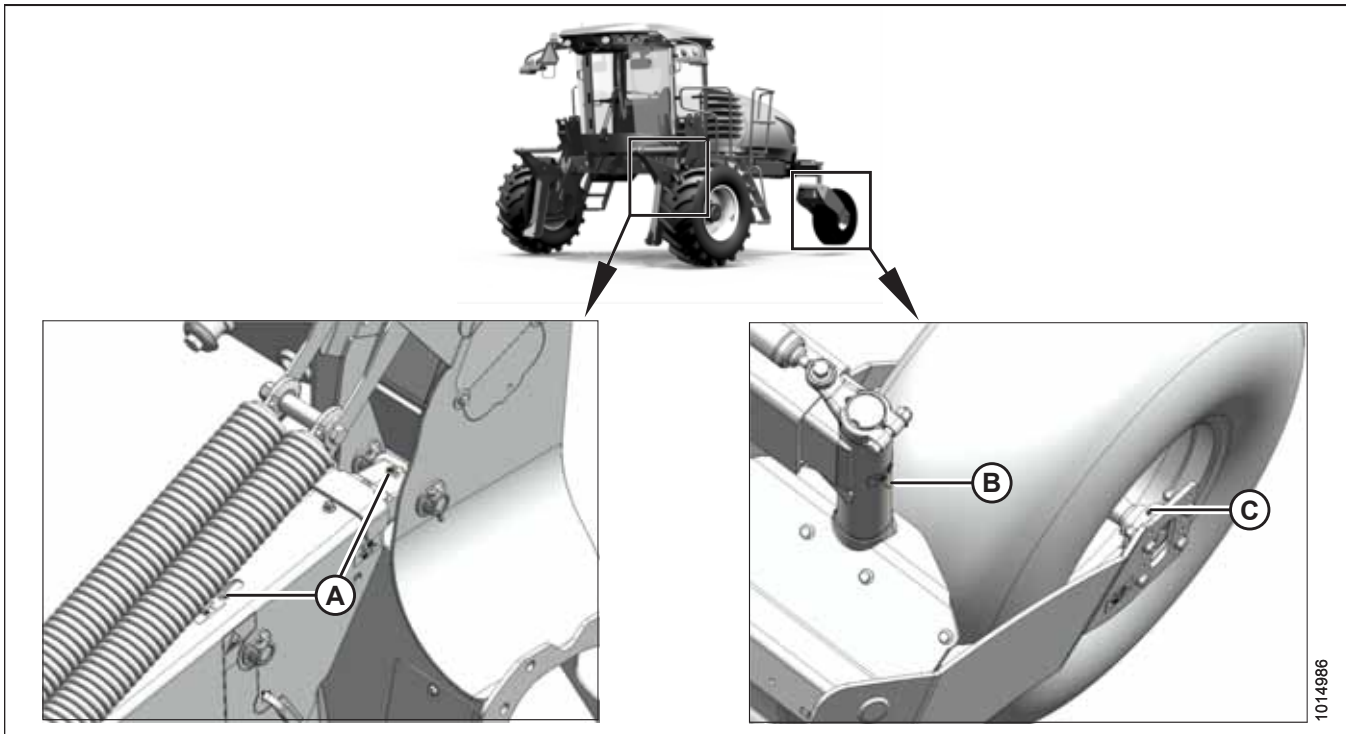

Figure 5.73: Grease Points

A - Top Link (2 Places) (Both Sides)

B - Caster Pivot (Both Sides)

C - Caster Wheel Hub (Both Sides)²¹

21. Do **NOT** overgrease. Use 1 pump of grease.

5.9 Every 100 Hours

Complete the following maintenance tasks every 100 hours of operation.

- Clean cab air return filter. For instructions, refer to [5.9.1 Servicing Return Air Filter, page 349](#).
- Clean radiator, hydraulic oil cooler, charge air cooler, and A/C condenser. Refer to [5.9.2 Cleaning Cooler Module, page 350](#).

5.9.1 Servicing Return Air Filter

The return air filter is located behind the operator's seat on the cab wall and should be serviced every 100 hours.

1. Unscrew two knobs (A) attaching cover and filter to cab wall, and remove cover and filter assembly (B).

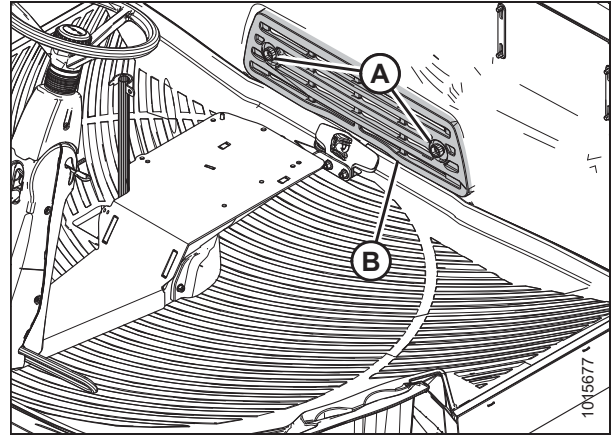

Figure 5.74: Return Air Filter

2. Separate filter (B) from cover (A).
3. Clean the electrostatic filter as follows:
 - a. Mix a solution of warm water and detergent in a suitable container so that filter (B) can soak for a few minutes.
 - b. Agitate to flush out the dirt.
 - c. Rinse with clean water, and then dry with compressed air.
 - d. Inspect filter for damage, separation, and holes. Replace if damaged. Refer to [5.1.4 Filter Part Numbers, page 297](#) for part number.
4. Assemble cleaner (B) and cover (A), and position on cab wall over opening.

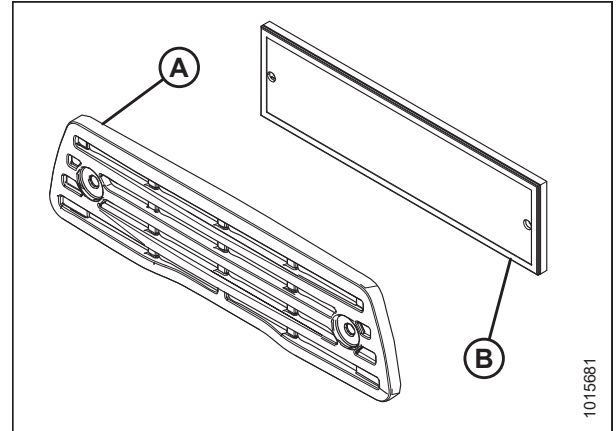

Figure 5.75: Return Air Filter

- Secure filter assembly (B) to cab wall with knobs (A).

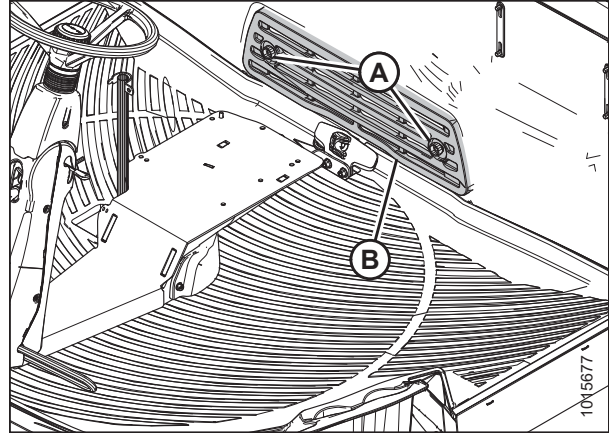

Figure 5.76: Return Air Filter

5.9.2 Cleaning Cooler Module

Clean the cooling module every 100 hours of operation. Daily cleaning may be required if operating in heavy crop conditions.

WARNING

To avoid bodily injury or death from unexpected startup of the machine, always stop the engine and remove the key from the ignition before leaving the operator's seat for any reason.

- Shut down the engine, and remove the key from the ignition.
- Open the hood. For instructions, refer to [5.3.1 Opening Hood, page 302](#).
- Proceed to the cleaning procedures. For instructions, refer to [Cleaning Right Cooling Module, page 353](#) or [Cleaning Left Cooling Module, page 350](#).

Cleaning Left Cooling Module

Clean the engine radiator, air conditioning condenser, and screen in the left cab-forward cooling module as follows.

- At left cab-forward side cooler module, push latch (A) and open engine radiator door (B).

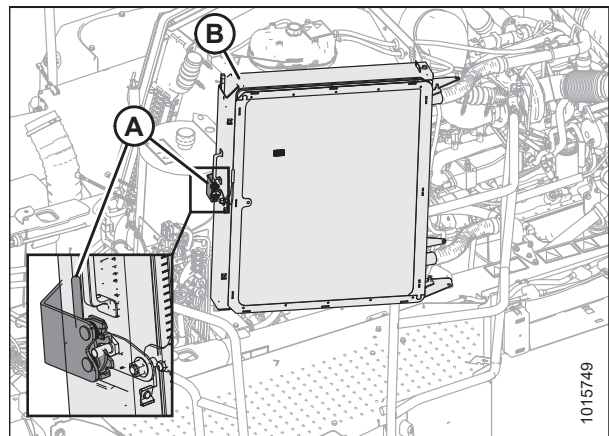

Figure 5.77: Left Cooler Module

MAINTENANCE AND SERVICING

2. Lower lever (A) to release screen/condenser door (B) from radiator (C), and open screen/condenser door (B).

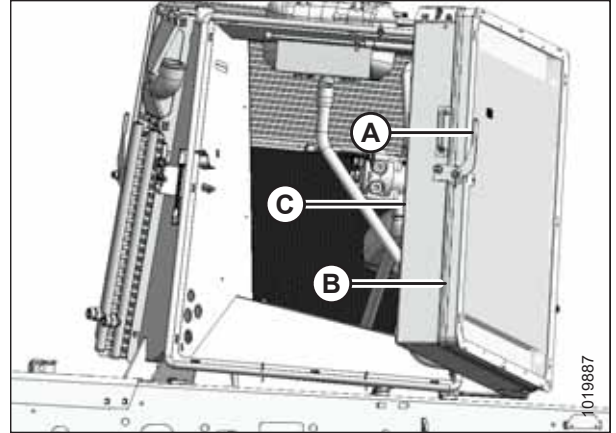

Figure 5.78: Left Cooler Module

3. Pull lever (A) up to partially-open condenser (B) away from screen (C).

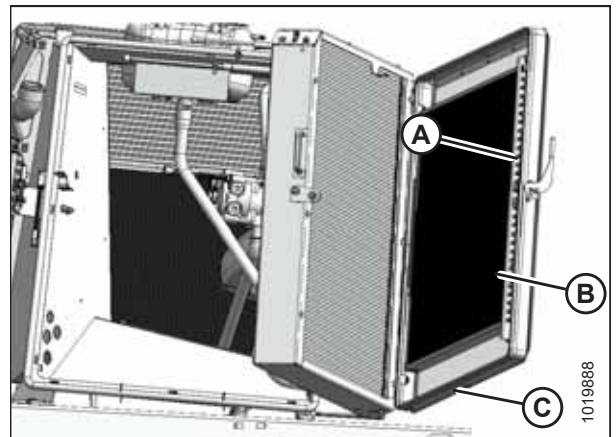

Figure 5.79: Left Cooler Module

4. Secure condenser (A) with bracket (B).
5. Clean debris from radiator (D), condenser (A), and screen (C) with compressed air.

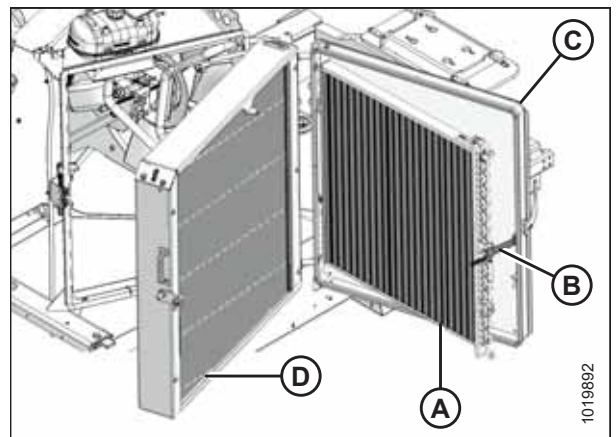

Figure 5.80: Left Cooler Module

MAINTENANCE AND SERVICING

6. Close condenser (B) into screen (C) and secure with bracket (A).

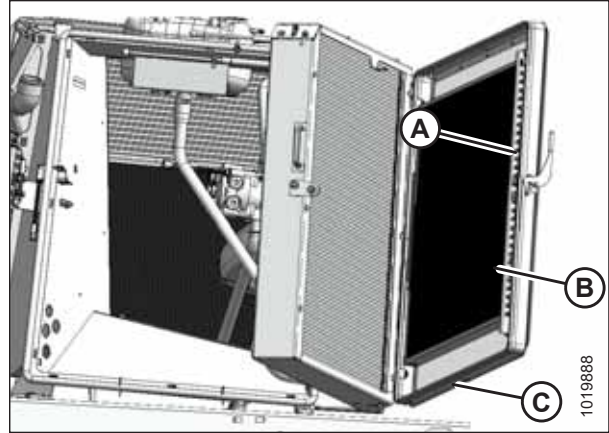

Figure 5.81: Left Cooler Module

7. Close screen/condenser door (B) onto radiator door (C) and secure with lever (A).

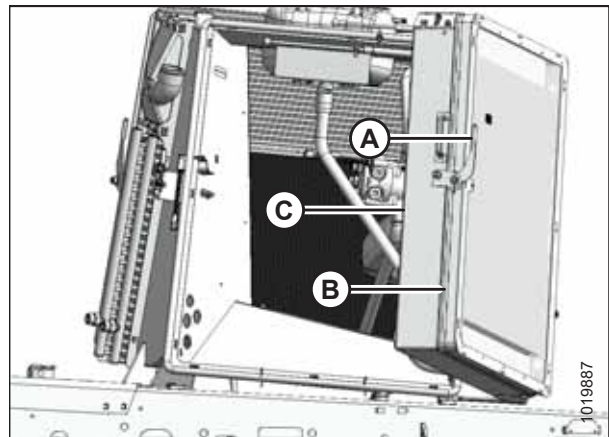

Figure 5.82: Left Cooler Module

8. Close radiator door (B) and push until latch (A) secures door (B).

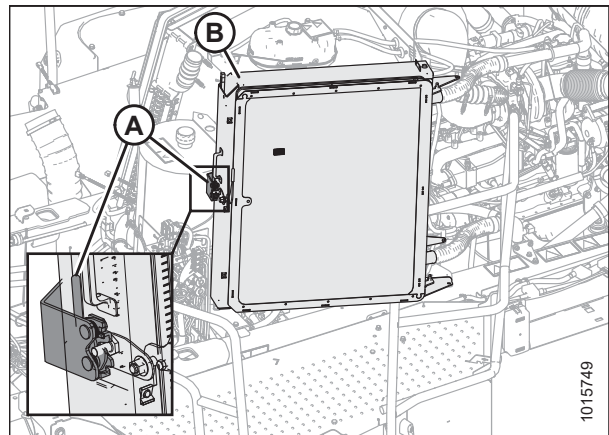

Figure 5.83: Left Cooler Module

Cleaning Right Cooling Module

Clean the coolers at the right cab-forward side of the windrower as follows.

1. At the right (cab-forward) side cooler module, pull latch handle (A) and open screen/case drain cooler door (B).

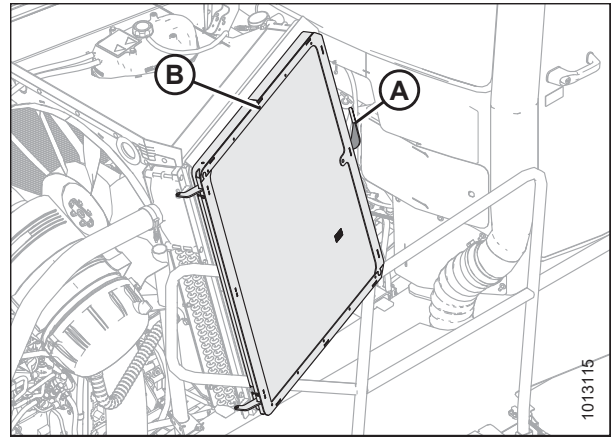

Figure 5.84: Right Cooler Module

2. At the left (cab-forward) side cooler module, push latch (A) and open engine radiator door (B) to allow access inside cooler module.

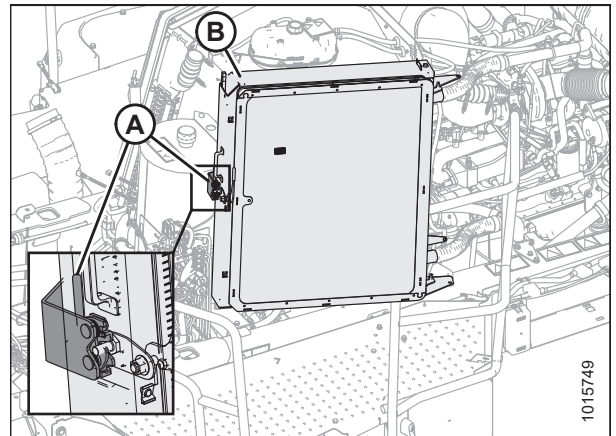

Figure 5.85: Engine Radiator Door

3. Use compressed air to clean debris from inside the cooler box (A), charge air cooler (B), and hydraulic oil cooler (C).

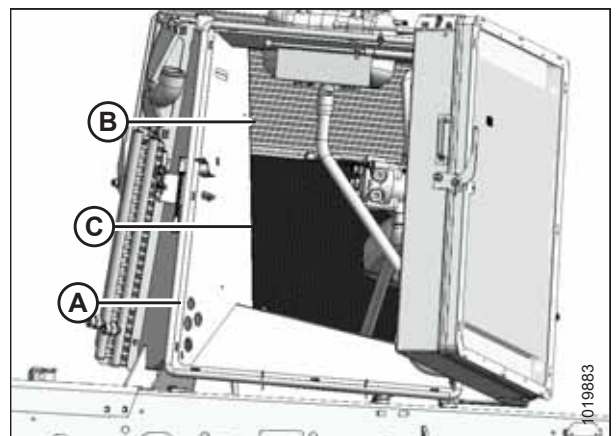

Figure 5.86: View from Inside Module – Left Side

MAINTENANCE AND SERVICING

4. At right side cooler module, with screen/case drain cooler (A) open, pull lever (B) to partially open cooler (C) away from screen.

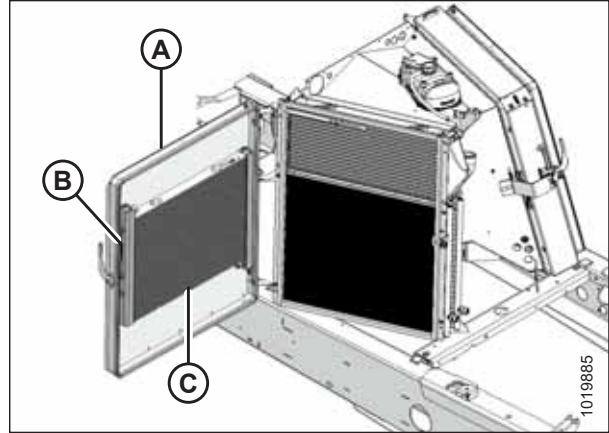

Figure 5.87: Right Cooler Module

5. Secure case drain cooler (A) with bracket (B).
6. Clean debris from case drain cooler (A) and screen (C) with compressed air.

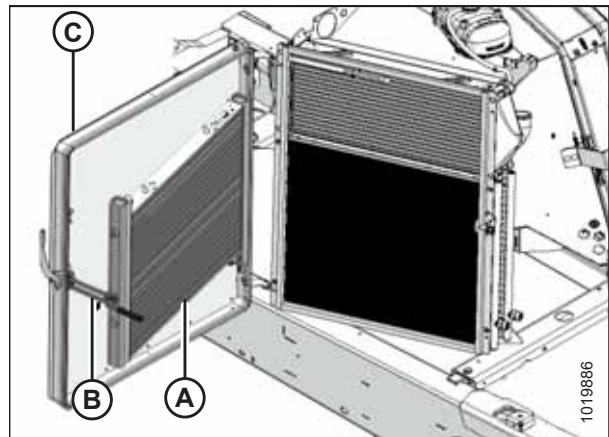

Figure 5.88: Right Cooler Module

7. Close case drain cooler (C) into screen (A) and secure with bracket (B).

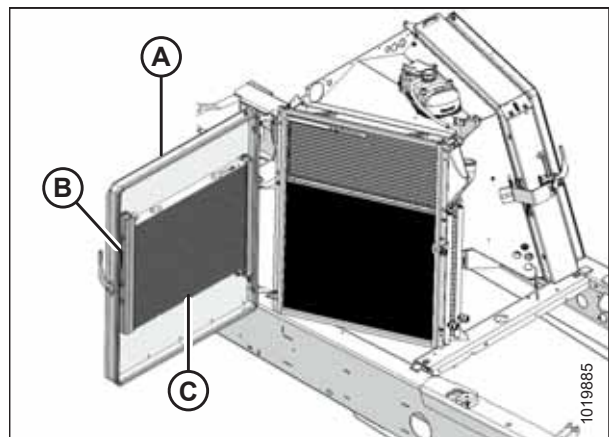

Figure 5.89: Right Cooler Module

MAINTENANCE AND SERVICING

8. Close screen/case drain cooler door (B) and secure with latch (A).

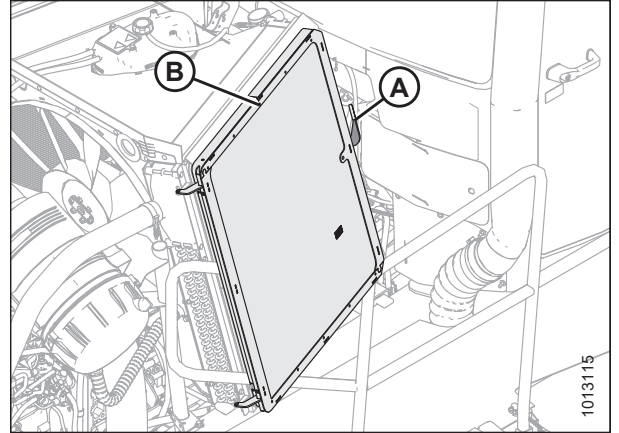

Figure 5.90: Right Cooler Module

5.10 Every 250 Hours or Annually

Complete the following maintenance tasks every 250 hours of operation or annually, whichever occurs first:

- Change engine oil and filter. For instructions, refer to [5.10.1 Changing Engine Oil, page 356](#).
- Change engine primary air filter. For instructions, refer to [5.10.2 Maintaining Engine Air Filters, page 358](#).
- Check wheel drive lubricant level. For instructions, refer to [5.10.3 Checking Wheel Drive Lubricant Level, page 363](#).
- Inspect exhaust system. For instructions, refer to [5.10.7 Inspecting Exhaust System, page 365](#).
- Change engine gearbox oil. For instructions, refer to [5.10.8 Changing Engine Gearbox Lubricant, page 367](#).

5.10.1 Changing Engine Oil

Draining Engine Oil

WARNING

To avoid bodily injury or death from unexpected startup of the machine, always stop the engine and remove the key from the ignition before leaving the operator's seat for any reason.

NOTE:

The engine should be warm prior to changing the oil.

1. Shut down the engine, and remove the key from the ignition.
2. Place a drain pan with a capacity of about 24 liters (6 U.S. gallons) under the engine oil drain.
3. Remove oil drain plug (A) and allow the oil to completely finish draining.
4. Replace drain plug (A).
5. Check the condition of the used oil. If either of the following is evident, have your Dealer correct the problem before starting the engine:
 - Thin black oil indicates fuel dilution
 - Milky discoloration indicates coolant dilution
6. Dispose of used oil properly.

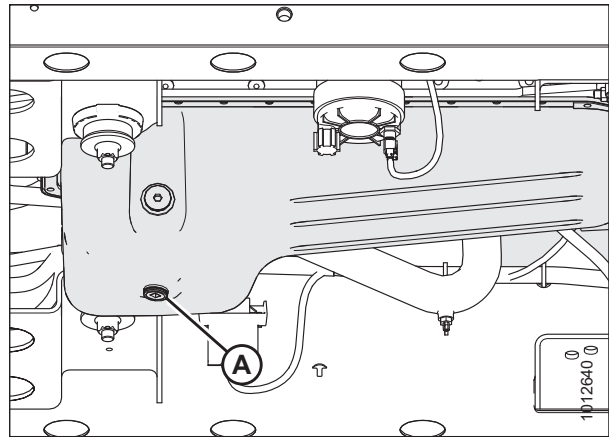

Figure 5.91: Engine Oil Drain Plug

Replacing Engine Oil Filter

NOTE:

Replace oil filter each time engine oil is changed.

1. Open the hood. For instructions, refer to [5.3.1 Opening Hood, page 302](#).
2. Place oil pan below filter.
3. Clean around filter head (A) and remove filter.

NOTE:

Check that gasket is removed from filter head.

4. Clean gasket mating surface.
5. Apply a thin film of clean oil to the gasket on the new filter. Refer to [5.1.4 Filter Part Numbers, page 297](#) for recommended oil filter.
6. Screw the new filter onto the filter mount until the gasket contacts the filter head.
7. Tighten the filter an additional 1/2 to 3/4 turn by hand.

IMPORTANT:

Do **NOT** use a filter wrench to install the oil filter. Overtightening can damage the gasket and filter.

8. Properly dispose of used oil filter.

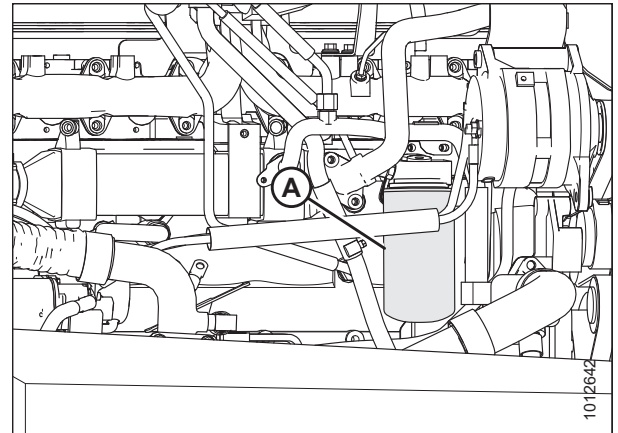

Figure 5.92: Engine Oil Filter

Adding Engine Oil

WARNING

To avoid bodily injury or death from unexpected startup of the machine, always stop the engine and remove the key from the ignition before leaving the operator's seat for any reason.

1. Open the hood. For instructions, refer to [5.3.1 Opening Hood, page 302](#).
2. Clean around filler cap (A) and remove by turning it counterclockwise.
3. Carefully pour in of new oil. A funnel is recommended to avoid spillage. Refer to the inside back cover for oil specifications.

CAUTION

Do **NOT** fill above the **HIGH** mark.

4. Replace oil filler cap (A) and turn it clockwise until snug.

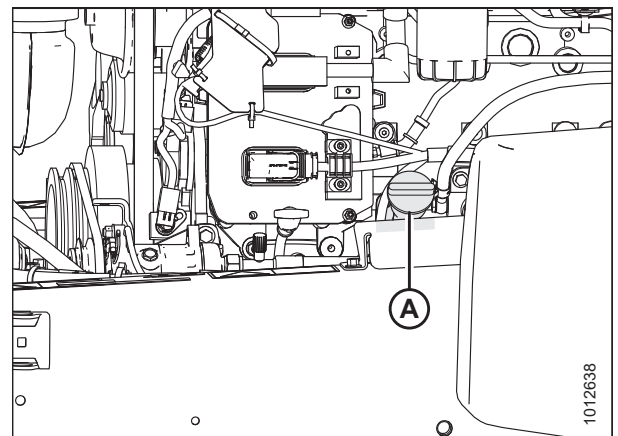

Figure 5.93: Oil Filler Cap

5. Check the oil level. For instructions, refer to [5.7.1 Checking Engine Oil Level, page 334](#).
6. Close the hood. For instructions, refer to [5.3.2 Closing Hood, page 303](#).

5.10.2 Maintaining Engine Air Filters

Removing Engine Primary Air Filter

1. Stand on right service platform.
2. Open the hood. For instructions, refer to [5.3.1 Opening Hood, page 302](#).
3. Slightly lift catch (A) at side of end cap (B). Rotate end cap counterclockwise until it stops.

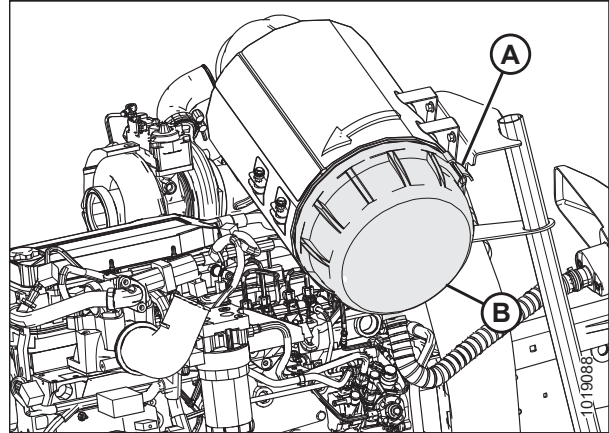

Figure 5.94: Air Filter Housing

4. Make sure arrow (A) lines up with the UNLOCK symbol on end cap.
5. Pull off the end cap.

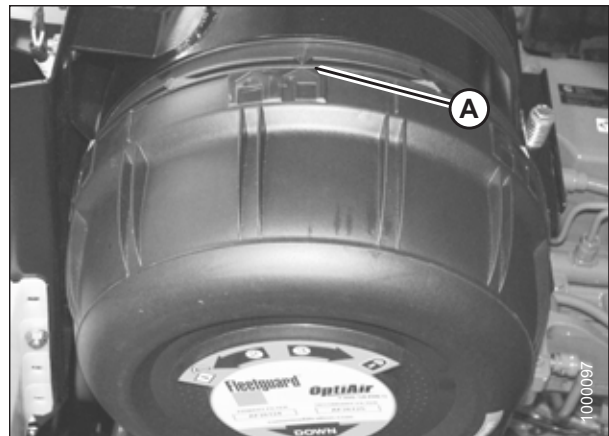

Figure 5.95: Air Filter

6. Check aspirator duct opening (A) for obstructions or damage. Clean if necessary.
7. Place cover on platform.

NOTE:

Hoses can be left connected to the cover.

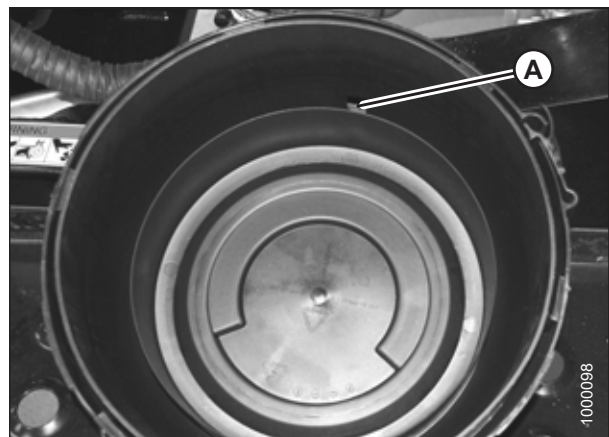

Figure 5.96: Air Filter

MAINTENANCE AND SERVICING

- Pull out primary filter element (A).

IMPORTANT:

Be extremely careful with the dirty element until it is completely out of the housing. Accidentally bumping it while still inside may cause dirt and dust to contaminate the clean side of filter housing.

- If necessary, also change secondary filter (B). For instructions, refer to [Replacing Secondary Air Filter, page 361](#).

IMPORTANT:

- Do **NOT** remove the secondary filter unless it needs replacing. It must never be cleaned.
- Replace secondary filter annually or after every third primary filter change, even if it looks clean.
- If the secondary filter looks dirty, a further inspection will be required.
- Examine filter canister for cracks and replace as necessary.
- Ensure canister retaining latches are secure.

IMPORTANT:

Clean the inside of the housing and cover carefully. Dirt left in the air cleaner housing may be harmful to your engine.

- Use a clean, water-dampened cloth to wipe every surface clean.
- Check it visually to make sure it is clean before putting in a new element.
- Always clean the gasket sealing surfaces of the housing. An improper gasket seal is one of the most common causes of engine contamination.
- Make sure that all hardened dirt ridges are completely removed wherever filter gaskets contact the cleaner housing.

Check for uneven dirt patterns on your old element. Your old element is a valuable clue to potential dust leakage or gasket sealing problems.

- A pattern on the element clean side is a sign that the old element was not firmly sealed or that a dust leak exists.
- Make certain the cause of that leak is identified and rectified before replacing the element.
- Recheck to see if the sealing surface in the housing is clean.

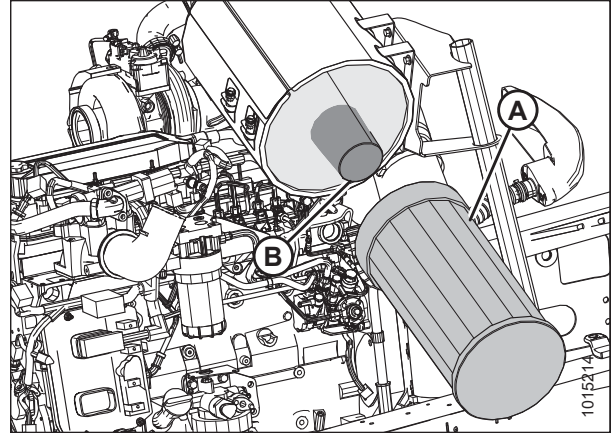

Figure 5.97: Air Filter

Installing Engine Primary Air Filter

NOTE:

For primary air filter replacement part number, refer to [5.1.4 Filter Part Numbers, page 297](#).

1. Insert new primary filter (A) into canister and push into place, ensuring that element is firmly seated in canister.

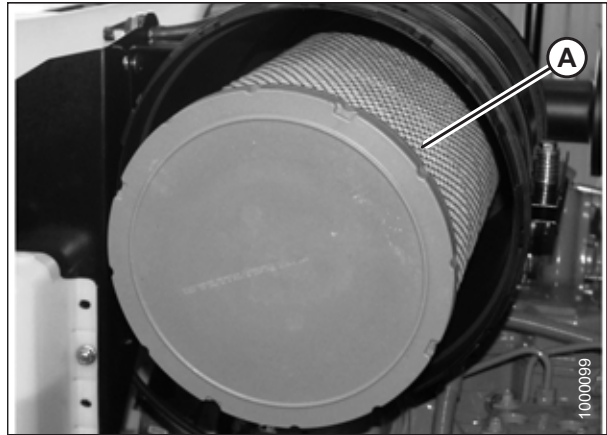

Figure 5.98: Air Filter

2. Align arrow (A) to UNLOCK position on end cap, and push end cap fully onto housing.
3. Rotate end cap clockwise until catch (A) engages housing to prevent end cap from turning.



Figure 5.99: Air Filter

4. Position end cap (B) onto filter housing with aspirator pointing approximately down.
5. Secure end cap onto filter housing by closing latch (A).
6. Close the hood. For instructions, refer to [5.3.2 Closing Hood, page 303](#).
7. Close the platform. For instructions, refer to [5.4.2 Closing Platform, page 304](#).

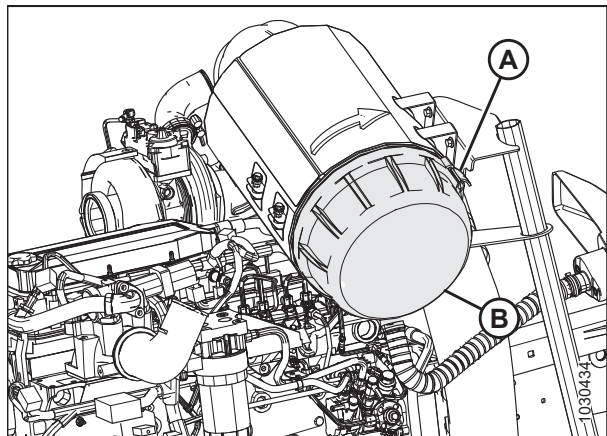

Figure 5.100: Air Filter

Cleaning Primary Air Filter

The engine air cleaner's primary filter should be replaced after three cleanings or at the specified interval. The secondary element should be replaced every third time the primary element is changed. Refer to [5.2 Windrower Break-In Inspections and Maintenance Schedule, page 298](#) for the required interval.

1. Hold a bright light inside element and check carefully for holes. Vibration would quickly wear a hole in the filter.
2. Check filter gasket for cracks, tears, or other signs of damage.
3. Check element for oil or soot contamination.
4. Check the secondary element for cleanliness. If there is visible dirt on the secondary element, replace both primary and secondary elements. Do **NOT** clean.

IMPORTANT:

- The secondary filter element should **NEVER** be cleaned, only replaced.
 - **Primary air filter element cleaning is NOT recommended due to the possible degradation of the element material.** If cleaning is performed, there are several risks involved and the following steps should be followed. If any of the conditions described in these steps are found, the filter element **MUST** be replaced.
5. If secondary element passes inspection, use compressed air not exceeding 270 kPa (40 psi) and a dry element cleaner gun to clean the primary element. Hold nozzle next to inner surface only and move up and down on pleats.

NOTE:

After three cleanings (or at the specified interval), replace the primary element.

6. Repeat inspection before installing. For instructions, refer to [Installing Engine Primary Air Filter, page 360](#).

Replacing Secondary Air Filter

IMPORTANT:

- Secondary filter element (A) should **NEVER** be cleaned, only replaced. Do **NOT** remove the secondary filter element unless it needs replacing.
 - Replace secondary element annually or after every third primary filter change, even if it appears clean.
 - If replacing secondary element, a further inspection may be necessary.
 - Examine filter canister for cracks and replace as necessary.
 - Ensure canister retaining latches are secure. Ensure filter sealing surfaces are soft, flexible and sealing, not hard and allowing debris through to secondary filter.
1. Remove the primary filter. For instructions, refer to [Removing Engine Primary Air Filter, page 358](#).

IMPORTANT:

When replacing secondary filter (A), reinsert new filter as soon as possible to prevent dirt from entering engine intake.

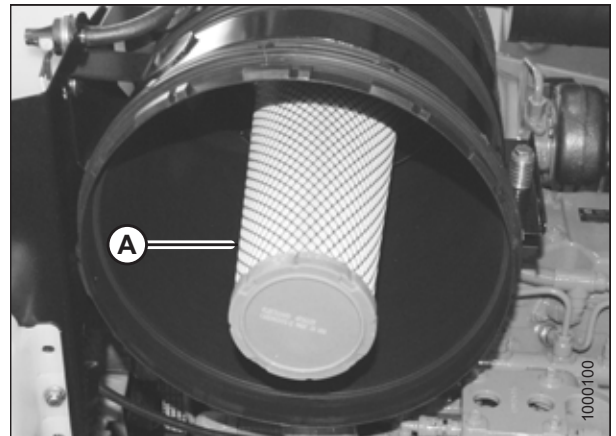

Figure 5.101: Secondary Air Filter

MAINTENANCE AND SERVICING

2. Remove secondary filter element (A) from canister.

NOTE:

If replacing filter, refer to [5.1.4 Filter Part Numbers, page 297](#).

3. Insert new secondary filter element (A) into canister, seal first, and push until seal is seated inside canister.
4. Install the primary filter. For instructions, refer to [Installing Engine Primary Air Filter, page 360](#).

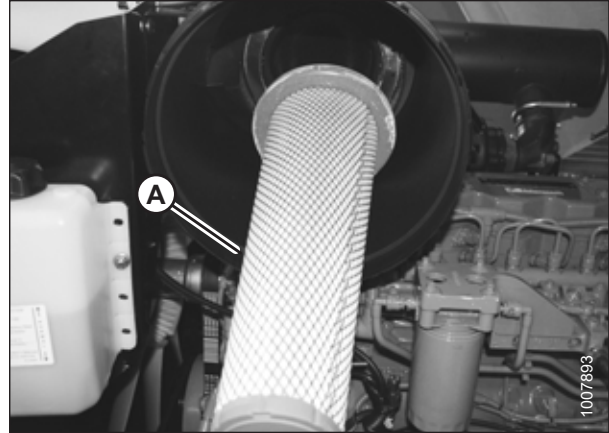

Figure 5.102: Secondary Air Filter

5.10.3 Checking Wheel Drive Lubricant Level

Check the wheel drive lubricant level every 250 hours or annually.

WARNING

To avoid bodily injury or death from unexpected startup of the machine, always stop the engine and remove the key from the ignition before leaving the operator's seat for any reason.

1. Park the windrower on level ground.
2. Position windrower so that plugs (A) and (B) are horizontally aligned with the center (C) of the hub.

WARNING

Use caution when removing plug as there may be pressure in the drive.

3. Remove plug (A) or (B). The lubricant should be visible through the port or running out slightly. If lubricant needs to be added, refer to [5.10.5 Adding Wheel Drive Lubricant – 10 Bolt](#), page 364.

NOTE:

The type of lubricant used after the first lubricant change is different from the factory supplied lubricant.

4. Reinstall plugs and tighten.

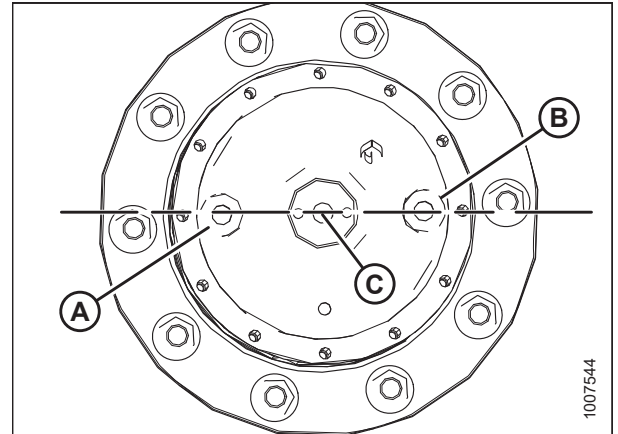

Figure 5.103: Drive Wheel

5.10.4 Checking Wheel Drive Lubricant Level – 12 Bolt (Optional)

Check the wheel drive lubricant level every 250 hours or annually.

WARNING

To avoid bodily injury or death from unexpected startup of the machine, always stop the engine and remove the key from the ignition before leaving the operator's seat for any reason.

1. Park the windrower on level ground.
2. Rotate the wheel drive until fill/drain plug (A) is vertically centered with the hub, and check plug (B) is horizontally aligned with the center of the hub.
3. Shut down the engine, and remove the key from the ignition.

WARNING

Use caution when removing plug as there may be pressure in the drive.

4. Remove check plug (B). The lubricant should be visible through the port or running out slightly. If lubricant needs to be added, refer to [5.10.6 Adding Wheel Drive Lubricant – 12 Bolt \(Optional\)](#), page 365.

NOTE:

The type of lubricant used after the first lubricant change is different from the factory supplied lubricant.

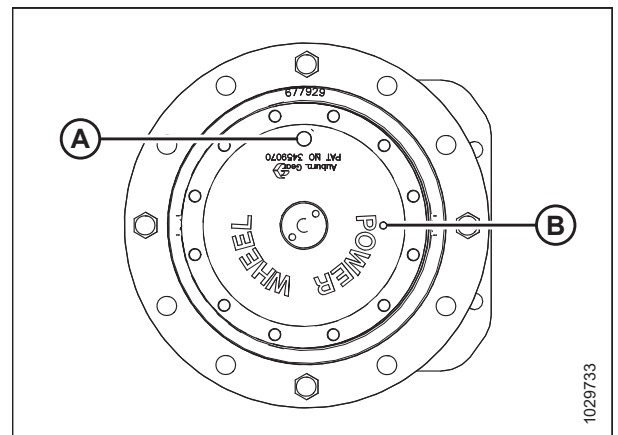

Figure 5.104: Wheel Drive – 12 Bolt

5. Reinstall check plug (B) and torque to 7.5 Nm (6 lbf·ft).
6. Reinstall fill/drain plug (A) and torque to 22 Nm (18 lbf·ft).

5.10.5 Adding Wheel Drive Lubricant – 10 Bolt

NOTE:

Do **NOT** mix lubricants of different brands or characteristics.

NOTE:

For lubricant specifications, refer to *5.1.3 Lubricants, Fluids, and System Capacities, page 295*.

WARNING

To avoid bodily injury or death from unexpected startup of the machine, always stop the engine and remove the key from the ignition before leaving the operator’s seat for any reason.

1. Rotate the wheel drive so plugs (A) and (B) are horizontally aligned with the center (C) of the hub.
2. Shut down the engine, and remove the key from the ignition.
3. Remove either plug (A) or (B).

NOTE:

PRIOR TO FIRST CHANGE: Use SAE 85W-140, API service, class GL-5, extreme pressure gear lubricant (non-synthetic).

NOTE:

AFTER FIRST CHANGE: Use SAE 75W-140 or 80W-140, API service, class GL-5, fully synthetic transmission lubricant (SAE J2360 preferred).

4. Add lubricant through one of the ports until the lubricant reaches the bottom of the ports and begins to run out.
5. Reinstall and tighten plug (A) or (B).
6. Start up and operate the windrower for a few minutes, then stop and check the oil level. Refer to the inside back cover. If necessary, add more oil.

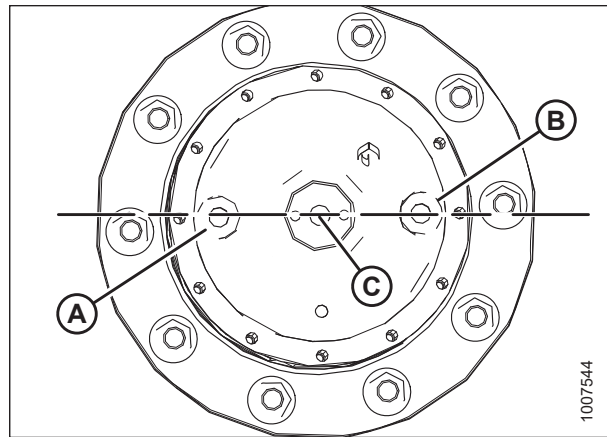

Figure 5.105: Wheel Drive

5.10.6 Adding Wheel Drive Lubricant – 12 Bolt (Optional)

NOTE:

Do **NOT** mix lubricants of different brands or characteristics.

NOTE:

For lubricant specifications, refer to *5.1.3 Lubricants, Fluids, and System Capacities, page 295*.

⚠ WARNING

To avoid bodily injury or death from unexpected startup of the machine, always stop the engine and remove the key from the ignition before leaving the operator’s seat for any reason.

1. Rotate the wheel drive until fill/drain plug (A) is vertically centered with the hub, and check plug (B) is horizontally aligned with the center of the hub.
2. Shut down the engine, and remove the key from the ignition.
3. Remove plugs (A), and (B).

NOTE:

Use SAE 85W-140, API service, class GL-5, extreme pressure gear lubricant (non-synthetic).

4. Add lubricant through port (A) until the lubricant runs out of check port (B).
5. Reinstall check plug (B) and torque to 7.5 Nm (6 lbf·ft).
6. Reinstall fill/drain plug (A) and torque to 22 Nm (18 lbf·ft).
7. Start up and operate the windrower for a few minutes, then stop and check the oil level. Refer to the inside back cover. If necessary, add more oil.

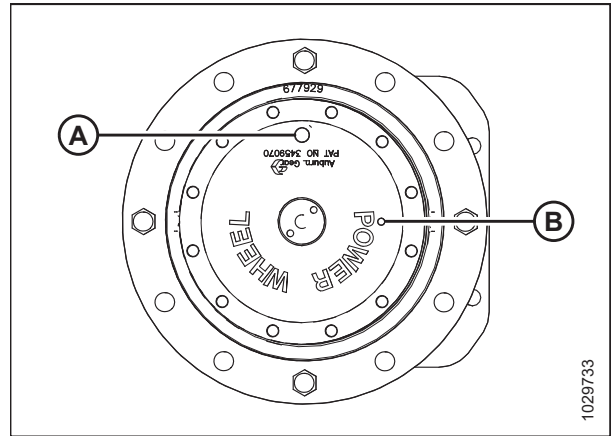

Figure 5.106: Wheel Drive —12 Bolt

5.10.7 Inspecting Exhaust System

The exhaust system consists of two main canisters for exhaust treatment. Between the two exhaust canisters is a tube with a dosing module (DM) for diesel exhaust fluid (DEF).

⚠ CAUTION

Engine exhaust stack may be hot. To avoid burns, do **NOT** touch exhaust canister when engine is running. Allow sufficient cooling time after shut-down.

The exhaust system requires no regular maintenance, but it should be inspected periodically as follows:

1. Open the hood. For instructions, refer to *5.3.1 Opening Hood, page 302*.

IMPORTANT:

Ensure the exhaust system is secure to eliminate vibration.

MAINTENANCE AND SERVICING

2. Check the following:
 - a. Exhaust canisters (A) and bellow tube (B) for dents, cracks, and wear
 - b. Straps (C) for tightness
 - c. U-bolt (D) and band clamps (E) for breakage, cracks, and rust

IMPORTANT:

Damaged exhaust piping, clamps, or components can lead to exhaust leaks and engine derate.

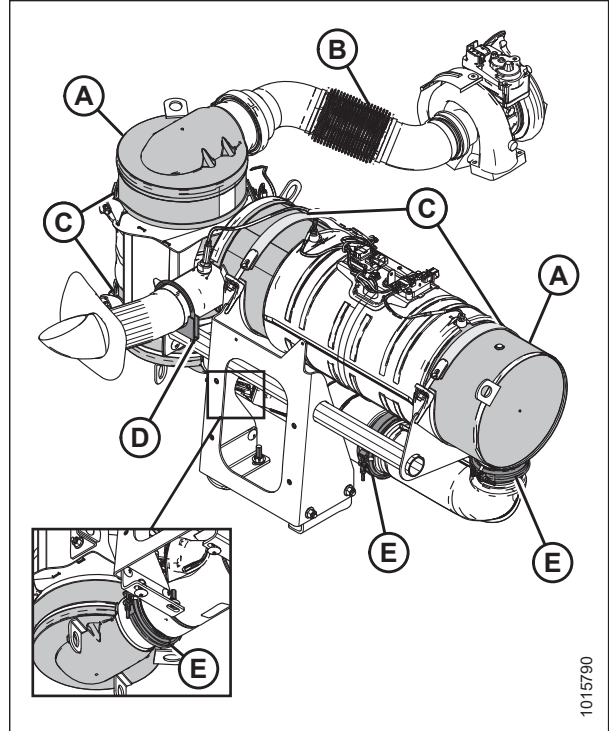

Figure 5.107: Exhaust System

3. Check the three band clamps (A) securing the tubes in between the two exhaust canisters.

IMPORTANT:

Do **NOT** change exhaust canister type, piping sizes, or exhaust configuration. Contact your Dealer for proper replacement parts.

4. Inspect the area around clamps (A) for breakage, cracks, and rust-through.

IMPORTANT:

If exhaust is leaking, tighten clamps to 12–15 Nm (9–11 lbf·ft). If leaking at band connection, replace seals. Contact your Dealer if exhaust leak persists.

5. Check tubing for dents or crushed areas.

IMPORTANT:

Dents or crushed portions of any tubing create exhaust flow restriction and increase back pressure significantly. Even relatively small dents will cause decreased fuel economy and increased turbo wear. If dents are relatively large, increased bearing and cylinder wear will occur due to increased exhaust temperature.

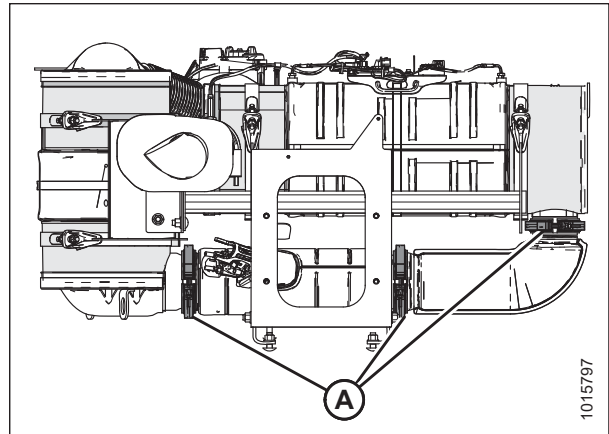

Figure 5.108: Exhaust Canister

5.10.8 Changing Engine Gearbox Lubricant

Change engine gearbox lubricant after the first 50 hours, and then at every 250 hours or annually.

WARNING

To avoid bodily injury or death from unexpected startup of the machine, always stop the engine and remove the key from the ignition before leaving the operator's seat for any reason.

CAUTION

Park on a flat, level surface with the header on the ground, the ground speed lever (GSL) in PARK position, and the steering wheel in locked position (centered). Wait for the HPT to beep and display a red P symbol to confirm the park brakes have engaged.

NOTE:

It is best to change lubricant in the morning before it warms up. If the engine is hot, wait 10 minutes before checking the lubricant level to allow the lubricant to cool and settle in the sump.

1. Park the windrower on a level surface.
2. Shut down the engine, and remove the key from the ignition.
3. Place a 4 liter (1 U.S. gallon) drain pan under the gearbox.
4. Remove drain plug (A) and allow lubricant to completely finish draining.
5. Inspect the drain plug. Small metal shavings are normal. If there are any larger metal pieces, an inspection of the gearbox will be required.
6. Install drain plug (A).

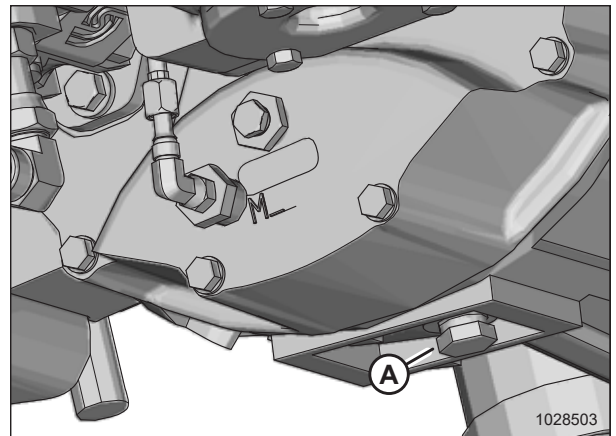

Figure 5.109: Engine Gearbox

7. Remove dipstick (A) and breather (B).

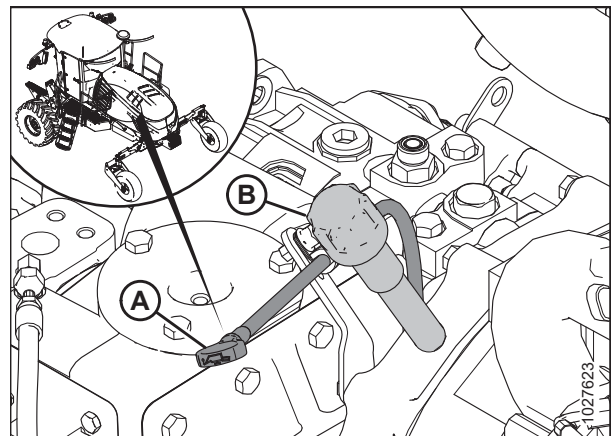

Figure 5.110: Gearbox Dipstick and Breather

MAINTENANCE AND SERVICING

8. Add lubricant until the oil level is between the ADD (A) and FULL (B) marks on the dipstick. For lubricant specifications, refer to the inside back cover.
9. Reinstall dipstick and breather.
10. Operate the engine at low idle and check for leaks at the check plug and drain plug.

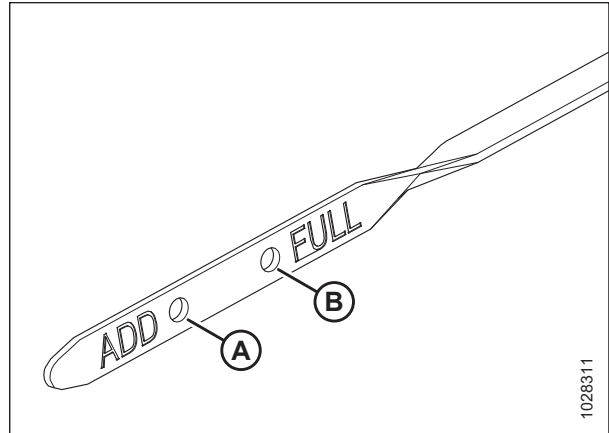

Figure 5.111: Bottom End of Dipstick

5.11 Every 500 Hours or Annually

Complete the following maintenance tasks every 500 hours of operation or annually, whichever occurs first.

- Change primary and secondary fuel filters. For instructions, refer to [5.11.1 Maintaining Fuel Filters, page 369](#).
- Change hydraulic return filter and charge filter. For instructions, refer to [5.6.9 Return Oil Filter, page 330](#) and [5.6.10 Charge Filter, page 332](#).
- Check safety systems. For instructions, refer to [5.11.2 Safety Systems, page 372](#).

5.11.1 Maintaining Fuel Filters

The windrower's fuel system is equipped with primary (A) and secondary (B) screw-on cartridge type filters. Primary filter (A) is equipped with a separator that separates sediment and water from the fuel.

NOTE:

Bottom part of image was made transparent to show primary filter (A).

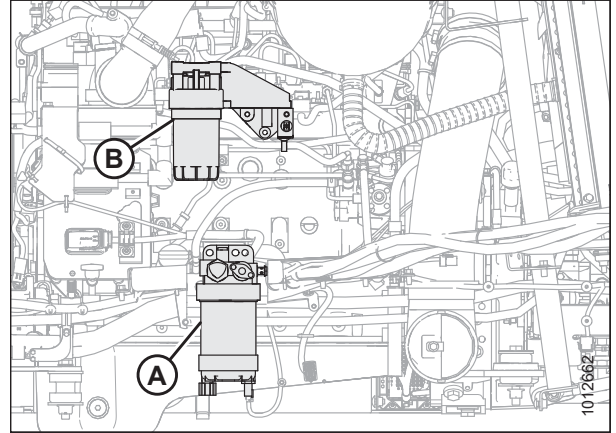

Figure 5.112: Fuel System

Removing Primary Fuel Filter

WARNING

To avoid bodily injury or death from unexpected startup of the machine, always stop the engine and remove the key from the ignition before leaving the operator's seat for any reason.

1. Shut down the engine, and remove the key from the ignition.
2. Open the hood. For instructions, refer to [5.3.1 Opening Hood, page 302](#).
3. Locate primary fuel filter (A) on the right cab-forward side of the windrower.

NOTE:

Bottom part of the image made transparent to show location of the primary filter.

4. Clean around primary filter (A) head.
5. Disconnect water in fuel (WIF) sensor (B) from bottom of filter.
6. Turn drain valve (C) by hand counterclockwise until draining occurs, and drain filter into a container.
7. Remove filter (A) with a filter wrench.
8. Clean gasket mating surface.

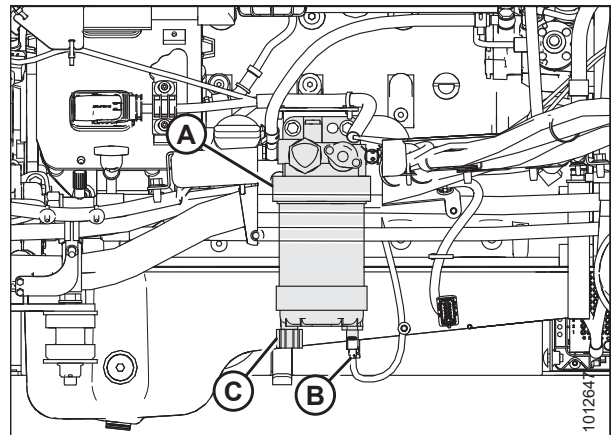

Figure 5.113: Fuel System

Installing Primary Fuel Filter

IMPORTANT:

Do **NOT** pre-fill filter with fuel. Pre-filling can contaminate the fuel system.

NOTE:

If replacing filter, refer to [5.1.4 Filter Part Numbers, page 297](#).

1. Apply some diesel fuel to the filter gasket, and screw new filter (A) onto the filter mount until the gasket contacts the filter head.
2. Reconnect water in fuel (WIF) sensor (B).
3. Tighten the filter an additional 1/2 to 3/4 turn by hand.

IMPORTANT:

Do **NOT** use a filter wrench to install the filter. Overtightening can damage the gasket and filter.

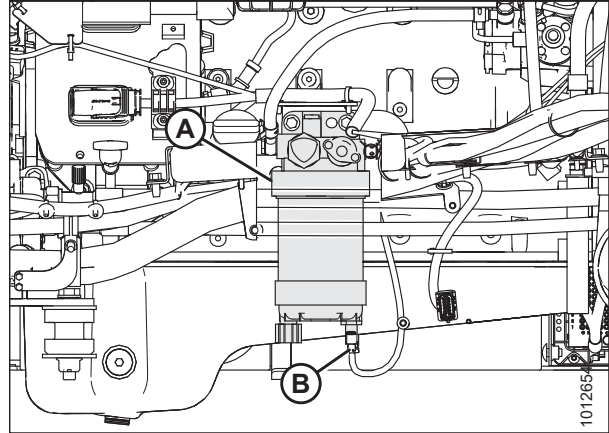

Figure 5.114: Fuel System

Removing Secondary Fuel Filter

WARNING

To avoid bodily injury or death from unexpected startup of the machine, always stop the engine and remove the key from the ignition before leaving the operator's seat for any reason.

1. Shut down the engine, and remove the key from the ignition.
2. Open the hood. For instructions, refer to [5.3.1 Opening Hood, page 302](#).
3. Clean around secondary filter head (A).
4. Place a container under the filter to catch spilled fluid.
5. Remove filter (B) with a filter wrench.
6. Clean gasket mating surface.

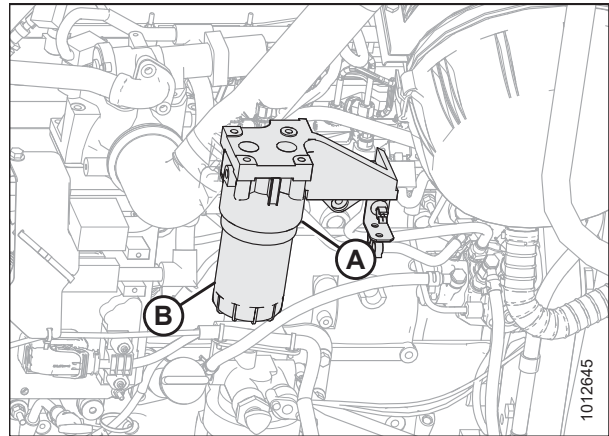

Figure 5.115: Fuel System

Installing Secondary Fuel Filter

IMPORTANT:

Do **NOT** pre-fill filter with fuel. Pre-filling can contaminate the fuel system.

NOTE:

If replacing filter, refer to [5.1.4 Filter Part Numbers, page 297](#).

1. Screw new secondary filter (A) onto the filter mount until the gasket contacts the filter head.
2. Tighten the filter an additional 1/2 to 3/4 turn by hand.

IMPORTANT:

Do **NOT** use a filter wrench to install the filter. Overtightening can damage the gasket and filter.

3. Prime the fuel system, refer to [Priming Fuel System, page 371](#).

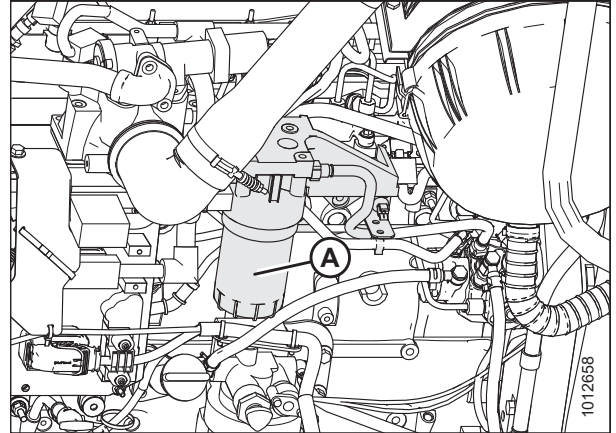

Figure 5.116: Fuel System

Priming Fuel System

Controlled venting of air is provided at the injection pump through the fuel drain manifold. Small amounts of air introduced by changing filters or injection pump supply line will be vented automatically if the fuel filters are changed in accordance with instructions.

IMPORTANT:

Do **NOT** bleed the fuel system. Manual priming will be required if:

- Fuel filter is replaced
- Injection pump is replaced
- High-pressure fuel lines are replaced
- Engine is run until fuel tank is empty



WARNING

To avoid bodily injury or death from unexpected startup of the machine, always stop the engine and remove the key from the ignition before leaving the operator's seat for any reason.



WARNING

The fuel pump high-pressure fuel lines and fuel rail contain extremely high-pressure fuel. Never loosen any fittings. Personal injury and property damage can result.

1. Shut down the engine, and remove the key from the ignition.
2. Open the hood. For instructions, refer to [5.3.1 Opening Hood, page 302](#).

MAINTENANCE AND SERVICING

3. Locate primary fuel filter assembly (A).
4. Turn priming knob (B) counterclockwise to unlock the plunger on the primary filter head.
5. Pump until hand pump becomes firm.
6. Push the plunger in and lock it by turning knob (B) clockwise until snug.
7. Try starting engine. If engine does **NOT** start, or starts then shuts down, repeat priming procedure.
8. Close the hood. For instructions, refer to [5.3.2 Closing Hood](#), page 303.

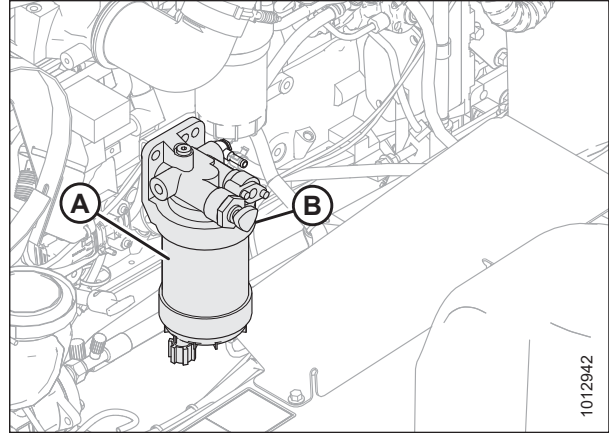

Figure 5.117: Primary Fuel Filter

5.11.2 Safety Systems

Checking Operator Presence System

The operator presence system is designed to function as described in [3.2 Operator Presence System](#), page 39.

Perform the following checks on the Operator Presence System every year or every 500 hours—whichever occurs first.

Checking the Operator Presence System switch status on the Harvest Performance Tracker (HPT) display:

1. Turn the key in the windrower ignition to the ON position.
2. Access the windrower menus by pressing soft key 5 (A).
3. Access the diagnostic menu by pressing soft key 4 (B).
4. Access the Input/Output list by pressing soft key 3 (C).

NOTE:

The screen will display two options: ABNORMAL STATUS and SYSTEM.

5. Scroll to SYSTEM and press scroll knob to select.



Figure 5.118: HPT Soft Keys

MAINTENANCE AND SERVICING

6. Scroll to INTERLOCK-NEUTRAL (A) in the Input/Output List and press scroll knob to select.

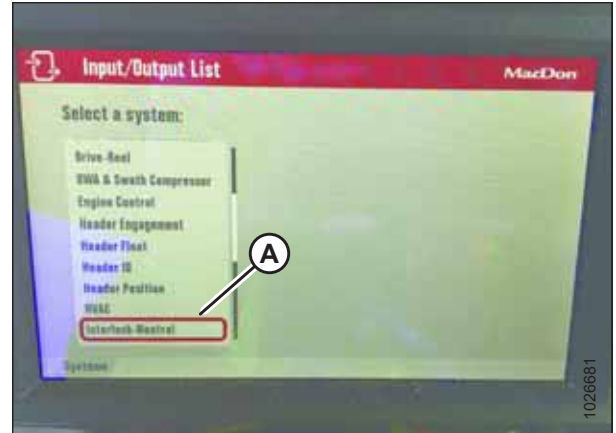

Figure 5.119: Input/Output List

7. Scroll to OPERATOR PRESENT (A) and check the following conditions:
 - The status must be ON when the Operator is sitting on the seat.
 - The status must be OFF when the Operator is not sitting on the seat.

NOTE:

If the two conditions listed above are **NOT** true, the Operator Presence System requires adjustment. Contact your MacDon Dealer.

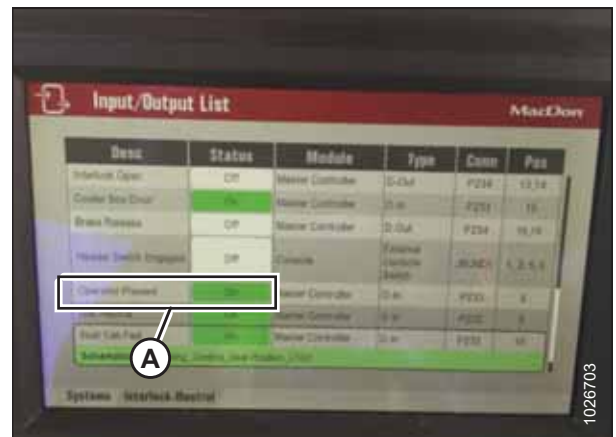

Figure 5.120: Operator Present Status (Set to ON)

Perform the following checks on the Operator Presence System every 5 years.

Checking the Operator Presence System and engine lock-out systems:

CAUTION

Park on a flat, level surface with the ground speed lever (GSL) in PARK position and the steering wheel in locked position (centered). Wait for the HPT to beep and display a red P symbol to confirm the park brakes have engaged.

WARNING

Check to be sure all bystanders have cleared the area.

1. With the windrower engine running, place the ground speed lever (GSL) in PARK and center the steering wheel until it locks.
2. With everyone clear of the machine, engage the HEADER ENGAGE switch:
 - a. After header drives are running, stand up out of the seat. In approximately 5 seconds, the header should shut off.
 - b. If **NOT**, the Operator Presence System requires adjustment. Contact your MacDon Dealer.

NOTE:

To restart the header, move the HEADER ENGAGE switch to OFF position and then back to the ON position.

3. With the windrower moving at less than 8 km/h (5 mph):

MAINTENANCE AND SERVICING

- a. Stand up out of the seat.
 - b. The Harvest Performance Tracker (HPT) display will flash NO OPERATOR DETECTED, ENGINE SHUT DOWN IN 5...4...3...2...1...accompanied by a steady tone. At 0, the engine shuts down.
 - c. If the engine does **NOT** shut down, the Operator Presence System requires adjustment. Contact your MacDon Dealer.
4. With the windrower moving at more than 8 km/h (5 mph):
 - a. Stand up out of the seat.
 - b. After a 2 second delay, the HPT will display NO OPERATOR DETECTED along with a tone.
 - c. If **NOT**, the Operator Presence System requires adjustment. Contact your MacDon Dealer.

Checking Engine Interlock

Perform the following checks on the engine lock-out system every year or every 500 hours—whichever occurs first.

WARNING

Check to be sure all bystanders have cleared the area.

1. With the engine shut down and HEADER ENGAGE switch (A) engaged, try to start the engine. If the engine turns over, the system requires adjustment. Contact your MacDon Dealer.
2. With the engine shut down, the steering wheel **NOT** centered, and ground speed lever (GSL) (B) in NEUTRAL (but **NOT** in PARK), try to start the engine. The Harvest Performance Tracker (HPT) will flash NOT IN NEUTRAL and CENTER STEERING WHEEL, accompanied by a short beep with each flash and the engine should **NOT** turn over. If the engine turns over, the system requires adjustment. Contact your MacDon Dealer.

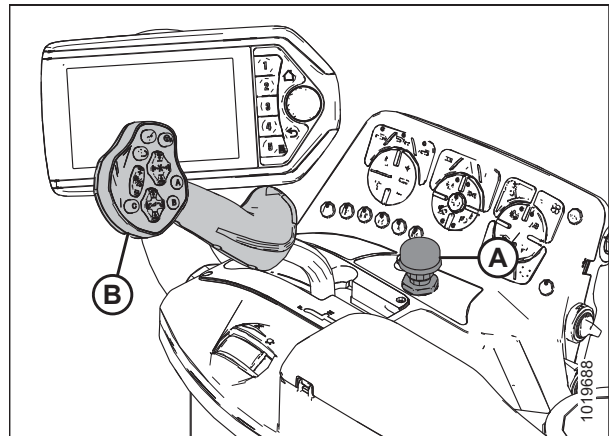

Figure 5.121: Console

A properly functioning system should operate as follows. If not, contact your MacDon Dealer.

- The starter should engage **ONLY** when the GSL is in PARK, the steering wheel is locked in the CENTER position, and the HEADER ENGAGE switch is in the OFF position.
- Under the above conditions, the brake should engage and the machine should **NOT** move after engine start-up.
- The steering wheel should **NOT** lock with the engine running and the GSL out of PARK.
- When the GSL is pulled straight out of PARK (**NOT** in forward or in reverse), the machine should **NOT** move with the engine running and with the steering wheel still centered.

5.12 Every 1000 Hours

Complete the following maintenance tasks every 1000 hours of operation.

- Change fuel tank vent filter. For instructions, refer to [5.12.1 Removing and Installing the Fuel Tank Vent Filter](#), page 375.
- Clean DEF supply module filter. For instructions, refer to [5.12.2 Diesel Exhaust Fluid Supply Module Filter](#), page 377.
- Change wheel drive lubricant. For instructions, refer to [5.6.7 Changing Wheel Drive Lubricant – 10 Bolt](#), page 328.

5.12.1 Removing and Installing the Fuel Tank Vent Filter

The fuel tank is vented by a hose and filter in the platform rail. Change the filter every 1000 hours or annually, whichever occurs first.

Change the filter as follows:

WARNING

To avoid bodily injury or death from unexpected startup of the machine, always stop the engine and remove the key from the ignition before leaving the operator's seat for any reason.

WARNING

To avoid personal injury or death from explosion or fire, do NOT smoke or allow flame or sparks near windrower when servicing.

1. Shut down the engine, and remove the key from the ignition.
2. Remove two bolts (A) and plate (B) on the right service platform.

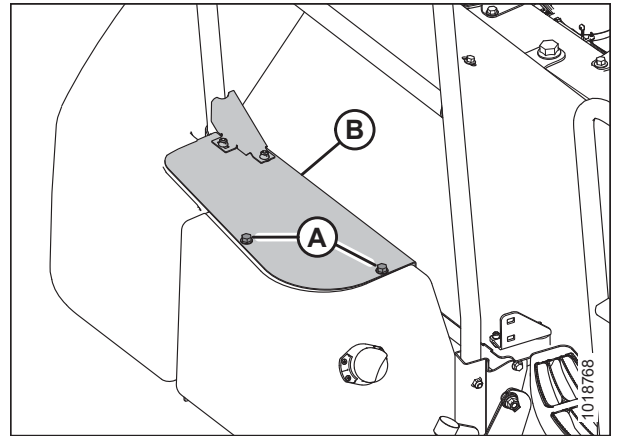

Figure 5.122: Right Service Platform

MAINTENANCE AND SERVICING

3. Release hose tension clamps (A) and slide away from filter (B).
4. Pull hoses off filter (B) and remove filter.

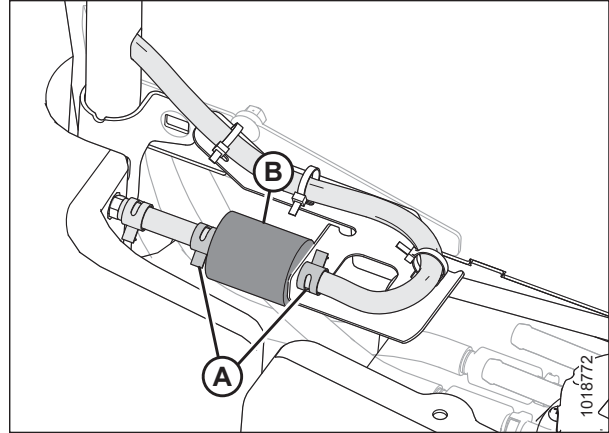

Figure 5.123: Fuel Tank Vent and Filter

5. Position new filter (A) and attach to fuel tank hose (B). The IN marking on the filter should face away from the fuel tank hose.

NOTE:

If filter has an arrow instead of an IN marking, arrow should point toward the fuel tank hose.

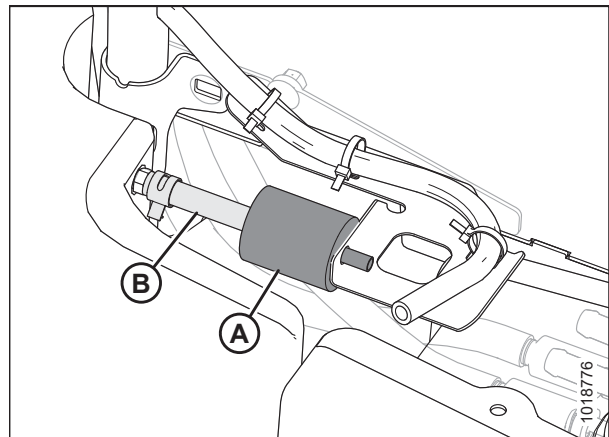

Figure 5.124: Fuel Tank Vent and Filter

6. Attach fuel vent hose (A) to filter (B) and secure both hoses with tension clamps (C).
7. Close hood. For instructions, refer to [5.3.2 Closing Hood](#), page 303.

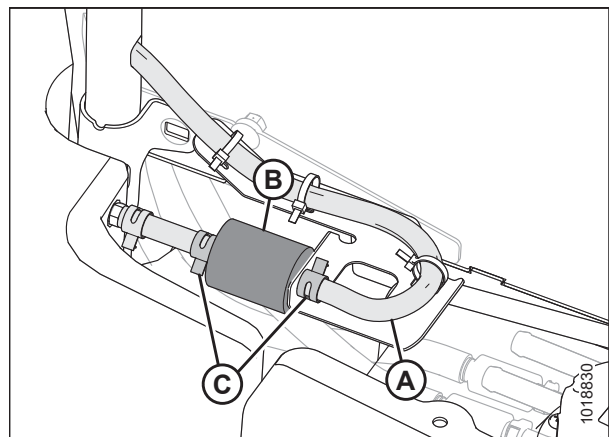

Figure 5.125: Fuel Tank Vent and Filter

5.12.2 Diesel Exhaust Fluid Supply Module Filter

The supply module filter is designed to prevent debris that may be suspended in the diesel exhaust fluid (DEF) from entering the system. Permanent damage to—and premature failure of—the DEF supply module can result from fluid debris.

Checking the DEF Supply Module Filter

1. Locate the aftertreatment diesel exhaust fluid (DEF) supply module (A) on the inside of the right platform by the engine oil dipstick.

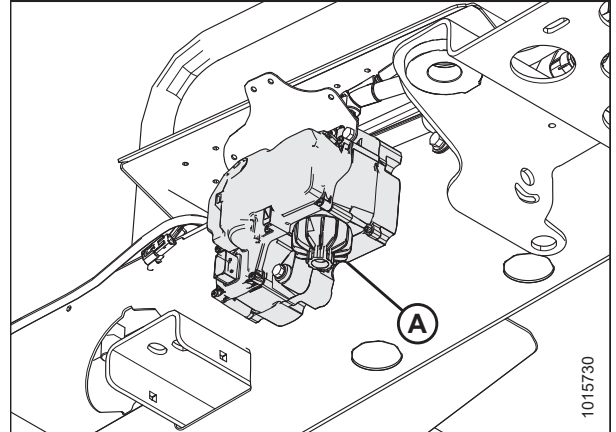

Figure 5.126: DEF Supply Module

2. Inspect the area around the seal and vent of the aftertreatment DEF supply module filter cap (A) for signs of leakage.
3. DEF fluid leaves a white deposit when dry. If there is evidence of leaking, remove the supply module filter, clean and inspect before replacing. For instructions, refer to [Cleaning and Inspecting the Supply Module Filter, page 379](#).

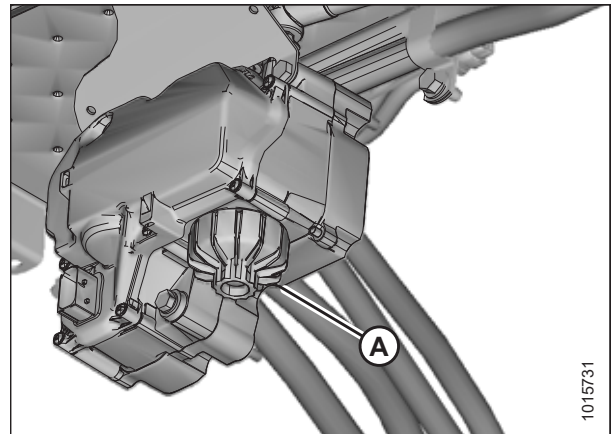

Figure 5.127: DEF Supply Module Filter Cap

Removing the Supply Module Filter

WARNING

Batteries can emit explosive gases. To reduce the possibility of personal injury, always ventilate the compartment before servicing the batteries. To reduce the possibility of arcing, remove the negative (–) battery cable first and attach the negative (–) battery cable last.

WARNING

Diesel Exhaust Fluid (DEF) contains urea. Do NOT get the substance in your eyes. In case of contact, immediately flush eyes with water for a minimum of 15 minutes. Do NOT swallow. In the event the DEF is ingested, contact doctor immediately.

WARNING

The DEF line connecting the aftertreatment DEF dosing unit to the aftertreatment DEF dosing valve is under low pressure and should **NOT** be disconnected while the engine is running or before the system has completed the purge process after engine shutdown. Disconnecting the DEF line while under low pressure could cause DEF to spray.

WARNING

Wear appropriate eye and face protection when using compressed air. Flying debris and dirt can cause personal injury.

WARNING

To avoid injury or death from unexpected start-up of machine, always stop the engine and remove the key from the ignition before leaving the operator's seat for any reason.

IMPORTANT:

Any spilled DEF must be contained and absorbed by non-combustible absorbent material like sand, and then shoveled into a suitable container for disposal. DEF is corrosive. If spilled on tank or any surface of the vehicle, rinse thoroughly with water.

IMPORTANT:

Do **NOT** disconnect the windrower batteries until the DEF dosing system has completed the purge cycle. Before beginning to remove and/or disconnect any components, wait at least 5 minutes after the ignition switch is turned OFF for the aftertreatment DEF dosing system to purge the DEF from the system. The purge cycle is an automatic process and does not require intervention to occur. The aftertreatment DEF supply module will create an audible pumping noise during the purging process.

NOTE:

DO **NOT** power wash or steam clean the filter. Use compressed air to remove any loose debris.

1. Shut down the engine, and remove the key from the ignition.
2. Wait 3 minutes for DEF system to complete purge cycle.
3. Place a catch basin under DEF filter cap to collect the remaining DEF in the filter housing.
4. Unscrew filter cap (A).
5. Remove the aftertreatment DEF filter equalizing element (B).
6. Remove the old aftertreatment DEF supply module filter element (D).

NOTE:

A disposable service tool (C) is included with the filter to aid in filter removal. Use the appropriate end of the tool to remove filter. When inserting the tool, a click sound can be heard which indicates proper engagement with the filter.

7. Discard and replace the filter and equalizing element if removed from the aftertreatment supply module.

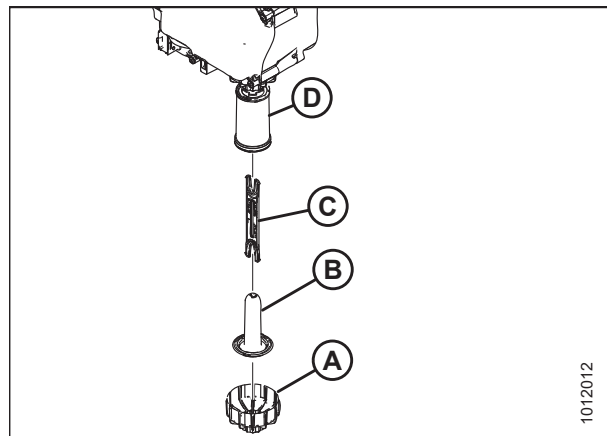

Figure 5.128: DEF Supply Module Filter

1012012

Cleaning and Inspecting the Supply Module Filter

NOTE:

If there is the possibility that contaminated diesel exhaust fluid (DEF) has gone through the DEF supply system, check the DEF filter prior to discarding the filter.

1. Check the diesel exhaust filter for evidence of contaminated DEF. Use visual and aroma characteristics of the filter to determine if contaminated fluid has passed through the dosing system.
2. Inspect the diesel exhaust filter for debris.
3. Discard the filter element and the equalizing element.
4. Inspect the aftertreatment DEF supply module filter cap for cracks or holes.
5. Check the condition of the threads on the aftertreatment DEF supply module cap.
6. If threads are damaged, replace the aftertreatment DEF supply module cap.
7. If cap threads are damaged, inspect the aftertreatment DEF supply module threads.
8. If threads of aftertreatment DEF supply module are damaged, replace the entire aftertreatment DEF supply module.
9. Clean the aftertreatment DEF supply module cap and threads on the supply module with warm water and clean cloth.

Installing the Supply Module Filter

1. Slide DEF filter equalizing element (A) into DEF filter cartridge (B).
2. Insert the assembly into aftertreatment DEF supply module (C).
3. Install cap (D) and torque to 20 Nm (15 lbf·ft).

NOTE:

The aftertreatment DEF dosing system will not prime until the correct selective catalytic reduction (SCR) catalyst temperatures are reached. To verify that there are no DEF leaks, test drive the windrower for a minimum of 15 minutes to get the SCR system up to temperature.

4. Operate the engine and check for leaks.

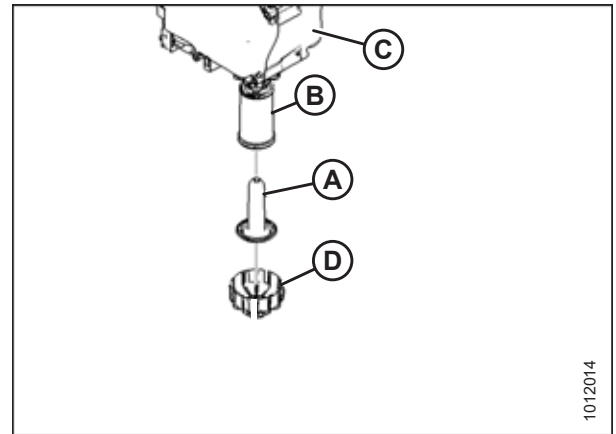

Figure 5.129: DEF Supply Module Filter

5.13 Every 2000 Hours

Complete the following maintenance tasks every 2000 hours of operation.

- Change engine coolant. For instructions, refer to [5.13.1 Changing Engine Coolant, page 380](#).
- Change hydraulic oil. For instructions, refer to [5.13.2 Draining Hydraulic Oil, page 382](#)
- Change DEF tank vent hose filter. For instructions, refer to [5.13.4 Replacing the Diesel Exhaust Fluid Vent Hose Filter, page 385](#).
- General engine inspection. For instructions, refer to [5.13.5 General Engine Inspection, page 385](#).

5.13.1 Changing Engine Coolant

Change the engine coolant after every 2000 hours of operation or two years, whichever occurs first.

Draining Coolant

WARNING

To avoid bodily injury or death from unexpected startup of the machine, always stop the engine and remove the key from the ignition before leaving the operator's seat for any reason.

CAUTION

To avoid personal injury from hot coolant, do NOT turn pressurized coolant tank cap until engine cools.

1. Shut down the engine, and remove the key from the ignition.
2. Let the engine cool.
3. Open the hood. For instructions, refer to [5.3.1 Opening Hood, page 302](#).
4. Turn pressurized coolant tank cap (A) to the first notch to relieve pressure before removing cap completely.
5. Remove the pressurized coolant tank cap.

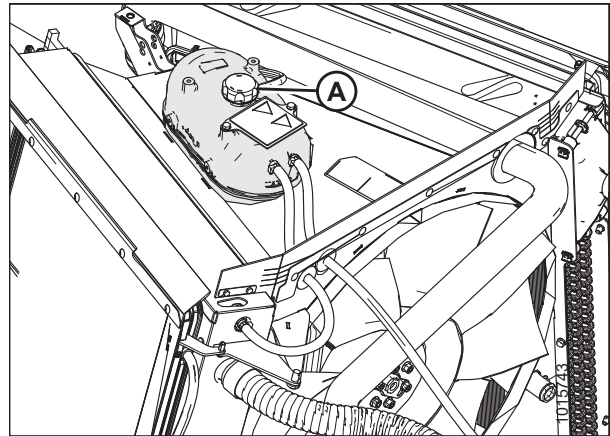

Figure 5.130: Coolant Recovery Tank

MAINTENANCE AND SERVICING

6. Locate radiator drain valve (B) on radiator inlet tube (A). It is located inside the frame beside the engine.
7. Place a drain pan (about 30 liters [8 U.S. gallons] capacity) under the drain valve, and then open radiator drain valve (B).
8. When the system has been completely drained, close radiator drain valve (B).
9. Fill system with clean water through the pressurized coolant tank. Replace the pressurized coolant tank cap.
10. Start engine and press the red area on the console TEMPERATURE CONTROL until maximum heating is reached. Run the engine until normal operating temperature (green range on display) is reached.
11. Shut down the engine, and remove the key from the ignition.
12. Drain water out before rust or sediment settles. Repeat Steps 4, page 380 to 8, page 381 to drain water.
13. Close drain valves. Fill the system with a solution of clean water and a heavy duty radiator cleaner. Follow instructions provided with the cleaner.
14. After using the cleaner solution, flush system with clean water again. Inspect radiator, hoses, and fittings for leaks.
15. Close drain valves and fill system. For instructions, refer to *Adding Coolant, page 381*.
16. Close the hood. For instructions, refer to *5.3.2 Closing Hood, page 303*.

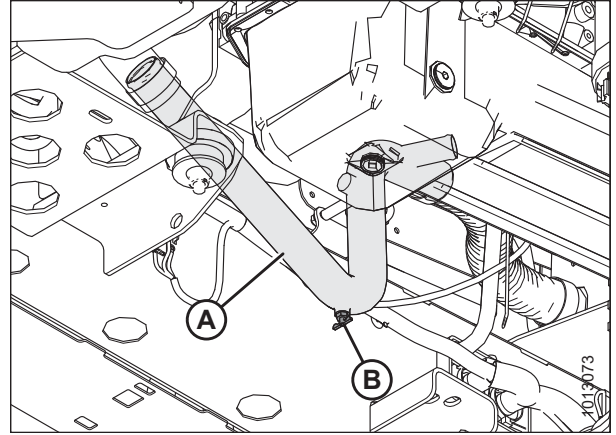

Figure 5.131: Radiator Drain Valve

Adding Coolant

Check the coolant level in the pressurized coolant tank daily, the tank should be at least one-half full. If less, add coolant.

CAUTION

To avoid personal injury from hot coolant, do NOT turn pressurized coolant tank cap until engine cools.

1. Open the hood. For instructions, refer to *5.3.1 Opening Hood, page 302*.
2. Remove pressurized cap (A) from coolant recovery tank.

NOTE:

For coolant specifications, refer to the inside back cover.

3. Add coolant at a rate not exceeding 11 L/min (3 gpm) until the recovery tank is one-half full.

NOTE:

When adding coolant, use MAX COLD line (B) on the side of tank that faces cab for an accurate measurement.

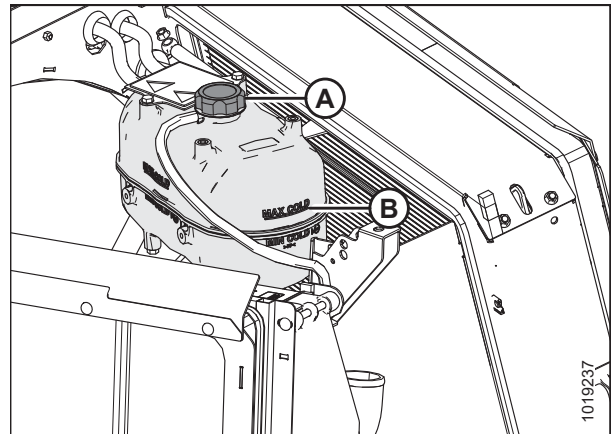

Figure 5.132: Coolant Recovery Tank

WARNING

Never start or move the machine until you are sure all bystanders have cleared the area.

4. With the pressurized cap off, start the engine and run at high idle for approximately 20 minutes or until the engine temperature reaches 85°C (185°F).
5. Add coolant until the recovery tank is one-half full. Check the coolant level again. For instructions, refer to [5.7.5 Checking Engine Coolant Level, page 341](#).
6. Replace pressurized cap (A).
7. Close the hood. For instructions, refer to [5.3.2 Closing Hood, page 303](#).

5.13.2 Draining Hydraulic Oil

Hydraulic oil should be changed every 2000 hours of operation or 3 years, whichever comes first.

WARNING

To avoid injury or death from unexpected start-up of machine, always stop the engine and remove the key from the ignition before leaving the operator's seat for any reason.

CAUTION

If machine is running, oil may be hot. Burns can result from contact with hot oil. This procedure can be performed when the oil is cold, but first run the machine to stir the oil up before draining.

1. Park the windrower on a level surface.
2. Shut down the engine, and remove the key from the ignition.
3. Open the hood. For instructions, refer to [5.3.1 Opening Hood, page 302](#).
4. Place a container (at least 65 liters [17 U.S. gallons] capacity) under drain at the bottom of the hydraulic reservoir to collect the oil.
5. On the hydraulic oil tank, turn plug handle (A) counterclockwise until loose, and then remove plug (this will allow air to enter tank).

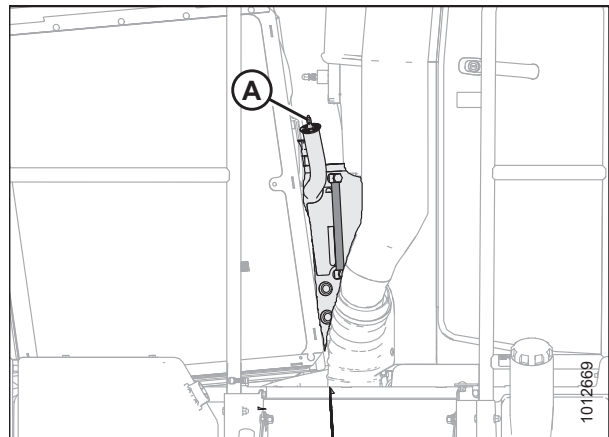

Figure 5.133: Reservoir Plug

MAINTENANCE AND SERVICING

6. From beneath the windrower, locate hose (A) that connects to inlet manifold (B).
7. Remove hose (A) from the elbow fitting and allow hose to drain into a clean container.
8. Once the tank is empty, reattach hose to elbow.

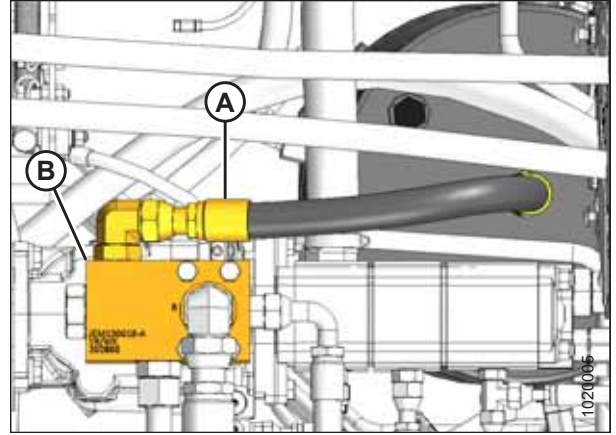

Figure 5.134: Inlet Manifold

9. Locate and remove magnetic drain plug (A) that is underneath the hydraulic oil tank.

NOTE:

Pull the traction drive hoses out of the way to allow oil to drop straight down into catch pan.

10. Inspect and clean the magnetic drain plug for any debris.
11. Reinstall drain plug. Torque plug to 75–82 Nm (55–60 lbf·ft).

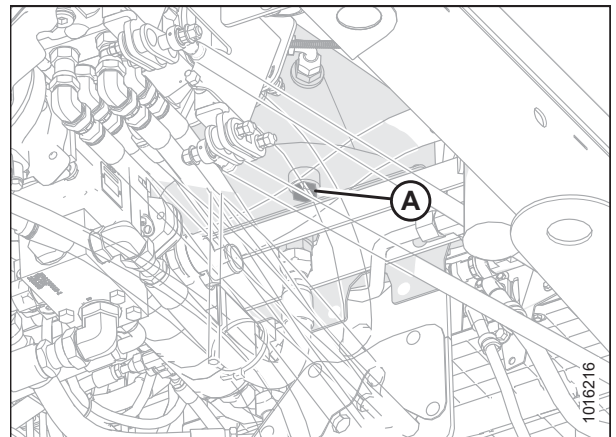

Figure 5.135: Hydraulic Oil Drain

12. Reinstall plug (A) on the hydraulic oil tank.
13. Close the hood. For instructions, refer to [5.3.2 Closing Hood, page 303](#).
14. Dispose of used oil in a manner that complies with local rules and regulations.

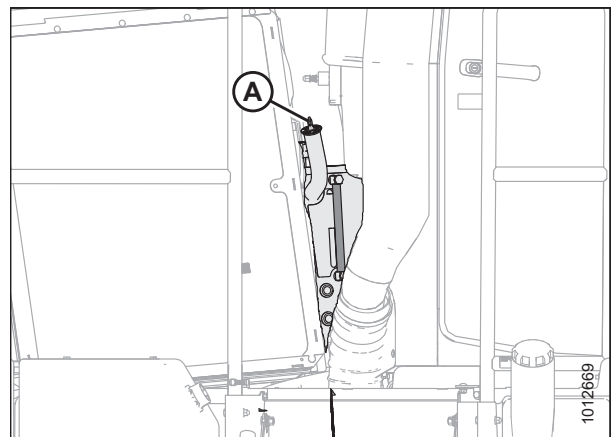

Figure 5.136: Reservoir Plug

5.13.3 Filling Hydraulic Oil

WARNING

To avoid bodily injury or death from unexpected startup of the machine, always stop the engine and remove the key from the ignition before leaving the operator's seat for any reason.

1. Park the windrower on a level surface.
2. Shut down the engine, and remove the key from the ignition.
3. Open the hood. For instructions, refer to [5.3.1 Opening Hood, page 302](#).
4. Turn plug handle (A) counterclockwise until loose and then remove plug by pulling straight out.

NOTE:

When filling oil at a fast rate, the screen element in the fill tube restricts the oil and makes it difficult for air to escape.

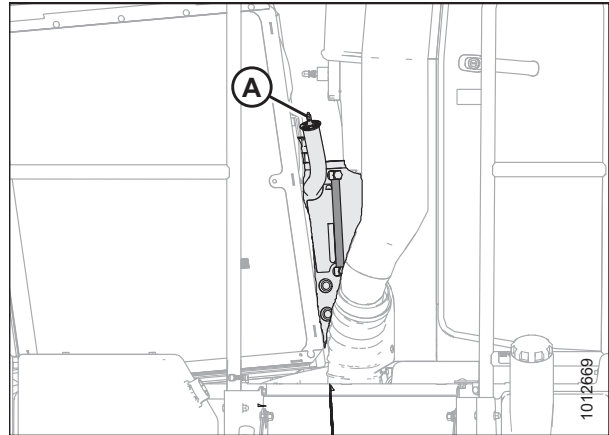

Figure 5.137: Plug Handle

5. To improve oil fill rate through the screen, open the breather cap (A) at the top of the tank to allow air to escape.

IMPORTANT:

Whenever the breather cap is opened, clean the area and take care to prevent debris from entering the tank through the opening.

6. Add oil to maintain the level between the low and full indicator marks. Refer to the inside back cover for hydraulic oil specifications and quantity.

NOTE:

When the sight glass is showing LOW, approximately 4 liters (1 U.S. gallon) is required to reach FULL.

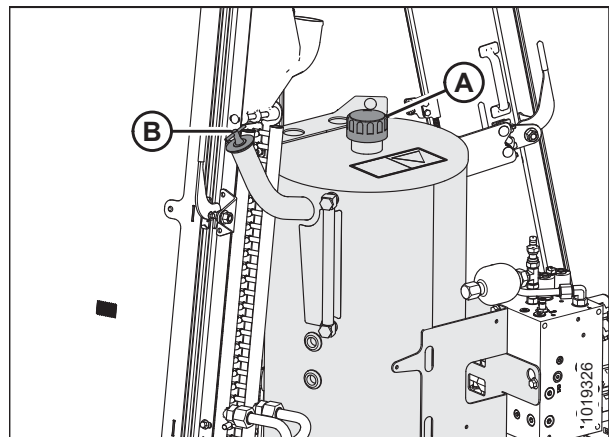

Figure 5.138: Hydraulic Oil Tank

7. Reinstall plug, and turn plug handle (B) clockwise until plug is secure.
8. Close breather cap (A).
9. Close the hood. For instructions, refer to [5.3.2 Closing Hood, page 303](#).

5.13.4 Replacing the Diesel Exhaust Fluid Vent Hose Filter

The diesel exhaust fluid (DEF) vent hose filter should be replaced every 2000 hours.

WARNING

To avoid bodily injury or death from unexpected startup of the machine, always stop the engine and remove the key from the ignition before leaving the operator's seat for any reason.

1. Shut down the engine, and remove the key from the ignition.
2. Locate vent hose filter (B) below DEF tank (A).

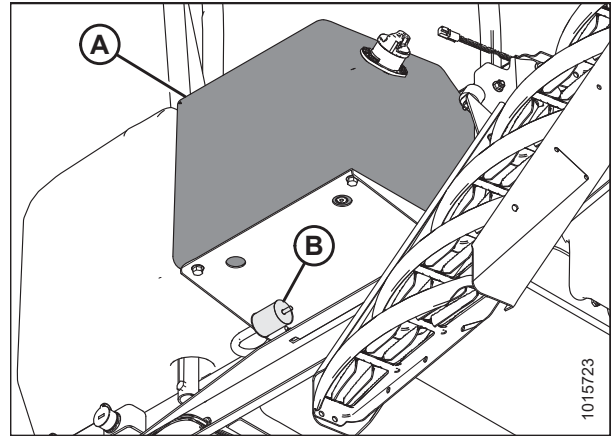

Figure 5.139: Vent Filter below DEF Tank

3. Pull vent hose filter (A) from the DEF tank vent hose.
4. Install new vent hose filter (A).

NOTE:

Ensure arrow on vent hose filter (A) points towards the DEF tank.

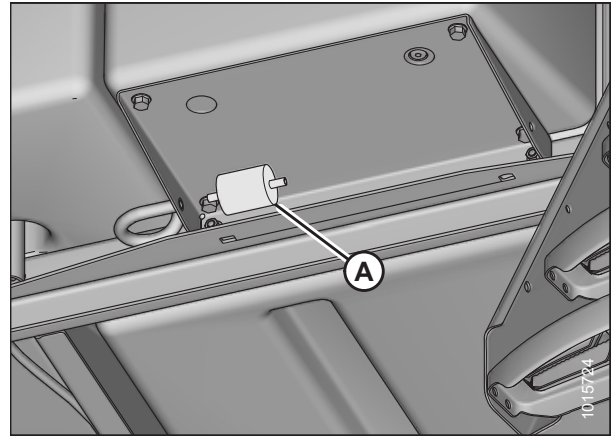

Figure 5.140: Vent Hose Filter below DEF Tank

5.13.5 General Engine Inspection

Engine inspection should be performed by your MacDon Dealer.

Refer to your engine manual for further information.

NOTE:

Owner's Manual QSB 4.5 and QSB 6.7 Engine Cummins #4021531 are supplied with your machine.

5.14 Annual Service

Complete the following maintenance tasks annually. It is recommended that annual maintenance be done prior to start of operating season.

- Check battery charge and fluid level. For instructions, refer to [5.14.1 Batteries, page 386](#).
- Check steering linkages. For instructions, refer to [5.14.2 Checking Steering Link Pivots, page 395](#).
- Check A/C blower. For instructions, refer to [5.14.3 Air Conditioning Evaporator, page 397](#).
- Check antifreeze concentration. For instructions, refer to [5.14.4 Checking Engine Coolant Strength, page 400](#).

5.14.1 Batteries

Table 5.5 Battery Specifications

Rating	Group	CCA (min)	Volt	Maximum Dimension
Heavy duty, off-road, vibration resistant	31A	760	12	334 x 188 x 232 mm (13 x 7.4 x 9.13 in.)

Maintaining a Battery



CAUTION

Do NOT attempt to service battery unless you have the proper equipment and experience to perform the job. Have it done by a qualified Dealer.

- Check battery charge **once a year**, more often if operating in cold weather. Hydrometer readings should be 1.260 to 1.300. Readings below 1.250 indicate charging is required. For instructions, refer to [Charging a Battery, page 388](#).
- Keep batteries clean by wiping with a damp cloth.
- Keep all connections clean and tight. Remove any corrosion and wash terminals with a solution of baking soda and water. A light coating of grease on terminals (after cables are attached) will reduce corrosion.
- To prolong battery life, store batteries fully charged and at -7° to +26°C (+20° to +80°F). Check voltage after storage and recharge as needed according to battery and charger manufacturer recommendations.
- Do **NOT** stack storage batteries on top of each other.
- Test batteries every 4–6 months and recharge if necessary.
- Disconnect battery ground if storing the windrower for more than 3 months.

Opening Battery Cover

⚠ WARNING

To avoid bodily injury or death from unexpected startup of the machine, always stop the engine and remove the key from the ignition before leaving the operator's seat for any reason.

1. Shut down the engine, and remove the key from the ignition.
2. Open the hood. For instructions, refer to [5.3.1 Opening Hood, page 302](#).
3. Lift up on cab end of cover (A) to disengage it from retaining tab (B), and swing cover away from the frame.

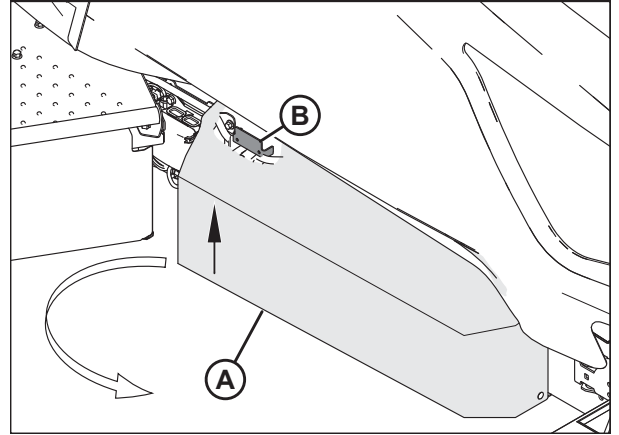

Figure 5.141: Battery Cover

Closing Battery Cover

1. Swing cover (A) towards the windrower frame. Lift up on the cab end of the cover until it is secured by retaining tab (B) on the frame.

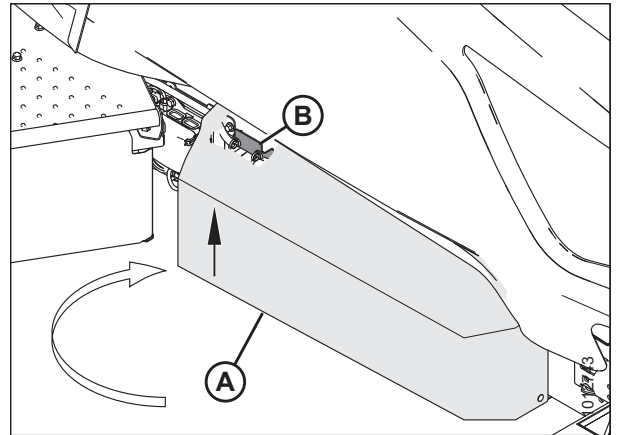

Figure 5.142: Battery Cover

Charging a Battery

CAUTION

- Ventilate the area where batteries are being charged.
- Do NOT charge a frozen battery. Warm to 16°C (60°F) before charging.
- Do NOT connect or disconnect live circuits. To prevent sparks, turn off charger and connect positive cable first. PROTECT YOUR EYES.
- If charging battery in windrower, disconnect POSITIVE battery cable before connecting charger cable, then connect ground cable last, away from battery.
- Stop or cut back charging rate if battery feels hot, or is venting electrolyte. Battery temperature must NOT exceed 52°C (125°F).
- The maximum charge rate in amperes should be NO MORE than 1/3 of the battery’s reserve capacity minute rating. If the terminal voltage exceeds 16.0 volts while charging, reduce the charge rate.
- Continue charging and reduce the rate as needed until a two-hour period results in no increase in voltage or decrease in current.

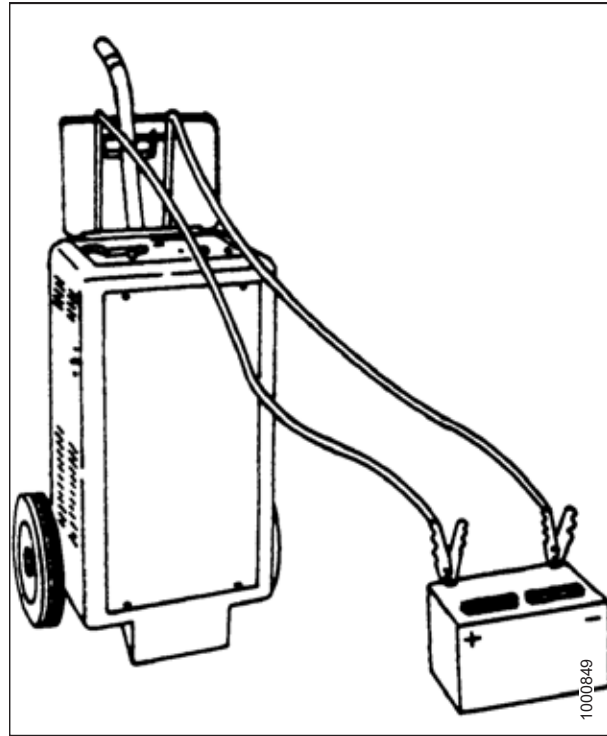

Figure 5.143: Battery Charging

Table 5.6 Voltage Chart

OCV ²²	State of Charge (%)	50 Amps	30 Amps	20 Amps	10 Amps
		Approximate battery charging time (minutes) to full charge at 27°C/80°F. ²³			
12.6	100	— Fully charged —			
12.4	75	20	35	48	90
12.2	50	45	75	95	180
12.0	25	65	115	145	280
11.8	0	85	150	195	370

WARNING

- Follow all battery manufacturers’ instructions and precautions.
- Gel and AGM (Absorbed Glass Mat) batteries require a voltage-limited charger. Charging a gel or AGM battery on a typical shop charger—even one time—may greatly shorten its life.
- If the electrolyte is accessible, verify that plates are covered before beginning to charge. At the end of charge, add distilled water as needed to bring levels to the proper height. If water is added, charge for an additional 30 minutes to mix. If electrolyte levels are low, but battery is not accessible, remove battery from service.

22. Open circuit voltage with no charging/discharging for 8 hours or more.

23. Charging time depends on battery capacity, condition, age, temperature, and efficiency of charger.

CAUTION

Follow all instructions and precautions supplied by the battery charger manufacturer, including the following:

- Charge at recommended rates and times.
- Turn off charger prior to hook up to avoid dangerous sparks. Wear proper eye protection.
- Reduce charge rate if the terminal voltage is higher than 16.0 volts while charging. The maximum charge rate in amperes should NOT exceed 1/3 of the battery's reserve capacity minute rating.
- Continue charging if there is no change in voltage or current for a two-hour period, and reduce the rate as needed.
- If the battery case gets hot during charging or spews large amount of gasses, temporarily stop charging.

IMPORTANT:

NEVER overcharge batteries. Excessive charging will shorten battery life.

WARNING

To avoid bodily injury or death from unexpected startup of the machine, always stop the engine and remove the key from the ignition before leaving the operator's seat for any reason.

1. Shut down the engine, and remove the key from the ignition.
2. Open the battery cover. For instructions, refer to *Opening Battery Cover, page 387*.
3. Remove the red plastic covers from positive cable clamps (B).
4. Remove the black plastic covers from negative terminals (A).
5. If charging battery in windrower, disconnect **positive** battery cable (C), then connect charger cable to positive post. Connect charger ground cable to the engine block last, away from battery.
6. Charge batteries in accordance with charger manufacturer's instructions.

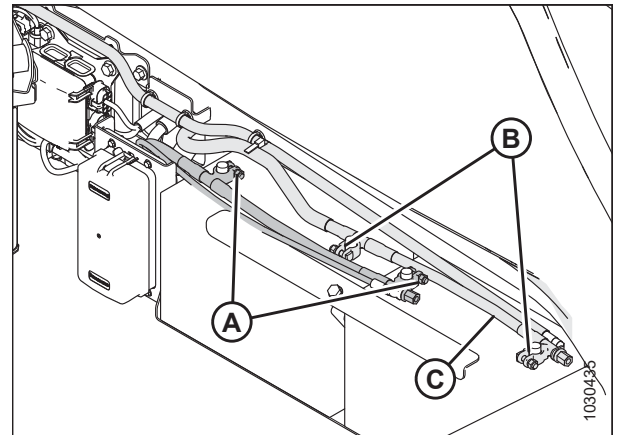

Figure 5.144: Batteries

Boosting a Battery

If boosting a battery is required, connect boost cables in the exact order described below.

WARNING

- Gas given off by batteries is explosive. Keep sparks and flames away from batteries.
- Make last connection and first disconnection at the point farthest away from the batteries.
- Wear protective eyewear when using a booster battery.
- Be sure everyone is clear of machine when starting engine. Start engine from operator's station only.

Connecting booster cables

1. To access the windrower batteries, remove the battery cover. For instructions, refer to *Opening Battery Cover*, page 387.
2. Pull back the red rubber battery terminal cover and connect one end of the positive (+) booster cable to positive (+) post (A) on the dead battery.
3. Connect the other end of the positive (+) booster cable to positive (+) post (B) on the booster battery.
4. Connect one end of the negative (-) booster cable to negative (-) post (C) on the booster battery.
5. Connect the other end of negative (-) booster cable (D) to a clean, unpainted, solid metal part on the engine of the dead unit.

WARNING

To minimize the chance of an explosion, avoid connecting the negative boosting cable to the negative post on the dead battery.

6. Turn ignition switch in cab as with normal start-up.

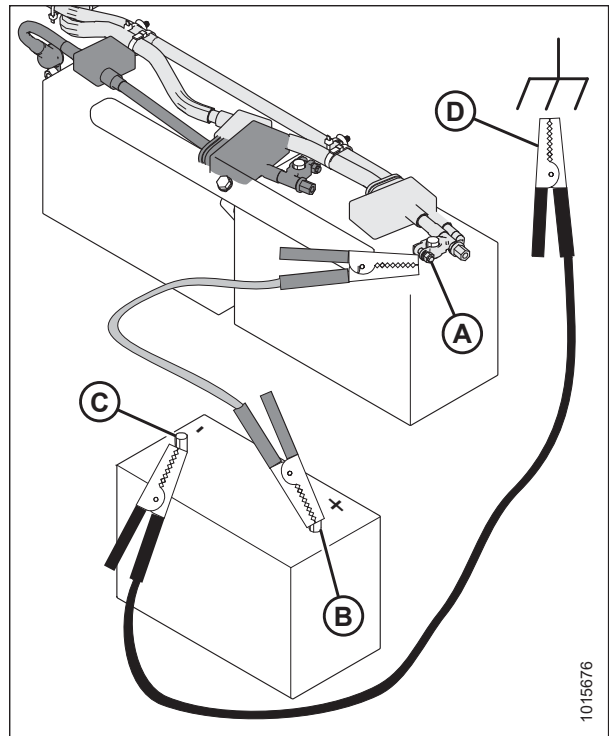

Figure 5.145: Attaching Booster Cables

Removing booster cables

CAUTION

Spark hazard. When disconnecting booster cables, do NOT allow the cable clamps to touch each other.

1. Disconnect negative (-) booster cable (A) from the engine of the unit that was boosted.
2. Disconnect the other end of the negative (-) booster cable from negative (-) battery post (B) of the booster battery.
3. Disconnect the positive (+) booster cable from positive (+) battery post (C) of the booster battery.
4. Disconnect the other end of the positive (+) booster cable from positive (+) battery post (D) of the boosted battery.
5. Replace the black and red rubber battery terminal covers.
6. Close the battery cover. For instructions, refer to [Closing Battery Cover, page 387](#).

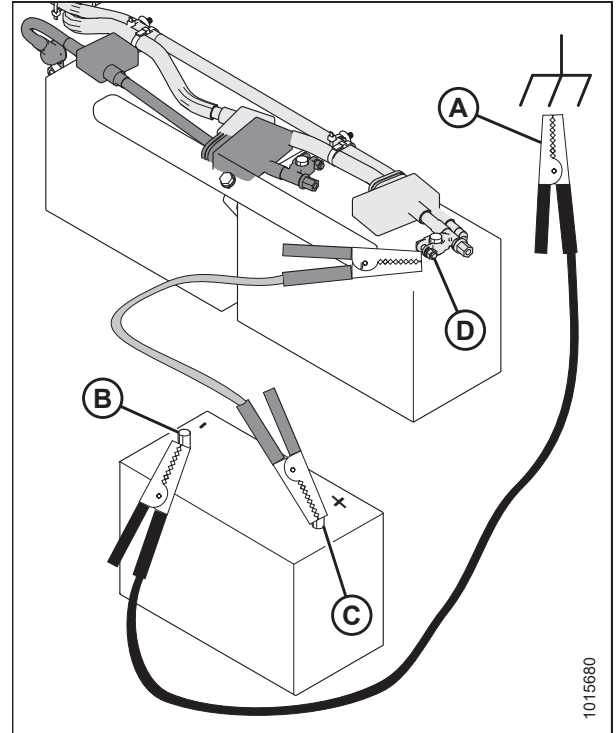

Figure 5.146: Removing Booster Cables

Removing a Battery

CAUTION

Do NOT attempt to service battery unless you have the proper equipment and experience to perform the job. Have it done by a qualified Dealer.

WARNING

To avoid bodily injury or death from unexpected startup of the machine, always stop the engine and remove the key from the ignition before leaving the operator's seat for any reason.

1. Shut down the engine, and remove the key from the ignition.
2. Open the battery cover. For instructions, refer to [Opening Battery Cover, page 387](#).
3. Disconnect the battery harness. For instructions, refer to [Disconnecting a Battery, page 393](#).

MAINTENANCE AND SERVICING

4. Loosen bolt (A) until securing strap (B) can be removed.
5. Lift batteries off the support.

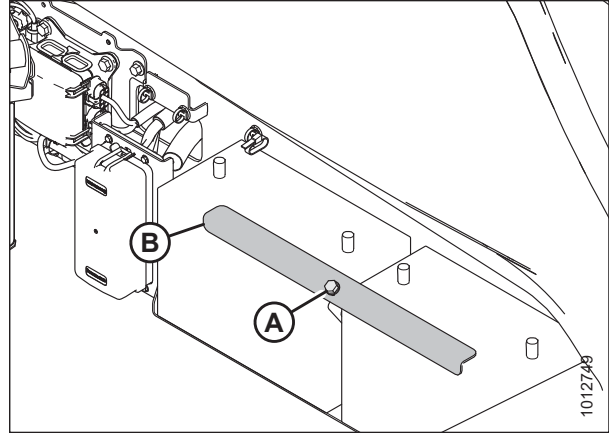

Figure 5.147: Battery Location

Installing a Battery

Table 5.7 Battery Specifications

Rating	Group	CCA (min)	Volt	Maximum Dimension
Heavy duty, off-road, vibration resistant	31A	760	12	334 x 188 x 232 mm (13 x 7.4 x 9.13 in.)

1. Position new batteries on battery support.

NOTE:

Ensure that positive terminal is positioned on the right side of the battery when facing them.

2. Install strap (B) and secure with bolt (A).
3. Connect battery cables. For instructions, refer to [Connecting Batteries, page 393](#).
4. Close battery cover. For instructions, refer to [Closing Battery Cover, page 387](#).

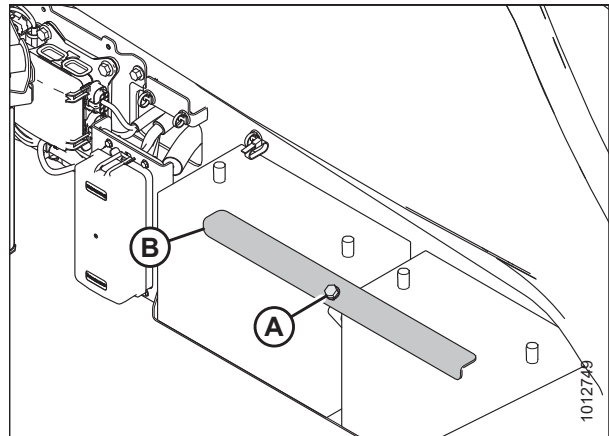

Figure 5.148: Battery Location

Disconnecting a Battery

WARNING

To avoid bodily injury or death from unexpected startup of the machine, always stop the engine and remove the key from the ignition before leaving the operator's seat for any reason.

1. Shut down the engine, and remove the key from the ignition.
2. Open the battery cover. For instructions, refer to *Opening Battery Cover, page 387*.
3. Remove the black plastic covers from negative cable clamps (A). Loosen clamps and remove cable from batteries.
4. Remove the red plastic covers from positive cable clamps (B). Loosen the clamps and remove cable from batteries.

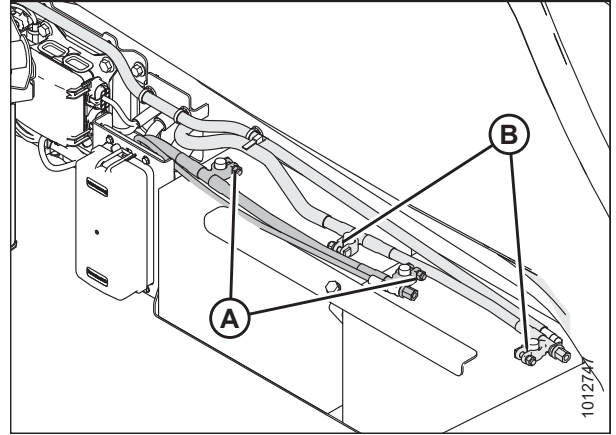

Figure 5.149: Battery Location

Connecting Batteries

WARNING

To avoid bodily injury or death from unexpected startup of the machine, always stop the engine and remove the key from the ignition before leaving the operator's seat for any reason.

1. Move latch (A) towards the right cab-forward side of the windrower.
2. Grasp louver (B), and lift the hood to open.

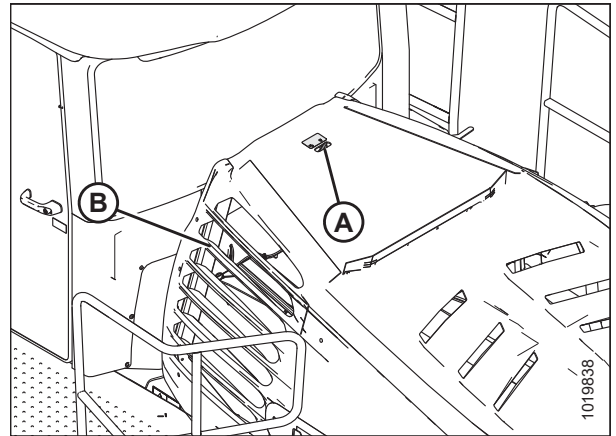

Figure 5.150: Engine Compartment Hood

MAINTENANCE AND SERVICING

- Lift up on cab-end of cover (A) to disengage it from retaining tab (B), and swing the cover away from the frame.
- If installing a new battery, remove plastic caps from battery posts.

IMPORTANT:

Batteries are negative grounded. Always connect starter cable to the positive (+) terminal of battery and battery ground cable to negative (-) terminal of battery. Reversed polarity in battery or alternator may result in permanent damage to electrical system.

NOTE:

Before connecting harness to batteries, ensure that positive terminal is positioned on the right side of battery when installed on battery support.

- Attach red positive (+) cable terminals to positive posts (B) on batteries and tighten clamps. Reposition plastic covers onto clamps.
- Attach black negative (-) cable terminals to negative posts (A) on batteries and tighten clamps. Reposition plastic covers onto clamps.

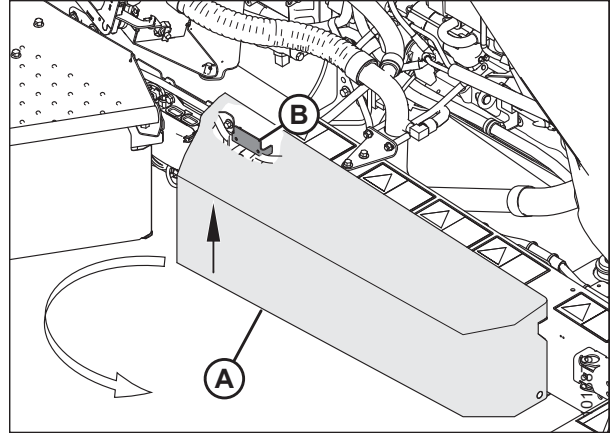

Figure 5.151: Battery Location

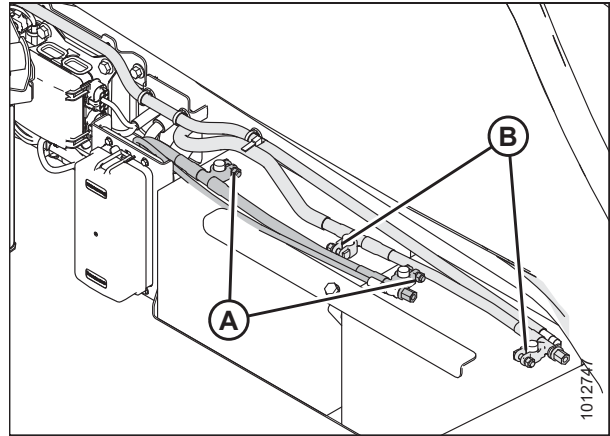

Figure 5.152: Batteries

- Swing cover (A) towards the windrower frame. Lift up on the cab end of the cover until it is secured by retaining tab (B) on the frame.
- Grasp hood by louver (C) and lower until hood engages the latch.

NOTE:

Check that the latch lever is not tilted to ensure the hood is latched.

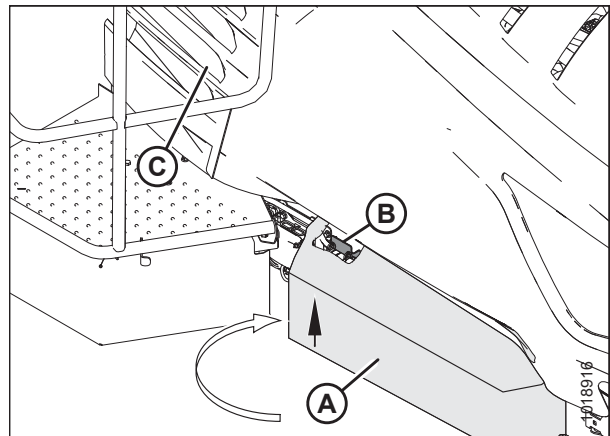

Figure 5.153: Battery Cover

Auxiliary Power Posts

The auxiliary power posts are a convenient way to connect remote auxiliary fuel pumps for in-field filling of the windrower fuel tank, trickle charging, or maintaining a battery charge.

IMPORTANT:

The auxiliary power posts are **NOT** meant for continuous duty. Remote fill pump motors have a high gallons per minute (GPM) rate, and most models can fill the windrower fuel tank within 10–15 minutes.

IMPORTANT:

The auxiliary power posts are **NOT** to be used as battery boost posts. Boosting a battery from these posts can result in blowing the auxiliary power posts' positive terminal fuse.

IMPORTANT:

Ensure the device being connected to the power posts has an amperage rating less than that of the maximum fuse rating listed on the auxiliary power posts' decal (A). 30 Amp loads and smaller are recommended as anything larger may blow the fuse if the device has a high in-rush current characteristic.

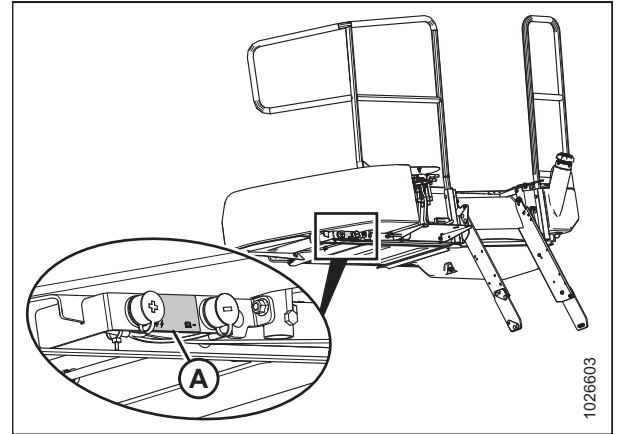

Figure 5.154: Auxiliary Power Posts Decal

5.14.2 Checking Steering Link Pivots

The following checks should be performed every year:

⚠ WARNING

To avoid bodily injury or death from unexpected startup of the machine, always stop the engine and remove the key from the ignition before leaving the operator's seat for any reason.

1. Place ground speed lever (GSL) (A) in PARK, shut down engine, and remove key.

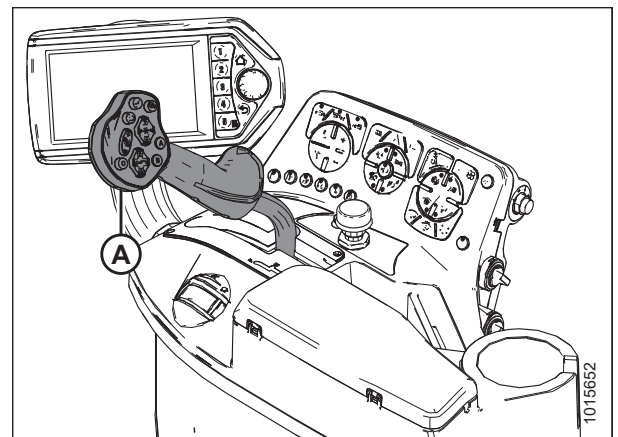

Figure 5.155: Console

MAINTENANCE AND SERVICING

2. Check steering rod bolts (A) for looseness.
3. Ensure ball joints (B) feel firm, but can be moved by hand.

NOTE:

Ball joints that are excessively loose or too stiff to pivot by hand should be replaced.

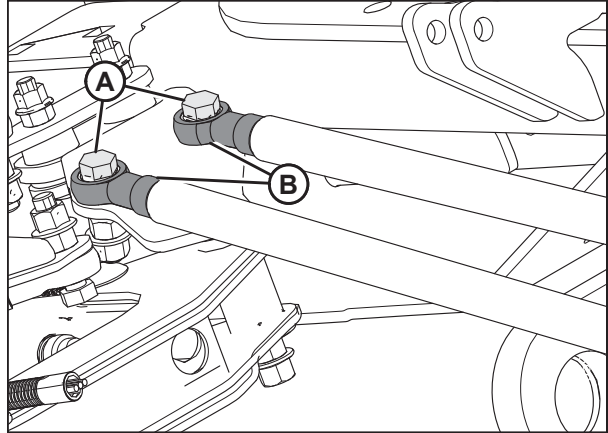

Figure 5.156: Steering Rods Beneath the Cab

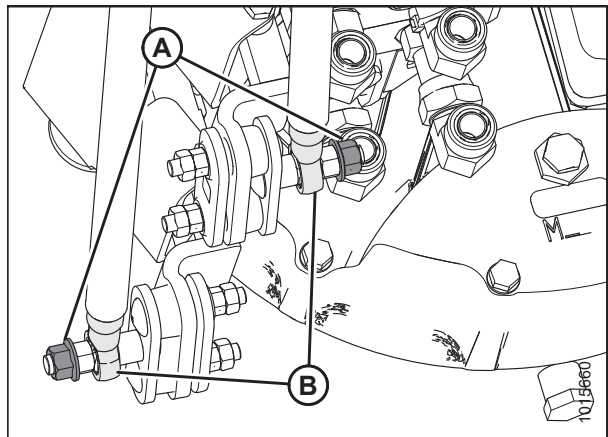

Figure 5.157: Steering Rods – Pump End

4. Check steering link bolts (A) for looseness.
5. Ensure ball joints (B) feel firm but can be moved by hand.

NOTE:

Ball joints that are excessively loose or too stiff to pivot by hand should be replaced.

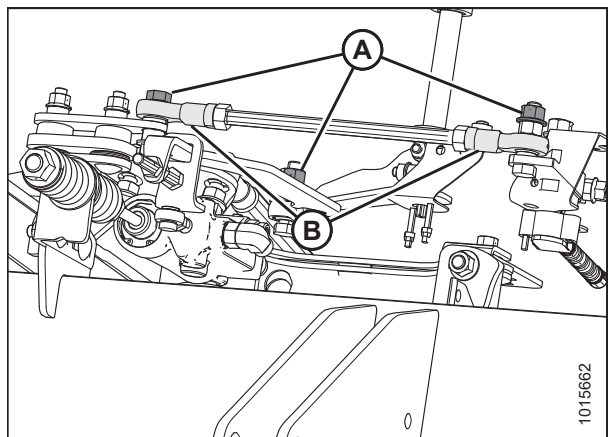

Figure 5.158: Steering Link

6. If bolts are loose:
 - a. Back off jam nut (A).
 - b. Tighten inside nut (B) to 65–72 Nm (48–53 lbf-ft).
 - c. Hold inside nut (B) and tighten jam nut (A) to 65–72 Nm (48–53 lbf-ft).
7. See your MacDon Dealer to replace any loose steering link ball joints or steering rod ball joints.
8. After replacing parts or making adjustments, perform checks for neutral interlock and steering lock. For instructions, refer to [5.11.2 Safety Systems, page 372](#).

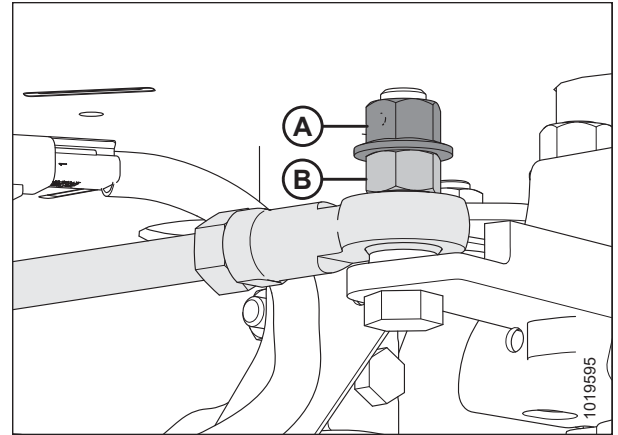

Figure 5.159: Steering Link

5.14.3 Air Conditioning Evaporator

Check the air conditioning evaporator for cleanliness every year. If the air conditioning system produces insufficient cooling, the evaporator fins may be clogged. Fins will clog up from the side opposite the blowers. The evaporator is located inside the heating air conditioning unit under the cab. To access the evaporator, remove the cover from the air conditioning unit.

Removing Air Conditioning Cover

WARNING

To avoid bodily injury or death from unexpected startup of the machine, always stop the engine and remove the key from the ignition before leaving the operator's seat for any reason.

1. Loosen clamps (A) on the two drain hoses and pull the hoses off the air conditioning (A/C) drain tubes.

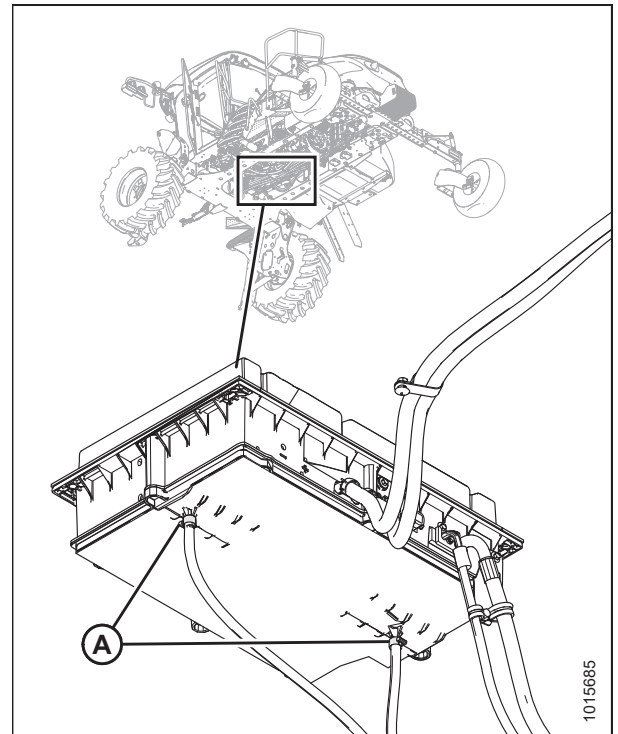

Figure 5.160: A/C Evaporator Box

MAINTENANCE AND SERVICING

2. Remove eight fasteners (A) that attach the cover to the housing. Remove cover (B).

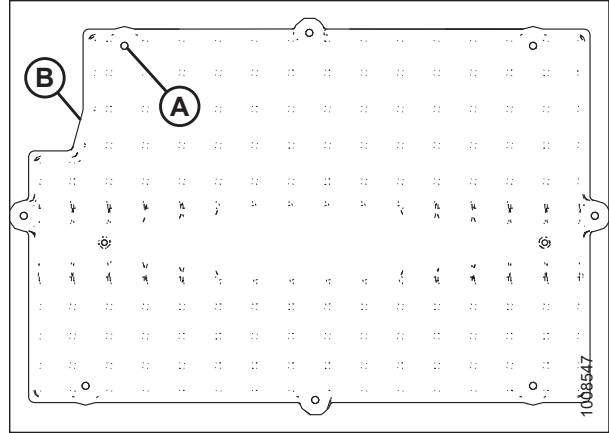

Figure 5.161: A/C Cover

Cleaning Air Conditioning Evaporator Core

WARNING

To avoid cuts from evaporator fins, do NOT use bare hands to brush away clogs.

1. Remove the air conditioning (A/C) cover. For instructions, refer to [Removing Air Conditioning Cover, page 397](#).
2. Use a vacuum cleaner or compressed air to remove dirt from inside the housing.
3. Blow compressed air through the evaporator fins from blower side (A) first as shown. Direct the air straight into the evaporator to prevent fin damage. A nozzle extension makes this procedure easier.
4. Repeat the previous step from side (B) opposite the blowers.

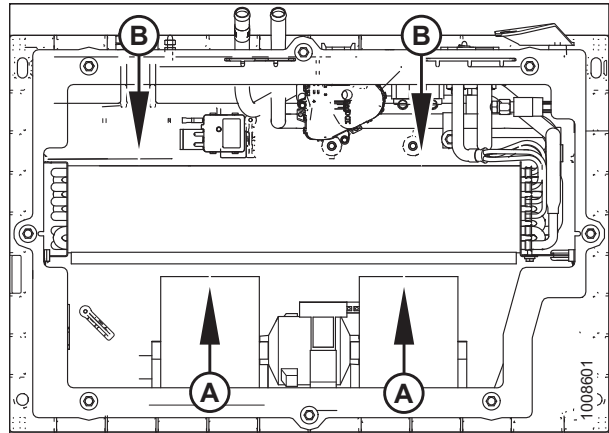

Figure 5.162: A/C Evaporator Core

5. If you can't feel the compressed air blowing through the evaporator core, proceed as follows:
 - a. Protect blower motor (A) from water.
 - b. Soak evaporator core (B) with warm water using a low pressure hose. Let soak for several minutes.
 - c. Blow compressed air through the core from blower side (C).
 - d. Repeat the soaking procedure until air blows through the evaporator freely.

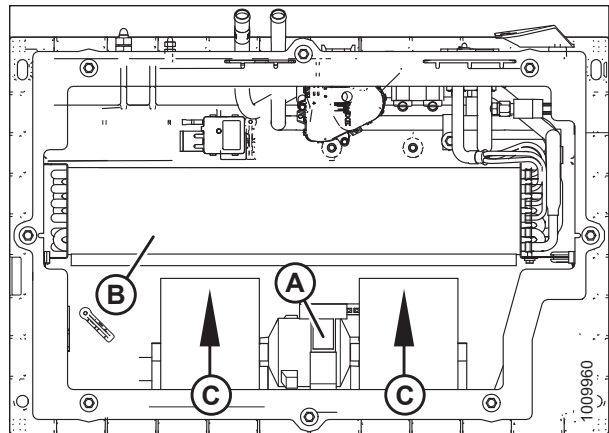

Figure 5.163: A/C Evaporator Core

Installing Air Conditioning Cover

1. Straighten any bent fins.
2. Position cover (B) and attach with eight screws (A).

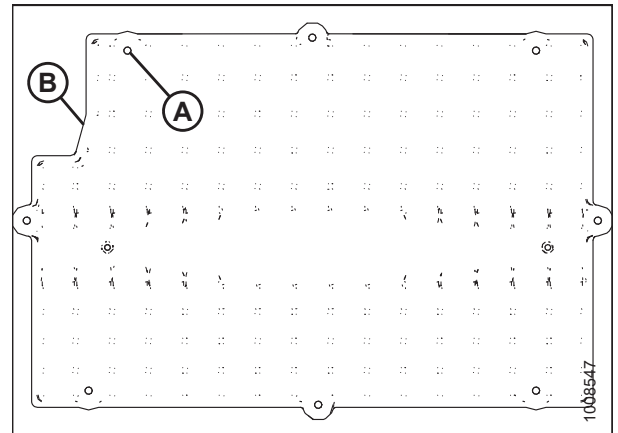

Figure 5.164: Air Conditioning Cover

3. Reattach drain hoses to drain tubes and secure with hose clamps (A). Tighten bolts to 7–7.8 Nm (40–45 lbf·in).

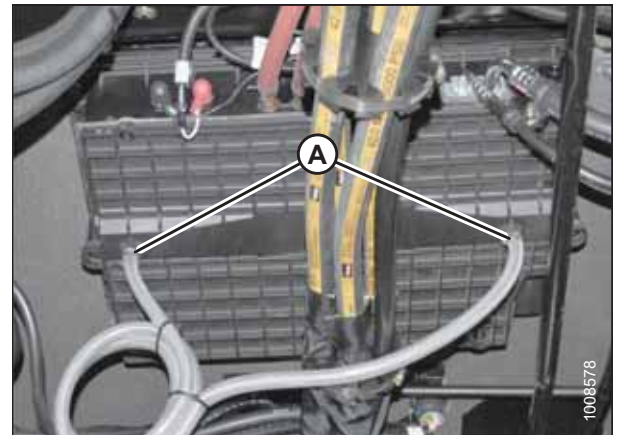

Figure 5.165: Air Conditioning Cover

5.14.4 Checking Engine Coolant Strength

Check the antifreeze in the pressurized coolant tank with a tester every year, preferably before off-season storage. Antifreeze is essential in any climate. It broadens the operating temperature range by lowering the coolant freezing point and by raising its boiling point. Antifreeze also contains rust inhibitors and other additives to prolong engine life.

CAUTION

To avoid personal injury from hot coolant, do **NOT** turn pressurized coolant tank cap until engine cools.

WARNING

To avoid bodily injury or death from unexpected startup of the machine, always stop the engine and remove the key from the ignition before leaving the operator's seat for any reason.

1. Shut down the engine, and remove the key from the ignition.
2. Open the hood. For instructions, refer to [5.3.1 Opening Hood, page 302](#).

IMPORTANT:

If antifreeze strength is not adequate, do **NOT** drain cooling system to protect against freezing. The system may not drain completely, and damage from freezing could still result.

3. Remove pressurized coolant tank cap (A).

IMPORTANT:

Turn cap (A) counterclockwise to the first notch to relieve pressure before removing cap completely.

4. Check the coolant in the pressurized coolant tank using an antifreeze tester. Tester should indicate protection to temperatures of -34°C (-30°F).
5. Inspect the pressurized coolant tank cap as follows before reinstalling:
 - a. Check the gasket for cracks or deterioration, and replace the cap if necessary.
 - b. Check that the spring in the cap moves freely. Replace the cap if spring is stuck.

6. Install pressurized coolant tank cap (A).

7. Close the hood. For instructions, refer to [5.3.2 Closing Hood, page 303](#).

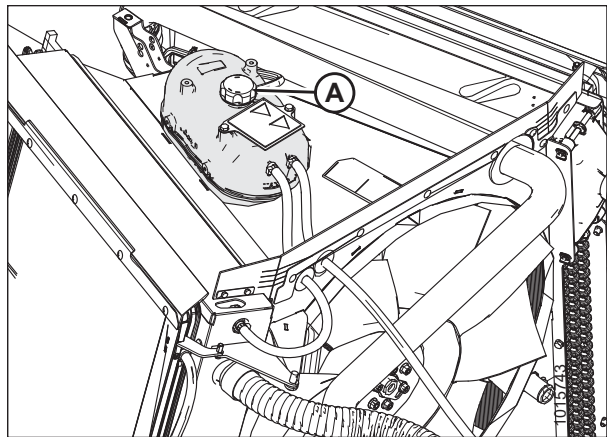

Figure 5.166: Coolant Tank

5.15 Maintenance as Required

This section details service procedures that should be done as they are required.

5.15.1 Seat Belts

- Keep sharp edges and items that can cause damage away from the belts.
- Check belts, buckles, retractors, tethers, slack take-up system, and mounting bolts for damage.
- Check that bolts are tight on the seat bracket or mounting.
- Replace all parts that have damage or wear.
- Replace belts that have cuts that can weaken the belt.
- Keep seat belts clean and dry. Clean only with a soap solution and warm water. Do **NOT** use bleach or dye on the belts, as this may weaken the material.

5.15.2 Draining Fuel Tank

Draining the fuel tank is necessary to remove old or contaminated fuel.

WARNING

To avoid bodily injury or death from unexpected startup of the machine, always stop the engine and remove the key from the ignition before leaving the operator's seat for any reason.

WARNING

- To avoid personal injury or death from explosion or fire, do **NOT** smoke or allow flame or sparks near fuel tank when refueling.
 - **NEVER** refuel the windrower when the engine is hot or running.
 - To avoid electric discharge and the risk of a fire or explosion, ensure that the fuel delivery system is properly bonded and grounded. A bonded fuel delivery system has an electrically conductive and unbroken connection between all components of the fuel delivery system (fuel supply tank, transfer pump, transfer hose, nozzle, and others). A wire connection from the fuel delivery system to the machine chassis will equalize the static electric potential between the two machines, further reducing the chance of a static electric discharge. A properly grounded fuel delivery system has an electrically conductive connection from the fuel delivery system tank to earth ground to allow static and electrical charge dissipation.
1. Shut down the engine, and remove the key from the ignition.
 2. Locate the fuel tank on the right side of the windrower frame.

3. Place a container under plug (A). The fuel tank holds 518 liters (137 gallons) total.
4. Loosen plug (A), and drain the tank.
5. Add some clean fuel to tank to flush out any remaining contaminants.

NOTE:

Do **NOT** refill the fuel tank if you need to work on the system. Refill tank when work is completed. For instructions, refer to *Filling Fuel Tank, page 115*.

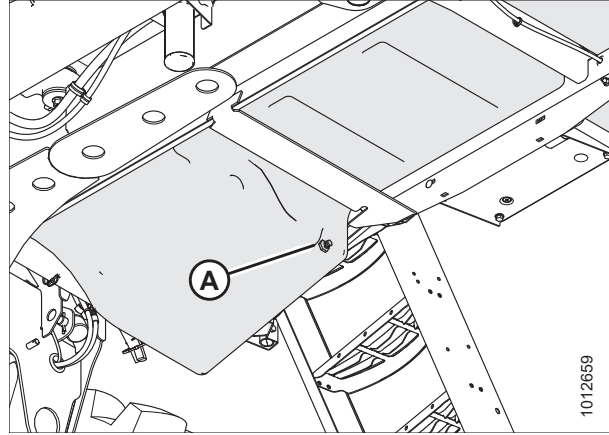

Figure 5.167: Drain Plug

5.15.3 Draining the Diesel Exhaust Fluid Tank

It is necessary to drain the diesel exhaust fluid (DEF) tank when the DEF is contaminated or if storing the windrower for a period greater than 6 months.

WARNING

To avoid bodily injury or death from unexpected startup of the machine, always stop the engine and remove the key from the ignition before leaving the operator's seat for any reason.

1. Shut down the engine, and remove the key from the ignition.
2. Place a drain pan under DEF tank (B). The drain pan should be large enough to hold 28 liters (7.5 U.S. gallons).

IMPORTANT:

Spilled DEF must be contained and absorbed by non-combustible absorbent material like sand and then shovelled into a suitable container for disposal. If spilled on tank or any surface of the vehicle, rinse thoroughly with water as DEF is corrosive.

CAUTION

Avoid contact with eyes. In case of contact, rinse immediately with water for 15 minutes.

3. Remove drain plug (A) from under tank (B) and drain.
4. Add some distilled water to tank (B) to flush out remaining contaminants.
5. Drain the distilled water that was used to clean the tank.
6. Reinstall drain plug (A) into tank (B).
7. Refill DEF tank. For instructions, refer to *Filling the Diesel Exhaust Fluid Tank, page 308*.

NOTE:

Do **NOT** refill if storing for **6 months** or longer.

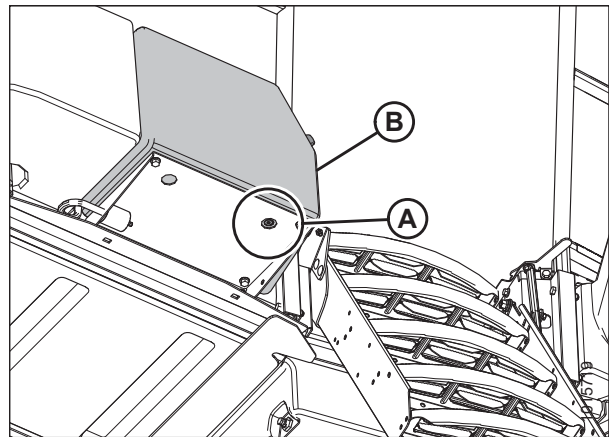

Figure 5.168: View from beneath Tank

5.15.4 Belts

Tensioning Engine Fan Drive Belt

The engine fan drive belt is automatically tightened. Manual adjustment is **NOT** required.

Replacing Engine Fan Drive Belt

WARNING

To avoid bodily injury or death from unexpected startup of the machine, always stop the engine and remove the key from the ignition before leaving the operator's seat for any reason.

1. Shut down the engine, and remove the key from the ignition.
2. Open the hood. For instructions, refer to [5.3.1 Opening Hood, page 302](#).
3. Loosen compressor mounting hardware (A) and rotate compressor (B) towards the engine to release tension on belts.
4. Remove belts (C) from compressor (B).

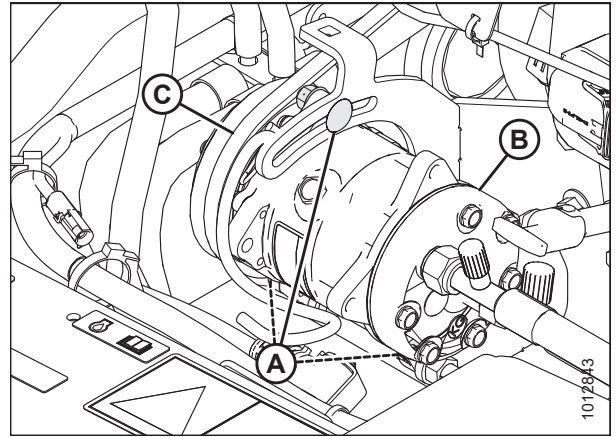

Figure 5.169: Air Conditioning (A/C) Compressor

5. Insert the drive end of a 1/2 in. drive ratchet wrench into belt tensioner (A).
6. Rotate tensioner counterclockwise until fan belt (B) can be slipped off pulley (C). Release tensioner and remove wrench.
7. Remove belt in order 1, 2, 3, as shown in [Figure 5.170, page 403](#).
8. Insert the drive end of a 1/2 in. drive ratchet wrench into belt tensioner (A).
9. Rotate tensioner counterclockwise until belt (B) can be slipped onto pulley (C). Release tensioner and remove wrench.
10. Check that belt is properly seated in all pulley grooves.

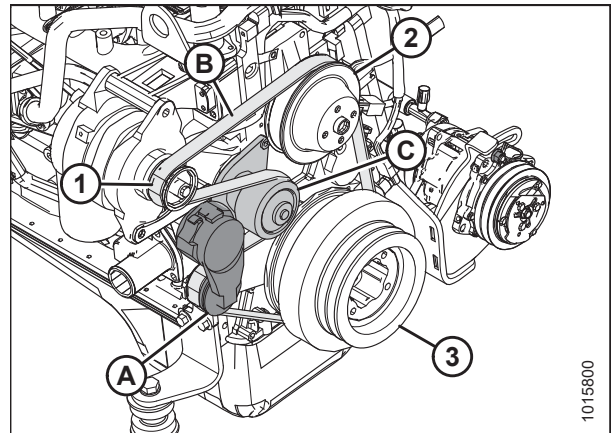

Figure 5.170: Engine Belt

MAINTENANCE AND SERVICING

11. Install compressor belts (C).
12. Pry compressor (B) away from engine so that a force of 45 N (10 lbf) deflects belts (C) 5 mm (3/16 in.) at mid-span.

NOTE:

Tab (D) on bracket can be used as support for prying.

13. Tighten compressor mounting hardware (A).
14. Recheck tension and readjust as required.
15. Close the hood. For instructions, refer to [5.3.2 Closing Hood, page 303](#).

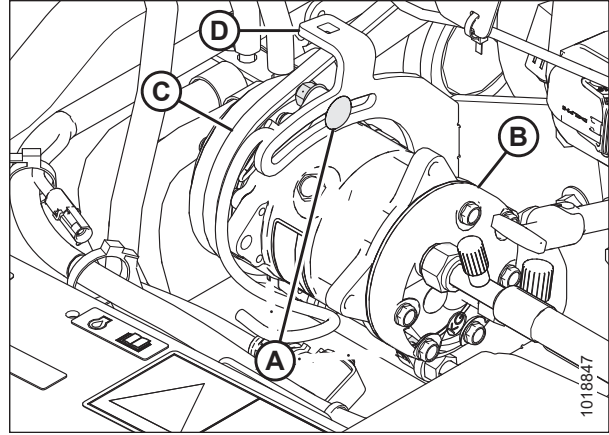

Figure 5.171: Air Conditioning (A/C) Compressor

Tensioning Air Conditioner Compressor Belts



WARNING

To avoid bodily injury or death from unexpected startup of the machine, always stop the engine and remove the key from the ignition before leaving the operator's seat for any reason.

1. Shut down the engine, and remove the key from the ignition.
2. Open the hood. For instructions, refer to [5.3.1 Opening Hood, page 302](#).
3. Loosen compressor mounting hardware (A).
4. Pry compressor (B) away from engine so that a force of 45 N (10 lbf) deflects belts (C) 5 mm (3/16 in.) at mid-span.

NOTE:

Tab (D) on bracket can be used as support for prying.

5. Tighten compressor mounting hardware (A).
6. Recheck tension and readjust as required.
7. Close the hood. For instructions, refer to [5.3.2 Closing Hood, page 303](#).

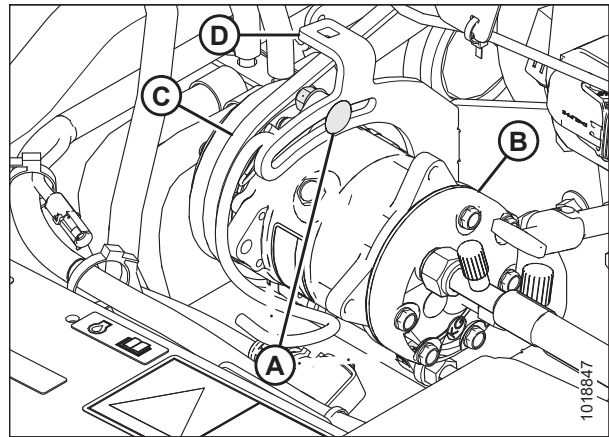

Figure 5.172: Air Conditioning (A/C) Compressor

Replacing Air Conditioner Compressor Belts

WARNING

To avoid bodily injury or death from unexpected startup of the machine, always stop the engine and remove the key from the ignition before leaving the operator's seat for any reason.

1. Shut down the engine, and remove the key from the ignition.
2. Open the platform. For instructions, refer to [5.4.1 Opening Platform, page 304](#).
3. Loosen compressor mounting hardware (A) and rotate compressor (B) towards the engine to release tension on belts.
4. Remove belts (C) from compressor (B).
5. Install compressor belts (C).
6. Pry compressor (B) away from engine so that a force of 45 N (10 lbf) deflects belts (C) 5 mm (3/16 in.) at mid-span.

NOTE:

Tab (D) on bracket can be used as support for prying.

7. Tighten compressor mounting hardware (A).
8. Recheck tension and readjust as required.
9. Close the hood. For instructions, refer to [5.3.2 Closing Hood, page 303](#).

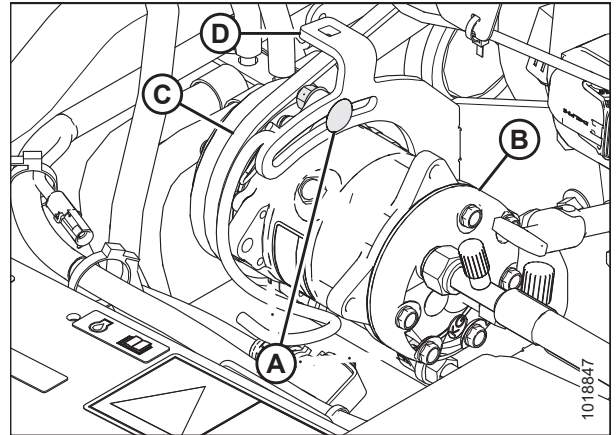

Figure 5.173: Air Conditioning (A/C) Compressor

5.15.5 Engine Speed

The maximum and idle engine speeds are factory set.

Refer to [2.2 Specifications, page 30](#) for detailed information. If specified speeds cannot be maintained, see your MacDon Dealer.

IMPORTANT:

To avoid voiding engine warranty, contact Cummins before removing components or starting repairs.

5.15.6 Lighting

Aligning Headlights – Engine-Forward

WARNING

To avoid bodily injury or death from unexpected startup of the machine, always stop the engine and remove the key from the ignition before leaving the operator's seat for any reason.

NOTE:

Header should be attached and raised to maintain proper windrower stance.

1. Position the windrower on level ground 7.5 m (25 ft.) (A) in front of a vertical surface as shown.

NOTE:

Check that casters are positioned underneath the windrower to properly align headlights.

2. Shut down the engine, and remove the key from the ignition.

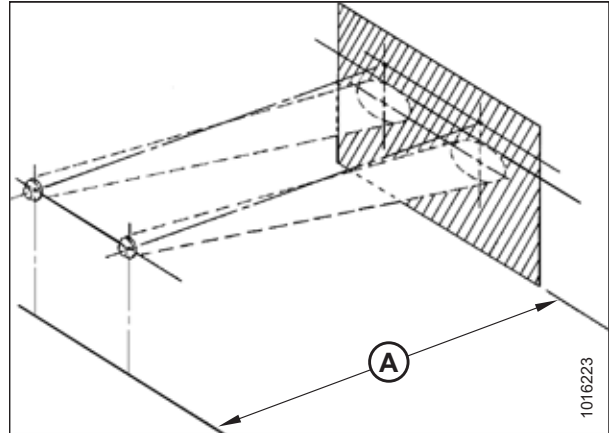

Figure 5.174: Windrower Headlight Positioning

3. Turn on ROAD lights (A) and switch to LOW BEAM.

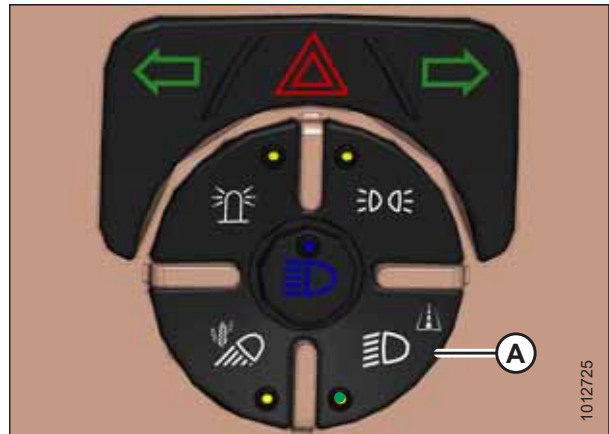

Figure 5.175: Road Light Switch

MAINTENANCE AND SERVICING

- Adjust headlight (A) with adjusting bolts (B) so that the beam's maximum height above the ground does not exceed 1263 mm (49 3/4 in.) (C). Access the bolts by reaching under the headlight bezel (D).

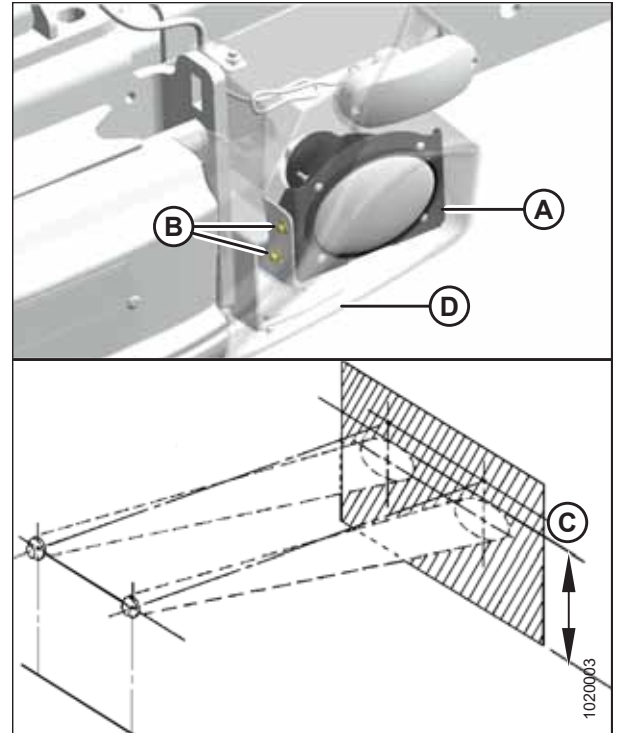

Figure 5.176: Left Engine-Forward Headlight – Right Opposite

Aligning Headlights – Cab-Forward

Adjust field lights when in the field (or equivalent) to suit Operator preference.

WARNING

To avoid bodily injury or death from unexpected startup of the machine, always stop the engine and remove the key from the ignition before leaving the operator's seat for any reason.

- Shut down the engine, and remove the key from the ignition.
- Hold onto handholds (A) on the cab front corners, and stand on header anti-slip strips.

NOTE:

Header not shown in illustration.

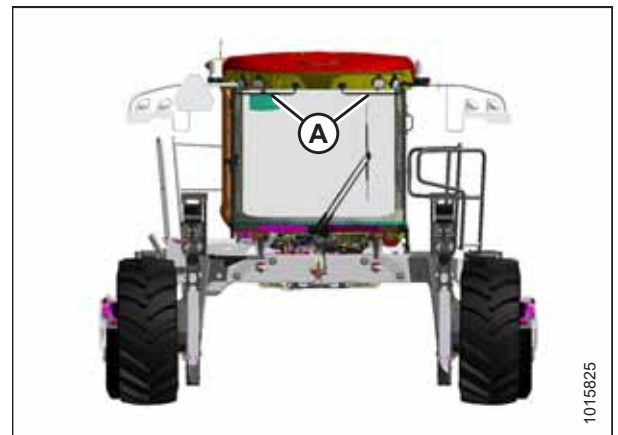

Figure 5.177: Windrower in Cab-Forward

MAINTENANCE AND SERVICING

3. Adjust lights by hand as required. Loosen/tighten nuts (A) if necessary.

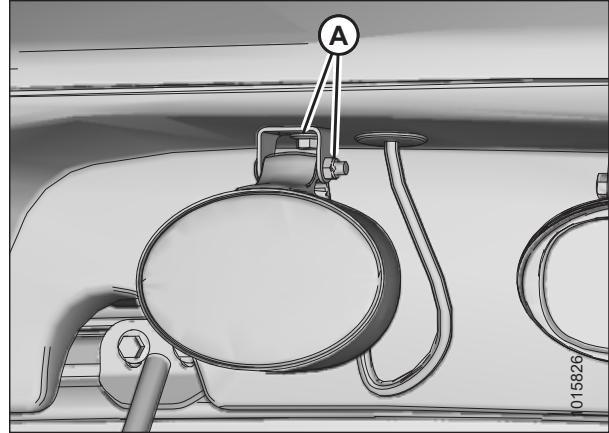

Figure 5.178: Left Cab-Forward Headlight – Right Opposite

Adjusting Front Field Lights

Adjust field lights when in the field (or equivalent) to best suit Operator preference.

WARNING

To avoid bodily injury or death from unexpected startup of the machine, always stop the engine and remove the key from the ignition before leaving the operator's seat for any reason.

1. Shut down the engine, and remove the key from the ignition.
2. Hold onto handholds (A) on the cab front corners, and stand on header anti-slip strips.

NOTE:

Header not shown in illustration.

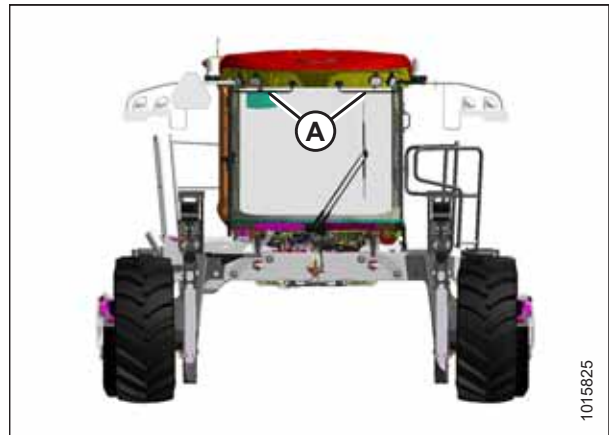

Figure 5.179: Windrower in Cab-Forward

MAINTENANCE AND SERVICING

- Adjust lights by hand as required. Loosen nuts (A) if necessary and retighten.

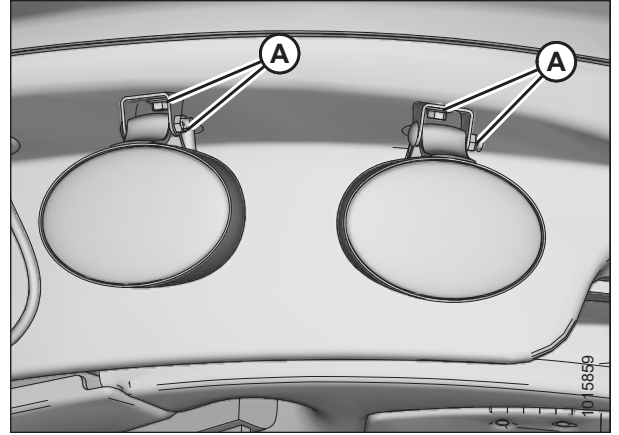

Figure 5.180: Left Cab-Forward Lights – Right Opposite

Adjusting Rear Roof Work Lights

Adjust lights to best suit Operator preference.

WARNING

To avoid bodily injury or death from unexpected startup of the machine, always stop the engine and remove the key from the ignition before leaving the operator's seat for any reason.

- Stand on left or right platform (B) to access rear roof work lights (A).

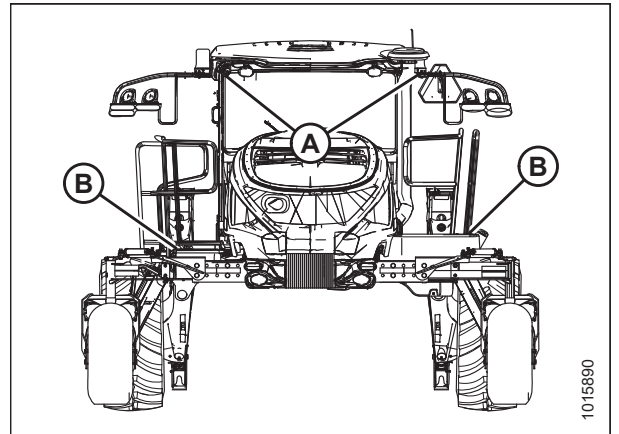

Figure 5.181: Rear Roof Work Lights

MAINTENANCE AND SERVICING

2. Adjust light by hand. Loosen or tighten bolts (A) if necessary.

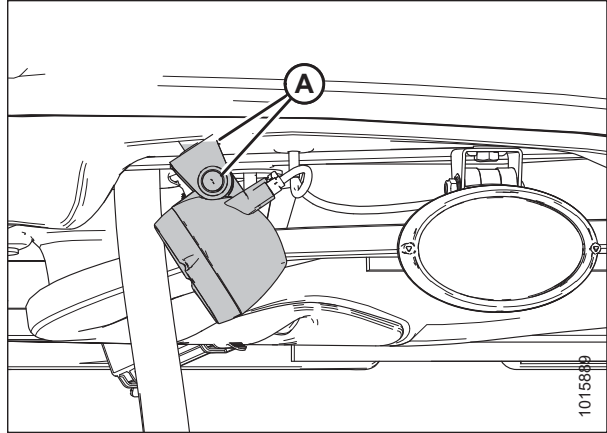

Figure 5.182: Left Rear Roof Work Light – Right Opposite

Adjusting Rear Swath Lights

Adjust rear swath lights to best suit Operator preference.

1. Stand on left or right platform (B) to access rear swath lights (A).

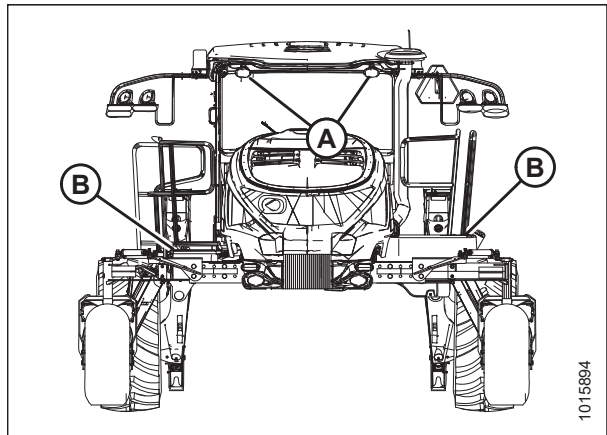

Figure 5.183: Rear Swath Lights

2. Adjust light position using bolts (A).

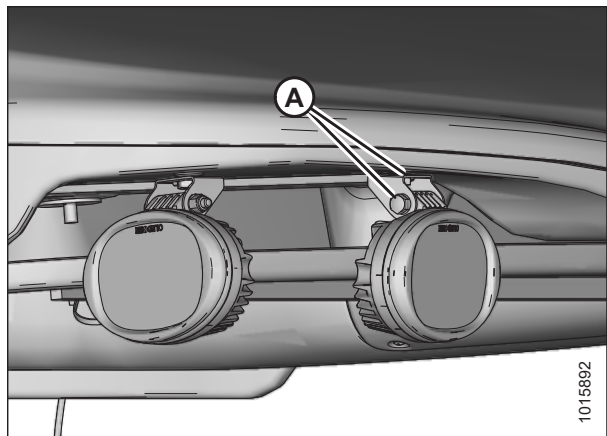

Figure 5.184: Left Rear Swath Light – Right Opposite

Replacing Bulbs in Standard Work Lights

The following procedure applies to all halogen bulbs shown in Figure 5.185, page 411. If replacing engine-forward headlight bulbs, refer to *Replacing Headlight Bulb – Engine-Forward*, page 412.

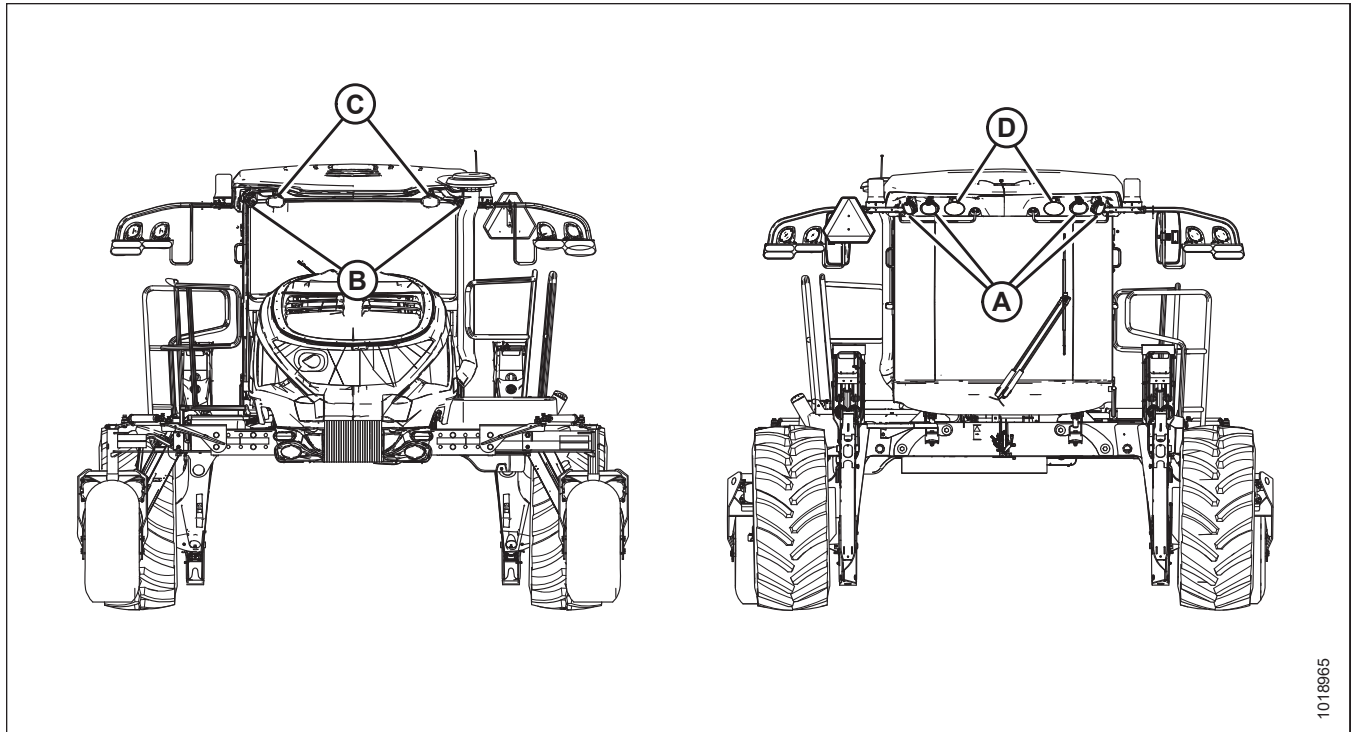

Figure 5.185: Halogen Bulb Locations

A - Front Work Lights (Field)

B - Stubble Lights (Rear)

C - Rear Work Lights

D - Headlights (Cab-Forward)

NOTE:

Front work light shown.

⚠ WARNING

To avoid bodily injury or death from unexpected startup of the machine, always stop the engine and remove the key from the ignition before leaving the operator’s seat for any reason.

1. Shut down the engine, and remove the key from the ignition.
2. Disconnect wiring harness (A).
3. Remove rubber insulator boot (B).
4. Remove bulb from body.

IMPORTANT:

Do **NOT** touch the glass of the halogen bulb as the oils or other chemicals from your skin will cause the bulb to fail prematurely.

5. Align lugs on new bulb with slots in housing and push into place.
6. Install insulator boot (B) and wiring harness (A).

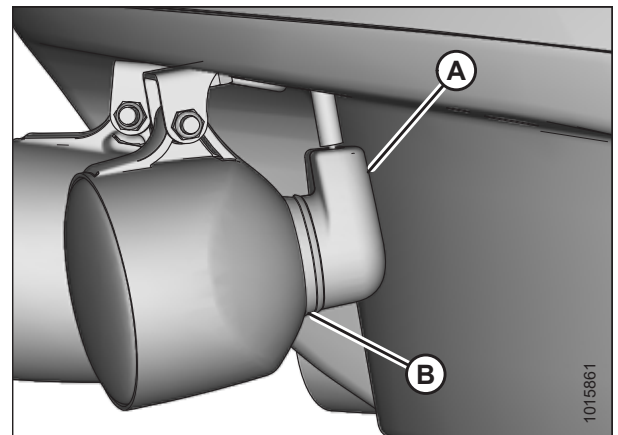

Figure 5.186: Front Work Light

Replacing Headlight Bulb – Engine-Forward

WARNING

To avoid bodily injury or death from unexpected startup of the machine, always stop the engine and remove the key from the ignition before leaving the operator’s seat for any reason.

1. Shut down the engine, and remove the key from the ignition.
2. Remove eight hex flange bolts (A), then remove headlight bezel assembly (B). Retain hardware.
3. Remove electrical connectors from red tail lights (C) to fully remove bezel (B).

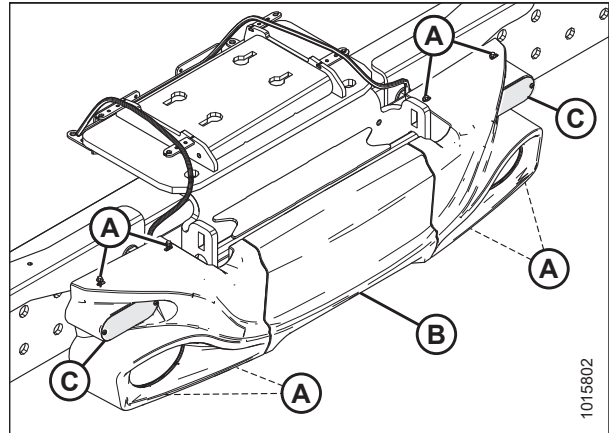

Figure 5.187: Headlight Bezel Assembly

4. Remove the two bolts (A) holding the headlight bracket assembly (B) in place and slide bracket forward.
5. Pull wiring harness connector off the headlight and remove assembly (B).

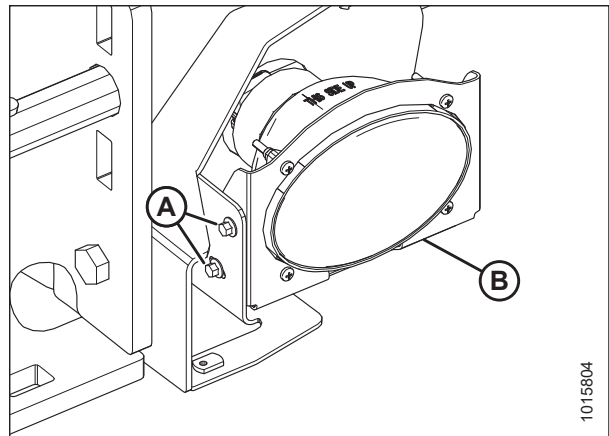

Figure 5.188: Right Headlight Shown – Left Similar

6. Remove four machine screws (A) and nylon nuts (B) and retain hardware.
7. Remove old headlight from bracket and replace with new headlight.

IMPORTANT:

Do **NOT** touch the glass of the halogen bulb as oils or other chemicals from your skin will cause the bulb to fail prematurely.

8. Attach headlight to bracket using four retained machine screws (A) and nylon nuts (B). Torque screws to 2.0–2.7 Nm (18–24 lbf·in).

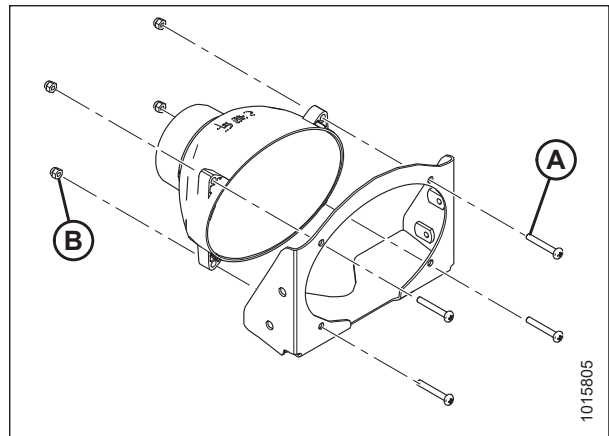

Figure 5.189: Right Headlight Shown – Left Similar

MAINTENANCE AND SERVICING

9. Connect wiring harness connector to headlight.
10. Attach headlight bracket assembly (B) using retained bolts (A).
11. Align new headlight. For instructions, refer to *Aligning Headlights – Engine-Forward*, page 406.

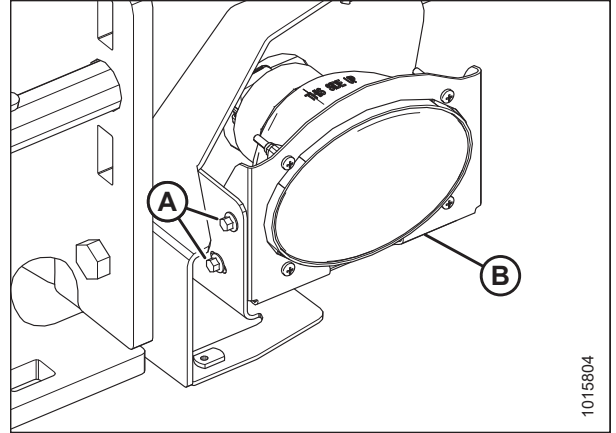

Figure 5.190: Right Headlight Shown – Left Similar

12. Attach electrical connectors to red tail lights (C).
13. Attach headlight bezel assembly (B) to frame using the eight retained hex flange bolts (A). Torque bolts to 2.0–2.7 Nm (18–24 lbf-in).

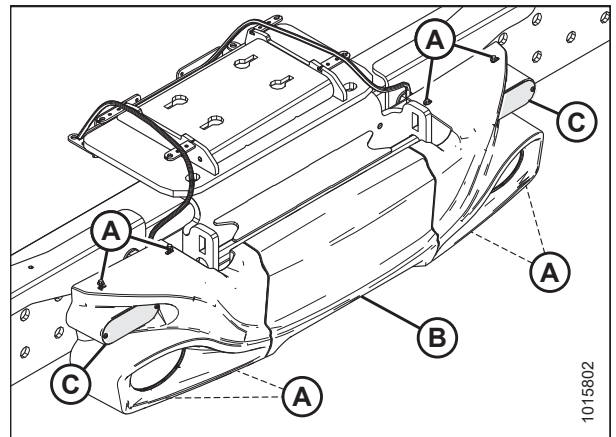

Figure 5.191: Headlight Bezel Assembly

Replacing LED Lights – Deluxe Cab Only

⚠ WARNING

To avoid bodily injury or death from unexpected startup of the machine, always stop the engine and remove the key from the ignition before leaving the operator's seat for any reason.

The M1240 Windrower deluxe cab is equipped with the following LED lights:

- Four LED field lights (A)
- Two LED stubble lights (B)
- Two LED rear work lights (C)

NOTE:

The bulb of an LED light cannot be replaced. For replacement parts, refer to the windrower parts catalog or contact your MacDon Dealer.

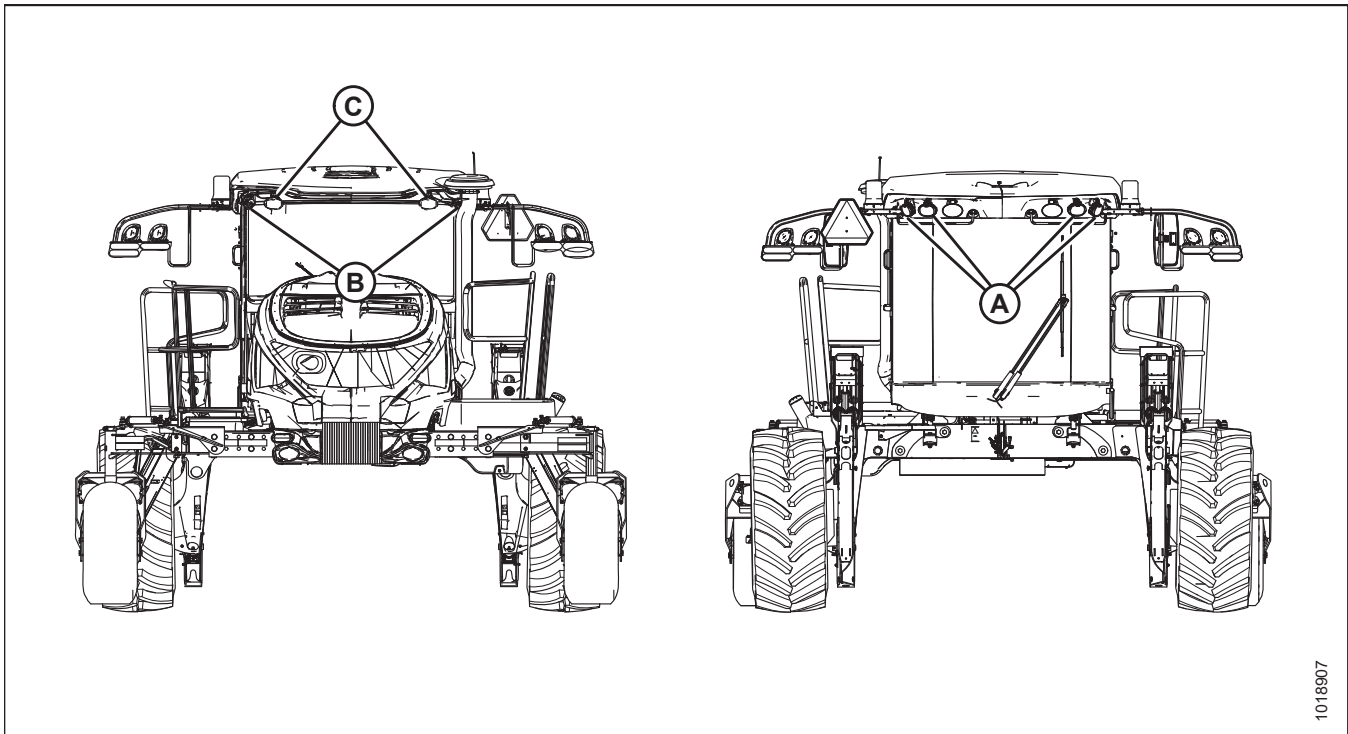

Figure 5.192: LED Light Locations – Deluxe Cab Only

Replacing Bulbs in Red and Amber Lights

To replace bulbs in red and amber lights, follow these steps:

WARNING

To avoid bodily injury or death from unexpected startup of the machine, always stop the engine and remove the key from the ignition before leaving the operator's seat for any reason.

1. Shut down engine and remove key. Turn lights OFF.

NOTE:

Hold onto the handholds on the cab front corners and stand on the header anti-slip strips, or stand on the maintenance platform when accessing the red and amber lights.

2. Use left or right platform to access marker lights (A) and (B) attached to mirror arms.

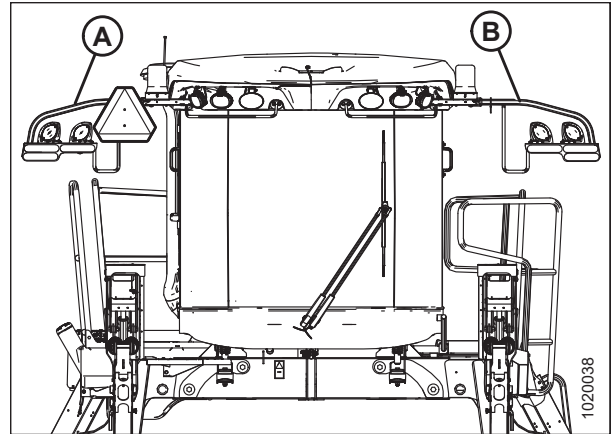

Figure 5.193: Cab-Forward Red and Amber Light Locations

3. Remove two screws (A) from lens and remove lens.
4. Push and twist light bulb to remove from socket.
5. Install a new bulb in the socket, ensuring that bulb base is properly engaged in socket.
 - Use Bulb Trade #1157 for red tail lights
 - Use Bulb Trade #1156 for amber lights
6. Reinstall lens with screws (A).

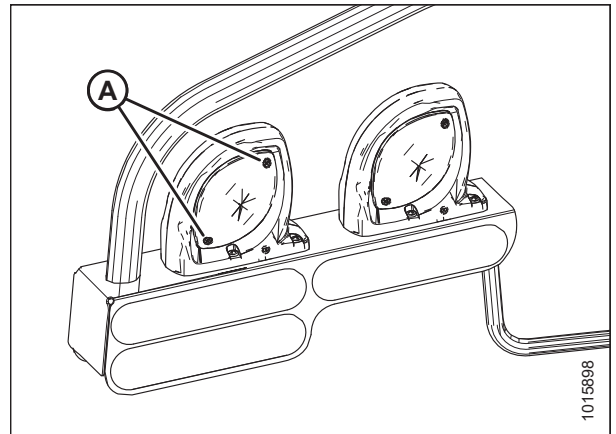

Figure 5.194: Red and Amber Lights

Replacing Red Tail Lights

WARNING

To avoid bodily injury or death from unexpected startup of the machine, always stop the engine and remove the key from the ignition before leaving the operator's seat for any reason.

1. Shut down engine and remove key. Turn lights OFF.
2. Remove two hex flange bolts (A) from light (B), and remove light from bezel.
3. Remove electrical connector from light (B).
4. Connect wiring harness to new light (B), and secure light to bezel using two hex flange bolts (A).

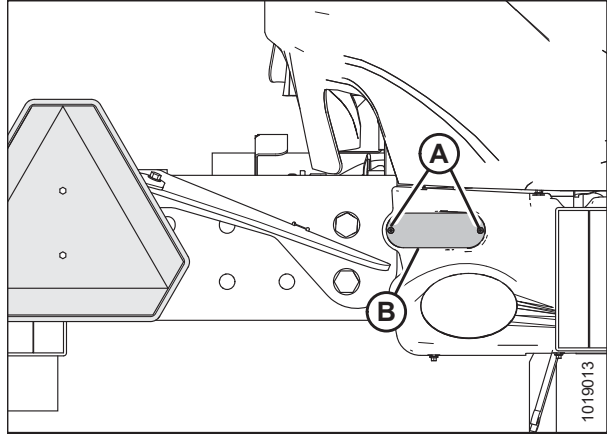

Figure 5.195: Red Tail Lights

Replacing Beacon Lights

1. Disconnect wiring (A) from harness.
2. Remove nuts (B) and remove beacon (C). Discard defective beacon and hardware.
3. Clean residue from support (D) mounting surface.
4. Install new beacon (C) with gasket (E) onto support. Secure with bolts (F), washers (G), and nuts (B).
5. Torque nuts to 0.65 Nm (0.48 lbf-ft).

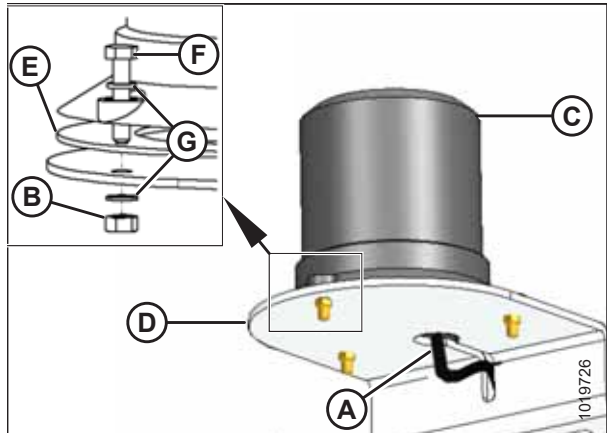

Figure 5.196: Beacon Light Assembly

Replacing the Cabin Dome Bulb

⚠ WARNING

To avoid bodily injury or death from unexpected startup of the machine, always stop the engine and remove the key from the ignition before leaving the operator's seat for any reason.

1. Shut down the engine, and remove the key from the ignition.
2. Insert a slotted screwdriver (or similar prying tool) into slot (A). Gently pry the lens cover until retaining tabs (B) are free of the dome light bezel.
3. Remove lens cover.

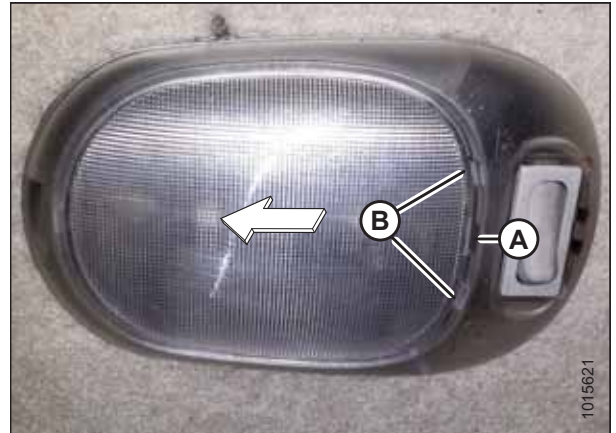

Figure 5.197: Cabin Dome Light

4. Replace bulb (A) (MD #208191).

IMPORTANT:

Do **NOT** touch glass with fingers.



Figure 5.198: Cabin Dome Light with Cover Removed

5. Insert single retaining tab (A) into dome light bezel.
6. Insert a slotted screwdriver (or similar prying tool) into slot (B), and gently pry lens cover until retaining tabs (C) engage into dome light bezel.

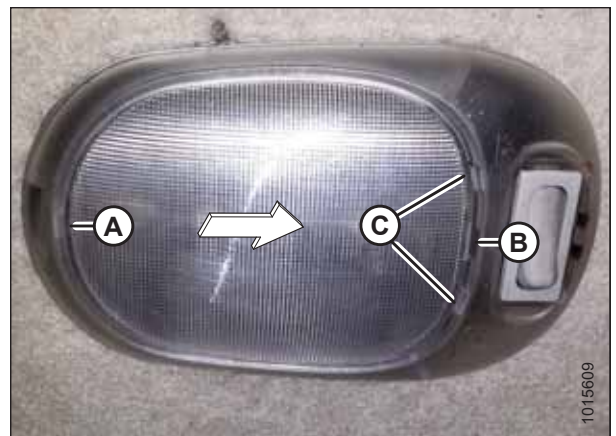

Figure 5.199: Cabin Dome Light

Replacing the Cabin Dome Light Assembly

⚠ WARNING

To avoid bodily injury or death from unexpected startup of the machine, always stop the engine and remove the key from the ignition before leaving the operator's seat for any reason.

1. Shut down the engine, and remove the key from the ignition.
2. Insert a slotted screwdriver (or similar prying tool) into slot (A). Gently pry the lens cover until retaining tabs (B) are free of the dome light bezel.
3. Remove lens cover.

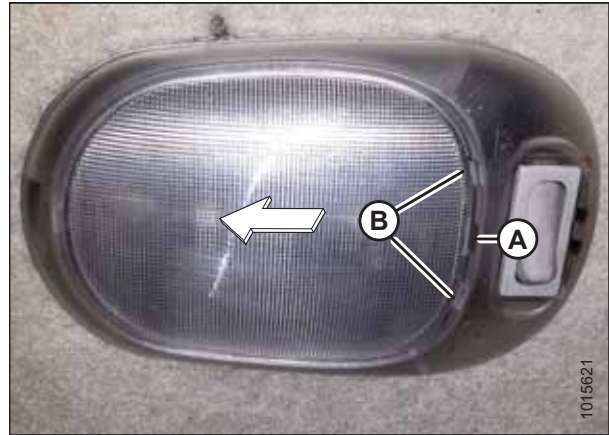

Figure 5.200: Cabin Dome Light

4. Remove two screws (A) from dome light bezel.

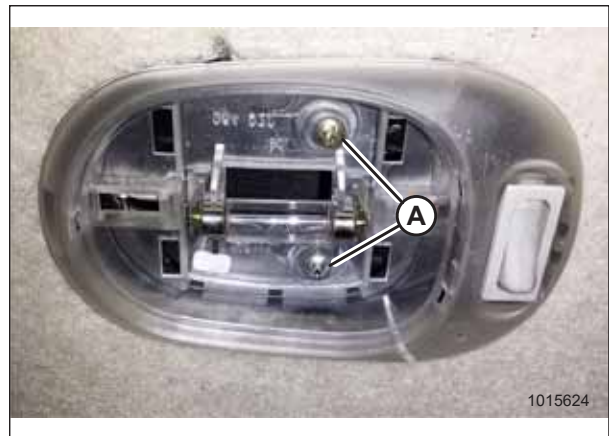

Figure 5.201: Cabin Dome Light with Cover Removed

5. Carefully insert a slotted screwdriver (or similar prying tool) between roof liner and dome light assembly on the side of the light with the ON/OFF switch.
6. Gently depress retaining clip (A), and swing dome light assembly downwards to disengage retaining tab (B).
7. Disconnect the old dome light assembly from the wiring harness.
8. Connect the new dome light (MD #201707) to the wiring harness.
9. Engage retaining tab (B), and swing dome light assembly upwards until retaining clip (A) snaps into place and secures assembly.

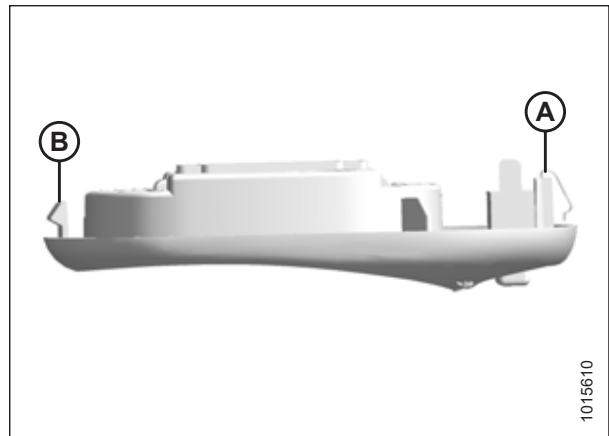

Figure 5.202: Cabin Dome Light Assembly

MAINTENANCE AND SERVICING

10. Secure dome light assembly with two screws (A).



Figure 5.203: Cabin Dome Light with Cover Removed

11. Insert single retaining tab (A) into dome light bezel.
12. Insert a slotted screwdriver (or similar prying tool) into slot (B), and gently pry lens cover until retaining tabs (C) engage into dome light bezel.

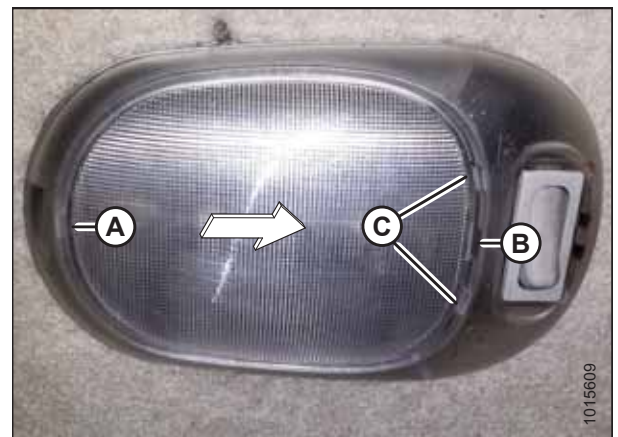

Figure 5.204: Cabin Dome Light

Turn Signal Indicators

If the turn signal indicators on the console do not function, contact your MacDon Dealer.

5.15.7 Accessing Circuit Breakers and Fuses

Most circuit breakers and fuses are located inside a fuse box mounted on the left (cab-forward) side of the frame, behind the platform and inside the battery cover.

NOTE:

The circuit breakers automatically reset. Fuses are the plastic blade type.

WARNING

To avoid bodily injury or death from unexpected startup of the machine, always stop the engine and remove the key from the ignition before leaving the operator's seat for any reason.

1. Stop engine and remove the key from the ignition.
2. Open the battery cover (A) to access the fuse box. For instructions, refer to *Opening Battery Cover, page 387*.

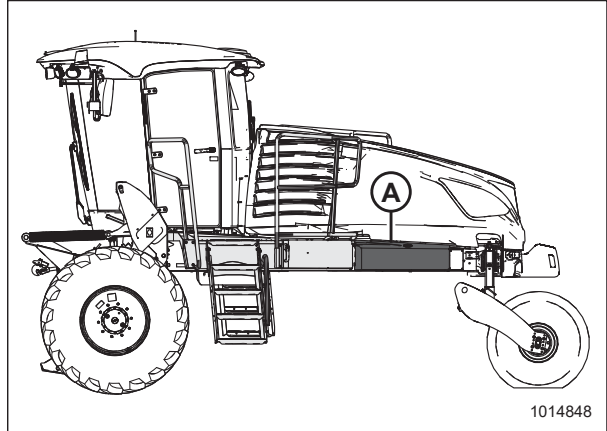

Figure 5.205: Fuse Box Location

3. Lift latch (A) at top of fuse box cover (B) to disengage tab, and then lower cover.
4. Check and replace fuses as required. For instructions, refer to *Checking and Replacing Fuses, page 421*.
5. Position cover (B) onto fuse panel, ensuring that hooks at bottom of cover have engaged fuse panel.
6. Push latch (A) to engage tab at top of fuse box.
7. Close battery cover and move platform to working position. For instructions, refer to *5.4.2 Closing Platform, page 304*.

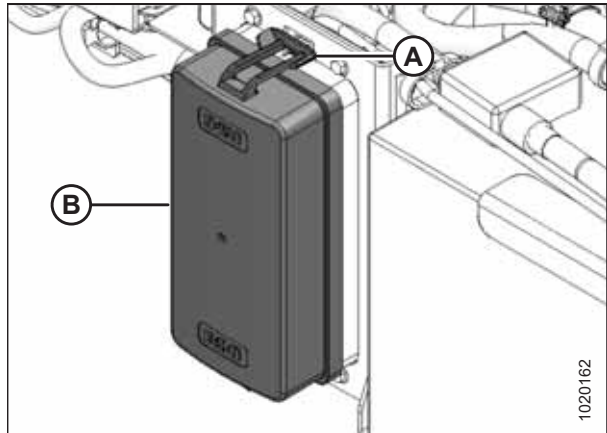

Figure 5.206: Fuse Box Cover

MAINTENANCE AND SERVICING

Checking and Replacing Fuses

1. To check fuse, pull fuse (A) out of receptacle and visually examine.
2. To replace fuse, insert new fuse into receptacle.

IMPORTANT:

Replacement fuses should match rating on decal shown on *Fuse Panel and Relay Module Decals, page 423*.

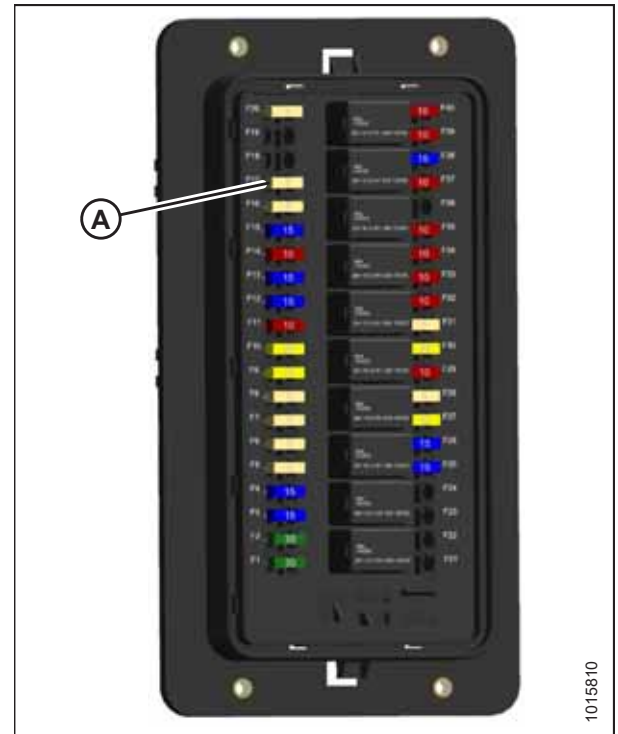

Figure 5.207: Fuses

Replacing Circuit Breakers and Relays

⚠ WARNING

To avoid bodily injury or death from unexpected startup of the machine, always stop the engine and remove the key from the ignition before leaving the operator's seat for any reason.

1. Shut down the engine, and remove the key from the ignition.
2. Open fuse box cover. For instructions, refer to [5.15.7 Accessing Circuit Breakers and Fuses](#), page 420.
3. To replace relay (A), pull relay out of receptacle and install new relay.
4. Reinstall cover.

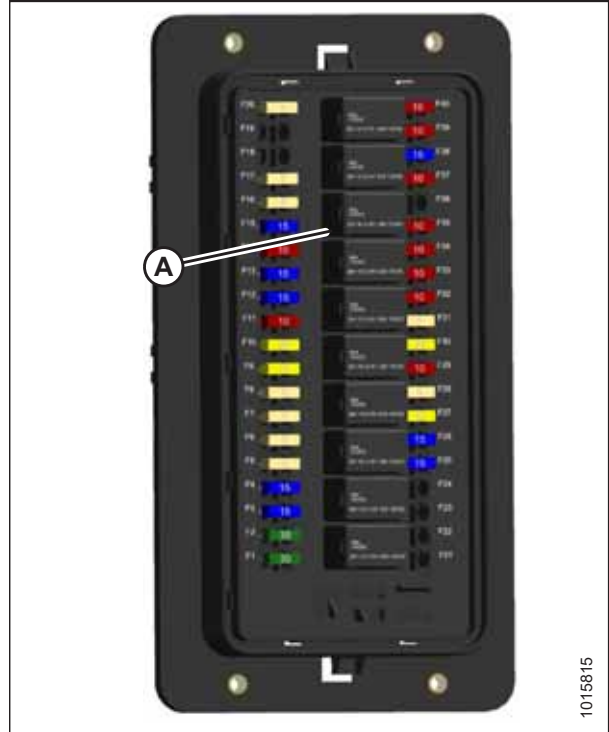

Figure 5.208: Fuse Box – Cover Removed

Fuse Panel and Relay Module Decals

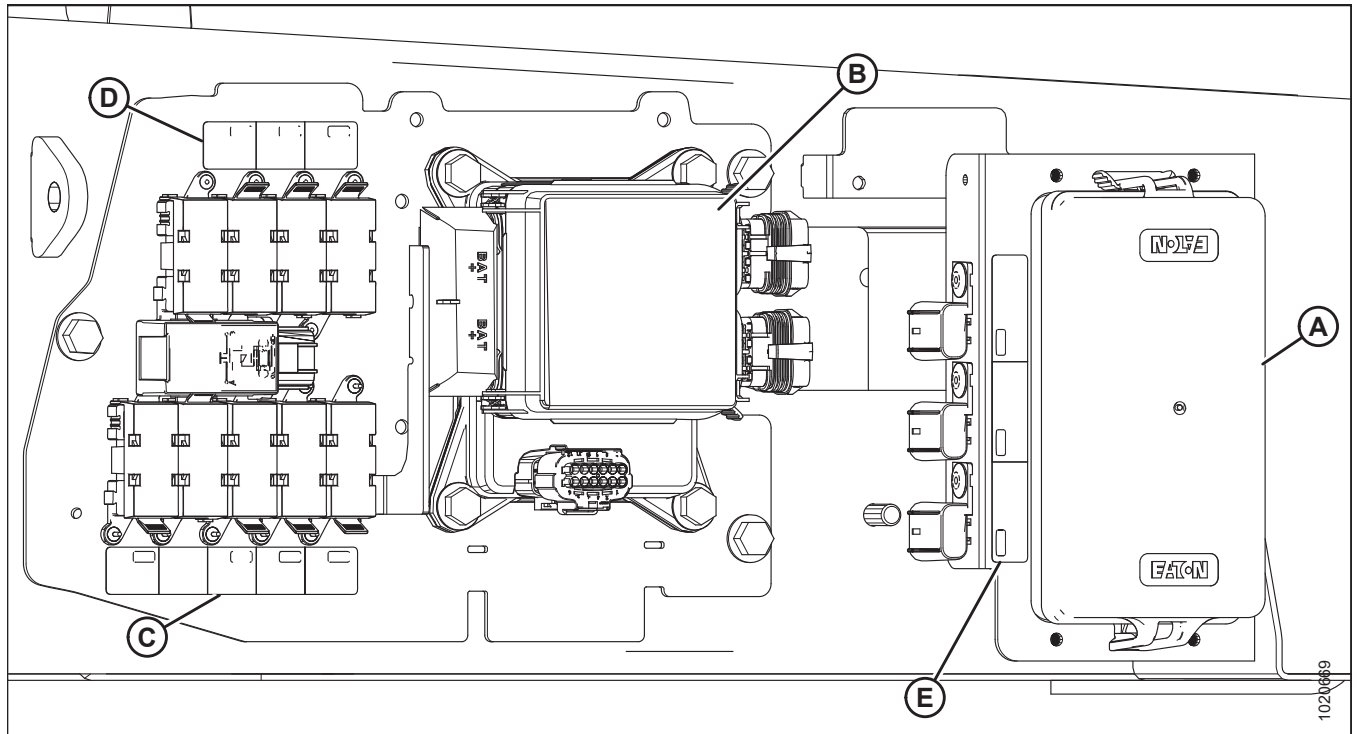

Figure 5.209: Left Rail Fuse Decal Locations

- A - Main Fuse Panel Decal (MD #208594) (Located inside Fuse Cover) (Group A)
- B - Chassis Relay Module Fuse Decal (MD #207816) (Located inside Fuse Cover) (Group B)
- C - Lower AMI Group Fuse Decal (MD #291378) (Group D)
- D - Upper AMI Group Fuse Decal (MD #207818) (Group D)
- E - ATO Group Fuse Decal (MD #291465) (Group C)

MAINTENANCE AND SERVICING

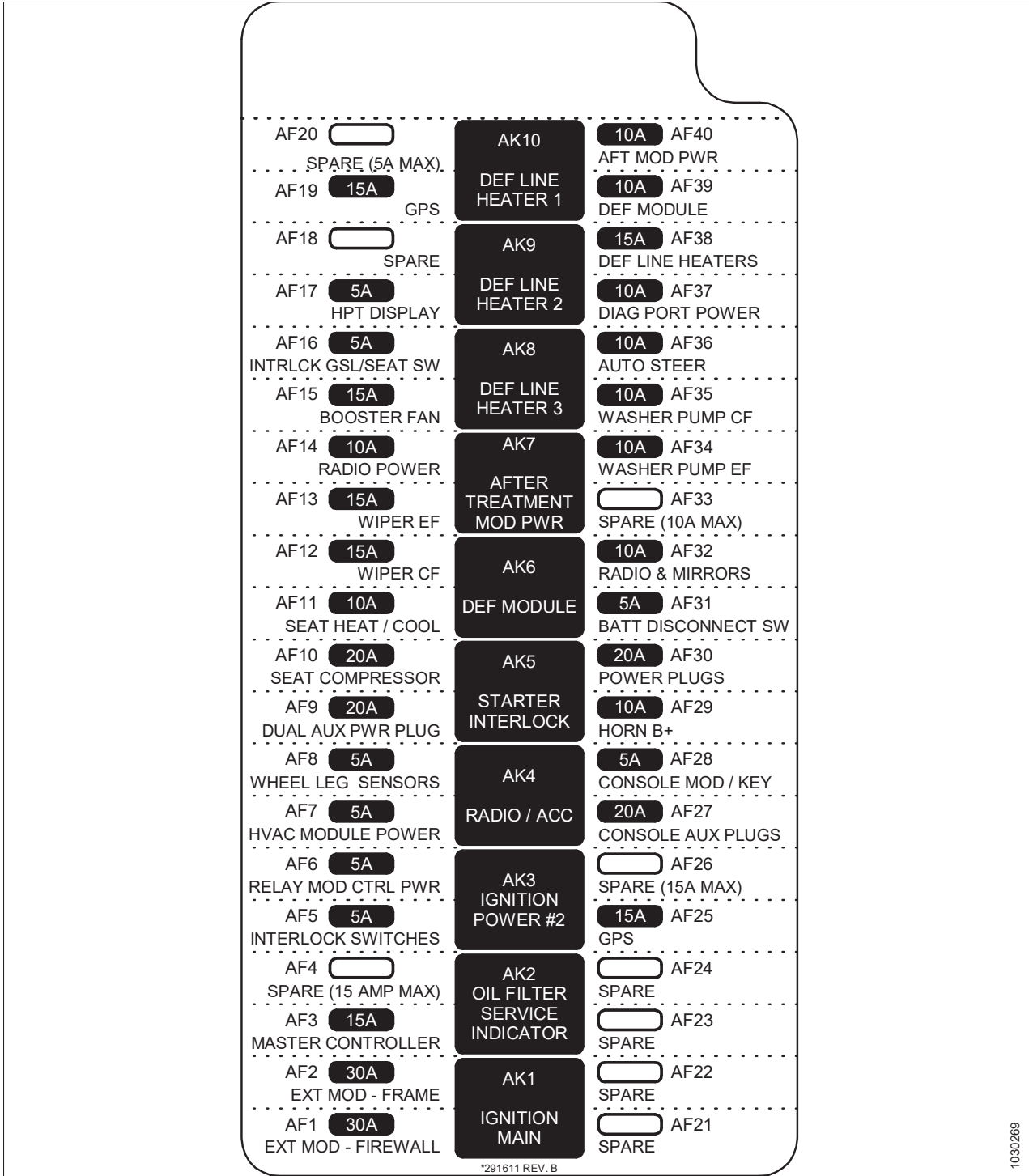

Figure 5.210: Main Fuse Panel Decal (MD #208594) – Group A

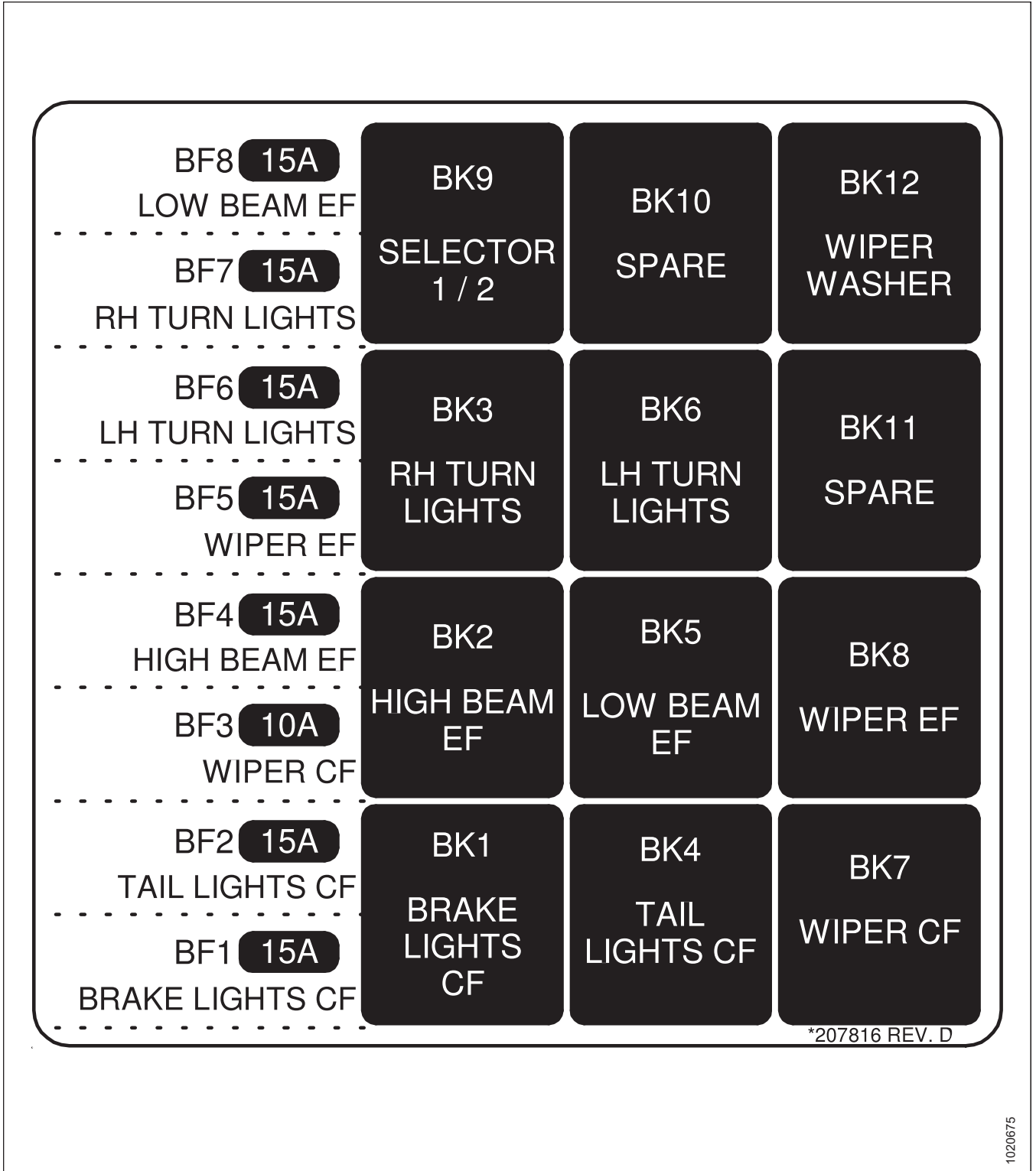

Figure 5.211: Chassis Relay Module Fuse Panel Decal (MD #207816) – Group B

1020675

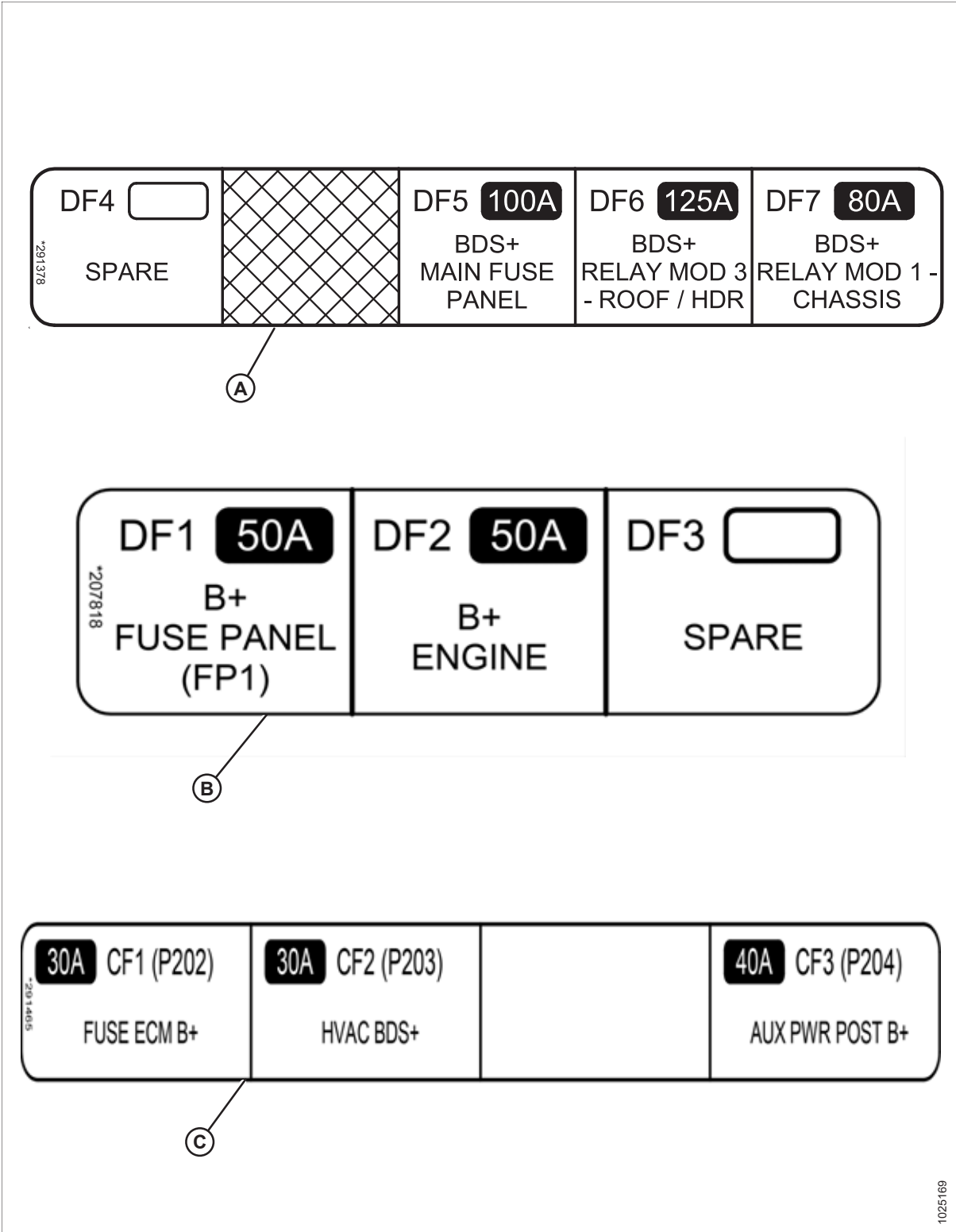

Figure 5.212: ATO (Group C) and AMI (Group D) Fuse Decals

A - Lower AMI Group Fuse Decal (MD #291378)

B - Upper AMI Group Fuse Decal (MD #207818)

C - ATO Group Fuse Decal (MD #291465)

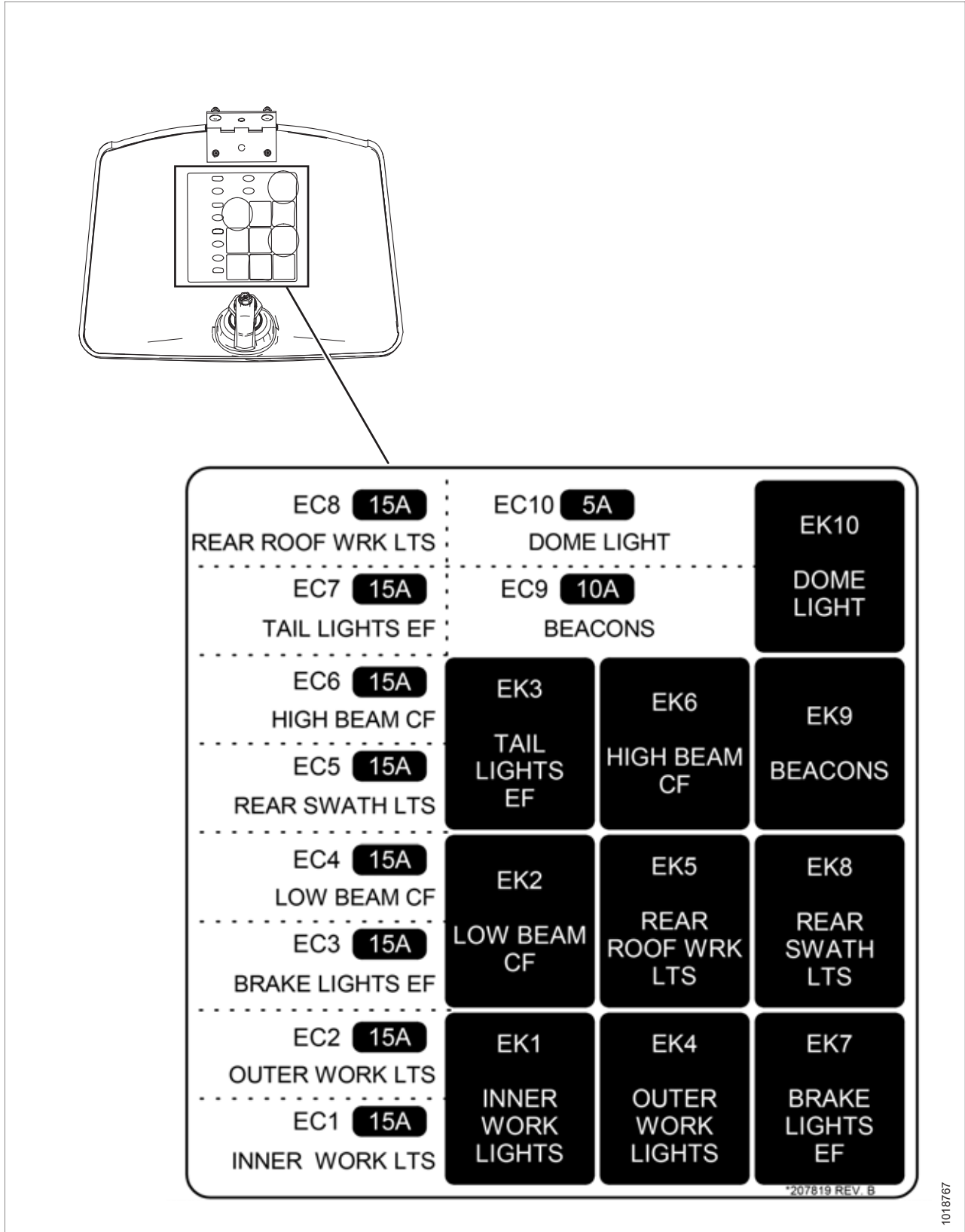

Figure 5.213: Roof Headliner Fuse Decal (MD #207819) – Group E

MAINTENANCE AND SERVICING

Inspecting and Replacing 125A Main Fuses

The 125A main fuse holders are located on the frame on the left cab-forward side platform beside the battery.

WARNING

To avoid bodily injury or death from unexpected startup of the machine, always stop the engine and remove the key from the ignition before leaving the operator's seat for any reason.

Access the 125A main fuses as follows:

1. Shut down the engine, and remove the key from the ignition.
2. Open the platform. For instructions, refer to [5.4.1 Opening Platform, page 304](#).
3. Remove negative battery terminal.
4. Locate the five main fuses (A) secured to the left cab-forward front frame.

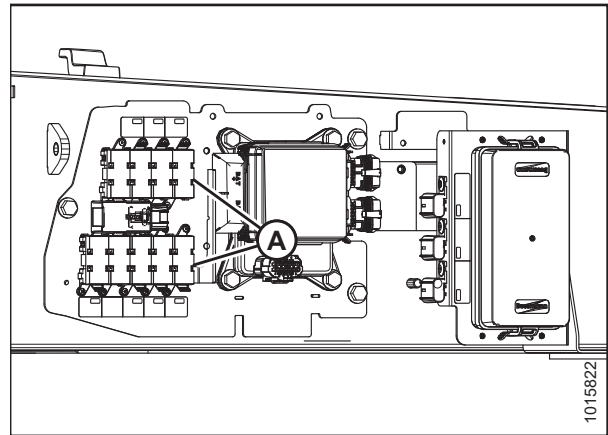

Figure 5.214: Main Fuses

5. To check condition of the fuse, pull tab (A) and open cover (B).

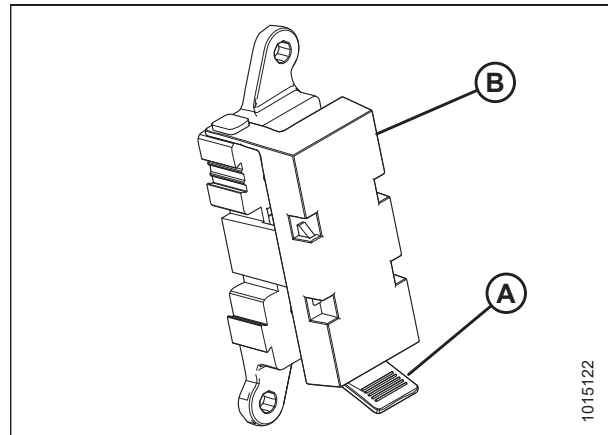

Figure 5.215: 125A Main Fuse

MAINTENANCE AND SERVICING

6. Examine fuse (A) for indications of melting.
7. To remove fuse (A), remove two nuts (B) and pull the fuse free from holder (existing wiring may need to be pulled off the stud first).
8. Install the new fuse on studs and install any existing wiring that was removed.
9. Secure with nuts (B).

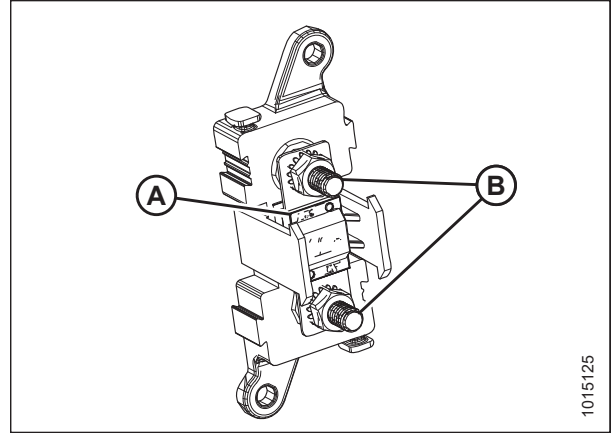

Figure 5.216: 125A Main Fuse

10. Close cover (B) and secure with tab (A).
11. Close the platform. For instructions, refer to [5.4.2 Closing Platform, page 304](#).

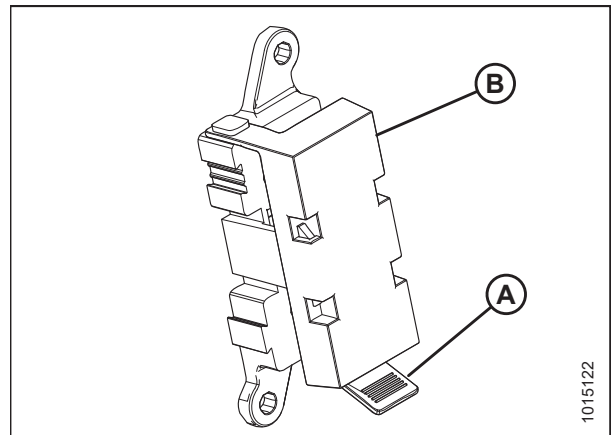

Figure 5.217: 125A Main Fuse

5.15.8 Drive Wheels

Raising Drive Wheel

This procedure applies to both drive wheels.

WARNING

To avoid bodily injury or death from unexpected startup of the machine, always stop the engine and remove the key from the ignition before leaving the operator's seat for any reason.

CAUTION

Header **MUST** be removed and **NO** weight box installed. Use a hydraulic jack with minimum lifting capacity of 2268 kg (5000 lb.) to provide adequate support for the machine.

1. Detach the header.
2. Park the windrower on a level surface.
3. Block the wheels.

MAINTENANCE AND SERVICING

4. Place the ground speed lever (GSL) (A) in PARK.
5. Shut down the engine, and remove the key from the ignition.

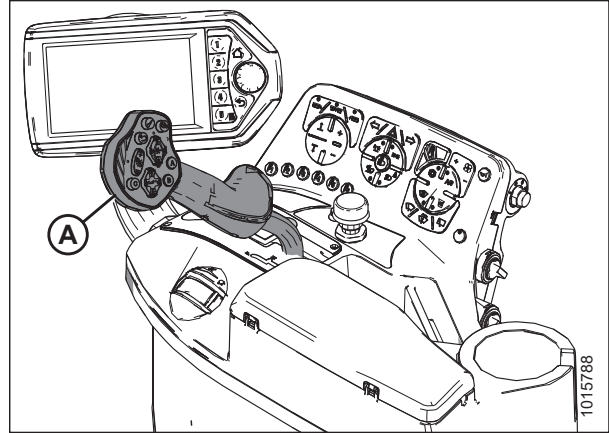

Figure 5.218: Ground Speed Lever

6. Place a jack under the leg jack point (A). Raise the drive wheel until it is slightly off the ground.
7. Place a jack stand beneath the lift cylinder mount (B).

NOTE:

Do **NOT** place jack stand under the cylinder. Use a small metal plate on top of the jack stand.

8. Lower the windrower onto the jack stand.

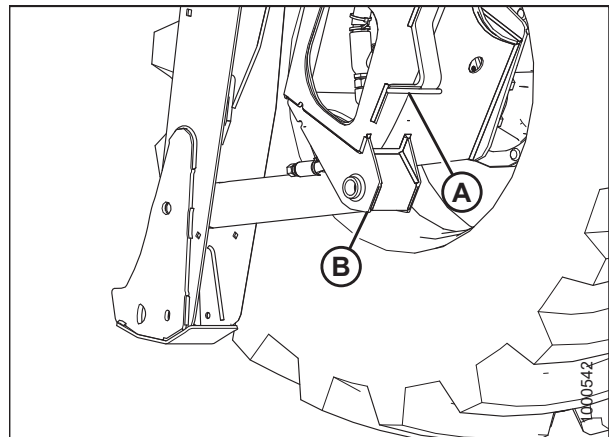

Figure 5.219: Drive Wheel Jack Point

Removing Drive Wheels

CAUTION

Use a suitable lifting device capable of supporting a minimum of 907 kg (2000 lb.) to lift the wheel assembly away from the windrower.

1. Raise windrower drive wheel (A) off the ground. For instructions, refer to [Raising Drive Wheel, page 429](#).
2. Remove wheel nuts (B).
3. Remove drive wheel (A).

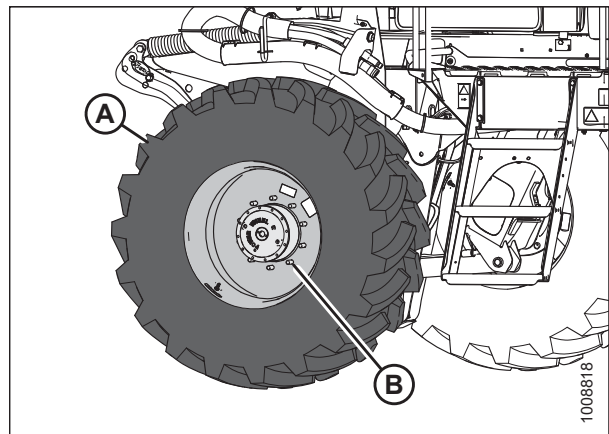

Figure 5.220: Drive Wheel Assembly

Installing Drive Wheels

CAUTION

Use a lifting device capable of supporting a minimum of 907 kg (2000 lb.) to lift the wheel assembly.

IMPORTANT:

The windrower must be supported off the ground with stands. For instructions, refer to *Raising Drive Wheel, page 429*.

1. Using a forklift, lift cab end of windrower to approximately 130 cm (51 in.) (B) off the ground, enough to position the drive wheel assembly (A). Place a stand (C) under the windrower frame.

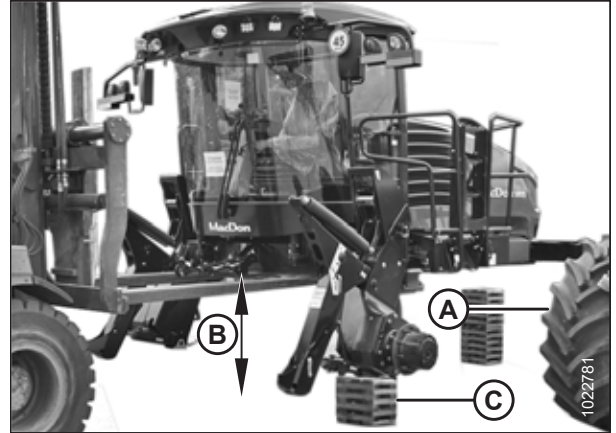

Figure 5.221: Supporting Windrower

2. Clean mounting surface on wheel drive and rim.

3. Position a suitable lifting device (A) under the tire and raise slightly.
4. Position the wheel against wheel drive hub so air valve (B) is on the outside and tread (C) points forward (cab-forward orientation).

NOTE:

For turf tires (diamond tread pattern), be sure the arrow on the sidewall points in forward rotation (cab-forward).

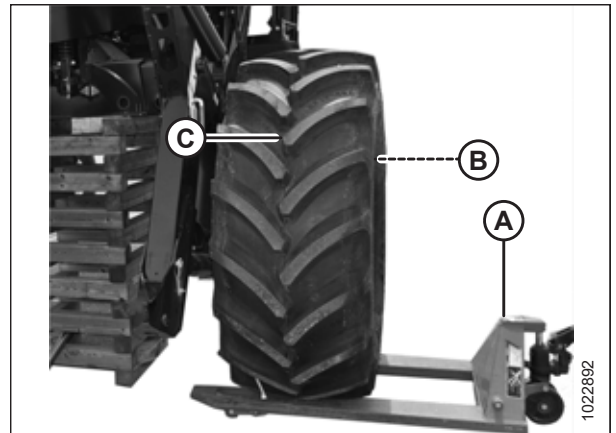

Figure 5.222: Drive Wheel

MAINTENANCE AND SERVICING

- Align the rim with studs on the hub and push the wheel onto the hub.
- Install wheel nuts (A).

IMPORTANT:

To avoid damage to wheel rims and studs, do **NOT** use an impact wrench. Threads must be clean and dry. Do **NOT** apply lubricant or anti-seize compound. Do **NOT** overtighten wheel nuts.

- Torque drive wheel nuts. For instructions, refer to [5.6.1 Tightening Drive Wheel Nuts, page 323](#).

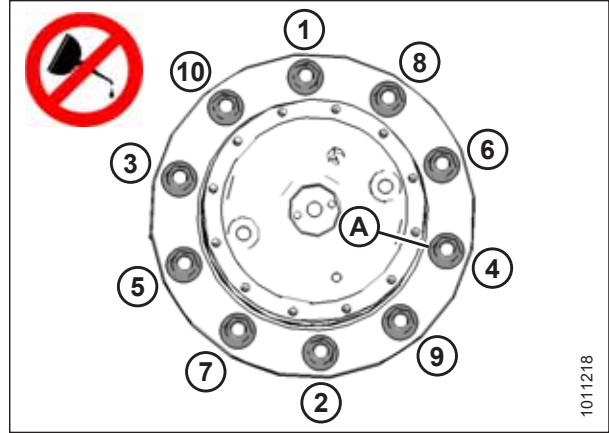

Figure 5.223: Tightening Sequence – Ten Bolt Wheel

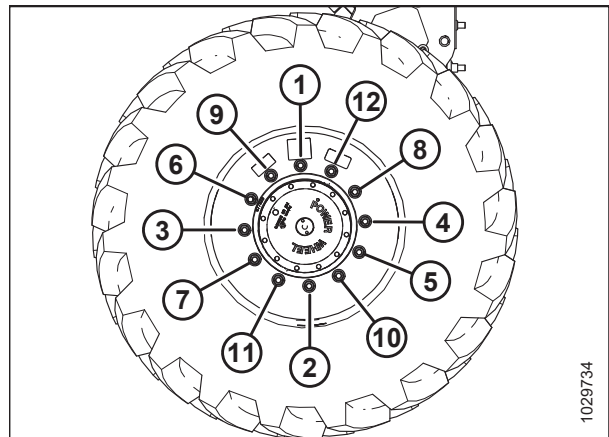

Figure 5.224: Tightening Sequence – Twelve Bolt Wheel

- Repeat the tightening sequence two additional times, ensuring the specified torque is achieved each time.
- Repeat Steps [2, page 431](#) to [8, page 432](#) for the other drive wheel.
- Raise the windrower, remove the stand, and lower windrower to the ground.
- Lower the windrower. Remove the jack. For instructions, refer to [Lowering Drive Wheel, page 433](#).
- Repeat the torque procedure every hour of operation until two consecutive checks confirm that there is no movement of the nuts.

Lowering Drive Wheel

CAUTION

Jack stand must be capable of supporting a minimum of 2268 kg (5000 lb.).

1. Place a jack under leg jack point (A), and raise the drive wheel slightly off the jack stand.
2. Remove the jack stand from under cylinder lift mount (B). Lower the drive wheel to the ground.
3. Remove the jack.

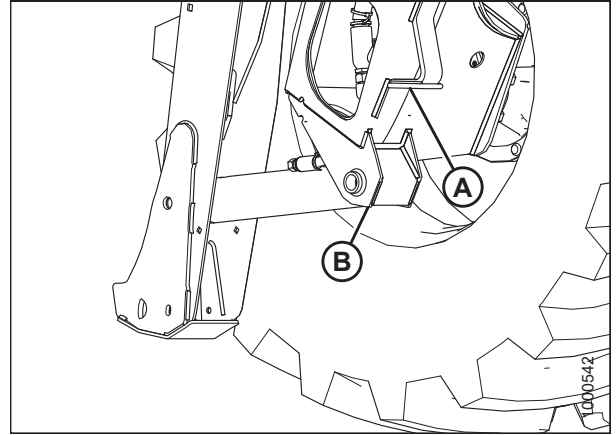

Figure 5.225: Drive Wheel Leg Jacking Point

5.15.9 Caster Wheels

Adjusting Caster Tread Width

The rear casters can be adjusted to a narrow tread width, which allows loading and shipping without having to remove them.

A narrow tread width is better suited for smaller headers because it allows more space to the uncut crop, and provides more maneuverability around poles, irrigation inlets, and other obstacles.

A wider tread width reduces runover in heavy crops that produce large windrows.

WARNING

To avoid bodily injury or death from unexpected startup of the machine, always stop the engine and remove the key from the ignition before leaving the operator's seat for any reason.

CAUTION

Park on a flat, level surface with the header on the ground, the ground speed lever (GSL) in PARK position, and the steering wheel in locked position (centered). Wait for the HPT to beep and display a red P symbol to confirm the park brakes have engaged.

1. Park the windrower on a level surface.
2. Place the ground speed lever (GSL) in PARK.
3. Shut down the engine, and remove the key from the ignition.

MAINTENANCE AND SERVICING

- Using a jack (or another lifting device) under the frame at location (A), slightly raise the rear of the windrower until most of the weight is off the casters.

IMPORTANT:

Do **NOT** damage the engine oil pan when raising the windrower.

NOTE:

Lifting device must have a lifting capacity of at least 4536 kg (10,000 lb.).

- Remove six bolts (B) (four on backside, two on underside) and washers from the left and right sides of the walking beam.

- Slide the left and right extensions equal distances in either the inboard or outboard directions, and align its holes at the desired locations.

NOTE:

To assist moving the extensions, rotate the caster so the wheel is parallel to the walking beam.

IMPORTANT:

Ensure the caster wheels are positioned at equal distances from the center of the windrower.

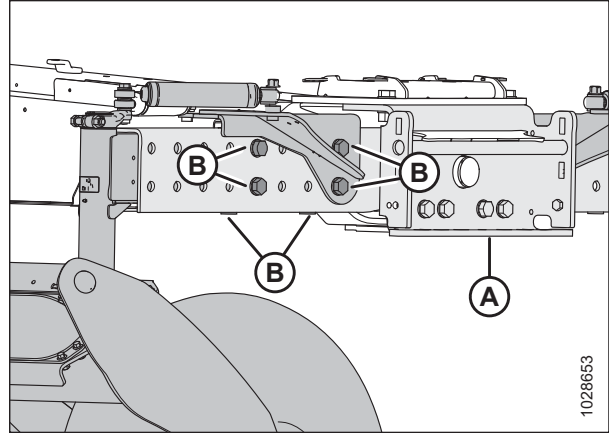

Figure 5.226: Left Caster Wheel Extension

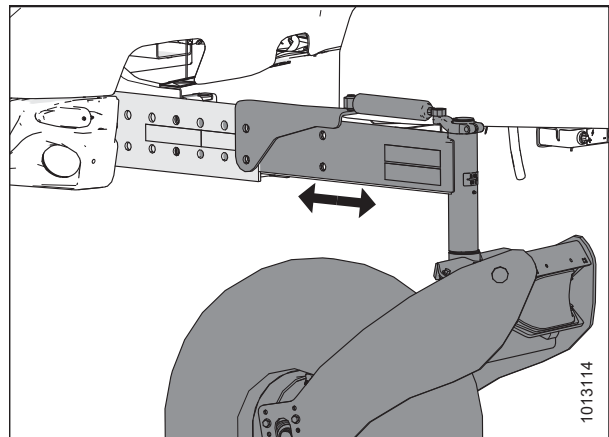

Figure 5.227: Right Caster Wheel Extension

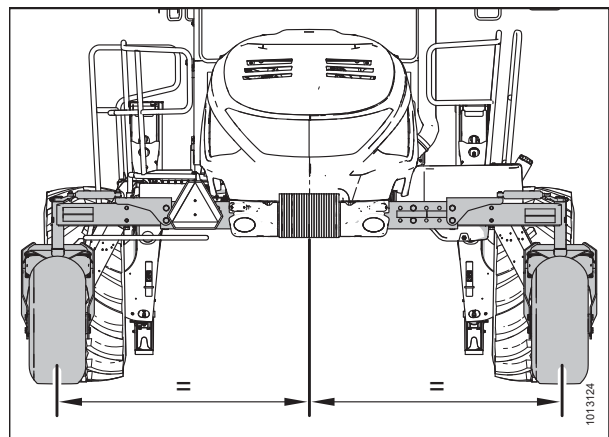

Figure 5.228: Adjustable Caster Wheels

MAINTENANCE AND SERVICING

7. Position bracket (A) and install back bolts (C).
8. Install bottom bolts (B).
9. Tighten bolts as follows:
 - a. Snug bottom bolts (B), then snug back bolts (C).
 - b. Tighten and torque back bolts (C) to 746–770 Nm (550–570 lbf-ft).
 - c. Tighten and torque bottom bolts (B) to 746–770 Nm (550–570 lbf-ft).
10. Repeat Step 7, page 435 to Step 9, page 435 on the opposite side.
11. Lower the windrower to the ground.

IMPORTANT:

Torque bolts after first 5 and 10 hours of operation.

Installing Forked Caster Wheel

1. Position axle assembly (B) into wheel (C) and secure with wheel nuts (A).

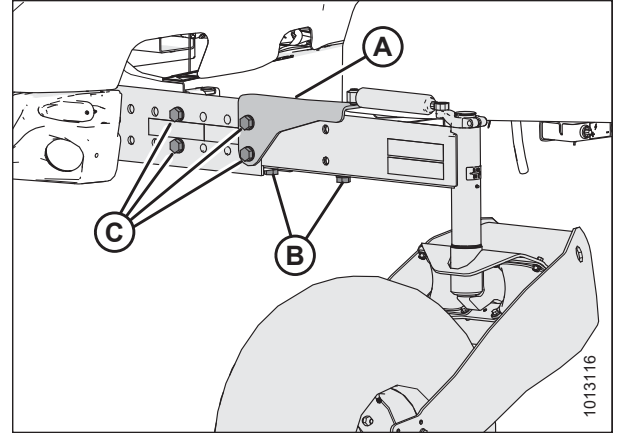

Figure 5.229: Caster Wheel Extensions

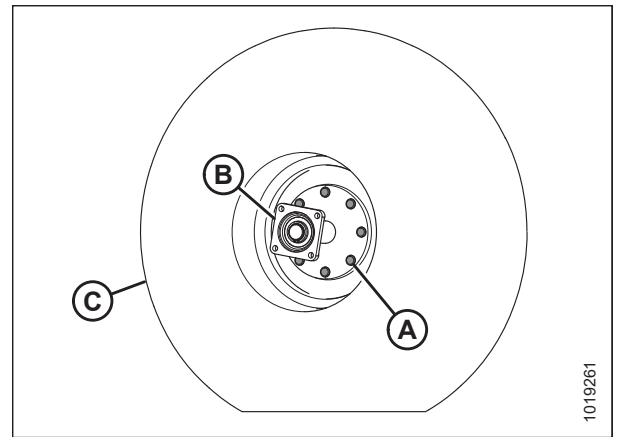

Figure 5.230: Caster Wheel Assembly

2. Tighten wheel nuts (A) to 163 Nm (120 lbf-ft) using the tightening sequence shown at right. Repeat the tightening sequence three times.

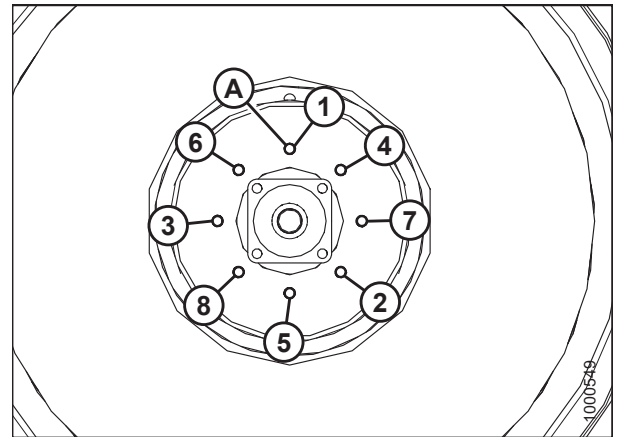

Figure 5.231: Caster Wheel Tightening Sequence

MAINTENANCE AND SERVICING

3. Position wheel assembly (D) in forked caster (C).
4. Install eight bolts (A) and nuts (four on each side of caster) to secure axle (B) to caster (C). Torque nuts to 97–107 Nm (75–79 lbf·ft).
5. Lower caster wheel. For instructions, refer to [Lowering Caster Wheel, page 437](#).

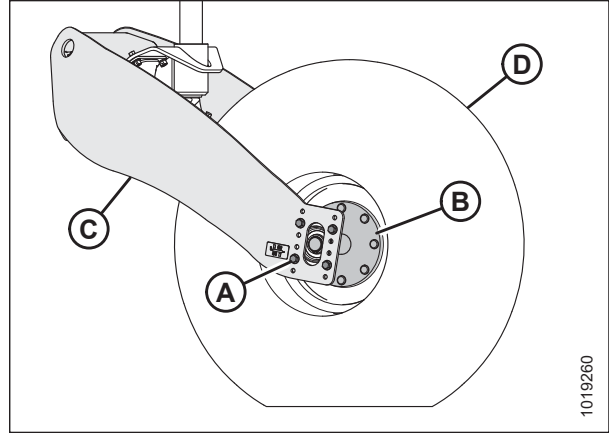

Figure 5.232: Caster Wheel Assembly

Removing Forked Caster Wheel

CAUTION

Wheel assemblies are heavy. Support wheel assembly before removing axle bolts.

1. Raise caster wheel. For instructions, refer to [Raising Caster Wheel, page 437](#).
2. Remove eight bolts (A) and nuts (four of each on each side of caster) attaching axle (B) to forked caster (C), and remove wheel assembly (D) from caster (C).

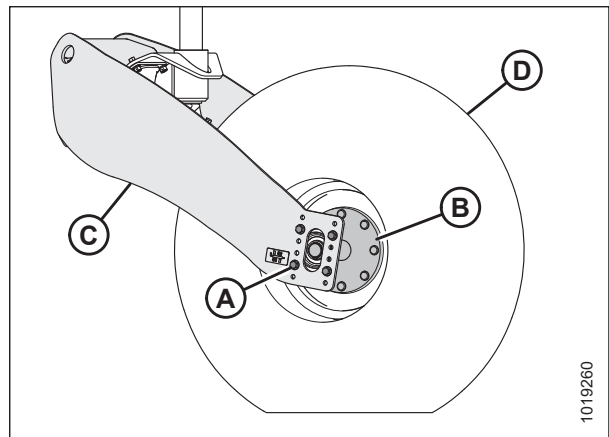

Figure 5.233: Caster Wheel Assembly

3. Remove eight wheel nuts (A) that secure axle (B) to wheel (C).
4. Separate axle (B) and wheel (C).

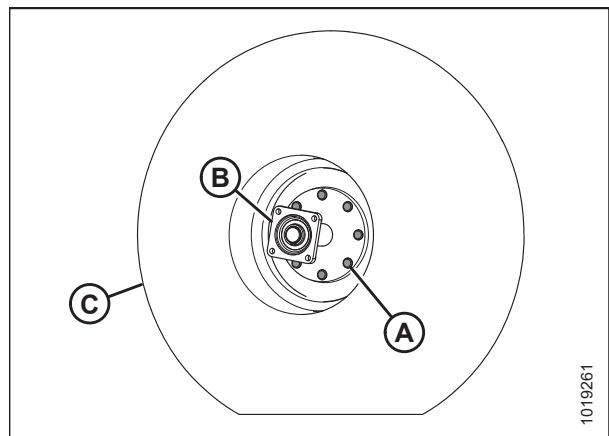

Figure 5.234: Caster Wheel Assembly

MAINTENANCE AND SERVICING

Lowering Caster Wheel

1. Raise the end of walking beam (A) slightly, using a suitable lifting device capable of lifting minimum 2268 kg (5000 lb.).
2. Remove the jack stand, and lower the end of the walking beam until the caster wheel assembly (B) is on the ground.
3. Remove blocks from the drive tires.

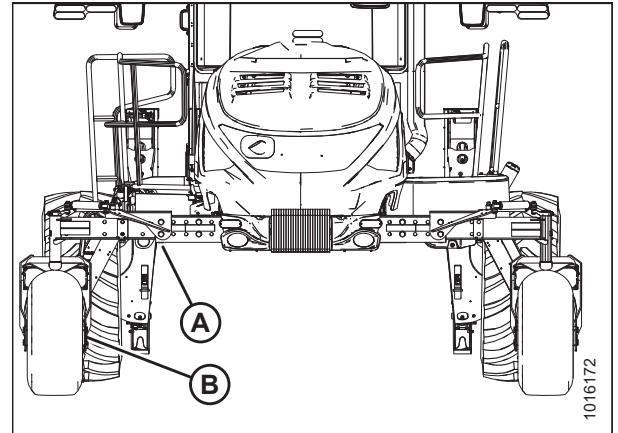

Figure 5.235: Caster Wheel Assembly

Raising Caster Wheel

This procedure is for raising the caster wheel. This procedure applies to both caster wheels.

1. Park the windrower on a level surface.
2. Block the wheels.
3. Place the ground speed lever (GSL) (A) in PARK.
4. Shut down the engine, and remove the key from the ignition.

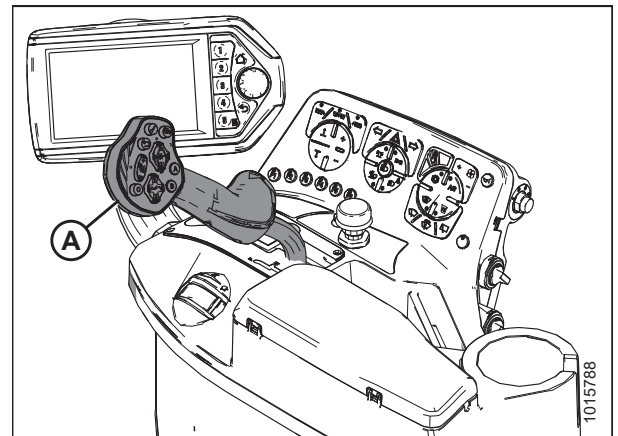

Figure 5.236: GSL Position

5. Raise the end of walking beam (A) until the caster wheel assembly (B) is slightly off the ground. Use a suitable lifting device, capable of lifting 2268 kg (5000 lb.) minimum.
6. Place a jack stand beneath the walking beam and lower the beam until resting on the stand.

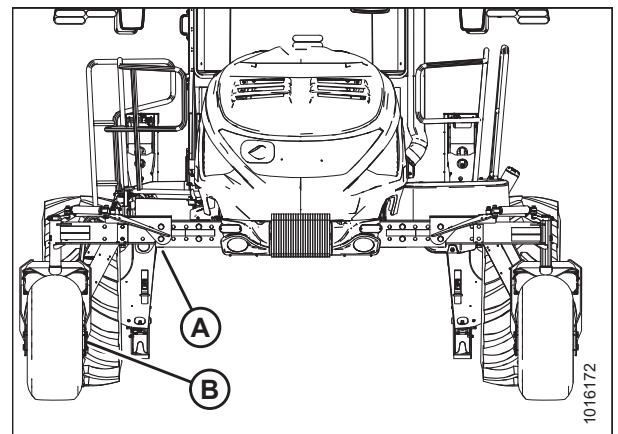

Figure 5.237: Caster Wheel Assembly

Chapter 6: Options and Attachments

6.1 Cab

6.1.1 Automated Steering Systems

A MacDon-approved automated steering system is available from MacDon Dealers that provide Trimble® global positioning system (GPS) installation and support services.

MacDon windrowers are partially pre-wired for either the Trimble® AutoPilot™ hydraulically integrated steering system or the Trimble® EZ-Pilot® wheel/column-based assisted steering system. The windrower's ground speed lever (GSL) has an automated steering (autosteer) engage switch.

The Trimble® EZ-Pilot® system for model year 2019 and later machines requires the MacDon EZ-Pilot® Ready kit (MD #B6602). Installation instruction (MD #214623) is included in the bundle.

The Trimble® AutoPilot™ system for model year 2019 and later machines requires the MacDon Trimble® Autopilot™ Ready kit (MD #B6601). Installation instruction (MD #214624) is included in the bundle.

Other GPS providers may supply parts in their vehicle-specific installation packages or make installation kits available through MacDon Dealers.

6.1.2 Windrower Lighting Upgrade – Eight LED Work Lights, Standard on Deluxe Cab Package

The standard windrower cab has four halogen field lights on the front, as well as two halogen stubble lights and two halogen work lights on the back. The Windrower Lighting Upgrade kit (MD #B6889) contains eight LED work lights to replace all of these lights. Machines with the deluxe cab package already have 360° Night Vision LED Lighting installed.

MD #B6889

Installation instructions are included in the bundle.

NOTE:

This lighting upgrade is included in the deluxe cab package.

6.2 Header Operation

6.2.1 Conversion Kit for Disc Ready to Disc, Auger, and Draper Ready

Used to convert a M1240 from Disc Ready to Disc, Draper, and Auger ready.

MD #B5999

Instruction MD #147822 is included in the bundle.

6.2.2 Booster Spring Kit – External

This kit is available for headers over 2812 kg (6200 lb.) to increase float capacity.

MD #B6047 – Booster Spring kit (external) includes two springs (one for each side) and mounting brackets. Kit instruction MD #147825 is included in the bundle.

There is also a Double Booster Spring kit (MD #B6106) that is used together with the Booster Spring kit (external) to add on a second booster spring. Refer to [6.2.3 Double Booster Spring Kit – External, page 441](#).

Table 6.1 Available Float Spring Kits for Different Header Types and Configurations

Header Type	Description	Header Configuration	Additional Float Spring Kits
D130XL	9.1 m (30 ft.) single reel, double knife, timed	Transport	—
D130XL	9.1 m (30 ft.) single reel, double knife, timed	Transport Upper Cross Auger Vertical Knives	MD #B6047
D135XL	10.8 m (35 ft.) single reel, double knife, untimed	Base	—
D135XL	10.8 m (35 ft.) single reel, double knife, untimed	Transport	MD #B6047
D135XL	10.8 m (35 ft.) single reel, double knife, untimed	Transport Upper Cross Auger Vertical Knives	MD #B6047
D135XL	10.8 m (35 ft.) double reel, double knife, untimed	Base	—
D135XL	10.8 m (35 ft.) double reel, double knife, untimed	Transport	MD #B6047
D135XL	10.8 m (35 ft.) double reel, double knife, untimed	Transport Upper Cross Auger Vertical Knives	MD #B6047
D140XL	12.2 m (40 ft.) double reel, double knife, untimed	Base	—

OPTIONS AND ATTACHMENTS

Table 6.1 Available Float Spring Kits for Different Header Types and Configurations (continued)

Header Type	Description	Header Configuration	Additional Float Spring Kits
D140XL	12.2 m (40 ft.) double reel, double knife, untimed	Transport	MD #B6047
D140XL	12.2 m (40 ft.) double reel, double knife, untimed	Transport, Upper Cross Auger, Vertical Knives	MD #B6047
D145XL	12.2 m (40 ft.) double reel, double knife, untimed	Base	MD #B6047
D145XL	12.2 m (40 ft.) double reel, double knife, untimed	Transport	MD #B6047

6.2.3 Double Booster Spring Kit – External

Available for headers over 2812 kg (6200 lb.) to increase the float capacity.

The Double Booster Spring kit (MD #B6106) is used together with the Booster Spring kit (MD # B6047) to add a second booster spring. Refer to [6.2.2 Booster Spring Kit – External, page 440](#). Kit instruction MD #147826 is included in the bundle.

Table 6.2 Available Float Spring Kits for Different Header Types and Configurations

Header Type	Description	Header Configuration	Additional Float Spring Kits
D145XL	13.7 m (45 ft.) double reel, double knife, untimed	Transport Upper Cross Auger Vertical Knives	MD #B6106

6.2.4 Double Windrow Attachment

This kit allows auger and rotary headers to lay a double windrow when installed on a windrower. The kit includes a draper deck, linkage assembly, hydraulics, and installation instructions.

MD #C2070 consists of:

- MD #B6693 – Deck
- MD #B6694 – Mounting frame and hydraulic/electrical connections
- Double Windrow Attachment (DWA) manual

6.2.5 Double Windrow Attachment Shut-Off Kit

The DWA Shut-Off kit is for M1240 Windrowers configured for both rotary disc and draper headers. This kit will enable the Operator to shut off the DWA draper in order to operate the windrower with a draper header.

MD #299704

Instructions are included in the kit.

6.2.6 Center-Link Lifter

This kit allows the center-link cylinder to be hydraulically positioned and connected to the header without leaving the operator's station.

MD #B6617

Instruction MD #214701 included in the bundle.

6.2.7 Swath Compressor

The MacDon Swath Compressor is a large, formed polyethylene sheet which is designed to mount to the underside of a MacDon M1 Series Windrower. The MacDon Swath Compressor is designed for use with D1XL and D1X Series Draper Headers cutting canola.

When lowered, the swath compressor helps prevent wind damage by shaping the windrow and anchoring it into the stubble behind the header using a smooth, gradual transition that helps prevent shelling in ripe conditions.

The swath compressor height can be adjusted and monitored with the Harvest Performance Tracker (HPT) display. Height can be adjusted for crop ripeness, yield, and the amount of compression required. The swath compressor will automatically lift up if the Operator stops or reverses the windrower.

Preferred height can be saved under a One-Touch-Return preset.

MD #B6441

Instructions are included with the kit.

6.3 Transport

6.3.1 Ballast

Ballast kits are for draper headers only. For operation on steep hills, additional ballast sets (beyond the recommendation in the table) may be installed.

Initial rear ballast package (MD #B6053): 1 unit (163 kg [360 lb.])

Additional rear ballast package (MD #B6054): 2 units (163 kg [360 lb.] each)

Installation instructions are included.

Table 6.3 Ballast

Header Type	Description	Installed Options	Base Kit	Additional Kits	Additional Float Springs
D125X	25 foot, single reel, double knife, timed	–	0	0	0
D130XL	30 foot, single reel, double knife, timed	Transport	1	0	0
D130XL	30 foot, single reel, double knife, timed	Transport + upper cross auger + vertical knives	1	0	MD #B6047
D135XL	35 foot, single reel, double knife, untimed	Base	1	1	0
D135XL	35 foot, single reel, double knife, untimed	Transport	1	1	MD #B6047
D135XL	35 foot, single reel, double knife, untimed	Transport + upper cross auger + vertical knives	1	2	MD #B6047
D135XL	35 foot, double reel, double knife, untimed	Base	1	1	0
D135XL	35 foot, double reel, double knife, untimed	Transport	1	1	MD #B6047
D135XL	35 foot, double reel, double knife, untimed	Transport + upper cross auger + vertical knives	1	2	MD #B6047
D140XL	40 foot, double reel, double knife, untimed	Base	1	1	0
D140XL	40 foot, double reel, double knife, untimed	Transport	1	1	MD #B6047
D140XL	40 foot, double reel, double knife, untimed	Transport + upper cross auger + vertical knives	1	2	MD #B6047
D145XL	45 foot, double reel, double knife, untimed	Base	1	1	MD #B6047
D145XL	45 foot, double reel, double knife, untimed	Transport	1	2	MD #B6047
D145XL	45 foot, double reel, double knife, untimed	Transport + upper cross auger + vertical knives	1	2	MD #B6106

6.3.2 Single Side Mud Caster Wheels

Single-sided mud caster wheels on an unsuspended assembly are designed to minimize wheel clogging in very heavy mud conditions.

MD #B6017

Instruction MD #214616 is included with the bundle.

6.3.3 Towing Harness

The towing harness is used together with the weight box (refer to [6.3.4 Weight Box, page 444](#)) when towing a D1XL or D1X Series Draper Header equipped with slow speed transport option behind the windrower.

MD #B6048 – Weight box harness only. Includes hitch pin and wiring for use with slow speed header transport option.

Instruction MD #147868 is included in the bundle.

6.3.4 Weight Box

A weight box installed onto the windrower header lift system is required to transport a header behind the windrower.

MD #B5238 – Weight box without harness

A towing harness is required to use the weight box. Refer to [6.3.3 Towing Harness, page 444](#) for more information.

Chapter 7: Troubleshooting

7.1 Engine Troubleshooting

Problem	Solution	Section
Symptom: Engine won't crank.		
Controls not in NEUTRAL	Move ground speed lever (GSL) to NEUTRAL.	<i>Starting the Engine, page 119</i>
Controls not in NEUTRAL	Move steering wheel to locked (centered) position.	<i>Starting the Engine, page 119</i>
Controls not in NEUTRAL	Disengage HEADER ENGAGE switch.	<i>3.2.1 Header Drive, page 39</i>
Symptom: Engine hard to start or will not start.		
NEUTRAL interlock misadjusted	Contact Dealer.	Contact Dealer
No fuel to engine	Fill empty fuel tank. Replace clogged filter.	<i>Filling Fuel Tank, page 115 and 5.11.1 Maintaining Fuel Filters, page 369</i>
Old fuel in tank	Drain tank. Refill with fresh fuel.	<i>5.15.2 Draining Fuel Tank, page 401</i>
Water, dirt, or air in fuel system	Drain, flush, fill, and prime system.	<i>Priming Fuel System, page 371</i>
Improper type of fuel	Use proper fuel for operating conditions.	<i>5.1.2 Fuel Specifications, page 294</i>
Crankcase oil too heavy	Use recommended oil.	<i>5.1.3 Lubricants, Fluids, and System Capacities, page 295</i>
Low battery output	Have battery tested. Check battery electrolyte level.	<i>5.14.1 Batteries, page 386</i>
Poor battery connection	Clean and tighten loose connections.	<i>5.14.1 Batteries, page 386</i>
Faulty starter	Contact Dealer.	Contact Dealer
Loose electrical connection at fuel pump	Ensure connector at pump is fully pushed in.	Contact Dealer
Wiring shorted, circuit breaker open	Check continuity of wiring and breaker (manual reset).	<i>Checking and Replacing Fuses, page 421</i>
ECM fuse (1 of 2) blown	Replace.	<i>Checking and Replacing Fuses, page 421</i>
ECM Ignition relay faulty	Replace.	<i>Checking and Replacing Fuses, page 421</i>
Faulty injectors	Contact Dealer.	Contact Dealer
Symptom: Engine knocks.		
Engine out of time	Contact Dealer.	Contact Dealer
Insufficient oil	Add oil.	<i>Adding Engine Oil, page 357</i>
Low or high coolant temperature	Contact Dealer.	Contact Dealer
Improper fuel	Use proper fuel.	<i>5.1.2 Fuel Specifications, page 294</i>

TROUBLESHOOTING

Problem	Solution	Section
Symptom: Low oil pressure.		
Low oil level	Add oil.	<i>Adding Engine Oil, page 357</i>
Improper type of oil	Drain and fill crankcase with proper oil.	<i>5.1.3 Lubricants, Fluids, and System Capacities, page 295</i>
Worn components	Contact Dealer.	Contact Dealer
Symptom: High oil consumption.		
Internal parts worn	Contact Dealer.	Contact Dealer
Crankcase oil too light	Use recommended oil.	<i>5.1.3 Lubricants, Fluids, and System Capacities, page 295</i>
Oil leaks	Check for leaks around gaskets, seals, and drain plugs.	<i>5.7.1 Checking Engine Oil Level, page 334</i>
Symptom: Engine runs irregularly or frequently stalls.		
Unsteady fuel supply	Change filter on fuel tank vent line. Replace clogged fuel filter.	<i>5.12.1 Removing and Installing the Fuel Tank Vent Filter, page 375 and 5.11.1 Maintaining Fuel Filters, page 369</i>
Water or dirt in fuel system	Drain, flush, and fill fuel system.	<i>5.1.3 Lubricants, Fluids, and System Capacities, page 295</i>
Low coolant temperature	Remove and check thermostat.	Contact Dealer
Air in fuel system	Contact Dealer.	Contact Dealer
Dirty or faulty injectors	Contact Dealer.	Contact Dealer
Symptom: Lack of power.		
Incorrect timing	Contact Dealer.	Contact Dealer
Engine oil viscosity too high	Use recommended oil.	<i>5.1.3 Lubricants, Fluids, and System Capacities, page 295</i>
Intake air restriction	Service air cleaner.	<i>Cleaning Primary Air Filter, page 361</i>
Clogged fuel filter	Replace primary fuel filter, and if necessary, replace secondary fuel filter.	<i>5.11.1 Maintaining Fuel Filters, page 369</i>
High back pressure	Clean out or replace exhaust canisters.	<i>5.10.7 Inspecting Exhaust System, page 365</i>
Improper type of fuel	Use proper fuel.	<i>5.1.2 Fuel Specifications, page 294</i>
High or low engine temperature	Remove and check thermostat.	Contact Dealer
Improper valve clearance	Contact Dealer.	Contact Dealer
Faulty injectors	Contact Dealer.	Contact Dealer
Symptom: Engine temperature is below normal.		
Defective thermostat	Remove and check thermostat.	Contact Dealer
Symptom: Warning alarm sounds.		
Engine overheated	Check thermostat.	Contact Dealer

TROUBLESHOOTING

Problem	Solution	Section
Engine overheated	Check coolant level.	<i>5.7.5 Checking Engine Coolant Level, page 341</i>
Low engine oil pressure	Check oil level.	<i>5.7.1 Checking Engine Oil Level, page 334</i>
Low charge oil pressure	Check oil level.	<i>5.7.3 Checking Hydraulic Oil, page 337</i>
Symptom: Engine overheats.		
Low coolant level	Fill reserve tank to proper level. Check system for leaks.	<i>Adding Coolant, page 381</i>
Water only for coolant	Replace with antifreeze.	<i>Adding Coolant, page 381</i>
Engine overloaded	Reduce ground speed.	<i>Driving Forward in Cab-Forward Mode, page 131</i>
Defective radiator cap	Replace cap.	<i>Inspecting Pressurized Coolant Tank Cap, page 310</i>
Dirty radiator screen	Clean screen.	<i>5.9.2 Cleaning Cooler Module, page 350</i>
Dirty radiator core	Clean radiator.	<i>5.9.2 Cleaning Cooler Module, page 350</i>
Cooling system dirty	Flush cooling system.	<i>5.13.1 Changing Engine Coolant, page 380</i>
Defective thermostat	Remove and check thermostat.	Contact Dealer
Defective temperature gauge or sender	Check coolant temperature with thermometer. Replace gauge if necessary.	Contact Dealer
Defective water pump	Contact Dealer.	Contact Dealer
Symptom: High fuel consumption.		
Clogged or dirty air cleaner	Service air cleaner.	<i>Cleaning Primary Air Filter, page 361</i>
Engine overloaded	Reduce ground speed.	<i>Driving Forward in Cab-Forward Mode, page 131</i>
Improper valve clearance	Contact Dealer.	Contact Dealer
Engine out of time	Contact Dealer.	Contact Dealer
Dirty injector nozzles	Contact Dealer.	Contact Dealer
Low engine temperature	Check thermostat.	Contact Dealer
Improper type of fuel	Use proper fuel.	<i>5.1.2 Fuel Specifications, page 294</i>
Symptom: Starter cranks slowly or will not operate.		
Low battery output	Check battery charge.	<i>Maintaining a Battery, page 386</i>
Loose or corroded battery connections	Clean and tighten loose connections.	<i>Maintaining a Battery, page 386</i>
Controls not in NEUTRAL	Move GSL to NEUTRAL.	<i>Starting the Engine, page 119</i>
Controls not in NEUTRAL	Move steering wheel to locked (centered) position.	<i>Driving in Reverse in Cab-Forward Mode, page 133</i>
Controls not in NEUTRAL	Disengage header.	<i>Engaging and Disengaging the Header, page 225</i>

TROUBLESHOOTING

Problem	Solution	Section
Relay not functioning	Check relay and wire connections.	<i>Checking and Replacing Fuses, page 421</i>
Main fuse defective/blown	Replace main fuse.	<i>Checking and Replacing Fuses, page 421</i>
Key power fuse blown	Replace.	<i>Checking and Replacing Fuses, page 421</i>
Key switch worn or terminals loose	Contact Dealer.	Contact Dealer
Switch at Interlock not closed or defective	Adjust switch or replace Contact your Dealer.	Contact Dealer
Crankcase oil too high viscosity	Use recommended oil.	<i>5.1.3 Lubricants, Fluids, and System Capacities, page 295</i>

7.2 Electrical Troubleshooting

Problem	Solution	Section
Symptom: Low voltage and/or the battery will not charge.		
Defective battery	Have battery tested.	<i>5.14.1 Batteries, page 386</i>
Loose or corroded connections	Clean and tighten battery connections.	<i>Maintaining a Battery, page 386</i>
Defective alternator belt	Replace worn belt.	<i>Replacing Engine Fan Drive Belt, page 403</i>
Alternator or voltage regulator not connected properly	Connect properly.	<i>5.14.1 Batteries, page 386</i>
Dirty or defective alternator, defective voltage regulator, or high resistance in circuit	Contact Dealer.	Contact Dealer
Symptom: Lights dim.		
High resistance in circuit or poor ground on lights	Check the wiring circuit for a break in a wire or a poor ground.	—
Symptom: Lights do not light.		
Burned out or defective light bulb	Replace light bulb.	<i>Replacing Headlight Bulb – Engine-Forward, page 412</i>
Burned out or defective light bulb	Replace light bulb.	<i>Replacing Bulbs in Standard Work Lights, page 411</i>
Burned out or defective light bulb	Replace light bulb.	<i>Replacing LED Lights – Deluxe Cab Only, page 414</i>
Burned out or defective light bulb	Replace light bulb.	<i>Replacing Bulbs in Red and Amber Lights, page 415</i>
Burned out or defective light bulb	Replace light bulb.	<i>Replacing Red Tail Lights, page 416</i>
Burned out or defective light bulb	Replace light bulb.	<i>Replacing Beacon Lights, page 416</i>
Burned out or defective light bulb	Replace light bulb.	<i>Replacing the Cabin Dome Bulb, page 417</i>
Broken wiring	Check wiring for broken wire or shorts.	—
Poor ground on lights	Clean and tighten ground wires.	—
Open or defective circuit breaker	Check circuit breaker.	<i>5.15.7 Accessing Circuit Breakers and Fuses, page 420</i>
Defective relay	Replace relay.	<i>Replacing Circuit Breakers and Relays, page 422</i>
Symptom: Wrong turn signal/indicator lights activated.		
Reversed wiring	Contact Dealer.	Contact Dealer
Symptom: No current to tab.		
Broken or disconnected wire	Contact Dealer.	Contact Dealer
Circuit breaker tripped	Breaker automatically resets.	—

7.3 Hydraulics Troubleshooting

Problem	Solution	Section
Symptom: Header or reel is not lifting.		
Appropriate solenoids not being energized by activating switch	Contact Dealer.	Contact Dealer
Symptom: Reel and/or conveyor is not turning.		
Flow controls adjusted too low	Toggle speed controls on Harvest Performance Tracker (HPT) display to increase flow.	<i>Conveyor Speed Adjustment Buttons, page 76 and Reel and Disc Speed Switch, page 73</i>
Flow controls adjusted too low	Toggle speed controls on Harvest Performance Tracker (HPT) display to increase flow.	<i>Conveyor Speed Adjustment Buttons, page 76 and Reel and Disc Speed Switch, page 73</i>
Appropriate solenoid on flow control block not being energized	Contact Dealer.	Contact Dealer
Relief pressure too low	Check/adjust/clean relief valve.	Contact Dealer
Symptom: Hydraulic oil high-temperature alarm activates.		
Hydraulic oil cooling system not working properly	Check/clean cooling box.	<i>5.9.2 Cleaning Cooler Module, page 350</i>

7.4 Header Drive Troubleshooting

Problem	Solution	Section
Symptom: Header drive is not engaging.		
OPERATOR PRESENCE switch not closed or faulty	Occupy operator's seat or replace switch. Contact your Dealer.	Contact Dealer
OPERATOR PRESENCE switch not closed or faulty	Occupy operator's seat or replace switch. Contact your Dealer.	Contact Dealer
Appropriate solenoid not being energized by activating switch	Contact Dealer.	Contact Dealer
Couplers not connected	Contact Dealer.	Contact Dealer
Faulty pump or flow controls	Contact Dealer.	Contact Dealer
Control solenoids disconnected	Contact Dealer.	Contact Dealer
Header ID not detected	Attach header or check wiring. Contact your Dealer.	Contact Dealer
Symptom: Header drive lacks power.		
Relief valve setting too low	Contact Dealer.	Contact Dealer
Header drive overload	Reduce ground speed.	—
Symptom: Warning alarm sounds.		
Header drive overload	Reduce ground speed.	—
Relief valve setting too low	Contact Dealer.	Contact Dealer

7.5 Traction Drive Troubleshooting

Problem	Solution	Section
Symptom: The warning alarm sounds and the low charge pressure warning appears on the Harvest Performance Tracker (HPT).		
Low hydraulic oil level	Stop engine, and add oil to hydraulic system.	5.7.3 Checking Hydraulic Oil, page 337
Low hydraulic pressure	Contact Dealer.	Contact Dealer
Faulty sender	Contact Dealer.	Contact Dealer
Symptom: Wheels lack necessary ability to pull on a grade or when pulling out of a ditch.		
Internal pump or motor damage	Contact Dealer.	Contact Dealer
Insufficient torque at drive wheels	Maintain engine rpm, decrease GSL setting.	—
Loose or worn controls	Check controls.	Contact Dealer
Brakes binding or not releasing fully	Check charge pressure.	Contact Dealer
Relief valve in tandem pump dirty or damaged	Replace relief valve.	Contact Dealer
Symptom: With the steering wheel centered, one wheel pulls more than the other wheel.		
Leakage at pump or motor	Contact Dealer.	Contact Dealer
Binding or interference with controls under cab	Contact Dealer.	Contact Dealer
Faulty relief valve	Repair or replace valve Contact Dealer.	Contact Dealer
Symptom: Both wheels will not pull in forward or in reverse.		
Loose hardware on pump controls	Repair or tighten.	Contact Dealer
Brakes binding or not releasing fully	Check charge pressure.	Contact Dealer
Low oil level and low charge pressure	Check oil reservoir level.	5.7.3 Checking Hydraulic Oil, page 337
Wheel drives disengaged	Engage wheel drives.	Contact Dealer
Servo input loose	Check servo.	Contact Dealer
Failed pump	Contact Dealer.	Contact Dealer
Symptom: One wheel will not pull in forward or in reverse.		
Broken pump arm or shaft	Contact Dealer.	Contact Dealer
Steering controls worn or defective	Check GSL and steering for loose, worn or damaged ball joints and connecting rods.	Contact Dealer
High pressure relief valve stuck open, damaged seat	Contact Dealer.	Contact Dealer
Brakes binding or not releasing fully	Check charge pressure.	Contact Dealer
Failed pump, motor or final drive	Contact Dealer.	Contact Dealer
Symptom: Excessive noise from the drive system.		
Mechanical interference in steering or ground speed linkage	Remove interference.	Contact Dealer

TROUBLESHOOTING

Problem	Solution	Section
Brakes binding or not releasing fully	Check charge pressure.	Contact Dealer
Faulty pump or motor	Contact Dealer.	Contact Dealer
Air in system	Check lines for leakage.	—
Hydraulic line clamps loose	Tighten clamps.	—
Ball joints are worn	Replace worn parts.	—
Symptom: The hydraulic oil filter leaks at a seal.		
Not properly tightened	Tighten filter element.	<i>Installing Return Oil Filter, page 331</i> or <i>Installing Charge Filter, page 333</i>
Damaged seal or threads	Replace filter or filter head.	<i>Removing Return Oil Filter, page 330</i> or <i>Removing Charge Filter, page 332</i>

7.6 Steering and Ground Speed Control Troubleshooting

Problem	Solution	Section
Symptom: The machine will not steer straight.		
Linkage worn or loose	Adjust steering chain tension. Replace worn parts. Adjust linkage.	—
Symptom: The machine moves on flat ground with controls set to neutral.		
Neutral interlock misadjusted	Contact Dealer.	—
Parking brake not functioning	Contact Dealer.	—
Ground speed lever (GSL) servo misadjusted	Contact Dealer.	—
GSL cable misadjusted	Contact Dealer.	—
Symptom: Steering wheel will not lock with the GSL set to PARK.		
Transmission interlock misadjusted	Contact Dealer.	—
Faulty GSL neutral switch	Contact Dealer.	—
Interlock springs not pulling interlock closed	Replace or reattach springs.	—
Faulty switch on PARK	Replace switch or adjust.	—
Symptom: Insufficient road speed.		
Ground speed limit is too low	Increase limit.	<i>Adjusting Ground Speed Limit, page 130</i>
Symptom: Maximum ground speed is too slow.		
Servo not adjusted properly	Contact Dealer.	—
Fault with wheel motor control	Contact Dealer.	—
GSL position sensor not calibrated or damaged	Contact Dealer.	—
Maximum speed limit is set at 16 km/hr (10 mph)	Increase speed limit.	<i>Adjusting Ground Speed Limit, page 130</i>
Symptom: Steering is too stiff or too loose.		
Steering chain tension is out of adjustment	Adjust steering chain tension.	—
Ball joints or steering linkage pivot stiff	Replace or repair.	—

7.7 Cab Air Troubleshooting

Problem	Solution	Section
Symptom: The blower fan will not run.		
Burned out motor	Contact Dealer.	—
Burned out switch	Contact Dealer.	—
Motor shaft tight or bearings worn	Contact Dealer.	—
Faulty wiring—loose or broken	Contact Dealer.	—
Blower rotors in contact with housing	Contact Dealer.	—
Burned out motor	—	—
Symptom: The blower fan is operating, but air doesn't blow into the cab.		
Dirty fresh air filter	Clean fresh air filter.	<i>Inspecting and Cleaning Fresh Air Intake Filter Element, page 345</i>
Dirty recirculating air filter	Clean return air filter.	<i>5.9.1 Servicing Return Air Filter, page 349</i>
Evaporator clogged	Clean evaporator.	<i>Cleaning Air Conditioning Evaporator Core, page 398</i>
Air flow passage blocked	Remove blockage.	—
Symptom: Heater is not heating.		
Heater shut-off valve at engine closed	Open valve.	<i>3.10.1 Heater Shut-Off Valve, page 59</i>
Defective thermostat in engine water outlet manifold	Replace thermostat.	Contact Dealer.
Heater temperature control defective	Replace control.	Contact Dealer.
No thermostat in engine water outlet manifold	Install thermostat.	Contact Dealer.
Symptom: Air louvers emitting odor.		
Plugged drainage hose	Blow out hose with compressed air.	—
Dirty filters	Clean filters.	Contact Dealer.
Symptom: Air conditioning is not cooling.		
Low refrigerant level	Add refrigerant.	Contact Dealer.
Clutch coil burned out or disconnected	Contact Dealer.	—
Blower motor disconnected or burned out	Contact Dealer.	—
Switch contacts in thermostat burned excessively, or sensing element defective	Replace thermostat.	Contact Dealer.
Compressor partially or completely seized	Remove compressor for service or replacement.	Contact Dealer.
Condenser fins plugged	Clean condenser.	<i>Cleaning Left Cooling Module, page 350</i>

TROUBLESHOOTING

Problem	Solution	Section
Loose or broken compressor drive belt	Replace drive belt and/or tighten to specifications.	<i>Tensioning Air Conditioner Compressor Belts, page 404 and Replacing Air Conditioner Compressor Belts, page 405</i>
Dirty filters	Clean fresh air and recirculation filters.	<i>5.9.1 Servicing Return Air Filter, page 349</i>
Broken or disconnected electrical wire	Check all terminals for loose connections; check wiring for hidden breaks.	—
Broken or disconnected ground wire	Check ground wire to see if loose, broken, or disconnected.	—
Expansion valve stuck in open or closed position	Contact Dealer.	—
Broken refrigerant line	Contact Dealer.	—
Leak in system	Contact Dealer.	—
Compressor shaft seal leaking	Contact Dealer.	—
Clogged screen in receiver-drier; plugged hose or coil	Contact Dealer.	—
Symptom: Air conditioning is not producing sufficient cooling (meaning that air temperature in the windrower cab, measured at the louvered vent, can be maintained at 14°C [57°F] below ambient air temperature)		
Compressor clutch slipping	Remove clutch assembly for service or replacement.	Contact Dealer.
Thermostat defective or improperly adjusted	Replace thermostat.	Contact Dealer.
Clogged air filters	Remove air filters, and clean or replace as necessary.	<i>5.9.1 Servicing Return Air Filter, page 349</i>
Heater circuit is open	Lower temperature control in cab, and close valve on engine.	<i>3.10.3 Climate Controls, page 60 and 3.10.1 Heater Shut-Off Valve, page 59</i>
Insufficient air circulation over condenser coil; fins clogged with dirt or insects	Clean condenser.	<i>Cleaning Left Cooling Module, page 350</i>
Evaporator fins clogged	Clean evaporator fins (under cab floor).	<i>Cleaning Air Conditioning Evaporator Core, page 398</i>
Refrigerant low	Contact Dealer.	—
Clogged expansion valve	Contact Dealer.	—
Clogged receiver-drier	Contact Dealer.	—
Excessive moisture in system	Contact Dealer.	—
Air in system	Contact Dealer.	—
Blower motor sluggish in operation	Contact Dealer.	—
Symptom: Air conditioning cools intermittently.		
Unit icing up due to thermostat adjusted too low	Adjust thermostat.	Contact Dealer.

TROUBLESHOOTING

Problem	Solution	Section
Unit icing up due to excessive moisture in system	Contact Dealer.	—
Unit icing up due to incorrect super-heat adjustment in the expansion valve	Contact Dealer.	—
Thermostat defective	Contact Dealer.	—
Defective blower switch or blower motor	Contact Dealer.	—
Partially open, improper ground or loose connection in compressor clutch coil	Contact Dealer.	—
Compressor clutch slipping	Contact Dealer.	—
Symptom: Air conditioning system too noisy.		
Defective winding or improper connection in compressor clutch coil or relay	Contact Dealer.	—
Excessive charge in system	Contact Dealer.	—
Low charge in system	Contact Dealer.	—
Excessive moisture in system	Contact Dealer.	—
Loose or excessively worn drive belt	Tighten or replace as required.	<i>Tensioning Air Conditioner Compressor Belts, page 404 and Replacing Air Conditioner Compressor Belts, page 405</i>
Noisy clutch	Remove clutch for service or replacement as required.	Contact Dealer.
Noisy compressor	Check mountings and repair. Remove compressor for service or replacement.	Contact Dealer.
Compressor oil level low	Add SP-15 PAG refrigerant oil.	Contact Dealer.
Blower fan noisy due to excessive wear	Remove blower motor for service or replacement as necessary.	Contact Dealer.
Symptom: Cab windows fog up.		
High humidity	Run A/C to dehumidify air and heater to control temperature.	<i>3.10.3 Climate Controls, page 60</i>

7.8 Operator's Station Troubleshooting

Problem	Solution	Section
Rough ride.		
Seat suspension not adjusted for operator's weight	Adjust seat suspension.	<i>3.3.3 Suspension and Height, page 41</i>
High air pressure in tires	Deflate to proper pressure.	<i>5.7.4 Checking Tire Pressures, page 338</i>
Cab suspension too stiff	Adjust suspension.	Contact Dealer.

Chapter 8: Reference

8.1 Torque Specifications

The following tables provide correct torque values for various bolts, cap screws, and hydraulic fittings.

- Tighten all bolts to torque values specified in charts (unless otherwise noted throughout this manual).
- Replace hardware with same strength and grade of bolt.
- Use torque value tables as a guide and periodically check tightness of bolts.
- Understand torque categories for bolts and cap screws by using their identifying head markings.

Jam nuts

When applying torque to finished jam nuts, multiply the torque applied to regular nuts by $f=0.65$.

Self-tapping screws

Standard torque is to be used (**NOT** to be used on critical or structurally important joints).

8.1.1 Metric Bolt Specifications

Table 8.1 Metric Class 8.8 Bolts and Class 9 Free Spinning Nut

Nominal Size (A)	Torque (Nm)		Torque (lbf·ft) (*lbf·in)	
	Min.	Max.	Min.	Max.
3-0.5	1.4	1.6	*13	*14
3.5-0.6	2.2	2.5	*20	*22
4-0.7	3.3	3.7	*29	*32
5-0.8	6.7	7.4	*59	*66
6-1.0	11.4	12.6	*101	*112
8-1.25	28	30	20	23
10-1.5	55	60	40	45
12-1.75	95	105	70	78
14-2.0	152	168	113	124
16-2.0	236	261	175	193
20-2.5	460	509	341	377
24-3.0	796	879	589	651

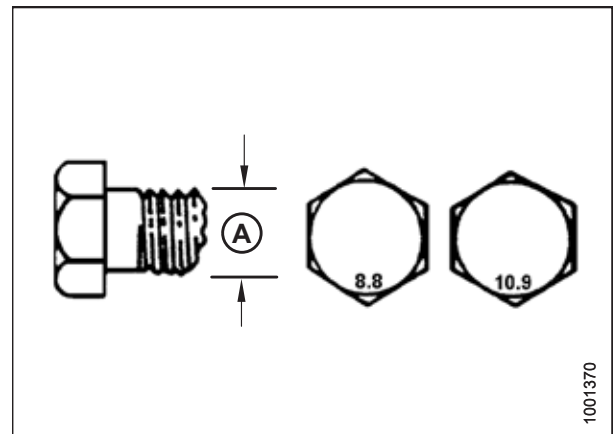

Figure 8.1: Bolt Grades

1001370

REFERENCE

Table 8.2 Metric Class 8.8 Bolts and Class 9 Distorted Thread Nut

Nominal Size (A)	Torque (Nm)		Torque (lbf-ft) (*lbf-in)	
	Min.	Max.	Min.	Max.
3-0.5	1	1.1	*9	*10
3.5-0.6	1.5	1.7	*14	*15
4-0.7	2.3	2.5	*20	*22
5-0.8	4.5	5	*40	*45
6-1.0	7.7	8.6	*69	*76
8-1.25	18.8	20.8	*167	*185
10-1.5	37	41	28	30
12-1.75	65	72	48	53
14-2.0	104	115	77	85
16-2.0	161	178	119	132
20-2.5	314	347	233	257
24-3.0	543	600	402	444

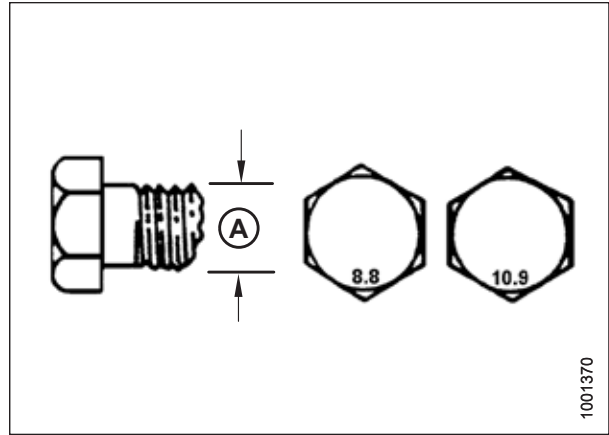

Figure 8.2: Bolt Grades

Table 8.3 Metric Class 10.9 Bolts and Class 10 Free Spinning Nut

Nominal Size (A)	Torque (Nm)		Torque (lbf-ft) (*lbf-in)	
	Min.	Max.	Min.	Max.
3-0.5	1.8	2	*18	*19
3.5-0.6	2.8	3.1	*27	*30
4-0.7	4.2	4.6	*41	*45
5-0.8	8.4	9.3	*82	*91
6-1.0	14.3	15.8	*140	*154
8-1.25	38	42	28	31
10-1.5	75	83	56	62
12-1.75	132	145	97	108
14-2.0	210	232	156	172
16-2.0	326	360	242	267
20-2.5	637	704	472	521
24-3.0	1101	1217	815	901

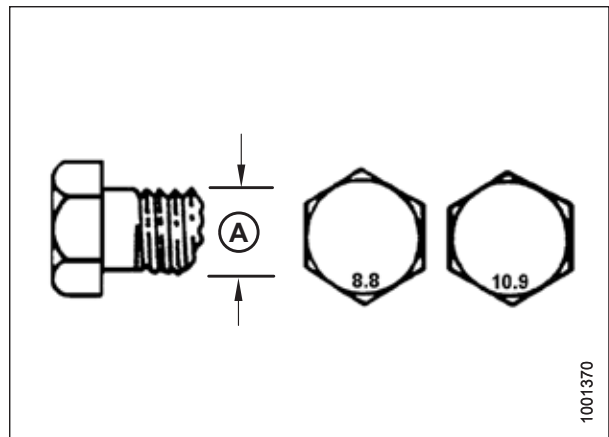

Figure 8.3: Bolt Grades

REFERENCE

Table 8.4 Metric Class 10.9 Bolts and Class 10 Distorted Thread Nut

Nominal Size (A)	Torque (Nm)		Torque (lbf-ft) (*lbf-in)	
	Min.	Max.	Min.	Max.
3-0.5	1.3	1.5	*12	*13
3.5-0.6	2.1	2.3	*19	*21
4-0.7	3.1	3.4	*28	*31
5-0.8	6.3	7	*56	*62
6-1.0	10.7	11.8	*95	*105
8-1.25	26	29	19	21
10-1.5	51	57	38	42
12-1.75	90	99	66	73
14-2.0	143	158	106	117
16-2.0	222	246	165	182
20-2.5	434	480	322	356
24-3.0	750	829	556	614

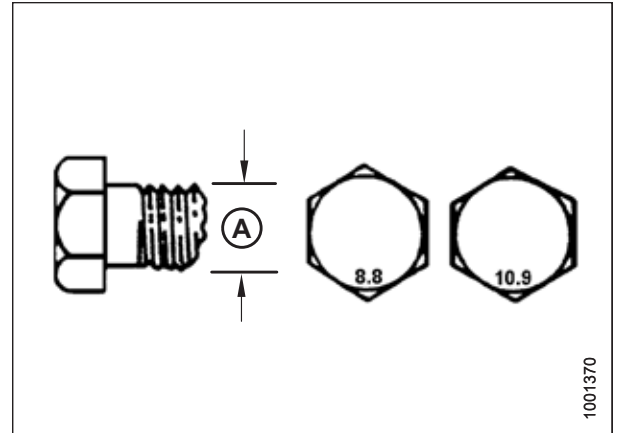

Figure 8.4: Bolt Grades

8.1.2 Metric Bolt Specifications Bolting into Cast Aluminum

Table 8.5 Metric Bolt Bolting into Cast Aluminum

Nominal Size (A)	Bolt Torque			
	8.8 (Cast Aluminum)		10.9 (Cast Aluminum)	
	Nm	lbf-ft	Nm	lbf-ft
M3	-	-	-	1
M4	-	-	4	2.6
M5	-	-	8	5.5
M6	9	6	12	9
M8	20	14	28	20
M10	40	28	55	40
M12	70	52	100	73
M14	-	-	-	-
M16	-	-	-	-

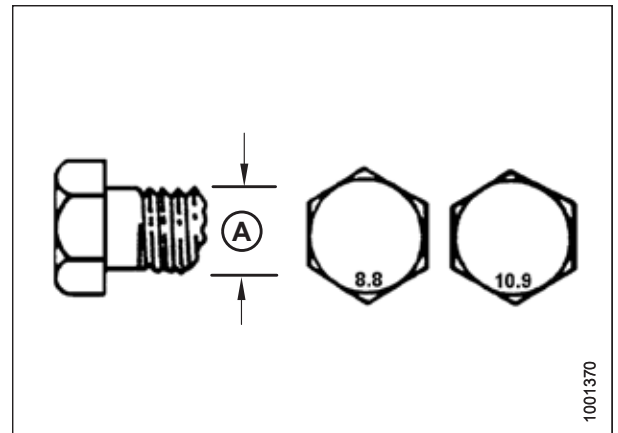

Figure 8.5: Bolt Grades

8.1.3 O-Ring Boss Hydraulic Fittings – Adjustable

1. Inspect O-ring (A) and seat (B) for dirt or obvious defects.
2. Back off lock nut (C) as far as possible. Ensure that washer (D) is loose and is pushed toward lock nut (C) as far as possible.
3. Check that O-ring (A) is **NOT** on threads and adjust if necessary.
4. Apply hydraulic system oil to O-ring (A).

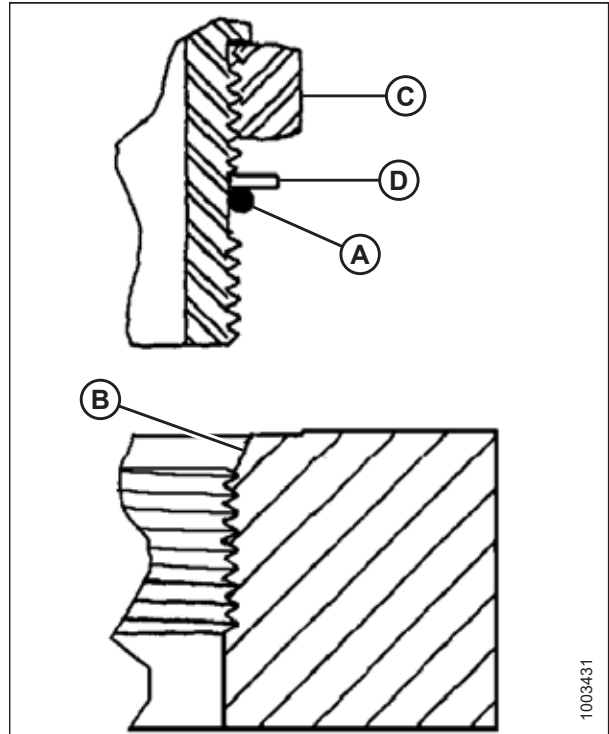

Figure 8.6: Hydraulic Fitting

5. Install fitting (B) into port until backup washer (D) and O-ring (A) contact part face (E).
6. Position angle fittings by unscrewing no more than one turn.
7. Turn lock nut (C) down to washer (D) and tighten to torque shown. Use two wrenches, one on fitting (B) and other on lock nut (C).
8. Check final condition of fitting.

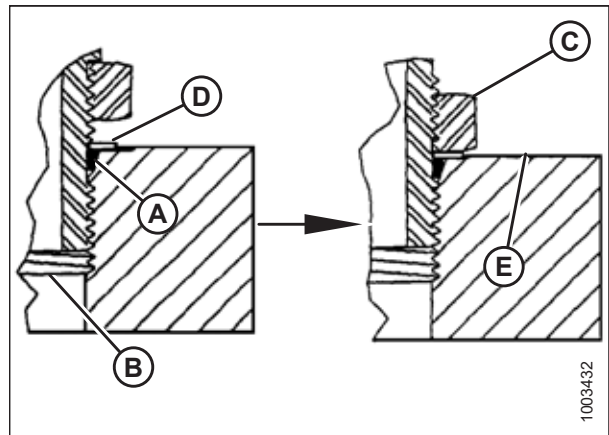

Figure 8.7: Hydraulic Fitting

Table 8.6 O-Ring Boss (ORB) Hydraulic Fittings – Adjustable

SAE Dash Size	Thread Size (in.)	Torque Value ²⁴	
		Nm	lbf·ft (*lbf·in)
-2	5/16–24	6–7	*53–62
-3	3/8–24	12–13	*106–115
-4	7/16–20	19–21	14–15

24. Torque values shown are based on lubricated connections as in reassembly.

REFERENCE

Table 8.6 O-Ring Boss (ORB) Hydraulic Fittings – Adjustable (continued)

SAE Dash Size	Thread Size (in.)	Torque Value ²⁵	
		Nm	lbf·ft (*lbf·in)
-5	1/2-20	21-33	15-24
-6	9/16-18	26-29	19-21
-8	3/4-16	46-50	34-37
-10	7/8-14	75-82	55-60
-12	1 1/16-12	120-132	88-97
-14	1 3/8-12	153-168	113-124
-16	1 5/16-12	176-193	130-142
-20	1 5/8-12	221-243	163-179
-24	1 7/8-12	270-298	199-220
-32	2 1/2-12	332-365	245-269

25. Torque values shown are based on lubricated connections as in reassembly.

REFERENCE

8.1.4 O-Ring Boss Hydraulic Fittings – Non-Adjustable

1. Inspect O-ring (A) and seat (B) for dirt or obvious defects.
2. Check that O-ring (A) is **NOT** on threads and adjust if necessary.
3. Apply hydraulic system oil to O-ring.
4. Install fitting (C) into port until fitting is hand-tight.
5. Torque fitting (C) according to values in Table 8.7, page 464.
6. Check final condition of fitting.

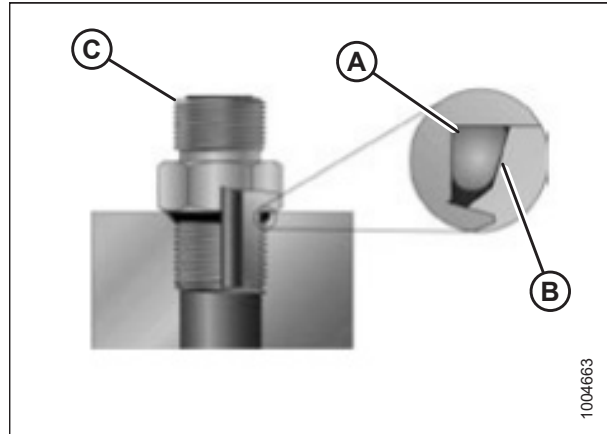

Figure 8.8: Hydraulic Fitting

Table 8.7 O-Ring Boss (ORB) Hydraulic Fittings – Non-Adjustable

SAE Dash Size	Thread Size (in.)	Torque Value ²⁶	
		Nm	lbf-ft (*lbf-in)
-2	5/16-24	6-7	*53-62
-3	3/8-24	12-13	*106-115
-4	7/16-20	19-21	14-15
-5	1/2-20	21-33	15-24
-6	9/16-18	26-29	19-21
-8	3/4-16	46-50	34-37
-10	7/8-14	75-82	55-60
-12	1 1/16-12	120-132	88-97
-14	1 3/8-12	153-168	113-124
-16	1 5/16-12	176-193	130-142
-20	1 5/8-12	221-243	163-179
-24	1 7/8-12	270-298	199-220
-32	2 1/2-12	332-365	245-269

26. Torque values shown are based on lubricated connections as in reassembly.

8.1.5 O-Ring Face Seal Hydraulic Fittings

1. Check components to ensure that sealing surfaces and fitting threads are free of burrs, nicks, scratches, or any foreign material.



Figure 8.9: Hydraulic Fitting

2. Apply hydraulic system oil to O-ring (B).
3. Align tube or hose assembly so that flat face of sleeve (A) or (C) comes in full contact with O-ring (B).
4. Thread tube or hose nut (D) until hand-tight. The nut should turn freely until it is bottomed out.
5. Torque fittings according to values in Table 8.8, page 465.

NOTE:

If applicable, hold hex on fitting body (E) to prevent rotation of fitting body and hose when tightening fitting nut (D).

6. Use three wrenches when assembling unions or joining two hoses together.
7. Check final condition of fitting.

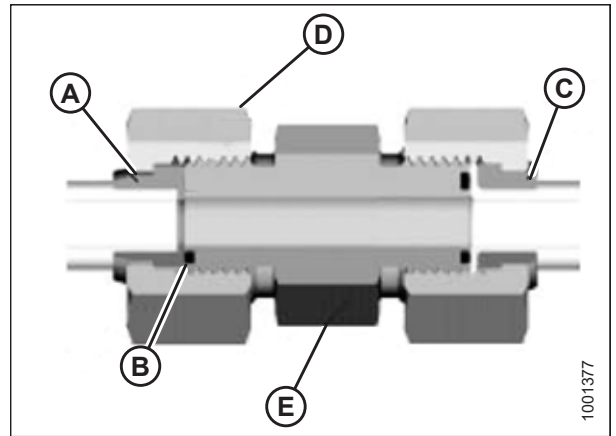

Figure 8.10: Hydraulic Fitting

Table 8.8 O-Ring Face Seal (ORFS) Hydraulic Fittings

SAE Dash Size	Thread Size (in.)	Tube O.D. (in.)	Torque Value ²⁷	
			Nm	lbf-ft
-3	Note ²⁸	3/16	–	–
-4	9/16	1/4	25–28	18–21
-5	Note ²⁸	5/16	–	–
-6	11/16	3/8	40–44	29–32
-8	13/16	1/2	55–61	41–45
-10	1	5/8	80–88	59–65
-12	1 3/16	3/4	115–127	85–94
-14	Note ²⁸	7/8	–	–

27. Torque values and angles shown are based on lubricated connection as in reassembly.

28. O-ring face seal type end not defined for this tube size.

REFERENCE

Table 8.8 O-Ring Face Seal (ORFS) Hydraulic Fittings (continued)

SAE Dash Size	Thread Size (in.)	Tube O.D. (in.)	Torque Value ²⁹	
			Nm	lbf-ft
-16	1 7/16	1	150–165	111–122
-20	1 11/16	1 1/4	205–226	151–167
-24	1–2	1 1/2	315–347	232–256
-32	2 1/2	2	510–561	376–414

8.1.6 Tapered Pipe Thread Fittings

Assemble pipe fittings as follows:

1. Check components to ensure that fitting and port threads are free of burrs, nicks, scratches, or any form of contamination.
2. Apply pipe thread sealant (paste type) to external pipe threads.
3. Thread fitting into port until hand-tight.
4. Torque connector to appropriate torque angle. The turns from finger tight (TFFT) and flats from finger tight (FFFT) values are shown in Table 8.9, page 466. Make sure that tube end of a shaped connector (typically 45° or 90°) is aligned to receive incoming tube or hose assembly. Always finish alignment of fitting in tightening direction. Never back off (loosen) pipe threaded connectors to achieve alignment.
5. Clean all residue and any excess thread conditioner with appropriate cleaner.
6. Assess final condition of fitting. Pay special attention to possibility of cracks to port opening.
7. Mark final position of fitting. If a fitting leaks, disassemble fitting and check for damage.

NOTE:

Overtorque failure of fittings may not be evident until fittings are disassembled.

Table 8.9 Hydraulic Fitting Pipe Thread

Tapered Pipe Thread Size	Recommended TFFT	Recommended FFFT
1/8–27	2–3	12–18
1/4–18	2–3	12–18
3/8–18	2–3	12–18
1/2–14	2–3	12–18
3/4–14	1.5–2.5	12–18
1–11 1/2	1.5–2.5	9–15
1 1/4–11 1/2	1.5–2.5	9–15
1 1/2–11 1/2	1.5–2.5	9–15
2–11 1/2	1.5–2.5	9–15

29. Torque values and angles shown are based on lubricated connection as in reassembly.

8.2 Conversion Chart

Table 8.10 Conversion Chart

Quantity	SI Units (Metric)		Factor	US Customary Units (Standard)	
	Unit Name	Abbreviation		Unit Name	Abbreviation
Area	hectare	ha	$\times 2.4710 =$	acre	acres
Flow	liters per minute	L/min	$\times 0.2642 =$	US gallons per minute	gpm
Force	Newton	N	$\times 0.2248 =$	pound force	lbf
Length	millimeter	mm	$\times 0.0394 =$	inch	in.
Length	meter	m	$\times 3.2808 =$	foot	ft.
Power	kilowatt	kW	$\times 1.341 =$	horsepower	hp
Pressure	kilopascal	kPa	$\times 0.145 =$	pounds per square inch	psi
Pressure	megapascal	MPa	$\times 145.038 =$	pounds per square inch	psi
Pressure	bar (Non-SI)	bar	$\times 14.5038 =$	pounds per square inch	psi
Torque	Newton meter	Nm	$\times 0.7376 =$	pound feet or foot pounds	lbf-ft
Torque	Newton meter	Nm	$\times 8.8507 =$	pound inches or inch pounds	lbf-in
Temperature	degrees Celsius	°C	$(^{\circ}\text{C} \times 1.8) + 32 =$	degrees Fahrenheit	°F
Velocity	meters per minute	m/min	$\times 3.2808 =$	feet per minute	ft/min
Velocity	meters per second	m/s	$\times 3.2808 =$	feet per second	ft/s
Velocity	kilometers per hour	km/h	$\times 0.6214 =$	miles per hour	mph
Volume	liter	L	$\times 0.2642 =$	US gallon	US gal
Volume	milliliter	mL	$\times 0.0338 =$	ounce	oz.
Volume	cubic centimeter	cm ³ or cc	$\times 0.061 =$	cubic inch	in. ³
Weight	kilogram	kg	$\times 2.2046 =$	pound	lb.

8.3 Windrower Fault Codes

The Harvest Performance Tracker (HPT) displays the windrower fault codes as a sequence of three numbers (AAA.BBBBBB.CC). The sequence is defined as follows:

- AAA = The Source Address (SA) defines which module generated the fault.
- BBBBBB = The SPN is the description of the unique fault value.
- CC = The FMI indicated the fault's level of severity.

Source address (SA) numbers refer to the following locations:

- 23: Harvest Performance Tracker (HPT) display
- 25: HVAC box
- 104: Master controller and connected extension modules
- 176: Roof relay module
- 178: Chassis relay module
- 190: Console and ground speed lever (GSL)

REFERENCE

Fault Codes			Telltale	Short Description	Full Fault Description	Recommended Fix/Check Message
SA	SPN	FMI				
23	521489	1	Electrical System	Master Module Offline	CAN 1 Offline	Check Module connectors; if OK, Contact Dealer.
23	521489	2	Electrical System	Master Module Offline	CAN 2 Offline	Check Module connectors; if OK, Contact Dealer.
23	521489	3	Electrical System	Master Module Offline	CAN 1 & 2 Offline	Check Module connectors; if OK, Contact Dealer.
23	521489	4	Electrical System	Master Module Offline	CAN 3 Offline	Check Module connectors; if OK, Contact Dealer.
23	521489	5	Electrical System	Master Module Offline	CAN 1 & 3 Offline	Check Module connectors; if OK, Contact Dealer.
23	521489	6	Electrical System	Master Module Offline	CAN 2 & 3 Offline	Check Module connectors; if OK, Contact Dealer.
23	521489	7	Electrical System	Master Module Offline	CAN 1 & 2 & 3 Offline	Check Module connectors and Module fuse; if OK, Contact Dealer.
23	521490	1	Electrical System	Ext. Module Offline	Firewall Extension Module Offline	Check Module connectors and Module fuse; if OK, Contact Dealer.
23	521491	1	Electrical System	Ext. Module Offline	Chassis Extension Module Offline	Check Module connectors and Module fuse; if OK, Contact Dealer.
23	521492	1	Electrical System	Display Offline	CAN 1 Offline	Check Module connectors; if OK, Contact Dealer.
23	521492	2	Electrical System	Display Offline	CAN 2 Offline	Check Module connectors; if OK, Contact Dealer.
23	521492	3	Electrical System	Display Offline	CAN 1 & 2 Offline	Check Module connectors; if OK, Contact Dealer.
23	521493	1	Electrical System	Relay Module Offline	Roof Relay Module Offline	Check Module connectors and Module fuse; if OK, Contact Dealer.
23	521494	1	Electrical System	Relay Module Offline	Chassis Relay Module Offline	Check Module connectors and Module fuse; if OK, Contact Dealer.
23	521495	1	Electrical System	Console Offline	Console Offline	Check Module connectors and Module fuse; if OK, Contact Dealer.
23	521496	1	Electrical System	HVAC ECU Offline	HVAC ECU Offline	Check Module connectors and Module fuse; if OK, Contact Dealer.

REFERENCE

Fault Codes		Telltale	Short Description	Full Fault Description	Recommended Fix/Check Message	
SA	SPN					FMI
23	521497	1	Electrical System	Engine ECM Offline	Engine Control Module Offline	First check if cooling module door is open or cooling module door sensor is defective. If not then check engine control module connectors and module fuse ; if OK, Contact Dealer.
23	521498	1	Electrical System	CAN 1 Offline	CAN 1 Offline	Check CAN Harnessing; if OK, Contact Dealer.
23	521499	1	Electrical System	CAN 2 Offline	CAN 2 Offline	Windrower lighting and HVAC will not be operational. Check CAN Harnessing; if OK, Contact Dealer.
23	521500	1	Electrical System	CAN 3 Offline	CAN 3 Offline	Check CAN Harnessing; if OK, Contact Dealer.
23	521515	1	Windrower	Water in fuel	Water in fuel detected	Drain fuel filter immediately.
25	168	1	Electrical System	HVAC	Low voltage - Below normal, most severe	Check HVAC power supply. Contact Dealer.
25	520193	5	Electrical System	HVAC	Clutch low amps - Current below normal	Inspect A/C clutch wiring for damage. Contact Dealer.
25	520193	6	Electrical System	HVAC	Clutch high amps - Current above normal	Inspect A/C clutch wiring for damage. Contact Dealer.
25	520194	3	Electrical System	HVAC	Evaporator temp open circuit - Voltage above normal	Check temperature sensor and wiring at the evaporator. Contact Dealer.
25	520194	4	Electrical System	HVAC	Evaporator temp shorted - Voltage below normal	Check temperature sensor and wiring at the evaporator. Contact Dealer.
25	170	3	Electrical System	HVAC	Cab temp open circuit - Voltage above normal	Inspect cab temperature and wiring. Contact Dealer.
25	170	4	Electrical System	HVAC	Cab temp shorted - Voltage below normal	Inspect cab temperature and wiring. Contact Dealer.
25	442	3	Electrical System	HVAC	Duct temp open circuit - Voltage above normal	Check HVAC duct temperature sensor wiring. Contact Dealer.

REFERENCE

Fault Codes			Telltale	Short Description	Full Fault Description	Recommended Fix/Check Message
SA	SPN	FMI				
25	442	4	Electrical System	HVAC	Duct temp shorted - Voltage below normal	Check HVAC duct temperature sensor wiring. Contact Dealer.
104	111	1	Windrower	Engine Coolant Low	Below Normal Most Severe	Coolant Level - Data Valid But Below Normal Operational Range.
104	111	17	Windrower	Engine Coolant Low	Below Normal Least Severe	Coolant Level - Data Valid But Below Normal Operating Range.
104	521000	3	Electrical System	Fuel Level Sender	Low Alarm	Sensor voltage below 0.5 V. Check sensor power supply. Replace sensor if necessary.
104	521000	4	Electrical System	Fuel Level Sender	High Alarm	Sensor voltage above 4.5 V. Check for wiring damage. Replace sensor if necessary.
104	521000	5	Electrical System	Fuel Level Sender	Low Error	Sensor voltage below 0.5 V. Check sensor power supply. Replace sensor if necessary.
104	521000	6	Electrical System	Fuel Level Sender	High Error	Sensor voltage above 4.5 V. Check for wiring damage. Replace sensor if necessary.
104	521000	8	Electrical System	Fuel Level Sender	Vref Error	Reference voltage error. Check sensor wiring for damage.
104	521003	3	Electrical System	GSL Position	Low Alarm	Sensor voltage below 0.5 V. Check sensor power supply. Contact dealer to adjust and re-calibrate or replace sensor if necessary.
104	521003	4	Electrical System	GSL Position	High Alarm	Sensor voltage above 4.5 V. Check for wiring damage. Contact dealer to adjust and re-calibrate or replace sensor if necessary.
104	521003	5	Electrical System	GSL Position	Low Error	Sensor voltage below 0.5 V. Check sensor power supply. Contact dealer to adjust and re-calibrate or replace sensor if necessary.
104	521003	6	Electrical System	GSL Position	High Error	Sensor voltage above 4.5 V. Check for wiring damage. Contact Dealer to adjust and re-calibrate or replace sensor if necessary.
104	521003	8	Electrical System	GSL Position	Vref Error	Reference voltage error. Check sensor wiring for damage.
104	521006	5	Electrical System	Hyd Oil Temp Sensor	Low Error	Sensor voltage below 50 mV. Check sensor power supply. Replace sensor if necessary.

REFERENCE

Fault Codes			Telltale	Short Description	Full Fault Description	Recommended Fix/Check Message
SA	SPN	FMI				
104	521006	6	Electrical System	Hyd Oil Temp Sensor	High Error	Sensor voltage above 1300 mV. Check for wiring damage. Replace sensor if necessary.
104	521006	8	Electrical System	Hyd Oil Temp Sensor	Vref Error	Reference voltage error. Check sensor wiring for damage.
104	521383	15	Windrower	Hydraulic Oil Hot	Above Normal Least Severe	Clean cooler cores with compressed air. If condition persists with clean cores, contact dealer.
104	521383	0	Windrower	Hyd Oil Very Hot	Above Normal Most Severe	Clean cooler cores with compressed air. If condition persists with clean cores, contact dealer. Continued operation may lead to machine damage.
104	521387	0	Windrower	Oil Charge Press High	Above Normal Most Severe	Charge pressure relief valve may be misadjusted or damaged. Contact dealer.
104	521387	17	Windrower	Oil Charge Press Low	Below Normal Least Severe	Charge pressure relief valve may be misadjusted or damaged. Contact dealer.
104	521387	1	Windrower	Oil Charge Press Low	Below Normal Most Severe	Shut down engine. Charge pressure relief valve may be misadjusted or damaged. Contact Dealer.
104	521021	3	Electrical System	Reel Height	Low Alarm	Sensor voltage below 0.5 V. Check sensor power supply. Adjust and re-calibrate or replace sensor if necessary.
104	521021	4	Electrical System	Reel Height	High Alarm	Sensor voltage above 4.5 V. Check for wiring damage. Adjust and re-calibrate or replace sensor if necessary.
104	521021	5	Electrical System	Reel Height	Low Error	Sensor voltage below 0.5 V. Check sensor power supply. Adjust and re-calibrate or replace sensor if necessary.
104	521021	6	Electrical System	Reel Height	High Error	Sensor voltage above 4.5 V. Check for wiring damage. Adjust and re-calibrate or replace sensor if necessary.
104	521021	8	Electrical System	Reel Height	Vref Error	Reference voltage error. Check sensor wiring for damage.

REFERENCE

Fault Codes			Telltale	Short Description	Full Fault Description	Recommended Fix/Check Message
SA	SPN	FMI				
104	521024	3	Electrical System	Reel Fore-Aft	Low Alarm	Sensor voltage below 0.5 V. Check sensor power supply. Adjust and re-calibrate or replace sensor if necessary.
104	521024	4	Electrical System	Reel Fore-Aft	High Alarm	Sensor voltage above 4.5 V. Check for wiring damage. Adjust and re-calibrate or replace sensor if necessary.
104	521024	5	Electrical System	Reel Fore-Aft	Low Error	Sensor voltage below 0.5 V. Check sensor power supply. Adjust and re-calibrate or replace sensor if necessary.
104	521024	6	Electrical System	Reel Fore-Aft	High Error	Sensor voltage above 4.5 V. Check for wiring damage. Adjust and re-calibrate or replace sensor if necessary.
104	521024	8	Electrical System	Reel Fore-Aft	Vref Error	Reference voltage error. Check sensor wiring for damage.
104	521027	3	Electrical System	Lateral Tilt	Low Alarm	Sensor voltage below 0.5 V. Check sensor power supply. Adjust and re-calibrate or replace sensor if necessary.
104	521027	4	Electrical System	Lateral Tilt	High Alarm	Sensor voltage above 4.5 V. Check for wiring damage. Adjust and re-calibrate or replace sensor if necessary.
104	521027	5	Electrical System	Lateral Tilt	Low Error	Sensor voltage below 0.5 V. Check sensor power supply. Adjust and re-calibrate or replace sensor if necessary.
104	521027	6	Electrical System	Lateral Tilt	High Error	Sensor voltage above 4.5 V. Check for wiring damage. Adjust and re-calibrate or replace sensor if necessary.
104	521027	8	Electrical System	Lateral Tilt	Vref Error	Reference voltage error. Check sensor wiring for damage.
104	521030	3	Electrical System	Left Float Cyl.	Low Alarm	Sensor voltage below 0.5 V. Check sensor power supply. Adjust and re-calibrate or replace sensor if necessary.
104	521030	4	Electrical System	Left Float Cyl.	High Alarm	Sensor voltage above 4.5 V. Check for wiring damage. Adjust and re-calibrate or replace sensor if necessary.

REFERENCE

SA	Fault Codes		Telltale	Short Description	Full Fault Description	Recommended Fix/Check Message
	SPN	FMI				
104	521030	5	Electrical System	Left Float Cyl.	Low Error	Sensor voltage below 0.5 V. Check sensor power supply. Adjust and re-calibrate or replace sensor if necessary.
104	521030	6	Electrical System	Left Float Cyl.	High Error	Sensor voltage above 4.5 V. Check for wiring damage. Adjust and re-calibrate or replace sensor if necessary.
104	521030	8	Electrical System	Left Float Cyl.	Vref Error	Reference voltage error. Check sensor wiring for damage.
104	521033	3	Electrical System	Conveyor Pressure	Low Alarm	Sensor voltage below 0.5 V. Check sensor power supply and replace sensor as necessary. Ensure that DWA option (in Attachments menu) is checked off only if it is in fact installed.
104	521033	4	Electrical System	Conveyor Pressure	High Alarm	Sensor voltage above 4.5 V. Check for wiring damage and replace sensor as necessary. Ensure that DWA option (in Attachments menu) is checked off only if it is in fact installed.
104	521033	5	Electrical System	Conveyor Pressure	Low Error	Sensor voltage below 0.5 V. Check sensor power supply and replace sensor as necessary. Ensure that DWA option (in Attachments menu) is checked off only if it is in fact installed.
104	521033	6	Electrical System	Conveyor Pressure	High Error	Sensor voltage above 4.5 V. Check for wiring damage and replace sensor as necessary. Ensure that DWA option (in Attachments menu) is checked off only if it is in fact installed.
104	521033	8	Electrical System	Conveyor Pressure	Vref Error	Reference voltage error. Check sensor wiring for damage. Ensure that DWA option (in Attachments menu) is checked off only if it is in fact installed.
104	521036	3	Electrical System	Right Float Cyl.	Low Alarm	Sensor voltage below 0.5 V. Check sensor power supply. Adjust and re-calibrate or replace sensor if necessary.
104	521036	4	Electrical System	Right Float Cyl.	High Alarm	Sensor voltage above 4.5 V. Check for wiring damage. Adjust and re-calibrate or replace sensor if necessary.

REFERENCE

Fault Codes		Telltale	Short Description	Full Fault Description	Recommended Fix/Check Message	
SA	SPN					FMI
104	521036	5	Electrical System	Right Float Cyl.	Low Error	Sensor voltage below 0.5 V. Check sensor power supply. Adjust and re-calibrate or replace sensor if necessary.
104	521036	6	Electrical System	Right Float Cyl.	High Error	Sensor voltage above 4.5 V. Check for wiring damage. Adjust and re-calibrate or replace sensor if necessary.
104	521036	8	Electrical System	Right Float Cyl.	Vref Error	Reference voltage error. Check sensor wiring for damage.
104	521039	3	Electrical System	Knife Pressure	Low Alarm	Sensor voltage below 0.5 V. Check sensor power supply and replace sensor as necessary.
104	521039	4	Electrical System	Knife Pressure	High Alarm	Sensor voltage above 4.5 V. Check for wiring damage and replace sensor as necessary.
104	521039	5	Electrical System	Knife Pressure	Low Error	Sensor voltage below 0.5 V. Check sensor power supply and replace sensor as necessary.
104	521039	6	Electrical System	Knife Pressure	High Error	Sensor voltage above 4.5 V. Check for wiring damage and replace sensor as necessary.
104	521039	8	Electrical System	Knife Pressure	Vref Error	Reference voltage error. Check sensor wiring for damage.
104	521042	3	Electrical System	Reel Pressure	Low Alarm	Sensor voltage below 0.5 V. Check sensor power supply. Adjust and re-calibrate or Replace sensor if necessary.
104	521042	4	Electrical System	Reel Pressure	High Alarm	Sensor voltage above 4.5 V. Check for wiring damage. Adjust and re-calibrate or Replace sensor if necessary.
104	521042	5	Electrical System	Reel Pressure	Low Error	Sensor voltage below 0.5 V. Check sensor power supply. Adjust and re-calibrate or Replace sensor if necessary.
104	521042	6	Electrical System	Reel Pressure	High Error	Sensor voltage above 4.5 V. Check for wiring damage. Adjust and re-calibrate or Replace sensor if necessary.
104	521042	8	Electrical System	Reel Pressure	Vref Error	Reference voltage error. Check sensor wiring for damage.

REFERENCE

Fault Codes			Telltale	Short Description	Full Fault Description	Recommended Fix/Check Message
SA	SPN	FMI				
104	521045	3	Electrical System	Header Tilt	Low Alarm	Sensor voltage below 0.5 V. Check sensor power supply. Adjust and re-calibrate or Replace sensor if necessary.
104	521045	4	Electrical System	Header Tilt	High Alarm	Sensor voltage above 4.5 V. Check for wiring damage. Adjust and re-calibrate or Replace sensor if necessary.
104	521045	5	Electrical System	Header Tilt	Low Error	Sensor voltage below 0.5 V. Check sensor power supply. Adjust and re-calibrate or replace sensor if necessary.
104	521045	6	Electrical System	Header Tilt	High Error	Sensor voltage above 4.5 V. Check for wiring damage. Adjust and re-calibrate or replace sensor if necessary.
104	521045	8	Electrical System	Header Tilt	Vref Error	Reference voltage error. Check sensor wiring for damage.
104	521048	3	Electrical System	Header Height	Low Alarm	Sensor voltage below 0.5 V. Check sensor power supply. Adjust and re-calibrate or replace sensor if necessary.
104	521048	4	Electrical System	Header Height	High Alarm	Sensor voltage above 4.5 V. Check for wiring damage. Adjust and re-calibrate or replace sensor if necessary.
104	521048	5	Electrical System	Header Height	Low Error	Sensor voltage below 0.5 V. Check sensor power supply. Adjust and re-calibrate or replace sensor if necessary.
104	521048	6	Electrical System	Header Height	High Error	Sensor voltage above 4.5 V. Check for wiring damage. Adjust and re-calibrate or replace sensor if necessary.
104	521048	8	Electrical System	Header Height	Vref Error	Reference voltage error. Check sensor wiring for damage.
104	521051	3	Electrical System	Charge Pressure	Low Alarm	Sensor voltage below 0.5 V. Check sensor power supply and replace sensor as necessary.
104	521051	4	Electrical System	Charge Pressure	High Alarm	Sensor voltage above 4.5 V. Check for wiring damage and replace sensor as necessary.

REFERENCE

Fault Codes			Telltale	Short Description	Full Fault Description	Recommended Fix/Check Message
SA	SPN	FMI				
104	521051	5	Electrical System	Charge Pressure	Low Error	Sensor voltage below 0.5 V. Check sensor power supply and replace sensor as necessary.
104	521051	6	Electrical System	Charge Pressure	High Error	Sensor voltage above 4.5 V. Check for wiring damage and replace sensor as necessary.
104	521051	8	Electrical System	Charge Pressure	Vref Error	Reference voltage error. Check sensor wiring for damage.
104	521362	19	Electrical System	Cab Fwd Stop Lt Snsr	CAN Error	Contact Dealer.
104	521059	19	Electrical System	Cooler Box Door	CAN Error	Contact Dealer.
104	521060	19	Electrical System	Seat Cab Fwd	CAN Error	Contact Dealer.
104	521061	19	Electrical System	Seat Engine Fwd	CAN Error	Contact Dealer.
104	521062	19	Electrical System	Interlock Closed	CAN Error	Contact Dealer.
104	521063	19	Electrical System	Oil Level Signal	CAN Error	Contact Dealer.
104	521063	1	Windrower	Oil Level Low	Low Hydraulic Oil Level	Low Hydraulic Oil Level, or oil level switch failed or open wiring circuit. Shut off engine and check oil level. Check sensor wiring and replace sensor if necessary.
104	521064	19	Electrical System	Hyd Filter Ind	CAN Error	Contact Dealer.
104	521065	19	Electrical System	DWA Position Switch	CAN Error	Contact Dealer.
104	521066	19	Electrical System	Header ID1	CAN Error	Contact Dealer.
104	521067	19	Electrical System	Header ID2	CAN Error	Contact Dealer.
104	521068	19	Electrical System	Header ID3	CAN Error	Contact Dealer.

REFERENCE

Fault Codes		Telltale	Short Description	Full Fault Description	Recommended Fix/Check Message
SA	SPN				
104	521069	Electrical System	Header ID4	CAN Error	Contact Dealer.
104	521070	Electrical System	Header ID5	CAN Error	Contact Dealer.
104	521071	Electrical System	Left Wheel Motor	Low Alarm	Sensor voltage below 0.5 V. Check sensor power supply and replace sensor as necessary.
104	521071	Electrical System	Left Wheel Motor	High Alarm	Sensor voltage above 4.5 V. Check for wiring damage and replace sensor as necessary.
104	521072	Electrical System	Right Wheel Motor	Low Alarm	Sensor voltage below 0.5 V. Check sensor power supply and replace sensor as necessary.
104	521072	Electrical System	Right Wheel Motor	High Alarm	Sensor voltage above 4.5 V. Check for wiring damage and replace sensor as necessary.
104	521460	Windrower	Wheel Speed	Left Wheel Speed Sensor	Check left wheel speed sensor and wiring. Reading speed off Right wheel only. Auto-reel and auto-drapeer speed performance will be impacted while turning.
104	521460	Windrower	Wheel Speed	Right Wheel Speed Sensor	Check right wheel speed sensor and wiring. Reading speed off left wheel only. Auto-reel and auto-drapeer speed performance will be impacted while turning.
104	521460	Windrower	Wheel Speed	Left & Right Wheel Speed Sensor	Check right and left wheel speed sensors and wiring. Acre tracking, auto-reel and auto-drapeer speed features will be disabled.
104	521073	Electrical System	Knife/Disc Speed	Low Alarm	Sensor voltage below 0.5 V. Check sensor power supply. Check sensor adjustment and replace if necessary.
104	521073	Electrical System	Knife/Disc Speed	High Alarm	Sensor voltage above 4.5 V. Check for wiring damage. Check sensor adjustment and replace if necessary.
104	521073	Electrical System	Knife/Disc Speed	Condition Exists	No knife/disc speed feedback. Estimated speed will be used, This will exclude knife/disc speed changes when selecting buttons A, B and C on ground speed lever.

REFERENCE

Fault Codes			Telltale	Short Description	Full Fault Description	Recommended Fix/Check Message
SA	SPN	FMI				
104	521390	0	Windrower	Knife Speed	Above Norm Most Severe	Knife speed above max allowable for header type. Contact Dealer.
104	521074	2	Electrical System	Reel Speed	Low Alarm	Sensor voltage below 0.5 V. Check sensor power supply. Check sensor adjustment and replace if necessary.
104	521074	3	Electrical System	Reel Speed	High Alarm	Sensor voltage above 4.5 V. Check for wiring damage. Check sensor adjustment and replace if necessary.
104	521074	31	Electrical System	Reel Speed	Condition Exists	No reel speed feedback. This will exclude reel speed changes when selecting buttons A, B and C on ground speed lever. It will also disable the auto-reel speed feature.
104	521075	2	Electrical System	Cooling Fan Spd	Low Alarm	Sensor voltage below 0.5 V. Check sensor power supply. Check sensor adjustment and replace if necessary.
104	521075	3	Electrical System	Cooling Fan Spd	High Alarm	Sensor voltage above 4.5 V. Check for wiring damage. Check sensor adjustment and replace if necessary.
104	521391	0	Windrower	Cooling Fan Spd High	Above Norm Most Severe	Fan speed readout high. Safe mode activated. Fan will default to full rpm at high idle. Contact Dealer.
104	521391	31	Windrower	Cooling Fan Speed	Condition Exists	No cooling fan speed feedback.
104	521391	1	Windrower	Cooling Fan Spd Low	Below Normal Most Severe	Control system is unable to adjust fan speed. Beware that there is the potential for engine overheat if fan speed is too low. Safe mode activated. Fan will default to full rpm at high idle. Contact dealer.
104	521076	2	Electrical System	Left Draper Idler Spd	Low Alarm	Sensor voltage below 0.5 V. Check sensor power supply. Check sensor adjustment and replace if necessary. If a double draper drive kit is installed, select it from the Settings > Header > Attachments menu.
104	521076	3	Electrical System	Left Draper Idler Spd	High Alarm	Sensor voltage above 4.5 V. Check for wiring damage. Check sensor adjustment and replace if necessary.

REFERENCE

Fault Codes		Telltale	Short Description	Full Fault Description	Recommended Fix/Check Message	
SA	SPN					FMI
104	521076	31	Electrical System	Left Draper Idler Spd	Condition Exists	No draper slip feedback. Draper slip detection is no longer active. If a double draper drive kit is installed, select it from the Settings > Header > Attachments menu.
104	521077	2	Electrical System	Right Draper Idler Spd	Low Alarm	Sensor voltage below 0.5 V. Check sensor power supply. Check sensor adjustment and replace if necessary. If a double draper drive kit is installed, select it from the Settings > Header > Attachments menu.
104	521077	3	Electrical System	Right Draper Idler Spd	High Alarm	Sensor voltage above 4.5 V. Check for wiring damage. Check sensor adjustment and replace if necessary.
104	521077	31	Electrical System	Right Draper Idler Spd	Condition Exists	No draper slip feedback. Draper slip detection is no longer active. If a double draper drive kit is installed, select it from the Settings > Header > Attachments menu.
104	521078	4	Electrical System	Knife Drive	Open Load	Check wiring for damage or breaks. Contact Dealer.
104	521078	3	Electrical System	Knife Drive	Overload	High current on circuit. Check wiring for damage. Contact Dealer.
104	521078	2	Electrical System	Knife Drive	Saturated	Check current output channel on Master Controller.
104	521079	4	Electrical System	Left Wheel Motor	Open Load	Check wiring for damage or breaks. Contact Dealer.
104	521079	3	Electrical System	Left Wheel Motor	Overload	High current on circuit. Check wiring for damage. Contact Dealer.
104	521079	2	Electrical System	Left Wheel Motor	Saturated	Check current output channel on Master Controller.
104	521080	4	Electrical System	Right Wheel Motor	Open Load	Check wiring for damage or breaks. Contact Dealer.
104	521080	3	Electrical System	Right Wheel Motor	Overload	High current on circuit. Check wiring for damage. Contact Dealer.
104	521080	2	Electrical System	Right Wheel Motor	Saturated	Check current output channel on Master Controller.

REFERENCE

Fault Codes			Telltale	Short Description	Full Fault Description	Recommended Fix/Check Message
SA	SPN	FMI				
104	521081	4	Electrical System	Cooling Fan Speed	Open Load	Check wiring for damage or breaks. Contact Dealer.
104	521081	3	Electrical System	Cooling Fan Speed	Overload	High current on circuit. Check wiring for damage. Contact Dealer.
104	521081	2	Electrical System	Cooling Fan Speed	Saturated	Check current output channel on Master Controller.
104	521082	4	Electrical System	Header Raise/Lower	Open Load	Check wiring for damage or breaks. Contact Dealer.
104	521082	5	Electrical System	Header Raise/Lower	Overload	High current on circuit. Check wiring for damage. Contact Dealer.
104	521083	4	Electrical System	Header Tilt	Open Load	Check circuit for damage. Contact Dealer.
104	521083	5	Electrical System	Header Tilt	Overload	Check circuit for damage. Contact Dealer.
104	521085	4	Electrical System	Reel Drive PWM	Open Load	Check circuit for damage. Contact Dealer.
104	521085	5	Electrical System	Reel Drive PWM	Overload	Check circuit for damage. Contact Dealer.
104	521086	4	Electrical System	Conveyor Drive PWM	Open Load	Check wiring for damage or breaks. Contact Dealer.
104	521086	5	Electrical System	Conveyor Drive PWM	Overload	High current on circuit. Check wiring for damage. Contact Dealer.
104	521357	3	Electrical System	Interlock Open	Open Load	Check wiring for damage or breaks. Contact Dealer.
104	521357	4	Electrical System	Interlock Open	Overload	High current on circuit. Check wiring for damage. Contact Dealer.
104	521359	3	Electrical System	Brake Release	Open Load	Check wiring for damage or breaks. Contact Dealer.
104	521359	4	Electrical System	Brake Release	Overload	High current on circuit. Check wiring for damage. Contact Dealer.
104	521361	3	Electrical System	Batt. Disc. Open	Open Load	Check wiring for damage or breaks. Contact Dealer.

REFERENCE

Fault Codes		Telltale	Short Description	Full Fault Description	Recommended Fix/Check Message
SA	SPN				
104	521361	Electrical System	Batt. Disc. Open	Overload	High current on circuit. Check wiring for damage. Contact Dealer.
104	521364	Electrical System	Ignition	Open Load	Check wiring for damage or breaks. Contact Dealer.
104	521364	Electrical System	Ignition	Overload	High current on circuit. Check wiring for damage. Contact Dealer.
104	521366	Electrical System	Starter Relay	Open Load	Check wiring for damage or breaks. Contact Dealer.
104	521366	Electrical System	Starter Relay	Overload	High current on circuit. Check wiring for damage. Contact Dealer.
104	521368	Electrical System	12 V Sensor Pwr	Firewall 12 V Sensor Power - Open Load	Check wiring for damage or breaks. The following sensors may be affected: hydraulic oil temperature, hydraulic oil level, cooling fan speed, cab forward or engine-forward seat position, or hydraulic oil filter.Contact Dealer.
104	521368	Electrical System	12 V Sensor Pwr	Firewall 12 V Sensor Power - Overload	High current on circuit. Check wiring for damage. The following sensors may be affected: hydraulic oil temperature, hydraulic oil level, cooling fan speed, cab forward or engine-forward seat position, or hydraulic oil filter.Contact Dealer.
104	521369	Electrical System	Cooling Fan Reverse	Open Load	Check wiring for damage or breaks. Contact Dealer.
104	521369	Electrical System	Cooling Fan Reverse	Overload	High current on circuit. Check wiring for damage. Contact Dealer.
104	521370	Electrical System	Reel/Aux Lift Selector	Open Load	Check wiring for damage or breaks. Contact Dealer.
104	521370	Electrical System	Reel/Aux Lift Selector	Overload	High current on circuit. Check wiring for damage. Contact Dealer.
104	521371	Electrical System	Reel Retract O/P	Open Load	Check wiring for damage or breaks. Contact Dealer.
104	521371	Electrical System	Reel Retract O/P	Overload	High current on circuit. Check wiring for damage. Contact Dealer.

REFERENCE

Fault Codes		Telltale	Short Description	Full Fault Description	Recommended Fix/Check Message
SA	SPN				
104	521372	Electrical System	Reel Extend O/P	Open Load	Check wiring for damage or breaks. Contact Dealer.
104	521372	Electrical System	Reel Extend O/P	Overload	High current on circuit. Check wiring for damage. Contact Dealer.
104	521373	Electrical System	Reel Raise O/P	Open Load	Check wiring for damage or breaks. Contact Dealer.
104	521373	Electrical System	Reel Raise O/P	Overload	High current on circuit. Check wiring for damage. Contact Dealer.
104	521374	Electrical System	Reel Lower O/P	Open Load	Check wiring for damage or breaks. Contact Dealer.
104	521374	Electrical System	Reel Lower O/P	Overload	High current on circuit. Check wiring for damage. Contact Dealer.
104	521375	Electrical System	12 V Sensor Pwr	Chassis 12 V Sensor Power - Open Load	Check wiring for damage or breaks. The following sensors may be affected: DWA Position, header tilt position, swath compressor position. Contact Dealer.
104	521375	Electrical System	12 V Sensor Pwr	Chassis 12 V Sensor Power - Overload	High current on circuit. Check wiring for damage. The following sensors may be affected: DWA Position, header tilt position, swath compressor position. Contact Dealer.
104	521376	Electrical System	Deck Shift Left O/P	Open Load	Check wiring for damage or breaks. Contact Dealer.
104	521376	Electrical System	Deck Shift Left O/P	Overload	High current on circuit. Check wiring for damage. Contact Dealer.
104	521377	Electrical System	Deck Shift Right O/P	Open Load	Check wiring for damage or breaks. Contact Dealer.
104	521377	Electrical System	Deck Shift Right O/P	Overload	High current on circuit. Check wiring for damage. Contact Dealer.
104	521378	Electrical System	Left Lateral Tilt O/P	Open Load	Check wiring for damage or breaks. Contact Dealer.
104	521378	Electrical System	Left Lateral Tilt O/P	Overload	High current on circuit. Check wiring for damage. Contact Dealer.

REFERENCE

Fault Codes		Telltale	Short Description	Full Fault Description	Recommended Fix/Check Message
SA	SPN				
104	521379	Electrical System	Right Lateral Tilt O/P	Open Load	Check wiring for damage or breaks. Contact Dealer.
104	521379	Electrical System	Right Lateral Tilt O/P	Overload	High current on circuit. Check wiring for damage. Contact Dealer.
104	521380	Electrical System	Right Float Adjust O/P	Open Load	Check wiring for damage or breaks. Contact Dealer.
104	521380	Electrical System	Right Float Adjust O/P	Overload	High current on circuit. Check wiring for damage. Contact Dealer.
104	521381	Electrical System	Left Float Adjust O/P	Open Load	Check wiring for damage or breaks. Contact Dealer.
104	521381	Electrical System	Left Float Adjust O/P	Overload	High current on circuit. Check wiring for damage. Contact Dealer.
104	521087	Electrical System	Master Controller	Disabled	Contact Dealer.
104	521087	Electrical System	Master Controller	High Temperature	Module has exceeded max operating temperature. Allow module to cool down before continuing operation.
104	521087	Electrical System	Master Controller	Low Batt Voltage	Battery voltage is low, check charging system. Contact Dealer.
104	521087	Electrical System	Master Controller	High Batt Voltage	Battery voltage is high. Contact Dealer.
104	521087	Electrical System	Master Controller	Vref Error	Reference voltage error. Check wiring for damage. The following sensors may be affected: Left Hand Wheel Speed Right Hand Wheel Speed Fuel Level Ground Speed Lever Position
104	521087	Electrical System	Master Controller	MultiAddress	Check address wiring.
104	521087	Electrical System	Master Controller	Address Error	CAN Address Error. Contact Dealer.
104	521092	Electrical System	Ext. Module, Firewall	Disabled	Contact Dealer.

REFERENCE

Fault Codes		SA	SPN	FMI	Telltale	Short Description	Full Fault Description	Recommended Fix/Check Message
104	521092							
104	521092	3	Electrical System	Ext. Module, Firewall	Low Batt Voltage	Battery voltage is low, check charging system. Contact Dealer.		
104	521092	4	Electrical System	Ext. Module, Firewall	High Batt Voltage	Battery voltage is high. Contact Dealer.		
104	521092	6	Electrical System	Ext. Module, Firewall	Address Error	CAN Address Error. Contact Dealer.		
104	521092	7	Electrical System	Ext. Module, Firewall	Vref error	Reference voltage error. Check wiring for damage.		
104	521097	1	Electrical System	Ext. Module, Chassis	Disabled	Contact Dealer.		
104	521097	2	Electrical System	Ext. Module, Chassis	High Temperature	Module has exceeded max operating temperature. Allow module to cool down before continuing operation.		
104	521097	3	Electrical System	Ext. Module, Chassis	Low Batt Voltage	Battery voltage is low, check charging system. Contact Dealer.		
104	521097	4	Electrical System	Ext. Module, Chassis	High Batt Voltage	Battery voltage is high. Contact Dealer.		
104	521097	6	Electrical System	Ext. Module, Chassis	Address Error	CAN Address Error. Contact Dealer.		
104	521097	7	Electrical System	Ext. Module, Chassis	Vref error	Reference voltage error. Check wiring for damage.		
104	521501	3	Electrical System	Swath Compressor	Low Alarm	Sensor voltage below 0.5 V. Check sensor power supply. Adjust and re-calibrate or replace sensor if necessary.		
104	521501	4	Electrical System	Swath Compressor	High Alarm	Sensor voltage above 4.5 V. Check for wiring damage. Adjust and re-calibrate or replace sensor if necessary.		
104	521501	5	Electrical System	Swath Compressor	Low Error	Sensor voltage below 0.5 V. Check sensor power supply. Adjust and re-calibrate or replace sensor if necessary.		

REFERENCE

Fault Codes		Telltale	Short Description	Full Fault Description	Recommended Fix/Check Message
SA	SPN				
104	521501	Electrical System	Swath Compressor	High Error	Sensor voltage above 4.5 V. Check for wiring damage. Adjust and re-calibrate or replace sensor if necessary.
104	521501	Electrical System	Swath Compressor	Vref Error	Reference voltage error. Check sensor wiring for damage.
104	521502	Electrical System	AHHC Left-out Sensor	Low Alarm	Sensor voltage below 0.5 V. Check sensor power supply. Adjust and re-calibrate or replace sensor if necessary.
104	521502	Electrical System	AHHC Left-out Sensor	High Alarm	Sensor voltage above 4.5 V. Check for wiring damage. Adjust and re-calibrate or replace sensor if necessary.
104	521502	Electrical System	AHHC Left-out Sensor	Low Error	Sensor voltage below 0.5 V. Check sensor power supply. Adjust and re-calibrate or replace sensor if necessary.
104	521502	Electrical System	AHHC Left-out Sensor	High Error	Sensor voltage above 4.5 V. Check for wiring damage. Adjust and re-calibrate or replace sensor if necessary.
104	521502	Electrical System	AHHC Left-out Sensor	Vref Error	Reference voltage error. Check sensor wiring for damage.
104	521503	Electrical System	AHHC Left-in Sensor	Low Alarm	Sensor voltage below 0.5 V. Check sensor power supply. Adjust and re-calibrate or replace sensor if necessary.
104	521503	Electrical System	AHHC Left-in Sensor	High Alarm	Sensor voltage above 4.5 V. Check for wiring damage. Adjust and re-calibrate or replace sensor if necessary.
104	521503	Electrical System	AHHC Left-in Sensor	Low Error	Sensor voltage below 0.5 V. Check sensor power supply. Adjust and re-calibrate or replace sensor if necessary.
104	521503	Electrical System	AHHC Left-in Sensor	High Error	Sensor voltage above 4.5 V. Check for wiring damage. Adjust and re-calibrate or replace sensor if necessary.
104	521503	Electrical System	AHHC Left-in Sensor	Vref Error	Reference voltage error. Check sensor wiring for damage.

REFERENCE

Fault Codes		Telltale	Short Description	Full Fault Description	Recommended Fix/Check Message
SA	SPN				
104	521504	Electrical System	AHHC Right-in Sensor	Low Alarm	Sensor voltage below 0.5 V. Check sensor power supply. Adjust and re-calibrate or replace sensor if necessary.
104	521504	Electrical System	AHHC Right-in Sensor	High Alarm	Sensor voltage above 4.5 V. Check for wiring damage. Adjust and re-calibrate or replace sensor if necessary.
104	521504	Electrical System	AHHC Right-in Sensor	Low Error	Sensor voltage below 0.5 V. Check sensor power supply. Adjust and re-calibrate or replace sensor if necessary.
104	521504	Electrical System	AHHC Right-in Sensor	High Error	Sensor voltage above 4.5 V. Check for wiring damage. Adjust and re-calibrate or replace sensor if necessary.
104	521504	Electrical System	AHHC Right-in Sensor	Vref Error	Reference voltage error. Check sensor wiring for damage.
104	521505	Electrical System	AHHC Right-out Sensor	Low Alarm	Sensor voltage below 0.5 V. Check sensor power supply. Adjust and re-calibrate or replace sensor if necessary.
104	521505	Electrical System	AHHC Right-out Sensor	High Alarm	Sensor voltage above 4.5 V. Check for wiring damage. Adjust and re-calibrate or replace sensor if necessary.
104	521505	Electrical System	AHHC Right-out Sensor	Low Error	Sensor voltage below 0.5 V. Check sensor power supply. Adjust and re-calibrate or replace sensor if necessary.
104	521505	Electrical System	AHHC Right-out Sensor	High Error	Sensor voltage above 4.5 V. Check for wiring damage. Adjust and re-calibrate or replace sensor if necessary.
104	521505	Electrical System	AHHC Right-out Sensor	Vref Error	Reference voltage error. Check sensor wiring for damage.
104	521506	Electrical System	VREF Ext. Mod, Firewall	CAN Error	Contact Dealer The following sensors may be affected: knife speed, reel speed, left or right draper speed, header identification, reel height position, reel fore-aft position, and hydraulic oil temperature.

REFERENCE

Fault Codes		Telltale	Short Description	Full Fault Description	Recommended Fix/Check Message	
SA	SPN					FMI
104	521506	3	Electrical System	VREF Ext. Mod, Firewall	Open Load	Check wiring for damage or breaks. The following sensors may be affected: knife speed, reel speed, left or right draper speed, header identification, reel height position, reel fore-aft position, and hydraulic oil temperature. Contact Dealer.
104	521506	4	Electrical System	VREF Ext. Mod, Firewall	Overload	High current on circuit. Check wiring for damage. The following sensors may be affected: knife speed, reel speed, left or right draper speed, header identification, reel height position, reel fore-aft position, and hydraulic oil temperature. Contact Dealer.
104	521507	2	Electrical System	VREF Ext. Mod, Chassis	CAN Error	Contact Dealer The following sensors may be affected: knife pressure, reel pressure, draper pressure, supercharge pressure, left and right float position, header height position, header tilt position, and swath compressor position.
104	521507	3	Electrical System	VREF Ext. Mod, Chassis	Open Load	Check wiring for damage or breaks. The following sensors may be affected: knife pressure, reel pressure, draper pressure, supercharge pressure, left and right float position, header height position, header tilt position, and swath compressor position. Contact Dealer.
104	521507	4	Electrical System	VREF Ext. Mod, Chassis	Overload	High current on circuit. Check wiring for damage. The following sensors may be affected: knife pressure, reel pressure, draper pressure, supercharge pressure, left and right float position, header height position, header tilt position, and swath compressor position. Contact Dealer.
104	521509	19	Electrical System	Gearbox Oil Level Signal	CAN Error - Gearbox Oil Low Level Sensor	Contact Dealer.
104	521509	1	Windrower	Gearbox Oil Level Low	Low Gearbox Oil Level	Low Gearbox Oil Level, or oil level switch failed or open wiring circuit. Shut off engine and check oil level. Check sensor wiring and replace sensor if necessary.

REFERENCE

Fault Codes			Telltale	Short Description	Full Fault Description	Recommended Fix/Check Message
SA	SPN	FMI				
104	521510	19	Electrical System	Gearbox Oil Level Signal	CAN Error - Gearbox Oil High Level Sensor	Contact Dealer.
104	521510	1	Windrower	Gearbox Oil Level High	High Gearbox Oil Level	High Gearbox Oil Level, or oil level switch failed. Shut off engine and check oil level. Check sensor wiring and replace sensor if necessary.
104	521530	1	Windrower	Reel Pressure High	The reel circuit is operating at high pressure. This may be caused by a blocked orifice in port OR1 of the reel and draper drive manifold, and/or excessive leakage through the flow control valve for the reel circuit.	Stop operating the windrower. Continued operation with header uncoupled may damage pump. Contact Dealer.
104	521531	1	Windrower	Conveyor Pressure High	The conveyor circuit is operating at high pressure. This may be caused by a blocked orifice in port OR2 of the reel and draper drive manifold, and/or excessive leakage through the flow control valve for the reel circuit.	Stop operating the windrower. Continued operation with header uncoupled may damage pump. Contact Dealer.
176	521104	1	Electrical System	Inner Work Lights	EK1 Relay coil open or not present	Check roof relay module.
176	521104	2	Electrical System	Inner Work Lights	EK1 Relay Coil shorted or failed relay driver	Check roof relay module.
176	521104	3	Electrical System	Inner Work Lights	EK1 Relay Normally Open contact is open	Check roof relay module.
176	521104	4	Electrical System	Inner Work Lights	EK1 Relay Normally Closed contact is open	Check roof relay module.
176	521104	5	Electrical System	Inner Work Lights	EK1 Relay coil is not receiving power	Check wiring to roof relay module EK1. Contact Dealer.
176	521104	6	Electrical System	Inner Work Lights	EK1 Relay Normally open contact is shorted	Check roof relay module.

REFERENCE

Fault Codes			Telltale	Short Description	Full Fault Description	Recommended Fix/Check Message
SA	SPN	FMI				
176	521104	7	Electrical System	Inner Work Lights	EK1 Relay Normally closed contact is shorted	Check roof relay module.
176	521111	1	Electrical System	Low Beam Light Cab Fwd	EK2 Relay coil open or not present	Check roof relay module.
176	521111	2	Electrical System	Low Beam Light Cab Fwd	EK2 Relay Coil shorted or failed relay driver	Check roof relay module.
176	521111	3	Electrical System	Low Beam Light Cab Fwd	EK2 Relay Normally Open contact is open	Check roof relay module.
176	521111	4	Electrical System	Low Beam Light Cab Fwd	EK2 Relay Normally Closed contact is open	Check roof relay module.
176	521111	5	Electrical System	Low Beam Light Cab Fwd	EK2 Relay coil is not receiving power	Check wiring to roof relay module EK2. Contact Dealer.
176	521111	6	Electrical System	Low Beam Light Cab Fwd	EK2 Relay Normally open contact is shorted	Check roof relay module.
176	521111	7	Electrical System	Low Beam Light Cab Fwd	EK2 Relay Normally closed contact is shorted	Check roof relay module.
176	521119	1	Electrical System	Tail Lights Engine Fwd	EK3 Relay coil open or not present	Check roof relay module.
176	521119	2	Electrical System	Tail Lights Engine Fwd	EK3 Relay Coil shorted or failed relay driver	Check roof relay module.
176	521119	3	Electrical System	Tail Lights Engine Fwd	EK3 Relay Normally Open contact is open	Check roof relay module.
176	521119	4	Electrical System	Tail Lights Engine Fwd	EK3 Relay Normally Closed contact is open	Check roof relay module.
176	521119	5	Electrical System	Tail Lights Engine Fwd	EK3 Relay coil is not receiving power	Check wiring to roof relay module EK3. Contact Dealer.
176	521119	6	Electrical System	Tail Lights Engine Fwd	EK3 Relay Normally open contact is shorted	Check roof relay module.
176	521119	7	Electrical System	Tail Lights Engine Fwd	EK3 Relay Normally closed contact is shorted	Check roof relay module.
176	521127	1	Electrical System	Outer Work Lights	EK4 Relay coil open or not present	Check roof relay module.

REFERENCE

Fault Codes		Telltale	Short Description	Full Fault Description	Recommended Fix/Check Message
SA	SPN				
176	521127	Electrical System	Outer Work Lights	EK4 Relay Coil shorted or failed relay driver	Check roof relay module.
176	521127	Electrical System	Outer Work Lights	EK4 Relay Normally Open contact is open	Check roof relay module.
176	521127	Electrical System	Outer Work Lights	EK4 Relay Normally Closed contact is open	Check roof relay module.
176	521127	Electrical System	Outer Work Lights	EK4 Relay coil is not receiving power	Check wiring to roof relay module EK4. Contact Dealer.
176	521127	Electrical System	Outer Work Lights	EK4 Relay Normally open contact is shorted	Check roof relay module.
176	521127	Electrical System	Outer Work Lights	EK4 Relay Normally closed contact is shorted	Check roof relay module.
176	521135	Electrical System	Rear Roof Work Lights	EK5 Relay coil open or not present	Check roof relay module.
176	521135	Electrical System	Rear Roof Work Lights	EK5 Relay Coil shorted or failed relay driver	Check roof relay module.
176	521135	Electrical System	Rear Roof Work Lights	EK5 Relay Normally Open contact is open	Check roof relay module.
176	521135	Electrical System	Rear Roof Work Lights	EK5 Relay Normally Closed contact is open	Check roof relay module.
176	521135	Electrical System	Rear Roof Work Lights	EK5 Relay coil is not receiving power	Check wiring to roof relay module EK5. Contact Dealer.
176	521135	Electrical System	Rear Roof Work Lights	EK5 Relay Normally open contact is shorted	Check roof relay module.
176	521143	Electrical System	High Beam Lights CF	EK6 Relay coil open or not present	Check roof relay module.
176	521143	Electrical System	High Beam Lights CF	EK6 Relay Coil shorted or failed relay driver	Check roof relay module.
176	521143	Electrical System	High Beam Lights CF	EK6 Relay Normally Open contact is open	Check roof relay module.

REFERENCE

Fault Codes		Telltale	Short Description	Full Fault Description	Recommended Fix/Check Message
SA	SPN				
176	521143	Electrical System	High Beam Lights CF	EK6 Relay Normally Closed contact is open	Check roof relay module.
176	521143	Electrical System	High Beam Lights CF	EK6 Relay coil is not receiving power	Check wiring to roof relay module EK6. Contact Dealer.
176	521143	Electrical System	High Beam Lights CF	EK6 Relay Normally open contact is shorted	Check roof relay module.
176	521143	Electrical System	High Beam Lights CF	EK6 Relay Normally closed contact is shorted	Check roof relay module.
176	521151	Electrical System	Brake Lights, Eng Fwd	EK7 Relay coil open or not present	Check roof relay module.
176	521151	Electrical System	Brake Lights, Eng Fwd	EK7 Relay Coil shorted or failed relay driver	Check roof relay module.
176	521151	Electrical System	Brake Lights, Eng Fwd	EK7 Relay Normally Open contact is open	Check roof relay module.
176	521151	Electrical System	Brake Lights, Eng Fwd	EK7 Relay Normally Closed contact is open	Check roof relay module.
176	521151	Electrical System	Brake Lights, Eng Fwd	EK7 Relay coil is not receiving power	Check wiring to roof relay module EK7. Contact Dealer.
176	521151	Electrical System	Brake Lights, Eng Fwd	EK7 Relay Normally open contact is shorted	Check roof relay module.
176	521159	Electrical System	Rear Swath Lights	EK8 Relay coil open or not present	Check roof relay module.
176	521159	Electrical System	Rear Swath Lights	EK8 Relay Coil shorted or failed relay driver	Check roof relay module.
176	521159	Electrical System	Rear Swath Lights	EK8 Relay Normally Open contact is open	Check roof relay module.
176	521159	Electrical System	Rear Swath Lights	EK8 Relay Normally Closed contact is open	Check roof relay module.
176	521159	Electrical System	Rear Swath Lights	EK8 Relay coil is not receiving power	Check wiring to roof relay module EK8. Contact Dealer.

REFERENCE

Fault Codes		Telltale	Short Description	Full Fault Description	Recommended Fix/Check Message
SA	SPN				
176	521159	Electrical System	Rear Swath Lights	EK8 Relay Normally open contact is shorted	Check roof relay module.
176	521159	Electrical System	Rear Swath Lights	EK8 Relay Normally closed contact is shorted	Check roof relay module.
176	521167	Electrical System	Beacon Lights	EK9 Relay coil open or not present	Check roof relay module.
176	521167	Electrical System	Beacon Lights	EK9 Relay Coil shorted or failed relay driver	Check roof relay module.
176	521167	Electrical System	Beacon Lights	EK9 Relay Normally Open contact is open	Check roof relay module.
176	521167	Electrical System	Beacon Lights	EK9 Relay Normally Closed contact is open	Check roof relay module.
176	521167	Electrical System	Beacon Lights	EK9 Relay coil is not receiving power	Check wiring to roof relay module EK9. Contact Dealer.
176	521167	Electrical System	Beacon Lights	EK9 Relay Normally open contact is shorted	Check roof relay module.
176	521167	Electrical System	Beacon Lights	EK9 Relay Normally closed contact is shorted	Check roof relay module.
176	521175	Electrical System	Dome Light, Cab	EK10 Relay coil open or not present	Check roof relay module.
176	521175	Electrical System	Dome Light, Cab	EK10 Relay Coil shorted or failed relay driver	Check roof relay module.
176	521175	Electrical System	Dome Light, Cab	EK10 Relay Normally Open contact is open	Check roof relay module.
176	521175	Electrical System	Dome Light, Cab	EK10 Relay Normally Closed contact is open	Check roof relay module.
176	521175	Electrical System	Dome Light, Cab	EK10 Relay coil is not receiving power	Check wiring to roof relay module EK10. Contact Dealer.
176	521175	Electrical System	Dome Light, Cab	EK10 Relay Normally open contact is shorted	Check roof relay module.
176	521175	Electrical System	Dome Light, Cab	EK10 Relay Normally closed contact is shorted	Check roof relay module.

REFERENCE

Fault Codes			Telltale	Short Description	Full Fault Description	Recommended Fix/Check Message
SA	SPN	FMI				
176	521185	1	Electrical System	Inner work lights	EC1 Circuit Breaker Blown	Check roof relay module.
176	521185	2	Electrical System	Inner work lights	EC1 Circuit Breaker Not Powered	Check wiring to roof relay module EC1 circuit breaker. Contact Dealer.
176	521185	3	Electrical System	Inner work lights	EC1 Circuit Breaker Not Used	Contact Dealer.
176	521288	1	Electrical System	Outer work lights	EC2 Circuit Breaker Blown	Check roof relay module.
176	521288	2	Electrical System	Outer work lights	EC2 Circuit Breaker Not Powered	Check wiring to roof relay module EC2 circuit breaker. Contact dealer.
176	521288	3	Electrical System	Outer work lights	EC2 Circuit Breaker Not Used	Contact Dealer.
176	521291	1	Electrical System	Brake Lights, Eng Fwd	EC3 Circuit Breaker Blown	Check roof relay module.
176	521291	2	Electrical System	Brake Lights, Eng Fwd	EC3 Circuit Breaker Not Powered	Check wiring to roof relay module EC3 circuit breaker. Contact Dealer.
176	521291	3	Electrical System	Brake Lights, Eng Fwd	EC3 Circuit Breaker Not Used	Contact Dealer.
176	521294	1	Electrical System	Low Beam Light Cab Fwd	EC4 Circuit Breaker Blown	Check roof relay module.
176	521294	2	Electrical System	Low Beam Light Cab Fwd	EC4 Circuit Breaker Not Powered	Check wiring to roof relay module EC4 circuit breaker. Contact Dealer.
176	521294	3	Electrical System	Low Beam Light Cab Fwd	EC4 Circuit Breaker Not Used	Contact Dealer.
176	521297	1	Electrical System	Rear Swath Lights	EC5 Circuit Breaker Blown	Check roof relay module.
176	521297	2	Electrical System	Rear Swath Lights	EC5 Circuit Breaker Not Powered	Check wiring to roof relay module EC5 circuit breaker. Contact Dealer.
176	521297	3	Electrical System	Rear Swath Lights	EC5 Circuit Breaker Not Used	Contact Dealer.
176	521300	1	Electrical System	High Beam Lights CF	EC6 Circuit Breaker Blown	Check roof relay module.

REFERENCE

Fault Codes			Telltale	Short Description	Full Fault Description	Recommended Fix/Check Message
SA	SPN	FMI				
176	521300	2	Electrical System	High Beam Lights CF	EC6 Circuit Breaker Not Powered	Check wiring to roof relay module EC6 circuit breaker. Contact Dealer.
176	521300	3	Electrical System	High Beam Lights CF	EC6 Circuit Breaker Not Used	Contact Dealer.
176	521303	1	Electrical System	Tail Lights Engine Fwd	EC7 Circuit Breaker Blown	Check roof relay module.
176	521303	2	Electrical System	Tail Lights Engine Fwd	EC7 Circuit Breaker Not Powered	Check wiring to roof relay module EC7 circuit breaker. Contact Dealer.
176	521303	3	Electrical System	Tail Lights Engine Fwd	EC7 Circuit Breaker Not Used	Contact Dealer.
176	521306	1	Electrical System	Rear Roof Work Lights	EC8 Circuit Breaker Blown	Check roof relay module.
176	521306	2	Electrical System	Rear Roof Work Lights	EC8 Circuit Breaker Not Powered	Check wiring to roof relay module EC8 circuit breaker. Contact Dealer.
176	521306	3	Electrical System	Rear Roof Work Lights	EC8 Circuit Breaker Not Used	Contact Dealer
176	521309	1	Electrical System	Beacon Lights	EC9 Circuit Breaker Blown	Check roof relay module.
176	521309	2	Electrical System	Beacon Lights	EC9 Circuit Breaker Not Powered	Check wiring to roof relay module EC9 circuit breaker. Contact Dealer.
176	521309	3	Electrical System	Beacon Lights	EC9 Circuit Breaker Not Used	Contact Dealer
176	521312	1	Electrical System	Dome Light, Cab	EC10 Circuit Breaker Blown	Check roof relay module.
176	521312	2	Electrical System	Dome Light, Cab	EC10 Circuit Breaker Not Powered	Check wiring to roof relay module EC10 circuit breaker. Contact Dealer.
176	521312	3	Electrical System	Dome Light, Cab	EC10 Circuit Breaker Not Used	Contact Dealer.
176	521474	1	Electrical System	Roof Relay Module	Error - Module, Roof mVEC	Contact Dealer.
176	521475	1	Electrical System	Roof Relay Module	Error - Module, Roof mVEC	Contact Dealer.

REFERENCE

Fault Codes		Telltale	Short Description	Full Fault Description	Recommended Fix/Check Message
SA	SPN				
176	521476	Electrical System	Roof Relay Module	Error - Module, Roof mVEC	Contact Dealer.
176	521477	Electrical System	Roof Relay Module	Error - Module, Roof mVEC	Contact Dealer.
176	521478	Electrical System	Roof Relay Module	Error - Module, Roof mVEC	Contact Dealer.
176	521479	Electrical System	Roof Relay Module	Error - Module, Roof mVEC	Contact Dealer.
176	521480	Electrical System	Roof Relay Module	Error - Module, Roof mVEC	Contact Dealer.
176	521481	Electrical System	Roof Relay Module	Error - Module, Roof mVEC	Contact Dealer.
176	521482	Electrical System	Roof Relay Module	Error - Module, Roof mVEC	Contact Dealer.
176	521483	Electrical System	Roof Relay Module	Error - Module, Roof mVEC	Contact Dealer.
176	521484	Electrical System	Roof Relay Module	Error - Module, Roof mVEC	Contact Dealer.
176	521485	Electrical System	Roof Relay Module	Error - Module, Roof mVEC	Contact Dealer.
176	521486	Electrical System	Roof Relay Module	Error - Module, Roof mVEC	Contact Dealer.
178	521186	Electrical System	Brake Lights, Cab Fwd	BK1 Relay coil open or not present	Check chassis module for missing relay. Replace relay.
178	521186	Electrical System	Brake Lights, Cab Fwd	BK1 Relay Coil shorted or failed relay driver	Replace relay.
178	521186	Electrical System	Brake Lights, Cab Fwd	BK1 Relay Normally Open contact is open	Replace relay.
178	521186	Electrical System	Brake Lights, Cab Fwd	BK1 Relay Normally Closed contact is open	Replace relay.
178	521186	Electrical System	Brake Lights, Cab Fwd	BK1 Relay coil is not receiving power	Contact Dealer.

REFERENCE

Fault Codes		Telltale	Short Description	Full Fault Description	Recommended Fix/Check Message
SA	SPN				
178	521186	Electrical System	Brake Lights, Cab Fwd	BK1 Relay Normally open contact is shorted	Replace relay.
178	521186	Electrical System	Brake Lights, Cab Fwd	BK1 Relay Normally closed contact is shorted	Replace relay.
178	521194	Electrical System	High Beam, Engine Fwd	BK2 Relay coil open or not present	Check chassis module for missing relay. Replace relay.
178	521194	Electrical System	High Beam, Engine Fwd	BK2 Relay Coil shorted or failed relay driver	Replace relay.
178	521194	Electrical System	High Beam, Engine Fwd	BK2 Relay Normally Open contact is open	Replace relay.
178	521194	Electrical System	High Beam, Engine Fwd	BK2 Relay Normally Closed contact is open	Replace relay.
178	521194	Electrical System	High Beam, Engine Fwd	BK2 Relay coil is not receiving power	Contact Dealer.
178	521194	Electrical System	High Beam, Engine Fwd	BK2 Relay Normally open contact is shorted	Replace relay.
178	521194	Electrical System	High Beam, Engine Fwd	BK2 Relay Normally closed contact is shorted	Replace relay.
178	521226	Electrical System	Right Turn Signal	BK3 Relay coil open or not present	Check chassis module for missing relay. Replace relay.
178	521226	Electrical System	Right Turn Signal	BK3 Relay Coil shorted or failed relay driver	Replace relay.
178	521226	Electrical System	Right Turn Signal	BK3 Relay Normally Open contact is open	Replace relay.
178	521226	Electrical System	Right Turn Signal	BK3 Relay Normally Closed contact is open	Replace relay.
178	521226	Electrical System	Right Turn Signal	BK3 Relay coil is not receiving power	Contact Dealer.
178	521226	Electrical System	Right Turn Signal	BK3 Relay Normally open contact is shorted	Replace relay.
178	521226	Electrical System	Right Turn Signal	BK3 Relay Normally closed contact is shorted	Replace relay.

REFERENCE

Fault Codes		Telltale	Short Description	Full Fault Description	Recommended Fix/Check Message
SA	SPN				
178	521210	Electrical System	Low Beam Lights, EF	BK5 Relay coil open or not present	Check chassis module for missing relay. Replace relay.
178	521210	Electrical System	Low Beam Lights, EF	BK5 Relay Coil shorted or failed relay driver	Replace relay.
178	521210	Electrical System	Low Beam Lights, EF	BK5 Relay Normally Open contact is open	Replace relay.
178	521210	Electrical System	Low Beam Lights, EF	BK5 Relay Normally Closed contact is open	Replace relay.
178	521210	Electrical System	Low Beam Lights, EF	BK5 Relay coil is not receiving power	Contact Dealer.
178	521210	Electrical System	Low Beam Lights, EF	BK5 Relay Normally open contact is shorted	Replace relay.
178	521210	Electrical System	Low Beam Lights, EF	BK5 Relay Normally closed contact is shorted	Replace relay.
178	521218	Electrical System	Left Turn Signal	BK6 Relay coil open or not present	Check chassis module for missing relay. Replace relay.
178	521218	Electrical System	Left Turn Signal	BK6 Relay Coil shorted or failed relay driver	Replace relay.
178	521218	Electrical System	Left Turn Signal	BK6 Relay Normally Open contact is open	Replace relay.
178	521218	Electrical System	Left Turn Signal	BK6 Relay Normally Closed contact is open	Replace relay.
178	521218	Electrical System	Left Turn Signal	BK6 Relay coil is not receiving power	Contact Dealer.
178	521218	Electrical System	Left Turn Signal	BK6 Relay Normally open contact is shorted	Replace relay.
178	521218	Electrical System	Left Turn Signal	BK6 Relay Normally closed contact is shorted	Replace relay.
178	521202	Electrical System	Wiper, Cab Fwd	BK7 Relay coil open or not present	Check chassis module for missing relay. Replace relay.
178	521202	Electrical System	Wiper, Cab Fwd	BK7 Relay Coil shorted or failed relay driver	Replace relay.

REFERENCE

Fault Codes			Telltale	Short Description	Full Fault Description	Recommended Fix/Check Message
SA	SPN	FMI				
178	521202	3	Electrical System	Wiper, Cab Fwd	BK7 Relay Normally Open contact is open	Replace relay.
178	521202	4	Electrical System	Wiper, Cab Fwd	BK7 Relay Normally Closed contact is open	Replace relay.
178	521202	5	Electrical System	Wiper, Cab Fwd	BK7 Relay coil is not receiving power	Contact Dealer.
178	521202	6	Electrical System	Wiper, Cab Fwd	BK7 Relay Normally open contact is shorted	Replace relay.
178	521202	7	Electrical System	Wiper, Cab Fwd	BK7 Relay Normally closed contact is shorted	Replace relay.
178	521234	1	Electrical System	Hydraulic Selector 1/2	BK9 Relay coil open or not present	Check chassis module for missing relay. Replace relay.
178	521234	2	Electrical System	Hydraulic Selector 1/2	BK9 Relay Coil shorted or failed relay driver	Replace relay.
178	521234	3	Electrical System	Hydraulic Selector 1/2	BK9 Relay Normally Open contact is open	Replace relay.
178	521234	4	Electrical System	Hydraulic Selector 1/2	BK9 Relay Normally Closed contact is open	Replace relay.
178	521234	5	Electrical System	Hydraulic Selector 1/2	BK9 Relay coil is not receiving power	Contact Dealer.
178	521234	6	Electrical System	Hydraulic Selector 1/2	BK9 Relay Normally open contact is shorted	Replace relay.
178	521234	7	Electrical System	Hydraulic Selector 1/2	BK9 Relay Normally closed contact is shorted	Replace relay.
178	521242	1	Electrical System	Wiper, Engine Fwd	BK8 Relay coil open or not present	Check chassis module for missing relay. Replace relay.
178	521242	2	Electrical System	Wiper, Engine Fwd	BK8 Relay Coil shorted or failed relay driver	Replace relay.
178	521242	3	Electrical System	Wiper, Engine Fwd	BK8 Relay Normally Open contact is open	Replace relay.
178	521242	4	Electrical System	Wiper, Engine Fwd	BK8 Relay Normally Closed contact is open	Replace relay.

REFERENCE

Fault Codes		Telltale	Short Description	Full Fault Description	Recommended Fix/Check Message
SA	SPN				
178	521242	Electrical System	Wiper, Engine Fwd	BK8 Relay coil is not receiving power	Contact Dealer.
178	521242	Electrical System	Wiper, Engine Fwd	BK8 Relay Normally open contact is shorted	Replace relay.
178	521242	Electrical System	Wiper, Engine Fwd	BK8 Relay Normally closed contact is shorted	Replace relay.
178	521250	Electrical System	Tail Lights, Cab Fwd	BK4 Relay coil open or not present	Check chassis module for missing relay. Replace relay.
178	521250	Electrical System	Tail Lights, Cab Fwd	BK4 Relay Coil shorted or failed relay driver	Replace relay.
178	521250	Electrical System	Tail Lights, Cab Fwd	BK4 Relay Normally Open contact is open	Replace relay.
178	521250	Electrical System	Tail Lights, Cab Fwd	BK4 Relay Normally Closed contact is open	Replace relay.
178	521250	Electrical System	Tail Lights, Cab Fwd	BK4 Relay coil is not receiving power	Contact Dealer.
178	521250	Electrical System	Tail Lights, Cab Fwd	BK4 Relay Normally open contact is shorted	Replace relay.
178	521250	Electrical System	Tail Lights, Cab Fwd	BK4 Relay Normally closed contact is shorted	Replace relay.
178	521266	Electrical System	Spare	BK11 Relay coil open or not present	Check chassis module for missing relay. Replace relay.
178	521266	Electrical System	Spare	BK11 Relay Coil shorted or failed relay driver	Replace relay.
178	521266	Electrical System	Spare	BK11 Relay Normally Open contact is open	Replace relay.
178	521266	Electrical System	Spare	BK11 Relay Normally Closed contact is open	Replace relay.
178	521266	Electrical System	Spare	BK11 Relay coil is not receiving power	Contact Dealer.
178	521266	Electrical System	Spare	BK11 Relay Normally open contact is shorted	Replace relay.

REFERENCE

SA	Fault Codes		Telltale	Short Description	Full Fault Description	Recommended Fix/Check Message
	SPN	FMI				
178	521266	7	Electrical System	Spare	BK11 Relay Normally closed contact is shorted	Replace relay.
178	521274	1	Electrical System	Windshield washer	BK12 Relay coil open or not present	Check chassis module for missing relay. Replace relay.
178	521274	2	Electrical System	Windshield washer	BK12 Relay Coil shorted or failed relay driver	Replace relay.
178	521274	3	Electrical System	Windshield washer	BK12 Relay Normally Open contact is open	Replace relay.
178	521274	4	Electrical System	Windshield washer	BK12 Relay Normally Closed contact is open	Replace relay.
178	521274	5	Electrical System	Windshield washer	BK12 Relay coil is not receiving power	Contact Dealer.
178	521274	6	Electrical System	Windshield washer	BK12 Relay Normally open contact is shorted	Replace relay.
178	521274	7	Electrical System	Windshield washer	BK12 Relay Normally closed contact is shorted	Replace relay.
178	521315	1	Electrical System	Brake Lights, Cab Fwd	BF1 Fuse Blown	Replace blown fuse in chassis relay module.
178	521315	2	Electrical System	Brake Lights, Cab Fwd	BF1 Fuse Not Powered	Contact Dealer.
178	521315	3	Electrical System	Brake Lights, Cab Fwd	BF1 Fuse Not Used	Install fuse in chassis relay module.
178	521318	1	Electrical System	Tail Lights, Cab Fwd	BF2 Fuse Blown	Replace blown fuse in chassis relay module.
178	521318	2	Electrical System	Tail Lights, Cab Fwd	BF2 Fuse Not Powered	Contact Dealer.
178	521318	3	Electrical System	Tail Lights, Cab Fwd	BF2 Fuse Not Used	Install fuse in chassis relay module.
178	521321	1	Electrical System	Wiper, Cab Fwd	BF3 Fuse Blown	Replace blown fuse in chassis relay module.
178	521321	2	Electrical System	Wiper, Cab Fwd	BF3 Fuse Not Powered	Contact Dealer.

REFERENCE

Fault Codes			Telltale	Short Description	Full Fault Description	Recommended Fix/Check Message
SA	SPN	FMI				
178	521321	3	Electrical System	Wiper, Cab Fwd	BF3 Fuse Not Used	Install fuse in chassis relay module.
178	521324	1	Electrical System	High Beam Lights, EF	BF4 Fuse Blown	Replace blown fuse in chassis relay module.
178	521324	2	Electrical System	High Beam Lights, EF	BF4 Fuse Not Powered	Contact Dealer.
178	521324	3	Electrical System	High Beam Lights, EF	BF4 Fuse Not Used	Install fuse in chassis relay module.
178	521327	1	Electrical System	Wiper, EF	BF5 Fuse Blown	Replace blown fuse in chassis relay module.
178	521327	2	Electrical System	Wiper, EF	BF5 Fuse Not Powered	Contact Dealer.
178	521327	3	Electrical System	Wiper, EF	BF5 Fuse Not Used	Install fuse in chassis relay module.
178	521330	1	Electrical System	Left Turn Signal	BF6 Fuse Blown	Replace blown fuse in chassis relay module.
178	521330	2	Electrical System	Left Turn Signal	BF6 Fuse Not Powered	Contact Dealer.
178	521330	3	Electrical System	Left Turn Signal	BF6 Fuse Not Used	Install fuse in chassis relay module.
178	521333	1	Electrical System	Right Turn Signal	BF7 Fuse Blown	Replace blown fuse in chassis relay module.
178	521333	2	Electrical System	Right Turn Signal	BF7 Fuse Not Powered	Contact Dealer.
178	521333	3	Electrical System	Right Turn Signal	BF7 Fuse Not Used	Install fuse in chassis relay module.
178	521336	1	Electrical System	Low Beam Lights, EF	BF8 Fuse Blown	Replace blown fuse in chassis relay module.
178	521336	2	Electrical System	Low Beam Lights, EF	BF8 Fuse Not Powered	Contact Dealer.
178	521336	3	Electrical System	Low Beam Lights, EF	BF8 Fuse Not Used	Install fuse in chassis relay module.

REFERENCE

SA	Fault Codes		Telltale	Short Description	Full Fault Description	Recommended Fix/Check Message
	SPN	FMI				
178	521461	1	Electrical System	Chassis Relay Module	Error - Module, Chassis Relay	Contact Dealer.
178	521462	1	Electrical System	Chassis Relay Module	Error - Module, Chassis Relay	Contact Dealer.
178	521463	1	Electrical System	Chassis Relay Module	Error - Module, Chassis Relay	Contact Dealer.
178	521464	1	Electrical System	Chassis Relay Module	Error - Module, Chassis Relay	Contact Dealer.
178	521465	1	Electrical System	Chassis Relay Module	Error - Module, Chassis Relay	Contact Dealer.
178	521466	1	Electrical System	Chassis Relay Module	Error - Module, Chassis Relay	Contact Dealer.
178	521467	1	Electrical System	Chassis Relay Module	Error - Module, Chassis Relay	Contact Dealer.
178	521468	1	Electrical System	Chassis Relay Module	Error - Module, Chassis Relay	Contact Dealer.
178	521469	1	Electrical System	Chassis Relay Module	Error - Module, Chassis Relay	Contact Dealer.
178	521470	1	Electrical System	Chassis Relay Module	Error - Module, Chassis Relay	Contact Dealer.
178	521471	1	Electrical System	Chassis Relay Module	Error - Module, Chassis Relay	Contact Dealer.
178	521472	1	Electrical System	Chassis Relay Module	Error - Module, Chassis Relay	Contact Dealer.
178	521473	1	Electrical System	Chassis Relay Module	Error - Module, Chassis Relay	Contact Dealer.
190	524101	12	Electrical System	Console ROM CRC failed	Power up ROM CRC check failed	Contact Dealer.
190	524102	12	Electrical System	Console memory failed	Power up memory test failed	Contact Dealer.
190	524103	12	Electrical System	Console EEPROM read	Error reading the boot block EEPROM block	Contact Dealer.

REFERENCE

Fault Codes		Telltale	Short Description	Full Fault Description	Recommended Fix/Check Message
SA	SPN				
190	444	Electrical System	Console 12 V Low	The +12 V input is below the minimum operation voltage	Contact Dealer.
190	1043	Electrical System	Console 2.5 V Low	Failure of the 2.5 V A/D converter reference voltage.	Check console wiring for damage. Contact Dealer.
190	3509	Electrical System	Console 5 V Low	The 5 V internal voltage has fallen below 4.5 V.	Check console wiring for damage. Contact Dealer.
190	524260	Electrical System	Console EEPROM write	Error writing value to the console EEPROM.	Contact Dealer.
190	524262	Electrical System	Console primary CRC	Parameter primary table CRC failure.	Contact Dealer.
190	524263	Electrical System	Console redundant CRC	Parameter redundant table CRC failure.	Contact Dealer.
190	524264	Electrical System	Console config reading	Error reading a configuration parameter.	Contact Dealer.
190	2662	Electrical System	Throttle Voltage High	Throttle input has a voltage too high.	Check console wiring for damage. Contact Dealer.
190	2662	Electrical System	Throttle Voltage Low	Throttle input has a voltage too low	Check console wiring for damage. Contact Dealer.
190	2662	Electrical System	Console throttle input	Throttle inputs failed the plausibility check.	Contact Dealer.
190	2662	Electrical System	Console throttle > 0	The throttle was out of neutral when powering up.	Contact Dealer.
190	524129	Electrical System	GSL Handle Offline	Communications lost with the GSL Handle.	Contact Dealer.
190	524130	Electrical System	GSL Button Stuck	There is a stuck button on the handle at power up.	Check GSL switches for failure or binding. Contact Dealer.
190	524131	Electrical System	Console Button Stuck	There is a stuck button on the console at power up.	Check console switches for failure or binding. Contact Dealer.
190	524117	Electrical System	Console button reading	There was an error reading the serial data for the console buttons.	Contact Dealer.

REFERENCE

Fault Codes			Telltale	Short Description	Full Fault Description	Recommended Fix/Check Message
SA	SPN	FMI				
190	524118	31	Electrical System	Console button low	The LOW state test for control panel buttons 4-8 & HeaderReverse failed.	Includes deck shift, DWA up/down and header reverse buttons. Contact Dealer.
190	524119	31	Electrical System	Console button high	The HIGH state test for control panel buttons 4-8 & HeaderReverse failed	Includes deck shift, DWA up/down and header reverse buttons. Contact Dealer.
190	524221	31	Electrical System	GSL button low state	A handle button failed its LOW state check.	Contact Dealer.
190	524222	31	Electrical System	GSL button high state	A handle button failed its HIGH state check.	Contact Dealer.
190	524223	31	Electrical System	GSL scroll encoder	There was a serial data transfer error with the scroll wheel encoders.	Contact Dealer.
190	524224	31	Electrical System	GSL scroll data	The scroll wheel data was read, but there was an error reading a portion of data.	Contact Dealer.
190	524225	31	Electrical System	GSL scroll SPI read	There was a SPI transfer failure while reading the scroll wheel encoders.	Contact Dealer.
190	524265	6	Electrical System	Horn Current High	The horn output is drawing more than 6A.	Contact Dealer.
190	524266	6	Electrical System	Console on-relay >2.5A	The battery on-relay coil is drawing more than 2.5A	Contact Dealer.
190	524267	6	Electrical System	Console off-relay>2.5A	The battery off relay coil is drawing more than 2.5A	Contact Dealer.
190	521392	3	Electrical System	Left Turn Signal	Switch Error	Check switch for damage or binding. Contact Dealer.
190	521392	4	Electrical System	Left Turn Signal	CAN Error	Contact Dealer.
190	521393	3	Electrical System	Right Turn Signal	Switch Error	Check switch for damage or binding. Contact Dealer.
190	521393	4	Electrical System	Right Turn Signal	CAN Error	Contact Dealer.

REFERENCE

Fault Codes		Telltale	Short Description	Full Fault Description	Recommended Fix/Check Message
SA	SPN				
190	521394	Electrical System	Hazard	Switch Error	Check switch for damage or binding. Contact Dealer.
190	521394	Electrical System	Hazard	CAN Error	Contact Dealer.
190	521395	Electrical System	DWA/Swath Roller Up	Switch Error	Check switch for damage or binding. Contact Dealer.
190	521395	Electrical System	DWA/Swath Roller Up	CAN Error	Contact Dealer.
190	521396	Electrical System	DWA/Swath Roller Dn	Switch Error	Check switch for damage or binding. Contact Dealer.
190	521396	Electrical System	DWA/Swath Roller Dn	CAN Error	Contact Dealer.
190	521397	Electrical System	Deck Shift Right	Switch Error	Check switch for damage or binding. Contact Dealer.
190	521397	Electrical System	Deck Shift Right	CAN Error	Contact Dealer.
190	521398	Electrical System	Deck Shift Center	Switch Error	Check switch for damage or binding. Contact Dealer.
190	521398	Electrical System	Deck Shift Center	CAN Error	Contact Dealer.
190	521399	Electrical System	Deck Shift Left	Switch Error	Check switch for damage or binding. Contact Dealer.
190	521399	Electrical System	Deck Shift Left	CAN Error	Contact Dealer.
190	521400	Electrical System	Draper Speed Decrease	Switch Error	Check switch for damage or binding. Contact Dealer.
190	521400	Electrical System	Draper Speed Decrease	CAN Error	Contact Dealer.
190	521401	Electrical System	Draper Speed Increase	Switch Error	Check switch for damage or binding. Contact Dealer.
190	521401	Electrical System	Draper Speed Increase	CAN Error	Contact Dealer.

REFERENCE

Fault Codes		Telltale	Short Description	Full Fault Description	Recommended Fix/Check Message
SA	SPN				
190	521402	Electrical System	Road Lights	Switch Error	Check switch for damage or binding. Contact Dealer.
190	521402	Electrical System	Road Lights	CAN Error	Contact Dealer.
190	521403	Electrical System	High Beam	Switch Error	Check switch for damage or binding. Contact Dealer.
190	521403	Electrical System	High Beam	CAN Error	Contact Dealer.
190	521404	Electrical System	F1 Button	Switch Error	Check switch for damage or binding. Contact Dealer.
190	521404	Electrical System	F1 Button	CAN Error	Contact Dealer.
190	521405	Electrical System	Beacons	Switch Error	Check switch for damage or binding. Contact Dealer.
190	521405	Electrical System	Beacons	CAN Error	Contact Dealer.
190	521406	Electrical System	Clearance Lights	Switch Error	Check switch for damage or binding. Contact Dealer.
190	521406	Electrical System	Clearance Lights	CAN Error	Contact Dealer.
190	521407	Electrical System	Wiper EF	Switch Error	Check switch for damage or binding. Contact Dealer.
190	521407	Electrical System	Wiper EF	CAN Error	Contact Dealer.
190	521408	Electrical System	Washer	Switch Error	Check switch for damage or binding. Contact Dealer.
190	521408	Electrical System	Washer	CAN Error	Contact Dealer.
190	521409	Electrical System	Wiper CF	Switch Error	Check switch for damage or binding. Contact Dealer.
190	521409	Electrical System	Wiper CF	CAN Error	Contact Dealer.

REFERENCE

Fault Codes		Telltale	Short Description	Full Fault Description	Recommended Fix/Check Message
SA	SPN				
190	521410	Electrical System	Field Lights	Switch Error	Check switch for damage or binding. Contact Dealer.
190	521410	Electrical System	Field Lights	CAN Error	Contact Dealer.
190	521411	Electrical System	F2 Button	Switch Error	Check switch for damage or binding. Contact Dealer.
190	521411	Electrical System	F2 Button	CAN Error	Contact Dealer.
190	521412	Electrical System	AC Fan Spd Decrease	Switch Error	Check switch for damage or binding. Contact Dealer.
190	521412	Electrical System	AC Fan Spd Decrease	CAN Error	Contact Dealer.
190	521413	Electrical System	AC Fan Spd Increase	Switch Error	Check switch for damage or binding. Contact Dealer.
190	521413	Electrical System	AC Fan Spd Increase	CAN Error	Contact Dealer.
190	521414	Electrical System	AC Recirc	Switch Error	Check switch for damage or binding. Contact Dealer.
190	521414	Electrical System	AC Recirc	CAN Error	Contact Dealer.
190	521415	Electrical System	F3 Button	Switch Error	Check switch for damage or binding. Contact Dealer.
190	521415	Electrical System	F3 Button	CAN Error	Contact Dealer.
190	521416	Electrical System	F4 Button	Switch Error	Check switch for damage or binding. Contact Dealer.
190	521416	Electrical System	F4 Button	CAN Error	Contact Dealer.
190	521417	Electrical System	AC On/Off	Switch Error	Check switch for damage or binding. Contact Dealer.
190	521417	Electrical System	AC On/Off	CAN Error	Contact Dealer.

REFERENCE

SA	Fault Codes		Telltale	Short Description	Full Fault Description	Recommended Fix/Check Message
	SPN	FMI				
190	521418	3	Electrical System	AC Defrost	Switch Error	Check switch for damage or binding. Contact Dealer.
190	521418	4	Electrical System	AC Defrost	CAN Error	Contact Dealer.
190	521419	3	Electrical System	AC Auto Fan Spd	Switch Error	Check switch for damage or binding. Contact Dealer.
190	521419	4	Electrical System	AC Auto Fan Spd	CAN Error	Contact Dealer.
190	521420	3	Electrical System	AC Cold	Switch Error	Check switch for damage or binding. Contact Dealer.
190	521420	4	Electrical System	AC Cold	CAN Error	Contact Dealer.
190	521421	3	Electrical System	AC Hot	Switch Error	Check switch for damage or binding. Contact Dealer.
190	521421	4	Electrical System	AC Hot	CAN Error	Contact Dealer.
190	521422	3	Electrical System	Horn	Switch Error	Check switch for damage or binding. Contact Dealer.
190	521422	4	Electrical System	Horn	CAN Error	Contact Dealer.
190	521423	3	Electrical System	EEC Button	Switch Error	Check switch for damage or binding. Contact Dealer.
190	521423	4	Electrical System	EEC Button	CAN Error	Contact Dealer.
190	521424	3	Electrical System	F5 Button	Switch Error	Check switch for damage or binding. Contact Dealer.
190	521424	4	Electrical System	F5 Button	CAN Error	Contact Dealer.
190	521425	3	Electrical System	F6 Button	Switch Error	Check switch for damage or binding. Contact Dealer.
190	521425	4	Electrical System	F6 Button	CAN Error	Contact Dealer.

REFERENCE

Fault Codes		Telltale	Short Description	Full Fault Description	Recommended Fix/Check Message
SA	SPN				
190	521426	Electrical System	Header Stop NC	Switch Error	Check switch for damage or binding. Contact Dealer.
190	521426	Electrical System	Header Stop NC	CAN Error	Contact Dealer.
190	521427	Electrical System	Header Reverse	Switch Error	Check switch for damage or binding. Contact Dealer.
190	521427	Electrical System	Header Reverse	CAN Error	Contact Dealer.
190	521429	Electrical System	Operator Present	Switch Error	Check switch for damage or binding. Contact Dealer.
190	521429	Electrical System	Operator Present	CAN Error	Contact Dealer.
190	521433	Electrical System	Door Switches	Switch Error	Check switch for damage or binding. Contact Dealer.
190	521433	Electrical System	Door Switches	CAN Error	Contact Dealer.
190	521434	Electrical System	Throttle	Switch Error	Check switch for damage or binding. Contact Dealer.
190	521434	Electrical System	Throttle	CAN Error	Contact Dealer.
190	521435	Electrical System	Batt Disc. Close	Switch Error	Check switch for damage or binding. Contact Dealer.
190	521435	Electrical System	Batt Disc. Close	CAN Error	Contact Dealer.
190	521436	Electrical System	Horn	Switch Error	Check switch for damage or binding. Contact Dealer.
190	521436	Electrical System	Horn	CAN Error	Contact Dealer.
190	521438	Electrical System	AutoSteer Engage	Switch Error	Check switch for damage or binding. Contact Dealer.
190	521438	Electrical System	AutoSteer Engage	CAN Error	Contact Dealer.

REFERENCE

SA	Fault Codes		Telltale	Short Description	Full Fault Description	Recommended Fix/Check Message
	SPN	FMI				
190	521439	3	Electrical System	A Button	Switch Error	Check switch for damage or binding. Contact Dealer.
190	521439	4	Electrical System	A Button	CAN Error	Contact Dealer.
190	521440	3	Electrical System	B Button	Switch Error	Check switch for damage or binding. Contact Dealer.
190	521440	4	Electrical System	B Button	CAN Error	Contact Dealer.
190	521441	3	Electrical System	C Button	Switch Error	Check switch for damage or binding. Contact Dealer.
190	521441	4	Electrical System	C Button	CAN Error	Contact Dealer.
190	521442	3	Electrical System	Select	Switch Error	Check switch for damage or binding. Contact Dealer.
190	521442	4	Electrical System	Select	CAN Error	Contact Dealer.
190	521443	3	Electrical System	Escape	Switch Error	Check switch for damage or binding. Contact Dealer.
190	521443	4	Electrical System	Escape	CAN Error	Contact Dealer.
190	521444	3	Electrical System	Autosteer	Switch Error	Check switch for damage or binding. Contact Dealer.
190	521444	4	Electrical System	Autosteer	CAN Error	Contact Dealer.
190	521445	3	Electrical System	Tilt Extend	Switch Error	Check switch for damage or binding. Contact Dealer.
190	521445	4	Electrical System	Tilt Extend	CAN Error	Contact Dealer.
190	521446	3	Electrical System	Tilt Retract	Switch Error	Check switch for damage or binding. Contact Dealer.
190	521446	4	Electrical System	Tilt Retract	CAN Error	Contact Dealer.

REFERENCE

Fault Codes		Telltale	Short Description	Full Fault Description	Recommended Fix/Check Message
SA	SPN				
190	521447	Electrical System	Header Raise 1	Switch Error	Check switch for damage or binding. Contact Dealer.
190	521447	Electrical System	Header Raise 1	CAN Error	Contact Dealer.
190	521448	Electrical System	Header Raise 2	Switch Error	Check switch for damage or binding. Contact Dealer.
190	521448	Electrical System	Header Raise 2	CAN Error	Contact Dealer.
190	521449	Electrical System	Header Lower 1	Switch Error	Check switch for damage or binding. Contact Dealer.
190	521449	Electrical System	Header Lower 1	CAN Error	Contact Dealer.
190	521450	Electrical System	Header Lower 2	Switch Error	Check switch for damage or binding. Contact Dealer.
190	521450	Electrical System	Header Lower 2	CAN Error	Contact Dealer.
190	521430	Electrical System	Keyswitch - Ignition	Switch Error	Check switch for damage or binding. Contact Dealer.
190	521430	Electrical System	Keyswitch - Ignition	CAN Error	Contact Dealer.
190	521431	Electrical System	Keyswitch - Accessory	Switch Error	Check switch for damage or binding. Contact Dealer.
190	521431	Electrical System	Keyswitch - Accessory	CAN Error	Contact Dealer.
190	521432	Electrical System	Keyswitch - Crank	Switch Error	Check switch for damage or binding. Contact Dealer.
190	521432	Electrical System	Keyswitch - Crank	CAN Error	Contact Dealer.
190	521451	Electrical System	Reel/Knf Spd -	Switch Error	Check switch for damage or binding. Contact Dealer.
190	521451	Electrical System	Reel/Knf Spd -	CAN Error	Contact Dealer.

REFERENCE

Fault Codes		Telltale	Short Description	Full Fault Description	Recommended Fix/Check Message
SA	SPN				
190	521452	Electrical System	Reel/Knf Spd +	Switch Error	Check switch for damage or binding. Contact Dealer.
190	521452	Electrical System	Reel/Knf Spd +	CAN Error	Contact Dealer.
190	521453	Electrical System	Reel Fore	Switch Error	Check switch for damage or binding. Contact Dealer.
190	521453	Electrical System	Reel Fore	CAN Error	Contact Dealer.
190	521454	Electrical System	Reel Aft	Switch Error	Check switch for damage or binding. Contact Dealer.
190	521454	Electrical System	Reel Aft	CAN Error	Contact Dealer.
190	521455	Electrical System	Reel Raise	Switch Error	Check switch for damage or binding. Contact Dealer.
190	521455	Electrical System	Reel Raise	CAN Error	Contact Dealer.
190	521456	Electrical System	Reel Lower	Switch Error	Check switch for damage or binding. Contact Dealer.
190	521456	Electrical System	Reel Lower	CAN Error	Contact Dealer.
190	521457	Electrical System	GSL Shift Switch	Switch Error	Check switch for damage or binding. Contact Dealer.
190	521457	Electrical System	GSL Shift Switch	CAN Error	Contact Dealer.
190	521459	Electrical System	Wheel Position	Switch Error	Check switch for damage or binding. Contact Dealer.
190	521459	Electrical System	Wheel Position	CAN Error	Contact Dealer.

REFERENCE

8.4 Engine Fault Codes

Example: Harvest Performance Tracker (HPT) displays the Fault Code 629S 16F 28C

- 629S - S represents the J1939 SPN column. Locate code 629 in that column.
- 12F - F represents the FMI column. Locate code 12 in that column.
- 28C - C is occurrences, 28 is the quantity.
- J1939 SPN description - Controller 1. The Cummins description of this is engine control module critical internal failure - Bad intelligent device or component
- The Cummins Dealer will request the fault code that corresponds with the number that you have located in the J1939 SPN column.

J1939 SPN	J1939 FMI	Telltale	Lamp	Cummins Fault Code	J1939_SPN Description	Detail
27	4	Check Engine	Amber	2272	Engine Exhaust Gas	EGR Valve Position Circuit - Voltage below normal, or shorted to low source
51	3	Check Engine	None	6497	Engine Intake Throttle Actuator Position Sensor Circuit	Engine Intake Throttle Actuator Position Sensor Circuit - Voltage above normal, or shorted to high source
51	4	Check Engine	None	6498	Engine Intake Throttle Actuator Position Sensor Circuit	Engine Intake Throttle Actuator Position Sensor Circuit - Voltage above normal, or shorted to low source
81	16	Check Engine	Amber	2754	Engine Diesel Particulate Filter Intake Pressure	Engine Diesel Particulate Filter Intake Pressure - Data Valid But Above Normal Operating range - Moderately Severe Level
84	2	Check Engine	Amber	241	Wheel-Based Vehicle Speed	Wheel-Based Vehicle Speed - Data is erratic, intermittent, or incorrect
84	10	Check Engine	Amber	242	Wheel-Based Vehicle Speed	Wheel-Based Vehicle Speed Sensor Circuit tampering has been detected - Abnormal rate of change
84	19	Check Engine	Amber	3525	Wheel-Based Vehicle Speed	Wheel-Based Vehicle Speed - Received network data in error
91	0	Stop Engine	Red	148	Accelerator Pedal Position 1	Accelerator Pedal or Lever Position Sensor 1 - Data valid but above normal operational range - Most Severe Level
91	1	Stop Engine	Red	147	Accelerator Pedal Position 1	Accelerator Pedal or Lever Position 1 Sensor Circuit Frequency - Data valid but below normal operating range
91	2	Stop Engine	Red	1242	Accelerator Pedal Position 1	Accelerator Pedal or Lever Position Sensor 1 - Data is erratic, intermittent, or incorrect

REFERENCE

J1939 SPN	J1939 FMI	Telltale	Lamp	Cummins Fault Code	J1939_SPN Description	Detail
91	3	Check Engine	Amber	1358	Accelerator Pedal Position 1	Accelerator Pedal or Lever Position Sensor 1 Circuit - Voltage above normal, or shorted to high source
91	4	Check Engine	Amber	1359	Accelerator Pedal Position 1	Accelerator Pedal or Lever Position Sensor 1 Circuit - Voltage below normal, or shorted to low source
91	9	Stop Engine	Red	3326	Accelerator Pedal Position 1	SAE J1939 Multiplexed Accelerator Pedal or Lever Sensor System - Abnormal update rate
91	19	Stop Engine	Red	1515	Accelerator Pedal Position 1	SAE J1939 Multiplexed Accelerator Pedal or Lever Sensor System - Received network data in error
94	3	Check Engine	Amber	546	Engine Fuel Delivery Pressure	Fuel Delivery Pressure Sensor Circuit - Voltage above normal, or shorted to high source
94	4	Check Engine	Amber	547	Engine Fuel Delivery Pressure	Fuel Delivery Pressure Sensor Circuit - Voltage below normal, or shorted to low source
95	16	Check Engine	Amber	2372	Engine Fuel Filter Differential Pressure	Fuel Filter Differential Pressure - Data valid but above normal operating range - Moderately Severe Level
97	3	Check Engine	Amber	428	Water In Fuel Indicator	Water in Fuel Indicator Sensor Circuit - Voltage above normal, or shorted to high source
97	4	Check Engine	Amber	429	Water In Fuel Indicator	Water in Fuel Indicator Sensor Circuit - Voltage below normal, or shorted to low source
97	15	Water in Fuel	Amber (Blinking)	418	Water In Fuel Indicator	Water in Fuel Indicator - Data valid but above normal operating range - Least Severe Level
97	16	Water in Fuel	Amber	1852	Water In Fuel Indicator	Water in Fuel Indicator - Data valid but above normal operating range - Moderately Severe Level
100	1	Eng Oil Press	Red	415	Engine Oil Pressure	Engine Oil Rifle Pressure - Data valid but below normal operational range - Most Severe Level
100	2	Check Engine	Amber	435	Engine Oil Pressure	Engine Oil Rifle Pressure - Data is erratic, intermittent, or incorrect
100	3	Check Engine	Amber	135	Engine Oil Pressure	Engine Oil Rifle Pressure 1 Sensor Circuit - Voltage above normal, or shorted to high source

REFERENCE

J1939 SPN	J1939 FMI	Telltale	Lamp	Cummins Fault Code	J1939_SPN Description	Detail
100	4	Check Engine	Amber	141	Engine Oil Pressure	Engine Oil Rifle Pressure 1 Sensor Circuit - Voltage below normal, or shorted to low source
100	18	Check Engine	Amber	143	Engine Oil Pressure	Engine Oil Rifle Pressure - Data valid but above normal operating range - Moderately Severe Level
101	0	Stop Engine	Red	556	Engine Crankcase Pressure	Crankcase Pressure - Data valid but above normal operational range - Most Severe Level
101	2	Check Engine	Amber	1942	Engine Crankcase Pressure	Crankcase Pressure - Data is erratic, intermittent, or incorrect
101	3	Check Engine	Amber	1843	Engine Crankcase Pressure	Crankcase Pressure Circuit - Voltage above normal, or shorted to high source
101	4	Check Engine	Amber	1844	Engine Crankcase Pressure	Crankcase Pressure Circuit - Voltage below normal, or shorted to low source
101	15	Check Engine	Amber (Blinking)	1974	Engine Crankcase Pressure	Crankcase Pressure - Data valid but above normal operating range - Least Severe Level
101	16	Check Engine	Amber	555	Engine Crankcase Pressure	Crankcase Pressure - Data valid but above normal operating range - Moderately Severe Level
102	3	Check Engine	Amber	122	Engine Intake Manifold #1 Pressure	Intake Manifold 1 Pressure Sensor Circuit - Voltage above normal, or shorted to high source
102	4	Check Engine	Amber	123	Engine Intake Manifold #1 Pressure	Intake Manifold 1 Pressure Sensor Circuit - Voltage below normal, or shorted to low source
102	16	Check Engine	Amber	124	Engine Intake Manifold #1	Intake Manifold 1 Pressure - Data valid but above normal operating range - Moderately Severe Level
103	15	Check Engine	None	2288	Engine Turbocharger 1 Speed	Turbocharger 1 Speed - Data valid but above normal operating range - Least Severe Level
103	16	Check Engine	Amber	595	Engine Turbocharger 1 Speed	Turbocharger 1 Speed - Data valid but above normal operating range - Moderately Severe Level
103	18	Check Engine	Amber	687	Engine Turbocharger 1 Speed	Turbocharger 1 Speed - Data valid but below normal operating range - Moderately Severe Level
105	0	Check Engine	Red	155	Engine Intake Manifold 1	Intake Manifold 1 Temperature - Data valid but above normal operational range - Most Severe Level

REFERENCE

J1939 SPN	J1939 FMI	Telltale	Lamp	Cummins Fault Code	J1939_SPN Description	Detail
105	3	Check Engine	Amber	153	Engine Intake Manifold 1	Intake Manifold 1 Temperature Sensor Circuit - Voltage above normal, or shorted to high source
105	4	Check Engine	Amber	154	Engine Intake Manifold 1	Intake Manifold 1 Temperature Sensor Circuit - Voltage below normal, or shorted to low source
105	15	Check Engine	None	2964	Engine Intake Manifold #1	Intake Manifold 1 Temperature - Data valid but above normal operating range - Least Severe Level
105	16	Check Engine	Amber	488	Engine Intake Manifold	Intake Manifold 1 Temperature - Data valid but above normal operating range - Moderately Severe Level
107	15	Eng Air Filter	Amber	5576	Engine Air Filter 1 Differential Pressure	Engine Air Filter Differential Pressure - Data valid but above normal operating range - Least Severe Level
107	16	Eng Air Filter	Amber	3341	Engine Air Filter 1 Differential Pressure	Engine Air Filter Differential Pressure - Data valid but above normal operating range - Moderately Severe Level
108	3	Check Engine	Amber	221	Barometric Pressure	Barometric Pressure Sensor Circuit - Voltage above normal, or shorted to high source
108	4	Check Engine	Amber	222	Barometric Pressure	Barometric Pressure Sensor Circuit - Voltage above normal, or shorted to low source
110	0	Eng coolant temp	Red	151	Engine Coolant Temperature	Engine Coolant Temperature - Data valid but above normal operational range - Most Severe Level
110	3	Check Engine	Amber	144	Engine Coolant Temperature	Engine Coolant Temperature 1 Sensor Circuit - Voltage above normal, or shorted to high source
110	4	Check Engine	Amber	145	Engine Coolant Temperature	Engine Coolant Temperature 1 Sensor Circuit - Voltage below normal, or shorted to low source
110	16	Eng coolant temp	Amber	146	Engine Coolant Temperature	Engine Coolant Temperature - Data valid but above normal operating range - Moderately Severe Level
110	31	Check Engine	None	2659	Engine Coolant Temperature	Engine Coolant Temperature - Condition Exists
111	1	Coolant Level	Red	235	Engine Coolant Level	Coolant Level - Data valid but below normal operational range - Most Severe Level

REFERENCE

J1939 SPN	J1939 FMI	Telltale	Lamp	Cummins Fault Code	J1939_SPN Description	Detail
111	3	Check Engine	None	6522	Engine Coolant Level	Coolant Level Sensor 1 Circuit - Voltage above normal, or shorted to high source
111	4	Check Engine	None	6523	Engine Coolant Level	Coolant Level Sensor 1 Circuit - Voltage below normal, or shorted to low source
111	9	Check Engine	Amber	3613	SAE J1939 Multiplexing PGN Timeout	SAE J1939 Multiplexing PGN Timeout Error - Abnormal update rate
111	17	Coolant Level	Amber (Blinking)	2448	Engine Coolant Level	Coolant Level - Data valid but below normal operating range - Least Severe Level
111	18	Coolant Level	Amber	197	Engine Coolant Level	Coolant Level - Data valid but below normal operating range - Moderately Severe Level
111	19	Check Engine	Amber	3614	SAE J1939 Multiplexing PGN Timeout	Coolant Level Sensor - Received Network Data in Error
157	0	Stop Engine	Red	449	Engine Injector Metering Rail 1	Injector Metering Rail 1 Pressure - Data valid but above normal operational range - Most Severe Level
157	3	Check Engine	Amber	451	Engine Injector Metering Rail 1	Injector Metering Rail 1 Pressure Sensor Circuit - Voltage above normal, or shorted to high source
157	4	Check Engine	Amber	452	Engine Injector Metering Rail 1	Injector Metering Rail 1 Pressure Sensor Circuit - Voltage below normal, or shorted to low source
157	16	Check Engine	Amber	553	Engine Injector Metering Rail 1	Injector Metering Rail 1 Pressure - Data valid but above normal operating range - Moderately Severe Level
157	18	Check Engine	Amber	559	Engine Injector Metering Rail 1	Injector Metering Rail 1 Pressure - Data valid but below normal operating range - Moderately Severe Level
168	15	Battery	None	6256	Battery Potential / Power Input 1	Battery 1 Voltage - Data valid but above normal operating range - Moderately Severe Level
168	16	Battery	Amber	442	Battery Potential / Power Input 1	Battery 1 Voltage - Data valid but above normal operating range - Moderately Severe Level
168	17	Battery	None	6257	Battery Potential / Power Input 1	Battery 1 Voltage - Data valid but below normal operating range - Moderately Severe Level

REFERENCE

J1939 SPN	J1939 FMI	Telltale	Lamp	Cummins Fault Code	J1939_SPN Description	Detail
168	18	Check Engine	Amber	249	Battery Potential / Power Input 1	Battery 1 Voltage - Data valid but below normal operating range - Moderately Severe Level
171	3	Check Engine	Amber	256	Ambient Air Temperature	Ambient Air Temperature Sensor 1 Circuit - Voltage above normal, or shorted to high source
171	4	Check Engine	Amber	3531	Ambient Air Temperature	Ambient Air Temperature Sensor 1 Circuit - Voltage below normal, or shorted to low source
171	9	Check Engine	Amber	234	Ambient Air Temperature	Ambient Air Temperature - Abnormal update rate
175	3	Check Engine	None	689	Engine Oil Temperature 1	Engine Oil Temperature Sensor 1 Circuit - Voltage above normal, or shorted to high source
175	4	Check Engine	None	6525	Engine Oil Temperature 1	Engine Oil Temperature Sensor 1 Circuit - Voltage below normal, or shorted to low source
190	0	Stop Engine	Red	234	Engine Speed	Engine Crankshaft Speed/Position - Data valid but above normal operational range - Most Severe Level
190	2	Check Engine	None	2321	Engine Speed	Engine Crankshaft Speed/Position - Data is erratic, intermittent, or incorrect
190	16	Check Engine	Amber	2468	Engine Speed	Engine Crankshaft Speed/Position - Data valid but above normal operational range - Moderately Severe Level
191	9	Check Engine	Amber	3328	Transmission Output Shaft	Transmission Output Shaft Speed - Abnormal update rate
191	16	Check Engine	Amber	349	Transmission Output Shaft	Transmission Output Shaft Speed - Data valid but above normal operational range - Moderately Severe Level
191	18	Check Engine	Amber	489	Transmission Output Shaft	Transmission Output Shaft Speed - Data valid but below normal operational range - Moderately Severe Level
191	19	Check Engine	Amber	3418	Transmission Output Shaft	Transmission Output Shaft Speed - Received Network Data In Error
237	13	Check Engine	Amber	4517	Vehicle Identification Number	Vehicle Identification Number - Out of Calibration
411	2	Check Engine	Amber	1866	Engine Exhaust Gas	Exhaust Gas Recirculation Differential Pressure - Data is erratic, intermittent, or incorrect

REFERENCE

J1939 SPN	J1939 FMI	Telltale	Lamp	Cummins Fault Code	J1939_SPN Description	Detail
411	3	Check Engine	Amber	2273	Engine Exhaust Gas Recirculation 1 Differential Pressure	Exhaust Gas Recirculation Differential Pressure Sensor Circuit - Voltage above normal, or shorted to high source
411	4	Check Engine	Amber	2274	Engine Exhaust Gas Recirculation 1 Differential Pressure	Exhaust Gas Recirculation Differential Pressure Sensor Circuit - Voltage below normal, or shorted to low source
412	3	Check Engine	Amber	2375	Engine Exhaust Gas	Exhaust Gas Recirculation Temperature Sensor Circuit - Voltage above normal, or shorted to high source
412	4	Check Engine	Amber	2376	Engine Exhaust Gas	Exhaust Gas Recirculation Temperature Sensor Circuit - Voltage below normal, or shorted to low source
412	15	Check Engine	None	2961	Engine Exhaust Gas	Exhaust Gas Recirculation Temperature - Data valid but above normal operational range - Least Severe Level
412	16	Check Engine	Amber	2962	Engine Exhaust Gas	Exhaust Gas Recirculation Temperature - Data valid but above normal operational range - Moderately Severe Level
441	3	Check Engine	Amber	293	Auxiliary Temperature 1	Auxiliary Temperature Sensor Input 1 Circuit - Voltage above normal, or shorted to high source
441	4	Check Engine	Amber	294	Auxiliary Temperature 1	Auxiliary Temperature Sensor Input 1 Circuit - Voltage below normal, or shorted to low source
441	14	Check Engine	Amber	6583	Auxiliary Temperature 1	Auxiliary Temperature Sensor Input 1 - Special Instructions
442	3	Check Engine	Amber	3765	Auxiliary Temperature 2	Auxiliary Temperature Sensor Input 2 Circuit - Voltage above normal, or shorted to high source
442	4	Check Engine	Amber	3766	Auxiliary Temperature 2	Auxiliary Temperature Sensor Input 2 Circuit - Voltage below normal, or shorted to low source
558	2	Check Engine	Amber	431	Accelerator Pedal 1 Low Idle Switch	Accelerator Pedal or Lever Idle Validation Switch - Data is erratic, intermittent, or incorrect
558	13	Stop Engine	Red	432	Accelerator Pedal 1 Low Idle Switch	Accelerator Pedal or Lever Idle Validation Switch Circuit - Out of Calibration
558	19	Stop Engine	Red	3527	Accelerator Pedal 1 Low Idle Switch	Accelerator Pedal or Lever Idle Validation Switch - Received Network Data In Error

REFERENCE

J1939 SPN	J1939 FMI	Telltale	Lamp	Cummins Fault Code	J1939_SPN Description	Detail
563	9	Check Engine	Amber	3488	Anti-Lock Braking (ABS) Active	Anti-Lock Braking (ABS) Controller - Abnormal update rate
563	31	Check Engine	None	4215	Anti-Lock Braking (ABS) Active	Anti-Lock Braking (ABS) Active - Condition Exists
611	2	Check Engine	Amber	523	System Diagnostic Code #1	Auxiliary Intermediate (PTO) Speed Switch Validation - Data is erratic, intermittent, or incorrect
612	2	Stop Engine	Red	115	System Diagnostic Code #2	Engine Magnetic Speed/Position Lost Both of Two Signals - Data is erratic, intermittent, or incorrect
625	9	Stop Engine	Red	291	Proprietary Datalink	Proprietary Datalink Error (OEM/ Vehicle Datalink) - Abnormal update rate
629	12	Check Engine	Amber	343	Controller #1	Engine Control Module Warning Internal Hardware Failure - Bad intelligent device or component
630	12	Stop Engine	Red	3697	Engine Control Module Calibration Memory	Engine Control Module Calibration Memory - Bad intelligent device or component
633	31	Check Engine	Amber	2311	Engine Fuel Actuator 1 Control Command	Electronic Fuel Injection Control Valve Circuit - Condition Exists
639	9	Check Engine	Amber	285	J1939 Network #1, Primary Vehicle Network (previously SAE J1939 Data Link)	SAE J1939 Multiplexing PGN Timeout Error - Abnormal update rate
639	13	Check Engine	Amber	286	J1939 Network #1, Primary Vehicle Network (previously SAE J1939 Data Link)	SAE J1939 Multiplexing Configuration Error - Out of Calibration
640	14	Stop Engine	Red	599	Engine External Protection Input	Auxiliary Commanded Dual Output Shutdown - Special Instructions
641	7	Check Engine	Amber	2387	Engine Variable Geometry Turbocharger Actuator #1	VGT Actuator Driver Circuit (Motor) - Mechanical system not responding or out of adjustment
641	9	Check Engine	Amber	1894	Engine Variable Geometry Turbocharger Actuator #1	VGT Actuator Driver Circuit - Abnormal update rate
641	11	Check Engine	Amber	2198	Engine Variable Geometry Turbocharger Actuator #1	VGT Actuator Driver Circuit - Root Cause Not Known
641	12	Stop Engine	Red	2634	Engine Variable Geometry Turbocharger Actuator #1	VGT Actuator Controller - Bad intelligent device or component
641	13	Stop Engine	Red	2449	Engine Variable Geometry Turbocharger Actuator #1	VGT Actuator Controller - Out of Calibration

REFERENCE

J1939 SPN	J1939 FMI	Telltale	Lamp	Cummins Fault Code	J1939_SPN Description	Detail
641	15	Check Engine	None	1976	Engine Variable Geometry Turbocharger Actuator #1	VGT Actuator Driver Over Temperature (Calculated) - Data valid but above normal operational range - Least Severe Level
641	31	Stop Engine	Red	2635	Engine Variable Geometry Turbocharger Actuator #1	VGT Actuator Driver Circuit - Condition exists
647	3	Check Engine	None	6263	Engine Fan Clutch 1 Output Device Driver	Fan Control Circuit - Voltage above normal, or shorted to high source
647	4	Check Engine	None	6264	Engine Fan Clutch 1 Output Device Driver	Fan Control Circuit - Voltage below normal, or shorted to low source
651	5	Check Engine	Amber	322	Engine Injector Cylinder #01	Injector Solenoid Driver Cylinder 1 Circuit - Current below normal or open circuit
652	5	Check Engine	Amber	331	Engine Injector Cylinder #02	Injector Solenoid Driver Cylinder 2 Circuit - Current below normal or open circuit
652	7	Check Engine	Amber	1141	Engine Injector Cylinder #02	Injector Solenoid Driver Cylinder 2 - Mechanical system not responding or out of adjustment
653	5	Check Engine	Amber	324	Engine Injector Cylinder #03	Injector Solenoid Driver Cylinder 3 Circuit - Current below normal or open circuit
653	7	Check Engine	Amber	1142	Engine Injector Cylinder #03	Injector Solenoid Driver Cylinder 3 - Mechanical system not responding or out of adjustment
654	5	Check Engine	Amber	332	Engine Injector Cylinder #04	Injector Solenoid Driver Cylinder 4 Circuit - Current below normal or open circuit
654	7	Check Engine	Amber	1143	Engine Injector Cylinder #04	Injector Solenoid Driver Cylinder 4 - Mechanical system not responding or out of adjustment
655	5	Check Engine	Amber	323	Engine Injector Cylinder #05	Injector Solenoid Driver Cylinder 5 Circuit - Current below normal or open circuit
655	7	Check Engine	Amber	1144	Engine Injector Cylinder #05	Injector Solenoid Driver Cylinder 5 - Mechanical system not responding or out of adjustment
656	5	Check Engine	Amber	325	Engine Injector Cylinder #06	Injector Solenoid Driver Cylinder 6 Circuit - Current below normal or open circuit
656	7	Check Engine	Amber	1145	Engine Injector Cylinder #06	Injector Solenoid Driver Cylinder 6 - Mechanical system not responding or out of adjustment

REFERENCE

J1939 SPN	J1939 FMI	Telltale	Lamp	Cummins Fault Code	J1939_SPN Description	Detail
677	3	Check Engine	Amber	584	Engine Starter Motor Relay	Starter Relay Driver Circuit - Voltage above normal, or shorted to high source
677	4	Check Engine	Amber	585	Engine Starter Motor Relay	Starter Relay Driver Circuit - Voltage below normal, or shorted to low source
697	3	Check Engine	Amber	2557	Auxiliary PWM Driver #1	Auxiliary PWM Driver 1 Circuit - Voltage above normal, or shorted to high source
697	4	Check Engine	Amber	2558	Auxiliary PWM Driver #1	Auxiliary PWM Driver 1 Circuit - Voltage below normal, or shorted to low source
701	14	Stop Engine	Red	4734	Auxiliary I/O #01	Auxiliary Input/Output 1 - Special Instructions
702	3	Check Engine	Amber	527	Auxiliary I/O #02	Auxiliary Input/Output 2 Circuit - Voltage above normal, or shorted to high source
703	3	Check Engine	Amber	529	Auxiliary I/O #03	Auxiliary Input/Output 3 Circuit - Voltage above normal, or shorted to high source
723	2	Check Engine	None	2322	Engine Speed 2	Engine Camshaft Speed/Position Sensor - Data is erratic, intermittent, or incorrect
723	7	Check Engine	Amber	731	Engine Speed 2	Engine Speed/Position Camshaft and Crankshaft Misalignment - Mechanical system not responding or out of adjustment
729	3	Check Engine	None	6556	Engine Intake Air Heater Driver #1	Engine Intake Air Heater 1 Circuit - Voltage above normal, or shorted to high source
729	4	Check Engine	None	6557	Engine Intake Air Heater Driver #1	Engine Intake Air Heater 1 Circuit - Voltage below normal, or shorted to low source
748	9	Check Engine	Amber	3641	Transmission Output Retarder	Transmission Output Retarder - Abnormal update rate
862	3	Check Engine	None	6336	Crankcase Breather Heater Circuit	Crankcase Breather Filter Heater Circuit - Voltage above normal, or shorted to high source
862	4	Check Engine	None	6337	Crankcase Breather Heater Circuit	Crankcase Breather Filter Heater Circuit - Voltage below normal, or shorted to low source
974	3	Stop Engine	Red	133	Remote Accelerator Pedal Position	Remote Accelerator Pedal or Lever Position Sensor 1 Circuit - Voltage above normal, or shorted to high source

REFERENCE

J1939 SPN	J1939 FMI	Telltale	Lamp	Cummins Fault Code	J1939_SPN Description	Detail
974	4	Stop Engine	Red	134	Remote Accelerator Pedal Position	Remote Accelerator Pedal or Lever Position Sensor 1 Circuit - Voltage below normal, or shorted to low source
974	19	Stop Engine	Red	288	Remote Accelerator Pedal Position	SAE J1939 Multiplexing Remote Accelerator Pedal or Lever Position Sensor System - Received network data in error
976	2	Check Engine	None	6563	PTO Governor State	Auxiliary Intermediate (PTO) Speed Switch Validation - Data is erratic, intermittent, or incorrect
1072	3	Check Engine	None	6418	Engine (Compression) Brake Output #1	Engine Brake Actuator Driver 1 Circuit - Voltage above normal, or shorted to high source
1072	4	Check Engine	None	6419	Engine (Compression) Brake Output #1	Engine Brake Actuator Driver 1 Circuit - Voltage below normal, or shorted to low source
1073	3	Check Engine	None	6421	Engine (Compression) Brake Output #2	Engine Brake Actuator Driver Output 2 Circuit - Voltage above normal, or shorted to high source
1073	4	Check Engine	None	6422	Engine (Compression) Brake Output #2	Engine Brake Actuator Driver Output 2 Circuit - Voltage below normal, or shorted to low source
1075	3	Check Engine	None	6258	Engine Electric Lift Pump for Engine Fuel Supply	Electric Lift Pump for Engine Fuel Supply Circuit - Voltage above normal, or shorted to high source
1075	4	Check Engine	None	6259	Engine Electric Lift Pump for Engine Fuel Supply	Electric Lift Pump for Engine Fuel Supply Circuit - Voltage below normal, or shorted to low source
1081	9	Check Engine	Amber	3555	Engine Wait to Start Lamp	Engine Wait to Start Lamp - Abnormal update rate
1172	3	Check Engine	Amber	691	Engine Turbocharger 1 Compressor Intake Temperature	Turbocharger 1 Compressor Intake Temperature Circuit - Voltage above normal, or shorted to high source
1172	4	Check Engine	Amber	692	Engine Turbocharger 1 Compressor Intake Temperature	Turbocharger 1 Compressor Intake Temperature Circuit - Voltage below normal, or shorted to low source
1176	2	Check Engine	Amber	743	Engine Turbocharger 1 Compressor Intake Pressure	Turbocharger 1 Compressor Intake Pressure - Data is erratic, intermittent, or incorrect
1176	3	Check Engine	Amber	741	Engine Turbocharger 1 Compressor Intake Pressure	Turbocharger 1 Compressor Intake Pressure Circuit - Voltage above normal, or shorted to high source

REFERENCE

J1939 SPN	J1939 FMI	Telltale	Lamp	Cummins Fault Code	J1939_SPN Description	Detail
1176	4	Check Engine	Amber	742	Engine Turbocharger 1 Compressor Intake Pressure	Turbocharger 1 Compressor Intake Pressure Circuit - Voltage below normal, or shorted to low source
1194	13	Stop Engine	Red	3298	Anti-theft Encryption Seed Present Indicator	Anti-theft Encryption Seed - Out of Calibration
1209	2	Check Engine	Amber	2554	Engine Exhaust Gas Pressure 1	Exhaust Gas Pressure 1 - Data is erratic, intermittent, or incorrect
1209	3	Check Engine	Amber	2373	Engine Exhaust Gas Pressure 1	Exhaust Gas Pressure Sensor 1 Circuit - Voltage above normal, or shorted to high source
1209	4	Check Engine	Amber	2374	Engine Exhaust Gas Pressure 1	Exhaust Gas Pressure Sensor 1 Circuit - Voltage below normal, or shorted to low source
1231	2	Check Engine	None	3329	J1939 Network #2	J1939 Network #2 - Data is erratic, intermittent, or incorrect
1235	2	Check Engine	None	3331	J1939 Network #3	J1939 Network #3 - Data is erratic, intermittent, or incorrect
1267	3	Check Engine	Amber	338	Idle Shutdown Vehicle Accessories Relay Driver Circuit	Idle Shutdown Vehicle Accessories Relay Driver Circuit - Voltage above normal, or shorted to high source
1267	4	Check Engine	Amber	339	Idle Shutdown Vehicle Accessories Relay Driver Circuit	Idle Shutdown Vehicle Accessories Relay Driver Circuit - Voltage below normal, or shorted to low source
1323	31	Check Engine	Amber	1654	Engine Misfire Cylinder #1	Engine Misfire Cylinder 1 - Condition Exists
1324	31	Check Engine	Amber	1655	Engine Misfire Cylinder #2	Engine Misfire Cylinder 2 - Condition exists
1325	31	Check Engine	Amber	1656	Engine Misfire Cylinder #3	Engine Misfire Cylinder 3 - Condition Exists
1326	31	Check Engine	Amber	1657	Engine Misfire Cylinder #4	Engine Misfire Cylinder 4 - Condition Exists
1327	31	Check Engine	Amber	1658	Engine Misfire Cylinder #5	Engine Misfire Cylinder 5 - Condition Exists
1328	31	Check Engine	Amber	1659	Engine Misfire Cylinder #6	Engine Misfire Cylinder 6 - Condition Exists
1347	3	Check Engine	Amber	272	Engine Fuel Pump Pressurizing Assembly #2	Engine Fuel Pump Pressurizing Assembly 1 Circuit - Voltage above normal, or shorted to high source
1347	4	Check Engine	Amber	271	Engine Fuel Pump Pressurizing Assembly #1	Engine Fuel Pump Pressurizing Assembly 1 Circuit - Voltage below normal, or shorted to low source

REFERENCE

J1939 SPN	J1939 FMI	Telltale	Lamp	Cummins Fault Code	J1939_SPN Description	Detail
1347	7	Check Engine	Amber	281	Engine Fuel Pump Pressurizing Assembly #3	Engine Fuel Pump Pressurizing Assembly 1 - Mechanical system not responding or out of adjustment
1349	3	Check Engine	Amber	483	Engine Injector Metering Rail 2 Pressure	Injector Metering Rail 2 Pressure Sensor Circuit - Voltage above normal, or shorted to high source
1377	2	Check Engine	Amber	497	Engine Synchronization Switch	Multiple Unit Synchronization Switch - Data is erratic, intermittent, or incorrect
1378	31	Check Engine	Amber (Blinking)	649	Engine Oil Change Interval	Engine Oil Change Interval - Condition exists
1387	3	Check Engine	Amber	1539	Auxiliary Pressure #1	Auxiliary Pressure Sensor Input 1 Circuit - Voltage above normal, or shorted to high source
1387	4	Check Engine	Amber	1621	Auxiliary Pressure #1	Auxiliary Pressure Sensor Input 1 Circuit - Voltage below normal, or shorted to low source
1388	3	Check Engine	Amber	297	Auxiliary Pressure #2	Auxiliary Pressure Sensor Input 2 Circuit - Voltage above normal, or shorted to high source
1388	4	Check Engine	Amber	298	Auxiliary Pressure #2	Auxiliary Pressure Sensor Input 2 Circuit - Voltage below normal, or shorted to low source
1388	14	Check Engine	Amber	6584	Auxiliary Pressure #2	Auxiliary Pressure Sensor Input 2 - Special Instructions
1569	31	Check Engine	Amber	3714	Engine Protection Torque Derate	Engine Protection Torque Derate - Condition Exists
1623	9	Check Engine	Amber	3186	Tachograph output shaft speed	Tachograph Output Shaft Speed - Abnormal update rate
1623	13	Check Engine	Amber	5248	Tachograph output shaft speed	Tachograph Output Shaft Speed - Out of Calibration
1623	19	Check Engine	Amber	3213	Tachograph output shaft speed	Tachograph Output Shaft Speed - Received Network Data In Error
1632	14	Check Engine	Amber	2998	Engine Torque Limit Feature	Engine Torque Limit Feature - Special Instructions
1639	0	Check Engine	Amber	4789	Fan Speed	Fan Speed - Data valid but above normal operational range - Most Severe Level
1639	1	Check Engine	Amber	4791	Fan Speed	Fan Speed - Data valid but below normal operational range - Most Severe Level
1639	2	Check Engine	None	6469	Fan Speed	Fan Speed – Data is erratic, intermittent, or Incorrect

REFERENCE

J1939 SPN	J1939 FMI	Telltale	Lamp	Cummins Fault Code	J1939_SPN Description	Detail
1639	15	Check Engine	None	6467	Fan Speed	Fan Speed - Data valid but above normal operational range - Most Severe Level
1639	17	Check Engine	None	6468	Fan Speed	Fan Speed - Data valid but below normal operational range - Most Severe Level
1668	2	Check Engine	None	4437	J1939 Network #4 - Data erratic	J1939 Network #4 - Data is erratic, intermittent, or incorrect
1675	31	Check Engine	None	3737	Engine Starter Mode	Engine Starter Mode Overcrank Protection - Condition Exists
1761	1	DEF	Amber	1673	Aftertreatment 1 Diesel Exhaust Fluid Tank Level	Aftertreatment 1 Diesel Exhaust Fluid Tank Level - Data valid but below normal operational range - Most Severe Level
1761	3	Check Engine	Amber	1669	Aftertreatment 1 Diesel Exhaust Fluid Tank Level	Aftertreatment 1 Diesel Exhaust Fluid Tank Level Sensor Circuit - Voltage above normal, or shorted to high source
1761	4	Check Engine	Amber	1668	Aftertreatment 1 Diesel Exhaust Fluid Tank Level	Aftertreatment 1 Diesel Exhaust Fluid Tank Level Sensor Circuit - Voltage below normal, or shorted to low source
1761	9	Check Engine	Amber	4677	Aftertreatment 1 Diesel Exhaust Fluid Tank Level	SAE J1939 Multiplexing PGN Timeout Error - Abnormal update rate
1761	10	Check Engine	Amber	4769	Aftertreatment 1 Diesel Exhaust Fluid Tank Level	Aftertreatment 1 Diesel Exhaust Fluid Tank Level Sensor - Abnormal Rate of Change
1761	11	Check Engine	None	6562	Aftertreatment 1 Diesel Exhaust Fluid Tank Level	Aftertreatment 1 Diesel Exhaust Fluid Tank Level Sensor - Root Cause Not Known
1761	13	Check Engine	None	6526	Aftertreatment 1 Diesel Exhaust Fluid Tank Temperature	Aftertreatment 1 Diesel Exhaust Fluid Tank Level Sensor - Out of Calibration
1761	17	DEF	Amber (Blinking)	3497	Aftertreatment 1 Diesel Exhaust Fluid Tank Level	Aftertreatment 1 Diesel Exhaust Fluid Tank Level - Data Valid But Below Normal Operating Range - Least Severe Level
1761	18	DEF	Amber (Blinking)	3498	Aftertreatment 1 Diesel Exhaust Fluid Tank Level	Aftertreatment 1 Diesel Exhaust Fluid Tank Level - Data valid but below normal operational range - Moderately Severe Level
2623	3	Check Engine	Amber	1239	Accelerator Pedal #1 Channel 2	Accelerator Pedal or Lever Position Sensor 2 Circuit - Voltage above normal, or shorted to high source

REFERENCE

J1939 SPN	J1939 FMI	Telltale	Lamp	Cummins Fault Code	J1939_SPN Description	Detail
2623	4	Check Engine	Amber	1241	Accelerator Pedal #1 Channel 2	Accelerator Pedal or Lever Position Sensor 2 Circuit - Voltage below normal, or shorted to low source
2630	3	Check Engine	Amber	2571	Engine Charge Air Cooler 1 Outlet Temperature	Engine Charge Air Cooler Outlet Temperature - Voltage above normal, or shorted to high source
2630	4	Check Engine	Amber	2572	Engine Charge Air Cooler 1 Outlet Temperature	Engine Charge Air Cooler Outlet Temperature - Voltage below normal, or shorted to low source
2789	15	Check Engine	None	2346	Engine Turbocharger 1 Calculated Turbine Intake Temperature	Turbocharger Turbine Intake Temperature - Data valid but above normal operational range - Least Severe
2791	5	Check Engine	Amber	2349	Engine Exhaust Gas Recirculation 1 (EGR1) Valve Control	EGR Valve Control Circuit - Current below normal or open circuit
2791	6	Check Engine	Amber	2353	Engine Exhaust Gas Recirculation 1 (EGR1) Valve Control	EGR Valve Control Circuit - Current above normal or grounded circuit
2791	7	Check Engine	None	6555	Engine Exhaust Gas Recirculation 1 (EGR1) Valve Control	EGR Valve Control Circuit - Mechanical system not responding or out of adjustment
2791	13	Check Engine	Amber	1896	Engine Exhaust Gas Recirculation 1 (EGR1) Valve Control	EGR Valve Controller - Out of Calibration
2791	15	Check Engine	Amber	1961	Engine Exhaust Gas Recirculation 1 (EGR1) Valve Control	EGR Valve Control Circuit Over Temperature - Data valid but above normal operational range - Least Severe Level
3031	2	Check Engine	Amber	1679	Aftertreatment 1 Diesel Exhaust Fluid Tank Temperature	Aftertreatment 1 Diesel Exhaust Fluid Tank Temperature - Data is erratic, intermittent, or incorrect
3031	3	Check Engine	Amber	1678	Aftertreatment 1 Diesel Exhaust Fluid Tank Temperature	Aftertreatment 1 Diesel Exhaust Fluid Tank Temperature Sensor - Voltage above normal, or shorted to high source
3031	4	Check Engine	None	6559	Aftertreatment 1 Diesel Exhaust Fluid Tank Temperature	Aftertreatment 1 Diesel Exhaust Fluid Tank Temperature Sensor - Voltage below normal, or shorted to low source
3031	9	Check Engine	Amber	4572	Aftertreatment 1 Diesel Exhaust Fluid Tank Temperature	Aftertreatment 1 Diesel Exhaust Fluid Tank Temperature - Abnormal Update Rate
3031	11	Check Engine	Amber	4737	Aftertreatment 1 Diesel Exhaust Fluid Tank Temperature	Aftertreatment 1 Diesel Exhaust Fluid Tank Temperature - Root Cause Not Known

REFERENCE

J1939 SPN	J1939 FMI	Telltale	Lamp	Cummins Fault Code	J1939_SPN Description	Detail
3031	13	Check Engine	Amber	4731	Aftertreatment 1 Diesel Exhaust Fluid Tank Temperature	Aftertreatment 1 Diesel Exhaust Fluid Tank Temperature Sensor - Out of Calibration
3216	2	Check Engine	Amber	3228	Aftertreatment 1 Intake NOx	Aftertreatment 1 Intake NOx Sensor - Data is erratic, intermittent, or incorrect
3216	4	Check Engine	Amber	1885	Aftertreatment 1 Intake NOx	Aftertreatment 1 Intake NOx Sensor Circuit - Voltage below normal, or shorted to low source
3216	9	Check Engine	Amber	3232	Aftertreatment 1 Intake NOx	Aftertreatment 1 Intake NOx Sensor - Abnormal update rate
3216	10	Check Engine	None	6621	Aftertreatment 1 Intake NOx	Aftertreatment 1 Intake NOx Sensor - Abnormal rate of change
3216	13	Check Engine	Amber	3718	Aftertreatment 1 Intake NOx	Aftertreatment 1 Intake NOx - Out of Calibration
3216	16	Check Engine	Amber	3726	Aftertreatment 1 Intake NOx	Aftertreatment 1 Intake NOx - Data valid but above normal operating range - Moderately Severe Level
3216	20	Check Engine	None	6458	Aftertreatment 1 Intake NOx	Aftertreatment 1 Intake NOx Sensor - Data not Rational - Drifted High
3216	21	Check Engine	None	6459	Aftertreatment 1 Intake NOx	Aftertreatment 1 Intake NOx Sensor - Data not Rational - Drifted High
3218	2	Check Engine	Amber	3682	Aftertreatment 1 Intake Gas Sensor Power Status	Aftertreatment 1 Intake NOx Sensor Power Supply - Data is erratic, intermittent, or incorrect
3226	2	Check Engine	None	6464	Aftertreatment 1 Outlet NOx	Aftertreatment 1 Outlet NOx Sensor - Data not Rational - Drifted High
3226	4	Check Engine	None	6521	Aftertreatment Outlet NOx Sensor Circuits	Aftertreatment Outlet NOx Sensor Circuit- Voltage below normal or shorted to low source
3226	9	Check Engine	Amber	2771	Aftertreatment 1 Outlet NOx	Aftertreatment 1 Outlet NOx Sensor - Abnormal update rate
3226	10	Check Engine	None	6565	Aftertreatment 1 Outlet NOx	Aftertreatment 1 Outlet NOx Sensor - Abnormal rate of change
3226	13	Check Engine	Amber	3717	Aftertreatment 1 Outlet NOx	Aftertreatment 1 Outlet NOx Sensor - Out of Calibration
3226	20	Check Engine	None	6462	Aftertreatment 1 Outlet NOx	Aftertreatment 1 Outlet NOx Sensor - Data not Rational - Drifted High

REFERENCE

J1939 SPN	J1939 FMI	Telltale	Lamp	Cummins Fault Code	J1939_SPN Description	Detail
3226	21	Check Engine	None	6463	Aftertreatment 1 Outlet NOx	Aftertreatment 1 Outlet NOx Sensor - Data not Rational - Drifted High
3228	2	Check Engine	None	6582	Aftertreatment 1 Outlet Gas Sensor Power Status	Aftertreatment 1 Outlet NOx Sensor Power Supply - Data is erratic, intermittent, or incorrect
3242	0	Stop Engine	Red	3311	Aftertreatment 1 Diesel Particulate Filter Intake Gas Temperature	Aftertreatment 1 Diesel Particulate Filter Intake Temperature - Data valid but above normal operation
3242	2	Check Engine	Amber	3318	Aftertreatment 1 Diesel Particulate Filter Intake Gas Temperature	Aftertreatment 1 Diesel Particulate Filter Intake Temperature - Data is erratic, intermittent, or incorrect
3242	3	Check Engine	Amber	3317	Aftertreatment 1 Diesel Particulate Filter Intake Gas Temperature	Aftertreatment 1 Diesel Particulate Filter Intake Temperature Sensor Circuit - Voltage above normal, or shorted to high source
3242	4	Check Engine	Amber	3316	Aftertreatment 1 Diesel Particulate Filter Intake Gas Temperature	Aftertreatment 1 Diesel Particulate Filter Intake Temperature Sensor Circuit - Voltage below normal, or shorted to low source
3242	15	Check Engine	Amber	3254	Aftertreatment 1 Diesel Particulate Filter Intake Gas Temperature	Aftertreatment 1 Diesel Particulate Filter Intake Temperature - Data valid but above normal operating range
3242	16	Stop Engine	Red	3253	Aftertreatment 1 Diesel Particulate Filter Intake Gas Temperature	Aftertreatment 1 Diesel Particulate Filter Intake Temperature - Data valid but above normal operating range
3246	0	Stop Engine	Red	3312	Aftertreatment 1 Diesel Particulate Filter Outlet Gas Temperature	Aftertreatment 1 Diesel Particulate Filter Outlet Temperature - Data valid but above normal operation
3246	2	Check Engine	Amber	3322	Aftertreatment 1 Diesel Particulate Filter Outlet Gas Temperature	Aftertreatment 1 Diesel Particulate Filter Outlet Temperature - Data is erratic, intermittent, or incorrect
3246	3	Check Engine	Amber	3319	Aftertreatment 1 Diesel Particulate Filter Outlet Gas Temperature	Aftertreatment 1 Diesel Particulate Filter Outlet Temperature Sensor Circuit - Voltage above normal, or shorted to high source

REFERENCE

J1939 SPN	J1939 FMI	Telltale	Lamp	Cummins Fault Code	J1939_SPN Description	Detail
3246	4	Check Engine	Amber	3321	Aftertreatment 1 Diesel Particulate Filter Outlet Gas Temperature	Aftertreatment 1 Diesel Particulate Filter Outlet Temperature Sensor Circuit - Voltage below normal, or shorted to low source
3246	15	Check Engine	Amber	3256	Aftertreatment 1 Diesel Particulate Filter Outlet Gas Temperature	Aftertreatment 1 Diesel Particulate Filter Outlet Temperature - Data valid but above normal operating range
3246	16	Stop Engine	Red	3255	Aftertreatment 1 Diesel Particulate Filter Outlet Gas Temperature	Aftertreatment 1 Diesel Particulate Filter Outlet Temperature - Data valid but above normal operating range
3251	0	Stop Engine	Red	1922	Aftertreatment 1 Diesel Particulate Filter Differential Pressure	Aftertreatment Diesel Particulate Filter Differential Pressure - Data valid but above normal operating range
3251	2	Check Engine	Amber	1883	Aftertreatment 1 Diesel Particulate Filter Differential Pressure	Aftertreatment Diesel Particulate Filter Differential Pressure Sensor - Data is erratic, intermittent, or incorrect
3251	3	Check Engine	Amber	1879	Aftertreatment 1 Diesel Particulate Filter Differential Pressure	Aftertreatment Diesel Particulate Filter Differential Pressure Sensor Circuit - Voltage above normal
3251	4	Check Engine	Amber	1881	Aftertreatment 1 Diesel Particulate Filter Differential Pressure	Aftertreatment Diesel Particulate Filter Differential Pressure Sensor Circuit - Voltage below normal
3251	15	Check Engine	None	2639	Aftertreatment 1 Diesel Particulate Filter Differential Pressure	Aftertreatment Diesel Particulate Filter Differential Pressure - Data valid but above normal operating range
3251	16	Check Engine	Amber	1921	Aftertreatment 1 Diesel Particulate Filter Differential Pressure	Aftertreatment Diesel Particulate Filter Differential Pressure - Data valid but above normal operating range
3361	2	Check Engine	Amber	2976	Aftertreatment 1 Diesel Exhaust Fluid DEF Supply Module	Aftertreatment 1 Diesel Exhaust Fluid Supply Module Temperature - Data is erratic, intermittent, or incorrect
3361	3	Check Engine	Amber	3558	Aftertreatment 1 Diesel Exhaust Fluid DEF Supply Module	Aftertreatment 1 Diesel Exhaust Fluid Supply Module - Voltage above normal, or shorted to high source
3361	4	Check Engine	Amber	3559	Aftertreatment 1 Diesel Exhaust Fluid DEF Supply Module	Aftertreatment 1 Diesel Exhaust Fluid Supply Module - Voltage below normal, or shorted to low source

REFERENCE

J1939 SPN	J1939 FMI	Telltale	Lamp	Cummins Fault Code	J1939_SPN Description	Detail
3362	31	Check Engine	Amber	1682	Aftertreatment 1 Diesel Exhaust Fluid Supply Module Input Lines	Aftertreatment 1 Diesel Exhaust Fluid Supply Module Input Lines - Condition Exists
3363	3	Check Engine	None	6479	Aftertreatment 1 Diesel Exhaust Fluid Tank 1 Heater	Aftertreatment 1 Diesel Exhaust Fluid Tank Heater - Voltage above normal, or shorted to high source
3363	4	Check Engine	None	6481	Aftertreatment 1 Diesel Exhaust Fluid Tank 1 Heater	Aftertreatment 1 Diesel Exhaust Fluid Tank Heater - Voltage below normal, or shorted to low source
3363	7	Check Engine	None	6475	Aftertreatment 1 Diesel Exhaust Fluid Tank 1 Heater	Aftertreatment 1 Diesel Exhaust Fluid Tank Heater - Mechanical system not responding or out of adjustment
3363	16	Check Engine	Amber	1713	Aftertreatment 1 Diesel Exhaust Fluid Tank 1 Heater	Aftertreatment 1 Diesel Exhaust Fluid Tank Heater - Data valid but above normal operating range - Moderately Severe Level
3363	18	Check Engine	None	6476	Aftertreatment 1 Diesel Exhaust Fluid Tank 1 Heater	Aftertreatment 1 Diesel Exhaust Fluid Tank Heater - Data valid but below normal operating range - Moderately Severe Level
3364	1	Check Engine	Amber	3866	Aftertreatment 1 Diesel Exhaust Fluid Tank 1 Quality	Aftertreatment Diesel Exhaust Fluid Quality - Data valid but below normal operational range - Most Severe Level
3364	2	Check Engine	Amber	3878	Aftertreatment 1 Diesel Exhaust Fluid Tank 1 Quality	Aftertreatment Diesel Exhaust Fluid Quality - Data is erratic, intermittent, or incorrect
3364	3	Check Engine	Amber	1686	Aftertreatment 1 Diesel Exhaust Fluid Tank 1 Quality	Aftertreatment Diesel Exhaust Fluid Quality Sensor Circuit - Voltage above normal, or shorted to high source
3364	4	Check Engine	Amber	1685	Aftertreatment 1 Diesel Exhaust Fluid Tank 1 Quality	Aftertreatment Diesel Exhaust Fluid Quality Sensor Circuit - Voltage below normal, or shorted to low source
3364	5	Check Engine	Amber	4741	Aftertreatment 1 Diesel Exhaust Fluid Tank 1 Quality	Aftertreatment Diesel Exhaust Fluid Quality Sensor Circuit - Current below normal or open circuit
3364	6	Check Engine	Amber	4742	Aftertreatment 1 Diesel Exhaust Fluid Tank 1 Quality	Aftertreatment Diesel Exhaust Fluid Quality Sensor Circuit - Current above normal or grounded circuit

REFERENCE

J1939 SPN	J1939 FMI	Telltale	Lamp	Cummins Fault Code	J1939_SPN Description	Detail
3364	7	Check Engine	Amber	3876	Aftertreatment 1 Diesel Exhaust Fluid Tank 1 Quality	Aftertreatment Diesel Exhaust Fluid Quality Sensor - Mechanical system not responding or out of adjustment
3364	9	Check Engine	Amber	3868	Aftertreatment 1 Diesel Exhaust Fluid Tank 1 Quality	Aftertreatment Diesel Exhaust Fluid Quality - Abnormal update rate
3364	10	Check Engine	Amber	4277	Aftertreatment 1 Diesel Exhaust Fluid Tank 1 Quality	Aftertreatment Diesel Exhaust Fluid Quality - Abnormal rate of change
3364	11	Check Engine	Amber	1715	Aftertreatment 1 Diesel Exhaust Fluid Tank 1 Quality	Aftertreatment Diesel Exhaust Fluid Quality - Root cause not known
3364	12	Check Engine	Amber	3877	Aftertreatment 1 Diesel Exhaust Fluid Tank 1 Quality	Aftertreatment Diesel Exhaust Fluid Quality Sensor - Bad intelligent device or component
3364	13	Check Engine	Amber	1714	Aftertreatment 1 Diesel Exhaust Fluid Tank 1 Quality	Aftertreatment Diesel Exhaust Fluid Quality - Out of Calibration
3364	15	Check Engine	None	4842	Aftertreatment Diesel Exhaust Fluid Quality	Aftertreatment Diesel Exhaust Fluid Quality - Data valid but above normal operating range - Least Severe Level
3364	18	Check Engine	None	6752	Aftertreatment 1 Diesel Exhaust Fluid Tank 1 Quality	Aftertreatment Diesel Exhaust Fluid Quality - Data valid but below normal operating range - Moderate Severe Level
3364	19	Check Engine	Amber	4241	Aftertreatment 1 Diesel Exhaust Fluid Tank 1 Quality	Aftertreatment Diesel Exhaust Fluid Quality - Received Network Data In Error
3464	3	Check Engine	None	6493	Electronic Throttle Control Actuator Driver Circuit	Electronic Throttle Control Actuator Driver Circuit - Voltage above normal, or shorted to high source
3464	4	Check Engine	None	6494	Electronic Throttle Control Actuator Driver Circuit	Electronic Throttle Control Actuator Driver Circuit - Voltage above normal, or shorted to low source
3464	5	Check Engine	None	6496	Electronic Throttle Control Actuator Driver Circuit	Electronic Throttle Control Actuator Driver Circuit - Voltage above normal, or shorted to high source
3509	3	Check Engine	Amber	386	Sensor supply voltage 1	Sensor Supply 1 Circuit - Voltage above normal, or shorted to high source

REFERENCE

J1939 SPN	J1939 FMI	Telltale	Lamp	Cummins Fault Code	J1939_SPN Description	Detail
3509	4	Check Engine	Amber	352	Sensor supply voltage 1	Sensor Supply 1 Circuit - Voltage below normal, or shorted to low source
3510	3	Check Engine	Amber	227	Sensor supply voltage 2	Sensor Supply 2 Circuit - Voltage above normal, or shorted to high source
3510	4	Check Engine	Amber	187	Sensor supply voltage 2	Sensor Supply 2 Circuit - Voltage below normal, or shorted to low source
3511	3	Check Engine	Amber	239	Sensor supply voltage 3	Sensor Supply 3 Circuit - Voltage above normal, or shorted to high source
3511	4	Check Engine	Amber	238	Sensor supply voltage 3	Sensor Supply 3 Circuit - Voltage below normal, or shorted to low source
3512	3	Check Engine	Amber	2185	Sensor supply voltage 4	Sensor Supply 4 Circuit - Voltage above normal, or shorted to high source
3512	4	Check Engine	Amber	2186	Sensor supply voltage 4	Sensor Supply 4 Circuit - Voltage below normal, or shorted to low source
3513	3	Check Engine	Amber	1695	Sensor supply voltage 5	Sensor Supply 5 Circuit- Voltage above normal, or shorted to high source
3513	4	Check Engine	Amber	1696	Sensor supply voltage 5	Sensor Supply 5 Circuit - Voltage below normal, or shorted to low source
3514	3	Check Engine	Amber	515	Sensor supply voltage 6	Sensor Supply 6 Circuit - Voltage above normal, or shorted to high source
3514	4	Check Engine	Amber	516	Sensor supply voltage 6	Sensor Supply 6 Circuit - Voltage below normal, or shorted to low source
3515	5	Check Engine	Amber	4743	Aftertreatment 1 Diesel Exhaust Fluid Temperature 2	Aftertreatment 1 Diesel Exhaust Fluid Temperature 2 Sensor Circuit - Current below normal or open circuit
3515	6	Check Engine	Amber	4744	Aftertreatment 1 Diesel Exhaust Fluid Temperature 2	Aftertreatment 1 Diesel Exhaust Fluid Temperature 2 Sensor Circuit - Current above normal or grounded
3515	10	Check Engine	None	6619	Aftertreatment 1 Diesel Exhaust Fluid Temperature 2	Aftertreatment 1 Diesel Exhaust Fluid Temperature 2 - Abnormal Rate of Change
3515	11	Check Engine	Amber	4745	Aftertreatment 1 Diesel Exhaust Fluid Temperature 2	Aftertreatment 1 Diesel Exhaust Fluid Temperature 2 - Root Cause Not Known

REFERENCE

J1939 SPN	J1939 FMI	Telltale	Lamp	Cummins Fault Code	J1939_SPN Description	Detail
3521	11	Check Engine	Amber	4768	Aftertreatment 1 Diesel Exhaust Fluid Property	Aftertreatment 1 Diesel Exhaust Fluid Property - Root Cause Not Known
3597	2	Check Engine	None	1117	ECU Power Output Supply Voltage #1	Power Supply Lost With Ignition On - Data is erratic, intermittent, or incorrect
3597	12	Check Engine	Amber	351	ECU Power Output Supply Voltage #1	Injector Power Supply - Bad intelligent device or component
3597	17	Check Engine	None	6499	ECU Power Output Supply Voltage #1	ECU Power Output Supply Voltage 1 - Data valid but below normal operating range - Moderately Severe Level
3597	18	Check Engine	Amber	1938	ECU Power Output Supply Voltage #1	ECU Power Output Supply Voltage 1 - Data valid but below normal operating range - Moderately Severe Level
3610	2	Check Engine	None	6553	Aftertreatment Diesel Particulate Filter Outlet Pressure	Aftertreatment 1 Diesel Particulate Filter Outlet Pressure - Data is erratic, intermittent, or incorrect
3610	3	Check Engine	None	6551	Aftertreatment Diesel Particulate Filter Outlet Pressure	Aftertreatment 1 Diesel Particulate Filter Outlet Pressure Sensor Circuit - Voltage above normal, or shorted to high source
3610	4	Check Engine	None	6552	Aftertreatment Diesel Particulate Filter Outlet Pressure	Aftertreatment 1 Diesel Particulate Filter Outlet Pressure Sensor Circuit - Voltage below normal, or shorted to low source
3667	2	Stop Engine	Red	5221	Engine Air Shutoff Status	Engine Air Shutoff Status - Data is erratic, intermittent, or incorrect
3667	3	Check Engine	Amber	3139	Engine Air Shutoff Status	Engine Air Shutoff Circuit - Voltage above normal, or shorted to high source
3667	4	Check Engine	Amber	3141	Engine Air Shutoff Status	Engine Air Shutoff Circuit - Voltage below normal, or shorted to low source
3667	7	Stop Engine	Red	4484	Engine Air Shutoff	Engine Air Shutoff - Mechanical System Not Responding or Out of Adjustment
3695	2	Check Engine	None	6568	Aftertreatment Regeneration Inhibit Switch	Aftertreatment Regeneration Inhibit Switch - Data is erratic, intermittent, or incorrect
3703	31	Check Engine	Amber (Blinking)	2777	Diesel Particulate Filter Active Regeneration Inhibited Due to Inhibit Switch	Particulate Trap Active Regeneration Inhibited Due to Inhibit Switch - Condition Exists

REFERENCE

J1939 SPN	J1939 FMI	Telltale	Lamp	Cummins Fault Code	J1939_SPN Description	Detail
3713	31	Check Engine	Amber	6596	Diesel Particulate Filter Active Regeneration Inhibited Due to	Diesel Particulate Filter Active Regeneration Inhibited Due to System Timeout - Condition exists
3750	14	Check Engine	Amber	5938	Diesel Particulate Filter 1 Conditions Not Met for Active Regeneration	Diesel Particulate Filter 1 Conditions Not Met for Active Regeneration – Condition exists
3936	7	Check Engine	None	6265	Aftertreatment 1 Diesel Particulate Filter System	Aftertreatment 1 Diesel Particulate Filter System - Mechanical system not responding or out of adjustment
3936	14	Stop Engine	Red	4584	Aftertreatment Diesel Particulate Filter System	Aftertreatment Diesel Particulate Filter System - Special Instructions
3936	15	Check Engine	Amber	1981	Aftertreatment Diesel Particulate Filter System	Aftertreatment 1 Diesel Particulate Filter System - Data valid but above normal operating range - Level
4094	31	Check Engine	Amber	3543	NOx limits exceeded due to Insufficient Diesel Exhaust Fluid Quality	NOx limits exceeded due to Insufficient Reagent Quality - Condition Exists
4096	31	Check Engine	Amber	3547	NOx limits exceeded due to Empty Diesel Exhaust Fluid Tank	Aftertreatment Diesel Exhaust Fluid Tank Empty - Condition Exists
4185	31	Check Engine	Amber	1427	Overspeed Shutdown Relay Driver	Overspeed Shutdown Relay Driver Diagnostic has detected an error - Condition Exists
4186	31	Check Engine	Amber	1428	Low Oil Pressure Shutdown Relay Driver	Low Oil Pressure (LOP) Shutdown Relay Driver Diagnostic has detected an error - Condition Exists
4187	31	Check Engine	Amber	1429	High Engine Temperature Shutdown Relay Driver	High Engine Temperature (HET) Shutdown Relay Driver Diagnostic has detected an error - Condition Exists
4188	31	Check Engine	Amber	1431	Pre-Low Oil Pressure Indicator Relay Driver	Pre-Low Oil Pressure Warning Relay Driver Diagnostic has detected an error - Condition exists
4223	31	Check Engine	Amber	1432	Pre-High Engine Temperature Warning Relay Driver	Pre-High Engine Temperature Warning Relay Driver Diagnostic has detected an error - Condition exists
4334	2	Check Engine	Amber	3596	Aftertreatment 1 Diesel Exhaust Fluid Doser Absolute Pressure	Aftertreatment 1 Diesel Exhaust Fluid Pressure Sensor - Data is erratic, intermittent, or incorrect

REFERENCE

J1939 SPN	J1939 FMI	Telltale	Lamp	Cummins Fault Code	J1939_SPN Description	Detail
4334	3	Check Engine	Amber	3571	Aftertreatment 1 Diesel Exhaust Fluid Doser Absolute Pressure	Aftertreatment 1 Diesel Exhaust Fluid Pressure Sensor - Voltage above normal, or shorted to high source
4334	4	Check Engine	Amber	3572	Aftertreatment 1 Diesel Exhaust Fluid Doser Absolute Pressure	Aftertreatment 1 Diesel Exhaust Fluid Pressure Sensor - Voltage below normal, or shorted to low source
4334	16	Check Engine	Amber	3575	Aftertreatment 1 Diesel Exhaust Fluid Doser Absolute Pressure	Aftertreatment 1 Diesel Exhaust Fluid Pressure Sensor - Data valid but above normal operating range
4334	18	Check Engine	Amber	3574	Aftertreatment 1 Diesel Exhaust Fluid Doser Absolute Pressure	Aftertreatment 1 Diesel Exhaust Fluid Pressure Sensor - Data Valid But Below Normal Operating Range
4337	10	Check Engine	Amber	4249	Aftertreatment 1 Diesel Exhaust Fluid Dosing Temperature	Aftertreatment 1 Diesel Exhaust Fluid Dosing Temperature - Abnormal Rate of Change
4340	3	Check Engine	None	6531	Aftertreatment 1 Diesel Exhaust Fluid Line Heater 1 State	Aftertreatment 1 Diesel Exhaust Fluid Line Heater 1 Circuit - Voltage above normal, or shorted to high source
4340	4	Check Engine	None	6532	Aftertreatment 1 Diesel Exhaust Fluid Line Heater 1 State	Aftertreatment 1 Diesel Exhaust Fluid Line Heater 1 Circuit - Voltage below normal, or shorted to low source
4340	5	Check Engine	None	6482	Aftertreatment 1 Diesel Exhaust Fluid Line Heater 1 State	Aftertreatment 1 Diesel Exhaust Fluid Line Heater 1 Circuit - Current below normal or open circuit
4342	3	Check Engine	None	6533	Aftertreatment 1 Diesel Exhaust Fluid Line Heater 2 State	Aftertreatment 1 Diesel Exhaust Fluid Line Heater 2 Circuit - Voltage above normal, or shorted to high source
4342	4	Check Engine	None	6534	Aftertreatment 1 Diesel Exhaust Fluid Line Heater 2 State	Aftertreatment 1 Diesel Exhaust Fluid Line Heater 2 Circuit - Voltage below normal, or shorted to low source
4342	5	Check Engine	None	6483	Aftertreatment 1 Diesel Exhaust Fluid Line Heater 2 State	Aftertreatment 1 Diesel Exhaust Fluid Line Heater 2 Circuit - Current below normal or open circuit
4344	3	Check Engine	None	6535	Aftertreatment 1 Diesel Exhaust Fluid Line Heater 3 State	Aftertreatment Diesel Exhaust Fluid Line Heater 3 Circuit - Voltage above normal, or shorted to high source

REFERENCE

J1939 SPN	J1939 FMI	Telltale	Lamp	Cummins Fault Code	J1939_SPN Description	Detail
4344	4	Check Engine	None	6536	Aftertreatment 1 Diesel Exhaust Fluid Line Heater 3 State	Aftertreatment Diesel Exhaust Fluid Line Heater 3 Circuit - Voltage below normal, or shorted to low source
4344	5	Check Engine	None	6484	Aftertreatment 1 Diesel Exhaust Fluid Line Heater 3 State	Aftertreatment Diesel Exhaust Fluid Line Heater 3 Circuit - Current below normal or open circuit
4360	0	Stop Engine	Red	3229	Aftertreatment 1 SCR Catalyst Intake Gas Temperature	Aftertreatment 1 SCR Intake Temperature - Data valid but above normal operational range - Most Severe Level
4360	2	Check Engine	Amber	3144	Aftertreatment 1 SCR Catalyst Intake Gas Temperature	Aftertreatment 1 SCR Intake Temperature Sensor - Data is erratic, intermittent, or incorrect
4360	3	Check Engine	Amber	3142	Aftertreatment 1 SCR Catalyst Intake Gas Temperature	Aftertreatment 1 SCR Intake Temperature Sensor Circuit - Voltage above normal, or shorted to high source
4360	4	Check Engine	Amber	3143	Aftertreatment 1 SCR Catalyst Intake Gas Temperature	Aftertreatment 1 SCR Intake Temperature Sensor Circuit - Voltage below normal, or shorted to low source
4360	15	Check Engine	None	3164	Aftertreatment 1 SCR Catalyst Intake Gas Temperature	Aftertreatment 1 SCR Intake Temperature - Data valid but above normal operating range - Least Severe
4360	16	Stop Engine	Red	3231	Aftertreatment 1 SCR Catalyst Intake Gas Temperature	Aftertreatment 1 SCR Intake Temperature - Data valid but above normal operating range - Moderately Severe Level
4363	0	Stop Engine	Red	3165	Aftertreatment 1 SCR Catalyst Outlet Gas Temperature	Aftertreatment 1 SCR Outlet Temperature - Data valid but above normal operational range - Most Severe
4363	2	Check Engine	Amber	3148	Aftertreatment 1 SCR Catalyst Outlet Gas Temperature	Aftertreatment 1 SCR Outlet Temperature Sensor - Data is erratic, intermittent, or incorrect
4363	3	Check Engine	None	6569	Aftertreatment 1 SCR Catalyst Outlet Gas Temperature	Aftertreatment 1 SCR Outlet Temperature Sensor Circuit - Voltage above normal, or shorted to high source
4363	4	Check Engine	None	6571	Aftertreatment 1 SCR Catalyst Outlet Gas Temperature	Aftertreatment 1 SCR Outlet Temperature Sensor Circuit - Voltage below normal, or shorted to low source

REFERENCE

J1939 SPN	J1939 FMI	Telltale	Lamp	Cummins Fault Code	J1939_SPN Description	Detail
4363	16	Stop Engine	Red	3235	Aftertreatment 1 SCR Catalyst Outlet Gas Temperature	Aftertreatment 1 SCR Outlet Temperature - Data valid but above normal operating range - Moderately Severe Level
4364	17	Check Engine	None	6517	Aftertreatment 1 SCR Conversion Efficiency	Aftertreatment SCR Catalyst Conversion Efficiency - Data valid but below normal operating range - Moderately Severe Level
4364	18	Check Engine	Amber	3582	Aftertreatment 1 SCR Conversion Efficiency	Aftertreatment SCR Catalyst Conversion Efficiency - Data valid but below normal operating range - Moderately Severe Level
4376	3	Check Engine	Amber	3577	Aftertreatment 1 Diesel Exhaust Fluid Return Valve	Aftertreatment Diesel Exhaust Fluid Return Valve - Voltage above normal, or shorted to high source
4376	4	Check Engine	Amber	3578	Aftertreatment 1 Diesel Exhaust Fluid Return Valve	Aftertreatment Diesel Exhaust Fluid Return Valve - Voltage below normal, or shorted to low source
4376	7	Check Engine	None	6527	Aftertreatment 1 Diesel Exhaust Fluid Return Valve	Aftertreatment Diesel Exhaust Fluid Return Valve - Mechanical system not responding or out of adjust
4765	2	Check Engine	None	6539	Aftertreatment Diesel Oxidation Catalyst Intake Temperature	Aftertreatment 1 Diesel Oxidation Catalyst Intake Temperature - Data is erratic, intermittent, or incorrect
4765	3	Check Engine	Amber	3314	Aftertreatment Diesel Oxidation Catalyst Intake Temperature	Aftertreatment 1 Diesel Oxidation Catalyst Intake Temperature Sensor Circuit - Voltage above normal, or shorted to high source
4765	4	Check Engine	Amber	3313	Aftertreatment Diesel Oxidation Catalyst Intake Temperature	Aftertreatment 1 Diesel Oxidation Catalyst Intake Temperature Sensor Circuit - Voltage below normal, or shorted to low source
4765	16	Stop Engine	Red	3251	Aftertreatment Diesel Oxidation Catalyst Intake Temperature	Aftertreatment 1 Diesel Oxidation Catalyst Intake Temperature - Data valid but above normal operating range
4766	0	Stop Engine	Red	5387	Aftertreatment 1 Diesel Oxidation Catalyst Outlet Gas Temperature	Aftertreatment 1 Diesel Oxidation Catalyst Outlet Gas Temperature - Data valid but above normal operating range - Most Severe Level
4766	2	Check Engine	Amber	5386	Aftertreatment 1 Diesel Oxidation Catalyst Outlet Gas Temperature	Aftertreatment 1 Diesel Oxidation Catalyst Outlet Gas Temperature - Data is erratic, intermittent, or Incorrect

REFERENCE

J1939 SPN	J1939 FMI	Telltale	Lamp	Cummins Fault Code	J1939_SPN Description	Detail
4766	3	Check Engine	Amber	4533	Aftertreatment 1 Diesel Oxidation Catalyst Outlet Gas Temperature Sensor Circuit	Aftertreatment 1 Diesel Oxidation Catalyst Outlet Gas Temperature Sensor Circuit - Voltage above normal, or shorted to high source
4766	4	Check Engine	Amber	4534	Aftertreatment 1 Diesel Oxidation Catalyst Outlet Gas Temperature Sensor Circuit	Aftertreatment 1 Diesel Oxidation Catalyst Outlet Gas Temperature Sensor Circuit - Voltage below normal, or shorted to low source
4766	15	Check Engine	Amber	5389	Aftertreatment 1 Diesel Oxidation Catalyst Outlet Gas Temperature	Aftertreatment 1 Diesel Oxidation Catalyst Outlet Gas Temperature - Data valid but above normal operating range - Least Severe Level
4766	16	Stop Engine	Red	5388	Aftertreatment 1 Diesel Oxidation Catalyst Outlet Gas Temperature	Aftertreatment 1 Diesel Oxidation Catalyst Outlet Gas Temperature - Data valid but above normal operating range - Moderately Severe Level
4792	7	Check Engine	None	3751	Aftertreatment SCR Catalyst System	Aftertreatment SCR Catalyst System - Mechanical system not responding or out of adjustment
4792	14	Stop Engine	Red	4585	Aftertreatment 1 SCR Catalyst System	Aftertreatment 1 SCR Catalyst System - Special Instructions
4794	31	Check Engine	Amber	3151	Aftertreatment 1 SCR Catalyst System	Aftertreatment 1 SCR Catalyst System Missing - Condition exists
4795	31	Check Engine	Amber	1993	Aftertreatment 1 Diesel Particulate Filter Missing	Aftertreatment 1 Diesel Particulate Filter Missing - Condition exists
4796	31	Check Engine	None	6621	Aftertreatment 1 Diesel Oxidation Catalyst Missing	Aftertreatment 1 Diesel Oxidation Catalyst Missing - Condition exists
5018	11	Check Engine	None	2637	Aftertreatment Diesel Oxidation Catalyst	Aftertreatment 1 Diesel Oxidation Catalyst Face Plugged - Root cause not known
5024	10	Check Engine	Amber	3649	Aftertreatment 1 Intake Gas NOx Sensor Heater Ratio	Aftertreatment 1 Intake NOx Sensor Heater - Abnormal rate of change
5031	10	Check Engine	None	6581	Aftertreatment 1 Outlet Gas NOx Sensor Heater Ratio	Aftertreatment 1 Outlet NOx Sensor Heater - Abnormal rate of change
5125	3	Check Engine	Amber	3419	Sensor supply voltage 7	Sensor Supply 7 Circuit - Voltage above normal, or shorted to high source
5125	4	Check Engine	Amber	3421	Sensor supply voltage 7	Sensor Supply 7 Circuit - Voltage below normal, or shorted to low source

REFERENCE

J1939 SPN	J1939 FMI	Telltale	Lamp	Cummins Fault Code	J1939_SPN Description	Detail
5245	31	Check Engine	Amber	4863	Aftertreatment Selective Catalytic Reduction Operator Inducement Active	Aftertreatment Diesel Exhaust Fluid Tank Low Level Indicator
5246	0	Stop Engine	Red	3712	Aftertreatment SCR Operator Inducement Severity	Aftertreatment SCR Operator Inducement - Data valid but above normal operational range - Most Severe Level
5298	17	Check Engine	None	2638	Aftertreatment 1 Diesel Oxidation Catalyst Conversion Efficiency	Aftertreatment 1 Diesel Oxidation Catalyst Conversion Efficiency - Data valid but below normal operating range - Moderately Severe Level
5298	18	Check Engine	Amber	1691	Aftertreatment 1 Diesel Oxidation Catalyst Conversion Efficiency	Aftertreatment 1 Diesel Oxidation Catalyst Conversion Efficiency - Data valid but below normal operating range - Moderately Severe Level
5319	31	Check Engine	Amber	3376	Aftertreatment 1 Diesel Particulate Filter Incomplete Regeneration	Aftertreatment Diesel Particulate Filter Incomplete Regeneration - Condition Exists
5394	2	Check Engine	None	3755	Aftertreatment Diesel Exhaust Fluid Dosing Valve	Aftertreatment Diesel Exhaust Fluid Dosing Valve - Data is erratic, intermittent, or incorrect
5394	5	Check Engine	Amber	3567	Aftertreatment Diesel Exhaust Fluid Dosing Valve	Aftertreatment Diesel Exhaust Fluid Dosing Valve - Current below normal or open circuit
5394	7	Check Engine	Amber	3568	Aftertreatment Diesel Exhaust Fluid Dosing Valve	Aftertreatment Diesel Exhaust Fluid Dosing Valve - Mechanical system not responding or out of adjustment
5397	31	Check Engine	Amber	3375	Aftertreatment 1 Diesel Particulate Filter Regeneration too Frequent	Aftertreatment Diesel Particulate Filter Regeneration too Frequent - Condition Exists
5484	3	Check Engine	None	6456	Engine Fan Clutch 2 Output Device Driver	Engine Fan Clutch 2 Control Circuit - Voltage above normal, or shorted to high source
5484	4	Check Engine	None	6457	Engine Fan Clutch 2 Output Device Driver	Engine Fan Clutch 2 Control Circuit - Voltage below normal, or shorted to low source
5491	3	Check Engine	None	6477	Aftertreatment 1 Diesel Exhaust Fluid Line Heater Relay	Aftertreatment Diesel Exhaust Fluid Line Heater Relay - Voltage above normal, or shorted to high source

REFERENCE

J1939 SPN	J1939 FMI	Telltale	Lamp	Cummins Fault Code	J1939_SPN Description	Detail
5491	4	Check Engine	None	6478	Aftertreatment 1 Diesel Exhaust Fluid Line Heater Relay	Aftertreatment Diesel Exhaust Fluid Line Heater Relay - Voltage below normal, or shorted to low source
5491	7	Check Engine	None	6537	Aftertreatment 1 Diesel Exhaust Fluid Line Heater Relay	Aftertreatment 1 Diesel Exhaust Fluid Line Heater Relay - Mechanical system not responding or out of adjustment
5571	0	Check Engine	Amber	3741	High-Pressure Common Rail Fuel Pressure Relief Valve	High-Pressure Common Rail Fuel Pressure Relief Valve - Data valid but above normal operational range
5571	3	Check Engine	Amber	4262	High-Pressure Common Rail Fuel Pressure Relief Valve	High-Pressure Common Rail Fuel Pressure Relief Valve - Voltage Above Normal, or Shorted to High Source
5571	4	Check Engine	Amber	4263	High-Pressure Common Rail Fuel Pressure Relief Valve	High-Pressure Common Rail Fuel Pressure Relief Valve - Voltage below normal, or shorted to low source
5571	7	Check Engine	None	3727	High-Pressure Common Rail Fuel Pressure Relief Valve	High-Pressure Common Rail Fuel Pressure Relief Valve - Mechanical system not responding or out of adjustment
5571	15	Check Engine	Amber	5585	High-Pressure Common Rail Fuel Pressure Relief Valve	High-Pressure Common Rail Fuel Pressure Relief Valve - Data valid but above normal operating range - Least Severe Level
5571	31	Check Engine	Amber	4867	High-Pressure Common Rail Fuel Pressure Relief Valve	High-Pressure Common Rail Fuel Pressure Relief Valve - Condition Exists
5603	9	Check Engine	None	3843	Cruise Control Disable Command	Cruise Control Disable Command - Abnormal update rate
5603	31	Check Engine	None	3845	Cruise Control Disable Command	Cruise Control Disable Command - Condition Exists
5605	31	Check Engine	None	3844	Cruise Control Pause Command	Cruise Control Pause Command - Condition Exists
5742	3	Check Engine	Amber	4161	Aftertreatment Diesel Particulate Filter Temperature Sensor Module	Aftertreatment Diesel Particulate Filter Temperature Sensor Module - Voltage Above Normal, or Shorted to high source
5742	4	Check Engine	Amber	4162	Aftertreatment Diesel Particulate Filter Temperature Sensor Module	Aftertreatment Diesel Particulate Filter Temperature Sensor Module - Voltage below normal, or shorted to low source

REFERENCE

J1939 SPN	J1939 FMI	Telltale	Lamp	Cummins Fault Code	J1939_SPN Description	Detail
5742	9	Check Engine	Amber	4151	Aftertreatment Diesel Particulate Filter Temperature Sensor Module	Aftertreatment Diesel Particulate Filter Temperature Sensor Module - Abnormal update rate
5742	11	Check Engine	Amber	4259	Aftertreatment Diesel Particulate Filter Temperature Sensor Module	Aftertreatment Diesel Particulate Filter Temperature Sensor Module - Root Cause Not Known
5742	12	Check Engine	Amber	4158	Aftertreatment Diesel Particulate Filter Temperature Sensor Module	Aftertreatment Diesel Particulate Filter Temperature Sensor Module - Bad intelligent device or component
5742	16	Check Engine	Amber	4163	Aftertreatment Diesel Particulate Filter Temperature Sensor Module	Aftertreatment Diesel Particulate Filter Temperature Sensor Module - Data valid but above normal operating range
5743	3	Check Engine	Amber	4164	Aftertreatment Selective Catalytic Reduction Temperature Sensor Module	Aftertreatment Selective Catalytic Reduction Temperature Sensor Module - Voltage Above Normal, or Shorted to high source
5743	4	Check Engine	Amber	4165	Aftertreatment Selective Catalytic Reduction Temperature Sensor Module	Aftertreatment Selective Catalytic Reduction Temperature Sensor Module - Voltage below normal, or Shorted to low source
5743	9	Check Engine	Amber	4152	Aftertreatment Selective Catalytic Reduction Temperature Sensor Module	Aftertreatment Selective Catalytic Reduction Temperature Sensor Module - Abnormal update rate
5743	11	Check Engine	Amber	4261	Aftertreatment Selective Catalytic Reduction Temperature Sensor Module	Aftertreatment Selective Catalytic Reduction Temperature Sensor Module - Root Cause Not Known
5743	12	Check Engine	Amber	4159	Aftertreatment Selective Catalytic Reduction Temperature Sensor Module	Aftertreatment Selective Catalytic Reduction Temperature Sensor Module - Bad intelligent device or component
5743	16	Check Engine	Amber	4166	Aftertreatment Selective Catalytic Reduction Temperature Sensor Module	Aftertreatment Selective Catalytic Reduction Temperature Sensor Module - Data valid, but above normal
5745	3	Check Engine	Amber	4168	Aftertreatment 1 Diesel Exhaust Fluid Supply Module Heater	Aftertreatment 1 Diesel Exhaust Fluid Supply Module Heater - Voltage above normal, or shorted to high
5745	4	Check Engine	Amber	4169	Aftertreatment 1 Diesel Exhaust Fluid Supply Module Heater	Aftertreatment 1 Diesel Exhaust Fluid Supply Module Heater - Voltage below normal, or shorted to low source

REFERENCE

J1939 SPN	J1939 FMI	Telltale	Lamp	Cummins Fault Code	J1939_SPN Description	Detail
5745	17	Check Engine	None	6513	Aftertreatment 1 Diesel Exhaust Fluid Supply Module Heater	Aftertreatment 1 Diesel Exhaust Fluid Supply Module Heater - Data valid, but below normal operating range
5745	18	Check Engine	Amber	4171	Aftertreatment 1 Diesel Exhaust Fluid Supply Module Heater	Aftertreatment 1 Diesel Exhaust Fluid Supply Module Heater - Data valid, but below normal operating range
5746	3	Check Engine	None	6529	Aftertreatment 1 Diesel Exhaust Fluid Supply Module Heater Relay	Aftertreatment 1 Diesel Exhaust Fluid Supply Module Heater Relay - Voltage above normal, or shorted to high source
5746	4	Check Engine	Amber	4156	Aftertreatment 1 Diesel Exhaust Fluid Supply Module Heater Relay	Aftertreatment 1 Diesel Exhaust Fluid Supply Module Heater Relay - Voltage below normal, or shorted to low source
5798	10	Check Engine	Amber	4251	Aftertreatment 1 Diesel Exhaust Fluid Supply Module Heater Temperature	Aftertreatment 1 Diesel Exhaust Fluid Supply Module Heater Temperature - Abnormal Rate of Change
6655	3	Check Engine	None	6511	ECU Power Lamp	Maintain ECU Power Lamp - Voltage above normal, or shorted to high source
6655	4	Check Engine	None	6512	ECU Power Lamp	Maintain ECU Power Lamp - Voltage below normal, or shorted to low source
6713	9	Check Engine	Amber	5177	VGT Actuator Driver Circuit	VGT Actuator Driver Circuit - Abnormal update rate
6713	13	Stop Engine	Red	4956	Variable Geometry Turbocharger Actuator	Variable Geometry Turbocharger Actuator Software - Out of Calibration
6713	31	Stop Engine	Red	4957	Variable Geometry Turbocharger Actuator	Variable Geometry Turbocharger Actuator Software - Condition exists
6799	2	Check Engine	None	6473	Engine Fan Blade Pitch	Fan Blade Pitch - Mechanical system not responding or out of adjustment
6799	3	Check Engine	None	6471	Engine Fan Blade Pitch	Fan Blade Pitch Position Sensor Circuit - Voltage above normal, or shorted to high source
6799	4	Check Engine	None	6472	Engine Fan Blade Pitch	Fan Blade Pitch Position Sensor Circuit - Voltage below normal, or shorted to low source
6799	7	Check Engine	Amber	5185	Engine Fan Blade Pitch	Fan Blade Pitch - Mechanical system not responding or out of adjustment

REFERENCE

J1939 SPN	J1939 FMI	Telltale	Lamp	Cummins Fault Code	J1939_SPN Description	Detail
6802	31	Check Engine	Amber	5278		Aftertreatment 1 Diesel Exhaust Fluid Dosing System Frozen - Condition Exists
6881	9	Check Engine	Amber	5653	SCR Operator Inducement Override Switch	SCR Operator Inducement Override Switch - Abnormal Update Rate
6881	13	Check Engine	Amber	5654	SCR Operator Inducement Override Switch	SCR Operator Inducement Override Switch - Out of Calibration
6882	3	Check Engine	Amber	5393	Aftertreatment Diesel Oxidation Catalyst Temperature Sensor Module	Aftertreatment Diesel Oxidation Catalyst Temperature Sensor Module - Voltage above normal or shorted to high source
6882	4	Check Engine	Amber	5394	Aftertreatment Diesel Oxidation Catalyst Temperature Sensor Module	Aftertreatment Diesel Oxidation Catalyst Temperature Sensor Module - Voltage below normal or shorted to low source
6882	9	Check Engine	Amber	5391	Aftertreatment Diesel Oxidation Catalyst Temperature Sensor Module	Aftertreatment Diesel Oxidation Catalyst Temperature Sensor Module - Abnormal update rate
6882	11	Check Engine	Amber	5395	Aftertreatment Diesel Oxidation Catalyst Temperature Sensor Module	Aftertreatment Diesel Oxidation Catalyst Temperature Sensor Module - Root cause not known
6882	12	Check Engine	Amber	5392	Aftertreatment Diesel Oxidation Catalyst Temperature Sensor Module	Aftertreatment Diesel Oxidation Catalyst Temperature Sensor Module - Bad Intelligent Device or Component
6882	16	Check Engine	Amber	5396	Aftertreatment Diesel Oxidation Catalyst Temperature Sensor Module	Aftertreatment Diesel Oxidation Catalyst Temperature Sensor Module - Data valid but above normal operating range - Moderately Severe Level
6918	31	Check Engine	Maintenance	5632	SCR System Cleaning Inhibited Due to Inhibit Switch	SCR System Cleaning Inhibited Due to Inhibit Switch - Condition exists
6928	31	Check Engine	Amber	6597	SCR System Cleaning Inhibited Due to System Timeout	SCR System Cleaning Inhibited Due to System Timeout - Condition exists
7848	31	Check Engine	Amber	6634	Diesel Particulate Filter 1 Conditions Not Met for Active Regeneration	Diesel Particulate Filter 1 Conditions Not Met for Active Regeneration - Condition exists
520808	31	Check Engine	Amber	5291	Engine Emergency Shutdown Switch Activated	Engine Emergency Shutdown Switch Activated - Condition exists

REFERENCE

J1939 SPN	J1939 FMI	Telltale	Lamp	Cummins Fault Code	J1939_SPN Description	Detail
520809	31	Check Engine	Amber	5292	Excessive Time Since Last Engine Air Shutoff Maintenance Test	Excessive Time Since Last Engine Air Shutoff Maintenance Test - Condition exists
520968	9	Check Engine	Amber	5939		Machine Constrained Operation - Abnormal Update Rate. No Communication or an invalid data transfer rate has been detected on the J1939 data link between the ECM and the machine electronic unit.
520968	19	Check Engine	None	5941		Machine Constrained Operation - Received Network Data in Error. The received J1939 datalink message was not valid.
524286	31	Check Engine	Amber	5617	Aftertreatment 1 Diesel Oxidation Catalyst System	Aftertreatment 1 Diesel Oxidation Catalyst System - Special Instruction

Index

A

A Series headers	
definition.....	27
A40DX Auger Headers	
auger run screens.....	276
run screen 1.....	276
run screen 2.....	277
auger speed	
adjusting.....	262
connecting hydraulics.....	157
detaching from windrower.....	159
disc speed switch.....	73
float options with fixed deck.....	274
knife speed.....	269
adjusting knife alarm pressure.....	271
adjusting knife speed alarm.....	272
setting knife speed while moving.....	269
mechanically connecting to M1 Series.....	151
operating.....	262
reel speed	
adjusting.....	262
adjusting reel alarm pressure.....	267
setting reel speed in auto mode.....	262
setting reel speed in manual mode.....	264
aftertreatment functions	
activating.....	127
air conditioning	
cleaning evaporator core.....	398
compressor	
replacing belts.....	405
tensioning belts.....	326, 404
filters	
fresh air intake filter.....	344
inspecting and cleaning.....	345
installing filter.....	346
removing filter.....	344
installing cover.....	399
removing cover.....	397
testing/troubleshooting	
cab air.....	455
air conditioning box connectors	
welding precautions.....	9
air filters, <i>See</i> filters	
alarm volume.....	91
annual service.....	113
anti-shimmy dampeners	
location.....	34
antifreeze.....	400
API	
definition.....	27
armrest.....	40
ASTM	

definition.....	27
attaching/detaching headers	
A40DX Auger Headers	
attaching to windrower.....	151
connecting hydraulics.....	157
detaching from windrower.....	159
D1X or D1XL Series Draper Headers	
attaching draper header supports.....	162
connecting center-link.....	163
connecting hydraulics.....	169
detaching from windrower.....	171
hydraulic center-link with optional self-alignment kit.....	163
hydraulic center-link without optional self-alignment kit.....	163
hydraulic center-link without self-alignment kit.....	163
R113 or R216 Rotary Disc Headers	
attaching to windrower.....	175
connecting hydraulics.....	181
R113 Rotary Disc Headers	
detaching from windrower.....	191
R216 Rotary Disc Headers	
detaching from windrower.....	196
R85 4.9 m (16 ft.) Rotary Disc Header	
connecting hydraulics.....	206
R85 4.9 m (16 ft.) Rotary Disc Headers	
attaching to windrower.....	200
detaching from windrower.....	208
auger alarm pressure	
adjusting.....	267
auger pressure	
viewing.....	276
auger speed	
adjusting.....	262
viewing.....	276–277
automated steering systems.....	439
autosteer engagement button.....	69, 71
autosteer, <i>See</i> automated steering systems	

B

ballast kits.....	443
batteries	
auxiliary power posts.....	395
battery cable.....	390
battery cover	
closing.....	387
opening.....	387
battery safety.....	8
battery specification.....	386
boosting.....	390

INDEX

charging 388
connecting 393
disconnecting 393
installing 392
maintaining 386
removing 391
troubleshooting 449
welding precautions 9
beacon lights 55
 location 34
 switch 51
belts 403
 A/C compressor belt
 replacing 405
 engine fan drive belt
 replacing 403
 tensioning 403
 seat belts 48
 tensioning A/C compressor belt 326, 404
Bluetooth® feature 64
bolts
 definition 27
booster spring kit 440
break-in inspections
 schedule 298
break-in period 112

C

cab
 entering 129
 exiting 129
 specifications 30
 troubleshooting cab air 455
cab connectors
 welding precautions 9
cab temperature, *See* HVAC systems
cab-forward
 definition 27
calibration
 header 213
 windrower 213
caster wheels, *See* wheels and tires
center-links
 definition 27
 location 34
 self-locking center-link hook mechanism 228
CGVW
 definition 27
charge filters
 installing 333
chassis extension module
 welding precautions 9
chassis relay module
 welding precautions 9

circuit breakers
 accessing circuit breakers 420
 replacing 422
climate controls 59–60, 77
 See also HVAC systems
component locations 34
compressors
 replacing compressor belts 405
 tensioning belts 326, 404
consoles 37
conversion chart 467
conversion kit for disc ready to disc, auger, and draper
 ready 440
conveyor speed adjustment buttons 76
coolant
 adding to engine 381
 checking level in engine 341
coolant temperature gauges 77
cooling system
 twin-flow cooling system 309

D

D1X Series
 definition 27
D1X Series Draper Headers
 adjusting reel alarm pressure 241
 attaching to windrower
 connecting hydraulics 169
 draper header supports 162
 deck shift 254
 deck shift control 254
 float options with deck shift 255
 setting float options 255
detaching from windrower
 units with hydraulic center-link 171
draper run screens 256
 run screen 1 257
 run screen 2 258
draper speed
 adjusting 243
 adjusting draper alarm pressure 246
 draper slip warning 248
 setting draper speed in auto mode 243
 setting draper speed in manual mode 245
header float
 float options with deck shift 255
header position
 leveling the header 236
hydraulic center-link with optional self-alignment kit
 attaching to M1240 Windrower 163
hydraulic center-link without self-alignment kit
 attaching to M1240 Windrower 163
knife speed 249
 knife speed alarm

INDEX

- adjusting alarm 252
- adjusting pressure 251
- setting knife speed 250
- operating 234
- reel speed
 - adjusting reel speed 238
 - setting reel speed in auto mode 238
 - setting reel speed in manual mode 240
- D1XL Series
 - definition 27
- D1XL Series Draper Headers
 - adjusting reel alarm pressure 241
 - attaching to windrower
 - connecting hydraulics 169
 - draper header supports 162
 - deck shift 254
 - deck shift control 254
 - float options with deck shift 255
 - setting float options 255
 - detaching from windrower
 - units with hydraulic center-link 171
 - draper run screens 256
 - run screen 1 257
 - run screen 2 258
 - draper speed
 - adjusting 243
 - adjusting draper alarm pressure 246
 - draper slip warning 248
 - setting draper speed in auto mode 243
 - setting draper speed in manual mode 245
 - header float
 - float options with deck shift 255
 - header position 234
 - leveling the header 236
 - reel fore-aft position 234
 - reel height 235
 - hydraulic center-link with optional self-alignment kit
 - attaching to M1240 Windrower 163
 - hydraulic center-link without self-alignment kit
 - attaching to M1240 Windrower 163
 - knife speed 249
 - knife speed alarm
 - adjusting alarm 252
 - adjusting pressure 251
 - setting knife speed 250
 - operating 234
 - reel speed
 - adjusting reel speed 238
 - setting reel speed in auto mode 238
 - setting reel speed in manual mode 240
- date
 - setting on HPT 92
- decals
 - fuse box and relay module decals 423
 - location of safety signs 16
- deck shift 75, 254
 - controls 75
- deck shift control 254
- DEF, *See* diesel exhaust fluid system
- DEF gauges 77
- definition of terms 27
- diesel exhaust fluid system 307
 - DEF tank
 - draining the tank 307, 402
 - filling the tank 116, 308
 - exhaust system cleaning 126
 - filters
 - changing vent hose filter 385
 - supply module filter 377
 - checking filter 377
 - cleaning and inspecting filter 379
 - installing filter 379
 - removing filter 377
- differential auger-reel control 262
- disc pressure
 - viewing 283–284, 290–291
- disc pressure alarm
 - adjusting 279, 286
- disc speed
 - setting for R85 Rotary Disc Header 278
 - viewing 283–284, 290–291
- disc speed switch 73
- DK
 - definition 27
- DM
 - definition 27
- DOC
 - definition 27
- doors
 - location 34
- double booster spring kit — external 441
- double windrow attachment shut-off kit 441
- double windrow attachments 75, 229
 - conveyor speed adjustment buttons 76
 - deck position 230
 - draper speed 230
 - raising deck 76
- double windrowing 229
- draper headers
 - operating a D1X or D1XL Series Draper Header 234
- draper pressure
 - viewing 257
- draper speed 75
 - D1X and D1XL Series Draper Headers
 - setting in manual mode 245
 - setting in auto mode 243
 - viewing 257–258
- draper speed controls 76
- drive wheels, *See* wheels and tires
- driving the windrower

INDEX

- adjusting ground speed limit 130
 - driving on road 139, 142
 - engine-forward operation 134
 - entering/exiting the windrower 129
 - forward in cab-forward mode 131
 - reverse in cab-forward mode 133
 - reverse in engine-forward mode 136
 - spin turn 137
 - stopping 137
 - DWA, *See* double window attachments

 - E**
 - EC declaration of conformity i
 - ECM
 - definition 27
 - eco engine control (EEC)
 - programming the EEC 124
 - using the EEC 68
 - ECU
 - definition 27
 - electrical systems 317
 - auxiliary power posts 395
 - battery
 - battery cover
 - closing 387
 - opening 387
 - boosting 390
 - charging 388
 - connecting 393
 - disconnecting 393
 - installing 392
 - maintaining 386
 - removing 391
 - extension modules 321
 - fuses and relays 423
 - checking and replacing fuses 421
 - inspecting/replacing 125A main fuses 428
 - relay modules 321
 - replacing circuit breakers/relays 422
 - master controller 321
 - module layout 317
 - preventing damage to electrical systems 322
 - specifications 30
 - troubleshooting 449
- engaging the header 225
- engine air intake temperatures 128
- engine control module
 - welding precautions 9
- engine coolant temperatures 128
- engine cooling system
 - air conditioning (A/C) 313
 - charge air cooler (CAC) 311
 - cooling module
 - cleaning screens and components 350, 353
 - engine coolant
 - adding coolant 381
 - checking coolant level 341
 - checking coolant strength 400
 - draining coolant 380
 - hydraulic oil cooler 312
 - pressurized coolant tank cap
 - inspecting pressurized coolant tank cap 310
- engine harness
 - welding precautions 9
- engine interlock 374
- engine load
 - viewing 277, 283–284, 290–291
- engine operation
 - engine aftertreatment switches
 - manual SCR conditioning/inhibit switches 127
 - engine speed 405
 - engine temperature 125
 - exhaust aftertreatment system
 - exhaust system cleaning 126
 - fueling 115
 - oil pressure 126
 - shutting down the engine 125
- engine rpm 77
- engine-forward
 - definition 27
- engines
 - adding coolant 381
 - adding oil 118, 335, 357
 - air intake system 314
 - belts 403
 - charge air cooling 312
 - checking coolant level 341
 - checking cooling data 128
 - checking interlock 374
 - checking oil level 117, 334
 - cooling system
 - twin-flow cooling system 309
- eco engine control (EEC)
 - programming the EEC 124
 - using the EEC 68
- electronics 14
- engine air filter
 - changing secondary air filter 361
 - cleaning primary air filter 361
 - installing primary air filter 360
 - maintaining filters 358
 - removing primary air filter 358
- engine compartment 302
- engine controls 67
- engine exhaust system
 - inspecting exhaust system 365
- engine gearbox maintenance
 - adding lubricant 343
 - changing lubricant 327, 367

INDEX

checking lubricant level.....	343	changing secondary air filter	361
engine oil change	356	cleaning primary filter element	361
draining oil	356	installing primary air filter	360
engine oil filter	357	removing primary air filter.....	358
engine operation		engine oil filter	
eco engine control programming.....	124	replacing engine oil filter.....	357
starting the engine	119	fresh air intake filter	344
troubleshooting	123	fuel filters	
fault codes	514	maintaining fuel filters.....	369
faults and telltales.....	88	primary fuel filter	
general engine inspection.....	385	installing	370
manuals	385	removing	369
power	14	removing/installing fuel tank vent filter	375
removing water from fuel system.....	336	secondary fuel filter	
safety.....	13	installing	371
specifications	30	removing	370
speed.....	14	HVAC filters	
troubleshooting	445	fresh air intake filter	
engine start	123	inspecting and cleaning	345
entering the cab.....	129	installing filter.....	346
evaporator	397	removing filter	344
evaporator core		return oil filter	
cleaning.....	398	installing	331
exhaust aftertreatment system		removing.....	330
activating.....	127	final drives	149
exhaust system		finger tight	
cleaning.....	126	definition.....	27
inspecting	365	firewall extension module	
exiting the cab	129	welding precautions	9
external booster spring kit	440	float, <i>See</i> header float	
F		float booster springs	
fan speeds.....	128	spring with external booster spring kit	440
fault codes		float preset	75
engine fault codes.....	514	float springs	
windrower fault codes	468	location	34
FFFT		fluids, fuel, and lubricants.....	293
definition.....	27	fuel gauges.....	77
field lights		fuel systems	
location	34	fluids, fuel, and lubricants.....	293
switch	51	fuel filters	
symbol	108	maintaining fuel filters.....	369
filters		primary fuel filter	
charge filter	332	installing	370
installing	333	removing	369
removing.....	332	secondary fuel filter	
DEF supply module filter	377	installing	371
checking filter	377	removing	370
cleaning and inspecting filter	379	fuel specifications	294
installing filter	379	fuel tank	
removing filter	377	draining the fuel tank	401
DEF vent hose filter		filling the fuel tank.....	115
changing DEF vent hose filter.....	385	fuel/water separator	336
engine air filter		removing water from fuel system	336
		removing/installing fuel tank vent filter	375
		priming	371

INDEX

- function buttons 105
- fuse panel 423
- fuses
 - accessing fuses 420
 - checking and replacing 421–422
 - inspecting/replacing 125A main fuses 428
- G**
- gearboxes
 - engine
 - changing lubricant 327, 367
- glossary 27
- GPS automated steering systems 439
- ground speed control
 - troubleshooting 454
- ground speed lever
 - function group switches 71
 - header position six-way switch 72
 - header raise and lower rates 232
 - home, back, and select buttons 81
 - location 37
 - One-Touch-Return positions 74
 - reel and disc speed switch 73
 - reel position four-way switch 73
 - scroll knob, scroll wheel, and select button 80
- ground speed levers 69
- ground speed limit 130
- ground speeds 77
- GSL, *See* ground speed lever
- GVW
 - definition 27
- H**
- handholds
 - location 34
- hard joint
 - definition 27
- harvest performance tracker
 - fault codes
 - engine fault codes 514
 - windrower fault codes 468
 - faults and teltales 88
 - function buttons
 - F1 to F6 105
 - HPT display 67, 77
 - clearing fault codes 94
 - home, back, select buttons 81
 - main menu 83
 - menu icons 84
 - navigating the display 80
 - QuickMenu 82
 - screen layout 77
 - scroll knob, scroll wheel, select button 80
 - setting alarm volume 91
 - setting display brightness 90
 - setting display language and units 93
 - setting display time and date 92
 - setting up the display 90
 - soft keys 81
 - machine information
 - accessing header information 101
 - accessing performance information 103
 - accessing software information 102
 - accessing windrower information 100
 - run screen 1
 - auger headers 276
 - draper headers 257
 - rotary disc headers 283, 290
 - run screen 2
 - auger headers 277
 - draper headers 258
 - rotary disc headers 284, 291
 - run screen 3 138
 - run screen 4 128
 - settings
 - calibrating windrower and header 213
 - control locks 99
 - resetting to factory defaults 96
 - windrower tire size 98
 - symbols
 - definitions 109
 - viewing machine information 100
 - harvest performance tracker display
 - checking header settings 212
 - location 37
 - hazard lights 53, 56, 69
 - location 34
 - HDS
 - definition 27
 - header angles 227
 - header controls 70
 - console header buttons 75
 - deck shift/float presets 75
 - draper speed 76
 - DWA 76
 - GSL buttons 71
 - header position six-way switch 72
 - One-Touch-Return positions 74
 - reel and disc speed switch 73
 - reel position four-way switch 73
 - header drive reverse button 70
 - header engage/drive switch 70
 - header drive 225
 - specifications 30
 - header engage switch 70
 - header float 220
 - checking float 221

INDEX

float operating guidelines	222
float options with deck shift (D1X Series)	255
float options with deck shift (D1XL Series)	255
float options with fixed deck (R113 or R216 Rotary Disc Header)	281, 288
float options with fixed deck (R85)	281, 288
preset controls	75
removing and restoring float	224
setting float	222
header height	229
header hours	101
header information	77
header lift legs	
location	34
header operation	
center-link	
checking self-locking center-link hook	228
disengaging the header	225
engaging the header	225
header angles	
adjusting header angle	227
header drive	225
header float	
float operating guidelines	222
header height	229
knife/disc drive hydraulics	316
operating with a header	219
A40DX Auger Header	262
D1X Series Draper Header	234
D1XL Series Draper Header	234
header float	220
R113 or R216 Rotary Disc Header	285
R85 Rotary Disc Header	278
reel and draper hydraulics	316
reversing the header	226
header positions	71, 77
headers	
accessing information on the HPT	101
adjusting raise and lower rates	232
compatibility	30
D1X Series	
attaching header	
self-aligning hydraulic center-link	163
attaching to windrower	
connecting hydraulics	169
draper header supports	162
detaching from windrower	
units with hydraulic center-link	171
D1X Series Draper Headers	
attaching header	
non-self-aligning hydraulic center-link	163
D1XL Series	
attaching header	
non-self-aligning hydraulic center-link	163
with self-aligning hydraulic center-link	163
attaching to windrower	
connecting hydraulics	169
draper header supports	162
detaching from windrower	
units with hydraulic center-link	171
definition	27
detaching from windrowers	191
R113 Rotary Disc Header	
disc run screens	283, 290
R85 4.9 m (16 ft.) Rotary Disc	
attaching to windrower	
with self-alignment kit	200
without self-alignment kit	200
R85 4.9 m (16 ft.) Rotary Disc Header	
attaching to windrower	
connecting header hydraulics	206
R85 Rotary Disc Header	
disc run screens	283, 290
towing with windrower	145
headlights	52–53
aligning	406
heater shut-off valves	59
height	
operator's seat	41
hex keys	
definition	27
high beams	
switch	51
symbol	108
hoods	
closing	303
location	34
opening to lowest position	302
horns	66
horn button location	69
location	34
hp	
definition	27
HPT, <i>See</i> harvest performance tracker	
HVAC system	
A/C compressor	
coolant cycling	114
replacing belts	405
tensioning belts	326, 404
A/C condenser	313
A/C cover	
installing cover	399
removing cover	397
A/C evaporator	397
cleaning evaporator core	398
air distribution	59
fresh air intake filter	344
inspecting and cleaning	345
installing filter	346
removing filter	344

INDEX

heater shut-off valve.....	59
return air cleaner/filter	349
testing/troubleshooting	
cab air	455
hydraulic oil temperatures	128
hydraulic system	315
hydraulic oil cooler.....	316
knife/disc drive hydraulics	316
reel and draper hydraulics	316
traction drive hydraulics.....	316
hydraulics	
connecting	
A40DX Auger Headers	157
D1X Series Headers	169
D1XL Series Headers.....	169
R113 Rotary Disc Header.....	181
R216 Rotary Disc Header.....	181
R85 4.9 m (16 ft.) Rotary Disc Header.....	206
filters	
charge filter	332
installing	333
removing	332
part numbers	297
return oil filter	
installing	331
removing	330
fittings	
O-ring boss (ORB) adjustable	462
O-ring boss (ORB) non-adjustable	464
O-ring face seal (ORFS)	465
tapered pipe thread fittings.....	466
hydraulic hoses and lines.....	342
hydraulic oil	
checking and adding hydraulic oil	337
draining hydraulic oil.....	382
filling hydraulic oil.....	384
hydraulic safety	6
traction drive hydraulics.....	316
troubleshooting	450
warnings.....	315

I

ignition switch	67
location	37
inhibit status.....	77
ISC	
definition.....	27

J

JIC	
definition.....	27

K

knife	
definition.....	27
knife pressure	
viewing	257, 276–277
knife speed	269
A40DX Auger Headers	
adjusting knife alarm pressure	271
adjusting knife speed alarm	272
knife speed chart	269
D1X Series Draper Headers	
knife alarm pressure.....	251
knife speed alarm	252
setting knife speed.....	250
D1XL Series Draper Headers	
knife alarm pressure.....	251
knife speed alarm	252
setting knife speed.....	250
knife speed chart	249
viewing	257, 276–277

L

language	
setting on HPT	93
leveling the header	
D1X and D1XL Series Draper Headers.....	236
lighting	51
beacons.....	55
replacing lights.....	416
cab-forward mode	
field.....	51
road lights	52
engine-forward mode	
road lights	53
field lights	
cab-forward mode	51
flood lights	
adjusting front work lights (field).....	408
headlights	
aligning headlights (cab-forward).....	407
aligning headlights (engine-forward)	406
replacing headlight bulb (engine-forward).....	412
interior lights	
dome bulb.....	417
dome light assembly	418
LED lights	
optional lighting upgrade	439
replacing LED lights (deluxe cab).....	414
rear roof work lights	
adjusting rear roof work lights	409
rear swath lights	
adjusting rear swath lights.....	410
red and amber lights	

INDEX

replacing bulbs	415
troubleshooting	449
turn signal / hazard lights	56
turn signal indicators	419
work lights	
replacing halogen bulbs	411
locks	
lock and unlock swath compressor	261
lubricants	
adding to engine gearbox	343
changing in engine gearbox.....	327, 367
checking engine gearbox level	343
lubricating the windrower	
recommended fuel, fluids, and lubricants	293
lubrication.....	347
grease points and intervals	348
greasing procedure.....	348
lubricants/fluids/system capacities	295
lubricating wheel drive	
adding lubricant – 10 Bolt	364
adding lubricant – 12 bolt (optional)	365
changing wheel drive lubricant.....	328
changing wheel drive lubricant 12 Bolt (optional).....	329
checking lubricant levels	363
checking lubricant levels – 12 Bolt (optional)	363
storing lubricants and fluids	293
lumbar support	43
M	
maintenance and servicing	
A/C compressor belt	
replacing	405
tensioning	326, 403–404
break-in inspection schedule	298
break-in inspections	
procedures	323
break-in period	112
checking safety systems	372
engine interlock.....	374
operator presence system	372
cycling air conditioning compressor coolant.....	114
daily checks and maintenance	115
electrical system	317
batteries	386
module layout.....	317
electronic maintenance tool.....	301
engine	
air intake system	314
charge air cooling	312
engine belt	403
engine oil	
checking	117, 334
gearbox.....	343
general engine inspection	385
engine air filters.....	358
engine coolant.....	380
engine exhaust system	
inspecting.....	365
engine oil.....	356
filter part numbers	297
fuel system	
fuel filters.....	369
fuel, fluids, and lubricants.....	293
greasing the windrower.....	347
hydraulic oil	
checking and adding hydraulic oil	337
draining hydraulic oil	382
filling hydraulic oil.....	384
lighting.....	406
adjusting field/work/flood lights (front)	408
adjusting rear swath lights.....	410
adjusting roof work lights (rear)	409
aligning headlights (cab-forward).....	407
aligning headlights (engine-forward)	406
replacing beacon lights	416
replacing cabin dome bulb	417
replacing dome light assembly	418
replacing halogen bulbs	411
replacing headlight bulb (engine forward)	412
replacing LED lights (deluxe cab).....	414
replacing red and amber bulbs	415
replacing red tail lights	416
maintenance schedule	298
maintenance schedule/record	299
platform operation, <i>See</i> platforms	
preseason checks/annual service	113
safety.....	5
service intervals	
10 hours or daily.....	334
100 hours	349
1000 hours	375
2000 hours	380
250 hours or annually.....	356
50 hours.....	344
500 hours or annually.....	369
annual service	386
as required	401
steering link pivots	395
system overviews.....	307
air intake system	314
diesel exhaust fluid system	307
electrical system	317
engine cooling system	
twin-flow cooling system	309
hydraulic system.....	315
wheels and tires	
caster wheels	433
drive wheels	429

INDEX

<ul style="list-style-type: none"> maintenance indicator..... 77 maintenance platforms <ul style="list-style-type: none"> location 34 manuals <ul style="list-style-type: none"> engine owner’s manual 385 manual storage location 61 MDS <ul style="list-style-type: none"> definition 27 menu icons <ul style="list-style-type: none"> HPT 84 metric bolts <ul style="list-style-type: none"> torque specifications 459 mirrors <ul style="list-style-type: none"> location 34 	<ul style="list-style-type: none"> reverse in engine-forward mode..... 136 spin turn 137 stopping..... 137 engine starting 119 filling the fuel tank 115 One-Touch-Return..... 231 operating with a header 219 <ul style="list-style-type: none"> A40DX Auger Header..... 262 D1X Series Draper Header 234 D1XL Series Draper Header..... 234 header safety props 219 R113 or R216 Rotary Disc Header 285 R85 Rotary Disc Header 278 operational safety 111 overview 100 preseason checks/annual service 113 <ul style="list-style-type: none"> distributing A/C compressor coolant 114 shutting down the engine..... 125 operations..... 111 <ul style="list-style-type: none"> <i>See also</i> engine operation <i>See also</i> header operation header float 220 owner/operator responsibilities..... 107 symbols..... 108 operator presence system..... 39 <ul style="list-style-type: none"> checking 372 engine and transmission..... 39 header drive..... 39 operator’s seat adjustments..... 40 <ul style="list-style-type: none"> armrest 40 armrest angle 41 cushion extension fore-aft (deluxe cab)..... 45 cushion tilt (deluxe cab) 44 fore-aft isolator control 42 fore-aft position..... 42 heating/cooling switch (deluxe cooling)..... 46 lateral isolation (deluxe cab) 45 lumbar support..... 43 seat tilt..... 43 suspension and seat height 41 vertical dampener 44 operator’s station..... 37 <ul style="list-style-type: none"> AM/FM/CD/USB Bluetooth®-equipped radio..... 63 checking engine interlock 374 climate control system <ul style="list-style-type: none"> fan and temperature controls 60 console 37 engine controls..... 67 <ul style="list-style-type: none"> eco engine control (EEC) 68 header controls, <i>See</i> header controls horn 66 lighting..... 51 <ul style="list-style-type: none"> cab-forward – field..... 51 cab-forward – road 52 engine-forward – road..... 53
--	---

N

<ul style="list-style-type: none"> N-DETENT <ul style="list-style-type: none"> definition..... 27 n/a <ul style="list-style-type: none"> definition..... 27 NPT <ul style="list-style-type: none"> definition..... 27 nut <ul style="list-style-type: none"> definition..... 27

O

<ul style="list-style-type: none"> oil pressure 126 oils (engine) <ul style="list-style-type: none"> adding..... 118, 335, 357 checking level..... 117, 334 draining oil..... 356 replacing engine oil filter 357 One-Touch-Return 231 operating symbols 108 operating the windrower <ul style="list-style-type: none"> accessing header information..... 101 accessing performance information..... 103 accessing software information 102 accessing windrower information..... 100 adjusting header raise and lower rates..... 232 break-in period 112 daily checks..... 115 data <ul style="list-style-type: none"> run screen 3 – performance data..... 138 run screen 4 – cooling data..... 128 double windrowing..... 229 <ul style="list-style-type: none"> deck position 230 draper speed 230 driving the windrower <ul style="list-style-type: none"> forward in cab-forward mode 131 forward in engine-forward mode..... 134 reverse in cab-forward mode 133

INDEX

- tail / beacon lights 55
- turn signal / hazard lights 56
- location 34
- operator amenities
 - coat hook 61
 - manual storage 61
 - operator's console 61
 - window shades 61
- operator presence system 39, 372
 - engine and transmission 39
 - header drive 39
- rear view mirrors 58
- safety systems 372
- seat belts 48, 401
- steering column and wheel 50
- training seat 47
- windrower controls 69
- windshield wipers 57
- options and attachments 439
 - 360° night vision LED lighting 439
 - automated steering systems 439
 - ballast packages for draper headers 443
 - booster spring kit (external) 440
 - center-link lifter 442
 - conversion kit for disc ready to disc, auger, and draper ready 440
 - double booster spring kit – external 441
 - double windrow attachment (DWA) 441
 - DWA shut-off kit 441
 - single-sided mud caster wheel 444
 - swath compressor 442
 - transport
 - towing harness 444
 - weight box 444
 - windrower lighting upgrade (LED) 439
- ORB
 - definition 27
- ORFS
 - definition 27
- owner/operator responsibilities 107
- P**
 - park 69
 - performance data 138
 - platforms 304
 - adjusting platform 305
 - closing platform 304
 - opening platform 304
 - precleaners
 - location 34
 - predelivery checks
 - tire pressure 338
 - preseason checks 113
 - pressurized coolant tank
 - inspecting pressurized coolant tank cap 310
 - priming
 - fuel system 371
 - product overview 27
- Q**
 - QuickMenu system 82
- R**
 - R Series headers
 - definition 27
 - R113 or R216 rotary disc headers
 - connecting hydraulics 181
 - R113 or R216 Rotary Disc Headers
 - operating 285
 - R113 Rotary Disc Header
 - attaching header 175
 - R113 Rotary Disc Headers
 - detaching header 191
 - disc run screens 283, 290
 - run screen 1 283, 290
 - run screen 2 284, 291
 - disc speed 285
 - adjusting disc pressure alarm 279, 286
 - setting disc speed 285
 - disc speed switch 73
 - header float
 - float options with fixed deck 281, 288
 - R2 SP Series
 - definition 27
 - R216 Rotary Disc Header
 - connecting hydraulics 181
 - R216 Rotary Disc Headers
 - detaching header 196
 - R216 SP
 - attaching header 175
 - R85 4.9 m (16 ft.) Rotary Disc Header
 - attaching to windrower
 - connecting header hydraulics 206
 - R85 Rotary Disc Headers
 - attaching to windrower
 - hydraulic center-link 200
 - detaching from windrower 208
 - disc run screens 283, 290
 - run screen 1 283, 290
 - run screen 2 284, 291
 - disc speed 285
 - disc pressure alarm 279, 286
 - setting disc speed 278, 285
 - disc speed switch 73
 - header float
 - float options with fixed deck 281, 288

INDEX

- operating on windrower..... 278
- radios
 - activating Bluetooth®..... 64
 - AM/FM/CD/USB Bluetooth®-equipped radio..... 63
 - pairing a Bluetooth® device 65
- rear view mirrors..... 58
- reel
 - D1X and D1XL Series Draper Headers
 - adjusting reel alarm pressure..... 241
 - troubleshooting 450
 - reel alarm pressure
 - A40DX Auger Headers..... 267
 - D1X and D1XL Series Draper Headers..... 241
 - reel fore-aft position
 - viewing 258
 - reel height
 - viewing 258
 - reel position
 - four-way switch 73
 - reel pressure
 - viewing 257, 276
 - reel speed
 - A40DX Auger Headers
 - adjusting 262
 - setting in auto mode 262
 - setting in manual mode 264
 - D1X and D1XL Series Draper Headers
 - adjusting 238
 - setting in auto mode 238
 - setting in manual mode 240
 - viewing 257–258, 276–277
 - reel speed control kit 262
 - references
 - torque specifications 459
 - relay module 423
 - relays
 - replacing 422
 - return oil filter
 - installing..... 331
 - removing..... 330
 - reverse 70
 - symbol 108
 - reversing
 - in cab-forward mode 133
 - in engine-forward mode..... 136
 - reversing the header..... 226
 - road lights..... 52
 - aligning headlights 406
 - location 34
 - switch 51
 - symbol 108
 - RoHS
 - definition..... 27
 - roof connectors
 - welding precautions 9
 - rpm
 - definition..... 27
 - S**
 - SAE
 - definition..... 27
 - safety 1
 - battery safety 8
 - checking engine interlock 374
 - checking operator presence system..... 372
 - engine safety..... 13
 - engine electronics..... 14
 - high-pressure rail..... 13
 - general safety..... 3
 - hydraulic safety 6
 - maintenance safety 5
 - operational safety 111
 - safety alert symbols..... 1
 - safety sign decals 15
 - installing decals 15
 - interpreting decals 18
 - sign location..... 16
 - signal words..... 2
 - tire safety 7
 - welding precautions 9
 - safety systems 372
 - screen brightness 90
 - screen layouts
 - HPT 77
 - screws
 - definition..... 27
 - scroll wheel 71
 - SDD
 - definition..... 27
 - seat belts 48
 - maintaining seat belts..... 401
 - serial numbers
 - engine serial number location vii
 - windrower serial number location..... vii
 - shutting down the engine 125
 - SKD
 - definition..... 27
 - Slow Speed Transport option..... 145
 - soft joints
 - definition..... 27
 - soft keys 81
 - software 102
 - specifications
 - battery specification 386
 - filter part numbers 297
 - fuel..... 294
 - torque specifications 459
 - windrower dimensions..... 33
 - windrower specifications..... 30

INDEX

spin turning.....	137	hydraulic oil	128, 284, 291
spm		seat	46
definition.....	27	tension	
starting the engine	119	definition.....	27
steering		TFFT	
adjustments		definition.....	27
steering column.....	50	throttle.....	67, 70
steering wheel.....	50	location	37
automated steering systems (option).....	439	time	
checking steering link pivots.....	395	setting on HPT	92
troubleshooting	454	tires, <i>See</i> wheels and tires	
stopping	137	torque	
storing windrowers	150	definition.....	27
supply module		torque angles	
cleaning and inspecting filter.....	379	definition.....	27
installing filter	379	torque specifications.....	459
removing filter.....	377	metric bolt specifications.....	459
suspension		bolting into cast aluminum	461
operator's seat	41	O-ring boss (ORB) hydraulic fittings – adjustable.....	462
swath compressors	75	O-ring boss (ORB) hydraulic fittings – non-	
description.....	259	adjustable	464
lock and unlock.....	261	O-ring face seal (ORFS) fittings.....	465
operating.....	259	tapered pipe thread fittings	466
raising.....	76	torque-tension	
switches		definition.....	27
auxiliary lift	76	towing harness	444
disc speed.....	71, 73	towing headers	145
ground speed lever.....	71	preparing.....	146
header engage.....	70	weight box.....	444
header position	72	towing windrower	148
lighting	51	engaging and disengaging final drives	149
One-Touch-Return switches	71	traction drive	
reel position.....	71	specifications	30
reel position four-way switch	73	troubleshooting	452
reel speed.....	71, 73	training seats	47
reel speed switch	73	Trimble® automated steering systems	439
select button.....	80	troubleshooting	
select switch	71, 80	batteries.....	449
shift switch	71, 80	cab air.....	455
symbols		electrical.....	449
definitions	108	engine.....	445
HPT	109	engine start.....	123
HPT menu icons.....	84	header drive.....	451
windrower operating symbols	108	hydraulics	450
T		lighting.....	449
taillights.....	52–53, 55	operator's station	458
location	34	reel.....	450
telltails	77	steering and ground speed control	454
temperatures		traction drive	452
cab	59–60	turn signals	449
engine.....	125	wheels	452
engine air intake	128	turn signals	52–53, 56, 69
engine coolant.....	128	indicators	419
		location	34
		status.....	77

INDEX

symbol	108
troubleshooting	449
turning the windrower	137
twin-flow cooling system	309

U

UCA	
definition	27
ULSD	
definition	27
units of measurement	
setting on HPT	93

W

walking beams	
adjusting caster tread width	433
location	34
maximum width	30
tightening bolts	325
washers	
definition	27
water	
removing from fuel system	336
WCM	
definition	27
weight boxes	139, 142, 145, 444
welding precautions	9
wheel motor connectors	
welding precautions	9
wheels and tires	
caster wheels	433
adjusting caster tread width	433
caster wheel nut torque	324
installing forked caster wheel	435
location	34
lowering caster wheel (all)	437
raising caster wheel (all)	437
removing forked caster wheel	436
tightening anti-shimmy dampener	325
checking tire pressure	338
drive wheels	
installing drive wheels	431
location	34
lowering drive wheels	433
raising drive wheel	429
removing drive wheel	430
tightening drive wheel nuts	323
safety	7
setting tire size in harvest performance tracker	98
tires	
checking pressure	338
tire options	30

troubleshooting	452
wheel drive	
adding lubricant – 10 Bolt	364
adding lubricant – 12 bolt (optional)	365
changing lubricant	328
changing lubricant 12 Bolt (optional)	329
checking lubricant levels	363
checking lubricant levels – 12 Bolt (optional)	363
windrower faults	
fault codes	468
faults and telltales	88
windrowers	
definition	27
windshield wipers	57
location	34
symbol	108
work lights	52–53

Lubricants, Fluids, and System Capacities

Table .11 System Capacities

Lubricant/Fluid	Location	Description	Capacity
Diesel exhaust fluid (DEF)	Diesel exhaust fluid tank	Must meet ISO 22241 requirements.	28 liters (7.5 U.S. gallons)
Grease	As required unless otherwise specified	SAE multi-purpose high temperature extreme pressure (EP2) performance with 1% max molybdenum disulphide (NLGI Grade 2) lithium base	As required unless otherwise specified
Diesel fuel	Fuel tank	Ultra low sulphur diesel (ULSD) Grade No. 2, or ULSD Grade No. 1 and 2 mix ³⁰ ; refer to 5.1.2 Fuel Specifications, page 294 for more information	518 liters (137 U.S. gallons)
Hydraulic oil	Hydraulic reservoir	Single grade transmission/hydraulic fluid (THF) Recommend Viscosity: <ul style="list-style-type: none"> 60.1 cSt @ 40°C 9.5 cSt @ 100°C Recommended brands: <ul style="list-style-type: none"> AGCO Power Fluid 821XL Case HY-TRAN ULTRACTION John Deere Hy-Gard J20C Petro-Canada DURATRAN 	60 liters (15.8 U.S. gallons) ³¹
Gear lubricant	Gearbox	SAE 75W-140 or 80W-140, API service class GL-5 fully synthetic gear lubricant (SAE J2360 preferred)	2.3 liters (2.4 U.S. quarts)
Gear lubricant	Standard Wheel drive	SAE 75W-140 or 80W-140, API service class GL-5 fully synthetic gear lubricant (SAE J2360 preferred)	1.4 liters (1.5 U.S. quarts)
Gear lubricant	High Torque Wheel drive	SAE 85W-140, API service class GL-5 fully synthetic gear lubricant	4.5 liters (4.8 U.S. quarts)
Antifreeze	Engine cooling system	ASTM D-6210 and Fleetguard ES Compleat®	33 liters (8.7 U.S. gallons) ³²
Engine oil	Engine oil pan	SAE 15W-40 compliant with SAE specs for API Class SJ and CJ-4 engine oil	14 liters (14.8 U.S. quarts)
Air conditioning refrigerant	Air conditioning system	R134A	2.38 kg (5.25 lb.)

30. Optional when operating temperature is below 0°C (32°F).

31. Denotes capacity of a dry system. Refill capacity is 58 liters (15 U.S. gallons).

32. Equal parts with water; high quality, soft, deionized or distilled water as recommended by Supplier.

Table .11 System Capacities (continued)

Lubricant/Fluid	Location	Description	Capacity
Air conditioning refrigerant oil	Air conditioning system total capacity	PAG SP-15	240 cc (8.1 fl. oz.)
Windshield washer fluid	Windshield washer fluid tank	SAE J942 compliant	4 liters (1 U.S. gallon)

MacDon Industries Ltd.

680 Moray Street
Winnipeg, Manitoba
Canada R3J 3S3
t. (204) 885-5590 f. (204) 832-7749

MacDon, Inc.

10708 N. Pomona Avenue
Kansas City, Missouri
United States 64153-1924
t. (816) 891-7313 f. (816) 891-7323

MacDon Australia Pty. Ltd.

A.C.N. 079 393 721
P.O. Box 103 Somerton, Victoria, Australia
Australia 3061
t.+61 3 8301 1911 f.+61 3 8301 1912

MacDon Brasil Agribusiness Ltda.

Rua Grã Nicco, 113, sala 404, B. 04
Mossunguê, Curitiba, Paraná
CEP 81200-200 Brasil
t. +55 (41) 2101-1713 f. +55 (41) 2101-1699

LLC MacDon Russia Ltd.

123317 Moscow, Russia
10 Presnenskaya nab, Block C
Floor 5, Office No. 534, Regus Business Centre
t. +7 495 775 6971 f. +7 495 967 7600

MacDon Europe GmbH

Hagenauer Strasse 59
65203 Wiesbaden
Germany

CUSTOMERS

MacDon.com

DEALERS

Portal.MacDon.com

Trademarks of products are the marks of their
respective manufacturers and/or distributors.

Printed in Canada