

**A30-S and A30-D
Pull-Type Mower Conditioners**

**A30-S, A30-D and A40-D
Self-Propelled Auger Headers**

OPERATOR'S MANUAL

Part #169000 Rev. E

\$15



MACDON A40-D SELF-PROPELLED AUGER HEADER



MACDON A30-D PULL-TYPE MOWER CONDITIONER

1 INTRODUCTION

This instructional manual describes the operating and maintenance procedures for the Model A30-S, A30-D, and A40-D Auger Headers, including a Grass Seed version. Your new Auger Header is designed to cut, condition, and lay in windrows a wide variety of grasses and hay crops. The available Double Knife feature expands the operational envelope, especially in heavier crops.

MODEL *	DESCRIPTION	CONFIGURATION	KNIFE	SIZE (FT)	FEATURES
A30-S	A - Auger Header with Conditioner	Self-Propelled ** Or Pull-Type	S - Single	14 and 16	Hydraulic Drive
A30-D	A - Auger Header with Conditioner	Pull-Type Only	D - Double	14, 16 and 18	Hydraulic Drive
A40-D	A - Auger Header with Conditioner	40 - Self-Propelled **		14, 16, and 18	Separate Hydraulic Auger, Knife and Reel Drives, Grass Seed Option.

* Model availability depends on Dealer affiliation

** When attached to a MacDon M-Series Windrower.

CAREFULLY READ ALL THE MATERIAL PROVIDED BEFORE ATTEMPTING TO UNLOAD, ASSEMBLE, OR USE THE MACHINE.

Use this manual as your first source of information about the machine. If you follow the instructions given here, your Header/Mower Conditioner will work well for many years. A Parts Catalog is also supplied with your new Header/Mower Conditioner. If you require more detailed service information, see your Dealer for availability of a Service Manual.

Use the Table of Contents and the Index to guide you to specific areas. Study the Table of Contents to familiarize yourself with how the material is organized. Keep this manual handy for frequent reference, and to pass on to new Operators or Owners. Contact your Dealer if you need assistance, information, or additional copies of this manual.

RECORD THE SERIAL NUMBERS OF THE HEADER AND ARTICULATING POWER TONGUE (APT) IN THE SPACES BELOW.

HEADER SERIAL NUMBER:

APT SERIAL NUMBER (PULL-TYPE):

Serial Number plate is located at the top of the left hand end frame.

Serial Number plate is located at the top aft end of the APT.

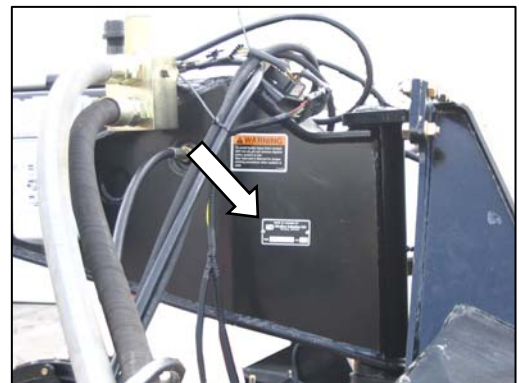
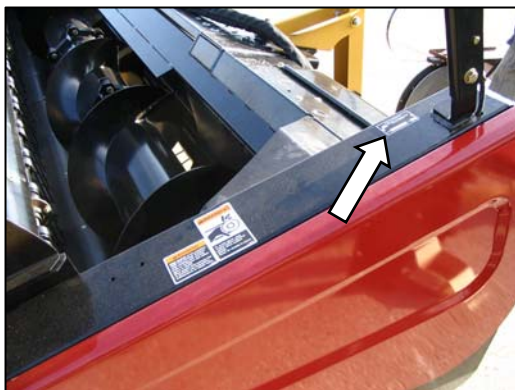

Published: August, 2012

PTO SPEED: 1000 RPM

TABLE OF CONTENTS

Section/Title	Page
1 INTRODUCTION	1
2 SAFETY	6
2.1 SAFETY ALERT SYMBOL	6
2.2 SIGNAL WORDS	6
2.3 SAFETY SIGNS	6
2.3.1 <i>Safety Sign Installation</i>	6
2.3.2 <i>2-Panel Safety Sign Locations: Pull-Type</i>	7
2.3.3 <i>2-Panel Safety Sign Locations: Self-Propelled</i>	10
2.4 GENERAL SAFETY	12
3 DEFINITIONS	14
4 COMPONENT IDENTIFICATION	15
4.1 PULL-TYPE	15
4.2 SELF-PROPELLED	18
5 SPECIFICATIONS	19
5.1 PULL-TYPE HEADERS	19
5.2 SELF-PROPELLED HEADERS	21
6 OPERATION	23
6.1 OWNER/OPERATOR RESPONSIBILITIES	23
6.2 OPERATIONAL SAFETY	23
6.3 TRACTOR SETUP: PULL-TYPE	24
6.3.1 <i>Tractor Requirements</i>	24
6.3.2 <i>Drawbar Adjustment</i>	24
6.3.3 <i>Drawbar Hitch Set-Up</i>	25
6.3.4 <i>3 Point Hitch (Cat. II, III or IIIN) Set-Up</i>	26
6.4 MOWER CONDITIONER / TRACTOR HOOKUP: PULL-TYPE	27
6.4.1 <i>Drawbar Hook-Up</i>	27
6.4.2 <i>3 Point Hitch (Cat. II, III, or IIIN) Hook-Up</i>	28
6.4.3 <i>Hydraulic Connections</i>	29
6.5 MOWER CONDITIONER / TRACTOR UNHOOK: PULL-TYPE	30
6.5.1 <i>Drawbar Hitch Unhook</i>	30
6.5.2 <i>3-Point Hitch Unhook</i>	32
6.6 HEADER ATTACHMENT: SELF-PROPELLED	33
6.6.1 <i>A30-S</i>	33
6.6.2 <i>A40-D</i>	35
6.6.3 <i>Configure Reverser Valve Jumper Hose</i>	44
6.7 HEADER DETACHMENT: SELF-PROPELLED	46
6.7.1 <i>A30-S Detachment</i>	46
6.7.2 <i>A40-D Detachment</i>	47
6.8 TRANSPORTING MOWER CONDITIONER	49
6.8.1 <i>Self-Propelled</i>	49
6.8.2 <i>Pull-Type: Towing</i>	49
6.8.3 <i>Pull-Type: Flatbed</i>	52
6.9 BREAK-IN PERIOD	57
6.10 PRE-SEASON CHECK	57
6.11 DAILY START-UP CHECK	57
6.12 SHUTDOWN PROCEDURE	58
6.13 ENGAGING THE PTO: PULL-TYPE	58

TABLE OF CONTENTS

Section/Title	Page
6.14 LIFT CYLINDER LOCK-OUTS.....	58
6.14.1 Self-Propelled.....	58
6.14.2 Pull-Type.....	58
6.15 STEERING: PULL-TYPE	59
6.15.1 Right Side Operation: Pull-Type	59
6.15.2 Left Side Operation: Pull-Type.....	60
6.15.3 Avoiding Obstacles	60
6.15.4 Square Corners.....	60
6.15.5 180 Degree Turn	61
6.16 UNPLUGGING THE HEADER / MOWER CONDITIONER	62
6.16.1 Unplugging Conditioner: Pull-type	62
6.16.2 Unplugging Conditioner: Self-Propelled - A30-S.....	62
6.16.3 Unplugging Sickle	62
6.17 HEADER OPERATION	63
6.17.1 Lean Bar Position.....	63
6.17.2 Auger Speed	64
6.17.3 Reel Speed.....	65
6.17.4 Auger Position.....	66
6.17.5 Reel Position	75
6.17.6 Tine Aggressiveness Adjustment.....	79
6.17.7 Reel Tine to Header Pan Clearance	80
6.17.8 Cutting Height	80
6.17.9 Header Angle	81
6.17.10 Header Flotation.....	82
6.17.11 Feed Pan / Rock-Drop Tine Position	83
6.17.12 Hay Conditioner	84
6.17.13 Roll Tension	87
6.17.14 Forming Shields	88
6.17.15 Tall Crop Dividers.....	90
6.17.16 Ground Speed.....	91
6.17.17 Grass Seed Windrowing	92
6.17.18 Recommended Settings.....	94
6.18 HAYING TIPS.....	95
6.18.1 Curing.....	95
6.18.2 Topsoil Moisture.....	95
6.18.3 Weather and Topography	95
6.18.4 Windrow Characteristics	95
6.18.5 Driving On Windrow	95
6.18.6 Raking and Tedding.....	95
6.18.7 Chemical Drying Agents.....	95
6.19 STORAGE	96
7 MAINTENANCE AND SERVICING	97
7.1 PREPARATION FOR SERVICING	97
7.2 RECOMMENDED SAFETY PROCEDURES.....	97
7.3 MAINTENANCE SPECIFICATIONS	98
7.3.1 Recommended Torques.....	98
7.3.2 Recommended Fluids and Lubricants	101
7.3.3 Conversion Chart	102
7.4 DRIVESHIELDS	103
7.5 LIFT CYLINDER LOCK-OUTS.....	103
7.5.1 Self-Propelled.....	103
7.5.2 Pull-Type	103

TABLE OF CONTENTS

Section/Title	Page
7.6 LUBRICATION	104
7.6.1 Greasing Procedure	104
7.6.2 Lubrication Points.....	104
7.6.3 Oiling	114
7.6.4 Sealed Bearing Installation	116
7.7 HYDRAULICS	117
7.7.1 Hydraulics: Self-Propelled.....	117
7.7.2 Hydraulics: Pull-Type	117
7.7.3 Hoses and Lines	118
7.8 SICKLE AND SICKLE DRIVE	119
7.8.1 Sickle Section Replacement	119
7.8.2 Sickle Removal.....	119
7.8.3 Sickle Installation	120
7.8.4 Sickle Head Bearing Removal	120
7.8.5 Sickle Head Bearing Installation	120
7.8.6 Spare Sickle	121
7.8.7 Sickle Guards.....	121
7.8.8 Sickle Hold-Downs.....	126
7.8.9 Sickle Drive Belt: A30-S.....	128
7.8.10 Sickle Drive Belts: A30-D.....	130
7.8.11 Sickle Drive Belts: A40-D.....	135
7.8.12 Sickle Drive Timing Adjustment	139
7.8.13 Sickle Drive Box.....	141
7.9 REEL AND REEL DRIVE: A30-S, A30-D.....	144
7.9.1 Reel Drive Chain: A30-S, A30-D.....	144
7.9.2 Reel Drive Belts: A30-S, A30-D.....	145
7.9.3 Reel Tines and Tine Bar Bearings: A30-S, A30-D.....	146
7.10 REEL AND REEL DRIVE: A40-D.....	148
7.10.1 Reel Drive: A40-D	148
7.10.2 Reel Tines and Tine Bar Bearings: A40-D.....	148
7.11 AUGER AND AUGER DRIVE: A30-S, A30-D.....	153
7.11.1 Auger Drive Chain: A30-S.....	153
7.11.2 Auger Drive Chain: A30-D.....	154
7.11.3 Auger Drive Belt: A30-S.....	155
7.11.4 Auger Drive Belts: A30-D.....	156
7.11.5 Auger Pans.....	157
7.11.6 Rubber Fingers.....	157
7.11.7 Stripper Bars	157
7.12 AUGER AND AUGER DRIVE: A40-D.....	158
7.13 CONDITIONER	159
7.13.1 Changing Gearbox Oil.....	159
7.13.2 Forming Shield Removal.....	159
7.13.3 Disassemble Forming Shield	160
7.13.4 Assemble Forming Shield	160
7.13.5 Install Forming Shield.....	160
7.13.6 Hydraulic Drive Motor Removal: All Models.....	161
7.13.7 Hydraulic Drive Motor Installation: All Models.....	161
7.13.8 Gearbox Removal: A30-S.....	162
7.13.9 Gearbox Installation: A30-S	163
7.13.10 Gearbox Removal: A30-D.....	165
7.13.11 Gearbox Installation: A30-D.....	167
7.13.12 Gearbox Removal: A40-D.....	169
7.13.13 Gearbox Installation: A40-D.....	170

TABLE OF CONTENTS

Section/Title	Page
7.14 WHEELS, TIRES, AND HITCH: PULL-TYPE	172
7.14.1 Wheel Bolts	172
7.14.2 Wheel Removal.....	172
7.14.3 Wheel Installation.....	172
7.14.4 Tire Inflation.....	173
7.15 SKID SHOE WEAR PLATE REPLACEMENT	174
7.16 GAUGE ROLLERS.....	175
7.17 ELECTRICAL	175
7.18 MAINTENANCE SCHEDULE	176
7.18.1 Self-Propelled Mower Conditioner	176
7.18.2 Pull-Type Mower Conditioner.....	178
8 TROUBLESHOOTING.....	180
8.1 WINDROWER PERFORMANCE	180
8.2 MECHANICAL.....	183
9 OPTIONS AND ATTACHMENTS.....	185
9.1 HYDRAULIC HEADER ANGLE KITS: PULL-TYPE	185
9.2 ADDITIONAL SKID SHOES.....	185
9.3 GAUGE ROLLER KIT	185
9.4 REPLACEMENT REEL BAT KITS: A30-S, A30-D	185
9.5 STUB GUARD CONVERSION KIT	185
9.6 TALL CROP DIVIDER KIT	185
10 UNLOADING AND ASSEMBLY.....	186
INDEX	187

SECTION 2 SAFETY

2 SAFETY

2.1 SAFETY ALERT SYMBOL



This safety alert symbol indicates important safety messages in this manual and on safety signs on the machine.

This symbol means:

**ATTENTION!
BECOME ALERT!
YOUR SAFETY IS INVOLVED!**

Carefully read and follow the safety message accompanying this symbol.

WHY IS SAFETY IMPORTANT TO YOU?

**ACCIDENTS DISABLE AND KILL.
ACCIDENTS COST.
ACCIDENTS CAN BE AVOIDED.**

2.2 SIGNAL WORDS

Note the use of the signal words DANGER, WARNING, and CAUTION with safety messages. The appropriate signal word for each message has been selected using the following guidelines:



DANGER

Indicates an imminently hazardous situation that, if not avoided, will result in death or serious injury.



WARNING

Indicates a potentially hazardous situation that, if not avoided, could result in death or serious injury. It is also used to alert against unsafe practices.



CAUTION

Indicates a potentially hazardous situation that, if not avoided, may result in minor or moderate injury. It is also used as a reminder of good safety practices.

2.3 SAFETY SIGNS

- The safety signs appear on the header/mower conditioner at the locations shown on pages 7 to 11.
- Keep safety signs clean and legible at all times.
- Replace safety signs that are missing or become illegible.
- If original parts on which a safety sign was installed are replaced, be sure the repair part also bears the current safety sign.
- Safety signs are available from your Dealer Parts Department.

2.3.1 Safety Sign Installation

- a. Be sure the installation area is clean and dry.
- b. Decide on the exact location before you remove the decal backing paper.
- c. Remove the smaller portion of the split backing paper.
- d. Place the sign in position, and slowly peel back the remaining paper, smoothing the sign as it is applied.
- e. Small air pockets can be smoothed out or pricked with a pin.

SECTION 2 SAFETY

2.3.2 2-Panel Safety Sign Locations: Pull-Type



A #174632 - Both sides

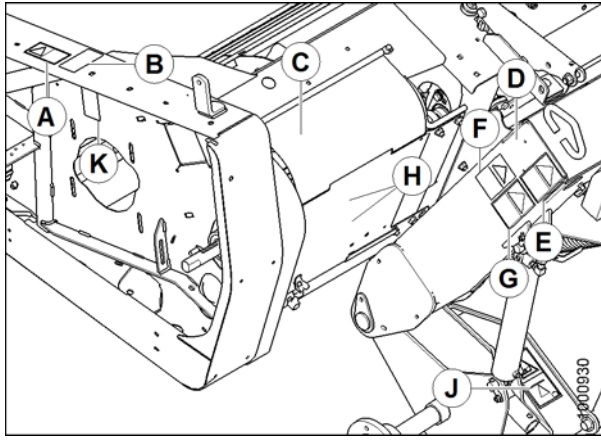

H #36651 and or 194521 - Drivelines

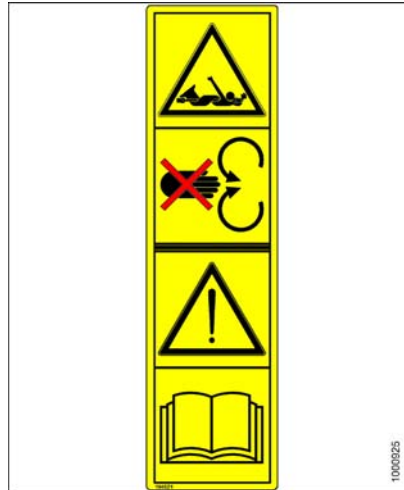

G #194462
169000 / 169040



J #171279 - Both sides



B and K #184422 - Both sides



C #184385



D #113482



E #194464



F #174436

SECTION 2 SAFETY

2-Panel Safety Sign Locations: Pull-Type (cont'd)

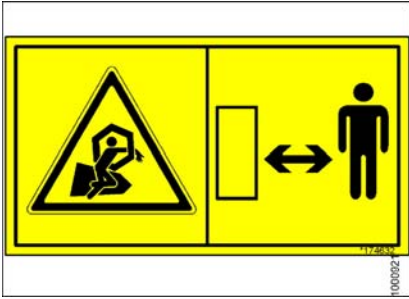

A #174632 - Both sides



B and F #184422 - Both sides

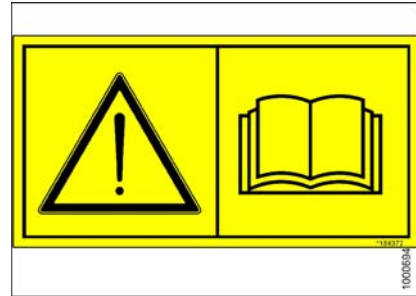

C #184372

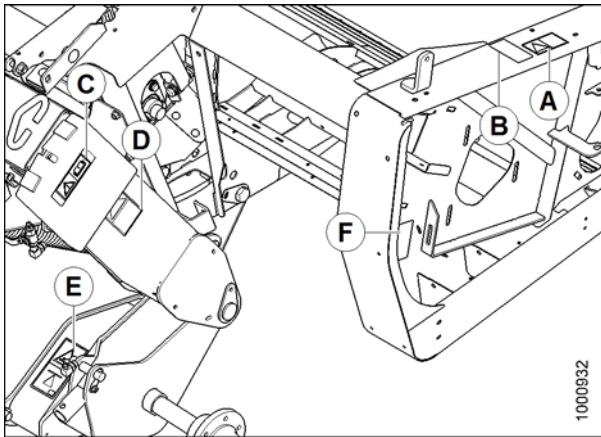

E #171279 - Both sides



D #194462

SECTION 2 SAFETY

2-Panel Safety Sign Locations: Pull-Type (cont'd)

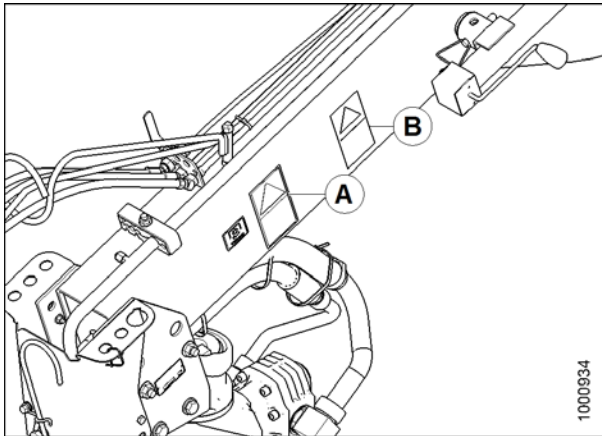

A #194464



B #174436

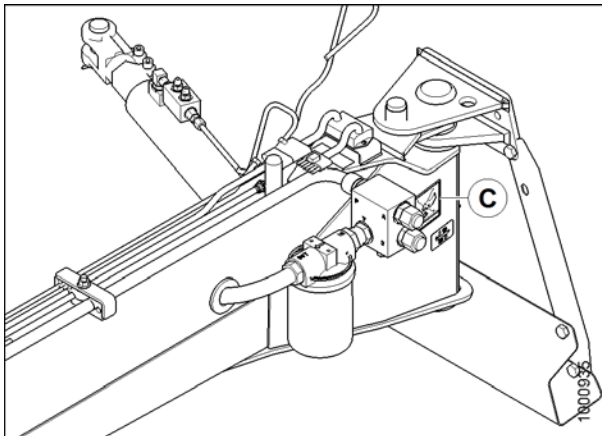

C #171281 - Both sides

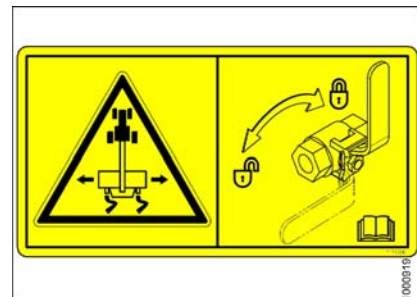
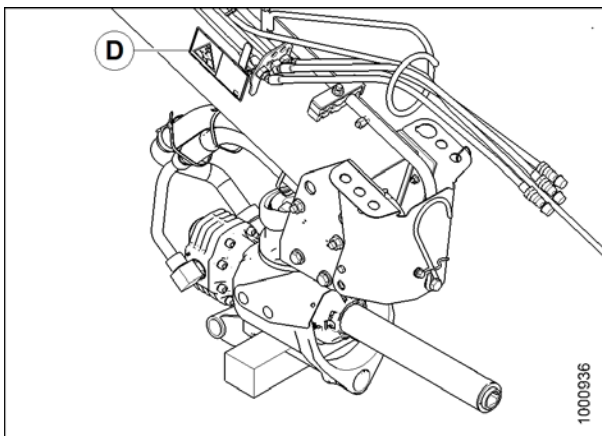

D #171280

SECTION 2 SAFETY

2.3.3 2-Panel Safety Sign Locations: Self-Propelled



A #174632 - Both sides

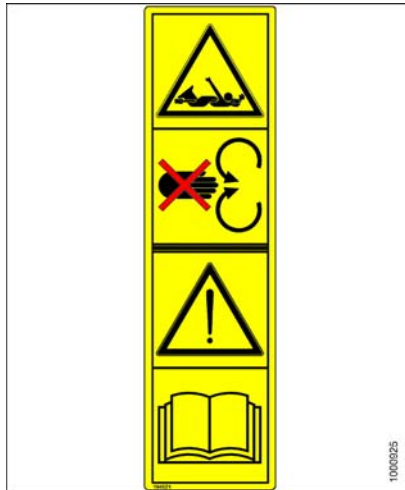
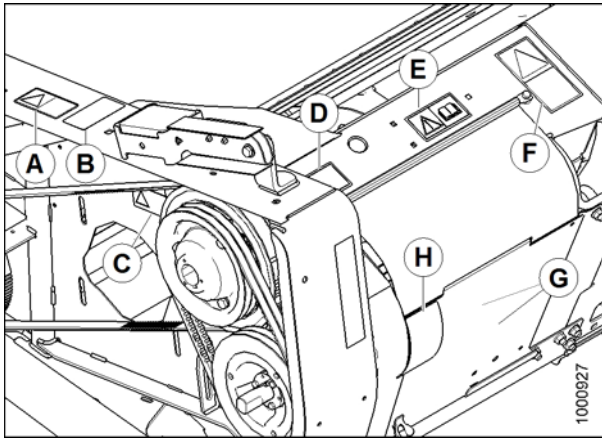

G #36651 and or 194521 - Drivelines



B and C #184422 - Both sides



D #174474

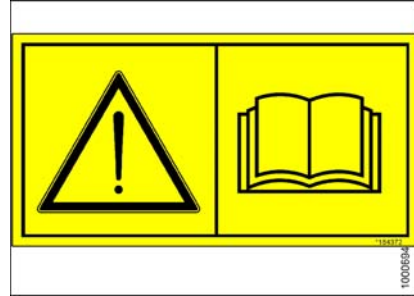

E-#184372



F #194464



H #184385

SECTION 2 SAFETY

2-Panel Safety Sign Locations: Self-Propelled (cont'd)

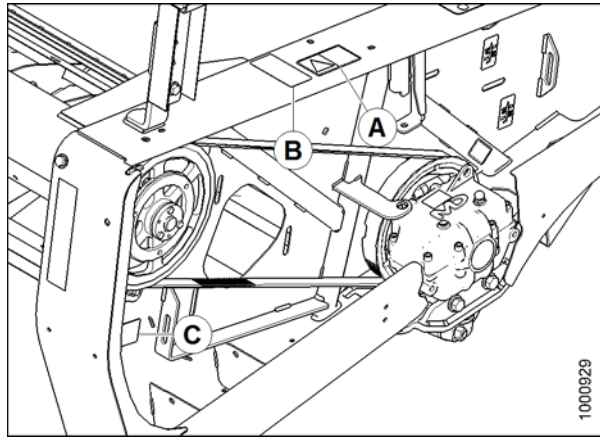

A #174632 - Both sides



B and C #184422 - Both sides

SECTION 2 SAFETY

2.4 GENERAL SAFETY



CAUTION

The following are general farm safety precautions that should be part of your operating procedure for all types of machinery.

- Protect yourself.
- When assembling, operating and servicing machinery, wear all the protective clothing and personal safety devices that **COULD** be necessary for the job at hand. Don't take chances.
- You may need:

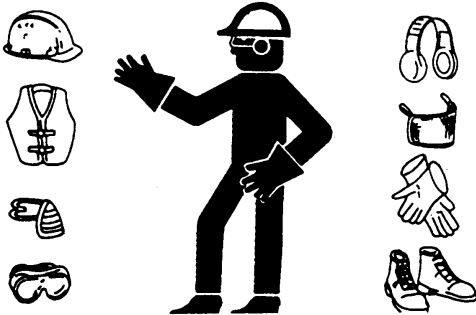

- a hard hat.
- protective shoes with slip resistant soles.
- protective glasses or goggles.
- heavy gloves.
- wet weather gear.
- respirator or filter mask.

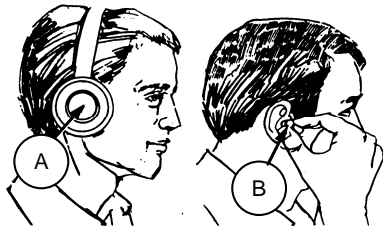

- hearing protection. Be aware that prolonged exposure to loud noise can cause impairment or loss of hearing. Wearing a suitable hearing protective device such as ear muffs (A) or ear plugs (B) protects against objectionable or loud noises.



- Provide a first-aid kit for use in case of emergencies.
- Keep a fire extinguisher on the machine. Be sure the extinguisher is properly maintained and be familiar with its proper use.
- Keep young children away from machinery at all times.
- Be aware that accidents often happen when the Operator is tired or in a hurry to get finished. Take the time to consider the safest way. Never ignore warning signs of fatigue.
- Wear close-fitting clothing and cover long hair. Never wear dangling items such as scarves or bracelets.
- Keep hands, feet, clothing and hair away from moving parts. Never attempt to clear obstructions or objects from a machine while the engine is running.

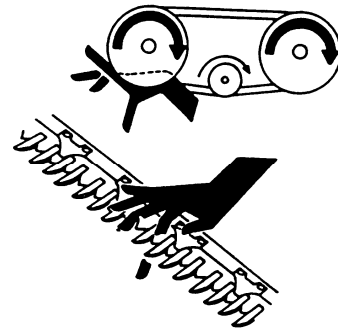

- Keep all shields in place. Never alter or remove safety equipment. Make sure the driveline guards can rotate independently of the shaft, and can telescope freely.

(continued next page)

SECTION 2 SAFETY

- Use only service and repair parts made or approved by the equipment manufacturer. Substituted parts may not meet strength, design, or safety requirements.
- Do not modify the machine. Unauthorized modifications may impair the function and/or safety and affect machine life.
- Stop engine, and remove key from ignition before leaving Operator's seat for any reason. A child or even a pet could engage an idling machine.



- Keep the area used for servicing machinery clean and dry. Wet or oily floors are slippery. Wet spots can be dangerous when working with electrical equipment. Be sure all electrical outlets and tools are properly grounded.
- Use adequate light for the job at hand.
- Keep machinery clean. Do not allow oil or grease to accumulate on service platforms, ladders or controls. Clean machines before storage.
- Never use gasoline, naphtha or any volatile material for cleaning purposes. These materials may be toxic and/or flammable.
- When storing machinery, cover sharp or extending components to prevent injury from accidental contact.

SECTION 3 DEFINITIONS

3 DEFINITIONS

The following terms may be used in this manual:

TERM	DEFINITION
API	American Petroleum Institute
APT	Articulating Power Tongue
ASTM	American Society Of Testing And Materials
Cab-Forward	Windrower operation with the Operator and cab facing in the direction of travel.
Center-link	A hydraulic cylinder or turnbuckle type link between header and the machine that tilts the header.
Engine-Forward	Windrower operation with the Operator and engine facing in the direction of travel.
Header or Auger Header	A machine that cuts and conditions hay, and is attached to a windrower.
Mower Conditioner	A machine that cuts and conditions hay, and is pulled by an agricultural tractor.
PTO	Power Take-Off
rpm	Revolutions Per Minute
SAE	Society Of Automotive Engineers
Self-propelled Windrower	Self-propelled machine consisting of a power unit with a header and conditioner.
Sickle or Knife	A cutting device which uses a reciprocating cutter.
Tractor	Agricultural-type tractor.
Truck	A four-wheel highway/road vehicle weighing no less than 7500 lb (3400 kg).
Windrower	Power unit of a self-propelled auger header.

SECTION 4 COMPONENTS

4 COMPONENT IDENTIFICATION

4.1 PULL-TYPE

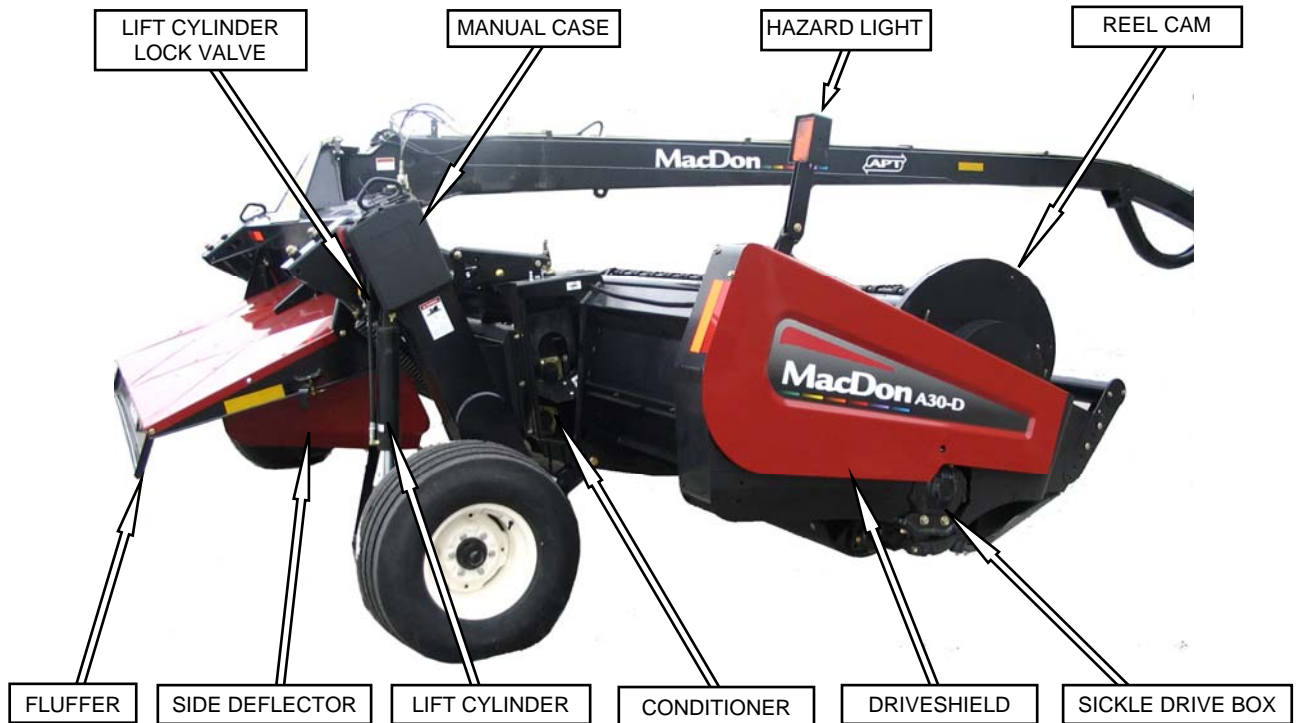
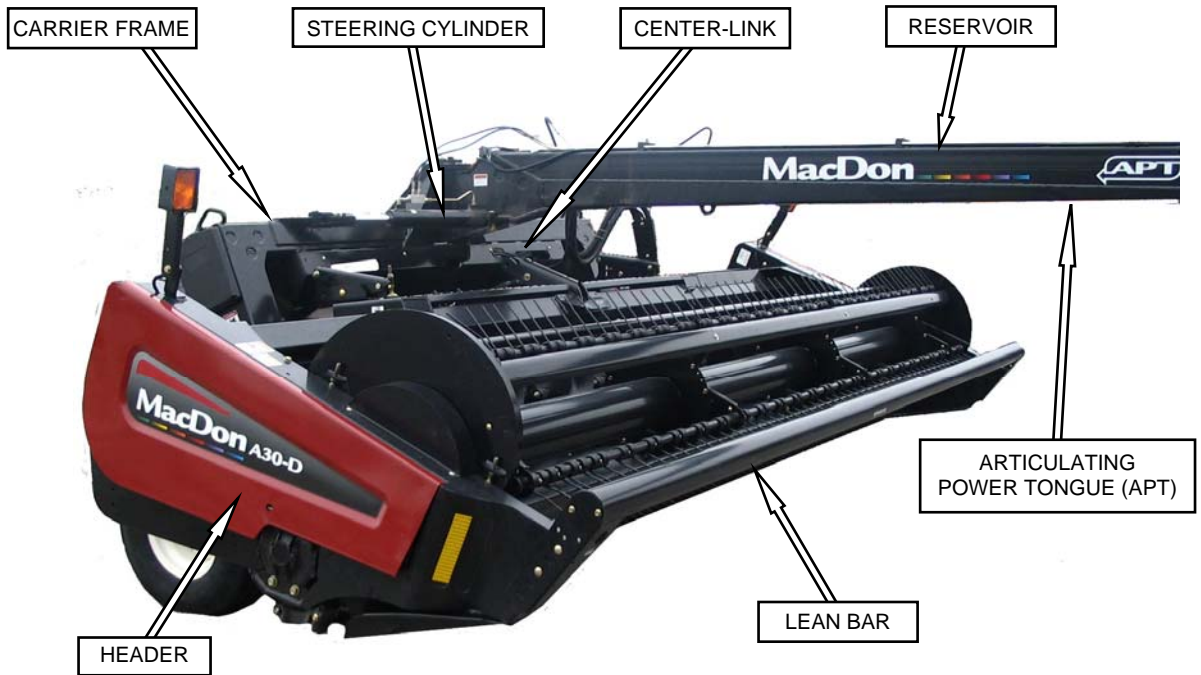

SECTION 4 COMPONENTS

PULL-TYPE (cont'd)

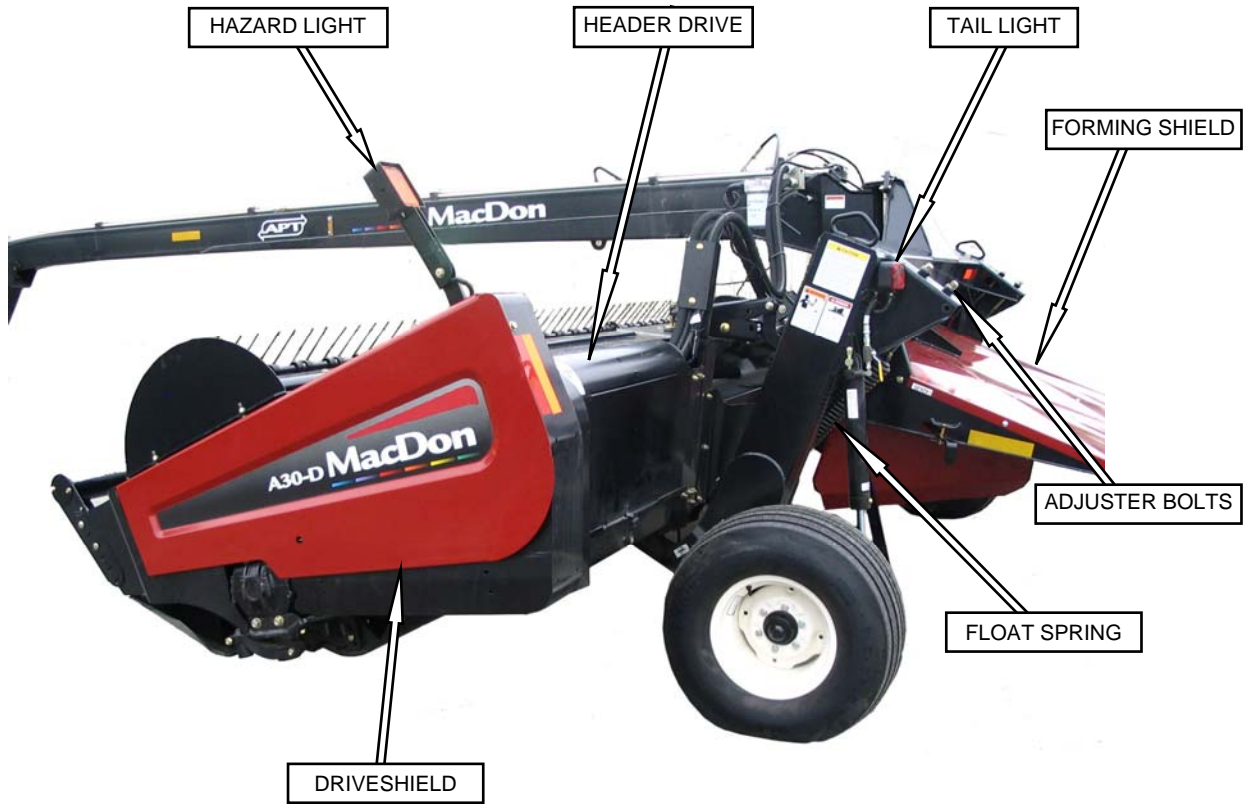

SECTION 4 COMPONENTS

PULL-TYPE (cont'd)

ARTICULATING POWER TONGUE

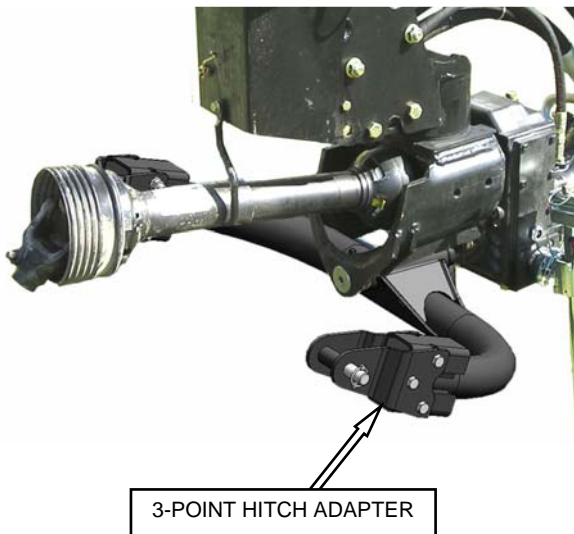

SECTION 4 COMPONENTS

4.2 SELF-PROPELLED

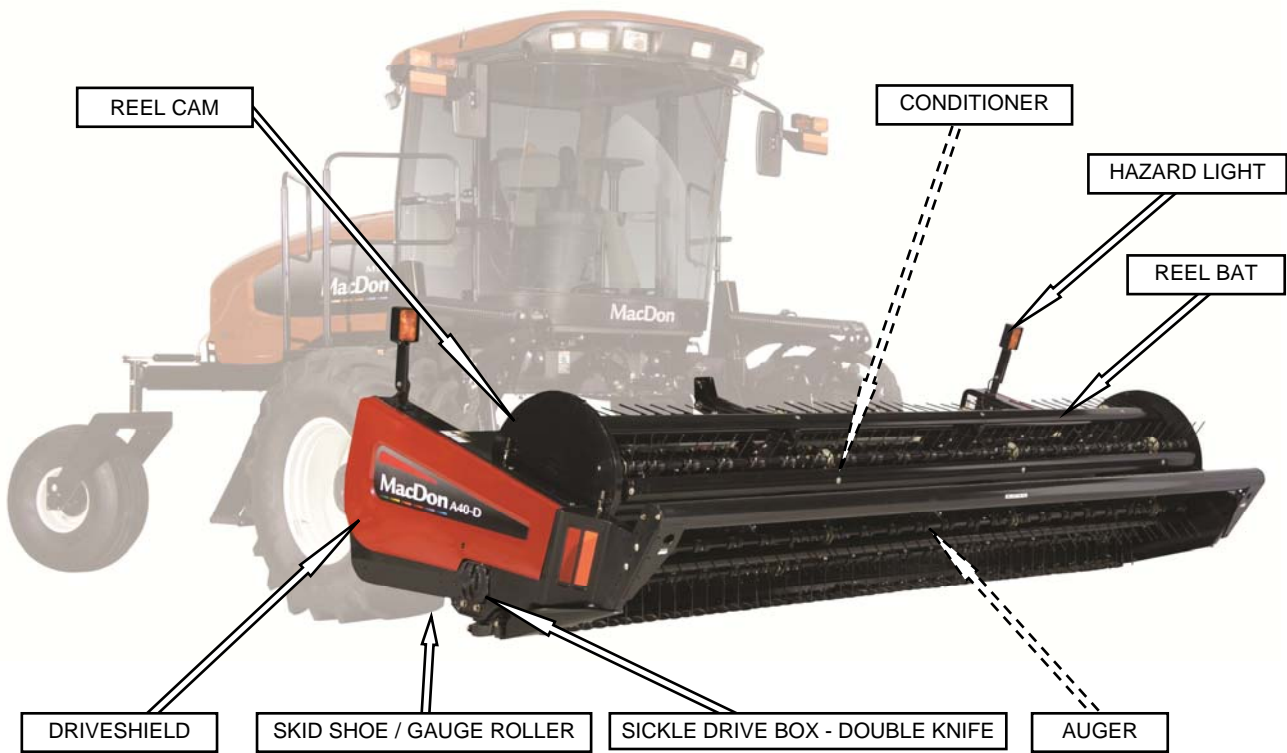
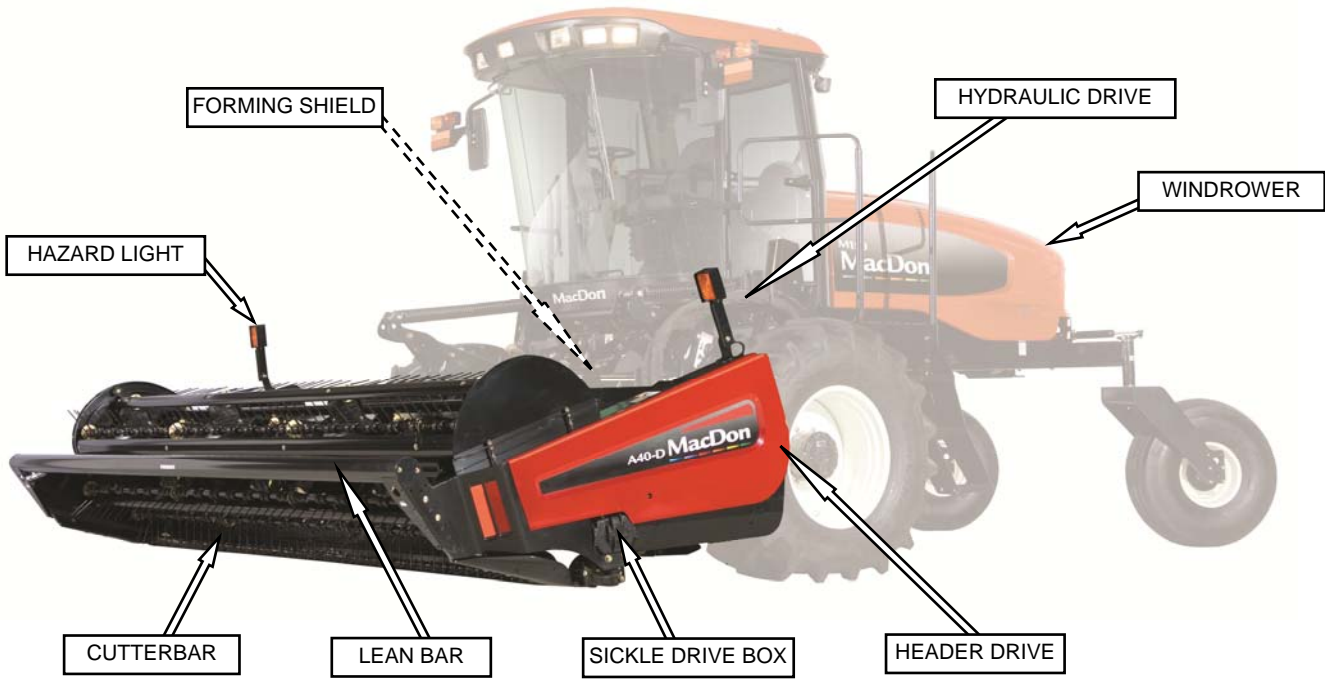

SECTION 5 SPECIFICATIONS

5 SPECIFICATIONS

5.1 PULL-TYPE HEADERS

HEADER SIZE		14 FT		16 FT		18 FT
HEADER MODEL		A30-S	A30-D	A30-S	A30-D	A30-D
FRAME and STRUCTURE						
Width		16 ft-3 in. (4953 mm)	n/a	17 ft-9 in. (5410 mm)		19 ft-3 in. (5867 mm)
Length	Transport	26 ft-7 in. (8130 mm)				
	Field	26 ft-7 in. (8130 mm)				
Height	Transport	86 in. (2184 mm)				
	Field	86 in. (2184 mm)				
Approximate Weight [lb (kg)]		7200 (3269)	n/a	7400 (3360)	8000 (3632)	8200 (3723)
Carrier		Pull-Type				
Lighting		Two Amber and Two Red Transport Lights				
Spare Knife Storage		Frame Tube	Lean Bar	Frame Tube	Lean Bar	
Reversing Wrench / Guard Straightening Tool		Stored Inside LH Endsheets				
Manual Storage		Frame Mounted Case				
WHEELS						
Tires		31 x 13.5 - 15 NHS 8 Ply Terra-Rib				
Tread Width		150 in. (3810 mm)				
Pressure		30 psi (207 kPa)				
CUTTERBAR						
Effective Cutting Width		14 ft-9 in. (4496 mm)		16 ft-3 in. (4953 mm)		17 ft-9 in. (5410 mm)
Cutting Height		4 in. (100 mm) Below Ground to 21 in. (533 mm) Above Ground				
Guard Angle Adjustment		8–16°				
MAIN DRIVE						
Tractor PTO Driven Gear Pump	1000 rpm PTO	2.01 cu. in. (33 cc) with 3:1 Ratio Gearbox				
HEADER DRIVE						
Hydraulic		M44 (44 cc) Motor To Gearbox				
SICKLE						
Drive Type	Type	Belt Driven Heavy Duty (MD) Sickle Drive Box (Enclosed Oil Bath)				
	Qty	One	Two	One	Two	
Sickle Speed (Strokes Per Minute)	No Load	1970	1980	1970	1980	
	Load	1510	1910			
Stroke		3 in. (76 mm)				
Sections		Bolted Over-Serrated, 9 Serrations/Inch.				
Guards		Forged and Double Heat-Treated				

SECTION 5 SPECIFICATIONS

PULL-TYPE HEADERS (cont'd)

HEADER SIZE			14 FT		16 FT		18 FT
HEADER MODEL			A30-S	A30-D	A30-S	A30-D	A30-D
AUGER							
Drive		Mechanical	2 Belts To Chain				
Size		Tube	10 in. (254 mm) O.D				
		Flighting	20 in. (508 mm) O.D., 0.25 in. (6 mm) thick.				
Type		Undershot, Center Feed. Rubber Finger Feed.					
Stripper Bars		3 Per Side					
Speed (rpm)	20T Sprocket	No Load	265	275	265	275	
		Load	256	265	256	265	
	19T Sprocket	No Load	252	261	252	261	
		Load	243	252	243	252	
Delivery Opening		95.7 in. (2430 mm)					
REEL							
Drive		Mechanical	2 Belts From Auger To Chain Final Drive				
Type		Bats	5-Bat (6-Bat Optional)				
		Tines	Steel: 0.25 in. (6 mm) Diameter				
Tine Bar Bearings		Replaceable Polyethylene					
Radius (to tine tip)		22 in. (540 mm)					
Speed (rpm)	20T Sprocket	20T Auger	No Load	71	74	71	74
			Load	69	71	69	71
		19T Auger	No Load	68	70	68	70
			Load	65	68	65	68
	19T Sprocket	20T Auger	No Load	68	70	68	70
			Load	65	68	65	68
		19T Auger	No Load	64	67	64	67
			Load	62	64	62	64
CONDITIONER							
Drive		Hydraulic	M44 (44cc) Motor To Enclosed Oil-Bath Gearbox				
Roll Type		Intermeshing Steel Bars					
Roll Diameter		Bars	9.17 in. (233 mm) O.D.				
		Tube	6.63 in. (168 mm) O.D.				
Roll Length		102 in. (2590 mm)					
Roll Speed (rpm)		No Load - 824 Load - 795					
Swath Width		36 in. (915 mm) to 92 in. (2340 mm)					
Unplugging Assist		Rolls Open As Header Lifts. Rolls Can Open to 4.25 in. (108 mm) During Operation					
Forming Shields		Header Mounted Adjustable Baffle and Side Deflector System For 36 in. (915 mm) to 100 in. (2540 mm) Swath Width					
OPERATING SPEED							
Recommended Cutting		5 mph (8 km/hr)					
Recommended Transport		20 mph (30 km/hr)					
TRACTOR REQUIREMENTS							
Power (minimum)		90 HP (68 kW)	110 HP (83 kW)	130HP (98 kW)			
Hydraulics		2000 psi (13,714 kPa)					

NOTES: 1. Specifications and design are subject to change without notice or obligation to revise previously sold units.

SECTION 5 SPECIFICATIONS

5.2 SELF-PROPELLED HEADERS

HEADER SIZE		14 FT		16 FT		18 FT	
HEADER MODEL		A30-S	A40-D	A30-S	A40-D	A40-D	
FRAME and STRUCTURE							
Width		16 ft-3 in. (4953 mm)		17 ft-9 in. (5410 mm)		19 ft-3 in. (5867 mm)	
Weight (lb [kg])		n/a	5680 (2579)	n/a	5850 (2656)	6020 (2733)	
Carrier		MacDon M Series Self-Propelled Windrowers					
Lighting		Two Amber Transport Lights					
Spare Knife Storage		Frame Tube	Lean Bar	Frame Tube	Lean Bar	Lean Bar	
Reversing Wrench/Guard Straightening Tool		Stored Inside LH Endsheets					
Manual Storage		Windrower Cab					
CUTTERBAR							
Effective Cutting Width		14 ft-9 in. (4496 mm)		16 ft-3 in. (4953 mm)		17 ft-9 in. (5410 mm)	
Cutting Height		5.9 in. (150 mm) Below Ground to 35.4 in. (900 mm) Above Ground					
Guard Angle Adjustment		7–17.5°					
HEADER DRIVE							
		A30	Hydraulic From Windrower Pump to One Piston Motor				
		A40	Hydraulic From Windrower Pump to One Piston Motor and Two Gear Motors				
SICKLE							
Belt Driven Heavy Duty (MD) Sickle Drive Box (Enclosed Oil Bath)		Belt Type	V	Timing	V	Timing	
		Quantity	One	Two	One	Two	Two
Sickle Speed (Strokes Per Minute)		1540	1450–1950	1540	1450–1950	1450–1950	
Stroke		3 in. (76 mm)					
Sections		Bolted Over-Serrated, 14 Serrations/Inch. (9 Serrations/Inch Optional)					
Guards		Forged And Double Heat-Treated					
AUGER							
Drive	Hydraulic Direct Mounted Motor		--	15.9 in ³ (261 cc) /rev	--	15.9 in ³ (261 cc) /rev	15.9 in ³ (261 cc) /rev
	Mechanical		2 Belts To Chain	---	2 Belts To Chain	---	---
Max Speed (rpm)		20T Sprocket	260	230–320*	260	230–320*	230–320*
		19T Sprocket Tube	250		250		
Size	19T Sprocket Tube		10 in. (254 mm) O.D.				
	Flighting		20 in. (508 mm) O.D., 0.25 in. (6 mm) thick.				
Type		Undershot, Center Feed. Rubber Finger Feed					
Stripper Bars		3 Per Side					
Delivery Opening		95.7 in. (2430 mm)					

* Maximum Speed on M100, M105 Windrower

SECTION 5 SPECIFICATIONS

SELF-PROPELLED HEADERS *(cont'd)*

HEADER SIZE		14 FT		16 FT		18 FT	
HEADER MODEL		A30-S	A40-D	A30-S	A40-D	A30-D	A40-D
REEL							
Drive	Hydraulic Direct Mounted Motor	---	14.2 in ³ (232 cc) /rev	---	14.2 in ³ (232 cc) /rev	---	14.2 in ³ (232 cc) /rev
	Mechanical From Auger	2 Belts/Chain Final Drive	---	2 Belts/Chain Final Drive	---	2 Belts/Chain Final Drive	---
Type		5-Bat (6-Bat Opt)	6-Bat (7 Opt)	5-Bat (6 Opt)	6-Bat (7 Opt)	5-Bat (6 Opt)	6-Bat (7 Opt)
Tines	Steel: 0.25 in. (6 mm) Dia.						
Tine Bar Bearings		Replaceable Polyethylene	Greasable Ball	Replaceable Polyethylene	Greasable Ball	Replaceable Polyethylene	Greasable Ball
Radius (to tine tip)	22 in. (540 mm)						
Maximum Speed (rpm)	22T Sprocket	22T Auger	77	15-85*	77	15-85*	73
		19T Auger	67		67		69
	19T Sprocket	22T Auger			58		58
		19T Auger					
CONDITIONER							
Drive	Hydraulic	M44 (44cc) Motor To Enclosed Oil-Bath Gearbox					
Roll Type	Intermeshing Steel Bars						
Roll Diameter	Bars	9.17 in. (233 mm) O.D.					
	Tube	6.63 in. (168 mm) O.D.					
Roll Length	102 in. (2590 mm)						
Roll Speed (rpm)	810	601-810	810	601-810	810	601-810	
Unplugging Assist	Reversing Flow To Hydraulic Motors						
Forming Shields	Windrower Mounted Side Deflector System For 36 in. (915 mm) to 100 in. (2540 mm) Swath Width						
OPERATING SPEED							
Recommended Cutting	5 mph (8 km/hr)						

* 50-85 rpm for M100, M105.

NOTE: 1. Specifications and design are subject to change without notice or obligation to revise previously sold units.

SECTION 6 OPERATION

6 OPERATION

6.1 OWNER/OPERATOR RESPONSIBILITIES



CAUTION

- It is your responsibility to read and understand this manual completely before operating the header/mower conditioner. Contact your Dealer if an instruction is not clear to you.
- Follow all safety messages in the manual and on safety signs on the machine.
- Remember that YOU are the key to safety. Good safety practices protect you and the people around you.
- Before allowing anyone to operate the header/mower conditioner, for however short a time or distance, make sure they have been instructed in its safe and proper use.
- Review the manual and all safety related items with all Operators annually.
- Be alert for other Operators not using recommended procedures or not following safety precautions. Correct these mistakes immediately, before an accident occurs.
- Do not modify the machine. Unauthorized modifications may impair the function and/or safety and affect machine life.
- Safety information given in this manual does not replace safety codes, insurance needs, or laws governing your area. Be sure your machine meets the standards set by these regulations.
- Ensure that tractor is properly equipped to safely operate mower conditioner. This may include adding ballast according to Tractor Operator's Manual requirements for attachments of this size and mass.

6.2 OPERATIONAL SAFETY



CAUTION

- Follow all safety and operational instructions given in your Operator's Manual. If you do not have a tractor/windrower manual, get one from your Dealer and read it thoroughly.

- Never attempt to start tractor/windrower engine or operate the machine, except from the Operator's seat.
- Check the operation of all controls in a safe clear area before starting work.
- Do not allow riders on tractor/windrower or mower conditioner.
- Never start or move the machine until you are sure all bystanders have cleared the area.
- Avoid travelling over loose fill, rocks, ditches or holes.
- Drive slowly through gates and doorways.
- If cutting ditch banks, use extreme caution. If the header/mower conditioner hits an obstruction, front of the tractor will usually swerve towards the ditch.
- When working on inclines, travel uphill or downhill when possible. Be sure to keep tractor transmission in gear when travelling downhill.
- Never attempt to get on or off a moving tractor/windrower.
- Do not get off the tractor/windrower while the machine is in operation.
- Stop tractor/windrower engine and remove key before adjusting or removing plugged material from the machine. A child or even a pet could engage the drive.
- Check for excessive vibration and unusual noises. If there is any indication of trouble, shut down and inspect machine. Follow proper shutdown procedure:
 - engage tractor/windrower brake.
 - disengage PTO.
 - turn engine OFF, and remove key.
 - wait for all movement to stop
 - dismount and engage cylinder stops before inspecting raised machine.
- Operate only in daylight or good artificial light.

SECTION 6 OPERATION

6.3 TRACTOR SETUP: PULL-TYPE

6.3.1 Tractor Requirements

HEADER WIDTH	MINIMUM POWER HP (KW)	MINIMUM DRAWBAR CAPACITY LBF (N)	MINIMUM HYDRAULICS psi (MPA)
14 FT	90 (68)	1400 (6227)	2000 (13.7)
16 FT	110 (83)	1450 (6449)	
18 FT	130 (98)	1500 (6672)	

NOTE

Tractor must be equipped with a seven terminal outlet to supply power to the mower conditioner's warning lights.

6.3.2 Drawbar Adjustment



CAUTION

Shut off tractor, engage parking brake, and remove key before working around hitch.

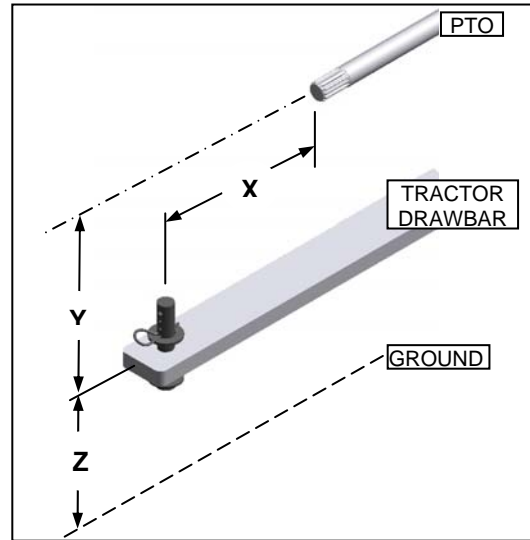

Adjust tractor drawbar to meet ASAE Standard specifications as listed below:

DIMENSION	1000 RPM PTO	
	1.37 IN. DIA.	1.75 IN. DIA.
X	16 in. (406 mm)	20 in. (508 mm)
Y	6–12 in. (152–305 mm) 8 in. (203 mm) Recommended	
Z	13–17 in. (330–432 mm) 16 in. (406 mm) Recommended	

IMPORTANT

Improper drawbar length can cause vibration and premature pump gearbox failure.

SECTION 6 OPERATION

6.3.3 Drawbar Hitch Set-Up

- a. Secure tractor drawbar so the hitch-pin hole is directly below the driveline.

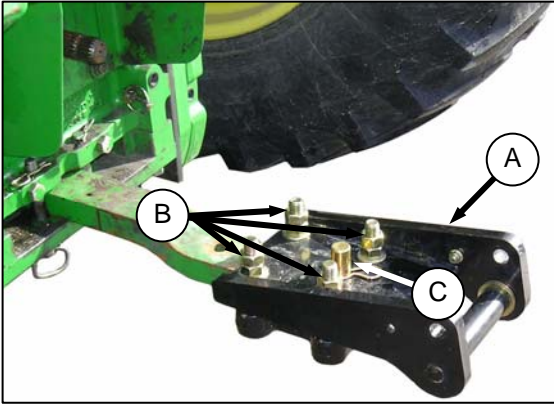

- b. Loosen bolts (B) on extension assembly (A), and slide onto drawbar.
- c. Install pin (C) through drawbar and extension from underside, and secure with hairpin.
- d. Gradually tighten four bolts to 265 ft-lbf (359 N·m).

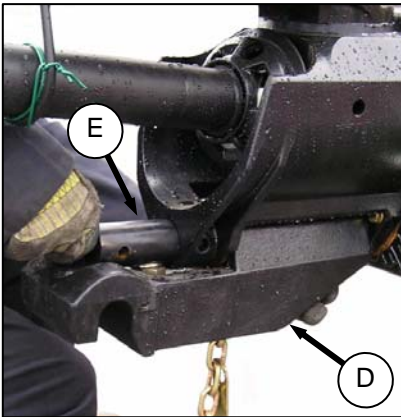

- e. Attach the swivel APT member (D) with pin (E) onto the APT.

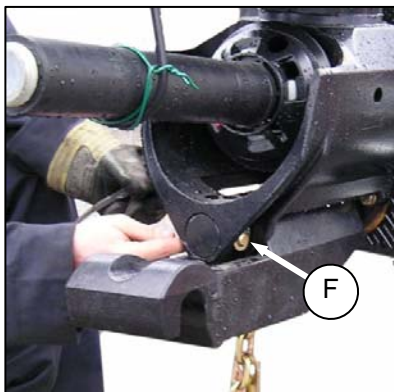

- f. Secure pin with clevis pin (F), washers, and cotter pin.

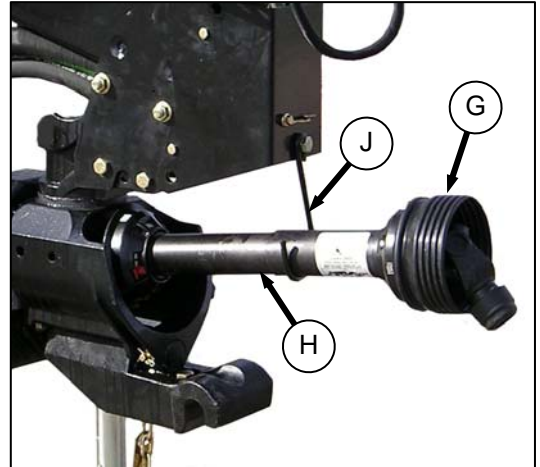

- g. Assemble PTO driveline male half (G) onto PTO shaft (H) on APT. Push male half so that PTO shaft is at its fully compressed length.
- h. Locate PTO shaft in hook (J).

SECTION 6 OPERATION

6.3.4 3 Point Hitch (Cat. II, III or IIIN) Set-Up

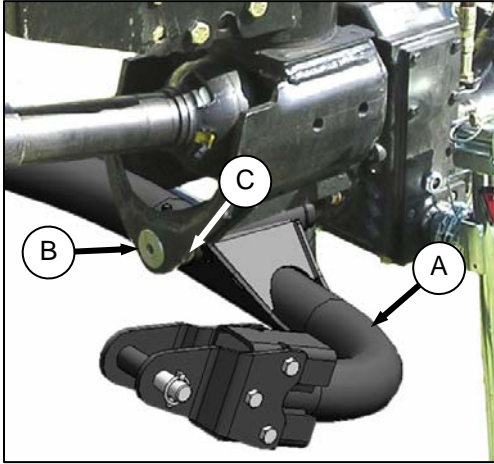

- Attach the 3 point hitch adapter (A) to the APT with pin (B). The installation is similar to that described in the previous section.
- Secure pin (B) with clevis pin (C), washers, and cotter pin.
- The arms on the adapter (A) can be set up to suit Category II and IIIN, or Category III tractor hitch arms:

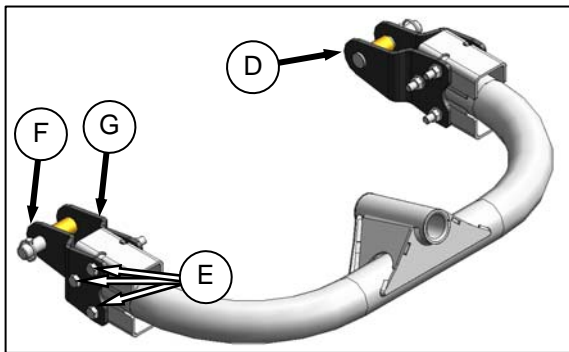

CATEGORY II or IIIN

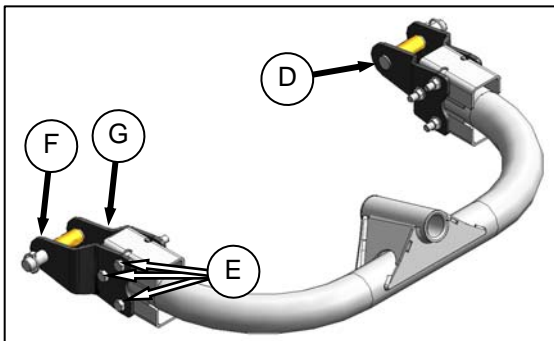

CATEGORY III

- Remove pins (D).
- Remove bolts (E) (3 per side).

- Flip outer plate (F) and inner plate (G) on each arm.

IMPORTANT

The inner plate (G) has a smaller joggle than the outer plate (F). Always maintain the proper locations.

- Re-install bolts (E).
- Replace pins (D).

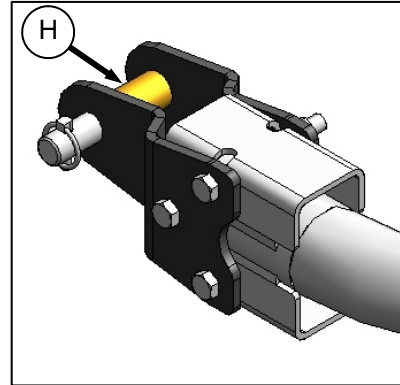

NOTE

Bushings (H) on pins can be removed to suit hole size in tractor hitch arms.

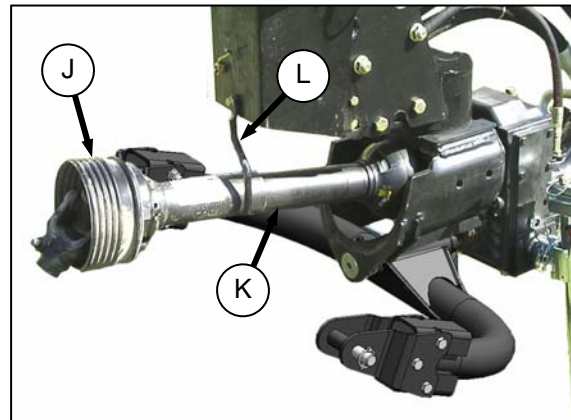

- Assemble PTO driveline male half (J) onto PTO shaft (K) on APT. Push male half so that PTO shaft is at its fully compressed length.
- Locate PTO shaft in hook (L).

SECTION 6 OPERATION

6.4 MOWER CONDITIONER / TRACTOR HOOKUP: PULL-TYPE



CAUTION

Shut off tractor, engage parking brake, and remove key before working around hitch.



CAUTION

Never attach mower conditioner to tractor rear axle or three-point hitch arms.

6.4.1 Drawbar Hook-Up

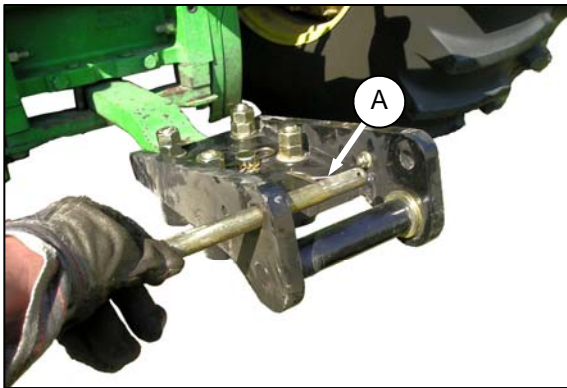

- a. Remove pin (A).

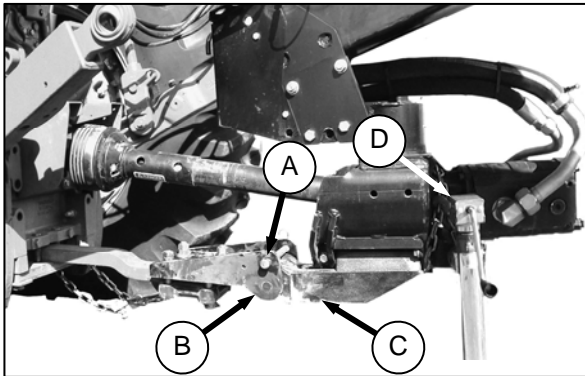

- b. Position tractor to align drawbar extension (B) with arm (C) on mower conditioner.
c. Lower jack (D) to engage arm (C) on drawbar extension (B).
d. Install hitch-pin (A), and secure with hairpin.

IMPORTANT

If the tractor has a three-point hitch, lower the lower links as low as possible to prevent damage to the APT.

- e. Attach driveline (E) to tractor PTO shaft as follows:

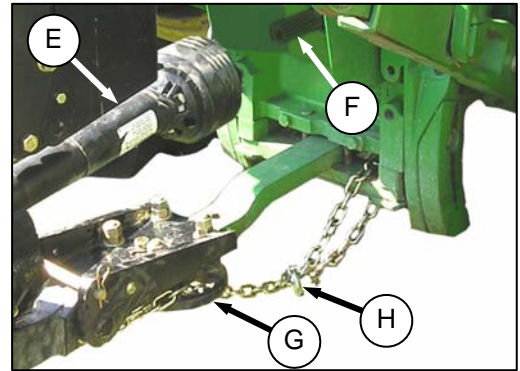

1. Position driveline onto tractor PTO shaft (F).
 2. Pull back collar on driveshaft, and push driveshaft until it locks. Release collar.
- f. Route safety chain from mower conditioner through chain support (G), around drawbar support, and lock the hook (H) on chain.

IMPORTANT

Adjust chain length to remove all slack except what is needed for turns.

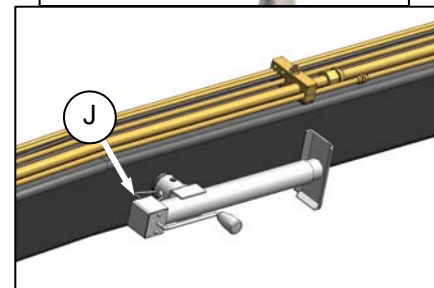
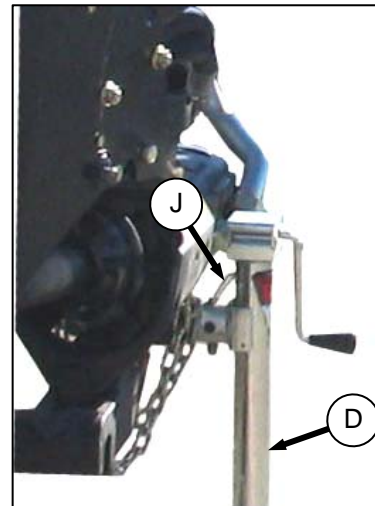

- g. Raise jack (D), pull pin (J) and move jack to storage position on side of APT.
h. Secure jack with pin (J).
i. Proceed to Section 6.4.3 *Hydraulic Connections*.

SECTION 6 OPERATION

6.4.2 3 Point Hitch (Cat. II, III, or IIIN) Hook-Up



CAUTION

Shut off tractor, engage parking brake, and remove key before working around hitch.

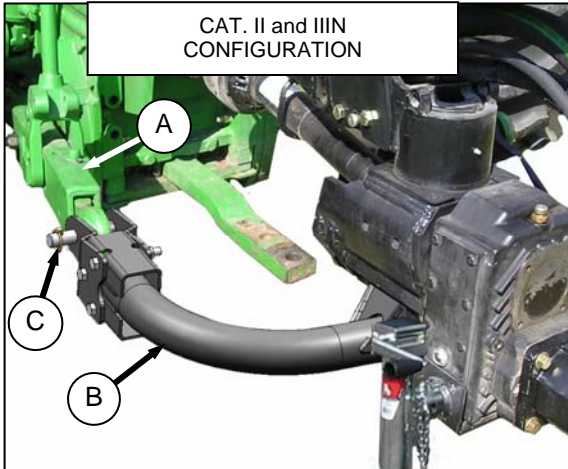

- Position tractor, and align tractor hitch arms (A) with hitch adapter (B). Shut off tractor, and remove key.
- Remove pins (C) from hitch adapter, and use the jack to adjust height of APT so that pins (C) can be re-installed.

NOTE

If tractor is equipped with a quick hitch system, pins (C) do not need to be removed.

- Secure pins (C) with lynch pins.
- Install anti-sway bars on tractor hitch to stabilize lateral movement of hitch arms (A). Refer to your tractor Operator's Manual.

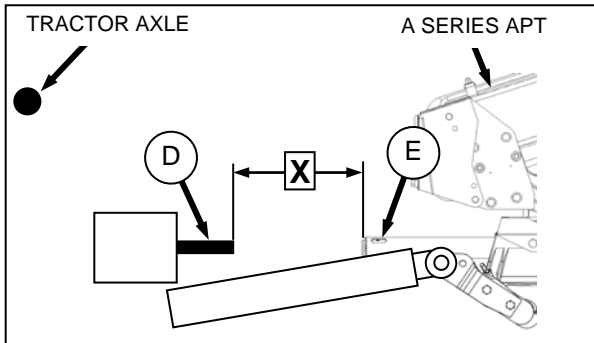

- Check distance 'X' between tractor PTO shaft (D) and implement input shaft (E) (without the front half of the driveline attached).

- The measurement must not exceed the dimensions listed below.

DRIVELINE SHAFT SIZE	DISTANCE 'X'
1.375 in. (34 mm)	27 in. (685 mm)
1.75 in. (43 mm)	31 in. (790 mm)

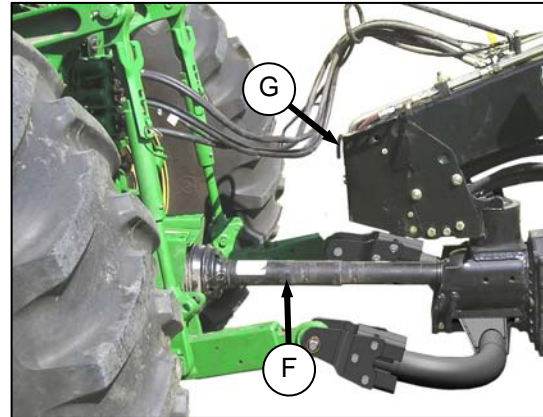

- Position driveshaft (F) onto tractor PTO shaft. Driveline should be approximately level.

IMPORTANT

Front half of driveline (F) for 3-point hitch is longer than the driveline for draw-bar hitch. Ensure proper length driveline is used.

- Pull back collar on driveshaft, and push driveshaft until it locks. Release collar.
- Rotate driveline storage hook (G) to upward position.

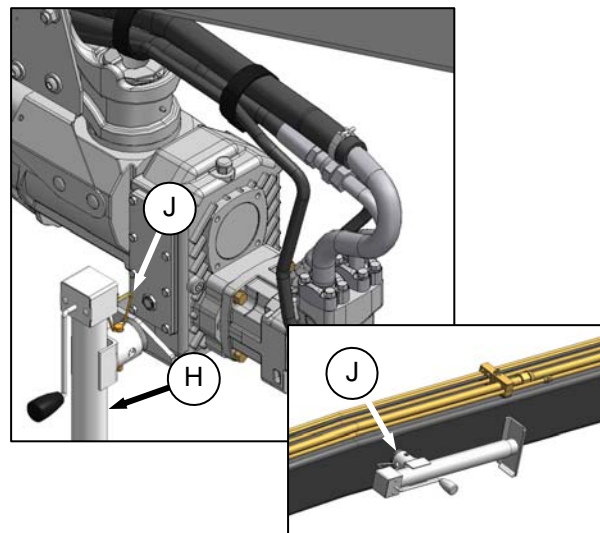

- Raise jack (H), pull pin (J), and move jack to storage position on side of APT. Secure jack with pin (J).

SECTION 6 OPERATION

6.4.3 Hydraulic Connections



WARNING

Do not use remote hydraulic system pressures over 3000 psi (20684 kPa). Check your tractor Operator's Manual for remote system pressure.

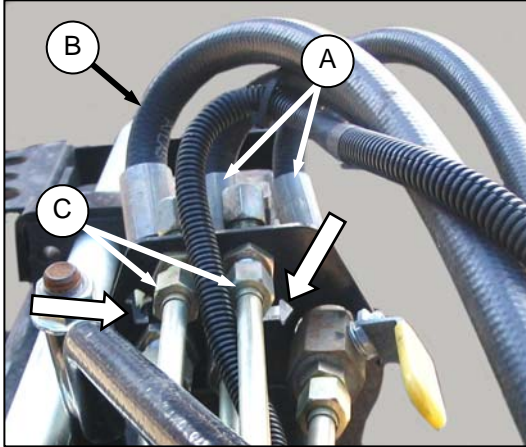

SYSTEM	HOSE	TRACTOR HYDRAULICS
Steering	A (2 Hoses)	Control 1
Lift	B (1 Hose)	Control 2
Header Tilt	C (2 Hoses)	Control 3

NOTE

Arrows cut into plate indicate system for hoses. LIFT ↑ STEERING ↔

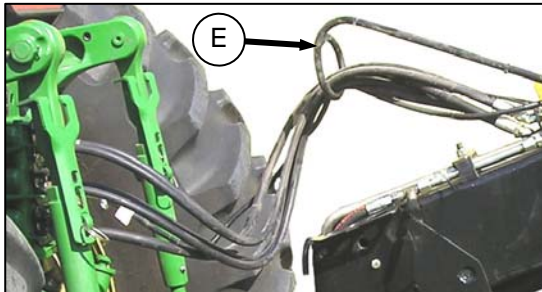

- a. Ensure hoses are routed through guide (E) to provide proper hose arc as shown.

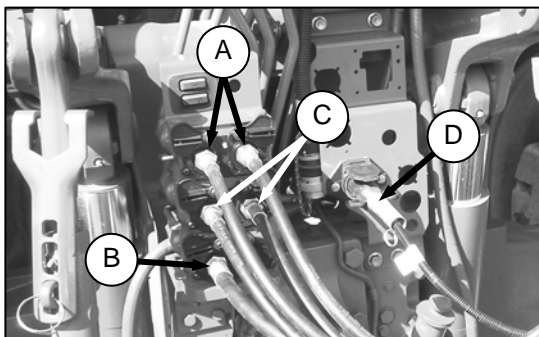

- b. Connect two **steering** cylinder hoses (A) as follows:

CONTROL LEVER POSITION	CYLINDER MOVEMENT	MOWER-CONDITIONER DIRECTION
Forward	Extend	Right
Backward	Retract	Left

- c. Connect one **lift** cylinder hose (B) as follows:

CONTROL LEVER POSITION	CYLINDER MOVEMENT	HEADER MOVEMENT
Forward	Retract	Lower
Backward	Extend	Raise

- d. Connect two **header tilt** cylinder hoses (C) as follows: (Not required with mechanical center-link).

CONTROL LEVER POSITION	CYLINDER MOVEMENT	HEADER MOVEMENT
Forward	Retract	Lower
Backward	Extend	Raise

- e. Connect the mower-conditioner wiring harness connector (D) to tractor. Connector is designed to fit tractors equipped with a round 7-pin receptacle (SAE J560).

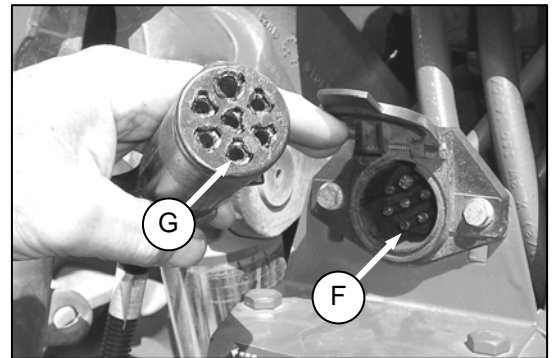

IMPORTANT

Older model tractors will have Pin #4 (F) energized as an accessory circuit. The mower conditioner uses this pin position (G) for brake lights. Check that Pin #4 in the tractor receptacle is not constantly energized - see your Tractor Operator's Manual, and if required, remove the appropriate fuse.

SECTION 6 OPERATION

6.5 MOWER CONDITIONER / TRACTOR UNHOOK: PULL-TYPE



CAUTION

To prevent accidental movement of tractor, shut off engine, engage parking brake, and remove key.

To maintain stability, always lower the machine completely. Block mower conditioner wheels before detaching from tractor.

6.5.1 Drawbar Hitch Unhook

- Park machine on flat level surface with hitch at an angle to tractor drawbar (to facilitate pump detachment).
- Lower header onto blocks or leave header raised. If leaving in raised position, engage lift cylinder lock-out valves.
- Move remote cylinder control valve lever back and forth to relieve stored hydraulic pressure.

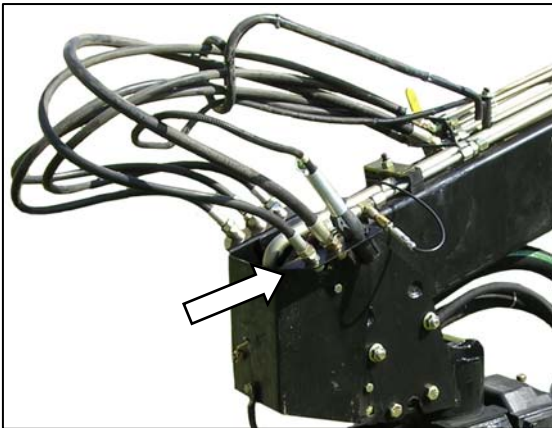

- Disconnect hydraulic hoses and electrical harness. Store hose ends in holes at front of APT as shown.

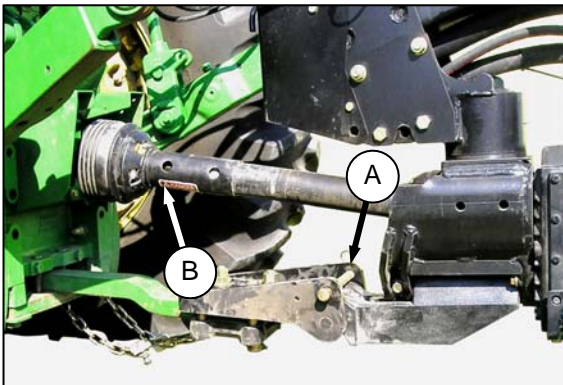

- Remove pin (A).

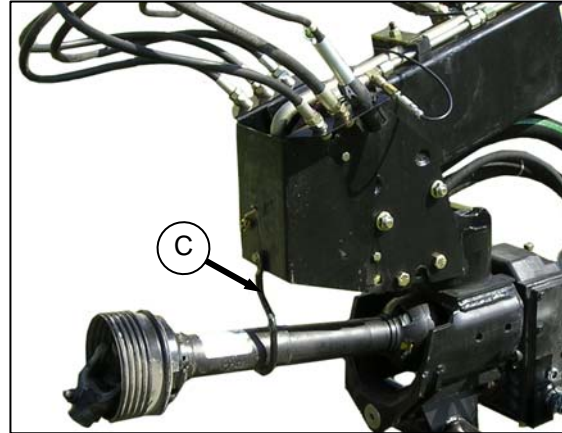

- Rotate hook (C) to the lower position.
- Pull back collar on driveline (B), slide coupler off tractor PTO shaft, and position driveline in hook.

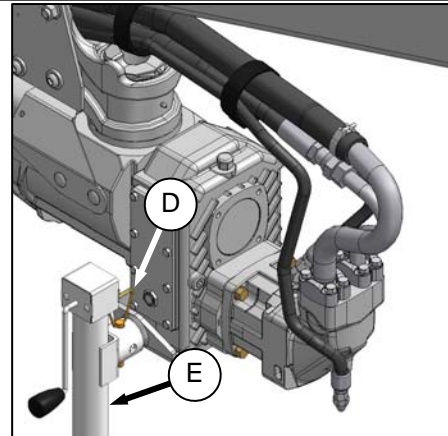
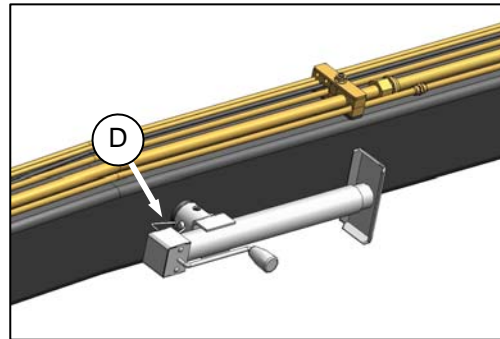

- Pull pin (D) securing jack (E), and move to working position at front of APT. Secure jack with pin (D).
- Lower jack to take weight off tractor drawbar.

NOTE

If ground is soft, place a block under the jack.

(continued next page)

SECTION 6 OPERATION

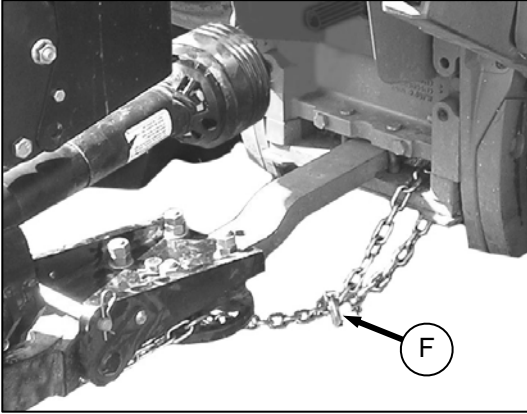

- j. Remove chain lock (F), and unhook safety chain from tractor. Wrap chain around APT for storage.
- k. Lower jack to raise APT clear of drawbar.
- l. Slowly drive tractor away from mower conditioner.

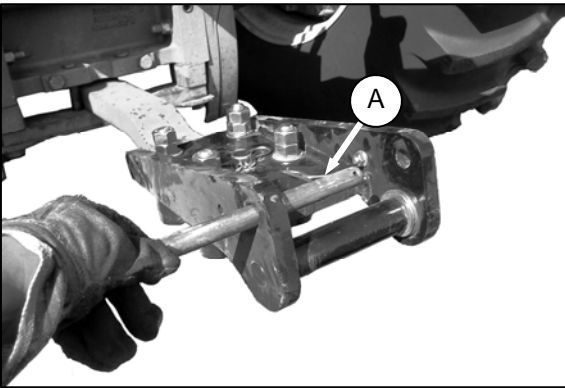

- m. Replace hitch pin (A), and secure with hairpin.

SECTION 6 OPERATION

6.5.2 3-Point Hitch Unhook

- Park machine on flat level surface.
- Lower header onto blocks, or leave header raised. If leaving in raised position, engage lift cylinder lock-out valves.



CAUTION

To prevent accidental movement of tractor, shut off engine, engage parking brake, and remove key.

To maintain stability, always lower the machine completely. Block mower conditioner wheels before detaching from tractor.

- Shut off engine, and remove key.
- Move remote cylinder control valve lever back and forth to relieve stored hydraulic pressure.

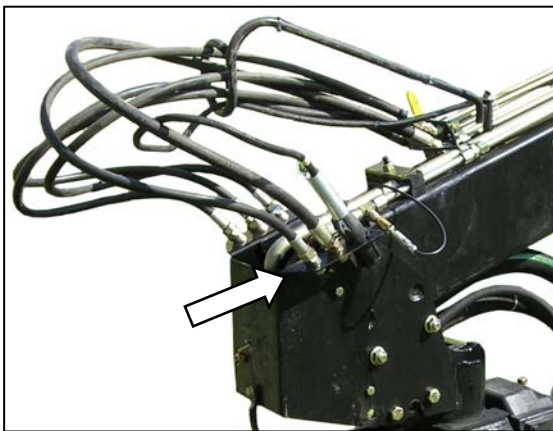

- Disconnect hydraulic hoses and electrical harness. Store hose ends in holes at front of APT as shown.

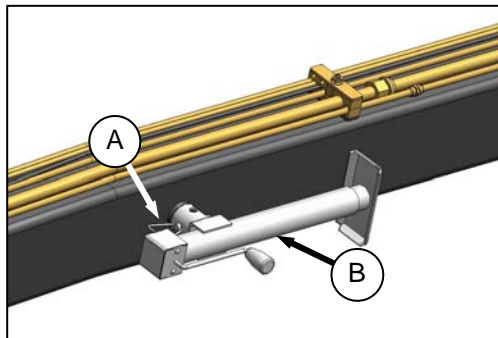

- Pull pin (A) securing jack (B) at storage location, and remove jack.

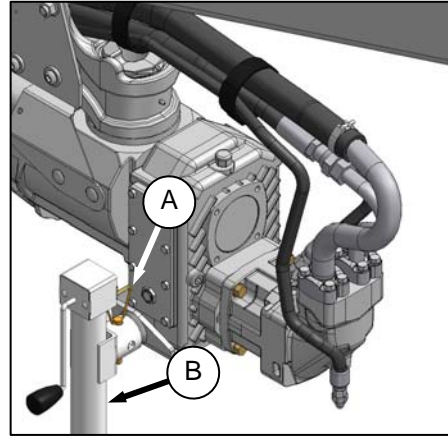

- Install at working position at front of APT. Secure jack with pin (A).

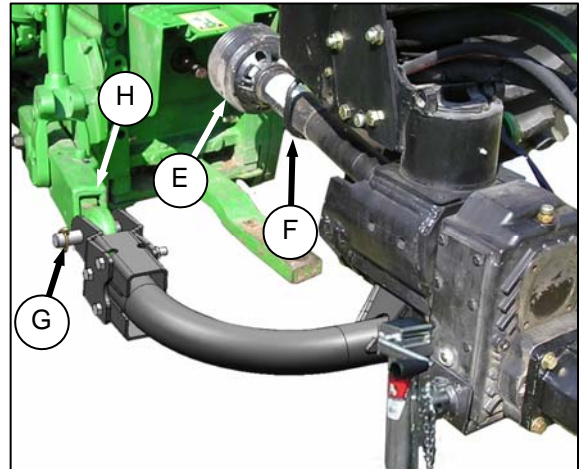

- Pull back collar on driveline (E), and slide coupler off tractor PTO shaft.
- Rotate hook (F) to lower position, and place driveline in hook.
- Lower jack to raise APT, and take weight off hitch arms.

NOTE

If tractor is equipped with a quick hitch system, pins (G) do not need to be removed.

- Remove lynch pins (G), and swing hitch arms (H) clear of APT.
- Slowly drive tractor away from mower conditioner.

SECTION 6 OPERATION

6.6 HEADER ATTACHMENT: SELF-PROPELLED

Refer to your Self-Propelled Windrower Operator's Manual for procedures for mechanically attaching the auger header to the self-propelled windrower, and for modifications if required to the windrower hydraulic connections.

Refer to the following procedures for electrical and hydraulic connections. Header drive hydraulic hoses and electrical harness are located on the LH cab-forward side of the windrower.

6.6.1 A30-S

6.6.1.1 M100, M105, M150, M200 M155

The M100, M105, M150, and M155 Windrowers are factory-equipped with A30-S header hydraulics and electrical harness. Proceed as follows:



DANGER

Stop engine, and remove key from ignition before leaving Operator's seat for any reason. A child or even a pet could engage an idling machine.

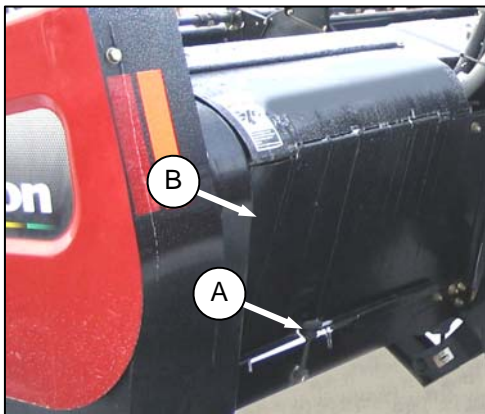

- Disengage rubber latch (A), and open driveline shield (B).

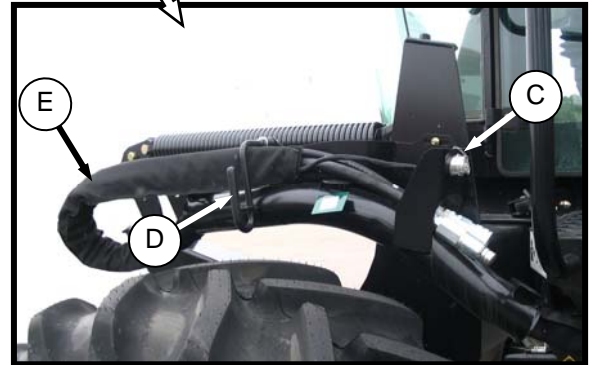

- Remove the cap (C) from electrical connector, and remove connector from support bracket.

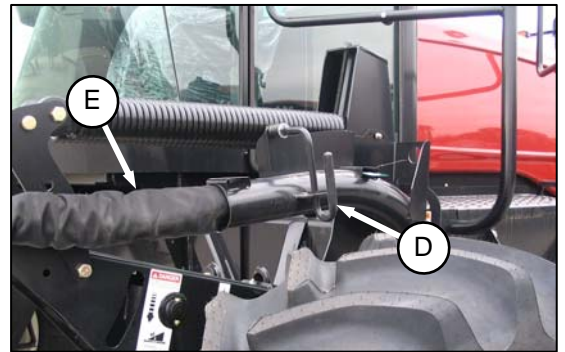

- Disengage and rotate lever (D) counterclockwise to fully up position to release the hose bundle (E).
- Move hose bundle (E) to header.
- Rotate lever (D) clockwise, and engage in bracket to store.

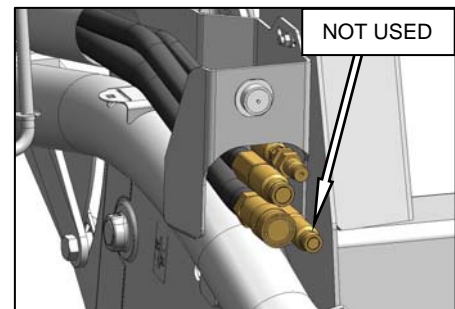

IMPORTANT

If the hose bundle contains four hoses (draper header operation), only three are required to power the A30-S header. Ensure loose hose is properly secured to avoid contact with the drivelines.

(continued next page)

SECTION 6 OPERATION

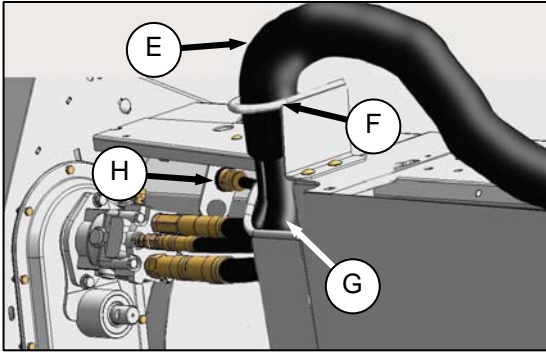

- f. Route hoses (E) from windrower through support (F) and access hole (G) in header frame.
- g. Remove cover on header electrical receptacle (H).
- h. Push connector onto receptacle, and turn collar on connector to lock it in place. Try to rotate collar to ensure it is locked.
- i. Attach cover to mating cover on windrower wiring harness.
- j. Remove caps (if installed) from hydraulic couplers, and clean if necessary.

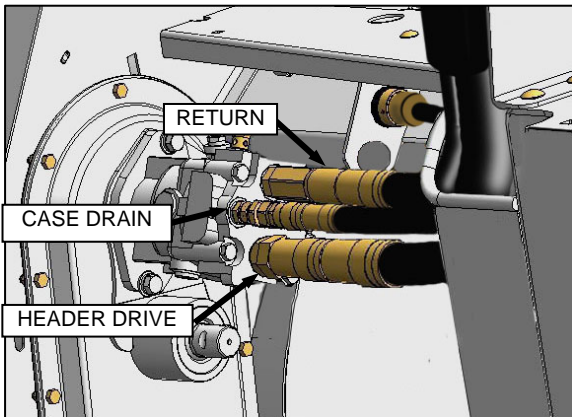

- k. Push hose connectors onto mating receptacles (as shown) until collars on receptacles snap into lock position.
- l. Close driveline shield before engaging header.
- m. Check to ensure that hoses and electrical harness clear tire.
- n. Proceed to Section 6.6.3 *Configure Reverser Valve Jumper Hose*.

6.6.1.2 M205

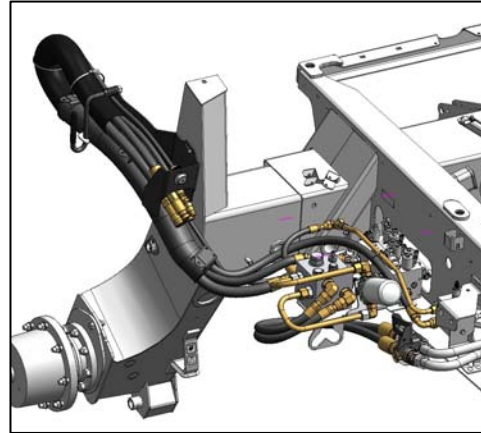

The M205 must be equipped with an auger drive basic kit, and a completion kit as shown above. If it is equipped, connect the hoses to the header in accordance with the procedure in the previous Section 6.6.1.1 M100, M105, M150, M155.

If necessary, obtain the following kits from your MacDon Dealer, and install them in accordance with the instructions supplied with the kit.

KIT DESCRIPTION	KIT NUMBER
Base Kit	B5491
Completion	B5492
Coupler	B5497

SECTION 6 OPERATION

6.6.2 A40-D



CAUTION

To prevent accidental movement of windrower, place all controls in NEUTRAL or in PARK, engage park brake (if applicable), shut off engine, and remove key.

IMPORTANT

For windrowers with Reverser Kit #B4656 to prevent draper header reel damage and improper operation: If switching between A40 Auger Header and Draper header, hose plumbing to reverser valve must be changed to suit the header type. See Instruction MD Part #169213 for proper plumbing for each header type.

6.6.2.1 M100, M105

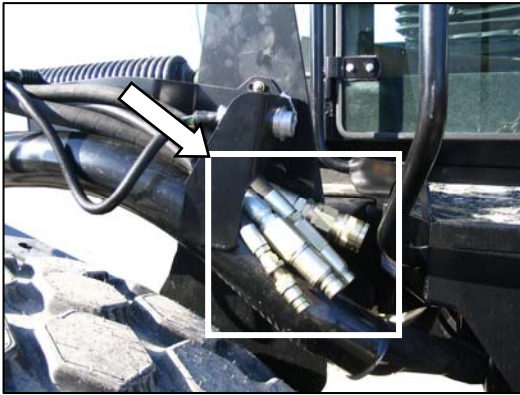

The M100 and M105 are factory-equipped with four hoses.

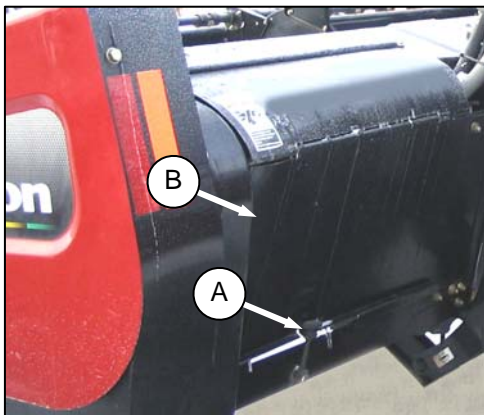

- a. Disengage rubber latch (A), and open driveline shield (B).

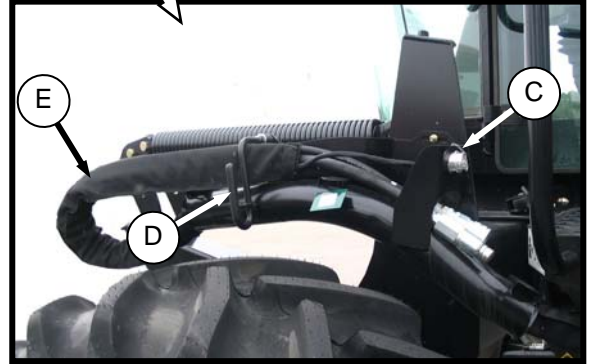

- b. Remove the cap (C) from electrical connector, and remove connector from support bracket.
- c. Disengage and rotate lever (D) counterclockwise to fully up position to release the hose bundle (E).

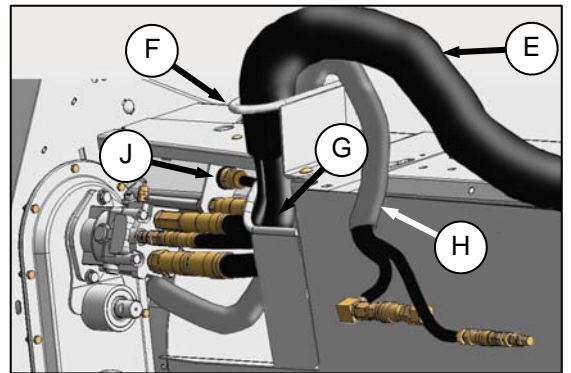

- d. Move hose/electrical bundle (E) to header.
- e. Route bundle (E) from windrower through support (F) and access hole (G) in header frame alongside existing hose bundle (H) from header.
- f. Remove cover on header electrical receptacle (J).
- g. Push connector onto receptacle, and turn collar on connector to lock it in place.
- h. Attach cover to mating cover on windrower wiring harness.
- i. Remove caps from hydraulic couplers, and clean if necessary.

(continued next page)

SECTION 6 OPERATION

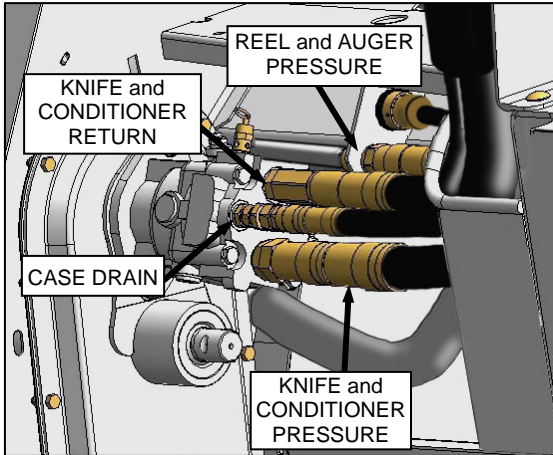

STANDARD HEADER

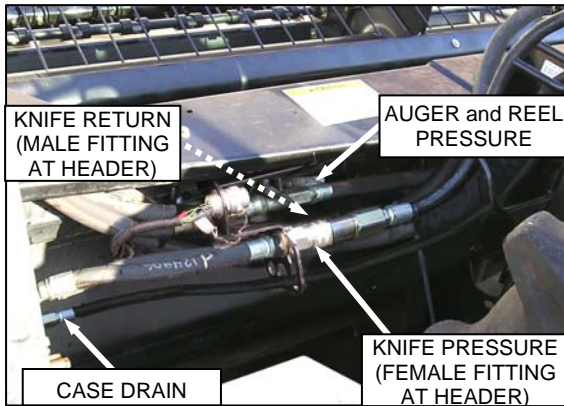
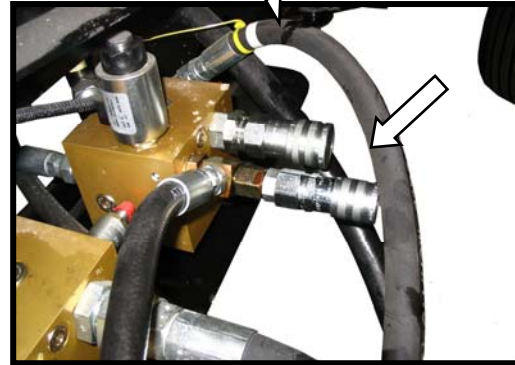

GRASS SEED HEADER

- j. Push hose connectors onto mating receptacles (as shown) until collars on receptacles snap into lock position.

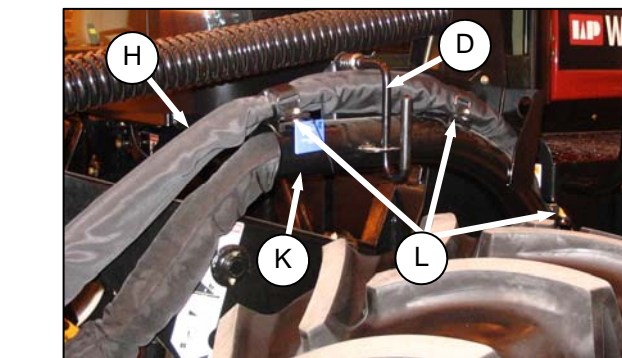
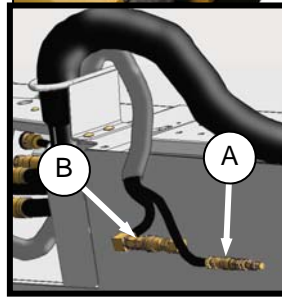
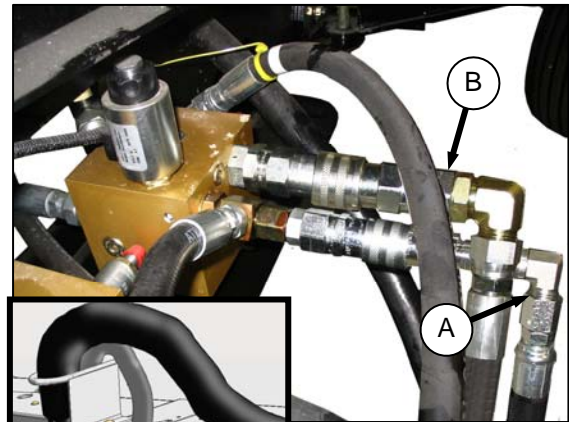

- k. Route auger return and reel pressure hose bundle (H) from header to windrower, and locate bundle above existing hose support (K) (as shown).
- l. Secure with three straps (L), and lower lever (D).

- m. If valve blocks are not configured (as shown), install required fittings as described in A30-S and A40-D Auger Self-Propelled Windrower Header Unloading and Assembly Instructions – MD Part #169078 that was supplied with your A40-D header.

- n. Push auger/reel pressure (A) and auger/reel return (B) hose couplers onto mating receptacles on valve block, until collar on receptacle snaps into lock position.

(continued next page)

SECTION 6 OPERATION

- o. Open header LH driveshield.
- p. Check hose routing at the reel motor. The hose routing depends on which windrower model the header is being attached to. The header is factory-configured for M150, M155, and M200 windrowers.

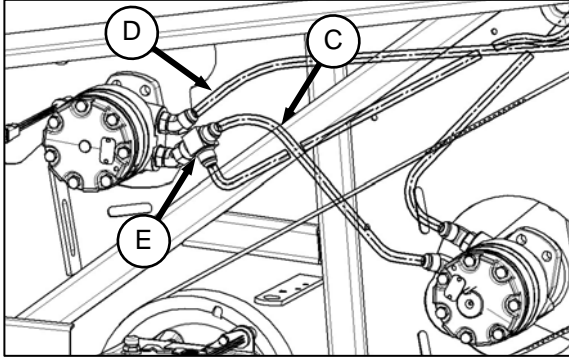

FACTORY CONFIGURATION
M150, M155 AND M200

- q. Change hoses as follows if header is being mounted on a M100, M105, or M205 windrower:

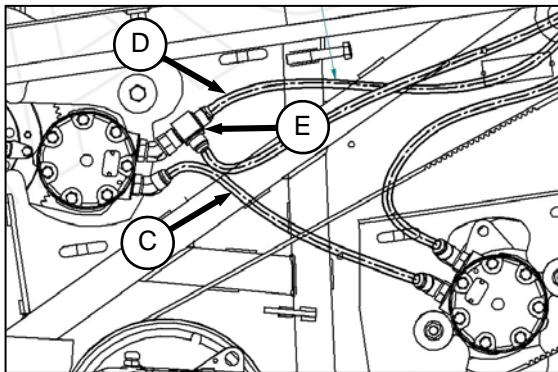

M100, M105, M205 CONFIGURATION

1. Disconnect hose (C) at tee (E).
2. Disconnect hose (D) at reel motor.
3. Disconnect tee (E) at motor lower port and relocate to upper port.
4. Connect hose (D) to tee (E).
5. Connect hose (C) to motor lower port.

SECTION 6 OPERATION

6.6.2.2 M150, M155



CAUTION

To prevent accidental movement of windrower, place all controls in **NEUTRAL** or in **PARK**, engage park brake (if applicable), shut off engine, and remove key.



The M150 is factory-equipped with four hoses.

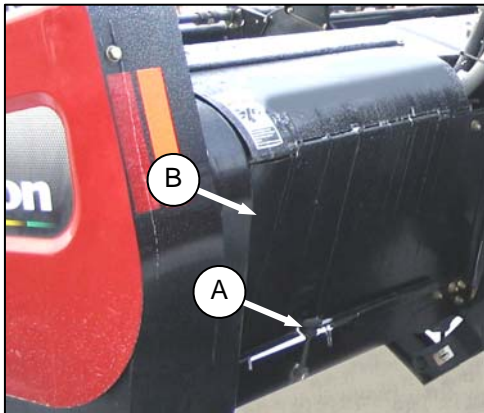

- a. Disengage rubber latch (A), and open driveline shield (B).

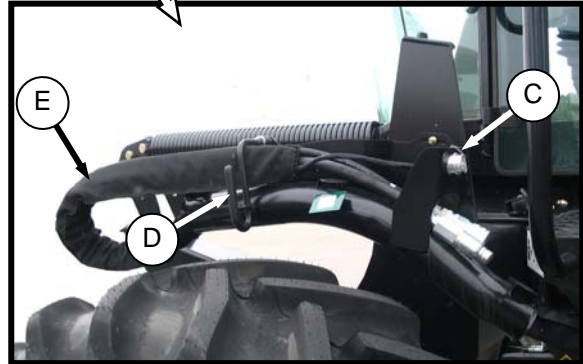

- b. Remove the cap (C) from electrical connector, and remove connector from support bracket.
c. Disengage and rotate lever (D) counterclockwise to fully up position to release the hose bundle (E).

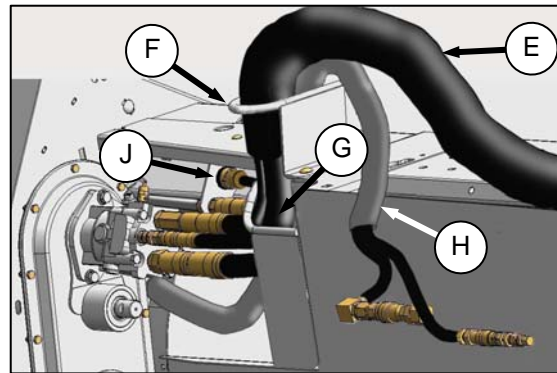

- d. Move hose/electrical bundle (E) to header.
e. Route bundle (E) from windrower through support (F) and access hole (G) in header frame alongside existing hose bundle (H) from header.
f. Remove cover on header electrical receptacle (J).
g. Push connector onto receptacle, and turn collar on connector to lock it in place.
h. Attach cover to mating cover on windrower wiring harness.
i. Remove caps from hydraulic couplers, and clean if necessary.

(continued next page)

SECTION 6 OPERATION

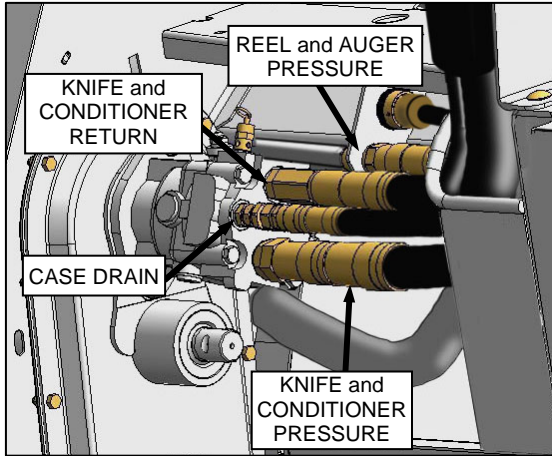

STANDARD HEADER

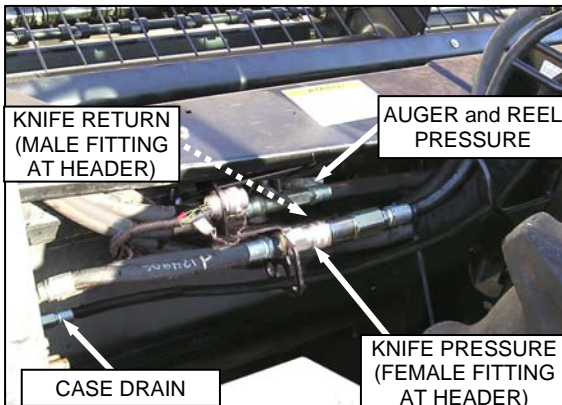

GRASS SEED HEADER

- j. Push hose connectors onto mating receptacles (as shown) until collars on receptacles snap into lock position.

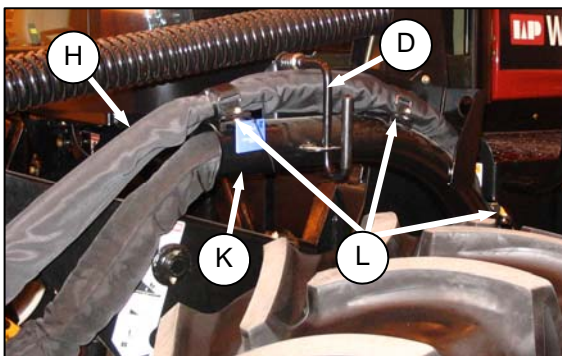

- k. Route auger return and reel pressure hose bundle (H) from header to windrower, and locate bundle above existing hose support (K) (as shown).
- l. Secure with three straps (L), and lower lever (D).

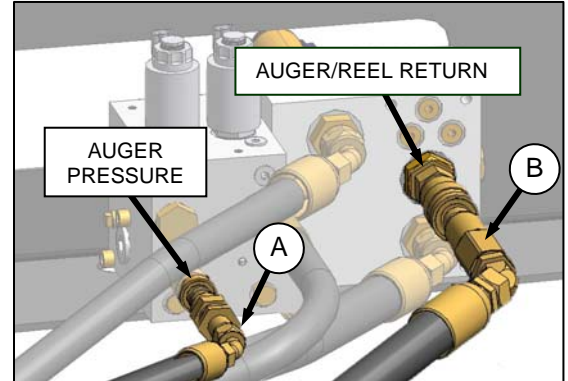
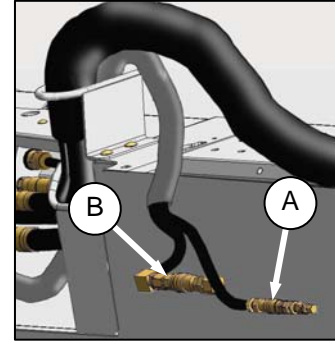

M150 - WITHOUT REVERSER VALVE

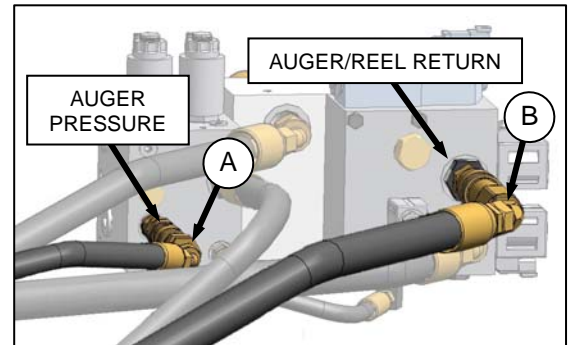

M150 - WITH REVERSER VALVE

- m. If valve blocks are not configured as shown above, install required fittings as described in A30-S and A40-D Auger Self-Propelled Windrower Header Unloading and Assembly Instructions - MD Part #169078 that was supplied with your A40-D header.
- n. Push auger pressure (A) and auger/reel return (B) hose couplers onto mating receptacles on valve block until collar on receptacle snaps into lock position.
- o. Proceed to Section 6.6.3 *Configure Reverser Valve Jumper Hose*.

SECTION 6 OPERATION

6.6.2.3 M200



CAUTION

To prevent accidental movement of windrower, place all controls in **NEUTRAL** or in **PARK**, engage park brake (if applicable), shut off engine, and remove key.



The Windrower requires four hoses to run an A40-D header.

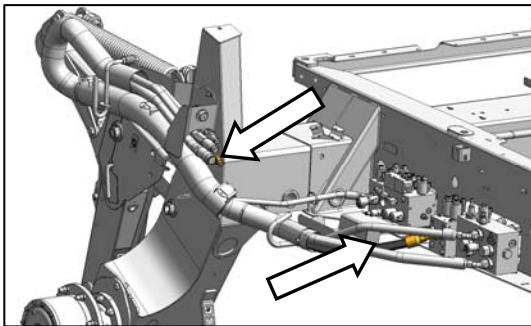

If required, configure the M200 to run an A40-D auger header by installing Kit B4651. The Kit includes the additional hose, hardware, and installation instructions.

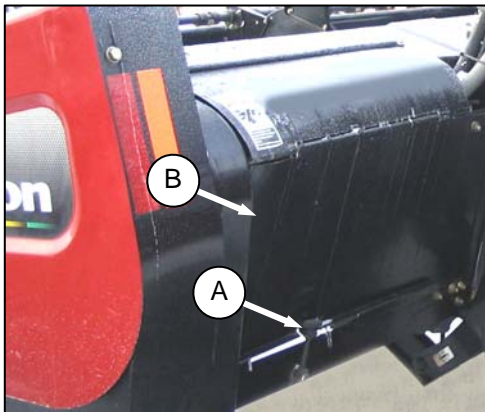

- a. Disengage rubber latch (A), and open driveline shield (B).

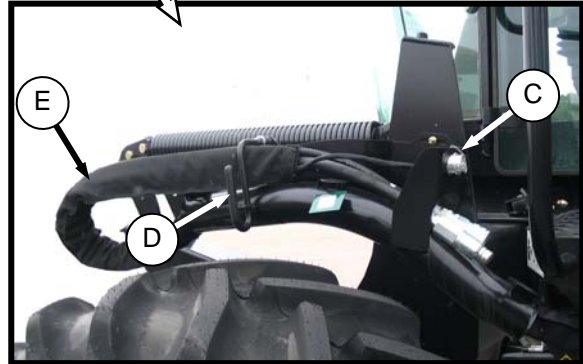

- b. Remove the cap (C) from electrical connector, and remove connector from support bracket.
- c. Disengage and rotate lever (D) counterclockwise to fully up position to release the hose bundle (E).

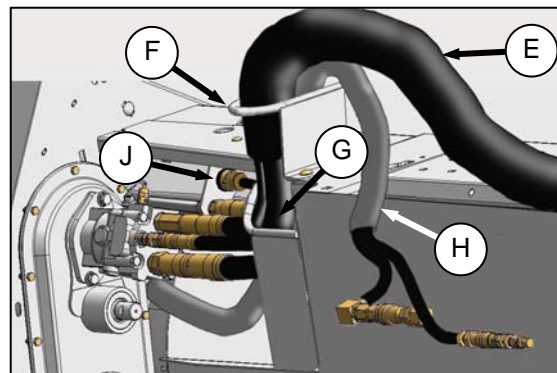

- d. Move hose/electrical bundle (E) to header.
- e. Route bundle (E) from windrower through support (F) and access hole (G) in header frame alongside existing hose bundle (H) from header.
- f. Remove cover on header electrical receptacle (J).
- g. Push connector onto receptacle, and turn collar on connector to lock it in place.
- h. Attach cover to mating cover on windrower wiring harness.
- i. Remove caps from hydraulic couplers, and clean if necessary.

(continued next page)

SECTION 6 OPERATION

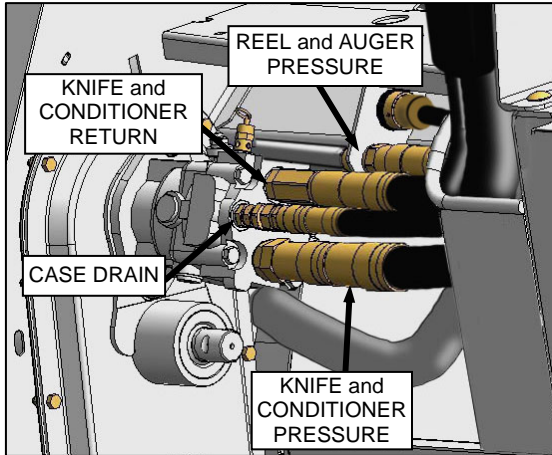

STANDARD HEADER

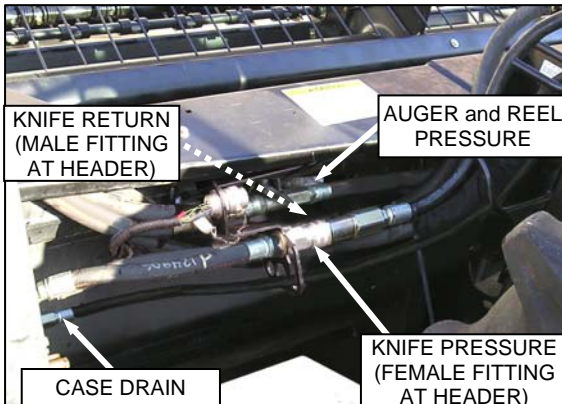

GRASS SEED HEADER

- j. Push hose connectors onto mating receptacles (as shown) until collars on receptacles snap into lock position.

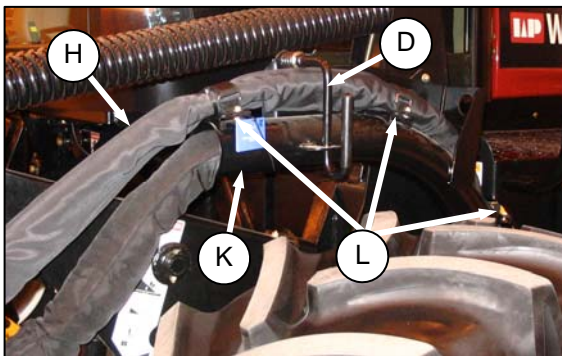

- k. Route auger return and reel pressure hose bundle (H) from header to windrower, and locate bundle above existing hose support (K) (as shown).
- l. Secure with three straps (L), and lower lever (D).

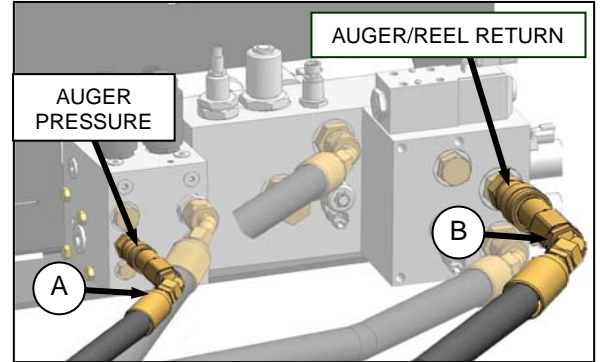
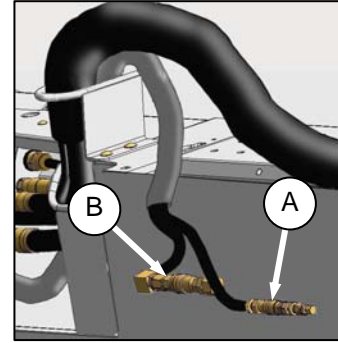

M200 - WITH REVERSER VALVE

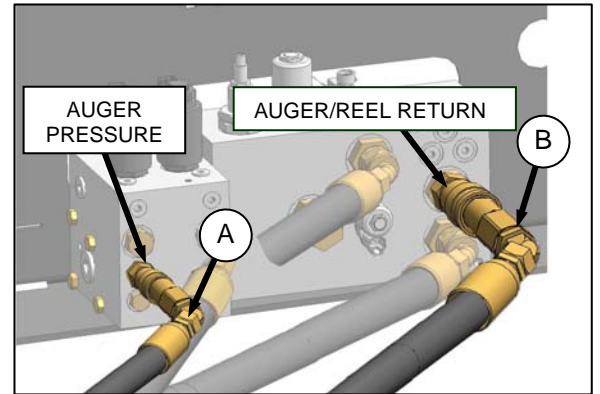

M200 - WITHOUT REVERSER VALVE

- m. If valve blocks are not configured as shown above, install required fittings as described in A30-S and A40-D Auger Self-Propelled Windrower Header Unloading and Assembly Instructions - MD Part #169078 that was supplied with your A40-D header.
- n. Push auger pressure (A) and auger/reel return (B) hose couplers onto mating receptacles on valve block until collar on receptacle snaps into lock position.
- o. Proceed to Section 6.6.3 *Configure Reverser Valve Jumper Hose*.

SECTION 6 OPERATION

6.6.2.4 M205



CAUTION

To prevent accidental movement of the windrower, place all controls in **NEUTRAL** or in **PARK**, engage park brake (if applicable), shut off engine, and remove key.

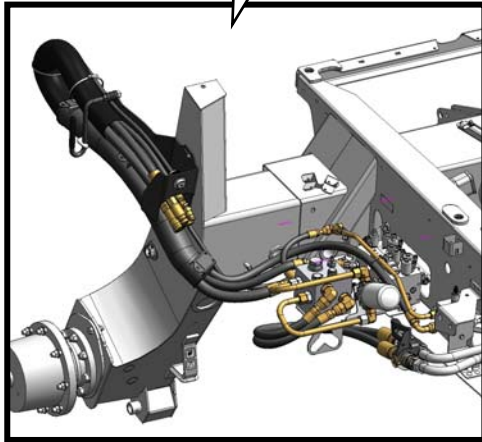

AUGER HEADER HYDRAULICS FOR M205

The M205 must be equipped with an auger drive basic kit and a completion kit as shown above. If necessary, obtain the following kits from your MacDon Dealer, and install them in accordance with the instructions supplied with the kit.

KIT DESCRIPTION	KIT NUMBER
Base Kit	B5491
Completion	B5492
Coupler	B5497

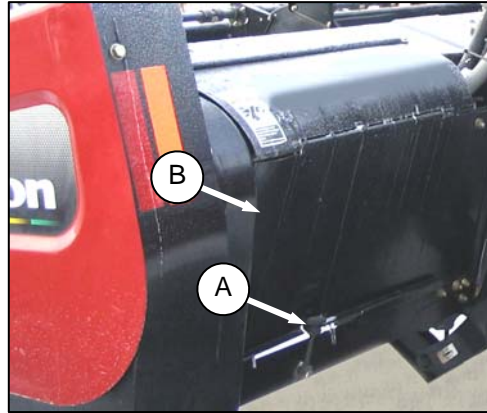

- a. Disengage rubber latch (A), and open driveline shield (B).

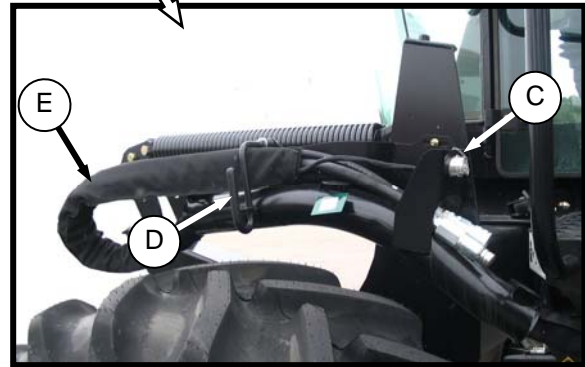

- b. Remove the cap (C) from electrical connector, and remove connector from support bracket.
- c. Disengage and rotate lever (D) counterclockwise to fully up position to release the hose bundle (E).
- d. Move hose/electrical bundle (E) to header.

(continued next page)

SECTION 6 OPERATION

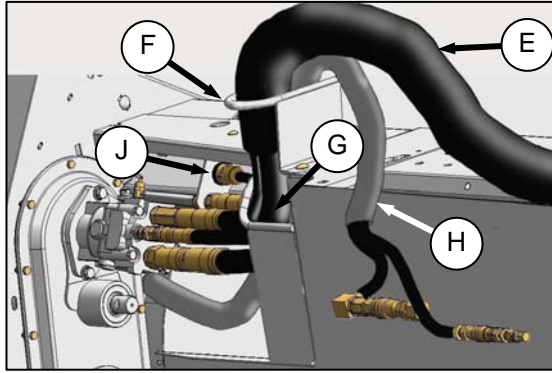

- e. Route bundle (E) from windrower through support (F) and access hole (G) in header frame alongside existing hose bundle (H) from header.
- f. Remove cover on header electrical receptacle (J).
- g. Push connector onto receptacle, and turn collar on connector to lock it in place.
- h. Attach cover to mating cover on windrower wiring harness.

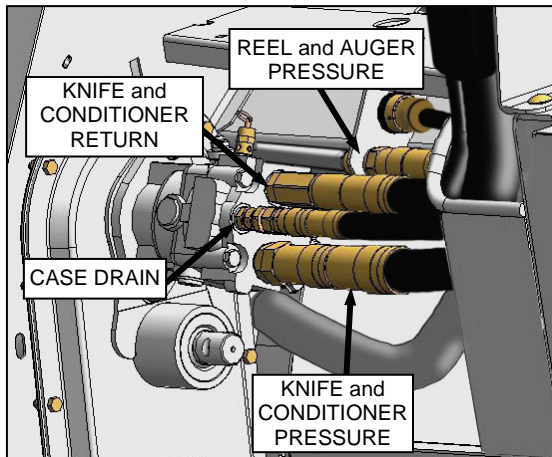

STANDARD HEADER

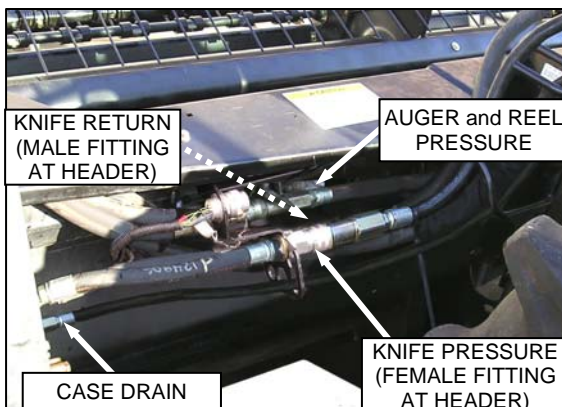

GRASS SEED HEADER

- i. Remove caps from hydraulic couplers, and clean if necessary.

- j. Push hose connectors onto mating receptacles (as shown) until collars on receptacles snap into lock position.

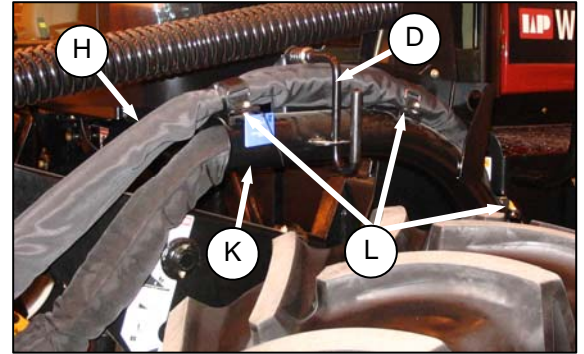

- k. Route auger return and reel pressure hose bundle (H) from header to windrower, and locate bundle above existing hose support (K) (as shown).
- l. Secure with three straps (L), and lower lever (D).

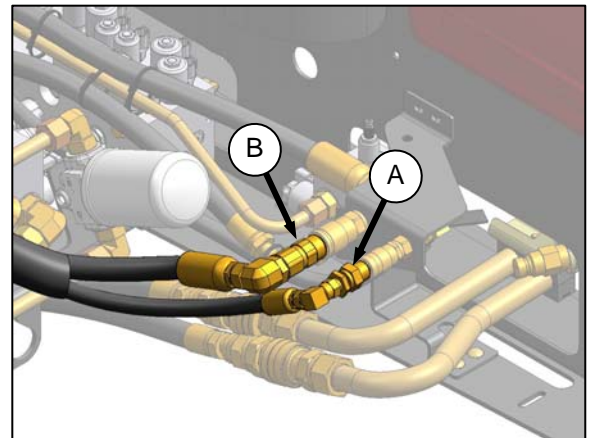

- m. Push auger/reel pressure (A) and auger/reel return (B) hose couplers onto mating receptacles on valve block until collar on receptacle snaps into lock position.
- n. Re-route header drive hoses. Refer to Section 6.6.2.1 M100, M105 step q. on page 37.

SECTION 6 OPERATION

6.6.3 Configure Reverser Valve Jumper Hose

An optional reverser valve block to reverse the header drive in the event of plugging, may have been installed on M150, M155, and M200 windrowers. A jumper hose on this valve block has a specific routing for each model of auger header. Check routing of the jumper hose as follows, and change as required:

- a. Move LH windrower platform to open position to expose hydraulic valve blocks.

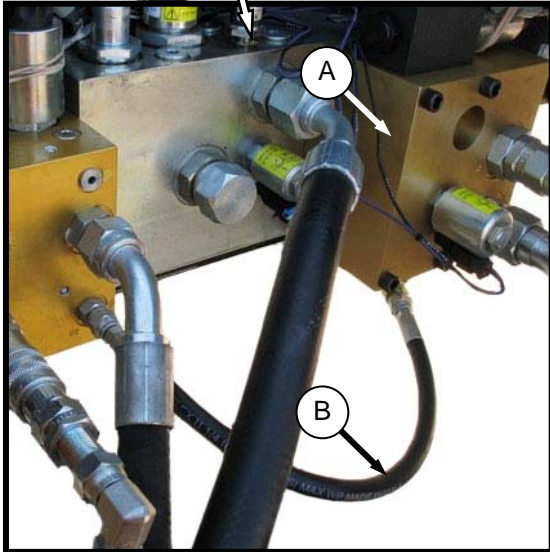

HOSE (B) POSITION - A40-D
M200 SHOWN - M150, M155 SIMILAR

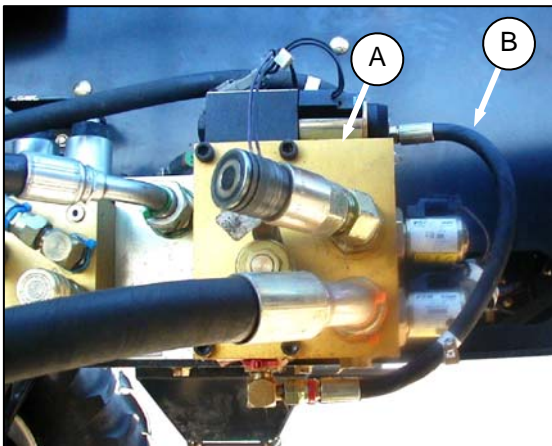

HOSE (B) POSITION - A30-S
M150 SHOWN - M155, M200 SIMILAR

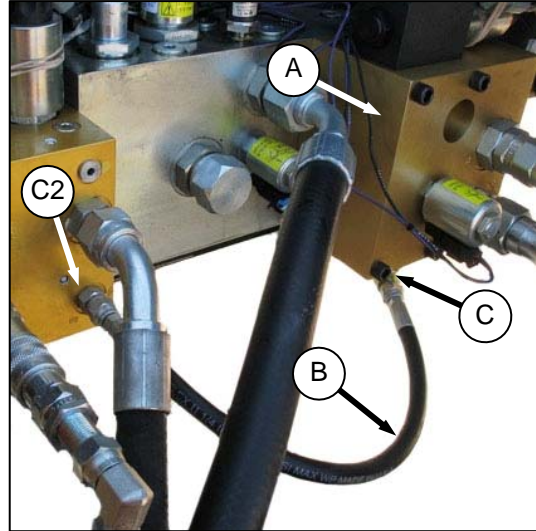

IMPORTANT

If a reverser valve block (A) has been installed, the jumper hose (B) must be routed as shown opposite. **Do not operate the headers unless hose is routed as shown.**

- b. To route hose (B) from A40-D position to A30-S position:
 1. Disconnect jumper hose (B) at header drive valve block port C2 fitting.
 2. Rotate 90° fitting (C) under reverser valve block (A) so that it points aft.

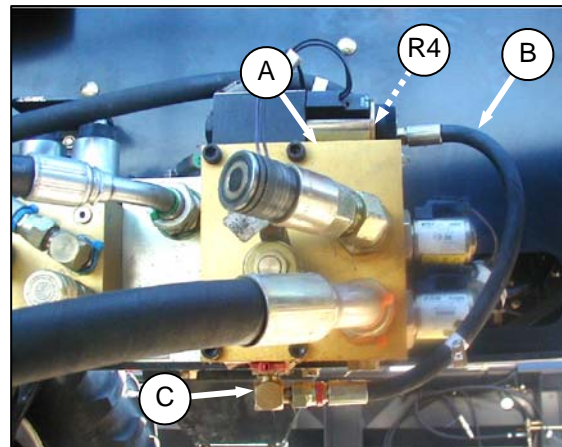

3. Remove cap from 90° fitting in port R4 on top of reverser block.
4. Connect jumper hose (B) onto 90° fitting in port R4.
5. Install cap removed in step 3. onto port C2 fitting.

(continued next page)

SECTION 6 OPERATION

- c. To route hose (B) from A30-S position to A40-D position:

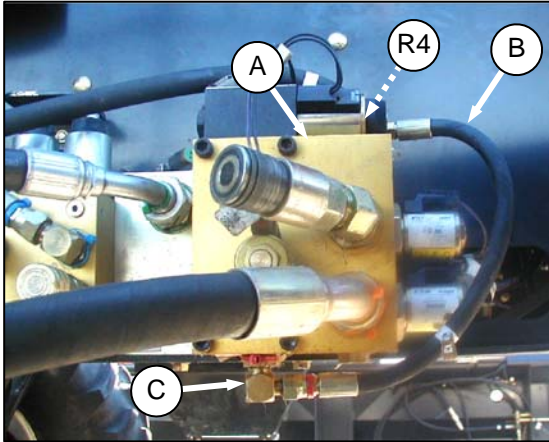

1. Disconnect jumper hose (B) at 90° fitting in port R4.

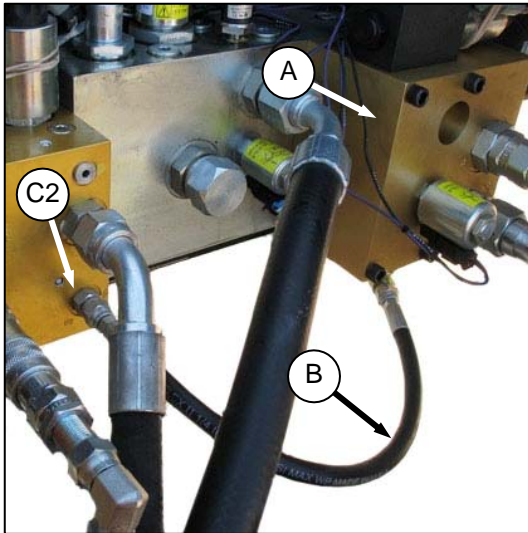

2. Rotate 90° fitting (C) under reverser valve block (A) so that hose can be routed to port C2 on header drive valve block.
 3. Remove cap from port C2 fitting on header drive valve block.
 4. Connect jumper hose (B) to port C2 fitting on header drive valve block.
 5. Install cap removed in step 3. onto 90° fitting in port R4 on reverser valve block (A).
- d. Move LH maintenance platform to normal operating position.

SECTION 6 OPERATION

6.7 HEADER DETACHMENT: SELF-PROPELLED



CAUTION

To prevent accidental movement of windrower, shut off engine, engage parking brake, and remove key.

6.7.1 A30-S Detachment

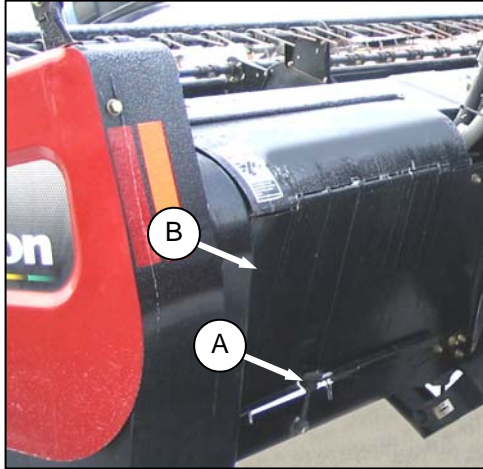

- a. Disengage rubber latch (A), and lift driveline shield (B) to open position.

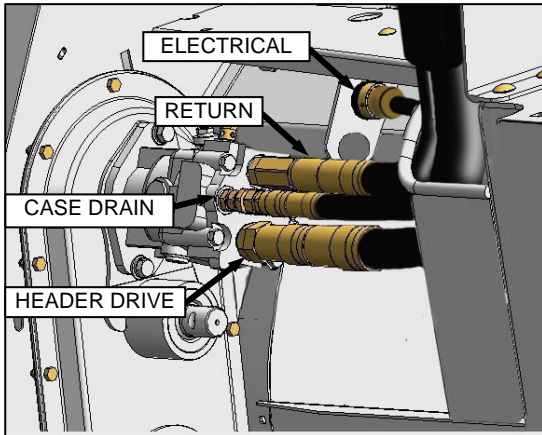

- b. Disconnect electrical connector by turning collar counterclockwise, and pulling connector to disengage.

- c. Disconnect hoses from hydraulic motor as follows:

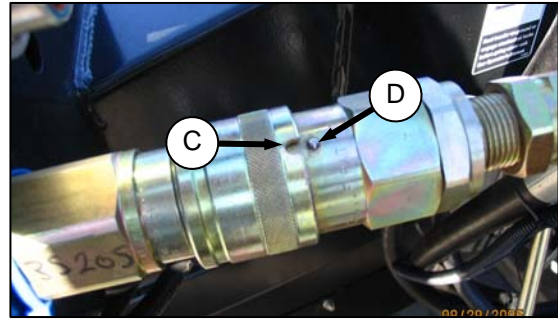

1. Line up slot (C) in collar with pin (D) on connector.
2. Push collar toward pin, and pull connector to disengage.
3. Install caps on connectors and hose ends (if equipped).

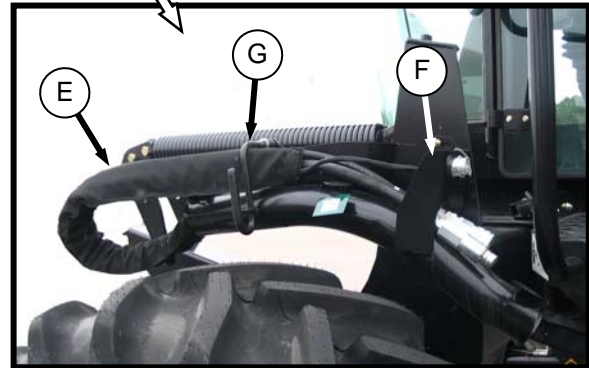

- d. Move hose bundle (E) from header, and locate on windrower LH side with hose ends in support (F) and under lever (G).
- e. Rotate lever (G) clockwise, and push to engage bracket.
- f. Locate electrical harness through support (F), and attach cap to electrical connector.
- g. Close header driveline shield, and move windrower platform to closed position.
- h. Check to ensure hoses and electrical harness clear tire.
- i. Detach header from windrower. Refer to your Self-Propelled Windrower Operator's Manual for procedures for mechanically detaching the header from the self-propelled windrower.

SECTION 6 OPERATION

6.7.2 A40-D Detachment



CAUTION

To prevent accidental movement of windrower, place all controls in **NEUTRAL** or in **PARK**, engage park brake (if applicable), shut off engine, and remove key.

- a. Move LH cab-forward platform to rear of windrower.

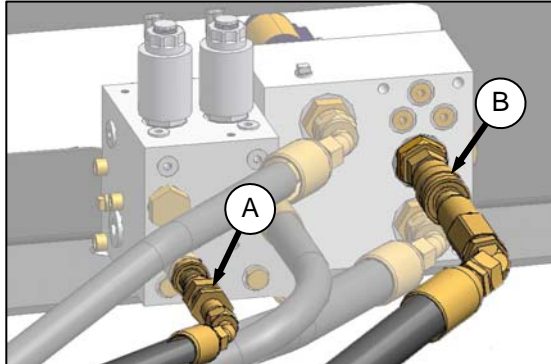

M150 WITHOUT REVERSER VALVE
M155, M200 SIMILAR

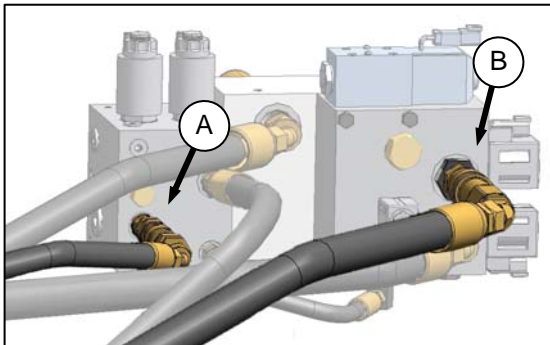

M150 WITH REVERSER VALVE
M155, M200 SIMILAR

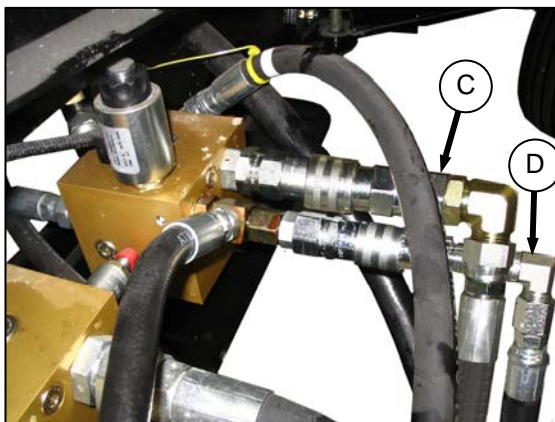

M100, M105

- b. Disconnect the two hydraulic hoses (A) and (B) or (C) and (D) from windrower valve(s).

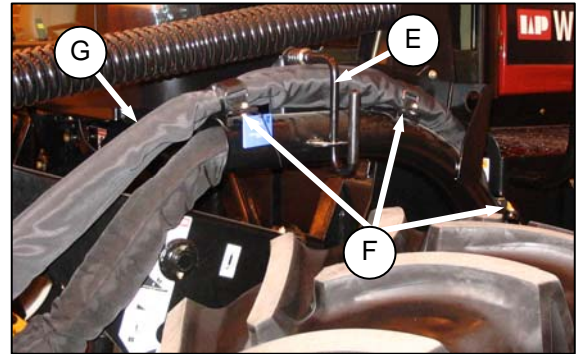

- c. Raise lever (E), and undo Velcro straps (F).
- d. Move hose bundle (G) to store on header walkway.

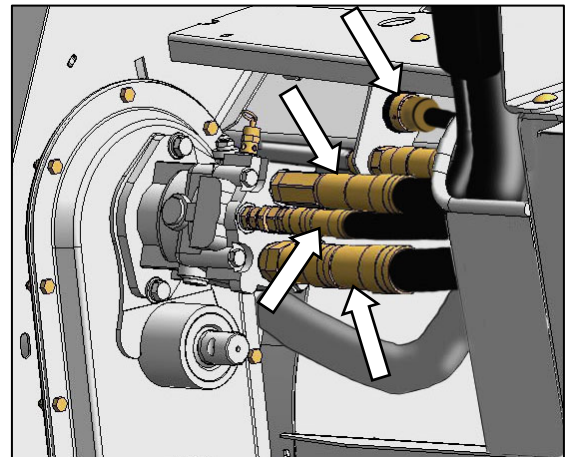

STANDARD HEADER

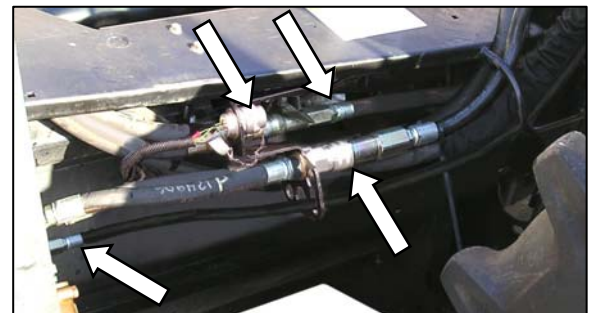

GRASS SEED HEADER

- e. Install caps on connectors and hose ends (if equipped).
- f. At the header, disconnect electrical connector by turning collar counterclockwise, and pulling connector to disengage.
- g. Disconnect hoses from hydraulic motor, and auger and reel pressure hose.

(continued next page)

SECTION 6 OPERATION

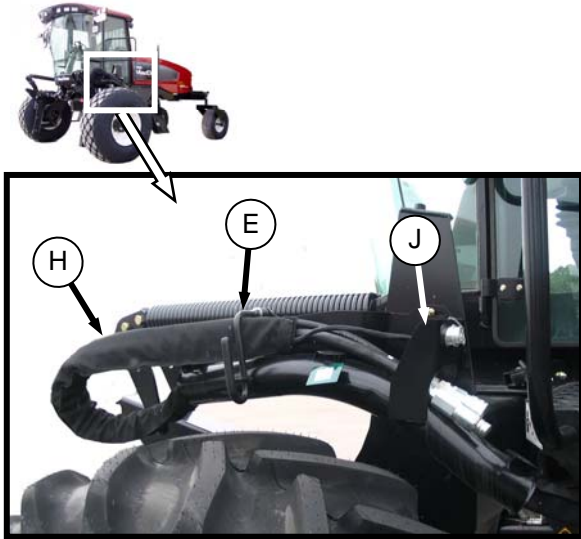

- h. Move hose bundle (H) from header, and locate on windrower LH side with hose ends in support (J) and under lever (E).
- i. Rotate lever (E) clockwise, and push to engage bracket.
- j. Locate electrical harness through support (J), and attach cap to electrical connector.
- k. Close driveline shield, and move windrower platform to closed position.
- l. Check to ensure hoses and electrical harness clear tire.
- m. Detach header from windrower. Refer to your Self-Propelled Windrower Operator's Manual for procedures for mechanically detaching the header from the self-propelled windrower.

SECTION 6 OPERATION

6.8 TRANSPORTING MOWER CONDITIONER

6.8.1 Self-Propelled

Refer to your Self-Propelled Windrower Operator's Manual for transporting headers when attached to the Windrower.

6.8.1.1 Amber Lights

The two hazard light fixtures are fitted with reversible amber and red reflector assemblies to accommodate cab-forward and engine-forward operation (M150, M155, M200, and M205).

The amber reflectors **must** always face the direction of travel, and are changed as follows:

- Lower header to the ground, shut off engine, and remove key.

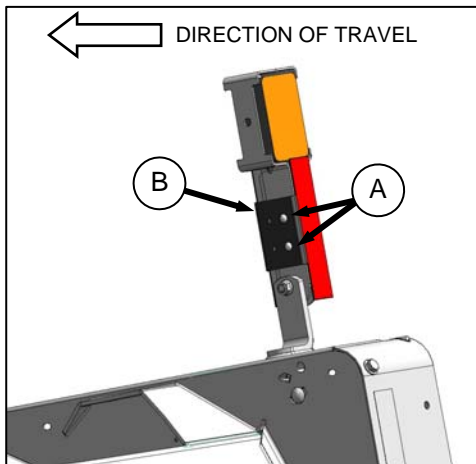

- Remove bolts (A) from deflector assembly (B), and remove assembly from light fixture. Retrieve spacers (nuts).

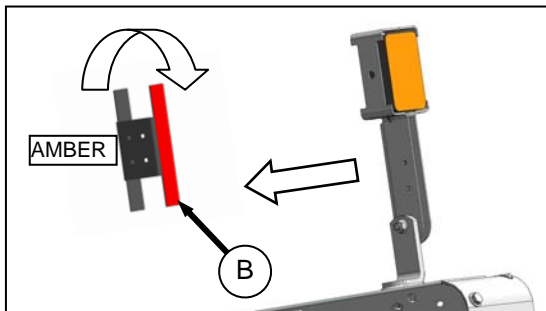

- Flip deflector assembly (B), and re-install ensuring amber side is facing direction of travel.

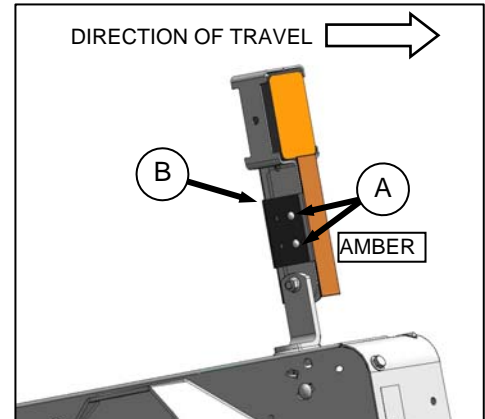

- Secure with bolts (A), spacers, and nuts.
- Repeat above steps for other light.

6.8.2 Pull-Type: Towing

The A Series Pull-Type Mower Conditioners can be transported on public roads by towing with a tractor or a truck. Proceed to Section 6.8.2.1 Transporting With A Tractor, or 6.8.2.2 Transporting With A Truck.



CAUTION

- Be aware of roadside obstructions, oncoming traffic and bridges.
- Travel speed should be such that complete control and machine stability are maintained at all times. Do not exceed 20 mph (32 km/h). Reduce speed for corners and slippery conditions.
- When transporting on roads, use tractor lights and mower conditioner flashing amber and red tail lights to provide adequate warning to Operators of other vehicles.
- Do **not** transport the mower conditioner on a road or highway at night, or in conditions, which reduce visibility, such as fog or rain.

6.8.2.1 Transporting With a Tractor

If the mower conditioner is in Transport mode, proceed as follows. Otherwise, see Section 6.8.2.3 Preparing Mower Conditioner for Transport.

- Hook-up mower conditioner to tractor. See Section 6.4 MOWER CONDITIONER/TRACTOR HOOK-UP: PULL-TYPE for details on attaching the mower conditioner to the tractor.

(continued next page)

SECTION 6 OPERATION

NOTE

The hydraulic hoses do not need to be attached to the tractor for towing. Ensure they are securely stored on the APT.

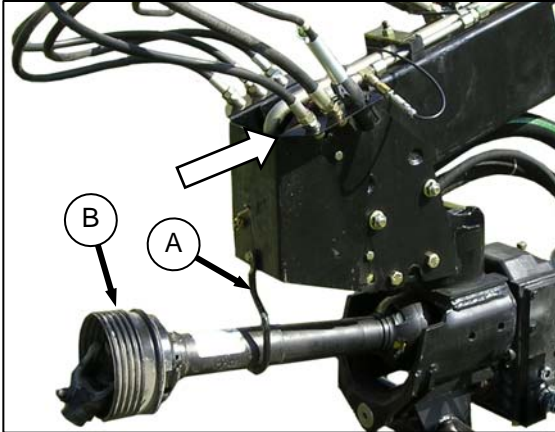

NOTE

The PTO does not need to be attached for towing purposes. If not attached, lower hook (A), store driveline on hook, and remove forward half (B) of driveline. Store forward half in cab for transport.

- b. Ensure that APT safety chain is properly attached to towing vehicle. Provide only enough slack in chain to permit turning.
- c. Check local laws for width regulations and lighting or marking requirements before transporting on roads.
- d. Do not exceed 20 mph (32 km/h).

6.8.2.2 Transporting With a Truck



CAUTION

Do not tow with a vehicle weighing less than 7500 lb (3400 kg). Ensure that the capacity of the towing vehicle is sufficient to maintain control.

If the mower conditioner is in Transport mode, proceed as follows. Otherwise, see Section 6.8.2.3 Preparing Mower Conditioner for Transport.

- a. Store hydraulic hoses on the APT as shown opposite.
- b. Lower hook (A), and place driveline in hook.
- c. Remove the forward half (B) of driveline, and store in truck for transport.

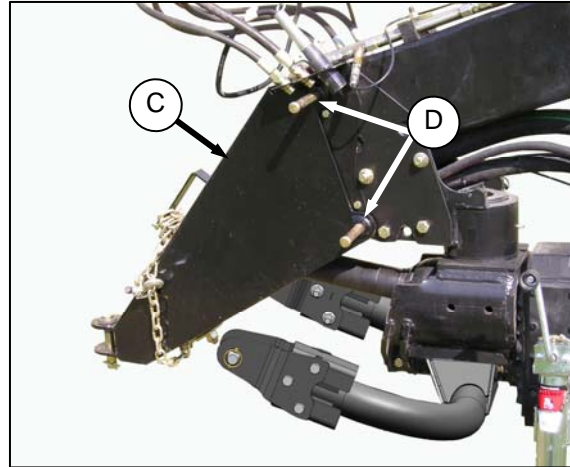

- d. Position towing adapter (C) on APT, and secure with pins (D).
- e. Attach mower conditioner to truck.
- f. Remove jack from working position, and store on APT. Secure with pin.

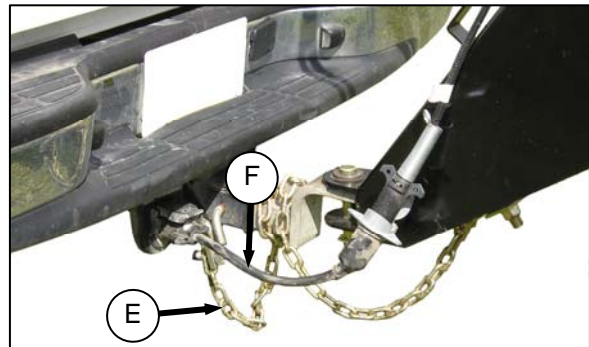

- g. Wrap safety chain around APT, and attach to truck frame (E).
- h. Connect electrical harness (F).
- i. Check local laws for width regulations and lighting or marking requirements before transporting on roads.
- j. Do not exceed 20 mph (32 km/h).

SECTION 6 OPERATION

6.8.2.3 Preparing Mower Conditioner for Transport

- a. Charge the steering circuit as follows:
 1. Connect two APT steering cylinder hoses to a tractor hydraulic circuit.
 2. Steer header completely to the left, then right. Repeat three or four times.
- b. Steer mower conditioner so that it is centered behind the towing vehicle.



- c. Close lock-out valve on the APT.



- d. Raise header fully, and engage both header lift cylinder lock-out valves.



WARNING

Do **not** tow unless the steering cylinder is fully charged. If steering cylinder is not fully charged, loss of control can result in injury or death. Use the temporary transport lock pin if machine must be towed without a fully charged steering cylinder.

- e. If steering cylinder is **not** fully charged, install temporary transport lock pin as follows: Otherwise, proceed to step f. below.

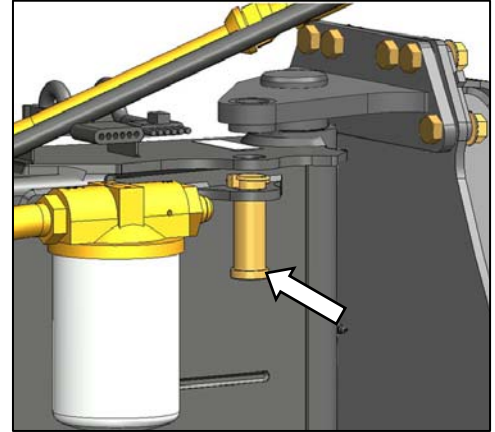

1. Remove pin from storage at aft end of APT.

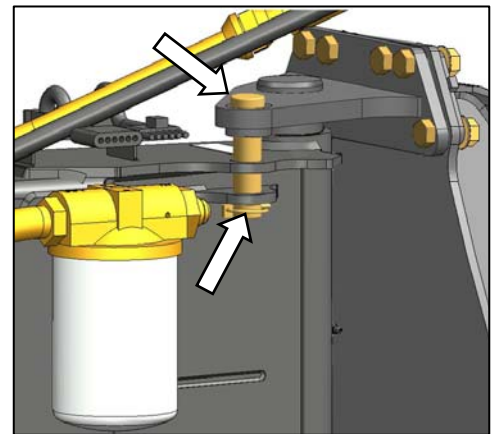

2. Line up holes in APT and frame, and install transport lock pin as shown.
3. Secure with lynch pin.

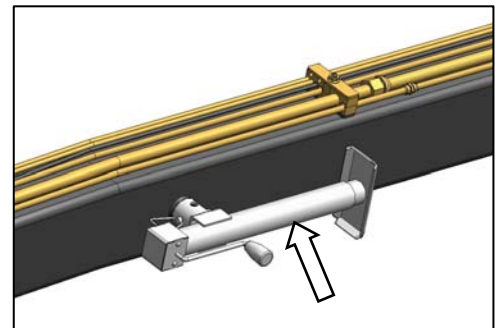

- f. Check that jack is properly attached in storage position on APT.
- g. Keep SMV sign, reflectors and lights clean and visible at rear of mower conditioner.
- h. Ensure tires are properly inflated.
- i. For towing procedures, refer to either Section 6.8.2.1 Transporting With A Tractor or Section 6.8.2.2 Transporting With A Truck.

SECTION 6 OPERATION

6.8.3 Pull-Type: Flatbed

To transport the mower conditioner on a flatbed trailer, proceed as follows:



CAUTION

Use the following procedure when transporting the mower conditioner on a flatbed trailer.

6.8.3.1 Loading: Pull-Type



- Lower mower conditioner to the ground, and move the cylinder lock-out valve handle to the horizontal position at both lift cylinders.
- Retract header angle control link to minimum.
- Unhook mower conditioner from tractor. Refer to Section 6.5 MOWER CONDITIONER/TRACTOR UNHOOK: PULL-TYPE.
- Tie hoses to APT.
- Remove tall crop dividers (if equipped) as follows:

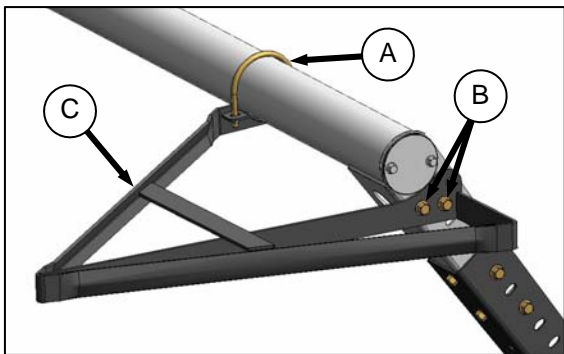

- Remove U-bolt (A) and bolts (B) securing crop divider (C) to lean bar, and remove crop divider.
- Repeat for crop divider at opposite end.

- Remove complete forming shield group as follows:

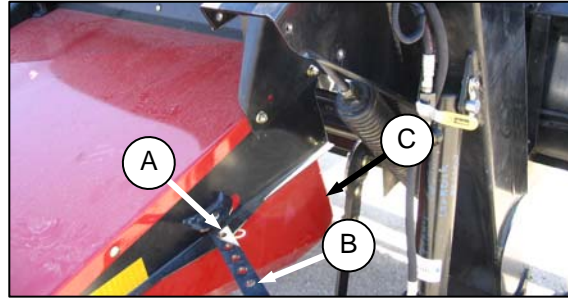

- Remove pins (A).
- Disassemble adjuster bars (B) from side deflectors (C). Note orientation of hardware.

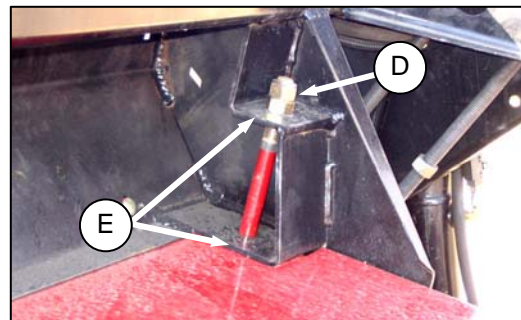

- Remove nuts (D), and drop side deflectors from frame (E).

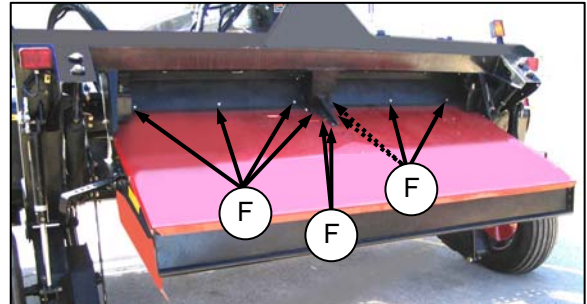

- Remove ten bolts (F) attaching forming shield cover to frame.

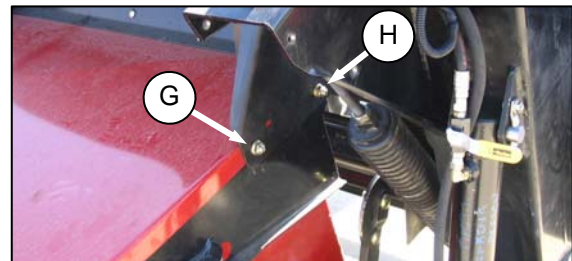

- Remove two bolts (G), and lower rear of forming shield to ground.
- Remove two bolts (H), and detach forming shield from frame.

(continued next page)

SECTION 6 OPERATION



- g. Remove pin at rod end of APT steering cylinder, and move cylinder away from frame. Re-insert pin in clevis.

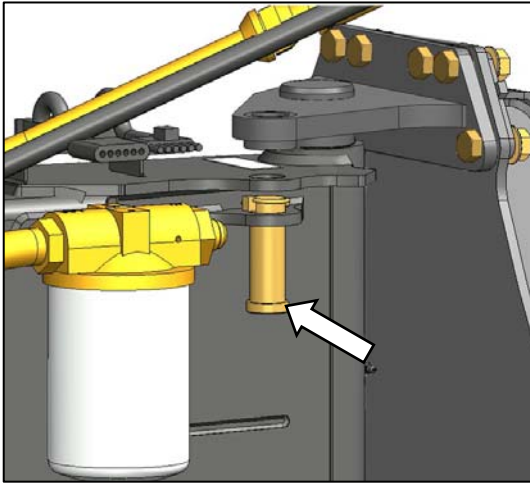

- h. Ensure temporary transport lock pin is in storage location.



WARNING

To avoid tipping over, the header must be resting on the ground prior to swinging the APT.



- i. Swing APT to the left as far as possible without damaging hydraulic lines.

IMPORTANT

The APT must not widen the shipping package.

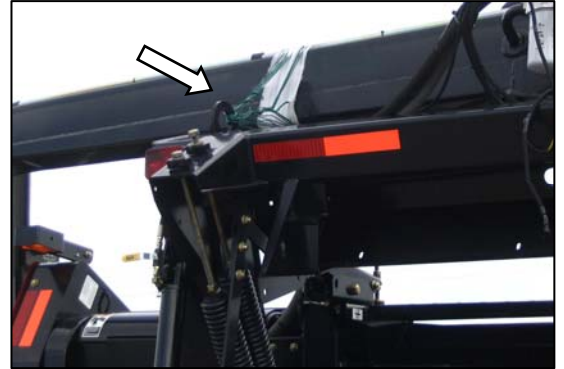

- j. Secure APT to frame hook to prevent movement. Use cardboard or suitable material under the tie to protect paint.

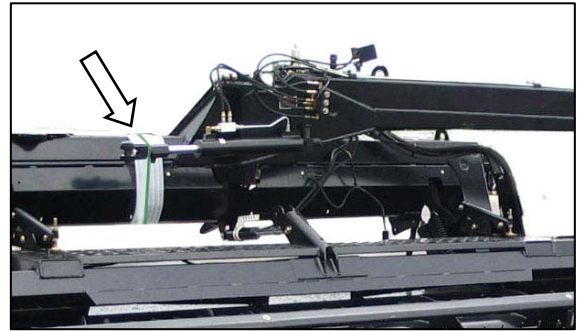

- k. Secure the steering cylinder to the frame with wire. Wrap tie around clevis, and use cardboard or suitable material under the tie to protect paint on the frame.



CAUTION

Equipment used for unloading must meet or exceed the requirements specified below. Using inadequate equipment may result in chain breakage, vehicle tipping or machine damage.

Lifting Vehicle:

Minimum Lifting Capacity: 8500 lb (3865 kg)
Minimum Lifting Height: 15 ft (4.5 m)

Chain:

Type: Overhead Lifting Quality (1/2 in)
Minimum Working Load: 5000 lb (2270 kg)

(continued next page)

SECTION 6 OPERATION

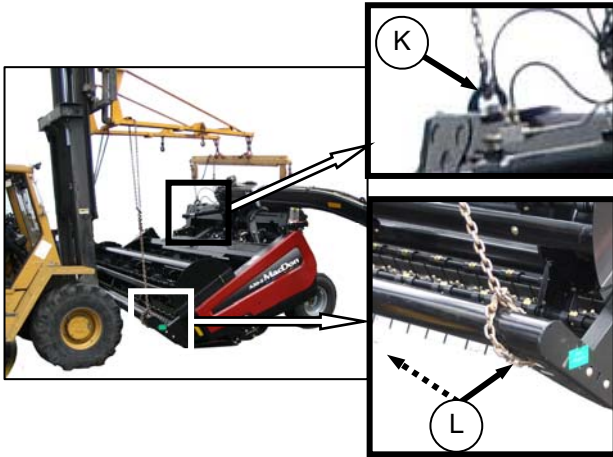

- l. Attach a chain to each frame hook (K) and a chain to each end of the lean bar at (L). Chain must pass through hole at end of lean bar.
- m. Position forklift from either front or back of mower conditioner, and lift slightly off the ground.



- n. Remove the wheels by removing bolt (M), and pulling wheel/axle assembly from frame.



- o. Lift mower conditioner, and back the flatbed trailer under the unit. The mower conditioner can be positioned with the APT towards the front or rear of the flatbed.



- p. Lower mower conditioner onto flatbed, so that its weight rests on the frame and sloped edge of header end panels, or cutterbar as shown.

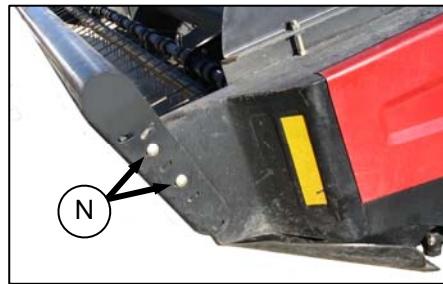

- q. Remove four bolts (N), and remove the lean bar to minimize load width. Secure lean bar to the flatbed.
- r. Tie the unit and the end of the APT down securely.

SECTION 6 OPERATION

6.8.3.2 Unloading: Pull-Type

- Remove tie downs.
- Install lean bar onto mower conditioner with four bolts (N) (shown on previous page)

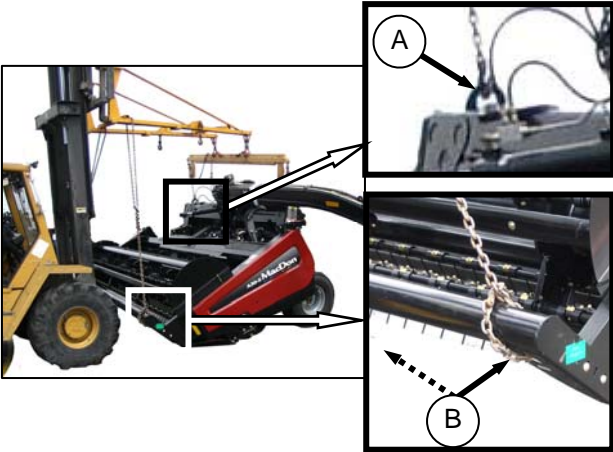

- Attach a chain to each frame hook (A), and a chain to each end of the lean bar at (B). Chain must pass through hole at end of lean bar.



CAUTION

Equipment used for unloading must meet or exceed the requirements specified below. Using inadequate equipment may result in chain breakage, vehicle tipping or machine damage.

Lifting Vehicle:

Minimum Lifting Capacity: 8500 lb (3865 kg)
Minimum Lifting Height: 15 ft (4.5 m)

Chain:

Type: Overhead Lifting Quality (1/2 in)
Minimum Working Load: 5000 lb (2270 kg)

- Position forklift from either front or back of mower conditioner, lift slightly off the flatbed, and move flatbed from beneath mower conditioner.



- Lower mower conditioner, and install wheel/axle assemblies onto mower conditioner. Secure axle to frame with bolt (C), and tighten to required torque..
- Lower mower conditioner to ground, and remove lifting chains.

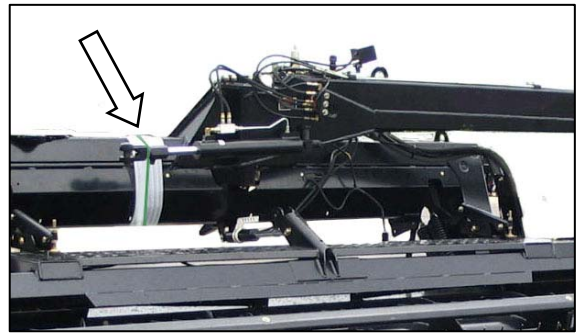

- Remove tie securing steering cylinder to frame.

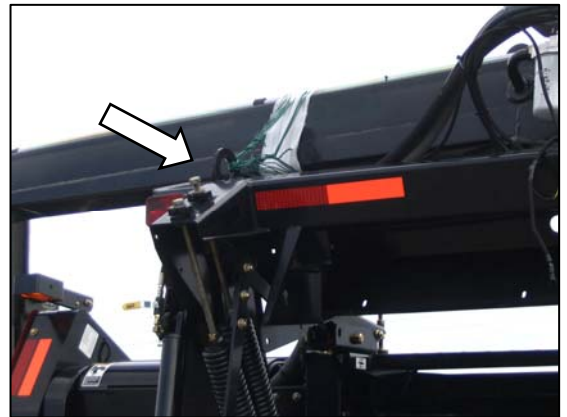

- Remove tie securing APT to frame.

(continued next page)

SECTION 6 OPERATION



- i. Swing APT to working position.

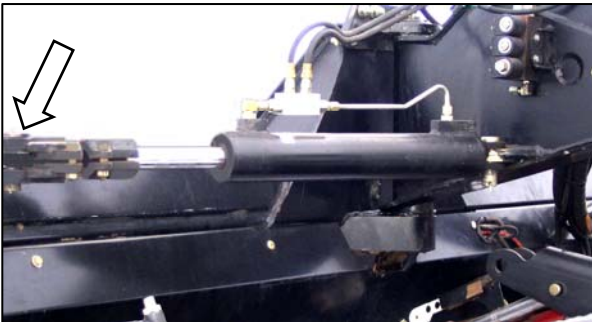

- j. Attach steering cylinder rod end to frame.
- k. Install rear forming shields using reverse order of step f. in Section 6.8.3.1 Loading: Pull-Type.



- l. Move lift cylinder lock-out valve handles to vertical position.

SECTION 6 OPERATION

6.9 BREAK-IN PERIOD

- a. After attaching header/mower conditioner to windrower/tractor for the first time, operate the machine slowly for 5 minutes, watching and listening FROM THE TRACTOR/WINDROWER SEAT for binding or interfering parts.

NOTE

Until you become familiar with the sound and feel of your new header/mower conditioner, be extra alert and attentive.



CAUTION

Before investigating an unusual sound or attempting to correct a problem, shut off tractor/windrower, engage parking brake and remove key.

- b. Perform steps in Section 7.18.1.1 Break-In Inspection: Self-Propelled or Section 7.18.2.1 Break-In Inspection: Pull-Type, depending on your machine.

6.10 PRE-SEASON CHECK



CAUTION

- Review the Operator's Manual to refresh your memory on safety and operating recommendations.
- Review all safety signs and other decals on the mower conditioner and note hazard areas.
- Be sure all shields and guards are properly installed and secured. Never alter or remove safety equipment.
- Be sure you understand and have practiced safe use of all controls. Know the capacity and operating characteristics of the machine.
- Check the first aid kit and fire extinguisher. Know where they are and how to use them.

Perform the following at the beginning of each operating season:

- a. Adjust tension on drive belts. Refer to Sections 7.8 SICKLE AND SICKLE DRIVE, 7.9 REEL AND REEL DRIVE: A30-S, A30-D and 7.11 AUGER AND AUGER DRIVE: A30-S, A30-D.
- b. Lubricate chains and adjust tensions. Refer to Sections 7.6.2 Lubrication Points, 7.9.1 Reel Drive Chain: A30-S, A30-D, and 7.11 AUGER AND AUGER DRIVE: A30-S, A30-D.

- c. Check tire pressure, and adjust as required. See Section 7.14.4 *Tire Inflation*.
- d. Perform all annual maintenance. See Section 7.18 MAINTENANCE SCHEDULE.

6.11 DAILY START-UP CHECK



CAUTION

- Be sure tractor/windrower and mower conditioner/header are properly attached, all controls are in NEUTRAL, and tractor/windrower brake is engaged.
- Clear the area of other persons, pets etc. Keep children away from machinery. Walk around the windrower / mower conditioner to be sure no one is under, on, or close to it.
- Wear close fitting clothing and protective shoes with slip resistant soles.
- Remove foreign objects from the machine and surrounding area.
- As well, carry with you any protective clothing and personal safety devices that COULD be necessary through the day. Don't take chances.
- You may need:

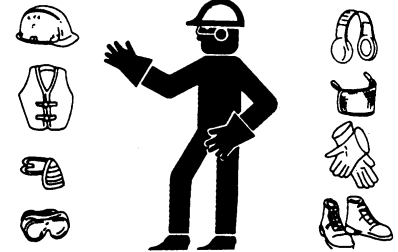

- a hard hat
- protective glasses or goggles
- heavy gloves
- respirator or filter mask
- wet weather gear
- Protect against noise. Wear a suitable hearing protective device such as ear muffs or ear plugs to protect against objectionable or uncomfortable loud noises.



(continued next page)

SECTION 6 OPERATION

Do the following each day before start-up:

- Check the machine for leaks or any parts that are missing, broken, or not working correctly.

NOTE

Use proper procedure when searching for pressurized fluid leaks. Refer to Section 7.7.3 Hoses and Lines.

- Clean all lights and reflective surfaces on the machine. Check lights for proper operation.
- Perform all Daily maintenance. Refer to Section 7.18 MAINTENANCE SCHEDULE.

6.12 SHUTDOWN PROCEDURE



CAUTION

Before leaving the tractor/windrower seat for any reason:

- Park on level ground if possible.
- Lower header / mower conditioner fully.
- Place all controls in NEUTRAL or PARK.
- Disengage PTO.
- Engage the park brake.
- Stop engine, and remove key from ignition.
- Wait for all movement to stop.
- Lock tractor/windrower anti-vandalism covers and closures when leaving the machine unattended.

6.13 ENGAGING THE PTO: PULL-TYPE



DANGER

Be sure all bystanders are clear of the machine before engaging the PTO. Never leave tractor seat with the PTO engaged.

- Engage PTO slowly, just before the mower conditioner is moved up to the standing crop.
- Be sure tractor PTO is running at correct rpm before starting to cut (1000 rpm).
- Disengage PTO when not operating the mower conditioner.

6.14 LIFT CYLINDER LOCK-OUTS



WARNING

To avoid bodily injury or death from fall of raised machine, always lock-out lift cylinders before going under mower conditioner for any reason.

6.14.1 Self-Propelled

Refer to your Self-Propelled Windrower Operator's Manual for details on the lift cylinder locks.

6.14.2 Pull-Type

- Raise machine to maximum height by activating remote cylinder control valve in tractor.

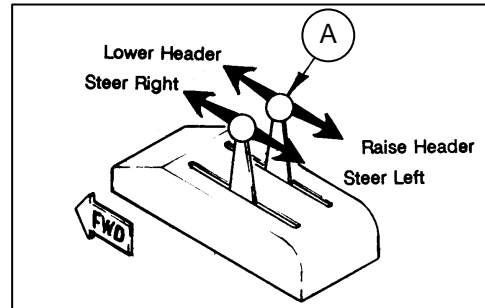

IMPORTANT

Hoses should be connected so that moving control lever (A) backward raises the header.



NORMAL

CLOSED

- Close lock-out valve on each lift cylinder by turning the handle to the horizontal position.
- To return to normal operation, turn handle on the lock-out valves to the vertical position.

SECTION 6 OPERATION

6.15 STEERING: PULL-TYPE

Steering the mower conditioner is controlled by the tractor's remote hydraulic system. This steering system allows the mower conditioner to follow directly behind the tractor, make a full cut to either side, or any position in-between.

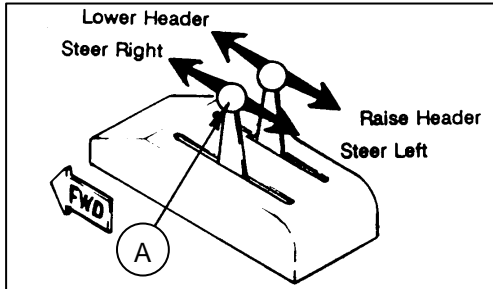

IMPORTANT

Hoses should be connected so that moving tractor control lever (A) FORWARD steers machine to the RIGHT, and moving lever (A) BACKWARD steers machine LEFT.

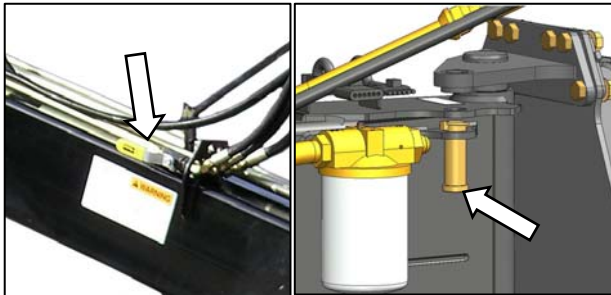

IMPORTANT

To allow APT to swing, the valve on the APT must be in the working or open position (handle in-line with APT), and the temporary transport lock pin must be in the storage location.

The center pivot provides the Operator the opportunity to:

- easily move the mower conditioner into the field position,
- make right angle turns in either direction,
- steer around objects on both sides, and
- perform straight line field cutting on either side of the tractor.

The control is operated momentarily for steering, and must be returned to OFF or NEUTRAL position as soon as the mower conditioner reaches the desired path of travel.

6.15.1 Right Side Operation: Pull-Type

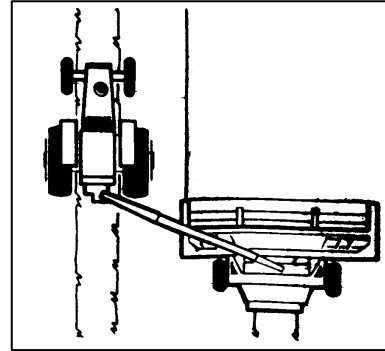

Move steering lever FORWARD to achieve desired position of mower conditioner on RIGHT side of tractor.

To adjust tracking of mower conditioner during right side operation, the steering cylinder clevis can be re-positioned:



CAUTION

Stop engine, and remove key from ignition before leaving Operator's seat for any reason. A child or even a pet could engage an idling machine.

- Shut down tractor, and remove key.

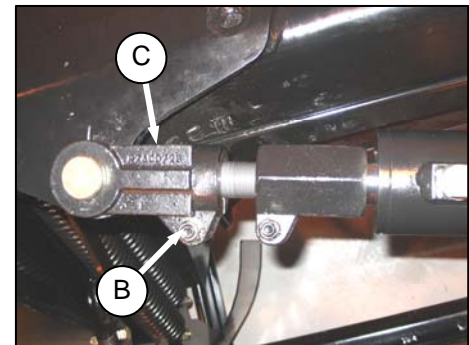

- Loosen clamping bolt (B) on clevis (C).
- Using a wrench on the stroke control (B), rotate cylinder rod so that clevis moves away from or closer to the cylinder. **Each turn of the rod changes the tracking by approximately 2 in. (50 mm).**

DESIRED TRACK	CYLINDER EXTENSION	CLEVIS POSITION
Further RIGHT	Increase	Clevis (C) Further From Cylinder
Further LEFT	Decrease	Clevis (C) Closer To Cylinder

- Tighten clamping bolt to 65 ft-lbf (90 N-m).
- Re-check torque on clamping bolt after 1 hour, and every 100 hours thereafter.

SECTION 6 OPERATION

6.15.2 Left Side Operation: Pull-Type

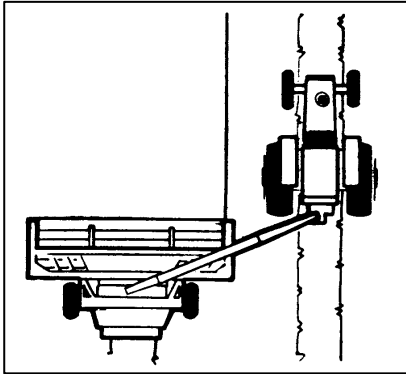

Move steering lever backward to achieve desired position of mower conditioner on LH side of tractor.

To adjust tracking of mower conditioner during LH side operation, the steering cylinder stroke control can be re-positioned:

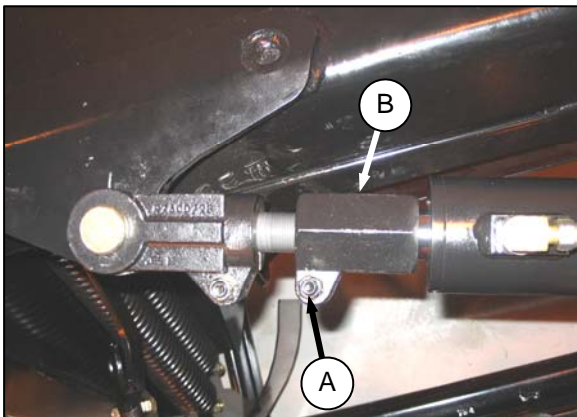

- Loosen clamping bolt (A) on stroke control (B), and rotate stroke control to desired position.

Each turn of the stroke control changes the tracking by approximately 2 in. (50 mm).

DESIRED TRACK	CYLINDER STROKE	STROKE CONTROL POSITION
Further LEFT	Decrease	Rotate Stroke Control (B) Away From Clevis.
Further RIGHT	Increase	Rotate Stroke Control (B) Towards Clevis.

- Tighten clamping bolt to 65 ft·lbf (90 N·m).
- Re-check torque on clamping bolt after 1 hour, and every 100 hours thereafter.

IMPORTANT

The adjustment for right side operation must be done prior to adjustment for LH side operation.

6.15.3 Avoiding Obstacles

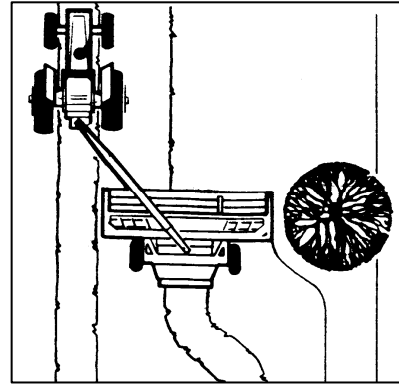

Move steering lever as required to avoid obstacles.

6.15.4 Square Corners

The following procedure is intended only as a guide to developing a turning procedure for the tractor being used. Specific distances are not given due to the variances in tractor manoeuvrability.

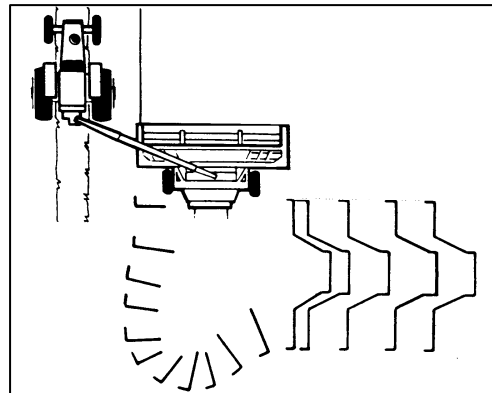

- As tractor approaches the corner, guide tractor sharply away from the crop. Steer the mower conditioner to maintain a straight cut ahead, as the tractor moves away from the crop.
- As soon as the sickle cuts past where the new corner will be, raise the header sufficiently for skid shoes to clear the ground, then steer the mower conditioner to the extreme direction away from the uncut crop.
- As the tractor passes the corner, steer it sharply back towards the uncut crop, taking care that the inside tractor tire does not contact the mower conditioner APT.
- Guide the tractor to straddle the last cut windrow. As the mower conditioner finishes turning, steer it back towards the uncut crop, align the header with the crop edge, and lower header to cutting height.

SECTION 6 OPERATION

6.15.5 180 Degree Turn

NOTE

When cutting back and forth on one side of the field, approximately 50 ft. (15 m) is required at each end of the field to make a 180 degree turn-around.

Refer to illustration below, and proceed as follows:

- a. Beginning at position (A), the tractor is guided away from the uncut crop, while the mower conditioner is guided straight ahead until cutting through the end.
- b. As soon as the sickle cuts through, raise header to lift the skid shoes clear of the ground, and steer mower conditioner to the extreme direction away from the uncut crop.

NOTE

For ease of operation, both levers can be activated with one hand, and held until steering cylinder completes its stroke.

- c. At position (B), start turning tractor back towards the uncut crop.

IMPORTANT

When turning, take care that inside tractor tire does not contact APT of mower conditioner.

- d. In positions (C) and (D), continue turning towards the uncut crop, (with the mower conditioner steered towards the outside of the turning circle), being aware of APT-to-tire clearance.
- e. At position (E), the tractor completes the circle, and front wheels are turned to straddle the last cut windrow. At this point, steer the mower conditioner to line up with the edge of the uncut crop.
- f. At position (F), lower header to cutting height, and begin a new cut through the field.

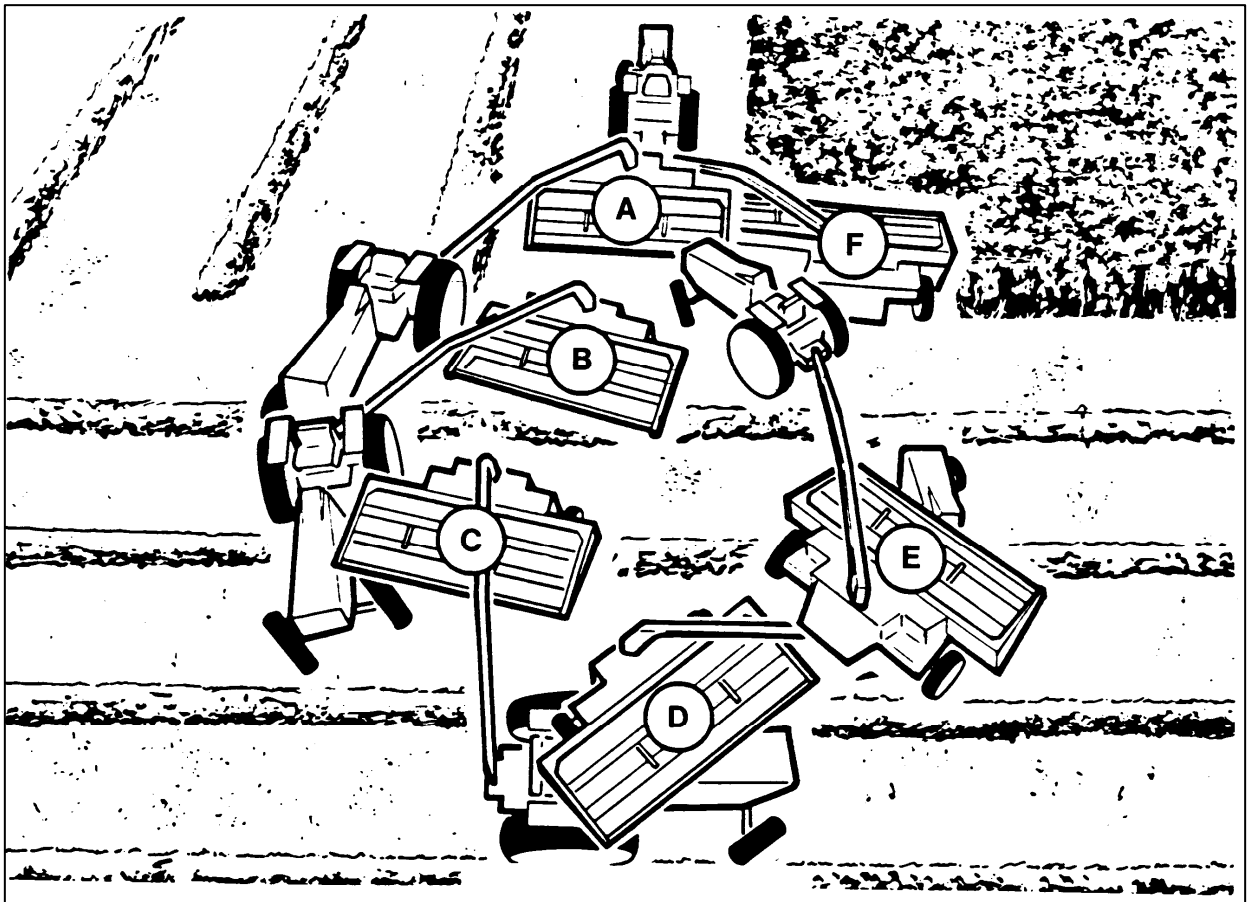

SECTION 6 OPERATION

6.16 UNPLUGGING THE HEADER / MOWER CONDITIONER

6.16.1 Unplugging Conditioner: Pull-type



WARNING

Stop tractor engine, and remove key before removing plugged material from mower conditioner. A child or even a pet could engage the drive.

- Stop forward movement of the tractor, and stop the PTO.
- Raise the machine, and slowly engage the PTO.

NOTE

Raising the mower conditioner automatically raises the top roll to ease plug removal.

- If plug does not clear, with machine still raised, shut off engine, remove key, and lock tractor brakes.
- Engage lift cylinder lock-out valves.



WARNING

Wear heavy gloves when working around sickle.

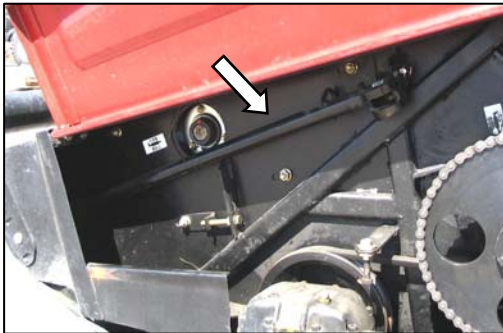

- Clean off cutterbar and area under reel by hand.



- Retrieve wrench from storage inside the LH drive compartment.

- Use wrench on LH end of primary driveshaft to turn rolls forward until plug clears.
- Return wrench to storage location, and secure in place with pin.



WARNING

Return unplug wrench to storage location, and close LH driveshield before re-starting machine.

NOTE

If plugging persists, see Section 8 TROUBLESHOOTING.

6.16.2 Unplugging Conditioner: Self-Propelled - A30-S

Reverse the header drive. Refer to your Self-Propelled Windrower Operator's Manual for procedures on reversing the header drive.

6.16.3 Unplugging Sickle

- Stop forward movement of windrower, and shut down header.
- Lift cutterbar about 12 in. (300 mm).
- Back up about 3 feet (1 metre) while slowly engaging the header.
- If plug does not clear; raise machine, apply windrower brake, shut off engine, and remove key.



WARNING

Stop windrower engine, and remove key before removing plugged material from header. A child or even a pet could engage the drive.

- Engage lift cylinder lock-outs.



WARNING

Wear heavy gloves when working around sickle.

- Clean off cutterbar by hand.

NOTE

If sickle plugging persists, see Section 8 TROUBLESHOOTING.

SECTION 6 OPERATION

6.17 HEADER OPERATION

Satisfactory function of the windrower in all situations requires making proper adjustments to suit various crops and conditions.

Correct operation reduces crop loss and allows cutting of more acres. As well, proper adjustments and timely maintenance will increase the length of service you receive from the machine.

The variables listed below and detailed on the following pages will affect the performance of the windrower. You will quickly become adept at adjusting the machine to give you the desired results.

VARIABLE	SECTION
Lean Bar Position	6.17.1
Auger Speed	6.17.2
Reel Speed	6.17.3
Auger Position	6.17.4
Reel Position	6.17.5
Tine Aggressiveness Adjustment	6.17.6
Cutting Height	6.17.8
Header Angle	6.17.9
Header Flotation	6.17.10
Feed Pan / Rock Drop Tine Position	6.17.11
Roll Gap/Timing/Alignment	6.17.12
Roll Tension	6.17.13
Forming Shields	6.17.14
Tall Crop Dividers	6.17.15
Ground Speed	6.17.16

6.17.1 Lean Bar Position

IMPORTANT

To prevent structural damage to the header, do not operate with lean bar removed.

Use the lean bar adjustment to accommodate different crop heights.

The lean bar should strike the upper portion of the crop, leaning it away from the header, and exposing the stalks to the sickle.

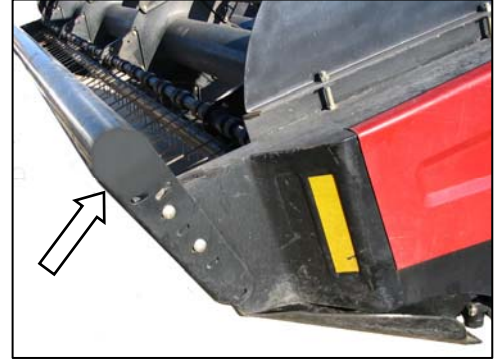

To extend or retract lean bar, re-position hardware in adjustment holes as required. Refer to illustration.

See also Section 6.17.15 *Tall Crop Dividers*.

SECTION 6 OPERATION

6.17.2 Auger Speed

Auger speed must be high enough to carry crop into the conditioner, and yet not throw it out.

In light crops, a lower throttle setting on the tractor/windrower will slow down the header/mower conditioner operating speed, and help to prevent carryover.

6.17.2.1 Auger Speed: A30-S and A30-D

The A30 auger speed is fixed to the engine rpm, and an optional 19 tooth drive sprocket provides lower auger speeds.

Refer to Section 5 SPECIFICATIONS for available auger speeds at rated tractor/windrower RPM.

Change auger drive sprockets as follows:



CAUTION

Stop engine, and remove key from ignition before leaving Operator's seat for any reason. A child or even a pet could engage an idling machine.

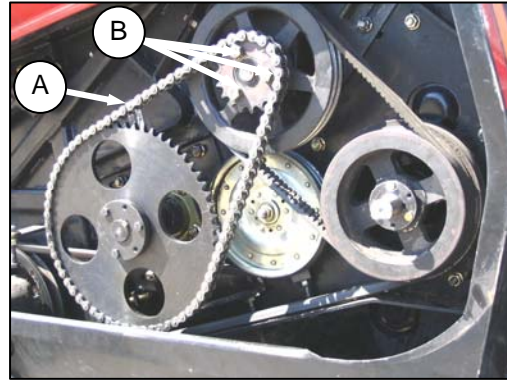

A30-S

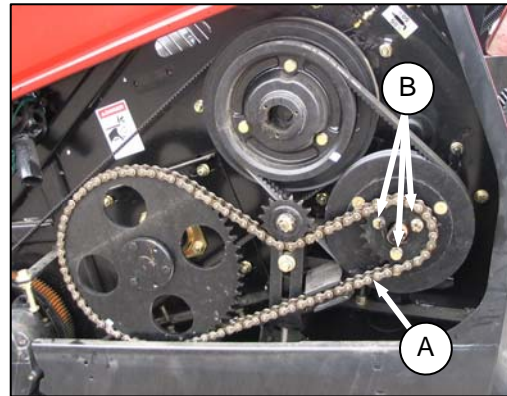

A30-D

- Remove auger drive chain (A). Refer to Section 7.11 AUGER AND AUGER DRIVE: A30-S, A30-D.
- Remove three bolts (B) attaching sprocket to pulley, and remove sprocket.
- Attach applicable sprocket to pulley with three bolts, and torque to 75 ft·lbf (102 N·m).
- Replace auger drive chain (A). Refer to Section 7.11 AUGER AND AUGER DRIVE: A30-S, A30-D.

6.17.2.2 Auger Speed: A40-D

The A40-D auger header features a hydraulic direct drive auger with operating speed range of 230 to 320 rpm, and is controlled from the Operator's station on the self-propelled windrower.

Refer to your Self-Propelled Windrower Operator's Manual.

SECTION 6 OPERATION

6.17.3 Reel Speed

For best feeding of the crop into the header/mower conditioner, reel speed must be faster than ground speed. This gently sweeps material across the sickle into the auger.

A slower reel speed will reduce crop carry-over, while a faster reel speed will result in a more even stubble height in down and tangled crops.

6.17.3.1 Reel Speed: A30-S, A30-D

The A30 reel speed is fixed to the engine rpm and auger speed. An optional 19 tooth drive sprocket provides lower reel speeds if necessary.

Refer to Section 5 SPECIFICATIONS for available reel speeds at rated tractor/windrower RPM.

Change auger drive sprockets as follows:



CAUTION

Stop engine, and remove key from ignition before leaving Operator's seat for any reason. A child or even a pet could engage an idling machine.

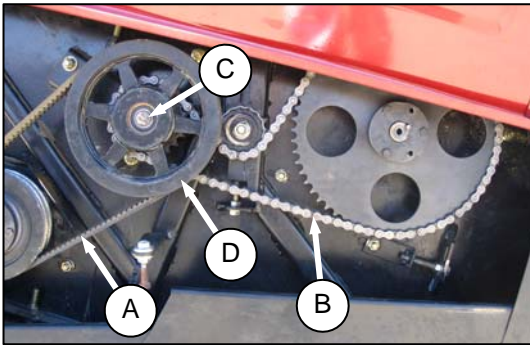

- Remove reel drive belt (A) and reel drive chain (B) from drive sprocket. Refer to Sections 7.9.1 *Reel Drive Chain: A30-S, A30-D* and 7.9.2 *Reel Drive Belts: A30-S, A30-D*.
- Remove snap-ring (C) from pulley (D), and remove pulley.
- Remove three bolts attaching sprocket to pulley, and remove sprocket.
- Attach applicable sprocket to pulley with three bolts, and torque to 75 ft-lbf (102 N·m).
- Replace pulley, and install snap-ring.
- Replace reel drive chain and belt. Refer to Sections 7.9.1 *Reel Drive Chain: A30-S, A30-D* and 7.9.2 *Reel Drive Belts: A30-S, A30-D*.

6.17.3.2 Reel Speed: A40-D

The A40-D auger header features a hydraulic direct drive reel with operating speed range of 15 to 85 rpm (M150, M155, M200, M205), 15 to 50 rpm (M100, M105), and is controlled from the Operator's station on the self-propelled windrower.

Refer to your Self-Propelled Windrower Operator's Manual.

SECTION 6 OPERATION

6.17.4 Auger Position



CAUTION

To avoid personal injury, before servicing header/mower conditioner or opening drive covers, follow procedures in Section 7.1 PREPARATION FOR SERVICING.

Auger position has been factory-set, and should not normally require adjustment.

For nearly all conditions, the auger performs best when set as close as possible to the stripper bars without rubbing. This is especially important in grass and other crops that have a tendency to wrap.

Component wear may cause clearances to become excessive, resulting in feeding problems and uneven windrows.

To make adjustments to auger position, refer to the Sections 6.17.4.1 to 6.17.4.6.

NOTE

In heavier crops it may be necessary to remove the front stripper bar for smoother crop flow across the auger. Refer to Section 7.11.7 Stripper Bars.

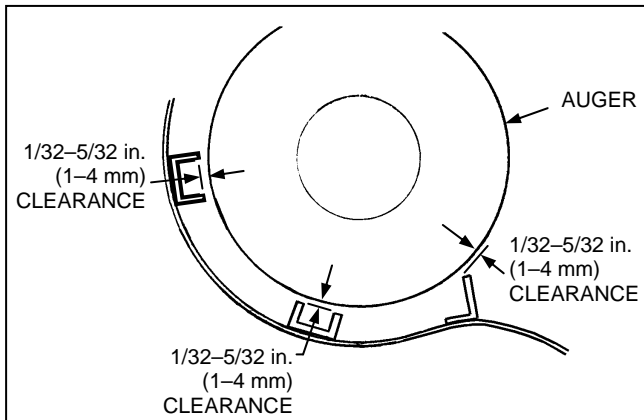

NOTE

The auger should clear the stripper bars on the auger pan by approximately 1/32-5/32 in. (1-4 mm). Shimming the stripper bars may be required. Refer to Section 7.11.7 Stripper Bars.

6.17.4.1 Auger Fore-Aft Adjustment: A30-S

- Open LH endshield.
- Loosen auger drive chain (A) as follows:

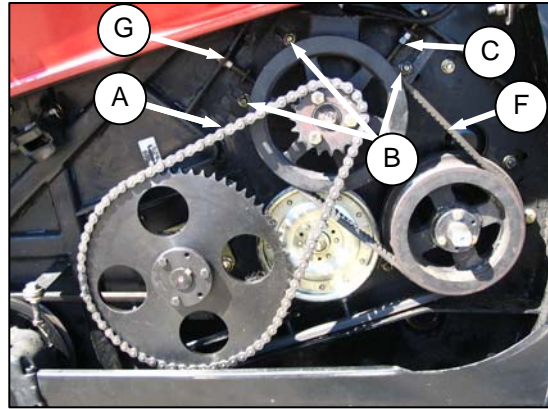

- Loosen three bolts (B).
- Loosen jam nut on adjuster bolt (C), and turn adjuster bolt (C) to loosen chain (A).

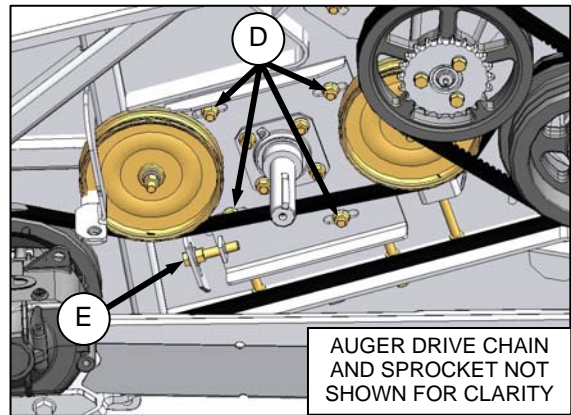

- Loosen the four nuts (D).
- Loosen jam nut on adjuster bolt (E), and turn bolt (E) to adjust auger fore-aft position.
- Tighten jam nut on bolt (E), and tighten nuts (D).
- Tighten auger drive chain as follows:
 - Turn adjuster bolt (C) to tighten chain (A). Deflection at (A) should be 1/4 in. (6 mm).
 - Tighten jam nut on bolt (C).
- Check auger drive V-belt (F) tension. Each belt should deflect 3/16 in. (4 mm) at mid-span when a load of 8-12 lbf (35-40 N) is applied to each belt. If necessary, adjust as follows:
 - Loosen jam nut on adjuster bolt (G).
 - Turn adjuster bolt (G) to achieve tension as per above.
 - Tighten jam nut at (G).
- Tighten bolts (B).

(continued next page)

SECTION 6 OPERATION

- i. Open RH endshield.
- j. Loosen reel drive belts as follows:

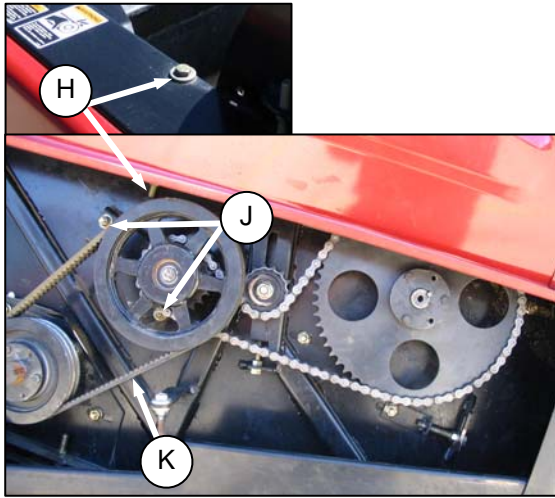

1. Loosen jam nut on adjuster bolt (H) and nuts (J).
2. Turn adjuster bolt (H) to loosen reel drive belts (K).

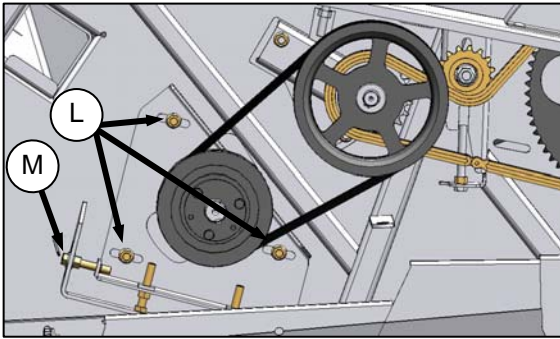

- k. Loosen three bolts (L).
- l. Loosen jam nut on adjuster bolt (M), and turn bolt (M) to adjust auger fore-aft position.
- m. Tighten jam nut and bolts (L).
- n. Tighten belts as follows:
 1. Turn adjuster bolt (H) to move pulley so that each belt (K) deflects 3/16 in. (4 mm) when a load of 8–12 lbf (35–40 N) is applied to each belt at mid-span.
 2. Tighten jam nut on adjuster bolt (H) and nuts (J).

- o. Check reel drive chain tension. Total chain slack at (N) should be 1/4 in. (6 mm). If necessary, adjust as follows:

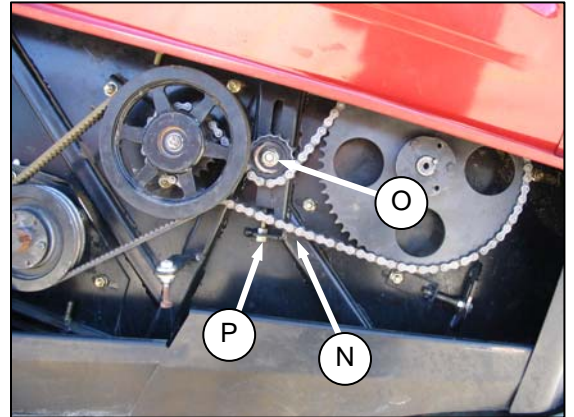

1. Loosen bolt (O) on sprocket, and jam nut on adjuster bolt (P).
 2. Turn adjuster bolt (P) to move idler sprocket downward until chain slack is achieved as above.
 3. Rotate auger and check chain for slack at tightest point. Re-adjust position of idler sprocket to achieve required slack.
 4. Tighten jam nut at (P) and nut (O) on sprocket. Re-check tension.
- p. Close shields before engaging header.

SECTION 6 OPERATION

6.17.4.2 Auger Vertical Adjustment: A30-S



CAUTION

To prevent accidental movement of windrower, place all controls in **NEUTRAL** or in **PARK**, engage park brake (if applicable), shut down engine, and remove key.

- Open LH endshield.
- Loosen auger drive chain (A) as follows:

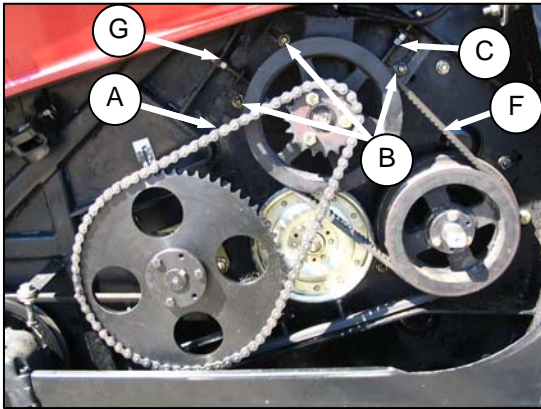

- Loosen three bolts (B).
- Loosen jam nut on adjuster bolt (C), and turn adjuster bolt (C) to loosen chain (A).

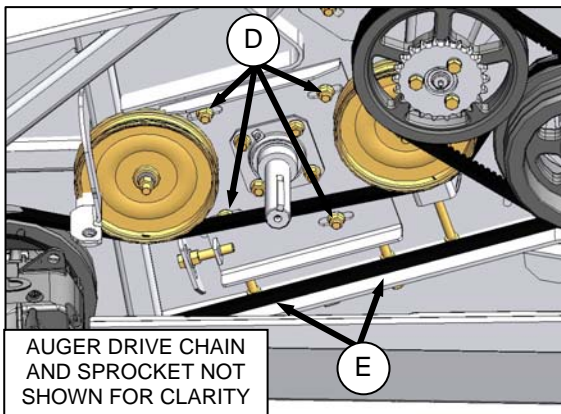

- Loosen four nuts (D).
- Loosen jam nuts on adjuster bolts (E), and turn bolts (E) to adjust auger vertical position.
- Tighten jam nuts and nuts (D).
- Tighten auger drive chain (A) as follows:
 - Turn adjuster bolt (C) to tighten chain (A). Deflection at (A) should be 1/4 in. (6 mm).
 - Tighten jam nut on bolt (C).

- Check auger drive V-belt (F) tension. Each belt should deflect 3/16 in. (4 mm) at mid-span when a load of 8–12 lbf (35–40 N) is applied to each belt. If necessary, adjust as follows:
 - Loosen jam nut on adjuster bolt (G).
 - Turn adjuster bolt (G) to achieve tension as per above.
 - Tighten jam nut at (G), and tighten bolts (B).
- Open RH endshield.
- Loosen reel drive belts (K) as follows:

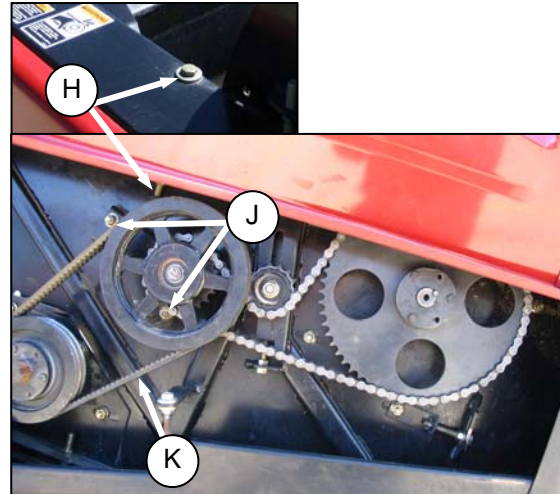

- Loosen jam nut on adjuster bolt (H) and nuts (J).
- Turn adjuster bolt (H) to loosen reel drive belts (K).

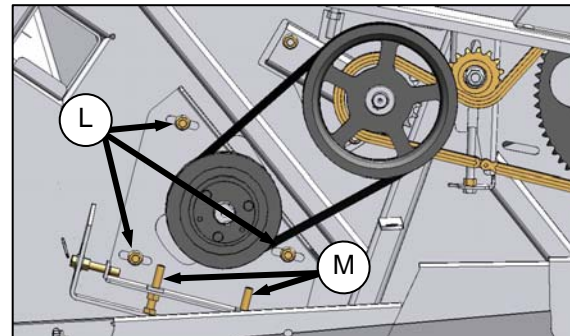

- Loosen three nuts (L).
- Loosen jam nuts on adjuster bolts (M), and turn bolt (M) to adjust auger vertical position.
- Tighten jam nuts and nuts (L).
- Tighten belts (K) as follows:
 - Turn adjuster bolt (H) to move pulley so that each belt (K) deflects 3/16 in. (4 mm) when a load of 8–12 lbf (35–40 N) is applied to each belt at mid-span.
 - Tighten jam nut on adjuster bolt (H) and nuts (J).

(continued next page)

SECTION 6 OPERATION

- n. Check reel drive chain tension. Total chain slack at (N) should be 1/4 in. (6 mm). If necessary, adjust as follows:

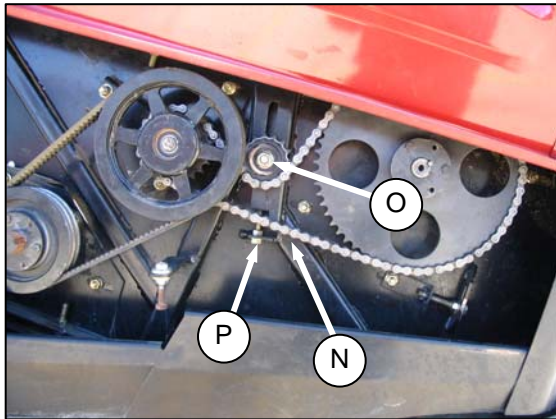

1. Loosen bolt (O) on sprocket, and jam nut on adjuster bolt (P).
 2. Turn adjuster bolt (P) to move idler sprocket downward until chain slack is achieved as above.
 3. Rotate auger and check chain for slack at tightest point. Re-adjust position of idler sprocket to achieve required slack.
 4. Tighten jam nut at (P) and nut (O) on sprocket. Re-check tension.
- o. Close shields before engaging header.

SECTION 6 OPERATION

6.17.4.3 Auger Fore-Aft Adjustment: A30-D



CAUTION

To prevent accidental movement of windrower, place all controls in **NEUTRAL** or in **PARK**, engage park brake (if applicable), shut off engine, and remove key.

- Open LH endshield.
- Loosen auger drive chain (A) as follows:

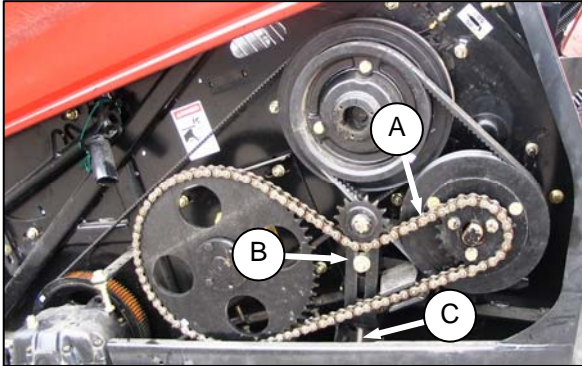

- Loosen nut (B) on idler sprocket support.
- Turn adjuster bolt (C) to loosen chain (A).

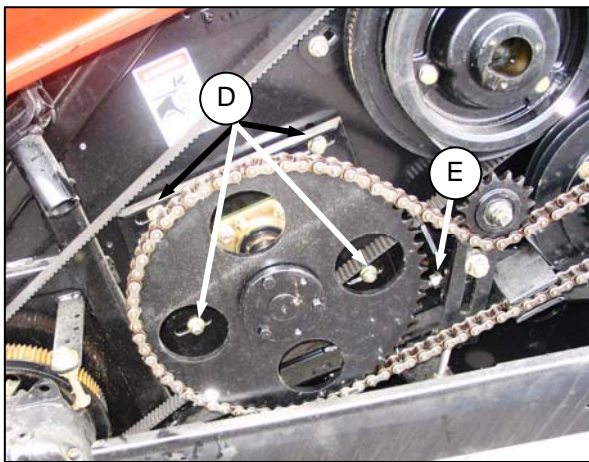

- Loosen four nuts (D).
- Loosen jam nut on adjuster bolt (E), and turn adjuster bolt (E) to adjust auger fore-aft position.
- Tighten jam nut and four nuts (D).
- Tighten auger drive chain (A) as follows:
 - Turn adjuster bolt (C) to achieve 1/4 in. (6 mm) slack at mid-span of chain (A).
 - Tighten nut (B) on idler sprocket support.
 - Rotate auger, and check chain for slack at tightest point. Re-adjust position of idler sprocket to achieve required slack.

- Open RH endshield.
- Loosen reel drive belts (F) as follows:

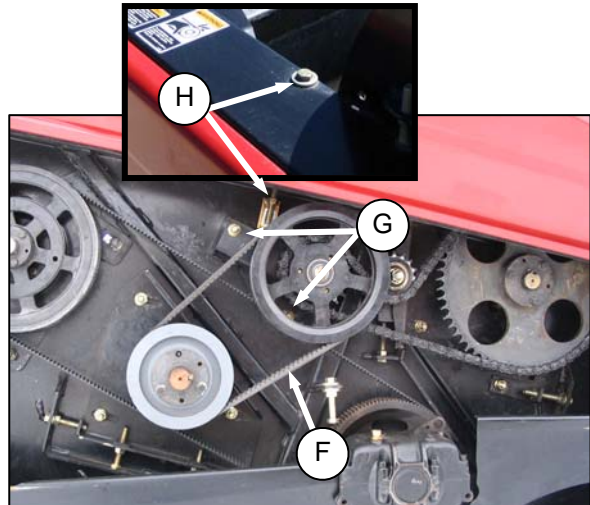

- Loosen nuts (G).
- Loosen jam nut on adjuster bolt (H), and turn adjuster bolt (H) to loosen reel drive belts.

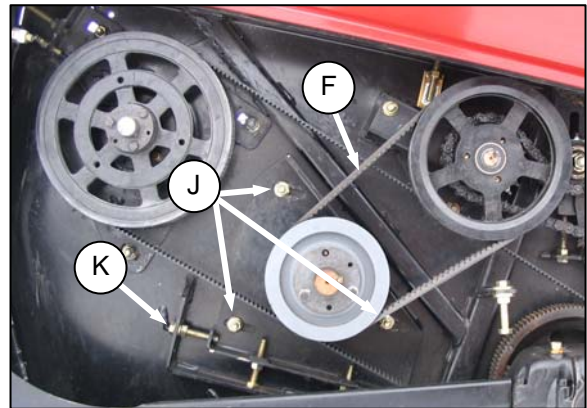

- Loosen nuts (J).
- Loosen jam nut on adjuster bolt (K), and turn adjuster bolt (K) to adjust auger fore-aft position.
- Tighten nuts (J), and jam nut.

(continued next page)

SECTION 6 OPERATION

- I. Check reel drive chain tension. Total chain slack at (K) should be 1/4 in. (6 mm). If necessary, adjust as follows:

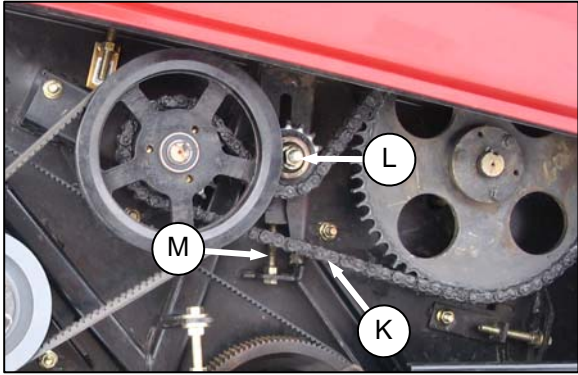

1. Loosen bolt (L) on sprocket and jam nut on adjuster bolt (M).
 2. Turn adjuster bolt (M) to move idler sprocket downward until chain slack is achieved as above.
 3. Rotate auger, and check chain for slack at tightest point. Re-adjust position of idler sprocket to achieve required slack.
 4. Tighten jam nut at (M) and nut (L) on sprocket. Re-check tension.
- m. Close shields before engaging header.

SECTION 6 OPERATION

6.17.4.4 Auger Vertical Adjustment: A30-D



CAUTION

To prevent accidental movement of windrower, place all controls in **NEUTRAL** or in **PARK**, engage park brake (if applicable), shut off engine, and remove key.

- Open LH endshield.
- Loosen auger drive chain (A) as follows:

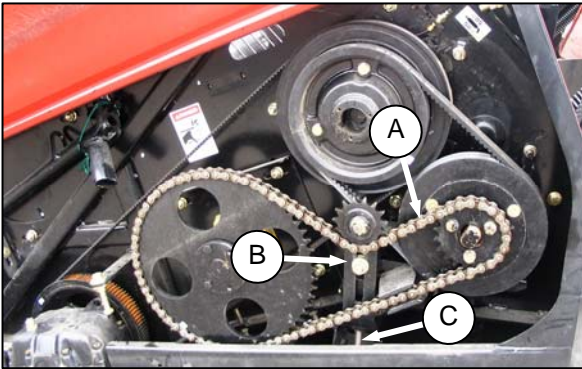

- Loosen nut (B) on idler sprocket support.
- Turn adjuster bolt (C) to loosen chain (A).

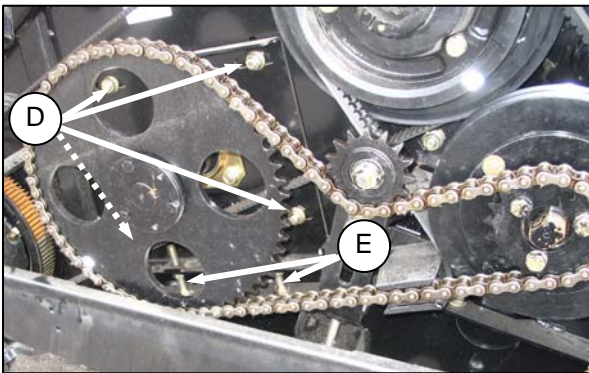

- Loosen four nuts (D).
- Loosen jam nut on the two adjuster bolts (E), and turn the two adjuster bolts (E) to adjust auger vertical position.
- Tighten jam nut and four nuts (D).
- Tighten auger drive chain (A) as follows:
 - Turn adjuster bolt (C) to achieve 1/4 in. (6 mm) slack at mid-span of chain (A).
 - Tighten nut (B) on idler sprocket support.
 - Rotate auger, and check chain for slack at tightest point. Re-adjust position of idler sprocket to achieve required slack.

- Open RH endshield.
- Loosen reel drive belts (E) as follows:

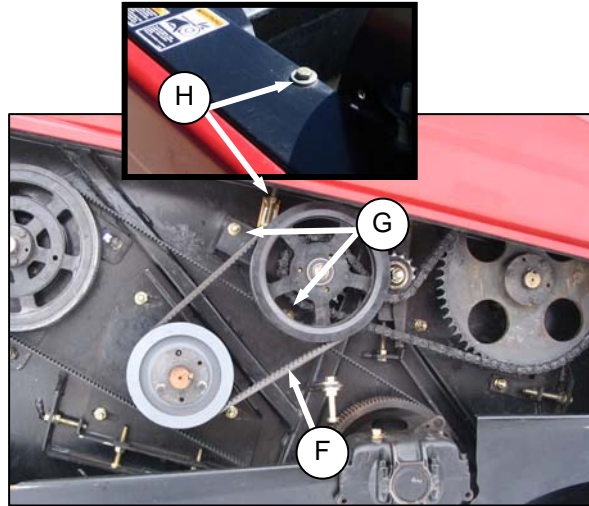

- Loosen nuts (G).
- Loosen jam nut on adjuster bolt (H), and turn adjuster bolt (H) to loosen reel drive belts (F).

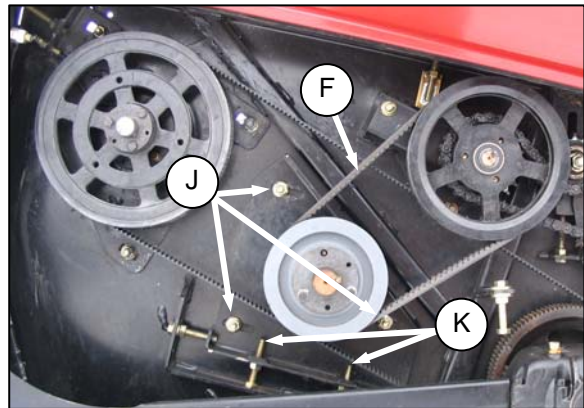

- Loosen nuts (J).
- Loosen jam nuts on the two adjuster bolts (K), and turn the two adjuster bolts (K) to adjust auger vertical position.
- Tighten nuts (J), and jam nuts.

(continued next page)

SECTION 6 OPERATION

- I. Check reel drive chain tension. Total chain slack at (K) should be 1/4 in. (6 mm). If necessary, adjust as follows:

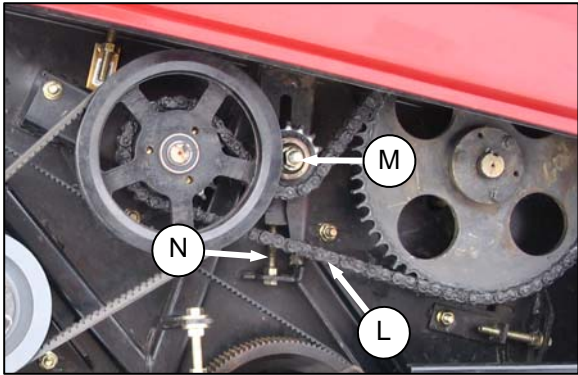

1. Loosen bolt (M) on sprocket and jam nut on adjuster bolt (N).
 2. Turn adjuster bolt (N) to move idler sprocket downward until chain slack is achieved as above.
 3. Rotate auger, and check chain for slack at tightest point. Re-adjust position of idler sprocket to achieve required slack.
 4. Tighten jam nut at (N) and bolt (M) on sprocket. Re-check tension.
- m. Close shields before engaging header.

SECTION 6 OPERATION

6.17.4.5 Auger Fore-Aft Adjustment: A40-D



CAUTION

To prevent accidental movement of windrower, place all controls in **NEUTRAL** or in **PARK**, engage park brake (if applicable), shut off engine, and remove key.

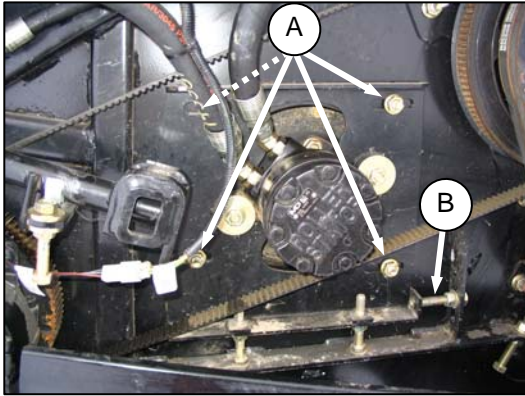

- Open LH endshield.
- Loosen four nuts (A).
- Loosen jam nut on adjuster bolt (B), and turn bolt (B) to adjust auger fore-aft position.
- Tighten jam nut.
- Tighten nuts (A).
- Open RH endshield.

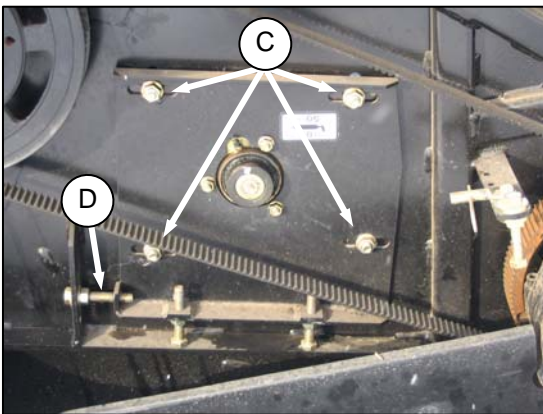

- Loosen four nuts (C).
- Loosen jam nut on adjuster bolt (D), and turn bolt (D) to adjust auger fore-aft position.
- Tighten jam nut.
- Tighten nuts (C).
- Close shields before engaging header.

6.17.4.6 Auger Vertical Adjustment: A40-D

- Open LH endshield.

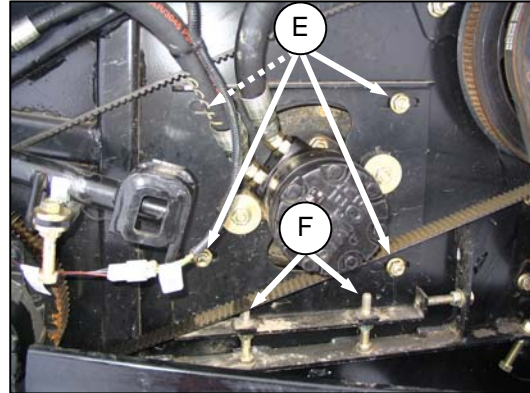

- Loosen four nuts (E).
- Loosen jam nuts on adjuster bolts (F), and turn bolts (F) to adjust auger vertical position.
- Tighten jam nuts.
- Tighten nuts (E).
- Open RH endshield.

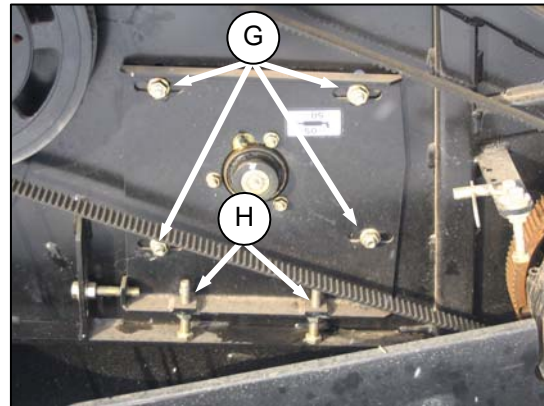

- Loosen four nuts (G).
- Loosen jam nuts on adjuster bolts (H), and turn bolts (H) to adjust auger vertical position.
- Tighten jam nuts.
- Tighten nuts (G).
- Close shields before engaging header.

SECTION 6 OPERATION

6.17.5 Reel Position

Reel position has been found to be a critical factor in achieving good results in adverse conditions. Reel position is factory-set for average straight standing crop. It can be adjusted both vertically and horizontally (fore-aft) for different crop conditions.

See table below for recommended reel position in unusual crop conditions:

CROP CONDITION	REEL POSITION
Crop Down or Lodged	Forward and Down (Also Increase Reel Speed)
Wet or Dead Material Collects On Cutterbar and Plugs Sickle.	Back and Down (Close To Guards)
Short Crop	Back
Thick Stemmed Or Heavy Standing	Up And Forward

To make adjustments to reel position, refer to the following Sections 6.17.5.1 to 6.17.5.4.

6.17.5.1 Reel Fore-Aft Position: A30-S, A30-D

NOTE

The reel must be adjusted equally on both sides.



CAUTION

To prevent accidental movement of windrower, place all controls in **NEUTRAL** or in **PARK**, engage park brake (if applicable), shut off engine, and remove key.

- a. Open LH endshield.

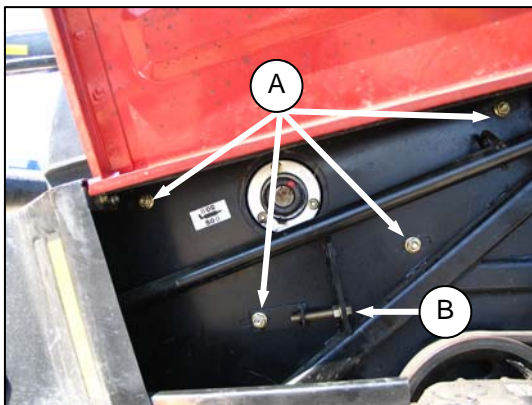

- b. Loosen four nuts (A).
- c. Loosen jam nut on adjuster bolt (B), and turn bolt (B) to adjust fore-aft position.
- d. Tighten jam nut, and four nuts (A).

- e. Open RH endshield.
- f. Loosen the reel drive chain (C) as follows:

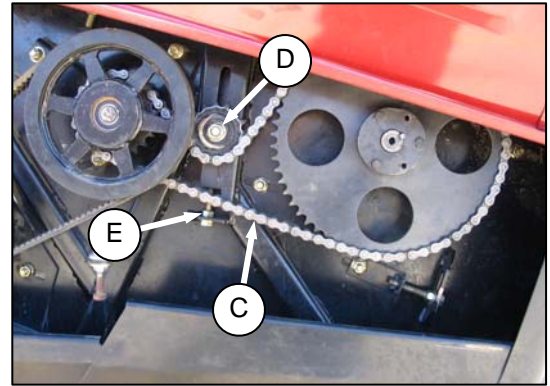

1. Loosen nut (D) on sprocket.
2. Loosen jam nut on adjuster bolt (E), and turn adjuster bolt (E) to loosen chain.

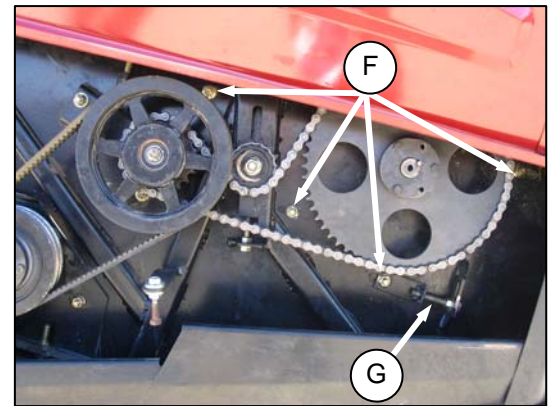

- g. Loosen four nuts (F).
- h. Loosen jam nut on adjuster bolt (G), and turn adjuster bolt to adjust reel fore-aft position.
- i. Tighten jam nut, and four nuts (F).
- j. Tighten reel drive chain (C) as follows:
 1. Turn adjuster bolt (E) to tighten chain until total chain slack at (C) is 1/4 in. (6 mm).
 2. Tighten jam nut at (E) and nut (D) and re-check tension.
- k. Close shields before engaging the header.

SECTION 6 OPERATION

6.17.5.2 Reel Vertical Position: A30-S, A30-D



CAUTION

To prevent accidental movement of windrower, place all controls in **NEUTRAL** or in **PARK**, engage park brake (if applicable), shut off engine, and remove key.

- a. Open LH endshield.

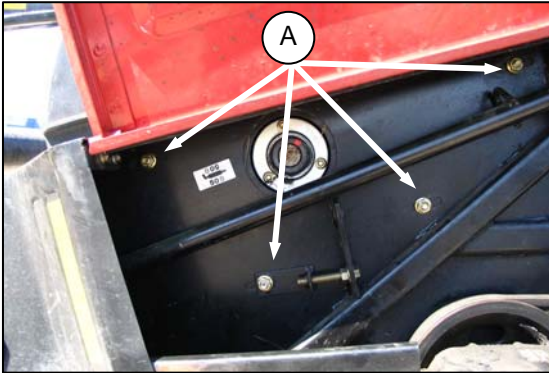

- b. Loosen four nuts (A).

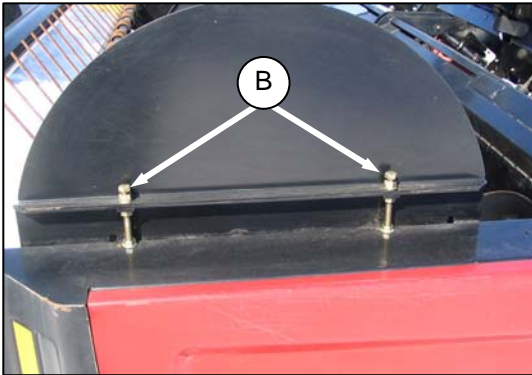

- c. Loosen jam nuts on adjuster bolts (B), and turn bolts (B) to raise or lower reel.

NOTE

Adjustment at forward adjuster bolt should be 0.47 in. (12 mm) lower than at rear adjuster bolt.

- d. Tighten jam nuts, and nuts (A).

- e. Open RH endshield.

- f. Loosen reel drive chain (C) as follows:

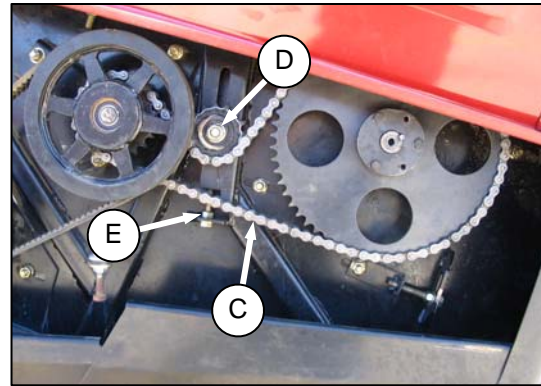

1. Loosen nut (D) on sprocket.
2. Loosen jam nut on adjuster bolt (E), and turn adjuster bolt (E) to loosen chain.

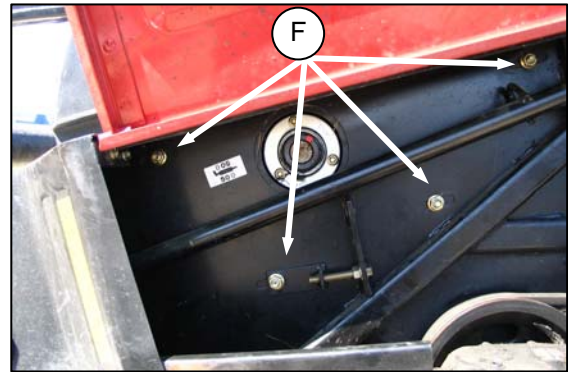

- g. Loosen four nuts (F).

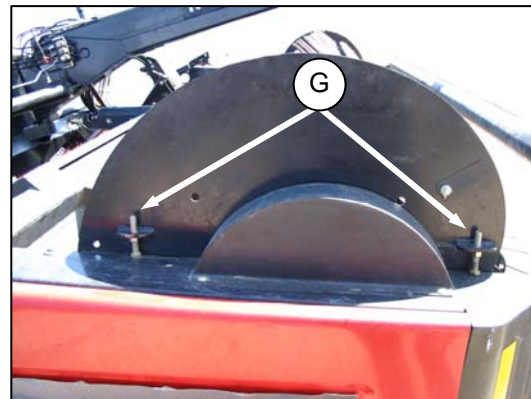

- h. Loosen jam nuts on adjuster bolts (G), and turn adjuster bolts to raise or lower reel.

NOTE

Adjustment at forward adjuster bolt should be 0.47 in. (12 mm) lower than at rear adjuster bolt.

- i. Tighten jam nuts, and four nuts (F).

(continued next page)

SECTION 6 OPERATION

- j. Tighten reel drive chain (C) as follows:

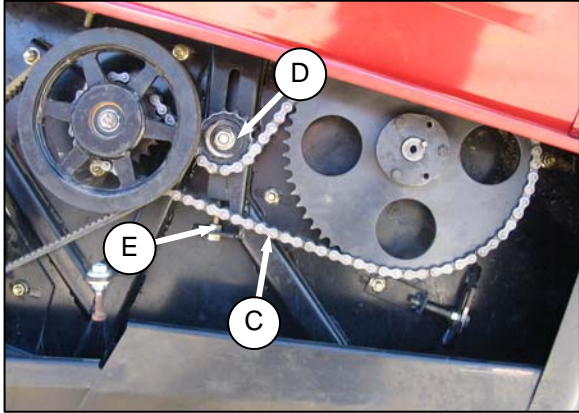

1. Turn adjuster bolt (E) to tighten chain until total chain slack at (C) is 1/4 in. (6 mm).
2. Tighten jam nut at (E) and nut (D) and re-check tension.

- k. Close shields before engaging header.

- l. Check that reel rotates freely.

IMPORTANT

Manually rotate reel, and ensure that tines do not contact header pan, otherwise damage to pan will result.

If necessary, grind off excessive length from tine if tine length varies considerably. Remove any sharp edges or burrs from tine.

- m. Check that reel is evenly adjusted.

6.17.5.3 Reel Fore-Aft Position: A40-D

NOTE

The reel must be adjusted equally on both sides.



CAUTION

To prevent accidental movement of windrower, place all controls in **NEUTRAL** or in **PARK**, engage park brake (if applicable), shut off engine, and remove key.

- a. Open LH endshield.

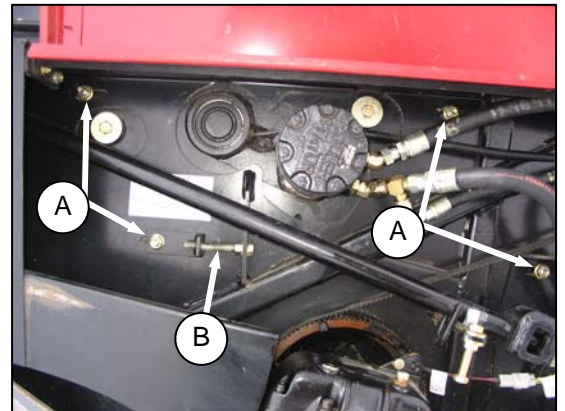

- b. Loosen four nuts (A).
- c. Loosen jam nut on adjuster bolt (B), and turn bolt (B) to adjust reel fore-aft position.
- d. Tighten jam nut.
- e. Tighten four nuts (A).
- f. Open RH endshield.

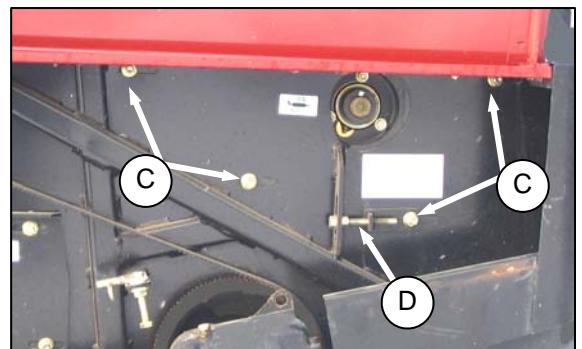

- g. Loosen four nuts (C).
- h. Loosen jam nut on adjuster bolt (D), and turn bolt (D) to adjust reel fore-aft position.
- i. Tighten jam nut.
- j. Tighten four nuts (C).
- k. Close driveshields before engaging header.

SECTION 6 OPERATION

6.17.5.4 Reel Vertical Position: A40-D

- a. Open LH endshield.

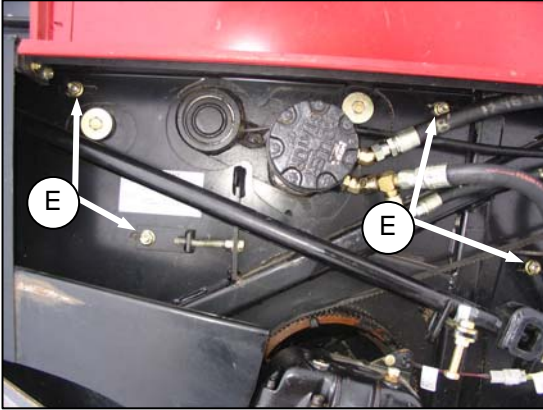

- b. Loosen four nuts (E).

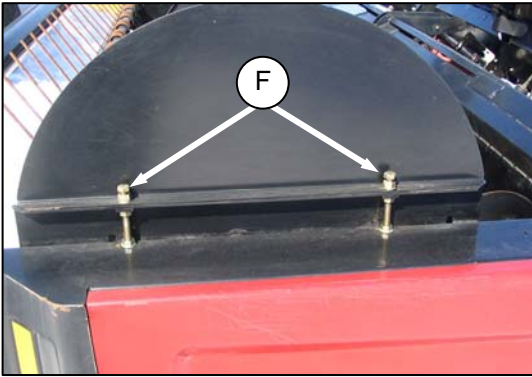

- c. Loosen jam nuts on adjuster bolts (F), and turn bolts (F) to raise or lower reel.

NOTE

Adjustment at forward adjuster bolt should be 0.47 in. (12 mm) lower than at rear adjuster bolt.

- d. Tighten jam nuts.
e. Tighten four nuts (E).

- f. Open RH endshield.

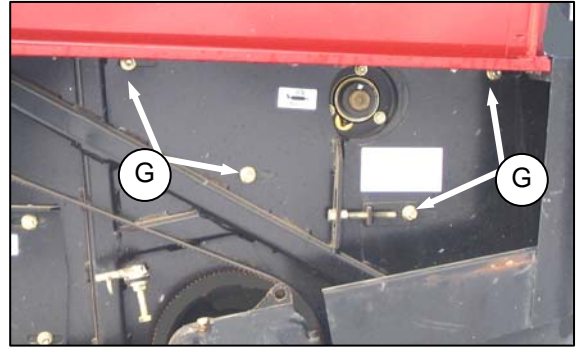

- g. Loosen four nuts (G).

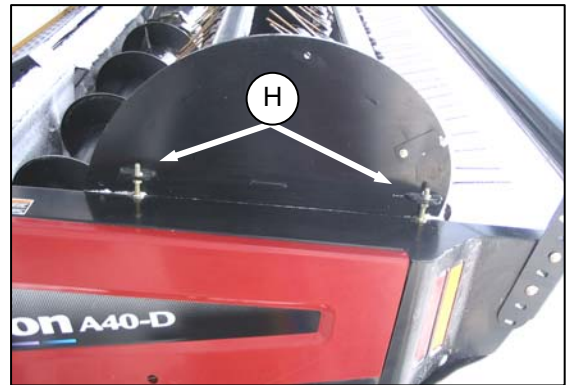

- h. Loosen jam nuts on adjuster bolts (H), and turn bolts (H) to adjust reel vertical position.
i. Tighten jam nut.
j. Tighten four nuts (G).
k. Close shields before engaging header.
l. Check that the reel rotates freely.

IMPORTANT

Manually rotate reel, and ensure that tines do not contact header pan, otherwise damage to pan will result.

If necessary, grind off excessive length from tine if tine length varies considerably. Remove any sharp edges or burrs from tine.

- m. Check that reel is evenly adjusted.

SECTION 6 OPERATION

6.17.6 Tine Aggressiveness Adjustment



CAUTION

To prevent accidental movement of windrower, place all controls in NEUTRAL or in PARK, engage park brake (if applicable), shut off engine, and remove key.

- a. Open RH endshield.

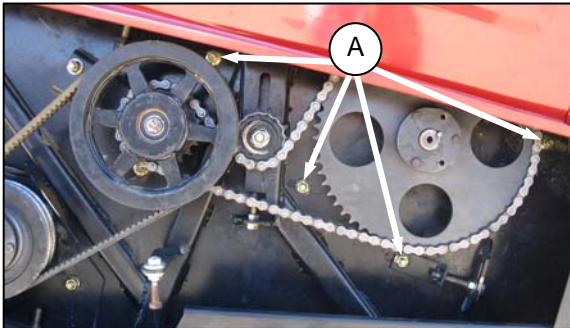

A30-S and A30-D



A40-D

- b. At right side of reel (cam end) only, loosen four nuts (A).

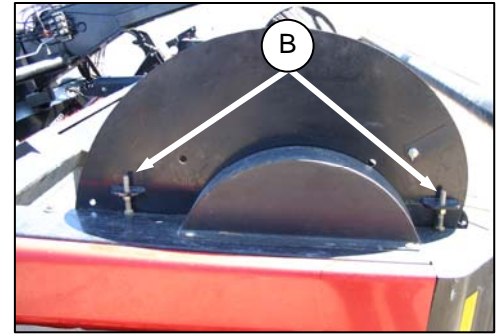

A30-S and A30-D

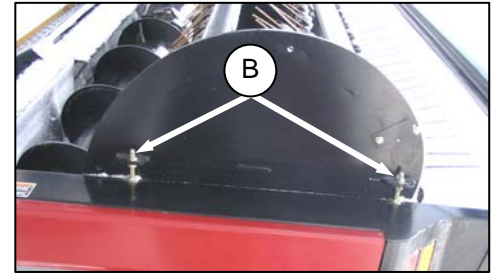

A40-D

- c. Loosen jam nuts on bolts (B), and turn bolts to rotate cam to desired position. Viewed from right side, rotate cam clockwise to obtain more aggressive tine action.
- d. Tighten nuts (A), and jam nuts on bolts (B).
- e. Check that chain and/or belt have not become over-tight. Adjust to recommended tension if required. Refer to Sections 7.9.1 *Reel Drive Chain: A30-S, A30-D*, and 7.9.2 *Reel Drive Belts: A30-S, A30-D*.
- f. Check reel tine to header pan clearance to ensure that there is no contact between reel tines and the header pan. Refer to the next section.

SECTION 6 OPERATION

6.17.7 Reel Tine to Header Pan Clearance

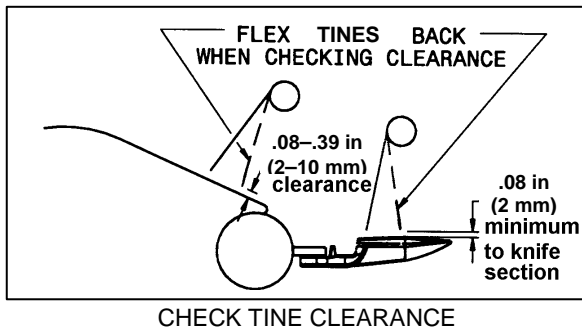

IMPORTANT

The above dimensions are provided as guidelines only. Tines may slightly contact the guards but not the knife sections or the auger pan.

- Rotate reel slowly by hand, and check tine clearance at knife and pan. **Flex tines to simulate crop-loaded position to ensure tine clearances to knife sections and auger pan are adequate for working conditions.**
- Check that reel rotates freely.

IMPORTANT

If there are a few reel tine fingers that are touching the pan while the rest are at the correct height, trim the longer tines to match the rest. Be sure to adjust both sides of the reel. Ensure that tines do not contact the plastic header pan.

6.17.8 Cutting Height

Cutting height is controlled with a combination of skid shoes or gauge rollers, and header angle adjustment - not with the header lift cylinders. Having the header ride on the skid shoes allows the float linkage to float header over obstacles, and follow ground contours, rather than supporting header with the cylinder.

NOTE

Lowering the skid shoes or gauge rollers raises the cutting height. This may be desirable in stony conditions, to reduce damage to cutting components. Also, a longer stubble length helps material dry faster.



WARNING

To avoid bodily injury or death from unexpected start-up or fall of raised machine, stop engine, remove key, and engage lift cylinder lockout valves before going under machine to adjust skid shoes or for any reason.

6.17.8.1 Cutting Height Adjustment:

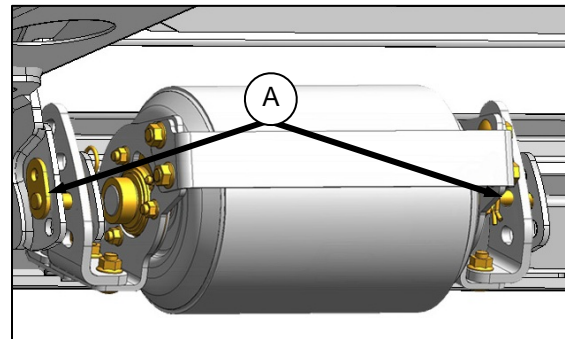
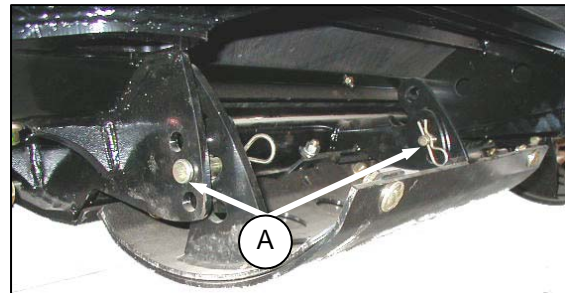

- Raise header, and engage lift cylinder lockouts.
- Remove pins (A) at each skid shoe or gauge roller.
- Raise or lower skid shoe or gauge roller to desired position.
- Replace pins (A).
- Check that skid shoes or gauge rollers are adjusted to the same position.
- Check header float, and adjust if required. Refer to Section 6.17.10 *Header Flotation*.

NOTE

LH and RH skid shoes are standard equipment. Two more inner skid shoes may be added if required. A set of two gauge rollers may be installed in place of the outer skid shoes.

SECTION 6 OPERATION

6.17.9 Header Angle

Header (or guard) angle can be varied from 8° to 16° below horizontal. Choose an angle that maximizes performance for your crop and field conditions.

A flatter angle provides better clearance in stony conditions while a steeper angle is required in down crops for better lifting action.

6.17.9.1 Header Angle: Self-Propelled

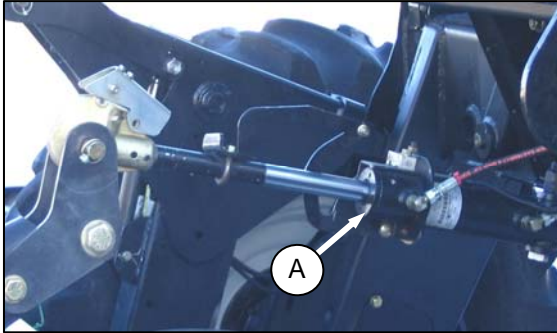

Header angle can be hydraulically adjusted from the cab using hydraulic cylinder (A), without shutting down the windrower. To adjust angle, refer to your Self-Propelled Windrower Operator's Manual.

6.17.9.2 Header Angle: Pull-Type

6.17.9.2.1 Mechanical Adjustment (if equipped)

- Lower header so that cutter bar is resting on the ground.

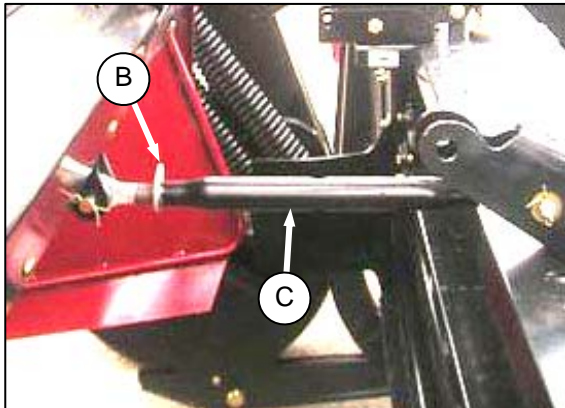

- Loosen nut (B).
- To decrease (flatten) header angle**, rotate the turnbuckle sleeve (C) so that the turnbuckle decreases in length.
- To increase (steepen) header angle**, rotate the turnbuckle sleeve (C) so that the turnbuckle increases in length.

- Snug up nut (B), but do not over-tighten. A slight tap with a small hammer is sufficient.
- Check cutting height, and adjust if required. Refer to Section 6.17.8 *Cutting Height*.
- Check header float, and adjust if required. Refer to Section 6.17.10 *Header Flotation*.

6.17.9.2.2 Hydraulic Adjustment (if equipped)

The header angle can be adjusted from the tractor, without shutting down the windrower/mower conditioner.

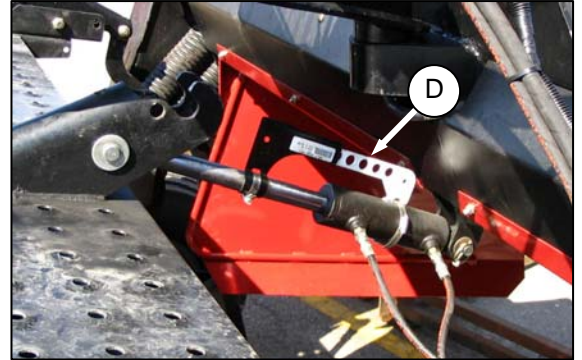

- To decrease (flatten) header angle**, operate tractor hydraulic control so that cylinder retracts, decreasing the number of holes in the gauge (D) that are exposed.
- To increase (steepen) header angle**, operate tractor hydraulic control so that cylinder extends, increasing the number of holes in the gauge that are exposed.

SECTION 6 OPERATION

6.17.10 Header Flotation

Header flotation springs are normally set so 70 lbf (311 N) is required to lift either end of the header just off the ground. In rough or stony conditions, it may be desirable to change setting to 35–50 lbf (156–222 N) to protect cutting components.

NOTE

When float setting is light, it may be necessary to use a slower ground speed to avoid excessive bouncing, and leaving a ragged cut.

6.17.10.1 Flotation Adjustment: Self-Propelled

Header float can be hydraulically adjusted from the cab, without shutting down the windrower. To adjust float, refer to your Self-Propelled Windrower Operator's Manual.

6.17.10.2 Flotation Adjustment: Pull-Type

IMPORTANT

Float setting (or lifting force) **must be equal** on both ends of the header. LH and right ends require different spring lengths to achieve equal float at both ends.

IMPORTANT

Because header weight transfers to outside tire whenever header is swung from one side to the other, tires must be fully inflated (30 psi [207 kPa]) to minimize effects on header float.



CAUTION

To prevent accidental movement of windrower, place all controls in NEUTRAL or in PARK, engage park brake (if applicable), shut off engine, and remove key.

- Position header directly behind tractor, and raise header fully.
- Stop engine, remove key and engage lift cylinder lockouts.

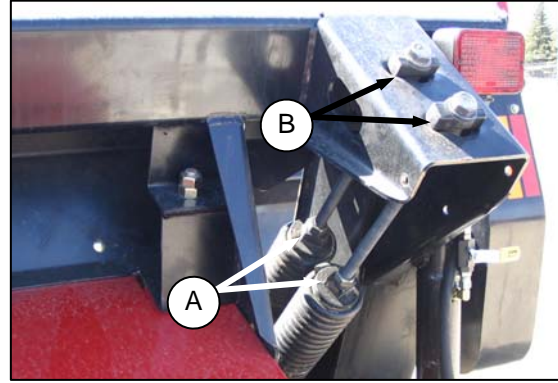

- Back jam nuts (A) away from spring.
- To increase flotation**, turn adjuster bolts (B) clockwise (further into spring).

To decrease flotation, turn adjuster bolts (B) counterclockwise.

NOTE

Springs must be adjusted in pairs.

- Tighten jam nuts (A) against spring inserts to secure the setting.
- Lower header, and check header flotation at each end.

NOTE

Other operating variable adjustments may affect float setting. Check the float, and re-adjust if necessary after adjusting reel position, cutting height, or header angle.

Also, if using a tractor with drawbar height different than 16 in. (406 mm) flotation will be affected. Adjust as required.

SECTION 6 OPERATION

6.17.11 Feed Pan / Rock-Drop Tine Position

The rear of the feed pan is adjustable up and down to raise or lower the feed pan and rock drop tines.

- Lowering the feed-pan helps prevent plugging in heavy crop.
- Raising the feed-pan helps to form an even windrow in light crop.



WARNING

To avoid bodily injury or death from unexpected start-up or fall of raised machine; stop engine, remove key and engage header lift cylinder stops before going under machine.

- a. Raise header fully, and engage header lift cylinder stops.
- b. Stop engine, and remove key.

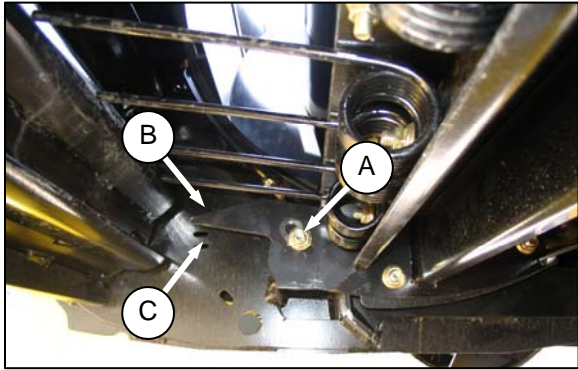

- c. Loosen nut (A) both sides, and align pointer (B) at each side of rock drop tine support with one of the slots (C) to match crop condition.

CROP CONDITION	LIGHT	NORMAL	HEAVY
SLOT	Upper	Center	Lower

- d. Tighten hardware on both sides.
- e. Disengage header lift cylinder stops.

SECTION 6 OPERATION

6.17.12 Hay Conditioner

Steel rolls condition the crop by crimping and crushing the stem in several places to allow moisture release for quicker drying. The degree to which crop is conditioned as it passes through the rolls is controlled by roll gap (factory-set at 1/4 in. [6 mm]). See illustration below.

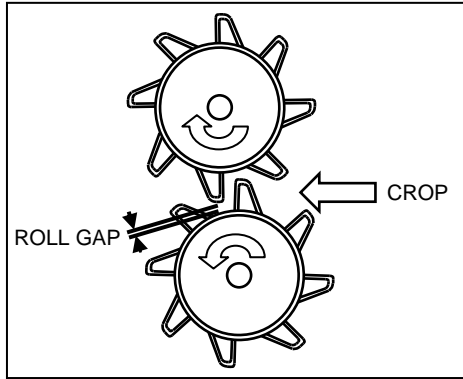

Correct conditioning of alfalfa, clover and other legumes is usually indicated when 90% of the stems show cracking, but no more than 5% of the leaves are damaged. Use only enough roll gap to achieve this result.

A larger gap (up to 1 in. [25 mm]) may be desirable in thick stemmed cane-type crops; however, too large a gap may cause feeding problems.

Grass type crops may require less gap for proper feeding and conditioning.

6.17.12.1 Roll Gap Adjustment



CAUTION

To prevent accidental movement of windrower, place all controls in **NEUTRAL** or in **PARK**, engage park brake (if applicable), shut off engine, and remove key.

- Lower header fully.
- Stop engine, and remove key.

NOTE

When adjusting roll gap, be sure that the decal reading is the same on both sides of the conditioner roll to achieve consistent intermesh across the rolls.

NOTE

Each division on the roll gap decal represents a change of approximately 1/8 in. (3mm) in roll gap. The factory-setting of 1/4 in. (6 mm) roll gap is mark 1 on the decal (C).

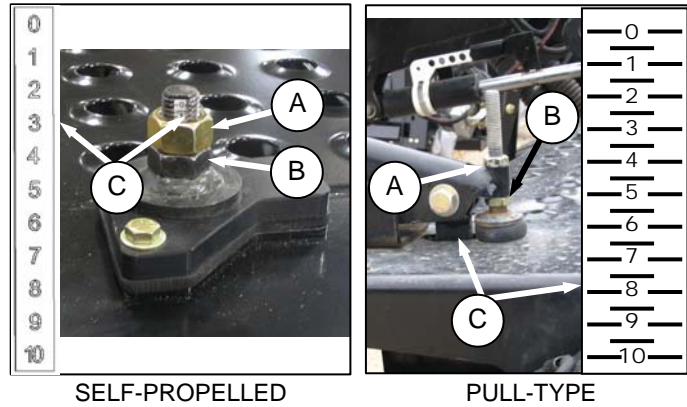

- Loosen and back-off upper jam nut (A), on both sides of conditioner.
- To **increase roll gap**, turn lower nut (B) to raise link, and increase the gauge (C) setting.
- To **decrease roll gap**, turn lower nut (B) to lower link, and decrease the gauge (C) setting.
- Tighten jam nuts (A), both sides.

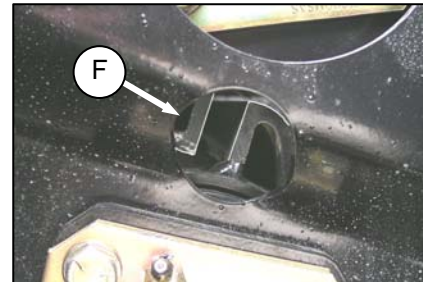
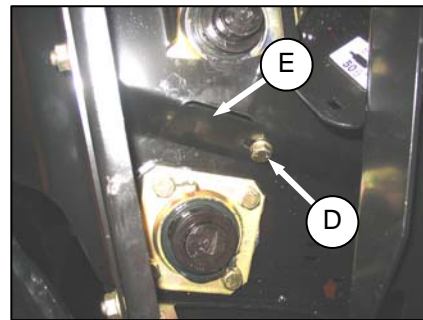

- Loosen bolt (D), and rotate cover (E) to expose access port (F).
- Inspect space between roll bars at both ends of the rolls at access port (F).

IMPORTANT

Roll timing and alignment are critical when the roll gap is decreased because:

- conditioning is affected, and
 - the bars **may** contact each other.
- Check roll timing and alignment when reducing roll gap. Refer to Section 6.17.12.2 Roll Timing and Alignment.
 - Close cover (E), and tighten bolt (D).

SECTION 6 OPERATION

6.17.12.2 Roll Timing and Alignment

For proper conditioning, the rolls must be properly timed and aligned, with each steel bar on one roll centered between two bars of the other roll as shown. The factory-setting should be suitable for most crop conditions.



WARNING

To avoid bodily injury or death from unexpected start-up or fall of raised machine; stop engine, remove key and engage lift cylinder stops before going under machine to examine roll timing, or for any reason.

6.17.12.2.1 Roll Timing

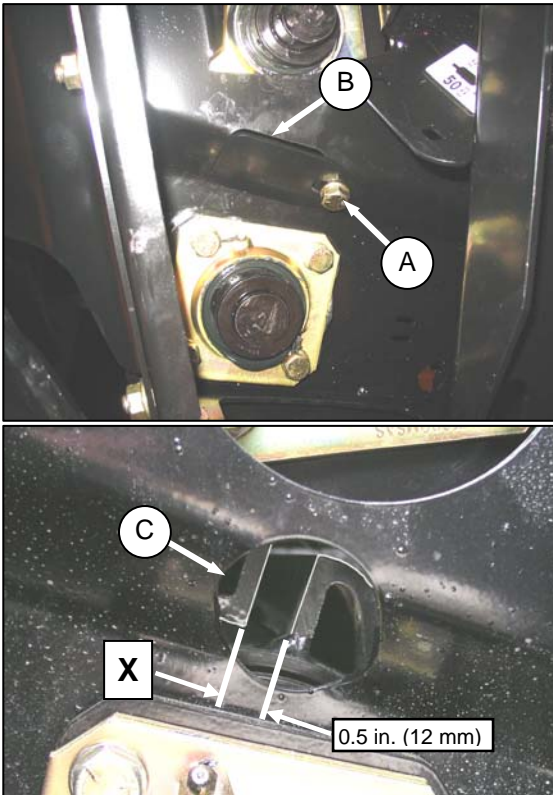

- Loosen bolt (A), and rotate cover (B) to expose access port (C) at each end of conditioner.
- Examine roll timing (distance 'X') at each end of the rolls with header fully lowered. Each steel bar on one roll should be centered between two bars of the other roll so that distance 'X' is 0.5 in. (12 mm).

NOTE

If the distance 'X' varies more than 1/16 in. (1.6 mm) from one end to the other, the rolls should be re-aligned. Refer to next Section 6.17.12.2.2 Roll Alignment.

- If required, adjust the roll timing as follows:

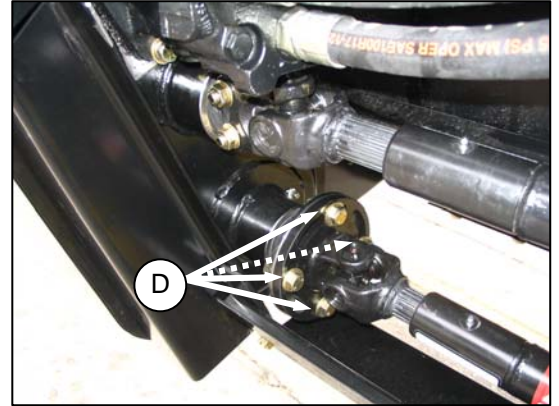

- Loosen four bolts (D) in slots of yoke plate on lower roll universal shaft.
- Turn rolls to achieve best timing.
- When roll timing is satisfactory, tighten bolts (D) to secure the position.
- Re-check distance between the bars at both ends of the rolls at (C).
- Close cover (B), and tighten bolt (A).

SECTION 6 OPERATION

6.17.12.2.2 Roll Alignment

The rolls can be aligned in the fore and aft direction by shimming the pivot assembly link at the RH end of the upper roll. Rolls are aligned at the factory, but adjustment is provided in case the rolls become misaligned during operation.



CAUTION

To prevent accidental movement of windrower, place all controls in NEUTRAL or in PARK, engage park brake (if applicable), shut off engine, and remove key.

- a. Lower header until it rests on the ground.

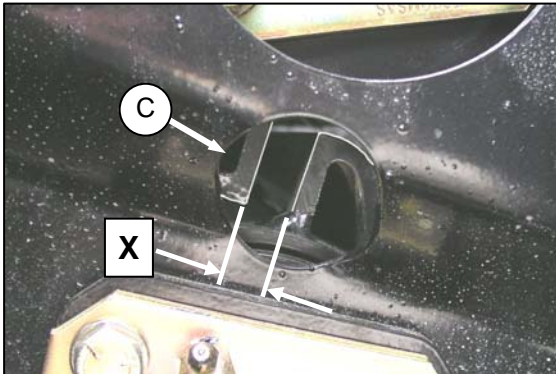
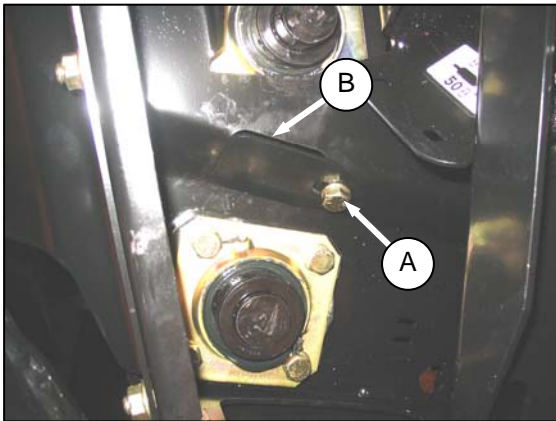

- b. Loosen bolt (A), and rotate cover (B) to expose access port (C).
- c. Examine roll timing (distance 'X') at each end of the rolls.

NOTE

The rolls are aligned if the distance 'X' varies less than 1/16 in. (1.6 mm) from one end to the other.

If 'X' varies more than 1/16 in. (1.6 mm), align rolls as follows:

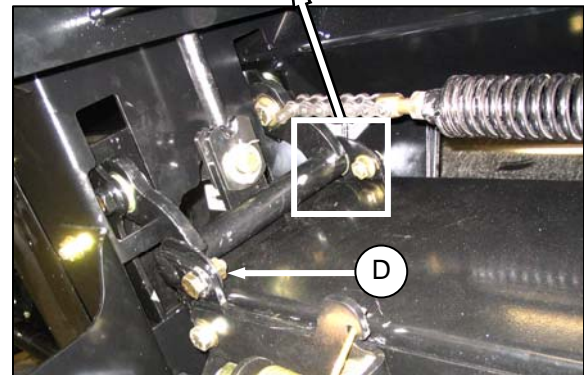
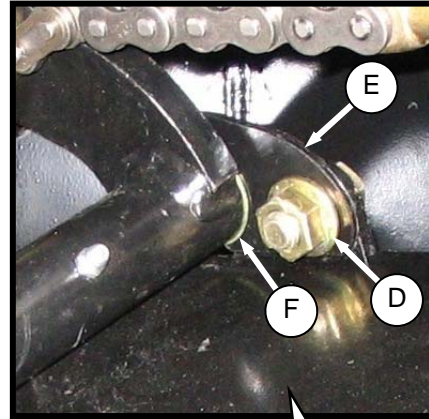

- d. Remove nuts and bolts (D), and remove shims (E). The shims can be lifted off the pivot rod.
- e. Move upper roll until dimension 'X' at both ends looking through (C) is within 1/16 in (1.6 mm).
- f. Re-install shims, ensuring hardened washer (F) is against the pivot tube.
- g. Re-install bolts (D) and nuts.
- h. Operate header / mower conditioner, and re-check alignment.
- i. Close cover (B), and tighten bolt (A).

SECTION 6 OPERATION

6.17.13 Roll Tension

The roll tension (the force holding the rolls together) is factory-set, and is adjustable. There is a spring (A) for each end of the roll. See illustration below.



CAUTION

To prevent accidental movement of windrower, place all controls in NEUTRAL or in PARK, engage park brake (if applicable), shut off engine, and remove key.

- a. Lower header fully.
- b. Stop engine, and remove key.

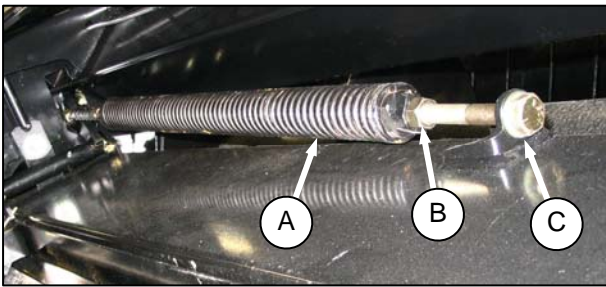

- c. **To increase the roll tension**, loosen jam nut (B) at spring insert, and turn spring draw-bolt (C) clockwise to tighten the spring. Tighten jam nut (B).
- d. **To decrease the roll tension**, loosen jam nut (B) at spring insert, and turn spring draw-bolt (C) counterclockwise to loosen the spring. Tighten jam nut (B).

SECTION 6 OPERATION

6.17.14 Forming Shields



WARNING

Keep hands and feet away from discharge opening. Keep everyone several hundred feet away from your operation. Never direct the discharge toward anyone. Stones or other foreign objects can be ejected with force.

Position of forming shields controls the width and placement of the windrow. The decision on forming shield position (settings between 36 in. and 92 in. [915 and 2346 mm]) should be made based on the following factors:

- weather conditions (rain, sun, humidity, wind),
- type and yield of crop,
- drying time available, and
- method of processing (green-feed, bales, silage).

A wider windrow will generally dry faster and more evenly, resulting in less protein loss. Fast drying is especially important in areas where the weather allows only a few days to cut and bale. Refer to Section 6.18 HAYING TIPS for more information.

Where weather conditions permit or when drying is not critical, for example, when cutting for silage or green-feed, a narrower windrow may be preferred for ease of pick-up.

6.17.14.1 Side Deflectors

The position of the side forming shields controls the width and placement of the windrow.



CAUTION

To prevent accidental movement of windrower, place all controls in **NEUTRAL** or in **PARK**, engage park brake (if applicable), shut off engine, and remove key.

To ensure windrow placement is centered with respect to carrier/drive wheels, adjust both side deflectors to the same hole position on the adjuster bar.

To achieve this setting, adjuster bars must be in the corresponding hole both sides.

- a. Set forming shield side deflectors to desired width by re-positioning adjuster bars as follows:

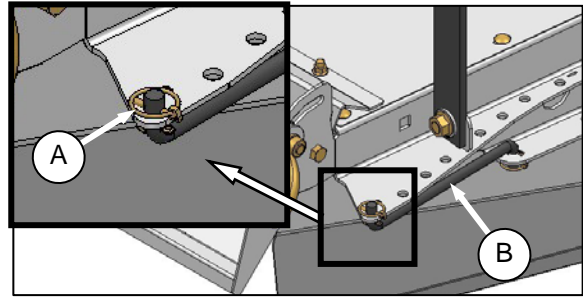

SELF-PROPELLED

1. For self-propelled machines, remove lynch pin (A), move adjuster bar (B) to another hole, and re-install lynch pin (A).

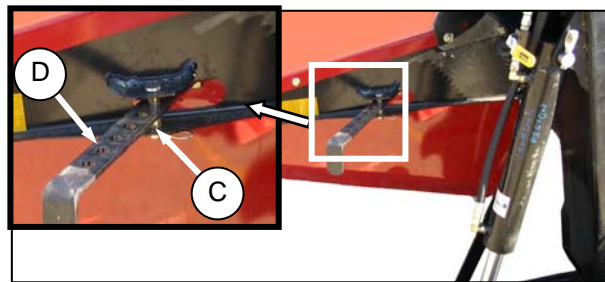

PULL-TYPE

2. For pull-type machines, remove hairpin and clevis pin (C). Move adjuster bar (D) to another hole, and re-install clevis pin (C) and hairpin.
- b. If forming shield attachment is too tight or too loose, adjust as follows:

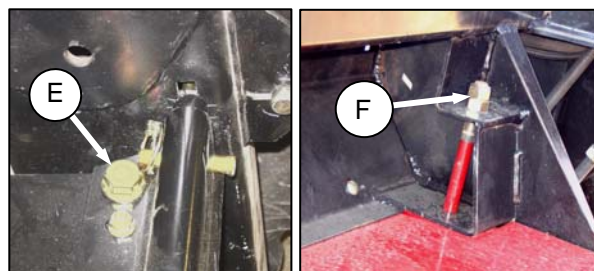

SELF-PROPELLED

PULL-TYPE

1. On self-propelled headers, tighten or loosen nut (E) as required.
2. On pull-type headers, back off top nut at (F), and adjust lower nut at (F) as required. Then, holding lower nut with a wrench, tighten top nut securely against lower nut.

SECTION 6 OPERATION

6.17.14.2 Rear Deflector (Fluffer Shield)

The rear deflector (G) slows the crop exiting the conditioner rolls, directs the flow downward, and fluffs the material.



CAUTION

To prevent accidental movement of windrower, place all controls in **NEUTRAL** or in **PARK**, engage park brake (if applicable), shut off engine, and remove key.

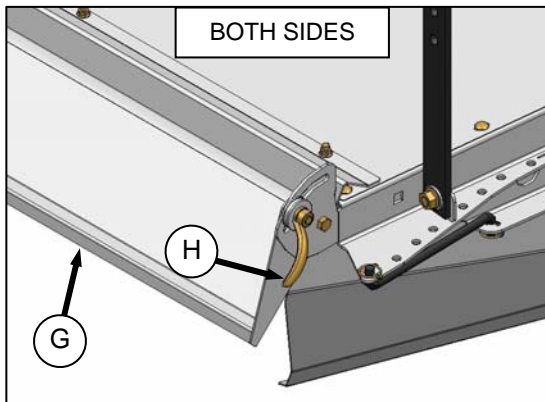

SELF-PROPELLED

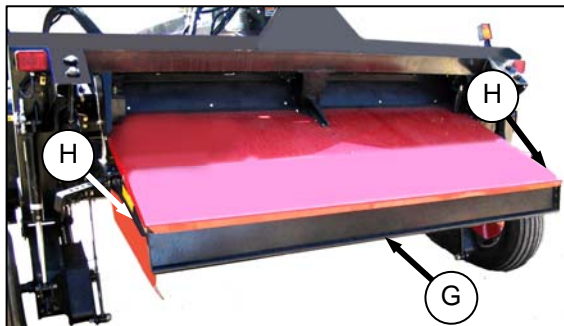

PULL-TYPE

- For more crop control in light material, lower the deflector (G) by pushing down on one side of the deflector, and then on the other side. Locking handles (H) are located at either end of deflector, and may be loosened slightly.
- For heavier crops, raise the deflector (G) by pulling up on one side, and then on the other side.

NOTE

For even windrow formation, be sure the deflector is not twisted.

SECTION 6 OPERATION

6.17.15 Tall Crop Dividers

The tall crop dividers attach to the ends of the header for clean crop dividing, and reel entry in tall crops.

They can be easily adjusted to suit the crop, or removed when not required.

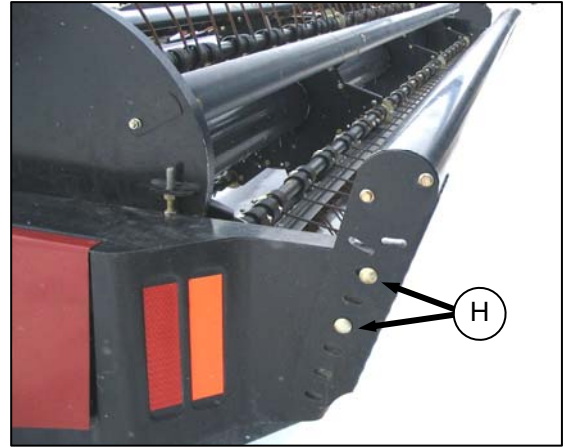
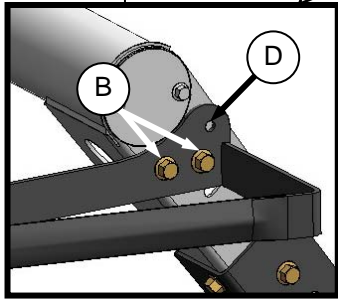
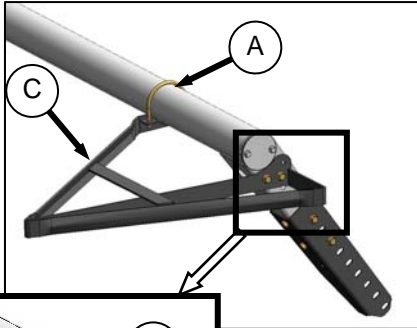

- d. Re-position lean bar on header at desired height, and install existing carriage bolts (H) - two per side. Tighten bolts.

- a. Loosen U-bolt (A).
- b. Remove bolts (B), and re-position divider (C) to align with alternate hole location (D).
- c. Re-install bolts (B), and tighten.
- d. Tighten U-bolt (A)

Proceed as follows to remove tall crop dividers:

- a. Remove U-bolt (A) and bolts (B), and remove divider. Repeat for other divider.
- b. Remove bolts attaching lean bar to header.

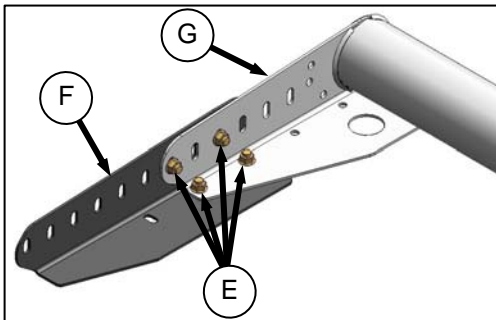

- c. Remove bolts (E) attaching extensions (F) to lean bar (G), and remove extensions.

SECTION 6 OPERATION

6.17.16 Ground Speed



CAUTION

Reduce speed when turning, crossing slopes, or when travelling over rough ground.

- Tractor/windrower ground speed should not exceed 8 mph (13 km/h). For most crop conditions a ground speed of 5 mph (8 km/h) has been found satisfactory.

- Choose a ground speed that allows the sickle to cut the crop smoothly and evenly.
- The chart below indicates the relationship between ground speed and area cut for three header sizes.

Example: At ground speed of 5 mph (8 km/h) with a 16 FT header, the area cut would be approximately 10 acres (4 hectares) per hour.

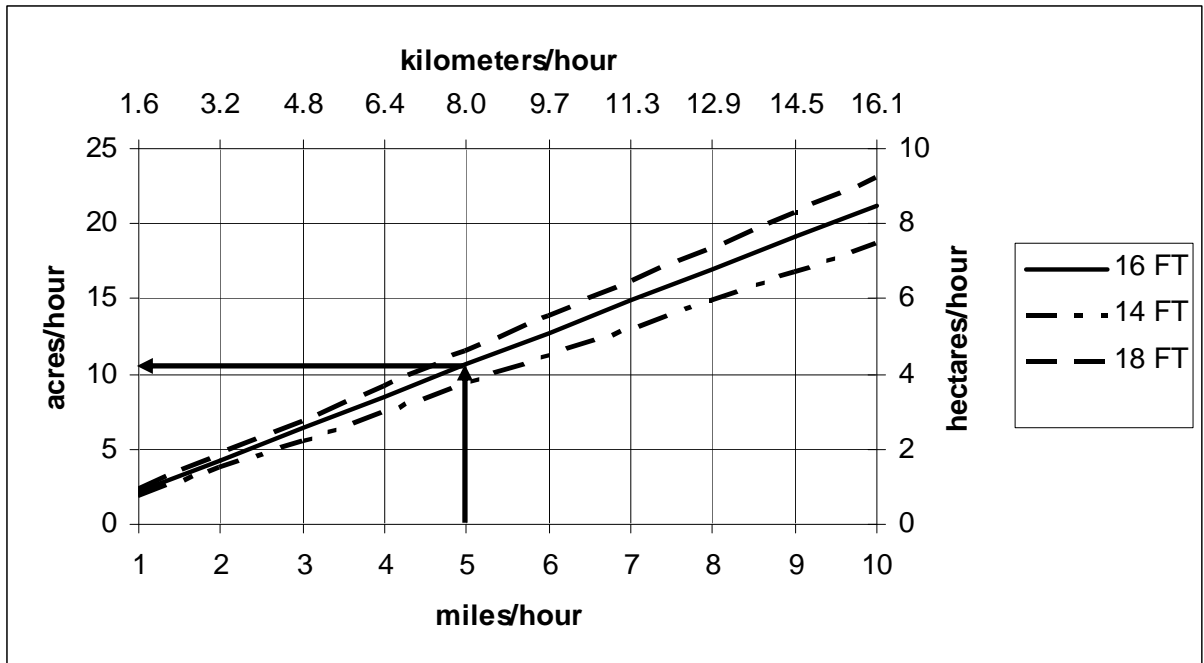

SECTION 6 OPERATION

6.17.17 Grass Seed Windrowing

The grass seed auger header has several features to adapt it to this special application. These features include:

6.17.17.1 Stub Guards and Hold-Downs

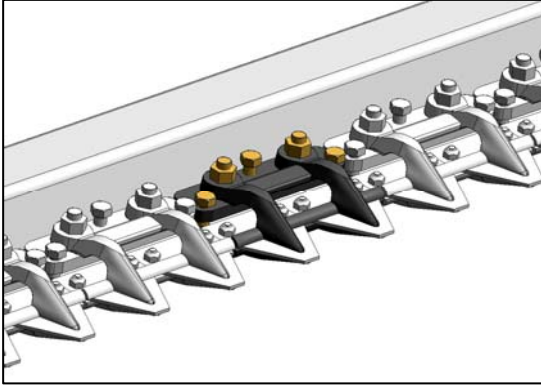

The cutterbar is equipped with stub guards for effective cutting in tough grass crops. See Section 7.8.7 *Sickle Guards* for maintenance of these components.

6.17.17.2 Special Auger Design



The center beaters and beater supports have been removed to reduce auger wrapping.

6.17.17.3 Seven Bat Reel



A seventh bat is added to the reel body, for smoother reel action and better crop feed into the header.

6.17.17.4 Auger Pan Extensions

The grass seed header is equipped with adjustable auger pan extensions that allow adjustment of delivery opening to vary the windrow characteristics. Adjust as follows:

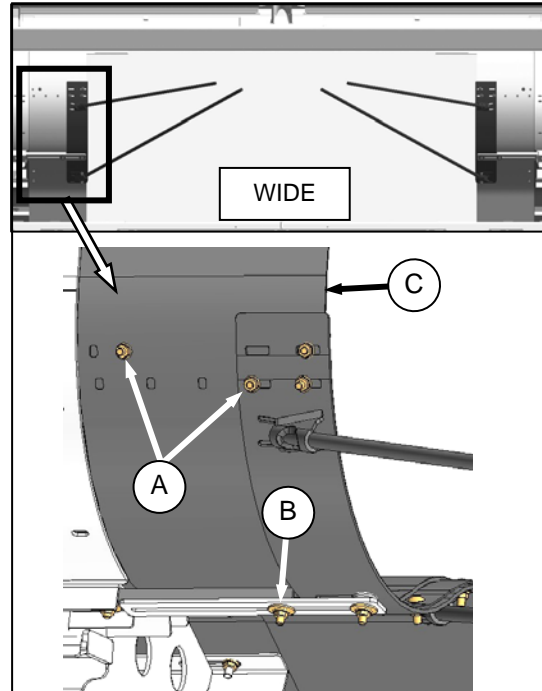

- Remove two bolts (A), and loosen bolt (B).
- Slide pan (C) and swath forming rods inboard to desired position, and align holes.

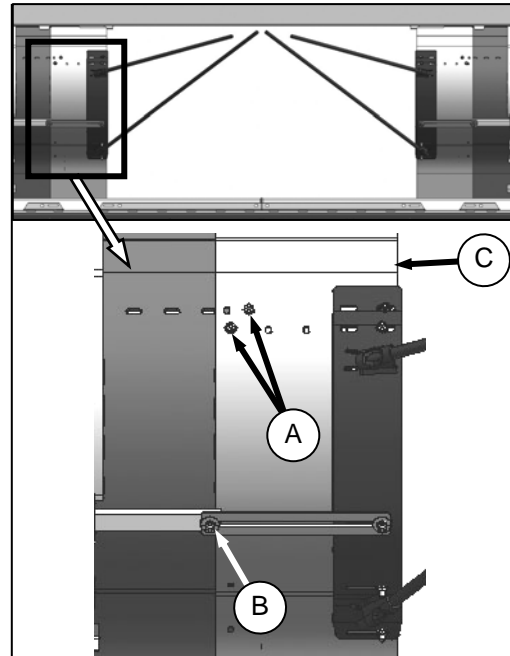

- Re-install two bolts (A), and tighten bolts (A) and (B).
- Repeat for opposite pan extension.

SECTION 6 OPERATION

6.17.17.5 Windrow Forming Rods

Forming rods are provided to assist in forming the narrow windrows preferred for this application.

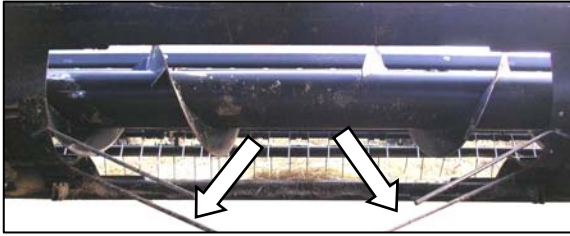

- a. Bend rods to modify the windrow shape. Use forming rods in conjunction with auger pan extensions to achieve the width and shape of windrows you desire.

SECTION 6 OPERATION

6.17.18 Recommended Settings

These settings are intended as a starting point. Operators should fine-tune to crop and field conditions. Also refer to the A Series Auger Header Quick Card that was included in your shipment.

Crop Type	Crop Condition TPA (tons per acre)	Field Condition	Header Height	Header Angle	Knife Speed	Reel RPM	Float (LBS)	Feed Pan Position	Roll Gap
Alfalfa	> 3 TPA	Smooth	0 in.	7.0–8.0	1600–1800	73–77	70–80	Lower Slot	5/8 in.
		Rocky		5.5–6.5			60–70		
	2–3 TPA	Smooth	0 in.	7.0–8.0	1600–1800	70–75	70–80	Center Slot	1/2 in.
		Rocky		5.5–6.5			60–70		
	< 2 TPA	Smooth	0 in.	8.0–8.5	1600–1800	65–70	75–85	Upper Slot	3/8 in.
		Rocky		5.5–6.5			65–70		
	Lodged	Smooth	0 in.	7.5–8.5	1600–1800	73–77	80–90	Variable	see above
		Rocky		5.5–6.5			65–75		
Timothy	> 2.5 TPA	Smooth	2.5–3 in.	7.0–8.0	1850–1950	70–75	70–80	Lower Slot	3/8 in.
		Rocky		5.5–6.0			60–70		
	< 2.5 TPA	Smooth	2.5–3 in.	7.0–8.0	1850–1950	65–70	70–80	Center Slot	1/4 in.
		Rocky		5.5–6.0			60–70		
	Lodged	Smooth	2.5–3 in.	7.0–8.5	1850–1950	70–75	80–90	Variable	see above
		Rocky		5.5–6.0			65–75		
Sudan/Tall Crop	> 3 TPA	Smooth	6 in.	7.0–8.0	1700–1850	70–75	70–80	Lower Slot	3/4 in.
		Rocky		5.5–6.0			60–70		
	< 3 TPA	Smooth	6 in.	7.0–8.0	1700–1850	65–70	70–80	Center Slot	5/8 in.
		Rocky		5.5–6.0			60–70		
	Lodged	Smooth	6 in.	7.5–8.5	1700–1850	70–75	80–90	Variable	see above
		Rocky		6.0–6.5			65–75		
Triticale (winter forage)	> 10 TPA	Smooth	0 in.	7.0–8.0	1600–1800	70–75	70–80	Lower Slot	1 inch
		Rocky		5.5–6.5			60–70		
	< 10 TPA	Smooth	0 in.	7.5–8.5	1600–1800	60–65	75–85	Center Slot	1 inch
		Rocky		6.0–6.5			65–70		
	Lodged	Smooth	0 in.	7.5–8.5	1600–1800	70–75	80–90	Variable	see above
		Rocky		6.0–6.5			65–75		
Wild/Grass Hay	> 3.5 TPA	Smooth	0 in.	7.5–8.0	1850–1950	73–77	70–80	Lower Slot	3/8 in.
		Rocky		5.5–6.5			60–70		
	2–3 TPA	Smooth	0 in.	7.5–8.0	1850–1950	70–75	70–80	Center Slot	1/4 in.
		Rocky		5.5–6.5			60–70		
	<2 TPA	Smooth	0 in.	7.5–8.5	1850–1950	65–70	75–85	Upper Slot	1/4 in.
		Rocky		6.0–6.5			65–75		
	Lodged	Smooth	0 in.	7.5–8.5	1850–1950	73–77	80–90	Variable	see above
		Rocky		6.0–6.5			65–75		

SECTION 6 OPERATION

6.18 HAYING TIPS

6.18.1 Curing

- a. A quick cure will maintain top quality because:
 - 5% of the protein is lost for each day hay lies on the ground,
 - The sooner the cut hay is off, the earlier the start for next growth.
- b. Leaving the windrow as wide and thin as possible makes for the quickest curing
- c. Cured hay should be baled as soon as possible.

6.18.2 Topsoil Moisture

LEVEL	% MOISTURE	CONDITION
Wet	Over 45%	Soil is Muddy
Damp	25–45%	Shows Footprints
Dry	Under 25%	Surface is Dusty

- a. On wet soil, the general rule of wide and thin does not apply. A narrower windrow will dry faster than hay left flat on wet ground.
- b. When the ground is wetter than the hay, moisture from the soil is absorbed by the hay above it. Determine topsoil moisture level before cutting. Use a moisture tester or estimate level:
- c. If ground is wet due to irrigation, wait until soil moisture drops below 45%.
- d. If ground is wet due to frequent rains, cut when weather allows, and let the forage lie on wet ground until it dries to the moisture level of the ground.
- e. Cut hay will dry no more until the ground under it dries, so consider moving the windrow to drier ground.

6.18.3 Weather and Topography

- a. Cut as much hay as possible by mid-day, when drying conditions are best.
- b. Fields sloping south get up to 100% more exposure to the sun's heat than do north sloping fields. If hay is baled and chopped, consider baling the south facing fields, and chopping those facing north.
- c. When relative humidity is high, the evaporation rate is low, and hay dries slower.
- d. If there is no wind, saturated air becomes trapped around the windrow. Raking or tedding will expose the hay to fresher, less saturated air.
- e. Cut hay perpendicular to the direction of the prevailing winds is also recommended.

6.18.4 Windrow Characteristics

It is recommended that a windrow with the following characteristics be produced. Refer to Section 6.17 HEADER OPERATION for instructions on adjusting the header/mower conditioner.

CHARACTERISTIC	ADVANTAGE
High And Fluffy	Movement of air through windrow is more important to the curing process than is direct sunlight.
Consistent Formation, Not Bunchy	Permits an even flow of material into the baler, chopper etc.
Even Distribution of Material Across Windrow	Results in even and consistent bales to minimize handling and stacking problems.
Properly Conditioned	Prevents excessive leaf damage.

6.18.5 Driving On Windrow

Driving on previously cut windrows can lengthen drying time by a full day in hay that will not be raked.

If practical, set forming shields for a narrower windrow that can be straddled.

NOTE

Driving on the windrow in high yielding crops may be unavoidable if a full width windrow is necessary.

6.18.6 Raking and Tedding

Raking or tedding speeds up drying, however the benefits must be weighed against the additional leaf losses which will result. There is little or no advantage to raking or tedding if the ground beneath the windrow is dry.

Large windrows on damp or wet ground should be turned over when they reach 40-50% moisture. Hay should not be raked or teded at less than 25% moisture or excessive yield losses will result.

6.18.7 Chemical Drying Agents

Hay drying agents work by removing wax from legume surfaces, enabling water to escape and evaporate faster. However, treated hay lying on wet ground will also absorb ground moisture faster.

Before deciding to use a drying agent, costs and benefits relative to your area should be carefully compared.

SECTION 6 OPERATION

6.19 STORAGE

Do the following at the end of each operating season:

- a. Clean the header/mower conditioner thoroughly.



CAUTION

Never use gasoline, naphtha or any volatile material for cleaning purposes. These materials may be toxic and/or flammable.



CAUTION

Cover cutterbar and sickle guards to prevent injury from accidental contact.

- b. Store in a dry, protected place if possible. If stored outside, always cover mower conditioner with a waterproof canvas or other protective material.
- c. Raise header, and engage lift cylinder lock-outs.
- d. If possible, block up the header to take weight off tires.
- e. Re-paint all worn or chipped painted surfaces to prevent rust.
- f. Loosen drive belts.
- g. Lubricate header/mower conditioner thoroughly, leaving excess grease on fittings to keep moisture out of bearings. Apply grease to exposed threads, cylinder rods and sliding surfaces of components. Oil sickle components to prevent rust.
- h. Check for worn components, and repair.
- i. Check for broken components and order replacement from your Dealer. Attention to these items right away will save time and effort at beginning of next season.
- j. Replace or tighten any missing or loose hardware. Refer to Section 7.3.1 *Recommended Torques*.
- k. Remove divider rods (if equipped) to reduce space required for inside storage.

SECTION 7 MAINTENANCE AND SERVICING

7 MAINTENANCE AND SERVICING

The following instructions are provided to assist the Operator in the use of the header/mower conditioner. Detailed maintenance, service, and parts information are contained in the Service Instruction Manual and Parts Catalog that are available from your Dealer.

7.1 PREPARATION FOR SERVICING



CAUTION

To avoid personal injury, before servicing header/mower conditioner or opening drive covers:

- Fully lower the header. If necessary to service in the raised position, always engage lift cylinder stops.
- Disengage PTO (pull-type).
- Stop engine, and remove key.
- Place all controls in NEUTRAL or PARK.
- Wait for all moving parts to stop.

7.2 RECOMMENDED SAFETY PROCEDURES

- Park on level surface when possible. Block wheels securely if machine is parked on an incline. Follow all recommendations in your Operator's Manuals.
- Wear close-fitting clothing, and cover long hair. Never wear dangling items such as scarves or bracelets.
- Use adequate light for the job at hand.
- Replace all shields removed or opened for service.
- Use only service and repair parts made or approved by the equipment manufacturer. Substituted parts may not meet strength, design or safety requirements.

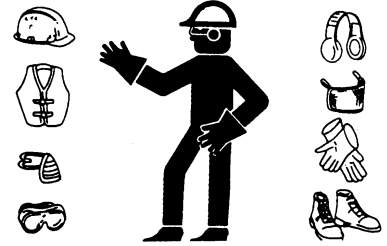

- Wear protective shoes with slip-resistant soles, a hard hat, protective glasses or goggles and heavy gloves.

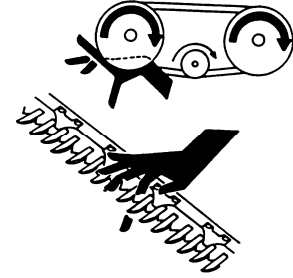

- If more than one person is servicing the machine at the same time, be aware that rotating a driveline or other mechanically driven component by hand (for example, accessing a lube fitting) will cause drive components in other areas (belts, pulleys, and sickle) to move. Stay clear of driven components at all times.



- Be prepared if an accident should occur. Know where the first aid kit and fire extinguishers are located and how to use them.
- Keep the service area clean and dry. Wet or oily floors are slippery. Wet spots can be dangerous when working with electrical equipment. Be sure all electrical outlets and tools are properly grounded.
- Keep the machine clean. Never use gasoline, naphtha or any volatile material for cleaning purposes. These materials may be toxic and/or flammable.



SECTION 7 MAINTENANCE AND SERVICING

7.3 MAINTENANCE SPECIFICATIONS

7.3.1 Recommended Torques

- Tighten all bolts to the torques specified in chart (unless otherwise noted throughout this manual).
- Check tightness of bolts periodically, using bolt torque chart as a guide.
- Replace hardware with the same strength bolt.
- Torque figures are valid for non-greased or non-oiled threads and heads unless otherwise specified. Do not grease or oil bolts or capscrews unless specified in this manual.
- When using locking elements, increase torque values by 5%.

7.3.1.1 SAE Bolts

BOLT DIA. "A" in.	NC BOLT TORQUE*			
	SAE-5		SAE-8	
	lbf-ft	N-m	lbf-ft	N-m
1/4	9	12	11	15
5/16	18	24	25	34
3/8	32	43	41	56
7/16	50	68	70	95
1/2	75	102	105	142
9/16	110	149	149	202
5/8	150	203	200	271
3/4	265	359	365	495
7/8	420	569	600	813
1	640	867	890	1205

* Torque categories for bolts and capscrews are identified by their head markings.

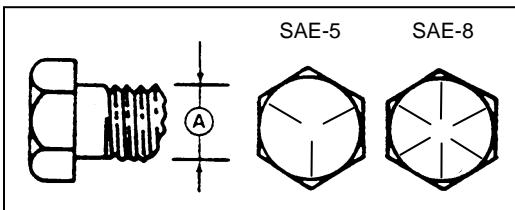

7.3.1.2 Metric Bolts

BOLT DIA. "A"	STD COARSE BOLT TORQUE*			
	8.8		10.9	
	lbf-ft	N-m	lbf-ft	N-m
M3	0.4	0.5	1.3	1.8
M4	2.2	3	3.3	4.5
M5	4	6	7	9
M6	7	10	11	15
M8	18	25	26	35
M10	37	50	52	70
M12	66	90	92	125
M14	103	140	148	200
M16	166	225	229	310
M20	321	435	450	610
M24	553	750	774	1050
M30	1103	1495	1550	2100
M36	1917	2600	2710	3675

* Torque categories for bolts and capscrews are identified by their head markings.

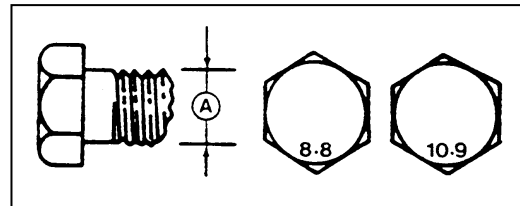

SECTION 7 MAINTENANCE AND SERVICING

7.3.1.3 Flare Type Hydraulic Fittings

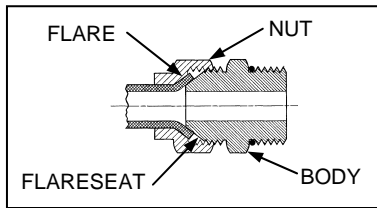

- a. Check flare and flare seat for defects that might cause leakage.
- b. Align tube with fitting before tightening.
- c. Lubricate connection, and hand-tighten swivel nut until snug.
- d. To prevent twisting the tube(s), use two wrenches. Place one wrench on the connector body, and with the second, tighten the swivel nut to the torque shown.

SAE NO.	TUBE SIZE O.D. (in.)	THD SIZE (in.)	NUT SIZE ACROSS FLATS (in.)	TORQUE VALUE*		RECOMMENDED TURNS TO TIGHTEN (AFTER FINGER TIGHTENING)	
				ft-lbf	N-m	Flats	Turns
3	3/16	3/8	7/16	6	8	1	1/6
4	1/4	7/16	9/16	9	12	1	1/6
5	5/16	1/2	5/8	12	16	1	1/6
6	3/8	9/16	11/16	18	24	1	1/6
8	1/2	3/4	7/8	34	46	1	1/6
10	5/8	7/8	1	46	62	1	1/6
12	3/4	1-1/16	1-1/4	75	102	3/4	1/8
14	7/8	1-3/16	1-3/8	90	122	3/4	1/8
16	1	1-5/16	1-1/2	105	142	3/4	1/8

* Torque values shown are based on lubricated connections as in re-assembly.

7.3.1.4 O-Ring Type Hydraulic Fittings

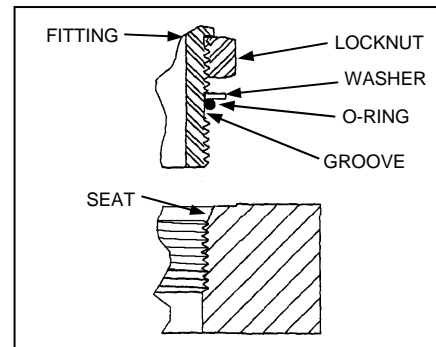

- a. Inspect O-ring and seat for dirt or obvious defects.

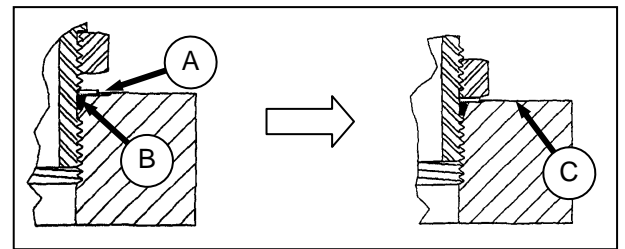

- b. On angle fittings, back off the lock nut until washer (A) bottoms out at top of groove (B) in fitting.
- c. Hand-tighten fitting until back up washer (A) or washer face (if straight fitting) bottoms on part face (C), and O-ring is seated.
- d. Position angle fittings by unscrewing **no more than one turn**.
- e. Tighten straight fittings to torque shown.
- f. Tighten angle fittings to torque shown in the following table, while holding body of fitting with a wrench.

SAE NO.	THD SIZE (in.)	NUT SIZE ACROSS FLATS (in.)	TORQUE VALUE*		RECOMMENDED TURNS TO TIGHTEN (AFTER FINGER TIGHTENING)	
			ft-lbf	N-m	Flats	Turns
3	3/8	1/2	6	8	2	1/3
4	7/16	9/16	9	12	2	1/3
5	1/2	5/8	12	16	2	1/3
6	9/16	11/16	18	24	2	1/3
8	3/4	7/8	34	46	2	1/3
10	7/8	1	46	62	1-1/2	1/4
12	1-1/16	1-1/4	75	102	1	1/6
14	1-3/16	1-3/8	90	122	1	1/6
16	1-5/16	1-1/2	105	142	3/4	1/8
20	1-5/8	1-7/8	140	190	3/4	1/8
24	1-7/8	2-1/8	160	217	1/2	1/12

* Torque values shown are based on lubricated connections as in re-assembly.

SECTION 7 MAINTENANCE AND SERVICING

7.3.1.5 O-Ring Face Seal (ORFS) Hydraulic Fittings

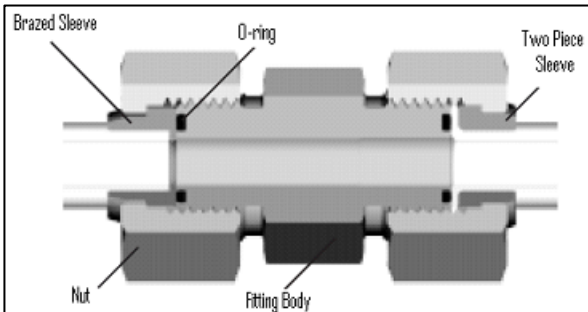
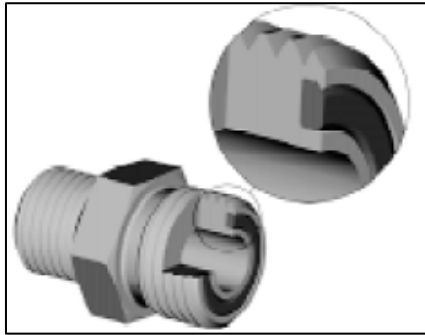

- a. Check components to ensure that the sealing surfaces and fitting threads are free of burrs, nicks, and scratches, or any foreign material.
- b. Apply lubricant (typically Petroleum Jelly) to O-ring and threads. If O-ring is not already installed, install O-ring. Align the tube or hose assembly.
- c. Ensure that flat face of the mating flange comes in full contact with O-ring.
- d. Thread tube or hose nut until hand-tight. The nut should turn freely until it is bottomed out. Torque fitting further to the specified number of F.F.F.T ("Flats From Finger Tight"), or to a given torque value in the table shown in the opposite column.

NOTE

If available, always hold the hex on the fitting body to prevent unwanted rotation of fitting body and hose when tightening the fitting nut.

- e. When assembling unions or two hoses together, three wrenches will be required.

SAE NO.	THD SIZE (in.)	TUBE O.D. (in.)	TORQUE VALUE*		RECOMMENDED TURNS TO TIGHTEN (AFTER FINGER TIGHTENING)**	
			ft-lbf	N-m	Tube Nuts	Swivel & Hose
3	***	3/16	---	---	---	---
4	9/16	1/4	11-12	14-16	1/4-1/2	1/2-3/4
5	***	5/16	---	---	---	---
6	11/16	3/8	18-20	24-27	1/4-1/2	1/2-3/4
8	13/16	1/2	32-35	43-47		
10	1	5/8	45-51	60-68		
12	1-3/16	3/4	67-71	90-95		1/3-1/2
14	1-3/16	7/8	67-71	90-95		
16	1-7/16	1	93-100	125-135		
20	1-11/16	1-1/4	126-141	170-190		
24	2	1-1/2	148-167	200-225	---	---
32	2-1/2	2	---	---	---	---

* Torque values and angles shown are based on lubricated connection, as in re-assembly.

** Always default to the torque value for evaluation of adequate torque.

*** O-ring face seal type end not defined for this tube size.

SECTION 7 MAINTENANCE AND SERVICING

7.3.2 Recommended Fluids and Lubricants

Your machine can operate at top efficiency only if clean lubricants are used.

- Use clean containers to handle all lubricants.
- Store in an area protected from dust, moisture, and other contaminants.

LUBRICANT	SPEC	DESCRIPTION	USE	CAPACITIES
Grease	SAE Multi-Purpose	High Temperature Extreme Pressure (EP2) Performance With 1% Max Molybdenum Disulphide (NLGI Grade 2). Lithium Base.	As Required Unless Otherwise Specified	---
		High Temperature Extreme Pressure (EP) Performance With 10% Max Molybdenum Disulphide (NLGI Grade 2). Lithium Base.	Driveline Slip-Joints	
Gear Lubricant	SAE 85W-140	API Service Class GL-5	Sickle Drive Box	2.3 quarts (2.2 liters)
			Conditioner Drive Gearbox	1.06 quarts (1 liters)
Hydraulic Oil	SAE 15W-40	Compliant With SAE Specs For API Class SJ And CH-4 Engine Oil.	Steering, Lift, and Header Drive Systems Reservoir	33 gal US (126 liters)

SECTION 7 MAINTENANCE AND SERVICING

7.3.3 Conversion Chart

QUANTITY	INCH-POUND UNITS		FACTOR	SI UNITS (METRIC)	
	UNIT NAME	ABBR.		UNIT NAME	ABBR.
Area	acres	acres	$\times 0.4047 =$	hectares	ha
Flow	US gallons per minute	gpm	$\times 3.7854 =$	liters per minute	L/min
Force	pounds force	lbf	$\times 4.4482 =$	Newtons	N
Length	inch	in.	$\times 25.4 =$	millimeters	mm
	foot	ft	$\times 0.305 =$	meters	m
Power	horsepower	hp	$\times 0.7457 =$	kilowatts	kW
Pressure	pounds per square inch	psi	$\times 6.8948 =$	kilopascals	kPa
			$\times .00689 =$	megapascals	MPa
Torque	pound feet or foot pounds	lbf-ft or ft-lbf	$\times 1.3558 =$	newton meters	N·m
	pound inches or inch pounds	lbf-in. or in-lbf	$\times 0.1129 =$	newton meters	N·m
Temperature	degrees Fahrenheit	°F	$(^{\circ}\text{F} - 32) \times 0.56 =$	Celsius	°C
Velocity	feet per minute	ft/min	$\times 0.3048 =$	meters per minute	m/min
	feet per second	ft/s	$\times 0.3048 =$	meters per second	m/s
	miles per hour	mph	$\times 1.6063 =$	kilometers per hour	km/h
Volume	US gallons	US gal.	$\times 3.7854 =$	liters	L
	ounces	oz.	$\times 29.5735 =$	milliliters	ml
	cubic inches	in. ³	$\times 16.3871 =$	cubic centimeters	cm ³ or cc
Weight	pounds	lb	$\times 0.4536 =$	kilograms	kg

SECTION 7 MAINTENANCE AND SERVICING

7.4 DRIVESHIELDS

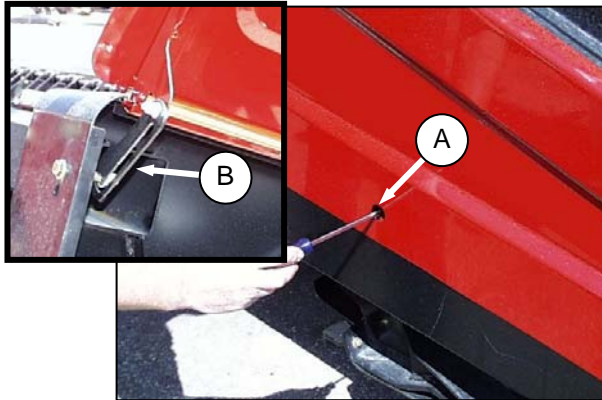

- a. To open LH and RH driveshields on header, press a screwdriver against latch in opening at (A).



CAUTION

Ensure shield lock engages in the open position as shown at (B) before letting go of shield.

- b. To close, push shield slightly farther open, and move lock (B) out of the engagement slot. Lower shield by hand, and release about 12 in. (300 mm) from fully closed position. Shield will self-latch.

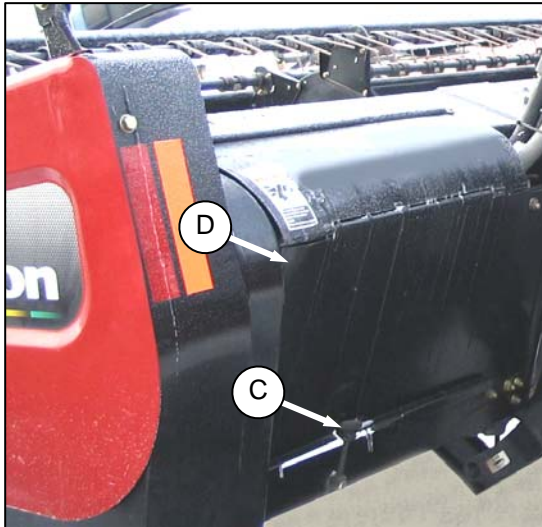

- c. To open driveline shield, disengage rubber latch (C), and open shield (D).
- d. To close, lower shield (D), and engage rubber latch (C).

7.5 LIFT CYLINDER LOCK-OUTS

7.5.1 Self-Propelled

Refer to your Windrower Operator's Manual.

7.5.2 Pull-Type



DANGER

To avoid bodily injury or death from unexpected start-up or fall of raised machine; stop engine, remove key and engage lift cylinder lock-out valves before going under machine for any reason.

- a. Raise header fully, shut off engine, and remove key.



- b. Move handle to horizontal position on both header lift cylinder lock-out valves.

SECTION 7 MAINTENANCE AND SERVICING

7.6 LUBRICATION



CAUTION

To avoid personal injury, before servicing header/mower conditioner or opening drive covers, follow procedures in Section 7.1 PREPARATION FOR SERVICING.

Refer to Section 7.3.2 *Recommended Fluids and Lubricants* for recommended greases.

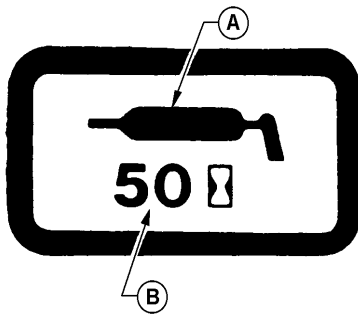

SAMPLE GREASE DECAL

The greasing points are marked on the machine by decals showing a grease gun (A), and grease interval (B) in hours of operation.

Log hours of operation and use the "Maintenance Checklist" provided to keep a record of scheduled maintenance. Refer to Section 7.18 MAINTENANCE SCHEDULE.

7.6.1 Greasing Procedure

- Wipe grease fitting with a clean cloth before greasing, to avoid injecting dirt and grit.
- Inject grease through fitting with grease gun until grease overflows fitting, except where noted.
- Leave excess grease on fitting to keep out dirt.
- Replace any loose or broken fittings immediately.
- If fitting will not take grease, remove and clean thoroughly. Also clean lubricant passageway. Replace fitting if necessary.

7.6.2 Lubrication Points

Lubrication requirements depend on the model of header/mower conditioner that is being serviced.

Refer to the specified pages to identify lubrication points for your specific model:

A30-S HEADER	Pages 105–106
A30-D HEADER	Pages 107–108
A40-D HEADER	Pages 109–110
HAY CONDITIONER	Page 111
DRIVELINES	Page 112
PULL-TYPE CARRIER	Page 113

SECTION 7 MAINTENANCE AND SERVICING

I. A30-S Headers

A30-S HEADER LH SIDE

High Temperature Extreme Pressure (EP2) Performance With 1% Max Molybdenum Disulphide (NLGI Grade 2) Lithium Base.

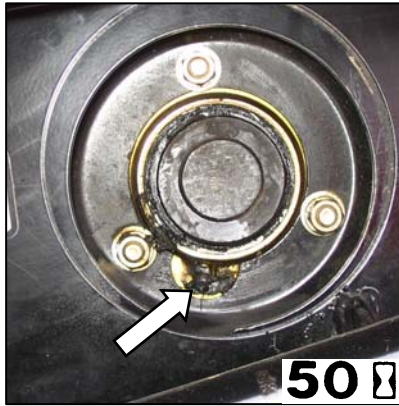

REEL SHAFT BEARING (1 PLC)

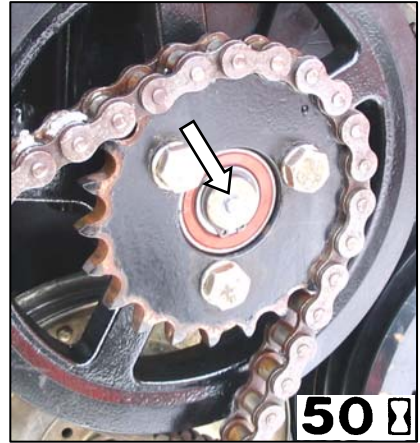

AUGER DRIVE BEARING (1 PLC)

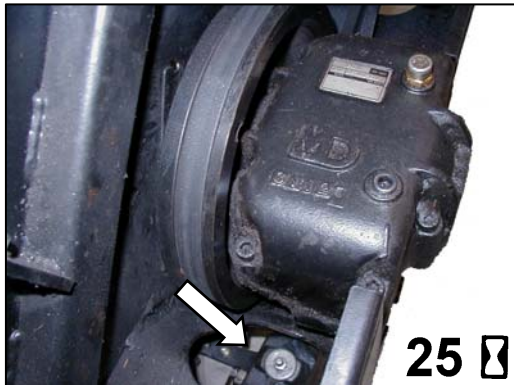
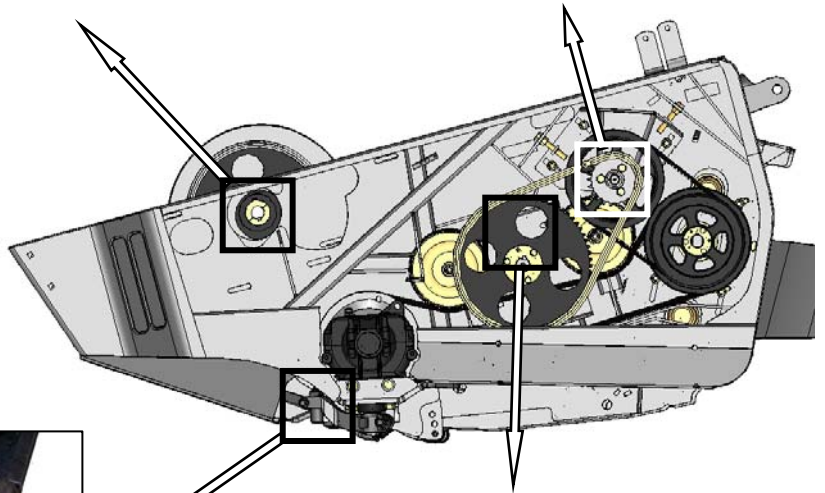

SICKLE HEAD BEARING (1 PLC)

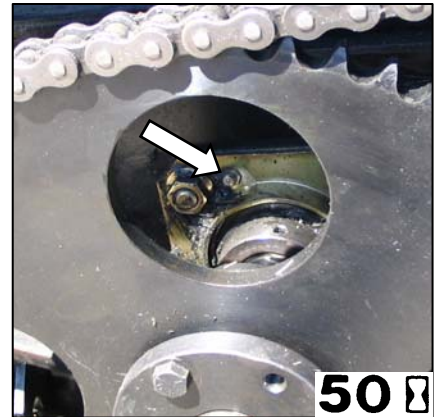

AUGER SHAFT BEARING (1 PLC)

NOTE

To prevent binding and/or excessive wear caused by sickle pressing on guards, do not over grease. If more than 6 to 8 pumps of the grease gun are required to fill the cavity, replace the seal in the sickle head.

SECTION 7 MAINTENANCE AND SERVICING

A30-S Headers (Cont'd)

A30-S HEADER RH SIDE

High Temperature Extreme Pressure
(EP2) Performance With 1% Max
Molybdenum Disulphide (NLGI
Grade 2) Lithium Base.

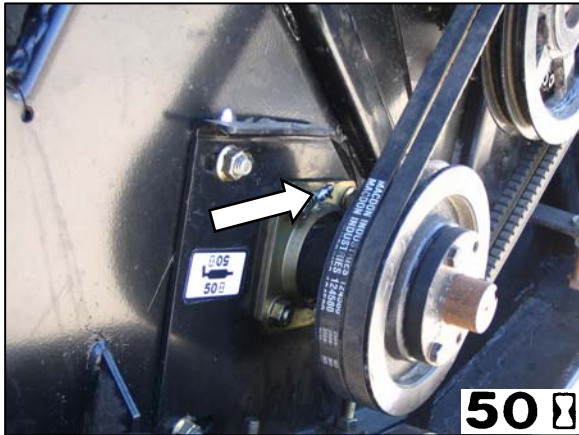
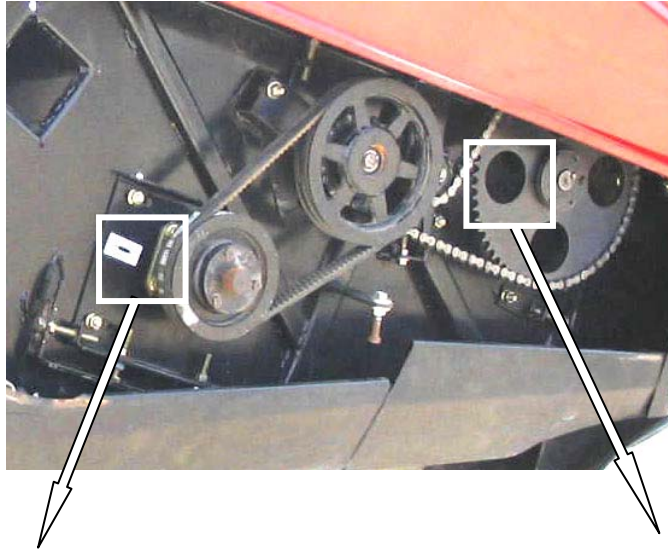

AUGER SHAFT BEARING (1 PLC)

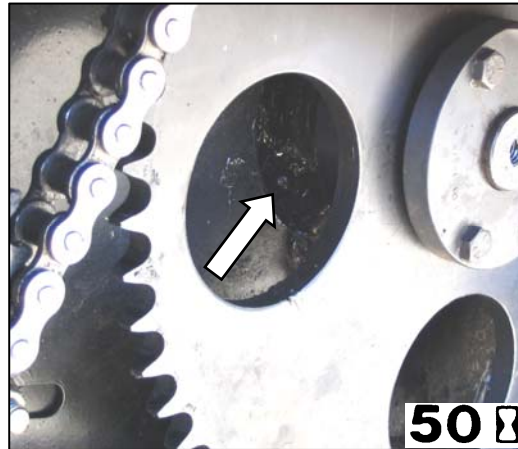

REEL SHAFT BEARING (1 PLC)

SECTION 7 MAINTENANCE AND SERVICING

II. A30-D Headers

A30-D HEADER RH SIDE

High Temperature Extreme Pressure
(EP2) Performance With 1% Max
Molybdenum Disulphide
(NLGI Grade 2) Lithium Base.

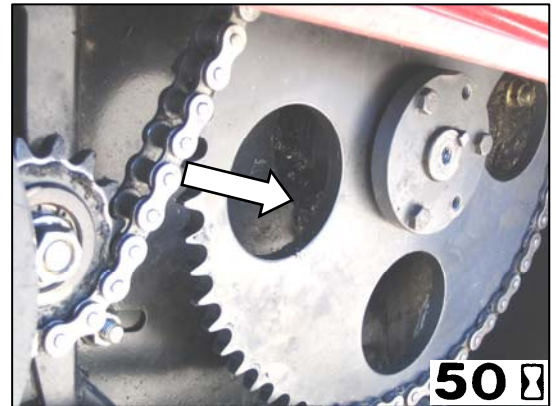

REEL SHAFT BEARING (1 PLC)

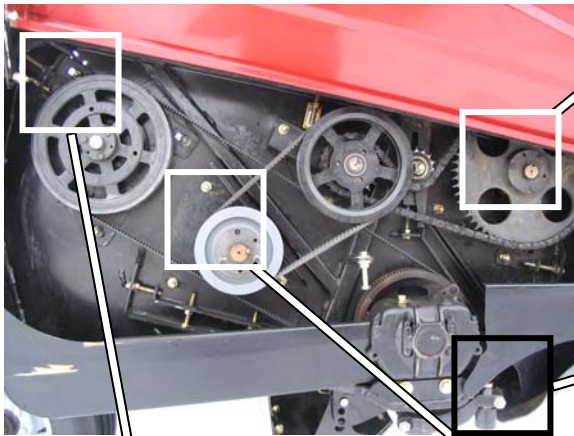

SICKLE HEAD BEARING (1 PLC)

NOTE

To prevent binding and/or excessive wear caused by sickle pressing on guards, do *not* over-grease. If more than 6 to 8 pumps of grease gun are required to fill the cavity, replace the seal in the sickle head.

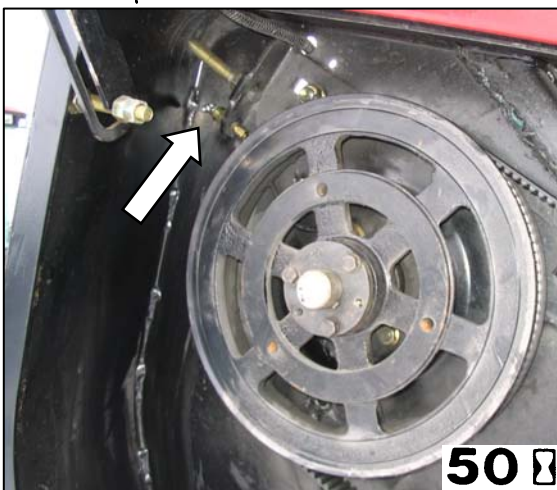

SICKLE DRIVE BEARING (1 PLC)

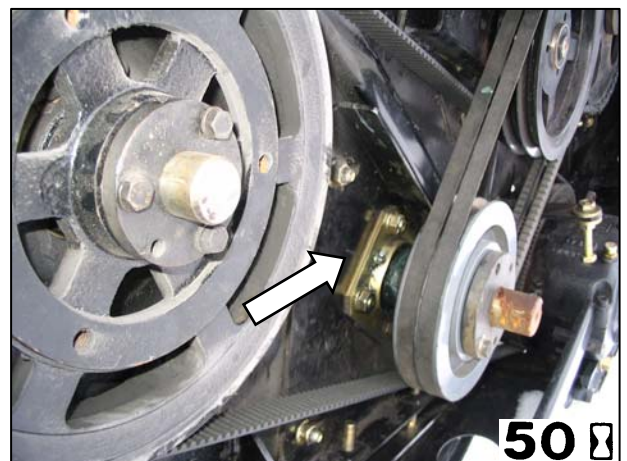

AUGER SHAFT BEARING (1 PLC)

SECTION 7 MAINTENANCE AND SERVICING

A30-D Headers (Cont'd)

A30-D HEADER LH SIDE

High Temperature Extreme Pressure (EP2) Performance With 1% Max Molybdenum Disulphide (NLGI Grade 2) Lithium Base.

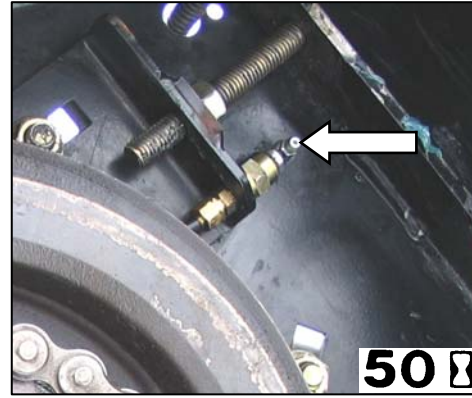

CROSS SHAFT BEARING (1 PLC)



REEL SHAFT BEARING (1 PLC)

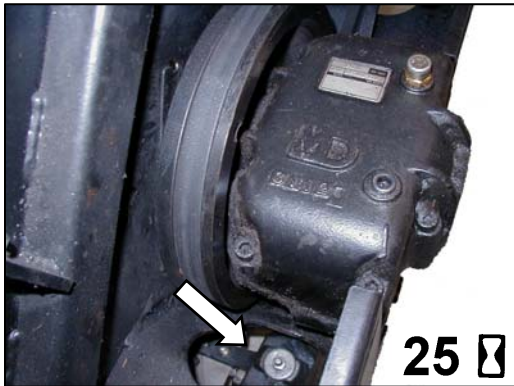
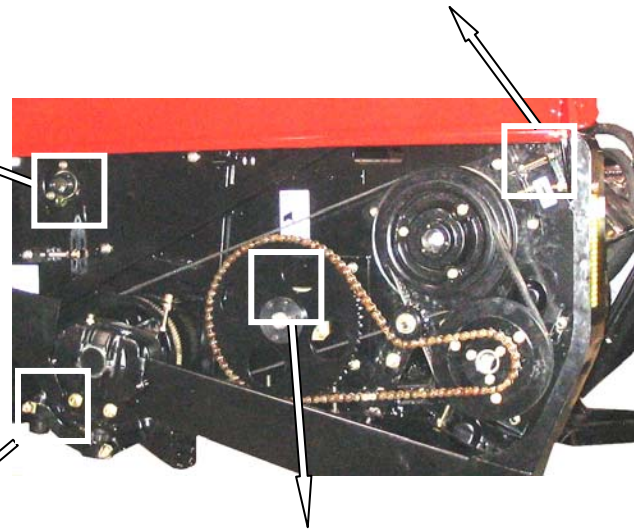

SICKLE HEAD BEARING (1 PLC)

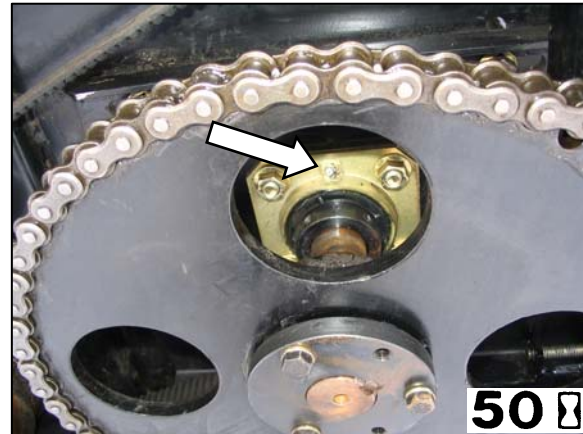

AUGER SHAFT BEARING (1 PLC)

NOTE

To prevent binding and/or excessive wear caused by sickle pressing on guards, do not over-grease. If more than 6 to 8 pumps of grease gun are required to fill the cavity, replace the seal in the sickle head.

SECTION 7 MAINTENANCE AND SERVICING

III. A40-D HEADERS

A40-D HEADER RH SIDE

High Temperature Extreme Pressure (EP2) Performance With 1% Max Molybdenum Disulphide (NLGI Grade 2) Lithium Base.

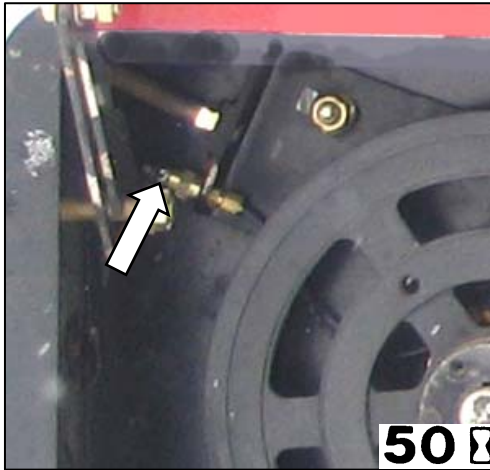

SICKLE DRIVE BEARING (1 PLC)

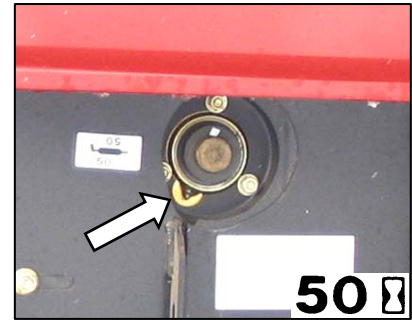

REEL SHAFT BEARING (1 PLC)

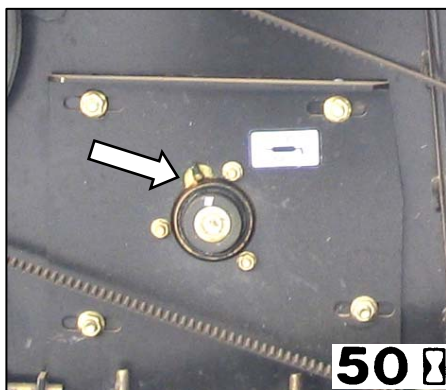
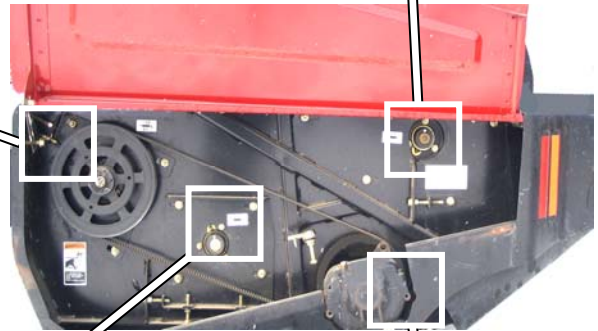

AUGER SHAFT BEARING (1 PLC)

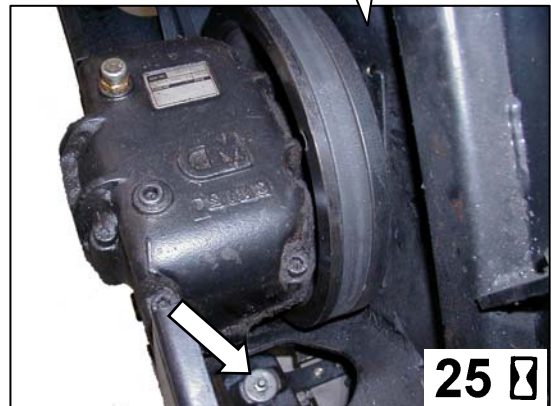

SICKLE HEAD BEARING (1 PLC)

NOTE

To prevent binding and/or excessive wear caused by sickle pressing on guards, do not over-grease. If more than 6 to 8 pumps of grease gun are required to fill the cavity, replace the seal in the sickle head.

SECTION 7 MAINTENANCE AND SERVICING

A40-D Headers (Cont'd)

A40-D HEADER LH SIDE

High Temperature Extreme Pressure (EP2) Performance With 1% Max Molybdenum Disulphide (NLGI Grade 2) Lithium Base.

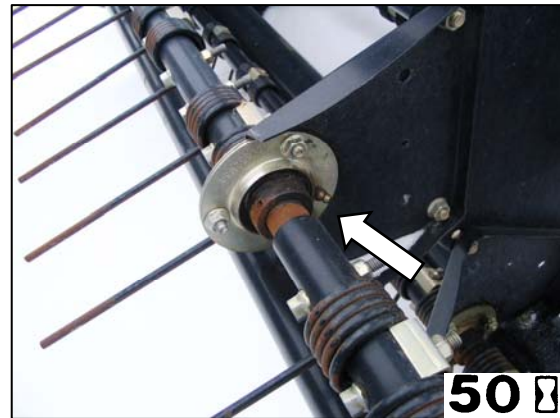

TINE BAR BEARING
(4 PLCS EACH TINE BAR)

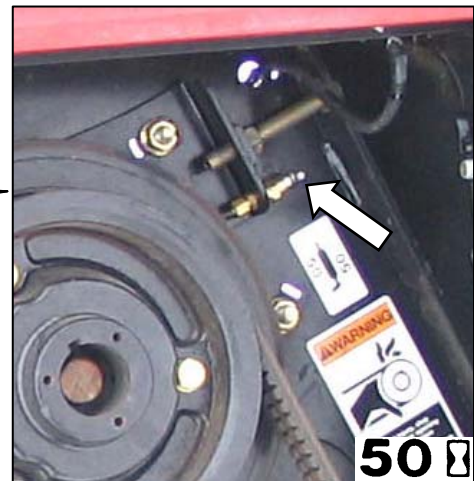
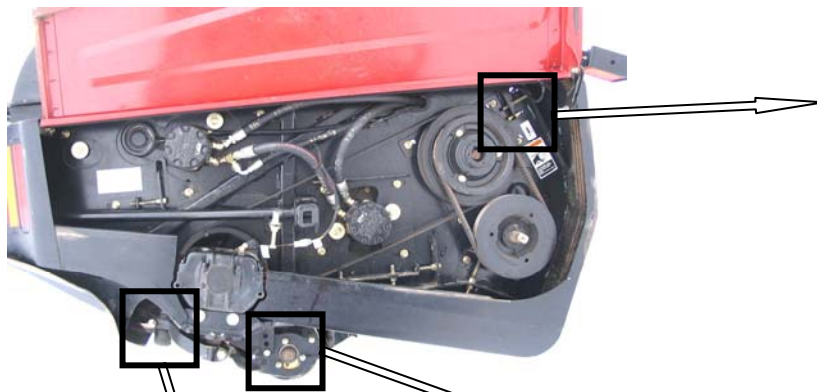

SICKLE DRIVE BEARING (1 PLC)



SICKLE HEAD BEARING (1 PLC)

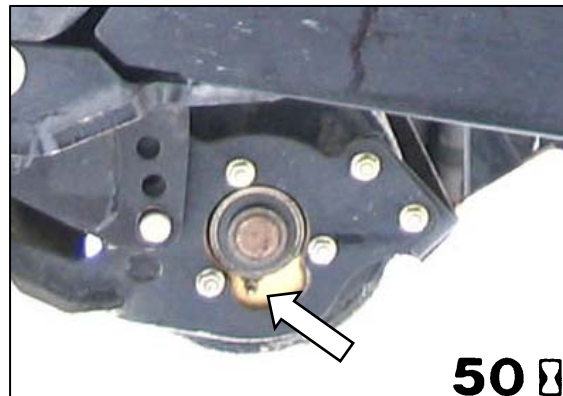

GAUGE ROLLER BEARINGS (2 PLCS)
BOTH SIDES - IF INSTALLED

NOTE

To prevent binding and/or excessive wear caused by sickle pressing on guards, do not over-grease. If more than 6 to 8 pumps of grease gun are required to fill the cavity, replace the seal in the sickle head.

SECTION 7 MAINTENANCE AND SERVICING

IV. HAY CONDITIONER

High Temperature Extreme Pressure (EP2) Performance With **1% Max Molybdenum Disulphide** (NLGI Grade 2) Lithium Base.

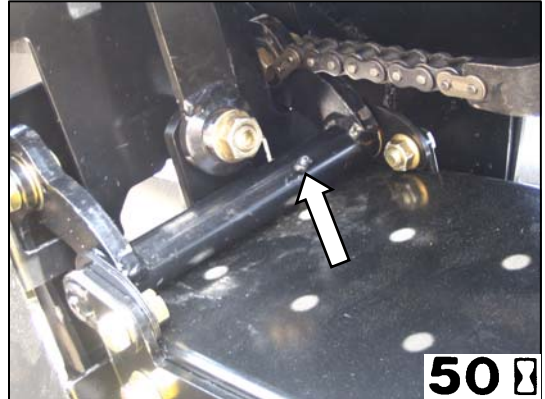

ROLL PIVOT (1 PLC - BOTH SIDES)



ROLL SHAFT BEARINGS (2 PLCS)

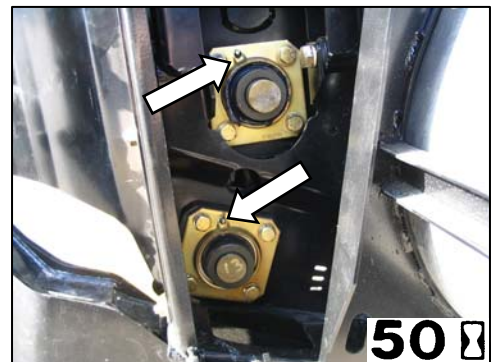

ROLL SHAFT BEARINGS (2 PLCS)

SECTION 7 MAINTENANCE AND SERVICING

V. DRIVELINES

High Temperature Extreme Pressure (EP2) Performance With 1% Max Molybdenum Disulphide (NLGI Grade 2) Lithium Base.

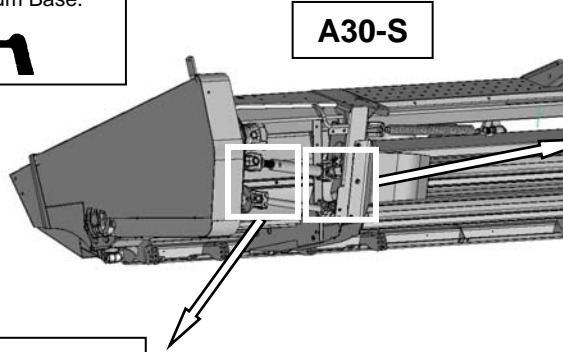

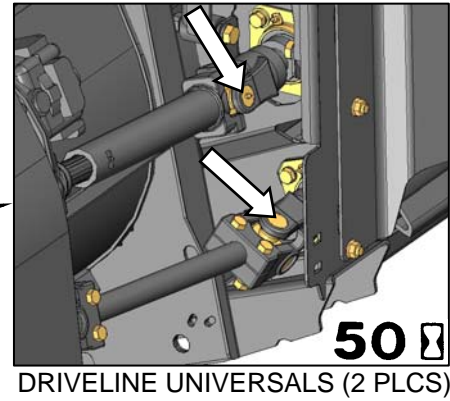

A30-S



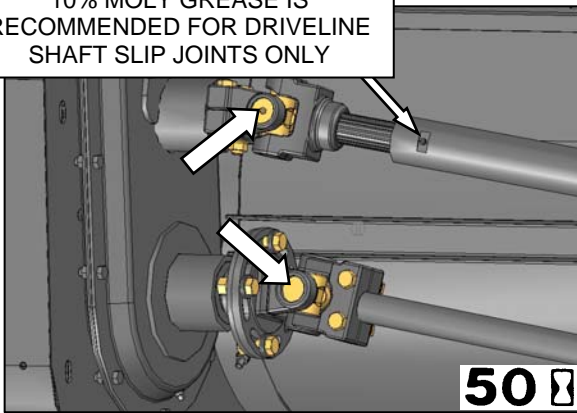

50 
DRIVELINE UNIVERSALS (2 PLCS)

10% MOLY GREASE IS RECOMMENDED FOR DRIVELINE SHAFT SLIP JOINTS ONLY

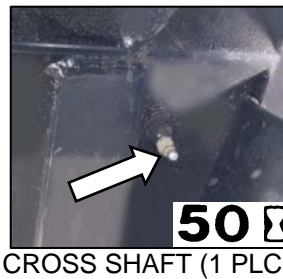

50 
DRIVELINE UNIVERSALS (2 PLCS)
DRIVELINE SHAFTS (1 PLC)



50 
CROSS SHAFT (1 PLC)



50 
CROSS SHAFT (1 PLC)

10% MOLY GREASE IS RECOMMENDED FOR DRIVELINE SHAFT SLIP JOINTS ONLY



50 
DRIVELINE UNIVERSALS (2 PLCS)
DRIVELINE SHAFTS (2 PLCS)

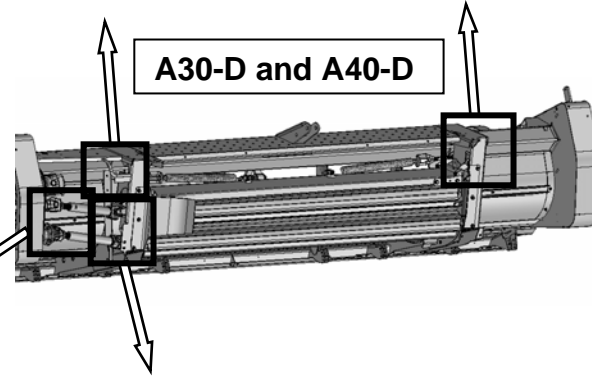

A30-D and A40-D



50 
DRIVELINE UNIVERSALS (2 PLCS)

SECTION 7 MAINTENANCE AND SERVICING

VI. PULL-TYPE CARRIER FRAME

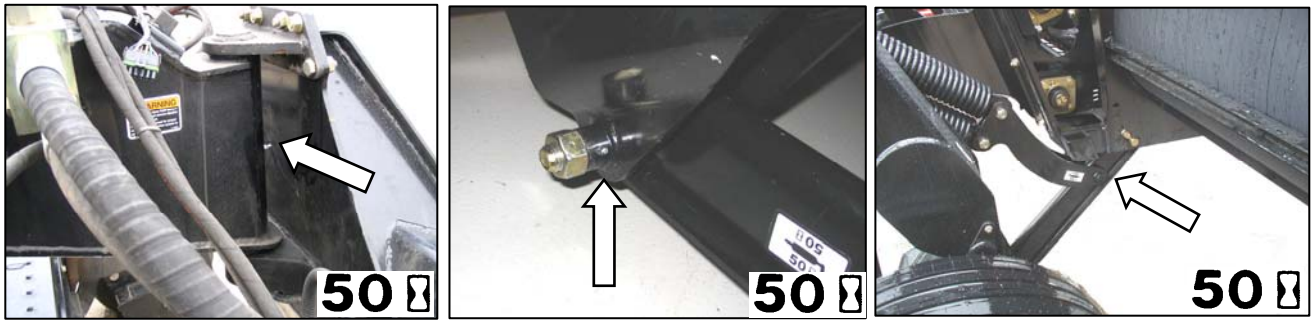

TONGUE PIVOT (1 PLC)

LIFT LINKAGE (2 PLCS) - BOTH SIDES

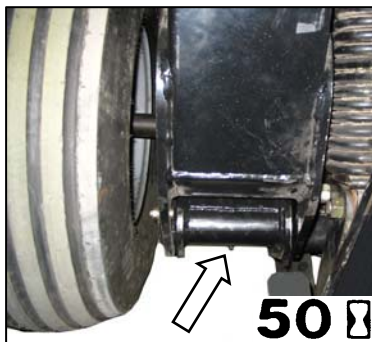
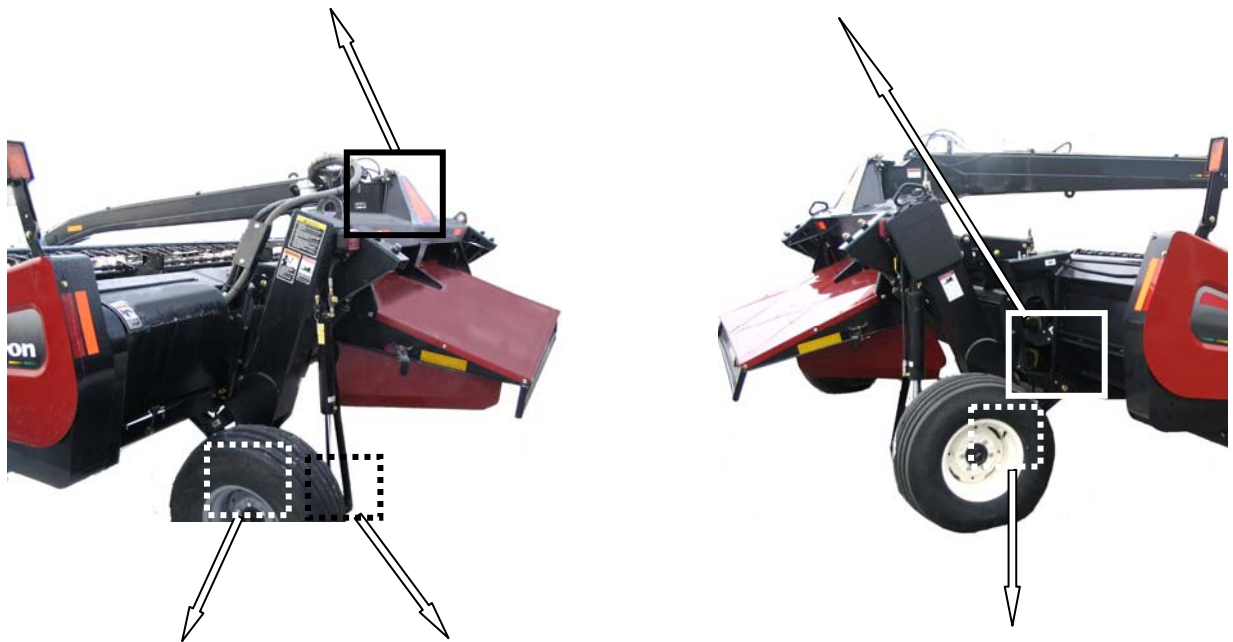

FRAME/HEADER PIVOT
(1 PLC) - BOTH SIDES

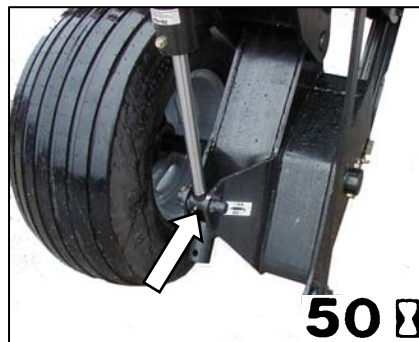

LIFT CYLINDER (1 PLC)



WHEEL BEARINGS
(1 PLC) - BOTH SIDES

SECTION 7 MAINTENANCE AND SERVICING

7.6.3 Oiling

Refer to the following illustration to identify the various locations that require lubrication. See *Section 7.3.2 Recommended Fluids and Lubricants* for proper oil.

Apply oil to upper edge of lower spans when oiling chains.

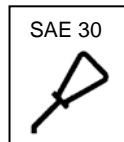

A30-S HEADER

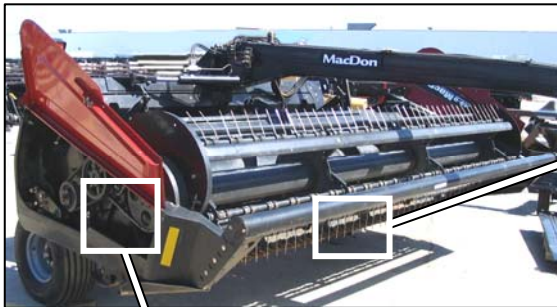

OIL KNIFE DAILY EXCEPT IN SANDY SOIL

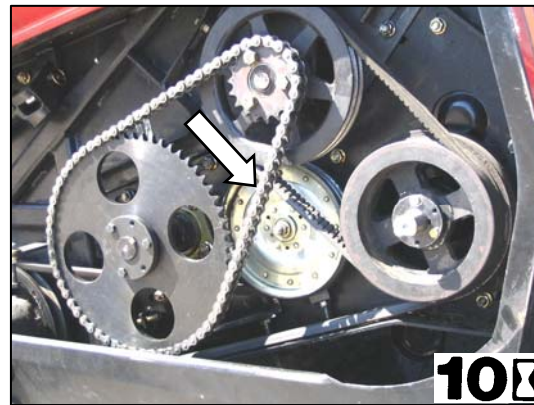

AUGER DRIVE CHAIN (1 PLC)

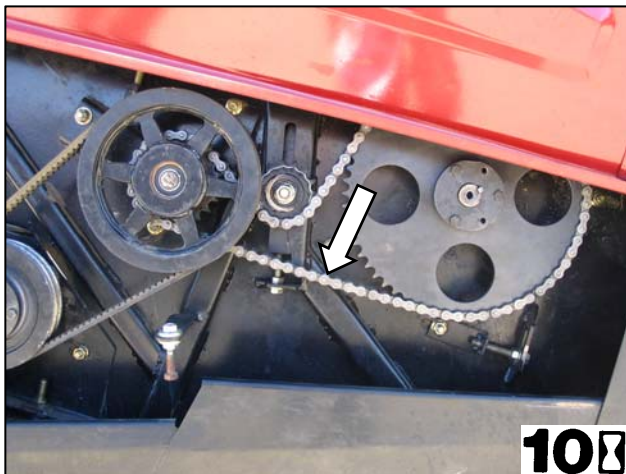

REEL DRIVE CHAIN (1 PLC)

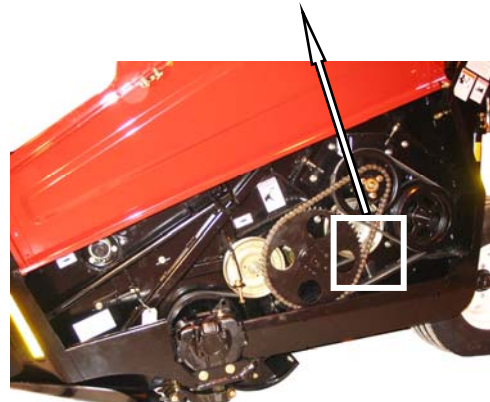

A30-S HEADER LH SIDE

SECTION 7 MAINTENANCE AND SERVICING

Oiling (Cont'd)

A30-D HEADER LH SIDE

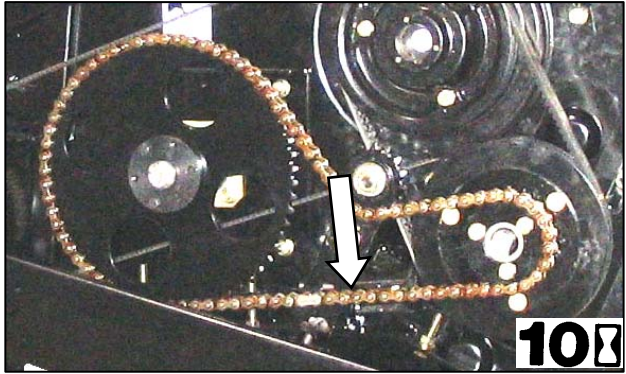

AUGER DRIVE CHAIN (1 PLC)

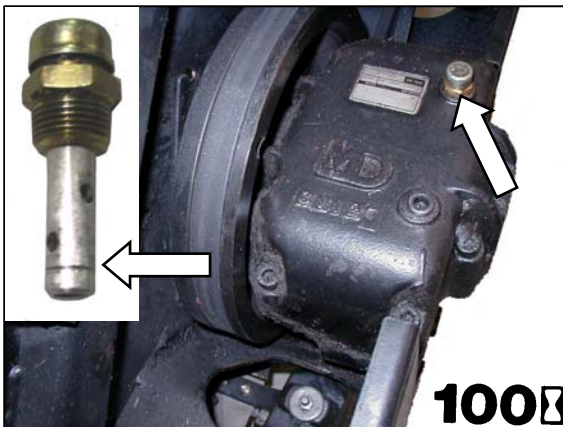
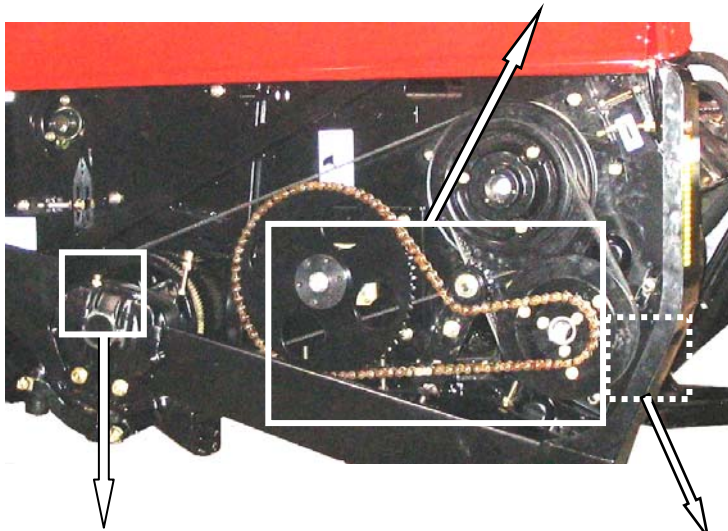

SICKLE DRIVE BOX
(A30-S 1 PLC) (A30-D / A40-D 2 PLCS)
(CHECK OIL LEVEL WITH TOP OF
SICKLE DRIVE BOX HORIZONTAL)

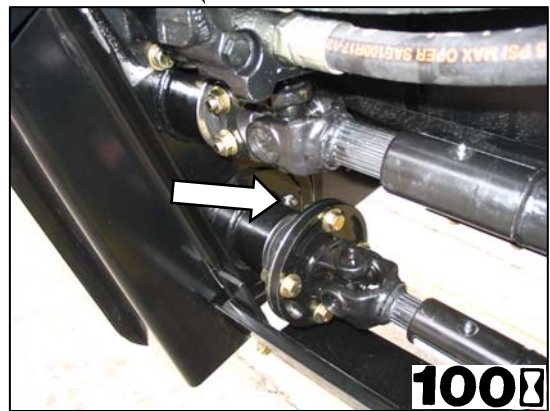

CHECK ROLL GEARBOX (1 PLC)

SECTION 7 MAINTENANCE AND SERVICING

7.6.4 Sealed Bearing Installation

- a. Clean shaft, and coat with rust preventative.

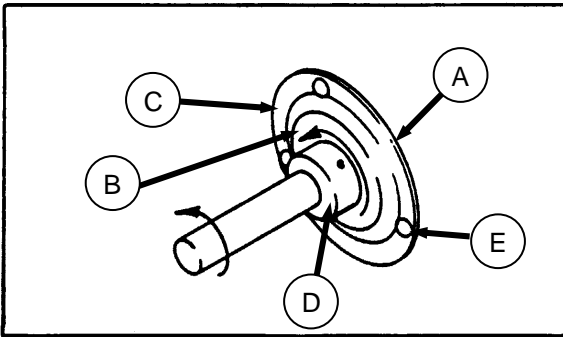

- b. Install flangette (A), bearing (B), second flangette (C), and lock collar (D).

NOTE

The locking cam is only on one side of the bearing.

- c. Install (but do not tighten) flangette bolts (E).
- d. When shaft is correctly located, lock the lock collar with a punch.

NOTE

The collar should be locked in the same direction the shaft rotates. Tighten the set screw in the collar.

- e. Tighten flangette bolts (E).
- f. Loosen flangette bolts on mating bearing one turn, and re-tighten. This will allow the bearing to line up.

SECTION 7 MAINTENANCE AND SERVICING

7.7 HYDRAULICS

7.7.1 Hydraulics: Self-Propelled

Refer to your Self-Propelled Windrower Operator's Manual for hydraulic system maintenance procedures for self-propelled windrowers.

7.7.2 Hydraulics: Pull-Type

The pull-type mower conditioner is hydraulically powered using the following systems:

- A self-contained hydraulic system to operate the header functions.
- The tractor remote system to operate the header lift cylinders and steering.



WARNING

Do **not** use remote hydraulic system pressures over 3000 psi (20684 kPa). Check your tractor's Operator's Manual for remote system pressure.

7.7.2.1 Reservoir

The mower conditioner's self-contained hydraulic system uses the APT of the machine for the hydraulic oil reservoir.

7.7.2.2 Oil Level

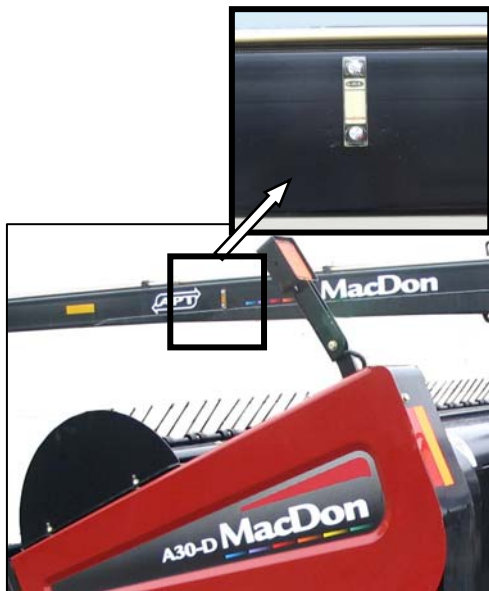

Check oil level daily (before start-up) at the sight gauge on the left side of the APT. Oil level should be at or near FULL mark on the gauge when top surface of APT is level, and oil is cold.

7.7.2.3 Adding Hydraulic Oil

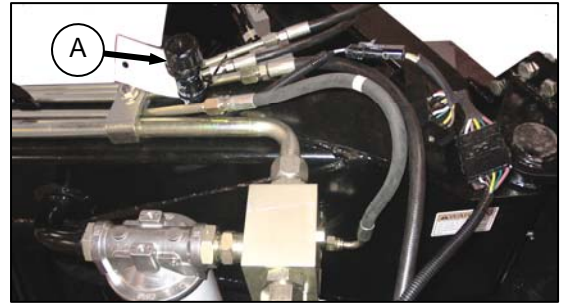

- Slowly unscrew filler cap (A) from filler tube.
- Add SAE 15W40 oil until level is between ADD and FULL marks on sight gauge.
- Replace filler cap.

7.7.2.4 Changing Hydraulic Oil

NOTE

Change hydraulic oil every 500 hours, or 3 years.

NOTE

A drain pan with a capacity of 35 US gallons (130 liters) will be required.

NOTE

Mower conditioner must be disconnected from tractor. Refer to Section 6.5 MOWER CONDITIONER/TRACTOR UNHOOK: PULL-TYPE.

- Remove filler cap (A) at aft end of APT.

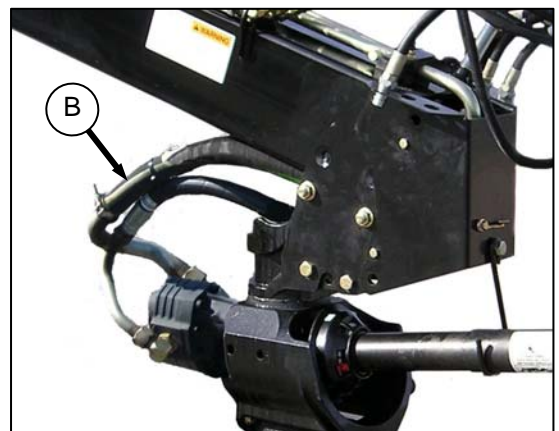

- Disconnect pump suction hose (B) from pump, and drain into container.
- Re-connect pump suction hose to pump.
- Fill reservoir to recommended level with SAE 15W30 oil. Capacity is 33 US gallons (126 liters).

SECTION 7 MAINTENANCE AND SERVICING

7.7.2.5 Changing Hydraulic Oil Filter

NOTE

Change hydraulic oil filter after the first 100 hours operation, and every 250 hours thereafter.

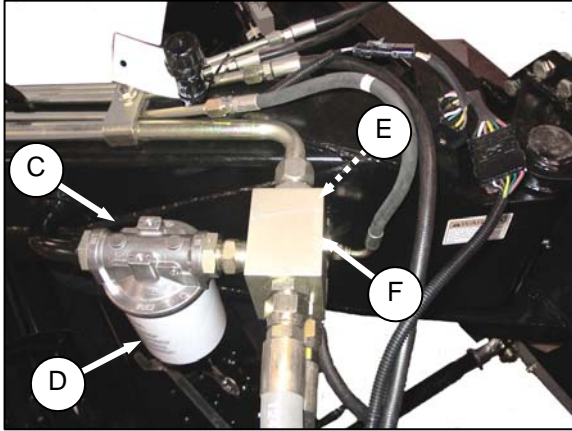

- Clean around filter head (C).
- Remove filter (D), and clean gasket surface of the filter head.
- Apply a thin film of clean oil to the gasket on the new filter.
- Install new filter. Turn filter onto the mount until the gasket contacts the filter head. Tighten the filter an additional 1/2 to 3/4 turn by hand.

IMPORTANT

Do not use a filter wrench to install the filter. Over-tightening can damage gasket and filter.

7.7.2.6 Pressure Relief Valve

A possible cause of poor cutting performance and/or excessive heating of hydraulic oil is low relief pressure.

The relief valve (E) is factory-set at 4000 psi (27.6 MPa). See your Dealer for adjustment or service. A pressure gauge can be installed at the gauge port (F) as shown above.

7.7.3 Hoses and Lines

Check hydraulic hoses and lines daily for signs of leaks.



WARNING

Avoid high-pressure fluids. Escaping fluid can penetrate the skin causing serious injury. Relieve pressure before disconnecting hydraulic lines.



Tighten all connections before applying pressure. Keep hands and body away from pin-holes and nozzles which eject fluids under high pressure.

If ANY fluid is injected into the skin, it must be surgically removed within a few hours by a doctor familiar with this type of injury or gangrene may result.

Use a piece of cardboard or paper to search for leaks.

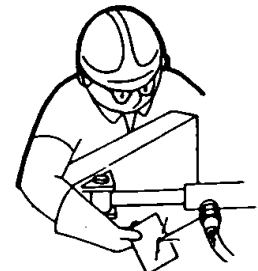

IMPORTANT

Keep hydraulic coupler tips and connectors clean. Dust, dirt, water and foreign material are the major causes of hydraulic system damage.

DO NOT attempt to service hydraulic system in the field. Precision fits require WHITE ROOM CARE during overhaul.

SECTION 7 MAINTENANCE AND SERVICING

7.8 SICKLE AND SICKLE DRIVE



CAUTION

To avoid personal injury, before servicing header/mower conditioner or opening drive covers, follow procedures in Section 7.1 PREPARATION FOR SERVICING.



CAUTION

Wear heavy gloves when working around or handling sickles.

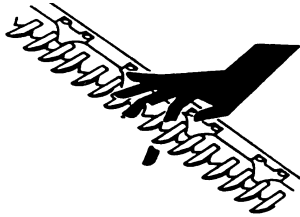

WARNING

Keep hands clear of the area between guards and sickle at all times.

7.8.1 Sickle Section Replacement

Check daily that sections are firmly bolted to the sickle back, and are not worn or broken. Replace as required. A worn or broken sickle section can be replaced without removing sickle from cutterbar.

- Stroke sickle as required to expose sickle sections.

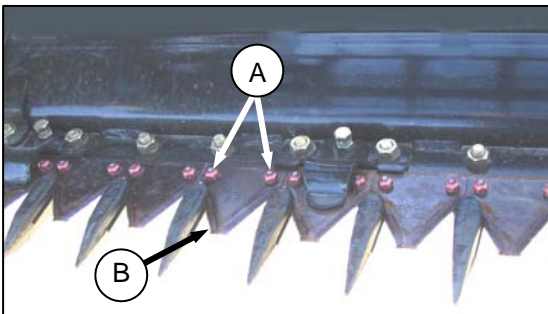

- Remove lock nuts (A), and lift section (B) off of bolts.

IMPORTANT

Do not mix heavy and light sickle sections on same sickle.

- Clean any dirt off of sickle back, and position new sickle section on bolts.
- Secure with lock-nuts, and tighten to required torque.

7.8.2 Sickle Removal



WARNING

Stand to rear of sickle during removal to reduce risk of injury from cutting edges. Wear heavy gloves when handling sickle.

- Stroke sickle to its outer limit.

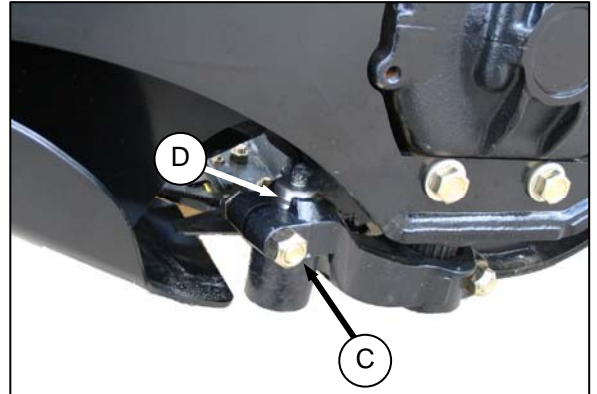

- Clean area around sickle head, and remove nut and bolt (C).
- Remove grease zerk from pin (D).
- Insert screwdriver in groove of pin (D), and pry up on sickle head pin to free sickle. Pin does not have to be removed from arm.
- Pull sickle out.
- Cover sickle head to shield bearing from dirt.

SECTION 7 MAINTENANCE AND SERVICING

7.8.3 Sickle Installation



WARNING

Stand to rear of sickle during installation to reduce risk of injury from cutting edges. Wear heavy gloves when handling sickle.

IMPORTANT

Align guards, and re-set sickle hold-downs while replacing sickle.

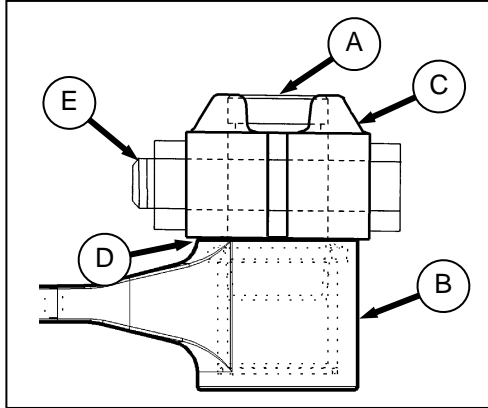

- If sickle head pin (A) is installed in the sickle head (B), remove the pin.
- Slide sickle into place, and align sickle head (B) with pitman arm.
- Install sickle head pin (A) in pitman arm (C), and tap it down into the sickle head, ensuring pin is bottomed out in the sickle head.
- Tap underside of the sickle head until pin is flush with the upper face of the pitman arm (C).
- Carefully adjust to achieve a 0.010 in. (.25 mm) gap at (D) with the knife laying flat on the first few guards.
- Replace bolt (E) and nut.
- Tighten nut to 160 ft·lbf (220 N·m).

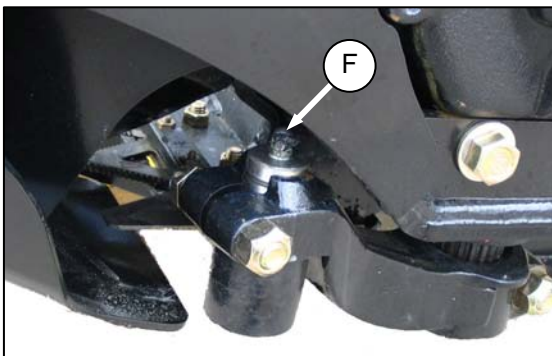

- Replace grease zerk (F) in pin.
- Grease bearing (if it has been replaced).

7.8.4 Sickle Head Bearing Removal

- Remove the sickle. See Section 7.8.2 *Sickle Removal*.

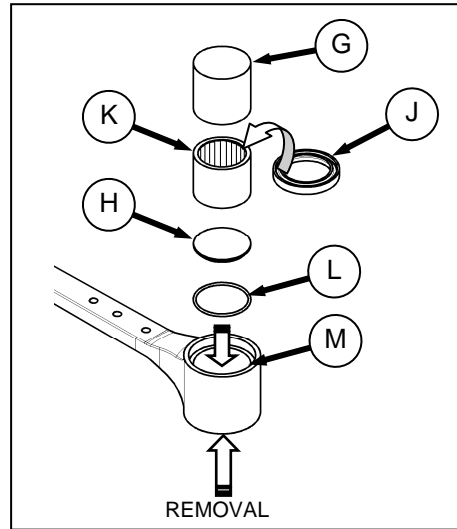

- Using a flat-ended tool (G) with approximately the same diameter as the plug (H), tap out the seal (J), bearing (K), and plug (H) from the underside of the head.

NOTE

The seal can be replaced without removing the bearing. When changing seal, check pin and needle bearing for wear. Replace if necessary.

7.8.5 Sickle Head Bearing Installation

- Place O-ring (L) and plug (H) in sickle head.

IMPORTANT

Assemble bearing with the stamped end (the end with identification markings) against the tool.

- Using a flat-ended tool (G) with approximately the same diameter as bearing (K), push bearing into the sickle head until the top of the bearing is flush with the step (M) in sickle head.
- Install seal (J) in top of sickle head with lip facing outwards.

IMPORTANT

To avoid premature sickle head or sickle drive box failure, be sure there is no looseness in the following:

- Fit of sickle head pin and needle bearing.
 - Fit of sickle head pin and pitman arm.
- Install sickle.

SECTION 7 MAINTENANCE AND SERVICING

7.8.6 Spare Sickle

- a. A spare sickle complete with knife head on single knife headers may be stored in the header frame tube at RH end as shown. Ensure sickle is secured in place.

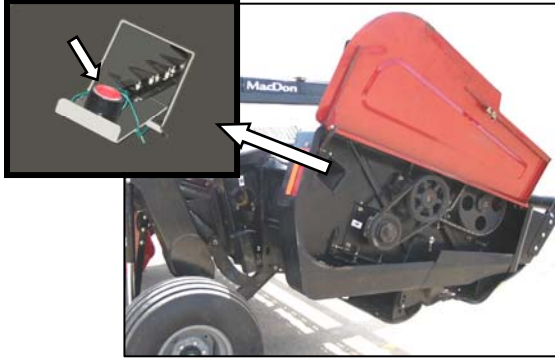

- b. Spare sickles with knife head for double knife headers may be stored inside the lean bar. The LH sickle is stored at the LH end of the lean bar, and the RH sickle is stored at the right end of the lean bar.

To remove the sickle, proceed as follows:



CAUTION

Stop engine, and remove key from ignition before leaving Operator's seat for any reason. A child or even a pet could engage an idling machine.

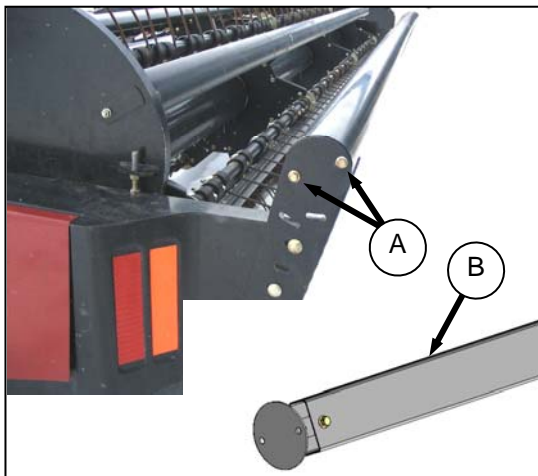

1. Remove bolts (A) from lean bar end cap.
2. Pull out end cap and plastic storage tube assembly (B) with the sickle inside.
3. Slide knife from storage tube (B).
4. Replace storage tube inside lean bar.
5. Re-install bolts (A), and tighten.

7.8.7 Sickle Guards

Check daily that guards are aligned to obtain proper shear cut between sickle section and guard. Sickle sections should contact shear surface of each guard.

7.8.7.1 Guard Alignment

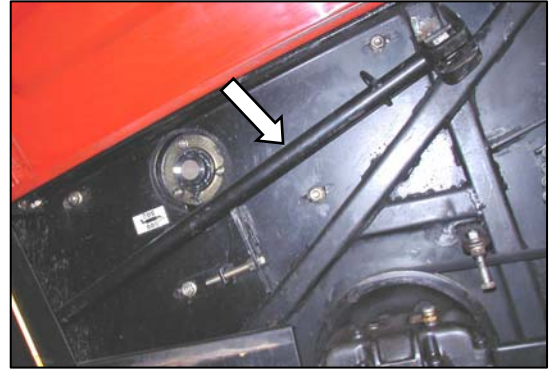

- a. Retrieve tool from LH side of header.



DOWNWARD ADJUSTMENT

- b. To adjust guard tips downward, position tool as shown above, and push down.



UPWARD ADJUSTMENT

- c. To adjust guard tips upward, position tool as shown above, and pull up.

(continued next page)

SECTION 7 MAINTENANCE AND SERVICING

TIP: If trouble is encountered cutting tangled, or fine-stemmed material, replace guards with stub guards.

If material is tough to cut, install stub guards with top guard and adjuster plate. A stub guard conversion kit for the header/mower conditioner is available from your Dealer. Refer to Section 9.5 STUB GUARD CONVERSION KIT.

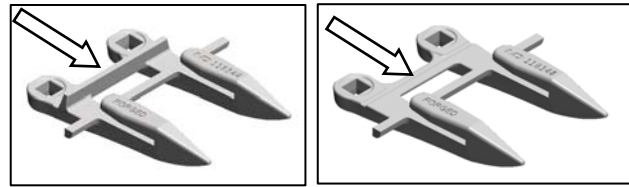

NORMAL

DRIVE SIDE

7.8.7.2 Guard Replacement

Check daily that guards are firmly bolted to the cutterbar, and are not worn or broken. Replace as required. A worn or broken guard can be replaced without removing sickle from cutterbar.

7.8.7.2.1 Pointed Guard Replacement: Single Knife



CAUTION

Stop engine, and remove key from ignition before leaving Operator's seat for any reason. A child or even a pet could engage an idling machine.

- Stroke the sickle so that sickle sections are spaced midway between the guards.

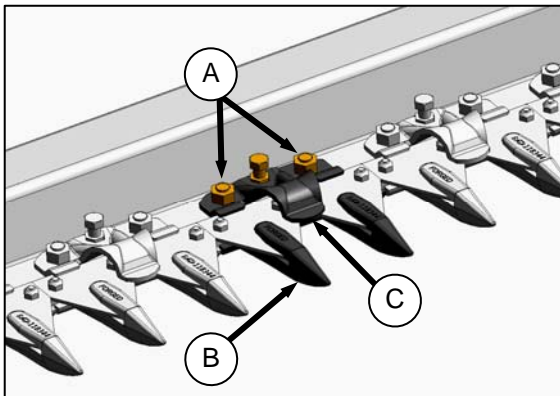

- Remove two nuts (A), and carriage bolts that attach guard (B) and hold-down (C) (if applicable) to the cutterbar.
- Remove the guard and the hold-down.
- Position new guard on cutterbar, and install carriage bolts.

IMPORTANT

The second, third, and fourth outboard guards on drive side of the header do not have a support. Ensure that the proper replacement is installed.

- Install hold-down, and secure with nuts. Tighten nuts to 50 ft·lbf (68 N·m).
- Check and adjust clearance between hold-down and sickle. Refer to Section 7.8.8 Sickle Hold-Downs.

SECTION 7 MAINTENANCE AND SERVICING

7.8.7.2.2 Pointed Guard Replacement: Double Knife

Refer to previous section for standard guard replacement.

The guard near the center of the double knife header, where the two sickles overlap, requires a slightly different replacement procedure.

IMPORTANT

Replace adjacent guards when replacing center guard.

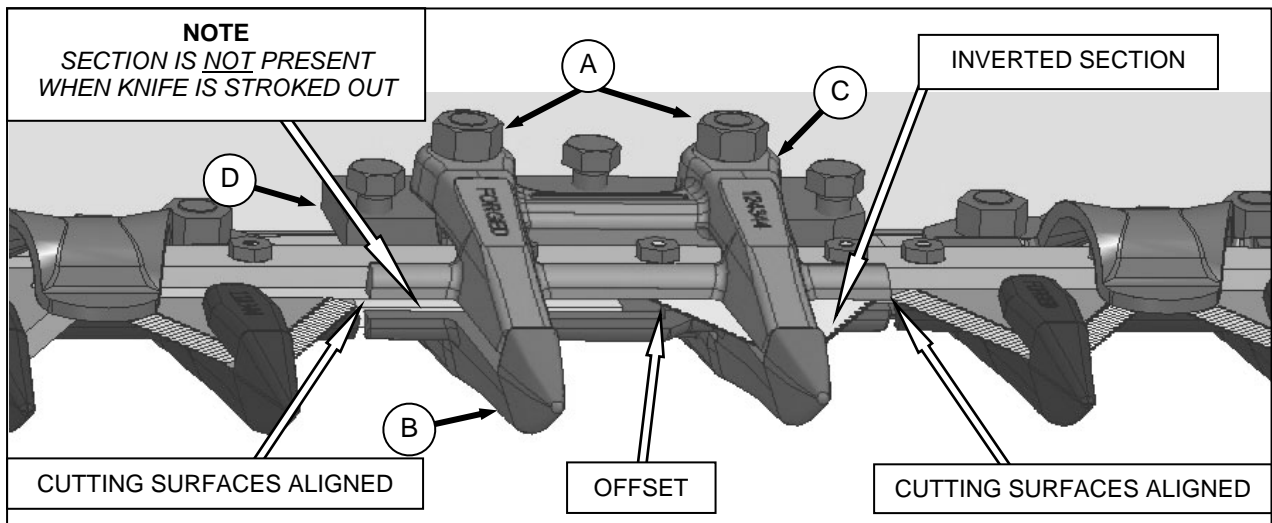

CENTER POINTED GUARD AND HOLD-DOWN (SICKLES STROKED FULLY OUT)

- Remove two nuts (A) and bolts that attach center guard (B) and top guide (C) to cutterbar.
- Remove guard and top guide (C), and adjuster bar (D).

IMPORTANT

Ensure center guard (B) has offset cutting surfaces. See illustrations.

NOTE

Top guide (C) must accommodate the two overlapping knives at center guard (B) location on double knife header. Ensure replacement is correct part.

IMPORTANT

Ledger surfaces of center and adjacent guards must be vertically aligned to avoid interference with sickle sections.

- Position replacement center guard (B), adjuster bar (D), top guide (C), and install bolts. Do not tighten fully.
- Check and adjust clearance between top guide (C) and sickle. Refer to *Section 7.8.8 Sickle Hold-Downs*.

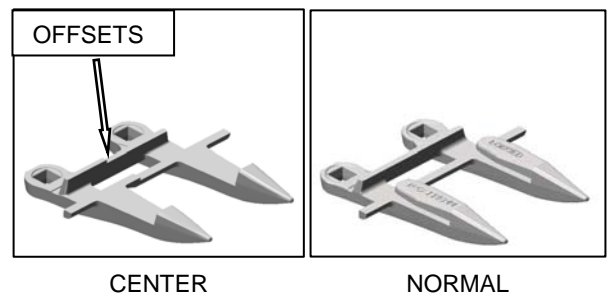

SECTION 7 MAINTENANCE AND SERVICING

7.8.7.2.3 Stub Guard Replacement: Single Knife

Stub guards, complete with top guides and adjuster plates are designed to cut tough crops.



CAUTION

Stop engine, and remove key from ignition before leaving Operator's seat for any reason. A child or even a pet could engage an idling machine.

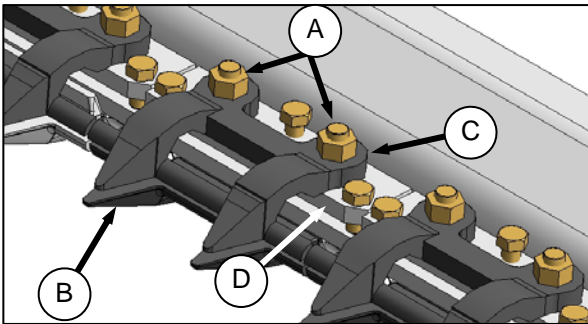

- Remove two nuts (A) and bolts that attach guard (B) and top guide (C) to cutterbar.
- Remove guard, top guide, and adjuster bar (D).
- Position replacement guard (B), adjuster bar (D), top guide (C), and install bolts and nuts (A). Do not tighten.

IMPORTANT

Note position of mitre on adjuster bar (D). Bar should be re-installed in same position. Mitres should not be adjacent to each other.

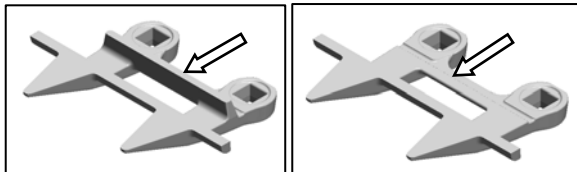

NORMAL

DRIVE SIDE

IMPORTANT

The second, third, and fourth outboard guards on drive side of the header do not have a support. Ensure that the proper replacement is installed.

- Check and adjust clearance between top guide and sickle. Refer to *Section 7.8.8 Sickle Hold-Downs*.

SECTION 7 MAINTENANCE AND SERVICING

7.8.7.2.4 Stub Guard Replacement: Double Knife

Refer to previous section for typical guard replacement.

The guard near the center of the double knife header, where the two sickles overlap, requires a slightly different replacement procedure.

IMPORTANT

Replace adjacent guards when replacing center guard.

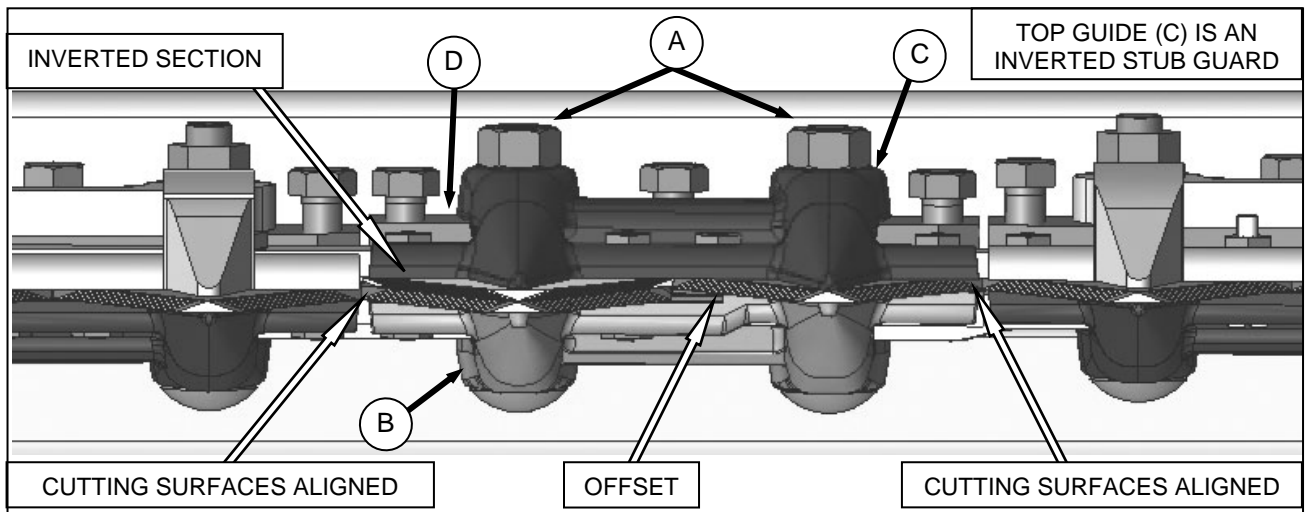

CENTER STUB GUARD AND HOLD-DOWN (SICKLES STROKED FULLY IN)

- Remove two nuts (A) and bolts that attach center guard (B) and top guide (C) to cutterbar.
- Remove guard and top guide and adjuster bar (D).

IMPORTANT

Ensure center guard (B) has offset cutting surfaces. See illustration.

NOTE

Top guide (C) (which is an inverted stub guard) must accommodate the two overlapping knives at center guard location on double knife header. Ensure replacement is correct part.

IMPORTANT

Ledger surfaces of center and adjacent guards must be vertically aligned to avoid interference with sickle sections.

- Position replacement guard (B), adjuster bar (D), top guide (C), and install bolts and nuts (A). Do not tighten.
- Check and adjust clearance between hold-down and sickle. Refer to *Section 7.8.8 Sickle Hold-Downs*.

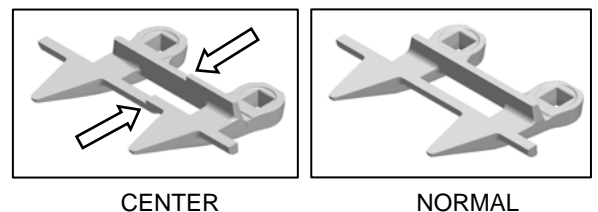

CENTER

NORMAL

SECTION 7 MAINTENANCE AND SERVICING

7.8.8 Sickles Hold-Downs

Check daily that sickle hold-downs are set to prevent sickle sections from lifting off guards, but still permit sickle to slide without binding.

NOTE

Guards should be aligned prior to adjusting hold-downs.



CAUTION

Stop engine, and remove key from ignition before leaving Operator's seat for any reason. A child or even a pet could engage an idling machine.

7.8.8.1 Sickle Hold-Down Adjustment: Pointed Guards

Single Knife

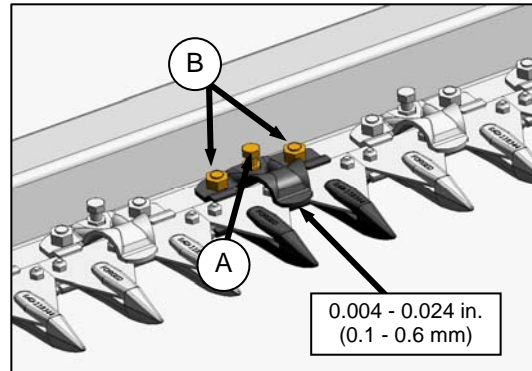

- Turn adjuster bolt (A). Using a feeler gauge, clearance from hold-down to sickle section should be 0.004–0.024 in. (0.1–0.6 mm).

NOTE

For larger adjustments, it may be necessary to loosen bolts (B), turn adjuster bolt (A), and then re-tighten nuts (B).

Double Knife

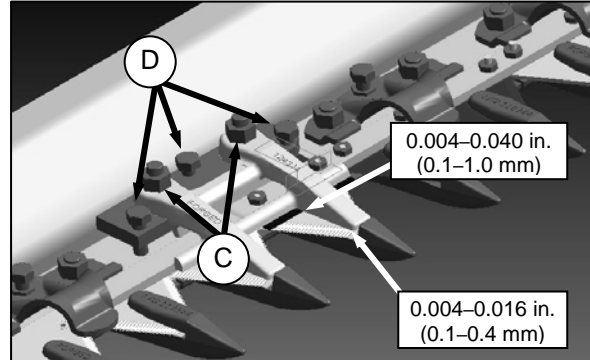

- Torque nuts (C) to 35 ft·lbf (46 N·m).
- Turn adjuster bolts (D). Using feeler gauge, clearance from hold-down to sickle section should be 0.004–0.016 in. (0.1–0.4 mm) at the guide tip, and 0.004–0.040 in. (0.1–1.0 mm) at rear of guide.
- Torque nuts (C) to 53 ft·lbf (72 N·m).
- After adjusting all hold-downs, run header at a low engine speed, and listen for noise due to insufficient clearance. Insufficient clearance will also result in overheating of the sickle and guards.

SECTION 7 MAINTENANCE AND SERVICING

7.8.8.2 Sickles Hold-Down Adjustment: Stub Guards

Single Knife

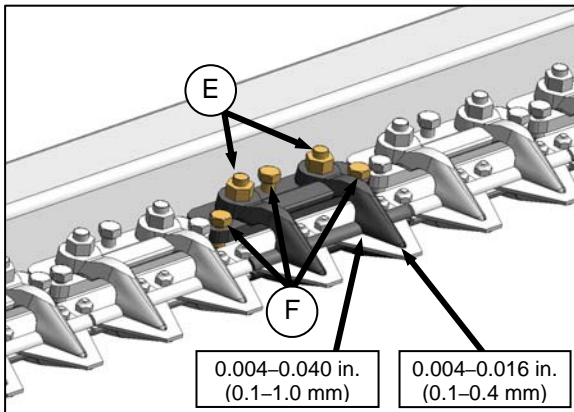

- Torque nuts (E) to 35 ft·lbf (46 N·m).
- Turn adjuster bolts (F). Using a feeler gauge, clearance from hold-down to sickle section should be 0.004–0.016 in. (0.1–0.4 mm) at the guard tip, and 0.004–0.040 in. (0.1–1.0 mm) at rear of guide.
- Torque nuts (E) to 53 ft·lbf (72 N·m).

Double Knife

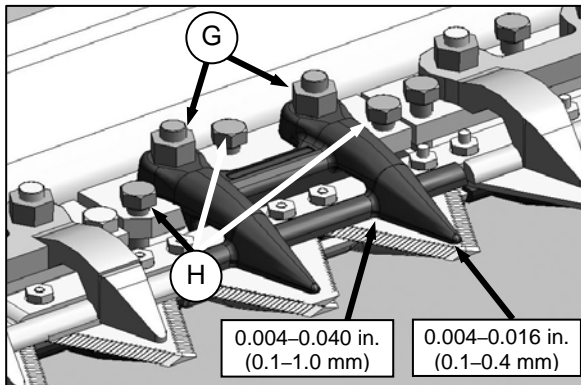

- Torque nuts (G) to 35 ft·lbf (46 N·m).
- Turn adjuster bolts (H). Using a feeler gauge, clearance from hold-down to sickle section should be 0.004–0.016 in (0.1–0.4 mm) at the guide tip, and 0.004–0.040 in. (0.1–1.0 mm) at rear of guide.
- Torque nuts (G) to 53 ft·lbf (72 N·m).
- After adjusting all hold-downs, run header at a low engine speed, and listen for noise due to insufficient clearance. Insufficient clearance will also result in overheating of the sickle and guards.

SECTION 7 MAINTENANCE AND SERVICING

7.8.9 Sickle Drive Belt: A30-S



CAUTION

Stop engine, and remove key from ignition before leaving Operator's seat for any reason. A child or even a pet could engage an idling machine.

7.8.9.1 Tension Adjustment: Sickle Drive Belt - A30-S

IMPORTANT

To prolong belt and drive life, do not over-tighten belts.

- Open LH endshield.

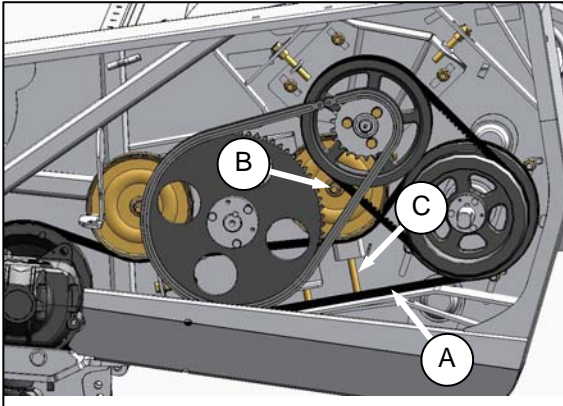

- Loosen nut (B) securing idler pulley.
- Loosen jam nut on adjuster bolt (C).
- Turn adjuster bolt (C) to move idler until a force of 20 lbf (80 N) deflects belt (A) 1/4 in. (6 mm) at mid-span.
- Tighten jam nut at (C) and nut (B) on idler pulley.
- Close shield.
- Re-adjust tension of a new belt after a short run-in period (about 5 hours).

7.8.9.2 Removal: Sickle Drive Belt - A30-S

- Open LH endshield.

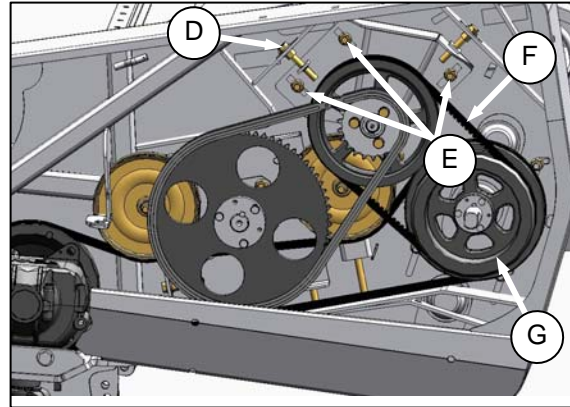

- Loosen jam nut on adjuster bolt (D).
- Loosen three bolts (E).
- Turn adjuster bolt (D) to loosen auger drive belts (F) so they can be slipped off pulley (G).

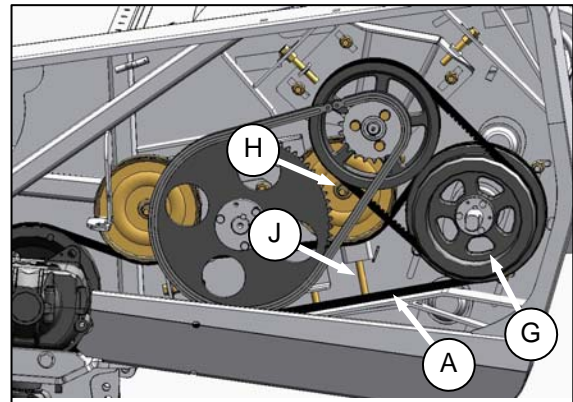

- Loosen nut (H) securing idler pulley.
- Loosen jam nut on adjuster bolt (J).
- Turn adjuster bolt (J) so that sickle drive belt (A) can be slipped off pulley (G).

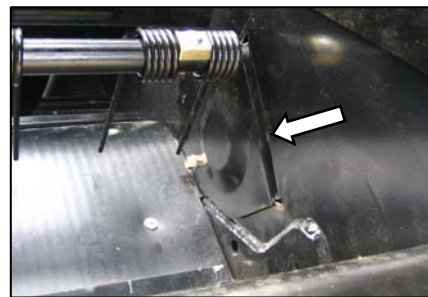

- Remove bolt-in plate in LH endsheet at sickle drive box.
- Slip belt off sickle drive box pulley, and route belt through this hole to remove it.

SECTION 7 MAINTENANCE AND SERVICING

7.8.9.3 Installation: A30-S Sickle Drive Belt

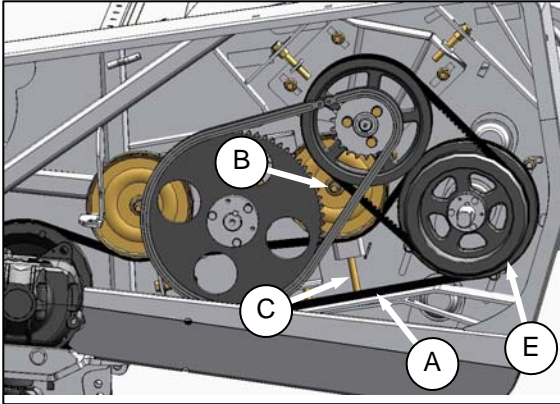

- a. Route sickle drive belt (A) through opening in endsheet onto sickle drive box pulley and sickle drive pulley (E) as shown.

NOTE

When installing new belt, *never pry belt over pulley. Be sure idler is fully loosened, then tension belt.*

- b. Turn adjuster bolt (C) to move idler until a force of 20 lbf (80 N) deflects belt (A) 1/4 in. (6 mm) at mid-span.
- c. Tighten idler bolt (B).

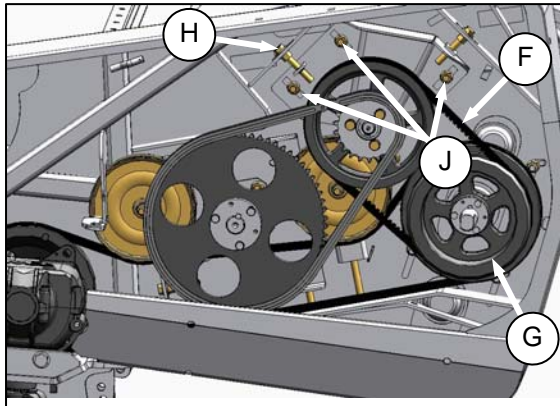

- d. Position belts (F) on pulley (G) as shown.
- e. Turn adjuster bolt (H) so that each belt deflects 3/16 in. (4 mm) at mid-span when a load of 8–12 lbf (35–40 N) is applied to each belt.
- f. Tighten bolts (J) and jam nut on (H).

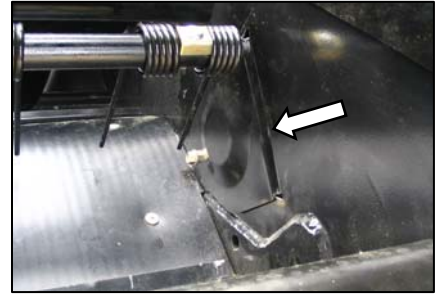

- g. Install bolt-in plate in LH endsheet at sickle drive box, and close endshield.
- h. Re-adjust tension of a new belt after a short run-in period (about 5 hours).

SECTION 7 MAINTENANCE AND SERVICING

7.8.10 Sickle Drive Belts: A30-D

7.8.10.1 Tension Adjustment: LH Sickle Drive Timing Belt - A30-D

IMPORTANT

To prolong belt and drive life, do not over-tighten belts.



CAUTION

Stop engine, and remove key from ignition before leaving Operator's seat for any reason. A child or even a pet could engage an idling machine.

- a. Open LH endshield.

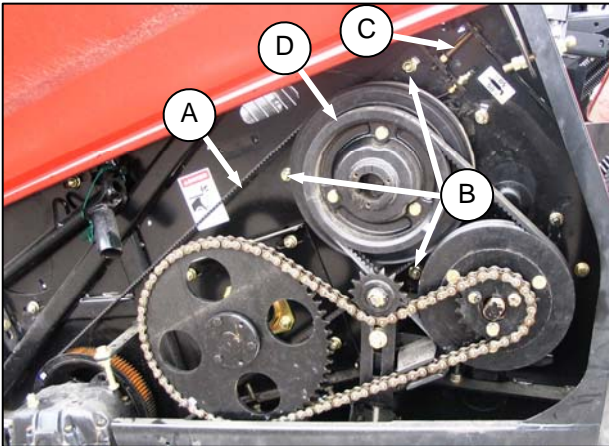

- b. Loosen three nuts (B).
- c. Loosen jam nut on adjuster bolt (C).
- d. Turn adjuster bolt (C) to move pulley (D) until a force of 5–6.5 lbf (22–30 N) deflects belt (A) 0.55 in. (14 mm) at mid-span.
- e. Tighten jam nut at (C), and three nuts (B).
- f. Close endshield.
- g. Re-adjust tension of a new belt after a short run-in period (about 5 hours).

7.8.10.2 Removal: LH Sickle Drive Belts: A30-D

- a. Open LH endshield.

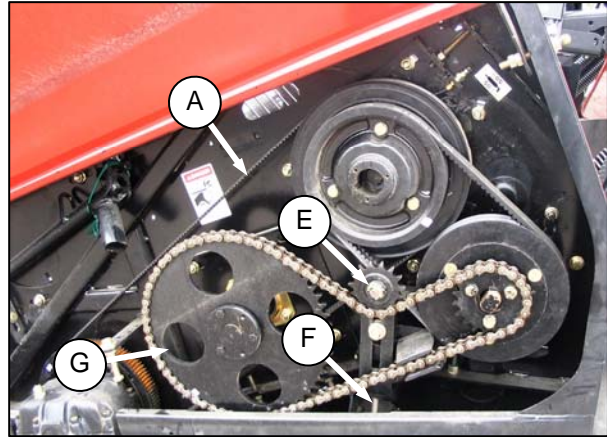

- b. Loosen nut (E) on idler sprocket.
- c. Turn adjuster bolt (F) to loosen chain so that it can be removed from large sprocket (G).

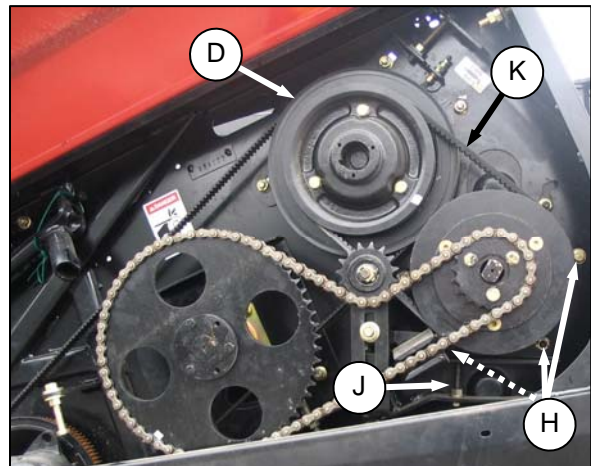

- d. Loosen nuts (H), and jam nut on adjuster bolt (J).
- e. Turn adjuster bolt (J) to loosen V-belts (K) so that belts can be slipped off pulley (D).

(continued next page)

SECTION 7 MAINTENANCE AND SERVICING

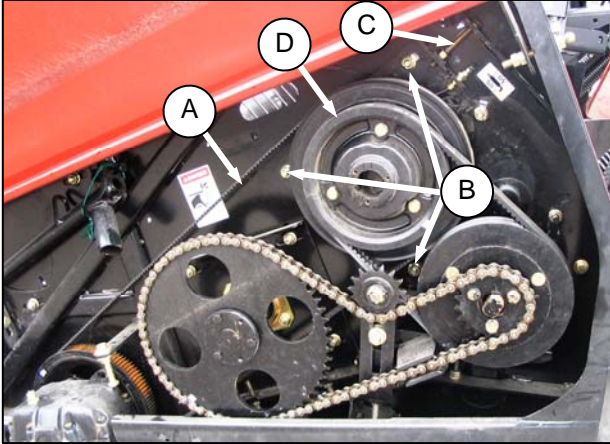

- f. Loosen three nuts (B).
- g. Loosen jam nut on adjuster bolt (C), and turn adjuster bolt (C) so that sickle drive belt (A) can be slipped off pulley (D).

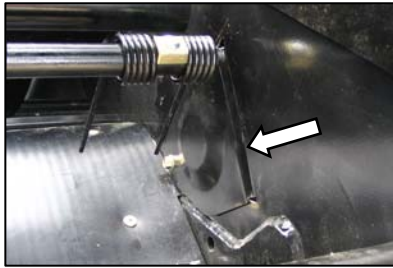

- h. Remove bolt-in plate in LH endsheet at sickle drive box.
- i. Slip belt off sickle drive box pulley, and route belt through this hole to remove it.

SECTION 7 MAINTENANCE AND SERVICING

7.8.10.3 Installation: LH Sickle Drive Belts: A30-D



CAUTION

Stop engine, and remove key from ignition before leaving Operator's seat for any reason. A child or even a pet could engage an idling machine.

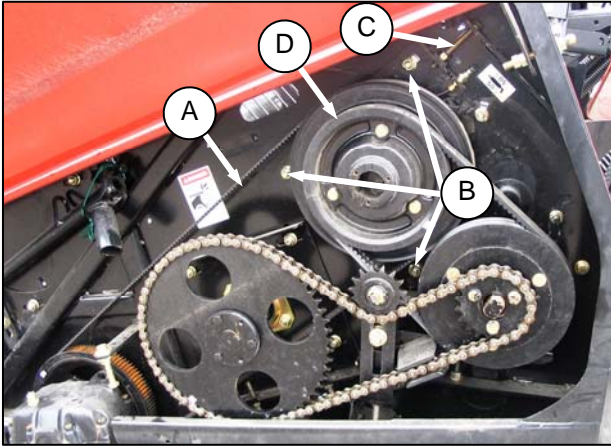

- a. Route sickle drive belt (A) through opening in endsheet onto sickle drive box pulley and sickle drive pulley (D) as shown.

NOTE

When installing new belt, never pry belt over pulley. Be sure idler is fully loosened, then tension belt.

IMPORTANT

To prolong belt and drive life, do not over-tighten belts.

- b. Turn adjuster bolt (C) to move pulley (D) until a force of 5–6.5 lbf (22–30 N) deflects belt (A) 0.55 in. (14 mm) at mid-span.
- c. Tighten jam nut at (C), and three nuts (B).

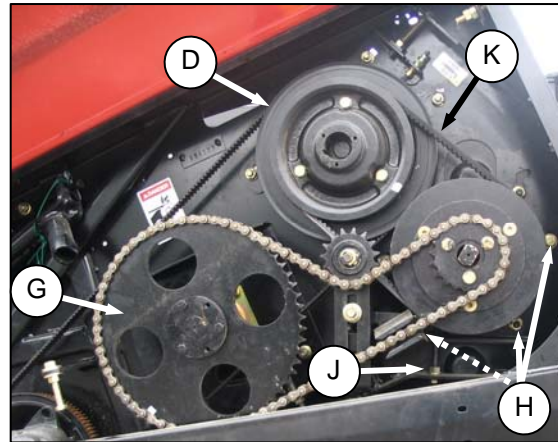

- d. Re-position V-belts (K) on pulley (D)
- e. Turn adjuster bolt (J) to move drive pulley until a force of 8–12 lbf (35–50 N) applied at mid-span on each belt (K) deflects each belt 0.16 in. (4 mm).
- f. Tighten jam nut at (J), and three nuts (H).
- g. Re-position chain on large sprocket (G).

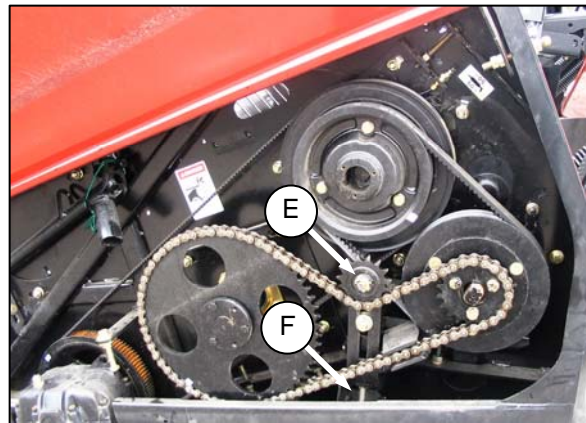

- h. Turn adjuster bolt (F) to tighten chain to give 0.2 in. (5 mm) slack at mid-span. Tighten nut (E) on idler sprocket.
- i. Rotate auger and check chain for slack at tightest point. Re-adjust position of idler sprocket to achieve required slack.

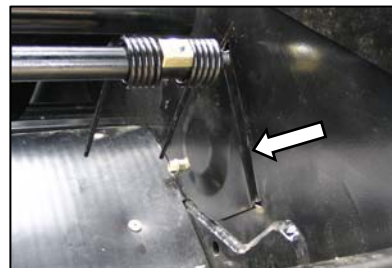

- j. Install bolt-in plate in LH endsheet at sickle drive box, and close endshield.
- k. Re-adjust tension of a new belt after a short run-in period (about 5 hours).

SECTION 7 MAINTENANCE AND SERVICING

7.8.10.4 Tension Adjustment: RH Sickle Drive Timing Belt - A30-D

IMPORTANT

To prolong belt and drive life, do not over-tighten belts.



CAUTION

Stop engine, and remove key from ignition before leaving Operator's seat for any reason. A child or even a pet could engage an idling machine.

- a. Open RH endshield.

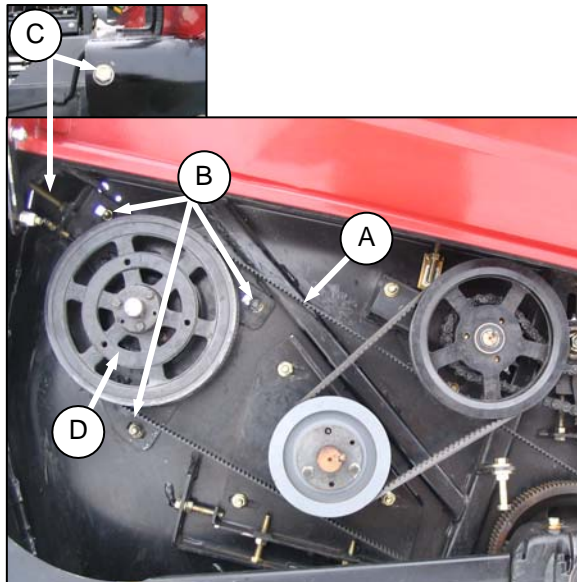

- b. Loosen three nuts (B), and jam nut on adjuster bolt (C).
- c. Turn adjuster bolt (C) to move pulley (D) until a force of 5–6.5 lbf (22–30 N) applied at mid-span deflects belt (A) 0.55 in. (14 mm).
- d. Tighten jam nut at (C), and three nuts (B).
- e. Close endshield.
- f. Re-adjust tension of a new belt after a short run-in period (about 5 hours).

7.8.10.5 Removal: RH Sickle Drive Timing Belt: A30-D

- a. Open shield on header RH side.

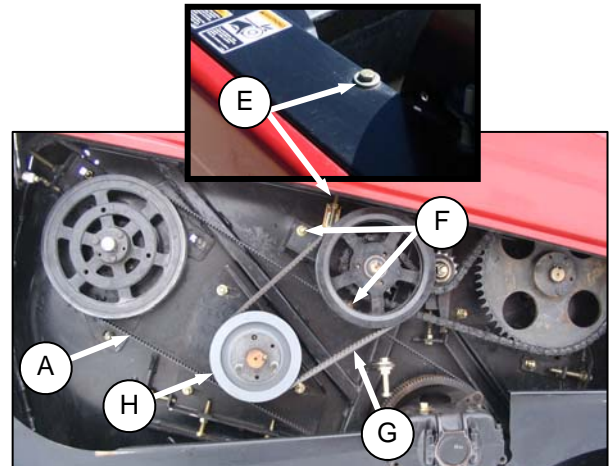

- b. Loosen jam nut on adjuster bolt (E), and nuts (F).
- c. Turn adjuster bolt (E) to loosen reel drive V-belts (G), and remove belts from pulley (H).
- d. Loosen three nuts (B), and jam nut on adjuster bolt (C).
- e. Turn adjuster bolt (C) so that sickle drive belt (A) can be slipped off pulley (D).

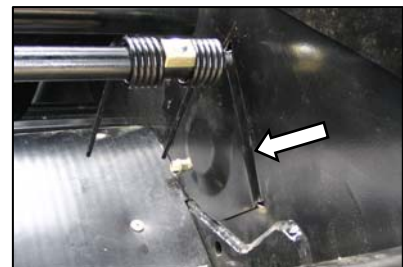

- f. Remove bolt-in plate in LH endsheet at sickle drive box.
- g. Slip belt off sickle drive box pulley, and route belt through this hole to remove it.

SECTION 7 MAINTENANCE AND SERVICING

7.8.10.6 Installation: RH Sickle Drive Timing Belt - A30-D



CAUTION

Stop engine, and remove key from ignition before leaving Operator's seat for any reason. A child or even a pet could engage an idling machine.

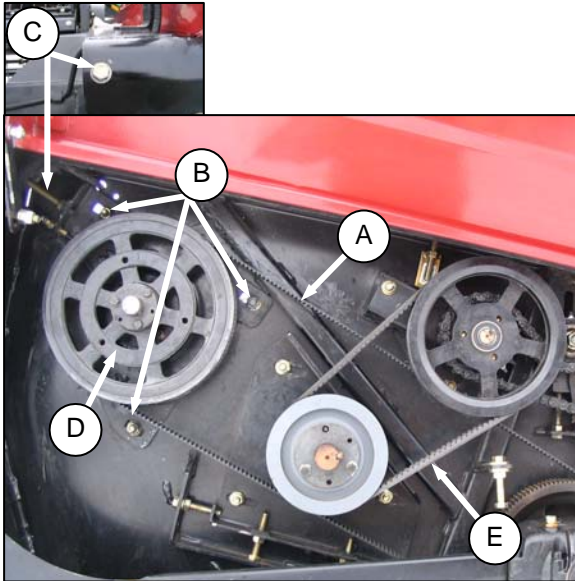

- a. Route sickle drive belt (A) through opening in endsheet onto sickle drive box pulley and sickle drive pulley (D).

NOTE

When installing new belt, never pry belt over pulley. Be sure adjusting screw is fully loosened, then tension belt.

- b. Turn adjuster bolt (C) to move pulley (D) until a force of 5–6.5 lbf (22–30 N) applied at mid-span deflects belt (A) 0.55 in. (14 mm).
- c. Tighten jam nut at (C), and three nuts (B).
- d. Position V-belts (E) on pulleys.

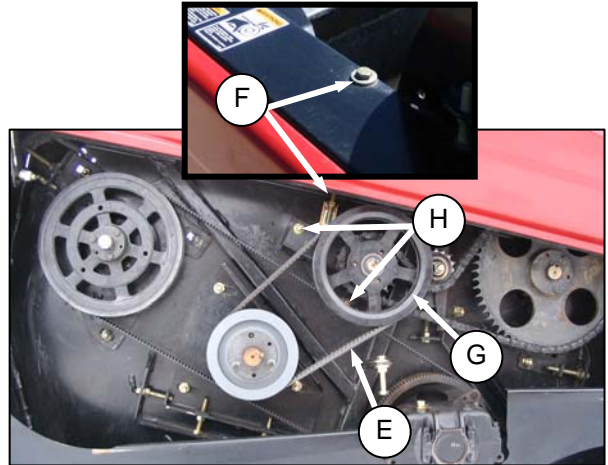

- e. Turn adjuster bolt (F) to move pulley (G) so that each belt (E) deflects 3/16 in. (4 mm) when a load of 8–12 lbf (35–40 N) is applied to each belt at mid-span.
- f. Tighten jam nut on adjuster bolt (F), and nuts (H).

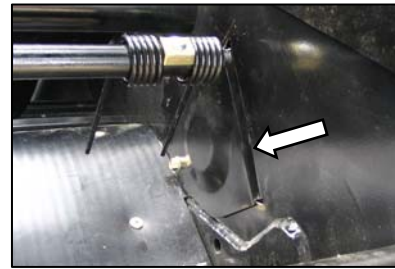

- g. Install bolt-in plate in RH endsheet at sickle drive box.
- h. Close endshield.
- i. Re-adjust tension of a new belt after a short run-in period (about 5 hours).

SECTION 7 MAINTENANCE AND SERVICING

7.8.11 Sickle Drive Belts: A40-D

7.8.11.1 Tension Adjustment: LH Sickle Drive Belts - A40-D

IMPORTANT

To prolong belt and drive life, do not over-tighten belts.

Timing Belt



CAUTION

Stop engine, and remove key from ignition before leaving Operator's seat for any reason. A child or even a pet could engage an idling machine.

- Open shield on LH side of the header.

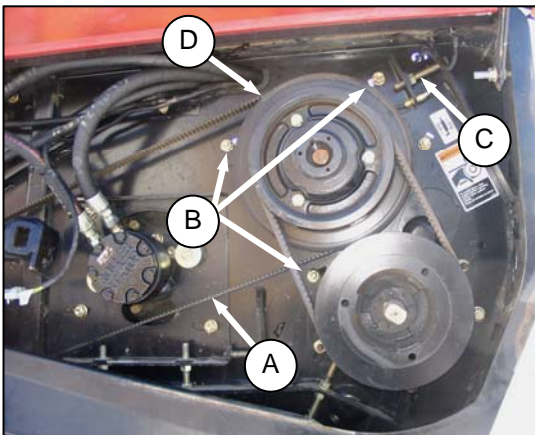

- Loosen three nuts (B), and jam nut on adjuster bolt (C).
- Turn adjuster bolt (C) to move pulley (D) until a force of 5–6.5 lbf (22–30 N) applied at mid-span deflects belt (A) 0.55 in. (14 mm).
- Tighten jam nut at (C), and three nuts (B).
- Re-adjust tension of a new belt after a short run-in period, (about 5 hours).

Double V-Belts

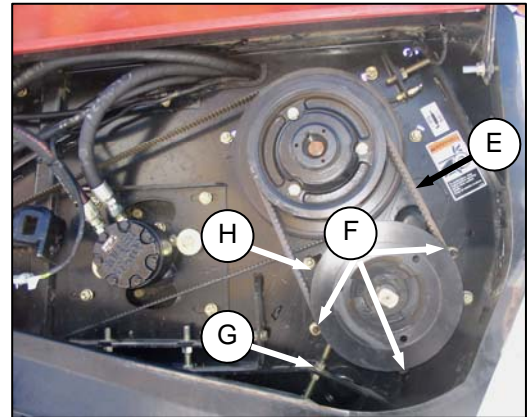

- Loosen three nuts (F), and jam nut on adjuster bolt (G).
- Turn adjuster bolt (G) to move pulley (H) until a force of 8–12 lbf (35–50 N) applied to each belt at mid-span deflects each belt (E) 0.16 in. (4 mm).
- Tighten jam nut at (G), and three nuts (F).
- Close endshield.
- Re-adjust tension of a new belt after a short run-in period (about 5 hours).

7.8.11.2 Removal: LH Sickle Drive Belts - A40-D

Double V-Belts

- Open shield on LH side of the header.

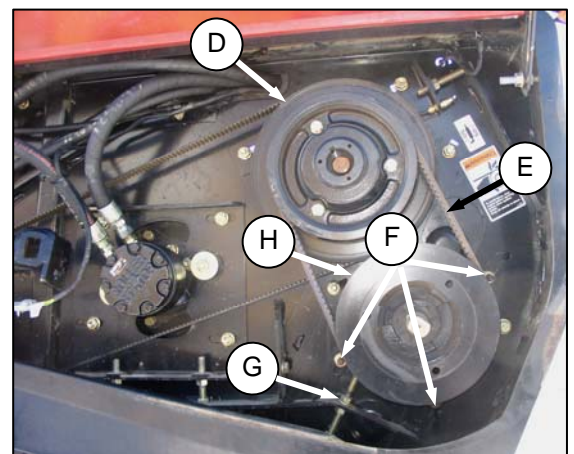

- Loosen three nuts (F), and jam nut on adjuster bolt (G).
- Turn adjuster bolt (G) so that drive belts (E) can be slipped off pulleys (D) and (H).

(continued next page)

SECTION 7 MAINTENANCE AND SERVICING

Timing Belt

- Remove double V-belts as per previous page.

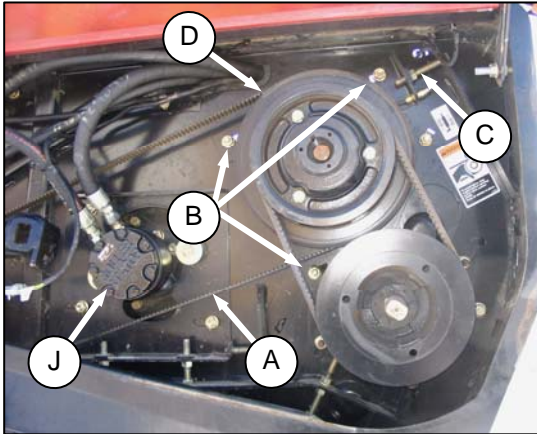

- Disconnect hoses from auger drive motor (J). Protect hose ends and motor ports with clean, lint-free cloths or clean plastic bags.
- Loosen three nuts (B), and jam nut on adjuster bolt (C).
- Turn adjuster bolt (C) so that sickle drive belt (A) can be slipped off pulley (D).

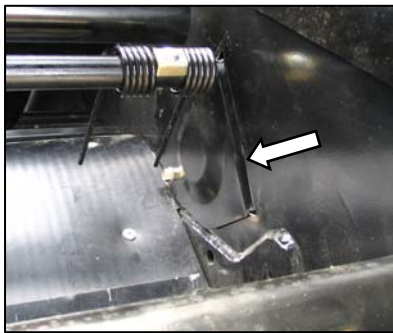

- Remove bolt-in plate in LH endsheet at sickle drive box.
- Slip belt off sickle drive box pulley, and route belt through this hole to remove it.

7.8.11.3 Installation: LH Sickle Drive Timing Belts - A40-D



CAUTION

Stop engine, and remove key from ignition before leaving Operator's seat for any reason. A child or even a pet could engage an idling machine.

Timing Belt

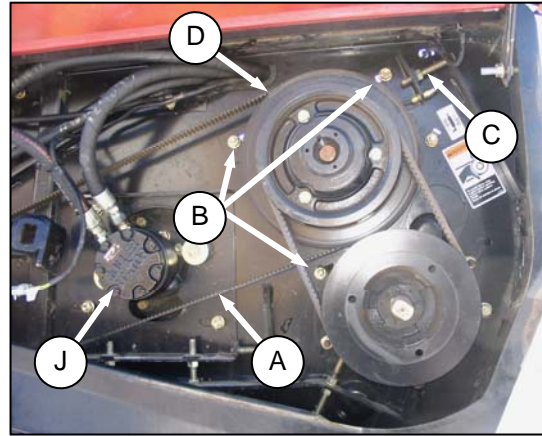

- Route sickle drive belt (A) through opening in endsheet onto sickle drive box pulley and sickle drive pulley (D) as shown.

NOTE

When installing new belt, never pry belt over pulley. Be sure adjusting screw is fully loosened, then tension belt.

IMPORTANT

To prolong belt and drive life, do not over-tighten belts.

- Turn adjuster bolt (C) to move pulley (D) until a force of 5–6.5 lbf (22–30 N) deflects belt (A) 0.55 in. (14 mm) at mid-span.
- Tighten jam nut at (C), and three nuts (B).
- Re-connect hoses onto hydraulic motor (J).
- Re-adjust tension of a new belt after a short run-in period (about 5 hours).

(continued next page)

SECTION 7 MAINTENANCE AND SERVICING

Double V-Belts

IMPORTANT

Belts are a matched set. Replace both drive belts even if only one needs replacing.

NOTE

When installing new belt, never pry belt over pulley. Be sure adjusting screw is fully loosened, then tension belt.

IMPORTANT

To prolong belt and drive life, do not over-tighten belts.

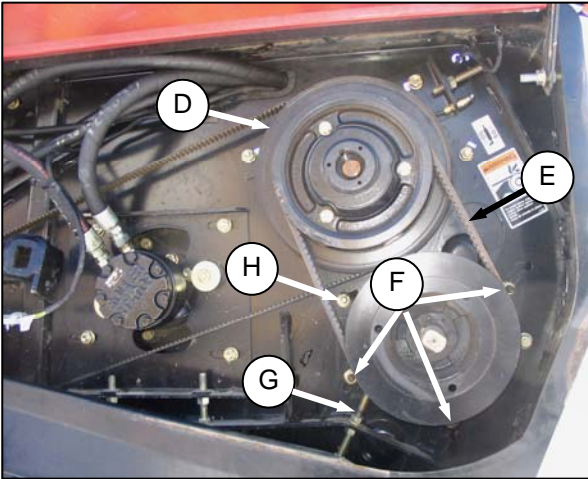

- Slip belts (E) onto pulleys (H) and (D).
- Turn adjuster bolt (G) to move pulley (H) until a force of 8–12 lbf (35–50 N) applied at mid-span to each belt deflects each belt (E) 0.16 in. (4 mm).
- Tighten jam nut at (G), and three nuts (F).
- Re-adjust tension of a new belt after a short run-in period (about 5 hours).

7.8.11.4 Tension Adjustment: RH Sickle Drive Belt - A40-D

IMPORTANT

To prolong belt and drive life, do not over-tighten belts.



CAUTION

Stop engine, and remove key from ignition before leaving Operator's seat for any reason. A child or even a pet could engage an idling machine.

- Open RH endshield.

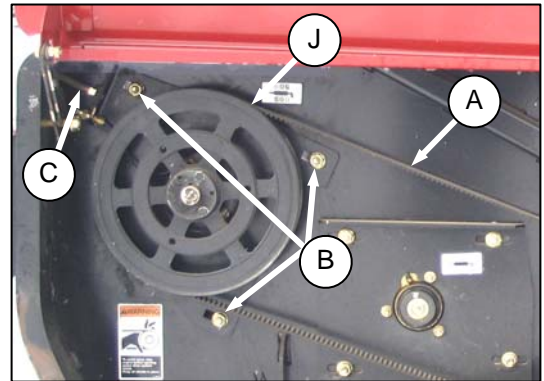

- Loosen three nuts (B), and jam nut on adjuster bolt (C).
- Turn adjuster bolt (B) to move pulley (J) until a force of 5–6.5 lbf (22–30 N) deflects belt (A) 0.55 in. (14 mm) at mid-span.
- Tighten jam nut at (C), and three nuts (B).
- Re-adjust tension of a new belt after a short run-in period (about 5 hours).

SECTION 7 MAINTENANCE AND SERVICING

7.8.11.5 Removal: RH Sickle Drive Belt - A40-D



CAUTION

Stop engine, and remove key from ignition before leaving Operator's seat for any reason. A child or even a pet could engage an idling machine.

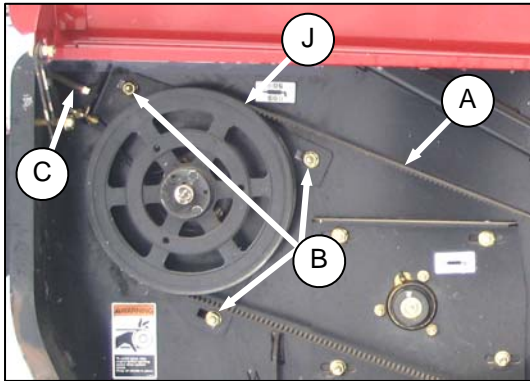

- Loosen three nuts (B), and jam nut on adjuster bolt (C).
- Turn adjuster bolt (C) so that sickle drive belt (A) can be slipped off pulley (J).

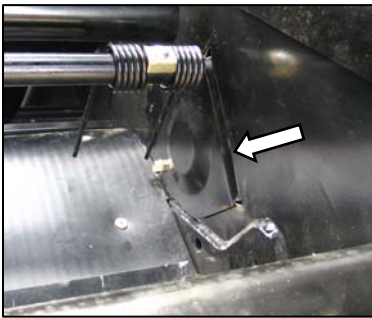

- Remove bolt-in plate in LH endsheet at sickle drive box.
- Slip belt off sickle drive box pulley, and route belt through this hole to remove it.

7.8.11.6 Installation: RH Sickle Drive Belt - A40-D

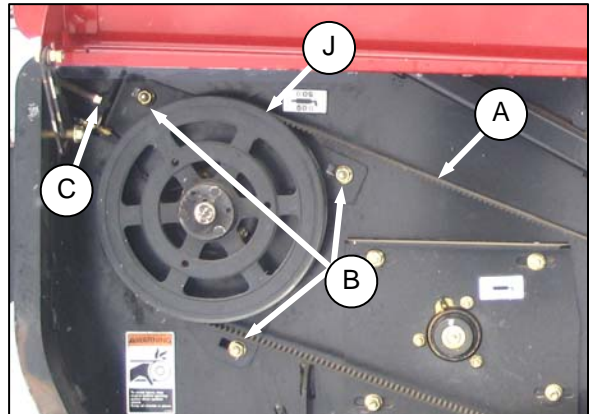

- Route sickle drive belt (A) through opening in endsheet onto sickle drive box pulley and sickle drive pulley (J) as shown.

NOTE

When installing new belt, never pry belt over pulley. Be sure adjusting screw is fully loosened, then tension belt.

IMPORTANT

To prolong belt and drive life, do not over-tighten belts.

- Turn adjuster bolt (C) to move pulley (J) until a force of 5–6.5 lbf (22–30 N) deflects belt (A) 0.55 in. (14 mm) at mid-span.
- Tighten jam nut at (C), and three nuts (B).

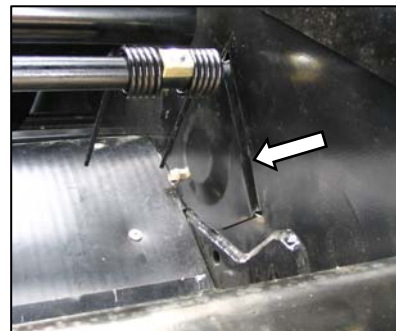

- Install bolt-in plate in LH endsheet at sickle drive box, and close endshield.
- Re-adjust tension of a new belt after a short run-in period (about 5 hours).

SECTION 7 MAINTENANCE AND SERVICING

7.8.12 Sickle Drive Timing Adjustment

Double knife A30-D and A40-D Auger Headers require that the sickles are properly timed to move in opposite directions.



CAUTION

Stop engine, and remove key from ignition before leaving Operator's seat for any reason. A child or even a pet could engage an idling machine.

- Remove the right side sickle drive belt. Refer to Section 7.8.10.5 Removal: RH Sickle Drive Timing Belt: - A30-D, or Section 7.8.11.5 Removal: RH Sickle Drive Belt - A40-D.

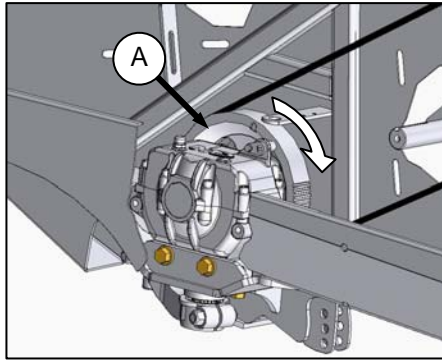

- Rotate LH side sickle drive box driven pulley (A) clockwise until LH side sickle (B) is at the center of the inboard stroke (moving towards center of header).

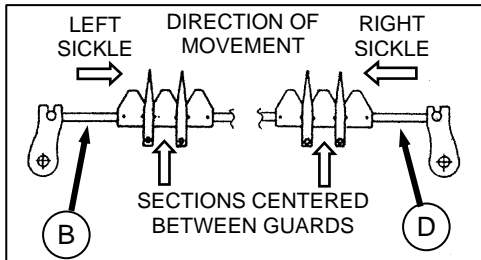

NOTE

Center stroke is when the sickle sections are centered between guard points as shown.

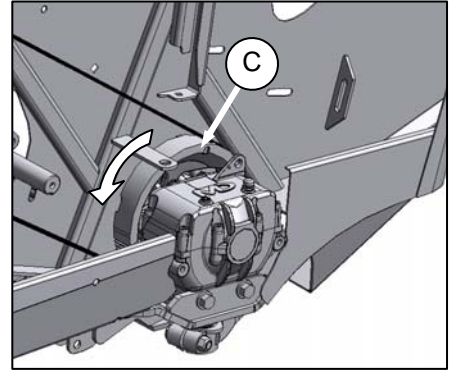

- Rotate right side sickle drive box pulley (C) counterclockwise until right side sickle (D) is at the center of the inboard stroke.
- Install right side sickle drive box drive belt and tension. Refer to Section 7.8.10.6 Installation: RH Sickle Drive Belt - A30-D, or 7.8.11.6 Installation: RH Sickle Drive Belt - A40-D.

IMPORTANT

To maintain timing, sickle drive box driver and driven pulleys must not rotate as the belt is tightened.

- Check that timing belts are properly seated in the grooves on both driver and driven pulleys.

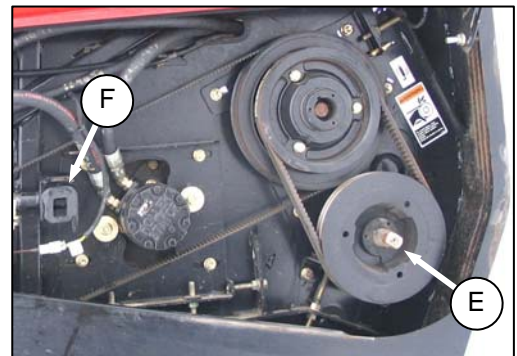

- Check for correct sickle timing by rotating driveshaft (E) slowly with the unplugging wrench (F), and observe sickles where they overlap at the center of the header.

IMPORTANT

Sickles must move in opposite directions, and must begin moving at exactly the same time.

(continued next page)

SECTION 7 MAINTENANCE AND SERVICING

- g. If timing is off, proceed as follows:
1. Loosen right side timing belt sufficiently to allow skipping the belt one or more teeth as required. Refer to Section 7.8.10.4 Tension Adjustment: RH Sickle Drive Timing Belt - A30-D, or 7.8.11.4 Tension Adjustment: RH Sickle Drive Belt - A40-D.

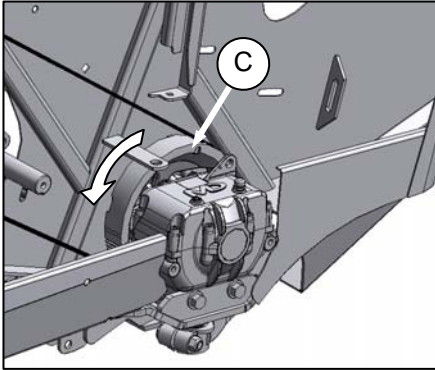

2. **If RIGHT SICKLE leads LEFT SICKLE,** rotate RIGHT HAND driven pulley (C) clockwise.
3. **If RIGHT SICKLE lags LEFT SICKLE,** rotate RIGHT HAND driven pulley (C) counterclockwise.
4. Tighten right side timing belt. Refer to Section 7.8.10.4 Tension Adjustment: RH Sickle Drive Timing Belt - A30-D, or 7.8.11.4 Tension Adjustment: RH Sickle Drive Belt - A40-D.

SECTION 7 MAINTENANCE AND SERVICING

7.8.13 Sickle Drive Box

7.8.13.1 Mounting Bolts



CAUTION

Stop engine, and remove key from ignition before leaving Operator's seat for any reason. A child or even a pet could engage an idling machine.

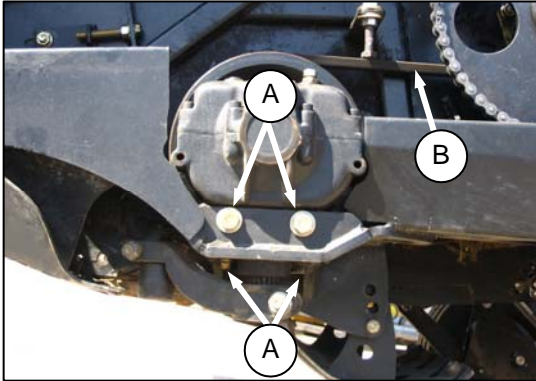

Check torque of four sickle drive box mounting bolts (A) after the first 10 hours operation, and every 100 hours thereafter. Torque bolts to 200 ft-lbf (270 N-m). When tightening, start with the side mounting bolts.

7.8.13.2 Sickle Drive Box Removal

- a. Loosen sickle drive belt (B), and slip off sickle drive box pulley. Refer to one of the following sections, depending on your equipment:
 - Section 7.8.9.1 Tension Adjustment: Sickle Drive Belt - A30-S
 - Section 7.8.10.1 Tension Adjustment: LH Sickle Drive Timing Belt - A30-D
 - Section 7.8.10.4 Tension Adjustment: RH Sickle Drive Timing Belt - A30-D
 - Section 7.8.11.1 Tension Adjustment: LH Sickle Drive Belts - A40-D
 - Section 7.8.11.4 Tension Adjustment: RH Sickle Drive Belt - A40-D
- b. Stroke sickle to its outer limit.
- c. Clean area around sickle head.

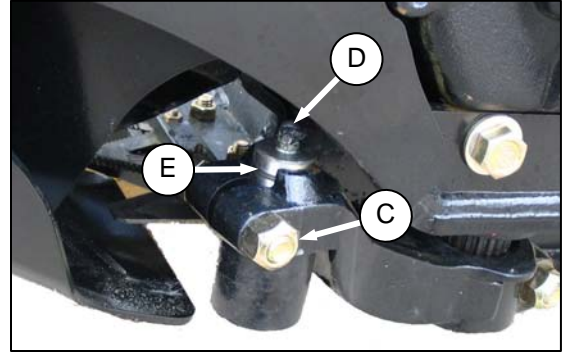

- d. Remove grease zerk (D) from sickle head pin (E).
- e. Remove nut and bolt (C).
- f. Insert screwdriver in groove of pin (E), and pry up on pin to free sickle. Pin does not have to be removed from arm.

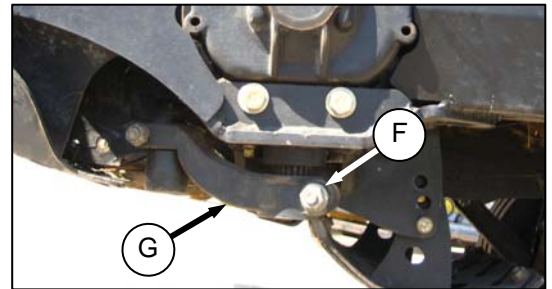

- g. Remove bolt (F) from pitman arm.
- h. Remove pitman arm (G) from sickle drive box output shaft.

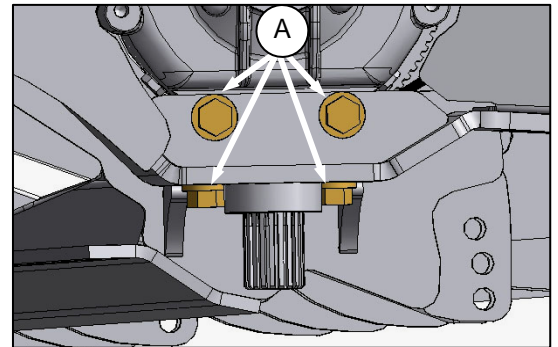

- i. Remove bolts (A) attaching sickle drive box to frame.
- j. Remove sickle drive box.

SECTION 7 MAINTENANCE AND SERVICING

7.8.13.3 Sickle Drive Box Installation

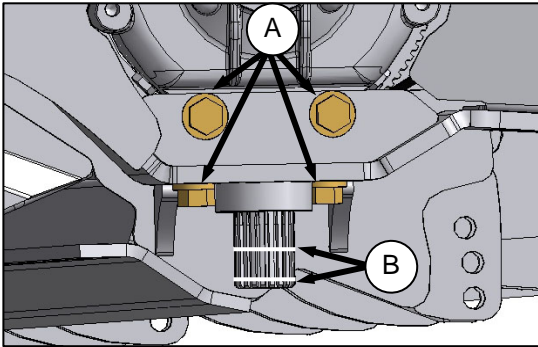

- a. Position sickle drive box as shown, and install four bolts (A). Torque side bolts, and then torque bottom bolts to 200 ft-lbf (270 Nm).

IMPORTANT

Use **only** Grade L9 bolts and flat washers.

- b. Apply Loctite® #243 adhesive (or equivalent) in two bands (B) around shaft as shown, with one band at end of shaft, and one band approximately mid-way.

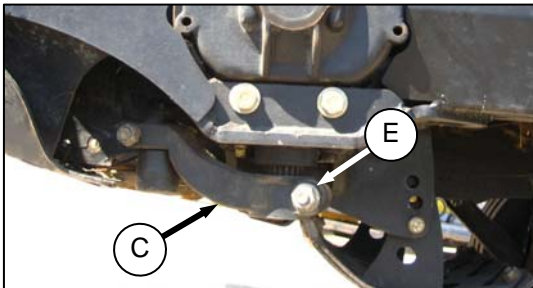

- c. Slide pitman arm (C) onto sickle drive box output shaft.
- d. Rotate sickle drive box pulley to ensure pitman arm just clears frame to ensure proper placement on splines. Remove arm (C), and re-position on splines as required.
- e. Rotate sickle drive box pulley to locate pitman arm at furthest outboard position.

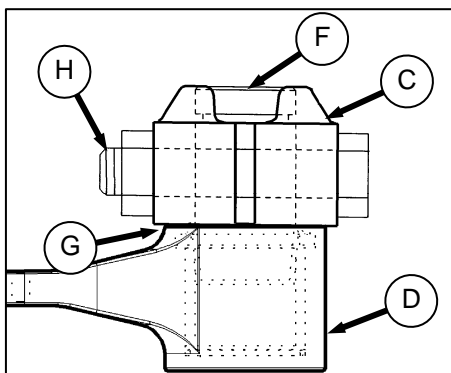

- f. Slide arm (C) up or down on shaft until it just contacts sickle head (D) (0.010 in. [0.25 mm] gap).
- g. Install bolt (E) and nut, and torque to 160 ft-lbf (217 N-m).
- h. Align sickle head (D) with pitman arm (C).
- i. Install sickle head pin (F) in pitman arm (C) and tap it down into the sickle head, ensuring pin is bottomed out in the sickle head.
- j. Tap underside of the sickle head until the pin is flush with the upper face of the pitman arm (C).
- k. Carefully adjust to achieve a 0.010 in. (.25 mm) gap at (G) with the sickle laying flat on the first few guards.

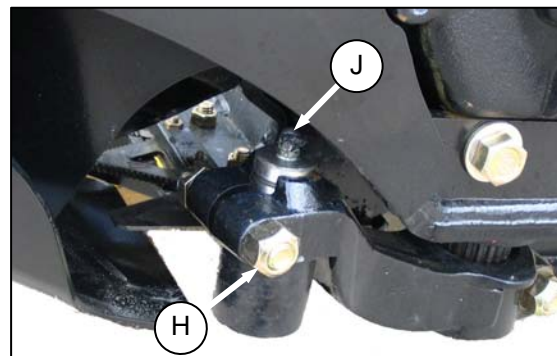

- l. Replace bolt (H) and nut.
- m. Tighten nut to 160 ft-lbf (220 N-m).
- n. Replace grease zerk (J) in pin.
- o. Install drive belt onto sickle drive box pulley and tighten. Refer to one of the following sections, depending on your equipment:
- Section 7.8.9.1 Tension Adjustment: Sickle Drive Belt - A30-S
 - Section 7.8.10.1 Tension Adjustment: LH Sickle Drive Timing Belt - A30-D
 - Section 7.8.10.4 Tension Adjustment: RH Sickle Drive Timing Belt - A30-D
 - Section 7.8.11.1 Tension Adjustment: LH Sickle Drive Belts - A40-D
 - Section 7.8.11.4 Tension Adjustment: RH Sickle Drive Belt - A40-D

SECTION 7 MAINTENANCE AND SERVICING

7.8.13.4 Pulley Removal

- Remove sickle drive box. See previous page.

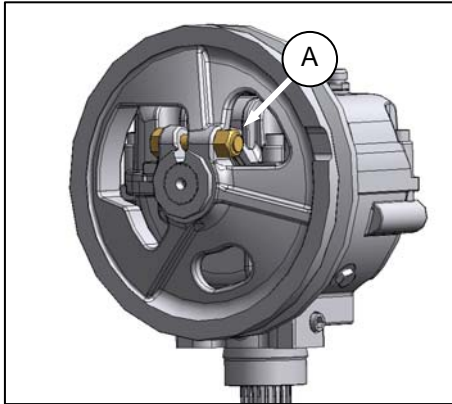

- Loosen nut and bolt (A) from pulley.
- Remove pulley using a 3-jaw puller.

7.8.13.5 Pulley Installation

- Remove any rust or paint from inner spline. For replacement parts, remove oil/grease with degreasing agent.

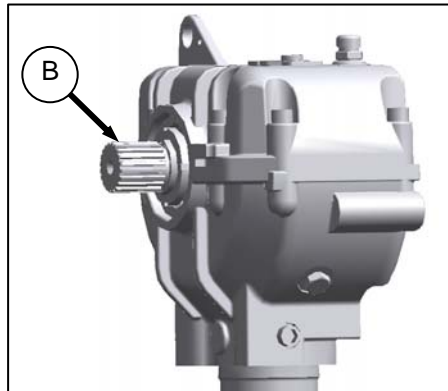

- Apply Loctite® #243 adhesive (or equivalent) in two bands around shaft (B) as shown, with one band at end of spline, and one band approximately mid-way.
- Install pulley on shaft until flush with end of shaft, and secure with bolt (A) and nut. Torque bolts to 160 ft·lbf (217 N·m).
- Install sickle drive box. See previous page.

7.8.13.6 Changing Sickle Drive Box Oil

NOTE

Change sickle drive box lubricant after the first 50 hours operation, and every 1000 hours (or 3 years) thereafter.

- Raise header to allow a suitable container to be placed under sickle drive box drain to collect oil.



CAUTION

Stop engine, and remove key from ignition before leaving Operator's seat for any reason. A child or even a pet could engage an idling machine.

- Engage header lift cylinder stops.



- Remove breather/dipstick and drain plug, and allow oil to drain.
- Replace drain plug and add oil to required level. Use Gear Lubricant, SAE 85W-140, API Service Class GL-5, 2.3 quarts (2.2 liters).
- Disengage lift cylinder stops.

SECTION 7 MAINTENANCE AND SERVICING

7.9 REEL AND REEL DRIVE: A30-S, A30-D



CAUTION

To avoid personal injury, before servicing header/mower conditioner or opening drive covers, follow procedures in Section 7.1 PREPARATION FOR SERVICING.

7.9.1 Reel Drive Chain: A30-S, A30-D

7.9.1.1 Tension

NOTE

For major adjustments, such as after re-positioning reel or auger, adjust belt tension before chain tension.

Adjust reel drive chain (A) tension as follows:

- a. Open shield on header RH side.

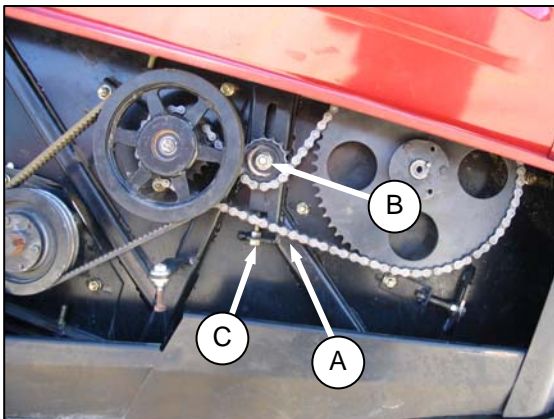

- b. Loosen nut (B) on idler sprocket.
- c. Loosen jam nut on adjuster bolt (C), and back off.
- d. To increase tension, turn adjuster bolt (C) to move idler sprocket downward until total chain slack at (A) is 1/4 in. (6 mm).
- e. Tighten jam nut at (C) and nut (B), and re-check tension.
- f. Close shield before engaging header.

7.9.1.2 Removal

Remove reel drive chain (A) as follows:

- a. Open shield on header RH side.

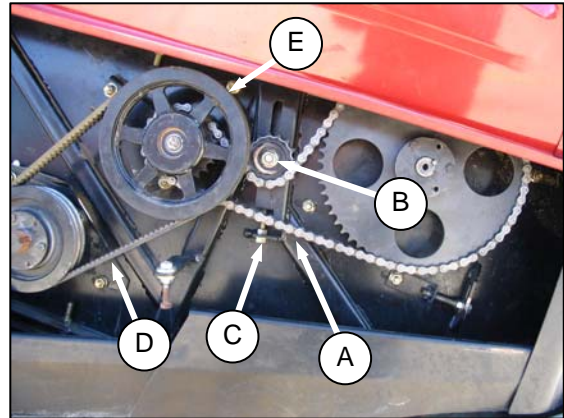

- b. Remove reel drive belt (D) from pulley (E). Refer to Section 7.9.2 Reel Drive Belts: A30-S, A30-D.
- c. Loosen nut (B) on idler sprocket.
- d. Loosen jam nut on adjuster bolt (C) and back off.
- e. Turn adjuster bolt (C) to loosen chain.
- f. Remove chain from sprockets.

7.9.1.3 Installation

Install reel drive chain (A) as follows:

- a. Position chain (A) around sprockets as shown.
- b. Install and tighten reel drive belts (D). Refer to Section 7.9.2 Reel Drive Belts: A30-S, A30-D.
- c. Turn adjuster bolt (C) to move idler sprocket downward until total chain slack at (A) is 1/4 in. (6 mm).
- d. Rotate auger, and check chain for slack at tightest point. Re-adjust position of idler sprocket to achieve required slack.
- e. Tighten jam nut at (C) and nut (B), and re-check tension.
- f. Close shield before engaging header.

SECTION 7 MAINTENANCE AND SERVICING

7.9.2 Reel Drive Belts: A30-S, A30-D

7.9.2.1 Tension Adjustment

IMPORTANT

To prolong drive life, do not over-tighten belts. Belt slippage is used to protect the reel in an overload situation.

Adjust reel drive belts (A) tension as follows:



CAUTION

Stop engine, and remove key from ignition before leaving Operator's seat for any reason. A child or even a pet could engage an idling machine.

- Open shield on header RH side.

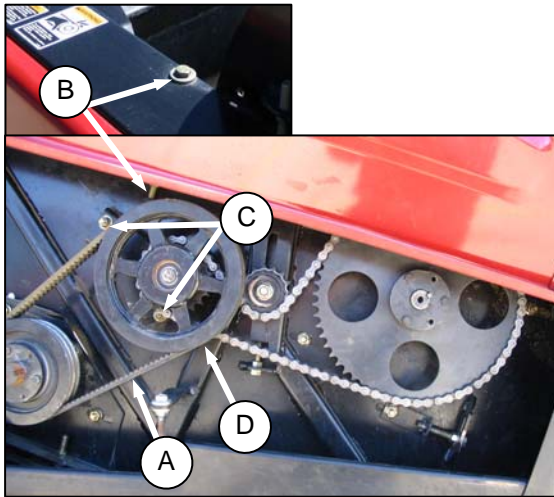

- Loosen jam nut on adjuster bolt (B), and nuts (C).
- Turn adjuster bolt (B) to move pulley (D) so that each belt (A) deflects 3/16 in. (4 mm) when a load of 8–12 lbf (35–40 N) is applied to each belt at mid-span.
- Tighten jam nut on adjuster bolt (B), and nuts (C).

NOTE

Re-adjust tension of new belts after about 5 hours of operation.

- Check reel drive chain tension, and adjust if necessary. See Section 7.9.1 *Reel Drive Chain: A30-S, A30-D*.
- Close shield before engaging header.

7.9.2.2 Removal

Remove reel drive belts (A) as follows:

- Open shield on header RH side.

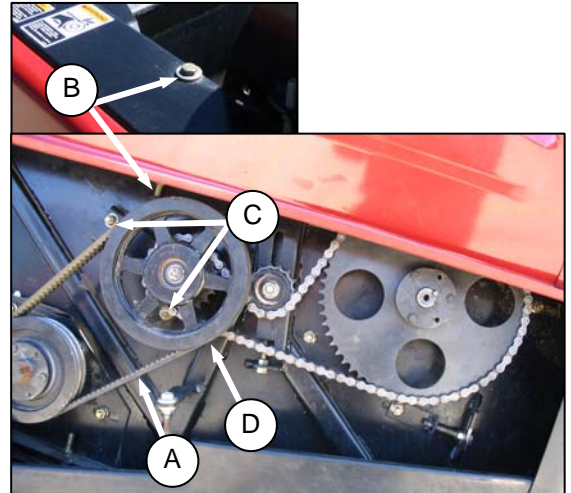

- Loosen jam nut on adjuster bolt (B) and nuts (C) at reel drive arm.
- Turn adjuster bolt (B) to loosen reel drive belts.
- Remove drive belts (A).

7.9.2.3 Installation

IMPORTANT

Reel drive belts are a matched set. Replace both drive belts even if only one needs replacing.

Install reel drive belts (A) as follows:

- Position drive belts (A) on pulleys, ensuring both belts are identical.
- Turn adjuster bolt (B) to move pulley (D) so that each belt (D) deflects 3/16 in. (4 mm) when a load of 8–12 lbf (35–40 N) is applied to each belt at mid-span.
- Tighten jam nut on adjuster bolt (B), and nuts (C).

NOTE

Re-adjust tension of new belts after about 5 hours of operation.

- Check reel drive chain tension, and adjust if necessary. See Section 7.9.1 *Reel Drive Chain: A30-S, A30-D*.
- Close shield before engaging header.

SECTION 7 MAINTENANCE AND SERVICING

7.9.3 Reel Tines and Tine Bar Bearings: A30-S, A30-D

IMPORTANT

Keep reel tines in good condition.
Straighten or replace as required.

7.9.3.1 Removal: Tines and Bearings - Cam End



CAUTION

Stop engine, and remove key from ignition before leaving Operator's seat for any reason. A child or even a pet could engage an idling machine.

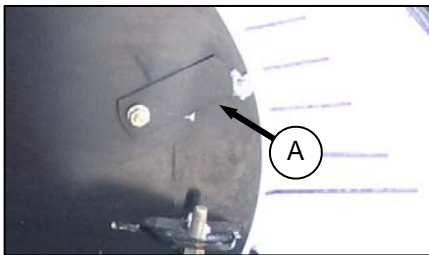

- Loosen bolt on cover (A), and slide cover to expose hole in cam disc. Rotate reel, and align bearing with hole.

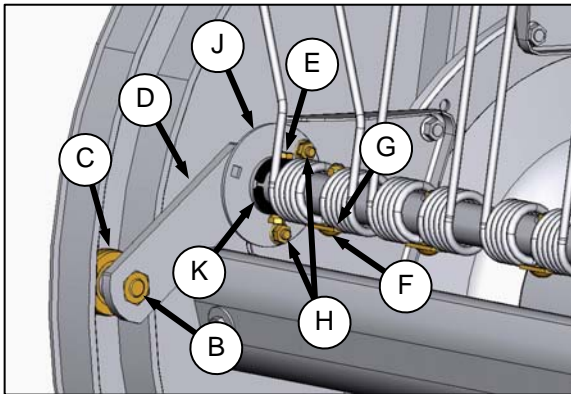

- Remove cam follower bearing bolt (B), bearing (C), and nut.
- Disengage cam arm (D) from the cam track with a pry bar.
- Remove bolt (E), bolt (F), and keeper (G) that connect cam arm (D) and end tines to tine bar.
- Remove bolts (H) securing tine bar bearing support (J) to reel arm.
- Position end of tine bar clear of cam disc, and remove cam arm assembly (D).
- Slide bearing support (J) off tine bar, and remove bearing halves (K).
- Remove nut, bolt, and keeper on each tine to be removed, and slide tine off the bar.

7.9.3.2 Installation: Tines and Bearings - Cam End



CAUTION

Stop engine, and remove key from ignition before leaving Operator's seat for any reason. A child or even a pet could engage an idling machine.

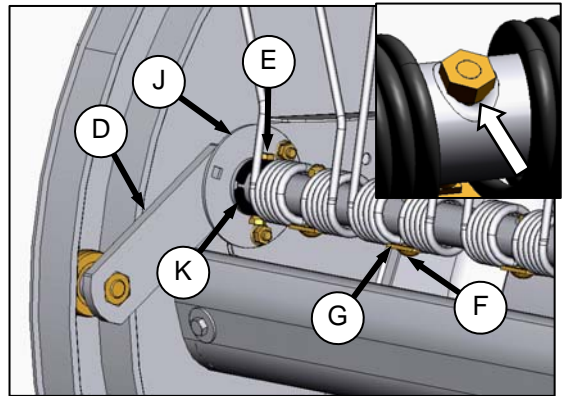

- Install replacement tines on tine bar, and secure with bolt (F) and keeper (G). Install nut with tapered side against tine bar. Do not install bolt in end tine at this time.
- Slide bearing support (J) onto tine bar.
- Position end of tine bar clear of cam disc, and install cam arm assembly (D), on tine bar.
- Engage cam arm into cam track as shown.
- Locate the bearing halves (K) inside the bearing support.

NOTE

Ensure bearings are installed with flanges of bearing facing the centerline of the header/mower conditioner.

- Install bolt (E) through the bearings, tine bar and cam arm shaft. Secure with nut, and torque to 2–3 ft-lbf (2.5–4 N·m).

(continued next page)

SECTION 7 MAINTENANCE AND SERVICING

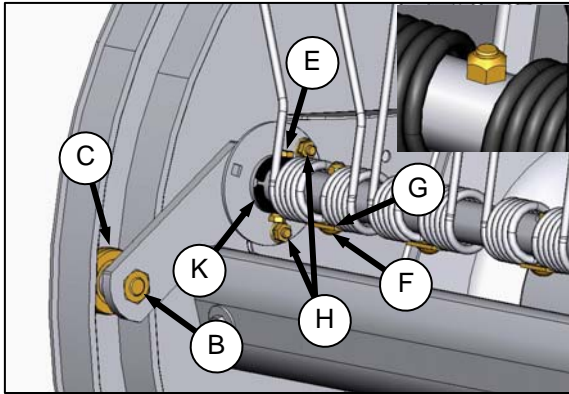

- g. Attach end tine to tine bar with bolt (F) and keeper (G). Install nut with flat side against tine bar.
- h. Attach bearing support to reel arm with bolts and nuts (H). Torque nuts to 21 ft·lbf (29 N·m).
- i. Install cam follower bearing (C) with bolt (B). Apply Loctite® #262 (or equivalent) to bolt threads, and torque to 90 ft·lbf (122 N·m).

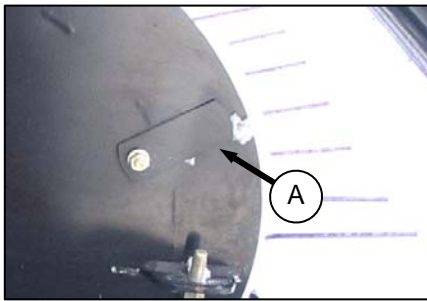

- j. Re-position cover (A) on cam, and tighten bolt.

7.9.3.3 Removal: Tines and Bearings - Opposite Cam End

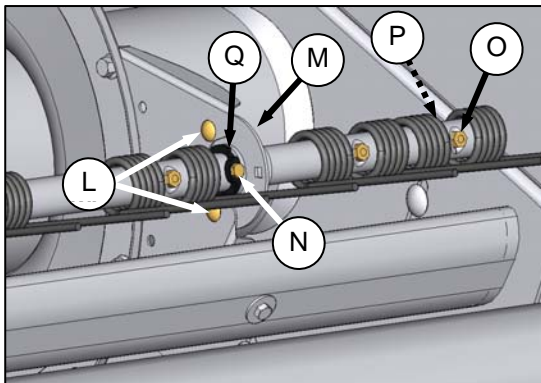

- a. Remove bolts (L) securing tine bar bearing support (M) to reel arm.
- b. Remove bolt (O), and keeper (P) that connect end tines to tine bar.

- c. Remove bolt (N) securing bearing halves to tine bar.
- d. Position end of tine bar clear of cam disc, and slide tines off bar.
- e. Slide bearing support (M) off tine bar, and remove bearing halves (Q).
- f. Remove nut, bolt, and keeper on each tine to be removed, and slide tine off the bar.

7.9.3.4 Installation: Tines and Bearings, Opposite Cam End



CAUTION

Stop engine, and remove key from ignition before leaving Operator's seat for any reason. A child or even a pet could engage an idling machine.

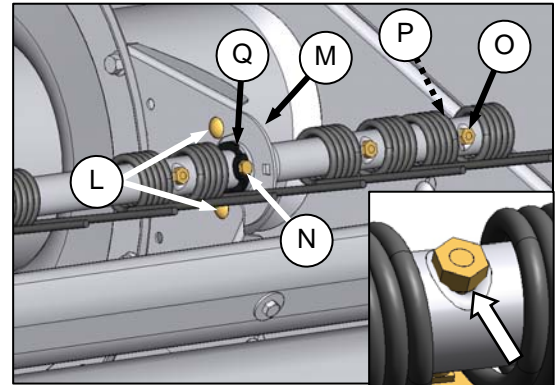

- a. Slide tines and bearing support (M) onto tine bar.
- b. Locate bearing halves (Q) inside the bearing support (M).

NOTE

Ensure bearings are installed with flanges of bearing facing the centerline of the header/mower conditioner.

- c. Install bolt (N) through the bearings, tine bar and cam arm shaft. Secure with nut, and torque to 2–3 ft·lbf (2.5–4 N·m).
- d. Attach bearing support to reel arm with bolts and nuts (L). Torque nuts to 21 ft·lbf (29 N·m).
- e. Secure tines on tine bar with bolt (O) and keeper (P). Install nut with tapered side against tine bar.

SECTION 7 MAINTENANCE AND SERVICING

7.10 REEL AND REEL DRIVE: A40-D



CAUTION

To avoid personal injury, before servicing header/mower conditioner or opening drive covers, follow procedures in Section 7.1 PREPARATION FOR SERVICING.

7.10.1 Reel Drive: A40-D

The reel drive gearbox and hydraulic motor are a factory-assembled unit. The gearbox is sealed, and requires no scheduled maintenance. If service is required for either the gearbox or motor, see your Dealer.

7.10.2 Reel Tines and Tine Bar Bearings: A40-D

IMPORTANT

Keep reel tines in good condition. Straighten or replace as required.

Separate procedures are required to replace reel tines, depending on their location on the reel.

7.10.2.1 Tine and Bearing Replacement: Cam End - Disc #1

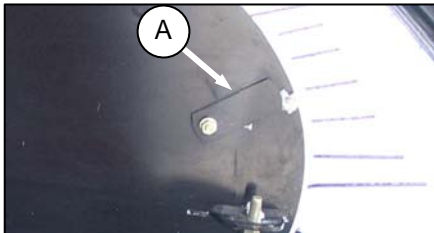
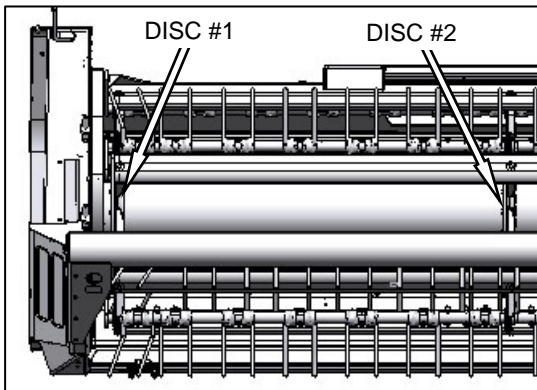

- Loosen bolt on cover (A), and slide cover to expose hole in cam disc. Rotate reel, and align bearing with hole.

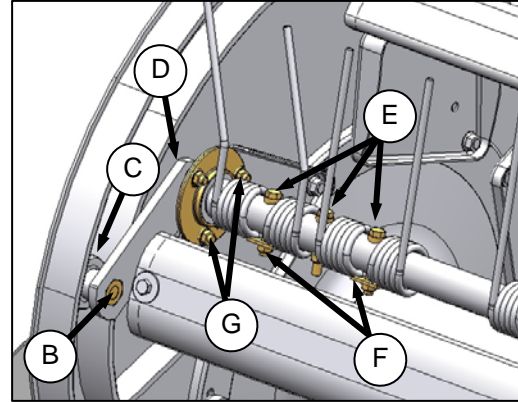

- Remove cam follower bearing bolt (B), bearing (C), and nut.
- Disengage cam arm (D) from the cam track with a pry bar.
- Remove three shoulder bolts (E) and keepers (F) that connect cam arm (D) and end tines to tine bar.
- Remove flangette mounting bolts (G), at discs #1 and #2.
- Position end of tine bar clear of cam disc, and remove cam arm assembly (D), complete with bearing assembly.
- Replace bearing as follows:

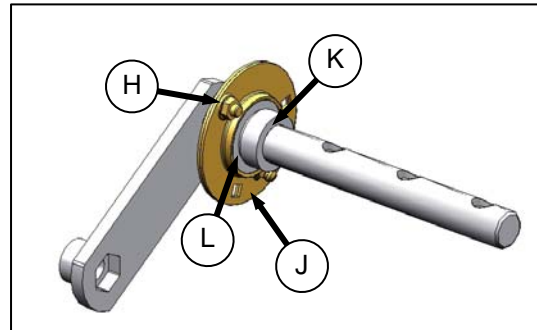

- Remove bolt (H), separate the flangettes (J), and remove inboard flangette.
- Loosen set screw in collar (K), and unlock collar with a punch.
- Slide bearing (L) off shaft, leaving outboard flangette on shaft.
- Slide replacement bearing onto shaft.
- Assemble flangettes (J) with bolt (H), but do not tighten.

(continued next page)

SECTION 7 MAINTENANCE AND SERVICING

h. Replace tine as follows:

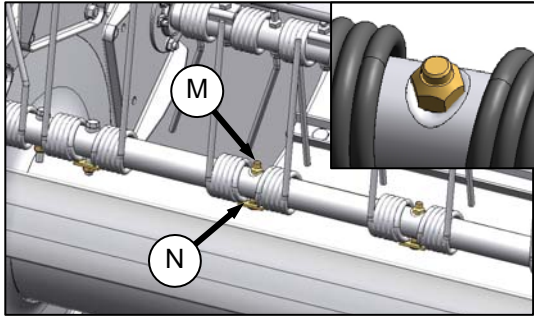

1. Remove bolt (M) and keeper (N) on tine to be replaced.
2. Remove bolts and keepers on tines as required to facilitate replacement of damaged or worn tine.
3. Slide tines off tine bar.
4. Install replacement tine on tine bar, and secure with bolt (M) and keeper (N). Install nut with flat side against tine bar. Do not install bolts in end tines at this time.

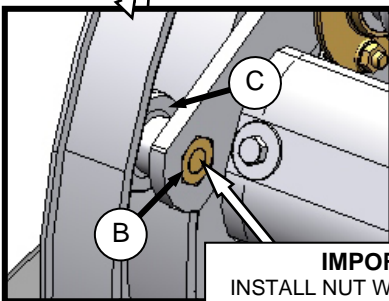
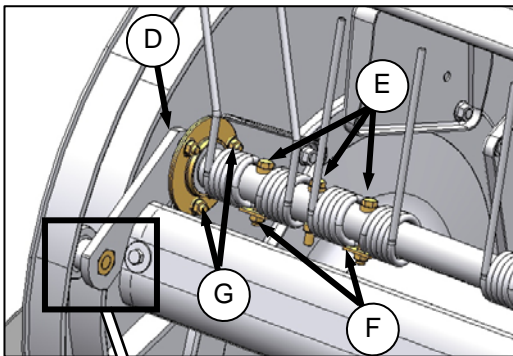

IMPORTANT
INSTALL NUT WITH DISTORTED
THREAD **TOWARDS** BOLT HEAD.

- i. Position end of tine bar clear of cam disc, and install cam arm assembly (D), complete with bearing on tine bar.
- j. Engage cam arm into cam track as shown.
- k. Attach bearing flangettes at discs #1 and #2 with bolts (G). Tighten bolts to 23–26 ft·lbf (31–36 N·m).
- l. Position tines as shown, and install shoulder bolts (E) with keepers (F).
- m. Install cam follower bearing (C) with bolt (B). Apply Loctite® #262 (or equivalent) to bolt threads, and torque to 90 ft·lbf (122 N·m).

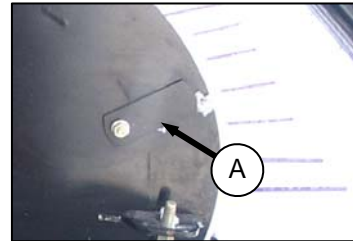

- n. Re-position cover (A) on cam, and tighten bolt.

SECTION 7 MAINTENANCE AND SERVICING

7.10.2.2 Tine and Bearing Replacement: Center Section X

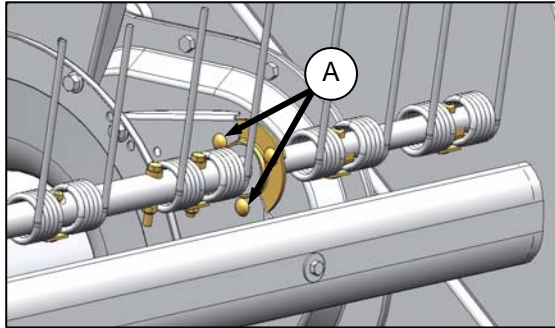
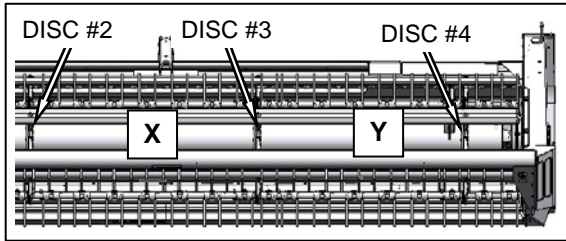

DISC #4

- a. Remove flangette mounting bolts (A) at reel discs #3 and #4.

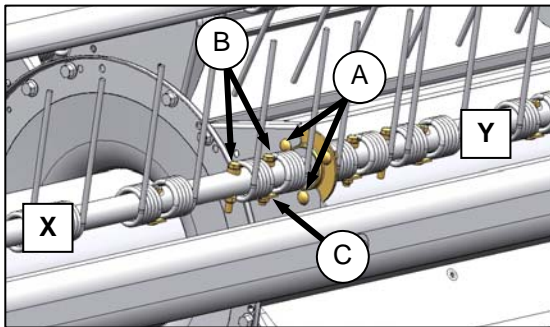

DISC #3

- b. Remove shoulder bolts (B) and keeper (C) connecting tine bar sections 'X' and 'Y' at reel disc #3.
- c. Lift tine bar away from reel arms, and remove complete tine bar section 'Y' (including reel bearings at discs #3 and #4).
- d. To replace tine bar bearing, refer to Section 7.6.4 *Sealed Bearing Installation*.

- e. Replace tine as follows:

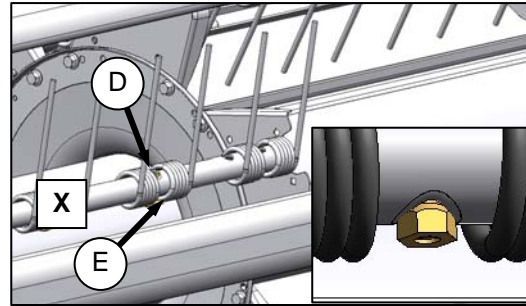

DISC #3

1. Remove bolt (D) and keeper (E) on tine to be replaced.
2. Remove bolts and keepers on tines as required to facilitate replacement of damaged or worn tine.
3. Slide tines off tine bar.
4. Install tines on tine bar, and secure with bolts (D) and keepers (E). Install nut with tapered side against tine bar. Do not install bolts in end tines at this time.

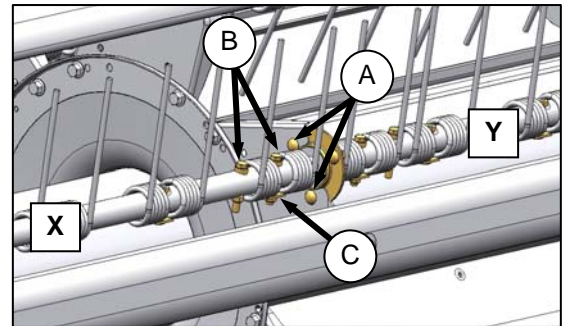

DISC #3

- f. Assemble tine bar section 'Y' (including reel bearings at discs #3 and #4) to tine bar section 'X' at reel disc #3.
- g. Position tines as shown, and install shoulder bolts (B) with keeper (C).

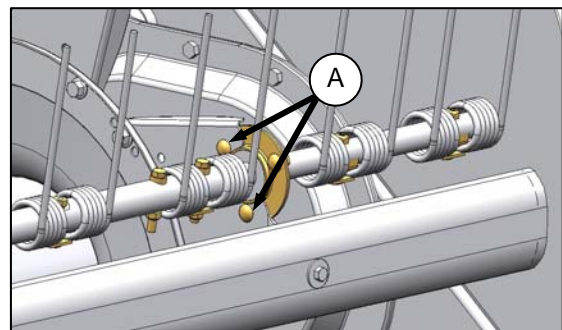

DISC #4

- h. Attach bearing flangettes to reel arm at discs #3 and #4 with bolts (A). Tighten bolts to 23–26 ft·lbf (31–36 N·m).

SECTION 7 MAINTENANCE AND SERVICING

7.10.2.3 Tine and Bearing Replacement: Opposite Cam - Section Y

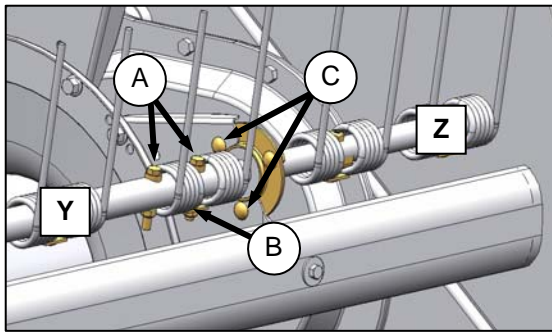
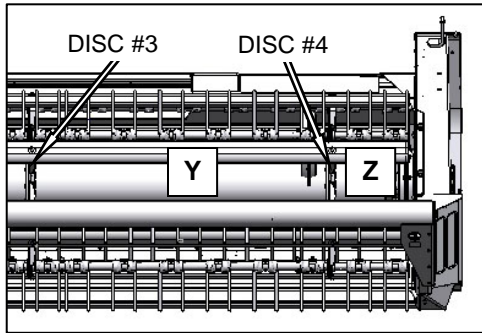

DISC #4

- Remove shoulder bolts (A) and keeper (B) connecting tine bar extension 'Z' to section 'Y' at reel disc #4.
- Remove flangette mounting bolts (C) at reel disc #4.
- Lift tine bar away from reel arm, and remove tine bar extension 'Z' complete with bearing assembly.
- To replace tine bar bearing, refer to Section 7.6.4 *Sealed Bearing Installation*.

- Replace tine as follows:

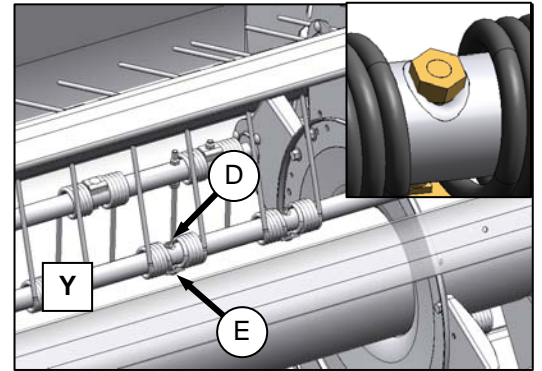

DISC #4

- Remove bolt (D) and keeper (E) on tine to be replaced.
 - Remove bolts and keepers on tines as required to facilitate replacement of damaged or worn tine.
 - Slide tines off tine bar.
 - Install tines on tine bar, and secure with bolts (D) and keepers (E). Install nut with tapered side against tine bar. Do not install bolts in end tine at this time.
- Install tine bar extension 'Z' including bearing to section 'Y' at reel disc #4.

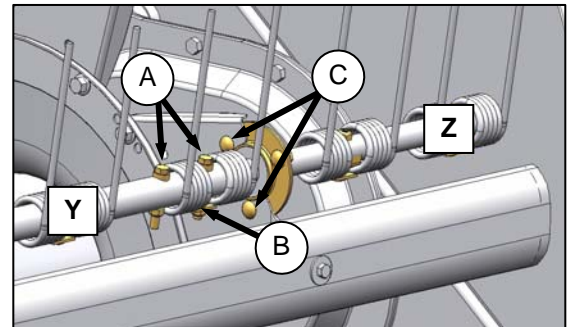

DISC #4

- Install shoulder bolts (A) and keeper (B) with tine to connect tine bar extension.
- Install flangette mounting bolts (C) at reel disc #4. Tighten to 16–20 ft·lbf (21–27 N·m).

SECTION 7 MAINTENANCE AND SERVICING

7.10.2.4 Tine Replacement: Tine Bar Extension - Section Z

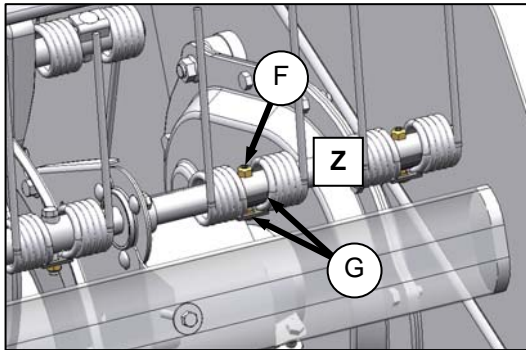
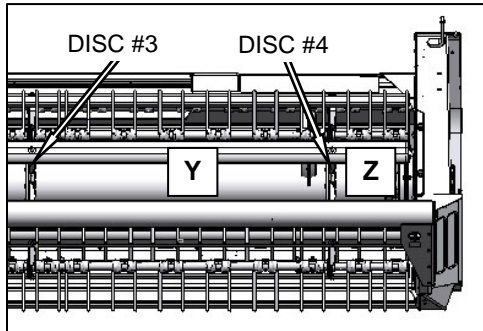

DISC #4

- a. Remove bolt (F) and keepers (G) on tine to be replaced, and slide tines off tine bar.

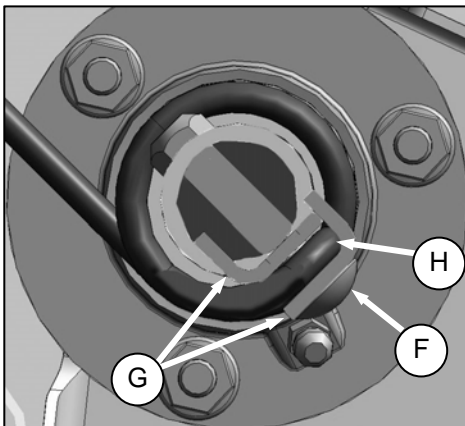

- b. Install tines on tine bar, and secure with bolt (F) and two keepers (G). Tine (H) must be clamped between keepers (G). Install nut with flat side against tine bar extension.

SECTION 7 MAINTENANCE AND SERVICING

7.11 AUGER AND AUGER DRIVE: A30-S, A30-D



CAUTION

To avoid personal injury, before servicing header/mower conditioner or opening drive covers, follow procedures in Section 7.1 PREPARATION FOR SERVICING.

7.11.1 Auger Drive Chain: A30-S

7.11.1.1 Tension

Adjust chain (A) tension as follows:



CAUTION

Stop engine, and remove key from ignition before leaving Operator's seat for any reason. A child or even a pet could engage an idling machine.

- a. Open LH endshield.

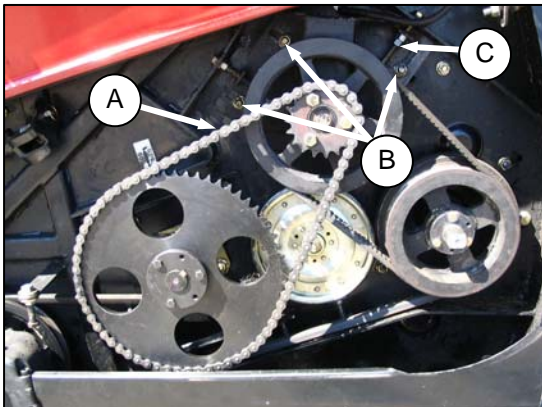

- b. Loosen three bolts (B).
- c. Loosen jam nut on adjuster bolt (C).
- d. Turn adjuster bolt (C) to adjust chain (A) tension. Deflection at (A) should be 1/4 in. (6 mm).
- e. Tighten bolts (B).
- f. Tighten jam nut on adjuster bolt (C).
- g. Close endshield.

7.11.1.2 Removal

Remove chain (A) as follows:

- a. Open LH endshield.

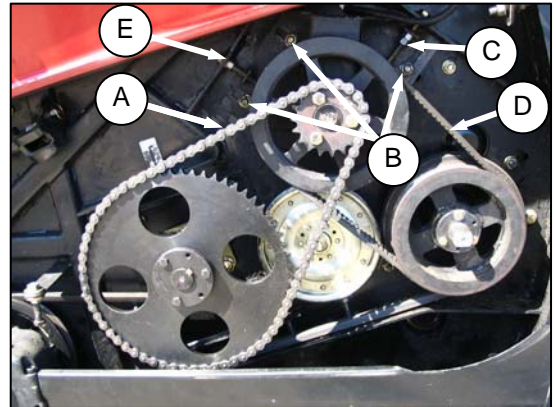

- b. Loosen three bolts (B).
- c. Loosen jam nut on adjuster bolt (C).
- d. Turn adjuster bolt (C) to loosen chain (A).
- e. Remove chain.

7.11.1.3 Installation

Install chain (A) as follows:

- a. Position chain (A) on sprockets as shown.
- b. Turn adjuster bolt (C) to adjust chain tension. Deflection at (A) should be 1/4 in. (6 mm).
- c. Tighten jam nut on adjuster bolt (C).

NOTE

Minor belt tension adjustments may be made without affecting chain tension. For major adjustments, like after re-positioning reel or auger, adjust chain tension before belt tension.

- d. Check auger drive V-belt (D) tension. Each belt should deflect 3/16 in. (4 mm) at mid-span when a load of 8–12 lbf (35–40 N) is applied to each belt. If necessary, adjust as follows:
 1. Loosen jam nut on adjuster bolt (E).
 2. Turn adjuster bolt (E) to achieve tension as per above.
 3. Tighten bolts (B).
 4. Tighten jam nut at (E).
- e. Close shield before engaging header.

SECTION 7 MAINTENANCE AND SERVICING

7.11.2 Auger Drive Chain: A30-D

7.11.2.1 Tension



CAUTION

Stop engine, and remove key from ignition before leaving Operator's seat for any reason. A child or even a pet could engage an idling machine.

- a. Open LH endshield.

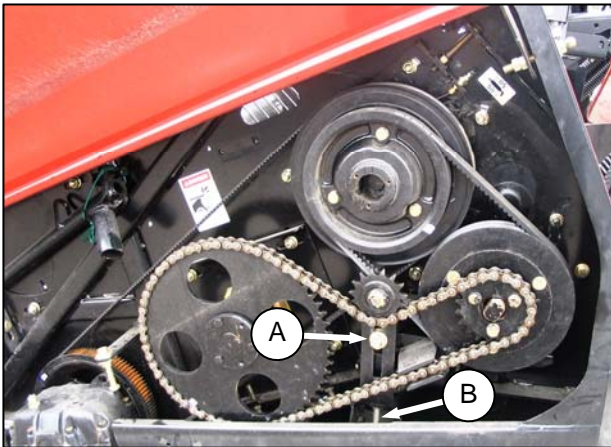

- b. Loosen nut (A) on idler sprocket support.
- c. Turn adjuster bolt (B) to give 0.2 in. (5 mm) slack at mid-span of chain. Tighten nut (A) on idler sprocket support.
- d. Rotate auger, and check chain for slack at tightest point. Re-adjust position of idler sprocket to achieve required slack.
- e. Close endshield.

7.11.2.2 Removal

- a. Open LH endshield.
- b. Loosen nut (A) on idler sprocket support.
- c. Turn adjuster bolt (B) to loosen chain so that it can be removed from small sprocket.
- d. Remove chain from large sprocket.

7.11.2.3 Installation

- a. Position chain around sprockets as shown.
- b. Turn adjuster bolt (B) to give 0.2 in. (5 mm) slack at mid-span of chain. Tighten nut (A) on idler sprocket support.
- c. Rotate auger and check chain for slack at tightest point. Re-adjust position of idler sprocket to achieve required slack.
- d. Close endshield before engaging header.

SECTION 7 MAINTENANCE AND SERVICING

7.11.3 Auger Drive Belt: A30-S

7.11.3.1 Tension

IMPORTANT

To prolong drive life, do not over-tighten belts. Belt slippage is used to protect the auger in an overload situation.

NOTE

Minor belt tension adjustments may be made without affecting chain tension. For major adjustments, like after re-positioning reel or auger, adjust chain tension before belt tension.

Adjust auger drive belts (A) tension as follows:



CAUTION

Stop engine, and remove key from ignition before leaving Operator's seat for any reason. A child or even a pet could engage an idling machine.

- Open LH endshield.

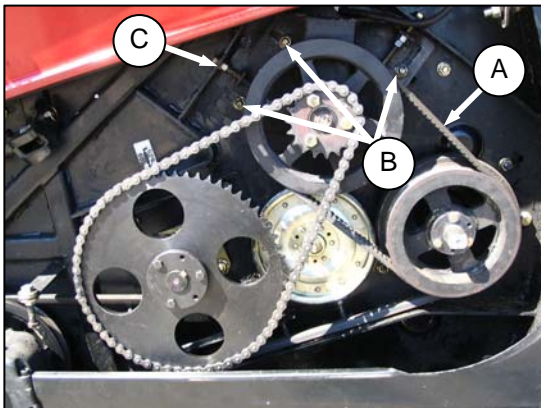

- Loosen three bolts (B).
- Loosen jam nut on adjuster bolt (C).
- Turn adjuster bolt (C) so that each belt deflects 3/16 in. (4 mm) at mid-span when a load of 8–12 lbf (35–40 N) is applied to each belt.
- Tighten bolts (B).
- Tighten jam nut at (C).
- Close shield before engaging header.

7.11.3.2 Removal

- Open LH endshield.
- Remove chain (D) from small sprocket as follows:

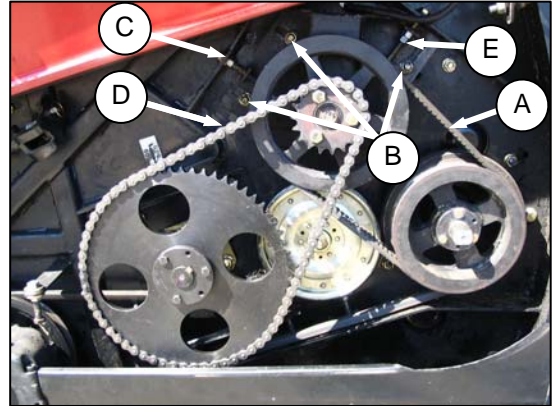

- Loosen three bolts (B).
 - Loosen jam nut on adjuster bolt (E), and turn adjuster bolt (E) to loosen chain (D).
 - Remove chain from small sprocket.
- Loosen jam nut on adjuster bolt (C).
 - Turn adjuster bolt (C) to loosen auger drive belts (A).
 - Remove belts (A).

7.11.3.3 Installation

IMPORTANT

Auger drive belts are a matched set. Replace both drive belts even if only one needs replacing.

- Position auger drive belts (A) as shown.
- Install auger drive chain (D) as follows:
 - Locate chain (D) onto small sprocket.
 - Turn adjuster bolt (E) to tighten chain. Deflection at (D) should be 1/4 in. (6 mm).
 - Tighten jam nut on adjuster bolt (E)
- Turn adjuster bolt (C) so that each belt deflects 3/16 in. (4 mm) at mid-span when a load of 8–12 lbf (35–40 N) is applied to each belt.
- Tighten jam nut on adjuster bolt (C), and the three bolts (B).

NOTE

Re-adjust tension of a new belt after about 5 hours of operation.

- Close endshield.

SECTION 7 MAINTENANCE AND SERVICING

7.11.4 Auger Drive Belts: A30-D

7.11.4.1 Tension

IMPORTANT

To prolong drive life, do not over-tighten belt. Belt slippage is used to protect the auger in an overload situation.

NOTE

Minor belt tension adjustments may be made without affecting chain tension. For major adjustments, like after re-positioning reel or auger, adjust chain tension before belt tension.

Adjust auger drive belts (A) tension as follows:



CAUTION

Stop engine, and remove key from ignition before leaving Operator's seat for any reason. A child or even a pet could engage an idling machine.

- a. Open LH endshield.

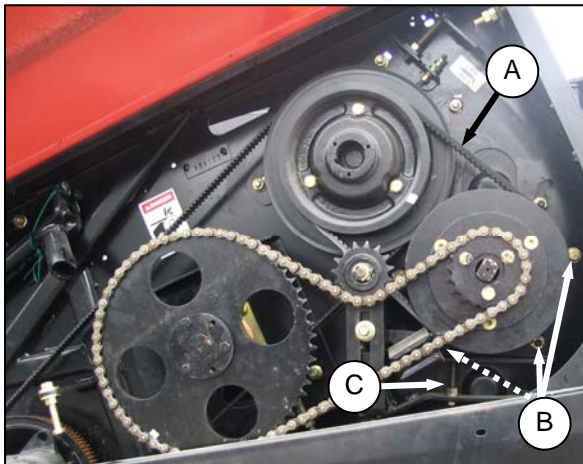

- b. Loosen three bolts (B).
- c. Loosen jam nut on adjuster bolt (C).
- d. Turn adjuster bolt (C) so that each belt deflects 3/16 in. (4 mm) at mid-span when a load of 8–12 lbf (35–40 N) is applied to each belt.
- e. Tighten bolts (B), and jam nut at (C).

NOTE

Re-adjust tension of new belts after about 5 hours of operation.

- f. Close shield before engaging header.

7.11.4.2 Removal

- a. Open LH endshield.
- b. Remove auger drive chain (D) as follows:

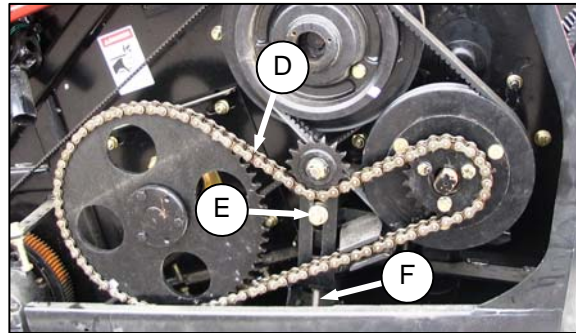

1. Loosen nut (E) on idler sprocket support.
2. Turn adjuster bolt (F) to loosen chain (D).
3. Remove chain from small sprocket.
- c. Loosen three bolts (B). See illustration opposite.
- d. Loosen jam nut on adjuster bolt (C).
- e. Turn adjuster bolt (C) to loosen auger drive belts (A).
- f. Remove belts (A).

7.11.4.3 Installation

IMPORTANT

Auger drive belts are a matched set. Replace both drive belts even if only one needs replacing.

- a. Position auger drive belts (A) as shown in previous column.
- b. Turn adjuster bolt (C) so that belts (A) deflect 3/16 in. (4 mm) at mid-span when a load of 8–12 lbf (35–40 N) is applied to each belt.
- c. Tighten bolts (B), and jam nut at (C).
- d. Install auger drive chain (D) as follows:
 1. Position chain on small sprocket.
 2. Turn adjuster bolt (F) to give 0.2 in. (5 mm) slack at mid-span of chain. Tighten nut (E) on idler sprocket support.
 3. Rotate auger, and check chain for slack at tightest point. Re-adjust position of idler sprocket to achieve required slack.
- e. Close endshield.

SECTION 7 MAINTENANCE AND SERVICING

7.11.5 Auger Pans

The high density polyethylene auger pans are repairable and replaceable. Refer to the Technical Service Manual, MD Part #169048 for details on replacing the pans.

IMPORTANT

To prolong the life of the auger pan, be sure to check that reel tines do not contact the pans when adjusting the reel position or tine pitch.

Stones and other debris can deform the polyethylene pans. If this occurs, the pans can be straightened as follows:



CAUTION

To avoid personal injury, before servicing header/mower conditioner or opening drive covers, follow procedures in Section 7.1 PREPARATION FOR SERVICING, and Section 7.2 RECOMMENDED SAFETY PROCEDURES.

- Heat the deformed area with a heat gun until the poly is almost sticky.
- Push out the dent, and then apply a cold wet rag. Keep wetting the rag in cold water, and applying it on the area until cool. This ensures the poly retains its shape.

NOTE

If the dent is too severe, and has stretched the poly, it may be necessary to locally remove the poly. Use a plastic welder to rejoin the material. Replacement pans are also available from your Dealer.

7.11.6 Rubber Fingers

Rubber fingers should be replaced if missing or damaged.

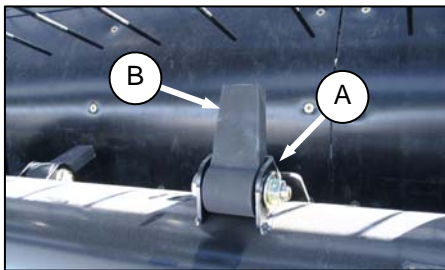

- Remove nut and bolt (A), and remove finger (B).
- Position new finger in holder, and install bolt and nut. Rubber finger should be free to move after bolt is tightened.

7.11.7 Stripper Bars

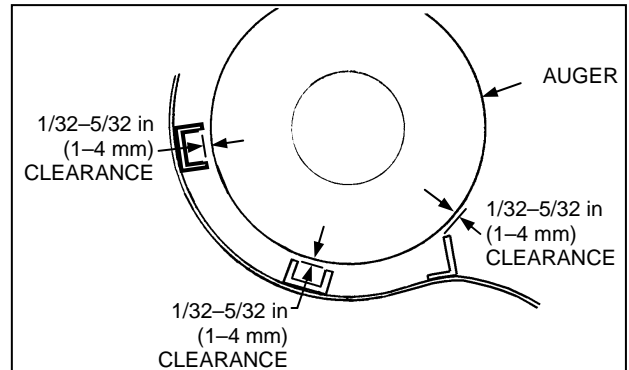

To maintain proper clearance between auger and stripper bars, bars may need replacing due to wear or damage. Shims may also need to be installed to compensate for local irregularities in the structure.

If after adjusting stripper bars, auger position needs to be adjusted, refer to Section 6.17.4 *Auger Position*.



WARNING

To avoid bodily injury or death from unexpected start-up or fall of raised machine, stop engine, remove key, and engage lift cylinder stops before going under machine.

7.11.7.1 Stripper Bar Removal

Heavy crops may cause plugging across the auger due to restricted flow at the stripper bars. Remove the lower stripper bar, and if necessary, remove the center stripper bar as follows:

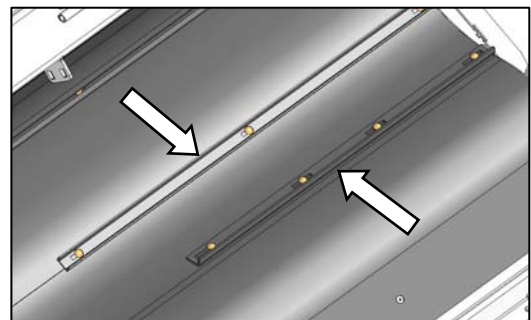

AUGER NOT SHOWN FOR CLARITY

- Remove bolts attaching stripper bar to pan.
- Remove stripper bar.
- Replace bolts in pan.

NOTE

Special countersunk bolts are available from your Dealer.

SECTION 7 MAINTENANCE AND SERVICING

7.11.7.2 Stripper Bar Replacement



WARNING

To avoid bodily injury or death from unexpected start-up or fall of raised machine, stop engine, remove key, and engage lift cylinder stops before going under machine.

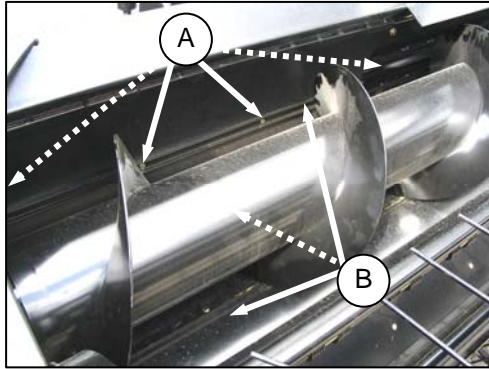

- Remove four nuts and bolts (A) that secure each stripper bar (B) (LH and RH) to the pan, and remove bars. There are six bars in total.
- Position new bars (B) on pan as shown, with upper flange on front bar facing forward.
- Install three bolts and nuts (A) in each bar, and torque to 150 ft-lbf (203 N-m).
- Check clearance between auger and stripper bars.
- Loosen bolts (A), and add shims between stripper bars and pan at bolt locations as required to obtain clearance as shown.
- Re-tighten bolts to specified torque.

7.11.7.3 Front Stripper Bar Extensions

Extensions for the front stripper bar are provided for installation (if required for certain crop conditions), or especially in tall crops that cause material to bunch up at the ends of the conditioner rolls.

Stripper bar extensions will allow the auger to carry the crop more towards the center, rather than prematurely feeding it to the conditioner.

- Raise header, and engage lift cylinder stops.

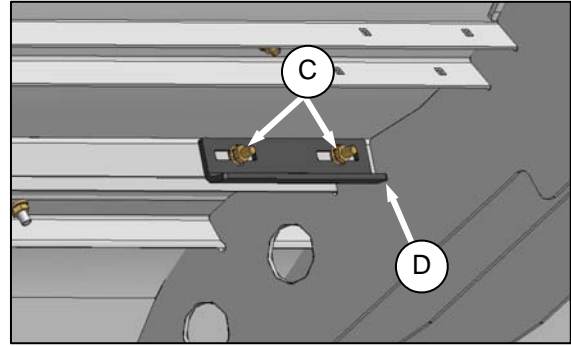

- Remove nuts and carriage bolts (C) securing the two extensions (D) to underside of header pan support, and retain for re-installation.

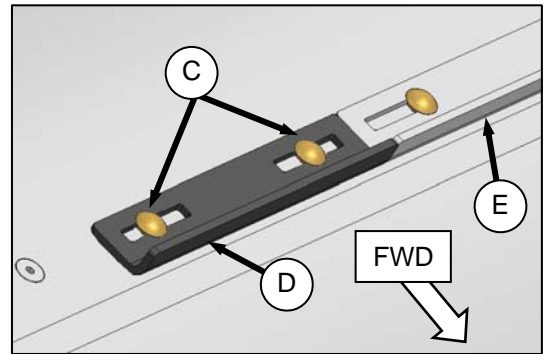

LH SIDE
(AUGER NOT SHOWN FOR CLARITY)

- Position extension (D) at inboard end of front stripper bars (E), and mark locations of the two holes onto the plastic pan.
- Drill two 5/16 in. (8 mm) holes at these locations.
- Install extension with carriage bolts (C) removed at sub-step b.
- Repeat above steps for other extension.

7.12 AUGER AND AUGER DRIVE: A40-D

The A40-D header auger is driven directly from a hydraulic motor, and there are no belts or chains to maintain.

For auger and stripper bar maintenance procedures, refer to Section 7.11.5 *Auger Pans*, Section 7.11.6 *Rubber Fingers*, and Section 7.11.7 *Stripper Bars*.

SECTION 7 MAINTENANCE AND SERVICING

7.13 CONDITIONER



CAUTION

To avoid personal injury, before servicing header/mower conditioner or opening drive covers, follow procedures in Section 7.1 PREPARATION FOR SERVICING.

7.13.1 Changing Gearbox Oil

NOTE

Change conditioner drive gearbox lubricant after the first 50 hours of operation, and every 1000 hours (or 3 years) thereafter.

- Lower header to ground.
- Open driveline shield.
- Place a suitable container under gearbox drain to collect oil.

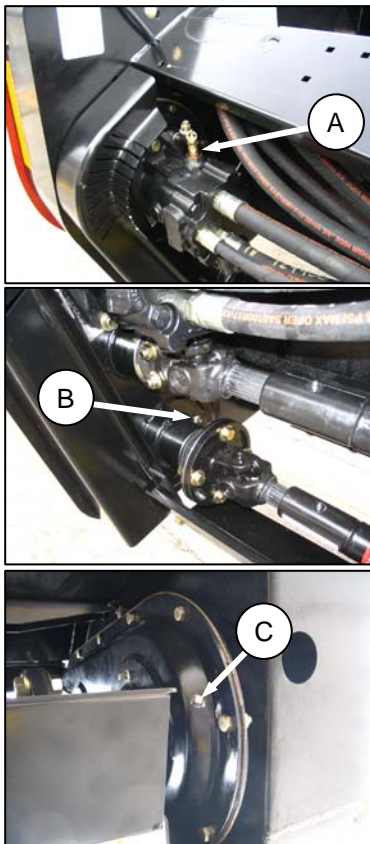

- Remove breather (A), check plug (B), and drain plug (C).
- Allow oil to drain.

- Replace drain plug (C), and add oil at (A) to required level. Use Gear Lubricant, SAE 85W-140, API Service Class GL-5, 1.06 quarts (1.0 liters).
- Oil is at required level when it runs out of check plug (B).

7.13.2 Forming Shield Removal

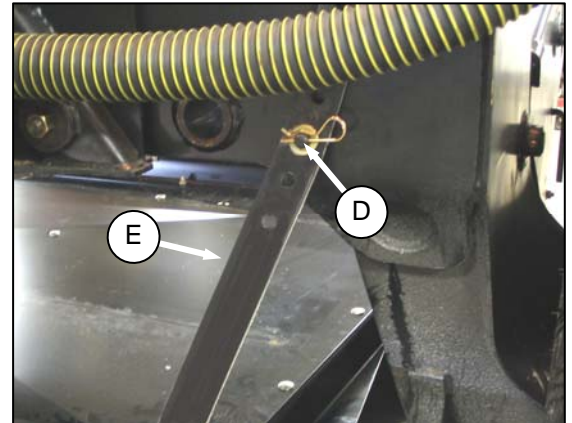

- Remove hairpins (D), and washers that secure straps (E) to frame.
- Hold onto forming shield, and slip straps off pins. Lower forming shield to ground.

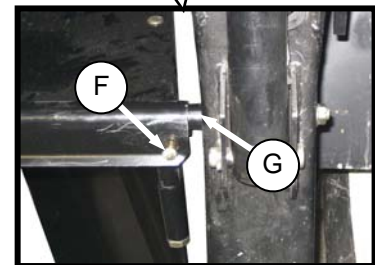

- Remove two clevis pins (F) from forming shield forward end.
- Lift forming shield off bolts (G) in windrower legs, and lower to ground. Replace clevis pins in forming shield.
- Slide forming shield out from under windrower, or drive windrower away from forming shield.

SECTION 7 MAINTENANCE AND SERVICING

7.13.3 Disassemble Forming Shield

- a. Invert forming shield onto top.

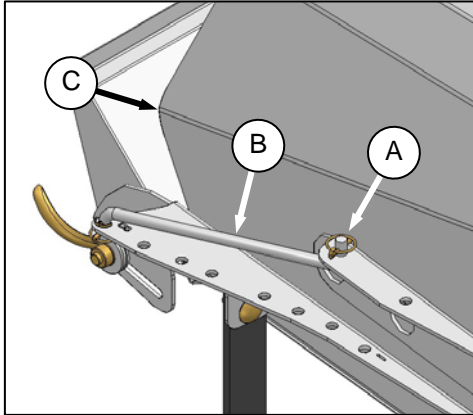

- b. Remove lynch pin (A) from adjuster rods (B), and disassemble rods from side deflectors (C).

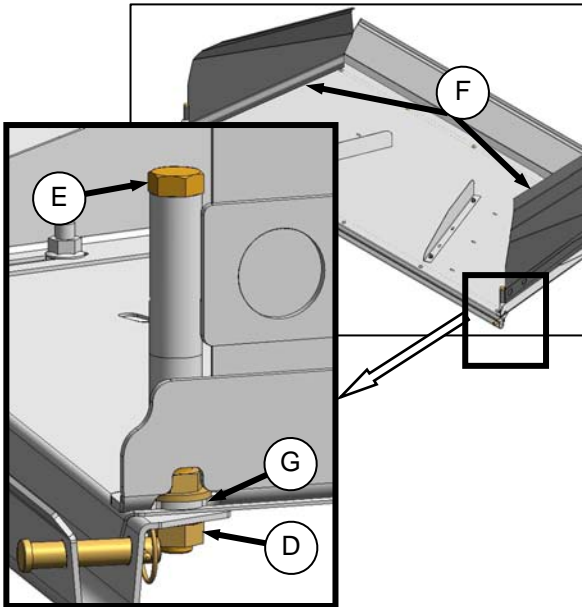

- c. Disassemble nut (D) from bolt (E), and lift deflector (F) and washer (G) off forming shield. Repeat for other deflector.

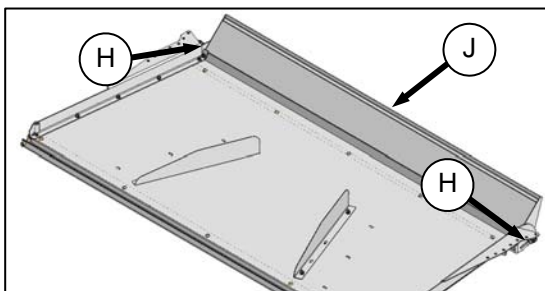

- d. Disassemble locking handles (H), and remove bolts.

- e. Disassemble fluffer shield (J) from forming shield cover.

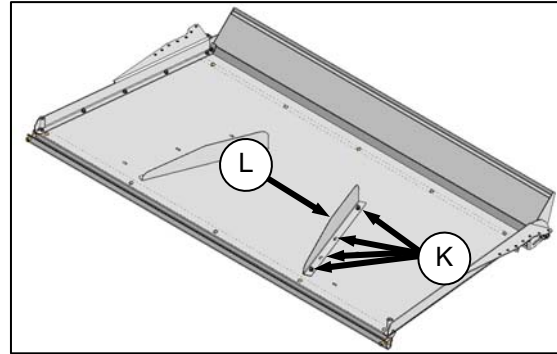

- f. Remove bolts (K) to remove deflector fins (L) from cover.

7.13.4 Assemble Forming Shield

Reverse the procedure in Section 7.13.3 Disassemble Forming Shield.

7.13.5 Install Forming Shield

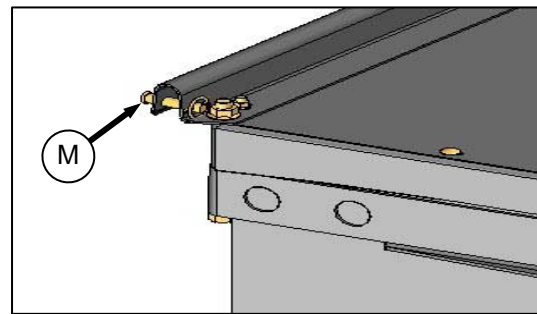

- a. Remove two clevis pins (M) from forming shield forward end.



- b. Position forming shield under the windrower frame.

(continued next page)

SECTION 7 MAINTENANCE AND SERVICING

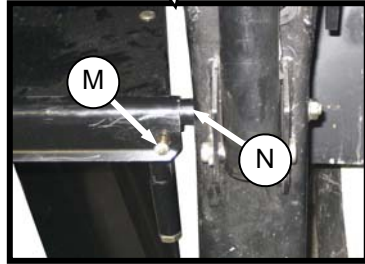

- c. Lift forming shield onto bolts (N) in windrower legs, and secure with clevis pins (M) and hairpin.

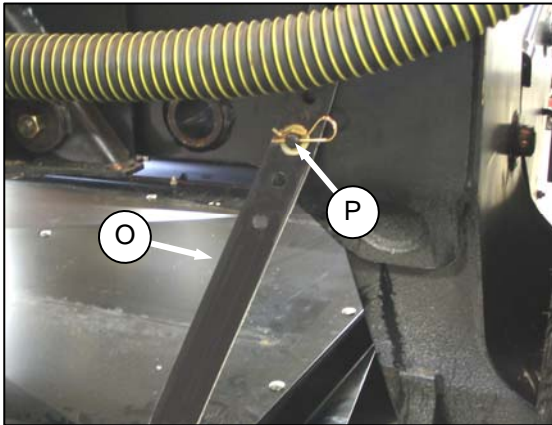

- d. Lift aft end of forming shield, and attach straps (O) to pins (P) on windrower frame. Install washer and hairpin to secure strap. Use the middle hole, and adjust height to suit the crop.

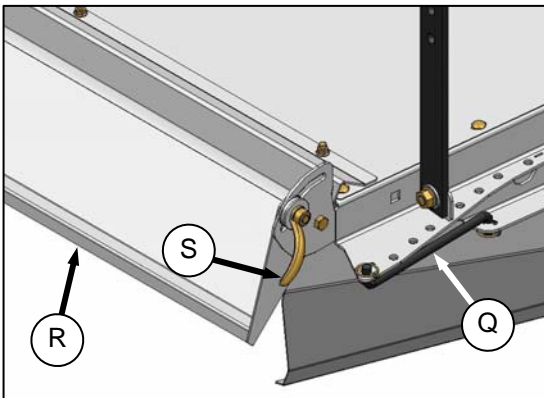

BOTH SIDES

- e. Set forming shield side deflectors to desired width by re-positioning adjuster bars (Q). Use the same hole location on both sides.
f. Adjust fluffer shield (R) to middle position. Loosen handles (S) if required.

7.13.6 Hydraulic Drive Motor Removal: All Models

- Open shield covering conditioner drive.
- On pull-type machines**, disconnect hydraulic hoses from the motor, and install caps on hose ends and motor ports.
- On self-propelled machines**, disconnect hoses at couplers on motor.

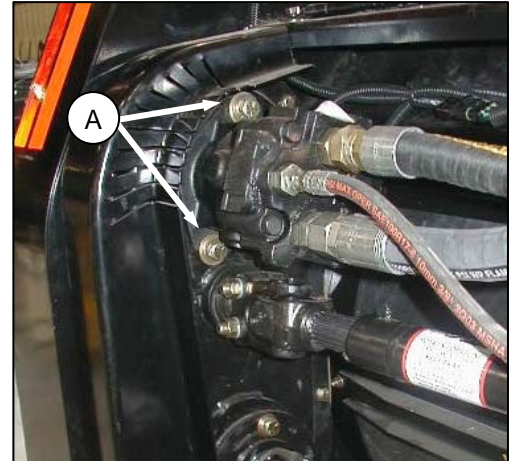

- Remove two bolts (A) securing motor to gearbox, and remove motor.

7.13.7 Hydraulic Drive Motor Installation: All Models

Install hydraulic drive motor onto the gearbox (A) as follows:

- Clean off excess sealant from motor flange and gearbox face.
- Apply light coat of silicone to motor flange, and position motor on gearbox as shown until mounting holes are aligned, and pinion engages gear in gearbox.
- Install bolts (A), and washers, and torque to 75 ft-lbf (102 N·m).
- Re-connect hoses to motor.

SECTION 7 MAINTENANCE AND SERVICING

7.13.8 Gearbox Removal: A30-S

- a. Remove hydraulic drive motor. Refer to Section 7.13.6 *Hydraulic Drive Motor Removal: All Models*.

NOTE

It is not necessary to disconnect the motor hoses for this operation.

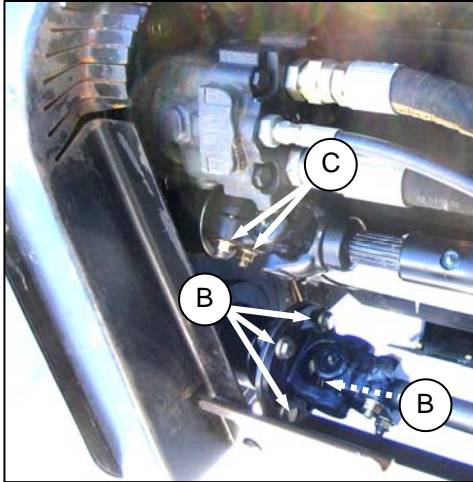

- b. Remove four nuts and bolts (B) from the lower roll driveshaft, and swing driveline clear of gearbox.
- c. Remove two nuts and bolts (C) from the upper roll shaft at the gearbox, and pull driveline clear of gearbox.
- d. Open endshield on LH side of header.
- e. Remove the auger drive belts (E) from the drive pulley as follows:

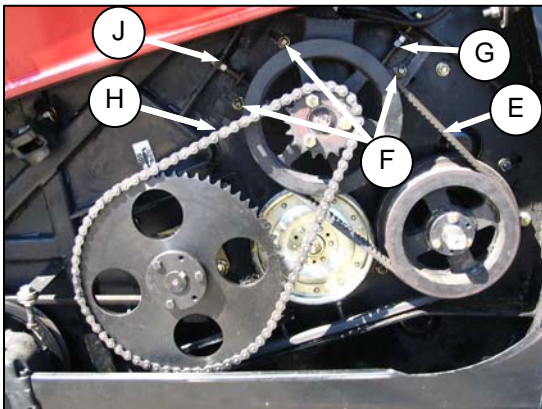

1. Loosen three bolts (F).
2. Loosen jam nut on adjuster bolt (G).
3. Turn adjuster bolt (G) to loosen chain (H).
4. Loosen jam nut on adjuster bolt (J).
5. Turn adjuster bolt (J) to loosen auger drive belts (E).
6. Remove belts (E) from drive pulley.

- f. Remove the auger drive pulley (F) as follows:

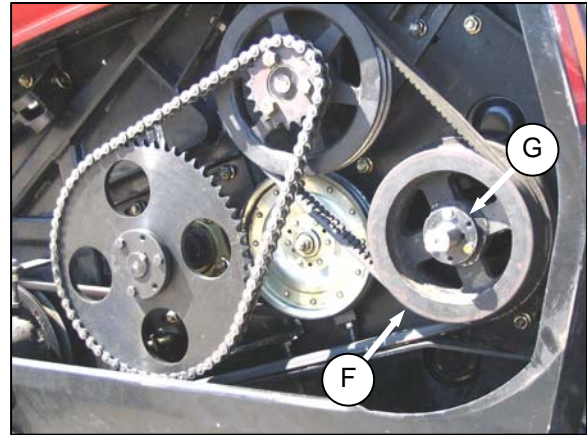

1. Remove three bolts from tapered bushing (G) in pulley (F).
2. Install bolts in the two threaded holes in bushing, and tighten to release the bushing.
3. Remove pulley, bushing, and key.

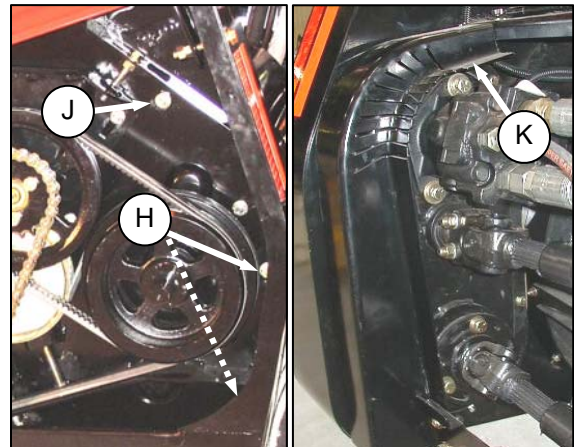

- g. Remove two bolts (H), and nut and bolt (J) attaching channel (K) to endsheet, and remove channel (K).

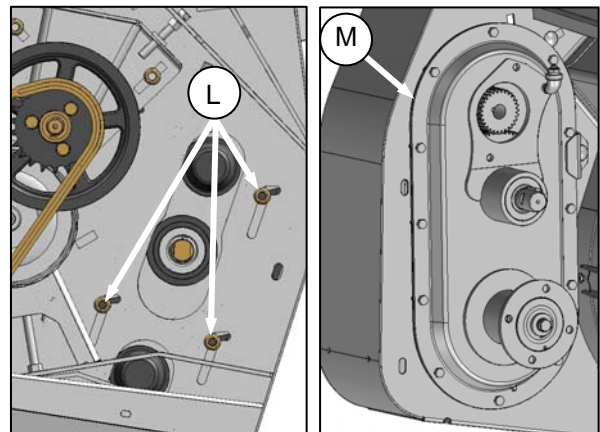

- h. Remove three flanged lock nuts (L) that secure gearbox (M) to header endsheet, and remove gearbox.

SECTION 7 MAINTENANCE AND SERVICING

7.13.9 Gearbox Installation: A30-S

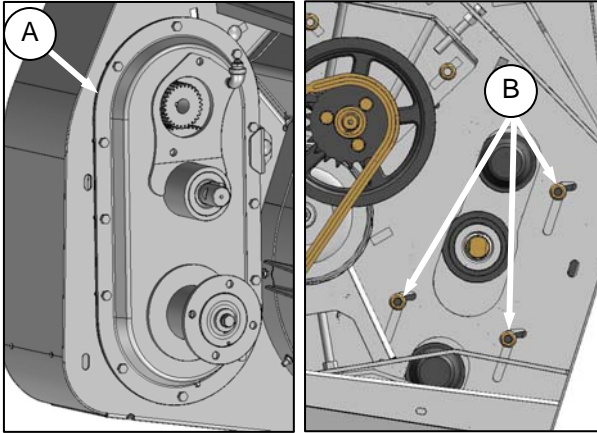

- Position gearbox (A) as shown, picking up the three holes (B) in the endsheet. See above.
- Install three flanged locknuts at (B). Do not tighten.

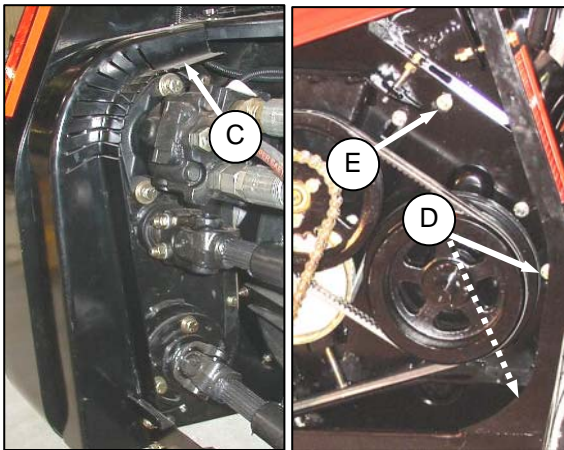

- Position channel (C) as shown, picking up the three holes in the endsheet.
- Install bolts (D) in the lower two holes and bolt and nut (E) in the upper hole, and tighten. Install bolt (E) with head on backside.

- Install auger drive pulley (F) as follows:

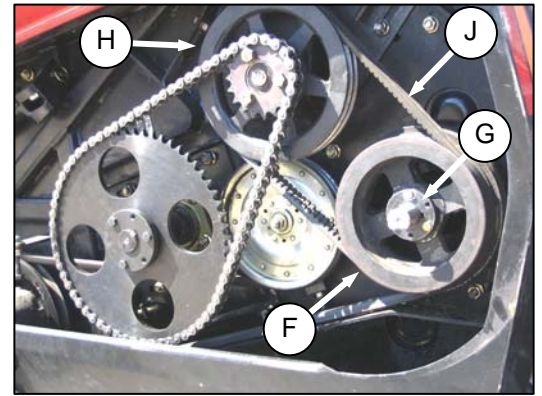

- Slide pulley (F) onto shaft with key.
- Install tapered bushing (G) onto shaft, ensuring holes are aligned with holes in pulley.
- Align pulley (F) and countershaft pulley (H) faces to within .06 in. (1.5 mm).
- Install three bolts in tapered bushing (G), and tighten to 18 ft-lbf (25 N·m).
- Tap bushing, and re-torque. Repeat until bolts no longer turn at 18 ft-lbf (25 N·m).
- Install and tighten auger drive belts (J) as follows:

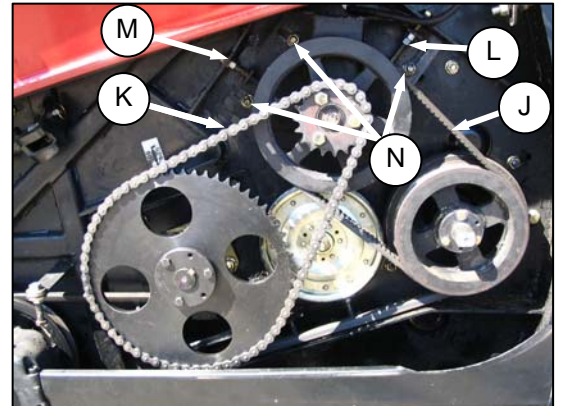

- Position auger drive belts (J) as shown.
- Locate chain (K) onto small sprocket.
- Turn adjuster bolt (L) to tighten chain. Deflection at (K) should be 1/4 in. (6 mm).
- Tighten jam nut on adjuster bolt (L).
- Turn adjuster bolt (M) so that each belt deflects 3/16 in. (4 mm) at mid-span when a load of 8–12 lbf (35–40 N) is applied to each belt.
- Tighten jam nut on adjuster bolt (M), and the three bolts (N).

(continued next page)

SECTION 7 MAINTENANCE AND SERVICING

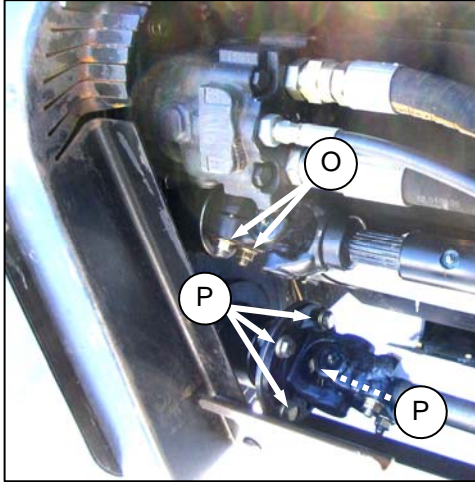

- g. Slide upper roll driveline onto gearbox as shown. Install and tighten two bolts and nuts (O). Torque to 75 ft·lbf (102 N·m).
- h. Attach lower roll driveline flange onto gearbox flange using four bolts and nuts (P).
- i. Adjust roll timing. Refer to Section 6.17.12.2 Roll Timing and Alignment.
- j. Clean off excess sealant from motor flange and gearbox face.
- k. Apply light coat of silicone to motor flange, and position motor on gearbox as shown until mounting holes are aligned, and pinion engages gear in gearbox.



- l. Install bolts (Q) and washers, and torque to 75 ft·lbf (102 N·m).
- m. Re-connect hoses to motor.
- n. Close all shields before engaging header.

SECTION 7 MAINTENANCE AND SERVICING

7.13.10 Gearbox Removal: A30-D

- a. Open shield covering conditioner drive.

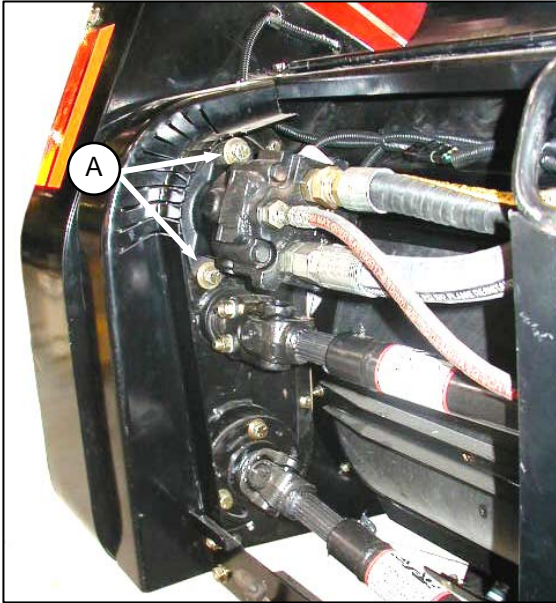

- b. Remove two bolts (A) securing motor to gearbox, and remove motor.

NOTE

It is not necessary to disconnect the motor hoses for this operation.

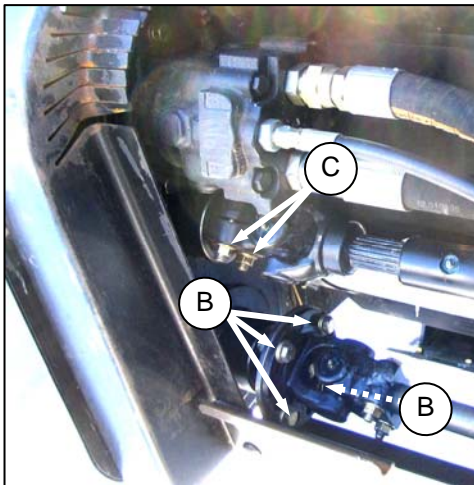

- c. Remove four nuts and bolts (B) from lower roll driveshaft, and swing driveline clear of gearbox.
d. Remove two nuts and bolts (C) from upper roll shaft at gearbox, and pull driveline clear of gearbox.
e. Open LH endshield.

- f. Remove auger drive chain (D) from small sprocket as follows:

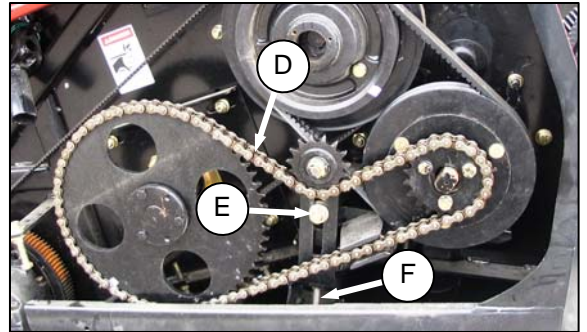

1. Loosen nut (E) on idler sprocket support.
2. Turn adjuster bolt (F) to loosen chain (D).
3. Remove chain from small sprocket.

- g. Remove V-belts from drive pulley as follows:

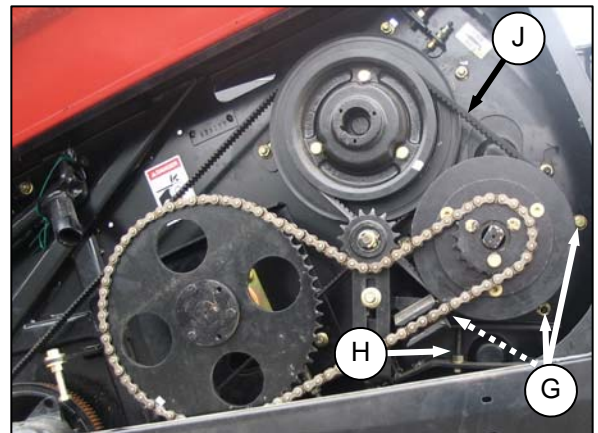

1. Loosen three bolts (G).
2. Loosen jam nut on adjuster bolt (H).
3. Turn adjuster bolt (H) to loosen auger drive belts (J).
4. Remove belts (J) from drive pulley.

(continued next page)

SECTION 7 MAINTENANCE AND SERVICING

h. Remove auger drive pulley (K) as follows:

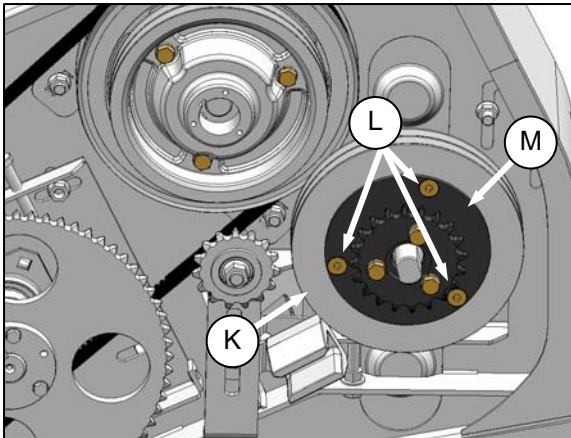

1. Remove three bolts (L) from hub (M), and remove hub and sprocket.

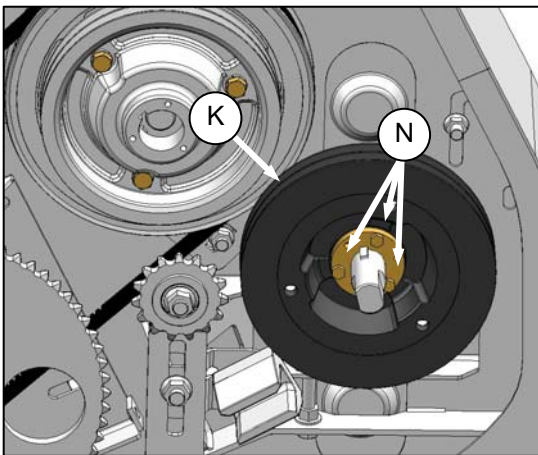

2. Remove three bolts (N) from the tapered bushing.
3. Install bolts in two threaded holes in bushing, and tighten to release bushing.
4. Remove pulley (K), bushing, and key.

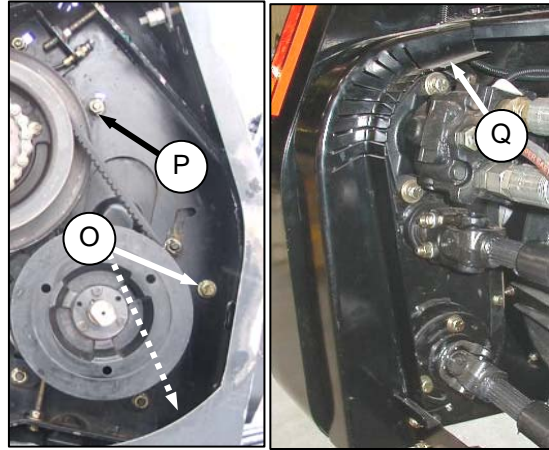

- i. Remove two bolts (O), and nut and bolt (P) attaching channel (Q) to endsheet, and remove channel (Q).

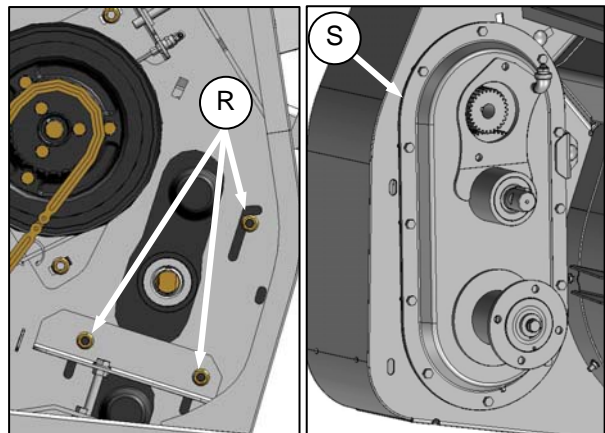

- j. Remove three flanged lock nuts (R) that secure gearbox (S) to header endsheet, and remove gearbox.

SECTION 7 MAINTENANCE AND SERVICING

7.13.11 Gearbox Installation: A30-D

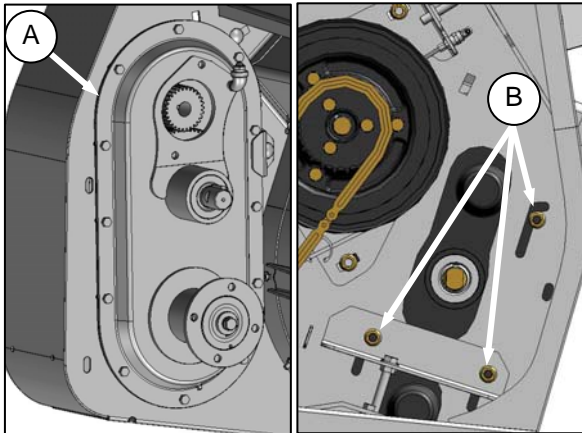

- Position gearbox (A) as shown, picking up the three holes in the endsheet.
- Install three flanged locknuts at (B) but do not tighten.

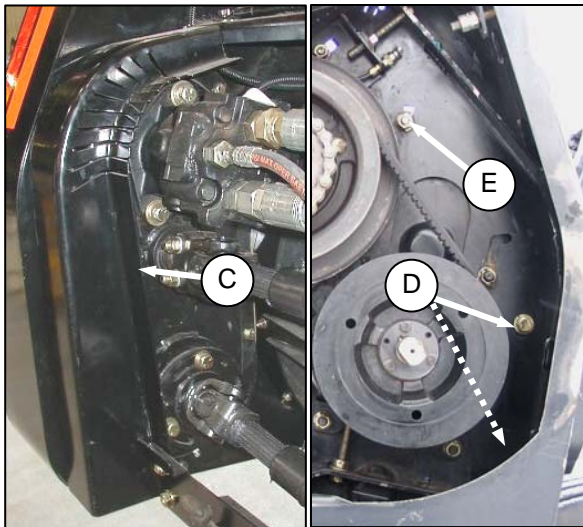

- Position channel (C) as shown above, picking up the three holes in the endsheet.
- Install bolts (D) in the lower two holes, and bolt (E) and nut in the upper hole, and tighten. Install bolt (E) from backside.
- Tighten hardware.

- Install drive pulley (F) as follows:

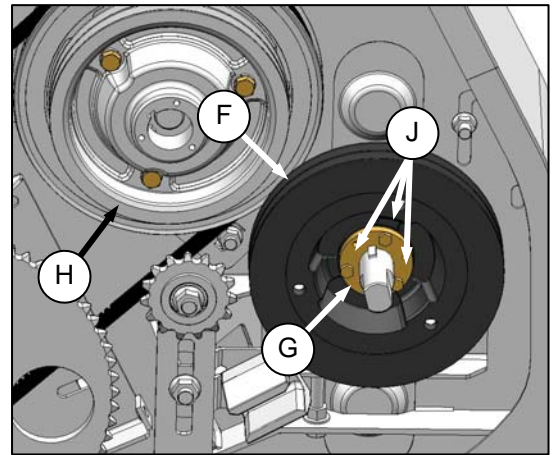

- Slide pulley (F) onto shaft with key.
- Install tapered bushing (G) onto shaft, ensuring holes are aligned with holes in pulley.
- Align pulley (F) and countershaft pulley (H) faces to within .06 in. (1.5 mm).
- Install three bolts (J) in tapered bushing (G), and tighten to 18 ft-lbf (25 N·m).
- Tap bushing and re-torque. Repeat until bolts no longer turn at 18 ft-lbf (25 N·m).

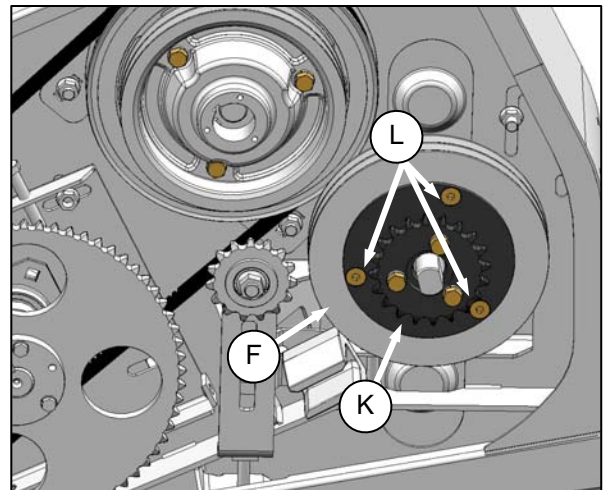

- Install hub and sprocket (K) with three bolts and nuts (L). Tighten to required torque.

(continued next page)

SECTION 7 MAINTENANCE AND SERVICING

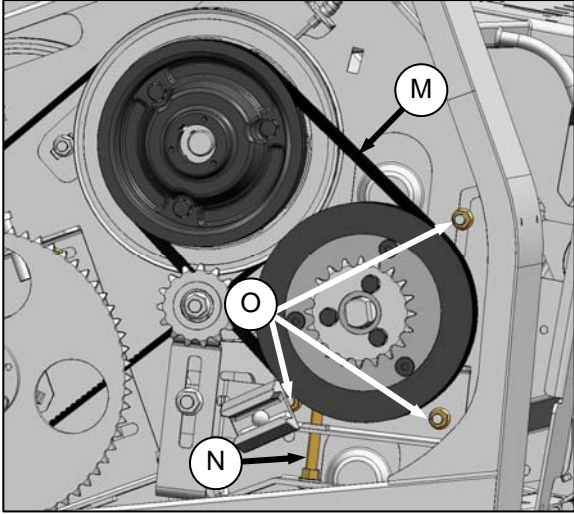

- h. Position auger drive belts (M) as shown above.
- i. Turn adjuster bolt (N) so that belts (M) deflect 3/16 in. (4 mm) at mid-span when a load of 8–12 lbf (35–40 N) is applied to each belt.
- j. Tighten bolts (O), and jam nut at (N).

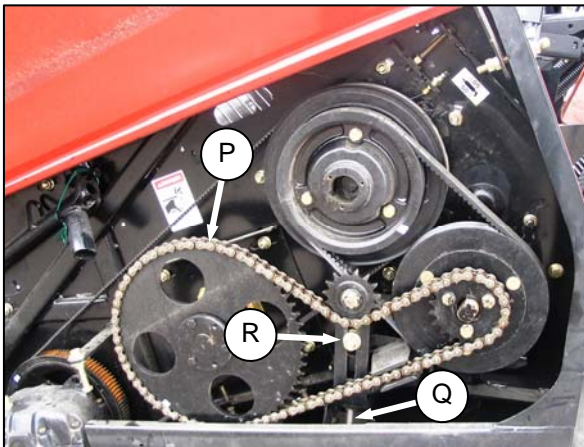

- k. Install drive chain (P) onto sprockets.
- l. Turn adjuster bolt (Q) to give 0.2 in. (5 mm) slack at mid-span of chain. Tighten nut (R) on idler sprocket support.
- m. Rotate auger, and check chain for slack at tightest point. Re-adjust position of idler sprocket to achieve required slack.

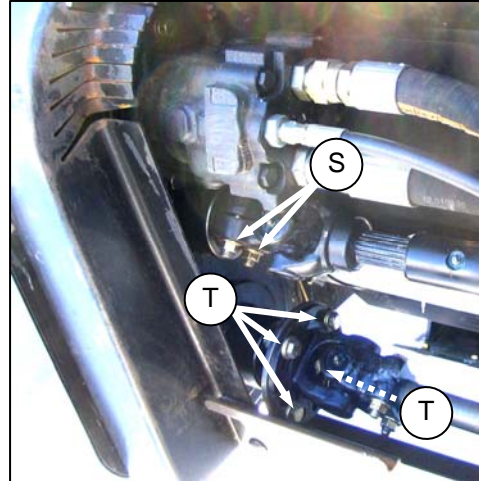

- n. Slide upper roll driveline onto gearbox as shown. Install and tighten two bolts and nuts (S). Torque to 75 ft-lbf (102 N·m).
- o. Attach lower roll driveline flange onto gearbox flange using four bolts and nuts (T).
- p. Adjust roll timing. Refer to Section 6.17.12.2 Roll Timing and Alignment.
- q. Clean off excess sealant from motor flange and gearbox face.
- r. Apply light coat of silicone to motor flange, and position motor on gearbox as shown until mounting holes are aligned, and pinion engages gear in gearbox.

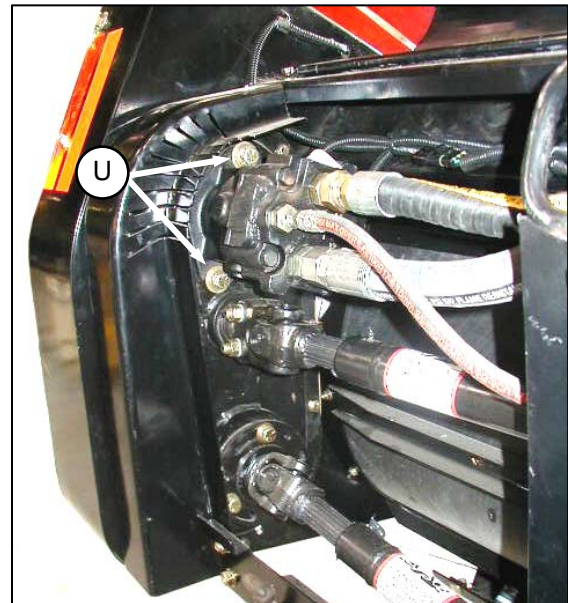

- s. Install bolts (U) and washers, and torque to 75 ft-lbf (102 N·m).
- t. Re-connect hoses to motor.
- u. Close all shields before operating machine.

SECTION 7 MAINTENANCE AND SERVICING

7.13.12 Gearbox Removal: A40-D

- a. Open shield covering conditioner drive.

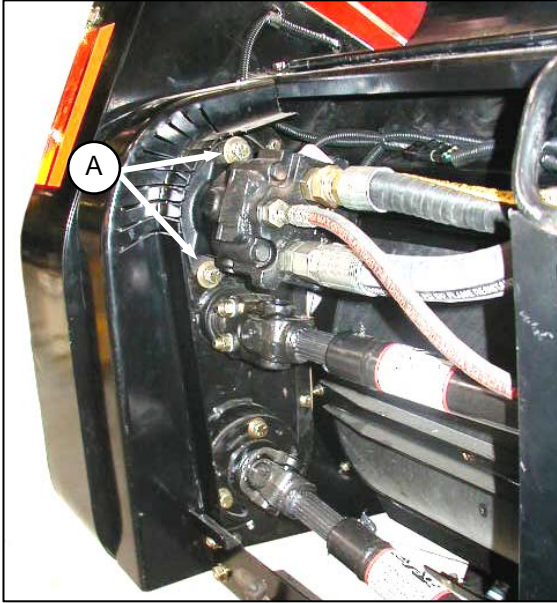

- b. Remove two bolts (A) securing motor to gearbox, and remove motor.

NOTE

It is not necessary to disconnect the motor hoses for this operation.

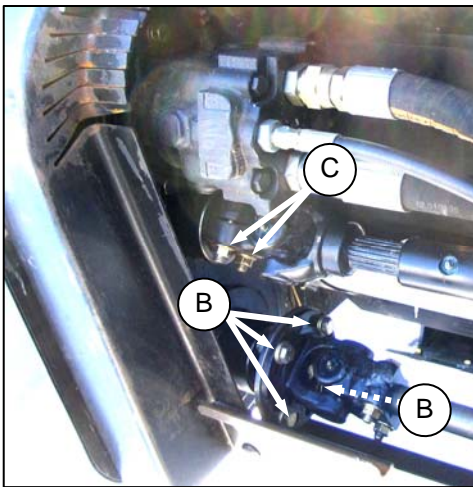

- c. Remove four nuts and bolts (B) from the lower roll driveshaft, and swing driveline clear of gearbox.
- d. Remove two nuts and bolts (C) from the upper roll shaft at the gearbox, and pull driveline clear of gearbox.

- e. Open endshield on the LH side of the header.

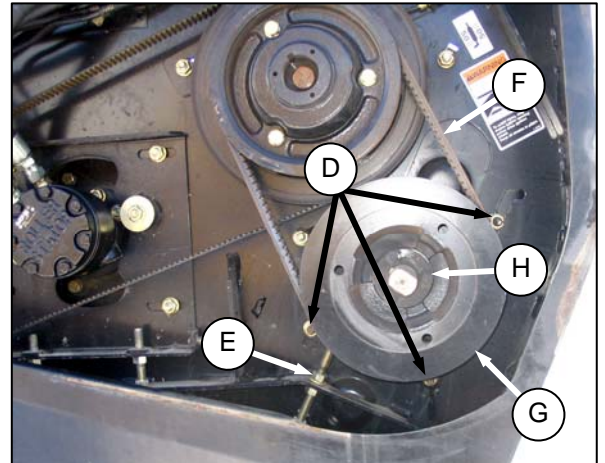

- f. Loosen three nuts (D) and jam nut on adjuster bolt (E).
- g. Turn adjuster bolt (E) so that drive belts (F) can be slipped off pulley (G).
- h. Remove sickle drive pulley (G) as follows:
1. Remove three bolts from the tapered bushing (H) in pulley (D).
 2. Install bolts in two threaded holes in bushing, and tighten to release bushing.
 3. Remove pulley, bushing, and key.

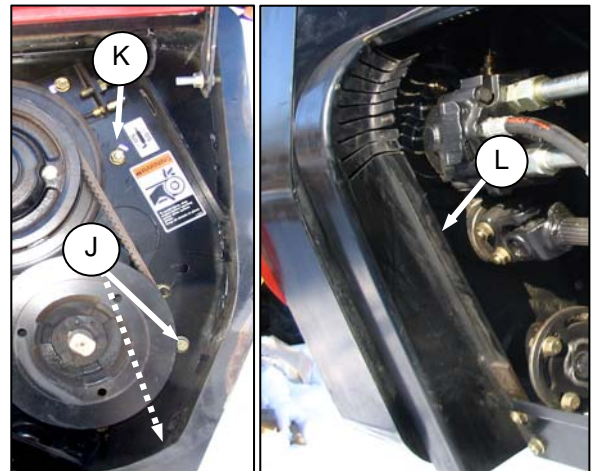

- i. Remove two bolts (J), and nut and bolt (K) attaching channel (L) to endsheet, and remove channel (L).

(continued next page)

SECTION 7 MAINTENANCE AND SERVICING

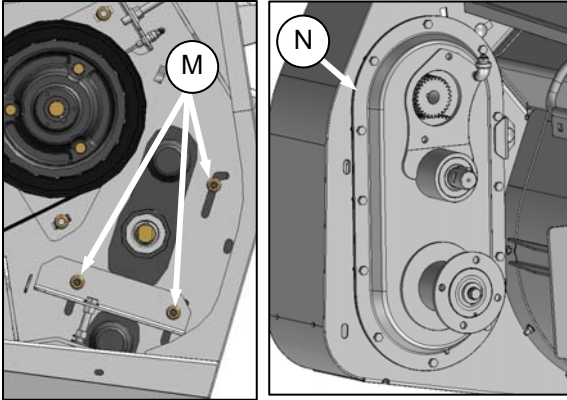

- j. Remove three flanged lock nuts (M) that secure gearbox (N) to header endsheet, and remove gearbox.

7.13.13 Gearbox Installation: A40-D

- Position gearbox (N) (as shown above) picking up the three holes in the endsheet.
- Install three flanged locknuts (M), but do not tighten.

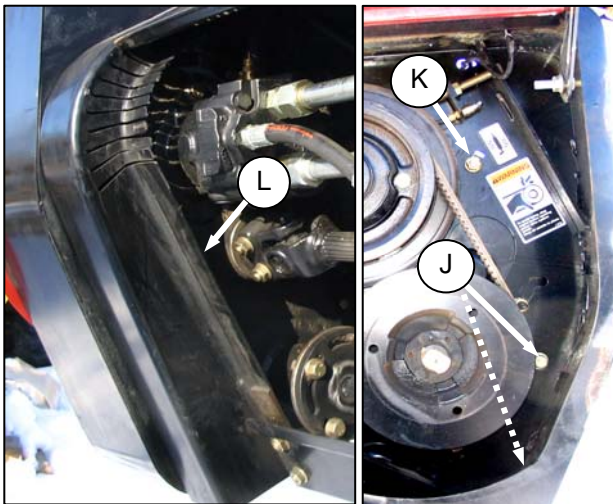

- Position channel (L), picking up the three holes in the endsheet.
- Install bolts at (J) in the lower two holes, and bolt and nut (K) in the upper hole, and tighten.
- Tighten hardware.

- f. Install drive pulley (G) as follows:

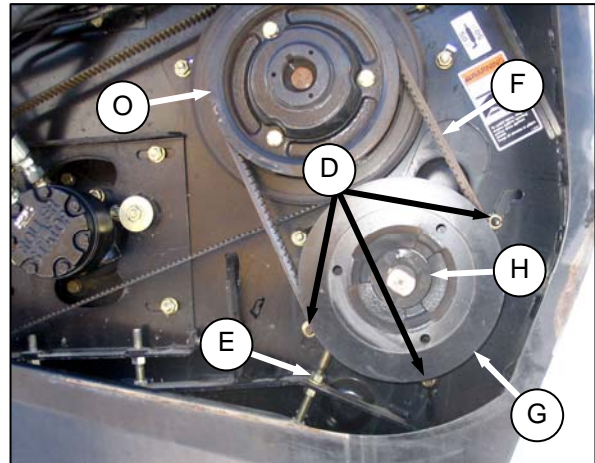

- Slide pulley (G) onto shaft with key.
 - Install tapered bushing (H) onto the shaft, ensuring holes are aligned with holes in pulley.
 - Align faces of pulley (G) and countershaft pulley (O) to within .06 in. (1.5 mm).
 - Install three bolts in tapered bushing (H), and tighten to 18 ft-lbf (25 N·m).
 - Tap bushing and re-torque. Repeat until bolts no longer turn at 18 ft-lbf (25 N·m).
- Position belts (F) on pulleys (G) and (O).
 - Turn adjuster bolt (E) to move pulley (G) until a force of 8–12 lbf (35–50 N) on each belt at mid-span deflects the belt (F) 0.16 in. (4 mm).
 - Tighten jam nut at (E), and three nuts (D).

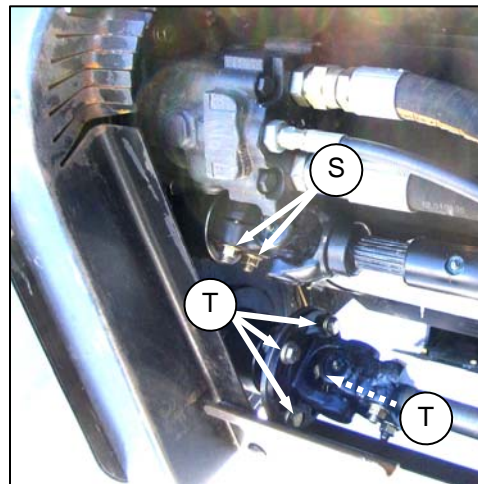

- Slide upper roll driveline onto gearbox as shown. Install and tighten two bolts and nuts (S). Torque to 75 ft-lbf (102 N·m).
- Attach lower roll driveline flange onto gearbox flange using four bolts and nuts (T).

(continued next page)

SECTION 7 MAINTENANCE AND SERVICING

- l. Adjust roll timing. Refer to Section 6.17.12.2 Roll Timing and Alignment.
- m. Clean off excess sealant from motor flange and gearbox face.
- n. Apply light coat of silicone to motor flange, and position motor on gearbox as shown until mounting holes are aligned, and pinion engages gear in gearbox.
- o. Install bolts removed in step b. (A) and washers, and torque to 75 ft·lbf (102 N·m).
- p. Re-connect hoses to motor.
- q. Close all shields before operating machine.

SECTION 7 MAINTENANCE AND SERVICING

7.14 WHEELS, TIRES, AND HITCH: PULL-TYPE



CAUTION

To avoid personal injury, before servicing header/mower conditioner or opening drive covers, follow procedures in Section 7.1 PREPARATION FOR SERVICING.

7.14.1 Wheel Bolts

IMPORTANT

Check and tighten wheel bolts after the first hour of operation, and every 100 hours thereafter.

IMPORTANT

Whenever a wheel is removed and re-installed, check torque after one hour of operation. Maintain 120 ft-lbf (160 N·m) torque.

7.14.2 Wheel Removal

- Lower header to the ground.
- Retrieve jack (5000 lb capacity) from storage position on APT.

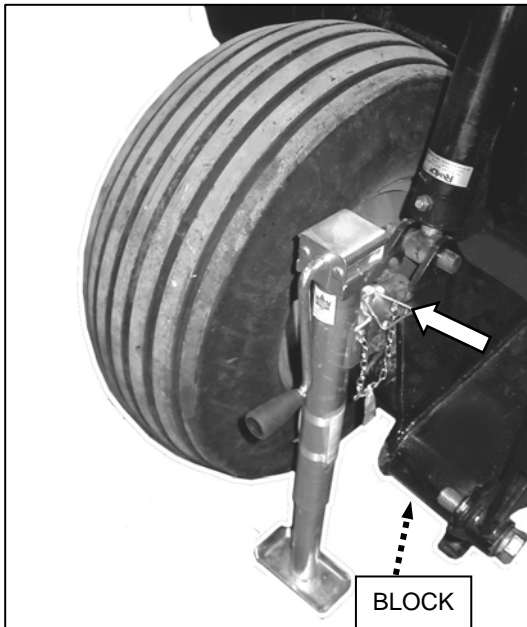

- Position jack on mount provided on frame leg as shown, and raise tire just off the ground. Place block under frame leg.
- Remove wheel bolts.
- Remove wheel.

7.14.3 Wheel Installation



CAUTION

When installing wheel be sure to use the holes that are countersunk to match bolt head profile.

The uncountersunk holes do not seat the bolts correctly.

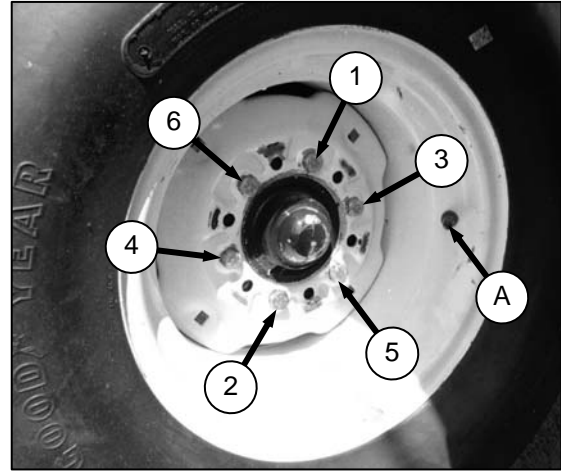

IMPORTANT

Follow proper bolt tightening sequence shown. Be sure valve stem (A) points away from wheel support.

- Position wheel on spindle, and install bolts. Partially tighten.
- Remove blocks, and raise jack until tire contacts the ground.
- Torque bolts to 120 ft-lbf (160 N·m) in accordance with tightening sequence shown.
- Raise jack completely, remove from leg and store on APT.

SECTION 7 MAINTENANCE AND SERVICING

7.14.4 Tire Inflation

Check tire pressure daily. Maintain 30 psi (207 kPa).



WARNING

- Service tires safely.



- A tire can explode during inflation and cause serious injury or death.
- Do not stand over tire. Use a clip-on chuck and extension hose.
- Never increase air pressure beyond 35 psi (241 kPa) to seat the bead on the rim.
- Replace the tire if it has a defect.
- Replace a wheel rim, which has cracks, wear or severe rust.
- Never weld a wheel rim.
- Never use force on an inflated or partially inflated tire.
- Make sure the tire is correctly seated before inflating to operating pressure.
- If the tire is not in correct position on the rim, or is too full of air, the tire bead can loosen on one side, causing air to leak at high speed and with great force. An air leak of this nature can thrust the tire in any direction, endangering anyone in the area.
- Make sure all the air is removed from a tire before removing the tire from a rim.
- Do not remove, install or make repairs to a tire on a rim unless you have the proper equipment and experience to perform the job.
- Take the tire and rim to a qualified tire repair shop.

SECTION 7 MAINTENANCE AND SERVICING

7.15 SKID SHOE WEAR PLATE REPLACEMENT

Skid shoes are equipped with replaceable wear plates that can be reversed for increase service life. It is recommended that wear plates be replaced when the skid shoe weldment becomes exposed.

- a. Raise header, and engage lift cylinder stops.



CAUTION

Stop engine, and remove key from ignition before leaving Operator's seat for any reason. A child or even a pet could engage an idling machine.

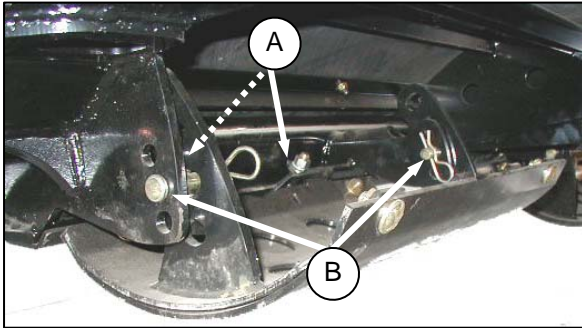

- b. Remove bolts (A), and clips from forward edge of skid shoe.

NOTE

Use a socket and ratchet wrench to access the nuts.

- c. Remove clevis pins (B), and disengage tabs on skid shoe from slots in cutterbar.

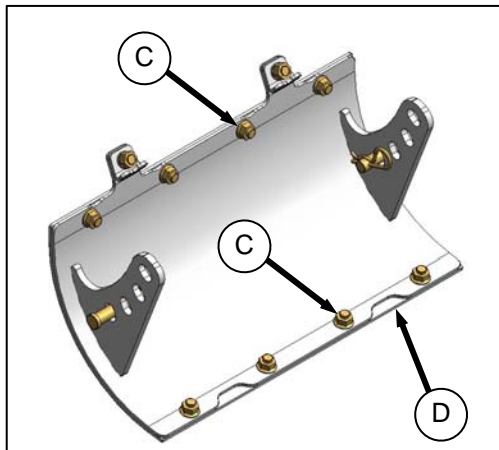

- d. Remove eight bolts (C), and remove wear plates (D).

- e. Position replacement wear plate (D) as shown. (The same wear plate can be re-installed, but in the reverse position).
- f. Secure wear plate with bolts and nuts (C).

IMPORTANT

If bolt heads are worn down, replace with new 1/2 in. x 1 carriage bolts.

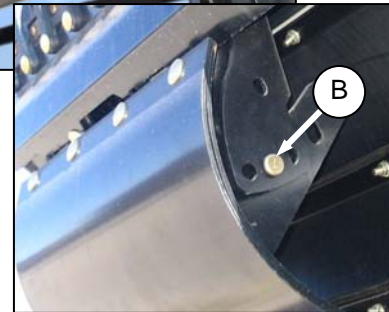
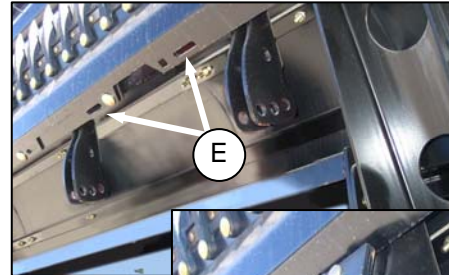

- g. Insert tabs on skid shoe into slots (E) on cutterbar at inboard mounting locations on frame, and secure with clevis pin (B).

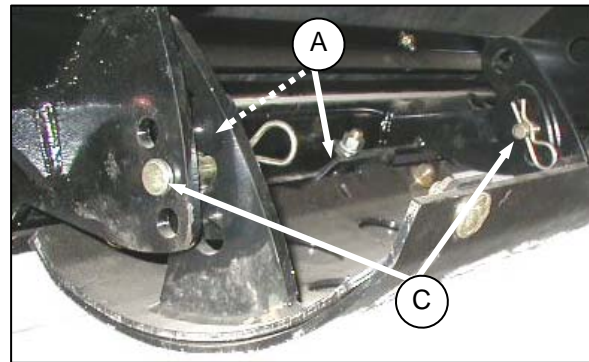

- h. Re-install clips (A) with bolts and nuts removed at step b. to secure skid shoe to cutterbar.

NOTE

Use a socket and ratchet wrench to access the nuts.

- i. Remove clevis pin, adjust skid shoe to desired height, and re-install two clevis pins. Secure with lynch pins.

SECTION 7 MAINTENANCE AND SERVICING

7.16 GAUGE ROLLERS

Gauge rollers can be removed for replacement or repair. Proceed as follows to remove gauge rollers:

Removal:

- Raise header, and engage lift cylinder stops.



CAUTION

Stop engine, and remove key from ignition before leaving Operator's seat for any reason. A child or even a pet could engage an idling machine.

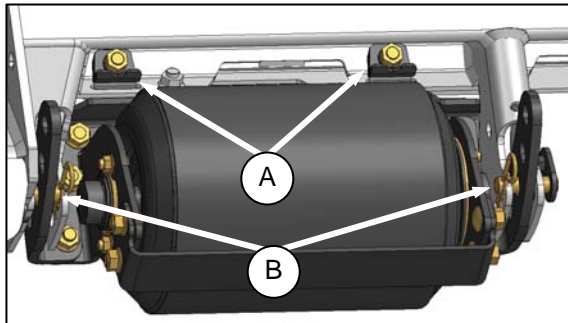

- Remove bolts and clips (A) from forward edge of gauge roller assembly.

NOTE

Use a socket and ratchet wrench to access the nuts.

- Remove hairpins on pins (B).
- Support gauge roller, and remove pins (B).
- Disengage tabs on mounting plate from slots in cutterbar to remove roller assembly.

Installation:

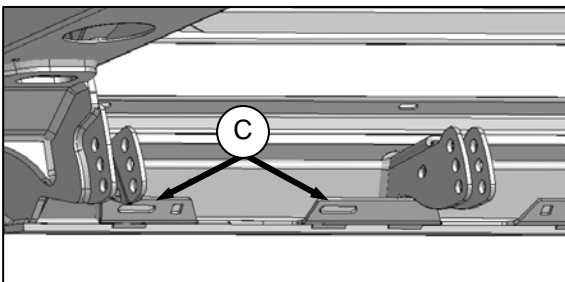

- Position gauge roller assembly below cutterbar, and insert tabs on roller assembly into slots (C) in frame. Secure with two pins (B) at lowest position.
- Attach clips (A) with bolts and nuts to secure roller assembly to cutterbar.

NOTE

Use a socket and ratchet wrench to access the nuts.

- Tighten nuts.

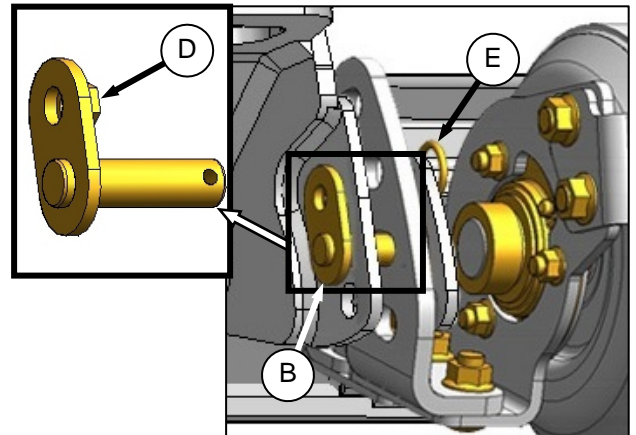

- Remove pins (B), and adjust rollers to desired height. Re-install the two pins (B).
- Ensure that nut (D) on each pin registers in adjacent hole in support bracket.
- Secure pins with hairpins (E).

7.17 ELECTRICAL

- Use electrical tape and wire clips as required to prevent wires from dragging or rubbing.
- Keep lights clean, and replace defective bulbs.
- To replace light bulbs:

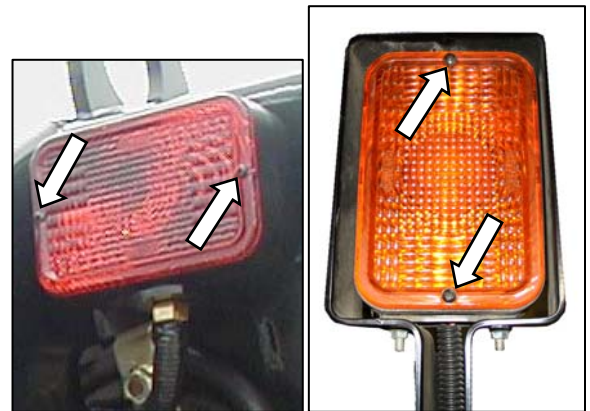

PT TAIL LIGHT

SP HAZARD LIGHT

Bulb Part No. - Trade #1156

- Using a Phillips screwdriver, remove screws from fixture, and remove plastic lens.
- Replace bulb, and re-install plastic lens and screws.

SECTION 7 MAINTENANCE AND SERVICING

7.18 MAINTENANCE SCHEDULE

The following maintenance schedules list periodic maintenance procedures, and are organized by service intervals. Regular maintenance is the best insurance against early wear and untimely breakdowns. Following this schedule will increase machine life. For detailed instructions, refer to the specific headings in Section 7 MAINTENANCE AND SERVICING.

Recommended service intervals are in **hours of operation**. Where a service interval is given in more than one time frame, e.g. 100 hours or Annually, service the machine at whichever interval is reached first.

IMPORTANT

Recommended intervals are for average conditions. Service the machine more often if operated under adverse conditions (severe dust, extra heavy loads, etc.).



CAUTION

Carefully follow safety messages given under Section 7.2 RECOMMENDED SAFETY PROCEDURES.

7.18.1 Self-Propelled Mower Conditioner

NOTE

The following service schedule is only applicable to the Auger Header. Refer to your Windrower Operator's Manual for windrower maintenance.

7.18.1.1 Break-In Inspection: Self-Propelled

HOURS	ITEM	CHECK	REFERENCE
5	Hardware	Torque	Section 7.3.1
5, 25, and 50	Auger Drive Belt	Tension	Sections 7.11.3 and 7.11.4
	Reel Drive Belt		Section 7.9.2
	Sickle Drive Belt		Sections 7.8.9, 7.8.10, and 7.8.11
10	Auger Drive Chain	Tension / Lubrication	Sections 7.11.1 and 7.11.2
	Reel Drive Chain		Section 7.9.1
	Sickle Drive Box Mounting Bolts	Torque	200 ft-lbf (270 N·m) Section 7.8.13

7.18.1.2 Interval Maintenance: Self-Propelled

INTERVAL	SERVICE	
FIRST USE	Refer To Section 7.18.1.1 Break-In Inspection: Self-Propelled	
100 HOURS OR ANNUALLY *	1. Check Conditioner Drive Gearbox Lubricant Level. 2. Check Sickle Drive Box Lubricant Level.	3. Check Sickle Drive Box Mounting Bolt Torques.
END OF SEASON	Refer To Section 6.19 STORAGE.	
10 HOURS OR DAILY	1. Check Hydraulic Hoses And Lines For Leaks. 2. Oil Sickle (Except In Sandy Conditions). 3. Check Sickle Sections, Guards, and Hold-Downs.	4. Oil Reel Drive Chain (except A40-D). 5. Oil Auger Drive Chain (except A40-D). 6. Check Sickle Drive Box Bolt Torque (First 10 Hours Only; Every 100 Hours After).
25 HOURS	1. Grease Sickle Head.	
50 HOURS	1. Grease Reel Shaft Bearings. 2. Grease Auger Shaft Bearings. 3. Grease Auger Jack-Shaft Bearings (except A40-D). 4. Grease Conditioner Universal Shafts. 5. Grease Conditioner Shaft Bearings. 6. Grease Roll Pivots Bearing.	7. Grease Tine Tube Bearings (A40-D). 8. Grease Gauge Roller Bearings. 9. Change Sickle Drive Box Lubricant (First 50 Hours Only; Every 1000 Hours After). 10. Change Conditioner Drive Gearbox Lubricant (First 50 Hours Only; Every 1000 Hours After).
1000 HOURS OR 3 YEARS	1. Change Sickle Drive Box Lubricant.	2. Change Conditioner Drive Gearbox Lubricant.

SECTION 7 MAINTENANCE AND SERVICING

7.18.1.3 Maintenance Record: Self-Propelled

Self-Propelled Windrower Header															
	ACTION:	✓ - Check	◆ - Lubricate							▲ - Change					
MAINTENANCE RECORD	Hour Meter Reading														
	Date														
	Serviced By														
BREAK-IN		Refer To Section 7.18.1.1 Break-In Inspection: Self-Propelled													
100 HOURS OR ANNUALLY															
✓	Conditioner Drive Gearbox Lube Level														
◆	Wheel Hub Bearings														
✓	Sickle Drive Box Bolt Torque														
✓	Sickle Drive Box Lubricant Level														
END OF SEASON		Refer To Section 6.19 STORAGE													
10 HOURS OR DAILY		NOTE: A RECORD OF DAILY MAINTENANCE IS NOT NORMALLY REQUIRED BUT IS AT THE OWNER/OPERATOR'S DISCRETION.													
◆	Auger Drive Chain (except A40-D)														
✓	Hydraulic Hoses and Lines														
✓	Hydraulic Oil Level														
◆	Reel Drive Chain (except A40-D)														
◆	Sections, Guards and Hold-downs														
✓	Sickle Assembly														
✓	Sickle Drive Box Bolt Torque - First 10 Hours Only														
25 HOURS															
◆	Sickle Head														
50 HOURS															
◆	Auger Drive Jackshaft Bearings (except A40-D)														
◆	Auger Shaft Bearings														
◆	Gauge Roller Bearings														
◆	Main Driveshaft Bearings														
◆	Tine Bar Bearings (A40-D)														
◆	Reel Shaft Bearings														
▲	Conditioner Gearbox Oil - First 50 Hours Only														
◆	Conditioner Universal Shafts														
◆	Roll Pivots														
◆	Conditioner Shaft Bearings														
◆	Sickle Drive Cross-Shaft														
▲	Sickle Drive Box Oil - First 50 Hours Only														
1000 HOURS OR 3 YEARS															
▲	Conditioner Drive Gearbox Lubricant														
▲	Sickle Drive Box Lubricant														

SECTION 7 MAINTENANCE AND SERVICING

7.18.2 Pull-Type Mower Conditioner

7.18.2.1 Break-In Inspection: Pull-Type

HOURS	ITEM	CHECK	REFERENCE
1	Wheel Bolts	Torque	120 ft-lbf (160 N-m) Section 7.14.1
	Steering Cylinder Clevis and Stroke Control		52 ft-lbf (72 N-m)
5, 25, 50	Auger Drive Belt	Tension	Sections 7.11.3 and 7.11.4
	Reel Drive Belt		Section 7.9.2
	Sickle Drive Belt		Sections 7.8.9 and 7.8.10
5	Hardware	Torque	Section 7.3.1
10	Auger Drive Chain	Tension/ Lubricate	Sections 7.11.1 and 7.11.2
	Reel Drive Chain		Section 7.9.1
	Sickle Drive Box Mounting Bolts	Torque	200 ft-lbf (270 N-m) Section 7.8.13

7.18.2.2 Interval Maintenance: Pull-Type

INTERVAL	SERVICE	
FIRST USE	Refer To Section 7.18.2.1 Break-In Inspection: Pull-Type	
100 HOURS OR ANNUALLY *	<ol style="list-style-type: none"> 1. Check Conditioner Drive Gearbox Lubricant Level. 2. Check Sickle Drive Box Lubricant Level. 3. Check Sickle Drive Box Mounting Bolt Torques. 	<ol style="list-style-type: none"> 4. Check Wheel Bolt Torques. 5. Grease Wheel Hub Bearings. 6. Change Hydraulic Oil Filter (First 100 Hours Only; Every 250 Hours After).
END OF SEASON	Refer To Section 6.19 STORAGE.	
10 HOURS OR DAILY	<ol style="list-style-type: none"> 1. Check Hydraulic Oil Level. 2. Check Hydraulic Hoses And Lines For Leaks. 3. Oil Sickle (Except In Sandy Conditions). 4. Check Sickle Sections, Guards, and Hold Downs. 	<ol style="list-style-type: none"> 5. Oil Reel Drive Chain. 6. Oil Auger Drive Chain. 7. Check Tire Pressure. 8. Check Sickle Drive Box Bolt Torque (First 10 Hours Only; Every 100 Hours After).
25 HOURS	<ol style="list-style-type: none"> 1. Grease Sickle Head. 	
50 HOURS	<ol style="list-style-type: none"> 1. Grease APT Pivot. 2. Grease Reel Shaft Bearings. 3. Grease Auger and Jack-Shaft Bearings. 4. Grease Conditioner Drivelines. 5. Grease Conditioner Shaft Bearings. 6. Grease Roll Pivots Bearing. 7. Grease Frame-To-Header Pivots. 	<ol style="list-style-type: none"> 8. Grease Lower Float Link Bushings. 9. Grease Gauge Roller Bearings. 10. Change Sickle Drive Box Lubricant. (First 50 Hours Only; Every 1000 Hours After). 11. Change Conditioner Drive Gearbox Lubricant (First 50 Hours Only; Every 1000 Hours After).
250 HOURS	Change Hydraulic Oil Filter.	
500 HOURS OR 3 YEARS	Change Hydraulic Oil.	
1000 HOURS OR 3 YEARS	<ol style="list-style-type: none"> 1. Change Sickle Drive Box Lubricant. 	<ol style="list-style-type: none"> 2. Change Conditioner Drive Gearbox Lubricant.

* IT IS RECOMMENDED THAT ANNUAL MAINTENANCE BE DONE PRIOR TO START OF OPERATING SEASON.

SECTION 7 MAINTENANCE AND SERVICING

7.18.2.3 Maintenance Record: Pull-Type

Pull-Type Mower Conditioner													
	ACTION:	✓ - Check	⬇ - Lubricate	▲ - Change									
MAINTENANCE RECORD	Hour Meter Reading												
	Date												
	Serviced By												
FIRST USE		Refer To Section 7.18.2.1 Break-In Inspection: Pull-Type											
100 HOURS OR ANNUALLY													
▲	Hydraulic Oil Filter - First 100 H Only												
✓	Conditioner Drive Gearbox Lube Level												
✓	Wheel Bolt Torque												
⬇	Wheel Hub Bearings												
✓	Sickle Drive Box Bolt Torque												
✓	Sickle Drive Box Lubricant Level												
END OF SEASON		Refer To Section 6.19 STORAGE											
10 HOURS OR DAILY													
⬇	Auger Drive Chain												
✓	Hydraulic Hoses and Lines												
✓	Hydraulic Oil Level												
⬇	Reel Drive Chain												
⬇	Sections, Guards and Hold-Downs												
✓	Sickle Assembly												
✓	Sickle Drive Box Bolt Torque - First 10 H Only												
25 HOURS													
⬇	Sickle Head												
50 HOURS													
⬇	Auger Drive and Jackshaft Bearings.												
⬇	Frame-to-Header Pivot												
⬇	Gauge Roller Bearings												
⬇	Lower Float Link Bushings												
⬇	Main Driveshaft Bearings												
⬇	Reel Shaft Bearings												
▲	Conditioner Gearbox Oil - First 50 H Only												
⬇	Conditioner Drivelines												
⬇	Roll Pivots												
⬇	Sickle Drive Cross-Shaft												
⬇	Spring Pivots												
✓	Tire Pressure												
⬇	APT Pivot												
▲	Sickle Drive Box Oil - First 50 H Only												
250 HOURS													
▲	Hydraulic Oil Filter												
500 HOURS OR 3 YEARS													
▲	Hydraulic Oil												
1000 HOURS OR 3 YEARS													
▲	Conditioner Drive Gearbox Lubricant												
▲	Sickle Drive Box Lubricant												

NOTE: A RECORD OF DAILY MAINTENANCE IS NOT NORMALLY REQUIRED BUT IS AT THE OWNER/OPERATOR'S DISCRETION.

SECTION 8 TROUBLESHOOTING

8 TROUBLESHOOTING

8.1 WINDROWER PERFORMANCE

SYMPTOM	PROBLEM	SOLUTION	SECTION
Carryover of Crop On Reel.	Reel speed too fast.	Reduce reel speed (sprocket size).	6.17.3
Material Build-Up On Header Frame.	Auger speed too fast.	Reduce auger speed (sprocket size).	6.17.2
	Very light crop.	Reduce tractor/windrower rpm.	---
Insufficient Conditioning Of Stems.	Roll gap too large.	Decrease roll gap.	6.17.12.1
Leaves Damaged, Crushed Or Stripped Off Stems.	Reel speed too fast.	Reduce reel speed.	6.17.3
	Roll gap too small.	Increase roll gap.	6.17.12.1
	Rolls improperly timed.	Adjust roll timing.	6.17.12.2
Slow Crop Drying.	Rolls not crimping crop sufficiently.	Decrease roll gap.	6.17.12.1
	Crop is spread too narrow.	Adjust forming shields for wider swath.	6.17.14
	Crop is bunched in windrow.	Adjust forming shields/baffle.	
Excessive Drying Or Bleaching Of Crop.	Excessive crimping.	Increase roll gap.	6.17.12.1
	Crop is spread too wide in windrow.	Adjust forming shields.	6.17.14
Leaving Small Strip Of Flattened, Uncut Material.	Crowding of the uncut material.	Steer tractor slightly away from uncut crop.	---
	Reel position incorrect.	Move reel forward and down.	6.17.5
	Sickle sections or guards are worn or broken.	Replace worn or broken parts.	7.8.1 & 7.8.7
Long Stubble In Down Crop.	Cutting height too high.	Lower cutting height with skid shoes.	6.17.8
	Ground speed too fast.	Slow down.	---
	Header angle too flat for guards to pick up down crop.	Increase header angle.	6.17.9
	Reel position incorrect.	Move reel forward and down.	6.17.5
	Tine aggressiveness too low.	Rotate cam clockwise (viewed from RH end) for more aggressive tine action.	6.17.6

SECTION 8 TROUBLESHOOTING

SYMPTOM	PROBLEM	SOLUTION	SECTION
Pulling Material By The Roots Or Tall Material Leaning Into Machine.	Ground speed too slow.	Increase ground speed.	---
	Reel position incorrect.	Move reel forward and down.	6.17.5
Ragged Or Uneven Cutting Of Crop.	Bent or misaligned guards causing poor shearing action.	Align guards for proper shearing action.	7.8.7
	Bent sickle causing binding.	Straighten bent sickle. Check alignment, and if necessary, replace.	7.8.2
	Ground speed too fast.	Slow down. Ground speed should not exceed 8 mph (13 km/h).	---
	Header angle too flat for guards to pick up down crop.	Increase header angle.	6.17.9
	Header flotation too light, causing bouncing.	Adjust to heavier float setting.	6.17.10
	PTO speed too slow (pull-type).	Maintain proper RPM on PTO. Check for proper match of pump and gear-drive at PTO.	5.1
	Reel drive chain too loose (except A40-D).	Increase chain tension.	7.9.1
	Reel position incorrect.	Move reel forward and down.	6.17.5
	Relief valve pressure too low.	Replace valve.	See Dealer
	Sickle drive belt too loose.	Increase belt tension.	7.8.9 to 7.8.11
	Sickle sections or guards are worn or broken.	Replace worn or broken parts.	7.8.1 & 7.8.7
Conditioner Plugging.	Ground speed too fast.	Slow down.	---
	Roll gap too large for proper feeding.	Decrease roll gap.	6.17.12.1
	Roll gap too small in thick stemmed cane-type crops.	Increase roll gap.	
	Rolls improperly timed.	Adjust roll timing.	6.17.12.2
Sickle Plugging.	Bent or misaligned guards.	Align guards.	7.8.7
	Extremely thick or wet undergrowth.	Raise cutting height to clear undergrowth.	6.17.8
		Consider use of stub guards.	9.5
	Header flotation too heavy.	Adjust to lighter float setting.	6.17.10
	PTO speed too slow (pull-type).	Maintain proper RPM on PTO. Check for proper match of pump and gear-drive at PTO.	5.1

SECTION 8 TROUBLESHOOTING

SYMPTOM	PROBLEM	SOLUTION	SECTION
Sickle Plugging (cont'd).	Wet undergrowth.	Cut when undergrowth is dry.	---
	Reel position incorrect.	Move reel back and down (close to guards).	6.17.5
	Sickle drive belt too loose.	Adjust belt tension.	7.8.9 to 7.8.11
	Sickle hold-downs improperly adjusted.	Adjust hold-downs so sickle works freely.	7.8.8
	Sickle sections or guards are worn or broken.	Replace worn or broken parts.	7.8.1 & 7.8.7
Uneven Formation And Bunching Of Windrow.	Auger to stripper clearance too wide.	Adjust auger to stripper bars clearance.	6.17.4
	Forming shields improperly adjusted - fluffer too low.	Adjust forming shields, raise fluffer.	6.17.14
	Fluffer bypassing or dragging crop.	Adjust fluffer for proper crop control.	
	Reel not feeding properly in heavy crops.	Decrease ground speed.	---
	Roll gap too large.	Adjust roll gap.	6.17.12.1
	Conditioner running too slow.	Maintain rated knife/ conditioner speed.	5.1 & 5.2
	Uneven crop flow across auger.	Remove front stripper bar or stripper bar extension if installed.	7.11.7
	Excessive center feeding of crop.	Remove front stripper bar extensions if installed.	
	Build up of crop at ends of rolls, especially in tall crops.	Add front stripper bar extension	
Uneven Windrow Formation In Light Crop.	Rear of feed pan too low.	Raise rock drop tine bar.	6.17.11
Reel Causes Seed Loss (e.g. Grass Seed).	Reel speed too fast.	Adjust flow control on tractor/windrower.	6.17.3
	Header angle too steep, causing tines to contact ground.	Flatten header angle, and check header float.	6.17.9 & 6.17.10
	Reel not correctly positioned.	Lower reel speed, move reel rearward, as close as possible to auger, and downward as close as possible to knife and pan.	6.17.3 & 6.17.5
Auger Plugging In Heavy Grass Seed.	Poor crop flow across auger.	Remove lower stripper bar and middle stripper bar if necessary.	7.11.7

SECTION 8 TROUBLESHOOTING

SYMPTOM	PROBLEM	SOLUTION	SECTION
Plugging At Delivery Opening In Heavy Grass Seed.	Opening too narrow.	Move pan extensions to widest position.	6.17.17
Grass Seed Windrow Too Wide or Too Narrow.	Pan extensions not adjusted properly.	Adjust pan extensions.	

8.2 MECHANICAL

SYMPTOM	PROBLEM	SOLUTION	SECTION
Auger and/or Conditioner Rolls Damaged By Stones.	Feed pan doesn't allow stones to fall through.	Lower rock-drop tines.	6.17.11
Excessive Breakage Of Sickle Sections Or Guards.	Ground speed too high in stony conditions.	Reduce ground speed.	---
	Cutting height too low in stony conditions.	Raise cutting height with skid shoes.	6.17.8
	Header angle too steep in stony conditions.	Decrease header angle.	6.17.9
	Header flotation too heavy in stony conditions.	Adjust to lighter float setting.	6.17.10
	Sickle speed too slow.	Maintain proper RPM on PTO. Check for proper match of pump and gear-drive at PTO.	5.1
	Guards, sickle and hold-downs misaligned.	Straighten guards, align hold-downs.	7.8.7 & 7.8.8
Excessive Heating Of Hydraulic Oil.	Relief pressure too low.	Replace relief valve.	See Dealer
Header Stalling In Extremely Tall, Heavy Crop (6+ Tons Per Acre).	Insufficient crop clearance at rear of feed pan.	Lower rock drop tines (rear of header pan).	6.17.11
		Remove rubber fingers from auger at delivery opening.	7.11.6
		Increase roll gap.	6.17.12.1
	Feeding aids for shorter, lighter crop impede flow of heavy or thick stemmed crops (cane, sudan grass etc.).	Remove front set of stripper bars.	7.11.7
Header Turns While Unloaded But Slows Or Stops When Starting To Cut.	Low reservoir oil level.	Add oil to reservoir.	7.7.2.3
	Defective motor.	Repair motor.	See Dealer
	Defective O-ring inside relief valve.	Replace relief valve.	
	Defective pump.	Repair pump.	
	Defective relief valve.	Repair relief valve.	
	PTO slipping on tractor.	Repair tractor PTO system.	

SECTION 8 TROUBLESHOOTING

SYMPTOM	PROBLEM	SOLUTION	SECTION
Knocking In Sickle Drive.	Worn needle bearing in sickle head.	Replace.	7.8.4
	Worn sickle head pin.		7.8.3
	Incorrect end guards.	Replace with special end guards.	7.8.7
Header Turns While Unloaded But Slows Or Stops When Starting To Cut.	Cold oil in system.	Reduce ground speed until oil reaches operating temperature.	---
Sickle Back Breakage.	Dull sickle.	Replace.	7.8.4
	Worn sickle head pin.		7.8.3
	Bent or broken guard.	Straighten or replace.	7.8.7
	Incorrect end guards at sickle head.	Replace with correct number of special guards.	
Windrower Side Drift.	Header is dragging on one end and pulling to that side.	Adjust skid shoes to prevent cutterbar dragging.	6.17.8.4
		Adjust header flotation.	6.17.10
	Low tire pressure on one side (pull-type).	Check and correct tire pressure [30 psi (207 kPa)].	7.14.4
Lights Malfunctioning.	Improper ground.	Check for proper grounding between light base and header.	7.17
	Burned out bulb.	Replace bulb.	
	Poor connection.	Check connector at tractor/windrower.	6.4.3

SECTION 9 OPTIONS AND ATTACHMENTS

9 OPTIONS AND ATTACHMENTS

9.1 HYDRAULIC HEADER ANGLE KITS: PULL-TYPE



This kit allows the header angle to be adjusted hydraulically with a cylinder that replaces the standard mechanical link. A separate hydraulic circuit is required or the existing APT steering cylinder hydraulic circuit can be utilized, depending on the tractor hydraulics. Installation instructions are included with the kits.

9.2 ADDITIONAL SKID SHOES



In addition to standard two outer skid shoes, two inner skid shoes may be added for extra control of cutting height and protection of cutting components.

9.3 GAUGE ROLLER KIT

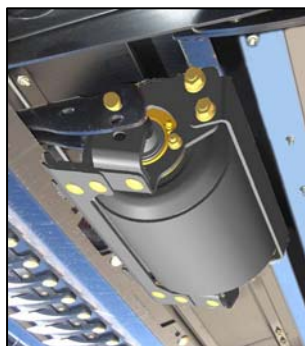

The gauge roller kit replaces the outer skid shoes, and consists of rollers in place of skid shoes. They can be adjusted for varying cutting height.

9.4 REPLACEMENT REEL BAT KITS: A30-S, A30-D

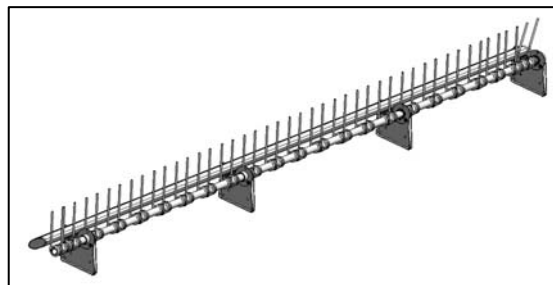

Consists of one complete bat assembly for ease of replacement.

9.5 STUB GUARD CONVERSION KIT

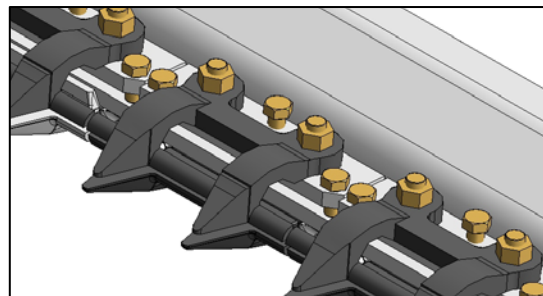

Stub guards, complete with top guides and adjuster plates are designed to cut tough crops.

Installation and adjustment instructions are included with the kit.

9.6 TALL CROP DIVIDER KIT

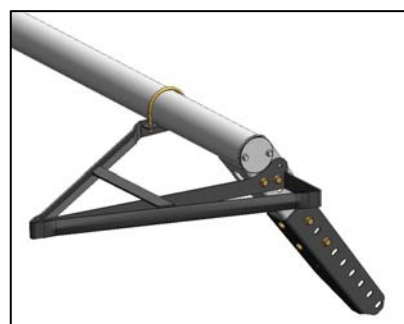

Tall crop dividers attach to the ends of the header for clean crop dividing and reel entry in tall crops. The kit includes left and right dividers, lean bar extensions and attachment hardware.

UNLOADING AND ASSEMBLY

10 UNLOADING AND ASSEMBLY

Header-specific instructional manual for unloading, assembly and set-up procedures are included with your shipment.

HEADER DESCRIPTION	USED ON	INSTRUCTION PART NUMBER
A30-S, A30-D	Pull-Type Mower Conditioner	MD Part # 169001
A30-S, A40-D	Self-Propelled Windrower	MD Part # 169078

INDEX

3 Point Hitch	26, 28	Forming Rods	93
Abbreviations	14	Forming Shields	88
APT	15, 17	Gauge Roller Kit	185
Assembly	186	Gauge Rollers	
Attachments	185	adjustment	80
Auger		removal/installation	175
beaters	92	Gearbox	
pan extensions	92	A30-D	165, 167
pans	157	A30-S	162, 163
position	66	A40-D	169, 170
rubber fingers	157	drain	159
speed	64	oil change	159
Auger Drive		Grass Seed Windrowing	92
A30-D belt tension	156	Greasing	104
A30-S belt tension	155	A30-D header	107, 108
A30-S, A30-D	153	A30-S header	105, 106
A40-D	158	A40-D header	109, 110
sprockets	64	hay conditioner	112
Auger Drive Chain		pull-type	113
A30-D	154	Ground Speed	91
A30-S	153	Guards	
Auger Speed		alignment	121
A30-S, A30-D	64	offset	123
A40-D	64	pointed	122, 123
Bearing, sealed		replacement	122
installation	116	stub	124, 125
Bolt Torques	98	Hay Conditioner	84
Break-In Inspection	176, 178	Haying Tips	95
Break-In Period	57	Header	
Clearance		cylinder lockouts	58
auger/stripper bar	66, 157	Header Angle	
sickle	126	adjustment	81
sickle head	142	Header Attachment	
Components	15	A30-S	33
Conditioner	159	A40-D	35
Couplers	46	self-propelled	33
Cutting Height	80	Header Detachment	
Decals		A30-S	46
roll gap	84	A40-D	47
safety	6	Header Flotation	82
Dimensions	19	Header Operation	63
Drawbar Adjustment	24	Hook-Up	
Drive Motor	161	3 point hitch	28
Drive Shields	103	drawbar	27
Driving on Windrow	95	electrical	29
Drying Agents	95	PTO & hydraulics	29
Electrical		Hook-Up, Pull-Type	27
lights and wiring	175	Hydraulic Connections	
Feed Pan Position	83	A30-S	33
Fluffer	89	A40-D	35
Fore-Aft Adjust		grass seed	47
A30-D auger	70	jumper hose	44
A30-S auger	66	M100, M105	35
A30-S, A30-D reel	75	M150, M155	38
A40 auger	74	M200	40
A40 reel	77	Hydraulic Fittings	99

INDEX

Hydraulics.....	117	tension	87
adding oil	117	timing	85
draining oil	117	unplugging	62
hoses and lines.....	118	Rubber Fingers.....	157
leaks	118	Safety	
oil filter	118	general	12
oil level.....	117	owner	23
relief valve.....	118	procedures.....	97
Jack	27	shut-down	58
Lean Bar.....	63	signal words.....	6
Lift Cylinder lockouts	58	signs.....	6
Lifting Vehicle.....	53	start-up.....	57
Lock-Outs	103	symbols.....	6
lift cylinder.....	58	Safety Signs	
steering.....	51	Pull-Type.....	7
Lubricants.....	101	self-propelled	10
Lubrication.....	104	Serial Number	1
Maintenance and Servicing.....	97	Shields, drive	103
Maintenance Record.....	177, 179	Shut-Down.....	58
Maintenance Schedule.....	176	Sickle	
Metric Conversions	102	bearing replacment.....	120
Moisture,topsoil	95	guards	121
Oiling	115	installation.....	120
Operating Variables	63	removal	119
Options	185	sections.....	119
Owner/Operator Responsibilities	23	spare.....	121
Pan	157	unplugging	62
Pitman Arm.....	141, 142	Sickle Drive	
PTO		timing	139
engaging.....	58	Sickle Drive Belt	
Raking	95	A30-D.....	130, 133
Reel		A30-S.....	128
A40-D.....	148	A40-D.....	135, 137
drive belts A30-S, A30-D.....	145	Sickle Drive Box	141
drive chain A30-S, A30-D	144	mounting bolts	141
position	75	oil level.....	115
reel tine to header pan clearance.....	80	pulley.....	143
tines and bearings A30-S, A30-D.....	146	Sickle Hold-Down	
tines and bearings A40-D.....	148	adjustments	126
Reel Bat Kit	185	Side Deflectors	88
Reel Drive		Skid Plates	
sprockets	65	additional	185
Reel Position		Skid Shoes	
A30-S, A30-D	75, 76	adustment.....	80
A40-D.....	77, 78	removal/installation	174
Reel Speed		wear plate replace	174
A30-S, A30-D	65	Specifications	19
A40-D.....	65	pull-type	19
Reel Tine to Header Pan Clearance	80	self-propelled	21
Relief Valve	118	Start-Up Check.....	57
Reservoir		Steering	59
hydraulic	117	Steering Cylinder	
oil level.....	117	adjust	59
Reverser Valve.....	44	during transport.....	53
Rock-Drop Position	83	Storage.....	96
Rolls		Stripper Bars	66, 157
alignment.....	85	extensions.....	158
gap.....	84	Stub Guard Conversion Kit.....	185

INDEX

Stub Guards	92	windrower performance	180
double knife	125	Turning	
single knife	124	180 degrees	61
Tall Crop Dividers	185	square corners	60
adjustment	90	Unhook Pull-Type	30
removal	90	Unloading	55, 186
Tedding	95	Unplugging	
Tine Adjustment	79	rolls	62
Tire Inflation	173	sickle	62
Topography	95	Valve Blocks	47
Torques	98	Vertical Adjust	
Towing	49	A30-D auger	72
Tracking, Pull-Type	59	A30-S auger	68
Tractor		A30-S, A30-D reel	76
drawbar	24	A40 auger	74
setup	24	A40 reel	78
Transport Lock	51, 53	Wear Plates	174
Transporting	49, 50	Weather	95
flatbed	52	Wheels	
Troubleshooting		remove/install	172
mechanical	183	Windrow Characteristics	95

NOTES

MacDon Industries Ltd.

680 Moray Street
Winnipeg, Manitoba
Canada R3J 3S3
t. (204) 885-5590
f. (204) 832-7749

MacDon, Inc.

10708 N. Pomona Avenue
Kansas City, Missouri
United States 64153-1924
t. (816) 891-7313
f. (816) 891-7323

MacDon Australia Pty. Ltd.

A.C.N. 079 393 721
P.O. Box 243, Suite 3, 143 Main Street
Greensborough, Victoria, Australia 3088
t. 03 9432 9982
f. 03 9432 9972

LLC MacDon Russia Ltd.

123317 Moscow, Russia
10 Presnenskaya nab, Block C
Floor 5, Office No. 534, Regus Business Centre
t. +7 495 775 6971
f. +7 495 967 7600

CUSTOMERS
www.macdon.com

DEALERS
www.macdondealers.com

Trademarks of products are the marks of their
respective manufacturers and/or distributors.

Printed in Canada