

9352c SELF-PROPELLED WINDROWER

OPERATOR'S MANUAL

CALIFORNIA

Proposition 65 Warning

Diesel engine exhaust and some of its constituents are known to the State of California to cause cancer, birth defects, and other reproductive harm.

INTRODUCTION

Your new Self-Propelled Windrower is designed to cut and lay in windrows, a wide variety of grain, hay and specialty crops. Windrowing allows starting the harvest earlier, protects the crop from wind damage, and gives you more flexibility in scheduling combine time.

The power unit (referred to in this manual as the "tractor"), when coupled with one of the specially designed draper or auger headers, provides a package which incorporates many features and improvements in design requested by Owner/Operators like yourself.

NOTE: This manual contains information on the windrower tractor only. It is to be used in conjunction with the Header Operator's Manual.

CAREFULLY READ BOTH MANUALS TO BECOME FAMILIAR WITH ALL RECOMMENDED PROCEDURES BEFORE ATTEMPTING TO UNLOAD, ASSEMBLE OR USE THE WINDROWER.

Use the manual as your first source of information about the machine. If you follow the instructions given in this manual, your Windrower will work well for many years.

The manual contains instructions for "Safety", "Operation", and "Maintenance/Service". In addition "Unloading and Assembly" information is given towards the back of this book.

Use the Table of Contents and the Index to guide you to specific areas. Study the Table of Contents to familiarize yourself with how the material is organized.

Keep this manual handy for frequent reference and to pass on to new operators or owners. Call your Windrower dealer if you need assistance, information, or additional copies of the manuals.

NOTE: Right hand (R/H) and left hand (L/H) designations are determined from the operator's position, facing forward.



TABLE OF CONTENTS

	PAGE
INTRODUCTION	1
SERIAL NUMBER LOCATIONS	5
SAFETY	
Safety Alert Symbol	6
Signal Words	6
Safety Signs	7,8
General Farm Safety	9,10
SPECIFICATIONS	
Tractor	11
Engines.....	13
Hardware Torque Specifications	13
Hydraulic Fitting Torque Specifications	14
OPERATOR'S STATION	
Symbol Definitions.....	15, 16
Mac Monitor	17, 18
Operator Presence System	19
Gauges	19
Speedometer	19
Ignition Switch	20
Glow Plug Switch.....	20
Lights	20
Cab Temperature Controls	21
Windshield Wiper Control	21
Windrower Controls	22
Header Controls	23 - 25
Seat Belts	25
Seat Adjustments	26
Operator Amenities.....	27
OPERATION	
Your Responsibilities as an Owner/Operator	28
To the New Operator	28
Break-In Period.....	29
Pre-Starting Checks: Annual	30
Pre-Starting Checks: Daily	31
Start-Up Procedure.....	32, 33
Driving the Windrower	
Safety.....	34
To Drive Forward	35
To Drive Rearward.....	36
Making a Spin Turn.....	37
Stopping Procedure	
To Stop Windrower	38
To Stop Engine	38
Leaving the Windrower	39
Emergency Exit.....	39
Attaching the Header	40 - 42
Adding Rear Weight	43, 44
Detaching the Header.....	45, 46
Operating the Header	47
Header Lift Cylinder Stops.....	47
Header Angle.....	48
Header Levelling.....	49
Header Flotation	50
Transporting the Windrower	
Driving on Roads	51

TABLE OF CONTENTS

OPERATION	PAGE
Transporting the Windrower (continued)	
Towing With a Trailer	52, 53
Towing without a Trailer	54, 55
Storage Procedure	56
MAINTENANCE/SERVICE	
Service Procedures	57
Seat Belt Inspection and Maintenance	58
Operator Presence System	58
R/H Step Ladder Use & Storage	58
Fuels, Fluids and Lubricants	
Diesel Fuel	59
Engine Coolant	59
Grease	59
Hydraulic Oil.....	59
Engine Oil	60
Bevel Gear Box Lubricant.....	60
Power Hub Gear Lubricant	60
Storing Lubricants.....	60
System Capacities	60
Greasing the Windrower Tractor	61 - 63
Diesel Engine	
Opening and Closing Hood.....	64
Lubricating Oil.....	65
Belts	66, 67
Valve Tappet Clearance	67
General Engine Inspection.....	67
Diesel Engine Air Intake System: Air Cleaner	68, 69
Diesel Engine Fuel System	
Storing Fuel.....	70
Refuelling Windrower.....	70
Fuel Tank Venting.....	70
Water & Sediment Separator	71
Fuel Filter	72
Feed Pump Strainer.....	72
Fuel System Air Removal	73, 74
Engine Exhaust System: Muffler	75
Engine Cooling System	
Coolant Level	76
Radiator Cap.....	76
Anti-Freeze Concentration.....	76
Changing Coolant	77
Screens and Coolers	78
Electrical System	
Battery.....	79 - 81
Preventing Alternator and Regulator Damage.....	82
Lights and Bulbs	83 - 86
Circuit Breakers	87
Electrical Schematics.....	back of book
Hydraulic System	
Safety.....	88
Hydraulic Oil Cooler	88
Hydraulic Oil & Filters	88, 89

TABLE OF CONTENTS

	PAGE
MAINTENANCE/SERVICE (continued)	
Hydraulic System: Header & Reel Lift	
Cylinder Control Valve Relief Pressure	90
Header & Reel Lift Hydraulic Schematic.....	back of book
Header Drive: Hydraulics	
Flow Control Block.....	91
Header Drive Relief Pressure	91
Header Drive Hydraulic Schematic.....	back of book
Header Drive	
Bevel Gear Box Lubricant.....	92
Header Drive Belt.....	92
Header Drive Belt Pulley Alignment.....	93, 94
Header Drive Belt Guides & Pulley Shield.....	94, 95
Traction Drive: Hydraulics	
Transmission Oil Pressure.....	96
Charge Pump Pressure	96
Traction Drive Hydraulic Schematic.....	back of book
Traction Drive: Neutral Lock and Steering	
Checks	97 - 99
Troubleshooting	100
Neutral Set-Up Procedure.....	101, 102
Traction Drive:	
Ground Speed Lever Friction Device.....	103
Wheels and Tires	104 - 106
Cab Air System.....	107 - 109
MAINTENANCE SCHEDULE	110, 111
MAINTENANCE RECORD	112, 113
TROUBLE SHOOTING	
Cab Air System.....	114 - 117
Engine	117 - 122
Electrical.....	122, 123
Traction Drive System	123 - 125
Steering and Ground Speed Controls	125
Header Hydraulics	126
Header Drive	127 - 128
Operator's Seat.....	128
OPTIONS AND ATTACHMENTS	129
UNLOADING.....	130, 131
ASSEMBLY	
Tires.....	132, 133
Battery	134, 135
Adjustments & Checks	135
Preparing for Harvest Headers.....	136 - 139
Radio & Two-Way Radio Installation	140, 141
Tool Box	141
Swath Roller Installation	142
INDEX	143 - 145
ELECTRICAL & HYDRAULIC SCHEMATICS	146

SERIAL NUMBER LOCATIONS

Record the serial numbers in the space provided.

Tractor: _____

Plate is located on left side of main frame,
near rear corner.



TRACTOR SERIAL PLATE LOCATION

Diesel Engine: _____

Plate is located on right side of block,
beside injection pump.

NOTE: When ordering parts and service, be sure
to give your dealer the complete and
proper serial number. For engine parts,
see your local Cummins engine dealer.

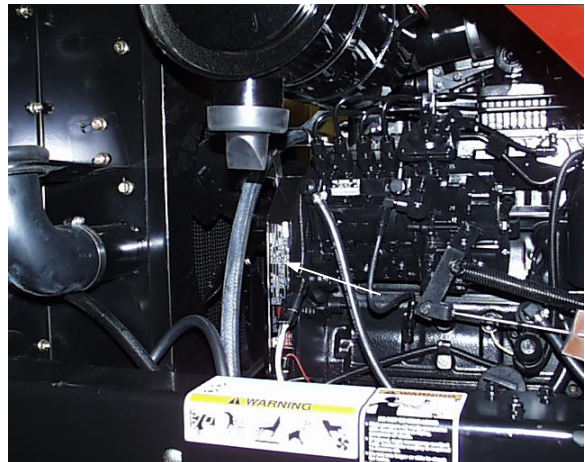

DIESEL ENGINE SERIAL PLATE LOCATION

SAFETY

SAFETY ALERT SYMBOL



This safety alert symbol indicates important safety messages in this manual and on safety signs on the header.

This symbol means:
ATTENTION !
BECOME ALERT !
YOUR SAFETY IS INVOLVED !

Carefully read and follow the safety message accompanying this symbol.

Why is SAFETY important to you?

- 3 BIG REASONS
- ACCIDENTS DISABLE AND KILL
 - ACCIDENTS COST
 - ACCIDENTS CAN BE AVOIDED

SIGNAL WORDS

Note the use of the signal words DANGER, WARNING, and CAUTION with safety messages. The appropriate signal word for each message has been selected using the following guidelines:



DANGER – Indicates an imminently hazardous situation that, if not avoided, will result in death or serious injury.



WARNING – Indicates a potentially hazardous situation that, if not avoided, could result in death or serious injury. It is also used to alert against unsafe practices.



CAUTION – Indicates a potentially hazardous situation that, if not avoided, may result in minor or moderate injury. It is also used as a reminder of good safety practices.

SAFETY

SAFETY SIGNS

- The safety signs reproduced below appear on the windrower at the locations listed.
- Keep safety signs clear and legible at all times.
- Replace safety signs that are missing or become illegible.
- If original parts on which a safety sign was installed are replaced, be sure the repair part also bears the current safety sign.
- Safety signs are available from your Dealer Parts Department. The part number is printed in the lower R/H corner of each safety sign.

To install safety signs:

1. Be sure the installation area is clean and dry.
2. Decide on the exact position before you remove the backing paper.
3. Remove the smaller portion of the split backing paper.
4. Place the sign in position and slowly peel back the remaining paper, smoothing the sign as it is applied.
5. Small air pockets can be smoothed out or pricked with a pin.

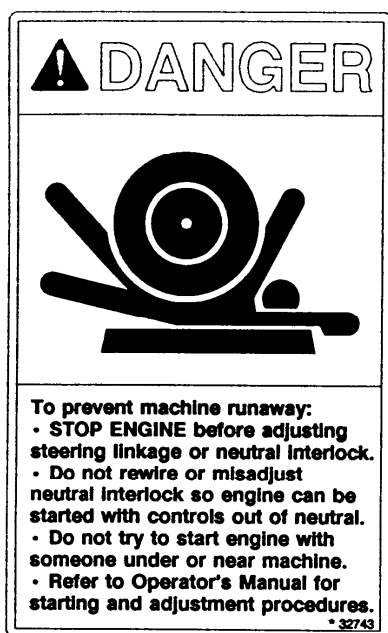

P/N 32743 - CENTER FRAME CROSS CHANNEL (BOTH SIDES)

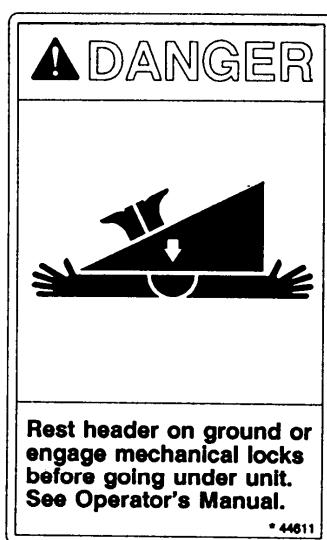

P/N 44611 - LIFT LEGS

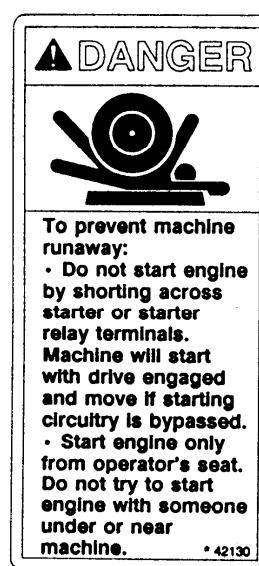

P/N 42130 - FRONT LEFT ENGINE SUPPORT



P/N 30316 - DRIVELINE

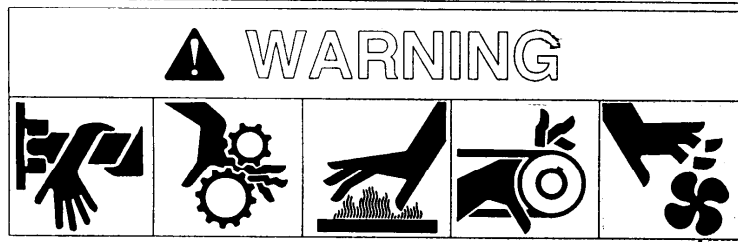
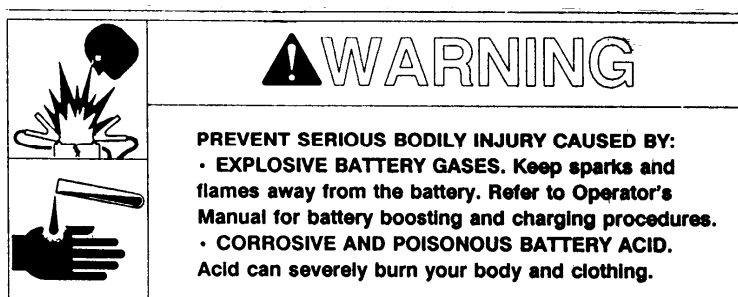

P/N 45935 - ENGINE COMPARTMENT, LEFT REAR

SAFETY

SAFETY SIGNS (continued)



P/N 45420 - ENGINE COMPARTMENT, RIGHT REAR

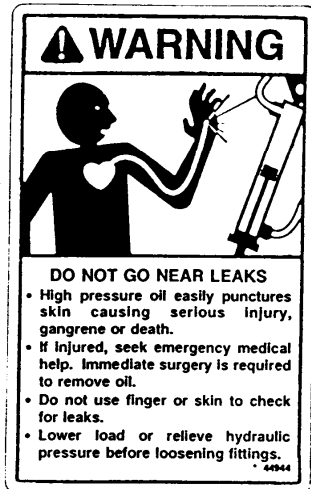

P/N 44944 - ENGINE COMPARTMENT, LEFT AND RIGHT



P/N 32738 - HEADER DRIVE PULLEY SHIELD

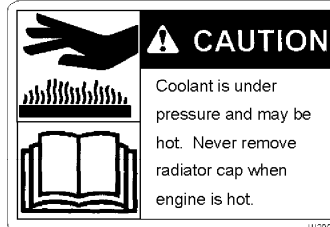

P/N 111200 - ENGINE COMPARTMENT, LEFT SIDE

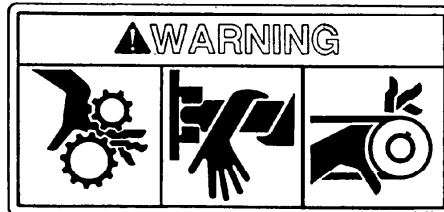

P/N 42251 - REAR FRAME CROSS CHANNEL

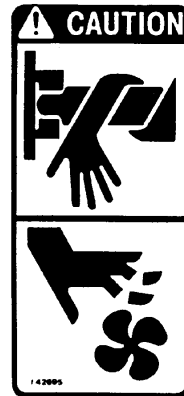

P/N 42695 - DRIVELINE FAN SHIELD

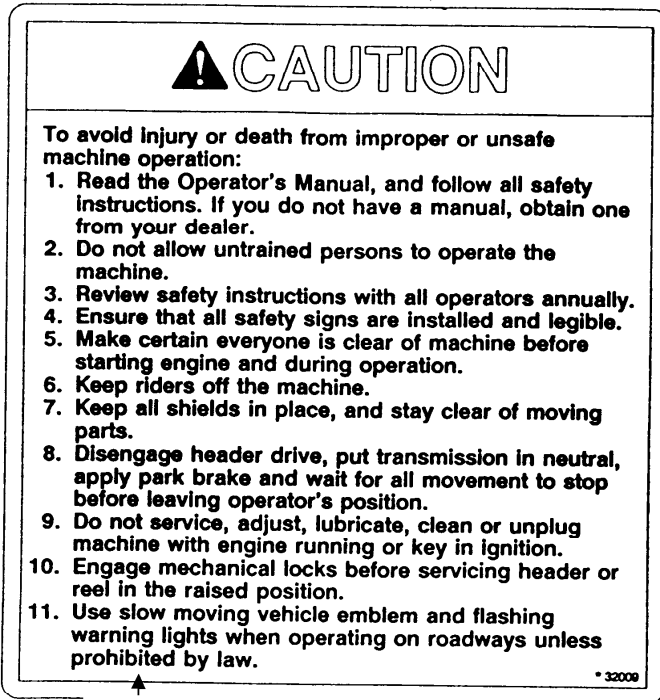

P/N 32009 - CAB DOOR, SIDE PANEL - P/N 109208

Stability of machine varies with different attachments, tractor options, terrain and operator's driving technique. Install weights at rear of tractor to provide adequate machine stability. Refer to operator's manual for weight recommended for specific tractor applications.

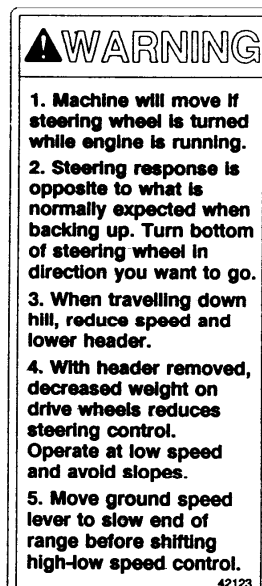

P/N 42123 - LEFT CAB CENTER POST - P/N 109200



P/N 32744 - CAB DOOR & LEFT CENTER POST

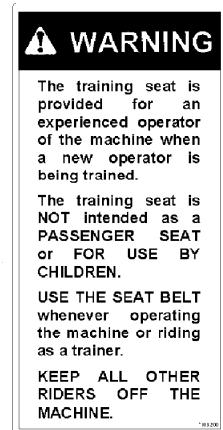

SAFETY

GENERAL SAFETY



The following are general farm safety precautions that should be part of your operating procedure for all types of machinery.

1. Protect yourself.

When assembling, operating and servicing machinery, wear all the protective clothing and personal safety devices that **COULD** be necessary for the job at hand. Don't take chances.

You may need:

- a hard hat.
- protective shoes with slip resistant soles.
- protective glasses or goggles.
- heavy gloves.
- wet weather gear.
- respirator or filter mask.
- hearing protection. Be aware that prolonged exposure to loud noise can cause impairment or loss of hearing. Wearing a suitable hearing protective device such as ear muffs (A) or ear plugs (B) protects against objectionable or loud noises.

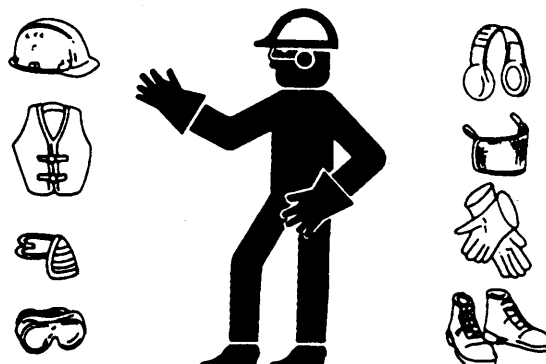

PROTECT YOURSELF



PROTECT AGAINST NOISE

2. Provide a first-aid kit for use in case of emergencies.

3. Keep a fire extinguisher on the machine. Be sure the extinguisher is properly maintained and be familiar with its proper use.

4. Keep young children away from machinery at all times.

5. Be aware that accidents often happen when the operator is tired or in a hurry to get finished. Take the time to consider the safest way. Never ignore warning signs of fatigue.



BE PREPARED FOR EMERGENCIES

SAFETY



GENERAL SAFETY (continued)

6. Wear close-fitting clothing and cover long hair. Never wear dangling items such as scarves or bracelets.
7. Keep hands, feet, clothing and hair away from moving parts. Never attempt to clear obstructions or objects from a machine while the engine is running.
8. Keep all shields in place. Never alter or remove safety equipment. Make sure driveline guards can rotate independently of the shaft and can telescope freely.
9. Use only service and repair parts made or approved by the equipment manufacturer. Substituted parts may not meet strength, design, or safety requirements.
10. Do not modify the machine. Unauthorized modifications may impair the function and/or safety and affect machine life.
11. Stop engine and remove key from ignition before leaving operator's seat for any reason. A child or even a pet could engage an idling machine.
12. Keep the area used for servicing machinery clean and dry. Wet or oily floors are slippery. Wet spots can be dangerous when working with electrical equipment. Be sure all electrical outlets and tools are properly grounded.
13. Use adequate light for the job at hand.
14. Keep machinery clean. Straw and chaff on a hot engine are a fire hazard. Do not allow oil or grease to accumulate on service platforms, ladders or controls. Clean machines before storage.
15. Never use gasoline, naphtha or any volatile material for cleaning purposes. These materials may be toxic and/or flammable.
16. When storing machinery, cover sharp or extending components to prevent injury from accidental contact.



NEVER WEAR LOOSE OR DANGLING CLOTHES

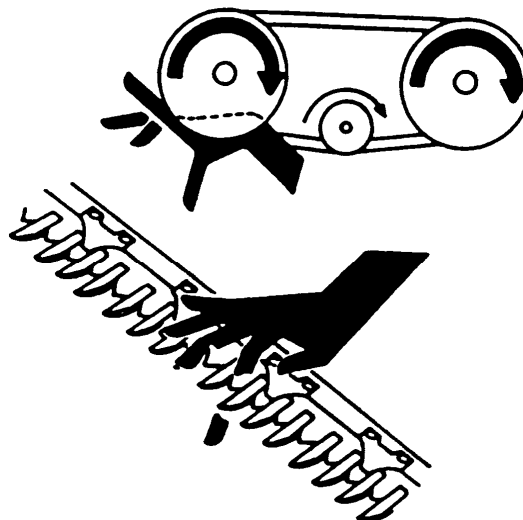

KEEP AWAY FROM MOVING PARTS



KEEP SERVICE AREA CLEAN AND DRY

SPECIFICATIONS

TRACTOR DIMENSIONS:

Weight (varies with tire size):

e.g. With 16.5L-16.1 forked casters & 500-70R24 radial bar tread drive tires.....8516 lbs. (3863 kg)

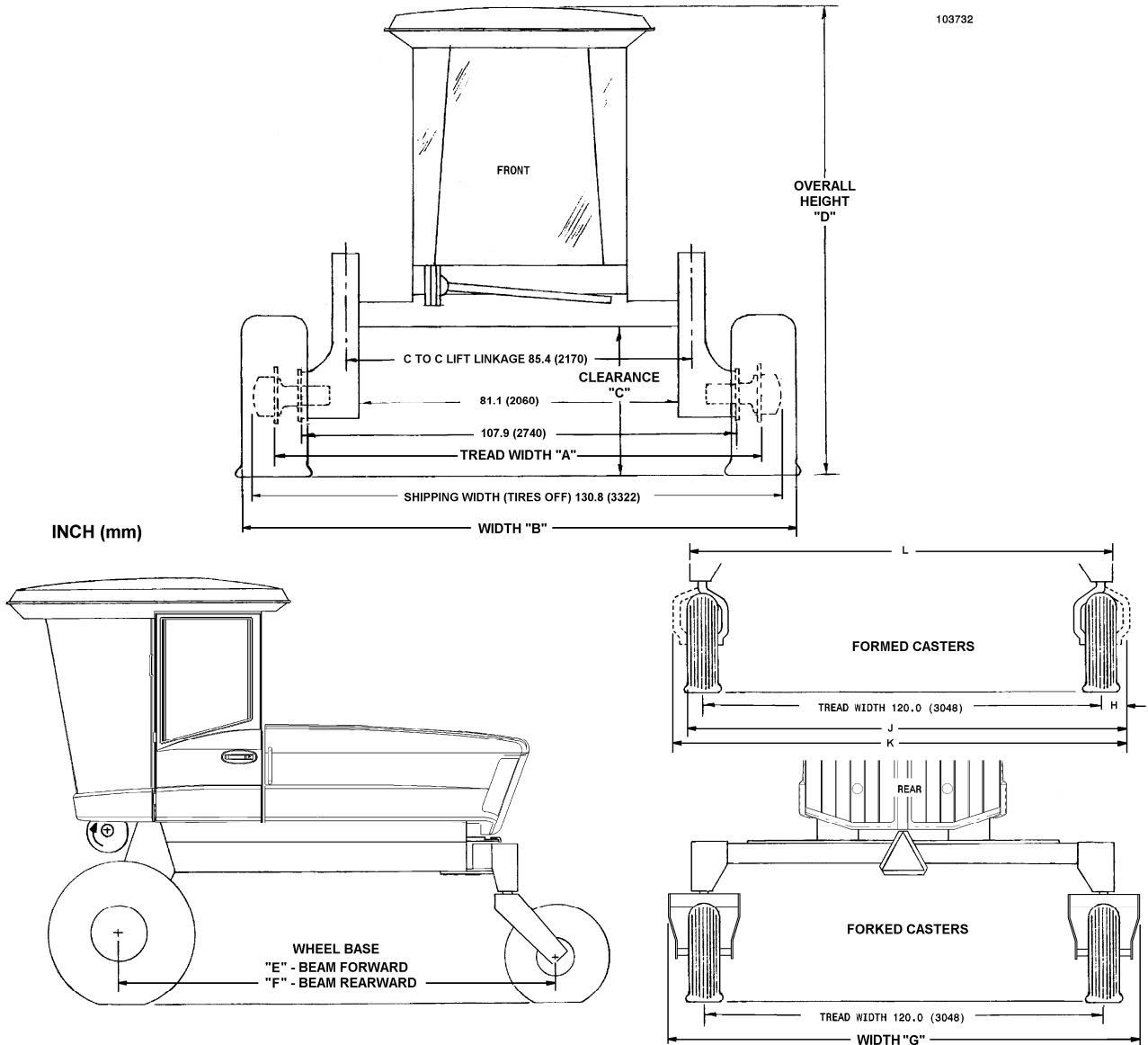

Drive Tire	500-70R24	540 - 65R24	560 - 65D24
Tread Width A	117" (2972 mm)	117" (2972 mm)	117" (2972 mm)
Front Width B	136" (3455 mm)	137" (3480 mm)	139.3" (3538 mm)
Clearance C	43.4" (1102 mm)	42.1" (1070 mm)	43.0" (1092 mm)
Height D	127.6" (3240 mm)	126.3" (3210 mm)	127.2" (3230 mm)

Drive Tire	14.9 - 24, 500 - 70R24, 540 - 65R24, OR 560 - 65D24		
Caster Tire	11.0 - 16 Forked	16.5L - 16.1 Forked	7.5L - 16 Formed
Wheel Base E	118.3" (3005 mm)	118.3" (3005 mm)	114.4" (2906 mm)
Wheel Base F	133.3" (3385 mm)	133.3" (3385 mm)	129.4" (3287 mm)
Rear Width G	142.3" (3615 mm)	142.3" (3615 mm)	-
Dim. H (Formed)	-	-	-
Rear Width J	-	-	-
Rear Width K	-	-	143" (3632 mm)
Rear Width L	-	-	130.1" (3304 mm)

SPECIFICATIONS

TRANSMISSION:

Type Hydrostatic
 Displacement..... 3.0 cu.in. (49.16 cc)
 Fluid..... See "Fuels, Fluids and Lubricants" in Maintenance/Service section

FINAL DRIVE:

Type Planetary Gear Drive
 Ratio: 37.68 to 1
 Lubricant..... See "Fuels, Fluids and Lubricants" in Maintenance/Service section

SPEED RANGE:

Dual Speed Forward.: Field: 0 - 9 mph (14.5 km/h) Road: 0 – 15.5 mph (25 km/h)
 Reverse 0 - 6 mph (10 km/h)

HEADER DRIVE:

Mechanical 4-A section belt, electric over hydraulic clutch
 Hydraulic 2 circuits, clutch activated, w/ independent flow controls (3 - 9 US gpm each)

CYLINDER CONTROL VALVE: Type Cartridge valves in manifold block

ELECTRICAL:

Battery Requirement 12 Volt, minimum 640 CCA @ 0°F (-18°C)
 Alternator 110 Amp

Breakers:

Lights (manual re-set)..... 50 Amp
 Main (all functions except lights, manual re-set) 50 Amp
 Air Conditioning and Seat Suspension Switch 25 Amp
 Header Controls, Operator Presence System 10 Amp
 Instruments, Radio and Screen Motors 6 Amp
 Wiper, Interior Light, Radio Memory and Auxiliary Power Points 6 Amp

Fuse: Cigar Lighter 20 Amp

AIR CONDITIONING:

Cooling Capacity 24,000 B.T.U./hour
 Compressor..... 9.5 cu. in./rev., rotary

BRAKES: Hydraulic, integral disc brakes – engaged when transmission locked in neutral

DRIVE TIRES:

14.9 – 24 R4 Bar Tread – Sprayer Application Only
 560 – 65D24 Softrac II Turf Tread
 500 – 70R24 Radial - Bar Tread
 540 – 65R24 Radial – Deep Bar Tread

NOTE: Pressures below are for a fully loaded header. If hay conditioner is removed, or a bat reel replaces a pick-up reel, reduce pressures by 2 psi (14 kPa).

Drive Tire Inflation Pressures				
Header Model	Header Size	14.9 - 24	500 - 70R24	540- 65R24 or 560-65D24
912, 922, 933	All	33 psi (228 kPa)	19 psi (132kPa)	18 psi (125 kPa)
962	All	36 psi (248 kPa)	21 psi (145 kPa)	20 psi (138 kPa)
972	12 - 21	33 psi (228 kPa)	19 psi (132kPa)	18 psi (125 kPa)
972/Sprayer	25 - 36	42 psi (289 kPa)	24 psi (165 kPa)	22 psi (151 kPa)

TAIL WHEEL TIRES: Inflation Pressure

16.5L - 16.1 I 1 8 ply Rib Implement .. 10 psi (70 kPa)
 11 – 16 F-2M 8 Ply Rib Implement..... 10 psi (70 kPa)
 7.5 – 16 6 ply Single Rib TT, F-1..... 19 psi (132 kPa)

CAPACITIES: See "System Capacities" in Maintenance/Service section.

TORQUE SPECIFICATIONS

TIGHTENING HYDRAULIC O-RING FITTINGS*

1. Inspect O-ring and seat for dirt or obvious defects.
2. On angle fittings, back the lock nut off until washer bottoms out at top of groove.
3. Hand tighten fitting until back-up washer or washer face (if straight fitting) bottoms on face and O-ring is seated.
4. Position angle fittings by unscrewing no more than one turn.
5. Tighten straight fittings to torque shown.
6. Tighten angle fittings to torque shown while holding body of fitting with a wrench.

* The torque values shown are based on lubricated connections as in reassembly.

Thread Size (in.)	Nut Size Across Flats (in.)	Torque Value*		Recommended Turns to Tighten (after finger tightening)	
		N·m	[lb-ft]	Flats	Turns
3/8	1/2	8	[6]	2	1/3
7/16	9/16	12	[9]	2	1/3
1/2	5/8	16	[12]	2	1/3
9/16	11/16	24	[18]	2	1/3
3/4	7/8	46	[34]	2	1/3
7/8	1	62	[46]	1-1/2	1/4
1-1/16	1-1/4	102	[75]	1	1/6
1-3/16	1-3/8	122	[90]	1	1/6
1-5/16	1-1/2	142	[105]	3/4	1/8
1-5/8	1-7/8	190	[140]	3/4	1/8
1-7/8	2-1/8	217	[160]	1/2	1/12

TIGHTENING HYDRAULIC FLARE-TYPE TUBE FITTINGS*

1. Check flare and flare seat for defects that might cause leakage.
2. Align tube with fitting before tightening.
3. Lubricate connection and hand tighten swivel nut until snug.
4. To prevent twisting the tube(s), use two wrenches. Place one wrench on the connector body and with the second tighten the swivel nut to the torque shown.

























* The torque values shown are based on lubricated connections as in reassembly.

Tube Size O.D. (in.)	Nut Size Across Flats (in.)	Torque Value*		Recommended Turns to Tighten (after finger tightening)	
		N·m	[lb-ft]	Flats	Turns
3/16	7/16	8	[6]	1	1/6
1/4	9/16	12	[9]	1	1/6
5/16	5/8	16	[12]	1	1/6
3/8	11/16	24	[18]	1	1/6
1/2	7/8	46	[34]	1	1/6
5/8	1	62	[46]	1	1/6
3/4	1-1/4	102	[75]	3/4	1/8
7/8	1-3/8	122	[90]	3/4	1/8

OPERATOR'S STATION











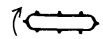









Symbol Definitions

The following symbols are used to depict functions or reactions at the various instruments and controls. Learn the meaning of these symbols before operating the Windrower.

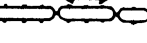
	- Engine oil pressure		- Turn signals
	- Transmission oil pressure		- Temperature control: heater
	- Parking brake on – NOT USED with this model.		- Temperature control: Air conditioning
	- Engine hours		- Turn to increase output: Heater or air conditioner
	- Header hours		- Blower
	- Engine R.P.M.		- Windshield wiper
	- Area cut per hour		- Engine throttle
	- Area cut: subtotal Area cut: grand total		- Forward ground speed
	- Fuel		- Reverse ground speed
	- Voltage		- Fast
	- Engine coolant temperature		- Slow
	- Flashing amber lights		- Neutral
	- Head lights		- Reel speed
	- Work (field) lights		

OPERATOR'S STATION

Symbol Definitions (continued)

	- Conveyor speed		- Header tilt up	
	- Engaged		- Disengaged	
	- Header drive			- Header tilt down
	- Header height		- Reel forward	
	- Increase		- Reel aft	
	- Decrease		- Seatback angle	
	- Reel height		- Seat fore-aft	
	- Deck shift		- Seat height	
	- Speed range control		- Seat fore-aft isolator lockout	
High	Low		- Cigarette lighter	
	- On	- Header express down option		
	- Bypass			

OPERATOR'S STATION



CAUTION: Learn and practice safe use of controls before operating.

IMPORTANT: See your Dealer if there are any instrument malfunctions. Operate windrower only if all instruments work properly.

Mac-Monitor

The LCD display allows the operator to monitor various machine systems, while the warning lights and audible tones are provided to alert the operator that continued operation will cause serious machine damage.

Six Function LCD displays the following:

- tachometer (engine speed) (B)
- cutting rate (area per hour) (C)
- subtotal area (D)
- grand total area (D)
- engine accumulated hours (E)
- header accumulated hours (F)

Select function by momentarily pressing switch (A) once for each mode change. The function light for the current selection will flash for 10 seconds. The other function lights burn steadily during scrolling to indicate which functions are currently available at the present engine speed.

When engine is not running, and key is in the ON position, subtotal area is the default and momentarily pressing switch (A) scrolls through grand total area, engine hours, header hours and back to subtotal area.

When engine is running at less than 2000 rpm, tachometer is the default and momentarily pressing switch (A) scrolls through all six functions. After 10 seconds in any mode, the monitor switches back to tachometer.

When engine speed is greater than 2000 rpm, tachometer is the default and momentarily pressing switch (A) scrolls through cutting rate, subtotal area and back to tachometer. Tach or cutting rate will remain displayed until switch is pressed, while subtotal area will revert back to tachometer after 10 seconds

TACHOMETER (B):

Indicates engine speed in revolutions per minute.

CUTTING RATE (Area per hour) (C):

Displays in either acres or hectares. Calculates rate of crop cut when header is engaged and engine rpm exceeds 2000 rpm based on ground speed and programmed cut width.

SUBTOTAL/GRAND TOTAL CUT AREA (D):

Displays in either acres or hectares. Subtotal cut area will display first. This shows area cut since last reset. When in this mode hold the button for 5 seconds to reset the subtotal to zero.

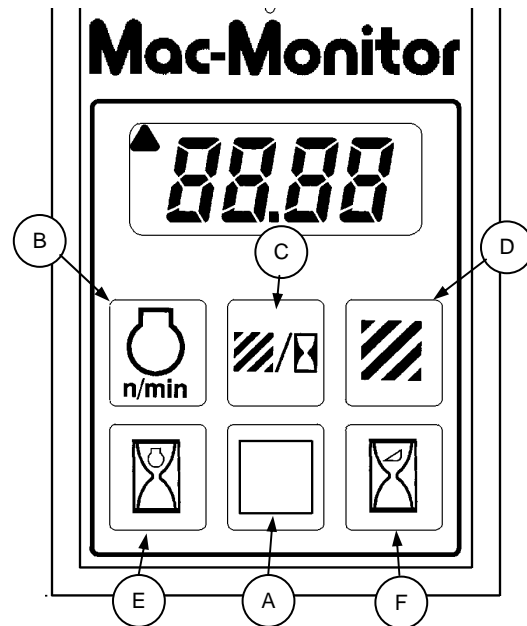

Grand total cut area shows total area cut over life of the windrower. After 9999, display will flash back and forth between thousand units and hundred units. For example, 53286 would be displayed by flashing between 53_ and _286, while 573902 would be displayed by flashing between 573_ and _902.

ENGINE HOUR METER (E):

Accumulates time that the engine is running. The display will alternate between 4 digits (representing hours accumulated) and tenths of an hour.

HEADER HOUR METER (F):

Accumulates time that the header is engaged with the engine running. The display will alternate between 4 digits (representing hours accumulated) and tenths of an hour.

PROGRAMMING

To ensure cutting rate, cut area and speedometer display correctly, program the monitor for units of measure, cut width and tire size as follows:

1. Turn the ignition key to the off position
2. Depress and hold switch (A) while turning the key to the on position to enter programming mode, then release switch.

NOTE: Programming mode works only if engine is not running.

3. Momentarily press switch (A) to scroll through these programming modes: "ENG/SI", "CUT WIDTH" and "TIRE SIZE". Do not hold switch for more than 5 seconds. The active selection within each mode flashes on the display.

Continued next page.

OPERATOR'S STATION

Mac-Monitor: PROGRAMMING (continued)

- Once the desired programming mode is displayed, enter the selection mode by pressing and holding switch (A) for more than 5 seconds. (At 5 seconds there will be an audible tone. Release switch at tone.)
- In the "ENG/SI" selection mode the monitor shows "ENG" or "SI", whichever unit of measure is active. To scroll between the two, momentarily push switch (A). "SI" will cause cutting rate and cut area totals to display in hectares. As well, the speedometer will display in kilometers per hour. When in "SI", the small triangle at the top left corner of the digital display will be illuminated. "ENG" will cause cutting rate and cut area totals to display in acres and the speedometer to display in miles per hour. Shipping Position = ENG.
- To select either "ENG" or "SI" once it is displayed, press and hold switch (A) for more than 5 seconds. (At 5 seconds there will be an audible tone. Release switch at tone.) This also advances the monitor to the next programming mode (CUT WIDTH).
- Press switch (A) for 5 seconds again to enter the "CUT WIDTH" selection mode. The monitor shows the active cut width. To scroll through the cut widths, momentarily press switch (A) to scroll in 0.5 foot increasing increments through a cutting range of 10.0 to 37.0 feet (3.05 to 11.28 meters). Display in feet will have an "F" following the width, e.g. 24.5 feet cutting width would be shown as "24.5F". Shipping Position = 10.0F
NOTE: To advance the cut width in increments of 5 feet instead of 0.5, turn the header drive switch on and off again (see page 23).
- To select a cut width once it is displayed, press and hold switch (A) for more than 5 seconds. (At 5 seconds there will be an audible tone. Release switch at tone.) This also advances the monitor to the next programming mode (TIRE SIZE).
- Press switch (A) for 5 seconds again to enter the "TIRE SIZE" selection mode. The monitor shows the active tire size. Momentarily press switch (A) to scroll through tire options. This selection will trigger the correct readout for speedometer, based on rolling diameter of each tire size. Shipping Position = 21.5. **NOTE:** For units with 500 series tires, select the "500" option.
- To select a tire size once it is displayed, press and hold switch (A) for more than 5 seconds. (At 5 seconds there will be an audible tone. Release switch at tone.) This also returns the monitor to the "ENG/SI" programming mode.
- To save the settings into memory and return the monitor into the normal working mode, turn the key to the "off" position and back on again. This can be done from any of the three main programming modes (ENG/SI, CUT WIDTH, TIRE SIZE), but not from the selection mode within any of these.

Mac-Monitor Machine Warning System:

Consists of individual lights to indicate low engine oil pressure, low transmission oil pressure (and park brake) on. An audible tone will sound whenever one of the indicator lights is on. In addition, the tone will sound when a high engine coolant temperature is indicated.

ENGINE OIL PRESSURE LIGHT (G):

Both light and tone will be activated when ignition switch is turned ON if engine oil pressure is below 14 psi (98 kPa). If light and tone stay on for more than a few seconds after engine starts, or if they activate while engine is running, shut engine off and check engine oil level.

TRANSMISSION OIL PRESSURE LIGHT (H):

Both light and tone will be activated when ignition switch is turned ON if transmission oil pressure is below 150 psi (1035 kPa). Do not drive the windrower until light and tone go off. If light and tone stay on after engine starts, or if they activate during operation, shut engine off and check hydraulic oil level at reservoir. If oil level is adequate, measure supercharge relief pressure. See "Traction Drive: Hydraulics" in Maintenance/Service section.

PARKING BRAKE LIGHT (J):

This windrower is equipped with hydraulically activated disc brakes that are automatically engaged when the ground speed lever and steering wheel are locked in Neutral. Park brake light will illuminate when brake is engaged. Brakes disengage when lever and wheel are moved out of neutral.

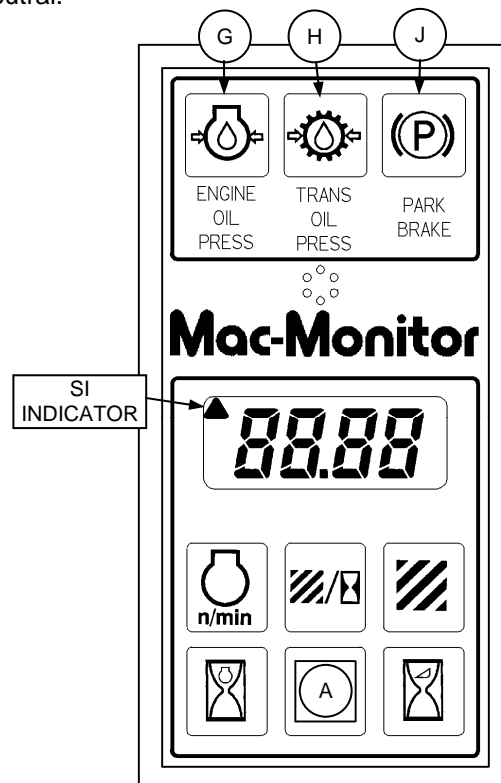

OPERATOR'S STATION

Operator Presence System

Requires the operator to be seated in the seat in order to engage the header drive. Should the operator leave the seat with the header drive engaged, power is maintained to the header drive for 5 seconds, after which the header is shut off.

NOTE: If the operator leaves the seat for more than 5 seconds and then sits down again, *the operator must move the header engage switch to "OFF" position and back to the "ON" position again to restart the header.*

Gauges

FUEL GAUGE (A) - Indicates fuel level in tank. Check fuel gauge before beginning day's operation. Stop to refuel before fuel gauge reaches empty mark. Use fuel specified under "Fuels, Fluids and Lubricants" in Maintenance/ Service section.

Should engine run out of fuel and not start in several tries, air must be bled from the fuel system. See "Fuel System Air Removal" in Maintenance /Service section.

VOLT METER (B) - Indicates condition of battery and alternator. With key switch in the ON position and the engine NOT running, a reading of 12 indicates fully charged battery. Watch for changes in the volt reading:

Reading (engine running)	Indicated Condition
14	normal
over 16	regulator misadjusted
under 12	alternator not working or regulator misadjusted

ENGINE TEMPERATURE GAUGE (C) - Monitors the temperature of engine coolant. With engine running, temperature gauge should read in the 180° - 220°F operating range (82° - 105°C).

Allow engine temperature to rise to this range before beginning operation. If gauge reaches approximately 220°F (105°C) a warning tone will sound. Stop engine immediately and determine cause. (See Trouble Shooting section.)

NOTE: If a tone sounds when engine temperature is below 220°F (105°C) and no indicator light illuminates [(G), (H) or (J) on Mac-Monitor, page 18], check bulbs.

Speedometer

The speedometer (D) indicates vehicle speed in miles per hour or kilometres per hour. Programming to switch between miles and kilometres is done at the Mac-Monitor (see previous page). An arrow in top left corner of display indicates kilometres per hour is currently displayed.



SPEEDOMETER

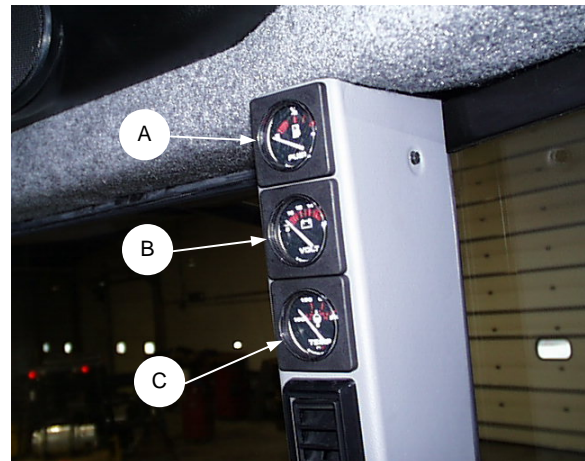

GAUGES

OPERATOR'S STATION

Ignition Switch

The ignition switch (A) has three positions; OFF, RUN and START.

The furthest counter-clockwise position of the key is OFF. Turn key fully clockwise to START. Holding key in this position will cause engine to crank.

Release of key will return to the vertical RUN position.

Lights

LIGHT SWITCH (B) - The light switch has four positions:

1. OFF - Furthest counter-clockwise position. To turn off all lamps.
2. FLASHER - To turn on flashing amber lamps and red tail lamps. (For use when windrower is being hauled by a towing vehicle.)
3. ROAD - To turn on head lamps, flashing amber lamps and red tail lamp. (For driving on roadways.)
4. FIELD - To turn on head lamps and field lamps. For field use ONLY.



CAUTION: When operating on a roadway, switch to the ROAD position. Never use field lamps or any lights which might confuse other drivers. Always use flashing amber lamps when driving or hauling on roadways, unless prohibited by law.

TURN SIGNAL SWITCH (C) - When operating windrower on a roadway, use turn signals as you would in a car or truck.

Turn signals will work with flashers on or off. Moving switch to left or right will flash turning side lamps with other side steady. An audible signal (beeper) will sound when turn signal switch is activated.

Turn indicators (D) are located on headliner.

NOTE: Be sure to return switch (C) to center position after turning.

DOME LIGHT (E) - Pushing button on dome light turns light ON and OFF.

REAR VIEW MIRRORS (F) - Adjust mirrors for best view.

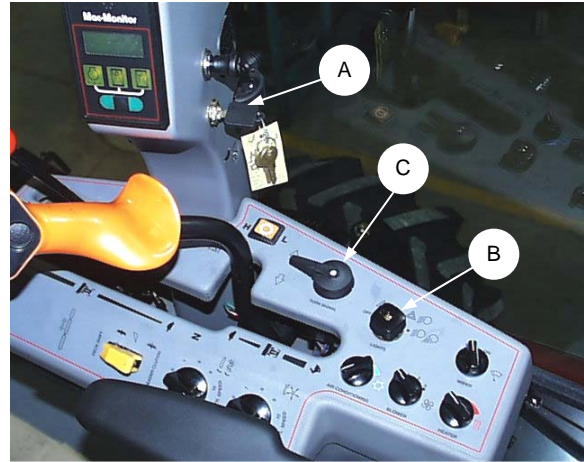

IGNITION SWITCH AND LIGHTS

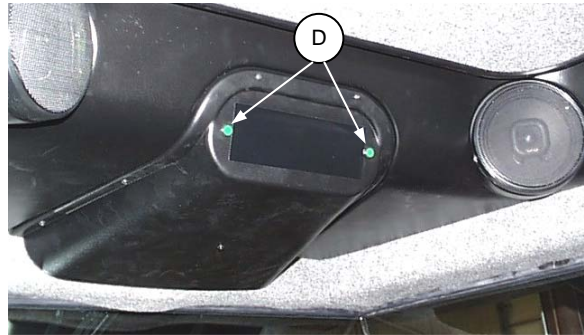

TURN INDICATORS

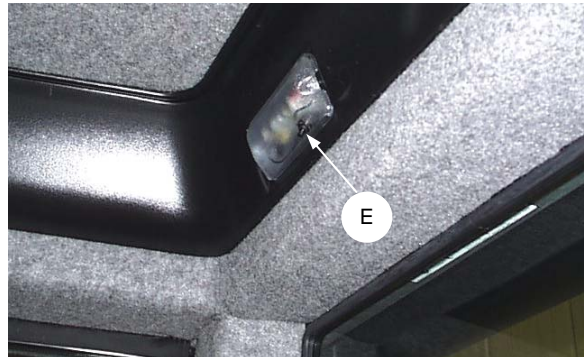

DOME LIGHT - RIGHT REAR CORNER

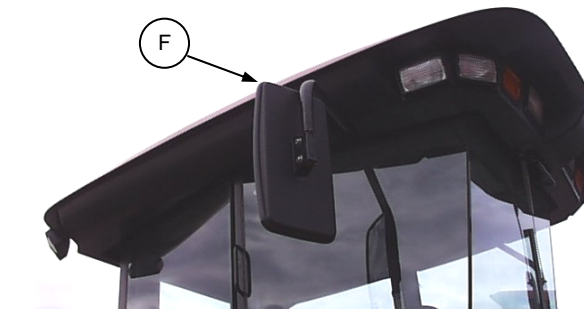

REAR VIEW MIRRORS

OPERATOR'S STATION

Cab Temperature Controls

NOTE: For access to circuit breakers, relays, fuses and other electrical components in cab side console, remove panel on window side of console.

BLOWER SPEED SWITCH (A) - Controls operation of blower. Four positions are: OFF, LOW, MEDIUM and HIGH. The blower recirculates cab air as well as drawing in outside air to pressurize the cab.

With door and window closed and blower on, dust and dirt will be filtered out to keep cab interior clean. Adjust louvers (B) (both sides of cab) to direct air where needed, for example, to defog window.

AIR CONDITIONING TEMPERATURE CONTROL (D)

Air conditioning is OFF when control (D) is turned fully counter-clockwise. Turning control clockwise decreases cab temperature. Blower switch (A) must also be turned ON before air conditioning system will operate.

Regulate cab temperature with air conditioning control and blower speed.

IMPORTANT: If humidity is high it may be necessary to run blower at HIGH speed to prevent evaporator freeze up.

HEATER TEMPERATURE CONTROL (E)

Heater is off when control (E) is turned fully counter-clockwise. Turning control clockwise increases cab temperature. Regulate cab temperature with heater control and blower speed.

NOTE: Heat and air conditioning systems are independent of each other. To avoid working one system against the other, be sure the system not in use is turned OFF at the appropriate temperature control, unless both are required to defog windows. There is also a shut-off valve for the heater circuit at the engine. Valve must be open for heater to function. For maximum cooling in hot conditions, turn handle fully in to close valve (G).

NOTE: If windows fog up, run the air conditioning to dehumidify the cab air, plus the heater to control cab temperature.

Windshield Wiper Control

Control windshield wiper using knob (F).

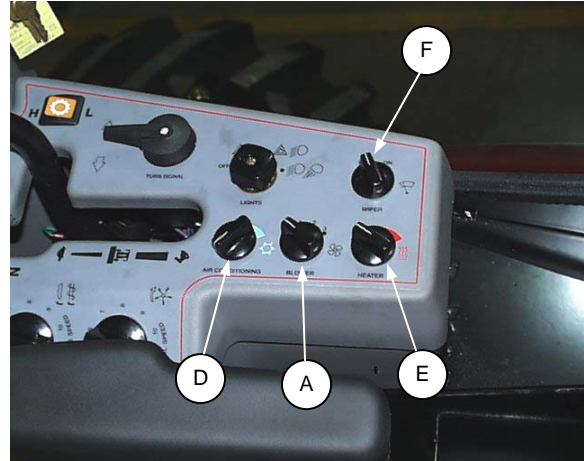

CAB TEMPERATURE AND WIPER CONTROLS

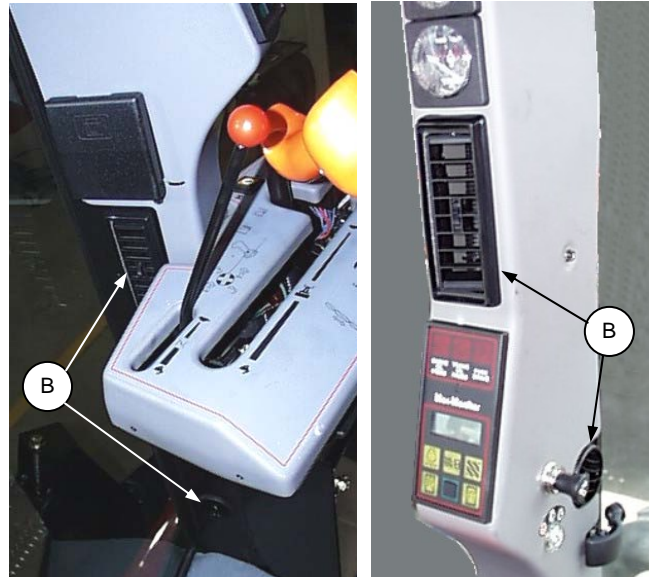

DIRECT AIR FLOW WITH LOUVERS

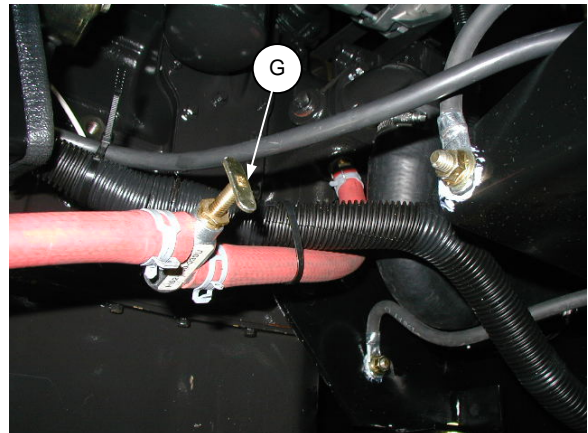

HEATER SHUT-OFF VALVE

OPERATOR'S STATION

Windrower Controls

VARIABLE GROUND SPEED CONTROL LEVER (A)

(A) Controls windrower direction of movement and rate of speed. A neutral start switch prevents the starter from engaging unless this lever is in the neutral detent as shown and the steering is locked in the straight-ahead position.

For forward motion: Push lever forward. The further the lever is moved from neutral the faster the speed. Release lever at desired speed and lever will engage friction device to secure the position.

For reverse motion: Pull lever rearward. The further the lever is moved from neutral the faster the speed.

SPEED-RANGE CONTROL (B) - Shifts the transmission to FIELD (Low) or ROAD (High) speed range.

Field Speed Range: This setting is for windrower operating speeds (0 - 9 mph [14.5 km/h]). Steering is less sensitive in this range.

Road Speed Range: This setting is for transport speeds (0 to 15.5 mph [25 km/h]). Steering is more sensitive in this speed range.

THROTTLE LEVER (C) - Push lever forward to increase engine speed (RPM) and rearward to decrease. Full forward is operating RPM.

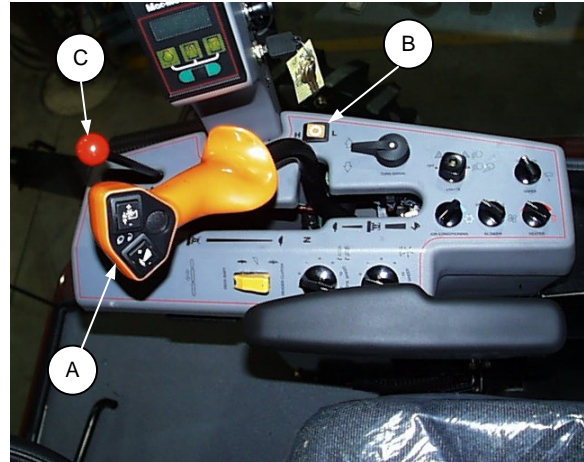

WINDROWER CONTROLS

STEERING WHEEL

To adjust steering wheel tilt:

1. Push and hold handle (F) down.
2. Move steering wheel to desired position.
3. Release handle to lock the position.

When exiting cab, push handle (F) down. This returns steering wheel to upright position for easier exit and re-entry.



STEERING WHEEL

OPERATOR'S STATION

Header Controls

NOTE: Some of these controls are not used for all types of headers. Some are optional equipment and may not be present in your unit. For others, while the switch may be installed, it will be non-functional for certain headers.

HEADER DRIVE SWITCH (A) - Lift the guard to expose toggle switch. Push toggle switch forward to engage all header mechanical and hydraulic drives. Push guard down to disengage drives. Starter will not engage if switch is in the engaged position.

NOTE: Always move throttle lever back to idle before engaging header drives. Do not engage with engine at full RPM.

NOTE: On 9352c, engine RPM max. is 2390 ± 50 RPM – with header engaged. With header disengaged engine RPM max. is 2530 ± 30 RPM.

CONVEYOR SPEED CONTROL (B) - Turn knob clockwise to increase conveyor speed and counter-clockwise to decrease. Speed range is:
940 Series Headers, Auger speed: 175 - 500 RPM
960/970 Series Headers, Draper speed:
170 to 500 ft/min (50 - 155 m/min)

REEL SPEED CONTROL (C) - Turn knob clockwise to increase reel speed and counter-clockwise to decrease. Speed range is:
920 Series Headers: 30 to 75 RPM
930 Series Headers: 30 to 69 RPM
940/960/970 Series Headers: 20 to 60 RPM

NOTE: 920/930 Series Headers – For these headers, both controls (B) and (C) affect reel speed. Set conveyor speed knob (B) to "10" and adjust reel speed knob (C) to obtain desired reel speed.

DECK SHIFT SWITCH (D) – Press left side of rocker switch to shift decks to the left and reverse draper travel. Press right side of switch to shift decks to the right and reverse draper travel. For center delivery, move rocker to center position.



HEADER DRIVE / CONVEYOR SPEED /
REEL SPEED / DECK SHIFT CONTROLS

OPERATOR'S STATION

Header Controls (continued)

REEL HEIGHT SWITCH (E) - Press top of switch to raise reel and bottom to lower. Hold switch until reel reaches desired position.

NOTE: For Auger Headers with Hay Conditioners equipped with **Hydraulic Roll Opener** cylinders, switch (E) controls the operation of these cylinders.

HEADER HEIGHT SWITCH (F) - Press top of switch to raise header and bottom to lower. Hold switch until header reaches desired position. (See "Cut Height Indicator").

NOTE: Handle may be rotated on lever to allow the operator to position switches (E) and (F) for maximum comfort. To adjust, loosen setscrews on back of handle.

IMPORTANT: Do not continue pressing switches (E) or (F) after header or reel travel is complete. If switch is held for a long period of time, damage may occur due to overheating electrical solenoids and/or over-heating hydraulic oil, which is pumped through relief valve.

HEADER EXPRESS DOWN

(Optional) – This dealer installed option is operated from switch (G). To activate the express down function, set switch (G) to “front down” position as shown. In this mode, it is not necessary to hold header height switch (F) to lower header fully. A momentary touch and release of the “down” side of switch (F) will fully retract header lift cylinders. To stop express down function in mid-travel, touch and release the “up” side of switch (F).

To bypass the express down function, set switch (G) to “rear down” position. Header height switch (F) will then operate as described at top of page.

REEL FORE-AFT CONTROLS (H) & (J)

(Optional) – For headers with hydraulic reel fore-aft option. Press button at (H) to move reel forward. Press button at (J) to move reel rearward.

HEADER TILT CONTROLS (K) & (L)

(Optional) – Press button at (K) to tilt header back for a flatter guard angle. Press button at (L) to tilt header forward for a steeper guard angle.

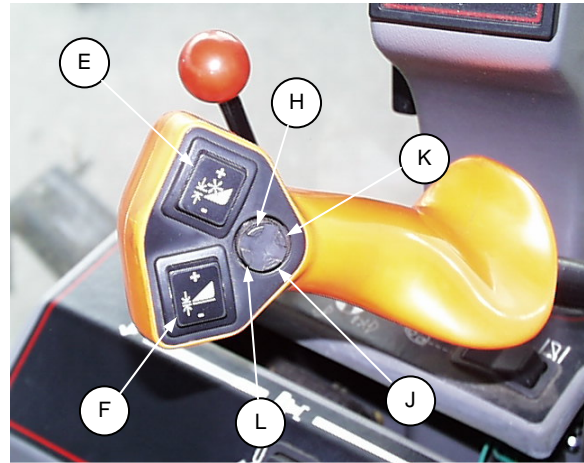

REEL & HEADER HEIGHT SWITCHES
REEL FORE-AFT & HEADER TILT CONTROLS



HEADER EXPRESS DOWN SWITCH

OPERATOR'S STATION

Header Controls (continued)

CUT HEIGHT INDICATOR (G) - The gauge on the lift linkage can be used to identify desired cut heights.

With the center link (between tractor and header) in a mid-range position, the numbers on the gauge indicate approximate cut (stubble) height in inches. Adjusting center link length will affect the starting point; eg. gauge reading 4 may indicate a 3" (longer center link) or 5" (shorter center link) cut height. However, the difference between gauge readings of 4 and 8, 8 and 12, etc. will always be about 4 inches, regardless of center link length.

Header Angle: Cut height indicator (G) can also be used to identify header angle when cutting with header on the ground. The gauge indicator will decline until header contacts ground, then as header height switch is held in down position, the indicator reading will increase as header angle steepens. The gauge numbers will not correspond to actual header angle, but can be used to identify a desired setting. See "Header Angle" in Operation section for adjustment procedure.



CUT HEIGHT INDICATOR

Seat Belts

The windrower is equipped with a seat belt on the Operator's and Trainer's seats.



WARNING: Before starting engine, securely fasten your seat belt and ensure trainer's seat belt is fastened if occupied. The seat belt can help insure your safety if it is used and maintained. Never wear a seat belt loosely or with slack in the belt system. Never wear the belt in a twisted condition or pinched between the seat structural members.

To fasten seat belt, pull belt completely across your body. Push the metal eye into the buckle until it locks. Adjust the position of the belt as low on your body as possible.

To release, push the red button in the end of the buckle and separate the buckle and metal eye.



SEAT BELT

OPERATOR'S STATION

Seat Adjustments

OPERATOR WEIGHT & SEAT HEIGHT

ADJUSTMENT - Press knob (A) in to increase suspension stiffness and seat height. Pull knob out to decrease.

SEAT-BACK ANGLE - Pull up on lever (B), position seat back as desired, and release lever.

LUMBAR SUPPORT - Rotate knob (C) to position lumbar support as desired.

SEAT FORE-AFT POSITION - To adjust, pull out on lever (D), move seat forward or rearward to desired position and release lever.

SEAT FORE-AFT ISOLATOR LOCKOUT - To lock out fore-aft isolator, push down on lever (E).

ARM RESTS - Left arm rest has two positions, vertical and horizontal. Raise left hand arm rest when leaving seat for easier exit and re-entry. Right arm rest is mounted on side console and is adjustable vertically at nuts (F) to operator preference.

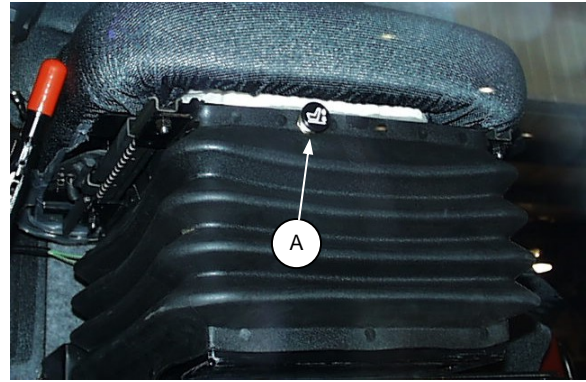

AIR SUSPENSION SEAT

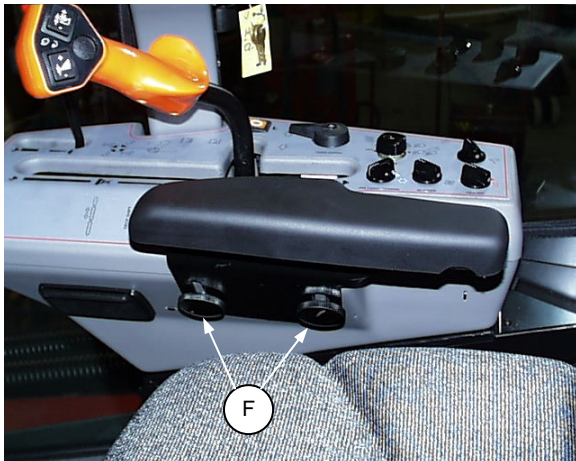

RIGHT ARM REST

TRAINING SEAT - Retractable training seat complete with seat belt is provided for use as described below. To extend, raise seat cushion and pivot front support down as shown. For storage, collapse front support and lower seat cushion.



WARNING: The training seat is provided for an experienced operator of the machine when a new operator is being trained. The training seat is **NOT** intended as a PASSENGER SEAT or FOR USE BY CHILDREN. **USE THE SEAT BELT** whenever operating the machine or riding as a trainer. **KEEP ALL OTHER RIDERS OFF THE MACHINE.**

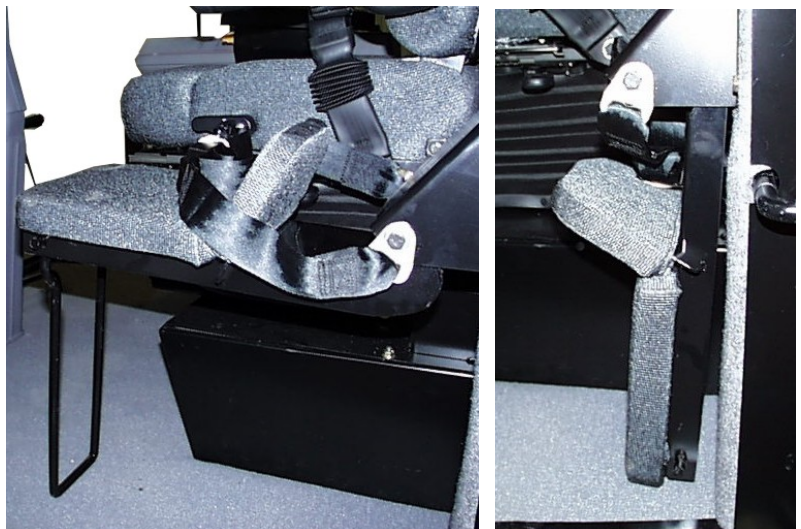

TRAINING SEAT

OPERATOR'S STATION

Operator Amenities

CUP HOLDER (A) – Provided at side console.



CUP HOLDER

CIGARETTE LIGHTER (B)

ASHTRAY (C)

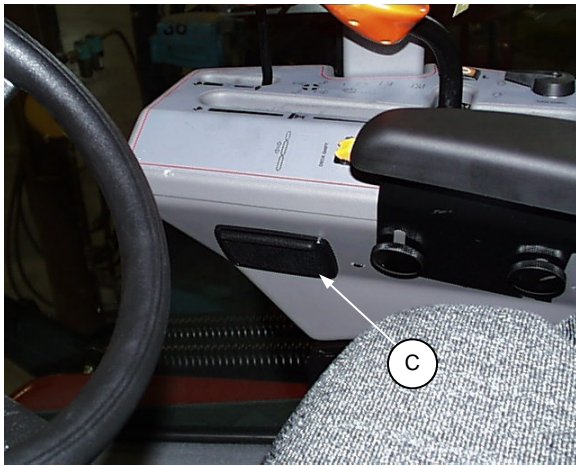

LIGHTER & ASHTRAY

AUXILIARY POWER POINTS (D) - Two 12 volt power outlets are provided on backside of console.

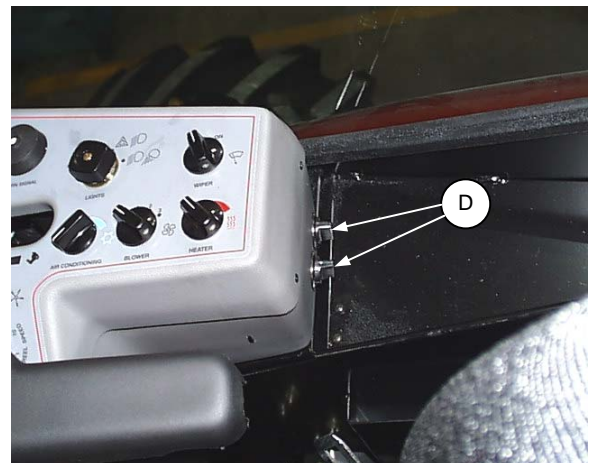

POWER POINTS

OPERATION

Your Responsibilities as an Owner/Operator



CAUTION:

1. It is your responsibility to read and understand this manual and the Header Operator's Manual completely before operating the windrower. Contact your dealer if an instruction is not clear to you.
2. Follow all safety messages in the manuals and on safety signs on the windrower.
3. Remember that YOU are the key to safety. Good safety practices protect you and the people around you.
4. Before allowing others to operate the windrower, for however short a time or distance, make sure they have been instructed in its safe and proper use.
5. Review the manuals, safety signs and all safety related items with all operators annually.
6. Be alert for other operators not using recommended procedures or not following safety precautions. Correct these mistakes immediately, before an accident occurs.
7. Maintain the windrower correctly. Be sure all controls are functioning properly before use.
8. Do not modify windrower or remove shields. Unauthorized modifications may impair the function and/or safety and affect machine life.
9. Install a fire extinguisher and keep it properly charged.
10. The safety information given in this manual does not replace safety codes, insurance needs or laws governing your area. Be sure your windrower meets the standards set by these regulations.



READ THE OPERATOR'S MANUAL

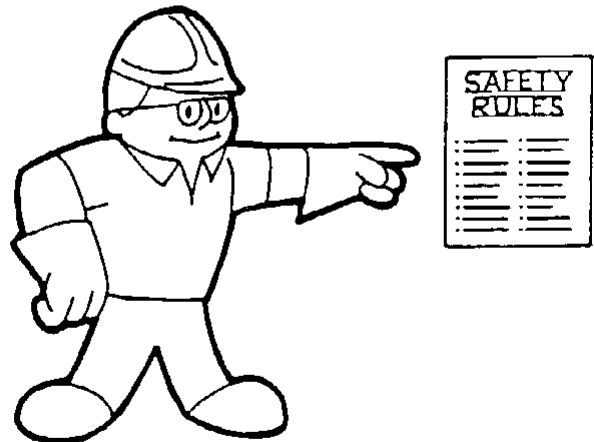

FOLLOW SAFETY RULES

To the New Operator

It's natural for an operator to be anxious to get started with a new machine. Please take the time to familiarize yourself with the windrower by reading the Operator's Manuals and safety signs before attempting operation. Study the Starting, Driving and Stopping procedures so you will know what to expect.

OPERATION

Break-in Period

The windrower is ready for normal operation. However there are several items to check and watch out for during the first 100 hours, as follows:

ENGINE BREAK-IN:

1. Operate engine at moderate load, avoid extremely heavy or light loading for longer than 5 minutes.
2. Avoid unnecessary idling. If engine will be idling for longer than 5 minutes after reaching operating temperature, turn key OFF to stop engine.
3. Check engine oil level frequently. Watch for any signs of leakage. If oil must be added, use oil specified under "Fuels, Fluids and Lubricants" in Maintenance/Service section.
NOTE: During the break-in period, a higher than usual oil consumption should be considered normal.
NOTE: If windrower must be driven in cold weather (below freezing), let engine idle for 3 minutes, then operate at moderate speed until oil has warmed up.
4. Watch coolant gauge in cab for temperature rising beyond normal operating range. Check that coolant level at reserve tank (mounted next to radiator) stays between HOT and COLD marks on tank. If overheating problems occur, check for coolant leaks. See "Cooling System" in Maintenance/Service section.
5. Change engine oil and filter after the first 50 hours and every 500 hours or at least once per season thereafter. See "Engine" in Maintenance/Service section.

WINDROWER BREAK-IN:

1. Until you become familiar with the sound and feel of your new windrower, be extra alert and attentive.
2. Check A/C compressor belt after 5 hours operation for initial stretch. Tighten as necessary. (See Maintenance/Service section). Continue to check the belt periodically for the first 50 hours.
3. Check drive wheel bolt torque according to the following schedule:
 - Every 15 minutes on the road or 60 minutes in the field until torque stabilizes, then
 - Daily (10 hours) until no change is recorded for 3 consecutive days (30 hours), then
 - Every 200 hours or annually thereafter.

Torque specification for drive wheels: 180 ft.lbs. (245 N.m).

Torque in numbered sequence shown and repeat sequence three times.

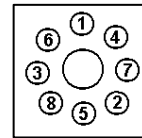

4. Check caster wheel bolt torque after the first 5 hours and every 200 hours or annually thereafter.
Torque specification for caster wheels: 100 ft. lbs. (135 N-m)
NOTE: To avoid damage to wheel disks, do not over-tighten wheel nuts.

5. Replace both hydraulic oil filters after the first 10 hours and every 300 hours thereafter. See "Hydraulic System" in Maintenance/Service section.
6. Change power hub oil after the first 50 hours and every 2000 hours (or annually) thereafter. See Maintenance/Service section.
7. Change bevel gearbox oil after the first 50 hours and every 200 hours (or annually) thereafter. See Maintenance/Service section.

8. Re-torque four walking beam pivot bolts (B) after the first 50 hours. Tighten to 265 ft. lbs. (360 N·m.)

NOTE: For units with optional "behind-frame" weight package as shown, tighten hardware to 350 ft. lbs. (470 N·m.)

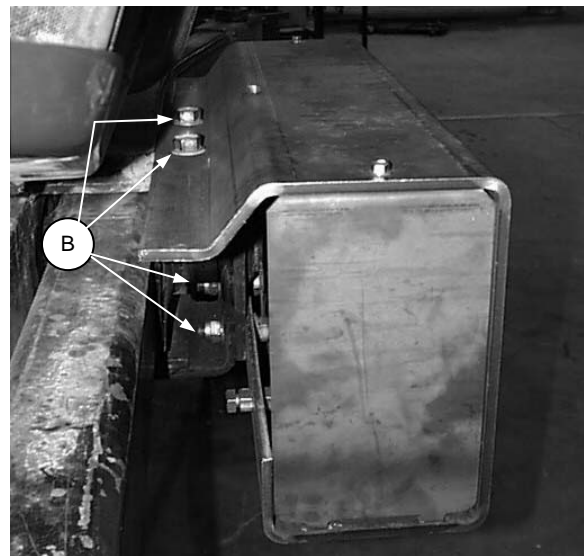

RE-TORQUE WALKING BEAM BOLTS
AFTER 50 HOURS

OPERATION

Pre-Starting Checks: Annual

Do the following at the start of each operating season:



CAUTION:

1. **Review the Operator's Manual to refresh your memory on safety and operating recommendations.**
2. **Review all safety signs and other decals on the windrower and note hazard areas.**
3. **Be sure all shields and guards are properly installed and secured. Never alter or remove safety equipment.**
4. **Re-acquaint yourself with the controls before beginning operation.**
5. **Store a properly stocked first aid kit and charged fire extinguisher on the windrower.**

Also:

6. Drain off excess hydraulic oil added for storage. See "Hydraulic System" in Maintenance/Service section.
7. Remove plastic bags and/or tape from all sealed openings (air cleaner intake, exhaust pipe, fuel tank).
8. Charge battery and install. Be sure terminals are clean and cables are connected securely.
9. Adjust tension on A/C compressor belt. See Maintenance/Service section.
10. Cycle blower switch to distribute A/C refrigerant oil. See Maintenance/Service section.
11. Perform all Annual maintenance. See Maintenance/Service section.

OPERATION

Pre-Starting Checks: Daily

Do the following each day before starting the engine:



CAUTION:

1. Clear the area of other persons, pets, etc. Keep children away from machinery. Walk around the windrower to be sure no one is under, on or close to it.
2. Remove foreign objects from the windrower and surrounding area.
3. Wear close-fitting clothing and protective shoes with slip resistant soles.

As well, carry with you any protective clothing and personal safety devices that **COULD** be necessary through the day. Don't take chances.

You may need:

- a hard hat
- protective glasses or goggles
- heavy gloves
- respirator or filter mask
- wet weather gear

4. Protect against noise. Wear a suitable hearing protective device such as ear muffs or ear plugs to protect against objectionable or uncomfortable loud noises.
5. Check the machine for leaks or any parts that are loose, missing, broken, or not working correctly. Use proper procedure when searching for pressurized fluid leaks. See "Fuel System" and "Hydraulic System" in Maintenance/Service section.
6. Clean the windows and mirrors to be sure of good visibility in all directions. To wash front window, stand on side platforms and use grab handle on cab side posts or on front of roof. Some headers are equipped with a traction surface across the back tube. If not, **DO NOT** stand on back tube of header.
7. Clean all lights and reflective surfaces to be sure you are visible to others.
8. Perform all Daily Maintenance. See Maintenance/Service section.

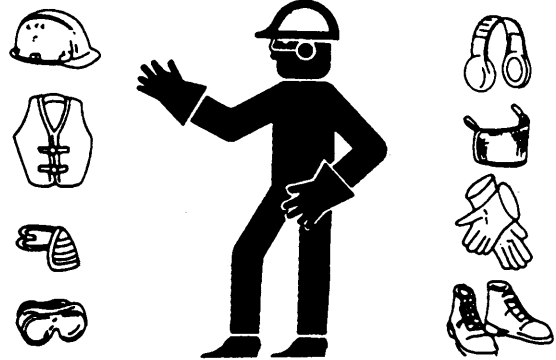

PROTECT YOURSELF



PROTECT AGAINST NOISE



WASHING FRONT WINDOW

OPERATION

Start-Up Procedure



DANGER: Avoid possible injury or death from a runaway machine.

Do not start engine by shorting across starter terminals. Machine will start in gear and move if normal starting circuitry is bypassed.

This machine has two safety devices which prevent the engine from starting unless the variable speed lever is in neutral, the steering wheel is locked in the neutral position, and the header drive switch is in the OFF position. Under no circumstances are these circuits to be deliberately rewired so that the engine can be started with controls out of neutral.

Start engine only from operator's seat with controls in neutral. **NEVER** start engine while standing on ground. Machine will start in gear and move if normal starting circuitry is bypassed.

Before starting engine, be sure there is plenty of ventilation to avoid asphyxiation.

IMPORTANT: Do not tow machine to start engine. Damage to hydrostatic drives will result.

ADJUSTING CONTROLS

1. Fasten seat belt.
2. Move header drive switch (B) to off position.
3. Move variable speed lever to neutral position (C).
4. Turn steering wheel until it locks. Adjust steering wheel tilt to desired position.
5. Move throttle lever (D) to start-up position - Lever fully back.

CHECKING INSTRUMENTS

The machine gauges and instruments provide important information about machine operation and condition. Familiarize yourself with the gauges and monitor them carefully during start-up operation. See "Instruments and Controls".



NEVER SHORT ACROSS STARTER TERMINALS



ADJUST CONTROLS FOR START-UP

OPERATION

Start-Up Procedure (continued)

STARTING ENGINE



CAUTION: Be sure the area is clear of other persons, pets etc. before proceeding.

Temperature above 16° C (60° F):

Turn ignition key to START position until engine starts. Release key. If engine does not start within 5 seconds of cranking, follow the start procedure that suits outside temperature as below.

Temperature between 5° - 16° C (40° - 60° F):

Move throttle lever (A) fully forward **after** turning ignition key to START position. When engine starts, release key and return throttle lever (A) to low idle.



WARNING: A grid heater is standard on your Cummins engine. However it is not activated because it has been determined that it is not required for windrower applications.

In the event that you decide to activate the grid heater do not use ether once the grid heater is activated as it may cause an explosion and possible injury.

IMPORTANT: Do not operate starter for longer than 15 seconds at a time. If engine does not start, wait at least two minutes before trying again. After the third 15 second crank attempt, allow solenoid to cool for 10 minutes before further cranking attempts. If engine still does not start, refer to Trouble Shooting section.



WARNING: If starter engages with steering wheel unlocked, variable speed lever out of neutral, or header clutch engaged, **DO NOT START ENGINE.** Perform Neutral Lock Adjustment. (See Maintenance/Service section.)

WARMING UP ENGINE

Allow engine to run with throttle lever (A) at or near low idle position until temperature gauge reaches approximately 180°F (80°C).

USING A BOOSTER BATTERY

If battery charge is low and engine fails to start, an extra 12-volt battery can be connected in parallel with the windrower battery. Follow directions carefully. See "Connecting Booster Battery" in Maintenance/Service section.

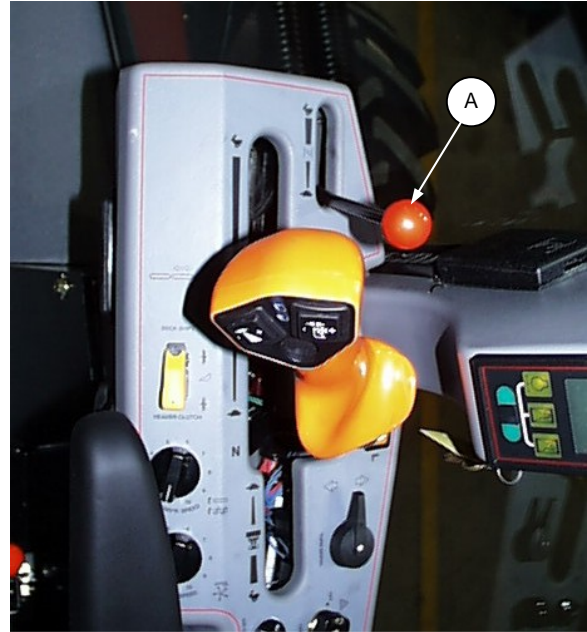

THROTTLE - IDLE POSITION

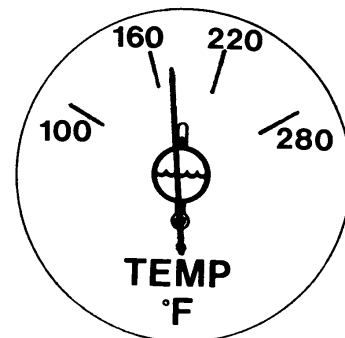

ALLOW ENGINE TO REACH OPERATING TEMPERATURE

OPERATION

Driving the Windrower



WARNING: • Avoid driving the machine with header removed. Removing header decreases the weight on drive wheels, reducing steering control.

- If necessary to drive machine with header removed, use transmission "field speed" range, do not exceed half maximum engine speed and avoid loose gravel and slopes.
- Never use windrower as a towing vehicle when header is removed. There is insufficient weight on the drive wheels to provide steering control.
- Because of windrower shape characteristics, a roll-over protected (ROPS) cab is not required. If operating with header removed, be aware that the cab structure will not withstand a roll-over.



CAUTION: HYDROSTATIC STEERING

The machine is steered hydrostatically, that is, turning the steering wheel varies the hydraulic flow to one drive wheel relative to the other drive wheel. The reaction of this type of steering is different than conventional steering mechanisms.

Remember:

- With the engine running and the variable speed lever in neutral, the machine will move if the steering wheel is turned.
- Hydrostatic steering is more sensitive than mechanical steering.
- Steering is opposite to normal when driving in reverse.



CAUTION: 1. Never move variable speed lever or steering wheel until you are sure all bystanders have cleared the area.

2. Be sure area is clear before making turns, ends of header travel in a large arc.
3. Check the operation of all controls in a safe, clear area before starting work. Be sure you know the capacity and operating characteristics of this machine.
4. Do not allow riders in or on the machine.
5. Operate only while seated in the operator's position.
6. Never attempt to get on or off a moving windrower.
7. Avoid sudden starts and stops.
8. Avoid inclines, ditches and fences.
9. Reduce speed when turning, crossing slopes, or travelling over rough ground.
10. Do not allow anyone to stand behind the machine while operating. Foreign objects may be forcibly ejected.



AVOID DRIVING WITH HEADER REMOVED

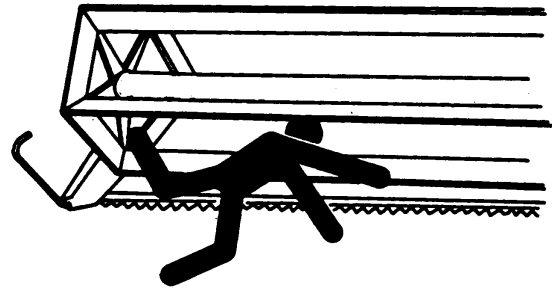

CLEAR THE AREA BEFORE OPERATING



DO NOT ALLOW RIDERS

OPERATION

Driving the Windrower (continued)

TO DRIVE FORWARD:

1. For field operation, set speed-range switch (A) to position **L**. For road speeds, set control to position **H**.
2. Slowly push throttle lever (C) to full forward (operating speed).

IMPORTANT:

- Return throttle lever (C) to low idle position before engaging header drives.
- For field operation, always operate windrower with speed-range control in field position and throttle lever fully forward (maximum engine RPM). Use controls to vary ground speed, reel speed and conveyor speed. All systems are designed for efficient operation at maximum engine RPM.



CAUTION: Check again to be sure all bystanders have cleared the area.

3. Slowly move variable ground speed lever (D) forward to desired speed.



CAUTION: Operate both steering wheel and variable speed lever slowly for familiarization. Remember that steering is more sensitive when speed-range control is in Road Speed Position. Avoid the common tendency of new operators to over-steer.

4. In situations where more tractive (lugging) power is required, for example, driving up a ramp, up a hill, or up out of a ditch:
Be sure speed-range control is in field position and move the variable speed lever towards neutral. The effect of this is similar to downshifting a standard transmission, increasing torque at the drive wheels.

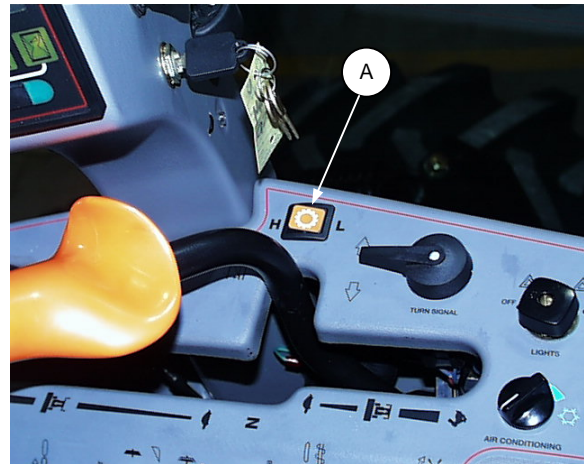

SPEED-RANGE CONTROL

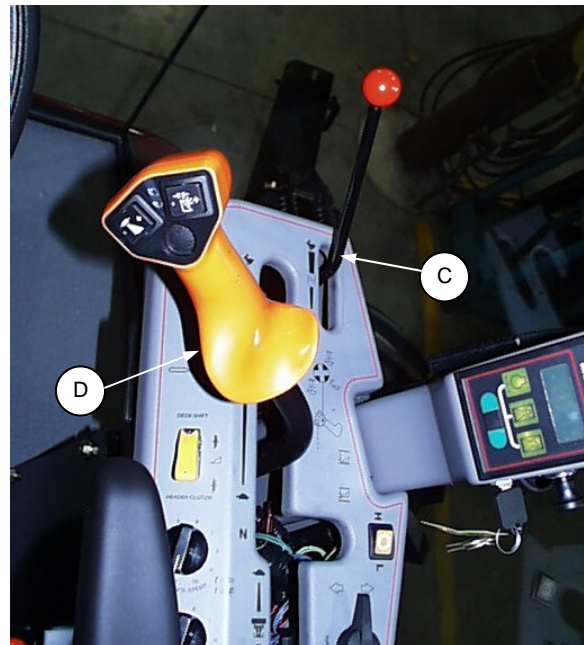

CONTROL LEVERS - DRIVING FORWARD

OPERATION

Driving the Windrower (continued)

TO DRIVE REARWARD:



WARNING: Back up slowly. Steering is opposite to normal when reversing. Hold steering wheel at the bottom and turn wheel in direction you want the rear of the machine to travel.

1. Move speed-range switch (A) to field position L.
2. Move throttle lever to a mid-range position (B).

NOTE: Reversing in low speed-range and at reduced engine speed is recommended since steering will be less sensitive than at higher speed settings.



CAUTION: Check again to be sure all bystanders have cleared the area.

3. Move variable ground speed lever (C) rearward to desired speed.

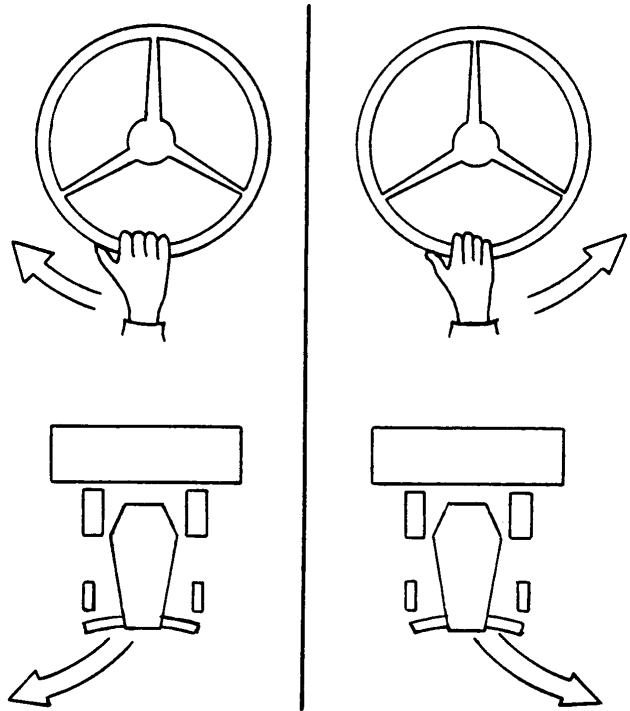

STEERING OPPOSITE TO NORMAL
WHEN REVERSING

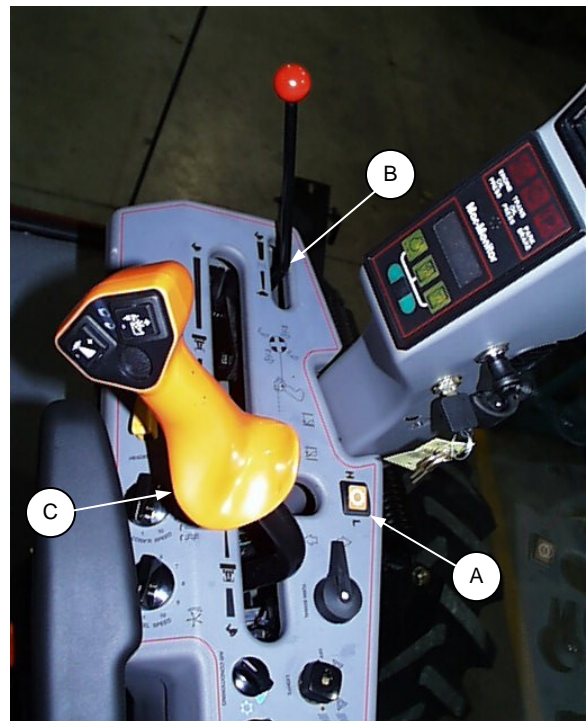

CONTROL LEVERS - DRIVING REARWARD

OPERATION

Driving the Windrower (continued)

MAKING A SPIN TURN:

Hydrostatic steering gives the operator significantly more maneuverability than mechanical steering.



CAUTION: Be sure area is clear before making turns. Although tractor pivots "on the spot", ends of header travel in a large arc.

To make a spin turn:

1. Move the variable speed lever (A) out of its neutral detent (towards the seat, not forward or rearward).
2. Slowly turn the steering wheel in the desired direction of turn. The windrower will pivot between the drive wheels.
3. To stop the turn, slowly turn the steering wheel back to its centered position.
4. To increase the turn radius, slowly move the ground speed lever away from neutral. Remember that this will increase ground speed as well.
5. To stop the turn, return all controls to neutral.

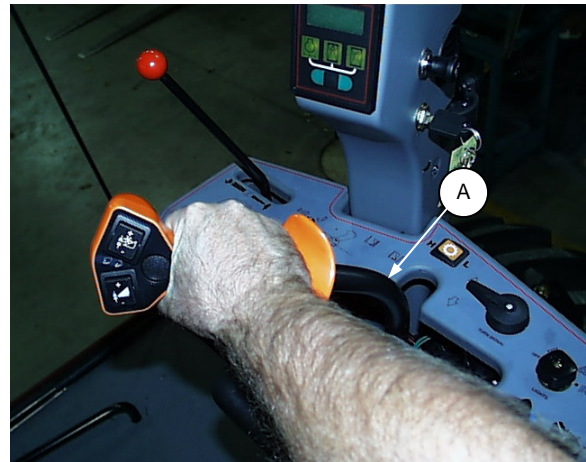

CONTROL LEVERS - SPIN TURN

OPERATION

Stopping Procedure

TO STOP WINDROWER:



WARNING: Do not move variable speed lever rapidly back to neutral. Operator may be thrown forward by sudden stop. Always wear seat belt when operating windrower.

1. To slow down and stop the windrower, SLOWLY return the variable speed lever (A) to neutral.
2. Turn steering wheel until it locks.
3. Move throttle lever (B) to low idle position.

NOTE: Avoid unnecessary idling. Stop engine if it will be idling for longer than 5 minutes.

4. Move header drive switch (C) to off position to stop header drives.
5. Brakes are automatically engaged when steering wheel is locked in neutral position.



CAUTION: Park machine on flat level ground only.



CONTROL LEVERS - STOPPING

TO STOP ENGINE:



CAUTION: Be sure windrower is safely parked on a flat, level surface, header on the ground and the neutral lock/brakes are engaged.

IMPORTANT: Before stopping engine, run at low idle for approximately five minutes to cool hot engine parts (and allow turbocharger to slow down while engine oil pressure is available).

1. Turn key counter-clockwise to OFF position.

OPERATION

Leaving the Windrower



CAUTION: Before leaving the operator's seat for any reason:

1. Park on level ground if possible.
2. Be sure variable ground speed lever is in the neutral detent and steering wheel is locked in the straight-ahead position.
3. Fully lower header and reel.
4. Disengage header drives.
5. Stop engine and remove key from ignition. A child or even a pet could engage an idling machine.
6. Turn off all lights (and wiper).
7. Release seat belt.
8. Raise armrest and steering wheel for easier exit and re-entry.
9. Lock the cab door when leaving the windrower unattended. (When the door is locked, it can still be opened from inside the cab.)
10. To provide more secure hand and foot mobility, preventing slipping and possible injury, always face the windrower and use the hand rail when dismounting (or mounting).

EMERGENCY EXIT

In case exit through cab door is not possible, the right hand side window may be opened to provide an emergency exit. Open window, then remove latch pivot pins (A) and push outward on window.

FOR NORMAL WINDOW OPERATION, open latches (B) and move window to open position.

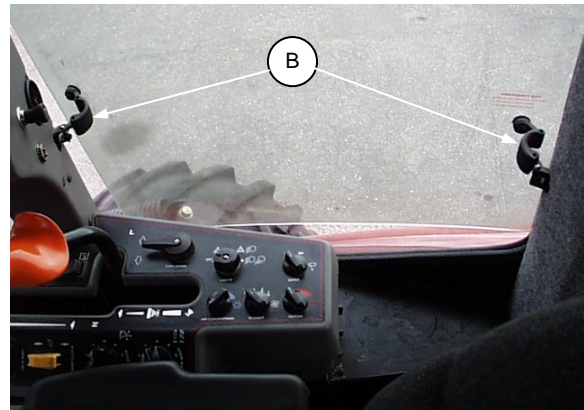

R/H SIDE WINDOW - EMERGENCY EXIT

OPERATION

Attaching the Header

NOTE: For Harvest Headers with gauge wheels, instructions under "Attaching" and "Detaching the Header" which refer to the "header stand" do not apply. Use the "stand" position of the gauge wheels to support rear of header. All gauge wheel positions are identified on a decal located at each gauge wheel. Be sure to reposition gauge wheel to field position before operating.

1. Choose an area that is as level as possible and set header stand (A) in the down position.

942 Header, set 2 inch (50 mm) blocks under each end of cutterbar.

960 & 970 Series Headers, be sure header and tractor have been properly prepared for windrower use.

See "Preparing Tractor and Headers" in Assembly section for details.

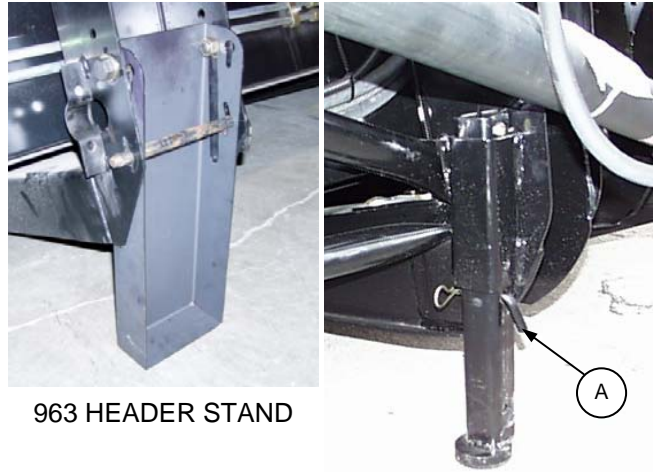

963 HEADER STAND

HEADER STAND - DOWN POSITION



CAUTION: Be sure area is clear of bystanders, then start engine.

2. Fully retract header lift cylinders. For units with Header Express Down option, use switch on side console to bypass the feature.

NOTE: For 30' & 36' Harvest Headers with Transport Option; when attaching to header in transport mode, position 6 inch high (150 mm) blocks for drive tires to provide adequate linkage height. Blocks should be at least the width of the drive tires and long enough that drive tires are fully supported when attaching header.

3. Slowly drive tractor forward so that lift linkage enters header legs. Continue to drive slowly forward until linkage contacts support plate in the lower header leg, and header nudges forward. Place variable speed lever into neutral position and lock steering wheel. Stop engine and remove key.

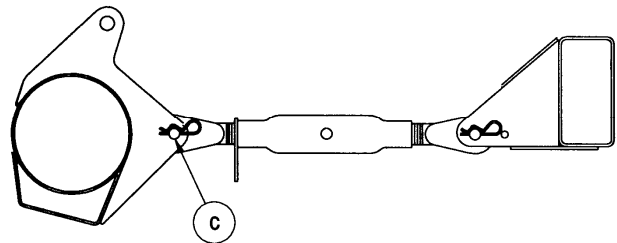

102995

INSTALL CENTER LINK

4. Adjust length of center link and connect to header at (C). For 962 and 972 headers, use the lower, more rearward hole in mount on header tube as shown.

NOTE: Ensure that thread length is equal at both ends of center link. See "Header Angle for adjustment details.

5. Check that bottom of linkage (D) is properly engaged in header leg, contacting support plate (E).

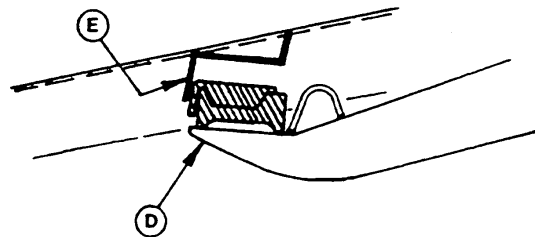

CHECK FOR PROPER ENGAGEMENT

OPERATION

Attaching the Header (continued)

6. Connect driveline to header drive shaft as follows:

- Open hinged shield at header drive shaft.
- Pull back spring loaded collar (G) on driveline yoke and slide yoke onto header shaft. Release collar, ensuring yoke locks in position on shaft.
- Attach chain hook (if present) to hinged shield at (H).
- Close hinged shield.

NOTE: For 962/963 Header only, attach chain hook (if present) to shield (J) on connector shaft as below.



CONNECT DRIVELINE – 962/963 HEADER

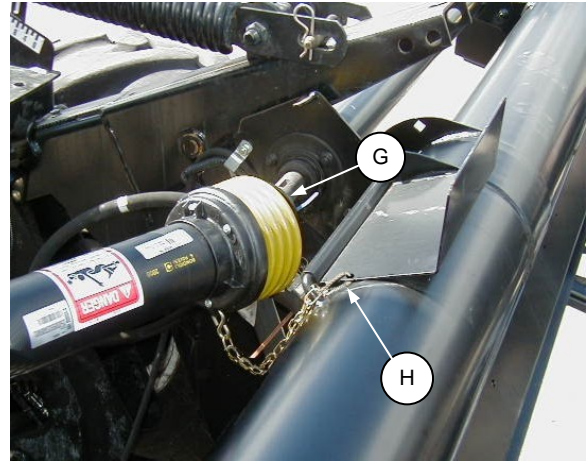

CONNECT DRIVELINE –
912/922/933/972 HEADERS

7. Hydraulic Hose Connections:

910 Series Headers: No hydraulic connections between header and tractor. Couple (A) to (B) and (D) to (E) for these units. Failure to do so will cause header drive circuit to overheat, causing potential hydraulic component failure or product performance problems.

920 & 930 Series Headers: Two connections are made at couplers (A) and (B) at the header right hand leg. One connection is made at coupler (D) at the header left hand leg. For 912 & 922 Headers with Hay Conditioner equipped with Hydraulic Roll Opener cylinders, connect hose from these cylinders at coupler (C).

940, 960 & 970 Series Headers: Two connections are made at couplers (A) and (B) at the header right hand leg. Two connections are made at couplers (C) and (E) at the tractor left hand leg. One connection is made at coupler (D) at the header left hand leg.

- A - reel drive pressure
- B - reel drive return
- C - reel lift (or Hay Conditioner Roll Opener cylinder circuit, if equipped)
- D - conveyor drive pressure
- E - conveyor drive return



HYDRAULIC CONNECTIONS - R/H SIDE

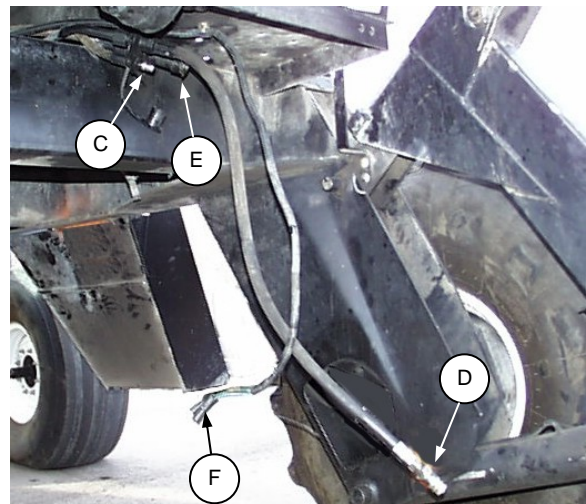

HYDRAULIC & ELECTRICAL CONNECTIONS
L/H SIDE

8. Connect the header electrical wiring harness at connector (F).

OPERATION

Attaching the Header (continued)

9. Start engine. Activate header lift cylinders (switch on ground speed lever) to raise header fully. Stop engine and remove key.

10.



DANGER: To avoid bodily injury from fall of raised header, always engage header lift cylinder stops (A) when working on or around raised header.

11. Attach float springs to front of linkage, both sides. Secure with "L" pin (B) and hair pin.

NOTE: For 12' & 15' 972 headers, connect pin at second hole (F) to ensure proper float.

12. Install pin through header leg, (engaging U-bracket in lift linkage), both sides.

910, 920, 930 & 940 Series Headers: Secure L-pin (C) behind lug (D).

962 Header: Secure 8" clevis pin with lynch pin.

912, 922, 933 & 970 Series Headers: Secure 6½" clevis pin (E) with split ring.

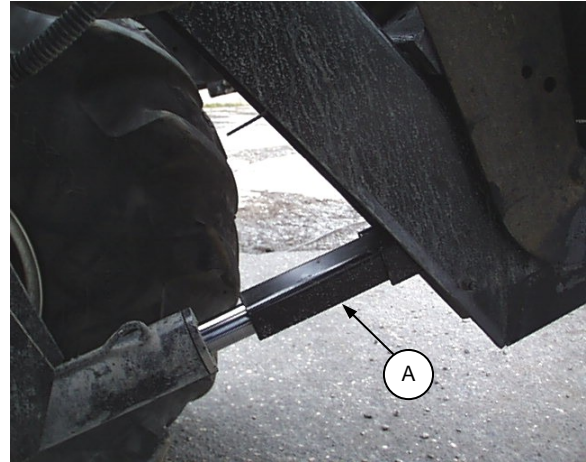

ENGAGE LIFT CYLINDER STOPS



ATTACH FLOAT SPRINGS

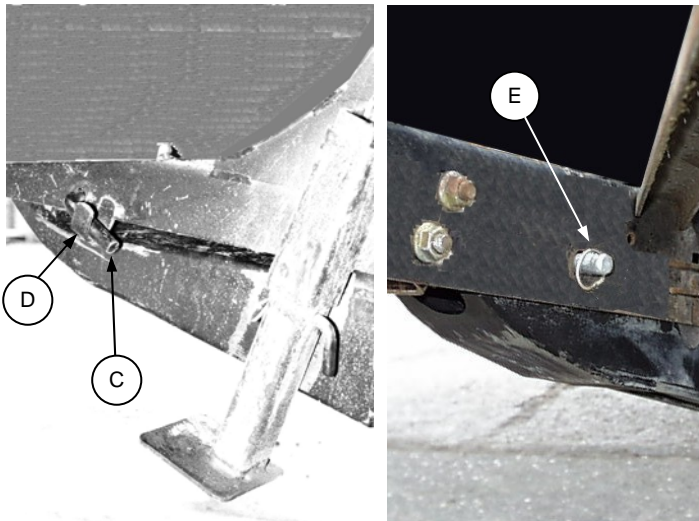

L-PIN DESIGN

CLEVIS PIN DESIGN

INSTALL PINS THROUGH LEGS

13. Raise header stand to storage position (F).

14. Disengage header lift cylinder stops and lower header to ground. Check header flotation and adjust if required. See "Header Flotation" in Operation section (page 49).

15. For headers with hay conditioner, attach forming shield rear support straps to forming shields.

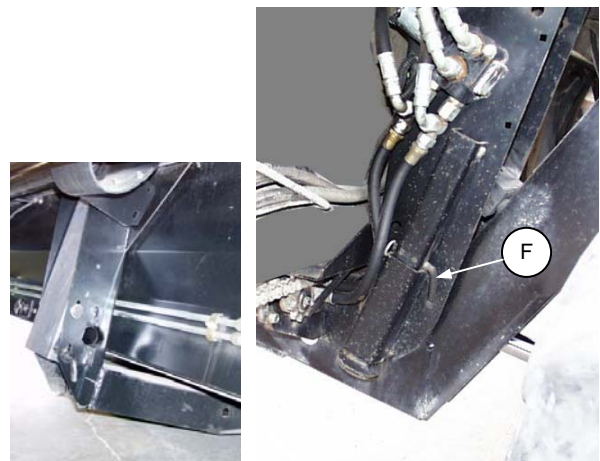

963 HEADER

OTHER MODELS

HEADER STAND - STORAGE POSITION

OPERATION

Adding Rear Weight

IMPORTANT: *The stability of the machine varies with different attachments, tractor options, terrain and operator's driving technique. Install weight at rear of tractor to provide adequate machine stability.*

To determine the additional rear weight required, pick the tractor model, header model and size to find your "base machine". Add up the values for the base machine plus options/conditions to obtain a score for a particular application. Go to the "score" column to determine which weight packages (if any) are required.

Header Model→	922 Auger Header			962/963 Harvest Header		972 Harvest Header (12' to 36') 973 Harvest Header (21' to 39')						
	14'	16'	18'	30'	36'	12'	15'	18'	21'	25'	30'	36'/39'
9352c**	90	96	101	70	114	No weights required	14	33	64	97	133	224
Base Machine	0	0	0	29	41		0	0	0	0	43	47
Pick Up Reel	0	0	0	0	0		0	0	14	15	17	19
Double Sickle	0	0	0	7	7		5	6	7	7	7	7
Cross Auger	0	0	0	0	0		30	30	30	30	0	0
Hay Conditioner	0	0	0	18	0		0	0	0	0	15	0
Gauge Wheels/ Transport	0	0	0	0	0		15	15	15	15	0	0
Gauge Rollers	43	43	43	43	43		43	43	43	43	43	43
Formed Casters	25	25	25	25	25		25	25	25	25	25	25
Hilly Terrain												

Score	Weights Packages Used	Weight Package Descriptions
0 - 114	No weights required	A = Two of B2266 are factory installed on 9352i** units. B = Basic weight bundle (B2980) added to the walking beam = 400 lbs. (180 kg). C = Additional weight bundle (B2981) added to the basic walking beam bundle = 300 lbs. (135 kg).
115 - 124	A	
125 - 134	2 of A	
135 - 164	2 of A plus B	
165 - 234	2 of A plus B plus C	
235 - 260 (see NOTE)	2 of A plus B plus C USE CARE	
Over 260 (see NOTE)	DO NOT USE THIS HEADER CONFIGURATION	

NOTE: For scores of 235 and higher, score may be reduced by having an authorized tire dealer install calcium chloride fluid in the rear caster tires as follows:

- To reduce score by 60 points: Install 250 lbs. (115 kg) in each 11 x 16 or 16.5 x 16.1 caster tire. (This is the maximum allowable for 11 x 16 tire.) Fluid can not be added to the 7.5 rear tire.
- To reduce score by 100 points: Install 400 lbs. (180 kg) in each 16.5 x 16.1 caster tire

** MacDon 9352c equivalent models are:

- Westward 9352c
- Prairie Star 4952c
- Premier 2952c
- Harvest Pro 8152c

OPERATION

Adding Rear Weight (continued)

To install weight bundle B2266 in rear tractor frame:

1. Install bolt (A) through welded nut in existing tractor weight (B) and start jam nut on bolt (A).
2. Insert weights (C) forward of welded pin (D) as shown, then move weight back towards rear of tractor.
3. After weights are in position, tighten bolt (A) against the new weight (C), then tighten jam nut against weight (B).

NOTE: Install complete weight pack on same side of pin (D). Total weight per pack is 187 lbs. (85 kg).

NOTE: Installation instructions for behind the frame weight packages B2980 and B2981 are included with the kits.

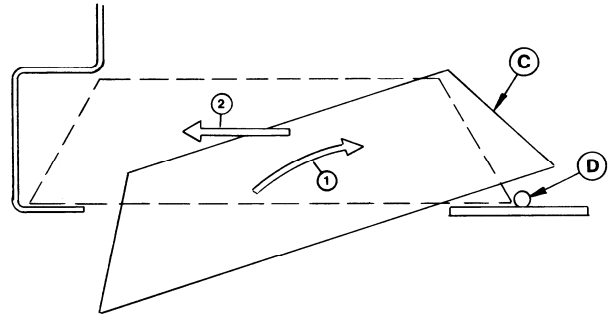

INSTALLATION OF WEIGHTS (REAR VIEW)

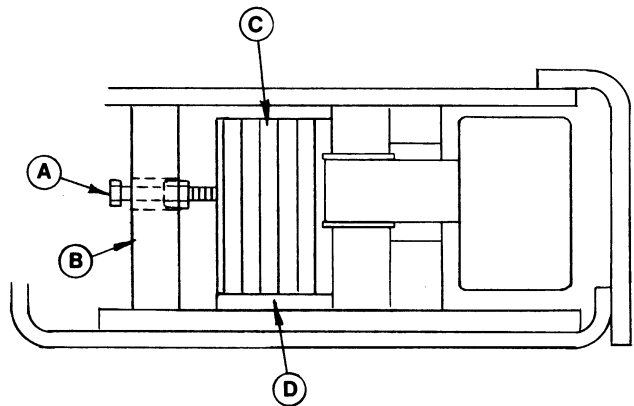

← direction of travel

OPTIONAL REAR WEIGHT PACK
(SIDE VIEW)

OPERATION

Detaching the Header

1. Activate header lift cylinders (switch on ground speed lever) to raise header fully. For units with Header Express Down option, use switch on side console to bypass the feature. Lower the reel (second switch on lever). Stop engine and remove key.

2.



DANGER: To avoid bodily injury from fall of raised header, always engage header lift cylinder stops (A) when working on or around raised header.



ENGAGE LIFT CYLINDER STOPS

3. Remove "L" pin (B), both sides and detach float springs.



DETACH FLOAT SPRINGS

4. Remove pin (C) from lower header leg, both sides.

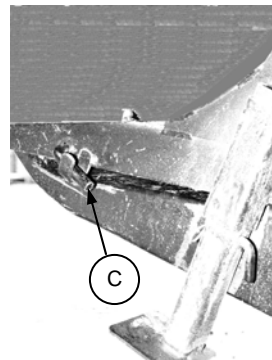

L-PIN DESIGN

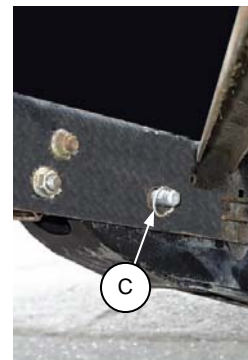

CLEVIS PIN DESIGN

REMOVE HEADER PINS

5. Lower header stand into position (E).

942 Multi-Crop Header: Place 2 inch (50 mm) blocks under cutterbar at both ends of header.

6. Disengage header lift cylinder stops.

7. Be sure area is clear of bystanders, then start engine. Retract lift cylinders to fully lower header. Stop engine and remove key from ignition.



963 HEADER STAND

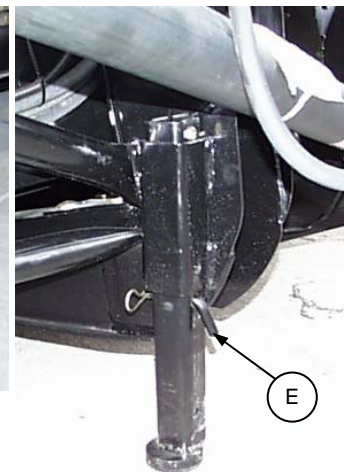

HEADER STAND - DOWN POSITION

OPERATION

Detaching the Header (continued)



DANGER: Wait for all movement to stop. A rotating driveline can cause entanglement resulting in serious personal injury or death.

8. Disconnect driveline from header shaft as follows:
 - Pull back spring-loaded collar on driveline yoke and remove yoke from header shaft.
 - Detach chain (if present) from header hinged shield.
 - Pull back spring-loaded collar and store driveline on pin welded to tractor frame at (E).

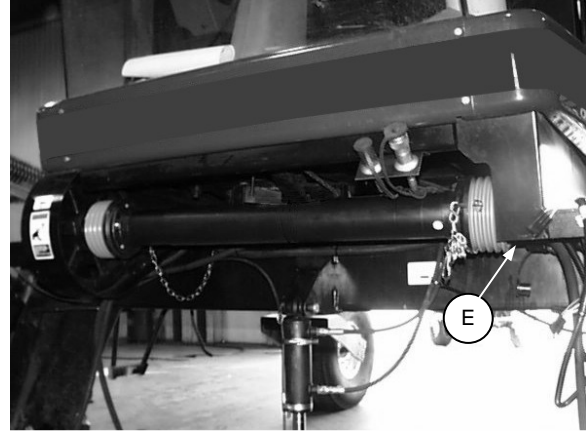

DETACH AND STORE DRIVELINE

9. Disconnect hydraulic hoses at quick couplers at right and left-hand legs.

IMPORTANT: Where possible, connect hoses to each other for storage except fore-aft as noted below. Plug or cap all other couplers to prevent hydraulic system contamination. Store tractor reel drive hoses as shown at (G) to avoid interference during hook-up.



WARNING: For headers with hydraulic reel fore-aft, never connect the header fore-aft couplers to each other. This would complete the circuit and allow the reel to creep forward in transport, resulting in instability.

10. Disconnect electrical wiring harness.

NOTE: If a Hay Conditioner is installed, detach supports between tractor frame and conditioner forming shield.



TRACTOR REEL DRIVE HOSES - STORAGE

11. Adjust length of center link to release load on pins. Disconnect center link at header by removing pin (C).

12. Slowly back tractor away from header. If hay conditioner is attached, watch clearances at left and right sides.



WARNING: Avoid driving the tractor with header removed. Removing header decreases the weight on drive wheels, reducing steering control. If necessary to drive tractor with header removed, use transmission low speed range, do not exceed half-maximum engine speed and avoid loose gravel and slopes.

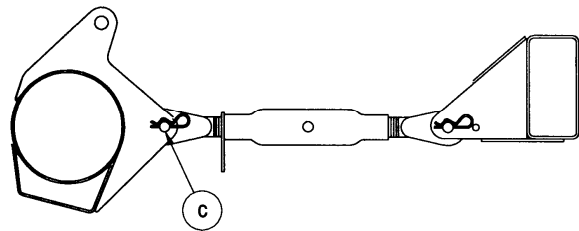

102995

DETACH CENTER LINK AT HEADER



WARNING: Harvest Header with Transport Option This windrower tractor is not intended as a towing vehicle for the Harvest Header Transport configuration. If necessary to use the tractor in this manner, add a minimum 2000 lb. (910 kg) counterweight on the lift linkage.

OPERATION

Operating the Header

Correct operation reduces crop loss and allows cutting of more acres. The length of service you receive from your windrower depends upon thorough lubrication, and proper maintenance and adjustments.



CAUTION: Do not mount anything on the windrower tractor except the headers and attachments designed for use with it. Unapproved attachments may change the stability and controllability of the machine.

Header Lift Cylinder Stops



DANGER: To avoid bodily injury or death from fall of raised header, always engage cylinder stops before going under header for any reason.

Cylinder stops are located on both header lift cylinders on windrower.

To engage cylinder stops:

1. Press top of header height switch (A) to raise header to maximum height.
2. Lift retainer (B) up to release cylinder stop (C). Lower stop onto cylinder.
3. To store, push up on stop (C) until retainer locks in storage position.

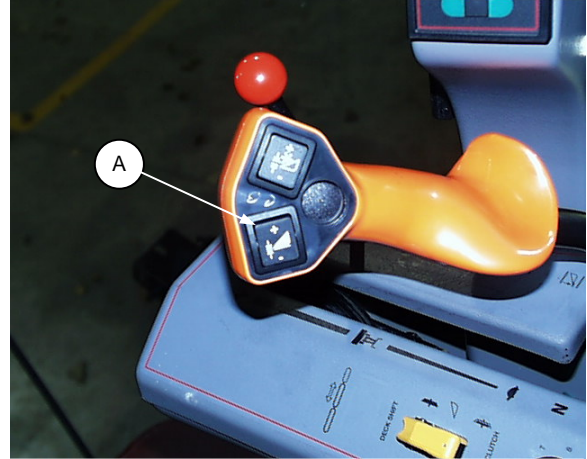

HEADER HEIGHT SWITCH

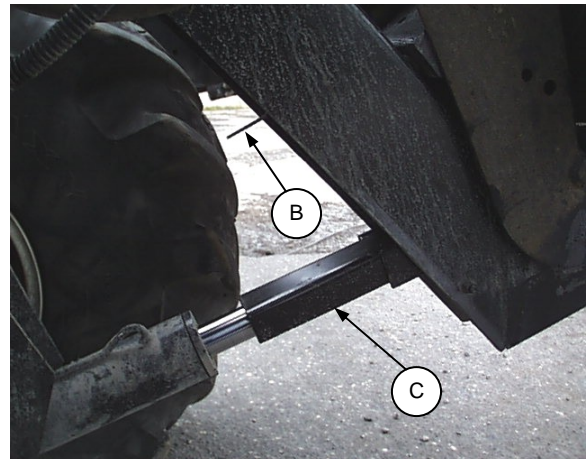

LIFT CYLINDER STOP - ENGAGED



LIFT CYLINDER STOP - STORAGE

OPERATION

Header Angle

Header angle is adjustable by changing the length of the center link between header and tractor.

Header angle adjustment ranges:

910, 920, 930 Series Headers: 8° to 16°

940 Series Headers: 6° to 13°

960 Series Headers: 13° to 21°

970 Series Headers: 9.5° to 21°

NOTE: Above figures are guard angle in degrees below horizontal.

IMPORTANT: A flatter header angle is recommended for normal conditions. A flatter angle reduces sickle section breakage and reduces soil build-up at the cutterbar in wet conditions.

Use a steeper angle to cut very close to the ground, or for better lifting action of down crops.

IMPORTANT: Changing header angle will affect flotation. Steepening the header angle makes header heavier while flattening the header angle makes header lighter. Always check flotation after adjusting header angle.

To adjust header angle with mechanical link:

1. Unlock collar (C) by tapping it in a counter-clockwise direction.
2. Using a long punch in hole (D), turn the center link until the desired header angle is reached. Shortening the link will give a flatter header angle, while lengthening the link provides steeper angles.
3. Lock collar (C) against link body by tapping in a clockwise direction to secure the position.

HEADER TILT HYDRAULIC ADJUSTMENT

An optional kit is available which allows adjustment of header angle from the cab by means of a hydraulic cylinder.

See "Options and Attachments" section for order numbers. See "Header Controls" in Operator's Station section for identification of hydraulic header angle controls.

IMPORTANT: For units with hydraulic header tilt option, be aware that when cutting on the ground and using the hydraulic center link to adjust header angle on the go, the flotation will be affected. To prevent excessive guard breakage when conditions are not suited to heavier float (e.g. rocky or wet), do not use the tilt control on the go. Instead, use the header height switch as described below.

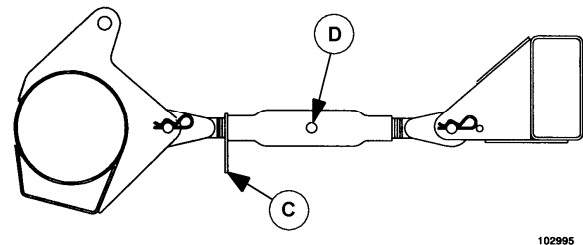

HEADER ANGLE MECHANICAL ADJUSTMENT

To adjust header angle when cutting on the ground (without hydraulic option):

When cutting with header on the ground, the header height switch can be used to adjust header angle "on the go". Familiarize yourself with how the header reacts during this adjustment to take full advantage of the feature.

1. Lower header by pressing bottom of header height switch until cutterbar just touches ground. At this point, cutterbar is at the flattest guard angle.
2. If a steeper angle is desired, continue pressing bottom of switch. This will steepen the guard angle until lift cylinders are fully retracted.
3. To adjust angle from steeper to flatter, press the top of the header height switch to extend cylinders a small amount. Once the flattest angle is reached, further activating the switch will lift the cutterbar off the ground.

Use this adjustment in combination with the center link adjustment (above) to achieve the desired range through which the header angle moves before header lifts off the ground.

See "Header Controls" in Operator's Station section for use of header height switch and cut height indicator with regard to header angle.

OPERATION

Header Levelling

A 1/4 inch (6 mm) shim (A) is located on both sides of windrower lift linkage. If header is not level, adjust as follows:

1. Lower header onto a block so back of linkage lifts.
2. Remove hardware (B) on the high side of the header and remove shim (A). Replace hardware (B).
3. Check header level. If more levelling is required, install the removed shim on opposite side of linkage, adding it to the existing shim.
4. If header is still not level, additional shims are available from your dealer.

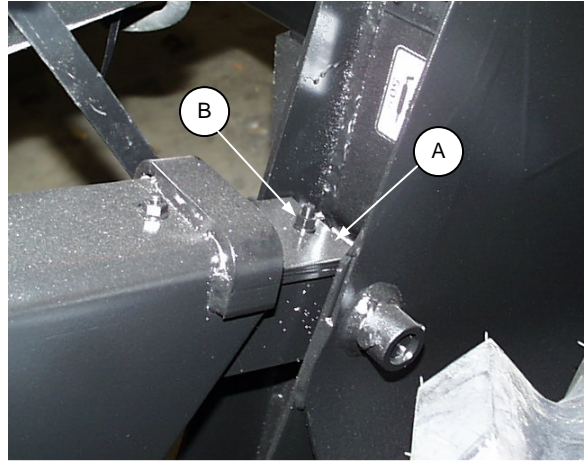

HEADER LEVELLING

OPERATION

Header Flotation

The following suggested header float settings are a starting point for normal conditions. Your specific requirements and conditions may require heavier or lighter float.

Force required to lift the cutterbar off ground at each end of the header (with lift cylinders fully retracted):

910/920/932 Auger Headers: 100 to 120 lbs. (445 - 535 N)

912/922/933 Auger Headers & 942 Multi-Crop Header: 75 to 85 lbs. (335 - 380 N)

Draper Headers: 50 to 70 lbs. (220 - 310 N)

Benefits of lighter float settings:

1. Less cutting component breakage in rough or stony conditions.
2. Avoids soil build-up at cutterbar in wet conditions.

Benefits of heavier float settings:

1. When cutting very close to the ground, enables the cutterbar to follow ground contours.

NOTE: For all headers except 12' & 15' 972 Header, use top hole (A) in float linkage. For 12' & 15' 972 Header, use lower hole (B).



USE HOLE "B" FOR 12' & 15' 972 HEADER

To adjust header float:

NOTE: Because of end-to-end weight differential, dimension (C) at left and right drawbolt will be different to achieve equal float at both ends of header. Also, lighter headers will require a larger dimension (C), heavier headers a smaller dimension (C).

1. Raise header fully, shut off engine, remove key.
2. Loosen nut (D).
3. Turn spring drawbolt (E) clockwise to increase float (which makes header lighter when lowered to ground).
Turn bolt counter-clockwise to decrease float (which makes header heavier when lowered).
4. Tighten nut (D) to lock position.
5. Lower header fully and check float at both ends of cutterbar. Force required to lift cutterbar should be approximately the same at both ends.

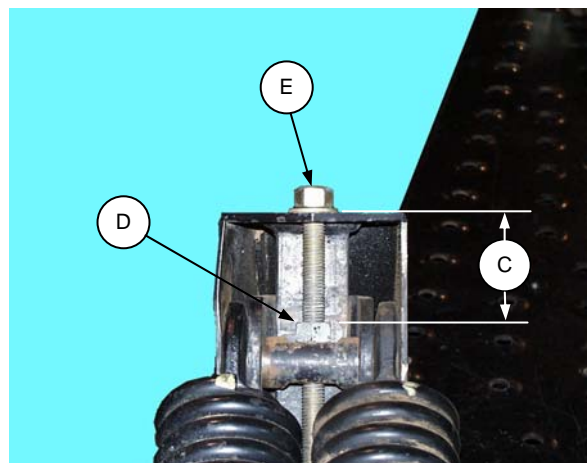

FLOAT ADJUSTMENT

IMPORTANT: Spring loaded gauge wheels (available on some draper headers) have an effect on header float. See "Header Flotation" in your header operator's manual for details.

OPERATION

Transporting the Windrower



WARNING: Do not drive windrower on a road or highway at night, or in conditions which reduce visibility, such as fog or rain. The width of the windrower may not be apparent under these conditions.



WARNING: Avoid driving the tractor with header removed. Removing header decreases the weight on drive wheels, reducing steering control. If necessary to drive tractor with header removed, use transmission low speed range, do not exceed half maximum engine speed and avoid loose gravel and slopes.



WARNING: Harvest Header with Transport Option:

This windrower tractor may be used to tow 21' & 25' harvest headers when a MacDon approved towing package and weight box are used.

Do not use this windrower tractor to tow 30', 36' or 39' harvest headers. Instead, refer to the 30/36/39' header manuals for instructions on towing these headers.



CAUTION:

1. Check local laws for width regulations and lighting or marking requirements before transporting on roads.

2. Move header drive switch (A) to off position.



WARNING: To avoid possible loss of control, set ground speed lever to not more than half maximum forward speed before changing speed-range switch position.

3. For road speeds, move speed-range switch (C) to road (high) position. Remember steering is more sensitive in this speed range.

4. Before driving windrower on a roadway, be sure flashing amber lamps, red tail lamp and head lamps are clean and work properly. Turn light switch (B) to ROAD position to activate these lamps. Always use these lamps on roads to provide warning to other vehicles.

5. Do not use field lamps on roads, other drivers may be confused by them.

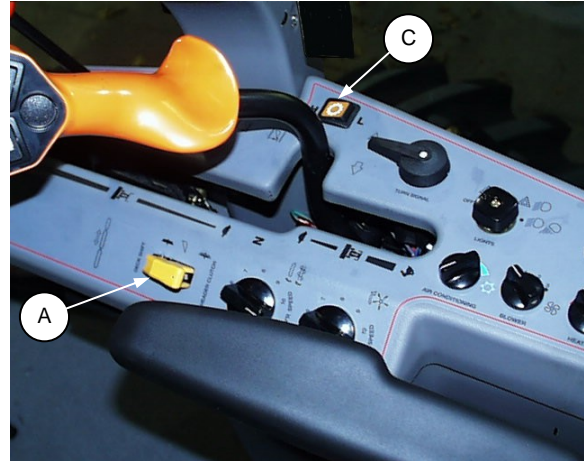

HEADER DRIVE SWITCH OFF & SPEED-RANGE SWITCH TO HIGH

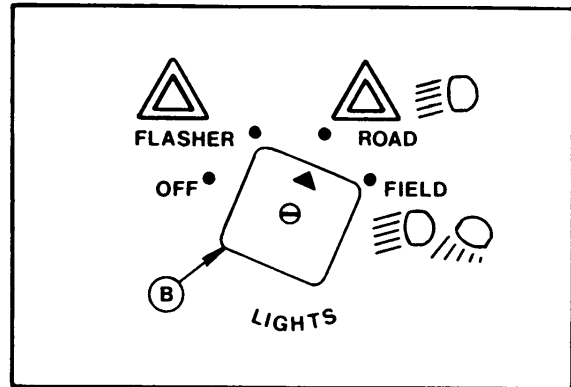

LIGHT SWITCH TO "ROAD" POSITION

6. Before driving windrower on roadway, clean all reflective surfaces and slow moving vehicle emblem at rear of machine. Adjust rear view mirror and clean windows.
7. Transport windrower with header fully raised and reel fully lowered. Maintain adequate visibility and be aware of roadside obstructions, oncoming traffic and bridges.
8. When travelling down hill, reduce speed and keep header at a minimum height. This provides maximum stability if forward motion is stopped for any reason. Raise header completely at bottom of grade to avoid contacting ground.
9. Travel speed should be such that complete control and machine stability are maintained at all times.
10. Stop, look and listen before entering a roadway. Stay on correct side of the road and pull over if possible to let faster traffic pass. Slow down and signal as you turn off.

OPERATION

Transporting the Windrower

TOWING THE WINDROWER ON A TRAILER

For transporting the windrower other than under its own power, a side mount trailer (A) carrying all four windrower wheels is recommended.

Also acceptable are side mount trailers (B) where the windrower tail wheels remain on the ground. For this type, tighten caster set screws, step 7, below.

For narrower headers, front or rear mount trailers may be used, providing local laws regarding width regulations are adhered to.



WARNING: When towing the windrower on a trailer:

1. Keep header fully raised and reel fully lowered.
2. Chain windrower securely to trailer. Run chains through triangular brackets (C) at rear of tractor frame legs and through anchor (D) at rear of frame. Be sure windrower weight is centered on trailer for stable load. Block drive wheels to prevent movement.
3. Transport width is approximately 20 ft. (6.1 m). Check local laws for width regulations and lighting or marking requirements.
4. Remember that when towing windrower sideways or backwards, slow moving vehicle emblem, reflectors and warning lights are not easily visible. It is your responsibility to adequately mark the load when transporting in this fashion.
5. Set light switch to **FLASHER** position to activate amber lamps.
6. Do not tow the windrower on a roadway at night, or in conditions which reduce visibility, such as fog or rain. The width of the load makes it unsafe to transport under these conditions.
7. If towing at speeds over 16 mph (26 km/h), on a type (B) trailer:
 - a. Align caster wheels with trailer wheels.
 - b. Tighten caster setscrews (E) to 20 ft. lbs. (27 N.m) to prevent erratic movement of the casters. Failure to do this will result in caster damage and could cause loss of control.
 - c. Loosen setscrews after transport.

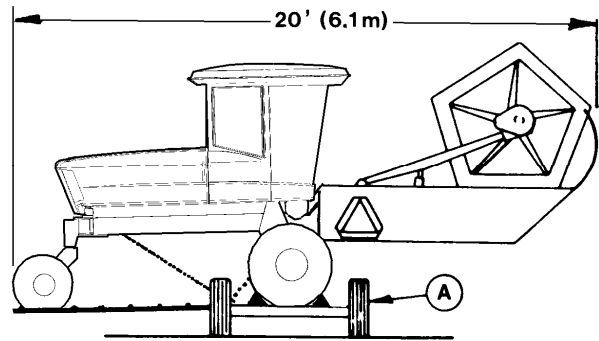

SIDE MOUNT TRAILER - TYPE (A)

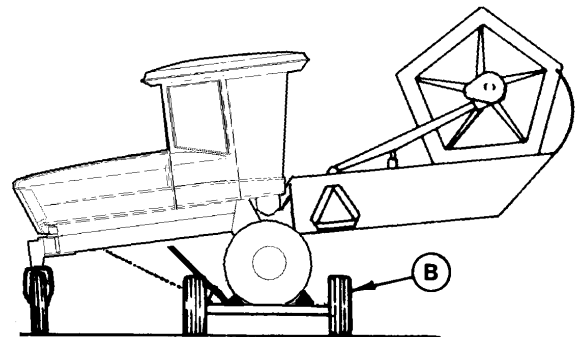

SIDE MOUNT TRAILER - TYPE (B)

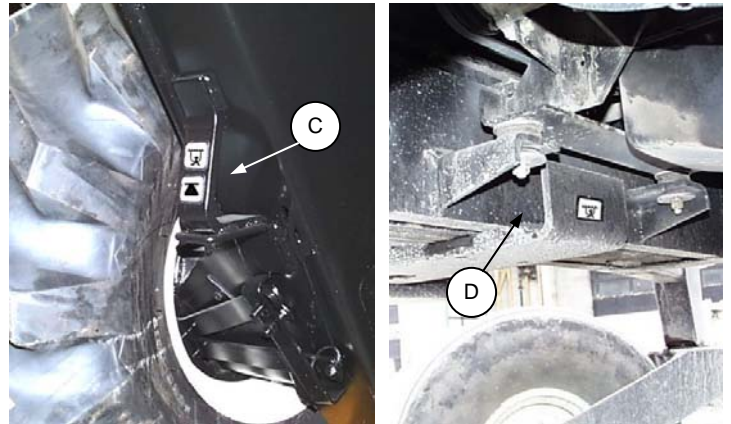

CHAIN WINDROWER TO TRAILER

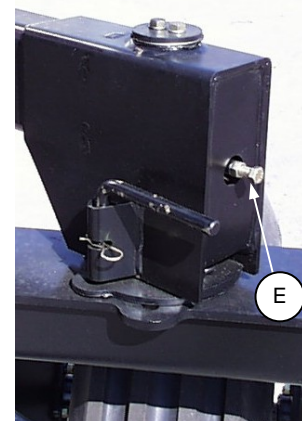

CASTER SETSCREWS

OPERATION

Transporting the Windrower

TOWING THE WINDROWER ON A TRAILER (continued)



WARNING: When towing the windrower on a trailer (continued):

8. When towing on a front or rear mount trailer, lock casters in a straight-ahead or straight-back position with L-pin (F). Secure L-pin with hairpin in lock or storage position. (See storage position, lower right photo on page 52.)
9. Do not tow at speeds over 25 mph (40 km/h). Travel speed should be such that complete control and stability are maintained at all times.
10. Be aware of roadside obstructions, oncoming traffic and bridges. Take care when travelling over rough terrain or on slopes.
11. Be sure the total weight of the trailed vehicle **NEVER EXCEEDS** the weight of the towing vehicle, unless the trailed vehicle is equipped with remote brakes.

NOTE: Windrower weighs 8000 to 10000 lbs. (3600 to 4500 kg) depending on header size.

Stopping distance increases with increasing speed as the weight of the trailed vehicle increases, especially on hills and slopes.

12. **IMPORTANT:** Before towing, plug or cover muffler exhaust to prevent the turbine from turning without lubrication. This "free-wheeling" of the turbocharger can cause damage.



CASTER TRANSPORT LOCK

OPERATION

Transporting the Windrower

TOWING WINDROWER WITHOUT TRAILER

The best method for transporting a disabled windrower is to haul it on a suitable trailer or flatbed. (See Towing Windrower on a Trailer.)

In emergency situations, for example, towing out of a field or into a shop, windrower may be towed without a trailer, providing the following precautions are followed:

1. Attach windrower to towing vehicle.



WARNING: A proper towing apparatus is critical to safe towing. Use the following guidelines:

- Do not attach directly from hitch to walking beam (B). Slope of tow bar will not provide proper transfer of braking force to windrower, causing loss of control.
- For proper steering, towing apparatus should be attached to both left and right hand frame members (C) and should attach to tow bar at same height (D) as towing vehicle hitch.
- Towing apparatus should be removed for field operation, to avoid interference with windrow.



CAUTION: With final drives disengaged, the windrower may roll on a sloped surface. Before disengaging final drives, attach windrower to towing vehicle. After towing, engage drives and park brake before detaching from towing vehicle.

2. Disengage final drives:
 - Remove cover (A) at center of drive wheels.
 - Replace with dished side facing in.

IMPORTANT: Failure to disengage final drives before towing will result in serious transmission damage.

Do not exceed 16 mph (26 km/h) when towing windrower. Do not use this towing method for normal transporting of windrower. *Even with final drives disengaged, rolling speeds of more than 16 mph (26 km/h) will cause final drive gears to run at excessive speeds, possibly destroying the unit.*

After towing, reverse cover (A) to re-engage final drives. Be sure plunger at center of wheel pops out to engage drive.

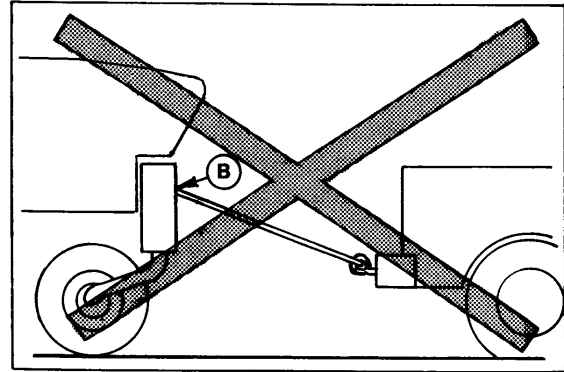

DO NOT ATTACH TO WALKING BEAM

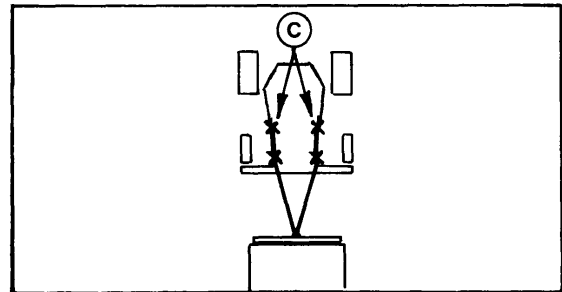

ATTACH TOWING APPARATUS TO FRAME

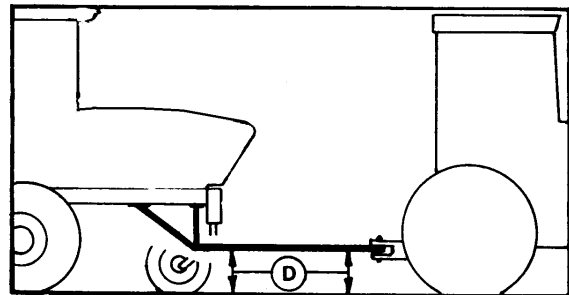

TOW BAR PARALLEL TO GROUND



DISENGAGE FINAL DRIVES

OPERATION

Transporting the Windrower

TOWING WINDROWER WITHOUT TRAILER (continued)



WARNING: When towing the windrower without a trailer:

3. Lock casters in a straight-ahead or straight-back position with L-pin (F). Secure L-pin with hairpin in lock or storage position. (See storage position, lower right photo on page 52.)

4. Be sure the towing vehicle is heavier than the windrower.

NOTE: Windrower weighs 8000 to 10000 lbs. (3600 to 4500 kg) depending on header size.

Remember stopping distance increases when towing, especially on hills and slopes.

5. Do not exceed 16 mph (26 km/h) when towing windrower.
6. Remember that when towing windrower backwards, slow moving vehicle emblem, reflectors and warning lights are not easily visible. It is your responsibility to adequately mark the load when transporting in this fashion.
7. Set light switch to FLASHER position to activate amber lamps.
8. Do not tow the windrower on a roadway at night, or in conditions which reduce visibility, such as fog or rain. The width of the load makes it unsafe to transport under these conditions.
9. Be aware of roadside obstructions, oncoming traffic and bridges. Take care when travelling over rough terrain or on slopes.
10. **IMPORTANT:** Before towing, plug or cover muffler exhaust to prevent the turbine from turning without lubrication. This "free-wheeling" of the turbocharger can cause damage.



CASTER TRANSPORT LOCK

OPERATION

Storage Procedure

Do the following at the end of each operating season:



CAUTION:

- 1. Clean the windrower thoroughly. Never use gasoline, naphtha or any volatile material for cleaning purposes. These materials may be toxic and/or flammable.**
- 2. Store windrower in a dry protected place. Never operate engine in a closed building. Proper ventilation is required to avoid exhaust gas hazards.**
- 3. Remove the battery. Bring to full charge and store in a cool, dry place not subject to freezing. Remember when working around storage batteries that all of the exposed metal parts are "live". Never lay a metal object across the terminals because a spark and short circuit will result.**
- 4. Cover cutterbar and knife guards to prevent injury from accidental contact.**

Also:

5. If stored outside, always cover windrower with a waterproof tarpaulin or other protective material. This will protect the switches, instruments, tires, etc. from inclement weather. If no cover is available; seal air cleaner intake and exhaust pipe with plastic bags and/or waterproof tape.
6. If possible, block up windrower to take weight off tires. If it is not possible to block up the machine, increase tire pressure by 25% for storage. Adjust to recommended pressure before next use.
7. Repaint all worn or chipped painted surfaces to prevent rust.
8. Lubricate the windrower thoroughly, leaving excess grease on fittings to keep moisture out of bearings. Apply grease to exposed threads and sliding surfaces of components.
9. Check for worn components and repair. Tighten loose hardware and replace any missing hardware. See Specifications section for torque charts.
10. Check for broken components and order replacements from your dealer. Attention to these items right away will save time and effort at beginning of next season.
11. Add rust inhibitor to the engine oil.
Diesel Engine - use 10 oz (300 ml)
Run engine to operating temperature to mix inhibitor with oil.
12. To prevent condensation, fill hydraulic oil reservoir to filler neck with approved hydraulic system oil. See "Fuels, Fluids and Lubricants" in Maintenance/Service section.
13. Test engine coolant anti-freeze concentration to ensure it is sufficient to protect engine against lowest expected temperature.

MAINTENANCE/SERVICE

Service Procedures



CAUTION: To avoid personal injury, before servicing machine or opening drive covers:

1. Move variable speed lever to neutral and turn steering wheel until it locks to engage park brake.
2. Fully lower header and reel.
3. Disengage header drive clutch.
4. Stop engine and remove key.
5. Wait for all moving parts to stop.

Wear close-fitting clothing and cover long hair. Never wear dangling items such as scarves or bracelets.

Wear protective shoes with slip-resistant soles, a hard hat, protective glasses or goggles and heavy gloves.

Be prepared if an accident should occur. Know where the first aid kit and fire extinguisher are located and how to use them.

Keep the service area clean and dry. Wet or oily floors are slippery. Wet spots can be dangerous when working with electrical equipment. Be sure all electrical outlets and tools are properly grounded.

Use adequate light for the job at hand.

Park on level surface when possible. Block wheels securely.

Replace all shields removed or opened for service.

Use only service and repair parts made or approved by the equipment manufacturer. Substituted parts may not meet strength, design or safety requirements.

Keep the windrower clean. Do not allow oil or grease to accumulate on the service platform, ladder or controls.

Never use gasoline, naphtha or any volatile material for cleaning purposes. These materials may be toxic and/or flammable.



STAY CLEAR OF DRIVELINE
AND ALL MOVING PARTS

Welding Precautions



CAUTION: Avoid possible damage to the electronically controlled engine components. Before welding on any part of the machine, disconnect battery cables, alternator wire, main wiring harness (A) and connections to the ECM (B) located at rear of engine.

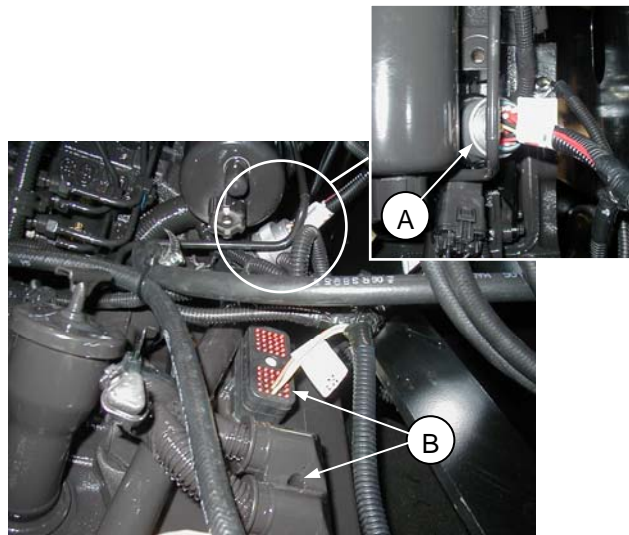

MAIN WIRING HARNESS

MAINTENANCE/SERVICE

Seat Belt Inspection and Maintenance

Keep the operator and trainer seat belts in good condition as follows:

1. Keep sharp edges and items that can cause damage away from the belts.
2. From time to time, check belts, buckles, retractors, tethers, slack take-up system and mounting bolts for damage.
3. Replace all parts that have damage or wear.
4. Replace belts that have cuts that can weaken the belt.
5. Check that bolts are tight on the seat bracket or mounting.
6. Keep seat belts clean and dry. Clean only with a soap solution and warm water. **DO NOT** use bleach or dye on the belts, as this may weaken the material.

R/H Step Ladder – Use & Storage

A storable ladder is provided on the right hand side of the tractor for access to the maintenance platform.

For storage, swing ladder up and pivot arm (A) down as shown.



Operator Presence System

Make sure the Operator Presence System is operating as follows:

1. With the windrower engine running, place the ground speed lever in neutral and turn the steering wheel until it locks.
2. With everyone clear of the machine, engage header drive switch.
3. After header drives are running, stand up out of the seat. In approximately 5 seconds the header should shut off. If not, the Operator presence system requires adjustment. See your dealer.

NOTE: To restart the header, the operator must move the header engage switch to "OFF" position and back to the "ON" position again.

MAINTENANCE/SERVICE

Fuels, Fluids and Lubricants

DIESEL FUEL

Use Grade No. 2 - D fuel, as defined by ASTM Designation: D 975 for diesel fuels.

NOTE: When temperature is very cold, the use of a mixture of No. 1 and No. 2 Diesel Fuel is permitted for a short period of time, providing the following specifications are met:

Sulphur Content - less than 1% by weight, preferably less than .5%.

Water and Sediment - for maximum filter life, should not exceed .1% by weight.

Cetane Number - 40 minimum. In cold weather or high-altitude operation, a higher cetane number (45 to 55) is desirable.

Diesel Fuel Conditioner is available from your dealer. The use of diesel fuel conditioner will:

1. Clean fuel injectors, valves and manifolds for increased service life.
2. Disperse insoluble gummy deposits that can form in the fuel system.
3. Separate moisture from the fuel.
4. Stabilize fuel in storage.

ENGINE COOLANT

Use a 50/50 mix of water and anti-freeze for protection to -30° F (-34° C).

Anti-freeze Specification: Ethylene-glycol or propylene-glycol fully formulated, containing a pre-charge supplemental coolant additive (SCA) and meeting ASTM Designation: D 4985.

GREASE

Use an SAE Multi-Purpose High Temperature Grease with Extreme Pressure (EP2) Performance and containing a maximum of 1% moly (molybdenum disulphide).

For driveline slip-joints only, increased moly content (up to 10%) is recommended. **IMPORTANT:** Do not use this higher moly content grease on bearings, as it may cause excessive wear in high speed applications.

HYDRAULIC OIL

For Australian Units Only – Use SAE 15W40 complying with SAE specs for API Class SJ and CH-4 engine oil.

For All other Units – Use single grade trans-hydraulic oil.

The following oil company and equipment

manufacturer brand names are **recommended:**

Petro Canada Duratran

Case IH Hy-Tran Plus®

John Deere Quatro® J20C

Agco Power Fluid 821XL

The following oil company and equipment
manufacturer brand names are acceptable:

New Holland Hydraul

Esso/Exxon Hydraul 56

Shell Donax TD

MAINTENANCE/SERVICE

Fuels, Fluids and Lubricants (continued)

ENGINE OIL

SAE 15W40 complying with SAE specs for API Class SJ and CH-4 engine oil minimum. High grade oil would be API CI-4SK or API CI-4.

POWER HUB GEAR LUBRICANT & BEVEL GEAR BOX LUBRICANT

Use ISO VG220 synthetic gear lubricant. The following oil company brand names are recommended:

Petro Canada: Traxon E Synthetic 75W-90
Esso/Exxon: SPARTAN Synthetic 220 EP
Shell: OMALA HD 220
Mobil: Mobilube SHC 75W-90
Texaco: Pinnacle 220 EP Synthetic Gear Lubricant
Chevron: Tegra Synthetic Gear Lubricant ISO 220

STORING LUBRICANTS

IMPORTANT: Your machine can operate at top efficiency only if clean lubricants are used. Use clean containers to handle all lubricants. Store them in an area protected from dust, moisture and other contaminants.

SYSTEM CAPACITIES

	<u>S.I.</u>	<u>U.S.</u>
Fuel Tank	284 L	75 gal.
Hydraulic System: Total (varies with options) Reservoir Capacity	65 L (approx.) 57 L	17 gal. (approx.) 15.2 gal.
Bevel Gear Box	1.6 L	1.7 qt.
Power Hubs	1800 mL	60 oz.
Engine Cooling System: Diesel	18 L	4.8 gal.
Diesel Engine Crankcase: Less Filter With Filter	9.5 L 10.4 L	10 qts. 11 qts.
Air Conditioning System: Refrigerant (R134a) Oil (SP-15 PAG)	1.36 kg 240 cc*	3 lbs. 8.1 fl.oz.*

* - This amount of oil is the full system requirement and is included in a new compressor.

MAINTENANCE/SERVICE

Greasing the Windrower Tractor

See "Fuels, Fluids and Lubricants" for recommended greases.

The following greasing points are marked on the windrower by decals showing a grease gun (A), and grease interval (B) in hours of operation. Use the engine hour meter in the cab and the "Maintenance Checklist" provided to keep a record of scheduled maintenance.

Procedure:

1. Wipe grease fitting with a clean cloth before greasing, to avoid injecting dirt and grit.
2. Inject grease through fitting with grease gun until grease overflows. Inject grease slowly to prevent seal damage.
3. Leave excess grease on fitting to keep out dirt.
4. Replace any loose or broken fittings immediately.
5. If fitting will not take grease, remove and clean thoroughly. Also clean lubricant passageway. Replace fitting if necessary.
6. Store grease gun on tractor frame at (C).



DANGER: Stay clear of drivelines until all movement has stopped. Entanglement with rotating driveline will cause serious personal injury or death. Avoid loose fitting or dangling clothing.

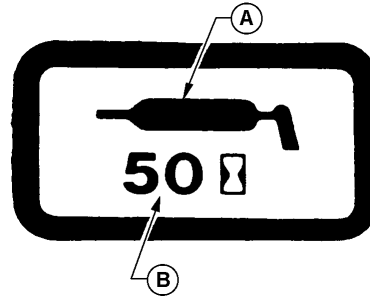

SAMPLE GREASE DECAL

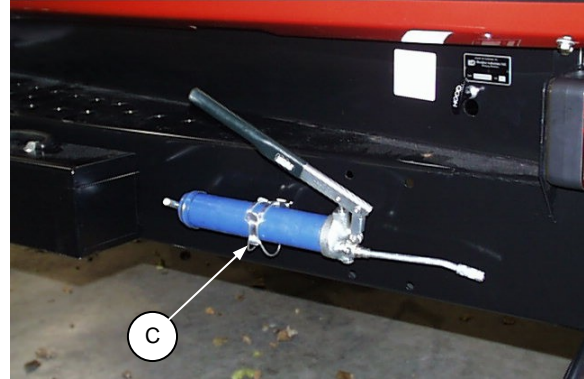

GREASE GUN STORAGE

10 Hours

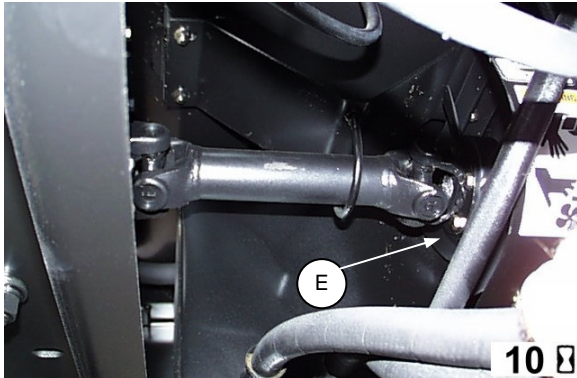

TRANSMISSION DRIVELINE SLIP JOINT (E) - ONE FITTING

50 Hours

NOTE: For Harvest Header, there are two more 10 Hour fittings on driveline connector shaft.



STAY CLEAR OF ROTATING DRIVELINES

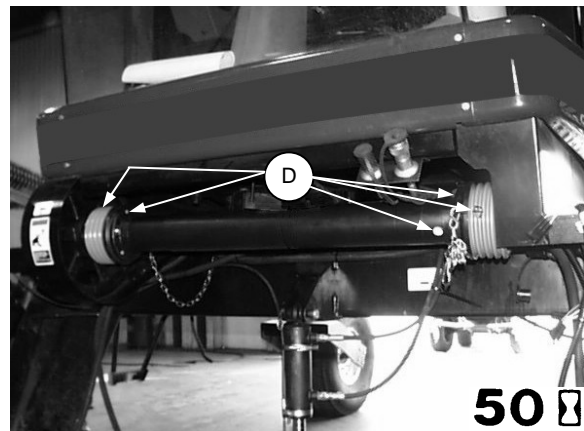

DRIVELINE (D) - FIVE FITTINGS (2 CROSSES, 1 SHAFT, 2 SHIELD)

MAINTENANCE/SERVICE

Greasing the Windrower Tractor: 50 Hours (continued)

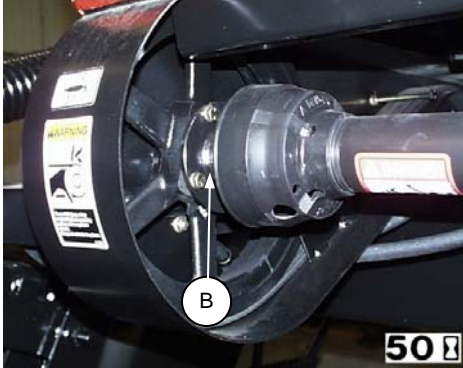

HEADER DRIVE PULLEY (B) - ONE FITTING

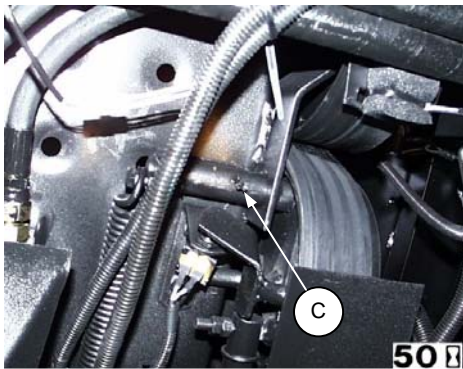

HEADER CLUTCH PIVOT (C) - ONE FITTING

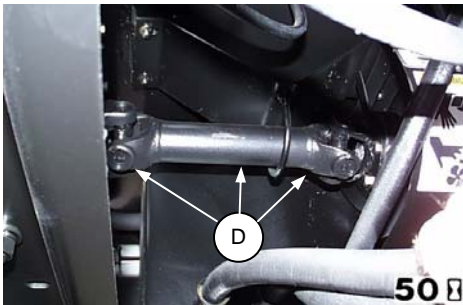

TRANSMISSION DRIVELINE U-JOINTS (D)
THREE FITTINGS

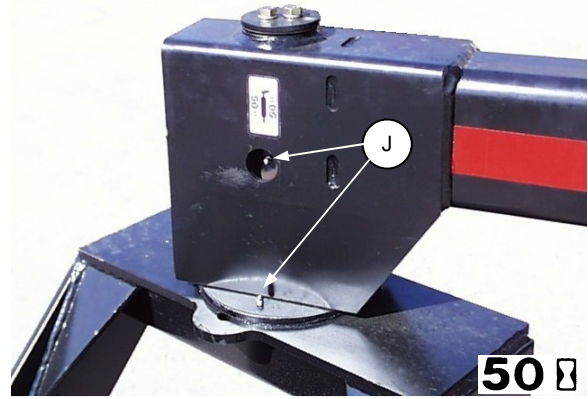

CASTER PIVOTS: (J) – FOUR FITTINGS
IMPORTANT: Pump until grease pushes out top of caster



WALKING BEAM PIVOT (E) - ONE FITTING

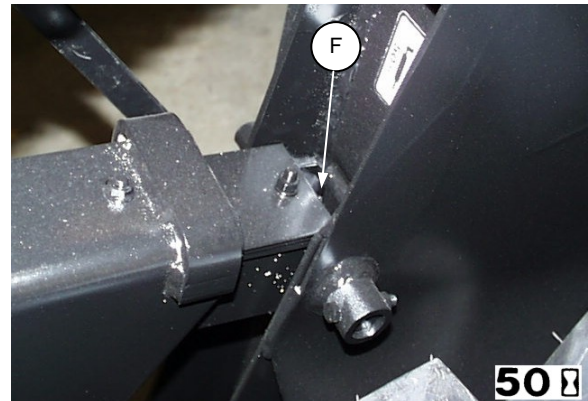

TOP LIFT LINK REAR PIVOT (F) - TWO FITTINGS

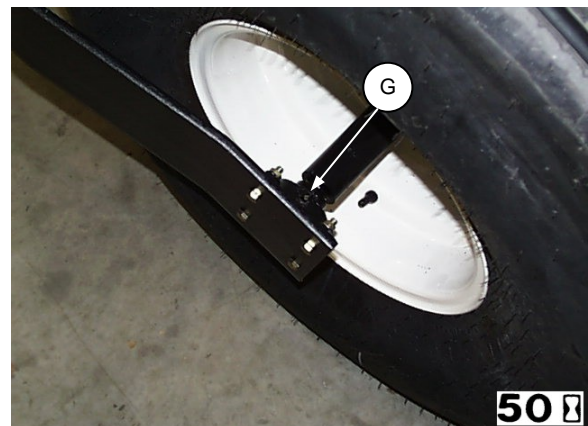

FORKED CASTER SPINDLE BEARINGS (G)
FOUR FITTINGS (16.5 & 11-16 TIRES ONLY)

MAINTENANCE/SERVICE

Greasing the Windrower Tractor: 200 Hours or Annually



CASTER WHEEL HUB BEARINGS (H)
TWO FITTINGS

MAINTENANCE/SERVICE

Engine



CAUTION: Never operate engine in a closed building. Proper ventilation is required to avoid exhaust gas hazards.

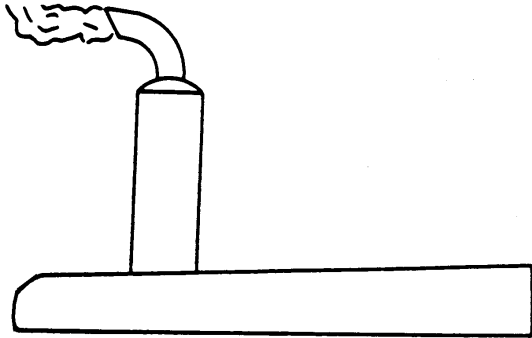

AVOID EXHAUST GAS HAZARDS

Keep the engine clean. Straw and chaff on a hot engine are a fire hazard.

Never use gasoline, naphtha or any other volatile material for cleaning purposes. These materials may be toxic and/or flammable.

CUMMINS BARRING TOOL

Hole (A) is provided in left front engine mount for use of a Cummins barring tool to manually turn flywheel.



BARRING TOOL ACCESS HOLE

OPENING & CLOSING HOOD

For access to the engine compartment:

1. Pull hood release handle (B).
2. Lift hood to raised position.

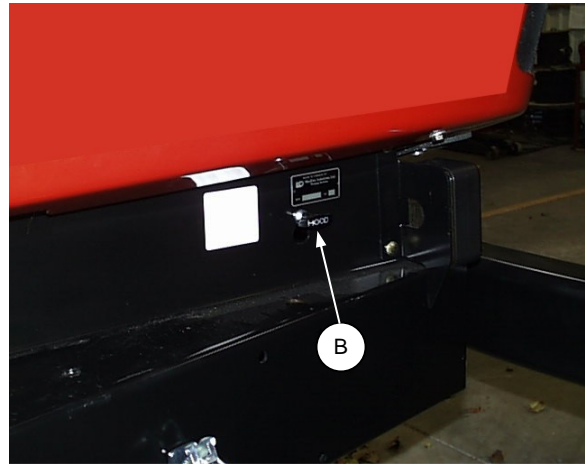

HOOD RELEASE HANDLE

To close:

3. Grasp panel at interior hand-hold (C).
4. Lower panel to closed position, ensuring latch engages.



CLOSING HOOD

NOTE: A pull rope is provided to ease closing. Release rope from storage bracket at (D) and pull down.

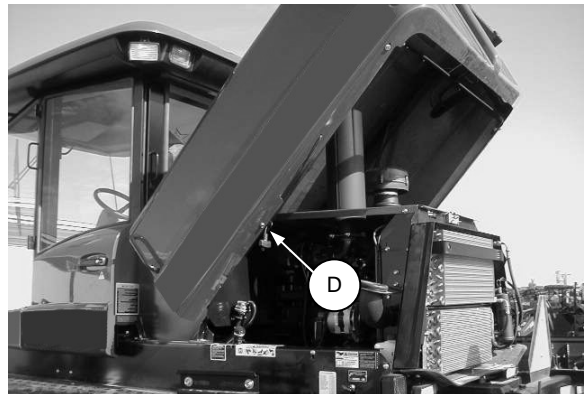

MAINTENANCE/SERVICE

Diesel Engine

LUBRICATING OIL

Check engine oil level daily on dipstick.

See "Fuels, Fluids and Lubricants" section for recommended oil type.

IMPORTANT: Never operate the engine with the oil level below the "L" (LOW) mark or above the "H" (HIGH) mark.

CAPACITY - LOW MARK TO HIGH: 2 U.S. qt. (2 litres)

Change engine oil and filter after the FIRST 50 HOURS OF OPERATION and every 500 hours (or beginning of each operating season) thereafter.

To change:

1. Warm up the engine. Shut engine off and remove ignition key.
2. Remove the drain plug (A) and allow oil to drain.



CAUTION: Remember that the oil is hot.

NOTE: A drain pan with a capacity of 5 U.S. gallons (20 litres) will be adequate.

3. Check the condition of the used oil:
 - Thin, black oil indicates fuel dilution.
 - Milky discoloration indicates coolant dilution.

If oil appears diluted, have your Dealer correct the problem before operating the windrower.

4. Clean around the filter head, remove the filter (F) and clean the gasket surface.
5. Apply a thin film of clean oil to the gasket on the new filter.

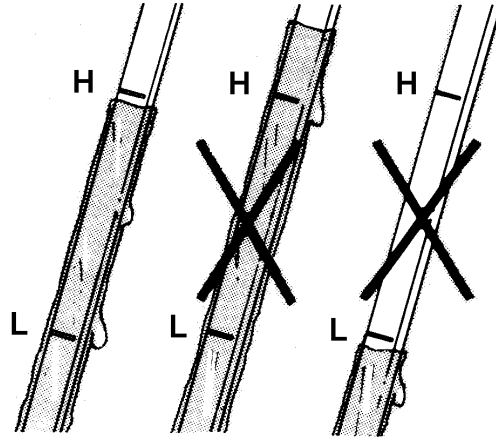

MAINTAIN ENGINE OIL LEVEL

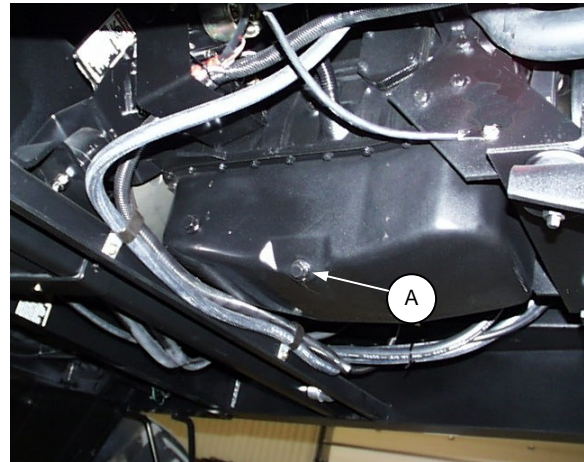

REMOVE DRAIN PLUG

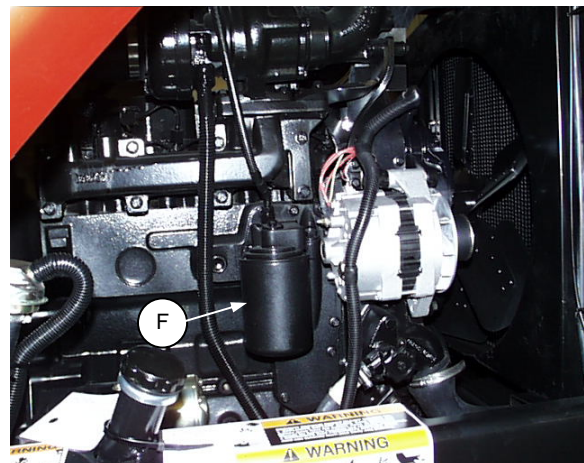

OIL FILTER

MAINTENANCE/SERVICE

Diesel Engine

LUBRICATING OIL

Changing engine oil and filter (continued)

6. Install the new filter. Turn the filter onto the mount until the gasket contacts the filter head. Tighten the filter an additional 1/2 to 3/4 turn by hand.

IMPORTANT: Do not use a filter wrench to install the oil filter. Over-tightening can damage the gasket and the filter.

7. Install the oil pan drain plug.

8. Fill the engine at (A) with the proper amount of oil. See "Fuels, Fluids and Lubricants" section for recommended oil types.

<u>Capacity</u>	<u>Diesel Engine</u>
With filter change	11 US qts (10.4L)
Without filter change	10 US qts (9.5L)

9. Operate the engine at low idle and check for leaks at the filter and drain plug.

10. Shut off engine. Wait five minutes, then check oil level at dipstick. If required, add or drain oil to bring level to high mark.

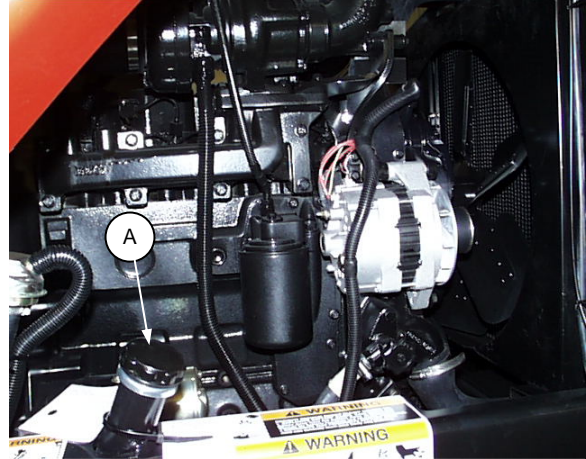

OIL FILLER LOCATION
(view from right side of window)

DIESEL ENGINE BELTS

The alternator/water pump/fan belt is automatically tightened. No manual adjustment is required. See installation procedure at right.

NOTE: When installing new compressor belt (G), never pry belt over pulley. Loosen necessary hardware and adjust belt tension. Re-adjust tension of a new belt after a short run-in period. (About 5 hours.)

To adjust compressor belt:

1. Loosen compressor mounting hardware.
2. Adjust tension so that a force of 8 to 12 lbs. (35 to 55 N) deflects belt 3/16 inch (5 mm) at mid-span.
3. Tighten compressor mounting hardware and recheck tension.

- A - Air Conditioning Compressor
- B - Alternator
- C - Water Pump
- D - Fan Pulley
- E - Crankshaft Pulley
- F - Automatic Belt Tightener
- G - Compressor Belt
- H - Alternator/Water Pump/Fan Belt

NOTE: For easiest installation of new belt (H): Install around pulleys (E), (D), and (B), then raise tensioner (F) and install on pulley (C). Lower tensioner and check belt is properly seated in all pulley grooves.

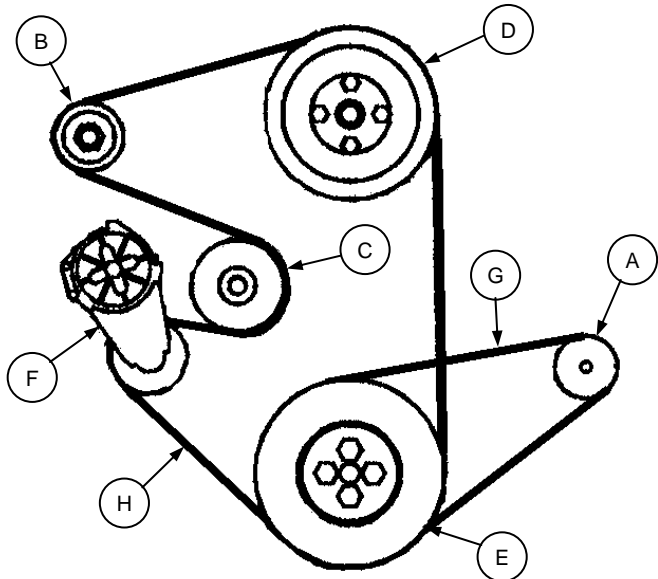

BELTS - DIESEL ENGINE

MAINTENANCE/SERVICE

Diesel Engine

ENGINE SPEED:

Turbocharged units have an electronic throttle. No adjustment required.

Engine maximum and low idle speeds are factory set to specifications listed on page 13.

IMPORTANT: Do not remove any seals from injector pump; removal of seals will void engine warranty. If specified speeds can not be maintained, see your Windrower dealer.

NOTE: In addition to in-cab tachometer, hand held tach can be attached at bevel gear box output shaft. For access to end of shaft, remove cover (D) on right side of tractor frame.

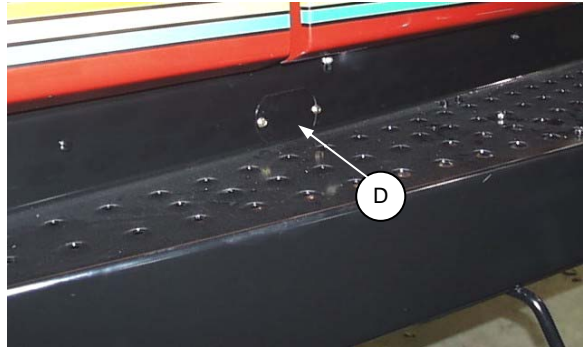

ACCESS TO GEARBOX SHAFT
FOR TACHOMETER

VALVE TAPPET CLEARANCE

Every 1000 hours of operation, have diesel engine valve tappet clearance checked and adjusted by your Windrower dealer.

GENERAL ENGINE INSPECTION

Every 2000 hours of operation, see your Windrower dealer for required general service or tune-up.

For diesel engine, have fuel injection pump and nozzles inspected at this time.

MAINTENANCE/SERVICE

Diesel Engine: Air Intake System

AIR CLEANER

IMPORTANT: Do not run engine with air cleaner disconnected or disassembled.

The air cleaner is equipped with a vacuator valve which removes dust continuously from the air cleaner housing.

Check daily that system is functioning properly:

1. Remove air cleaner end cap (A).
2. Check for dust inside the canister.
3. If dust or debris is present, clean canister and check for the source of the contamination. Possibilities are:
 - a. Obstruction in vacuator valve (B). Clean or replace if necessary.
 - b. Loose connection at any air-intake hose clamp. Tighten hose clamp.
4. Reinstall air cleaner end cap.

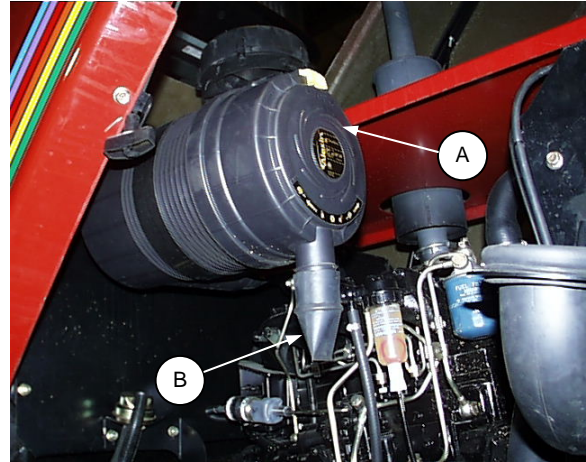

AIR CLEANER

FILTER ELEMENTS - CLEANING AND INSPECTION

The diesel engine air cleaner is equipped with a restriction gauge (A) which signals red when the primary filter element requires cleaning. Check restriction gauge daily. Never clean filter element unless restriction gauge signals red. Excessive cleaning will shorten element life. After cleaning, re-set restriction gauge by pushing button on top of gauge.

IMPORTANT: The air cleaner is a dual element type. Clean the primary (outer) element only. Do not attempt to clean the secondary (inner) element. If there is visible dirt on the secondary element, replace both primary and secondary elements. See "Filter Elements - Replacement" for normal change interval.

To clean air filter element:

1. Remove element from air cleaner canister.
2. Clean inside of canister and cover with a damp cloth.
3. Inspect element as follows:
 - Hold a bright light (B) inside element and check carefully for holes. Discard any element which shows the slightest hole.
 - Be sure outer screen (C) is not dented. Vibration would quickly wear a hole in the filter.
 - Be sure filter gasket (D) is in good condition. If gasket is damaged or missing, replace element.
4. Pat sides of element gently to loosen dirt. Do not tap element against a hard surface.

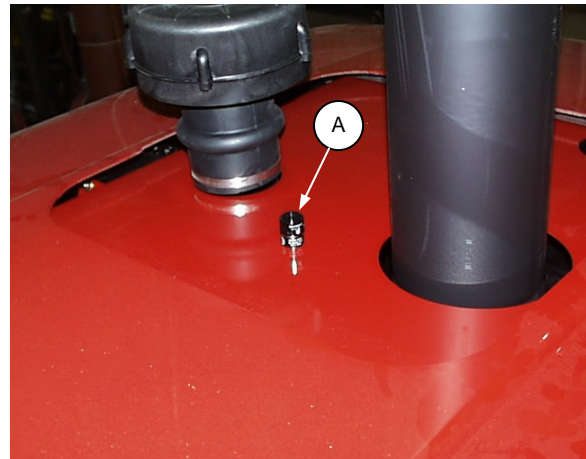

RESTRICTION GAUGE

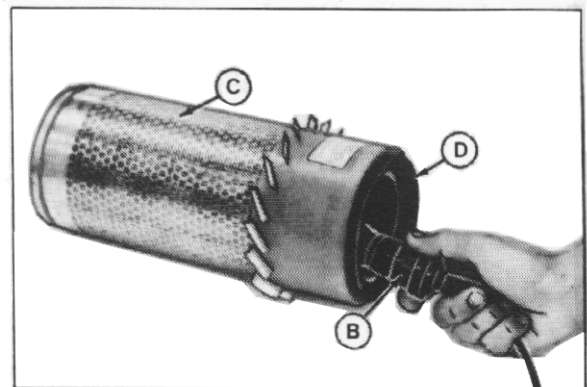

INSPECT ELEMENT

MAINTENANCE/SERVICE

Diesel Engine: Air Intake System

AIR CLEANER

CLEANING FILTER ELEMENTS (continued)

- Using a Dry Element Cleaner Gun, clean element with compressed air.

Hold nozzle next to inner surface, and move up and down pleats.

IMPORTANT: Air pressure must not exceed 100 psi (700 kPa). Do not direct air against outside of element, as dirt might be forced through to inside.

- Repeat steps 4 and 5 to remove additional dirt.
- If washing is not necessary, repeat inspection (Step 3) before installing.

- If element is coated with oil or soot, wash in a solution of warm water and Filter Element Cleaner (Donaldson D1400 or equivalent) as follows:

-Let element soak in solution at least 15 minutes, then agitate gently to flush out dirt.

-Rinse element thoroughly from inside with clean water. Use element cleaning gun or a free-running hose (maximum pressure 40 psi [275 kPa]; higher pressures can damage element).

-Allow element to dry completely before using. This usually takes from one to three days. Do not oven dry, or use compressed air or other drying agents. Protect element from freezing until dry.

-Inspect element (Step 3) before re-installing.

- Inspect the air intake piping for damage, cracked hoses, loose clamps, etc.

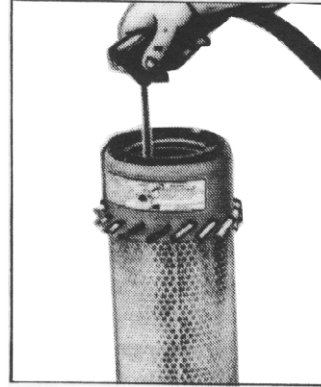

CLEAN WITH COMPRESSED AIR

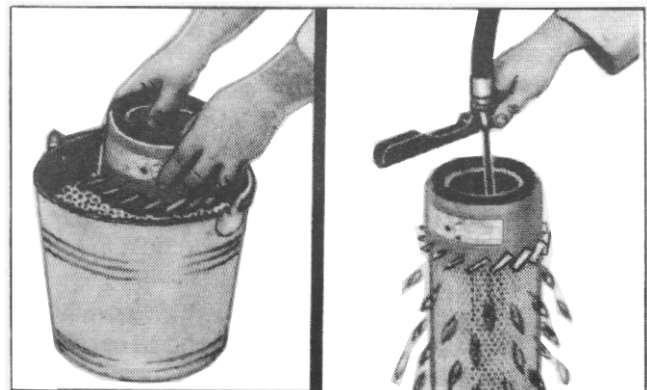

WASH AND RINSE ELEMENT

FILTER ELEMENTS - REPLACEMENT

The air cleaner's primary (outer) filter element should be replaced after six cleanings or at least every three years.

The secondary (inner) element must not be cleaned, and should be replaced every third time the primary element is changed.

MAINTENANCE/SERVICE

Diesel Engine: Fuel System

STORING FUEL

- Buy good quality, clean fuel from a reputable dealer.
- Proper fuel storage is critically important. Keep all dirt, water and other contaminants away from fuel.
- Avoid storing fuel over long periods of time. If you have a slow turnover of fuel in windrower tank or supply tank, add fuel conditioner to avoid condensation problems.
- Store fuel in a convenient place away from buildings.

REFUELLING WINDROWER



WARNING: To avoid personal injury or death from explosion or fire, do not smoke or allow flame or sparks near fuel tank when refuelling.

Never refuel the windrower when the engine is hot or running.

IMPORTANT: Do not fill tank completely; space is required for expansion. A filled tank could overflow if exposed to a rise in temperature, such as direct sunlight.

Fill fuel tank daily, preferably at the end of the day's operation. This prevents condensation in the tank as moist air cools overnight.

See "Fuels, Fluids and Lubricants" for recommended fuels.

IMPORTANT: Do not allow tank to empty. Running out of fuel can cause air locks and/or contamination of the fuel system. See "Fuel System Air Removal" in this section.

TANK CAPACITY is 75 U.S. gallons (284 litres).



REFUEL SAFELY

FUEL TANK VENTING

If fuel tank cap requires replacement, be sure to order the original equipment part, which is NOT vented.

The fuel tank is vented by hose (A), which is connected to filler tube. Change filter (B) at end of vent hose annually.

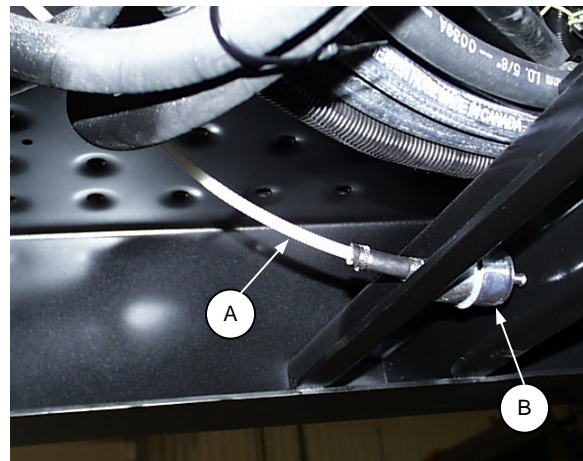

FUEL TANK VENT HOSE

MAINTENANCE/SERVICE

Diesel Engine: Fuel System

FUEL SEDIMENT BOWL

Inspect fuel sediment bowl daily for water or other contaminants. Bowl is located under tank. Clean as required.

To clean:

1. Close valve (A) to shut off fuel.
2. Loosen nut (B) and remove bowl.
3. Clean bowl and mesh screen in head.
4. Replace bowl and open valve (A).

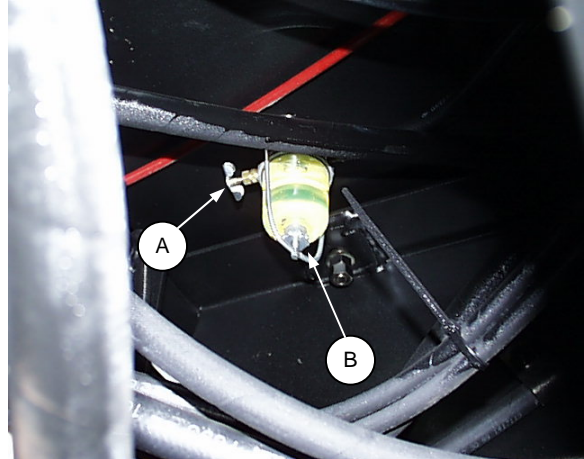

FUEL SEDIMENT BOWL

FUEL/WATER SEPARATOR

Drain the water and sediment from the separator at the fuel filter daily, as follows:

1. Shut off engine.
2. Open the drain valve (A) by hand, 1½ to 2 turns counter-clockwise until draining occurs.
3. Drain the filter sump of water until clear fuel is visible.
4. **IMPORTANT:** Do not over-tighten valve. Damage to threads may result.

Turn the valve clockwise to close the drain valve.

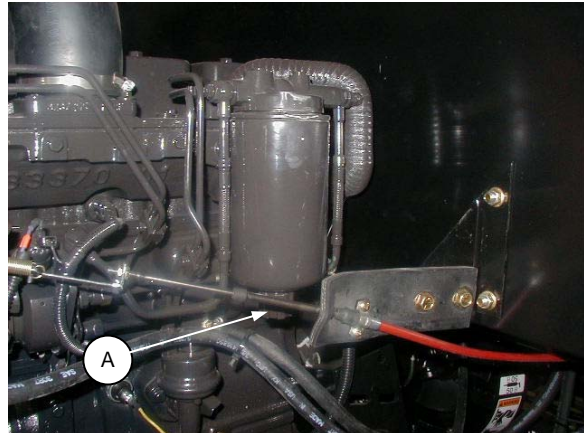

FUEL/WATER SEPARATOR
(Naturally Aspirated Tractor Shown)

MAINTENANCE/SERVICE

Diesel Engine: Fuel System FUEL FILTERS - DIESEL ENGINE

Change fuel filters every 500 hours of operation.
NOTE: 2004 and earlier models have two fuel filters, 2005 units have only one.

To change:

1. Close valve (A) under fuel tank to shut off fuel.

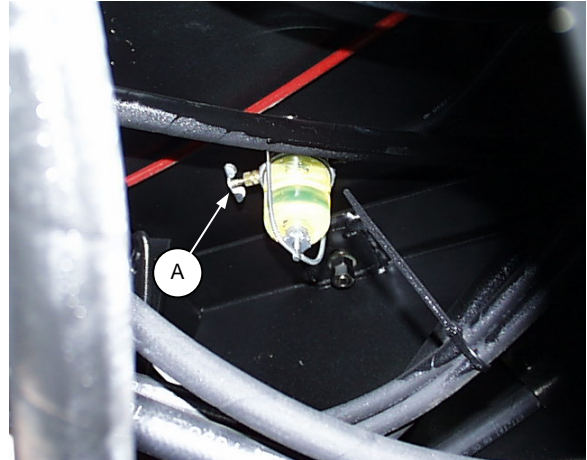

FUEL SHUT-OFF VALVE

2. Clean the filter head, filter (B) and the engine area next to the filters.

3. Remove the filter using a filter wrench.

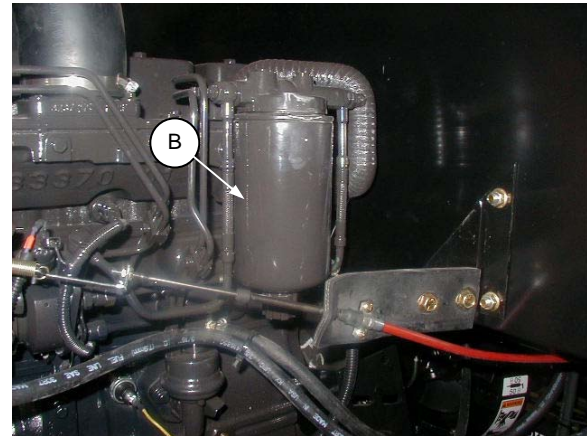

REMOVE FILTER
(Naturally Aspirated Tractor Shown)

4. **IMPORTANT:** Fill the new filter with clean fuel and apply a thin film of clean oil to the filter gasket.

5. Install the new filter. Turn the filter onto the mount until the gasket contacts the filter head. Tighten the filter an additional 1/2 turn to 3/4 turn by hand.

IMPORTANT: Do not use a filter wrench to install filter. Over-tightening can damage the gasket and filter.

6. Open valve (A) under tank.

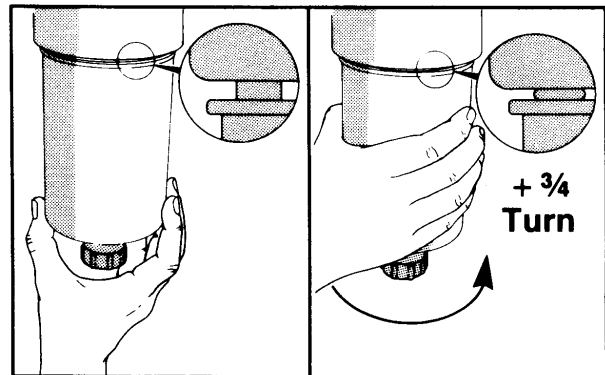

INSTALL FILTER

MAINTENANCE/SERVICE

Diesel Engine: Fuel System

FUEL SYSTEM AIR REMOVAL - DIESEL ENGINE

Controlled venting of air is provided at the injection pump through the fuel drain manifold. Small amounts of air introduced by changing filters or injection pump supply line will be vented automatically, if the fuel filter is changed in accordance with instructions. (See "Fuel Filters".) However, manual venting ("bleeding") may be required if:

1. The fuel filter is not filled prior to installation.
2. Injection pump is replaced.
3. High-pressure fuel lines are replaced.
4. Engine is run until fuel tank is empty.

To bleed LOW pressure lines and fuel filters:

1. Loosen the bleed screw (A) located at the outlet fitting from the fuel filter housing.
2. Push plunger (B) on the lift pump until clear fuel with no air bubbles flows from around the bleed screw.
3. Tighten the bleed screw (A).

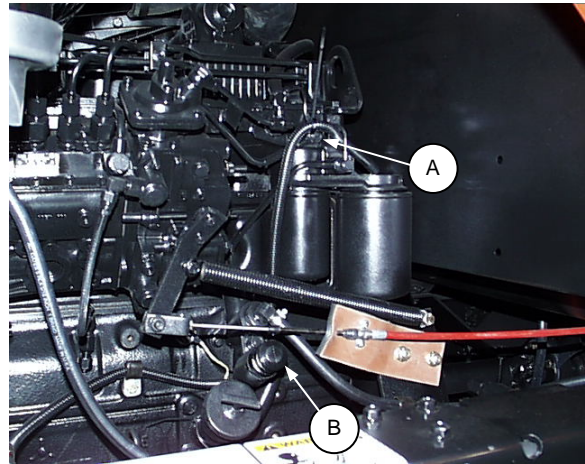

BLEEDING LOW PRESSURE LINES
AND FILTERS – TURBO
(Throttle linkage not present on XX52 model)

MAINTENANCE/SERVICE

Diesel Engine: Fuel System

FUEL SYSTEM AIR REMOVAL - DIESEL ENGINE (continued)

To bleed high pressure lines:



WARNING: Escaping fluid under pressure can penetrate the skin causing serious injury. When disconnecting diesel lines, have engine stopped and loosen fittings slowly to relieve pressure. Tighten all connections before applying pressure. Keep hands and body away from pin-holes and nozzles which eject fluids under high pressure. Use a piece of cardboard or paper to search for leaks. Do not use your hand.

If ANY fluid is injected into the skin, it must be surgically removed within a few hours by a doctor familiar with this type of injury or gangrene could result.



WARNING: Do not bleed a hot engine as this could cause fuel to spill onto a hot exhaust manifold creating a danger of fire.



WARNING: It is necessary to have the engine cranking for this procedure. Two persons will be required; one to turn ignition switch and one to watch the injector connections.

Use extreme care when working around moving parts. Wear close fitting clothing and protective eye-wear. Keep hands, feet, clothing and hair away from moving parts.

1. With engine stopped, slowly loosen fittings at the injectors as shown.
2. Turn key in ignition switch fully clockwise to START position and crank for 15 seconds maximum. Allow starter to cool for two minutes before cranking again.
3. When clear fuel with no air bubbles flows from the connections, stop cranking the engine and tighten fittings.

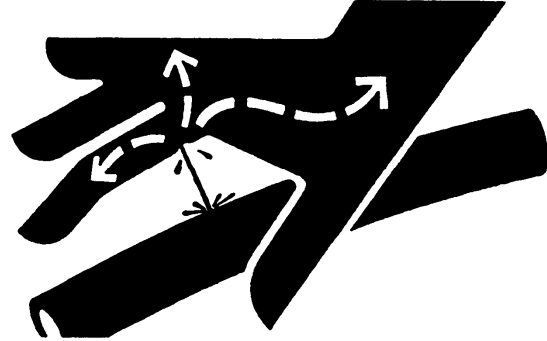

AVOID PRESSURIZED FLUID

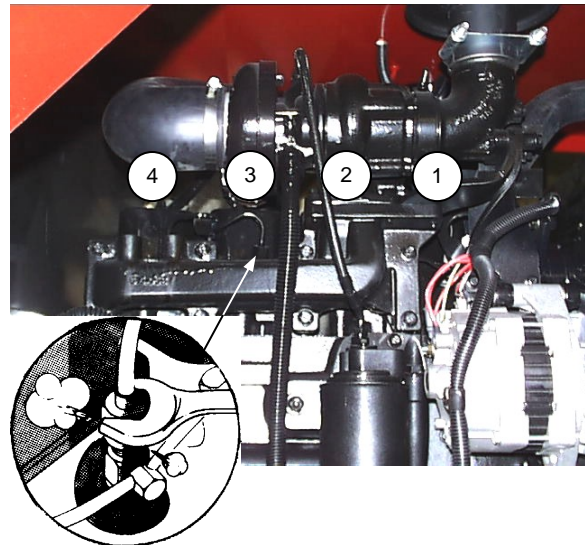

BLEEDING HIGH PRESSURE LINES

Engine Exhaust System

MUFFLER



CAUTION: To avoid burns, do not touch muffler when engine is running or before allowing sufficient cooling time after shut-down.

MAINTENANCE/SERVICE

Engine Cooling System

COOLANT LEVEL

Check coolant level daily at reserve tank (A). Check level when engine is cold.

If tank is less than half full, add coolant to reserve tank (A), not to radiator.

IMPORTANT: Use a 50/50 mix of clean, soft water and anti-freeze. This ratio will protect engine to temperatures of -30°F (-34°C). Anti-freeze Specification: Ethylene-glycol or propylene-glycol fully formulated, containing a pre-charge supplemental coolant additive (SCA) and meeting ASTM Designation: D 4985.

Anti-freeze is essential in any climate. It broadens the operating temperature range by lowering the coolant freezing point and by raising its boiling point. Anti-freeze also contains rust inhibitors and other additives to prolong engine life.

IMPORTANT: If anti-freeze strength is not adequate, do not drain cooling system to protect against freezing. System may not drain completely, and damage from freezing could still result.

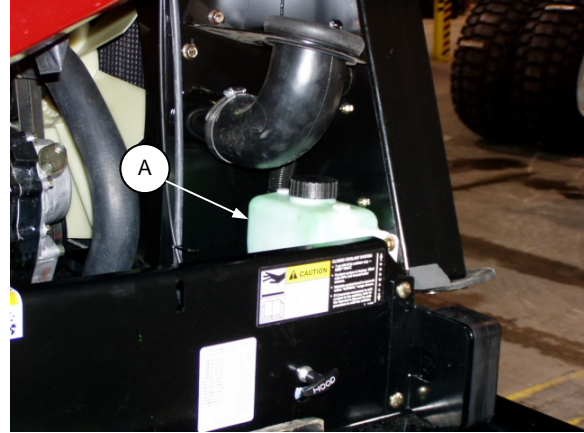

MAINTAIN COOLANT LEVEL

RADIATOR CAP

The radiator cap must fit tightly and the cap gasket must be in good condition to maintain the 7 psi (58 kPa) pressure in the cooling system.



CAUTION: To avoid personal injury from hot coolant, do not turn radiator cap until engine has cooled.

Turn the cap to the first notch to relieve pressure before removing cap completely. If it becomes necessary to add coolant to the radiator, use a ladder as shown.



USE LADDER TO ACCESS RADIATOR

ANTI-FREEZE CONCENTRATION

Check the anti-freeze concentration with a tester once per season, preferably before off-season storage. Protect the engine to -30°F (-34°C) with a 50/50 anti-freeze and water mixture.

MAINTENANCE/SERVICE

Engine Cooling System

CHANGING COOLANT

Coolant should be removed, and the system flushed and filled with new coolant every 2000 hours or 2 years.

Procedure:



CAUTION: To avoid personal injury from hot coolant, do not turn radiator cap until engine cools. Turn the cap to the first notch to relieve pressure before removing cap completely. Use a ladder as shown on previous page to access radiator.

1. With engine cool and approximately level, remove radiator cap.

NOTE: A drain pan with a capacity of 8 U.S. gallons (30 litres) will be adequate.

2. Remove drain plug (B) from engine block.

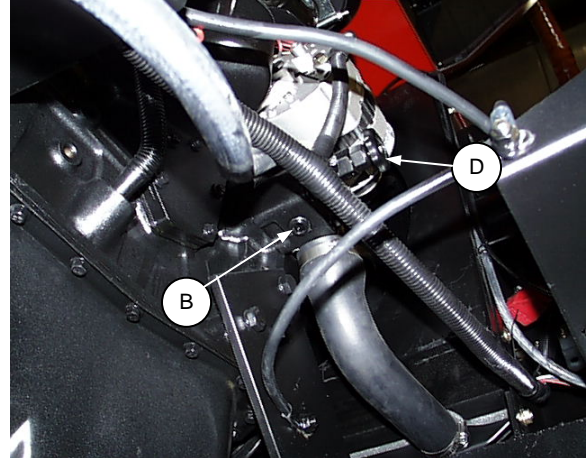

BLOCK DRAIN & HEATER VALVE

3. Open radiator drain valve (C). Use a deflector to prevent coolant running onto frame.

4. When system is drained, replace drain plug in block and close radiator drain valve.

5. Fill system with clean water and replace radiator cap.

6. Open heater valve (D) at water pump. Turn heater switch in cab ON and leave it on until flushing is complete.

7. Start and run engine until normal operating temperature is reached.

8. Stop engine and drain water out before rust or sediment settles.

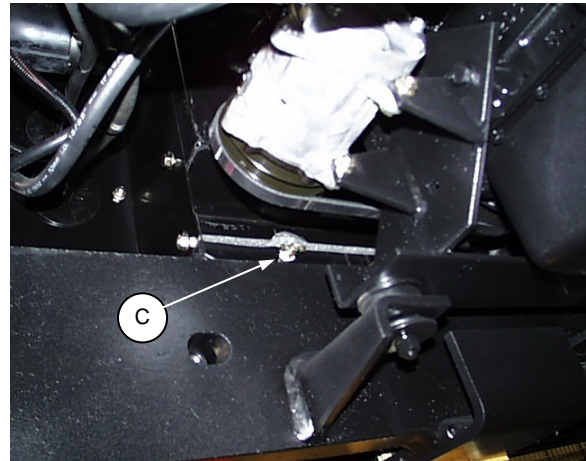

RADIATOR DRAIN

9. Close drain valves and fill system with a solution of clean water and a heavy duty radiator cleaner. Follow instructions provided with cleaner.

10. After using cleaner solution, again flush system with clean water. Inspect radiator, hoses and fittings for leaks.

11. Close drain valves and fill system through radiator with a 50/50 mix of anti-freeze and clean, soft water.

SYSTEM CAPACITY - 4.8 U.S. gallons (18 litres)

Anti-freeze Specification: Ethylene-glycol or propylene-glycol fully formulated, containing a pre-charge supplemental coolant additive (SCA) and meeting ASTM Designation: D 4985.

12. Close radiator cap tightly.

13. Fill reserve tank half full.

MAINTENANCE/SERVICE

Engine Cooling System

SCREENS AND COOLERS

RADIATOR SCREEN

The radiator screen may be equipped with an automatic cleaning device which "vacuums" the screen by means of two rotors (A).

If rotors fail to clean the screen adequately, remove plastic arm and check for obstructions in ducting from screen to fan shroud.

For units not equipped with cleaning device, manually clean the screen periodically during a day's operation. Do not allow excessive trash build-up.

NOTE: The rotary cleaning device may be ordered as an attachment.

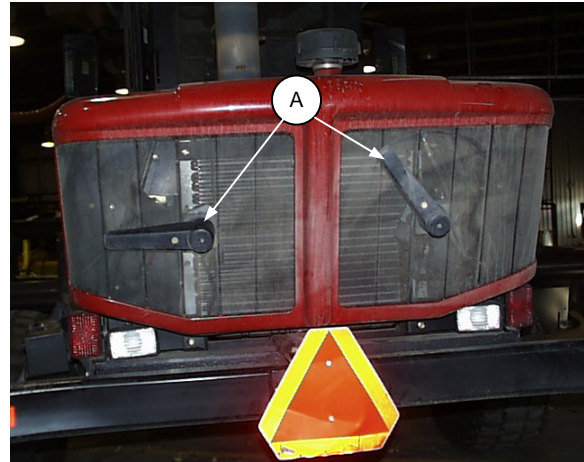

RADIATOR SCREEN

RADIATOR (C), OIL COOLER (D) and CONDENSER (E) - Should be cleaned daily with compressed air. More frequent cleaning may be necessary in severe conditions.

For access to oil cooler and condenser, open engine compartment hood.

For access to radiator, loosen wing nut (F), pivot retainer and swing cooler and condenser mount out.

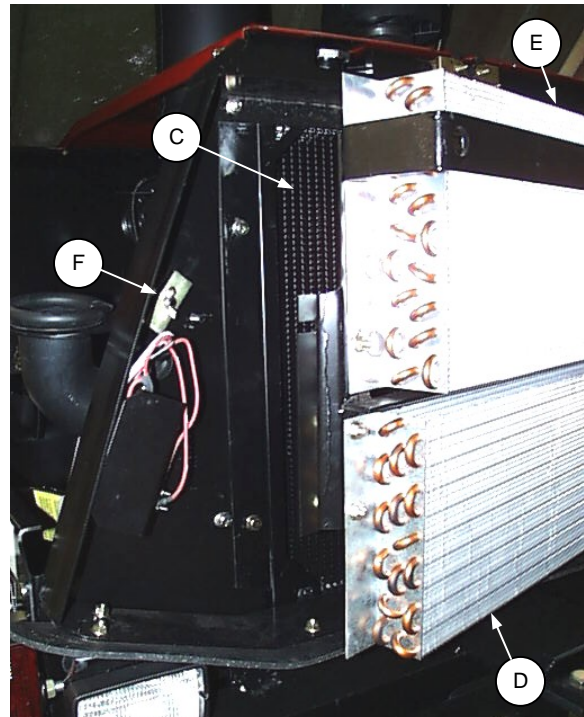

RADIATOR, OIL COOLER AND CONDENSER

MAINTENANCE/SERVICE

Electrical System

BATTERY



WARNING:

- Gas given off by battery electrolyte is explosive. Keep all smoking materials, sparks and flames away from batteries.
- Follow proper charging and boosting procedures given in this section.
- Ventilate when charging in enclosed space.
- Always wear protective eye-wear when working near batteries.
- Do not tip batteries more than 45° to avoid electrolyte loss.
- Battery electrolyte causes severe burns. Avoid contact with skin, eyes or clothing.
- Keep batteries out of reach of children.
- If electrolyte is spilled or splashed on clothing or the body, neutralize it immediately with a solution of baking soda and water, then rinse with clean water.
- Electrolyte splashed into the eyes is extremely dangerous. Should this occur, force the eye open and flood with cool, clean water for five minutes. Call a doctor immediately.
- To avoid shocks, burns or damage to electrical system, disconnect battery ground cable before working in an area where you might accidentally contact electrical components.

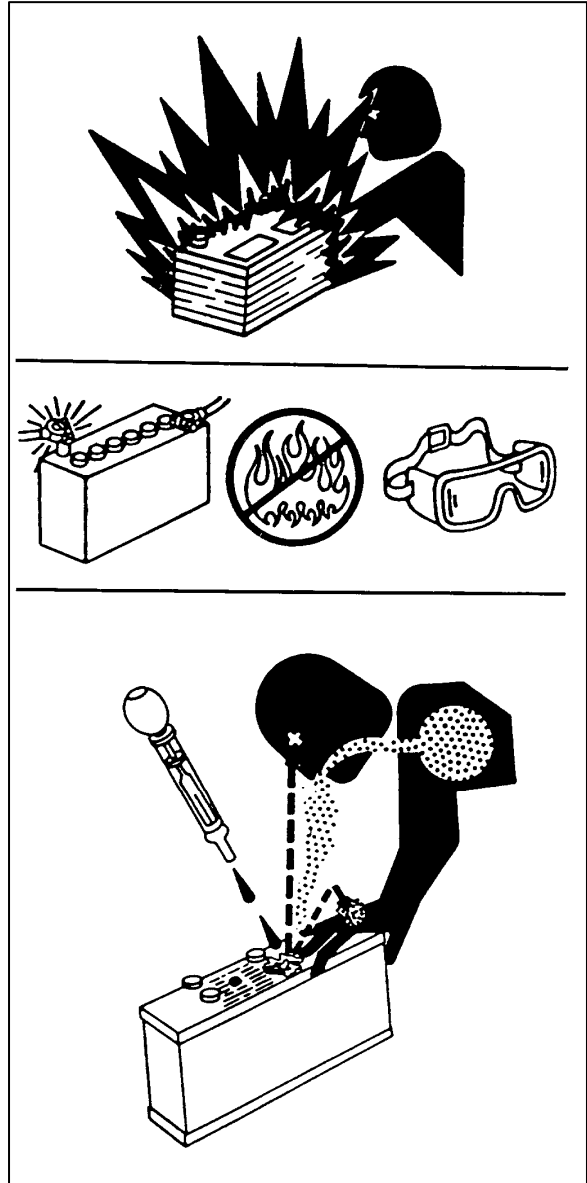

BE CAREFUL AROUND BATTERIES

NOTE: For easier battery installation or removal, position a low platform on which to stand when lowering or lifting battery.

MAINTENANCE/SERVICE

Electrical System

BATTERY (continued)

PREVENTING BATTERY DAMAGE

1. Be sure alternator connections are correct before cables are connected to battery. See "Preventing Alternator and Regulator Damage" in this section.
2. Carefully observe polarity when attaching booster battery.
3. Do not operate the engine with alternator or battery disconnected.



WARNING: With battery cables disconnected and engine running, a high voltage can be built up if terminals touch the frame. Anyone touching the frame under these conditions would be severely shocked.

4. Do not short across battery or alternator terminals, or allow battery positive (+) cable or alternator wire to become grounded.
5. Do not polarize the alternator.
6. Before welding on any part of the machine, disconnect battery cables, alternator wire and main wiring harness located at rear of engine.
7. To prolong battery life, store batteries fully charged and at +20° to +80°F (-7° to +26°C). Check voltage after storage and recharge as needed, according to battery and charger manufacturer recommendations.
8. Do not stack storage batteries on top of each other.



CAUTION: When working around storage batteries, remember that all of the exposed metal parts are "live". Never lay a metal object across the terminals because a spark or short circuit will result.

BATTERY MAINTENANCE



CAUTION: Do not attempt to service battery unless you have the proper equipment and experience to perform the job. Have it done by a qualified dealer.

1. Check fluid level once a year. If necessary add distilled water (or clean rain water) to bring level to bottom of cell neck. Do not add water in freezing temperatures unless engine is run two to three hours to mix electrolyte.
2. Check battery charge once a year, more often if operating in cold weather. Hydrometer readings should be 1.260 to 1.300. Readings below 1.250 indicate charging is required. See "Charging Battery".
3. Keep battery clean by wiping it with a damp cloth.
4. Keep all connections clean and tight. Remove any corrosion and wash terminals with a solution of baking soda and water. A light coating of grease on terminals (after cables are attached) will reduce corrosion.
5. A replacement battery must have a rating of at least 640 cold cranking amps at 0°F (-18°C).

IMPORTANT: BATTERY IS NEGATIVE GROUNDED. Always connect starter cable to the positive (+) terminal of battery and battery ground cable to negative (-) terminal of battery. Reversed polarity in battery or alternator may result in permanent damage to electrical system.

MAINTENANCE/SERVICE

Electrical System

BATTERY (continued)

CHARGING BATTERY



CAUTION:

- Ventilate the area where batteries are being charged.
- Do not charge a frozen battery. Warm to 60°F (16°C) before charging.
- Do not connect or disconnect live circuits. To prevent sparks, turn off charger and connect positive cable first. If charging battery in windrower, disconnect positive battery cable before connecting charger cable, then connect ground cable last, away from battery.
- Stop or cut back charging rate if battery feels hot, or is venting electrolyte. Battery temperature must not exceed 125°F (52°C).
- Follow all instructions and precautions furnished by the battery charger manufacturer. Charge at recommended rates and times.

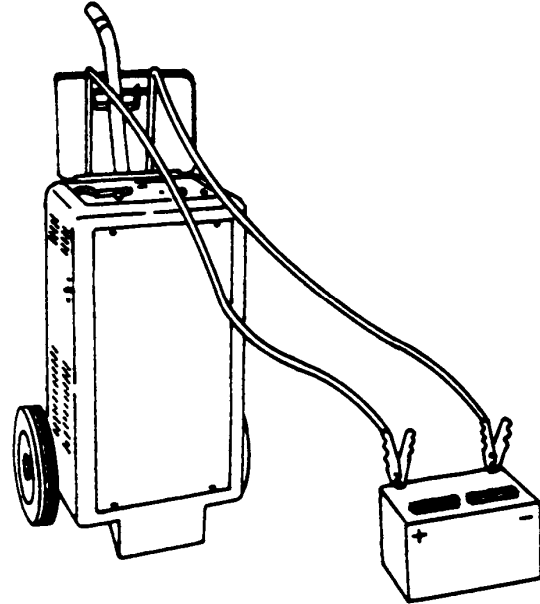

CHARGE BATTERIES SAFELY

USING A BOOSTER BATTERY

A twelve volt battery can be connected in parallel (+ to +) with the windrower battery. Use heavy duty battery cables.



CAUTION: Gas given off by batteries is explosive. Keep sparks and flames away from batteries. Make last connection and first disconnection at a point furthest away from the batteries. Wear protective eye-wear when using a booster battery. Be sure everyone is clear of machine when starting engine. Start engine from operator's station only.

1. Attach one cable to positive terminal (A) of booster battery.
2. Open engine compartment hood and attach other end of cable to positive terminal (B) of windrower battery.
3. Attach second cable to negative terminal (C) of booster battery and then to a good ground (D) on windrower frame.
4. Turn ignition switch in cab as with normal start up.
5. When disconnecting cables, remove cable from ground (D) first.



CAUTION: Avoid contact with moving parts when disconnecting cable at windrower battery terminal (B). Never wear loose fitting or dangling clothing or jewellery.

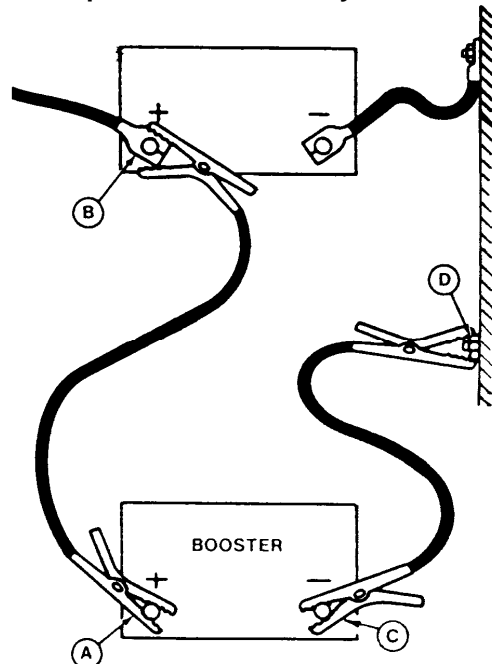

ATTACHING BOOSTER BATTERY

MAINTENANCE/SERVICE

Electrical System

PREVENTING ALTERNATOR AND REGULATOR DAMAGE

1. Always disconnect battery ground cable when working with the alternator or regulator.
2. Never attempt to polarize alternator or regulator.
3. If wires are disconnected from the alternator (B) or regulator (C), use the photo at right to ensure proper reconnection.
4. Never ground the alternator field terminal or field circuit.
5. Never connect or disconnect alternator or regulator wires with battery connected or alternator operating.
6. Always disconnect cables from the battery when using a charger to charge battery in windrower.
7. Connect all cables before operating engine.

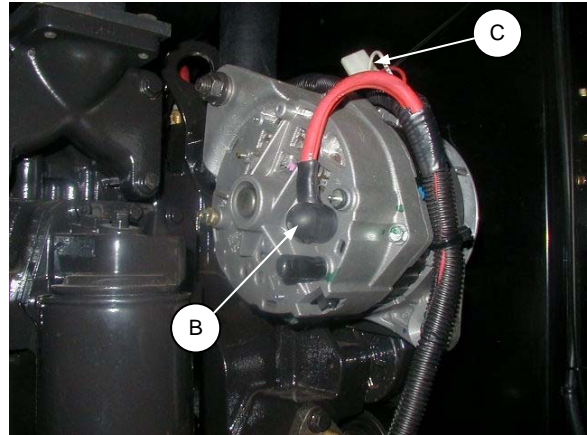

ALTERNATOR/REGULATOR WIRING

MAINTENANCE/SERVICE

Electrical System

LIGHTS AND BULBS

ADJUSTABLE HEADLIGHTS

The two front headlights can be adjusted up or down and to the right or left with adjustment screws (A). Adjust for maximum illumination while ensuring oncoming traffic cannot be blinded by the lights. The recommended setting is:

- Light beams laterally centered on the "direction of travel" line from the headlights (i.e. not skewed left or right).
- Upper limit of the beam not higher than 105 inches (266 cm) above ground at a distance of 25 ft. (7.5 m) from the headlight

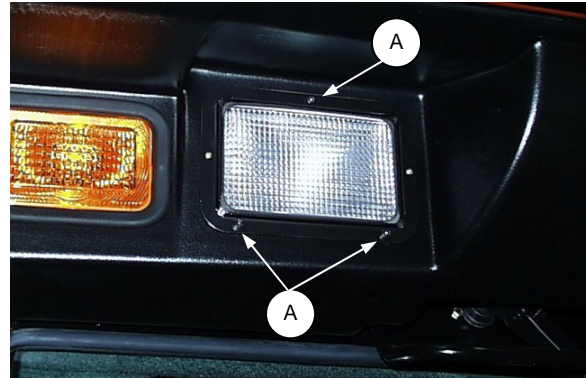

HEADLIGHT ADJUSTMENT

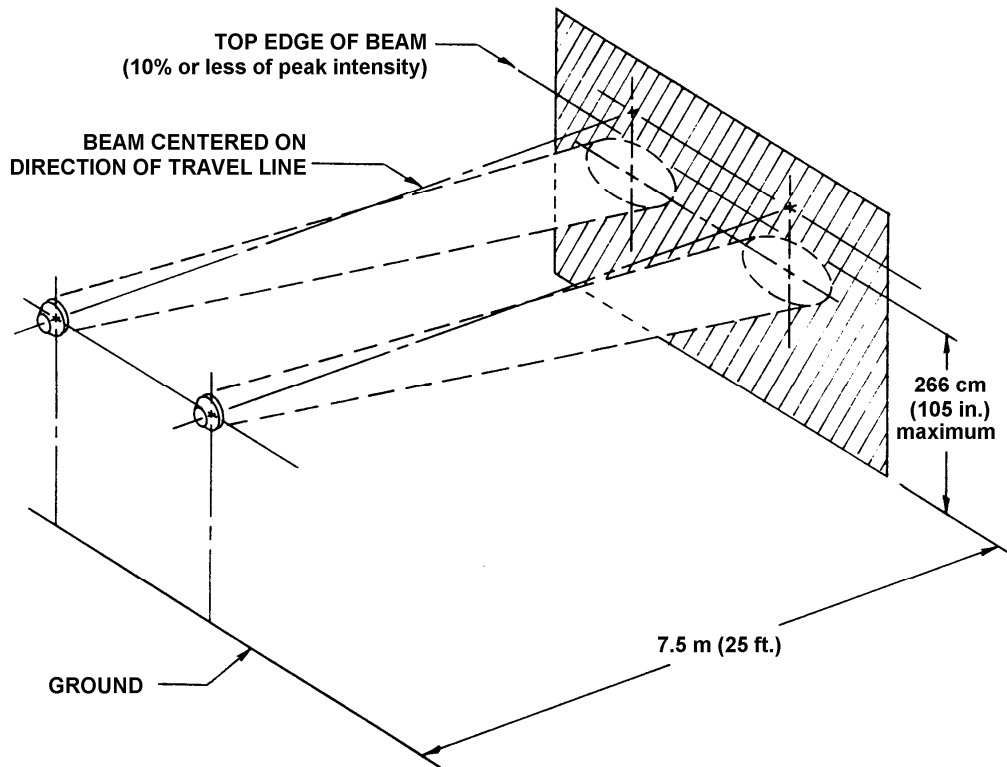

SERVICING LIGHT BULBS

1. If all lights fail at the same time, check if re-set button is popped out on the lights circuit breaker at the engine. If so, push it in. See "Circuit Breakers" in this section.
2. If a single light fails, bulb may be burned out, or it may have a faulty connection.
3. If problem is other than circuit breaker, bulb, or connection, see your Windrower dealer.

MAINTENANCE/SERVICE

Electrical System

LIGHTS AND BULBS (continued)



CAUTION: To avoid a slip and fall injury when replacing lamps at front of machine, remove header and use a step ladder, unless header has a traction surface across the back tube.

REPLACING HEAD LIGHT BULBS

1. Turn light switch and ignition key to OFF.
2. Remove two screws from lamp bezel (A) and remove light assembly from roof.
IMPORTANT: Do not remove the three adjusting screws.
3. Turn old bulb to align tabs on bulb with cut-outs in socket. Remove old bulb and detach wiring harness connector

IMPORTANT: To prevent premature failure of bulb, do not touch the glass surface with bare hands.

4. Attach harness connector to new bulb (#9005) and install bulb into socket.
5. Reinstall light and bezel, securing with two screws.
IMPORTANT: For proper lighting pattern, be sure lights are installed right side up.
6. Aiming of headlights should not be necessary.

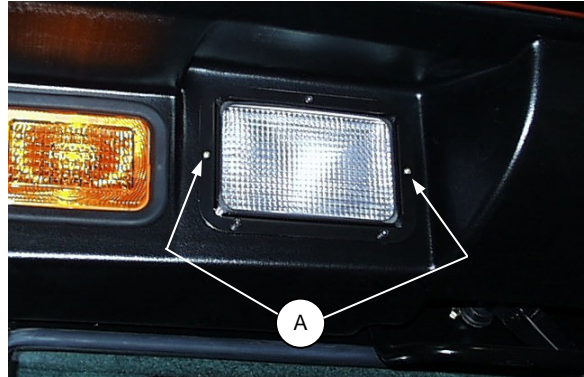

REPLACING HEADLIGHT BULB

REPLACING FIELD LIGHT BULBS

1. Turn light switch and ignition key to OFF.
2. Remove two screws from lamp bezel (A).
3. Release clip and remove bulb unit.

IMPORTANT: To prevent premature failure of bulb, do not touch the glass surface with bare hands.

4. Unplug connector (B) and connect new bulb. Install and secure with clip.
5. Replace light and bezel, securing with two screws.
IMPORTANT: For proper lighting pattern, be sure lights are installed right side up.

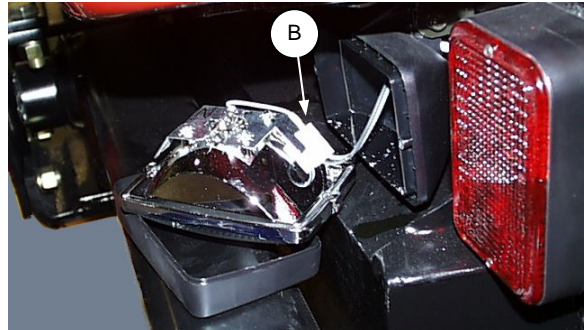
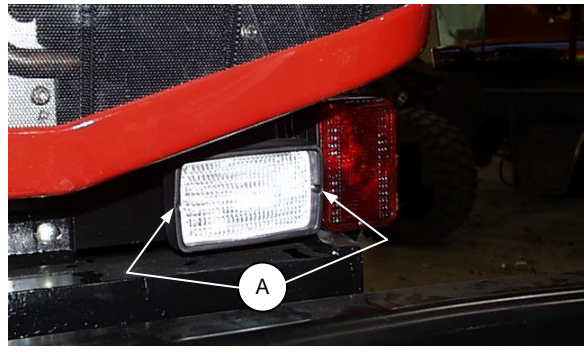

REPLACING FIELD LIGHT BULB

MAINTENANCE/SERVICE

Electrical System

LIGHTS AND BULBS (continued)

REPLACING RED TAIL LIGHT BULBS

1. Remove two screws (A). Remove plastic lens.
2. Replace bulb and reinstall plastic lens.

NOTE: Bulb trade #1157.



RED LIGHTS

REPLACING AMBER LIGHT BULBS

1. Remove light (B) from rubber bezel.
2. Replace bulb and reinstall light.

NOTE: Bulb trade #1156.

IMPORTANT: For proper lighting pattern, be sure lights are installed right side up.

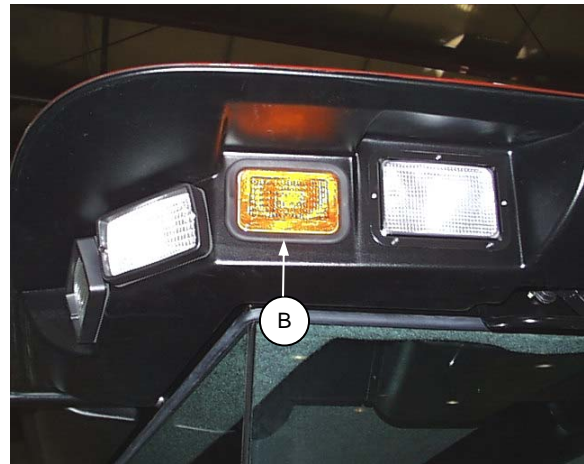

AMBER LIGHTS

REPLACING GAUGE LIGHT BULBS

1. Turn light switch and ignition key to OFF.
2. Remove six screws (three per side) from instrument panel (A). While pulling out on top of instrument panel, pull up until panel clears side console.
3. To replace gauge lights, twist and pull bulb holder (D) from back of gauge and replace bulb.

NOTE: Bulb trade #161.

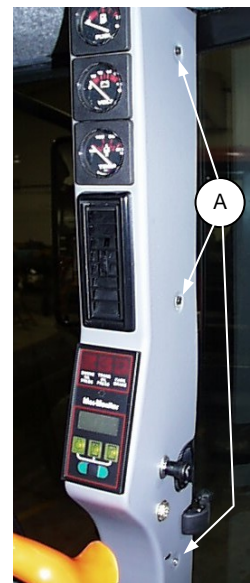
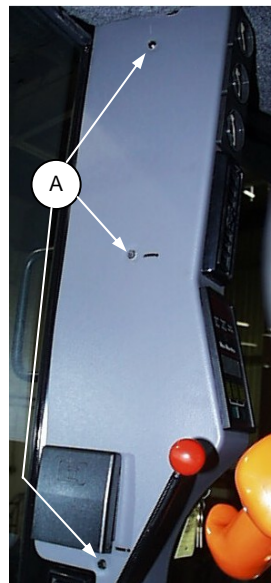
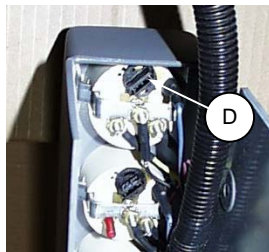

REMOVE INSTRUMENT PANEL

MAINTENANCE/SERVICE

Electrical System

LIGHTS AND BULBS (continued)

REPLACING DOME LIGHT BULB

1. Remove two screws (D) from plastic lens.
2. Replace bulb and reinstall plastic lens.

NOTE: Festoon Bulb 12V-21 CP

REPLACING TURN SIGNAL INDICATORS

1. Remove six screws around outer edge of cover (F). Lower cover to expose inner wiring.
2. Push out entire unit (E), detach wiring and replace.
3. Reinstall cover (F).

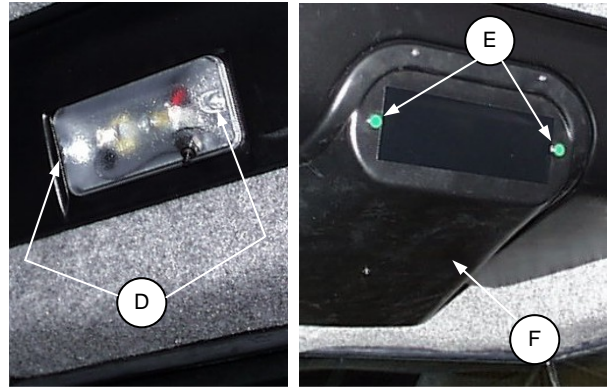

DOME LIGHT AND TURN INDICATORS

Electrical System

FUSE BLOCK

CHECKING/REPLACING FUSES

The fuse block is located on the LH side of the engine compartment mounted to the fire wall. The fuses are the plastic blade type. To access the fuse block refer to the illustration and proceed as follows.

1. Remove screws (A) and remove fuse block cover.
2. Refer to the decal on the inside of fuse block cover. See Illustration.
3. To check fuse, pull fuse out of receptacle and visually examine.
4. To replace fuse, insert into receptacle.

IMPORTANT

Replacement fuses should match rating on decal.

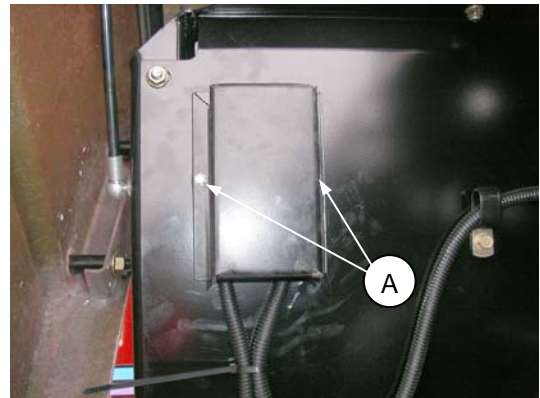

FUSE BLOCK COVER

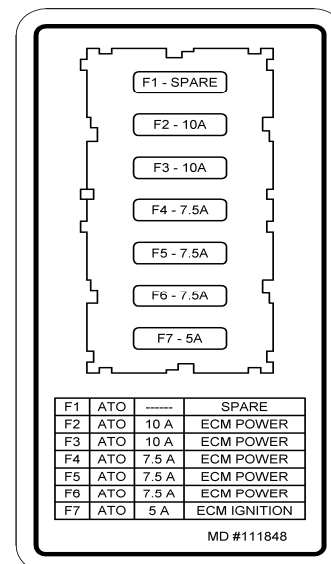

FUSE BLOCK DECAL

MAINTENANCE/SERVICE

Electrical System

CIRCUIT BREAKERS

CHECKING IN-CAB CIRCUIT BREAKERS

For access to breakers, remove panel (G) on window side of right hand side console.

These breakers will reset automatically after approximately one minute.

See your dealer if circuits do not operate correctly.

- (A) - Wiper, Interior Light, Radio Memory, Auxiliary Power Points - 6 amp
- (B) - Instruments, Radio, Screen Motors - 6 amp
- (C) - Header Controls, Operator Presence System, 2-Speed Switch - 10 amp
- (D) - Air Conditioning, Seat Suspension Switch - 25 amp

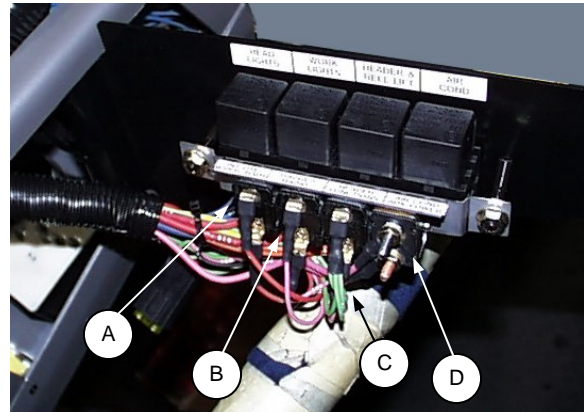
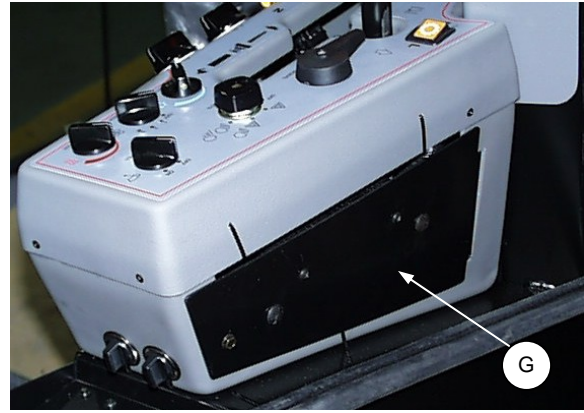

IN-CAB CIRCUIT BREAKERS

CHECKING 50 AMP CIRCUIT BREAKERS

The 50 amp circuit breakers are located at the left radiator mount.

NOTE: Circuit breaker (E) provides power for all lights except rear work lights, which are powered with other electrical functions through breaker (F).

If none of the lights will operate, check if re-set button is popped out on lights circuit breaker (E). (Button is located on bottom of breaker mounted inside of shield and can be reached by hand)

If none of the electrical functions other than lights will operate, check if re-set button is popped out on bottom of circuit breaker (F).

If re-set button is out, the breaker has opened. Push the button in to reset circuit breaker.

Breakers should not open regularly under normal operating conditions. If repeated breaker opening occurs, see your dealer.

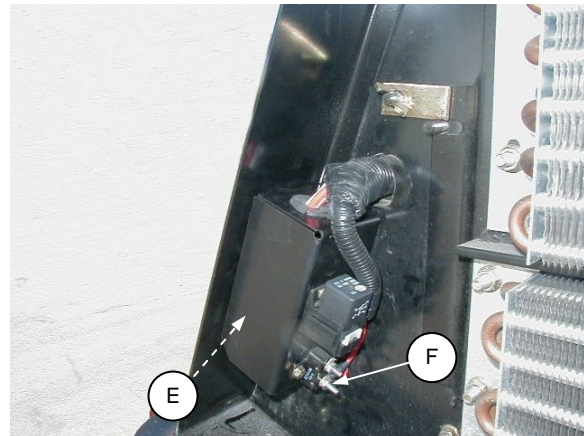

50 AMP CIRCUIT BREAKERS

NOTE: For electrical schematics, see "SCHEMATICS" section at back of this book.

RADIO & TWO-WAY RADIO INSTALLATION

Instructions for installation of a radio and two-way radio are provided in Assembly section.

MAINTENANCE/SERVICE

Hydraulic System



WARNING: Avoid high pressure fluids. Escaping fluid can penetrate the skin causing serious injury. Relieve pressure before disconnecting hydraulic lines. Tighten all connections before applying pressure. Keep hands and body away from pin-holes and nozzles which eject fluids under high pressure. Use a piece of cardboard or paper to search for leaks. If ANY fluid is injected into the skin, it must be surgically removed within a few hours by a doctor familiar with this type of injury or gangrene may result.

IMPORTANT: Dirt, dust, water and foreign material are the major causes of trouble developing in the hydraulic system. If the hydraulic system should be disconnected for service, protect the ends of hoses, tubing and ports of components from contamination with clean, lint-free towels or clean plastic bags. Before installing any replacement hose, flush the inside of it with unused diesel fuel or unused commercial petroleum cleaning solvent for ten seconds minimum. Do not use water, water soluble cleaners or compressed air.

IMPORTANT: The components in this system are built to very close tolerances and have been adjusted at the factory. Do not attempt to service these components except to maintain proper oil level, change oil and filters and to adjust relief pressures as described in this manual. See your Windrower Dealer for all other service.

HYDRAULIC OIL COOLER

Clean daily with compressed air. See "Screens and Coolers" under Cooling System Maintenance.

HYDRAULIC OIL

With tractor on level ground, check hydraulic oil level daily on dipstick (A).

Maintain level between "LOW" and "FULL" marks, with header lift cylinders retracted. See recommended oil on page 59.

CAPACITY - LOW MARK TO FULL:
1 U.S. gallon (4 litres)

When storing machine for an extended time, add oil to top of filler neck. Drain off excess oil to proper level before next use by removing drain plug (B) from bottom of reservoir.

Replace plug and check level at dipstick.

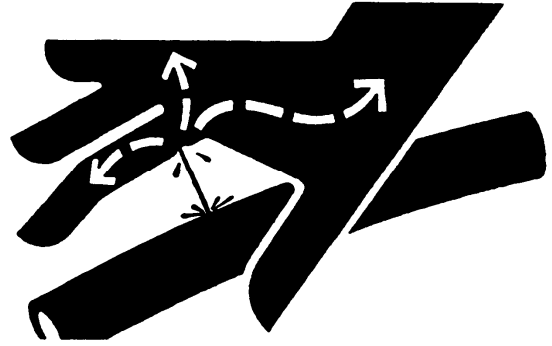

AVOID HIGH PRESSURE FLUIDS

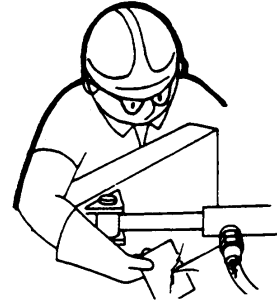

CHECK PROPERLY FOR LEAKS

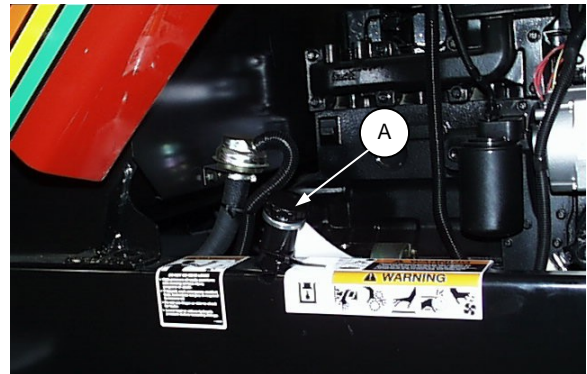

HYDRAULIC OIL DIPSTICK

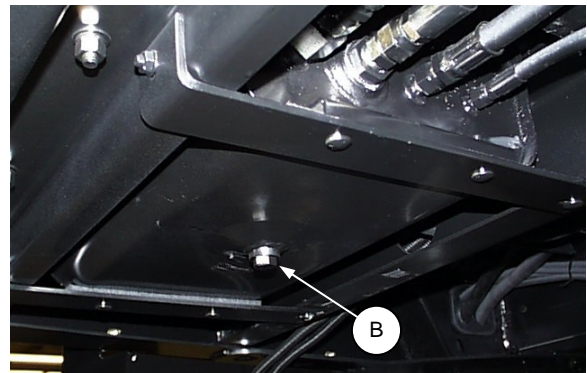

TO DRAIN EXCESS OIL

MAINTENANCE/SERVICE

Hydraulic System

HYDRAULIC OIL

Change hydraulic oil every 2000 hours.

NOTE FOR FLEET OWNERS: If you *also* operate an older MacDon built windrower tractor with a production year '99 or earlier, that unit's hydraulic system will be filled with 10W30 engine oil. It is recommended that the change be made to single grade trans-hydraulic oil at the next scheduled oil change. See page 59 for recommended brand names.

To change:

1. Remove drain plug (B) from bottom of reservoir. Allow oil to drain.
NOTE: A drain pan with a capacity of 20 U.S. gallons (75 litres) will be required.
2. Replace the hydraulic oil filter. See "Hydraulic Oil Filters" in this section.
3. Clean off any metal debris which may have accumulated on magnetic drain plug. Replace plug (B).
4. Fill the system with oil through the filler neck. See "Fuels, Fluids and Lubricants" page 59 for recommended oil type. Check oil level with dipstick periodically during filling to prevent spill-over.

CAPACITY:

Reservoir only: 15.2 US gal. (57 litres)
Total system: approximately 17 US gal.
(65 litres)(varies with options)

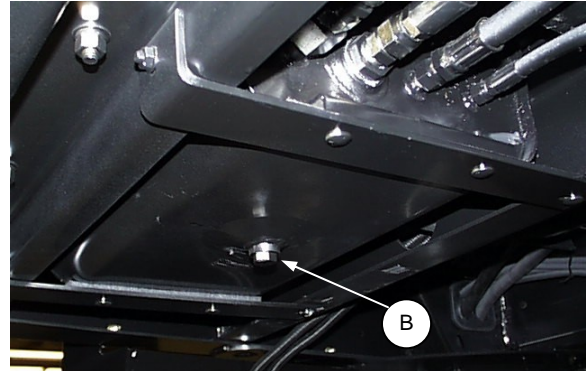

TO DRAIN HYDRAULIC OIL

HYDRAULIC OIL FILTERS

Change hydraulic oil filters after the first 10 hours of operation and every 300 hours thereafter.

- Filter (A) is located at right side of engine compartment, under side panel.
- Filter (B) is located just ahead of frame cross channel, near hydrostatic pump.

To change:

1. Clean around the filter head.
2. Remove the filter element and clean the gasket surface of the filter head.
3. Apply a thin film of clean oil to the gasket on the new filter.
4. Install new filter. Turn the filter onto the mount until the gasket contacts the filter head. Tighten the filter an additional 1/2 turn by hand.

IMPORTANT: Do not use a filter wrench to install the oil filter. Over-tightening can damage gasket and filter.

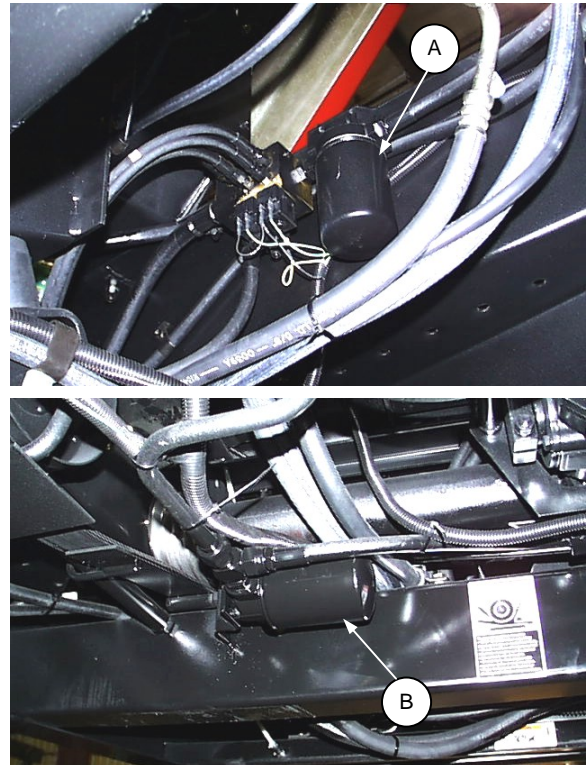

HYDRAULIC OIL FILTERS

MAINTENANCE/SERVICE

Hydraulic System: Header & Reel Lift

CYLINDER CONTROL VALVE RELIEF PRESSURE

Control valve (A), located under the R/H tractor floorboard, directs hydraulic flow to the header lift cylinders, reel lift cylinders and the cylinder used to engage the clutch for the sickle drive.

The control valve relief pressure is pre-set to be sufficient for all header sizes and options. Should lift capacity problems develop, check and adjust cylinder control valve relief pressure as follows:

1. Lower header and reel fully, stop engine and remove key from ignition.
2. The same relief valve protects both header and reel lift circuits. It is most convenient to check relief pressure in the reel lift circuit.
For tractors with reel lift hydraulics, reel lift quick coupler (B) is located at left-hand leg.
For tractors without reel lift hydraulics, the header lift circuit may be tapped at Port "C" of the lift valve. Remove hose (C) to access port.
3. Attach a 3000 psi (20 MPa) pressure gauge to a hose that is long enough to allow pressure to be read from the operator's seat. Attach hose to quick coupler or valve (see step 2) and position gauge to be visible from the seat.
4. Start engine and position throttle lever fully back (low idle). When oil is warm (minimum 100° F (38° C)), activate the lift control for the circuit you have tapped (reel or header) and check gauge pressure reading.
5. Pressure should be 2400 to 2650psi (16.5 to 18.2 MPa)
If not, proceed with adjustment:
EXCEPTION: 36' 972 Header requires 2500 psi (17.2 MPa).
6. Lower header and reel fully. Stop engine and remove key.
7. To adjust relief setting:
 - Loosen jam nut at relief valve (D).
 - Turn the adjustment screw in 1/4 turn increments, clockwise to increase relief pressure, counter-clockwise to decrease.
8. Repeat checking and adjustment until relief pressure is correct, then tighten nut at (D).

IMPORTANT: If relief pressure does not increase after adjusting the screw two or three times, check relief valve as follows: Remove relief valve (D) from control valve block. Check that no contaminant is preventing the spring-loaded poppet from properly seating against the valve body. Clean as required, and reinstall valve. Reset adjustment screw to original position before checking relief pressure.

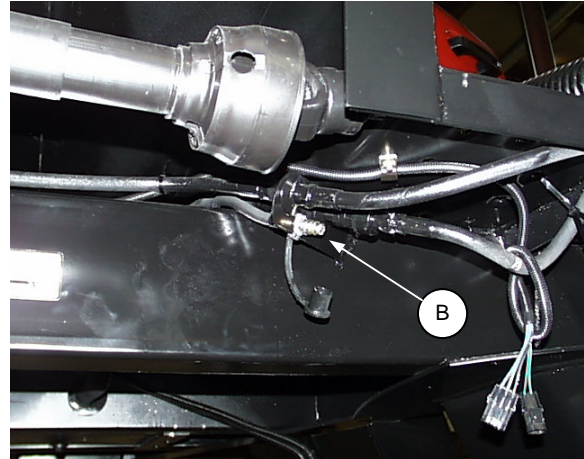

REEL LIFT QUICK COUPLER

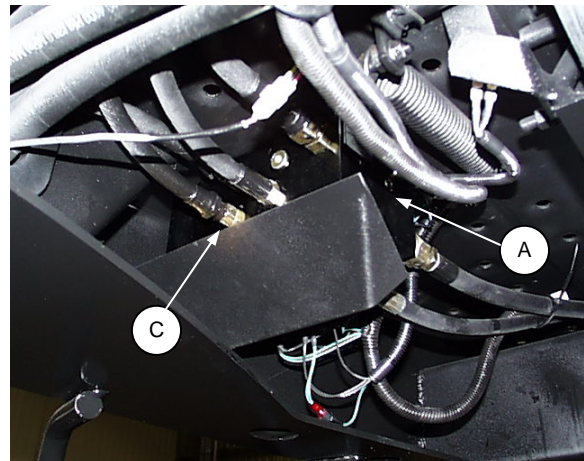

CYLINDER CONTROL VALVE (FRONT VIEW)

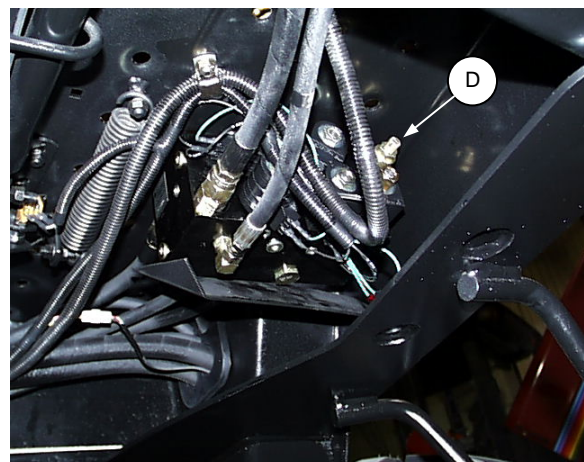

CYLINDER CONTROL VALVE (REAR VIEW)

NOTE: For hydraulic schematics, see "SCHEMATICS" section at back of this book.

MAINTENANCE/SERVICE

Header Drive: Hydraulics

FLOW CONTROL BLOCK

Flow control block (A), located under cab near ground speed linkage, provides hydraulic power to the header. The block divides pump output of 19 gallons per minute (gpm) and controls the flow of oil into two circuits. Flow is used by the various headers as follows:

Auger Header

Both circuits combine to supply oil to the reel drive. Flow can be varied from 6 to 19 gpm with either reel or conveyor speed control knob on cab console.

Harvest Header and Multi-Crop Header

The flow to each circuit (reel and conveyor) can be varied from 3 to 9 gpm.

Header Drive Relief Pressure

Overload protection for the reel and conveyor drives is provided by an internal relief valve in flow control block (A). Should stalling problems develop with one of the header hydraulic circuits, check and adjust relief pressure as follows:

1. Attach a 3000 psi (20 MPa) pressure gauge to a hose that is long enough to allow pressure gauge to be read from the operator's seat. Attach pressure gauge hose to female coupler (E) at the tractor right hand leg and position the gauge to be visible from the seat.
2. Set controls as follows:
 - Start engine and run at operating speed.
 - Move header drive switch to engaged position.
 - Adjust reel speed control to minimum. (Reel should be turning slowly.)
3. Pressure should be 2200 to 2350 psi (15.2 to 16.2 MPa). If not, proceed with adjustment:
4. Move header drive switch to disengaged position. Shut off engine and remove key.
5. To adjust relief setting:
 - Loosen jam nut at relief valve (B).
 - Turn the adjustment screw in 1/4 turn increments, clockwise to increase pressure, counter-clockwise to decrease.
6. Repeat checking and adjustment until relief pressure is correct, then tighten jam nut at (B).

IMPORTANT: If relief pressure does not increase after adjusting the screw two or three times, check relief valve as follows: Remove relief valve (B) from flow control block. Check that no contaminant is preventing the spring-loaded poppet from properly seating against the valve body. Clean as required, and reinstall valve. Reset adjustment screw to original position before checking relief pressure.

NOTE: For hydraulic schematics, see "SCHEMATICS" section at back of this book.

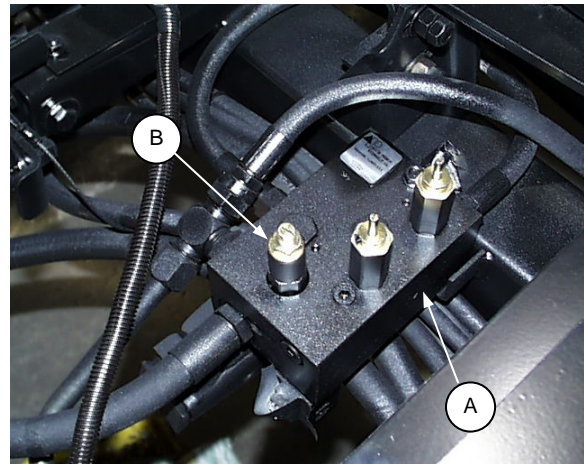

HEADER DRIVE FLOW CONTROL BLOCK



ATTACH PRESSURE GAUGE

MAINTENANCE/SERVICE

Header Drive

BEVEL GEAR BOX LUBRICANT

The bevel gear box directs power from the main drive train to the header drive at the right side of the tractor.

See “Fuels, Fluids and Lubricants” for recommended lubricant.

Check lubricant level as follows:

1. Check level with engine stopped.
2. Loosen level plug (B) (13 mm wrench required) located on extension tube of gear box.
3. Add lubricant at filler location (A) to level plug (B).
4. Replace plugs.

Change lubricant after the first 50 hours operation and every 200 hours (or annually) thereafter, as follows:

1. Drain lubricant from box at drain plug (C) (13 mm wrench required).
2. Replace plug (C), and refill at filler location (A) to level plug (B) (13 mm wrench required).
3. Replace plug (B) and run engine at idle for two or three minutes.
4. Stop engine and allow lubricant to settle for two or three minutes.
5. Top-up lubricant to level plug (B).

CAPACITY – 1.7 US quart (1.6 L)

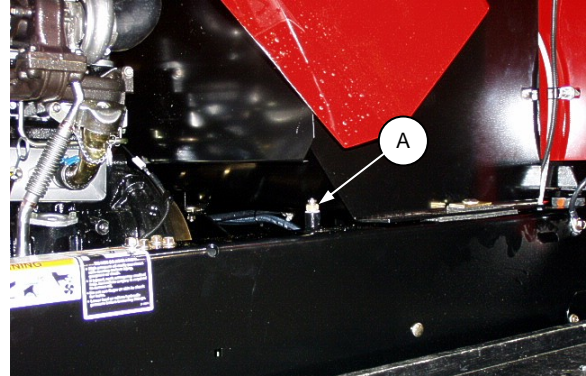

BEVEL GEAR BOX - FILLER LOCATION

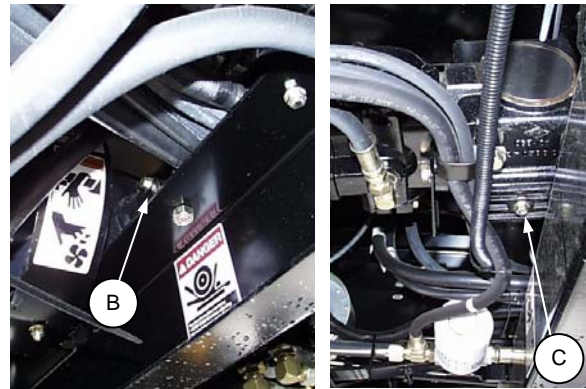

BEVEL GEAR BOX

HEADER DRIVE BELT

This belt runs from the bevel gear box output shaft to the header drive pulley. This drive provides power (through the driveline) for all mechanical header drives. The drive is engaged by means of an electric over hydraulic clutch activated by the header drive switch in cab. Belt tension is maintained by a hydraulic cylinder and manual adjustment of tension is not required.

NOTE: Engine will not start if header drive belt is engaged.

To remove header drive belt:

1. Remove header drive pulley shield.
2. Remove belt from header drive pulley (A).
3. At rear pulley, remove hardware at (C), loosen the lower guide and remove lower belt strand. Bring belt up between top guide and pulley (B).

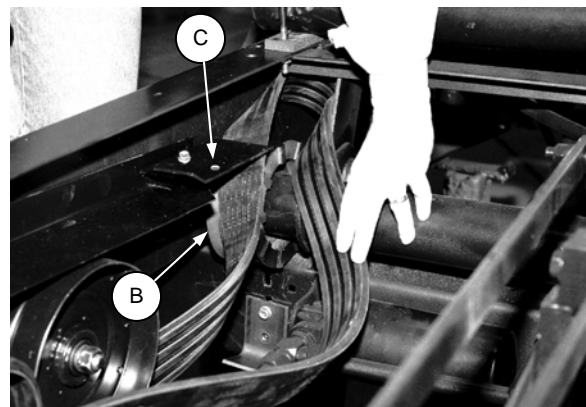
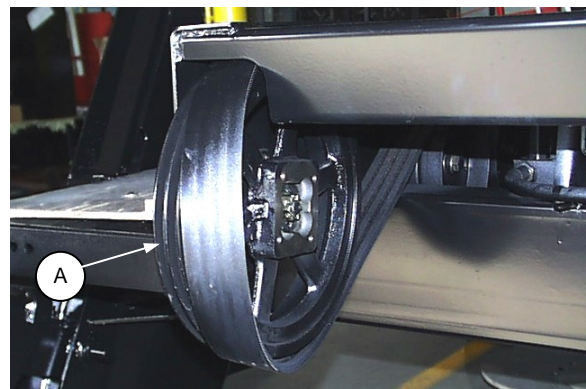

REMOVING HEADER DRIVE BELT

MAINTENANCE/SERVICE

Header Drive

HEADER DRIVE BELT: PULLEY FORE-AFT ALIGNMENT

Fore-aft misalignment of pulleys can cause a belt failure where the backing band splits between V-belt sections, as shown at (A).

Check and correct the pulley fore-aft alignment in the following order:

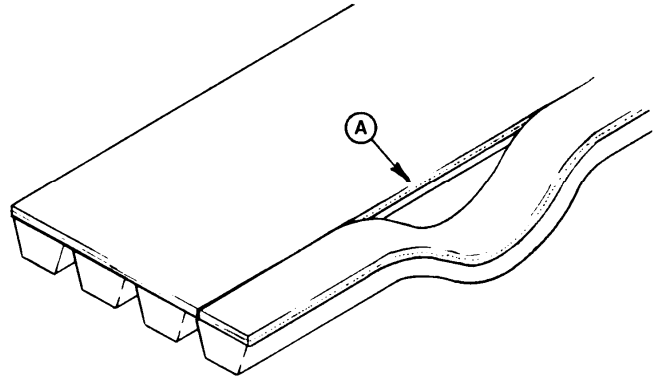

BELT FAILURE DUE TO FORE-AFT MISALIGNMENT

1. Rear pulley must be square to frame as shown. To check, place a straight edge along side of rear pulley and check that clearance to frame at (L) and (M) is equal. To adjust, loosen nut (N) and move R/H gearbox mount forward or back to square rear pulley. Tighten nut (N) to secure the position.

NOTE: Dimension at (L) and (M) should be approximately 17 mm (0.67"), but never less than 13 mm (0.51") to allow for removal and installation of drive belt.

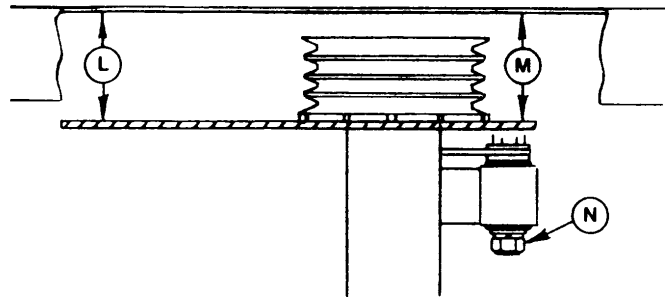

REAR PULLEY SQUARE TO FRAME

2. Rear pulley must align with front pulley as shown below. To check, place a straight edge along side of rear pulley and check that dimension (C) at front pulley is 6 mm (0.24"). To adjust, loosen taper lock bushing (T) at rear pulley and move pulley on gearbox shaft. Ensure that pulley hub or bushing does not contact gearbox seal. Tighten bushing (T) to secure the position.

NOTES: · If (C) is different than (D), see step 4.

· If 6 mm dimension can not be achieved by moving bushing (T), go back to step 1 and purposely misalign rear pulley with frame to obtain 6 mm dimension at (C). Then proceed with steps 3 and 4.

3. Flat idlers must align with each other as shown. Dimension (F) must equal dimension (G) within 2 mm (0.08"). To adjust idlers, bend mounting arms to suit. (It may be necessary to heat idler arms to permit adequate bending.)

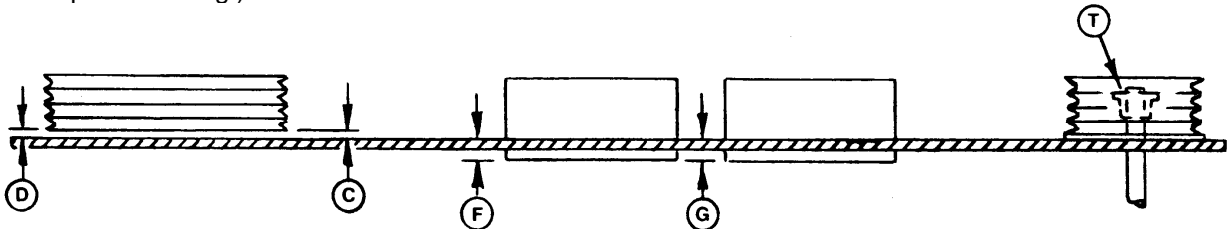

REAR PULLEY ALIGNED WITH FRONT PULLEY AND IDLERS ALIGNED

4. Front pulley must be square to rear pulley as shown. To check, place a straight edge along side of front pulley and check that dimension (E) is 6 mm (0.24"). To adjust, shim front pulley mounting plate at both front bolts, or both rear bolts so that dimensions (C), (D) and (E) are all 6 mm (0.24").

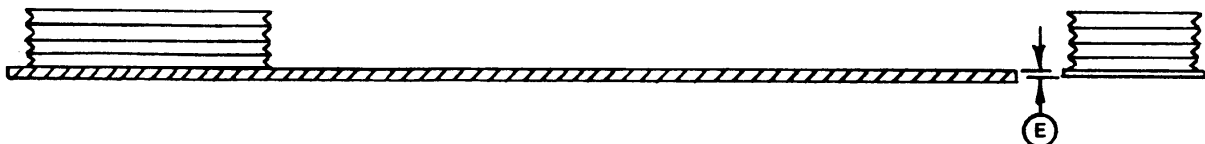

FRONT PULLEY SQUARE TO REAR PULLEY

MAINTENANCE/SERVICE

Header Drive

HEADER DRIVE BELT: PULLEY VERTICAL ALIGNMENT

Vertical misalignment of front pulley can cause a belt failure where sections of the backing band are missing, as shown at (T). The missing sections will vary from 1/2 inch to 5 feet long. Failure starts with cracks across the backing band from one side to the other, followed by pieces falling off.

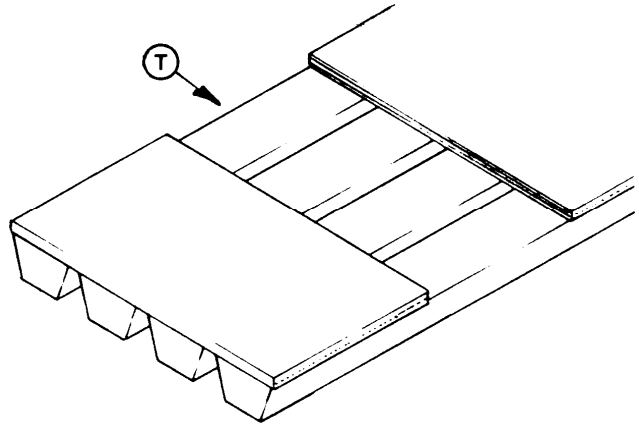

BELT FAILURE DUE TO VERTICAL MISALIGNMENT

Front pulley (P) and two flat idlers must be vertically square (90°) to rectangular frame tube (R) as shown.

To adjust front pulley, shim the pulley mounting plate at both top bolts, or both bottom bolts depending on the direction of the misalignment.

To adjust flat idlers, bend mounting arms to suit. (It may be necessary to heat idler arms to permit adequate bending.)

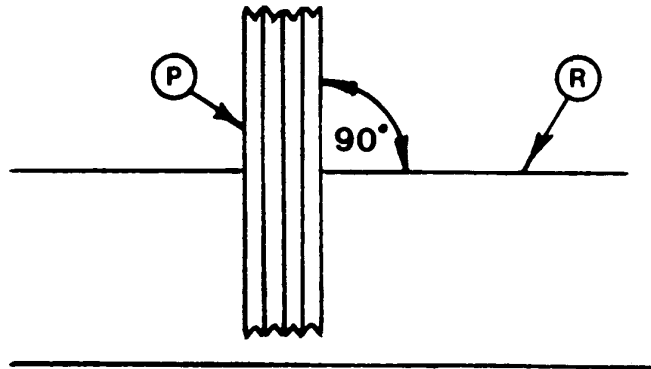

FRONT PULLEY & IDLERS SQUARE TO RECTANGULAR FRAME TUBE

HEADER DRIVE BELT GUIDES

Improper adjustment of belt guides can cause belt to jump one pulley groove. This will result in a belt failure characterized by one outer portion of backing band being frayed and separated from one V-belt as shown at (G). The other V-belts will still be attached to band and the band will not be cracked through from side to side.

Belt guides for the header drive belt should be adjusted so they do not rub belt when drive is engaged, but still support belt when drive is disengaged.

See adjustment details, next page.

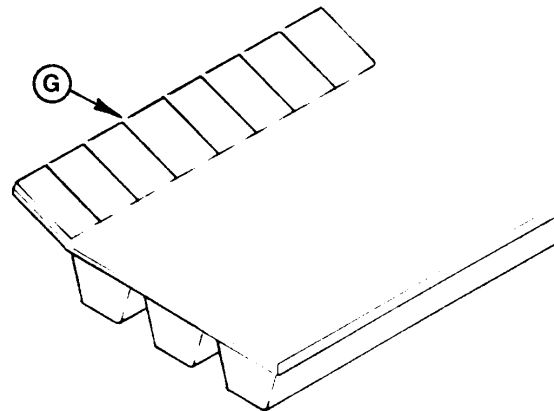

BELT FAILURE DUE TO JUMPING GROOVE

MAINTENANCE/SERVICE

Header Drive

HEADER DRIVE BELT GUIDES (continued)

To adjust:

1. Stop engine and remove key from ignition.
2. Loosen hardware securing top guide (A), belt keeper (B) and lower guide (C).
3. Hold rear idler (D) down with 15/16 wrench to tighten belt.
4. Adjust belt guides and keepers:
 - Adjust top guide (A) to clear belt by 1/4 inch (6 mm) at front. At the back, center the belt between top guide (A) and retainer (E). Adjust hardware (F), both sides, to clear sides of belt.
 - Adjust belt keeper (B) to clear belt by 1/8 inch (3 mm).
 - Adjust lower guide (C) to clear belt by 1/8 inch (3 mm).
5. Tighten hardware.
6. Adjust front pulley shield. (See below.)

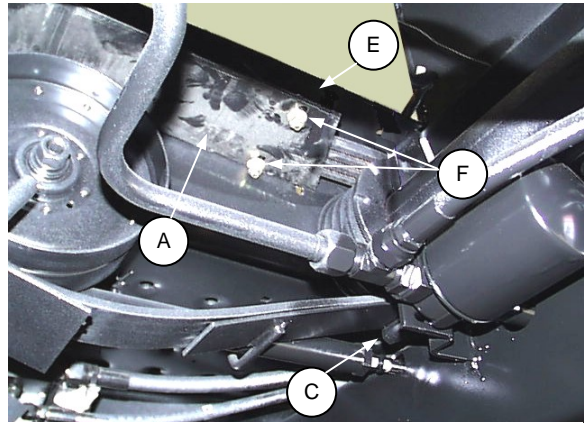
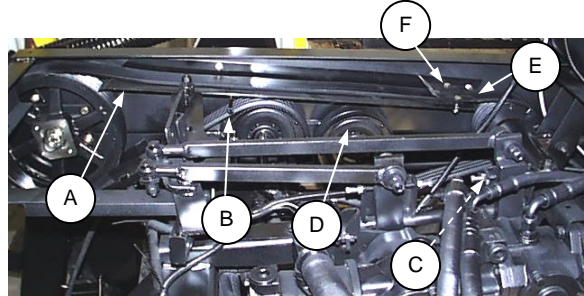

ADJUSTING BELT GUIDES & KEEPER

HEADER DRIVE PULLEY SHIELD

The pulley shield should be adjusted so it does not rub the belt when the drive is engaged.

To adjust:

1. Stop engine and remove key from ignition.
2. Loosen hardware (A) at shield.
3. Push up on lower strand of belt to simulate tightened position (belt fully engaging pulley grooves).
4. Position shield (B) to achieve a consistent 1/8" (3 mm) clearance to belt around entire shield.
5. Tighten hardware (A).

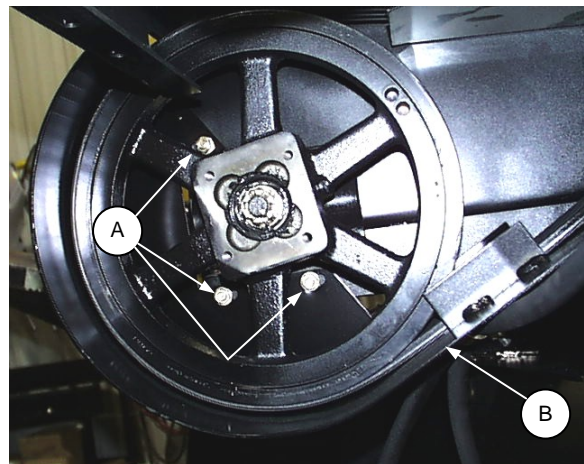

ADJUSTING PULLEY SHIELD

MAINTENANCE/SERVICE

Traction Drive: Hydraulics

TRANSMISSION OIL PRESSURE

Warning light and buzzer in cab will be activated when ignition switch is turned ON if transmission oil pressure is below approximately 150 psi (1035 kPa). Do not drive the windrower until light and buzzer go off. If light and buzzer stay on after engine starts, or if they activate during operation, shut engine off and check hydraulic oil level at reservoir. If oil level is adequate, measure charge pump pressure as described below.

CHARGE PUMP PRESSURE

The charge pump provides hydraulic power to the traction drive. To check charge pump pressure:

1. Remove supercharge line at (A). This line runs between "SC" port on manifold and transmission pump. Place a tee capable of accepting a pressure gauge in the line.
2. Attach a 0 - 600 psi (4000 kPa) pressure gauge to a hose that is long enough to allow pressure gauge to be read from the operator's seat. Attach hose to the tee inserted in Step 1.
3. Start engine and move throttle lever fully forward. Pressure should be 270 to 290 psi (1860 to 2000 kPa).

If pressure is not within this range, adjust relief pressure as follows:

4. Shut off engine and remove key.
5. To adjust relief setting:
 - Remove cap from relief valve (B) for access to adjustment screw.
 - Loosen jam nut at adjustment screw.
 - Turn the adjustment screw in 1/4 turn increments, clockwise to increase pressure, counter-clockwise to decrease.
6. Repeat checking and adjustment until relief pressure is correct, then tighten jam nut and replace cap at (B).

IMPORTANT: If relief pressure does not increase after adjusting the screw two or three times, check relief valve as follows: Remove relief valve (B) from flow control block. Check that no contaminant is preventing the spring-loaded poppet from properly seating against the valve body. Clean as required, and reinstall valve. Reset adjustment screw to original position before checking relief pressure.

NOTE: For hydraulic schematics, see "SCHEMATICS" section at back of this book.

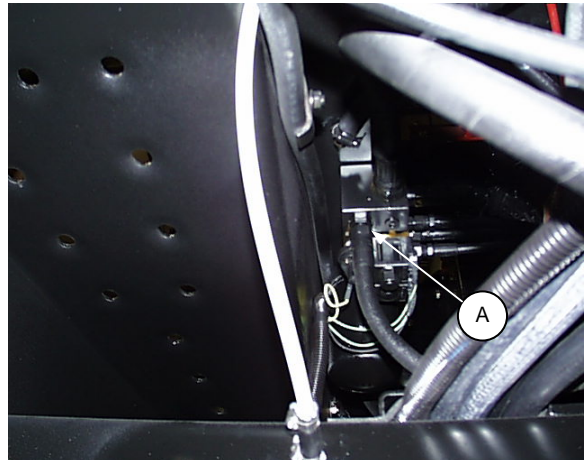

INSTALL TEE IN SUPERCHARGE LINE

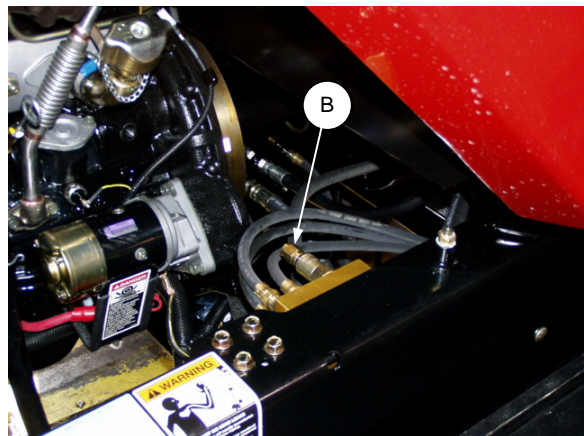

CHARGE PUMP RELIEF VALVE

MAINTENANCE/SERVICE

Traction Drive: Neutral Lock and Steering Checks



DANGER: To prevent machine run-away:

- **STOP ENGINE** before adjusting steering linkage or neutral interlock.
- Never rewire or misadjust neutral interlock so engine can be started with controls out of neutral.
- Never start engine by shorting across starter terminals. Machine will start with drive engaged and move if normal starting circuitry is bypassed.
- Start engine only from operator's seat. Never try to start engine with someone under or near machine.
- Refer to proper start-up procedure in Operation section.

A properly functioning system should operate as follows:

- The starter should engage ONLY when the ground speed lever is in neutral, the steering wheel is locked, and the header drive switch is in the off position.
- Under these conditions, the machine should not move after engine start-up.

If either of the above does not hold true, perform the following nine checks. Adjustments, if required are described following each check point. A troubleshooting section follows the checklist.



DANGER: To avoid severe personal injury or death caused by machine runaway, shut off engine and remove key before performing any of the following checks and/or adjustments.

1. Neutral Start Switch: Check that electrical connections are good at neutral start switch (A). With controls in start-up position as described above, plunger of switch must be compressed. Adjust switch support if required. Do not over-adjust switch support, as this will prevent pintle arms from locking as described in Check # 3.
2. Header Drive Belt Switch: Check that electrical connections are good at header drive belt switch (B). With controls in start-up position, (belt disengaged), plunger of switch must be compressed. Adjust switch support if required.



FOLLOW ADJUSTMENT PROCEDURE

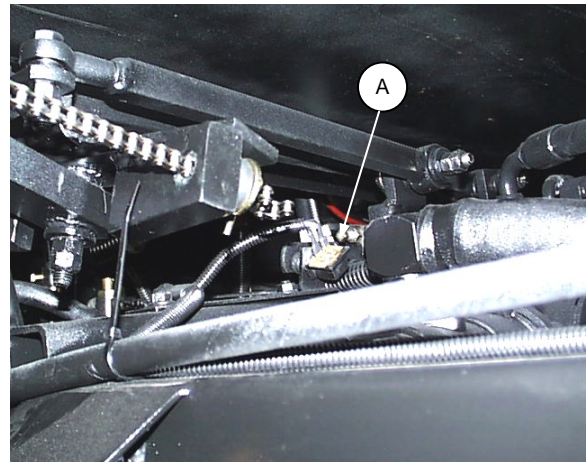

NEUTRAL START SWITCH

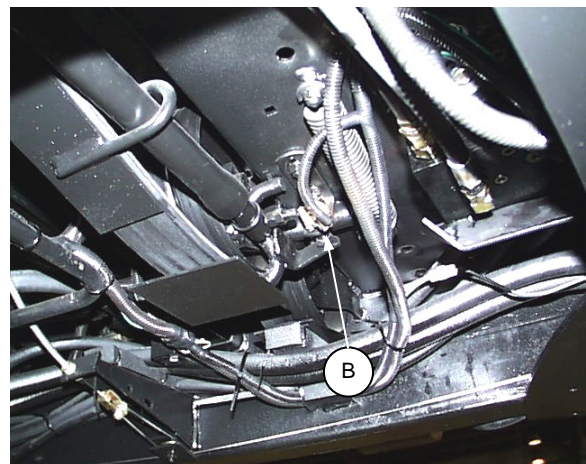

HEADER DRIVE BELT SWITCH

MAINTENANCE/SERVICE

Traction Drive: Neutral Lock and Steering Checks (continued)

3. Neutral Lock Adjustment Bolts Engagement: Check the depth of engagement of the neutral lock adjustment bolts (B) on pintle arms (C). Minimum engagement is 3/8 inch (10 mm), that is, the full diameter of the bolt must contact pintle arms.

To adjust:

- Loosen cable as described in check 4, below.
- Adjust neutral start switch to obtain proper engagement depth.
- Readjust cable as described in check 4.



WARNING: Do not adjust the neutral lock adjustment bolts (B). These bolts can only be adjusted during neutral set-up procedure described at the end of this section.

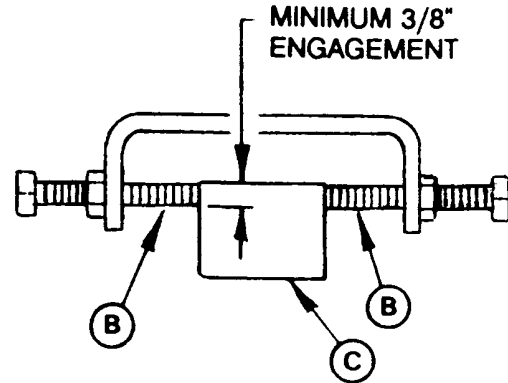

ENGAGEMENT DEPTH:
NEUTRAL LOCK ADJUSTMENT BOLTS

4. Cable Tension: Check tension of cable (D). The cable should be tight when the ground speed lever (F) is at the right hand side of the neutral detent on side console, and when the neutral start switch is fully compressed. If the cable is too tight, it will prevent the neutral start switch from fully compressing and prevent proper engagement of adjustment bolts on pintle arms.

To adjust cable tension, loosen nut (H) on threaded hook bolt (E) and turn nut (J) clockwise to increase cable tension, counter-clockwise to decrease. Tighten nut (H) against nut (J) to secure the position.

5. Ground Speed Lever Pivot: Check the pivot at ground speed lever (F). Nut (L) should be flush with the end of the carriage bolt (full thread engagement). To tighten, hold nut (K) with a wrench and tighten nut (L) against nut (K). Torque nut (L) to 60 to 70 ft.lbs. (80 to 90 N-m).

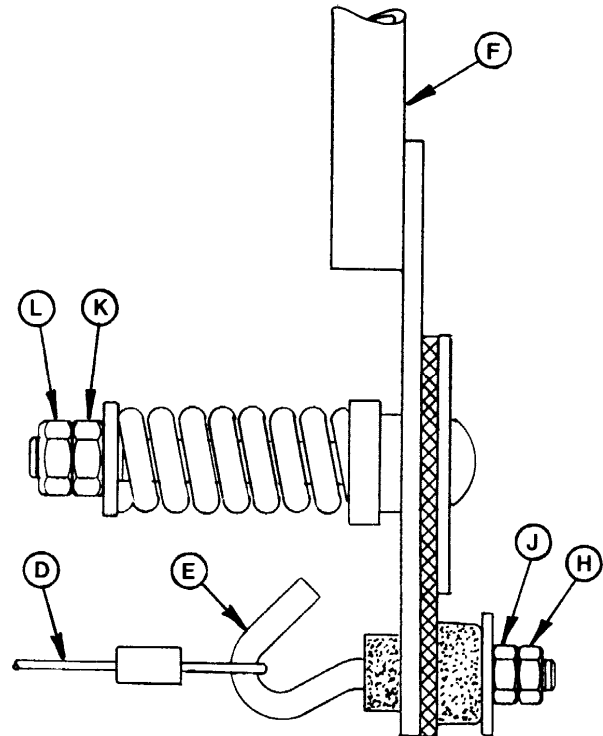

GROUND SPEED LEVER CONNECTIONS

MAINTENANCE/SERVICE

Traction Drive: Neutral Lock and Steering Checks (continued)

6. Radius Arm Pivots: Check the two pivots (A) and (C). At each pivot, torque inner nut (D) to 7 ft.lbs. (10 N-m). Hold inner nut (D) with a wrench and tighten outer nut (E) against nut (D). Torque nut (E) to 60 to 70 ft.lbs. (80 to 90 N-m).

IMPORTANT: Be sure to hold inner nut (D) while tightening outer nut (E). Nut (D) **MUST NOT TURN**.

At ball joint connection (B), torque both nuts to 60 to 70 ft.lbs. (80 to 90 N-m).

7. Ground Speed Lever Position: Check that when the steering wheel is locked, the ground speed lever (F) is centered fore-aft in the neutral detent on side console as shown.

To adjust:

- Loosen bolts (G) (see photo above), allowing bolts to slide in slots.
- Lock the pintle arms in the neutral lock adjustment bolts. See check 3.
- Hold ground speed lever (F) centered fore-aft in neutral detent.
- Have a second person tighten bolts (G) as follows:
 - inner nut: 80 to 90 ft.lbs. (110 to 120 N-m)
 - outer nut: 60 to 70 ft.lbs. (80 to 90 N-m)

8. Neutral Lock Structure: Check for proper movement of support structure (J) for the neutral lock adjustment bolts as follows:

- Disconnect spring (P) to unload pivots.
- Check that support structure (J) rotates freely.
- Check that there is no fore-aft movement of support structure (J).
- If no adjustment is required, reconnect spring (P).

To adjust:

- Turn nut (K) until the washer just contacts the plastic bushing. This pivot must allow free rotation of the support structure.
- Turn nut (L) until the washer contacts the front support. Check again for free rotation of the structure with no fore-aft movement. To lock, hold inner nut (L) with a wrench and tighten outer nut (M) against nut (L). Torque nut (M) to 60 to 70 ft.lbs. (80 to 90 N-m).
- Reconnect spring (P).

9. Loose Hardware: Check all hardware (not included in the previous checks) is properly tightened to torque specifications on ground speed controls, control rods, pump pintle arms and neutral start mechanisms.

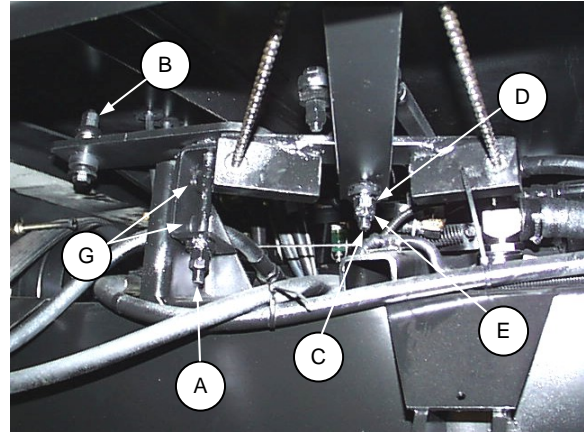

RADIUS ARM

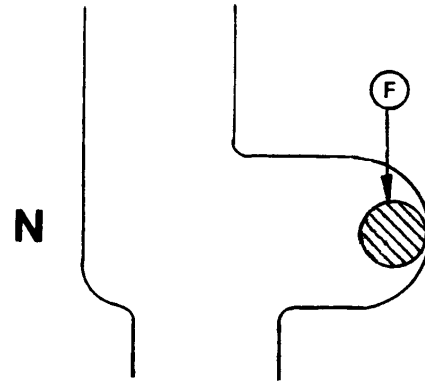

GROUND SPEED LEVER - NEUTRAL DETENT

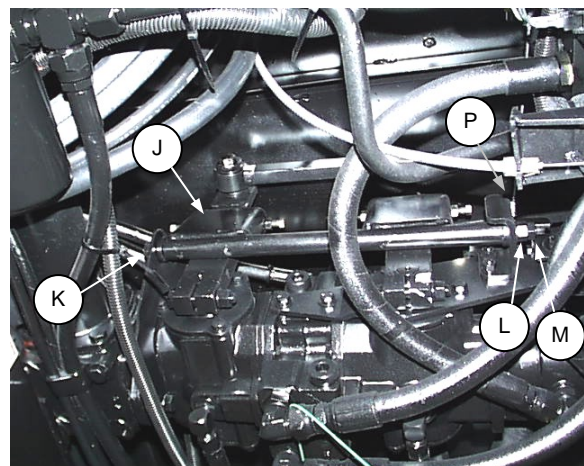

NEUTRAL LOCK STRUCTURE

MAINTENANCE/SERVICE

Traction Drive: Neutral Lock and Steering Troubleshooting

Any problem with the neutral lock and steering controls could be caused by loose, worn, or improperly adjusted parts as described in the preceding nine checks.

IMPORTANT: When servicing this area, it is important to perform all of the nine checks to avoid missing the problem and providing only a temporary fix.

PROBLEM: Steering wheel will not lock in neutral.
TRY CHECK #: 7, 4, 8, 1

PROBLEM: Ground speed lever will not go into reverse or forward.
TRY CHECK #: 4

PROBLEM: Ground speed lever rattles in neutral.
TRY CHECK #: 4, 8

PROBLEM: Ground speed lever not spring loaded towards the center of forward travel slot.
TRY CHECK #: 4, 8

PROBLEM: Steering wheel locks in neutral, but neutral start switch does not compress.
TRY CHECK #: 1, 3, 4, 7, 8. If problem persists, perform "Neutral Set-Up Procedure", next page.

PROBLEM: Machine "growls" severely or moves after engine start up.
TRY CHECK #: 1 - 9. If problem persists, perform "Neutral Set-Up Procedure", next page.

PROBLEM: Steering wheel locks in neutral only after several left to right rotations of wheel.
TRY CHECK #: 3, 4, 7, 8. If problem persists, perform "Neutral Set-Up Procedure", next page.

MAINTENANCE/SERVICE

Traction Drive: Neutral Set-Up Procedure

This procedure should be performed only after the nine preceding checks and adjustments have failed to solve the neutral lock/steering problem.

This procedure will eliminate machine movement in neutral and will improve neutral locking ability.



CAUTION: Use jack-stands with a minimum capacity of 3 tons (2720 kg) to provide adequate support for machine.



DANGER: Never attempt neutral set-up procedure without raising front wheels off the ground so they are free to turn. Failure to raise front wheels will result in machine runaway, causing severe personal injury or death.

1. Detach header and remove hay conditioner forming shields from under tractor.
2. Raise front of machine high enough to allow both wheels to turn freely and support with jack-stands. See "Jacking Procedure" under Wheel & Tire Maintenance in this section.
3. Start engine and idle at approximately 1400 - 1500 RPM.
4. Set controls as follows:
 - Ground speed lever in neutral.
 - Steering wheel locked.
 - Park brake disengaged.
5. Loosen bolts (A), allowing the bolts to slide freely in slots.

NOTE THE FOLLOWING:

- Front pintle arm (B) controls the right wheel and rear pintle arm (C) controls the left wheel.
 - Moving the pintle arms towards the front causes the wheels to turn forward. Moving the pintle arms rearward causes the wheels to turn in reverse.
 - The pintle arms are located in neutral when they are between the forward and reverse positions. The neutral lock adjustment bolts (D) are used to position the pintle arms in the neutral range.
 - Each neutral lock adjustment bolt has a jam nut (E). Always hold bolt (D) with a second wrench when loosening or tightening jam nut (E) so pintle arm positions are not lost.
6. Loosen jam nuts on bolts (D) and turn bolts in and out to find the neutral position of each pintle arm, that is, the position where drive wheels are not turning. Finger tighten bolts (D) against pintle arms.



FOLLOW ADJUSTMENT PROCEDURE

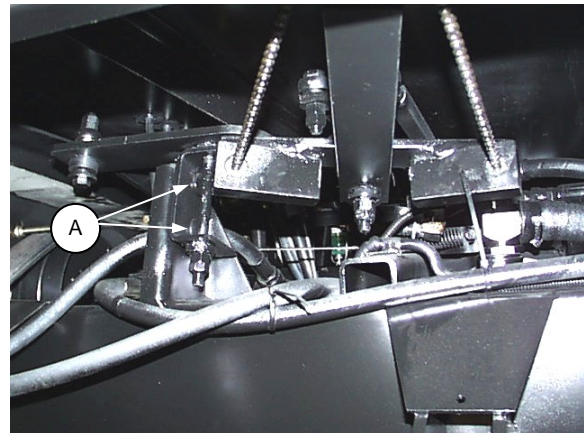

STEERING CONTROLS

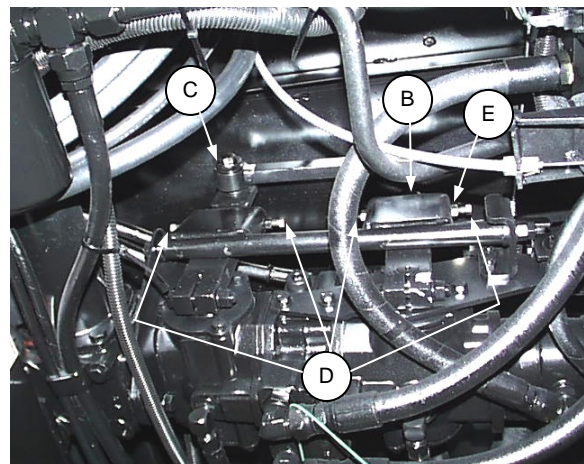

NEUTRAL LOCK

MAINTENANCE/SERVICE

Traction Drive: Neutral Set-Up Procedure (continued)

7. The following adjustment is designed to give the maximum clearance between the neutral lock adjustment bolts and the pintle arms without having the wheels turn. This results in easy locking of the steering wheel into the neutral position.

Perform this adjustment for each of the four neutral lock adjustment bolts, starting at the rear bolt and working towards the front. **Remember:** Rear pintle arm controls left wheel, front pintle arm controls right wheel.

- Have a second person grasp the front steering pivot (F) and continuously rotate it back and forth while you slowly turn adjustment bolt counter-clockwise (away from pintle arm). Find the maximum clearance position without having the wheel turn.
 - Hold bolt with a wrench and tighten jam nut to secure the position.
 - Repeat clearance adjustment until all four bolts are properly positioned.
8. Shut off engine and remove key.
9. Adjust ground speed lever to center of neutral detent. See Check #7 on page 99.
10. Repeat steps 5 to 9 if required.
11. Lower drive wheels to ground.

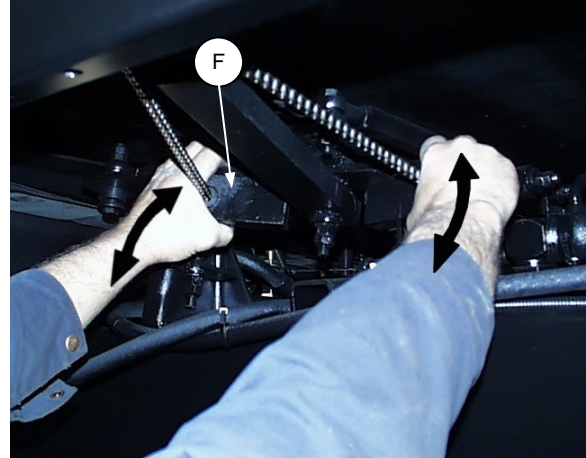

NEUTRAL LOCK ADJUSTMENT BOLTS
CLEARANCE ADJUSTMENT

MAINTENANCE/SERVICE

Traction Drive: Ground Speed Lever Friction Device Adjustment

The ground speed lever friction device maintains lever position at the point in the forward/reverse slot where it was released by the operator.

The friction device is located at the bottom of the ground speed lever (A), under the cab. It has been factory set as shown, where lock nut (B) is 0 to 1/8 inch (0 to 3 mm) from the end of the carriage bolt.

If the lever does not maintain its position in hilly or soft-soil conditions it may be desirable to increase the holding ability of the friction device.

NOTE: Increasing the holding ability of the friction device also increases the amount of force required by the operator to move the ground speed lever.

To increase friction device holding ability:

1. Tighten nut (C) until it "bottoms-out" on the threads at point (D).
2. Hold nut (C) with a wrench and tighten lock nut (B) against nut (C). Torque nut (B) to 60 - 70 ft.lbs. (80 - 90 N·m)

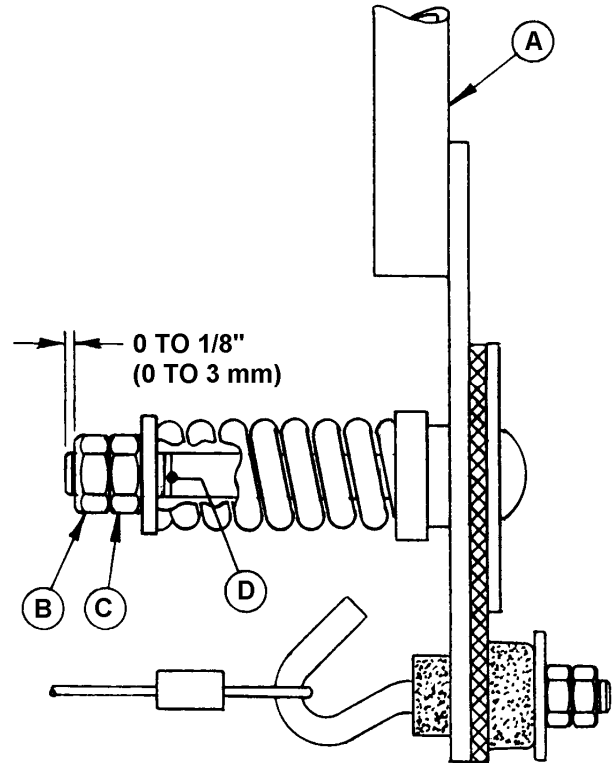

GROUND SPEED LEVER FRICTION DEVICE
(REAR VIEW)

MAINTENANCE/SERVICE

Traction Drive: Wheels and Tires

POWER HUBS

Check lubricant level every 200 hours or annually. See "Fuels, Fluids and Lubricants" for recommended lubricant.

Plugs (D) are located at 90° around wheel. To check level, position wheel so plugs (D) are at the 12 o'clock (fill) and 3 o'clock (level) positions. Lubricant should be level with plug at 3 o'clock.

Change power hub lubricant after the first 50 hours operation and every 2000 hours (or annually) thereafter. To drain lubricant, position wheel so drain plug is at 6 o'clock position. Remove level and drain plugs.

Power Hub Capacity
60 U.S. oz. (1800 mL)

IMPORTANT: Failure to disengage final drives before towing will result in serious transmission damage.

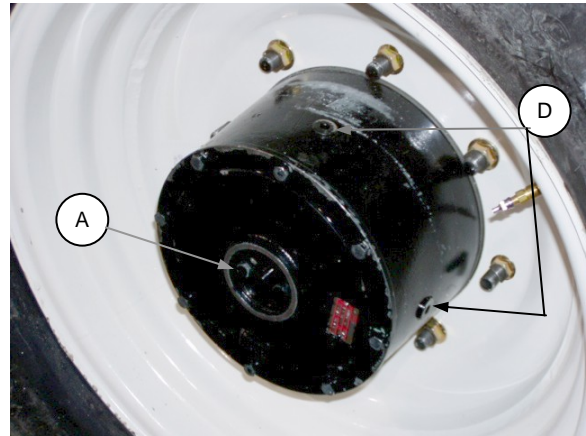

POWER HUB



CAUTION: With final drives disengaged, the windrower may roll on a sloped surface. Before disengaging final drives, attach windrower to towing vehicle. After towing, engage drives and lock steering wheel to engage park brake before detaching from towing vehicle.

To disengage final drives, remove cover (A) (both wheels) and reverse. Install with dished button facing in. After towing, reverse covers again to re-engage final drives. See "Towing the Windrower".

MAINTENANCE/SERVICE

Traction Drive: Wheels and Tires (continued)

DRIVE WHEEL BOLTS

At first use, or when a wheel is removed, check drive wheel bolt torque according to the following schedule:

- Every 15 minutes on the road or 60 minutes in the field until torque stabilizes, then
- Daily (10 hours) until no change is recorded for 3 consecutive days (30 hours), then
- Every 200 hours or annually thereafter.

Torque Specification for drive wheels:

180 ft.lbs. (245 N·m). Torque in numbered sequence shown at right. Repeat sequence three times.

NOTE: When installing drive tires, be sure air valves are on the outside and tire tread points forward.

For "Turf and Field" tires (diamond or rectangular tread), be sure arrow on sidewall points in forward rotation.

CASTER WHEEL BOLTS

Check caster wheel bolt torque after the first 5 hours and every 200 hours or annually thereafter.

Torque specification for caster wheels:

16.5L-16.1, 11-16 or 7.5-16: 100 ft.lbs. (135 N·m)

Whenever a wheel is removed and re-installed, check torque after one hour of operation.

IMPORTANT: To prevent damage to wheel disc, do not over-tighten wheel nuts.

Follow the proper bolt tightening sequence shown at right.

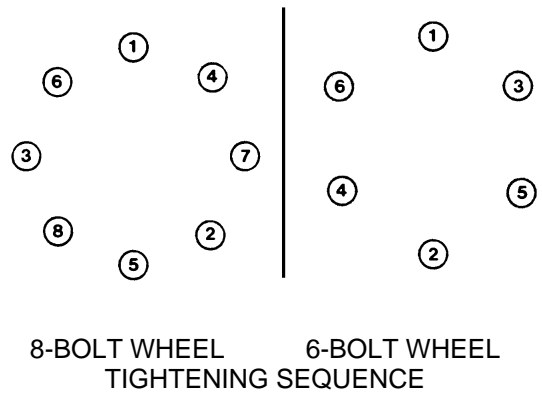

MAINTENANCE/SERVICE

Traction Drive: Wheels and Tires

TIRE INFLATION

Make a visual check daily that tires have not lost pressure. Under-inflation of drive tires can cause side wall cracks.

Once a year, measure tire pressure with a gauge. Maintain the pressures recommended on page 12 (Specifications Section).



WARNING: Service tires safely. A tire can explode during inflation and cause serious injury or death. Never increase air pressure beyond 35 psi (240 kPa) when seating the bead on the rim. Replace a tire if it has a defect. Replace a wheel rim which has cracks, wear or severe rust. Never install a tube in a cracked wheel rim. Never weld a wheel rim. Make sure all the air is removed from a tire before removing the tire from the rim. Never use force on an inflated or partially inflated tire. Make sure the tire is correctly seated before inflating to operating pressure.

Do not remove, install or make repairs to a tire on a rim unless you have the proper equipment and experience to perform the job. Take the tire and rim to a qualified tire repair shop. If the tire is not in correct position on the rim, or if too full of air, the tire bead can loosen on one side, causing air to leak at high speed and with great force. An air leak of this nature can thrust the tire in any direction, endangering anyone in the area.

- (A) - Use a safety cage if available.
- (B) - Do not stand over tire. Use a clip-on chuck and extension hose.

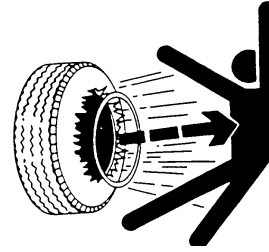

SERVICE TIRES SAFELY

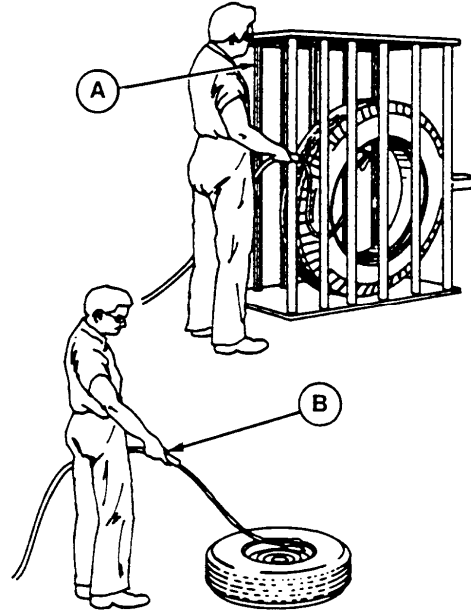

JACKING PROCEDURE

Position jack or jack stand under bracket (C) welded to tractor frame legs, ensuring head of jack is secured by keeper rod.



JACK POSITION

SHORTENING THE WHEEL BASE

The tractor unit's wheel base can be shortened from 128 inches (3244 mm) to 113 inches (2864 mm) by reversing the walking beam. This work should be done by a qualified dealer.

MAINTENANCE/SERVICE

Cab Air System



WARNING: The air conditioning system is pressurized. Improper servicing may cause refrigerant to penetrate eyes and skin or cause burns. Special equipment and procedures are required to service the air conditioning system. See your Windrower dealer for service. If an accident involving refrigerant should occur, see a doctor familiar with this type of injury immediately.

CAB TEMPERATURE CONTROLS

See "Operator's Station" section for information regarding the use of the various controls affecting cab temperature.

AIR CONDITIONING CONDENSER

Clean daily with compressed air. See "Screens and Coolers" under cooling system maintenance.

FRESH AIR INTAKE FILTER

Clean daily as follows:

1. Loosen knob (A) and slide retainer out to release filter (B) from rear of cab roof.
2. Tap filter gently on a flat surface, dirty side down. Do not tap on a tire, treads may damage filter pleats.
3. Direct compressed air (100 psi [700 kPa] maximum) through filter in opposite direction of air flow arrows.
4. Wash filter as required:
 - Soak 15 minutes in warm water (not over 100°F [40°C]) with Filter Element Cleaner, (Donaldson D 1400 or equivalent).
 - Rinse thoroughly with clean water, (maximum pressure 40 psi [275 kPa]).
 - Shake excessive water from filter and allow element to dry. Do not use compressed air to dry filter; it may rupture the wet element. Protect element from freezing until dry.
5. Reinstall filter, making sure air flow arrows point towards cab.



CAUTION: The standard cab air intake filter is not designed to filter out harmful chemicals. Follow the chemical manufacturer's instructions carefully when operating around spray areas. For use with the MacDon Sprayer, a replacement charcoal filter is provided.

NOTE:

1. The refrigerant utilized in this machine is R134a. Total system refrigerant capacity is 1.36 kg (3 lbs.). The compressor oil is SP-15 PAG. Total system oil requirement is 240 cc (8.1 U.S. fl.oz.). This amount of oil is included in a new compressor. To prevent premature system failure, do not use refrigerant R12 and/or its oil. Use of improper refrigerant or oil voids warranty.
2. Service must be performed by a qualified R134a technician only.

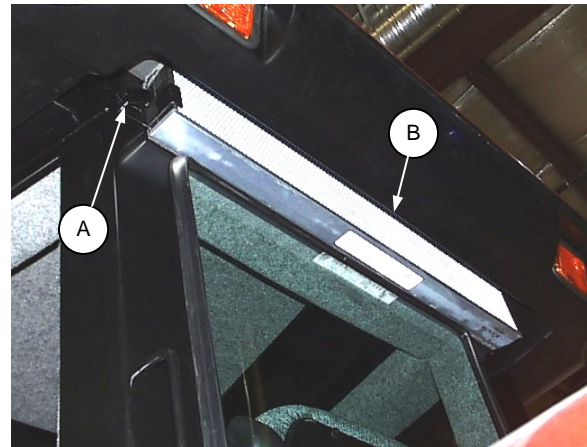

CAB FRESH AIR INTAKE FILTER



CLEANING AIR FILTER

MAINTENANCE/SERVICE

Cab Air System

RETURN AIR FILTERS

Clean return air filters every 100 hours, more often in dusty conditions.

To clean:

1. Remove filter covers at both sides of cab rear wall by removing two nuts (A).
2. Remove foam filter elements and clean with compressed air.
3. Replace filter elements and covers.



REMOVE FOR ACCESS TO
RETURN AIR FILTER

EVAPORATOR CORE

If air conditioning system produces insufficient cooling, a possible cause is clogged evaporator fins. Fins will clog up starting at the back side of the evaporator core (against cab wall).

Evaporator core access and cleaning:

1. Remove R/H console side panel (A).
2. Remove nut securing seat support panel to mount on door side.
3. Release air suspension to fully lower operator's seat. Tilt seat (B) forward while tilting seat-back (C) rearward until seat is vertical.
4. Lift the acoustical foam (E) at top of evaporator core and remove two nuts securing retainer (F). Remove retainer.
5. Tilt evaporator core forward and vacuum off back side of core (at cab wall). Use a fin straightener to loosen clogs.
6. Blow compressed air through core at an angle parallel to tubing alignment as shown. To prevent fin damage, blow air directly at fin edges, not at flat face.
7. If the compressed air can not be felt at the back of the core, proceed as follows:
 - Remove foam filter (D) from drain tray and clean with warm water.
 - With filter (D) still out, pour warm water down through the core and leave it to soak. (The drain tray will catch and remove run-off.)
8. Blow compressed air through the core as in step 6. Repeat warm water soaking as required until air blows through evaporator core freely.
9. Straighten any bent fins and reassemble.



WARNING: To avoid cuts from evaporator fins, do not use bare hands to brush away clogs.

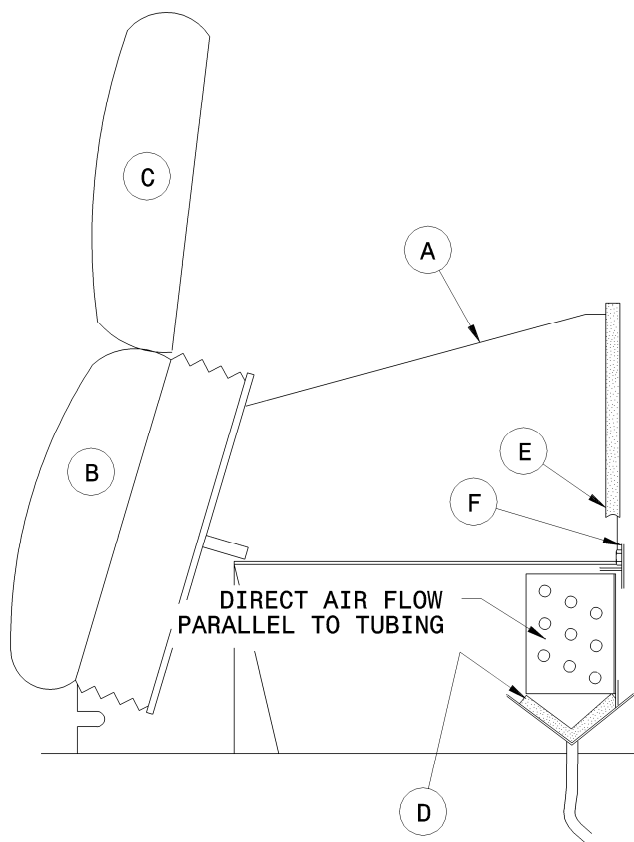

EVAPORATOR CORE ACCESS & CLEANING

MAINTENANCE/SERVICE

Cab Air System

COMPRESSOR PROTECTION

The compressor is protected from excessively low suction and high discharge pressures by two switches:

- Low suction pressure switch is located at the outlet of the evaporator (under seat in cab). It will close when the pressure drops below 4±2 psi and re-open when pressure rises above 20±5 psi.
- High discharge pressure switch is located on the receiver drier (rear of tractor, behind right side panel). It will close if pressure exceeds 325±10 psi and re-open when pressure drops below 250±30 psi.

To prevent damage to the compressor, if the air conditioning system is shut down by either switch, locate the source of the problem and correct it before operating the system.

REFRIGERANT OIL

Whenever the machine is first started after storage for more than one week: Turn blower switch to "OFF" and turn A/C temperature control switch to maximum cooling. Start engine and operate at low idle. Click blower switch from "OFF" to "LOW" for one second, then back to "OFF" for 5 to 10 seconds. Repeat this cycle ten times to distribute the oil throughout the system.

LOW SIDE PRESSURE	HIGH SIDE PRESSURE	POSSIBLE CAUSE
VERY LOW	VERY LOW	Lack of R134a
LOW	LOW	Loss of R134a Restriction between condenser and drier
LOW	LOW OR NORMAL	Restriction between drier and expansion valve Expansion valve plugged Expansion valve stuck closed Inoperative blower motor Plugged filter or evaporator core Moisture in system Defective temperature control switch Restriction at expansion valve Restriction in evaporator Restriction between evaporator and compressor suction
HIGH	LOW	Compressor belt slipping Magnetic clutch slipping Compressor internal failure
HIGH	HIGH	Condenser malfunction Condenser coil plugged Expansion valve stuck open Restriction between compressor and condenser Restriction inside condenser Overcharge of refrigerant Air in system
HIGH	NORMAL	Expansion valve stuck open
NORMAL	HIGH	Restriction between compressor and condenser Restriction inside condenser Overcharge of refrigerant
LOW	HIGH	Restriction between compressor and condenser Restriction inside condenser

NOTE: Service ports are located on suction and discharge hoses at compressor.

MAINTENANCE/SERVICE

Maintenance Schedule

The following maintenance schedule is a listing of periodic maintenance procedures, organized by service intervals. For detailed instruction, see the specific heading in Maintenance/Service section. Use "Fuels, Fluids and Lubricants" as specified under that heading.

SERVICE INTERVALS

The recommended service intervals are in hours of operation. Use the hour meter in the cab to indicate when the next service interval has been reached.

IMPORTANT: Recommended intervals are for average conditions. Service windrower more often if operated under adverse conditions (severe dust, extra heavy loads, etc.). Regular maintenance is the best insurance against early wear and untimely breakdowns. Following this schedule will increase machine life.

Where a service interval is given in more than one time frame, eg. "100 Hours or Annually", service the windrower at whichever interval is reached first.



CAUTION: Carefully follow safety messages given under "Service Procedures".

AT FIRST USE:

See "Break-In Period" in Operation section.

10 HOURS OR DAILY

1. Grease transmission driveline slip-joint.
2. Check tire inflation.
3. Check engine oil level.
4. Check engine coolant level at reserve tank.
5. Clean radiator, hydraulic oil cooler, and A/C condenser.
6. Clean cab fresh air intake filter.
7. Check hydraulic oil level.
8. Check air cleaner restriction gauge. Clean element when indicated.
9. Fill fuel tank.
10. Check fuel sediment bowl, clean if necessary.
11. Drain fuel filter water trap - diesel engine.

50 HOURS

1. Grease driveline.
2. Grease caster pivots
3. Grease header drive pulley.
4. Grease header clutch pivot.
5. Grease transmission driveline u-joints.
6. Grease walking beam center pivot.
7. Grease top lift link rear pivot.
8. Grease forked caster spindle bearings. (16.5 tire only)

MAINTENANCE/SERVICE

Maintenance Schedule

100 HOURS OR ANNUALLY *

1. Clean cab return air filters.

200 HOURS OR ANNUALLY*

1. Change bevel gear box oil.
2. Check power hub lubricant level.
3. Grease caster wheel hub bearings.
4. Check wheel bolt/nut torque.

ANNUALLY*

1. Change fuel tank vent line filter.
2. Check battery fluid level.
3. Check battery charge.
4. Check anti-freeze concentration.
5. Cycle blower switch to distribute A/C refrigerant oil.

END OF SEASON: See "Storage Procedure" in Operation section.

300 HOURS

1. Change hydraulic oil filters.

500 HOURS

1. Change engine oil and filter.
2. Change fuel filters.
3. Clean fuel feed pump strainer.

1000 HOURS OR 3 YEARS

1. Change engine air cleaner filter element.
2. Check engine valve tappet clearance.

2000 HOURS

1. Change hydraulic oil.
2. Change power hub oil. (2000 Hours or Annually*)
3. Change engine coolant.
4. General engine inspection.

*It is recommended that Annual Maintenance be done prior to start of operating season.

MAINTENANCE RECORD

Windrower Tractor Serial No. _____

Combine this record with Header Maintenance Record for complete unit service.
See Maintenance/Service section for details on each procedure. Copy these pages to continue record.

ACTION:	✓ - Check	⬇ - Lubricate	▲ - Change	* - Clean	+ - Add																		
Engine Hour Meter Reading:																							
Serviced By:																							
Maintenance Procedure																							
BREAK-IN	See "Break-In Period" in Operation section for checklist.																						
10 HOURS OR DAILY																							
⬇	Trans. Driveline Slip-Joint																						
✓	Tire Pressure																						
✓	Engine Oil Lines																						
✓	Engine Coolant																						
*	Screens/Coolers																						
*	Cab Fresh Air Filter																						
✓	Hydraulic Oil																						
✓	Air Cleaner Restr. Gauge																						
+	Refuel																						
✓	Fuel Sediment Bowl																						
✓	Fuel Filter Water Trap																						
50 HOURS																							
⬇	Driveline																						
⬇	Header Drive Pulley																						
⬇	Header Clutch Pivot																						
⬇	Trans. Driveline U-Joints																						
⬇	Walking Beam Pivot																						
⬇	Lift Link Rear Pivot																						
⬇	Caster Pivots																						
⬇	Forked Caster Bearings																						
100 HOURS OR ANNUALLY																							
*	Cab Return Air Filters																						
200 HOURS OR ANNUALLY																							
▲	Bevel Gear Box Oil																						
✓	Power Hub Lube Level																						
⬇	Caster Wheel Hub Bearings																						
✓	Wheel Bolt Torque																						
ANNUALLY																							
▲	Fuel Tank Vent Filter																						
✓	Battery Fluid																						
✓	Battery Charge																						
✓	Anti-Freeze																						
✓	A/C Refrigerant Oil																						
	Storage Procedure	See "Storage Procedure" in Operation section for checklist																					
CONTINUED NEXT PAGE																							

MAINTENANCE RECORD (continued)

ACTION:	✓ - Check	⬇ - Lubricate	▲ - Change	* - Clean	+ - Add
Engine Hour Meter Reading:					
Serviced By:					
Maintenance Procedure					
300 HOURS					
▲ Hydraulic Oil Filters					
500 HOURS					
▲ Engine Oil & Filter					
▲ Fuel Filters					
* Fuel Feed Pump Strainer					
1000 HOURS OR 3 YEARS					
▲ Air Cleaner Element					
✓ Valve Tappets					
2000 HOURS					
▲ Hydraulic Oil					
▲ Power Hub Oil (or yearly)					
▲ Engine Coolant					
✓ General Engine Inspection					

TROUBLE SHOOTING

<u>SYMPTOM</u>	<u>PROBLEM</u>	<u>SOLUTION</u>	<u>REF.</u>
Cab Air System	See page 109 for possible causes of abnormal high side / low side pressure.		
Blower fan will not run.	Burned out motor.	Replace motor.	*
	Burned out switch.	Replace switch.	*
	Motor shaft tight or bearings worn.	Repair motor.	*
	Faulty wiring - loose or broken.	Repair or replace wiring.	*
	Blower rotors in contact with housing.	Replace rotors and/or housing.	*
Blower fan operating but no air coming into cab.	Dirty fresh air filter.	Clean filter.	107
	Evaporator clogged.	Clean evaporator.	108
	Air flow passage blocked.	Remove blockage.	---
Heater not heating.	Heater shut-off valve at engine closed.	Open valve.	21
	Defective thermostat in engine water outlet manifold.	Replace thermostat.	*
	Heater temperature control defective.	Replace control.	*
	No thermostat in engine water outlet manifold.	Install thermostat.	*
Odour from air louvers.	Plugged drainage hose.	Blow out hose with compressed air.	---
	Dirty filters.	Clean filters.	107, 108
Air conditioning not cooling.	Low refrigerant level.	Add refrigerant	*
	Switch contacts in thermostat burned excessively, or sensing element defective.	Replace thermostat.	*
	Clutch coil or relay burned out or disconnected.	Check current flow to clutch or relay. Replace if inoperative.	*
	Condenser fins plugged.	Clean condenser.	79
	Blower motor disconnected or burned out.	Check current flow to blower motor. Repair or replace if inoperative.	*

* See your Windrower Dealer.

TROUBLE SHOOTING

<u>SYMPTOM</u>	<u>PROBLEM</u>	<u>SOLUTION</u>	<u>REF.</u>
Air conditioning not cooling. (continued)	Loose or broken drive belt.	Replace drive belt and/or tighten to specs.	66
	Compressor partially or completely seized.	Remove compressor for service or replacement.	*
	Dirty filters.	Clean fresh air and re-circulation filters.	107, 108
	Broken or disconnected electrical wire.	Check all terminals for loose connections; check wiring for hidden breaks.	---
	Broken or disconnected ground wire.	Check ground wire to see if loose, broken, or disconnected.	---
	Expansion valve stuck in open or closed position.	Replace expansion valve.	*
	Broken refrigerant line.	Examine all lines for evidence of breakage by external stress or rubbing wear.	*
	Leak in system.	Leak-test system; repair leaks as necessary.	*
	Compressor shaft seal leaking.	Replace compressor shaft seal.	*
	Clogged screen in receiver-drier; plugged hose or coil.	Repair as necessary. Replace receiver-drier; evacuate and charge.	*
Air conditioning not producing sufficient cooling. (Sufficient cooling defined as when air temperature in cab, measured at louvered vent, can be maintained at 25°F (14°C) below ambient air temperature.)	Compressor clutch slipping.	Remove clutch assembly for service or replacement.	*
	Clogged air filter.	Remove air filter and clean or replace as necessary.	107
	Heater circuit is open.	Close heater valves (1 in cab, 1 at engine).	21
	Too little air circulation over condenser coil; fins clogged with dirt or insects.	Clean condenser.	78
	Evaporator fins clogged.	Clean evaporator fins (under seat)	108
	Too little refrigerant in system.	Recharge system until gauge readings stabilize to specifications.	109

* See your Windrower dealer.

TROUBLE SHOOTING

<u>SYMPTOM</u>	<u>PROBLEM</u>	<u>SOLUTION</u>	<u>REF.</u>	
Air conditioning not producing sufficient cooling (continued).	Clogged expansion valve.	Recover system refrigerant and replace valve. Then, evacuate and charge system.	*	
	Clogged receiver-drier.	Recover system refrigerant and replace receiver-drier. Then evacuate and charge system.	*	
	Excessive moisture in system.	Recover system refrigerant and replace receiver-drier. Then evacuate and charge system.	*	
	Air in system.	Recover refrigerant, evacuate and charge system.	*	
	Thermostat defective or improperly adjusted.	Replace thermostat.	*	
	Blower motor sluggish in operation.	Remove motor for service/replacement.	*	
	Air conditioning system too noisy.	Defective winding or improper connection in compressor clutch coil or relay.	Repair or replace as necessary.	*
		Loose or excessively worn drive belt.	Tighten or replace as required.	66
		Noisy clutch.	Remove clutch for service or replacement as required.	*
		Noisy compressor.	Check mountings and repair. Remove compressor for service or replacement.	*
Compressor oil level low.		Add SP-15 PAG refrigerant oil.	*	
Blower fan noisy due to excessive wear.		Remove blower motor for service or replacement as necessary.	*	
Excessive charge in system.		Discharge excess refrigerant until pressure drops within specs. (Always recover discharged refrigerant.)	*	
Low charge in system.		Check system for leaks, charge system.		

* See your Windrower dealer.

TROUBLE SHOOTING

<u>SYMPTOM</u>	<u>PROBLEM</u>	<u>SOLUTION</u>	<u>REF.</u>
Air conditioning system too noisy. (continued)	Excessive moisture in system.	Replace receiver-drier, evacuate & charge system.	*
Air conditioning cools intermittently.	Compressor clutch slipping.	Slippage over a prolonged period will require removing clutch for service. May require adjustment for proper spacing.	*
	Unit icing up due to: · thermostat adjusted too low. · excessive moisture in system. · incorrect super-heat adjustment in expansion valve.	· Adjust thermostat. · Replace receiver-drier. · Replace expansion valve.	*
	Thermostat defective.	Replace thermostat.	*
	Defective blower switch or blower motor.	Remove defective part for service or replace.	*
	Partially open, improper ground, or loose connection in compressor clutch coil.	Check connections or remove clutch coil for service or replacement.	*
Windows fog up.	High humidity.	Run A/C to dehumidify air <u>and</u> heater to control temperature.	21

Engine

Engine hard to start or will not start.	Controls not in neutral.	<ul style="list-style-type: none"> • Move variable speed lever to neutral. • Move steering wheel to locked position. • Disengage header clutch. 	32
	Header drive idler not pivoted against stop to close neutral switch.	Remove key from ignition. From under tractor, push up on idler to complete pivot travel, closing neutral switch.	97
	Neutral lock misadjusted.	Check neutral lock.	97
	No fuel to engine.	Fill empty fuel tank, replace clogged filter.	70
	Old fuel in tank.	Drain tank, refill with fresh fuel.	70

* See your Windrower dealer.

TROUBLE SHOOTING

<u>SYMPTOM</u>	<u>PROBLEM</u>	<u>SOLUTION</u>	<u>REF.</u>
Engine hard to start or will not start. (cont'd)	Water, dirt or air in fuel system.	Drain, flush, fill and bleed system.	73
	Improper type of fuel.	Use proper fuel for operating conditions.	59
	Crankcase oil too heavy.	Use recommended oil.	60
	Low battery output.	Have battery tested. Check battery electrolyte level.	80
	Poor battery connection.	Clean and tighten loose connections.	80
	Faulty starter.	Repair or replace.	*
	Wiring shorted, circuit breaker open.	Check continuity of wiring and breaker (manual reset).	87
	Faulty injectors.	Clean or replace injectors.	*
Engine knocks.	Insufficient oil.	Add oil.	65
	Engine out of time.	Time injection pump.	*
	Low or high coolant temperature.	Remove and check thermostat. See "Engine Overheats".	*
Low oil pressure.	Improper fuel.	Use proper fuel.	59
	Low oil level.	Add oil.	65
	Improper type of oil.	Drain, fill crankcase with proper oil.	60
High oil consumption.	Worn components.	Repair engine.	*
	Crankcase oil too light.	Use recommended oil.	60
	Oil leaks.	Check for leaks around gaskets, seals, and drain plugs.	---
	Internal parts worn.	Check for worn parts.	*

* See your Windrower dealer.

TROUBLE SHOOTING

<u>SYMPTOM</u>	<u>PROBLEM</u>	<u>SOLUTION</u>	<u>REF.</u>
Engine runs irregularly or stalls frequently.	Unsteady fuel supply.	Change filter on fuel tank vent line. Replace clogged fuel filter.	70
	Water, dirt or air in fuel system.	Drain, flush, fill and bleed system.	73
	Low coolant temperature.	Remove and check thermostat.	*
	Dirty or faulty injectors.	Clean or replace injectors.	*
	Engine electrical faults	Check fuses and electrical connections at engine	
Lack of power.	Incorrect timing.	Time injection pump.	*
	Engine oil viscosity too high.	Use recommended oil.	60
	Intake air restriction.	Service air cleaner.	68
	Clogged fuel filter.	Replace fuel filter.	72
	High back pressure.	Clean out muffler (N.A. engine).	75
	Improper type of fuel.	Use proper fuel.	59
	High or low engine temperature.	Remove and check thermostat. See "Engine Overheats".	*
	Improper valve clearance.	Set valve clearance.	*
	Faulty injectors.	Clean or replace injectors.	*
Engine temperature below normal.	Defective thermostat.	Remove and check thermostat.	*

* See your Windrower dealer.

TROUBLE SHOOTING

<u>SYMPTOM</u>	<u>PROBLEM</u>	<u>SOLUTION</u>	<u>REF.</u>
Warning alarm sounds.	Engine overheated.	Check coolant level and thermostat.	76
	Low engine oil pressure.	Check oil level.	65
	Low transmission oil pressure.	Check oil level.	88
Engine overheats.	Low coolant level.	Fill reserve tank to proper level. Check system for leaks.	76
	Engine overloaded.	Reduce ground speed.	35
	Defective radiator cap.	Replace cap.	76
	Defective fan belt.	Replace belt.	66
	Dirty radiator screen:		
	• Rotors turning	• Check for obstructions in ducting from screen to fan shroud.	---
	• Rotors not turning	• Check connections to rotor electric motor.	---
	Dirty radiator core.	Clean radiator.	78
	Cooling system dirty.	Flush cooling system.	77
	Defective thermostat.	Remove and check thermostat.	*
Defective temperature gauge or sender.	Check coolant temperature with thermometer, replace if necessary.	*	
Defective water pump.	Repair or replace.	*	
Water only for coolant.	Use antifreeze.	76	
High fuel consumption.	Improper type of fuel.	Use proper fuel.	59
	Clogged or dirty air cleaner.	Service air cleaner.	68
	Engine overloaded.	Reduce ground speed.	35
	Improper valve clearance.	Reset valves.	*

* See your Windrower dealer

TROUBLE SHOOTING

<u>SYMPTOM</u>	<u>PROBLEM</u>	<u>SOLUTION</u>	<u>REF.</u>
High fuel consumption (continued).	Engine out of time.	Time injection pump.	*
	Low engine temperature.	Check thermostat.	*
	Injection nozzles dirty.	Clean or replace injectors.	*
Engine emits black or grey exhaust.	Improper type of fuel.	Consult your fuel supplier and use proper type fuel for conditions.	59
	Engine overloaded.	Reduce ground speed.	35
	Clogged or dirty air cleaner.	Service air cleaner.	68
	Defective muffler.	Check muffler for possible damage which might create back pressure.	75
	Dirty or faulty injectors.	Clean or replace injectors.	*
	Engine out of time.	Time injection pump.	*
	Air in fuel system.	Bleed fuel system.	73
Engine emits white exhaust.	Improper type of fuel.	Consult your fuel supplier and use proper type fuel for conditions.	59
	Cool engine.	Warm engine up to normal operating temperature.	33
	Defective thermostat.	Remove and check thermostat.	*
	Engine out of time.	Time injection pump.	*
Starter cranks slowly or will not operate.	Low battery output.	Check battery charge.	80
	Controls not in neutral.	<ul style="list-style-type: none"> • Move variable speed lever to neutral. • Move steering wheel to center position. • Disengage header clutch. 	32
	Cylinder for engaging header drive belt not retracted.	Determine cause of cylinder malfunction and repair.	*

* See your Windrower dealer.

TROUBLE SHOOTING

<u>SYMPTOM</u>	<u>PROBLEM</u>	<u>SOLUTION</u>	<u>REF.</u>
Starter cranks slowly or will not operate (cont'd)	Relay not functioning.	Check relay and wire connections.	*
	Loose or corroded battery connections.	Clean and tighten loose connections.	80
	Key switch worn or terminals loose.	Check switch and terminals.	*
	Crankcase oil too high viscosity.	Use recommended oil.	60
	Main circuit breaker tripped.	Reset main circuit breaker.	87
	Main circuit breaker defective.	Replace circuit breaker.	*
Air filters require frequent cleaning.	Vacuator plugged.	Clean out vacuator.	68
	Pre-cleaner rotor not turning freely.	Repair/replace.	*

Electrical

Low voltage and/or battery will not charge.	Defective battery.	Have battery tested.	*
	Defective alternator belt.	Replace worn belt.	66
	Loose or corroded connections.	Clean and tighten battery connections.	80
	Dirty or defective alternator, defective voltage regulator, or high resistance in circuit.	Check circuit.	*
	Alternator or voltage regulator not connected properly.	Connect properly.	82
Lights dim.	High resistance in circuit or poor ground on lights.	Check the wiring circuit for a break in a wire or a poor ground.	*
	Defective light switch.	Replace switch.	*

* See your Windrower dealer.

TROUBLE SHOOTING

<u>SYMPTOM</u>	<u>PROBLEM</u>	<u>SOLUTION</u>	<u>REF.</u>
Lights do not light.	Defective light switch.	Replace switch.	*
	Broken wiring; open or defective circuit breaker.	Check wiring for broken wire or shorts, check circuit breaker.	87
	Defective relay.	Replace relay.	*
	Poor ground on lights.	Clean and tighten ground wires.	---
Turn signals or indicators showing wrong direction.	Reversed wires.	Connect properly.	*
No current to cab.	Main circuit breaker tripped.	Reset main breaker.	87
	Broken or disconnected wire.	Check wiring for a broken, loose or shorted wire.	*

Traction Drive System

Warning alarm sounds and transmission oil light is on.	Low hydraulic oil level.	Stop engine, add oil.	88
	Low hydraulic pressure.	Check and replace check valve if defective.	96
	Foreign material shorting sender.	Clean top of sender.	---
	Short in alarm wiring.	Check wiring to alarm.	*
	Faulty sender.	Replace sender.	*
Wheels lack pulling ability on a grade or pulling out of a ditch.	Insufficient torque at drive wheels.	Turbo - Move speed-range control to field position and reduce ground speed.	35
	Loose or worn controls.	Check controls.	*
	Air in system.	Use proper oil, check oil level, check oil filter and leaks.	88
	Brakes binding or not releasing fully.	Check pressure (min. 200 psi on brake release valve).	*
	Internal pump or motor damage.	Check pump and/or motor.	*
	Relief valve in tandem pump dirty or damaged.	Replace relief valve.	*

* See your Windrower dealer.

TROUBLE SHOOTING

<u>SYMPTOM</u>	<u>PROBLEM</u>	<u>SOLUTION</u>	<u>REF.</u>
Both wheels will not pull in forward or reverse.	Low oil level.	Check oil reservoir level.	88
	Power hubs disengaged.	Engage power hubs.	104
	Damaged hydraulic lines preventing proper oil flow.	Replace damaged lines.	*
	Steering controls worn or defective.	Check variable speed lever and steering for loose, worn or damaged ball joints and connecting rods.	*
	Speed-range control not working.	Check speed-range wiring. Check for faulty servo or blockage in hose.	*
	Pump arms have broken shaft or loose hardware.	Repair or tighten.	*
	Brakes binding or not releasing fully.	Check pressure (min. 200 psi on brake release valve.	*
	Charge pressure relief valve misadjusted or damaged.	Check the valve adjustment. Check valve parts and seat.	*
One wheel does not pull in forward or reverse.	Failed pump or motor.	Repair or replace pump or motor.	*
	One power hub disengaged.	Engage power hub.	104
	Pump arm or shaft are broken.	Replace arm or shaft.	*
	Steering controls worn or defective.	Check variable speed lever and steering for loose, worn or damaged ball joints and connecting rods.	*
	Damaged hydraulic lines preventing proper oil flow.	Replace damaged lines.	*
	Brakes binding or not releasing fully.	Check pressure (min. 200 psi on brake release valve.	*

* See your Windrower dealer.

TROUBLE SHOOTING

<u>SYMPTOM</u>	<u>PROBLEM</u>	<u>SOLUTION</u>	<u>REF.</u>
One wheel does not pull in forward or reverse (continued).	Speed-range control not working.	Check for faulty servo or blockage in hose.	*
	High pressure relief valve stuck open, damaged seat.	Check valve and clean or replace.	*
	Failed pump, motor or power hub.	Repair or replace failed component.	*
With steering wheel centered, one wheel pulls more than the other.	Leakage at pump or motor.	Repair pump or motor.	*
	Faulty relief valve.	Repair or replace valve.	*
Excessive noise from drive system.	Hydraulic line clamps loose.	Tighten clamps.	---
	Mechanical interference in steering or ground speed linkage.	Adjust, repair, replace.	---
	Brakes binding or not releasing fully.	Check pressure (min. 200 psi on brake release valve).	*
	Faulty pump or motor.	Repair or replace pump or motor.	*
	Air in system.	Check lines for leakage.	*
Hydraulic oil filter leaks at seal.	Not properly tightened.	Tighten filter element.	---
	Damaged seal or threads.	Replace filter or filter head.	89

Steering and Ground Speed Controls

Machine will not steer straight.	Linkage worn or loose.	Replace worn parts, adjust linkage.	*
Machine moves on flat ground with controls in neutral.	Neutral lock misadjusted. See note below.	Adjust neutral lock.	97
	Parking brake not functioning.	Adjust neutral lock, check brake valve	97 *
Insufficient road speed.	Speed-range control in Field Position.	Move to Road Position.	22

NOTE: A more complete Troubleshooting guide is given for the Neutral Lock & Steering on page 100.

* See your Windrower dealer.

TROUBLE SHOOTING

<u>SYMPTOM</u>	<u>PROBLEM</u>	<u>SOLUTION</u>	<u>REF.</u>
Header Hydraulics			
Header or reel not lifting.	Contaminant in relief valve.	Clean relief valve at cylinder control valve.	90
	Appropriate solenoids not being energized by activating switch.	Check electrical connections; repair or replace solenoid(s).	*
Header or reel lifts but lacks power.	Relief pressure too low, or contaminant in relief valve.	Check/adjust/clean relief valve at cylinder control valve.	90
Reel and/or conveyor not turning.	Header drive switch not engaged.	Engage switch.	23
	Flow controls turned down too low.	Turn flow control clockwise to increase flow.	23
	Contaminant in relief valve.	Clean relief valve at flow control block.	91
	Appropriate solenoid on flow control block not being energized.	Check electrical connections; repair or replace solenoid.	*
Reel and/or conveyor turns but lacks power.	Relief pressure too low, or contaminant in relief valve.	Check/adjust/clean relief valve at flow control block.	91

Header Drive

Sickle drive not engaging.	Header drive switch in cab not engaged.	Engage switch.	23
	Tensioning cylinder front pivot bolt too tight, preventing idler bracket from rotating up to switch.	Adjust locknuts to allow free movement of cylinder ram on bolt.	---
	Rear lower belt support pivot too tight, preventing cylinder from contacting switch at front.	Adjust locknuts to allow free movement of support on pivot bolt.	95

* See your Windrower dealer

TROUBLE SHOOTING

<u>SYMPTOM</u>	<u>PROBLEM</u>	<u>SOLUTION</u>	<u>REF</u>
Header Drive			
Sickle drive not engaging (continued)	Appropriate solenoid not being energized by activating switch.	Check electrical connections; repair or replace solenoid.	*
	Header drive belt tension too low.	Check hydraulic pressure at tensioning cylinder. Should be between 150 & 250 psi.	---
		Check for plugged orifice at cylinder.	---
Sickle drive engages but lacks power.	Header drive belt tension too low.	If pressure is below 150: 1) Check charge pressure 2) Repair/replace pump	96 *
	Worn belt.	Replace belt.	92
Belt will not disengage.	Tensioning cylinder front pivot bolt too tight, preventing idler bracket from rotating away from switch.	Adjust locknuts to allow free movement of cylinder ram on bolt.	---
	Rear lower belt support pivot too tight, preventing cylinder from disengaging switch at front.	Adjust locknuts to allow free movement of support on pivot bolt.	95
	Belt has shrunk due to over-heating when disengaged, or excessive slipping when engaged.	Replace damaged or worn belt. Adjust belt guides and keepers. Check hydraulic pressure at tensioning cylinder (see above).	96
Belt vibration.	Burnt spot or band cut in one place.	Replace belt.	92
Band split full length of belt.	Misalignment of pulleys.	Replace belt and adjust pulleys.	92
Sections of band missing from belt.	Misalignment of pulleys.	Replace belt and align pulleys.	92
	Idlers not square with pulleys.	Align idlers.	93

* See your Windrower dealer.

TROUBLE SHOOTING

<u>SYMPTOM</u>	<u>PROBLEM</u>	<u>SOLUTION</u>	<u>REF</u>
Header Drive (continued)			
Belt band frayed and separated from V-belt at one side.	Belt has jumped one groove at front pulley:	Adjust pulley shield.	95
	Belt shield too far from pulley. Belt guides and shields not properly adjusted.	Adjust belt guides and keepers	95
Belt bands or sides of belt prematurely worn. Burnt paint on shields or guides.	Belt guides and keepers too close to belt.	Adjust belt guides and keepers.	95

Park Brake

Loss of brake capacity.	Worn Brake Discs		*
	Brake solenoid not energising		*
			*
Incomplete brake release.	Brake not releasing fully	Press min.(200psi) on brake release valve (Traction Charge).	*

Operator's Seat

Rough ride.	Seat suspension not adjusted for operator's weight.	Adjust seat suspension.	26
	High air pressure in tires.	Deflate to proper pressure.	12

* See your Windrower dealer.

OPTIONS AND ATTACHMENTS

Consult your Windrower dealer for details on the following Options & Attachments.

NOTE: If not factory ordered, installation of these kits is to be done by Windrower dealer.

Air Intake Screen Cleaner

WholeGoods order number: B2972

This automatic screen cleaning device "vacuums" the screen by means of two rotors.



AIR INTAKE SCREEN CLEANER

In-Frame Rear Weight Package

WholeGoods order number: B2266

For heavier headers (3000 lbs. plus, including reel) in hilly conditions, weight may be added to rear of tractor frame. One or two weight packs may be installed, as described on page 44. **NOTE:** For high clearance tractors (9352/4952/2952/8152) two of these weight packs are factory installed. If additional weight is required after installation of two in-frame weight packs, behind-frame packages are available as below:

Behind-Frame Weight Packages

400 lb. (181 kg) Package: WholeGoods order number: B2980

Additional 300 lb. (136 kg) Package: WholeGoods order number: B2981 (requires 400 lb. package be installed)

Header "Express-Down" Module

WholeGoods order number: B2964

Allows the header lift cylinders to completely retract and lower the header with only momentary activation of the header height control switch. Also includes feature by-pass switch. Installation instructions are included with the kit.

Formed Tail-Wheel Casters

Tractor Models 9352c, 4952c, 2952c, 8152c:

WholeGoods order number: B2998 – 7.5-16 tires

Auxiliary Float Spring Kit

WholeGoods order number: B2773

Required to provide adequate float for heavier headers in windrowing applications.

NOTE: 36' Double Sickle headers require four auxiliary float spring kits. See the Windrower Tractor Parts Catalog for service components of kit.

Forked Tail-Wheel Casters

Tractor Models 9352c, 4952c, 2952c, 8152c:

WholeGoods order number: B2995 – 11-16 tires
B2996 – 16.5L-16.1 tires



FORKED CASTER OPTION

Hydraulic Reel Fore-Aft Module

WholeGoods order numbers: B2960 – Base Kit*

B2961 – Fore-Aft

Provides hydraulic components and controls required to accept headers with reel fore-aft option, which allows in-cab adjustment of reel fore-aft position. Installation instructions are provided with the kit.

* - One Base Kit B2960 is required for either, or both the Hydraulic Reel Fore-Aft Module and the Hydraulic Header Tilt Module. (If both options are installed, only one base kit is required.)

Hydraulic Header Tilt Module

WholeGoods order numbers: B2960 – Base Kit*

B2962 – Header Tilt

The mechanical center link to the header is replaced with a hydraulic cylinder to allow in-cab adjustment of header tilt (angle) by means of a switch on the ground speed control handle.

Shallow Angle Kit

WholeGoods order numbers: B4482

Modifies tractor lift linkage to permit shallower header angle for rocky field conditions to prevent cutterbar damage.

Approved Radio Source:

REI (Radio Engineering Industries, Inc.)
Omaha, Nebraska
Ph. 1-800-228-9275

UNLOADING



WARNING: To avoid personal injury or death do not attempt to drive the windrower off the carrier. It must be lifted or towed. When starting the windrower, slight movement of the steering wheel could cause fast and hard-to-correct movement on a small surface such as a trailer bed. This could cause the machine to fall from the carrier onto the ground.

Prepare to Unload



CAUTION: To avoid injury to bystanders from being struck by machinery, do not allow persons to stand in the unloading area.

1. Move trailer into position and block trailer wheels.
2. Lower trailer storage stands.



CAUTION: Unloading equipment must meet or exceed the specified requirements. Using inadequate equipment may result in vehicle tipping or machine damage.



PREPARE TO UNLOAD

Two Forklift Method

FORKLIFT REQUIREMENTS: Two forklifts, each with a 5000 lb. (2270 kg) capacity and minimum 8 ft. (2.5 m) lift height.

1. Set forklift tines to the widest possible setting.
2. Position one forklift on either side of trailer bed.

NOTE: Windrower center of gravity is approximately 48 inches (1220 mm) rearward of drive wheel center.

3. Place forks under windrower frame on both sides.
4. Lift with both forklifts simultaneously until windrower is clear of trailer bed.
5. Drive truck slowly forward until trailer bed is clear of windrower.
6. Lower unit slowly and simultaneously with both forklifts to approximately 24 inches (600 mm) from ground.
7. Install front and rear tires. See "Tires" in Assembly section.
8. Lower unit to ground.

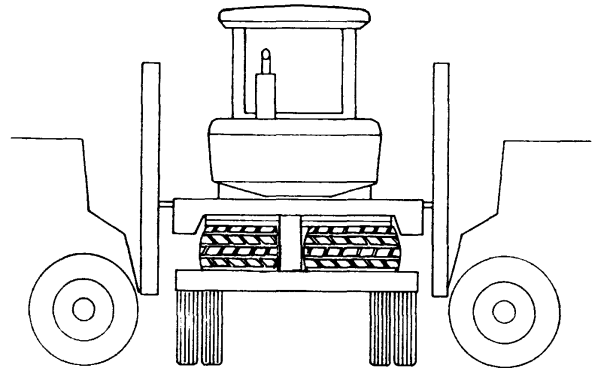

UNLOADING WITH TWO FORKLIFTS

UNLOADING

One Forklift Method

FORKLIFT REQUIREMENT: One forklift with a 5,000 lb. (2270 kg) capacity.

CHAIN REQUIREMENTS: Overhead lifting quality chain with a minimum 5000 lb. (2270 kg) working load limit.

1. Back rear of truck bed up to an unloading dock which is the same height or slightly lower than the trailer bed. Remove miscellaneous parts shipped under tractor frame.
2. Set forklift tines to the widest possible setting.
3. Drive the forklift up to the windrower from the rear and place forks under the rear frame cross member.
4. Lift rear end of windrower and remove drive wheels from under frame.
5. Install chains from forklift mast to triangular brackets (A) at rear of both windrower frame front legs. Be sure both chains are the same length.



CAUTION: The front frame legs rest on the trailer bed on skid shoes (S). Be sure there are no obstructions to prevent rearward sliding of the skid shoes and watch carefully that as unit is dragged, the skid shoes are not sliding sideways towards the side edge of the trailer bed.

6. Drag windrower rearward off of carrier.
7. Remove chains and install front and rear tires. See "Tires" in Assembly section.

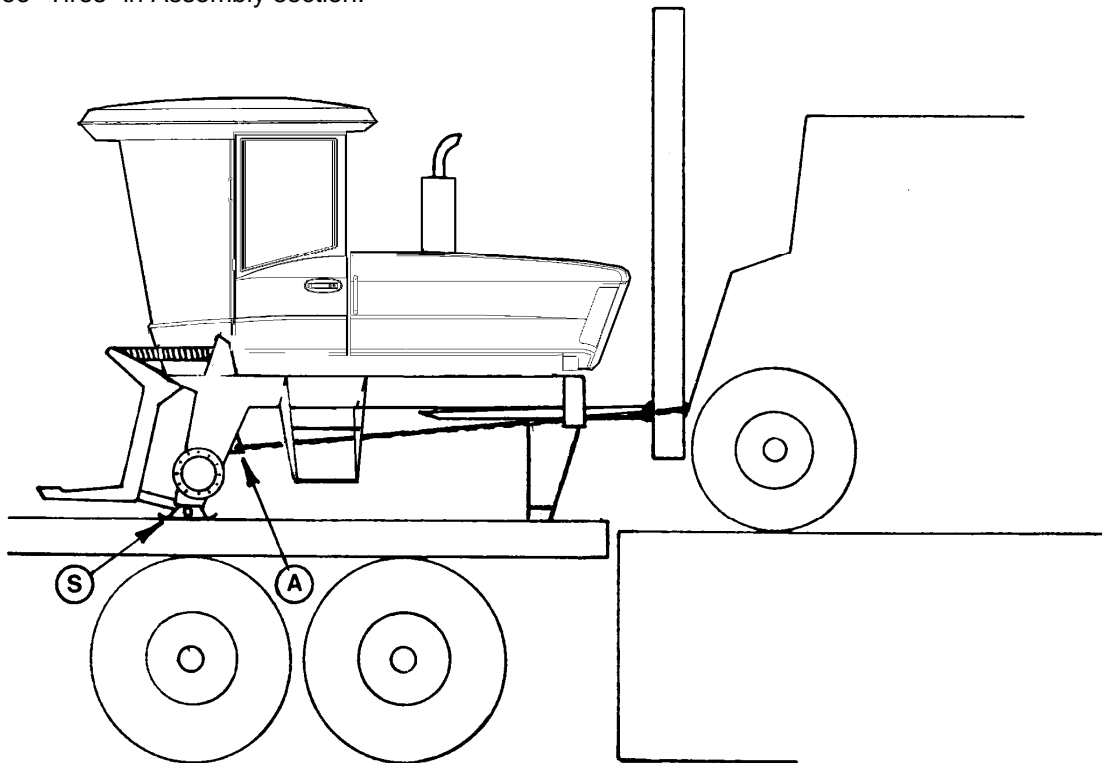

UNLOADING WITH ONE FORKLIFT

ASSEMBLY

NOTE: The purpose of shipping preparations such as having no battery is to better adapt the unit for an extended non-active period. If the machine is to remain non-active for a long period of time, do not perform the following assembly work until necessary. Also, further prepare the unit for storage as instructed in this manual.

Install Tires

16.5, 11-16 or 7.5 REAR TIRES

1. Lift rear end of windrower with forklift and remove yellow shipping support (B) from walking beam. Replace bolts securing walking beam pivot tube bracket and torque to 390 N-m (290 ft.lbs.).
2. Liberally apply multi-purpose grease to bottom surface of spring assembly (C). Install assembly (C) over caster pivot shaft.
3. Install caster (E) into walking beam by raising the caster and lowering walking beam onto pivot shaft. **NOTE:** Ensure tabs (J) on spring assembly engage slots in bottom of walking beam.
4. Grease both sides of thrust washer (F) before assembly. Place greased washer (F) onto walking beam.
5. Place cap (G) on top of washer (F) and secure with two 1/2 x 1 inch hex head bolts, and lock-washers, ensuring bolts engage threaded holes in top of caster pivot shaft. Tighten bolts to 75 ft. lbs. (102 N-m).
6. Place transport lock pin (H) into storage position and secure with hairpin.
7. Repeat steps 2 to 7 at other caster.
8. **IMPORTANT:** Grease the caster pivots with multi-purpose grease, continuing until grease is forced out top of walking beam. (This may require 60 to 70 pumps of grease gun.)
9. Place rear casters in the outboard position (extending behind walking beam) and lower windrower to ground.
10. Set caster tire pressure at 10 psi (70 kPa) for 16.5 or 11-16 tires and 19 psi (132 kPa) for 7.5 tire.

NOTE: For 16.5 and 11-16 rear tires, factory set pressures are higher than recommended operating pressure. Deflate to 10 psi.

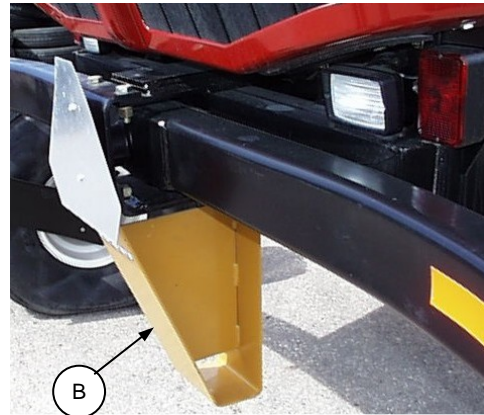

REMOVE SHIPPING SUPPORT

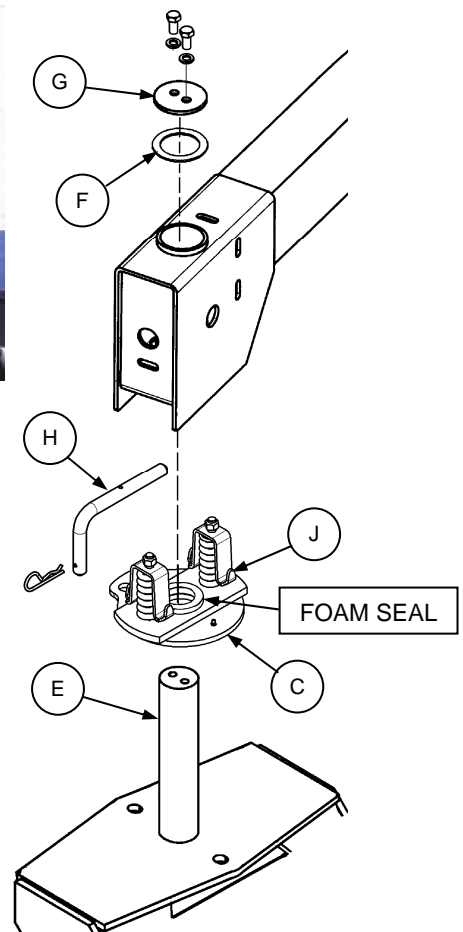
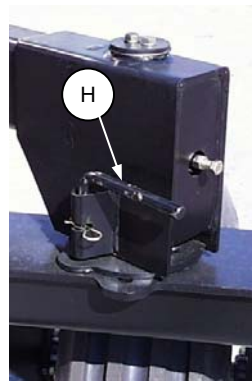

REAR CASTER INSTALLATION

ASSEMBLY

Install Tires

DRIVE TIRES

Install tires on a hard, level surface as follows:

1. Lift front end of windrower using a forklift and place 14" (35 cm) blocks under yellow skid shoes (S) on front frame legs.
2. Install drive tires onto power hubs ensuring tire tread points forward and air valve stems are on the outside.
NOTE: For "Turf and Field" tires (diamond or rectangular tread), be sure arrow on sidewall points in forward rotation.

3. Torque drive wheel bolts to **180 ft. lbs.** (245 N·m)
Follow proper bolt tightening sequence (see Maintenance/Service section). Re-check torque as follows:
 - Every 15 minutes on the road or 60 minutes in the field until torque stabilizes, then
 - Daily (10 hours) until no change is recorded for 3 consecutive days (30 hours), then
 - Every 200 hours or annually thereafter.

4. Lift front end of windrower with forklift and remove the blocks from under skid shoes. Lower the windrower onto its tires.
5. **IMPORTANT:** Remove yellow skid shoes (S) from front frame legs.

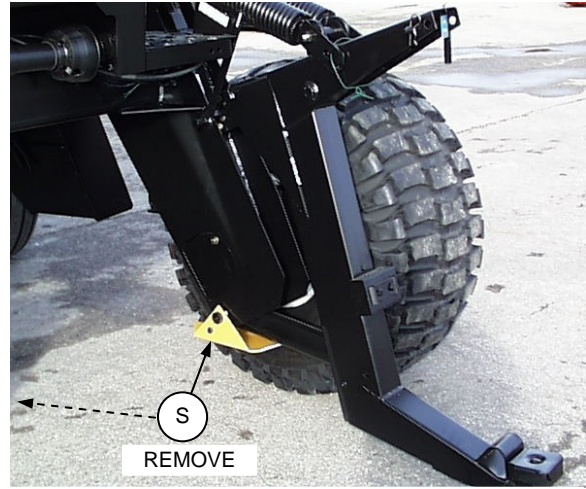

INSTALL DRIVE TIRES & REMOVE SKID SHOES

DRIVE TIRE INFLATION

Check the tire pressures and adjust if necessary.



CAUTION: When inflating tires, use a clip-on chuck and extension hose long enough to allow you to stand to one side and not facing tire.

NOTE: Pressures below are for a fully loaded header. If hay conditioner is removed, or a bat reel replaces a pick-up reel, reduce pressures by 2 psi (14 kPa).

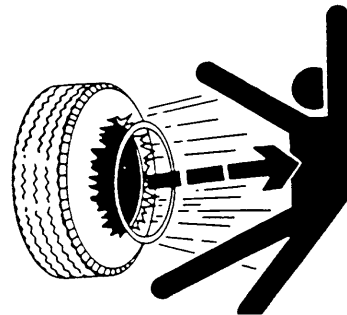

STAND TO ONE SIDE WHEN INFLATING TIRES

Drive Tire Inflation Pressures				
Header Model	Header Size	14.9 - 24	500 - 70R24	540- 65R24 or 560-65D24
912, 922, 933	All	33 psi (228 kPa)	19 psi (132kPa)	18 psi (125 kPa)
962	All	36 psi (248 kPa)	21 psi (145 kPa)	20 psi (138 kPa)
972	12 - 21	33 psi (228 kPa)	19 psi (132kPa)	18 psi (125 kPa)
972/Sprayer	25 - 36	42 psi (289 kPa)	24 psi (165 kPa)	22 psi (151 kPa)

ASSEMBLY

Battery

The windrower is shipped without battery.

BATTERY RECOMMENDATIONS

Battery should meet the following specs:

- 640 amps cold cranking at 0°F (-18°C)
- Reserve Capacity: 180 minutes
- Size: approximately 13 x 6.8 x 9.4 inches (331 x 173 x 238 mm).
- Battery must be vibration proof hybrid type with top posts.

FILL BATTERY (if required)



WARNING: Keep all smoking materials, sparks and flames away from electrolyte container and battery, as gas given off by electrolyte is explosive.

Battery electrolyte causes severe burns. Avoid contact with skin, eyes or clothing. Wear protective eyewear and heavy gloves.

If electrolyte is spilled or splashed on clothing or on the body, neutralize it immediately with a solution of baking soda and water, then rinse with clean water. Electrolyte splashed into the eyes is extremely dangerous. Should this occur, force the eye open and flood with cool, clean water for five minutes. Call a doctor immediately.

If battery is dry, fill battery cells with electrolyte (battery acid).

CHARGE BATTERY



CAUTION: Follow directions regarding charging battery given in Maintenance/Service section and instructions furnished by the battery charger manufacturer.

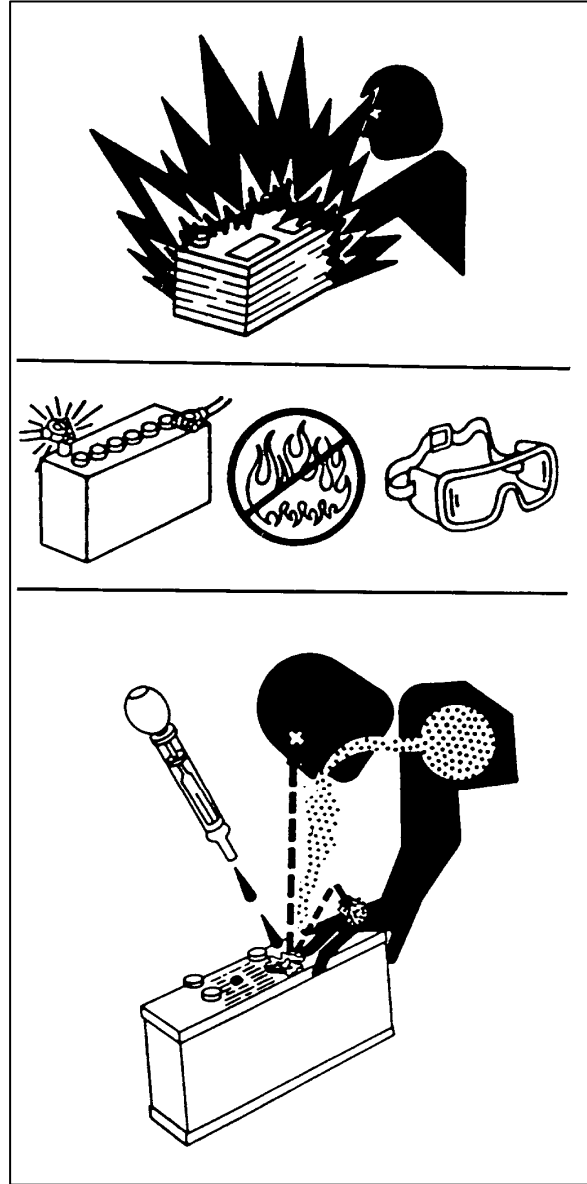

BE CAREFUL AROUND BATTERIES

ASSEMBLY

Battery

INSTALL BATTERY

NOTE: For easier installation, position a low platform on which to stand when placing battery.

1. Lower battery from above onto battery tray located at left rear corner of frame. Position + post towards rear of machine.
2. Install battery holder (A).

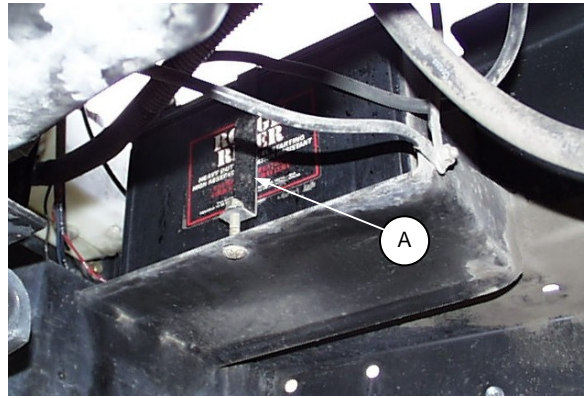

CONNECT BATTERY CABLES

1. Connect starter cable (B) to positive (+) terminal on battery.
2. Connect ground cable (C) to negative (-) terminal on battery.
3. Be sure connections are clean and tight.

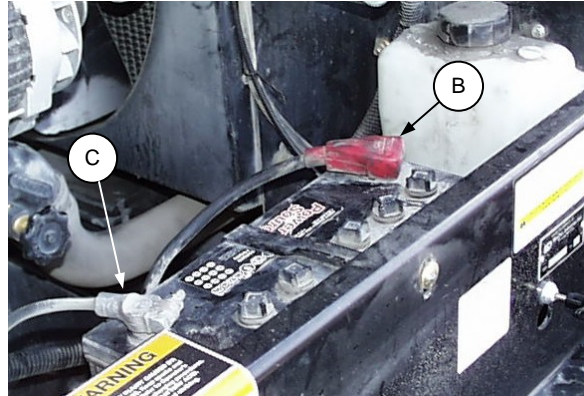

WARNING: Do not run the engine with battery cables disconnected. High voltage can build up in the frame, creating a shock hazard. Alternator damage will also result.

INSTALL BATTERY

When the preceding assembly work is complete, the windrower tractor is in running condition.



WARNING: Avoid driving the tractor with header removed. Removing header decreases the weight on drive wheels, reducing steering control. If necessary to drive tractor with header removed, use transmission low speed range, do not exceed HALF maximum engine speed and avoid loose gravel and slopes. Refer to instructions in this manual on Starting, Driving and Stopping the Windrower.

Adjustments and Checks

Perform the final checks and adjustments as listed on the "Pre-Delivery Checklist" (yellow insert) to ensure the machine is field-ready. Use the Operator's Manual for directions.

NOTE: See following pages for Assembly Instructions related to specific headers and attachments. Once these details are completed, attach header to tractor. See Operation section.

Cab Heater

There is a shut-off valve on the heater circuit at the engine. The tractor is shipped with this valve in the closed position to ensure there is no leakage through the heater circuit when it is not being used. This provides maximum cooling when the air conditioning system is used. If heater is to be used, open valve at (A) by turning handle fully out.

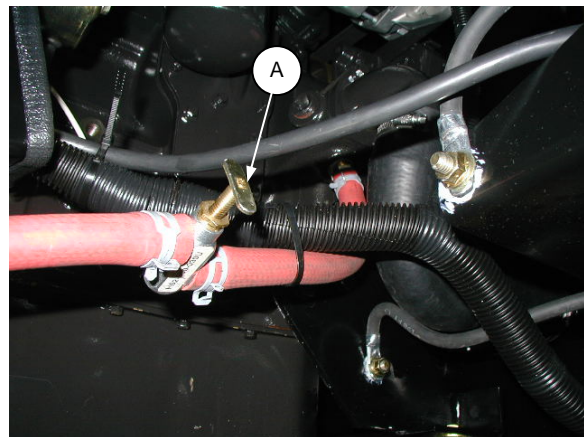

OPEN HEATER VALVE IF REQUIRED

ASSEMBLY

Preparing the Tractor for 962/963 & 972 Headers

1. Remove plastic blocks (A) on tractor lift legs and reinstall as shown with 1/2 x 5 inch bolts provided.

NOTE: For 12' 972 Header only, install extensions (D) with 1/2 x 1 inch hex head bolts and lock nuts.

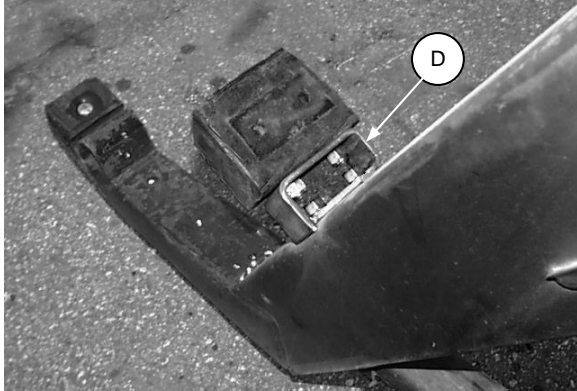

LINKAGE BLOCK EXTENSIONS – 12' 972

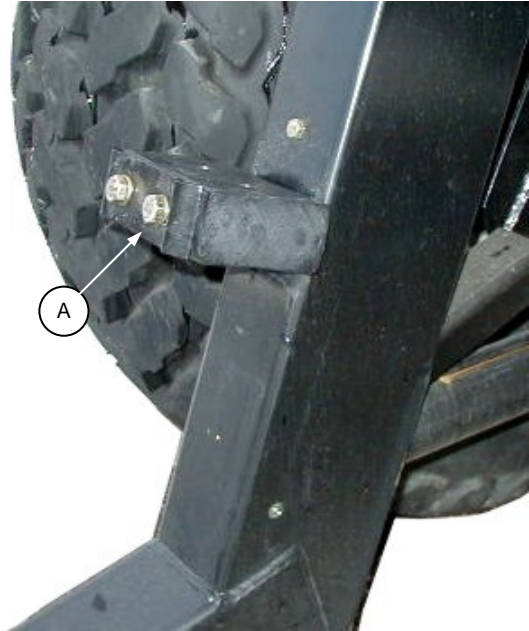

REPOSITION LIFT LINKAGE BLOCKS

2. For 972 Hydraulic Deck Shift Harvest Header, install deck shift switch (B) (shipped with header) in side console as follows:

- Cut decal to expose switch hole punch-out.
 - Remove punch-out and attach wires from harness to switch as shown.
- NOTE:** If header has a serial plate with production year 2000-1 or older, the switch provided with the header will be too small for hole in console panel. Use backing plate if provided, or order switch 109063.

- Replace 10 amp circuit breaker (C) in cab with 12 amp breaker (shipped with header). See page 87 for access to breaker panel.

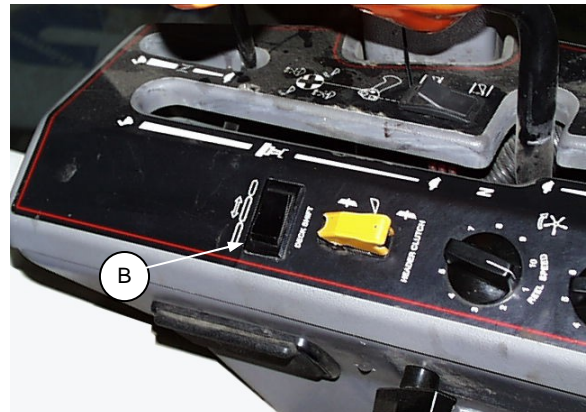

INSTALL DECK SHIFT SWITCH (972 Hydraulic Deck Shift Headers)

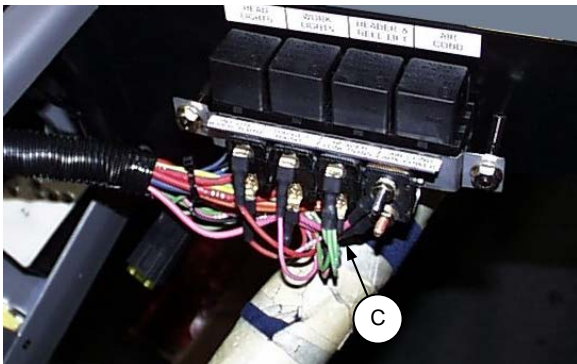

IN-CAB CIRCUIT BREAKERS

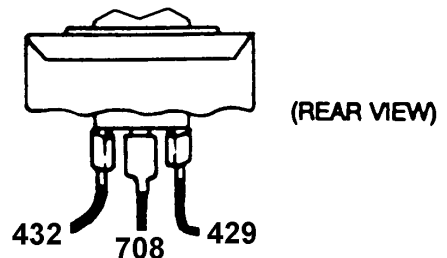

DECK SHIFT SWITCH WIRING

- When header is attached, check function of deck shift switch. Pressing left side of rocker switch should shift decks to the left. If pressing left side of rocker shifts decks to the right and vice-versa, exchange positions of the two outside wires at the switch, or reverse position of switch in console.

ASSEMBLY

Preparing 962/963 Harvest Header for Windrower Tractor

1. Attach lift linkage supports to lower header legs with 5/8 locknut at (A).

NOTE: For 963 Header, remove existing linkage supports first.

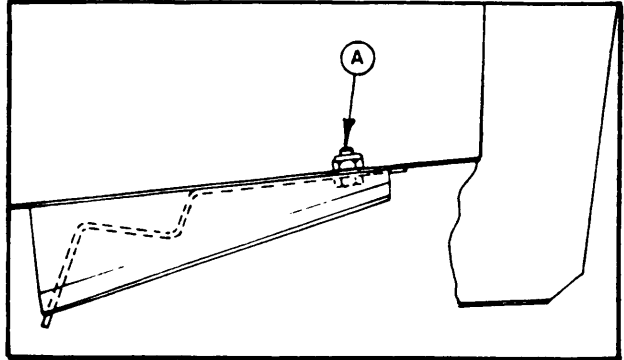

ATTACH LINKAGE SUPPORTS
TO HEADER LEGS – 962/963 HEADER

2. Attach connector shaft assembly to header frame tube as follows:

- With carriage bolt and nut installed loosely in plate (C) of shaft assembly, engage head of carriage bolt in key-hole slot in header frame tube near left leg.
- Holding left side of shaft assembly slightly away from tube, slide shaft assembly to the left, so bolt enters narrow section of key-hole slot and plate (D) aligns with outboard side of lug welded to header frame tube.
- Fasten plate (D) to lug with two 3/8 x 1 inch carriage head bolts and flange locknuts.
- Tighten nut to secure shaft assembly at plate (C).
- Attach header driveline to outboard end of connector shaft. Attach clamp yoke end of driveline to header drive shaft.

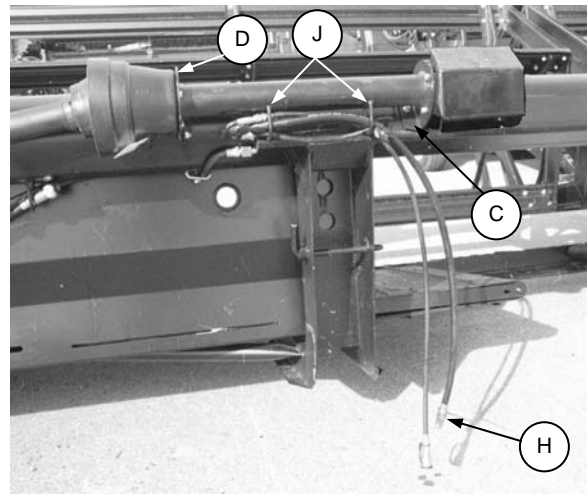

ATTACH CONNECTOR SHAFT
TO HEADER FRAME TUBE &
ADD DRAPER RETURN HOSE EXTENSION
962/963 HEADER

3. Remove blue male coupler from draper return hose. Add hose extension from adapter kit to draper return hose and install coupler on end of hose extension at (H). Route hose through loops (J) on connector shaft as shown.

4. Move reel drive couplers mounting plate from side of header leg to position (E) shown.

IMPORTANT: Damage to couplers may occur if plate is not re-positioned.

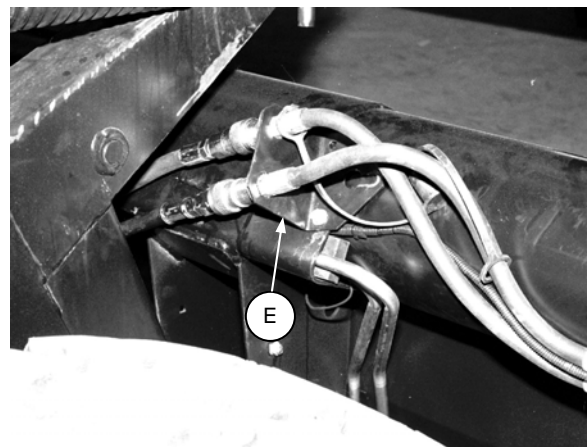

RE-POSITION REEL DRIVE COUPLERS
962/963 HEADERS

ASSEMBLY

Preparing 962/963 Harvest Header for Windrower Tractor (continued)

5. Attach reel lift hose and coupler (supplied in adapter kit) as follows:

30': Attach to hydraulic line (F) at header left leg.

36': Attach to hose (G) at header left leg.

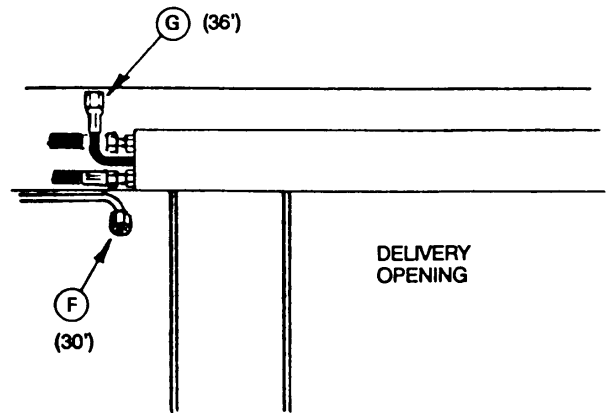

ATTACH REEL LIFT HOSE – 962/963 HEADER

ASSEMBLY

Preparing 972 Harvest Header (21' to 36') for Windrower Tractor

1. Attach lift linkage supports (A) inside lower header legs with 5/8 x 6-1/2 carriage bolt, lockwasher and nut. Use the top hole in the leg as shown.
2. For 21' & 25' Headers, attach center section of wear plate (D) to cutterbar at delivery opening. Longer guard bolts are positioned at the correct locations.
3. Attach skid shoes (B) at header legs with 5/8 x 1-1/2 carriage bolts and flange nuts.
4. Attach reel lift coupler to hose at header left leg.
5. Ensure drive shaft on header is for Windrower Configuration. See 972 Header Operator's Manual.

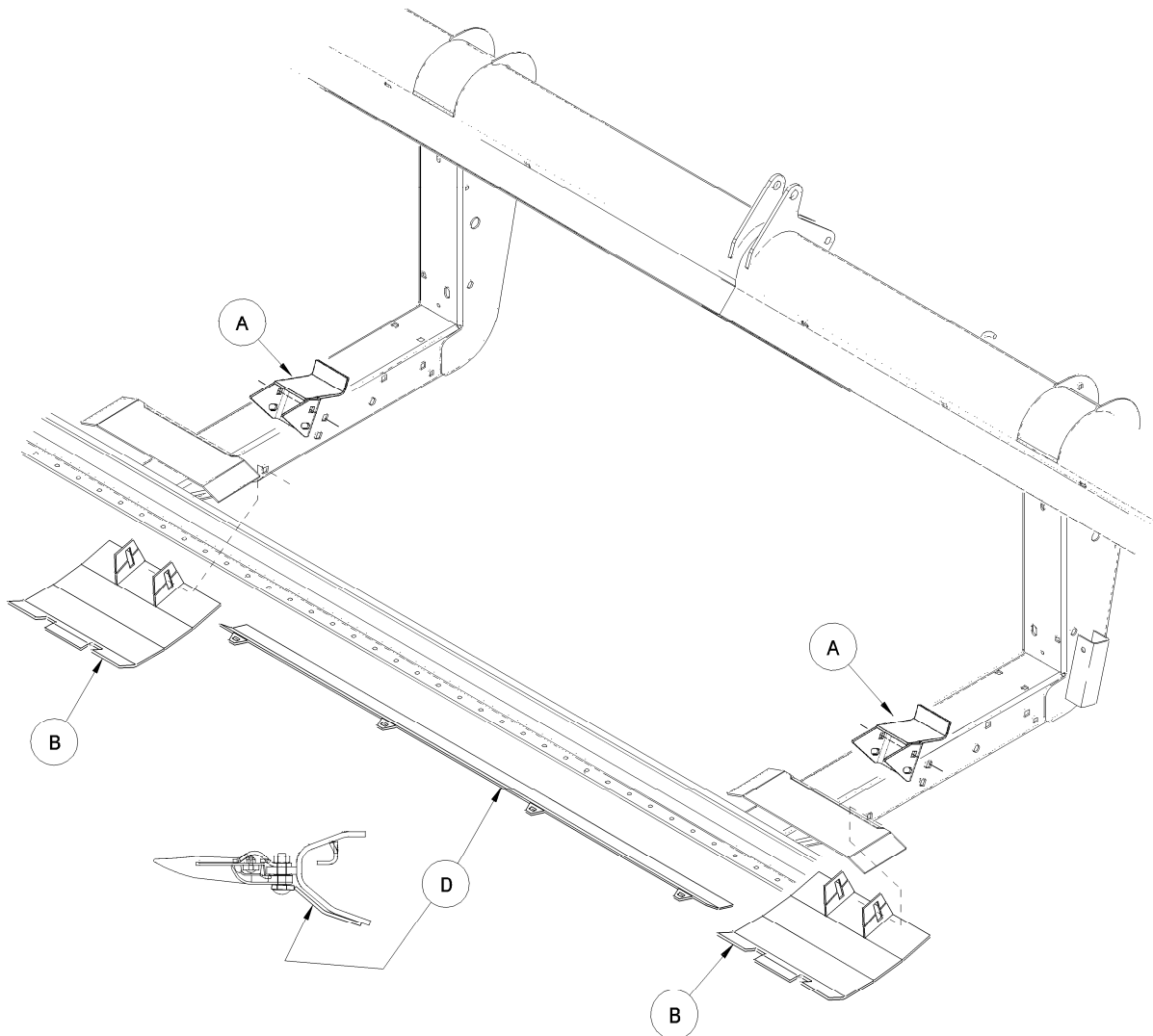

21' to 36' 972 HEADERS – WINDROWER COMPLETION PACKAGE

ASSEMBLY

Radio Installation

Provision has been made for easy installation of a radio:

- Remove six screws around outer edge of panel (A). Panel hangs on wiper motor with a plastic tie. If it is desired to work at a bench, unplug turn signal lights and slip tie off motor to release panel.
- Remove decal (B) and remove radio cut-out piece from panel (A) by cutting through four tabs.
- Install radio in cut-out.
- Secure rear of radio body to support (F).
NOTE: For short body radio, bend support (F) as required.
- A six-pin connector for the radio is included in the wiring harness. In order to mate properly with this connector, the radio must have a six-pin connector (Packard #2977042) and have a terminal arrangement as follows:

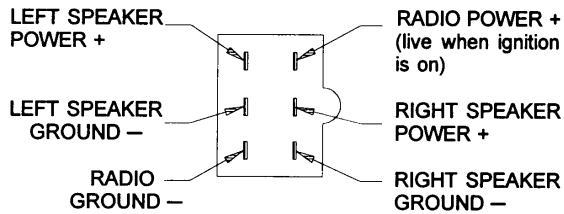

- Attach two additional wires in the wiring harness to the radio:
Circuit 503, Red with 1/4" female blade terminal. This is a live wire provided for powering a radio clock/memory, if these exist on your radio.
Circuit 315, Black ground wire attaches to radio body.
- Plug cable from antenna into radio.

NOTE: An approved radio package is available from Radio Engineering Industries (REI) of Omaha, Nebraska.

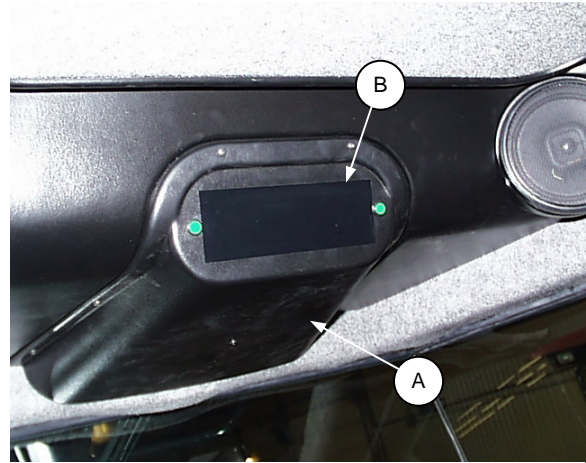

RADIO CUT-OUT LOCATION

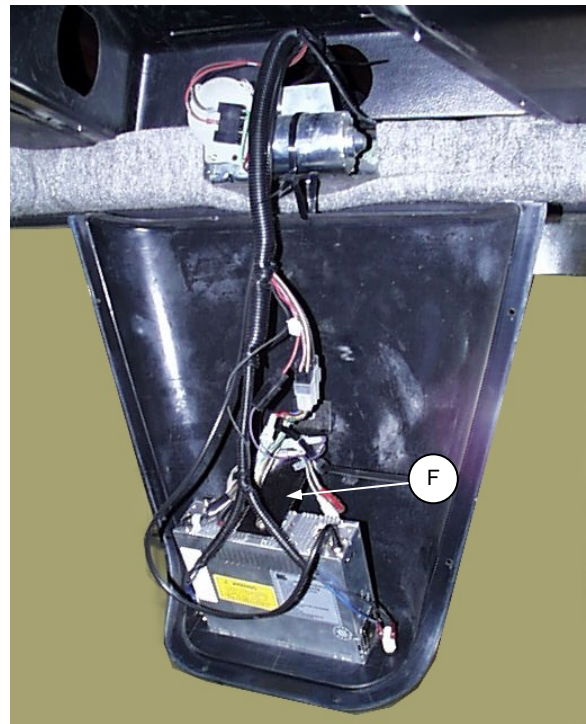

RADIO REAR SUPPORT



RADIO INSTALLED

ASSEMBLY

Two-Way Radio Installation

At the rear of the side console (D), you will find two auxiliary power points provided for accessories such as a two-way radio.

To mount antenna to cab roof:

- Remove console lower panel (to right of operator's seat) and route antenna cable (E) from the radio into the console.
- Remove instrument panel on cab right post. Follow cab wiring harness into headliner.
- Remove wiper motor cover and/or right radio speaker for access to inside of headliner.

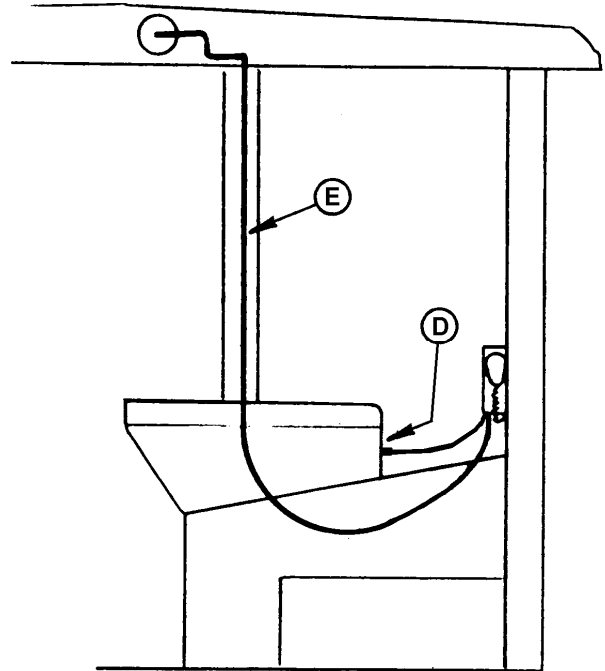

TWO-WAY RADIO ANTENNA ROUTING

Tool Box

Hang the tool box on frame bracket as shown.



ATTACH TOOL BOX

ASSEMBLY

Swath Roller

A hitch for a pull-behind swath roller can be attached at two bottom bolts (A) on walking beam pivot plate.

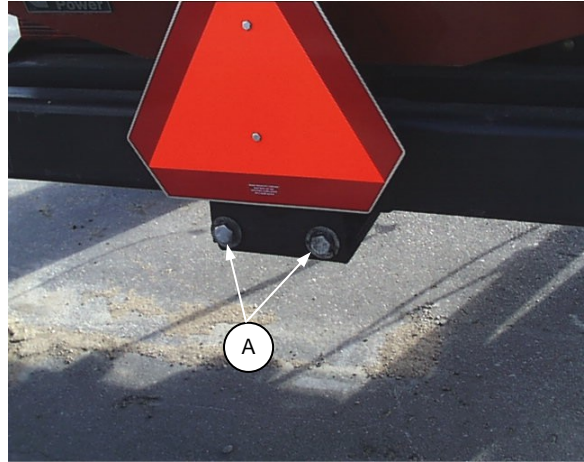

ATTACH SWATH ROLLER HITCH HERE

A direct mounted swath roller can be installed at holes provided in frame at (B).

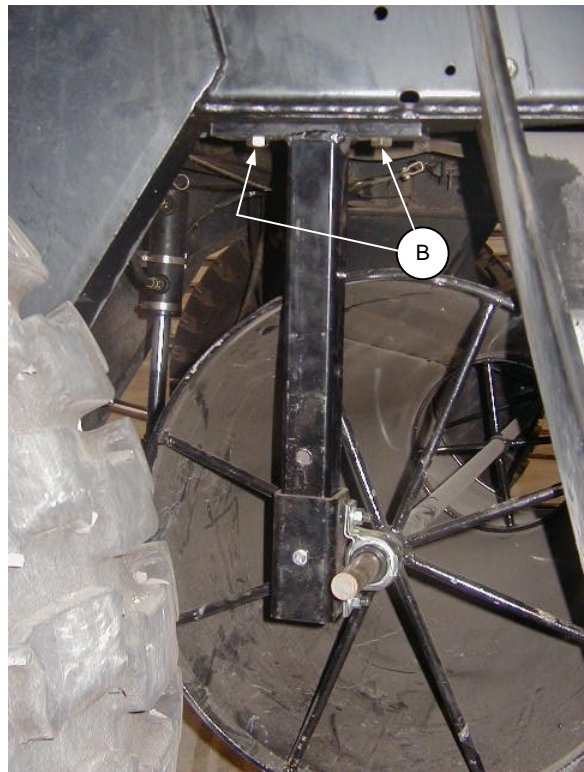

FRAME-MOUNTED SWATH ROLLER

INDEX

<u>A</u>	PAGE	<u>E</u>	PAGE
Air Cleaner – Engine	68	Emergency Exit	39
Air Conditioning System Maintenance	107	Engine Barring Tool	64
Air Intake Screen Cleaner (Attachment).....	129	Engine Compartment Hood	64
Air Removal - Fuel System.....	73	Engine - Diesel.....	64
Alarms - System Malfunction.....	18	Engine Inspection	67
Alternator/Regulator	82	Engine Specifications.....	12
Anti-freeze Concentration.....	76	Engine Speed - Throttle Rod Adjustment	67
Assembly	132	Engine Trouble Shooting	117
Assembly Checks and Adjustments	135	Exhaust System	75
 <u>B</u>		 <u>F</u>	
Battery - Booster	81	Filter - Air Cleaner	68
Battery - Charging	81	Filter - Cab Fresh Air Intake	107
Battery - Maintenance	80	Filter - Cab Return Air	108
Battery - Preventing Damage	80	Filter - Engine Oil	64
Battery - Safety.....	79	Filter - Fuel	72
Battery - Selection & Installation	134	Filter - Hydraulic Oil.....	89
Belt - Header Drive	92	Forked Tail-Wheel Casters (Option)	129
Belt Guides - Header Drive	94	Fuel Recommendations	58
Belts - Diesel Engine	65	Fuel Sediment Bowl	71
Bevel Gear Box Lubricant	92	Fuel Storage.....	70
Bleeding Fuel System	73	Fuel System	70
Break-In Period	28	Fuel Tank Venting.....	70
Bulbs - Replacement.....	84	Fuel/Water Separator.....	71
 <u>C</u>		Fuses - see Circuit Breakers.....	87
Cab Air System	108	 <u>G</u>	
Cab Air System: Compressor Diagnostics	109	Gauges.....	19
Cab Air System: Refrigerant Oil	109	Glow Plug Switch	20
Cab Air System Trouble Shooting	114	Greasing the Windrower Tractor.....	61
Cab Temperature Controls.....	21	Ground Speed Control Lever	22
Capacities - Systems.....	60	Ground Speed Lever Friction Device	103
Charge Pump Pressure.....	96	 <u>H</u>	
Circuit Breakers.....	87	Harvest Header - Special Preparations	136
Condenser - A/C, Cleaning	78	Header Angle	48
Conveyor Speed Control	23	Header Attaching	40
Coolant - Changing	77	Header & Reel Lift Hydraulics	90
Coolant Level	76	Header & Reel Lift Schematic.....	back of book
Coolant Recommendations	59	Header Controls	23
Cooler - Hydraulic Oil	78	Header Detaching	45
Coolers - Cleaning.....	78	Header Drive Belt.....	92
Cooling System	76	Header Drive Belt Pulley Alignment.....	93
Cylinder Control Valve Relief Pressure	90	Header Drive Hydraulic Flow Control.....	91
 <u>D</u>		Header Drive Hydraulic Schematic .	back of book
Draper Speed Control	23	Header Drive Relief Pressure	91
Driving Forward	35	Header Drive Switch	23
Driving - On Roads.....	51	Header Drive Trouble Shooting	126
Driving Rearward.....	36	Header Express Down Module (Attachment)	129
Driving Safety	34	Header Flotation.....	49
Driving - Spin Turn	37	Header Hydraulics Trouble Shooting	126
 <u>E</u>		Header Levelling	49
Electrical Schematics	back of book	Header Lift Cylinder Stops	47
Electrical System.....	79	Header Operation.....	47
Electrical System Trouble Shooting	122	Header Tilt Module.....	129
		Hydraulic System Maintenance.....	88

INDEX

<u>I</u>	PAGE
Ignition Switch	20
 <u>J</u>	
Jacking Procedure.....	106
 <u>L</u>	
Ladder – R/H side	58
Leaving the Windrower.....	39
Lights - Control of	20
Lights, Servicing	83
Lubricant Recommendations.....	59
Lubricant Storage	60
 <u>M</u>	
Maintenance Record	112
Maintenance Schedule.....	110
Monitors - Machine	17
Muffler	75
 <u>N</u>	
Neutral Lock and Steering Checks.....	97
Neutral Lock and Steering Troubleshooting..	100
Neutral Set-Up Procedure	101
 <u>O</u>	
Oil - Diesel Engine.....	60
Oil - Hydraulic.....	59
Operator Amenities	27
Operator Presence System	19
Operator Presence System Maintenance	58
Operator's Station.....	17
Options and Attachments	129
 <u>P</u>	
Power Hubs.....	104
Power Hub Gear Lubricant.....	60
Pre-Starting Checks: Annual	30
Pre-Starting Checks: Daily	31
Pulley Shield Adjustment (Header Drive).....	95
 <u>R</u>	
Radiator Cap	76
Radiator Screen	78
Radio Approved Source	129
Radio Installation	140
Reel Fore-Aft Module	129
Reel Height Control	24
Reel Speed Control	23
Refrigerant Charge.....	109
Refuelling Windrower	70
Responsibilities - Owner/Operator	28
Roller Installation Location	142

<u>S</u>	PAGE
Safety:	
Alert Symbol.....	6
Battery.....	79
Driving the Windrower.....	34
Emergency Exit.....	39
General Farm	9
Header Lift Cylinder Stops	47
High Pressure Fluids	74, 88
Leaving the Windrower	39
Neutral Lock	97
Pre-Starting Checks: Annual.....	30
Pre-Starting Checks: Daily	31
Refrigerant	107
Service Procedures.....	57
Signal Words.....	6
Signs	7
Start-Up Procedure	32
Stopping the Windrower.....	38
Stopping the Engine.....	38
Storage Procedure	56
Transporting	51
Your Responsibilities	28
Screens - Cleaning	78
Seat - Adjustments.....	26
Seat - Trouble Shooting	128
Seat Belt Maintenance	58
Seat Belt Use	25
Serial Number Locations.....	5
Service Procedures.....	57
Shallow Header Angle Kit (Attachment).....	129
Specifications:	
Engine	12
Hardware Torques	13
Hydraulic Fitting Torques	14
Tire Pressures.....	12
Windrower Tractor.....	11
Speed Range Control	22
Speedometer.....	19
Start-Up Procedure	32
Steering and Ground Speed	
Trouble Shooting.....	125
Steering Wheel	22
Stopping Procedure - Engine	38
Stopping Procedure - Windrower	38
Storage Procedure	56
Symbol Definitions - Monitors & Controls	15

<u>T</u>	PAGE
Tachometer	18
Throttle Lever	22
Throttle Rod Adjustment	67
Tire Inflation Pressures	12
Tire Installation.....	132
Tire Service.....	106
Tool Box Installation.....	141
Towing With Trailer	52
Towing Without Trailer	54
Traction Drive Hydraulic Schematic....	back of book
Traction Drive: Neutral Lock	97
Traction Drive Trouble Shooting	123
Transmission Relief Pressure	96
Transporting Windrower.....	51

INDEX

<u>I</u> cont'd.	PAGE
Trouble Shooting	114
Trouble Shooting: A/C Diagnostics	109
Two-Way Radio Installation.....	141
 <u>U</u>	
Unloading Preparations.....	130
Unloading With One Forklift	131
Unloading With Two Forklifts.....	130
 <u>V</u>	
Valve Tappets - Engine	67
 <u>W</u>	
Warning Lights - System Malfunction.....	18
Weight - Adding to Rear of Tractor.....	43
Wheel Bolts	105
Wheels and Tires	104
Window Operation.....	39
Windrower Controls.....	22
Wiper Operation	21

Self-Propelled Windrower Pre-Delivery Checklist

Perform these checks and make adjustments as required prior to delivery to your customer. See the Operator's Manual for adjustment details.



CAUTION: Carefully follow the instructions given. Be alert for safety related messages which bring your attention to hazards and unsafe practices.

Serial Numbers: WINDROWER: _____ ENGINE: _____

- Check for damage or missing parts. Remove plastic or tape from air cleaner intake and muffler exhaust.
- Turn SMV sign reflective side out.
- Remove shipping skid shoes from front legs and shipping support from walking beam (yellow parts).
- Install tires and torque to specifications (P. 133).
- Check tire air pressures and adjust as required (P. 133).
- Check power hub lubricant level (P. 104).
- Check engine coolant level and strength at reserve tank (P. 76).
- Check air cleaner and connections (P. 68).
- Check hydraulic oil level and check for leaks along lines (P. 88).
- Check engine oil level (P. 64).
- Check fuel sediment bowl for water & foreign material (P.71). Drain and clean as necessary. Add fuel.
- Check bevel gear box lubricant level (P. 92).
- Check linkage operation at injector pump (P.67).
- Check tension of A/C compressor belt (P. 66).
- Install a properly sized and fully charged battery and connect cables (P. 134).
- Lubricate the machine completely (P. 61).
- Check neutral start system properly adjusted (P. 97).

START ENGINE AND RUN TO OPERATING TEMPERATURE.

- Program Mac-Monitor and check for operation (P. 17).
- Check instrument console gauges (P. 19) and interior lights (P. 20) for operation
- Check engine oil pressure indicator light at Mac-Monitor (P. 18).
- Check alternator charge rate at instrument console (P. 19).
- Check fuel gauge for operation (P. 19).
- Check maximum (no load) engine speed at Mac-Monitor (P. 18):
2530 rpm – Header Not Engaged
- Check air conditioning functioning properly (P. 21).
- Check exterior lights for operation (P. 20).
- Open heater valve at engine compartment if cab heat required (P. 21).
- Attach header (P. 40) and complete the Header Pre-Delivery Checklist.
- Check that all header controls operate correctly and freely (P. 23).
- Remove plastic from seat after pre-delivery is complete.

Date Checked: _____

Checked by: _____

Roof Wiring Schematic

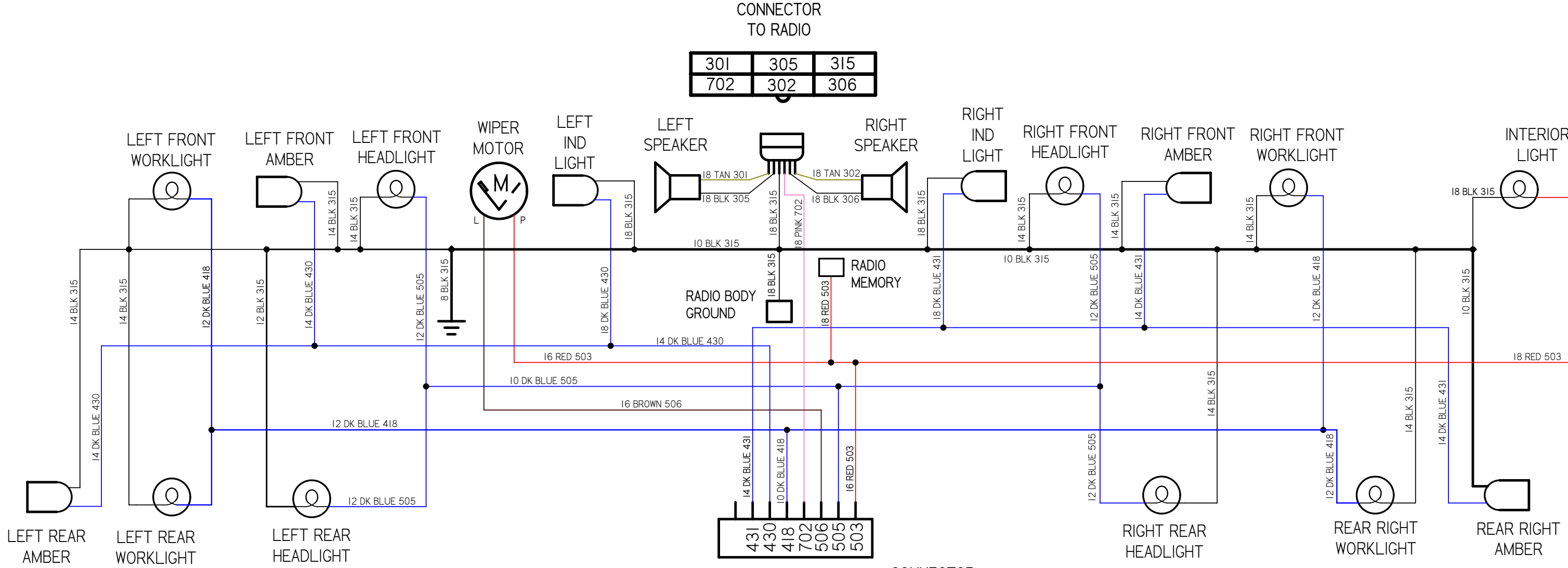

LEGEND

COLOR	FUNCTION
BLACK	GROUND
RED	LIVE POWER SUPPLY
PINK	ACCESSORY POWER SUPPLY
BROWN	WIPER
TAN	SPEAKERS
BLUE	LIGHTS

503	418
505	430
506	431
702	

CONNECTOR TO CAB

NOTE: CIRCUITS ARE IDENTIFIED BY WIRE GAUGE, COLOR & CIRCUIT NUMBER; IE. 16 ORANGE 507 IS A 16 GAUGE WIRE WITH ORANGE INSULATION & THE CIRCUIT NUMBER 507. THIS NOTATION REFERS TO THE LINE IMMEDIATELY BELOW UNLESS INDICATED OTHERWISE

Cab Wiring Schematic

702	431
506	430
505	418
503	418

CONNECTOR TO ROOF

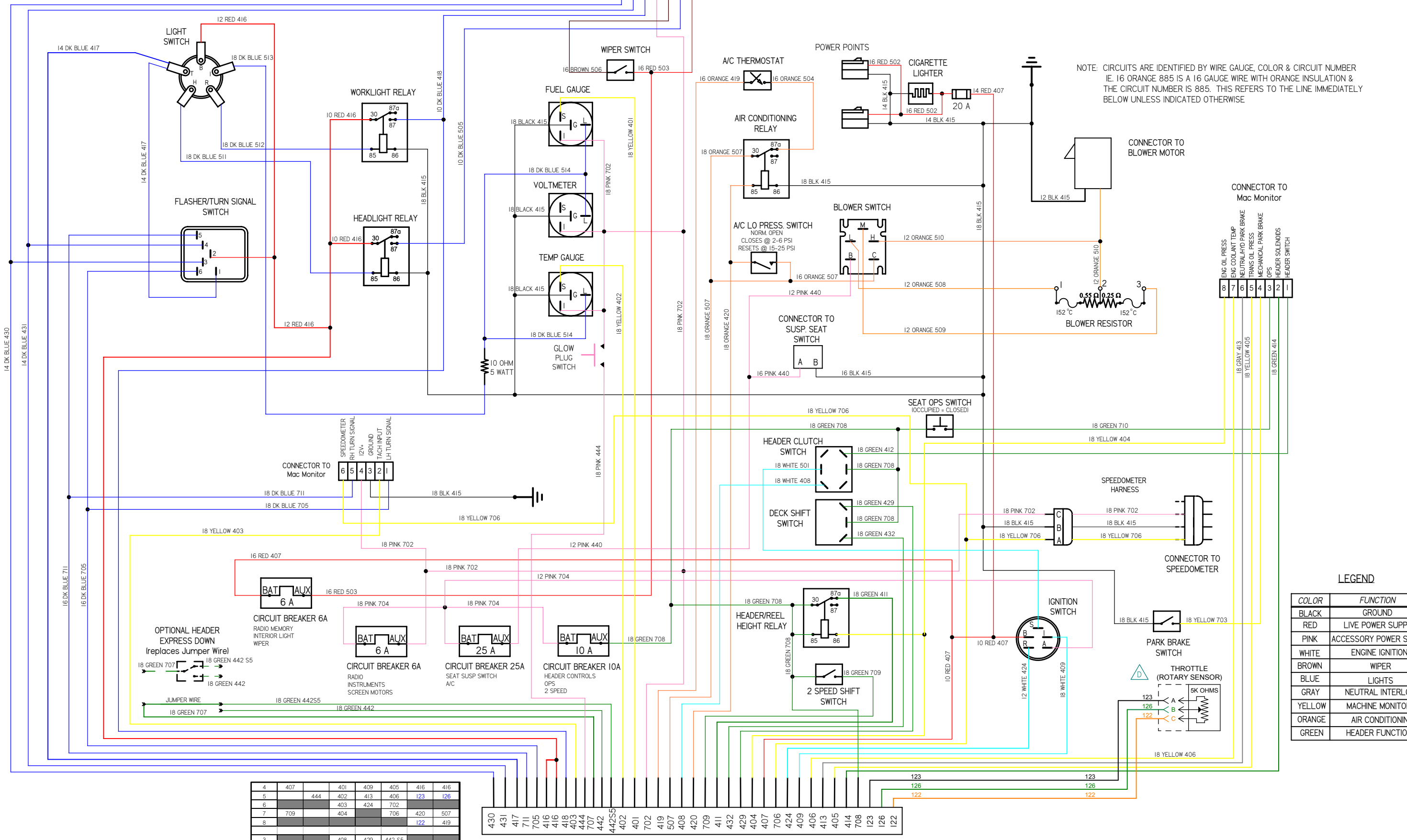

NOTE: CIRCUITS ARE IDENTIFIED BY WIRE GAUGE, COLOR & CIRCUIT NUMBER
 IE. 16 ORANGE 885 IS A 16 GAUGE WIRE WITH ORANGE INSULATION &
 THE CIRCUIT NUMBER IS 885. THIS REFERS TO THE LINE IMMEDIATELY
 BELOW UNLESS INDICATED OTHERWISE

LEGEND

COLOR	FUNCTION
BLACK	GROUND
RED	LIVE POWER SUPPLY
PINK	ACCESSORY POWER SUPPLY
WHITE	ENGINE IGNITION
BROWN	WIPER
BLUE	LIGHTS
GRAY	NEUTRAL INTERLOCK
YELLOW	MACHINE MONITORS
ORANGE	AIR CONDITIONING
GREEN	HEADER FUNCTIONS

4	407	401	409	405	416	416
5		444	402	413	406	123 126
6			403	424	702	
7	709		404		706	420 507
8						122 419
3			408	429	442-55	
2	705	711	411	432	707	430 431
1	418		414	442	708	417
	A	B	C	D	E	F G

CONNECTOR FROM CAB TO TRACTOR

Tractor Wiring Schematic

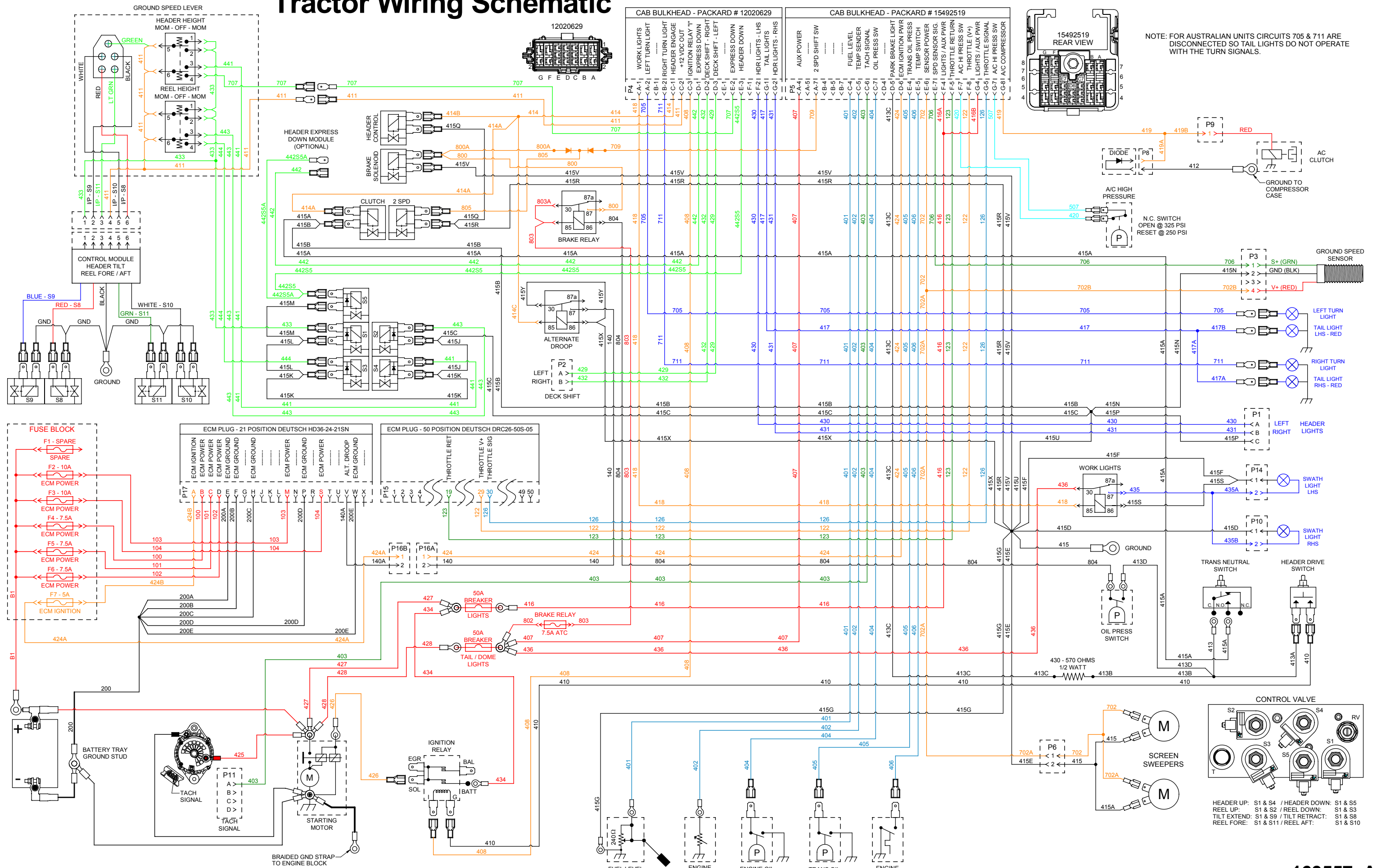

NOTE: FOR AUSTRALIAN UNITS CIRCUITS 705 & 711 ARE DISCONNECTED SO TAIL LIGHTS DO NOT OPERATE WITH THE TURN SIGNALS.

Header & Reel Lift: Hydraulic Schematic (includes brake circuit)

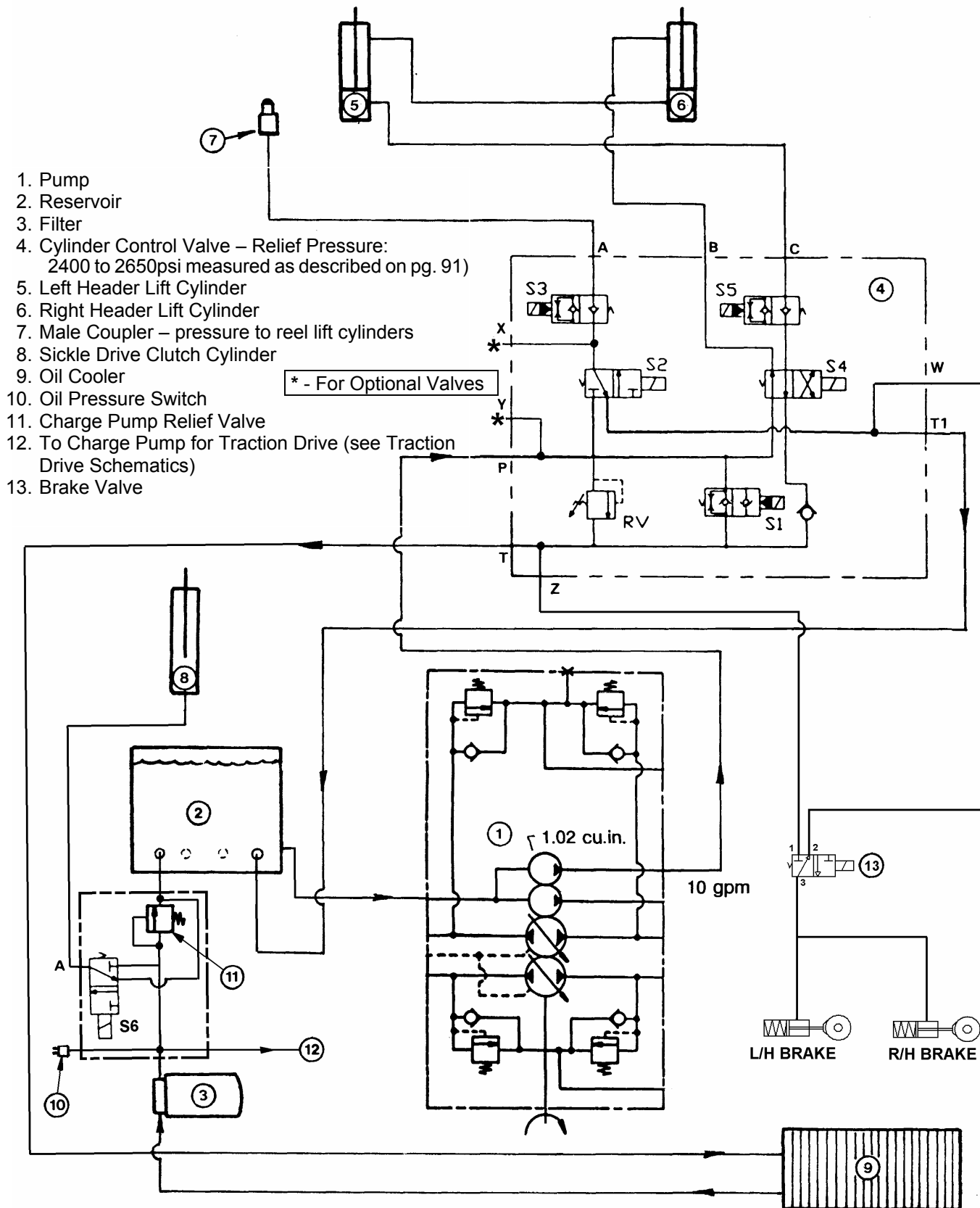

1. Pump
2. Reservoir
3. Filter
4. Cylinder Control Valve – Relief Pressure: 2400 to 2650psi measured as described on pg. 91)
5. Left Header Lift Cylinder
6. Right Header Lift Cylinder
7. Male Coupler – pressure to reel lift cylinders
8. Sickle Drive Clutch Cylinder
9. Oil Cooler
10. Oil Pressure Switch
11. Charge Pump Relief Valve
12. To Charge Pump for Traction Drive (see Traction Drive Schematics)
13. Brake Valve

Hydraulic Options: Reel Fore-Aft & Header Tilt

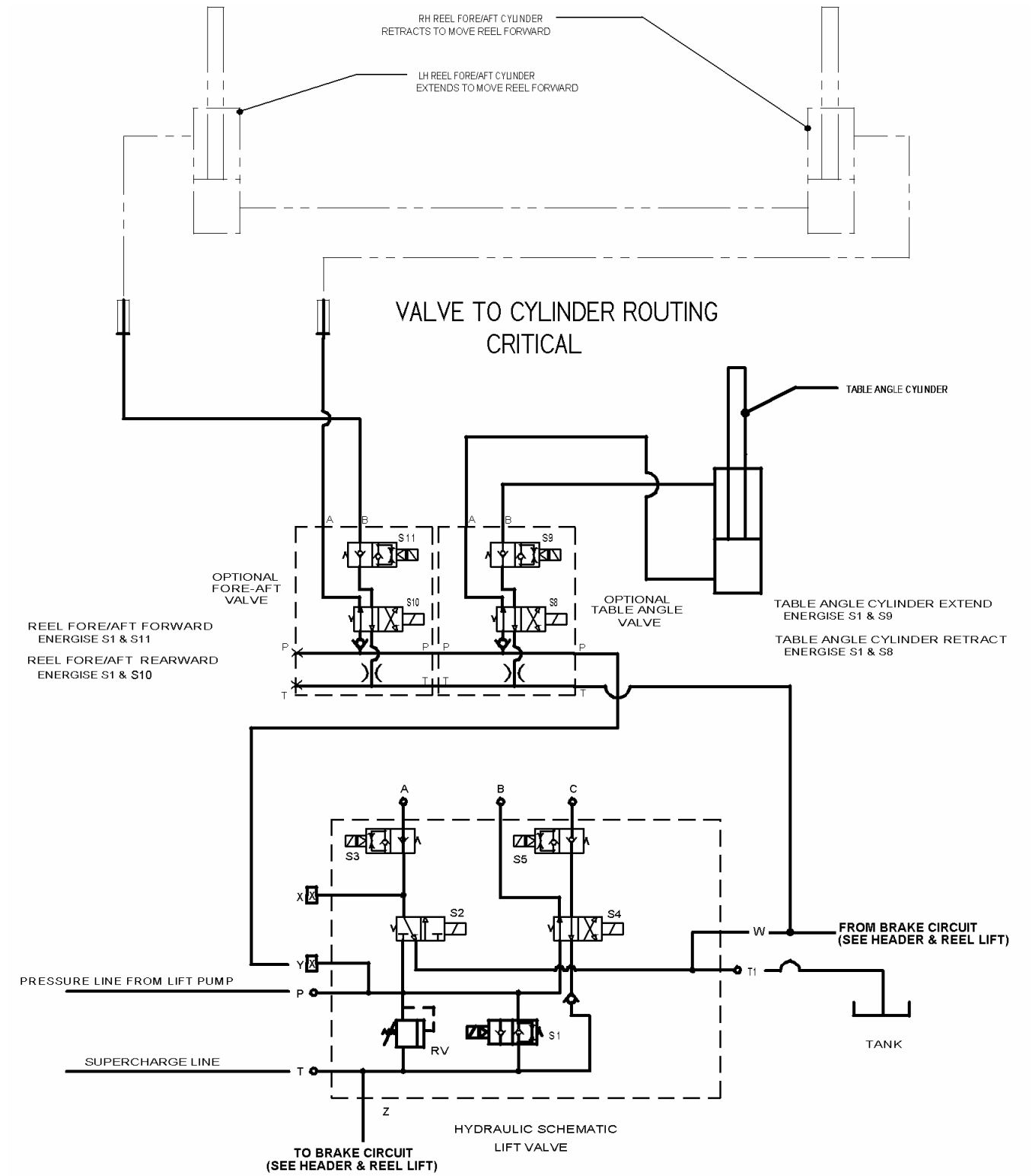

Header Drive: Hydraulic Schematic

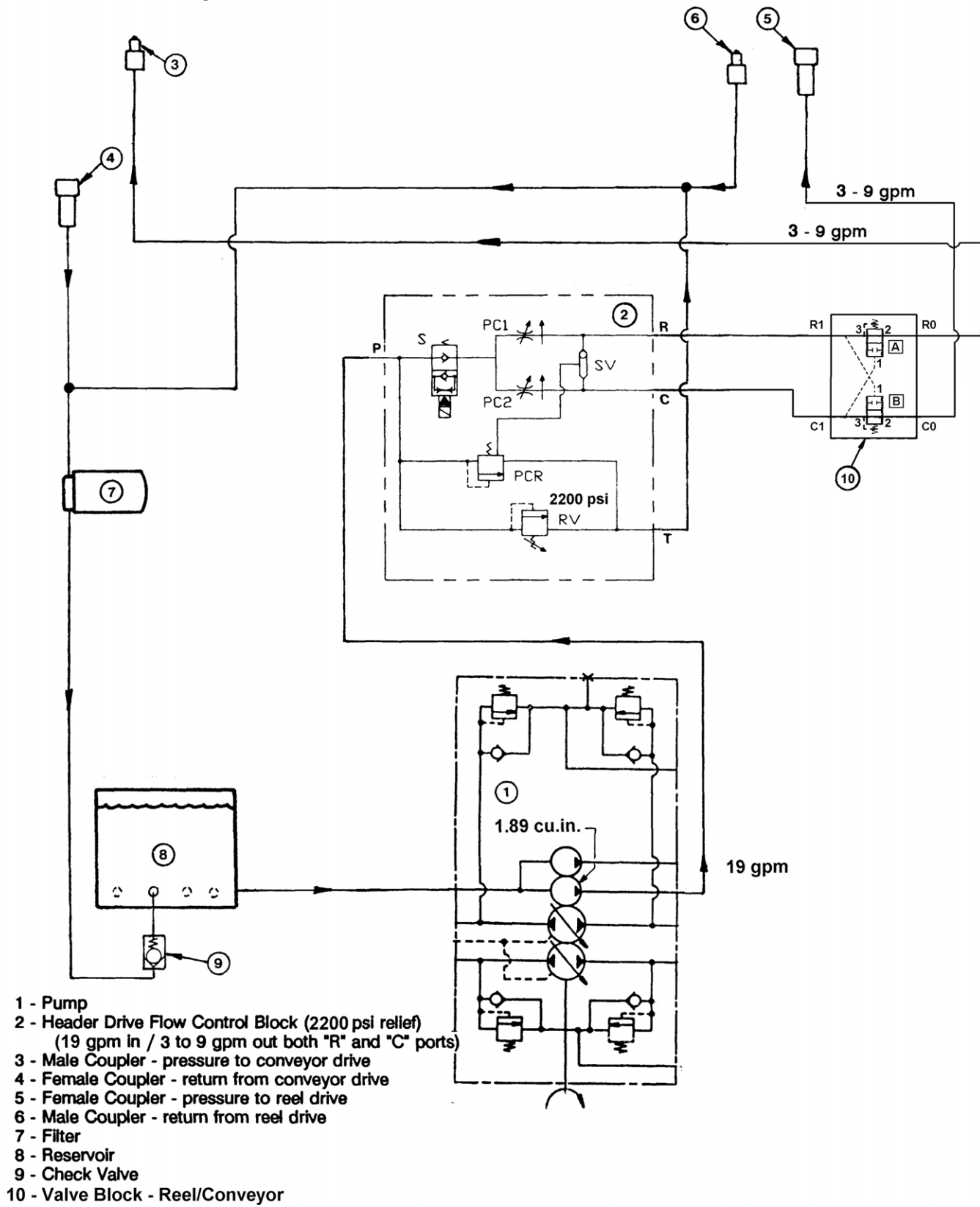

Traction Drive: Hydraulic Schematic

