

**MacDon**<sup>®</sup>

# **M155E4** **Self-Propelled Windrower**

Operator's Manual

147763 Revision A

2016 Model Year

Original Instruction

*The harvesting specialists.*

This manual contains instructions for SAFETY, OPERATION, and MAINTENANCE/SERVICE for the MacDon M155E4 Self-Propelled Windrower. Featuring the Dual Direction® and Ultra Glide® suspension on the M155E4.

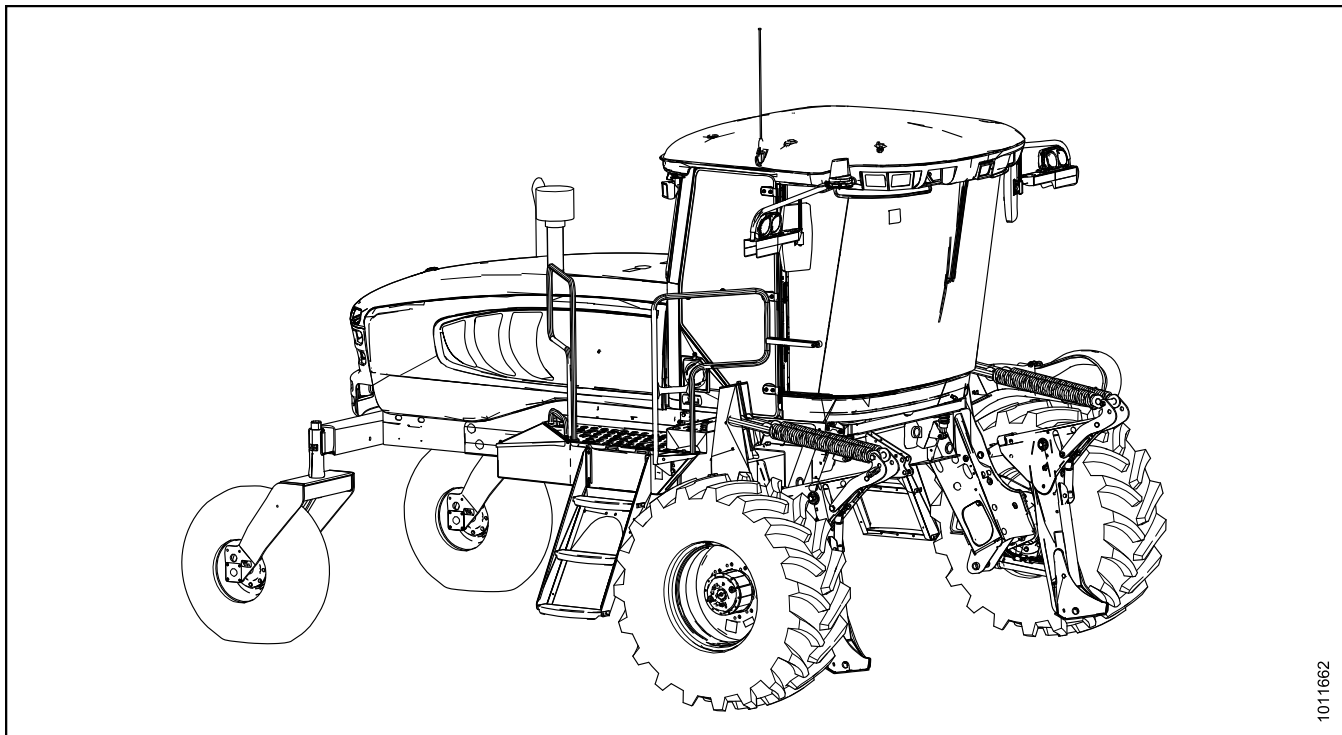

1011662

Published October, 2015

## California Proposition 65 Warning

Diesel engine exhaust and some of its constituents are known to the State of California to cause cancer, birth defects, and other reproductive harm. Battery posts, terminals, and related accessories contain lead and lead components. Wash hands after handling.

# Declaration of Conformity

 <h2 style="margin: 0;">EC Declaration of Conformity</h2>	
<p>[1] <b>MacDon</b>                  MacDon Industries Ltd.                  680 Moray Street,                  Winnipeg, Manitoba, Canada                  R3J 3S3</p>	<p>[4] As Per Shipping Document</p> <p>[5] July 31, 2014</p>
<p>[2] Windrower</p> <p>[3] M155E4</p>	<p>[6] _____                  Natalia Pedersen                  Product Integrity</p>

EN	BG	CZ	DA
<p>We, [1]                      Declare, that the product:                      Machine Type: [2]                      Name &amp; Model: [3]                      Serial Number(s): [4]                      fulfils all the relevant provisions of the Directive 2006/42/EC.                      Harmonized standards used, as referred to in Article 7(2):                      EN ISO 4254-1:2013                      EN ISO 4254-7:2009                      Place and date of declaration: [5]                      Identity and signature of the person empowered to draw up the declaration: [6]                      Name and address of the person authorized to compile the technical file:                      Hartmut Hartmann                      Wersener Holz 2a                      D-49504 Lotte (Germany)                      hartmut.hartmann@prodoku.com</p>	<p>Ние, [1]                      декларираме, че следният продукт:                      Тип машина: [2]                      Наименование и модел: [3]                      Серийен номер(а): [4]                      отговаря на всички приложими разпоредби на директива 2006/42/ЕО.                      Използвани са следните хармонизирани стандарти според чл. 7(2):                      EN ISO 4254-1:2013                      EN ISO 4254-7:2009                      Място и дата на декларацията: [5]                      Име и подпис на лицето, упълномощено да изготви декларацията: [6]                      Име и адрес на лицето, упълномощено да състави техническия файл:                      Хартмут Хартман                      Wersener Holz 2a                      D-49504 Lotte (Германия)                      hartmut.hartmann@prodoku.com</p>	<p>My, [1]                      Prohlašujeme, že produkt:                      Typ zařízení: [2]                      Název a model: [3]                      Sériové(á) číslo(a): [4]                      splňuje všechna relevantní ustanovení směrnice 2006/42/EC.                      Byly použity harmonizované standardy, jak je uvedeno v článku 7(2):                      EN ISO 4254-1:2013                      EN ISO 4254-7:2009                      Místo a datum prohlášení: [5]                      Identita a podpis osoby oprávněné k vydání prohlášení: [6]                      Jméno a adresa osoby oprávněné k vyplnění technického souboru:                      Hartmut Hartmann                      Wersener Holz 2a                      D-49504 Lotte (Německo)                      hartmut.hartmann@prodoku.com</p>	<p>Vi, [1]                      erklærer, at produktet:                      Maskintype [2]                      Navn og model: [3]                      Serienummer (-numre): [4]                      Oplyder alle bestemmelser i direktiv 2006/42/EF.                      Anvendte harmoniserede standarder, som henviser til i paragraf 7(2):                      EN ISO 4254-1:2013                      EN ISO 4254-7:2009                      Sted og dato for erklæringen: [5]                      Identitet på og underskrift fra den person, som er bemyndiget til at udarbejde erklæringen: [6]                      Navn og adresse på den person, som er bemyndiget til at udarbejde den tekniske fil:                      Hartmut Hartmann                      Wersener Holz 2a                      D-49504 Lotte (Tyskland)                      hartmut.hartmann@prodoku.com</p>
<p>Wir, [1]                      Erklären hiermit, dass das Produkt:                      Maschinentyp: [2]                      Name &amp; Modell: [3]                      Seriennummer (n): [4]                      alle relevanten Vorschriften der Richtlinie 2006/42/EG erfüllt.                      Harmonisierte Standards wurden, wie in folgenden Artikeln angegeben, verwendet 7(2):                      EN ISO 4254-1:2013                      EN ISO 4254-7:2009                      Ort und Datum der Erklärung: [5]                      Name und Unterschrift der Person, die dazu befugt ist, die Erklärung auszustellen: [6]                      Name und Anschrift der Person, die dazu berechtigt ist, die technischen Unterlagen zu erstellen:                      Hartmut Hartmann                      Wersener Holz 2a                      D-49504 Lotte (Deutschland)                      hartmut.hartmann@prodoku.com</p>	<p>Nosotros [1]                      declaramos que el producto:                      Tipo de máquina: [2]                      Nombre y modelo: [3]                      Números de serie: [4]                      cumple con todas las disposiciones pertinentes de la directriz 2006/42/EC.                      Se utilizaron normas armonizadas, según lo dispuesto en el artículo 7(2):                      EN ISO 4254-1:2013                      EN ISO 4254-7:2009                      Lugar y fecha de la declaración: [5]                      Identidad y firma de la persona facultada para draw redactar la declaración: [6]                      Nombre y dirección de la persona autorizada para elaborar el expediente técnico:                      Hartmut Hartmann                      Wersener Holz 2a                      D-49504 Lotte (Germany)                      hartmut.hartmann@prodoku.com</p>	<p>Meie, [1]                      deklareerime, et toode                      Seadme tüüp: [2]                      Nimi ja mudel: [3]                      Seerianumberid: [4]                      vastab kõigile direktiivi 2006/42/EÜ asjakohastele sätetele.                      Kasutatud on järgnevald harmoniseeritud standardeid, millele on viidatud ka punktis 7(2):                      EN ISO 4254-1:2013                      EN ISO 4254-7:2009                      Deklaratsiooni koht ja kuupäev: [5]                      Deklaratsiooni koostamiseks volitatud isiku nimi ja allkiri: [6]                      Tehnilise dokumendi koostamiseks volitatud isiku nimi ja aadress:                      Hartmut Hartmann                      Wersener Holz 2a                      D-49504 Lotte (Saksamaa)                      hartmut.hartmann@prodoku.com</p>	<p>Nous soussignés, [1]                      Déclarons que le produit :                      Type de machine : [2]                      Nom et modèle : [3]                      Numéro(s) de série : [4]                      Est conforme à toutes les dispositions pertinentes de la directive 2006/42/EC.                      Utilisation des normes harmonisées, comme indiqué dans l'Article 7(2):                      EN ISO 4254-1:2013                      EN ISO 4254-7:2009                      Lieu et date de la déclaration : [5]                      Identité et signature de la personne ayant reçu le pouvoir de rédiger cette déclaration : [6]                      Nom et adresse de la personne autorisée à constituer le dossier technique :                      Hartmut Hartmann                      Wersener Holz 2a                      D-49504 Lotte (Allemagne)                      hartmut.hartmann@prodoku.com</p>

The Harvesting Specialists

MacDon

101457

Figure 1: Declaration of Conformity (Page 1 of 2)

## EC Declaration of Conformity

IT	HU	LT	LV
<p>Noi, [1] Dichiariamo che il prodotto: Tipo di macchina: [2] Nome e modello: [3] Numero(i) di serie: [4] soddisfa tutte le disposizioni rilevanti della direttiva 2006/42/CE.  Utilizzo degli standard armonizzati, come indicato nell'Articolo 7(2):  EN ISO 4254-1:2013 EN ISO 4254-7:2009  Luogo e data della dichiarazione: [5] Nome e firma della persona autorizzata a redigere la dichiarazione: [6] Nome e persona autorizzata a compilare il file tecnico: Hartmut Hartmann Wersener Holz Za D-49504 Lotte (Germania) hartmut.hartmann@prodoku.com</p>	<p>Mi, [1] Ezennel kijelentjük, hogy a következő termék: Gép típusa: [2] Név és modell: [3] Számszám(ok): [4] teljesíti a következő nyelven összes vonatkozó előírásait: 2006/42/EK.  Az alábbi harmonizált szabványok kerültek alkalmazásra a 7(2) cikkely szerint:  EN ISO 4254-1:2013 EN ISO 4254-7:2009  A nyilatkozattétel ideje és helye: [5] Azon személy kiléte és aláírása, aki jogosult a nyilatkozat elkészítésére: [6] Azon személy neve és aláírása, aly felhatalmazott a műszaki dokumentáció összeállítására: Hartmut Hartmann Wersener Holz Za D-49504 Lotte (Németország) hartmut.hartmann@prodoku.com</p>	<p>Mes, [1] Pateikiame, kad šis produktas: Mašinos tipas: [2] Pavadinimas ir modelis: [3] Serijos numeris (-iai): [4] atitinka taikomus reikalavimus pagal Direktivą 2006/42/EB.  Naudojami harmonizuoti standartai, kai nurodoma straipsnyje 7(2):  EN ISO 4254-1:2013 EN ISO 4254-7:2009  Deklaracijos vieta ir data: [5] Asmenis tapatybes duomenys ir parašas asmens, įgalioto sudaryti šią deklaraciją: [6] Vardas ir pavardė asmens, kuris įgaliotas sudaryti šį techninį failą: Hartmut Hartmann Wersener Holz Za D-49504 Lotte (Vokietija) hartmut.hartmann@prodoku.com</p>	<p>Mēs, [1] Deklarējam, ka produkts: Mašīnas tips: [2] Nosaukums un modelis: [3] Sērijas numurs(-i): [4] Atbilst visām būtiskajām Direktīvas 2006/42/EK prasībām.  Piemēroti štādi saskaņotie standarti, kā minēts 7. panta 2. punktā:  EN ISO 4254-1:2013 EN ISO 4254-7:2009  Deklarācijas parakstīšanas vieta un datums: [5] Tās personas vārds, uzvārds un paraksts, kas ir pilnvarota sagatavot šo deklarāciju: [6] Tās personas vārds, uzvārds un adrese, kas ir pilnvarota sastādīt tehnisko dokumentāciju: Hartmut Hartmann Wersener Holz Za D-49504 Lotte (Vācija) hartmut.hartmann@prodoku.com</p>
<p>Wij, [1] Verklaren dat het product: Machinetype: [2] Naam en model: [3] Serienummer(s): [4] voldoet aan alle relevante bepalingen van de Richtlijn 2006/42/EC.  Geharmoniseerde normen toegepast, zoals vermeld in Artikel 7(2):  EN ISO 4254-1:2013 EN ISO 4254-7:2009  Plaats en datum van verklaring: [5] Naam en handtekening van de bevoegde persoon om de verklaring op te stellen: [6] Naam en adres van de geautoriseerde persoon om het technisch dossier samen te stellen: Hartmut Hartmann Wersener Holz Za D-49504 Lotte (Duitsland) hartmut.hartmann@prodoku.com</p>	<p>My nizej podpisani, [1] Oświadczamy, że produkt: Typ urządzenia: [2] Nazwa i model: [3] Numer seryjny/numery seryjne: [4] spełnia wszystkie odpowiednie przepisy dyrektywy 2006/42/WE.  Zastosowaliśmy następujące (zharmonizowane) normy zgodnie z artykułem 7(2):  EN ISO 4254-1:2013 EN ISO 4254-7:2009  Data i miejsce oświadczenia: [5] Imię i nazwisko oraz podpis osoby upoważnionej do przygotowania deklaracji: [6] Imię i nazwisko oraz adres osoby upoważnionej do przygotowania dokumentacji technicznej: Hartmut Hartmann Wersener Holz Za D-49504 Lotte (Niemcy) hartmut.hartmann@prodoku.com</p>	<p>Nós, [1] Declaramos, que o produto: Tipo de máquina: [2] Nome e Modelo: [3] Número(s) de Série: [4] cumpre todas as disposições relevantes da Directiva 2006/42/CE.  Normas harmonizadas aplicadas, conforme referido no Artigo 7(2):  EN ISO 4254-1:2013 EN ISO 4254-7:2009  Local e data da declaração: [5] Identidade e assinatura da pessoa autorizada a elaborar a declaração: [6] Nome e endereço da pessoa autorizada a compilar o ficheiro técnico: Hartmut Hartmann Wersener Holz Za D-49504 Lotte (Alemanha) hartmut.hartmann@prodoku.com</p>	<p>Noi, [1] Declarăm, că următorul produs: Tipul mașinii: [2] Denumirea și modelul: [3] Număr (numere) serie: [4] corespunde tuturor dispozițiilor esențiale ale directivei 2006/42/EC.  Au fost aplicate următoarele standarde armonizate conform articolului 7(2):  EN ISO 4254-1:2013 EN ISO 4254-7:2009  Data și locul declarației: [5] Identitatea și semnătura persoanei împuternicite pentru întocmirea declarației: [6] Numele și semnătura persoanei autorizate pentru întocmirea cărții tehnice: Hartmut Hartmann Wersener Holz Za D-49504 Lotte (Germania) hartmut.hartmann@prodoku.com</p>
<p>Mi, [1] Izjavljujem da proizvod Tip mašine: [2] Naziv i model: [3] Serijski broj(ovi): [4] ispunjava sve relevantne odredbe direktive 2006/42/EC.  Korišćeni su usklađeni standardi kao što je navedeno u članu 7(2):  EN ISO 4254-1:2013 EN ISO 4254-7:2009  Datum i mesto izdavanja deklaracije: [5] Identitet i potpis lica ovlašćenog za sastavljanje deklaracije: [6] Ime i adresa osobe ovlašćene za sastavljanje tehničke datoteke: Hartmut Hartmann Wersener Holz Za D-49504 Lotte (Nemačka) hartmut.hartmann@prodoku.com</p>	<p>Mi, [1] Intygat att produkten: Maskintyp: [2] Namn och modell: [3] Serienummer: [4] uppfyller alla relevanta villkor i direktivet 2006/42/EG.  Harmoniserade standarder används, såsom anges i artikel 7(2):  EN ISO 4254-1:2013 EN ISO 4254-7:2009  Plats och datum för intyget: [5] Identitet och signatur för person med befogenhet att upprätta intyget: [6] Namn och adress för person behörig att upprätta den tekniska dokumentationen: Hartmut Hartmann Wersener Holz Za D-49504 Lotte (Tyskland) hartmut.hartmann@prodoku.com</p>	<p>Mi, [1] Izjavljamo, da izdelek: Vrsta stroja: [2] Ime in model: [3] Serijska/-e številka/-e: [4] ustreza vsem zadevnim določbam Direktive 2006/42/ES.  Uporabljeni usklajeni standardi, kot je navedeno v členu 7(2):  EN ISO 4254-1:2013 EN ISO 4254-7:2009  Kraj in datum izjave: [5] Istovetnost in podpis osebe, pooblaščenega za pripravo izjave: [6] Ime in naslov osebe, pooblaščenega za pripravo tehnične datoteke: Hartmut Hartmann Wersener Holz Za D-49504 Lotte (Nemčija) hartmut.hartmann@prodoku.com</p>	<p>My, [1] Týmto prehlásujeme, že tento výrobok: Typ zariadenia: [2] Názov a model: [3] Výrobné číslo: [4] spĺňa príslušné ustanovenia a základné požiadavky smernice E 2006/42/ES.  Použitá harmonizované normy, ktoré sa uvádzajú v článku 7(2):  EN ISO 4254-1:2013 EN ISO 4254-7:2009  Miesto a dátum prehlásenia: [5] Meno a podpis osoby oprávnenej vypracovať toto prehlásenie: [6] Meno a adresa osoby oprávnenej zostaviť technický súbor: Hartmut Hartmann Wersener Holz Za D-49504 Lotte (Nemecko) hartmut.hartmann@prodoku.com</p>

1014558

Figure 2: Declaration of Conformity (Page 2 of 2)

## **Whole Body and Hand-Arm Vibration Levels**

The weighted root mean square acceleration, to which the whole body is subjected, ranges from 0.59 to 1.07 m/s<sup>2</sup> as measured on a representative machine during typical operations and analyzed in accordance with ISO 5008.

During the same operations, the weighted root means square hand-arm vibration was less than 1.81 m/s<sup>2</sup> when analyzed in accordance with ISO 5349. These acceleration values depend on the roughness of the ground, the speeds at which the windrower is operated, the operator's experience, weight, and driving habits.

## **Noise Levels**

The A-weighted sound pressure levels inside the operator's station ranged from 66 to 67 dB(A) as measured on several representative machines in accordance with ISO 5131. The sound pressure level depends upon the engine speed and load, field and crop conditions, and the type of platform used.

# Introduction

This manual contains information on the MacDon M155E4 Self-Propelled Windrower which, when coupled with one of MacDon's auger, rotary, or draper headers, provides a package designed to cut and lay in windrows a variety of grain, hay, and specialty crops.

The M155E4 Windrower is Dual Direction®, meaning that the windrower can be driven in the cab-forward or the engine-forward modes. Right and left designations are therefore determined by the operator's position, facing the direction of travel. This manual uses the terms "right cab-forward", "left cab-forward", "right engine-forward", and "left engine-forward" when referencing specific locations on the machine.

Use this manual as your first source of information about the machine. Use the Table of Contents and the Index to guide you to specific areas. Study the Table of Contents to familiarize yourself with how the material is organized.

If you follow the instructions given here, your M155E4 Windrower will work well for many years.

Use this manual in conjunction with your header operator's manual.

A manual storage case is provided in the cab. Keep this manual handy for frequent reference and to pass on to new Operators or Owners. Call your Dealer if you need assistance, information, or additional copies of this manual.

**CAREFULLY READ ALL THE MATERIAL PROVIDED BEFORE ATTEMPTING TO USE THE MACHINE.**

**NOTE:** Keep your MacDon publications up-to-date. The most current version can be downloaded from our website [www.macdon.com](http://www.macdon.com) or from our Dealer-only site (<https://portal.macdon.com>) (login required).

# List of Revisions

The following list provides an account of major changes from the previous version of this document.

Summary of Change	Location
Changed book part number	From 169978 to 147763
Updated fuse box decal	<a href="#">Fuse Box Decal, page 383</a>
Replaced the term “diesel exhaust fluid (DEF) pump and DEF dosing unit” with “DEF supply module”	<ul style="list-style-type: none"> <li>• <a href="#">Supply Module Filter, page 334</a></li> <li>• <a href="#">Checking the Supply Module Filter, page 334</a></li> <li>• <a href="#">Removing the Supply Module Filter, page 334</a></li> <li>• <a href="#">Cleaning and Inspecting the Supply Module Filter, page 335</a></li> <li>• <a href="#">8.1.4 Filter Part Numbers, page 445</a></li> </ul>
Replaced the term “DEF dosing valve” with “DEF dosing module”	<ul style="list-style-type: none"> <li>• <a href="#">Removing the Supply Module Filter, page 334</a></li> </ul>
Replaced the term “fuel and DEF gauges” with “fuel and DEF display module”	<ul style="list-style-type: none"> <li>• <a href="#">3.16 Engine Controls and Display Module, page 65</a></li> <li>• <a href="#">Filling the Diesel Exhaust Fluid (DEF) Tank, page 168</a></li> <li>• <a href="#">3.16.1 Fuel and Diesel Exhaust Fluid (DEF) Display Module, page 66</a></li> <li>• <a href="#">Tools Menu, page 68</a></li> <li>• <a href="#">Audible Alarm, page 70</a></li> </ul>
Replaced the term “diesel exhaust fluid (def) fuel strainer filter” to “diesel exhaust fluid (def) vent hose filter”	<a href="#">Replacing the Diesel Exhaust Fluid (DEF) Vent Hose Filter , page 331</a>
Replaced the term “manifold oil filter” and “return filter” with “return oil filter”	<ul style="list-style-type: none"> <li>• <a href="#">5.10.4 Changing Hydraulic Oil Filters, page 391</a></li> <li>• <a href="#">Return Oil Filter, page 393</a></li> <li>• <a href="#">Removing Return Oil Filter, page 393</a></li> <li>• <a href="#">Installing Return Oil Filter, page 393</a></li> <li>• <a href="#">8.1.4 Filter Part Numbers, page 445</a></li> </ul>
Replaced the term “charge filter” with “charge oil filter”	<ul style="list-style-type: none"> <li>• <a href="#">5.10.4 Changing Hydraulic Oil Filters, page 391</a></li> <li>• <a href="#">Charge Oil Filter, page 392</a></li> <li>• <a href="#">Removing Charge Oil Filter, page 392</a></li> <li>• <a href="#">Installing Charge Oil Filter, page 392</a></li> </ul>
Added topic	<ul style="list-style-type: none"> <li>• <a href="#">3.19.5 Programming Guidelines, page 92</a></li> <li>• <a href="#">3.7.4 Hazard Light, page 52</a></li> <li>• <a href="#">3.7.6 Auto Road Light, page 53</a></li> </ul>

Summary of Change	Location
Revised procedure or topic	<ul style="list-style-type: none"> <li>• <a href="#">4.4.3 Levelling the Header, page 200</a></li> <li>• <a href="#">3.10.3 Climate Controls, page 57</a></li> <li>• <a href="#">Display Warnings and Alarms, page 90</a></li> <li>• <a href="#">3.7 Lighting, page 49</a></li> <li>• <a href="#">3.7.1 Field Light: Cab-Forward, page 49</a></li> <li>• <a href="#">3.7.2 Road Light: Engine-Forward, page 50</a></li> <li>• <a href="#">3.7.3 Road Light: Cab-Forward, page 51</a></li> <li>• <a href="#">3.7.5 Beacon Light, page 53</a></li> </ul>
Removed topics	<ul style="list-style-type: none"> <li>• Park Brake</li> <li>• Adjusting and Replacing Interlock Switch</li> </ul>
Added information	<ul style="list-style-type: none"> <li>• <a href="#">Audible Alarm, page 70</a></li> <li>• <a href="#">2.2 Specifications, page 30</a></li> <li>• <a href="#">Adding Coolant, page 341</a></li> <li>• <a href="#">3.17 Windrower Controls, page 71</a></li> </ul>
Changed in routing of engine harness	<ul style="list-style-type: none"> <li>• <a href="#">Replacing the Diesel Exhaust Fluid (DEF) Vent Hose Filter , page 331</a></li> <li>• <a href="#">Checking the Supply Module Filter, page 334</a></li> </ul>
<ul style="list-style-type: none"> <li>• Merged topics Break-In Inspections and Maintenance Schedule/Record into one topic with updated format</li> <li>• Added engine crankcase filter and DEF supply module filter to the maintenance schedule/record</li> </ul>	<ul style="list-style-type: none"> <li>• <a href="#">5.12.1 Maintenance Schedule/Record, page 414</a></li> </ul>
Updated the Definitions section	<ul style="list-style-type: none"> <li>• <a href="#">2.1 Definitions, page 27</a></li> </ul>
<p>Added “unit hours” in the following operating screens:</p> <ul style="list-style-type: none"> <li>• Engine Forward, Engine Running</li> <li>• Cab Forward, Engine Running, Header Disengaged</li> <li>• Cab Forward, Engine Running, Header Engaged, Auger Header Index Switch OFF</li> <li>• Cab Forward, Engine Running, Header Engaged, Auger Header Index Switch ON</li> <li>• Cab Forward, Engine Running, Header Engaged, Draper Header Index Switch OFF</li> <li>• Cab Forward, Engine Running, Header Engaged, Draper Header Index Switch ON</li> <li>• Cab Forward, Engine Running, Header Engaged, Rotary Header Installed</li> </ul>	<ul style="list-style-type: none"> <li>• <a href="#">Engine-Forward, Engine Running, page 82</a></li> <li>• <a href="#">Cab-Forward, Engine Running, Header Disengaged, page 82</a></li> <li>• <a href="#">Cab-Forward, Engine Running, Header Engaged, Auger Header Index Switch OFF, page 83</a></li> <li>• <a href="#">Cab-Forward, Engine Running, Header Engaged, Auger Header Index Switch ON, page 84</a></li> <li>• <a href="#">Cab-Forward, Engine Running, Header Engaged, Draper Header, Index Switch OFF, page 85</a></li> <li>• <a href="#">Cab-Forward, Engine Running, Header Engaged, Draper Header Index Switch ON, page 86</a></li> <li>• <a href="#">Cab-Forward, Engine Running, Header Engaged, Rotary Header Installed, page 87</a></li> </ul>
Updated radio information	<ul style="list-style-type: none"> <li>• <a href="#">3.14.1 AM/FM Radio, page 62</a></li> </ul>



# Serial Number

If you require MacDon technical assistance, please have the serial number recorded and ready before you call. Record the model number, model year, and serial number of the windrower and engine on the lines below.

The windrower serial number plate (A) is located on the left side of the main frame near the walking beam.

Windrower model number \_\_\_\_\_  
Windrower serial number \_\_\_\_\_  
Year of manufacture \_\_\_\_\_

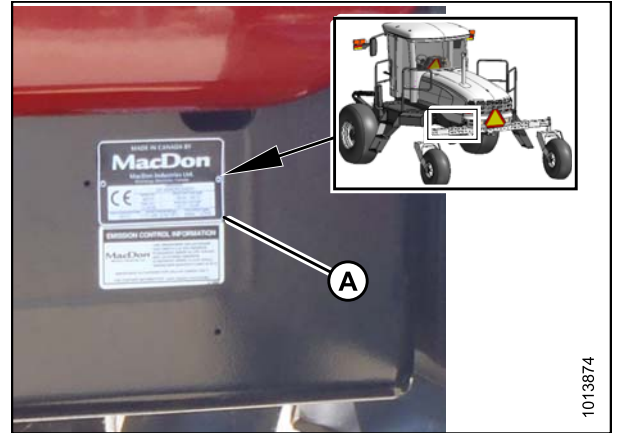

**Figure 3: Machine Serial Number Location**

The engine serial number plate (A) is located on top of the engine cylinder head cover.

Engine serial number \_\_\_\_\_  
Date of manufacture \_\_\_\_\_

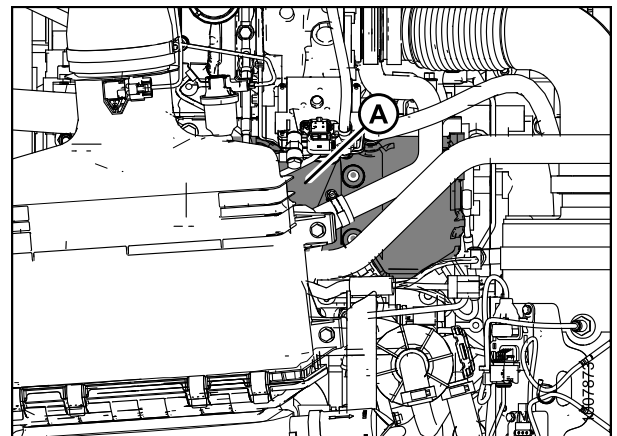

**Figure 4: Engine Serial Number Location**



## TABLE OF CONTENTS

Declaration of Conformity .....	i
Whole Body and Hand-Arm Vibration Levels .....	iii
Noise Levels .....	iii
Introduction .....	iv
List of Revisions .....	v
Serial Number .....	vii
<b>1 Safety .....</b>	<b>1</b>
1.1 Safety Alert Symbols .....	1
1.2 Signal Words .....	2
1.3 General Safety .....	3
1.4 Maintenance Safety .....	5
1.5 Hydraulic Safety .....	6
1.6 Tire Safety .....	7
1.7 Battery Safety .....	8
1.8 Welding Precaution .....	9
1.9 Engine Safety .....	10
1.9.1 High Pressure Rails .....	10
1.9.2 Engine Electronics .....	11
1.10 Safety Signs .....	12
1.10.1 Installing Safety Decals .....	12
1.11 Safety Sign Locations .....	13
1.12 Understanding Safety Signs .....	17
<b>2 Product Overview .....</b>	<b>27</b>
2.1 Definitions .....	27
2.2 Specifications .....	30
2.3 Windrower Dimensions .....	34
2.4 Component Location .....	36
<b>3 Operator's Station .....</b>	<b>39</b>
3.1 Operator Console .....	39
3.2 Operator Presence System .....	41
3.2.1 Header Drive .....	41
3.2.2 Engine and Transmission .....	41
3.3 Operator's Seat Adjustments .....	42
3.3.1 Fore-Aft .....	42
3.3.2 Seat Suspension and Height .....	42
3.3.3 Vertical Dampener .....	43
3.3.4 Armrest .....	43
3.3.5 Fore-Aft Isolator Lock .....	44
3.3.6 Seat Tilt .....	44
3.3.7 Armrest Angle .....	45
3.3.8 Lumbar Support .....	45
3.4 Training Seat .....	46
3.5 Seat Belts .....	47
3.6 Steering Column Adjustment .....	48
3.7 Lighting .....	49
3.7.1 Field Light: Cab-Forward .....	49
3.7.2 Road Light: Engine-Forward .....	50
3.7.3 Road Light: Cab-Forward .....	51
3.7.4 Hazard Light .....	52
3.7.5 Beacon Light .....	53
3.7.6 Auto Road Light .....	53
3.8 Windshield Wipers .....	54
3.9 Rear View Mirrors .....	55

## TABLE OF CONTENTS

---

3.10	Cab Temperature .....	56
3.10.1	Heater Shut-Off .....	56
3.10.2	Air Distribution .....	56
3.10.3	Climate Controls .....	57
3.11	Interior Lights .....	58
3.12	Emergency Exit .....	59
3.13	Operator Amenities .....	60
3.14	Radio .....	62
3.14.1	AM/FM Radio .....	62
3.14.2	Antenna Mounting .....	62
3.15	Horn .....	64
3.16	Engine Controls and Display Module .....	65
3.16.1	Fuel and Diesel Exhaust Fluid (DEF) Display Module .....	66
	Tools Menu .....	68
	Audible Alarm .....	70
3.17	Windrower Controls .....	71
3.18	Header Controls .....	73
3.18.1	Header Drive Switch .....	73
3.18.2	Header Drive Reverse Button .....	73
3.18.3	Ground Speed Lever (GSL) Header Switches .....	74
	Display Selector Switch .....	75
	Reel Position Switches .....	75
	Header Position Switches .....	76
	Reel and Disc Speed Switches .....	76
3.18.4	Console Header Switches .....	77
	Deck Shift/Float Preset Switch .....	77
	Double Windrow Attachment (DWA) / Swath Roller Switch (if installed) .....	78
3.19	Cab Display Module (CDM) .....	79
3.19.1	Engine and Windrower Functions .....	79
3.19.2	Header Functions .....	80
3.19.3	Operating Screens .....	81
	Ignition ON, Engine Not Running .....	81
	Engine-Forward, Engine Running .....	82
	Cab-Forward, Engine Running, Header Disengaged .....	82
	Cab-Forward, Engine Running, Header Engaged, Auger Header Index Switch OFF .....	83
	Cab-Forward, Engine Running, Header Engaged, Auger Header Index Switch ON .....	84
	Cab-Forward, Engine Running, Header Engaged, Draper Header, Index Switch OFF .....	85
	Cab-Forward, Engine Running, Header Engaged, Draper Header Index Switch ON .....	86
	Cab-Forward, Engine Running, Header Engaged, Rotary Header Installed .....	87
	Miscellaneous Operational Information .....	88
3.19.4	Cab Display Module (CDM) Warning/Alarms .....	89
	Engine Warning Lights .....	89
	Display Warnings and Alarms .....	90
3.19.5	Programming Guidelines .....	92
3.19.6	Cab Display Module (CDM) Programming .....	93
3.19.7	Cab Display Options .....	94
	Setting the Cab Display Language .....	94
	Changing the Windrower Display Units .....	95
	Adjusting the Cab Display Buzzer Volume .....	96
	Adjusting the Cab Display Backlighting .....	97
	Adjusting the Cab Display Contrast .....	98
3.19.8	Calibrating the Header Sensors .....	99
	Calibrating the Header Height Sensor .....	99
	Calibrating the Header Tilt Sensor .....	102

## TABLE OF CONTENTS

	Calibrating the Header Float Sensors .....	104
3.19.9	Programming the Windrower .....	106
	Activating the Hydraulic Center-Link .....	106
	Activating the Rotary Header Drive Hydraulics .....	106
	Setting the Header Knife Speed .....	107
	Setting the Knife Overload Speed .....	108
	Setting the Rotary Disc Overload Speed .....	109
	Setting the Hydraulic Overload Pressure .....	110
	Setting the Header Index Mode .....	111
	Setting the Return to Cut Mode .....	112
	Setting the Header Cut Width .....	113
	Activating the Double Windrow Attachment (DWA) .....	113
	Setting the Auto Raise Height .....	115
	Activating the Hay Conditioner .....	116
	Displaying Reel Speed .....	117
	Setting the Windrower's Tire Size .....	118
	Setting the Engine Intermediate Speed Control (ISC) RPM .....	119
	Clearing Sub-Acres .....	120
3.19.10	Activating Cab Display Lock Outs .....	120
	Activating Knife Speed Control Lock Out .....	120
	Activating Rotary Disc Speed Control Lock Out .....	121
	Activating the Header Float Control Lock Out .....	122
	Activating the Draper Speed Control Lock Out .....	124
	Activating the Auger Speed Control Lock Out .....	125
	Activating the Reel Speed Control Lock Out .....	126
	Activating the Reel Fore-Aft Control Lock Out .....	127
	Activating the Header Tilt Control Lock Out .....	128
3.19.11	Displaying Activated Cab Display Lock Outs .....	130
3.19.12	Troubleshooting Windrower Problems .....	131
	Displaying the Windrower and Engine Error Codes .....	131
	Switching the Installed Header Sensors On or Off .....	133
	Displaying Header Sensor Input Signals .....	134
	Forcing a Header ID .....	136
3.19.13	Troubleshooting Header Problems .....	137
	Testing the Header Up/Down Activate Function Using the Cab Display Module (CDM) .....	137
	Testing the Reel Up/Down Activate Function Using the Cab Display Module (CDM) .....	139
	Testing the Header Tilt Activate Function Using the Cab Display Module (CDM) .....	141
	Testing the Reel Fore-Aft Activate Function Using the Cab Display Module (CDM) .....	142
	Activating the Hydraulic Purge Using the Cab Display Module (CDM) .....	143
	Testing the Knife Drive Circuit Using the Cab Display Module (CDM) .....	145
	Testing the Draper Drive Circuit Activate Function Using the Cab Display Module (CDM) .....	147
	Testing the Reel Drive Circuit Activate Function Using the Cab Display Module (CDM) .....	149
	Testing the Rotary Disc Drive Circuit Activate Function Using the Cab Display Module (CDM) .....	150
	Testing the Double Windrower Attachment (DWA) Drive Activate Function Using the Cab Display Module (CDM) .....	152
3.19.14	Engine Error Codes .....	154
3.19.15	Cab Display Module (CDM) and Windrower Control Module (WCM) Fault Codes .....	154
<b>4</b>	<b>Operation .....</b>	<b>155</b>
4.1	Owner/Operator Responsibilities .....	155
4.2	Symbol Definitions .....	156

## TABLE OF CONTENTS

---

4.2.1	Engine Functions .....	156
4.2.2	Diesel Exhaust Fluid (DEF) Display .....	157
4.2.3	Windrower Operating Symbols .....	158
4.2.4	Header Functions .....	159
4.3	Operating the Windrower .....	160
4.3.1	Operational Safety .....	160
4.3.2	Break-In Period .....	161
4.3.3	Preseason Checks/Annual Service .....	161
	Air Conditioning Compressor Coolant Cycling .....	162
4.3.4	Daily Checks and Maintenance .....	162
4.3.5	Engine Operation .....	163
	Starting the Engine .....	163
	Engine Warmup .....	165
	Engine Intermediate Speed Control (ISC) .....	166
	Shutting Down the Engine .....	166
	Engine Temperature .....	167
	Engine Oil Pressure .....	167
	Electrical .....	167
	Engine Warning Lights .....	167
4.3.6	Diesel Exhaust Fluid (DEF) .....	168
	Filling the Diesel Exhaust Fluid (DEF) Tank .....	168
4.3.7	Driving the Windrower .....	169
	Entering and Exiting the Windrower .....	170
	Driving Forward in Cab-Forward Mode .....	171
	Driving Reverse in Cab-Forward Mode .....	172
	Driving Forward in Engine-Forward Mode .....	173
	Driving in Reverse in Engine-Forward Mode .....	175
	Spin Turning .....	176
	Stopping .....	176
4.3.8	Adjusting Caster Tread Width .....	177
4.3.9	Transporting .....	179
	Driving on the Road .....	179
	Towing Header with Windrower .....	182
	Towing the Windrower (Emergency) .....	191
	Final Drives .....	192
4.3.10	Storing the Windrower .....	192
4.4	Operating with a Header .....	194
4.4.1	Header Safety Props .....	194
4.4.2	Header Float .....	196
	Float Operating Guidelines .....	196
	Checking Float .....	196
	Float Options .....	199
4.4.3	Levelling the Header .....	200
4.4.4	Header Drive .....	203
	Engaging and Disengaging the Header .....	203
	Reversing the Header .....	204
4.4.5	Adjusting Header Angle .....	204
	Checking Self-Locking Center-Link Hook .....	205
4.4.6	Cutting Height .....	207
	Return to Cut .....	207
	Auto Raise Height .....	210
	Header Drop Rate .....	211
4.4.7	Double Windrowing .....	212
	Double Windrow Attachment (DWA) Deck Position .....	212

## TABLE OF CONTENTS

	Double Windrow Attachment (DWA) Draper Speed .....	213
4.4.8	Swath Roller Operation .....	213
4.5	Attaching and Detaching Headers .....	214
4.5.1	Attaching a D-Series Header .....	214
	Attaching Header Boots .....	214
	Attaching a D-Series Header: Hydraulic Center-Link with Optional Self-Alignment .....	215
	Attaching a D-Series Header: Hydraulic Center-Link without Self-Alignment .....	220
4.5.2	Detaching a D-Series Header .....	226
	Detaching a D-Series Header: Hydraulic Center-Link .....	226
4.5.3	Attaching an A-Series Header .....	229
	Attaching an A-Series Header: Hydraulic Center-Link with Optional Self-Alignment .....	230
	Attaching an A-Series Header: Hydraulic Center-Link without Self-Alignment .....	235
4.5.4	Detaching an A-Series Header .....	241
	Detaching an A-Series Header: Hydraulic Center-Link .....	241
4.5.5	Attaching an R-Series Header .....	244
	Attaching an R-Series Header: Hydraulic Center-Link with Optional Self-Alignment .....	244
	Attaching an R-Series Header: Hydraulic Center-Link without Self-Alignment .....	250
4.5.6	Detaching an R-Series Header .....	255
	Detaching an R-Series Header: Hydraulic Center-Link .....	255
4.6	Operating with a D-Series Header .....	259
4.6.1	Configuring Hydraulics .....	259
4.6.2	Header Position .....	260
4.6.3	Adjusting the Reel Fore-Aft Position .....	260
4.6.4	Adjusting the Reel Height .....	260
4.6.5	Reel Speed .....	260
	Setting Reel to Ground Speed .....	260
	Setting the Reel Only Speed .....	262
4.6.6	Draper Speed .....	263
	Setting Draper to Ground Speed .....	263
	Setting Draper Minimum Speed .....	264
	Setting Draper Index .....	265
	Setting Draper Speed Independent of Ground Speed .....	266
4.6.7	Knife Speed .....	267
	Setting Knife Speed "On the Go" .....	268
4.6.8	Deck Shift Control .....	269
	Deck Shift .....	269
	Setting Float Options with Deck Shift .....	269
4.7	Operating with an A-Series Header .....	272
4.7.1	Auger Speed .....	272
	Auger Speed on A30-D Headers .....	272
	Setting the Auger Speed on A40-D Headers .....	272
4.7.2	Displaying Reel Speed: A30-S and A30-D Headers .....	273
4.7.3	Reel Speed .....	274
	Reel Speed on A40-D Headers .....	274
4.7.4	Knife Speed .....	278
	Setting Knife Speed "On the Go" .....	279
4.8	Operating with an R-Series Header .....	280
4.8.1	Disc Speed .....	280
	Setting Disc Speed .....	281
<b>5</b>	<b>Maintenance and Servicing .....</b>	<b>283</b>
5.1	Preparation for Servicing .....	283
5.2	Engine Compartment Hood .....	284
5.2.1	Opening Hood (Lower Position) .....	284
5.2.2	Closing Hood (Lower Position) .....	285

## TABLE OF CONTENTS

---

5.2.3	Opening Hood (Highest Position) .....	285
5.2.4	Closing Hood (Highest Position).....	286
5.3	Maintenance Platforms .....	287
5.3.1	Opening Platforms (Standard Position).....	287
5.3.2	Closing Platforms (Standard Position).....	288
5.3.3	Opening Platforms (Major Service Position) .....	289
5.3.4	Closing Platforms (Major Service Position).....	290
5.4	Windrower Lubrication .....	292
5.4.1	Lubricating the Windrower .....	292
5.4.2	Lubrication Points.....	293
5.5	Operator's Station.....	294
5.5.1	Seat Belts .....	294
5.5.2	Safety Systems .....	294
	Checking Operator Presence System.....	294
	Checking Engine Interlock .....	295
5.5.3	Ground Speed Lever (GSL) Adjustments .....	295
	Adjusting Ground Speed Lever (GSL) Lateral Movement.....	295
	Adjusting Ground Speed Lever (GSL) Fore-Aft Movement.....	296
5.5.4	Steering Adjustments .....	297
	Checking Steering Link Pivots .....	297
	Checking and Adjusting Steering Chain Tension .....	299
5.5.5	Cab Suspension Limit Straps .....	300
5.6	Heating, Ventilating, and Air Conditioning (HVAC) System.....	301
5.6.1	Fresh Air Intake Filter .....	301
	Removing Fresh Air Filter.....	301
	Inspecting and Cleaning Fresh Air Filter Element.....	301
	Installing Fresh Air Filter.....	302
5.6.2	Return Air Cleaner/Filter .....	303
	Replacing Return Air Cleaner/Filter.....	303
	Cleaning Return Air Cleaner/Filter.....	304
5.6.3	Air Conditioning Condenser .....	304
5.6.4	Air Conditioning (A/C) Evaporator Core .....	304
	Removing Air Conditioning (A/C) Cover.....	305
	Cleaning Air Conditioning (A/C) Evaporator Core.....	305
	Installing Air Conditioning (A/C) Cover.....	306
5.6.5	Air Conditioning (A/C) Compressor.....	307
	Servicing the Air Conditioning Compressor.....	308
5.7	Engine.....	309
5.7.1	General Engine Inspection.....	309
5.7.2	Turning the Engine Manually.....	309
5.7.3	Checking Engine Oil Level.....	311
5.7.4	Changing Engine Oil.....	312
	Draining Engine Oil.....	312
	Replacing Engine Oil Filter .....	313
	Adding Engine Oil.....	313
5.7.5	Air Intake System .....	314
	Removing Primary Air Filter.....	315
	Installing Primary Air Filter.....	317
	Cleaning the Engine Air Cleaner's Primary Filter.....	319
	Replacing the Secondary Air Filter .....	319
5.7.6	Charge Air Cooling .....	321
5.7.7	Fuel System.....	321
	Replacing Fuel Tank Vent Filter .....	321
	Maintaining Fuel Filters .....	322



## TABLE OF CONTENTS

---

	Draining Fuel Tank.....	325
	Filling the Fuel Tank.....	327
	Fuel/Water Separator.....	328
5.7.8	Diesel Exhaust Fluid (DEF) System.....	330
	Draining the Diesel Exhaust Fluid (DEF) Tank.....	330
	Refilling the Diesel Exhaust Fluid (DEF) Tank.....	331
	Replacing the Diesel Exhaust Fluid (DEF) Vent Hose Filter.....	331
	Supply Module Filter.....	334
5.7.9	Engine Cooling System.....	337
	Checking Coolant Level.....	337
	Checking Engine Coolant Strength.....	338
	Inspecting Pressurized Coolant Tank Cap.....	338
	Changing Coolant.....	339
5.7.10	Gearbox.....	342
	Checking Lubricant Level and Adding Lubricant.....	342
	Changing Lubricant.....	343
5.7.11	Inspecting Exhaust System.....	344
5.7.12	Belts.....	345
	Tensioning Alternator/Fan Belt.....	345
	Replacing Fan Belt.....	345
	Tensioning Air Conditioner (A/C) Compressor Belt.....	347
	Replacing Air Conditioner (A/C) Compressor Belt.....	347
5.7.13	Engine Speed.....	348
	Throttle Adjustment.....	348
5.8	Maintaining Engine Cooling Box.....	349
5.8.1	Opening Cooler Box Screen.....	349
5.8.2	Cleaning Screens and Coolers.....	349
5.8.3	Cleaning Cooler Box Components.....	350
5.8.4	Adjusting Screen Cleaner Rotor to Screen Clearance.....	353
5.8.5	Closing Cooler Box Screen.....	353
5.9	Electrical System.....	354
5.9.1	Preventing Electrical System Damage.....	354
5.9.2	Battery.....	354
	Maintaining the Battery.....	354
	Battery Main Disconnect Switch.....	355
	Charging the Battery.....	356
	Boosting the Battery.....	358
	Adding Electrolyte to the Battery.....	358
	Removing Batteries.....	359
	Installing Batteries.....	360
	Connecting Batteries.....	361
5.9.3	Headlights: Engine-Forward.....	362
	Aligning Headlights.....	362
	Replacing Headlight Bulb.....	364
5.9.4	Field Lights: Cab-Forward.....	366
	Adjusting Field Lights.....	366
	Replacing Field Light Bulb.....	367
5.9.5	Flood Lights: Forward.....	367
	Adjusting Forward Flood Lights.....	367
	Replacing Bulb in Cab-Forward Flood Light.....	367
5.9.6	High-Intensity Discharge (HID) Auxiliary Lighting (Optional - MD #B5596).....	369
	Replacing High-Intensity Discharge (HID) Auxiliary Lights (if Installed).....	369
	Adjusting High-Intensity Discharge (HID) Auxiliary Lights (if Installed).....	372
5.9.7	Flood Lights: Rear.....	372

## TABLE OF CONTENTS

	Adjusting Rear Flood Lights.....	372
	Replacing Bulb in Rear Flood Light.....	373
5.9.8	Replacing Bulbs in Red and Amber Lights.....	374
5.9.9	Replacing Red Tail Lights (if installed).....	375
5.9.10	Replacing the Bulbs in Beacon Lights.....	375
5.9.11	Replacing the Cabin Dome Light.....	379
5.9.12	Replacing the Ambient Light Fixture.....	380
5.9.13	Turn Signal Indicators.....	381
5.9.14	Accessing Circuit Breakers and Fuses.....	381
	Checking and Replacing Fuses.....	381
	Replacing Circuit Breakers and Relays.....	382
	Fuse Box Decal.....	383
	Accessing T4 Specific Fuses.....	384
	Inspecting and Replacing 125A Main Fuses.....	385
5.10	Hydraulic System.....	388
5.10.1	Checking and Filling Hydraulic Oil.....	389
5.10.2	Hydraulic Oil Cooler.....	390
5.10.3	Draining Hydraulic Oil.....	390
5.10.4	Changing Hydraulic Oil Filters.....	391
	Charge Oil Filter.....	392
	Return Oil Filter.....	393
5.10.5	Header and Reel Hydraulics.....	394
	Pressure Compensator Valve.....	394
	Flow Control Blocks.....	395
	Adjusting Header Drop Rate.....	395
	Adjusting Reel Drop Rate.....	396
5.10.6	Traction Drive Hydraulics.....	397
	Checking Transmission Oil Pressure.....	397
	Checking Charge Pump Pressure.....	398
5.10.7	Hoses and Lines.....	399
5.11	Wheels and Tires.....	400
5.11.1	Drive Wheel.....	400
	Inflating Drive Wheel Tire.....	400
	Tightening Drive Wheel Nuts.....	401
	Servicing Drive Wheel.....	401
	Lubrication.....	404
5.11.2	Caster Wheel.....	406
	Inflating Caster Tire.....	406
	Tightening Caster Wheel Nuts.....	407
	Servicing Caster Wheels.....	408
	Tightening Caster Wheel Anti-Shimmy Dampeners.....	412
	Ballast Requirements.....	413
5.12	Maintenance Schedule.....	414
5.12.1	Maintenance Schedule/Record.....	414
<b>6</b>	<b>Options and Attachments.....</b>	<b>419</b>
6.1	Cab.....	419
6.1.1	AM/FM Radio.....	419
6.1.2	HID Auxiliary Lighting.....	419
6.1.3	Windshield Shades.....	419
6.1.4	Automated Steering Systems.....	419
6.2	Header Operation.....	420
6.2.1	Booster Spring Kit (External).....	420
6.2.2	Booster Spring Kit (Internal).....	420
6.2.3	Light Header Flotation.....	420

## TABLE OF CONTENTS

6.2.4	Double Windrow Attachment (DWA)	420
6.2.5	Draper Header Reel Drive and Lift Plumbing	420
6.2.6	Draper Header Case Drain Kit	421
6.2.7	Header Drive Reverser	421
6.2.8	Self-Aligning Center-Link	421
6.2.9	Rotary Header Drive Hydraulics (13-foot)	421
6.2.10	Pressure Sensor Kit	421
6.2.11	Swath Roller	421
6.2.12	Valve for Driving Rotary Disc Header	422
6.3	Transport	423
6.3.1	Weight Box	423
6.3.2	Lighting and Marking for Cab-Forward Road Travel	423
6.3.3	Towing Harness	423
6.3.4	Transport Drawbar	423
6.4	Engine	424
6.4.1	Engine Block Heater	424
6.4.2	Engine Fan Air Baffle	424
<b>7</b>	<b>Troubleshooting</b>	<b>425</b>
7.1	Engine Troubleshooting	425
7.2	Electrical Troubleshooting	430
7.3	Hydraulics Troubleshooting	431
7.4	Header Drive Troubleshooting	432
7.5	Traction Drive Troubleshooting	433
7.6	Steering and Ground Speed Control Troubleshooting	436
7.7	Cab Air Troubleshooting	437
7.8	Operator's Station Troubleshooting	441
<b>8</b>	<b>Reference</b>	<b>443</b>
8.1	Recommended Fuel, Fluids, and Lubricants	443
8.1.1	Storing Lubricants and Fluids	443
8.1.2	Fuel Specifications	443
8.1.3	Lubricants, Fluids, and System Capacities	444
8.1.4	Filter Part Numbers	445
8.2	Recommended Torques	446
8.2.1	Torque Specifications	446
	SAE Bolt Torque Specifications	446
	Metric Bolt Specifications	448
	Metric Bolt Specifications Bolting into Cast Aluminum	451
	Flare-Type Hydraulic Fittings	451
	O-Ring Boss (ORB) Hydraulic Fittings (Adjustable)	453
	O-Ring Boss (ORB) Hydraulic Fittings (Non-Adjustable)	455
	O-Ring Face Seal (ORFS) Hydraulic Fittings	456
8.3	Conversion Chart	458
8.4	Engine Error Codes	459
8.5	Diesel Exhaust Fluid (DEF) Supply Module Fault Codes	483
8.6	Diesel Exhaust Fluid (DEF) Tank and Sensor Associated Fault Codes	485
8.7	Troubleshooting Diesel Exhaust Fluid (DEF) System	488
8.8	Cab Display Module (CDM)/Windrower Control Module (WCM) Error Codes	490
8.8.1	Cab Display Module (CDM) Error Codes	490
8.8.2	Miscellaneous Information / Error Codes	493
	<b>Index</b>	<b>495</b>



# 1 Safety

## 1.1 Safety Alert Symbols

This safety alert symbol indicates important safety messages in this manual and on safety signs on the .

This symbol means:

- **ATTENTION!**
- **BECOME ALERT!**
- **YOUR SAFETY IS INVOLVED!**

Carefully read and follow the safety message accompanying this symbol.

### Why is safety important to you?

- Accidents disable and kill
- Accidents cost
- Accidents can be avoided



Figure 1.1: Safety Symbol

## 1.2 Signal Words

Three signal words, *DANGER*, *WARNING*, and *CAUTION*, are used to alert you to hazardous situations. The appropriate signal word for each situation has been selected using the following guidelines:

### **DANGER**

Indicates an imminently hazardous situation that, if not avoided, will result in death or serious injury.

### **WARNING**

Indicates a potentially hazardous situation that, if not avoided, could result in death or serious injury. It may also be used to alert against unsafe practices.

### **CAUTION**

Indicates a potentially hazardous situation that, if not avoided, may result in minor or moderate injury. It may be used to alert against unsafe practices.

## 1.3 General Safety

### CAUTION

The following are general farm safety precautions that should be part of your operating procedure for all types of machinery.

Protect yourself.

- When assembling, operating, and servicing machinery, wear all the protective clothing and personal safety devices that **could** be necessary for the job at hand. Don't take chances. You may need the following:
  - Hard hat
  - Protective footwear with slip resistant soles
  - Protective glasses or goggles
  - Heavy gloves
  - Wet weather gear
  - Respirator or filter mask
- Be aware that exposure to loud noises can cause hearing impairment or loss. Wear suitable hearing protection devices such as ear muffs or ear plugs to help protect against objectionable or loud noises.

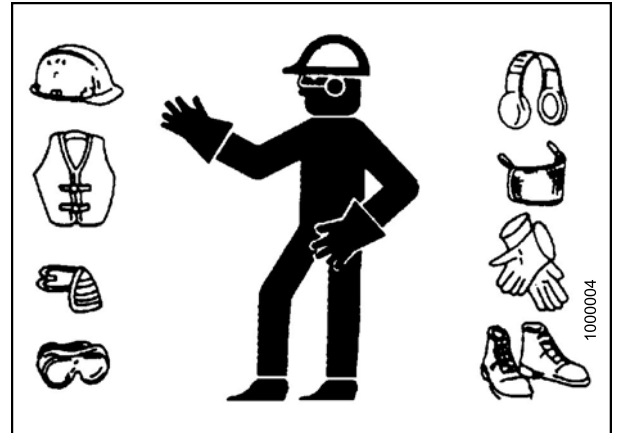

Figure 1.2: Safety Equipment



Figure 1.3: Safety Equipment

- Provide a first aid kit for use in case of emergencies.
- Keep a fire extinguisher on the machine. Be sure the fire extinguisher is properly maintained. Be familiar with its proper use.
- Keep young children away from the machinery at all times.
- Be aware that accidents often happen when the Operator is tired or in a hurry. Take the time to consider the safest way. Never ignore the warning signs of fatigue.

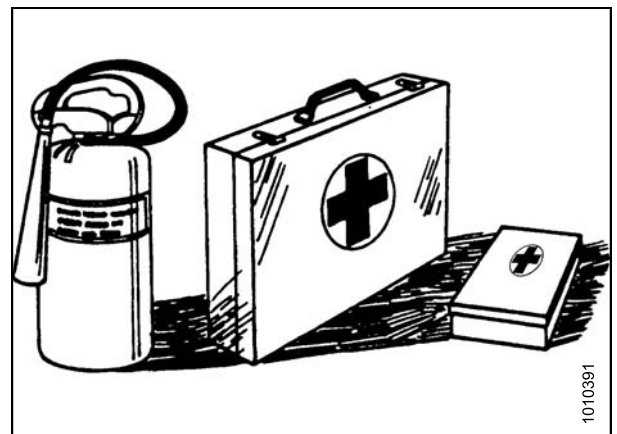

Figure 1.4: Safety Equipment

## SAFETY

- Wear close-fitting clothing and cover long hair. Never wear dangling items such as scarves or bracelets.
- Keep all shields in place. Never alter or remove safety equipment. Make sure driveline guards can rotate independently of the shaft and can telescope freely.
- Use only service and repair parts made or approved by the equipment manufacturer. Substituted parts may not meet strength, design, or safety requirements.



Figure 1.5: Safety around Equipment

- Keep hands, feet, clothing, and hair away from moving parts. Never attempt to clear obstructions or objects from a machine while the engine is running.
- Do **NOT** modify the machine. Non-authorized modifications may impair machine function and/or safety. It may also shorten the machine's life.
- To avoid bodily injury or death from unexpected startup of machine, always stop the engine and remove the key from ignition before leaving operator's seat for any reason.

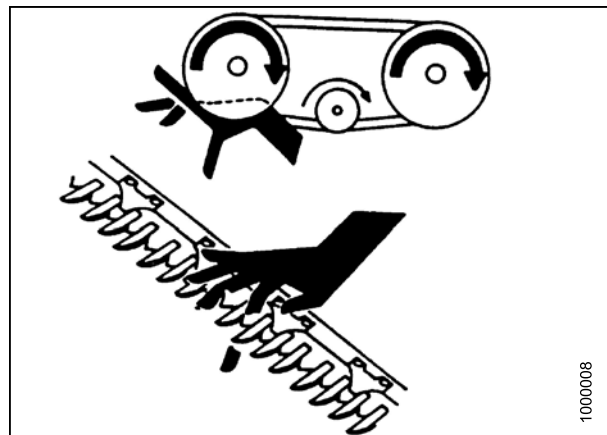

Figure 1.6: Safety around Equipment

- Keep the service area clean and dry. Wet or oily floors are slippery. Wet spots can be dangerous when working with electrical equipment. Be sure all electrical outlets and tools are properly grounded.
- Keep work area well lit.
- Keep machinery clean. Straw and chaff on a hot engine is a fire hazard. Do **NOT** allow oil or grease to accumulate on service platforms, ladders, or controls. Clean machines before storage.
- Never use gasoline, naphtha, or any volatile material for cleaning purposes. These materials may be toxic and/or flammable.
- When storing machinery, cover sharp or extending components to prevent injury from accidental contact.



Figure 1.7: Safety around Equipment



## 1.4 Maintenance Safety

To ensure your safety while maintaining the machine:

- Review the operator's manual and all safety items before operation and/or maintenance of the machine.
- Place all controls in Neutral, stop the engine, set the park brake, remove the ignition key, and wait for all moving parts to stop before servicing, adjusting, and/or repairing.
- Follow good shop practices:
  - Keep service areas clean and dry
  - Be sure electrical outlets and tools are properly grounded
  - Use adequate lighting for the job at hand
- Relieve pressure from hydraulic circuits before servicing and/or disconnecting the machine.
- Make sure all components are tight and that steel lines, hoses, and couplings are in good condition before applying pressure to hydraulic systems.
- Keep hands, feet, clothing, and hair away from all moving and/or rotating parts.
- Clear the area of bystanders, especially children, when carrying out any maintenance, repairs or, adjustments.
- Install transport lock or place safety stands under the frame before working under the .
- If more than one person is servicing the machine at the same time, be aware that rotating a driveline or other mechanically-driven component by hand (for example, accessing a lube fitting) will cause drive components in other areas (belts, pulleys, and knives) to move. Stay clear of driven components at all times.
- Wear protective gear when working on the machine.
- Wear heavy gloves when working on knife components.



**Figure 1.8: Safety around Equipment**

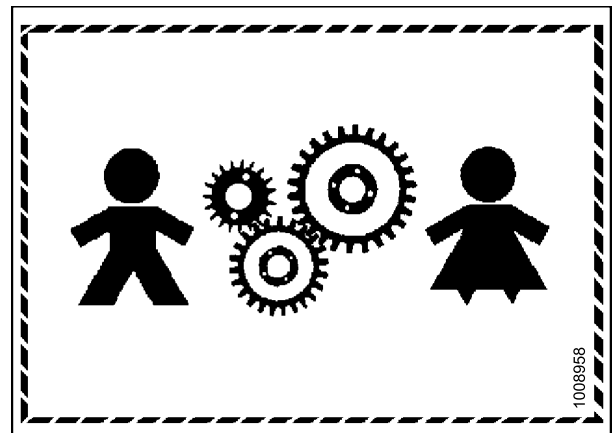

**Figure 1.9: Equipment NOT Safe for Children**

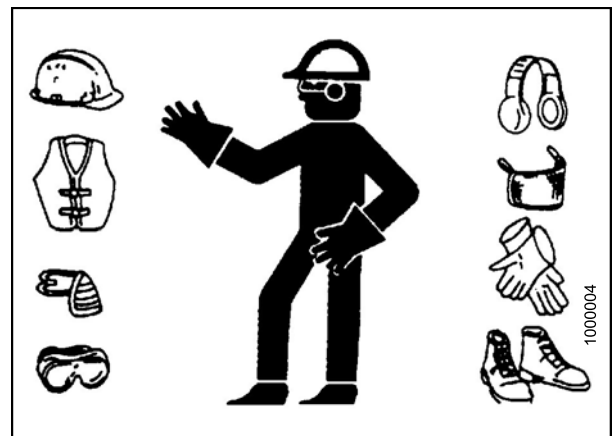

**Figure 1.10: Safety Equipment**

## 1.5 Hydraulic Safety

- Always place all hydraulic controls in Neutral before dismounting.
- Make sure that all components in the hydraulic system are kept clean and in good condition.
- Replace any worn, cut, abraded, flattened, or crimped hoses and steel lines.
- Do **NOT** attempt any makeshift repairs to the hydraulic lines, fittings, or hoses by using tapes, clamps, cements, or welding. The hydraulic system operates under extremely high pressure. Makeshift repairs will fail suddenly and create hazardous and unsafe conditions.

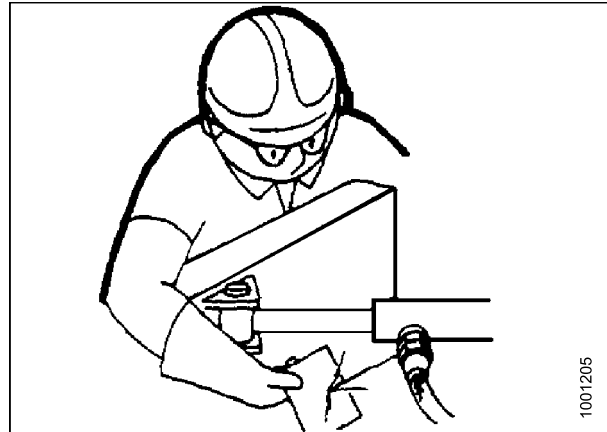

Figure 1.11: Testing for Hydraulic Leaks

- Wear proper hand and eye protection when searching for high-pressure hydraulic leaks. Use a piece of cardboard as a backstop instead of hands to isolate and identify a leak.
- If injured by a concentrated high-pressure stream of hydraulic fluid, seek medical attention immediately. Serious infection or toxic reaction can develop from hydraulic fluid piercing the skin.



Figure 1.12: Hydraulic Pressure Hazard

- Make sure all components are tight and steel lines, hoses, and couplings are in good condition before applying pressure to a hydraulic system.

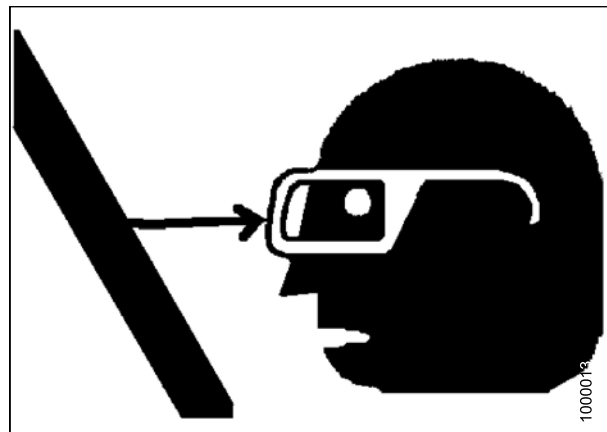

Figure 1.13: Safety around Equipment

## 1.6 Tire Safety

- Follow proper procedures when mounting a tire on a wheel or rim. Failure to do so can produce an explosion that may result in serious injury or death.

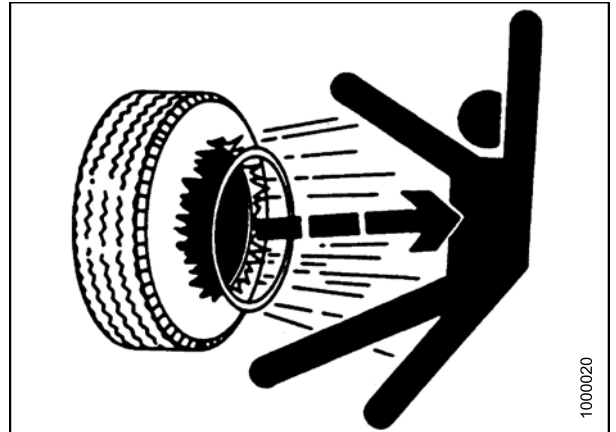

Figure 1.14: Overinflated Tire

- Do **NOT** attempt to mount a tire unless you have the proper training and equipment.
- Have a qualified tire dealer or repair service perform required tire maintenance.

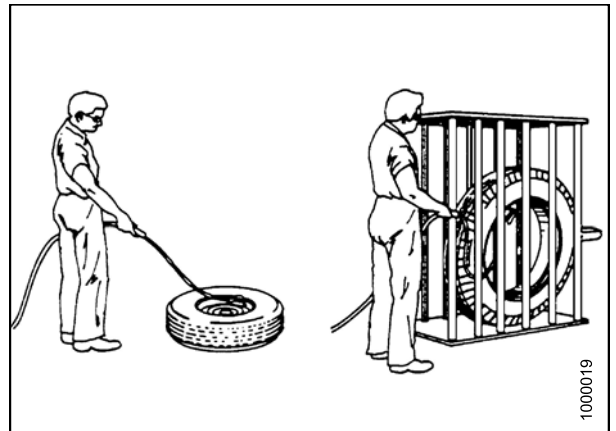

Figure 1.15: Safely Filling a Tire with Air

## 1.7 Battery Safety

### WARNING

- Keep all sparks and flames away from the batteries, as a gas given off by electrolyte is explosive.
- Ventilate when charging in enclosed space.

### WARNING

- Wear safety glasses when working near batteries.
- Do NOT tip batteries more than 45° to avoid electrolyte loss.
- Battery electrolyte causes severe burns. Avoid contact with skin, eyes, or clothing.
- Electrolyte splashed into the eyes is extremely dangerous. Should this occur, force the eye open, and flood with cool, clean water for five minutes. Call a doctor immediately.
- If electrolyte is spilled or splashed on clothing or the body, neutralize it immediately with a solution of baking soda and water, then rinse with clear water.

### WARNING

- To avoid injury from spark or short circuit, disconnect battery ground cable before servicing and part of electrical system.
- Do NOT operate the engine with alternator or battery disconnected. With battery cables disconnected and engine running, a high voltage can be built up if terminals touch the frame. Anyone touching the frame under these conditions would be severely shocked.
- When working around storage batteries, remember that all of the exposed metal parts are live. Never lay a metal object across the terminals because a spark or short circuit will result.
- Keep batteries out of reach of children.



Figure 1.16: Safety around Batteries

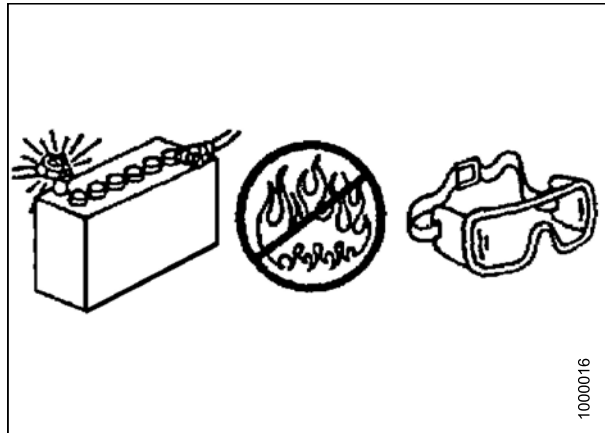

Figure 1.17: Safety around Batteries

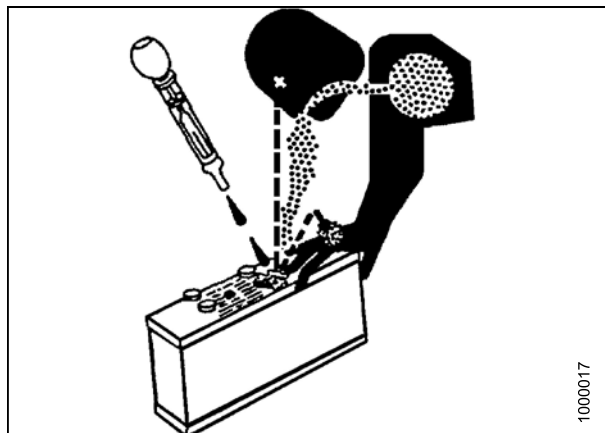

Figure 1.18: Safety around Batteries

## **1.8 Welding Precaution**

High currents and voltage spikes associated with welding can cause damage to electronic components. Before welding on any part of the windrower or an attached mower conditioner, disconnect all electronic module harness connections as well as the battery cables. Refer to your Dealer for proper procedures.

## 1.9 Engine Safety

### WARNING

Do NOT use aerosol types of starting aids such as ether. Such use could result in an explosion and personal injury.

### CAUTION

- In the initial start-up of a new, serviced, or repaired engine, always be ready to stop the engine in order to stop an over-speed. This may be accomplished by shutting off the air and/or fuel supply to the engine. Over-speed shut down should occur automatically for engines that are controlled electronically.
- Do NOT bypass or disable the automatic shutoff circuits. The circuits are provided in order to help prevent personal injury. The circuits are also provided in order to help prevent engine damage. Refer to your Dealer for repairs and adjustments.
- Inspect the engine for potential hazards.
- Before starting the engine, ensure that no one is on, underneath, or close to the engine. Ensure that people clear the area.
- All protective guards and all protective covers must be installed if the engine must be started in order to perform service procedures.
- To help prevent an accident that is caused by parts in rotation, work around the parts carefully.
- If a warning tag is attached to the engine start switch or to the controls, do NOT start the engine or move the controls. Consult with the person who attached the warning tag before the engine is started.
- Start the engine from the operator's compartment. Always start the engine according to the procedure that is described in the Starting the Engine section of the operator's manual. Knowing the correct procedure will help to prevent major damage to the engine components and prevent personal injury.
- To ensure that the jacket water heater (if equipped) and/or the lube oil heater (if equipped) is working correctly, check the water temperature gauge and/or the oil temperature gauge during the heater operation. Engine exhaust contains products of combustion which can be harmful to your health. Always start the engine and operate the engine in a well ventilated area. If the engine is started in an enclosed area, vent the engine exhaust to the outside.

#### NOTE:

The engine may be equipped with a device for cold starting. If the engine will be operated in very cold conditions, then an additional cold starting aid may be required. Normally, the engine will be equipped with the correct type of starting aid for your region of operation.

### 1.9.1 High Pressure Rails

#### CAUTION

Contact with high pressure fuel may cause fluid penetration and burn hazards. High pressure fuel spray may cause a fire hazard. Failure to follow these inspection, maintenance, and service instructions may cause personal injury or death.

## 1.9.2 Engine Electronics

### **WARNING**

Tampering with the electronic system installation or the original equipment manufacturer (OEM) wiring installation can be dangerous and could result in personal injury or death and/or engine damage.

### **WARNING**

**Electrical Shock Hazard.** The electronic unit injectors use DC voltage. The engine control module (ECM) sends this voltage to the electronic unit injectors. Do NOT come in contact with the harness connector for the electronic unit injectors while the engine is operating. Failure to follow this instruction could result in personal injury or death.

This engine has a comprehensive, programmable engine monitoring system. The ECM has the ability to monitor the engine operating conditions. If conditions exceed the allowable range, the ECM will initiate an immediate action.

The following actions are available for engine monitoring control:

- Warning
- Derate
- Shutdown

The following monitored engine operating conditions have the ability to limit engine speed and/or the engine power:

- Engine coolant temperature
- Engine oil pressure
- Engine speed
- Intake manifold air temperature
- Diesel exhaust fluid (DEF) system performance
- Aftertreatment system performance

## 1.10 Safety Signs

- Keep safety signs clean and legible at all times.
- Replace safety signs that are missing or become illegible.
- If original parts on which a safety sign was installed are replaced, be sure the repair part also bears the current safety sign.
- Safety signs are available from your Dealer Parts Department.

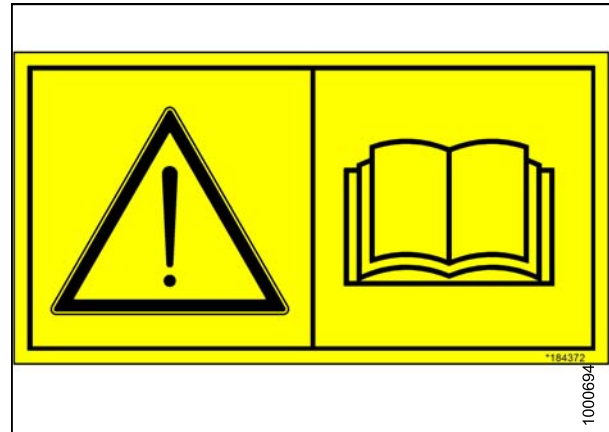

**Figure 1.19: Operator's Manual Decal**

### 1.10.1 Installing Safety Decals

1. Clean and dry the installation area.
2. Decide on the exact location before you remove the decal backing paper.
3. Remove the smaller portion of the split backing paper.
4. Place the sign in position and slowly peel back the remaining paper, smoothing the sign as it is applied.
5. Prick small air pockets with a pin and smooth out.



## 1.11 Safety Sign Locations

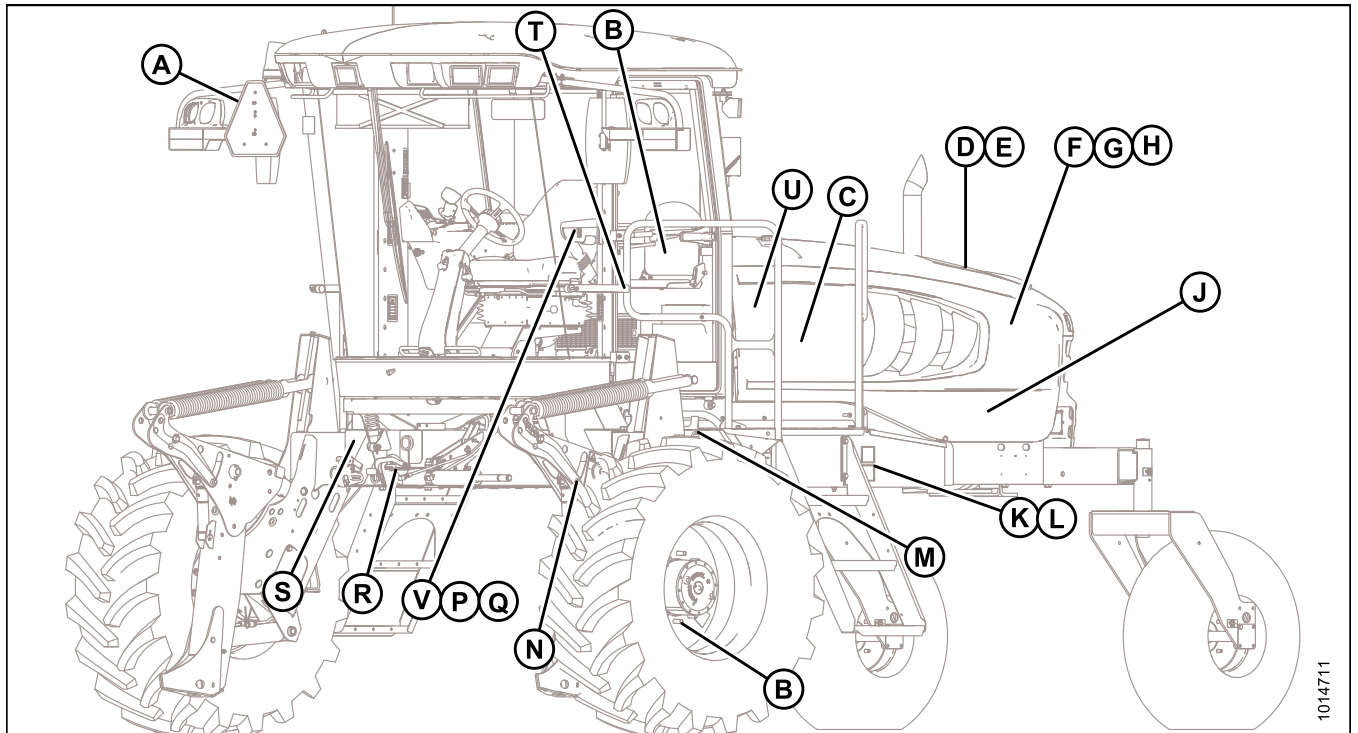

**Figure 1.20: Safety Sign Locations (Left-Hand Side)**

A - Hazard Sign (MD #135378)

D - Exhaust Cover (MD #166450)

G - Fan Shroud (Middle) (MD #166451)

K - Platform (Left of Step) (MD #166425)

N - Lift Linkage (MD #166438)

R - Neutral Interlock (MD #166425)

U - Air Baffle (MD #166450)

B - Cab Door and Rim (MD #166454)

E - Close to Radiator Cap (MD #166461)

H - Fan Shroud (Bottom) (MD #166452)

L - Platform (Right of Step) (MD #166441)

P - Inner Post (MD #166234)

S - Frame (MD #166425)

V - Inner Post (MD #166457)

C - Oil Reservoir under Hood (MD #166466)

F - Fan Shroud (Top) (MD #166450)

J - Frame Opening (MD #166233)

M - Frame at Valve Block (MD #166466)

Q - Inner Post (MD #166463)

T - Trainers Seat (MD #167502)

SAFETY

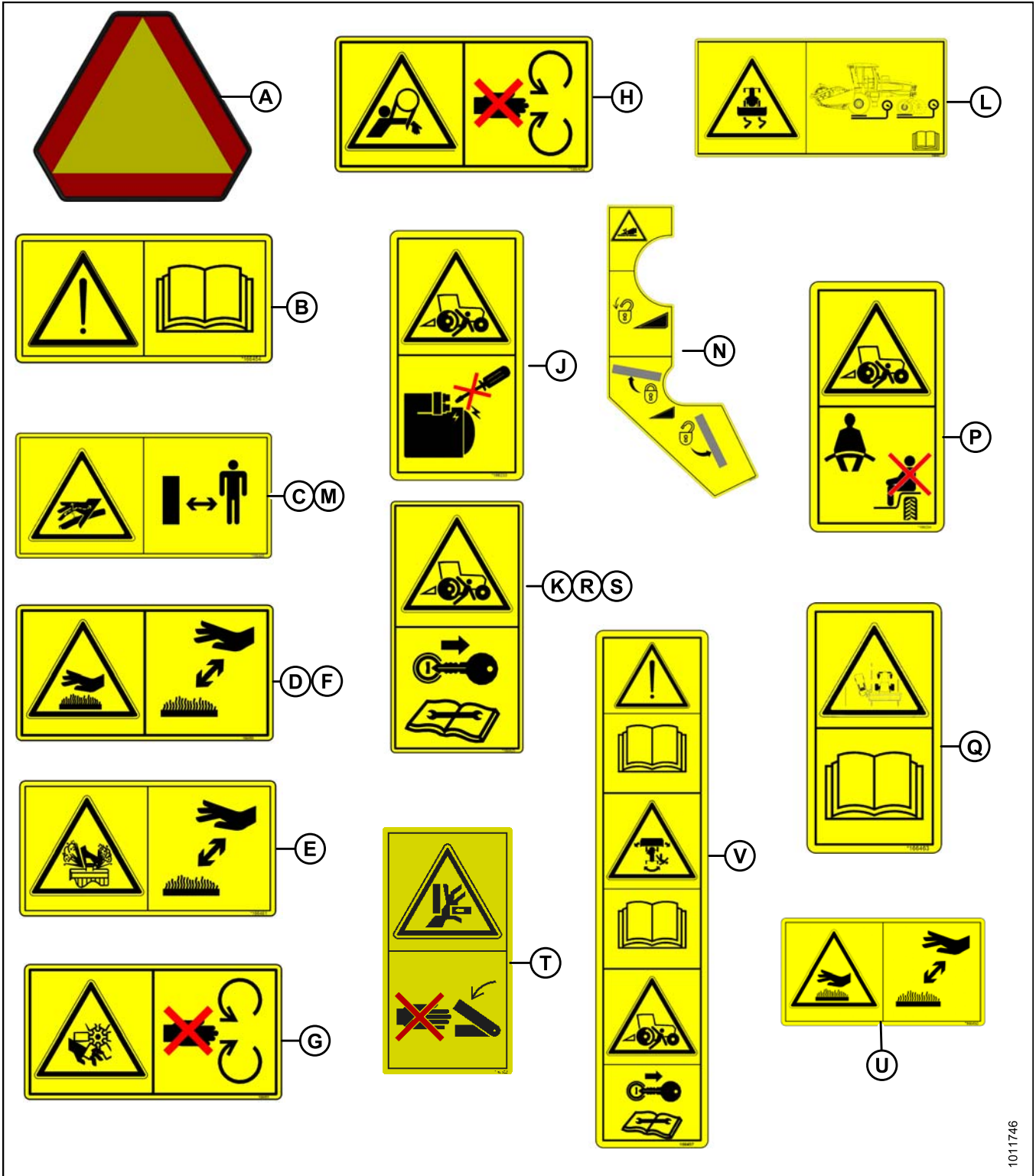

1011746

Figure 1.21: Safety Signs (Left-Hand Side)

## SAFETY

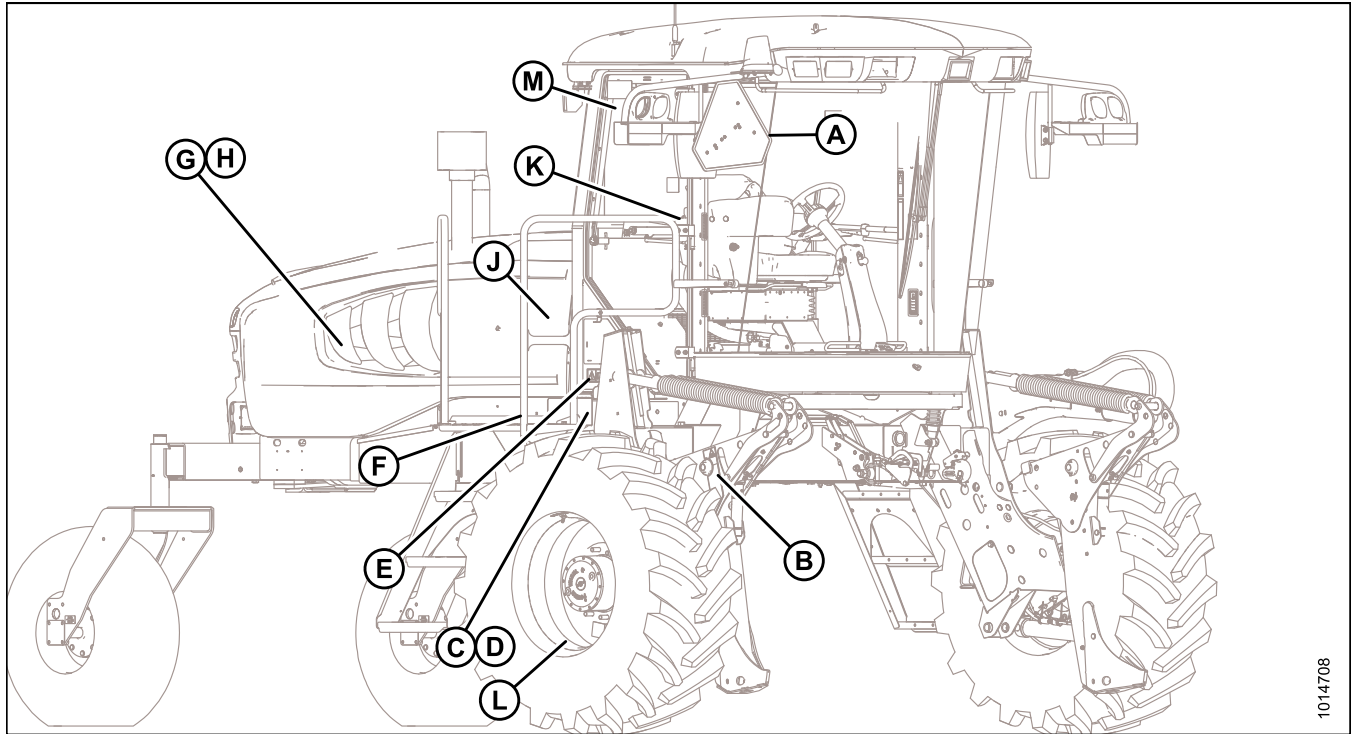

1014708

**Figure 1.22: Safety Sign Locations (Right-Hand Side)**

A - Hazard Sign on Seat (MD #115148)  
D - Frame (MD #166456)  
G - Shroud (MD #166451)  
K - Wiper Cover (MD #166465)

B - Lift Linkage (MD #166439)  
E - Cab Frame (MD #184372)  
H - Shroud (MD #166452)  
L - Rim (MD #166454 [similar to [E]])

C - Frame (MD #166455)  
F - Platform (MD #166425)  
J - Hydraulic Reservoir (MD #166466)  
M - Window (MD #167504)

SAFETY

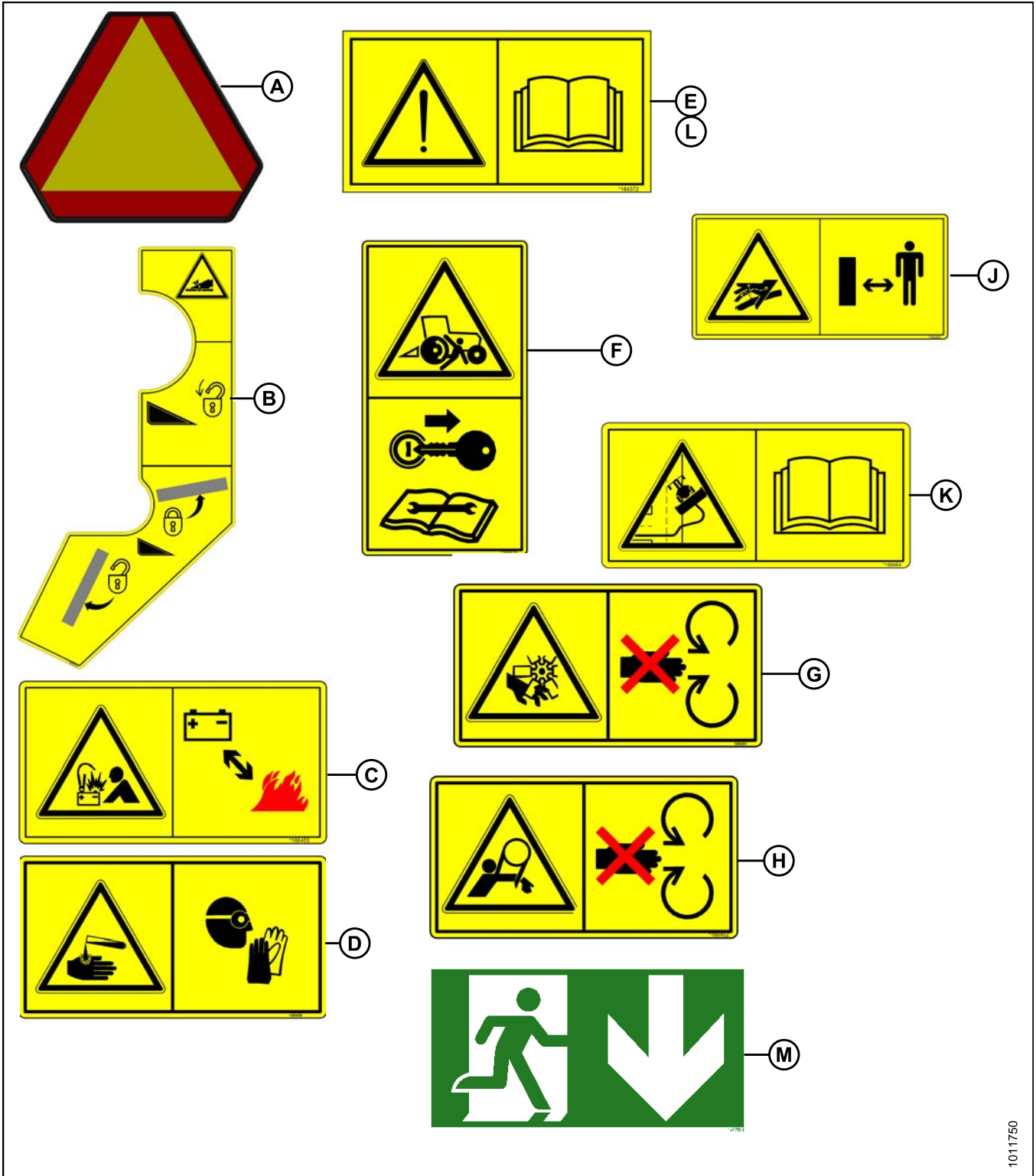

1011750

Figure 1.23: Safety Signs (Right-Hand Side)

## 1.12 Understanding Safety Signs

### MD #166233

Run-over hazard

#### DANGER

- Do not start engine by shorting across starter or starter relay terminals. Machine will start with drive engaged and move if starting circuitry is bypassed.
- Start engine only from operator's seat. Do not try to start engine with someone under or near machine.



Figure 1.24: MD #166233

### MD #166234

Run-over hazard

#### WARNING

- The training seat is provided for an experienced Operator of the machine when a new Operator is being trained.
- The training seat is not intended as a passenger seat or for use by children.
- Use the seat belt whenever operating the machine or riding as a trainer.
- Keep all other riders off the machine.



Figure 1.25: MD #166234

### MD #166425

Run-over hazard

#### WARNING

- Remove key from ignition.
- Read the tractor and mower manufacturer's manuals for inspection and maintenance instructions.
- Read the windrower and header manuals for inspection and maintenance instructions.



Figure 1.26: MD #166425

## SAFETY

### MD #166438

Crushing hazard

#### DANGER

- Rest header on ground or engage safety props before going under unit.

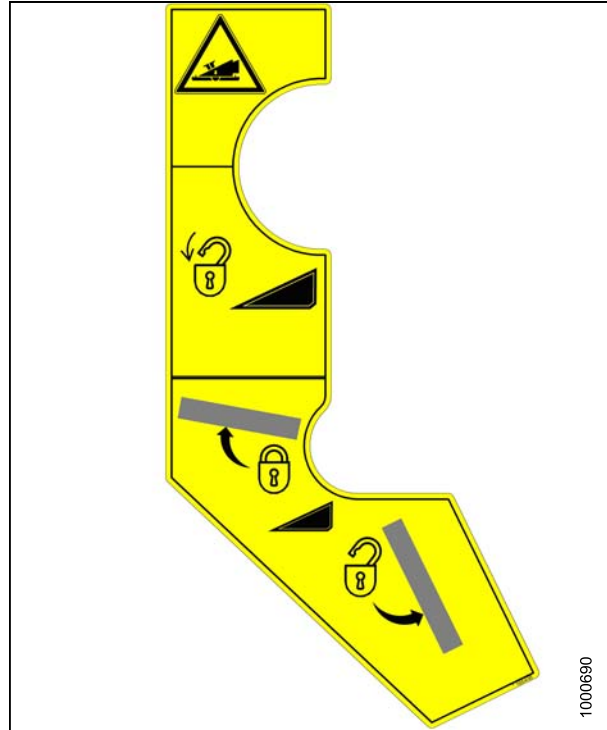

Figure 1.27: MD #166438

### MD #166439

Crushing hazard

#### DANGER

- Rest header on ground or engage safety props before going under unit.

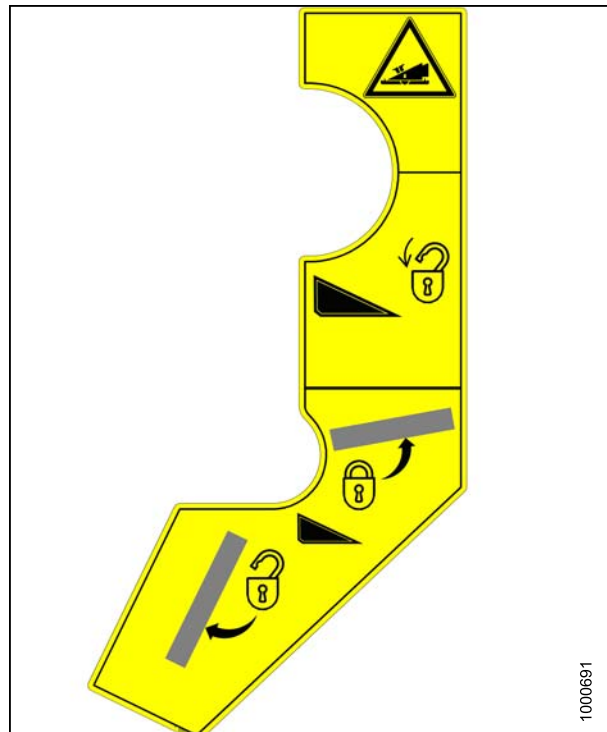

Figure 1.28: MD #166439

## SAFETY

### MD #166441

Loss of control hazard

#### CAUTION

- To prevent machine damage and/or loss of control, it is essential that the machine be equipped such that weights are within the specified limits.

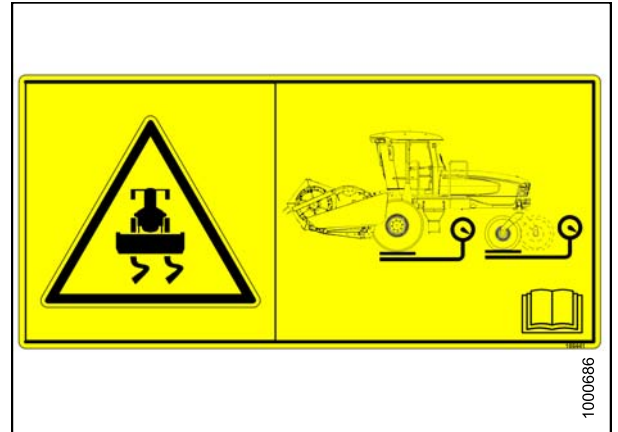

Figure 1.29: MD #166441

### MD #166450

Hot surface hazard

#### WARNING

- To avoid injury, keep a safe distance from hot surface.

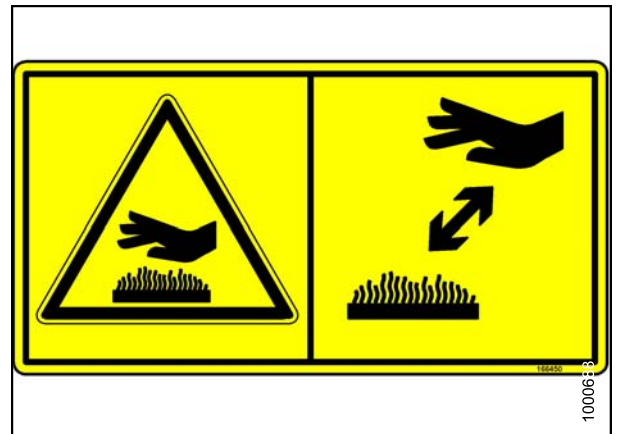

Figure 1.30: MD #166450

### MD #166451

Rotating fan hazard

#### WARNING

- To avoid injury, stop the engine and remove the key before opening engine hood.

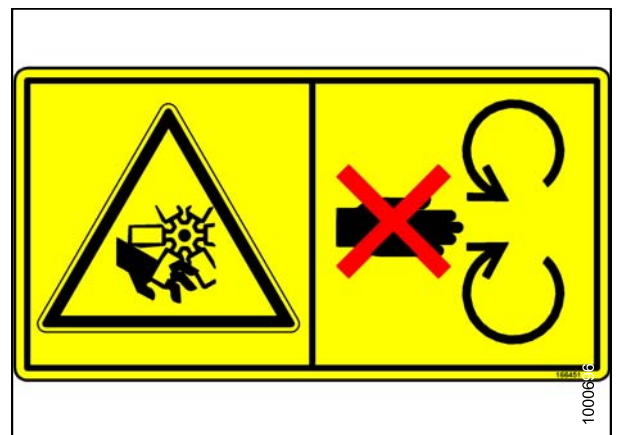

Figure 1.31: MD #166451

## SAFETY

### MD #166452

Pinch point hazard

#### WARNING

- To avoid injury, stop the engine and remove the key before opening engine hood.

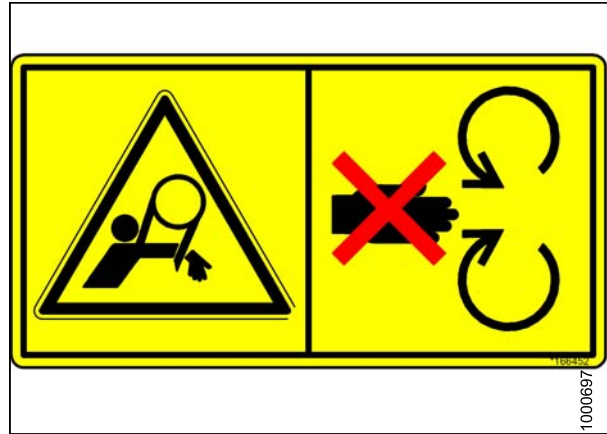

Figure 1.32: MD #166452

### MD #166454

General hazard pertaining to machine operation and servicing.

#### CAUTION

- Read the operator's manual and follow all safety instructions. If you do not have a manual, obtain one from your Dealer.
- Do not allow untrained persons to operate the machine.
- Review safety instructions with all Operators every year.
- Ensure that all safety signs are installed and legible.
- Make certain everyone is clear of machine before starting engine and during operation.
- Keep riders off the machine.
- Keep all shields in place and stay clear of moving parts.
- Disengage header drive, put transmission in Neutral, and wait for all movement to stop before leaving operator's position.
- Stop the engine and remove the key from ignition before servicing, adjusting, lubricating, cleaning, or unplugging machine.
- Engage locks to prevent lowering of header or reel before servicing in the raised position.
- Use slow moving vehicle emblem and flashing warning lights when operating on roadways unless prohibited by law.

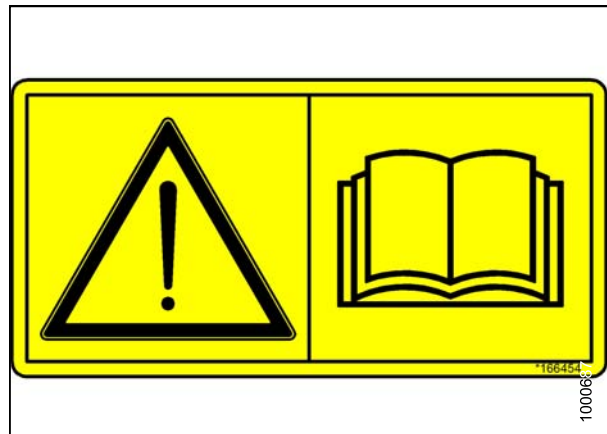

Figure 1.33: MD #166454



## SAFETY

### MD #166455

Explosion hazard

#### WARNING

- Prevent serious bodily injury caused by explosive battery gases.
- Keep sparks and flames away from the battery.
- Refer to operator's manual for battery boosting and charging procedures.



Figure 1.34: MD #166455

### MD #166456

Battery acid hazard

#### WARNING

- Corrosive and poisonous battery acid. Acid can severely burn your body and clothing.



Figure 1.35: MD #166456

## SAFETY

### MD #166457

General hazard pertaining to machine operation and servicing

#### CAUTION

To avoid injury or death from improper or unsafe machine operation:

- Read the operator's manual and follow all safety instructions. If you do not have a manual, obtain one from your Dealer.
- Do not allow untrained persons to operate the machine.
- Review safety instructions with all Operators every year.
- Ensure that all safety signs are installed and legible.
- Make certain everyone is clear of machine before starting engine and during operation.
- Keep riders off the machine.
- Keep all shields in place and stay clear of moving parts.
- Disengage header drive, put transmission in Neutral and wait for all movement to stop before leaving operator's position.
- Stop the engine and remove the key from ignition before servicing, adjusting, lubricating, cleaning, or unplugging machine.
- Engage locks to prevent lowering of header or reel before servicing in the raised position.
- Use slow moving vehicle emblem and flashing warning lights when operating on roadways unless prohibited by law.

Run-over hazard

#### WARNING

- Machine will move if steering wheel is turned while engine is running.
- Steering response is opposite to what is normally expected when backing up. Turn bottom of steering wheel in direction you want to go.
- Always move ground speed lever to slow end of range before shifting high-low speed control.
- Stop the engine and remove the key from ignition before servicing, adjusting, lubricating, cleaning, or unplugging the machine.

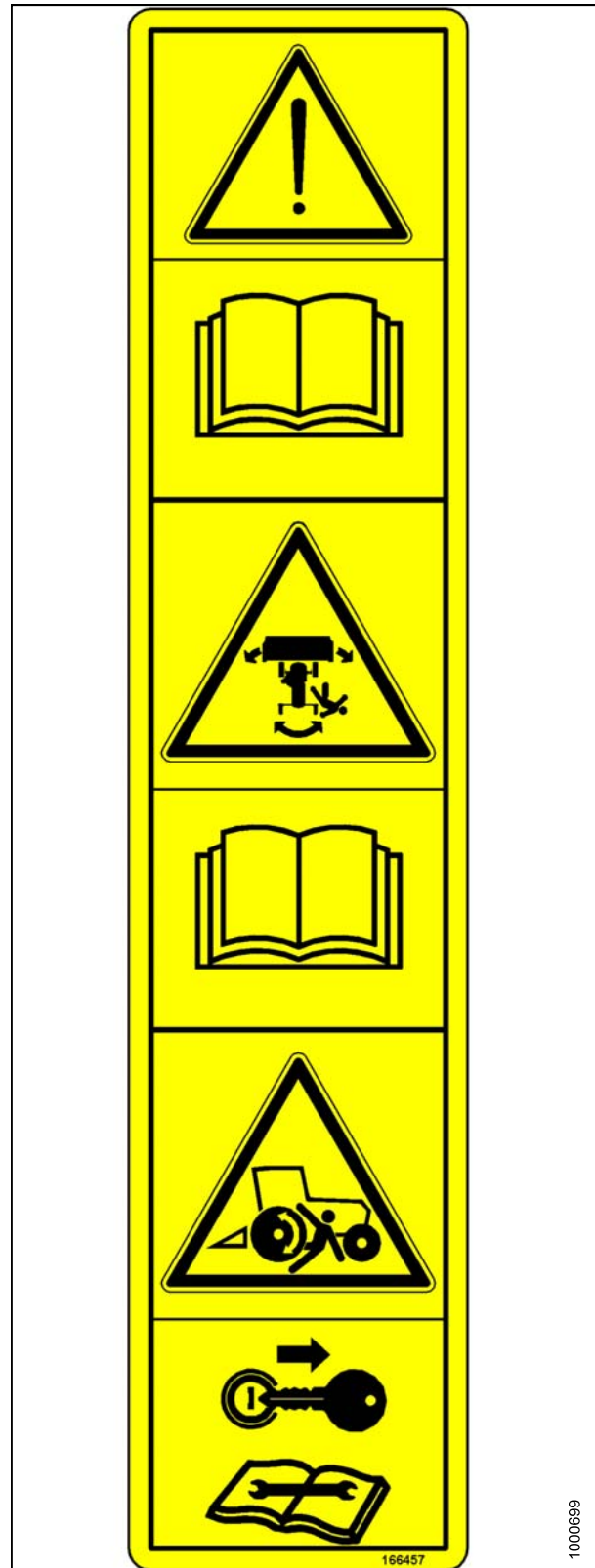

Figure 1.36: MD #166457

## SAFETY

### MD #166461

Hot fluid under pressure hazard

#### CAUTION

- Coolant is under pressure and may be hot. Never remove pressurized coolant tank cap when engine is hot.



Figure 1.37: MD #166461

### MD #166463

Collision hazard in transport

#### WARNING

- Collision between windrower and other vehicles may result in injury or death.

When driving windrower on public roadways:

- Obey all highway traffic regulations in your area. Use pilot vehicles front and rear of windrower if required by law.
- Use slow moving vehicle emblem and flashing warning lights unless prohibited by law.
- If width of attached header impedes other vehicle traffic, remove header and install MacDon approved weight box. Refer to operator's manual for safe procedure to tow header.



Figure 1.38: MD #166463

## SAFETY

### MD #166465

Loss of control hazard

#### WARNING

To avoid serious injury or death from loss of control:

- Do not make abrupt changes in steering direction.
- Anticipate turns by slowing down well in advance.
- Do not rapidly accelerate or decelerate while turning.
- Limit speed to maximum 20 mph (32 km/h) when towing a header. To ensure steering control, refer to operator's manual for adding weight to drive wheels.

When travelling on steep slopes:

- Reduce speed and lower header.
- Move ground speed lever to slow end of range.
- Shift high-low speed control to low range.

With header removed, steering control is reduced if weight is not added to drive wheels. If you must drive the windrower without header or MacDon weight system:

- Operate in low speed range.
- Avoid slopes.
- Do not tow a header. **If control of machine is lost, immediately pull ground speed lever to neutral.**

### MD #166466

High pressure oil hazard

#### WARNING

- Do not go near leaks.
- High pressure oil easily punctures skin causing serious injury, gangrene, or death.
- If injured, seek emergency medical help. Immediate surgery is required to remove oil.
- Do not use finger or skin to check for leaks.
- Lower load or relieve hydraulic pressure before loosening fittings.

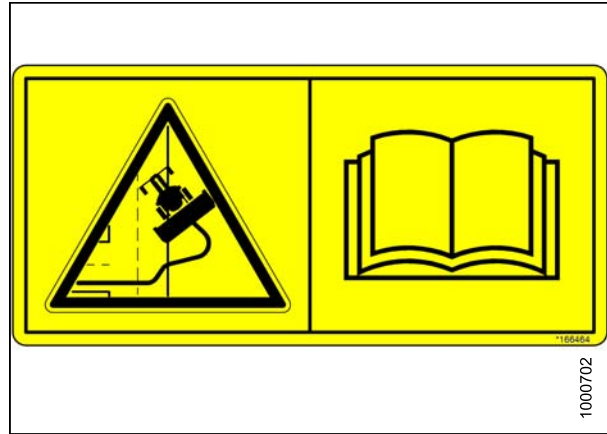

Figure 1.39: MD #166465



Figure 1.40: MD #166466

## SAFETY

### MD #166833

Run-over hazard

#### WARNING

- Remove key from ignition.
- Read tractor and mower manufacturer's manuals for inspection and maintenance instructions.
- Read the windrower and header manuals for inspection and maintenance instructions.

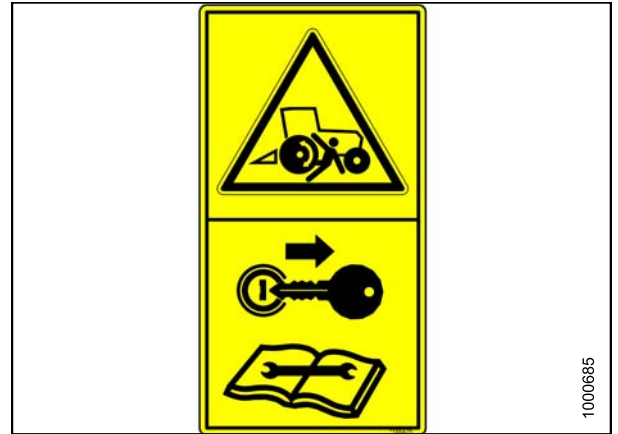

Figure 1.41: MD #166425

### MD #167502

Pinch point hazard

#### WARNING

- To avoid injury, be cautious when opening/closing the training seat to avoid getting pinched.
- Failure to comply could result in death or serious injury.



Figure 1.42: MD #167502

### MD #167504

Emergency exit

#### ATTENTION

- To exit the machine via the secondary door, follow the arrow on the running man sign.

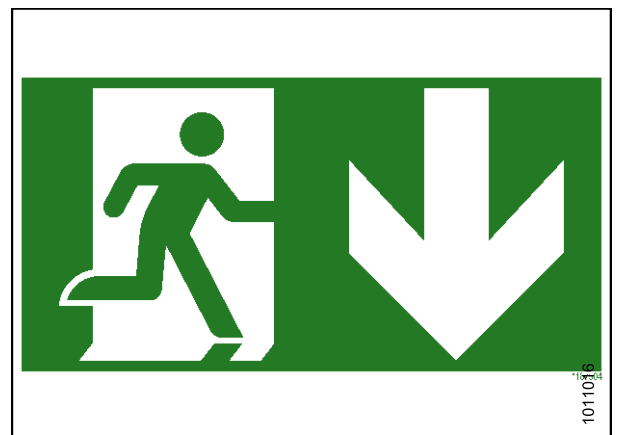

Figure 1.43: MD #167504

## SAFETY

### MD #184372

General hazard pertaining to machine operation and servicing

#### CAUTION

To avoid injury or death from improper or unsafe machine operation:

- Read the operator's manual and follow all safety instructions. If you do not have a manual, obtain one from your Dealer.
- Do not allow untrained persons to operate the machine.
- Review safety instructions with all Operators annually.
- Ensure that all safety signs are installed and legible.
- Make certain everyone is clear of machine before starting engine and during operation.
- Keep riders off the machine.
- Keep all shields in place and stay clear of moving parts.
- Disengage header drive, put transmission in Neutral, and wait for all movement to stop before leaving operator's position.
- Stop the engine and remove the key from ignition before servicing, adjusting, lubricating, cleaning, or unplugging machine.
- Engage safety props to prevent lowering of raised unit before servicing in the raised position.
- Use slow moving vehicle emblem and flashing warning lights when operating on roadways unless prohibited by law.

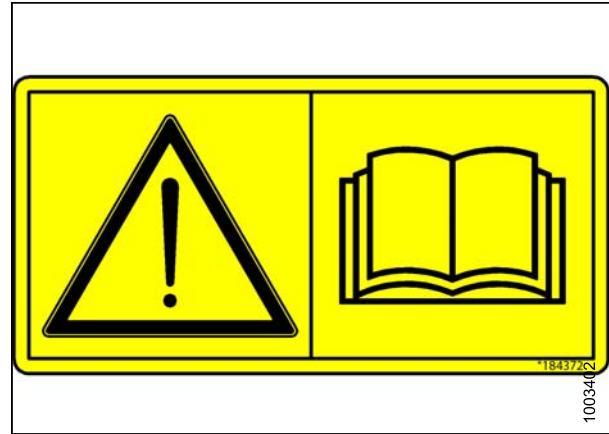

Figure 1.44: MD #184372

### MD #190546

Slippery surface

#### WARNING

- Do not use this area as a step or platform.
- Failure to comply could result in serious injury or death.



Figure 1.45: MD #190546

## 2 Product Overview

### 2.1 Definitions

The following terms and acronyms may be used in this manual.

Term	Definition
A-Series header	MacDon auger header
API	American Petroleum Institute
ASTM	American Society of Testing and Materials
Bolt	A headed and externally threaded fastener that is designed to be paired with a nut
Cab-forward	Windrower operation with the Operator and cab facing in the direction of travel
CDM	Cab display module on a self-propelled windrower
Center-link	A hydraulic cylinder link between the header and the machine to which it is attached: It is used to change header angle
CGVW	Combined vehicle gross weight
DEF	Diesel exhaust fluid; also called AdBlue in Europe, and AUS 32 in Australia
DEF supply module	Pumps diesel exhaust fluid through the system
DM	Dosing module
D-Series header	MacDon D50, D60, and D65 rigid draper headers
DK	Double knife
DKD	Double-knife drive
DDD	Double-draper drive
DOC	Diesel oxidation catalyst
DRT	Decomposition Reactor Tube
DWA	Double Windrow Attachment
ECM	Engine control module
ECU	Electronic control unit
Engine-forward	Windrower operation with the Operator and engine facing in the direction of travel
Finger tight	Finger tight is a reference position where sealing surfaces or components are making contact with each other and the fitting has been tightened to a point where the fitting is no longer loose
FFFT	Flats from finger tight
GSL	Ground speed lever
GSS	Grass Seed Special
GVW	Gross vehicle weight
Hard joint	A joint made with the use of a fastener where the joining materials are highly incompressible
Header	A machine that cuts and lays crop into a windrow and is attached to a self-propelled windrower

## PRODUCT OVERVIEW

<b>Term</b>	<b>Definition</b>
Hex key	A hex key or Allen key (also known by various other synonyms) is a tool of hexagonal cross-section used to drive bolts and screws that have a hexagonal socket in the head (internal-wrenching hexagon drive)
HDS	Hydraulic deck shift
hp	Horsepower
ISC	Intermediate Speed Control
JIC	Joint Industrial Council: A standards body that developed the standard sizing and shape for original 37° flared fitting
Knife	A cutting device which uses a reciprocating cutter (also called a sickle)
MDS	Mechanical deck shift
n/a	Not applicable
Nut	An internally threaded fastener that is designed to be paired with a bolt
N-DETENT	The slot opposite the NEUTRAL position on operator's console
NPT	National Pipe Thread: A style of fitting used for low pressure port openings Threads on NPT fittings are uniquely tapered for an interference fit
ORB	O-ring boss: A style of fitting commonly used in port opening on manifolds, pumps, and motors
ORFS	O-ring face seal: A style of fitting commonly used for connecting hoses and tubes This style of fitting is also commonly called ORS, which stands for O-ring seal
rpm	Revolutions per minute
R-Series header	MacDon rotary disc header
RoHS (Reduction of Hazardous Substances)	A directive by the European Union to restrict the use of certain hazardous substances (such as hexavalent chromium used in some yellow zinc platings)
SAE	Society of Automotive Engineers
SCR	Selective catalytic reduction
Screw	A headed and externally threaded fastener that threads into preformed threads or forms its own thread in one of the mating parts
SDD	Single-drapeer drive
Self-Propelled (SP) Windrower	Self-propelled machine consisting of a power unit with a header
SK	Single knife
SKD	Single-knife drive
Soft joint	A joint made with the use of a fastener where the joining materials are compressible or experience relaxation over a period of time
spm	Strokes per minute
Tension	Axial load placed on a bolt or screw, usually measured in pounds (lb) or Newtons (N)
TFFT	Turns from finger tight
Torque	The product of a force X lever arm length, usually measured in foot-pounds (ft·lbf) or Newton-meters (N·m)



## PRODUCT OVERVIEW

<b>Term</b>	<b>Definition</b>
Torque angle	A tightening procedure where the fitting is assembled to a precondition (finger tight) and then the nut is turned further a number of degrees or a number of flats to achieve its final position
Torque-tension	The relationship between the assembly torque applied to a piece of hardware and the axial load it induces in the bolt or screw
ULSD	Ultra low sulphur diesel
UCA	Upper cross auger
Washer	A thin cylinder with a hole or slot located in the center that is to be used as a spacer, load distribution element, or a locking mechanism
Windrower	Power unit of a self-propelled header
WCM	Windrower control module

## PRODUCT OVERVIEW

### 2.2 Specifications

<b>Engine</b>		
Type	Cummins QSB-4.5L CM2350 4 cylinder turbo diesel, B20 biodiesel approved	
Displacement	275 cu. in. (4.5 L)	
Power	Rated	156 hp (116 kW) @ 2200 rpm
<b>Electrical System</b>		
Recommended battery (2)	12 Volt, maximum dimension: 13.25 x 7.37 x 9.44 in. (334 x 188 x 232 mm), group rating 29H or 31A. Heavy duty / off road / vibration resistant.	
Minimum CCA per battery (cold cranking amps)	650	
Battery BCI group rating	29H or 31A	
Alternator	160 amp	
Egress lighting	Standard	
Warning beacons	Standard	
Starter	Wet type	
Working lights	11	
GPS ready	Wiring harness factory installed for Trimble® and JD Greenstar	
<b>Traction Drive</b>		
Type	Hydrostatic, three-speed electric shift	
Speed	Field (cab-forward)	Low range: 0–11 mph (18 km/h), Mid range: 0–16 mph (26 km/h)
	Reverse (cab-forward)	6 mph (9.6 km/h)
	Transport (engine-forward)	High range: 0–23 mph (37 km/h)
Transmission	Type	2 piston pumps: 1 per drive wheel
	Displacement	2.65 cu. in. (44 cc)
	Flow	40 US gpm (167 L/min)
	Pressure	5500 psi (379 bar)
Final drive	Type	Planetary gearbox
	Ratio	30.5 : 1
Wheel motor displacement	Low range	4.15 cu. in. (68 cc)
	Mid range	3.01 cu. in. (50 cc)
	High range	1.93 cu. in. (32 cc)

## PRODUCT OVERVIEW

<b>System Capacities</b>		
Fuel tank		97 US gallons (367 L)
Hydraulic reservoir		17.2 US gallons (65 L)
Diesel exhaust fluid (DEF) tank capacity		7.5 US gallons (29 L)
<b>Header Drive</b> (refer to Table <a href="#">2.1 Hydraulic Pumps, page 33</a> ).		
<b>Header Lift/Tilt</b>		
	Type	Hydraulic double acting cylinders Tilt - optional hydraulic positioning Hydraulic center-link
	Function	Lift/tilt/float
<b>Header Float</b>		
	Primary adjustment	Manual, external, drawbolt with springs (1 per side), two inner booster spring
	Fine adjustment	Hydraulic, in-cab switch
	Automatic	Hydraulic, three programmable settings for all headers (Deck shift compensation on draper headers)
<b>Cab</b>		
Type		Spring/shock suspension
Dimensions	Width	63 in. (1600 mm)
	Depth	68.3 in. (1735 mm) (at top of window)
	Height	64.6 in. (1640 mm)
	Volume	125 cu. ft. (3540 L)
Seat	Driver	Adjustable air-ride suspension, seat belt
	Training	Folding, cab mounted, seat belt
Windshield wiper	Front	31.5 in. (800 mm) Blade
	Rear	22 in. (560 mm) Blade
Heater		37,900 Btu/h (11,107 W)
Air conditioning		29,800 Btu/h (8734 W)
Electrical outlets		One live, two on ignition, one live/keyed
Mirrors		One inside (transport), two outside (field)
Radio		Two speakers and antenna are factory installed. Radio is dealer installed
<b>System Monitoring</b>		
Speeds		Ground (mph or km/h), engine (rpm), knife (spm), disc (rpm), reel (rpm or mph/km/h), conveyor (ref. no.)
Header		Height, angle, float, header drive load gauge
<b>Tire Options</b> (Refer to <a href="#">2.3 Drive Tires, page 34</a> for options.)		
<b>Frame and Structure</b>		
Dimensions		Refer to <a href="#">2.3 Drive Tires, page 34</a>

## PRODUCT OVERVIEW

Frame to ground (crop clearance)		45.7 in. (1160 mm)
Weight	Base	9810 lbs (4450 kg) <sup>1</sup>
	Maximum GVW	21,500 lbs (9750 kg) <sup>1</sup>
	Maximum CGVW	23,100 lbs (10,480 kg) <sup>1</sup>
<b>Header Compatibility</b>		
Auger headers	A30-D, A40-D	All sizes
Draper headers	D50 <sup>2</sup>	Up to 35 ft.
	D60 and D65 <sup>2</sup>	Up to 40 ft.
Rotary disc	R80 and R85	13 ft. only <sup>3</sup>

**NOTE:**

Specifications and design are subject to change without notice or obligation to revise previously sold units.

**Pump Locations:**

- A – Piston pump (closest to engine) knife drive.
- B – Reel/conveyor pump (or M2 with disc).
- C – The inner gear pump normally is routed directly to the cooler bypass valve and combines with the return flow from the first gear pump. From there the oil is cooled and heads through the high pressure filter and then into the supercharge valve block (item G:6) If a Double Window Attachment (DWA) is installed, this flow is diverted to first power the draper and the return flow then proceeds to the supercharge valve block as above.
- D – The outboard gear pump (D) supplies oil to the multifunction control block and the returned oil combines with the inboard gear pump (C) return flow at the cooler bypass and maintains a stand by pressure to operate brake disengage, either low or high speed range, and neutral interlock cylinder.
- E – Traction drive double piston pump. Engine end pump drives right-hand wheel outboard pump drives left-hand wheel.

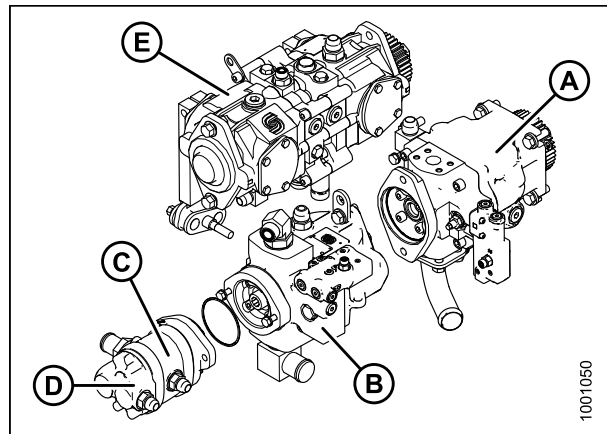

**Figure 2.1: Pumps**

1. Weights do not include options.  
 2. Depending on header options.  
 3. Only 18.4 x 26 tires are compatible with the 13 ft. R80 and R85.

## PRODUCT OVERVIEW

**Table 2.1 Hydraulic Pumps**

Pump Type	Specifications	Controller Type	Function
Pump A - Load sense pressure compensated piston pump	Variable displacement: 0–2.75 cu. in. (45 cc) flow = 0–27 gpm (102 L/min) at 4000 psi (27.56 MPa)	Electric over hydraulic max. flow rate determined by header ID	Knife drive or part of disc drive (option) M1 circuit
Pump B - Load sense pressure compensated piston pump	Variable displacement: 0–2.32 cu. in. (38 cc) flow = 0–24 gpm (84 L/min) at 3200 psi (22.05 MPa)	Electric over hydraulic max. flow rate determined by header ID	Conveyor and reel drive or part of disc drive (option) M2 circuit
Pump C - Gear pump	Displacement: 1.02 cu. in. (16.7 cc) Flow at Full Throttle 11.5 gpm. (44 L/min) at 2500 psi (17.23 MPa)	Engine rpm	Supercharge flow and pressure for traction drive, brake release, neutral lock, and DWA draper drive (if installed)
Pump D - Gear pump	Displacement: 1.02 cu. in. (16.7 cc) flow at full throttle 11.5 gpm. (44 L/min) at 2500 psi (17.23 MPa)	Engine rpm	Supercharge flow and pressure for traction drive, brake release, and neutral lock

## 2.3 Windrower Dimensions

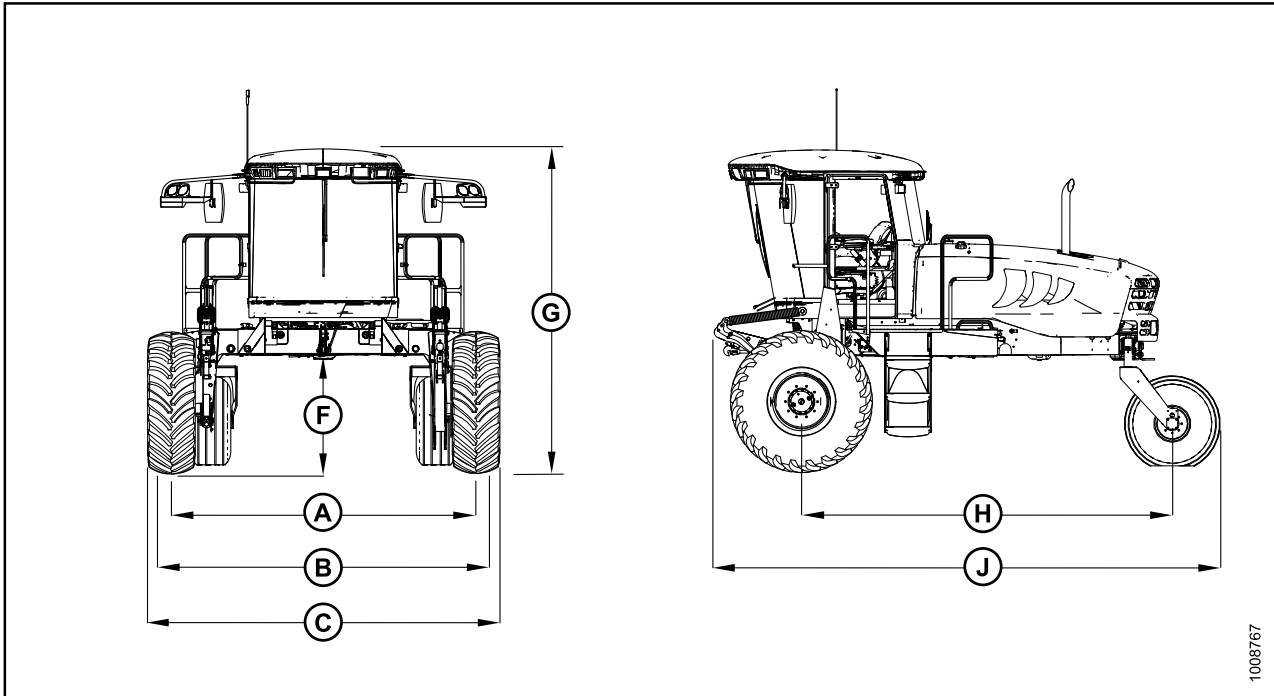

**Figure 2.2: Windrower Dimensions – Cab-Forward**

A - Drive Tire Tread  
 F - 45-3/4 in. (1160 mm)  
 J - 207-7/8 in. (5280 mm)

B - Drive Tire Hubs  
 G - 133 in. (3378 mm)

C - Drive Tires  
 H - 158-5/16 in. (4022 mm)

**Table 2.2 Drive Tires**

Tire Size	Wheel Position	Tread (A) in. (mm)	Hubs (B) in. (mm)	Tires (C) in. (mm)
18.4 x 26 bar & turf narrow track <sup>4</sup>	Inner/outer (shipping)	123-3/4 (3144)	140-9/16 (3571)	143-7/16 (3644)
	Outer/outer	130-7/8 (3324)	147-11/16 (3751)	150-5/8 (3824)
	Inner/inner	116-11/16 (2964)	133-1/2 (3391)	136-3/8 (3464)
18.4 x 26 bar and turf wide track <sup>4</sup>	Inner/outer (shipping)	130-11/16 (3319)	140-9/16 (3571)	150-3/8 (3819)
	Outer/outer	137-3/4 (3499)	147-11/16 (3751)	157-7/16 (3999)
	Inner/inner	123-9/16 (3139)	133-1/2 (3391)	143-1/4 (3639)
600/65R28 radial tire	Inner/outer (shipping)	123-9/16 (3139)	140-9/16 (3571)	147-15/16 (3758)
	Outer/outer	130-11/16 (3319)	147-11/16 (3751)	155-1/16 (3938)
	Inner/inner	116-1/2 (2959)	133-1/2 (3391)	140-7/8 (3578)

4. Only 18.4 x 26 tires are compatible with the 13-foot R80 and R85.

## PRODUCT OVERVIEW

Tire Size	Wheel Position	Tread (A) in. (mm)	Hubs (B) in. (mm)	Tires (C) in. (mm)
23.1-26 turf tires	Inner/outer (shipping)	126-1/8 (3203)	140-9/16 (3571)	149-5/16 (3793)
	Outer/outer	133-3/16 (3383)	147-11/16 (3751)	156-7/16 (3973)
	Inner/inner	119 (3023)	133-1/2 (3391)	142-1/4 (3613)

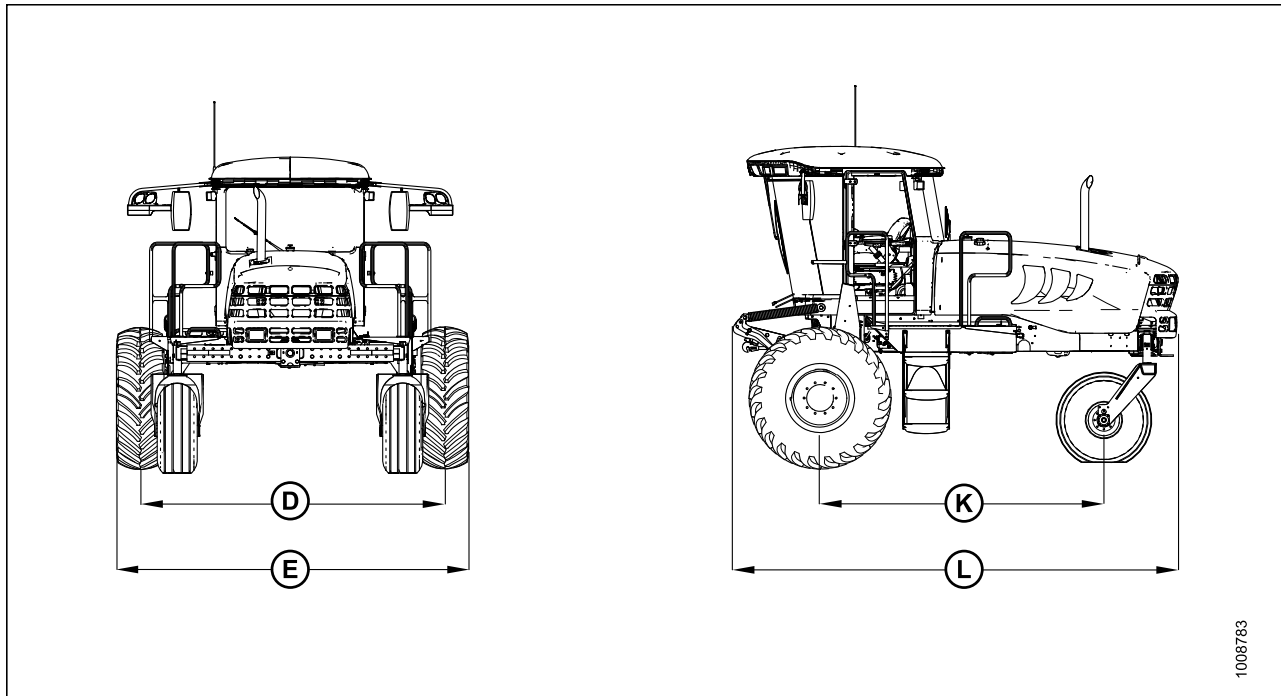

**Figure 2.3: Windrower Dimensions – Engine Forward**

D - Caster Tire Tread

E - Caster Tire Casters

K - 120-9/16 in. (3064 mm)

L - 186-7/8 in. (4747 mm)

**Table 2.3 Caster Tires**

Tire Size	Wheel Position	Tread (D) in. (mm)	Castors (E) in. (mm)
7.5-16SL	Minimum	96-7/16 (2448)	118-15/16 (3032)
	Maximum	135-11/16 (3448)	158-3/4 (4032)
10-16 formed caster	Minimum	96-7/16 (2448)	118-15/16 (3032)
	Maximum	135-11/16 (3448)	158-3/4 (4032)
10-16 forked caster	Minimum	96-7/16 (2448)	118-11/16 (3014)
	Maximum	135-11/16 (3448)	158 (4014)
16.5 x 16.1	Minimum	96-7/16 (2448)	118-11/16 (3014)
	Maximum	135-11/16 (3448)	158 (4014)

## 2.4 Component Location

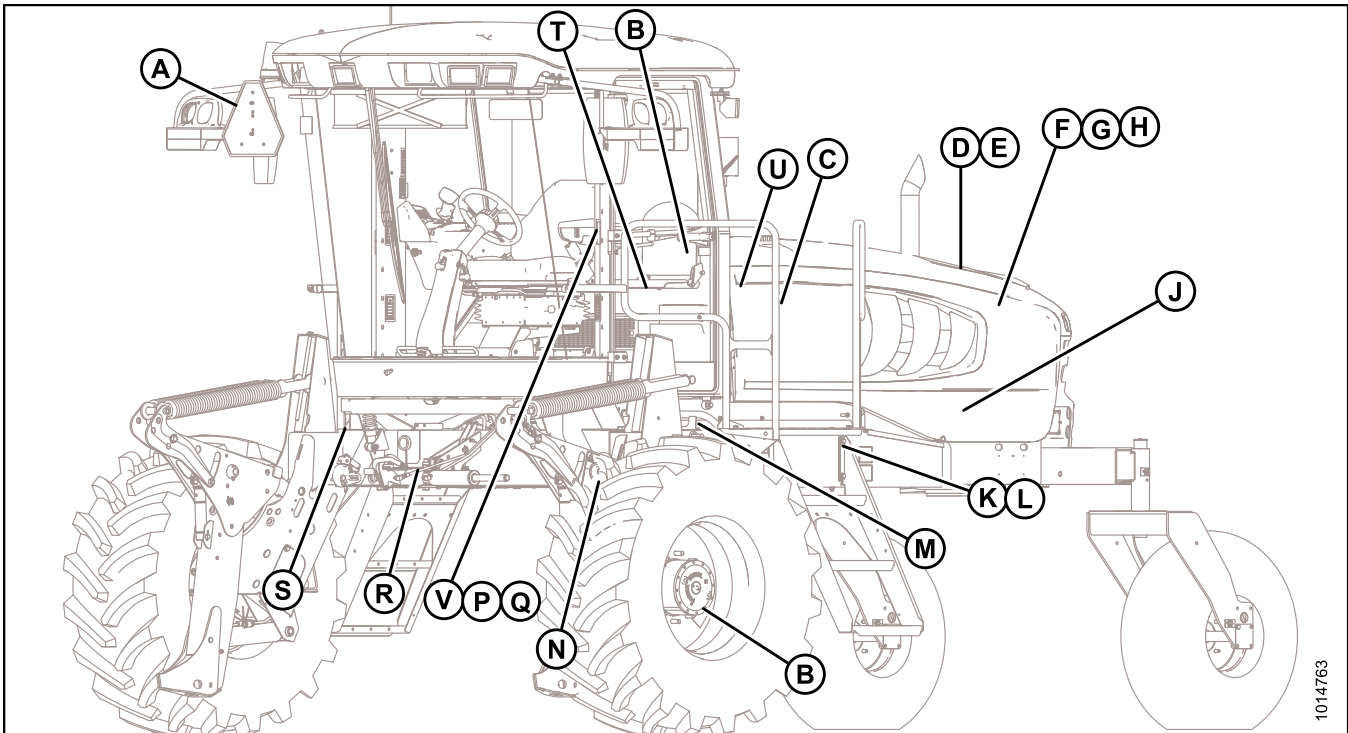

1014763

**Figure 2.4: Front Cab-Forward View**

A - Header Lift Leg  
 D - Windshield Wiper  
 G - Field/Road Lights  
 K - Mirror  
 N - Center-Link

B - Header Float Springs  
 E - Turn Signal/Hazard Lights  
 H - Handholds  
 L - Door

C - Operator's Station  
 F - Tail Light Engine-Forward  
 J - Tail Light Engine-Forward  
 M - Maintenance Platform



## PRODUCT OVERVIEW

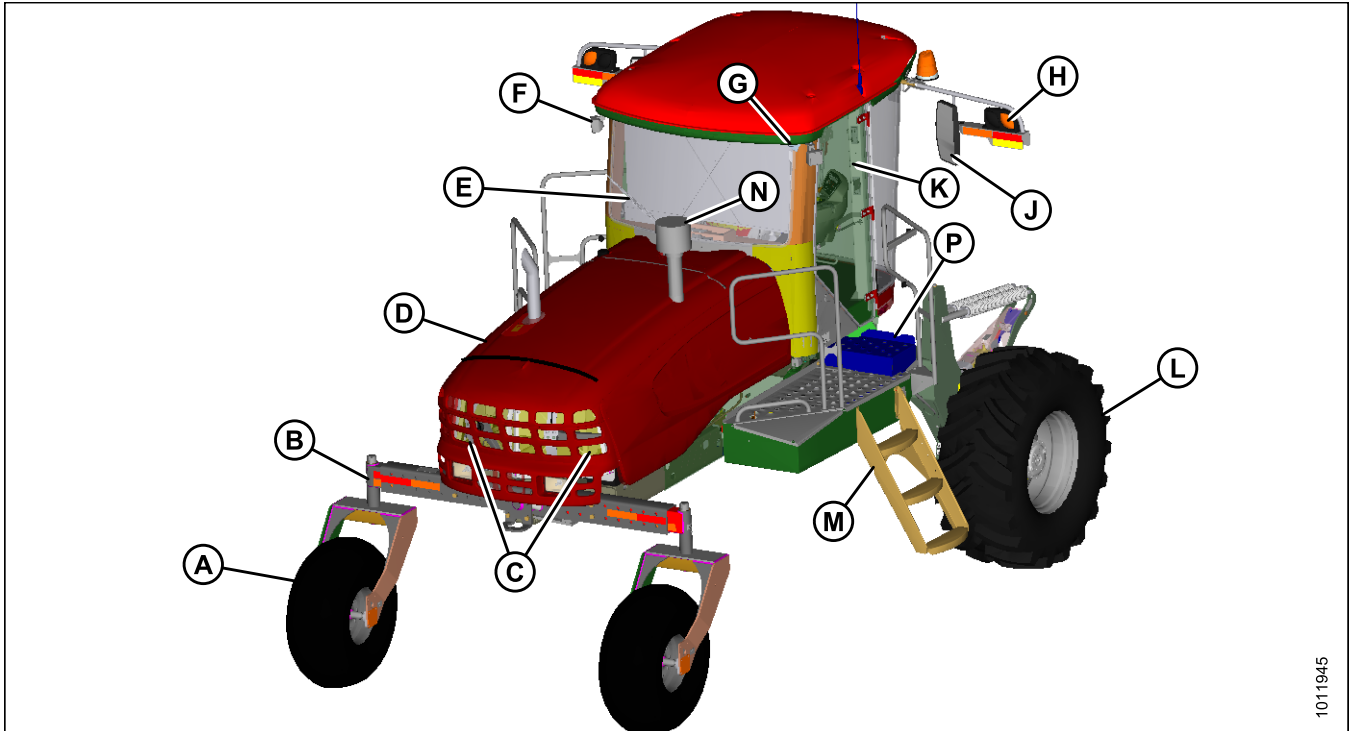

1011945

**Figure 2.5: Rear Cab-Forward View**

A - Caster Wheel  
D - Engine Compartment Hood  
G - Horn  
K - Door  
N - Pre-cleaner

B - Walking Beam  
E - Windshield Wiper  
H - Turn Signal/Hazard Lights  
L - Drive Wheel  
P - Diesel Exhaust Fluid (DEF) Tank

C - Tail Lights - Cab-Forward (Option)  
F - Field/Road Lights  
J - Mirror  
M - Maintenance Platform



### 3 Operator's Station

The operator's station is designed for operating the windrower in cab-forward mode (working mode) or in engine-forward mode (transport mode). The operator's station, which includes the seat, console, and steering column, pivots 180° so that the Operator maintains access to the windrower controls and gauges regardless of the direction of travel.

#### 3.1 Operator Console

The console contains controls to operate the windrower, as well as amenities for the Operator. The console position is adjustable to suit each particular Operator.

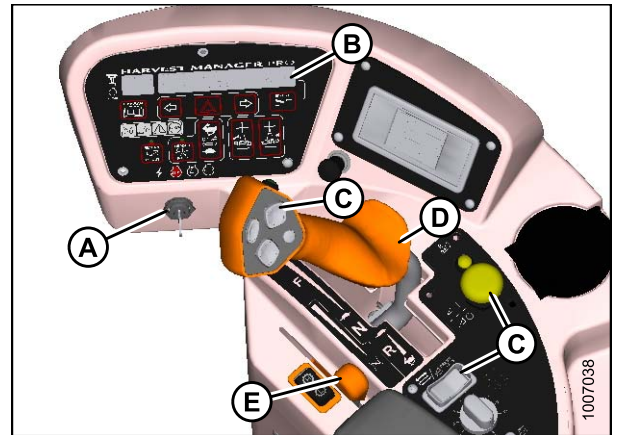

**Figure 3.1: Operator Console**

- |                     |                              |
|---------------------|------------------------------|
| A - Ignition        | B - Cab Display Module (CDM) |
| C - Header Controls | D - Ground Speed Lever (GSL) |
| E - Throttle        |                              |

1. Adjusting fore-aft and height:
  - a. Pull lever (A) and slide console fore or aft to the desired position.
  - b. Release lever to lock console.

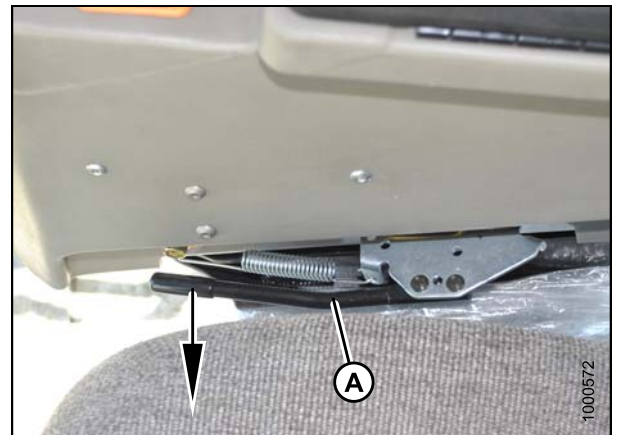

**Figure 3.2: Console Fore-Aft**

## OPERATOR'S STATION

2. Adjusting only fore-aft:
  - a. Loosen nuts (A) under console.
  - b. Move console as required.
  - c. Tighten nuts (A).

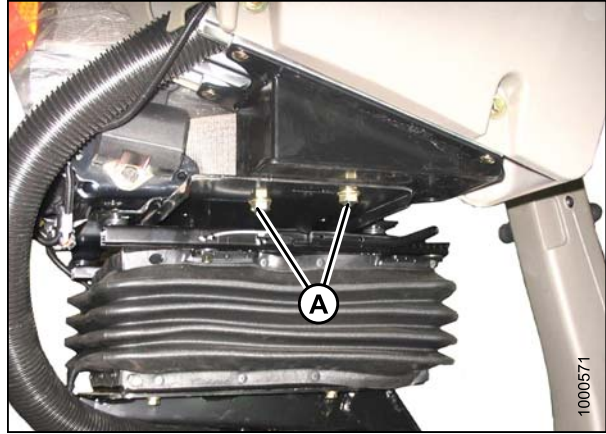

**Figure 3.3: Console Fore-Aft**

## 3.2 Operator Presence System

The operator presence system is a safety feature designed to deactivate or alert selected systems when the Operator is not seated at the operator's station.

These systems include:

- Header drive
- Engine and transmission

### 3.2.1 Header Drive

- To engage the header drive, the Operator must be seated in the operator's seat.
- If the Operator leaves the seat, power to the header drive is maintained for five seconds, then the header shuts down automatically.
- To restart the header after an automatic shut down, move the HEADER DRIVE switch to the OFF position and then to the ON position.

### 3.2.2 Engine and Transmission

- If the HEADER DRIVE switch is engaged, the engine will not start.
- If the windrower is moving 5 mph (8 km/h) or slower and the Operator leaves the seat, the CDM will flash NO OPERATOR on the upper line and ENGINE SHUT DOWN 5...4...3...2...1...0 on the lower line accompanied by a steady tone. When the countdown reaches 0, the engine shuts down.
- If the windrower is moving 5 mph (8 km/h) or faster, and the Operator leaves the seat for more than five seconds, an alarm will sound and the lower display line will flash NO OPERATOR.
- If the Operator's seat is in between cab-forward and engine-forward positions and the transmission is not locked in the NEUTRAL position, the engine shuts off. The lower display will flash LOCK SEAT BASE until the seat base is locked into position.

## 3.3 Operator's Seat Adjustments

The operator's seat has several adjustments. Refer to the following for the location and description of each adjustment.

### 3.3.1 Fore-Aft

Adjusts fore-aft position.

1. Pull lever (A) up to release.
2. Move seat forward or rearward.
3. Release lever (A).

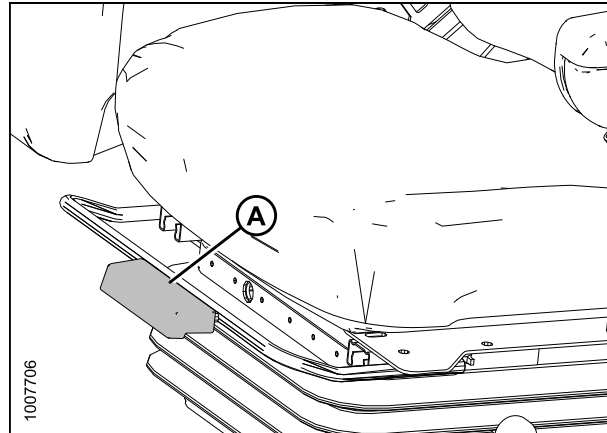

Figure 3.4: Fore-Aft Position

### 3.3.2 Seat Suspension and Height

Controls suspension stiffness and seat height.

INCREASE: Press upper switch (A).

DECREASE: Press lower switch (B).

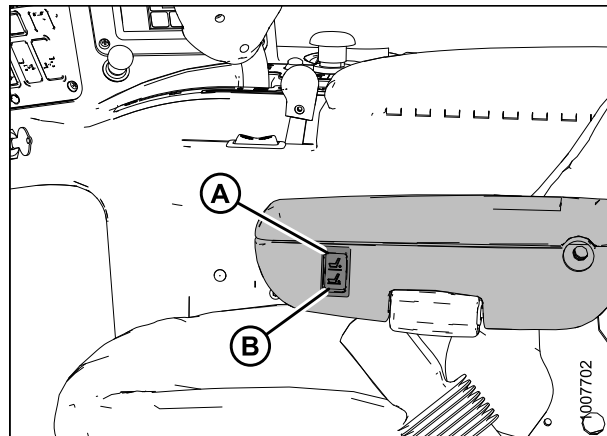

Figure 3.5: Seat Suspension and Height on Armrest

### 3.3.3 Vertical Dampener

Adjusts suspension dampening.

INCREASE: Turn knob (A) counterclockwise.

DECREASE: Turn knob (A) clockwise.

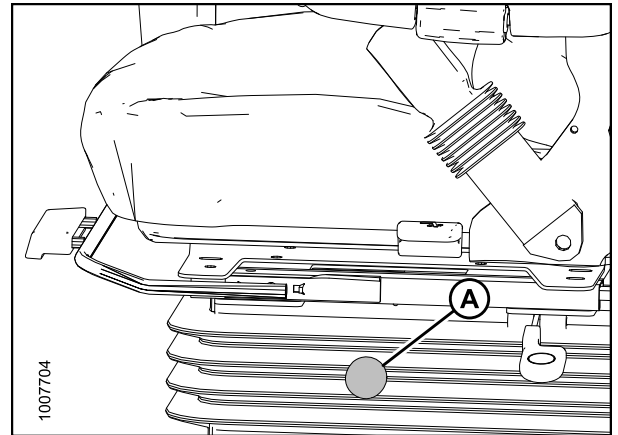

Figure 3.6: Vertical Dampener

### 3.3.4 Armrest

Raise armrest (A) for easier access to seat.

Lower armrest (A) after seat belt is buckled.

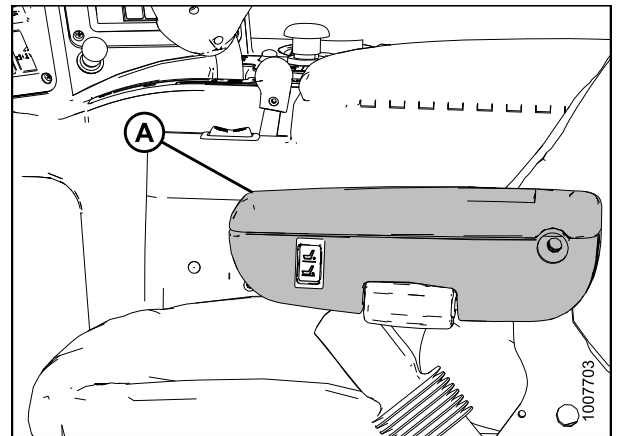

Figure 3.7: Armrest

### 3.3.5 Fore-Aft Isolator Lock

Locks seat fore-aft isolator.

LOCK: Push lever (A) down.

UNLOCK: Pull lever (A) up.

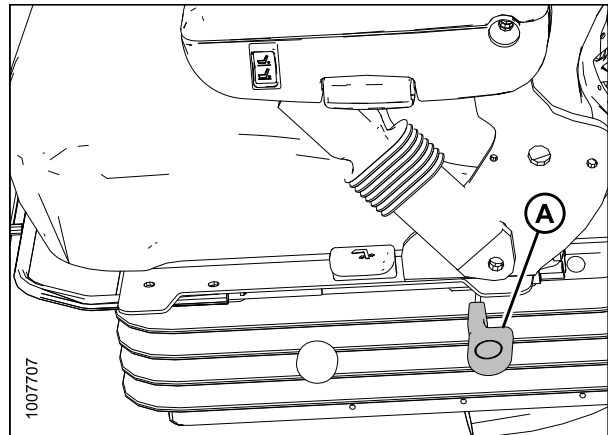

Figure 3.8: Fore-Aft Isolator Lock

### 3.3.6 Seat Tilt

To adjust seat tilt:

1. Pull lever (A) up to release.
2. Position seat back as desired.
3. Release lever (A).

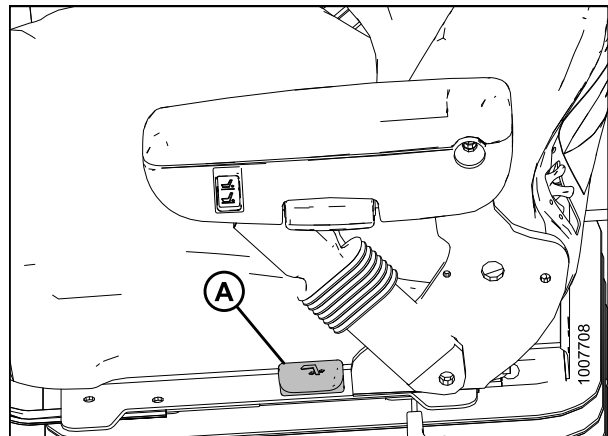

Figure 3.9: Seat Tilt



### 3.3.7 Armrest Angle

Adjusts angle of armrest.

INCREASE: Rotate knob (A) clockwise.

DECREASE: Rotate knob (A) counterclockwise.

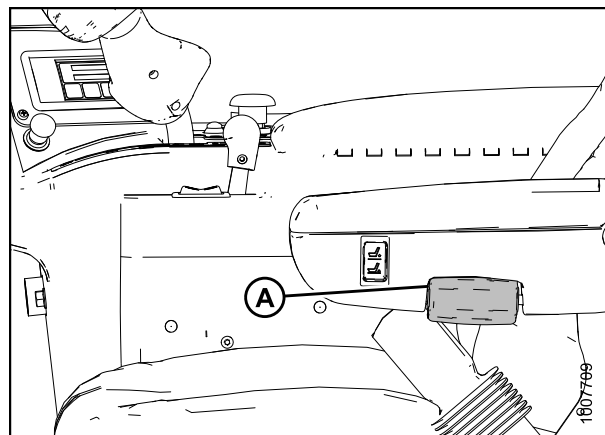

Figure 3.10: Armrest Angle

### 3.3.8 Lumbar Support

Adjusts stiffness of seat back.

INCREASE: Rotate knob (A) upward.

DECREASE: Rotate knob (A) downward.

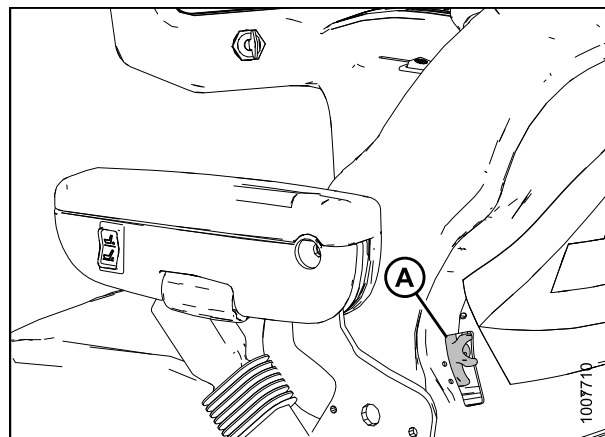

Figure 3.11: Lumbar Support

### 3.4 Training Seat

A wall-mounted fold-up training seat complete with seat belt is provided.

#### WARNING

- The training seat is provided for an experienced Operator of the machine when a new Operator is being trained.
- The training seat is NOT intended as a passenger seat or for use by children. Use the seat belt whenever operating the machine or riding as a Trainer.
- Keep all other riders off the machine.

For storage, lift seat (B) and secure with latch (A).

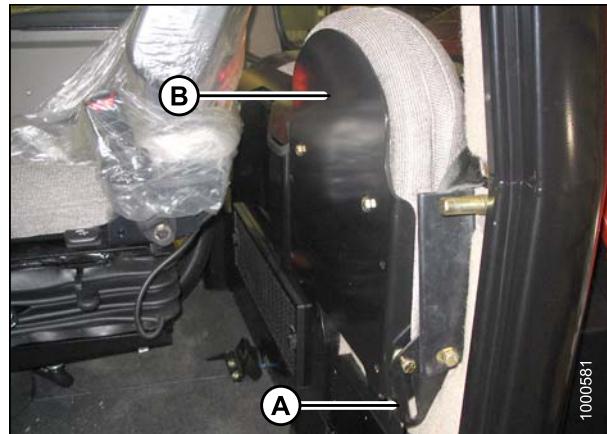

Figure 3.12: Training Seat

To lower seat, lift latch (A) and lower seat (B).



Figure 3.13: Training Seat

## 3.5 Seat Belts

The windrower is equipped with seat belts on the operator's and trainer's seats.

### WARNING

The seat belts can help ensure your safety if it is used and maintained.

- Before starting the engine, securely fasten your seat belt. Ensure that anyone occupying the trainee's seat is secured by a seat belt as well.
- Never wear a seat belt loosely or with slack in the belt system. Never wear the belt in a twisted condition or pinched between the seat structural members.

#### To fasten seat belt:

1. Pull belt with metal eye (A) at right side completely across your body.
2. Push the metal eye (A) into the buckle (B) until it locks.
3. Adjust the position of the belt as low on your body as possible.

#### To release seat belt:

4. Push the red button (C) in the end of the buckle.
5. Separate the buckle (B) and metal eye (A).

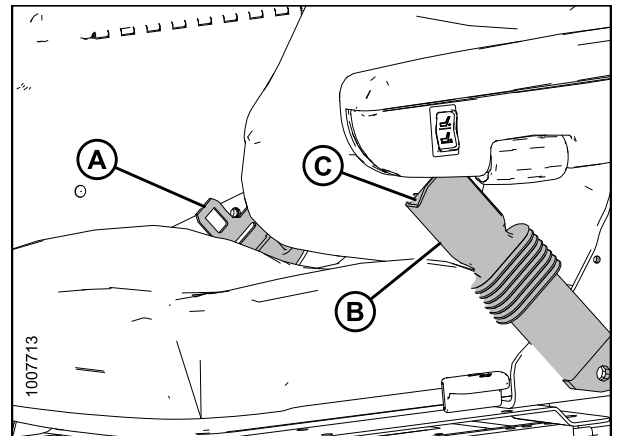

Figure 3.14: Seat Belt

### 3.6 Steering Column Adjustment

The steering column can be adjusted to suit each particular Operator and to make it easier to get in and out of the seat.

To adjust the steering column:

1. Hold onto steering wheel, lift handle (A), and move steering wheel up or down to desired position.
2. Release handle (A) to lock steering wheel position.

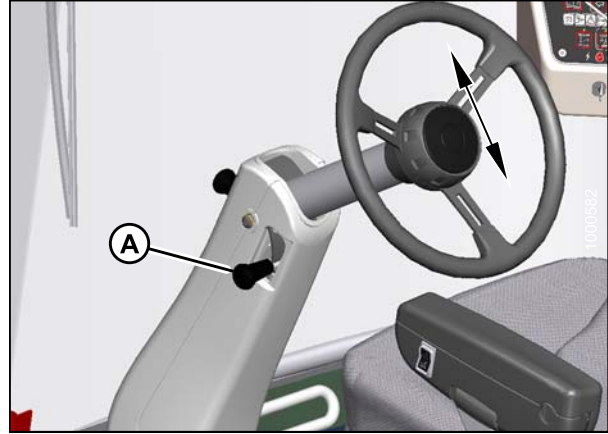

**Figure 3.15: Steering Column**

### 3.7 Lighting

The field, road, and beacon light switches are located on a panel in the cab headliner. The hazard light switch is located on the cab display module (CDM).

The position of the operator's station (cab-forward mode or engine-forward mode) automatically determines the lighting.

An auto-road light feature is available and is activated when certain conditions are met. For more information, refer to [3.7.6 Auto Road Light, page 53](#).

**IMPORTANT:**

Red and amber reflector tape is positioned so as to be visible in both engine-forward and cab-forward modes.

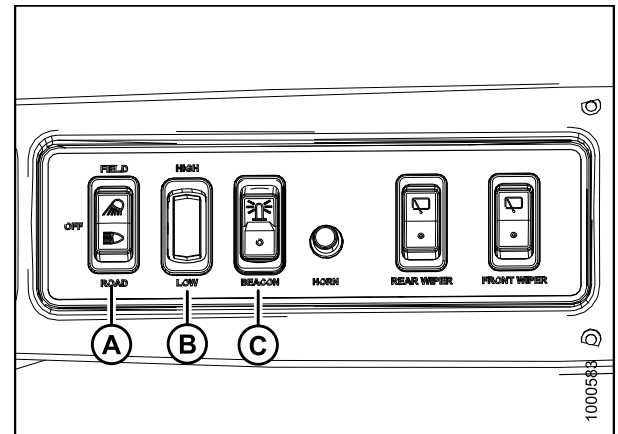

**Figure 3.16: Roof Liner Console**

A - Field or Road Lights      B - Low or High Beams  
C - Beacon

#### 3.7.1 Field Light: Cab-Forward

The following lights are ON when the light switch is in FIELD position with the windrower in cab-forward mode:

- Field lights in cab roof (front and rear)
- Swath lights in hood
- HID lights (if installed) on mirror supports

**NOTE:**

The field lights will not turn on if the auto-road light feature is activated (i.e., windrower is in engine- or cab-forward mode, out of park, high range switch position, and header off).

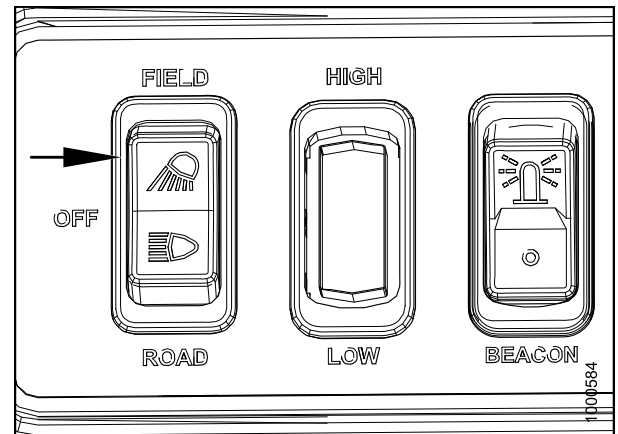

**Figure 3.17: Field Light Switch**

The two innermost lights in the field light group (A) at the front of the cab are adjustable. Refer to [Adjusting Field Lights, page 366](#).

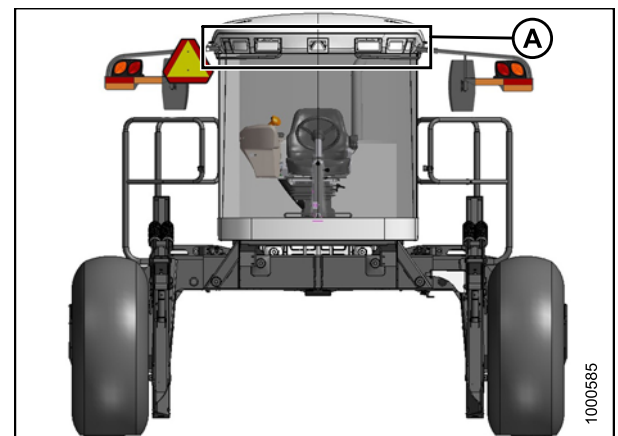

**Figure 3.18: Cab-Forward: Front View**

## OPERATOR'S STATION

The two field lights (A) at the rear of the cab are adjustable. Refer to [Adjusting Rear Flood Lights](#), page 372.

### NOTE:

When the engine is shut down, rear field lights (A) turn on for 60 seconds to illuminate the platform and stairs.

The two swath lights (B) in the hood are adjustable, but because they are used as road lights in engine-forward mode and adjusted accordingly, they should **NOT** be adjusted for field operation.

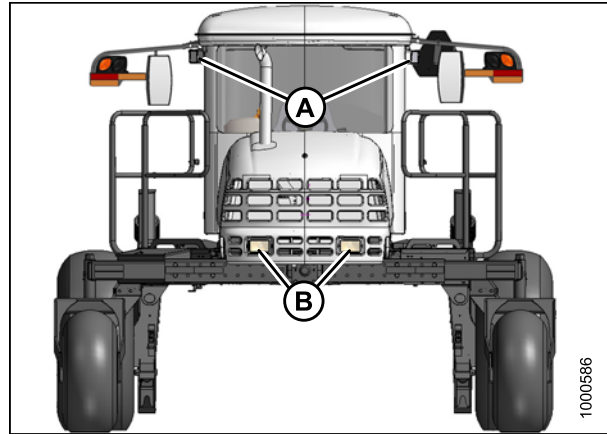

Figure 3.19: Cab-Forward: Rear View

### 3.7.2 Road Light: Engine-Forward

The following lights are ON when the light switch (A) is in ROAD position with the windrower in engine-forward mode:

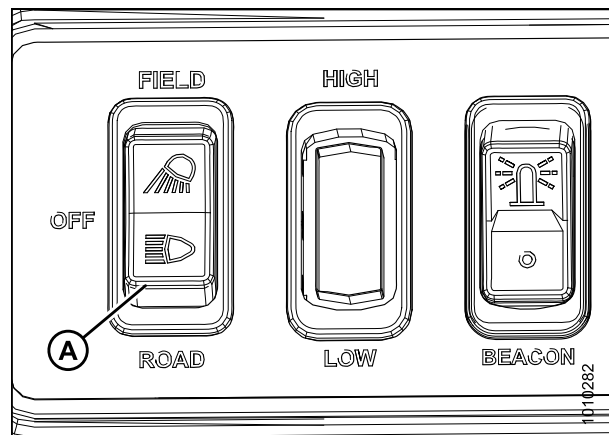

Figure 3.20: Road Light Switch

- Red tail lights (A) on the mirror supports
- Amber turn signals and hazard lights (B) on mirror supports rear view
- Beacon lights (C) on mirror supports

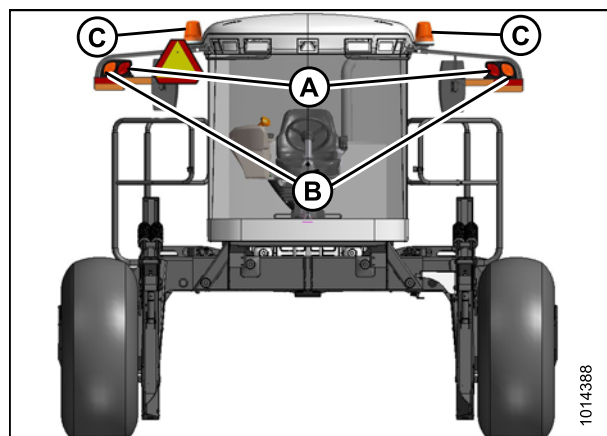

Figure 3.21: Engine-Forward: Rear View

## OPERATOR'S STATION

- Amber turn signals and hazard lights (A) on mirror supports front view
- Headlights (B) in hood with low/high
- Beacon lights (C) on mirror supports

The two headlights in the hood are adjustable. Refer to [Aligning Headlights, page 362](#).

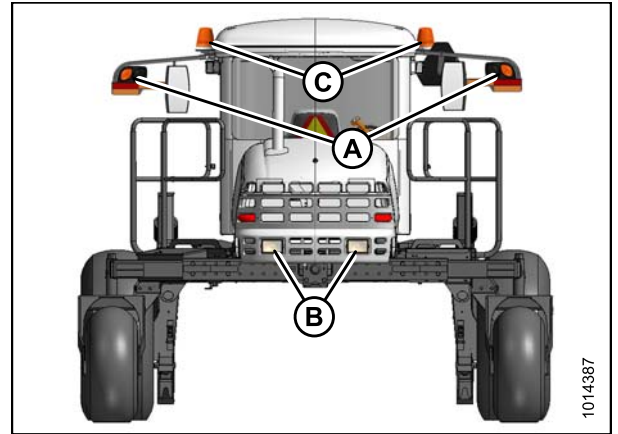

Figure 3.22: Engine-Forward: Front View

### 3.7.3 Road Light: Cab-Forward

If equipped, the following lights are functional with switch (A) in the ROAD position:

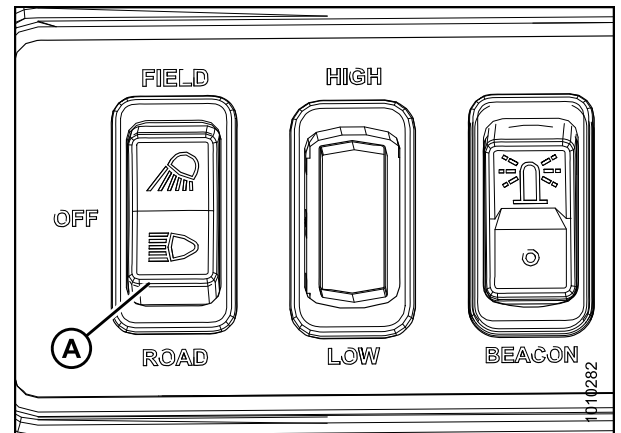

Figure 3.23: Road Light Switch

- Four lights (A) in cab roof
- Amber turn signals and hazard lights (B) on mirror supports visible from both front and rear
- Beacon lights (C) on both sides of the cab roof.

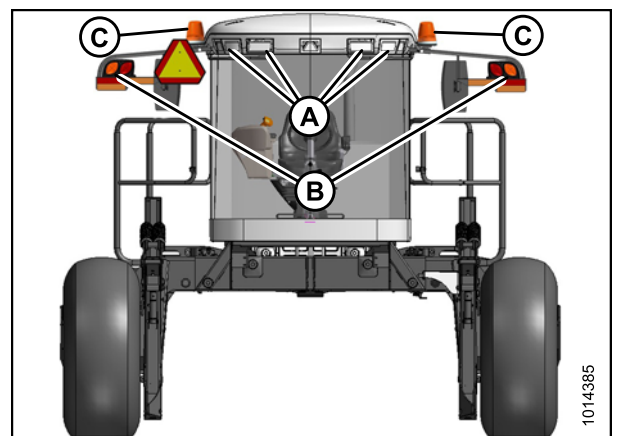

Figure 3.24: Cab Forward: Front View

## OPERATOR'S STATION

- Red lights (A) in hood
- Beacon lights (B) on mirror supports visible from both front and rear

### IMPORTANT:

Optional red tail lighting and marking kit must be installed so that road travel in the cab-forward mode complies with regulations. Refer to [6.3.2 Lighting and Marking for Cab-Forward Road Travel, page 423](#) or see your MacDon Dealer.

### NOTE:

If the red tail lighting kit is not installed, travelling in cab-forward mode and activating the turn indicator will trigger a stop lamp error.

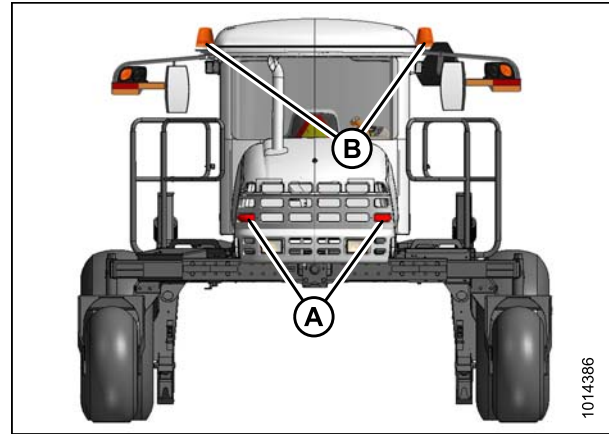

Figure 3.25: Cab Forward: Rear View

### 3.7.4 Hazard Light

The hazard lights can be switched on and off manually anytime by pressing the HAZARD switch (A) on the cab display module (CDM).

These lights will also turn on automatically when the auto-road light feature is activated (i.e., engine running, header off, and transmission in either mid or high range) and can only be turned off by engaging the header drive.

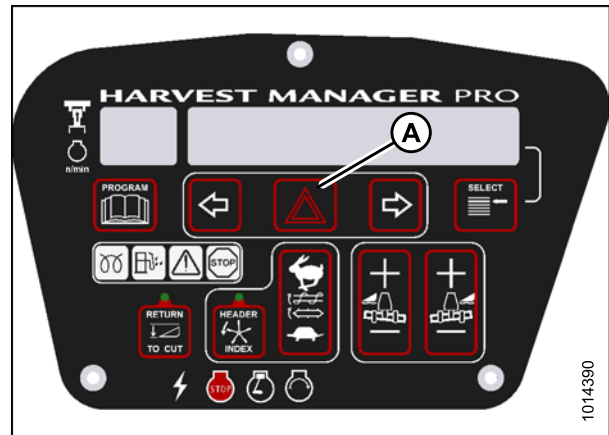

Figure 3.26: CDM



### 3.7.5 Beacon Light

The beacon lights (A) are functional when the ignition and the beacon switch (B) are ON.

The beacons will also turn on automatically when the auto-road light feature is activated (i.e., engine running, header off, and transmission in either mid or high range) and can only be turned off by engaging the header drive.

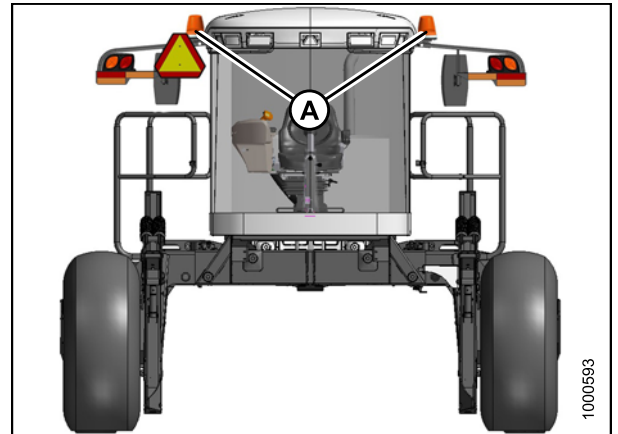

Figure 3.27: Cab-Forward: Front View

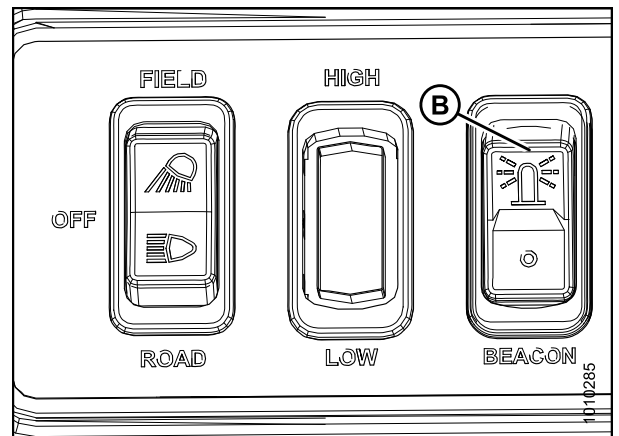

Figure 3.28: Beacon Light Switch

### 3.7.6 Auto Road Light

The beacon and hazard lights are included in the auto road light feature. The beacon and hazard lights will turn on when this feature is activated, and can only be turned off by engaging the header drive.

This feature will activate when:

- Windrower is in cab- or engine-forward mode
- Engine is running
- Header is disengaged
- Transmission is in either mid or high range

Moving the ground speed lever (GSL) out of neutral (brake off) will switch the white lights from field/work lights to road lights, if the switch is in the field/road lights position.

### 3.8 Windshield Wipers

The windshield wiper controls are located in the cab headliner. The illustration shows the controls in cab-forward mode.

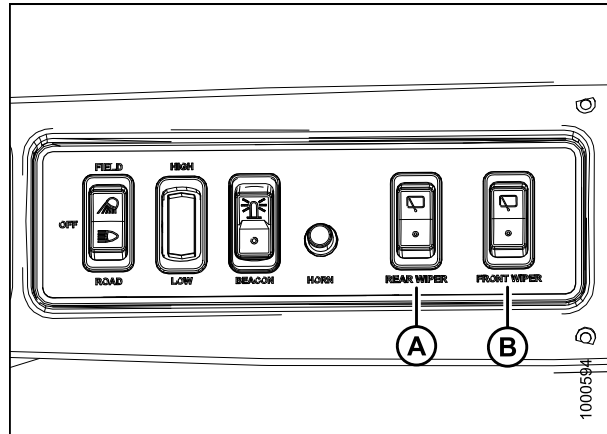

**Figure 3.29: Wiper Controls**

A - Rear Wiper

B - Front Wiper

### 3.9 Rear View Mirrors

Two outside-mounted, adjustable mirrors (A) provide a rear view when the windrower is in cab-forward mode.

A single interior-mounted mirror (B) provides a rear view in the engine-forward mode.

The mirror/light assembly (A) is designed to fold back if accidentally struck. A detent-type lock keeps it in place.

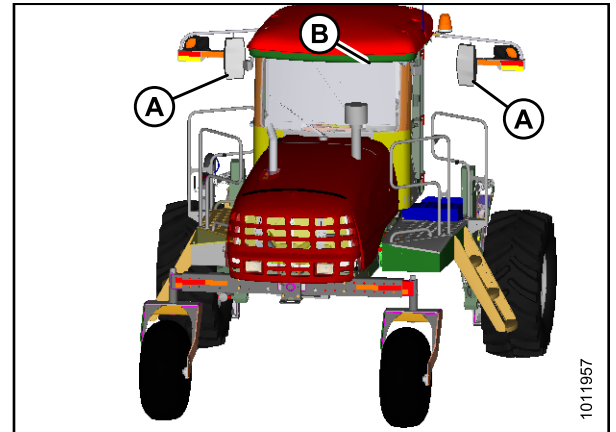

Figure 3.30: Mirrors

### 3.10 Cab Temperature

The cab environment is controlled by a climate control system that provides clean air-conditioned or heated air.

The heater/evaporator/blower assembly is located under the cab floorboard and is accessible from beneath the windrower.

#### 3.10.1 Heater Shut-Off

A shut-off valve (A) at the engine allows the cab heater to be isolated from the engine coolant.

The valve must be OPEN to provide heat to the cab but can be CLOSED for maximum cooling.

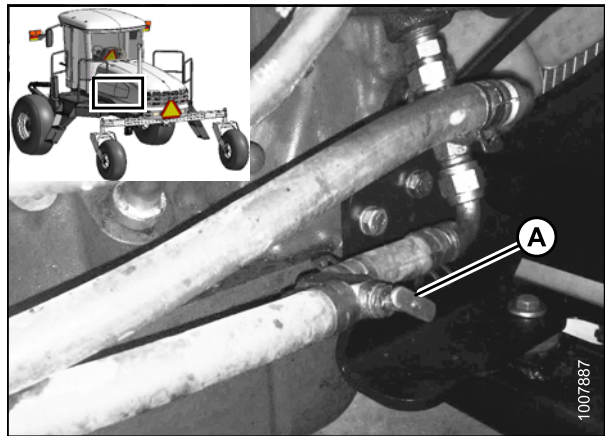

Figure 3.31: Heater Shut-Off Valve

#### 3.10.2 Air Distribution

Cab air distribution is controlled through adjustable air vents (A) located in the cab posts. The vents provide Operator ventilation.

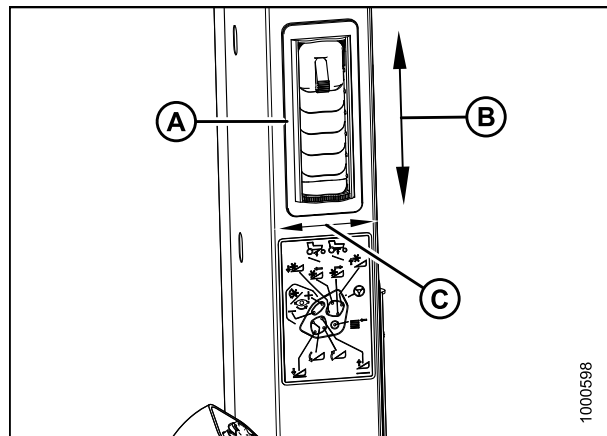

Figure 3.32: Adjustable Air Vents

A - Vent      B - Open/Close      C - Direction

### 3.10.3 Climate Controls

**A – BLOWER Switch** controls the blower speed.

- OFF / LOW / MEDIUM / HIGH

**B – Air Conditioning (A/C) Switch** controls A/C system.

- OFF: A/C does not operate.
- ON: A/C operates with blower switch ON.

**C – Outside Air Switch** controls the air source.

- FRESH AIR: Starts booster fan and filtered outside air is drawn into cab.
- RECIRCULATE: Stops booster fan and cab air is recirculated.

**D – TEMPERATURE Control Dial** controls cab temperature.

- Turning the dial clockwise: Increases temperature.
- Turning the dial counterclockwise: Decreases temperature.

**IMPORTANT:**

The refrigerant oil need to be distributed throughout the A/C system when starting the windrower after more than one week of storage. For instructions, refer to [Air Conditioning Compressor Coolant Cycling, page 162](#)

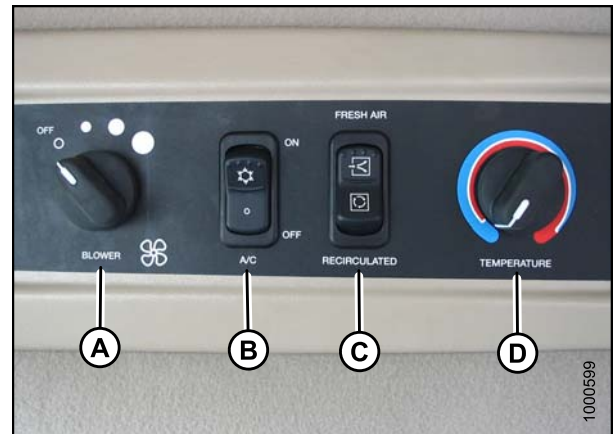

Figure 3.33: Climate Controls

### 3.11 Interior Lights

Two interior lights are installed in the cab headliner.

A low intensity LED light (A) is located directly overhead to provide ambient lighting if desired. It functions only when the key is in the RUN position. An ON/OFF switch is located on the light.

The other interior light (B) is located on the headliner switch panel and the push-ON, push-OFF button is located on the light. It functions at any time.

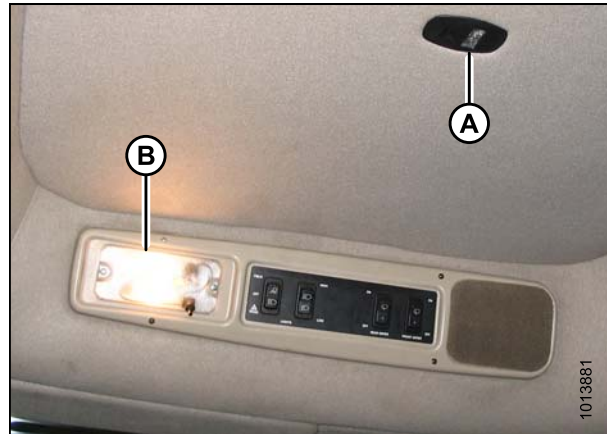

Figure 3.34: Interior Lights

### 3.12 Emergency Exit

The emergency exit window is located behind the operator console. An emergency exit sign (A) is located above the window.

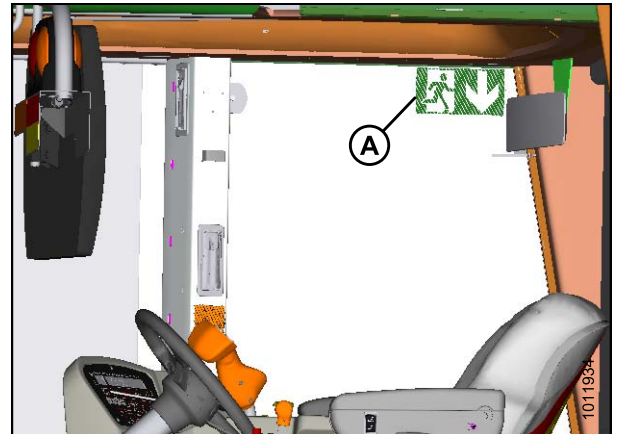

Figure 3.35: Emergency Exit Sign

To open the emergency exit window, do the following:

1. Release the window latch (A).
2. Remove the latch pin (B).
3. Push window open (C).

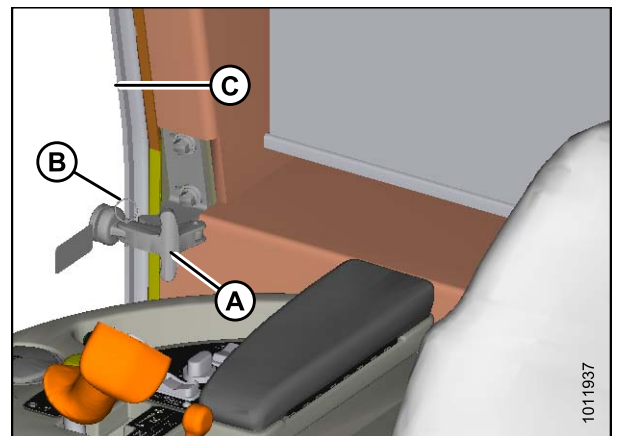

Figure 3.36: Emergency Exit Window

### 3.13 Operator Amenities

The operator's station includes the following amenities:

#### Operator's Console

- A - Auxiliary power outlet
- B - Utility tray (under armrest)
- C - Cigarette lighter
- D - Ashtray/cup holder
- E - Utility tray

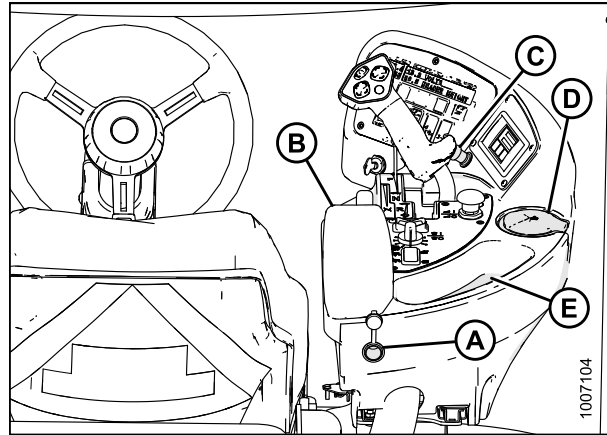

Figure 3.37: Console

#### Window Shades (Optional)

Retractable window shades (A) can be installed for the front and rear windows.

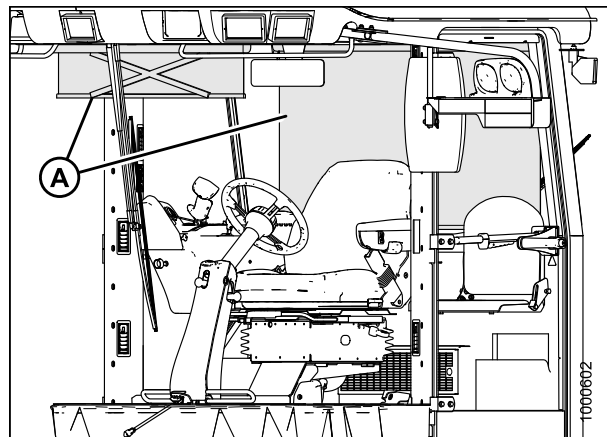

Figure 3.38: Window Shades

#### Auxiliary Outlets

Two auxiliary power outlets are located on either side of the wiper motor cover/storage tray behind the Operator (cab-forward mode).

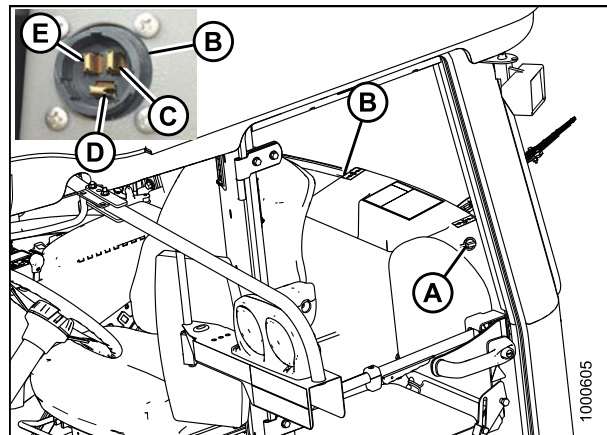

Figure 3.39: Auxiliary Power Outlets

- A - Auxiliary Power Outlet
- B - Auxiliary Power Outlet
- C - Battery Terminal
- D - Ground Terminal
- E - Switched Terminal



## OPERATOR'S STATION

### Manual Storage

A manual storage case (A) is located under the training seat.

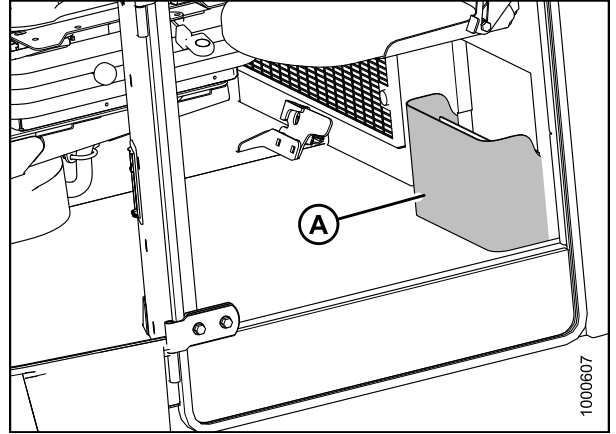

**Figure 3.40: Operator's Manual Storage**

### Coat Hook

A coat hook (A) is located above the training seat, left of the Operator.

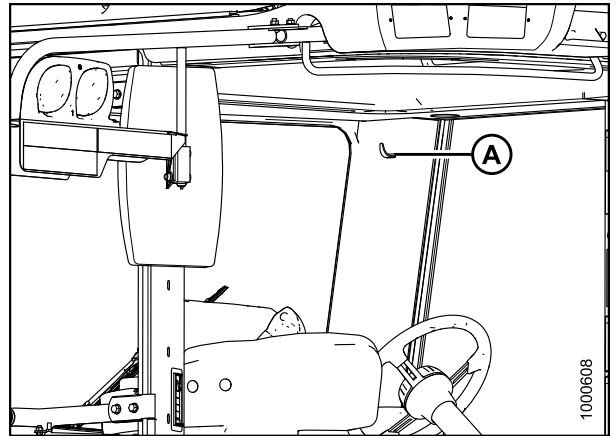

**Figure 3.41: Coat Hook**

## 3.14 Radio

A radio is available as optional equipment from your Dealer.

### 3.14.1 AM/FM Radio

A space (B) is provided in the cab headliner to accommodate the installation of an AM/FM radio that is available as optional equipment from your Dealer. In order to retain radio settings and preset memory with the battery disconnect turned off, select a radio with non-volatile settings memory.

Two pre-wired speakers (A) have been factory-installed in the headliner.

Operating instructions are supplied with the radio.

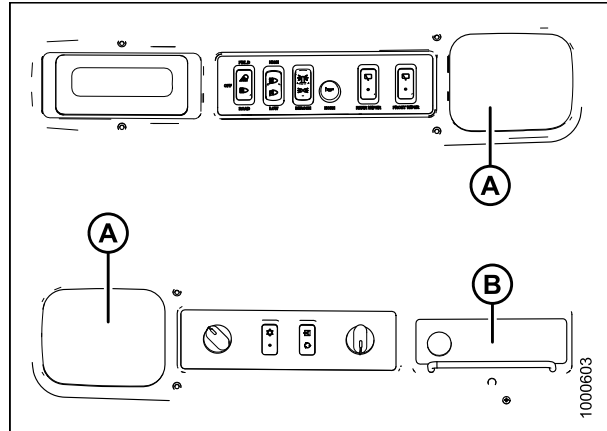

**Figure 3.42: Speakers in Roof Liner**

A - Speakers

B - Radio Mounting Location

### 3.14.2 Antenna Mounting

An optional base for a magnetic roof-mounted antenna is available from your Dealer.

**IMPORTANT:**

Antenna base can only be installed on the left cab-forward and right rear cab roof bolts.

Order antenna mount (MD #160288 [B]) or refer to [3.45: Template for Antenna Mount, page 63](#) for part dimensions to make an improvised version. A knockout (C) for the antenna lead is provided on the cab post.

1. Remove existing bolt (A).
2. Install antenna mount (B) and secure with bolt (A).

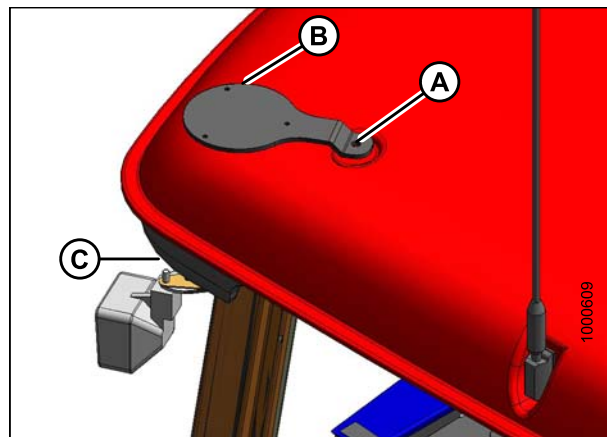

**Figure 3.43: Antenna Mount**

## OPERATOR'S STATION

The knockout (A) is located on the exterior right cab-forward rear corner post of the cab, under the roof, between the horn and the light.

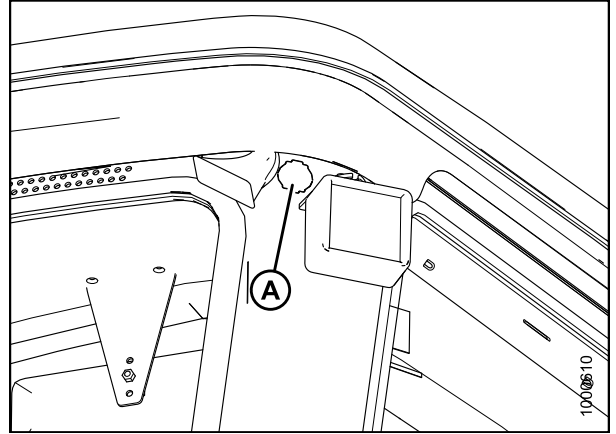

**Figure 3.44: Knockout Location in Cab**

To make your own mount, refer to dimensions template.  
Use 11 GA. or 3.0 mm steel sheet.

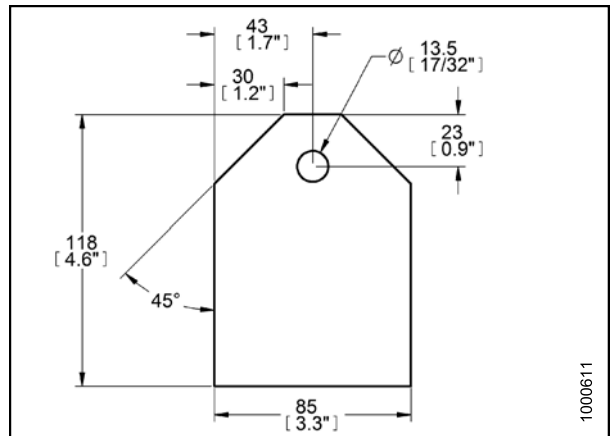

**Figure 3.45: Template for Antenna Mount**

### 3.15 Horn

The horn is activated by pushing button (A) located on the panel in the headliner.

Sound the horn three times prior to starting the engine.

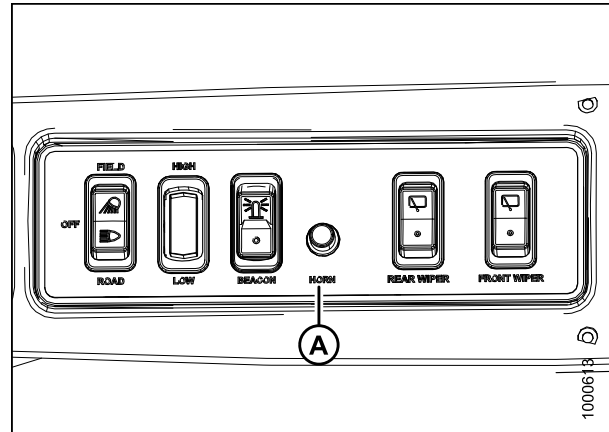

Figure 3.46: Horn Button Location

The horn (A) is located outside the cab on the rear right cab-forward corner of the cab, under the roof.

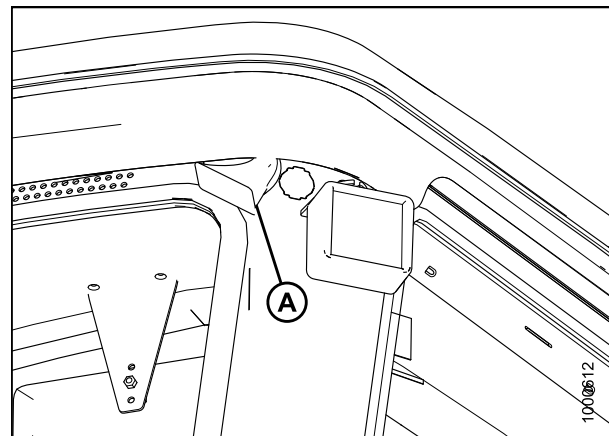

Figure 3.47: Horn Location

### 3.16 Engine Controls and Display Module

The following engine controls and display module are conveniently located on the operator's console.

#### Ignition Switch (A)

- ACC (Accessory): Fully counterclockwise
- OFF: All electrical systems OFF
- RUN: Clockwise
- START: Fully clockwise to crank engine: Release and switch returns to RUN
- REMOVE KEY WHEN WINDROWER NOT IN USE. KEY ALSO LOCKS DOORS

#### Fuel and Diesel Exhaust Fluid (DEF) Display Module (B)

- Fuel level monitoring
- DEF monitoring
- High Exhaust System Temp indicator (HEST)
- SCR system cleaning inhibit and forced indicator

#### NOTE:

For information about temperature warnings and alarms, refer to [Display Warnings and Alarms, page 90](#)

#### Throttle (C) controls engine speed

- FULL: Push lever forward
- OPERATING: Refer to [Driving Forward in Cab-Forward Mode, page 171](#)
- CLOSED: Pull lever back

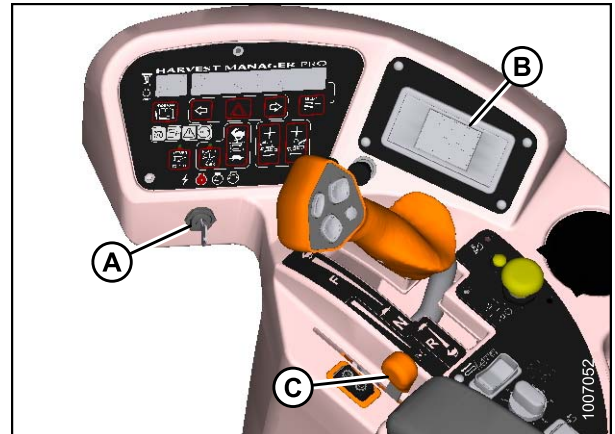

Figure 3.48: Engine Controls and DEF Display Module

### 3.16.1 Fuel and Diesel Exhaust Fluid (DEF) Display Module



**Figure 3.49: Fuel and Diesel Exhaust Fluid (DEF) Display Module**

A - Fuel and DEF Level

B - High Exhaust System Temperature (HEST)

C - Selective Catalytic Reduction (SCR) System Cleaning Inhibit

D - SCR System Cleaning Forced

#### Fuel and DEF level

- Scale level appears green when levels are between full and 1/8 and appears red when levels are between 1/8 and empty.
- When the levels are in the green range, switches (icons) appear white. When the levels are in the red range, switches (icons) turn black and are backlit with amber light. The amber lights blink when the tank level is depleted to 1/16.

#### **IMPORTANT:**

Running out of DEF will cause the engine to derate and will eventually limit throttle to idle.

**WARNING**

Do NOT park vehicle indoors when HEST lamp is on.

- When the HEST warning is active, the switch (icon) turns black and a warning lamp is backlit with amber light at location (A) (warning lamp not shown).
- The HEST lamp appears when the engine enters a selective catalytic reduction (SCR) system cleaning—this will not hinder normal vehicle operation.
- When the HEST warning is inactive, the switch (icon) is not visible and will appear entirely black (A).

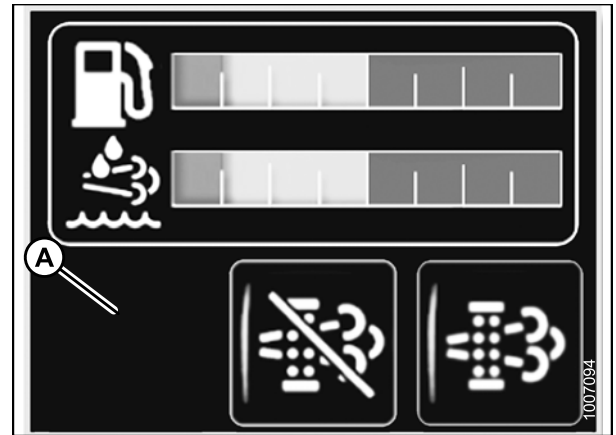

Figure 3.50: Inactive HEST Icon

**SCR System Cleaning Inhibit and SCR System Cleaning Forced**

SCR system cleaning is a high-temperature clean-out cycle to keep the after-treatment free of crystallized DEF.

A passive system cleaning may occur depending on engine duty cycles, and may last for 15–30 minutes. It will not have an impact on operation other than high exhaust temperature. A forced SCR system cleaning may be required for extensive clean-out (e.g., when the inhibit switch has been left on for a long period of time). The system will derate if the forced SCR system cleaning is not done.

- Switches (icons) (A) and (B) work as lamps and switches.
- The switches (icons) turn gray when the function is not active. When the function is active, the switches (icons) turn black and are backlit with amber light.
- To activate the functions, press and hold the switch (icon) (SCR system cleaning inhibit [A] or SCR system cleaning forced [B]) for three seconds. During the three-second interval, the fuel icon and gauge are replaced with the following red text at location (C), HOLD 3 SECONDS, and the red border turns white. After which, the fuel gauge returns and the white border starts blinking. The border reverts to solid red when the switch (icon) is released.

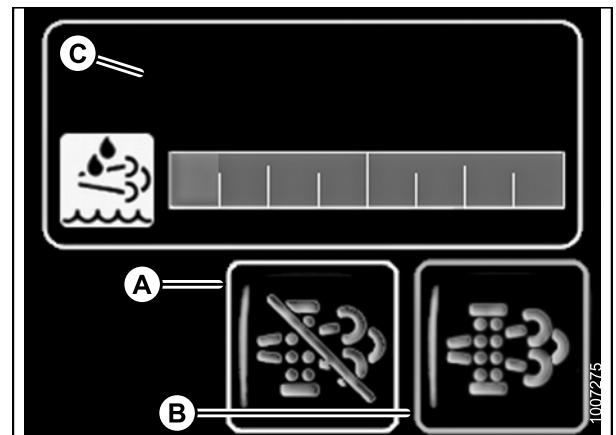

Figure 3.51: SCR System Cleaning Icons

**IMPORTANT:**

A forced system cleaning can only be initiated if the Operator is prompted by a flashing icon. A forced system cleaning cannot be initiated at other times.

## OPERATOR'S STATION

### IMPORTANT:

- SCR System Cleaning inhibit (A) allows the Operator to temporarily prevent the machine from performing an SCR System Cleaning. It should be used only when the environment is unsafe to allow high exhaust temperatures (e.g., inside of a building).
- SCR System Cleaning Forced (B) will rarely require activation by the Operator. If required, the switch (icon) will flash amber. If the SCR System Cleaning Forced switch (icon) begins to flash, park the windrower outside in a safe environment for high exhaust temperatures. Place the ground speed lever (GSL) in N-Detent, throttle to idle, and press and hold the SCR System Cleaning Forced switch (icon) for three seconds. The engine will then take over throttle control. During the three-second interval, the fuel icon and gauge will be replaced with the following red text, HOLD 3 SECONDS (C), and the red border will turn white. After which, the fuel gauge will return and the white border will start blinking. The border will revert to solid red when the switch (icon) is released.

### Tools Menu

To display the tools and brightness symbols, press and hold the fuel gauge display (A) for two seconds.

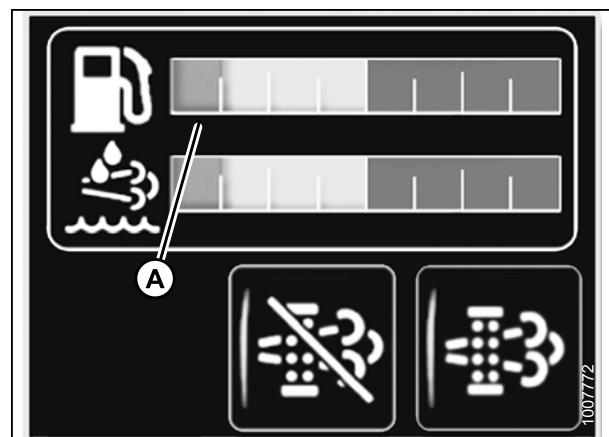

Figure 3.52: Fuel and Diesel Exhaust Fluid (DEF) Display Module

The fuel gauge display will be replaced by the tools (A) and brightness (B) symbols.

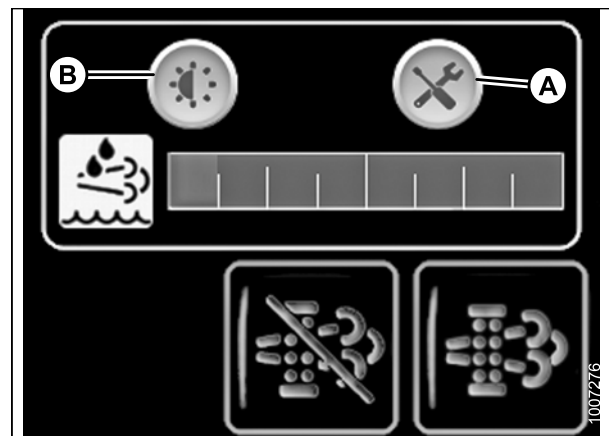

Figure 3.53: Tools and Brightness Symbols on Display



## OPERATOR'S STATION

By pressing the brightness symbol, the backlighting control (A) function is displayed.

Display will revert back to fuel gauge display if backlighting control function is not pressed for five seconds or if the DEF gauge display is pressed.

Press (-) to decrease backlighting and (+) to increase backlighting.

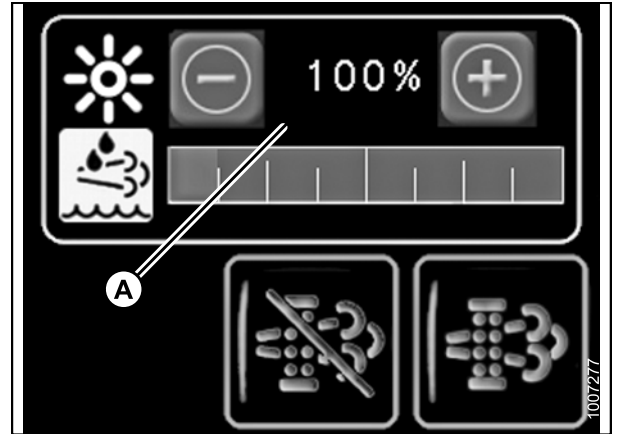

Figure 3.54: Backlighting Control Display

By pressing the tools symbol, the languages menu (A) is displayed.

The active language will be indicated by a white square (B) around the flag symbol and a text corresponding to the flag (C). Software version (D) is at the bottom of the languages menu screen.

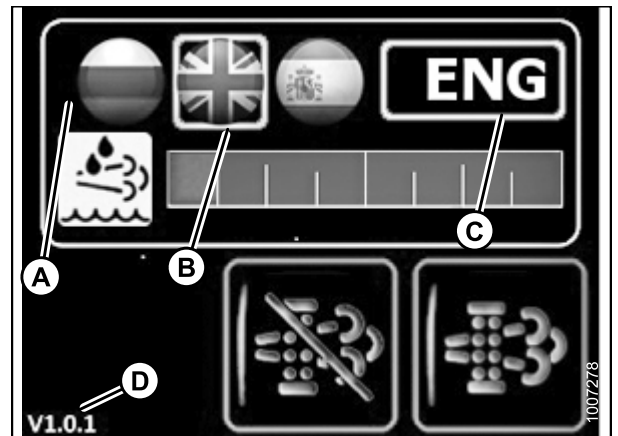

Figure 3.55: Language Display

### NOTE:

Languages available are Russian (A), English (B), and Spanish (C).

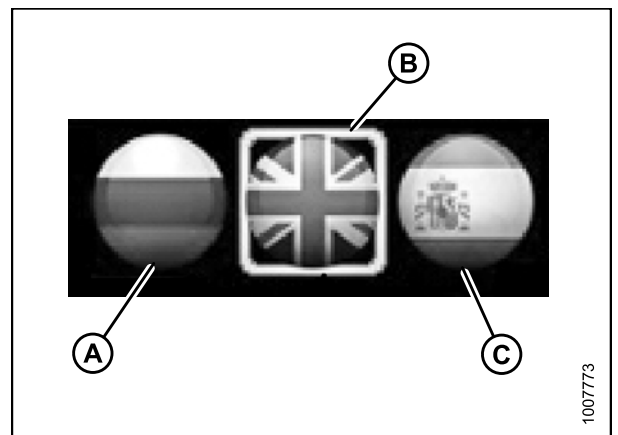

Figure 3.56: Language Icons on Display

## OPERATOR'S STATION

### *Audible Alarm*

An audible alarm indicates that something needs attention as shown in the fuel and diesel exhaust fluid (DEF) display module.

<b>Alarm Tone</b>	<b>Reason</b>	<b>Duration</b>
Ongoing intermittent moderate tone until the condition is corrected	When DEF or fuel level amber light first starts to blink (1/16th tank)	5 seconds
	When the <b>selective catalytic reduction SCR system cleaning INHIBIT</b> is active and the system calls for a passive SCR system cleaning	5 seconds, repeat every 30 minutes
Single moderate tone	At the end of the delay when a switch (icon) is activated	
	At the end of the delay for entering the brightness/tools menu	

### 3.17 Windrower Controls

**Console Controls:**

**A – TURN SIGNALS** activate turn signals on windrower and header

- Push-ON/Push-OFF

**B – GROUND SPEED LEVER (GSL)** controls speed and direction of movement

- F: Forward
- N: NEUTRAL
- N-DETENT: Engages neutral interlock, and applies park brake when steering locked in center
- R: Reverse

**C – HAZARD WARNING LIGHTS** activate signals on windrower and header

- Push-ON/Push-OFF

**D – GROUND SPEED RANGE SWITCH** shifts transmission speed range

- High range: 0–23 mph (37 km/h)  
ENGINE-FORWARD ONLY
- Mid range: 0–16 mph (25.7 km/h)  
CAB-FORWARD ONLY
- Low range: 0–11 mph (17.7 km/h)

**E – N-Detent**

**Autosteer Control:**

**A – AUTOSTEER ENGAGEMENT SWITCH** engages/disengages the automated steering system (if compatible system is installed)

- ENGAGE: Click to engage
- DISENGAGE: Turn steering wheel or click to disengage

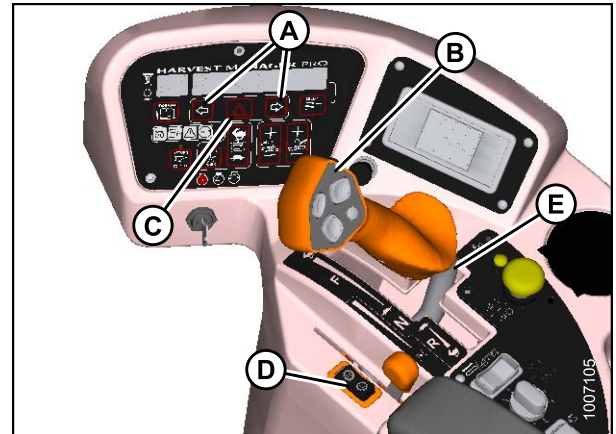

Figure 3.57: Console Controls

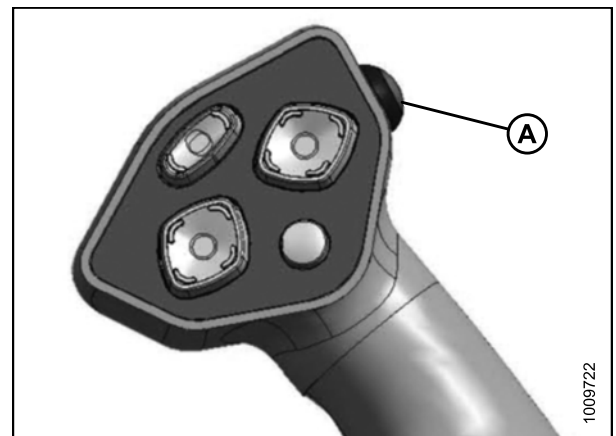
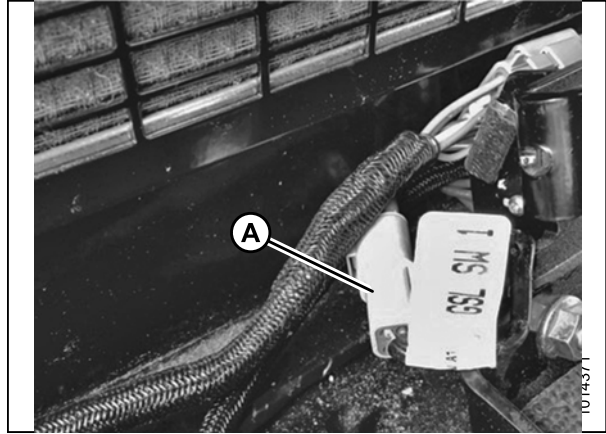

Figure 3.58: GSL

The autosteer engagement switch harness has two connectors and are located as follows:

## OPERATOR'S STATION

**GSL SW1 (A)** is located in the cab, beneath the floor mat at the engine-end seat position switch.



**Figure 3.59: Autosteer Harness SW1**

**GSL SW2 (A)** is located beneath the cab, between the fuel tank and evaporator box.

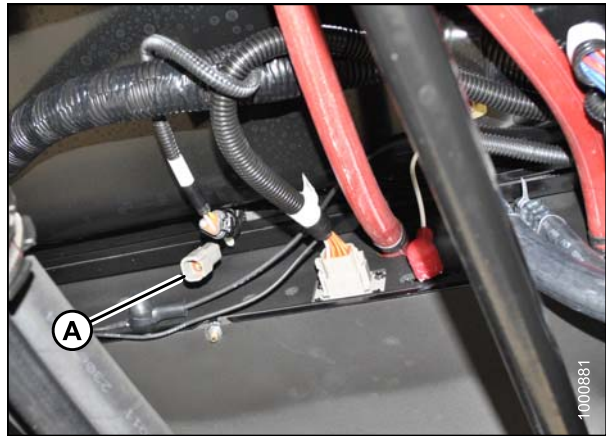

**Figure 3.60: Autosteer Harness SW2**

## 3.18 Header Controls

All header controls are conveniently located on the operator's console and on the ground speed lever (GSL) handle.

**NOTE:**

Some controls are optional equipment and may not be present in your unit. Some controls may be installed but nonfunctional for certain headers.

Refer to specific header sections in this manual for detailed operating procedures of all header controls.

### 3.18.1 Header Drive Switch

The HEADER DRIVE switch (A) engages and disengages the header drive.

To engage the header drive, pull up on the collar (B) and push down on the switch (A).

To disengage the header drive, push the switch down.

**IMPORTANT:**

Always move throttle lever back to IDLE before engaging header drive. Do **NOT** engage header with engine at full rpm.

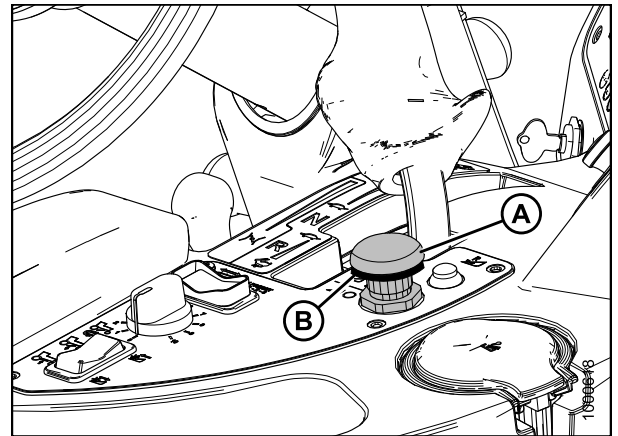

Figure 3.61: Header Drive Switch

### 3.18.2 Header Drive Reverse Button

**NOTE:**

The optional hydraulic reversing kit must be installed on draper headers with a conditioner and on auger headers. Rotary disc headers are factory-equipped with the ability to reverse.

- ENGAGE: Push and hold REVERSER button (B) and engage header with switch (A)
- DISENGAGE: Release REVERSER Button (B)

**NOTE:**

To engage forward operation, push switch (A) down and then up again.

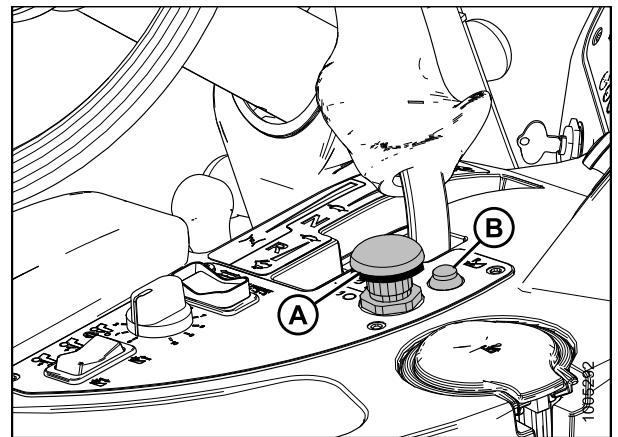

Figure 3.62: Header Drive Switches

### 3.18.3 Ground Speed Lever (GSL) Header Switches

The switches on the GSL (A) control the most common header functions.

**NOTE:**

A decal (B) identifying switch functions is located on the cab post above the operator's console.

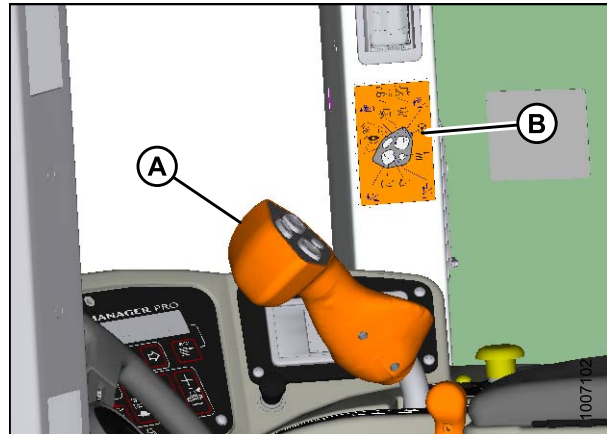

Figure 3.63: Decal on Cab post

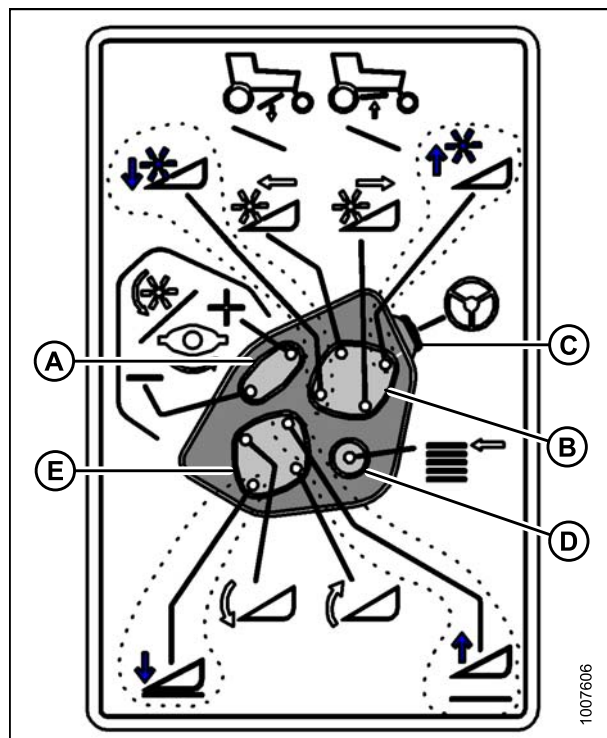

Figure 3.64: GSL Function Groups

- |                          |                      |
|--------------------------|----------------------|
| A - Reel Speed           | B - Reel Position    |
| C - Autosteer Engagement | D - Display Selector |
| E - Header Position      |                      |

## OPERATOR'S STATION

### Display Selector Switch

Pressing the display selector switch (A) selects and displays the settings on the cab display module (CDM) top line read-out for each of the header controls.

Press switch (A) to scroll through settings.

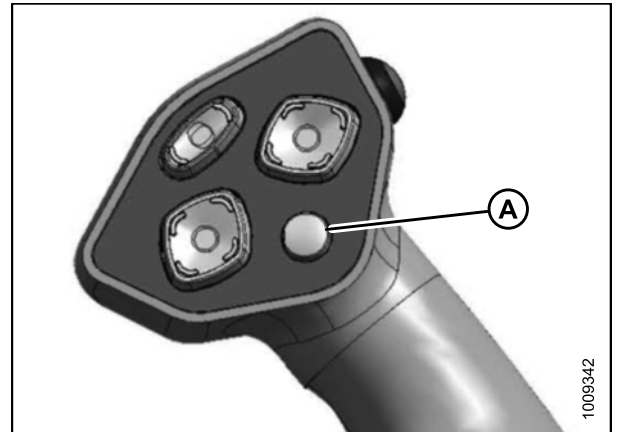

Figure 3.65: GSL

### Reel Position Switches

The reel position switches perform different functions depending on cab display module (CDM) programming and on which header is attached. For detailed switch operating modes, refer to one of the following sections that is specific to your header:

- Double Windrow Attachment (DWA) Position. Refer to [4.4.7 Double Windrowing, page 212](#).
- Reel Fore-Aft Position and Height on Draper Headers. Refer to:
  - [4.6.3 Adjusting the Reel Fore-Aft Position, page 260](#)
  - [4.6.4 Adjusting the Reel Height, page 260](#)
- Center-Link Assist Cylinder. Refer to:
  - [4.5.1 Attaching a D-Series Header, page 214](#)
  - [4.5.3 Attaching an A-Series Header, page 229](#)

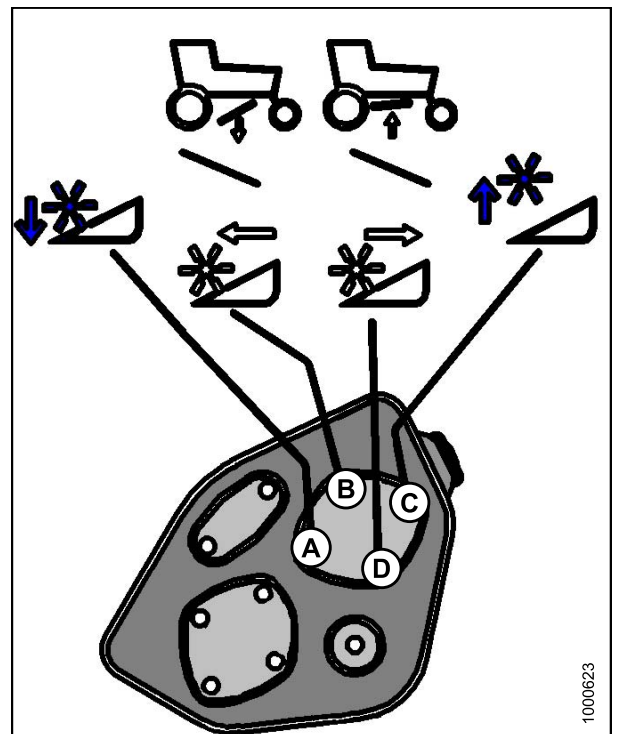

Figure 3.66: Ground Speed Lever

A - Reel Down  
B - Reel Forward  
C - Reel Up  
D - Reel Aft

## OPERATOR'S STATION

### Header Position Switches

Use the header position switches on the ground speed lever (GSL) to adjust the position of the header relative to the ground.

- To lower the header, press switch (A)
- To raise the header, press switch (C)
- To tilt the header down, press switch (B)
- To tilt the header up, press switch (D)

Release switch at desired position.

#### NOTE:

Refer to the section in this manual that is specific to your header for detailed switch operating modes.

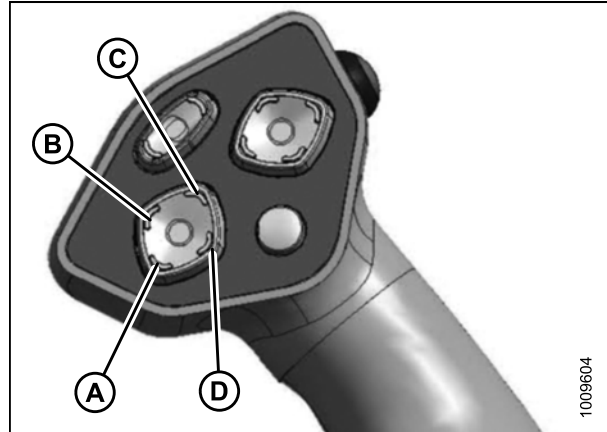

Figure 3.67: Ground Speed Lever

### Reel and Disc Speed Switches

Press and hold switch (A) to increase the reel or disc speed. Press and hold switch (B) to decrease the reel or disc speed. Release switch at desired speed.

#### Auger Header

- A-30 header: Not applicable
- A-40 header: Auger speed is automatically maintained when reel speed is changed

#### IMPORTANT:

Reel speed on auger header **MUST NOT EXCEED** 85 rpm. Auger speed **MUST NOT EXCEED** 320 rpm.

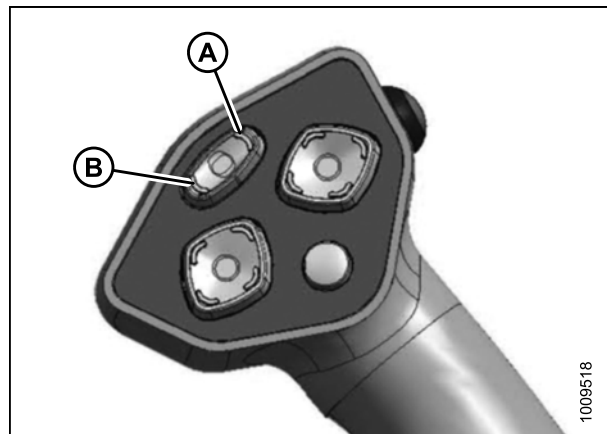

Figure 3.68: Ground Speed Lever

#### Draper Header

- Reel speed is limited in INDEX HEADER SPEED mode

#### Rotary Disc Header

- Conditioner speed automatically adjusts when DISC SPEED is changed



### 3.18.4 Console Header Switches

The operator's console contains switches for the following header functions:

#### *Deck Shift/Float Preset Switch*

#### **Draper Header with Deck Shift Option**

- Controls deck shifting and float settings for double windrowing options with a draper header

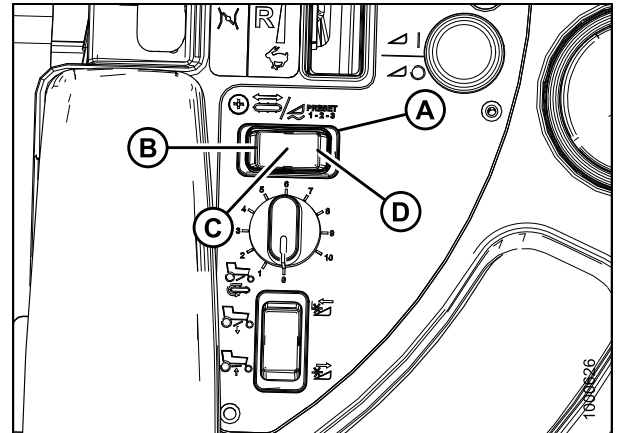

**Figure 3.69: Header Switches**

- |                                    |                         |
|------------------------------------|-------------------------|
| A - Deck Shift/Float Preset Switch | B - Left Side Delivery  |
| C - Center Delivery                | D - Right Side Delivery |

#### **Draper Header with Fixed Decks/Auger Header/Rotary Header**

- Selects pre-programmed header float settings. Refer to [Float Options, page 199](#) to learn how to preset the float.

**NOTE:**

Refer to the section in this manual that is specific to your header for detailed switch operating modes.

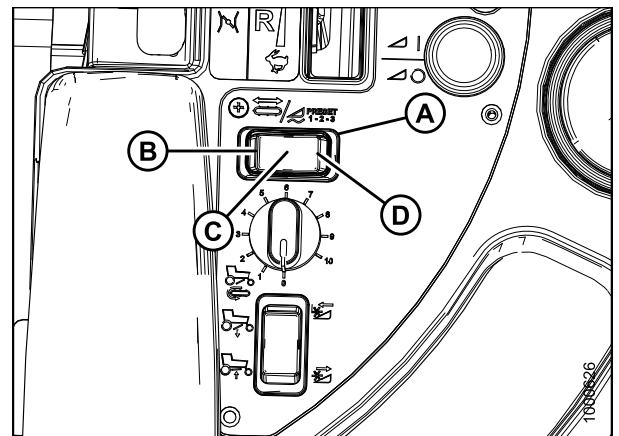

**Figure 3.70: Header Switches**

- |                                    |                    |
|------------------------------------|--------------------|
| A - Deck Shift/Float Preset Switch | B - Float Preset 1 |
| C - Float Preset 2                 | D - Float Preset 3 |

## OPERATOR'S STATION

### *Double Windrow Attachment (DWA) / Swath Roller Switch (if installed)*

#### **With Double Windrow Attachment**

- If switch (A) is installed in the console, the DWA deck is raised with switch in position (C) or lowered in position (B). The cab display module (CDM) must be programmed for this configuration. Refer to [Activating the Double Windrow Attachment \(DWA\)](#), page 113.

Switch (A) may be used in lieu of the DWA switches on the ground speed lever (GSL).

For more information on the DWA attachment and controls, refer to [4.4.7 Double Windrowing](#), page 212.

#### **With Swath Roller Attachment**

- The roller is raised by pressing switch (A) to position (C) or lowered with switch in position (B).

#### **NOTE:**

You may swap controls to the rocker switch or to the GSL handle, by changing the programming in the CDM. Refer to [3.19.6 Cab Display Module \(CDM\) Programming](#), page 93.

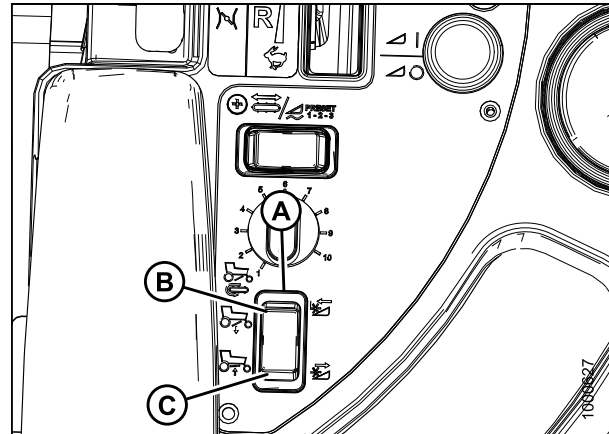

**Figure 3.71: Console Switches**

### 3.19 Cab Display Module (CDM)

#### 3.19.1 Engine and Windrower Functions

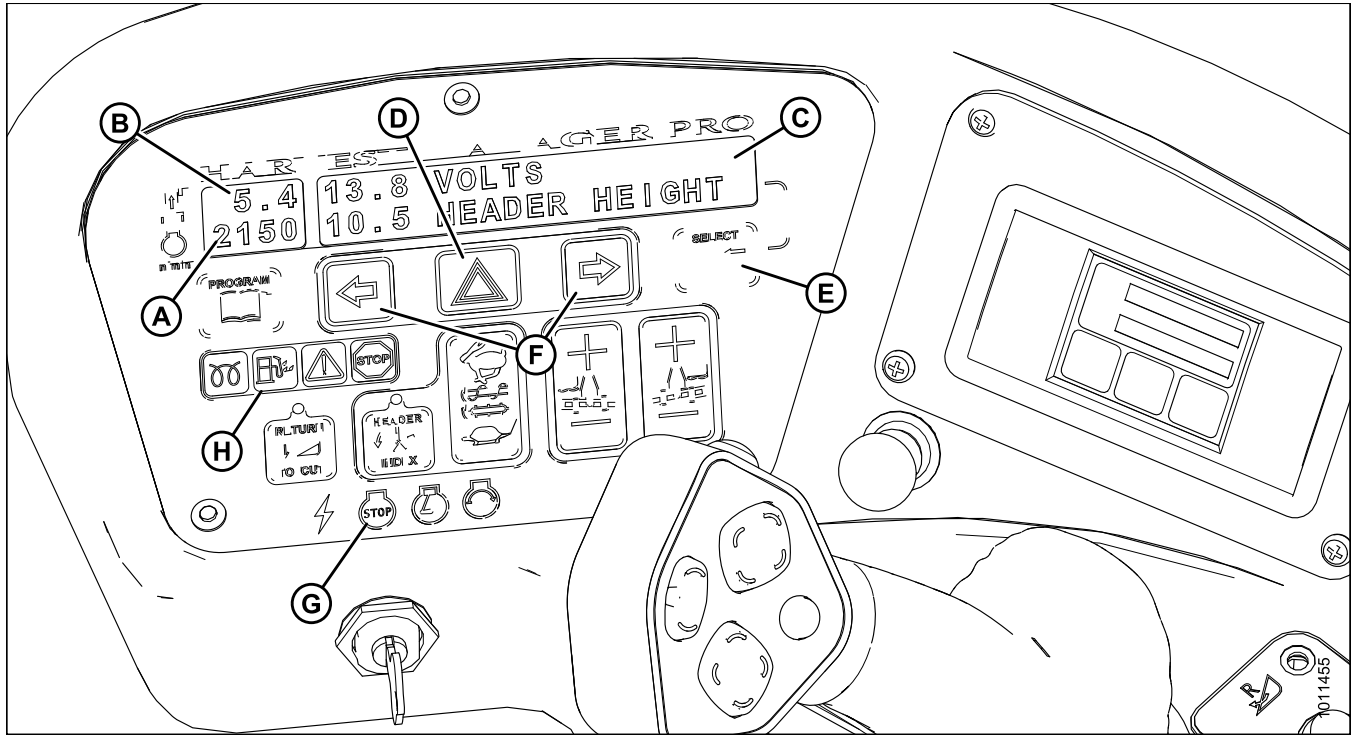

**Figure 3.72: Cab Display Module (CDM) Engine and Windrower Functions**

- (A) ENGINE RPM
- (B) GROUND SPEED – mph or km/h
- (C) DISPLAY – Engine/windrower functions
- (D) HAZARD WARNING LIGHTS SWITCH – Activates hazard warning lights, cancels turn signal
- (E) SELECT SWITCH – Allows Operator to select display item on lower line. Push to SELECT
- (F) TURN SIGNAL SWITCHES – Activates turn signals on windrower and header Push-ON/Push-OFF
- (G) IGNITION SWITCH POSITIONS – Accessory / Stop / Run / Start
- (H) ENGINE WARNING LIGHTS – Engine Pre-Heat / Water In Fuel / CAUTION / Stop Engine

### 3.19.2 Header Functions

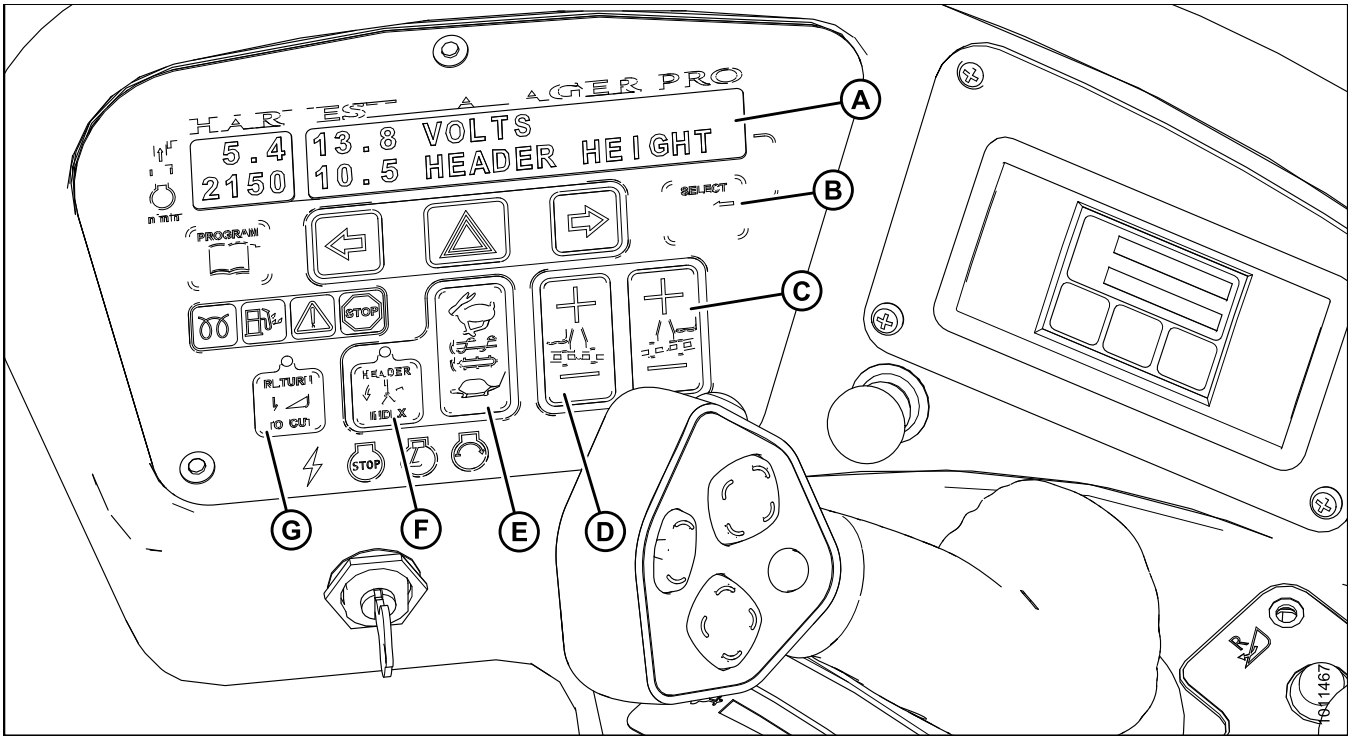

Figure 3.73: Cab Display Module (CDM)

- (A) DISPLAY – Header functions
- (B) SELECT SWITCH – Allows Operator to select display item on lower line. Push to SELECT.
- (C) FLOAT SWITCH – Header Right Side: Changes header float. The system remembers setting with deck shift option if activated with float setting switch. Push + to Increase. Push – to Decrease.
- (D) FLOAT SWITCH – Header Left Side: Changes header float. The system remembers setting with deck shift option if activated with float setting switch. Push + to Increase. Push – to Decrease.
- (E) AUGER/DRAPER SPEED ADJUST: Changes auger/draper speed INDEX with INDEX SWITCH ON. Changes auger/draper SPEED with INDEX SWITCH OFF. Push upper switch to increase. Push lower switch to decrease.
- (F) HEADER INDEX SWITCH: Links reel and conveyor speed to ground speed. Push-ON/Push-OFF.

**NOTE:**

Illuminates in ON position. (Header must be engaged)

- (G) RETURN TO CUT HEIGHT SWITCH: Allows cutting height preset. Push-ON/Push-OFF.

**NOTE:**

Illuminates in ON position. (Header must be engaged)

### 3.19.3 Operating Screens

The cab display module (CDM) and the windrower control module (WCM) provide information on several functions for the engine, header, and windrower. The information displayed in various operating modes is described in the following sections.

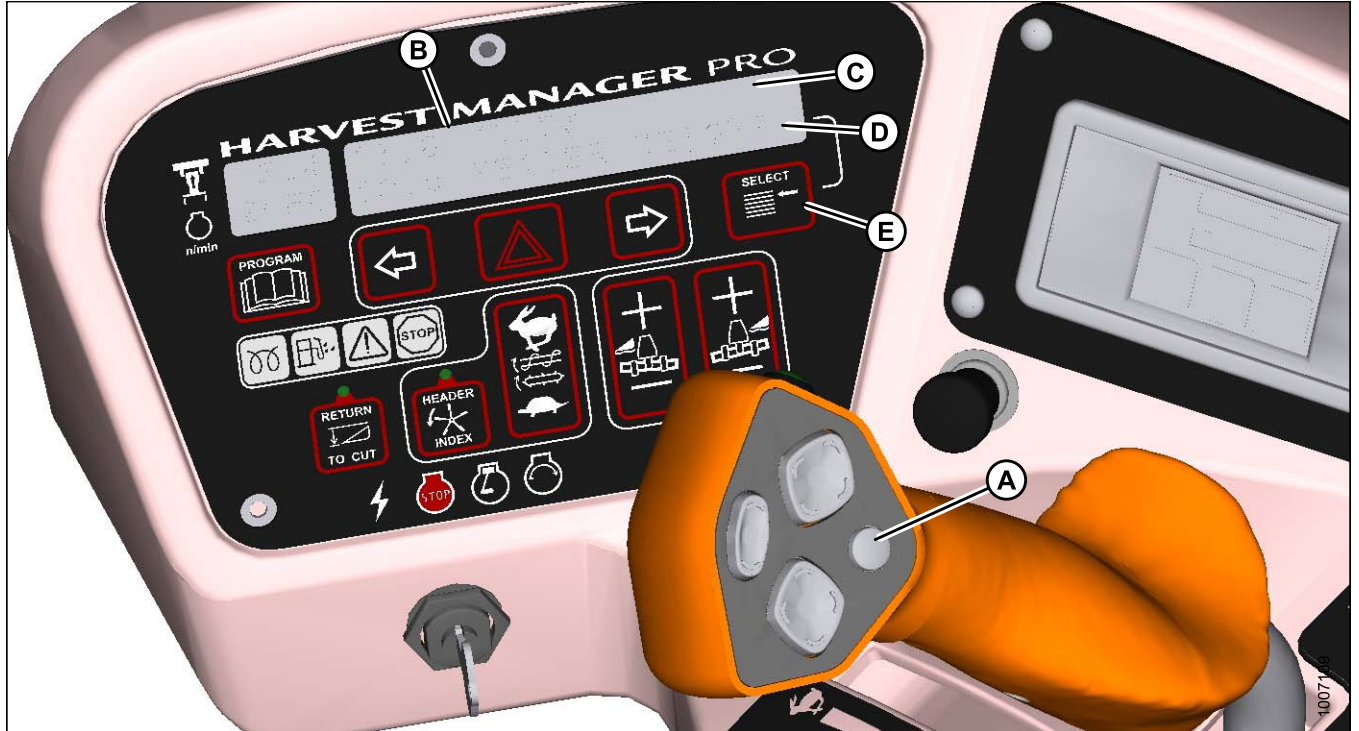

**Figure 3.74: CDM Operating Screen**

A - Display Selector for Upper Line  
D - CDM Lower Line

B - Display  
E - Display Selector for Lower Line

C - CDM Upper Line

*Ignition ON, Engine Not Running*

Display (Upper Line) (2–3 Seconds)	Description
HEADER DISENGAGED	Indicates HEADER DRIVE switch is OFF
IN PARK	Indicates ground speed lever (GSL) is in N-DETENT

## OPERATOR'S STATION

### *Engine-Forward, Engine Running*

Display	Description
ROAD GEAR (Upper Line)	Ground speed range switch in high range
#####.# ENGINE HRS (Upper or Lower Line)	Total engine operating time
#####.# UNIT HRS (Upper or Lower Line)	Total windrower operating time
#####.# HEADER HRS (Upper or Lower Line)	Total header operating time
#####.# TOTAL ACRES (Upper or Lower Line) #####.# TOTAL HECT (if Metric)	Total area cut by machine
##.# HEADER HEIGHT (Upper or Lower Line)	Distance setting (00.0–10.0) between cutterbar and ground
##.# HEADER ANGLE (Upper or Lower Line)	Angle setting (00.0–10.0) header relative to ground
### °C or F HYD OIL TEMP	Hydraulic oil temperature
##.# VOLTS (Upper or Lower Line)	Engine electrical system operating voltage
SCROLL (Lower Line)	Displays above items after two to three seconds; press SELECT to cancel

### *Cab-Forward, Engine Running, Header Disengaged*

Scroll through display with cab display module (CDM) switch or ground speed lever (GSL) switch.

Display (Lower or Upper Line)	Description
#####.# ENGINE HRS	Total engine operating time
#####.# UNIT HRS	Total windrower operating time
#####.# HEADER HRS	Total header operating time
##.# SUB ACRES ##.# SUB HECTARES (if metric)	Area cut since last reset. To reset, display SUB ACRES on lower line, and hold down Program switch until display resets (five to seven seconds)
#####.# TOTAL ACRES #####.# TOTAL HECT (if metric)	Total area cut by machine
##.# HEADER HEIGHT	Distance setting (00.0–10.0) between cutterbar and ground
##.# HEADER ANGLE	Angle setting (00.0–10.0) header relative to ground
##.# L FLOAT R ##.#	Float setting (0.0–10.0)
### °C or F HYD OIL TEMP	Hydraulic oil temperature
##.# VOLTS	Engine electrical system operating voltage
SCROLL (Lower Line)	Displays above items after two to three seconds; press SELECT to cancel

## OPERATOR'S STATION

*Cab-Forward, Engine Running, Header Engaged, Auger Header Index Switch OFF*

Scroll through display with cab display module (CDM) switch or ground speed lever (GSL) switch.

Display (Lower or Upper Line)	Description
#####.# ENGINE HRS	Total engine operating time
#####.# UNIT HRS	Total windrower operating time
#####.# HEADER HRS	Total header operating time
##.# ACRES/HOUR ##.# HECTARES/HOUR (If Metric)	Actual cutting rate in acres (hectares)/hour
###.# SUB ACRES ###.# SUB HECTARES (If Metric)	Area cut since last reset. To reset, display SUB ACRES on lower line, and hold down Program switch until display resets (five to seven seconds)
##### TOTAL ACRES ##### TOTAL HECT (If Metric)	Total area cut by machine
###.# REEL RPM ###.# REEL SENSOR	Reel rotational speed Sensor disabled. RPM and SENSOR alternate at one second intervals
###.# AUGER SPEED	Auger rotational speed (4.7–9.9)
#### KNIFE SPEED #### KNIFE SENSOR	Knife speed in strokes per minute Sensor disabled. SPEED and SENSOR alternate at one second intervals
###.# HEADER HEIGHT ###.# HEADER SENSOR	Distance setting (00.0–10.0) between cutterbar and ground Sensor disabled. HEIGHT and SENSOR alternate at one second intervals.
###.# HEADER ANGLE ###.# HEADER SENSOR	Angle setting (00.0–10.0) header relative to ground Sensor disabled. ANGLE and SENSOR alternate at one second intervals
###.# L FLOAT R ###.# FLOAT SENS DISABLED	Left and right float setting (0.0–10.0) Sensor disabled
LOAD ■■■■   #####	Bar graph representing hydraulic operating pressure. Full scale is preprogrammed overload pressure (2500–5000 psi). If sensor disabled, LOAD does not display <sup>5</sup>
###.# °C or F HYD OIL TEMP ###.# °C or F HYD TEMP	Hydraulic oil temperature Sensor disabled. TEMP and SENSOR alternate at one second intervals
###.# VOLTS	Engine electrical system operating voltage
SCROLL SUB-MENU (Lower Line Only) #### KNIFE SPEED ###.# HEADER HEIGHT LOAD ■■■■ ■■■■ #####	Displays sub-menu after two to three seconds. Press SELECT to cancel. Scroll through sub-menu display with CDM switch

5. The LOAD sensor to monitor knife/conditioner circuit pressure is optional. To monitor reel/auger circuit pressure, relocate sensor as per kit instruction MD #169031, which is available through your Dealer.

## OPERATOR'S STATION

*Cab-Forward, Engine Running, Header Engaged, Auger Header Index Switch ON*

Scroll through display with cab display module (CDM) switch or ground speed lever (GSL) switch.

Display (Lower or Upper Line)	Description
#####.# ENGINE HRS	Total engine operating time
#####.# UNIT HRS	Total windrower operating time
#####.# HEADER HRS	Total header operating time
##.# ACRES/HOUR ##.# HECTARES/HOUR (If Metric)	Actual cutting rate in acres (hectares)/hour
###.# SUB ACRES ###.# SUB HECTARES (If Metric)	Area cut since last reset. To reset, display SUB ACRES on lower line, and hold down Program switch until display resets five to seven seconds)
##### TOTAL ACRES ##### TOTAL HECT (If Metric)	Total area cut by machine
##.## ##.# REEL IND. ##.## REEL SENSOR	Reel peripheral speed along with ground speed in mph or km/h Sensor disabled. IND and SENSOR alternate at one second intervals
##.# AUGER SPEED ##.# AUGER SENSOR	Auger rotational speed (4.7–9.9) Sensor disabled. SPEED and SENSOR alternate at one second intervals
#### KNIFE SPEED #### KNIFE SENSOR	Knife speed In strokes per minute Sensor disabled. SPEED and SENSOR alternate at one second intervals
##.# HEADER HEIGHT ##.# HEADER SENSOR	Distance setting (00.0–10.0) between cutterbar and ground Sensor disabled. HEIGHT and SENSOR alternate at one second intervals
##.# HEADER ANGLE ##.# TILT SENSOR	Angle setting (00.0–10.0) header relative to ground. Sensor disabled. ANGLE and SENSOR alternate at one second intervals
##.# L FLOAT R ##.# FLOAT SENS DISABLED (If Sensor Disabled)	Left and right float setting (0.0–10.0) Sensor disabled
LOAD ■■■■  #####	Bar graph representing hydraulic operating pressure. Full scale is preprogrammed overload pressure (2500–5000 psi). If sensor disabled, LOAD does not display <sup>6</sup>
### °C or F HYD OIL TEMP ### °C or F HYD TEMP	Hydraulic oil temperature Sensor disabled. TEMP and SENSOR alternate at one second intervals

6. The LOAD sensor to monitor knife/conditioner circuit pressure is optional. To monitor reel/auger circuit pressure, relocate sensor as per kit instruction MD #169031, which is available through your Dealer.



## OPERATOR'S STATION

Display (Lower or Upper Line)	Description
##.# VOLTS	Engine electrical system operating voltage
SCROLL SUB-MENU (Lower Line Only) #### KNIFE SPEED ##.# HEADER HEIGHT LOAD ■■■■ ■■■■ ####	Displays sub-menu after two to three seconds. Press SELECT to cancel. Scroll through sub-menu display with CDM switch

*Cab-Forward, Engine Running, Header Engaged, Draper Header, Index Switch OFF*

Scroll through display with cab display module (CDM) switch or ground speed lever (GSL) switch.

Display (Lower or Upper Line)	Description
#####.# ENGINE HRS	Total engine operating time
#####.# UNIT HRS	Total windrower operating time
#####.# HEADER HRS	Total header operating time
##.# ACRES/HOUR ##.# HECTARES/HOUR (if metric)	Actual cutting rate in acres (hectares)/hour
###.# SUB ACRES ###.# SUB HECTARES (if metric)	Area cut since last reset. To reset, display SUB ACRES on lower line, and hold down program switch until display resets (five to seven seconds)
##### TOTAL ACRES ##### TOTAL HECT (if metric)	Total area cut by machine
##.# REEL MPH ##.# REEL KPH (if metric) ##.# REEL SENSOR (flashing)	Reel peripheral speed  Sensor disabled. MPH or KPH and SENSOR alternate at one second intervals
##.# DRAPER SPEED	Draper speed (0.0–11.0)
#### KNIFE SPEED #### KNIFE SENSOR	Knife speed In strokes per minute Sensor disabled. SPEED and SENSOR alternate at one second intervals
##.# HEADER HEIGHT ##.# HEADER SENSOR	Distance setting (00.0–10.0) between cutterbar and ground Sensor disabled. HEIGHT and SENSOR alternate at one second intervals
##.# HEADER ANGLE ##.# HEADER SENSOR	Angle setting (00.0–10.0). Header relative to ground Sensor disabled. ANGLE and SENSOR alternate at one second intervals
##.# L FLOAT R ##.# FLOAT SENS DISABLED	Left and right float setting (0.0–10.0) Sensor disabled
### °C or F HYD OIL TEMP ### °C or F HYD SENSOR	Hydraulic oil temperature Sensor disabled. TEMP and SENSOR alternate at one second intervals

## OPERATOR'S STATION

Display (Lower or Upper Line)	Description
LOAD ■■■■  ■■■■	Bar graph representing hydraulic operating pressure. Full scale is pre-programmed overload pressure (2500–5000 psi). If sensor disabled, LOAD does not display <sup>7</sup>
##.# VOLTS	Engine electrical system operating voltage
SCROLL SUB-MENU (Lower Line Only) ■■■■ KNIFE SPEED ##.# HEADER HEIGHT LOAD ■■■■ ■■■■  ■■■■ ##.## REEL MPH ##.# DRAPER SPEED	Displays sub-menu after two to three seconds. Press SELECT to cancel. Scroll through sub-menu display with CDM switch
KNIFE SPD OVERLOAD	Knife or disc speed drops below programmed value

### *Cab-Forward, Engine Running, Header Engaged, Draper Header Index Switch ON*

Scroll through display with cab display module (CDM) switch or ground speed lever (GSL) switch.

Display (Lower or Upper Line)	Description
#####.# ENGINE HRS	Total engine operating time
#####.# UNIT HRS	Total windrower operating time
#####.# HEADER HRS	Total header operating time
##.# ACRES/HOUR ##.# HECTARES/HOUR (if metric)	Actual cutting rate in acres (hectares)/hour
###.# SUB ACRES ###.# SUB HECTARES (if metric)	Area cut since last reset. To reset, display SUB ACRES on lower line and hold down Program switch until display resets (five to seven seconds)
##### TOTAL ACRES ##### TOTAL HECT (if metric)	Total area cut by machine
##.## ##.# REEL IND REEL.SENSOR	Reel peripheral speed along with ground speed in mph or km/h Sensor disabled. IND and SENSOR alternate at one second intervals
##.# ##.# DRAP INDX	Draper speed along with ground speed in mph or km/h
#### KNIFE SPEED #### KNIFE SENSOR	Knife speed in strokes per minute. Sensor disabled SPEED and SENSOR alternate at one second intervals
##.# HEADER HEIGHT ##.# HEADER SENSOR	Distance setting (00.0–10.0) between cutterbar and ground Sensor disabled. HEIGHT and SENSOR alternate at one second intervals
##.# HEADER ANGLE ##.# HEADER SENSOR	Angle setting (00.0–10.0) header relative to ground Sensor disabled. ANGLE and SENSOR alternate at one second intervals.
##.# L FLOAT R ##.# FLOAT SENS DISABLED	Left and right float setting (0.0–10.0) Sensor disabled

7. The LOAD sensor to monitor knife/conditioner circuit pressure is optional. To monitor reel/auger circuit pressure, relocate sensor as per kit instruction MD #169031, which is available through your Dealer.

## OPERATOR'S STATION

Display (Lower or Upper Line)	Description
LOAD ■■■■  ■■■■	Bar graph representing hydraulic operating pressure. Full scale is preprogrammed overload pressure (2500–5000 psi). If sensor disabled, LOAD does not display <sup>8</sup>
### VOLTS	Engine electrical system operating voltage
SCROLL SUB-MENU (lower line only) ■■■■ KNIFE SPEED ### HEADER HEIGHT LOAD ■■■■ ■■■■  ### ## REEL IND ### ## DRAP INDX	Displays sub-menu after two to three seconds. Press SELECT to cancel Scroll through sub-menu display with CDM switch
### REEL MIN RPM (lower line)	Reel speed drops below programmed set-point
MINIMUM (lower line)	Reel speed at zero ground speed

### *Cab-Forward, Engine Running, Header Engaged, Rotary Header Installed*

Scroll through display with cab display module (CDM) switch or ground speed lever (GSL) switch.

Display (Lower or Upper Line)	Description
##### ENGINE HRS	Total engine operating time
##### UNIT HRS	Total windrower operating time
##### HEADER HRS	Total header operating time
### ACRES/HOUR ### HECTARES/HOUR (If Metric)	Actual cutting rate in acres (hectares)/hour
### SUB ACRES ### SUB HECTARES (If Metric)	Area cut since last reset. To reset, display SUB ACRES on lower line, and hold down Program switch until display resets (five to seven seconds)
##### TOTAL ACRES ##### TOTAL HECT (If Metric)	Total area cut by machine
### DISC RPM ### DISC SENSOR	Disc rotational speed Sensor disabled. RPM and SENSOR alternate at one second intervals
### HEADER HEIGHT ### HEIGHT SENSOR	Distance setting (00.0–10.0) between cutterbar and ground Sensor disabled. HEIGHT and SENSOR alternate at one second intervals
### HEADER ANGLE ### HEADER SENSOR	Angle setting (00.0–10.0) header relative to ground Sensor disabled. ANGLE and SENSOR alternate at one second intervals
### L FLOAT R ### FLOAT SENS DISABLED	Left and right float setting (0.0–10.0) Sensor disabled

8. The LOAD sensor to monitor knife/conditioner circuit pressure is optional. To monitor reel/auger circuit pressure, relocate sensor as per kit instruction MD #169031, which is available through your Dealer.

## OPERATOR'S STATION

Display (Lower or Upper Line)	Description
LOAD ■■■■  ■■■■	Bar graph representing hydraulic operating pressure. Full scale is preprogrammed overload pressure (2500–5000 psi). If sensor disabled, LOAD does not display <sup>9</sup>
### °C or F HYD OIL TEMP ### °C or F HYD TEMP	Hydraulic oil temperature Sensor disabled. TEMP and SENSOR alternate at one second intervals
##.# VOLTS	Engine electrical system operating voltage
SCROLL SUB-MENU (Lower Line Only) #### DISC RPM ##.# HEADER HEIGHT LOAD ■■■■ ■■■■  ■■■■	Displays sub-menu after two to three seconds. Press SELECT to cancel. Scroll through sub-menu display with CDM switch

### Miscellaneous Operational Information

Scroll through display with cab display module (CDM) switch or ground speed lever (GSL) switch.

Display (Upper Line)	Description
HEADER DISENGAGED	Header drive is disengaged
##.# FOOT DISK	AUGER or DRAPER will appear in place of DISK, depending on type of header attached
IN PARK	GSL in N-DETENT position
< LEFT TURN ■	Indicates left turn when left arrow is pressed on CDM. Engine-forward mode only <sup>10</sup>
■ RIGHT TURN >	Indicates right turn when right arrow is pressed on CDM. Engine forward mode only <sup>11</sup>
■ HAZARD ■	Indicates hazard warning lights are on when hazard button is pressed on CDM
HEADER REVERSE	Header drive running in reverse
HEADER ENGAGED	Header drive engaged
ROAD GEAR	With HIGH RANGE selected on Console switch. Engine-forward only <sup>11</sup>

9. The LOAD sensor to monitor knife/conditioner circuit pressure is optional-installed. To monitor reel/auger circuit pressure, relocate sensor as per kit instruction MD #169031, which is available through your Dealer.

10. If road light kit is not installed, CDM will display E135 LEFT STOP LAMP as a malfunction in CAB-FORWARD mode.

11. If road light kit is not installed, CDM will display E134 RIGHT STOP LAMP as a malfunction in CAB-FORWARD mode.

### 3.19.4 Cab Display Module (CDM) Warning/Alarms

The CDM displays warnings and sounds alarms to notify of abnormal windrower status at startup when the ignition is turned ON, and at engine operating speeds above 500 rpm.

#### Engine Warning Lights



**Figure 3.75: CDM Engine Warning Lights**

A - Engine Pre-Heat  
D - Stop

B - Water in Fuel  
E - Display

C - Caution

- ENGINE PRE-HEAT: Illuminates yellow. Wait to start engine.
- WATER IN FUEL: Illuminates yellow. Service recommended.
- CAUTION: Illuminates yellow. Prompt attention is required. Refer to display code.
- STOP: Illuminates red. Stop engine immediately. Refer to display code.
- DISPLAY: Displays malfunction code. Refer to [8.4 Engine Error Codes, page 459](#) or your Dealer.

## OPERATOR'S STATION

### Display Warnings and Alarms

The Cab Display Module (CDM) warnings and alarms inform Operators of abnormal windrower conditions.

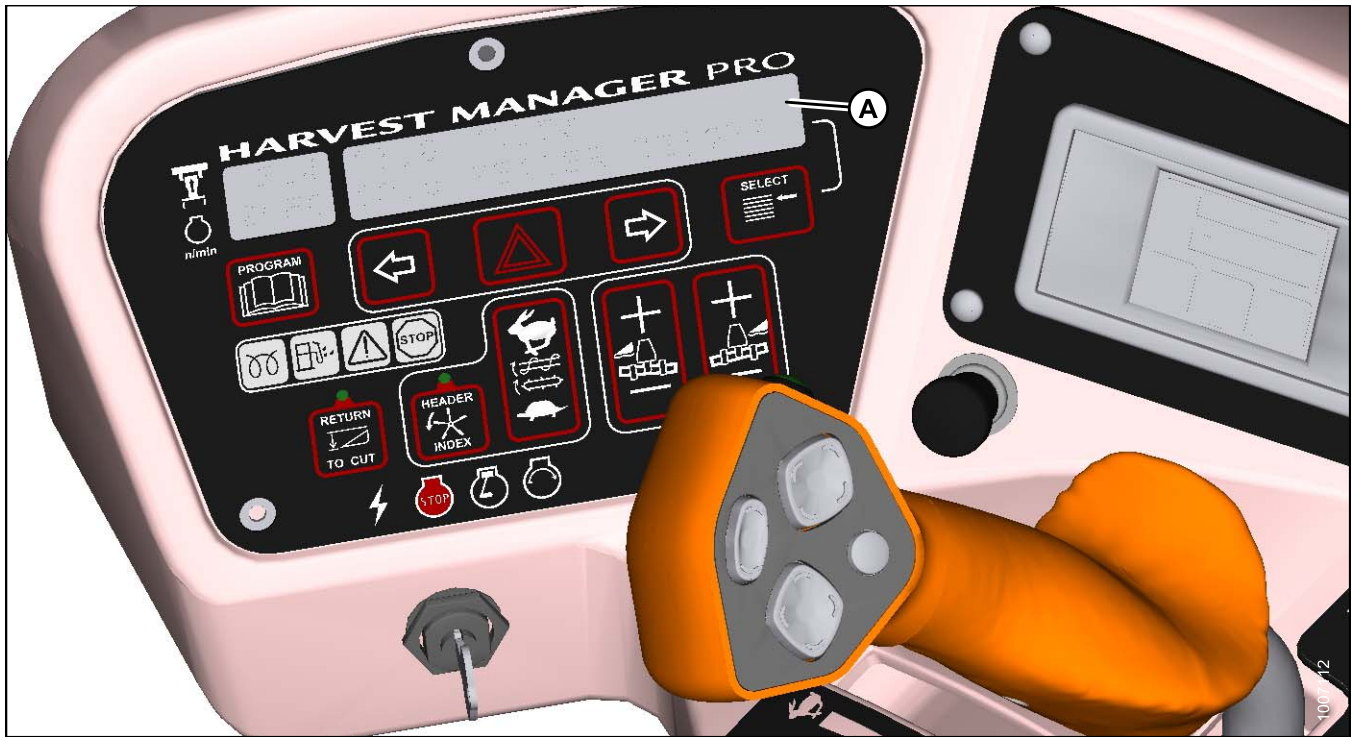

Figure 3.76: CDM Display Warnings and Alarms

Display (A)	Flashing	Alarm Tone	Description
BRAKE OFF	X	Short beep with each flash	Engine running, GSL in N-DETENT, brake pressure switch or brake switch relay fault.
BRAKE ON	X	Short beep with each flash	Ground speed lever (GSL) out of N-DETENT, but interlock switch remains closed to apply brake
BRAKE SW FAILURE	X	Short beep with each flash	Ignition ON/engine not running, brake switch and relay closed
CAB-FORWARD SW ON/ ENG-FORWARD SW ON	X	Messages flash alternately	Both seat switches activated
CENTER STEERING		Beeps at 2 per second	GSL or interlock switches not closed with key ON/engine OFF
DISENGAGE HEADER RE-ENGAGE <1800 RPM>	X	None	R80/R85 - Engine rpm above 1800 rpm when engaging header
ENGINE AIR FILTER	X	Single loud tone for 10 seconds, Repeats every 30 minutes until condition is corrected	Engine air filter requires servicing

## OPERATOR'S STATION

Display (A)	Flashing	Alarm Tone	Description
ENGINE TEMPERATURE	X	Ongoing intermittent moderate tone until temperature is below 215°F (102°C)	Engine temperature over 220°F (104°C)
HEADER DISENGAGED		None	Normal
DISENGAGE HEADER	X	None	Header switch is in the ON position when ignition switch is turned ON
HEADER OIL PRESS	X	Continuous loud tone until oil pressure is regained	Low header charge oil pressure causes header to shut down: header ON switch must be moved to OFF position and then to ON position to restart the header
HYDRAULIC FILTER	X	Single loud tone for 10 seconds, Repeats every 15 minutes until condition is corrected	Excessive pressure increase across hydraulic oil filter
### °C or F HYD OIL COLD	X	Tone sounds with each flash for 5 seconds and then stops for 1 minute: flashing continues if oil still cold after 1 minute, tone sounds again	Hydraulic oil temp <50°F (10°C)
### °C or F HYD OIL HOT	X	Tone with each flash for 5 seconds at 220°F (104°C) then tone stops for 1 minute while flashing continues: if oil still hot after 1 minute, tone sounds again. Flashing and steady tone at temperatures of 230°F (110°C) and higher	Hydraulic oil temp >220°F (104°C) but <230°F (110°C)
IN PARK	X	One short beep	GSL in N-DETENT, steering wheel centered, and brakes are engaged
KNIFE SPEED OVERLOAD	X	Short beep with each flash until condition is corrected	Machine overload: knife or disc speed drops below programmed value
LOCK SEAT BASE	X	None	Seat base not detected in cab or engine-forward position
LOW HYDRAULIC OIL	X	Continuous loud tone for 5 seconds, If condition is not rectified, single loud tone every 5 minutes	Low hydraulic oil level, header shuts down automatically if engaged: Header ON switch must be moved to OFF position and then to ON position to restart the header
NO HEADER		None	Header is not detected

## OPERATOR'S STATION

Display (A)	Flashing	Alarm Tone	Description
NO OPERATOR		Continuous tone	Operator not detected in seat with header engaged or out of N-DETENT: engine shutdown after 5 seconds
NO OPERATOR ENGINE SHUT DOWN		Continuous tone	Engine shutdown when Operator not detected in seat with machine moving under 5 mph (8 km/h)
NOT IN PARK	X	Short beep with each flash	GSL or interlock switches not closed with key ON/engine OFF
PLACE GSL INTO N		Beeps at 2 per second until corrected	GSL or interlock switches not closed with key ON/engine OFF
SLOW DOWN	X	Short beep with each flash	Ground speed is greater than or equal to 25 mph (40 km/h): Operator should pull back on the GSL to reduce ground speed
TRANS OIL PRESS	X	Continuous loud tone until oil pressure is regained	Low transmission charge oil pressure
### LOW VOLTS	X	Single loud tone for 10 seconds	Voltage below 11.5
### HIGH VOLTS	X	Single loud tone for 10 seconds	Voltage above 15.5

### 3.19.5 Programming Guidelines

Use the following guidelines when programming the cab display module (CDM):

- The monitoring system requires programming for each header.
- The **HEADER MUST BE ATTACHED TO THE WINDROWER** so the CDM recognizes the header type.
- The transmission must be in Neutral (GSL in N-DETENT) to program the system with the engine running.
- The ignition switch must be in the RUN position to program the system when the engine is not running.
- The system only needs to be programmed once for each header. Most functions are factory preset but the Operator can make changes to suit windrowing conditions or modifications to the machine.
- The windrower input values are provided in this manual. Header function values are in the operator's manual for the applicable header.
- The CDM must be in programming mode to view the program menus. Press PROGRAM and SELECT simultaneously on the CDM to enter programming mode. Exit programming mode at any time by pressing PROGRAM or by turning ignition to OFF.
- Refer to [3.19.6 Cab Display Module \(CDM\) Programming, page 93](#) for a detailed list of menu items.

**NOTE:**

Contact your MacDon dealer for information about software updates to the electronic modules. Your Dealer will have the necessary interface tools and access to the latest software upgrades.



### 3.19.6 Cab Display Module (CDM) Programming



Figure 3.77: CDM

A - Side Display  
D - Menu Item Scroll Forward

B - Main Display  
E - Menu Item Scroll Backward

C - Select Switch  
F - Program Switch

**Side Display:** Displays software revision status.

- Upper Line – C### (CDM)
- Lower Line – E### (WCM)

**Main Display:** Displays menu item and selection<sup>12</sup>.

- Upper Line – Menu Item
- Lower Line – Selection

**Select Switch:** Places monitor into Program Mode with program switch. Press to accept menu item and advance to next item.

**Menu Item Scroll Forward:** Displays value under menu item.

- Push to scroll forward
- Hold down for fast scroll<sup>13</sup>

**Menu Item Scroll Backward:** Displays value under menu item.

- Push to scroll backward
- Hold down for fast scroll<sup>13</sup>

**Program Switch:** Places monitor into program mode. Press while pressing select switch.

12. The current selection is flashing.

13. Fast scroll applies only when changing KNIFE SPEED, OVERLOAD PRESSURE, and TIRE SIZE.

## OPERATOR'S STATION

### NOTE:

Contact your MacDon Dealer for information regarding software updates to the electronic modules. Your Dealer will have the necessary interface tools and access to the latest software upgrades.

### NOTE:

The following menus are available when ignition key is set to RUN:

- WINDROWER SETUP
- CAB DISPLAY SETUP
- DIAGNOSTIC MODE

The CALIBRATE SENSORS menu is available only when engine is running.

### 3.19.7 Cab Display Options

The display and sound features of the cab display module (CDM) can be adjusted to suit each particular Operator.

### NOTE:

The procedures listed in this section are current for cab display module (CDM) software version C414 and windrower control module (WCM) E221. The WCM is supplied pre-loaded with the latest released version of the operating software. Any subsequent updates will be made available via internet download from the MacDon Dealer Portal (<https://portal.macdon.com>).

### NOTE:

Screens may appear differently if running newer or older versions of software, and not all features are available for every machine.

#### *Setting the Cab Display Language*

1. Turn ignition key to RUN, or start the engine.
2. Press PROGRAM (A) and SELECT (C) on cab display module (CDM) to enter Programming Mode.
  - WINDROWER SETUP? is displayed on the upper line.
  - NO/YES is displayed on the lower line.

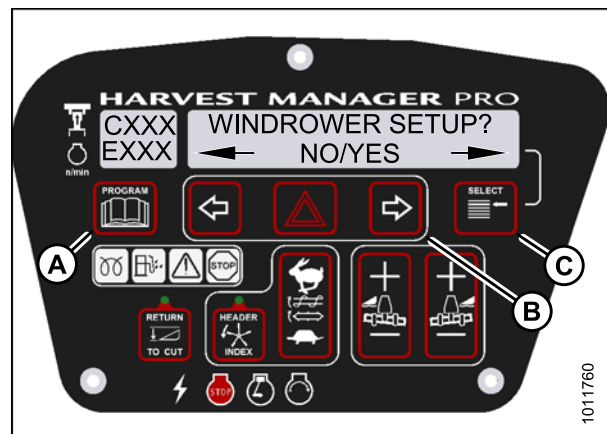

Figure 3.78: CDM Programming Buttons

## OPERATOR'S STATION

- Press SELECT (B) until CAB DISPLAY SETUP? is displayed on the upper line.
  - NO/YES is displayed on the lower line.

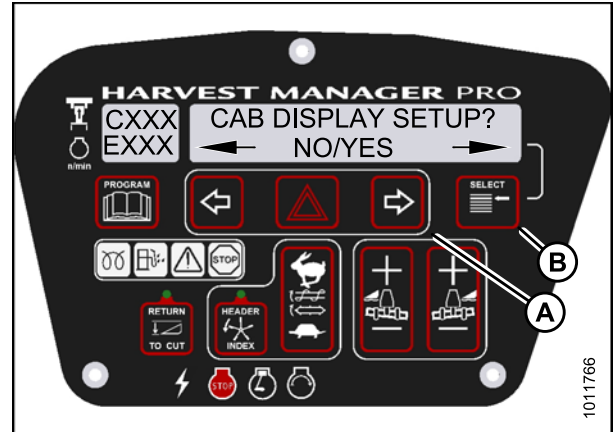

Figure 3.79: Cab Display Setup

- Press right (C) arrow select YES. Press SELECT (D).
  - DISPLAY LANGUAGE? is displayed on the upper line.
  - Default language is displayed on the lower line.
- Press left (B) or right (C) arrow to select preferred language.

**NOTE:**

English, Russian, and Spanish language options are available on windrowers. Not all machine options are available on all windrowers.

- Press PROGRAM (A) to exit Programming Mode or press SELECT (D) to proceed to next CAB DISPLAY SETUP? action.

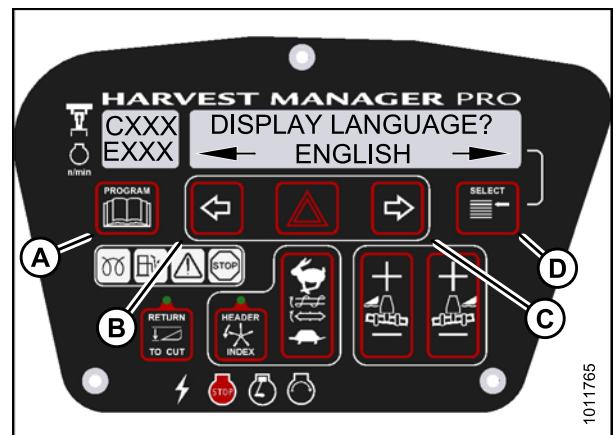

Figure 3.80: Display Language

### Changing the Windrower Display Units

- Turn ignition key to RUN, or start the engine.
- Press PROGRAM (A) and SELECT (C) on cab display module (CDM) to enter Programming Mode.
  - WINDROWER SETUP? is displayed on the upper line.
  - NO/YES is displayed on the lower line.

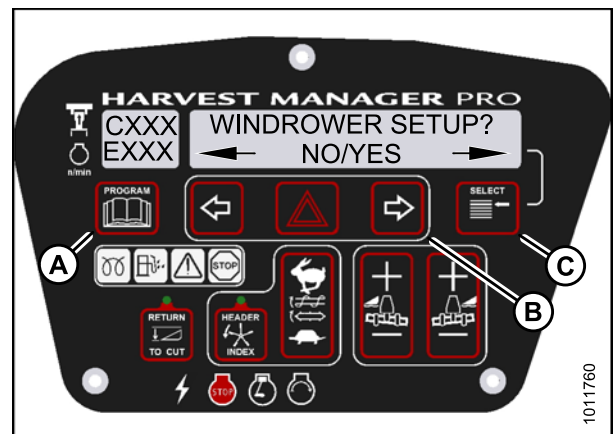

Figure 3.81: CDM Programming Buttons

## OPERATOR'S STATION

3. Press SELECT (B) until CAB DISPLAY SETUP? is displayed on the upper line.
  - NO/YES is displayed on the lower line.
4. Press right (A) arrow to select YES. Press SELECT (B).
  - DISPLAY LANGUAGE? is displayed on the upper line.

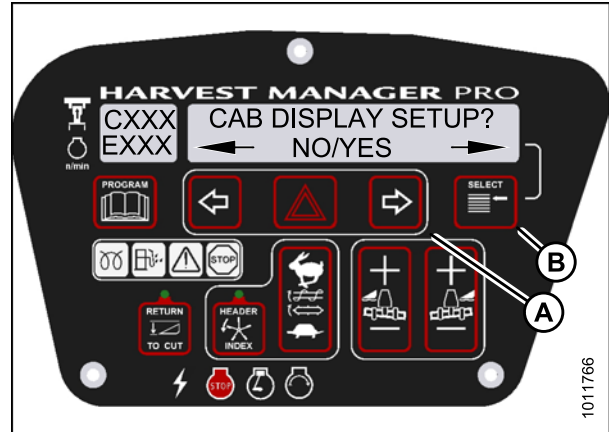

Figure 3.82: Cab Display Setup

5. Press SELECT (D) until DISPLAY UNITS? is displayed on the upper line.
  - Default setting is displayed on the lower line.
6. Press left (B) or right (C) arrow to select either METRIC or IMPERIAL speed display.
7. Press PROGRAM (A) to exit Programming Mode or press SELECT (D) to proceed to next CAB DISPLAY SETUP? action.

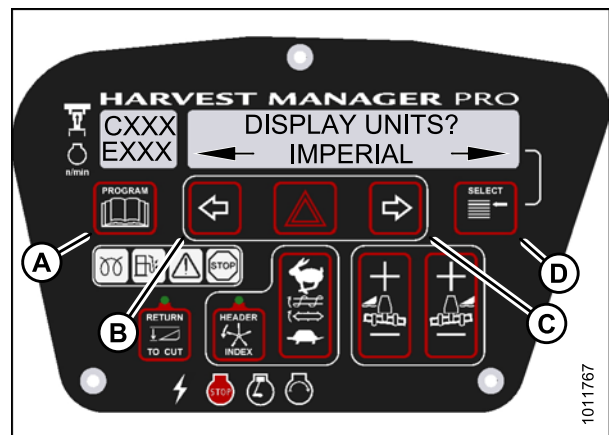

Figure 3.83: Display Units

### Adjusting the Cab Display Buzzer Volume

1. Turn ignition key to RUN, or start the engine.
2. Press PROGRAM (A) and SELECT (C) on cab display module (CDM) to enter Programming Mode.
  - WINDROWER SETUP? is displayed on the upper line.
  - NO/YES is displayed on the lower line.

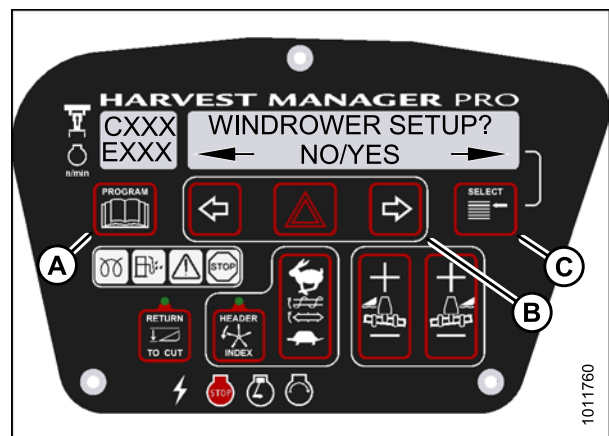

Figure 3.84: CDM Programming Buttons

## OPERATOR'S STATION

3. Press SELECT (B) until CAB DISPLAY SETUP? is displayed on the upper line.
  - NO/YES is displayed on the lower line.
4. Press right (A) arrow to select YES. Press SELECT (B).
  - DISPLAY LANGUAGE? is displayed on the upper line.

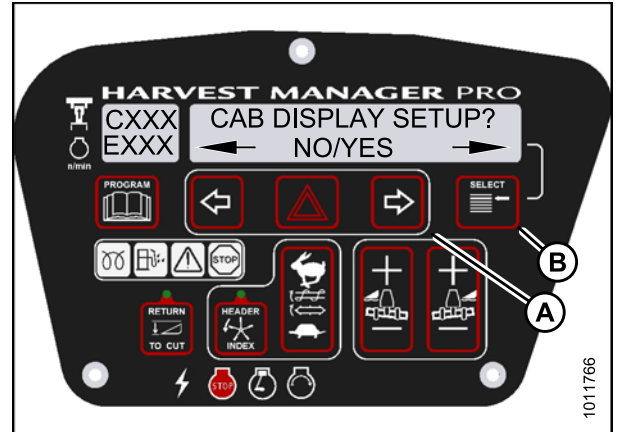

Figure 3.85: Cab Display Setup

5. Press SELECT (D) until BUZZER VOLUME is displayed on the upper line.
  - Previous setting is displayed on the lower line.
6. Press left (B) or right (C) arrows to adjust buzzer volume.
7. Press PROGRAM (A) to exit Programming Mode or press SELECT (D) to proceed to next CAB DISPLAY SETUP? action.

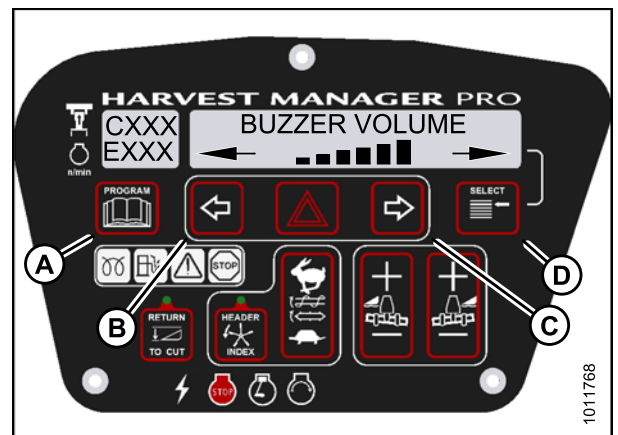

Figure 3.86: Buzzer Volume

### Adjusting the Cab Display Backlighting

The backlighting feature brightens the display screen helping you read the cab display module (CDM) in low light situations.

1. Turn ignition key to RUN, or start the engine.
2. Press PROGRAM (A) and SELECT (C) on cab display module (CDM) to enter Programming Mode.
  - WINDROWER SETUP? is displayed on the upper line.
  - NO/YES is displayed on the lower line.

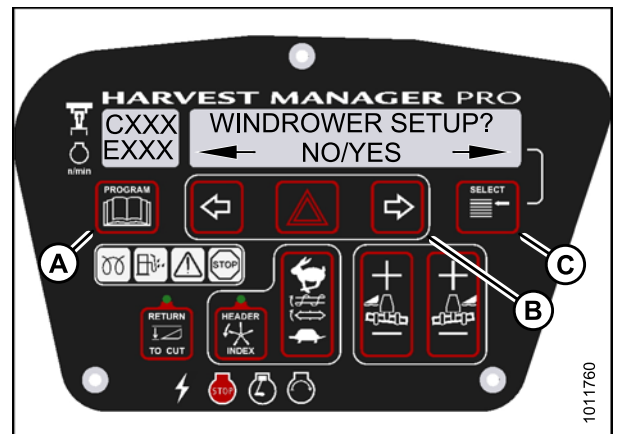

Figure 3.87: CDM Programming Buttons

## OPERATOR'S STATION

3. Press SELECT (B) until CAB DISPLAY SETUP? is displayed on the upper line.
  - NO/YES is displayed on the lower line.
4. Press right (A) arrow to select YES. Press SELECT (B).
  - DISPLAY LANGUAGE? is displayed on the upper line.

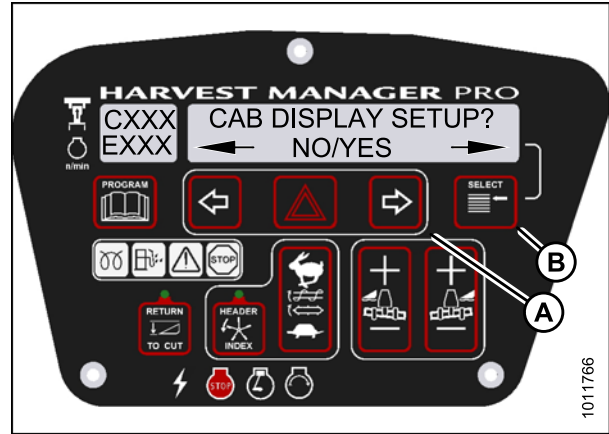

Figure 3.88: Cab Display Setup

5. Press SELECT (D) until BACKLIGHTING is displayed on the upper line.
  - Default setting is displayed on the lower line.
6. Press left (B) or right (C) arrows to adjust display backlighting.
7. Press PROGRAM (A) to exit Programming Mode or press SELECT (D) to proceed to next CAB DISPLAY SETUP? action.

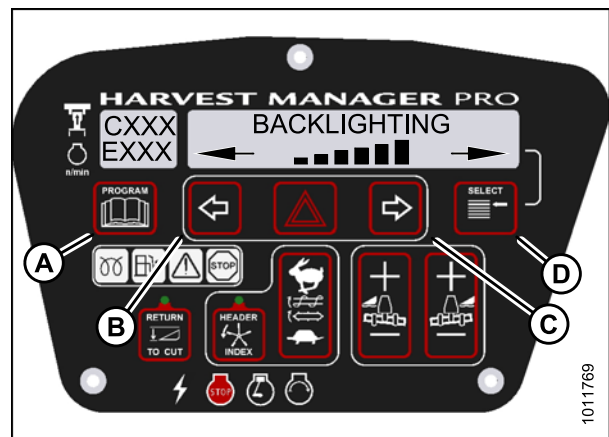

Figure 3.89: Backlighting

### Adjusting the Cab Display Contrast

1. Turn ignition key to RUN, or start the engine.
2. Press PROGRAM (A) and SELECT (C) on cab display module (CDM) to enter Programming Mode.
  - WINDROWER SETUP? is displayed on the upper line.
  - NO/YES is displayed on the lower line.

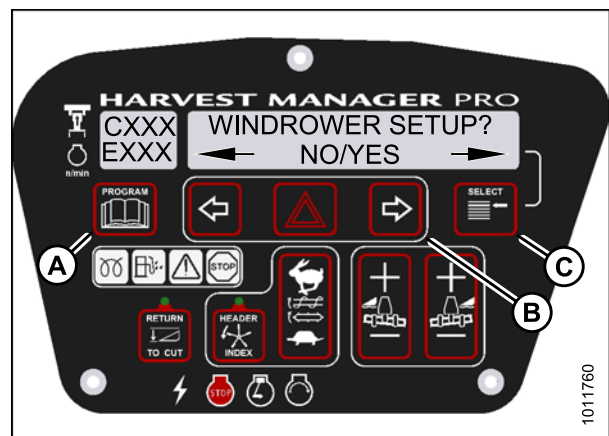

Figure 3.90: CDM Programming Buttons

## OPERATOR'S STATION

3. Press SELECT (B) until CAB DISPLAY SETUP? is displayed on the upper line.
  - NO/YES is displayed on the lower line.
4. Press right (A) arrow to select YES. Press SELECT (B).
  - DISPLAY LANGUAGE? is displayed on the upper line.

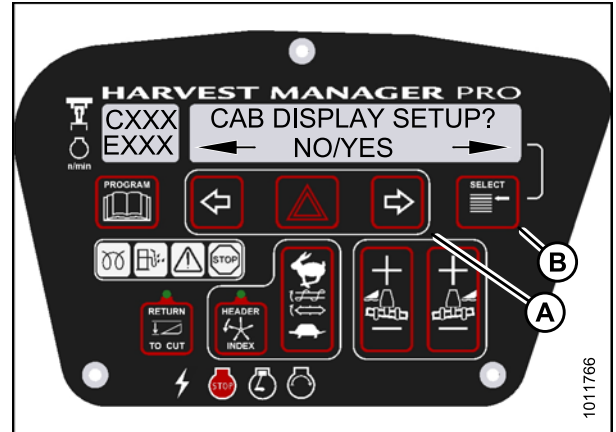

Figure 3.91: Cab Display Setup

5. Press SELECT (D) until DISPLAY CONTRAST is displayed on the upper line.
  - Default setting is displayed on the lower line.
6. Press left (B) or right (C) arrows to adjust display contrast.
7. Press PROGRAM (A) to exit Programming Mode or press SELECT (D) to proceed to next CAB DISPLAY SETUP? action.

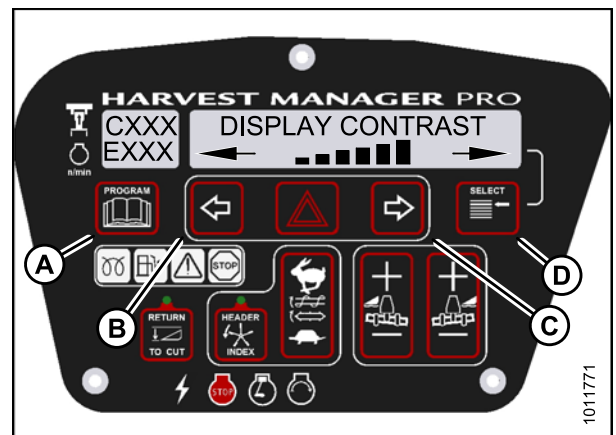

Figure 3.92: Display Contrast

### 3.19.8 Calibrating the Header Sensors

Sensor calibration programs the windrower control module (WCM) with settings for the attached header.

#### *Calibrating the Header Height Sensor*

#### **NOTE:**

- The header **MUST** be attached to the windrower to perform this procedure. The cab display module (CDM) automatically adjusts its programming for each header. For more information, refer to [4.5 Attaching and Detaching Headers, page 214](#).
- The engine **MUST** be running to perform this procedure.

## OPERATOR'S STATION

1. Turn ignition key to RUN, or start the engine.
2. Press PROGRAM (A) and SELECT (C) on cab display module (CDM) to enter Programming Mode.
  - WINDROWER SETUP? is displayed on the upper line.
3. Press SELECT (C) until CALIBRATE SENSORS? is displayed on the upper line.
  - NO/YES is displayed on the lower line.

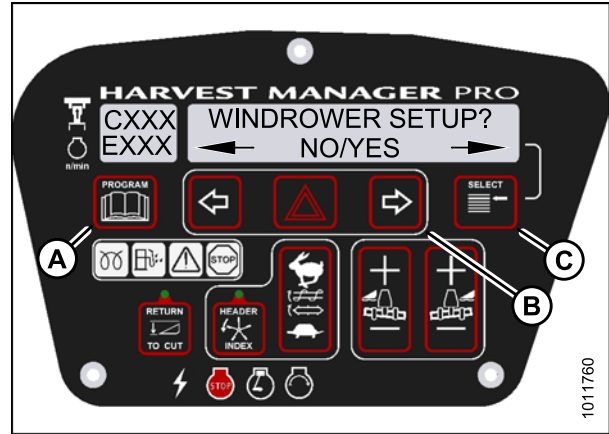

Figure 3.93: CDM Programming Buttons

4. Press right (B) arrow to select Yes. Press SELECT (C).
  - TO CALIBRATE SELECT is displayed in upper line.
5. Press left (A) or right (B) arrow until HEADER HEIGHT is displayed on the lower line. Press SELECT (C).
  - CALIBRATING HEIGHT is displayed on the upper line.
  - RAISE HEADER HOLD is displayed on the lower line.

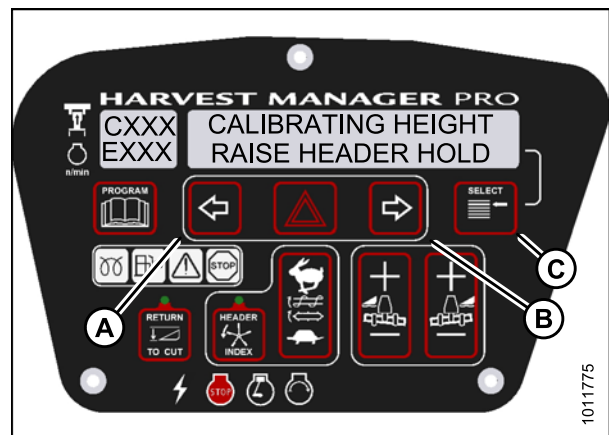

Figure 3.94: Header Height Calibration



**CAUTION**

Check to be sure all bystanders have cleared the area.

6. Press and hold the HEADER UP (C) button on the ground speed lever (GSL).
  - CALIBRATING HEIGHT is displayed on the upper line.
  - RAISE HEADER HOLD is displayed on the lower line.

**NOTE:**

The word HOLD will flash during calibration. RAISE HEADER DONE will display on the lower line once calibration is complete.

7. Release the HEADER UP (C) button.
  - HEIGHT SENSOR CAL is displayed on the upper line.
  - PRESS LOWER HEADER is displayed on the lower line.

8. Press and hold HEADER DOWN (A) button on GSL.

**NOTE:**

The word HOLD will flash during calibration. HT SENSOR COMPLETE will display on the lower line once calibration is complete.

9. Release HEADER DOWN (A) button.
  - TO CALIBRATE SELECT is displayed on the upper line.
  - HEADER HEIGHT is displayed on the lower line.
10. Press right arrow to select next header sensor calibration or STOP & EXIT. Press SELECT. Refer to [Calibrating the Header Tilt Sensor, page 102](#) or [Calibrating the Header Float Sensors, page 104](#).
11. Press PROGRAM to exit Programming Mode.

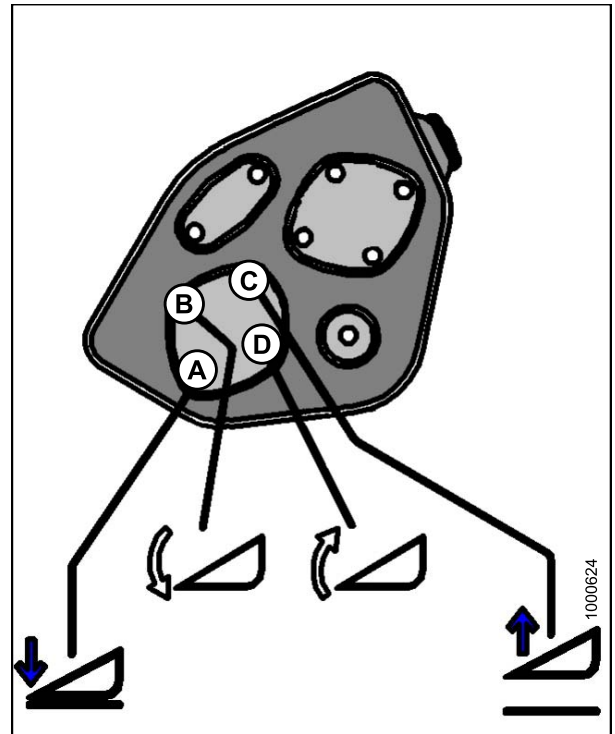

Figure 3.95: Header Height Controls on Ground Speed Lever

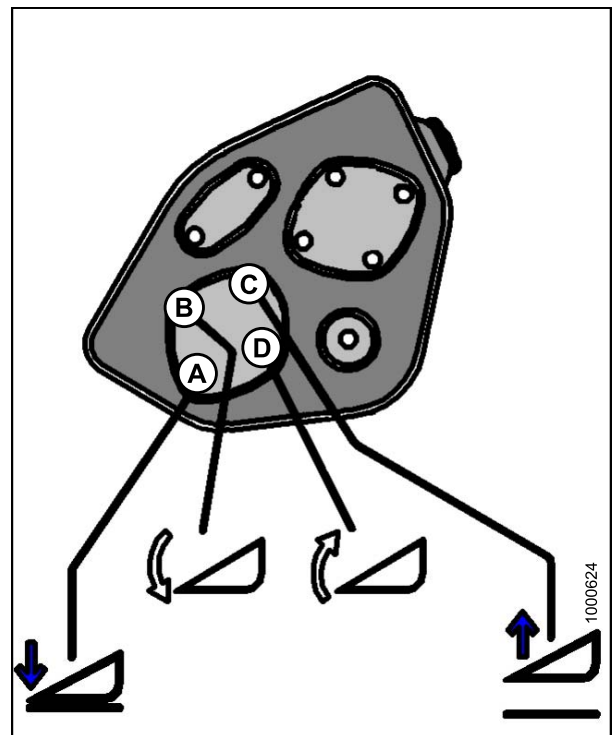

Figure 3.96: Header Height Controls on Ground Speed Lever

## OPERATOR'S STATION

### Calibrating the Header Tilt Sensor

#### NOTE:

- The header **MUST** be attached to the windrower to perform this procedure. The cab display module (CDM) automatically adjusts its programming for each header. Refer to [4.5 Attaching and Detaching Headers](#), page 214.

- The engine **MUST** be running to perform this procedure.

- Turn ignition key to RUN, or start the engine.
- Press PROGRAM (A) and SELECT (C) on cab display module (CDM) to enter Programming Mode.
  - WINDROWER SETUP? is displayed on the upper line.
- Press SELECT (C) until CALIBRATE SENSORS? is displayed on the upper line.
  - NO/YES is displayed on the lower line.

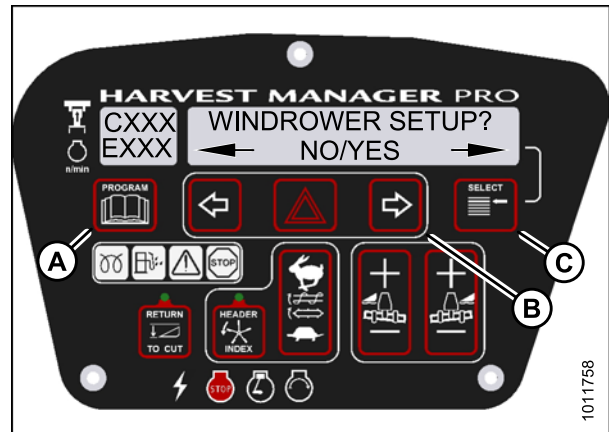

Figure 3.97: CDM Programming Buttons

- Press right (B) arrow to select Yes. Press SELECT (C).
  - TO CALIBRATE SELECT is displayed in upper line
- Press left (A) or right (B) arrow until HEADER TILT is displayed on the lower line. Press SELECT (C).
  - HDR TILT SENSOR CAL is displayed on the upper line.
  - EXTEND TILT TO START is displayed on the lower line.



Figure 3.98: Header Tilt

**CAUTION**

Check to be sure all bystanders have cleared the area.

6. Press and hold the HEADER TILT EXTEND (B) button on the ground speed lever (GSL).
  - CALIBRATING TILT is displayed on the upper line.
  - EXTEND TILT HOLD is displayed on the lower line.

**NOTE:**

The word HOLD will flash during calibration. HEADER TILT DONE will display on the lower line once calibration is complete.

7. Release the HEADER TILT EXTEND (B) button.
  - HEADER TILT SENSOR CAL is displayed on upper line.
  - PRESS RETRACT TILT is displayed on the lower line.

8. Press and hold HEADER TILT RETRACT (D) button on GSL.
  - CALIBRATING TILT is displayed on the upper line.
  - RETRACT TILT HOLD is displayed on the lower line.

**NOTE:**

The word HOLD will flash during calibration. HEADER TILT COMPLETE will display on the lower line once calibration is complete.

9. Release HEADER TILT RETRACT (D) button.
  - TO CALIBRATE SELECT is displayed on the upper line.
  - HEADER TILT is displayed on the lower line.
10. Press right arrow to select next header sensor calibration or STOP & EXIT. Press SELECT. Refer to [Calibrating the Header Height Sensor, page 99](#) or [Calibrating the Header Float Sensors, page 104](#).
11. Press PROGRAM to exit Programming Mode.

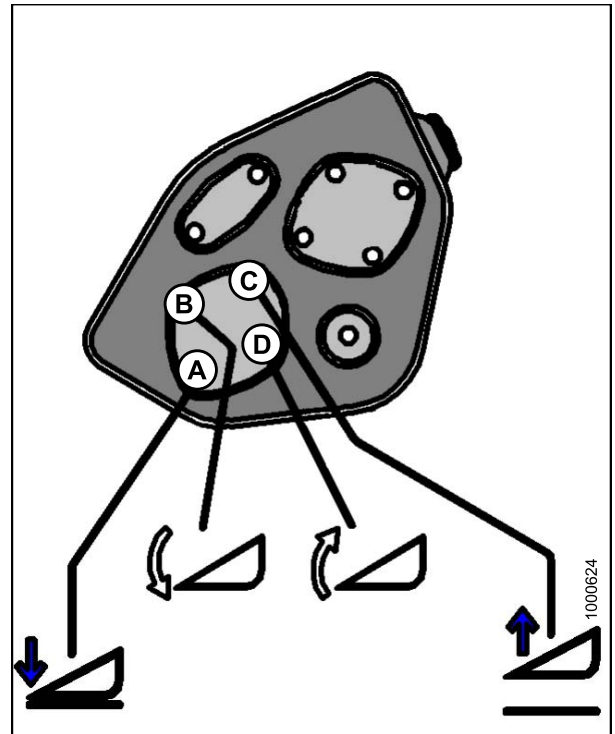

Figure 3.99: Header Tilt Controls on Ground Speed Lever

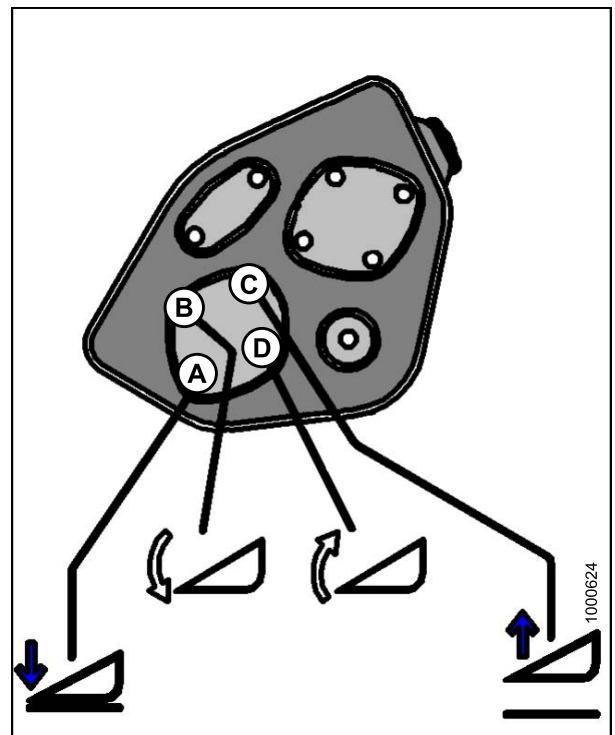

Figure 3.100: Header Tilt Controls on Ground Speed Lever

## OPERATOR'S STATION

### Calibrating the Header Float Sensors

#### NOTE:

- The header **MUST** be attached to the windrower to perform this procedure. The cab display module (CDM) automatically adjusts its programming for each header. For more information, refer to [4.5 Attaching and Detaching Headers, page 214](#).
- The Operator can use the left or right FLOAT buttons on the cab display module (CDM) to perform this procedure.

1. Turn ignition key to RUN, or start the engine.
2. Press PROGRAM (A) and SELECT (C) on cab display module (CDM) to enter Programming Mode.
  - WINDROWER SETUP? is displayed on the upper line.
3. Press SELECT (C) until CALIBRATE SENSORS? is displayed on the upper line.
  - NO/YES is displayed on the lower line.

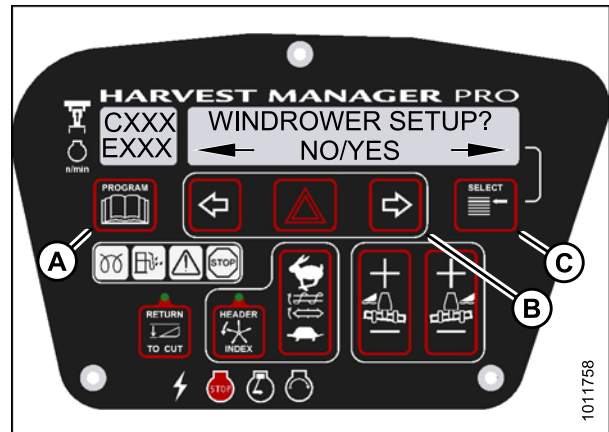

Figure 3.101: CDM Programming Buttons

4. Press right (B) arrow to select Yes. Press SELECT (C).
  - TO CALIBRATE SELECT is displayed in upper line.
5. Press left (A) or right (B) arrow until HEADER FLOAT is displayed on the lower line. Press SELECT (C).
  - CALIBRATING FLOAT is displayed on the upper line.
  - PRESS FLOAT + TO START is displayed on the lower line.

#### CAUTION

Check to be sure all bystanders have cleared the area.

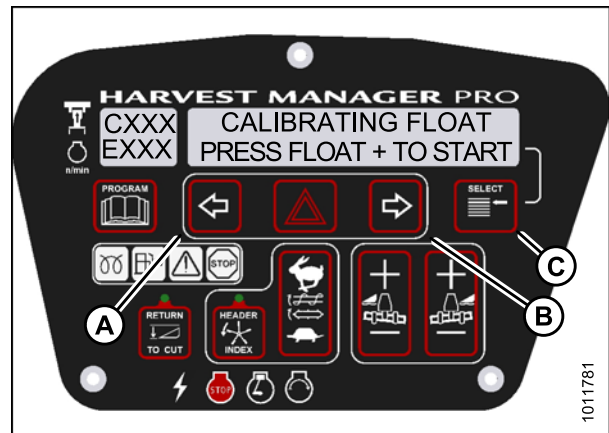

Figure 3.102: Header Float

## OPERATOR'S STATION

6. Press and hold FLOAT + button (A) on the CDM.
  - CALIBRATING FLOAT is displayed on the upper line.
  - FLOAT ( + ) HOLD is displayed on the lower line.

**NOTE:**

The word HOLD will flash during calibration.  
 FLOAT (+) DONE will display on the lower line once calibration is complete.

7. Release the FLOAT + button (A).
  - CALIBRATING FLOAT is displayed on the upper line.
  - FLOAT ( - ) HOLD is displayed on the lower line.

8. Press and hold FLOAT - button (A) on CDM.
  - CALIBRATING FLOAT is displayed on the upper line.
  - FLOAT ( - ) HOLD is displayed on the lower line.

**NOTE:**

The word HOLD will flash during calibration.  
 HDR FLOAT COMPLETE will display on the lower line once calibration is complete.

9. Release FLOAT - button (A).
  - TO CALIBRATE SELECT is displayed on the upper line.
  - HEADER FLOAT is displayed on the lower line.

10. Press right arrow to select next header sensor calibration or STOP & EXIT. Press SELECT  
 Refer to [Calibrating the Header Height Sensor, page 99](#) or [Calibrating the Header Tilt Sensor, page 102](#).

11. Press PROGRAM to exit Programming Mode.



**Figure 3.103: Positive Header Float**



**Figure 3.104: Negative Header Float**

### 3.19.9 Programming the Windrower

The windrower can be programmed to meet changing crop conditions, activate newly added options, indicate a change of header type, or increase the comfort level of the Operator.

#### Activating the Hydraulic Center-Link

1. Turn ignition key to RUN, or start the engine.
2. Press PROGRAM (A) and SELECT (C) on cab display module (CDM) to enter Programming Mode.
  - WINDROWER SETUP? is displayed on the upper line.
  - NO/YES is displayed on the lower line.
3. Press right (B) arrow to select YES. Press SELECT (C).
  - SET KNIFE SPEED? is displayed on the upper line.

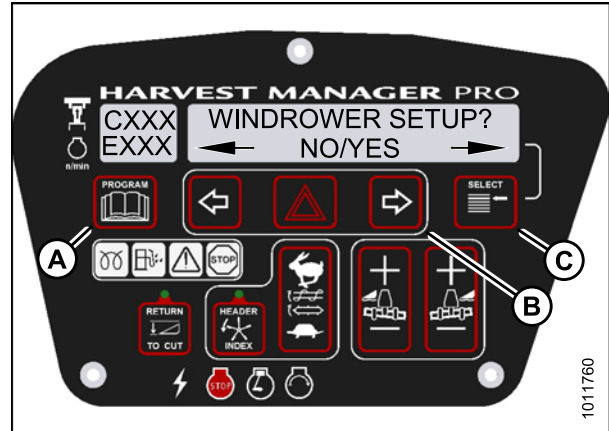

Figure 3.105: CDM Programming Buttons

4. Press SELECT (C) until TILT CYL INSTALLED? is displayed on the upper line.
  - NO/YES is displayed on the lower line.
5. Press right (B) arrow to select YES. Press SELECT (C).
6. Press PROGRAM (A) to exit Programming Mode or press SELECT (C) to proceed to next WINDROWER SETUP action.

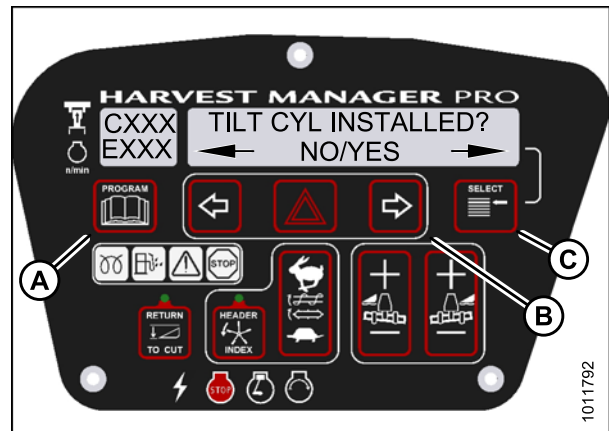

Figure 3.106: Hydraulic Center-Link

#### Activating the Rotary Header Drive Hydraulics

**NOTE:**

This procedure requires installation of the optional Rotary Header Drive Hydraulics (MD #B5510). For more information, refer to [6.2.9 Rotary Header Drive Hydraulics \(13-foot\), page 421](#).

## OPERATOR'S STATION

1. Turn ignition key to RUN, or start the engine.
2. Press PROGRAM (A) and SELECT (C) on cab display module (CDM) to enter Programming Mode.
  - WINDROWER SETUP? is displayed on the upper line.
  - NO/YES is displayed on the lower line.
3. Press right (B) arrow to select YES. Press SELECT (C).
  - SET KNIFE SPEED? is displayed on the upper line.

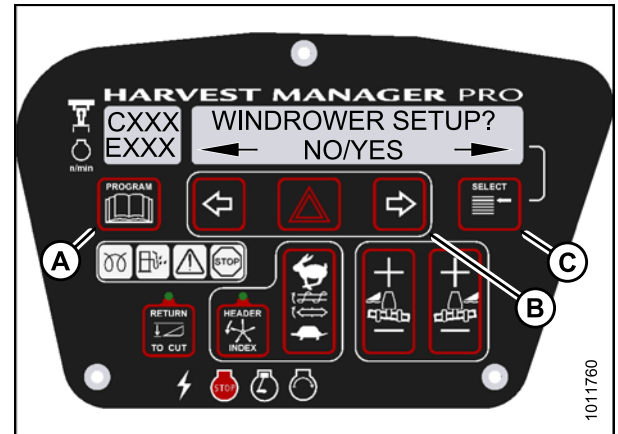

Figure 3.107: CDM Programming Buttons

4. Press SELECT (D) until DISC BLK INSTALLED? is displayed on the upper line.
  - NO/YES is displayed on the lower line.
5. Press right (C) arrow to select YES. Press SELECT (D).
6. Press PROGRAM (A) to exit Programming Mode or press SELECT (D) to proceed to next WINDROWER SETUP action.

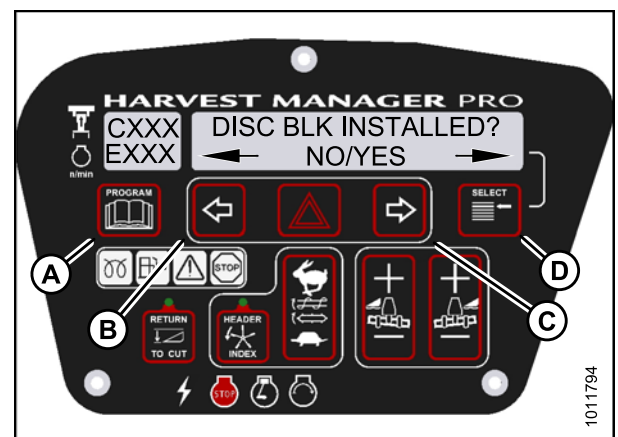

Figure 3.108: Rotary Disc Hydraulics

### Setting the Header Knife Speed

#### NOTE:

- The header **MUST** be attached to the windrower to perform this procedure. The cab display module (CDM) automatically adjusts its programming for each header. For more information, refer to [4.5 Attaching and Detaching Headers, page 214](#).

1. Turn ignition key to RUN, or start the engine.
2. Press PROGRAM (A) and SELECT (C) on cab display module (CDM) to enter Programming Mode.
  - WINDROWER SETUP? is displayed on the upper line.
  - NO/YES is displayed on the lower line.
3. Press right (B) arrow to select YES. Press SELECT (C).
  - SET KNIFE SPEED? is displayed.
  - The current knife speed is displayed on the lower line.

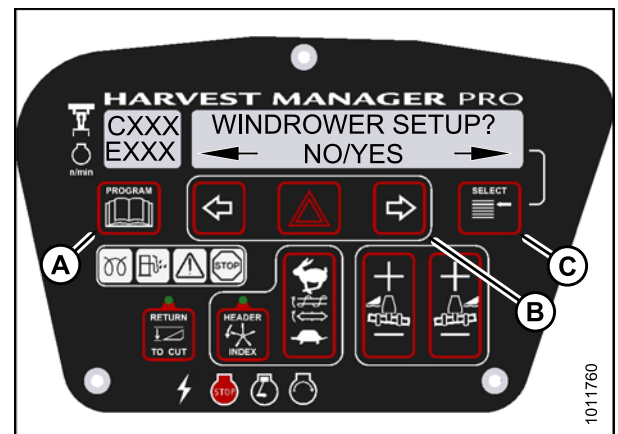

Figure 3.109: CDM Programming Buttons

## OPERATOR'S STATION

4. Press left (B) or right (C) arrows to select knife speed. Press SELECT (D).
5. Press PROGRAM (A) to exit Programming Mode or press SELECT (D) to proceed to next WINDROWER SETUP action.

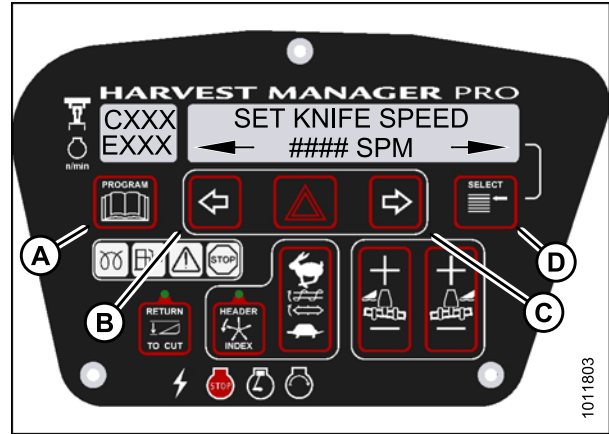

Figure 3.110: Knife Speed

### Setting the Knife Overload Speed

#### NOTE:

- The header **MUST** be attached to the windrower to perform this procedure. The cab display module (CDM) automatically adjusts its programming for each header. For more information, refer to [4.5 Attaching and Detaching Headers, page 214](#).
- The recommended knife overload speed is 75% of knife speed.

1. Turn ignition key to RUN, or start the engine.
2. Press PROGRAM (A) and SELECT (C) on cab display module (CDM) to enter Programming Mode.
  - WINDROWER SETUP? is displayed on the upper line.
  - NO/YES is displayed on the lower line.
3. Press right (B) arrow to select YES. Press SELECT (C).
  - SET KNIFE SPEED? is displayed.

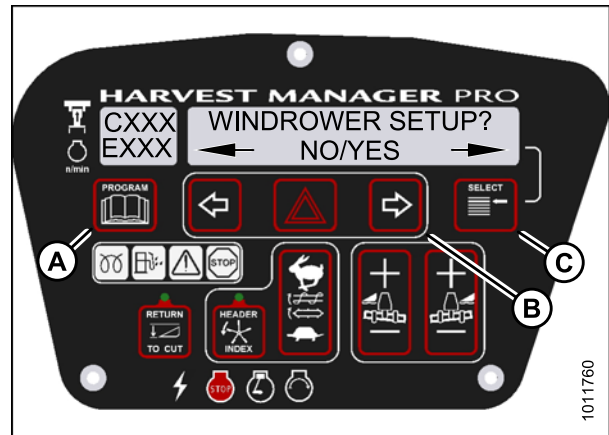

Figure 3.111: CDM Programming Buttons



## OPERATOR'S STATION

- Press SELECT (D) until KNIFE OVERLOAD SPD? is displayed on the upper line.

- Current overload speed is displayed on the lower line.

**NOTE:**

Default setting is -300 spm. Range is -500 to -100 spm.

- Press left (B) or right (C) arrows to set knife overload speed. Press SELECT (D).
- Press PROGRAM (A) to exit Programming Mode or press SELECT (D) to proceed to next WINDROWER SETUP action.

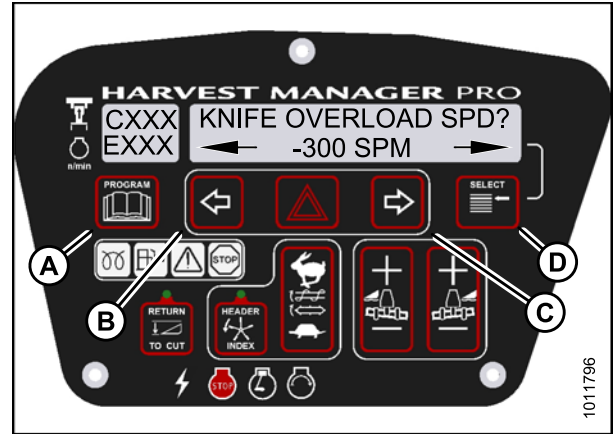

Figure 3.112: Knife Overload Speed

### Setting the Rotary Disc Overload Speed

**NOTE:**

- The header **MUST** be attached to the windrower to perform this procedure. The cab display module (CDM) automatically adjusts its programming for each header. For more information, refer to [4.5 Attaching and Detaching Headers, page 214](#).
- The recommended disc overload speed is 75% of disc speed. For more information refer to the rotary disc header operator's manual to determine proper overload speed.

- Turn ignition key to RUN, or start the engine.
- Press PROGRAM (A) and SELECT (C) on cab display module (CDM) to enter Programming Mode.
  - WINDROWER SETUP? is displayed on the upper line.
  - NO/YES is displayed on the lower line.
- Press right (B) arrow to select YES. Press SELECT (C).
  - SET KNIFE SPEED? is displayed.

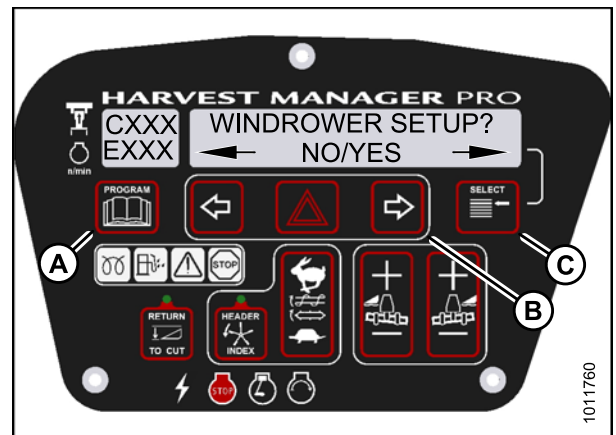

Figure 3.113: CDM Programming Buttons

## OPERATOR'S STATION

4. Press SELECT (D) until DISK OVERLOAD SPD? is displayed on the upper line.

- The current overload speed is displayed on the lower line.

**NOTE:**

Default setting is -300 rpm. Range is -500 to -100 rpm.

5. Press left (B) or right (C) arrows to set disc overload speed. Press SELECT (D).
6. Press PROGRAM (A) to exit Programming Mode or press SELECT (D) to proceed to next WINDROWER SETUP action.

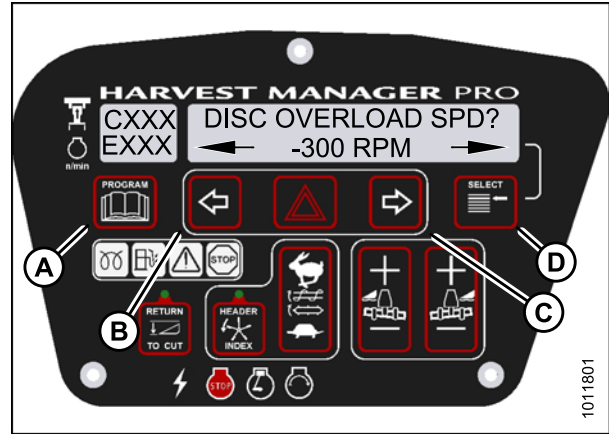

Figure 3.114: Disc Overload Speed

### Setting the Hydraulic Overload Pressure

**NOTE:**

- This procedure requires installation of the optional pressure sensor (MD #B5574). For overload pressure values, refer to pressure sensor installation instructions (MD #169031).
- To enable sensor, refer to [Switching the Installed Header Sensors On or Off, page 133](#).

1. Turn ignition key to RUN, or start the engine.
2. Press PROGRAM (A) and SELECT (C) on cab display module (CDM) to enter Programming Mode.
  - WINDROWER SETUP? is displayed on the upper line.
  - NO/YES is displayed on the lower line.
3. Press right (B) arrow to select YES. Press SELECT (C).
  - SET KNIFE SPEED? is displayed.

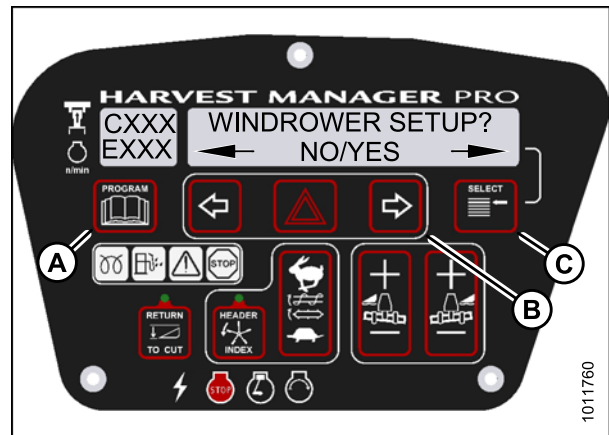

Figure 3.115: CDM Programming Buttons

## OPERATOR'S STATION

4. Press SELECT (D) until OVERLOAD PRESSURE? is displayed on the upper line.

- The current overload pressure is displayed on lower line.

**NOTE:**

Pressure range is 2500–5000 psi (17,237–34,474 kPa).

5. Press left (B) or right (C) arrows to set hydraulic overload pressure. Press SELECT (D).
6. Press PROGRAM (A) to exit Programming Mode or press SELECT (D) to proceed to next WINDROWER SETUP action.

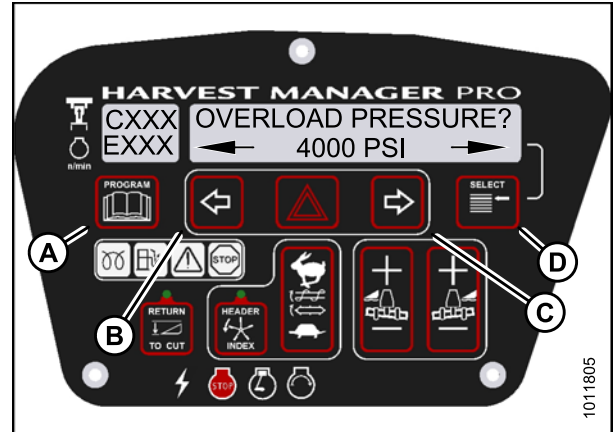

Figure 3.116: Hydraulic Overload Pressure

### Setting the Header Index Mode

Header Index feature is not applicable to rotary headers.

**NOTE:**

The header **MUST** be attached to the windrower to perform this procedure. The cab display module (CDM) automatically adjusts its programming for each header. For more information, refer to [4.5 Attaching and Detaching Headers, page 214](#).

1. Turn ignition key to RUN, or start the engine.
2. Press PROGRAM (A) and SELECT (C) on cab display module (CDM) to enter Programming Mode.
  - WINDROWER SETUP? is displayed on the upper line.
  - NO/YES is displayed on the lower line.
3. Press right (B) arrow to select YES. Press SELECT (C).
  - SET KNIFE SPEED? is displayed on the upper line.

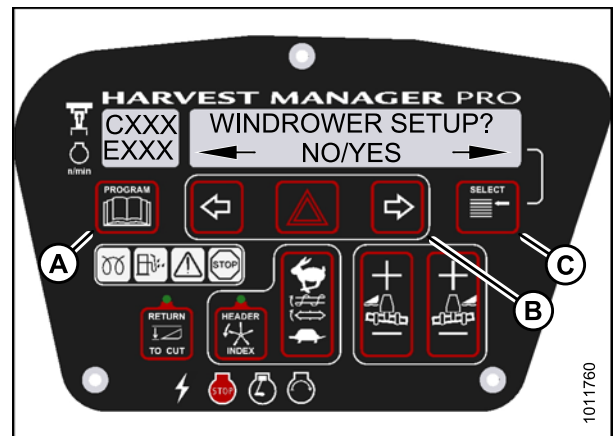

Figure 3.117: CDM Programming Buttons

## OPERATOR'S STATION

4. Press SELECT (D) until HEADER INDEX MODE? is displayed on the upper line.
  - REEL & CONVEYOR or REEL ONLY is displayed on the lower line.
5. Press left (B) or right (C) arrows to set header index mode. Press SELECT (D).
6. Press PROGRAM (A) to exit Programming Mode or press SELECT (D) to proceed to next WINDROWER SETUP action.

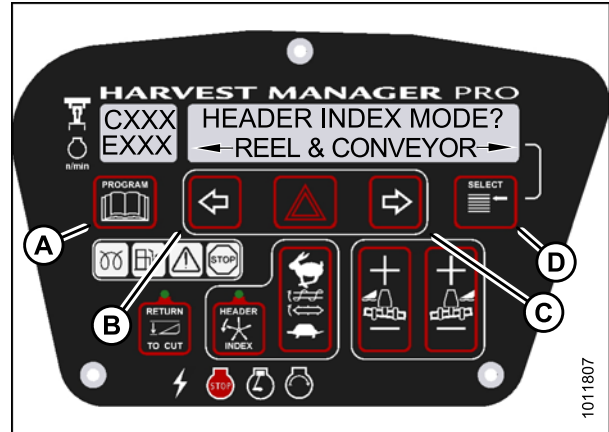

Figure 3.118: Header Index Mode

### Setting the Return to Cut Mode

#### NOTE:

The header **MUST** be attached to the windrower to perform this procedure. The cab display module (CDM) automatically adjusts its programming for each header. For more information, refer to [4.5 Attaching and Detaching Headers, page 214](#).

1. Turn ignition key to RUN, or start the engine.
2. Press PROGRAM (A) and SELECT (C) on cab display module (CDM) to enter Programming Mode.
  - WINDROWER SETUP? is displayed on the upper line.
  - NO/YES is displayed on the lower line.
3. Press right (B) arrow to select YES. Press SELECT (C).
  - SET KNIFE SPEED? is displayed.

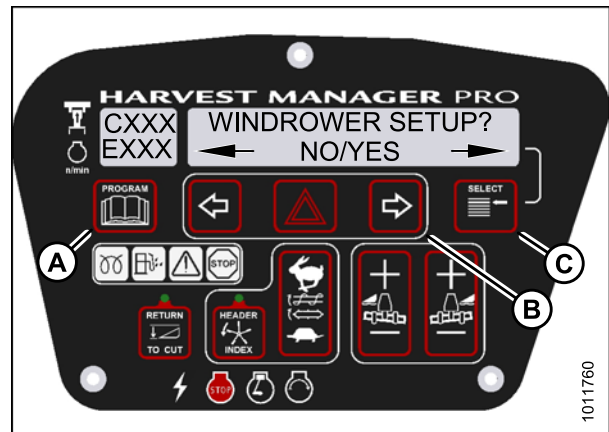

Figure 3.119: CDM Programming Buttons

4. Press SELECT (D) until RETURN TO CUT MODE? is displayed on the upper line.
  - HEIGHT & TILT or HEIGHT ONLY will be displayed on the lower line.
5. Press left (B) or right (C) arrows to select return to cut mode. Press SELECT (D).
6. Press PROGRAM (A) to exit Programming Mode or press SELECT (D) to proceed to next WINDROWER SETUP action.

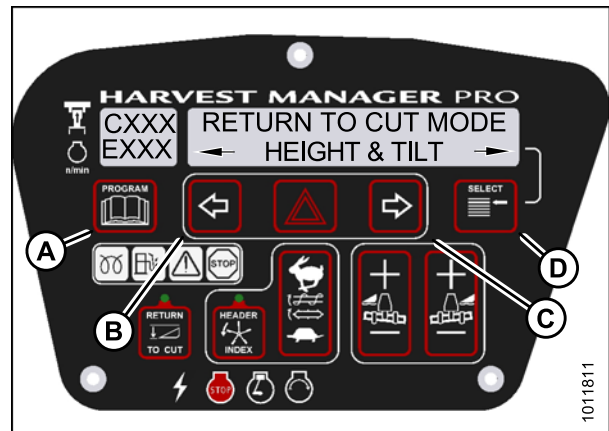

Figure 3.120: Return to Cut Mode

## OPERATOR'S STATION

### Setting the Header Cut Width

#### NOTE:

- The header **MUST** be attached to the windrower to perform this procedure. The cab display module (CDM) automatically adjusts its programming for each header. For more information, refer to [4.5 Attaching and Detaching Headers, page 214](#).
- Header cut width is less than actual header width to accurately measure number of acres cut.
- The headers sends an electrical signal to the windrower to produce a header ID; however, the cut width will always default to the smallest header size available for each header type. For example, A-Series Auger Headers comes in 14-, 16-, and 18-foot sizes, but the cut width will automatically default to the smallest 14-foot size and will need to be changed according to your specific header's size.

1. Turn ignition key to RUN, or start the engine.
2. Press PROGRAM (A) and SELECT (C) on cab display module (CDM) to enter Programming Mode.
  - WINDROWER SETUP? is displayed on the upper line.
  - NO/YES is displayed on the lower line.
3. Press right (B) arrow to select YES. Press SELECT (C).
  - SET KNIFE SPEED? is displayed.

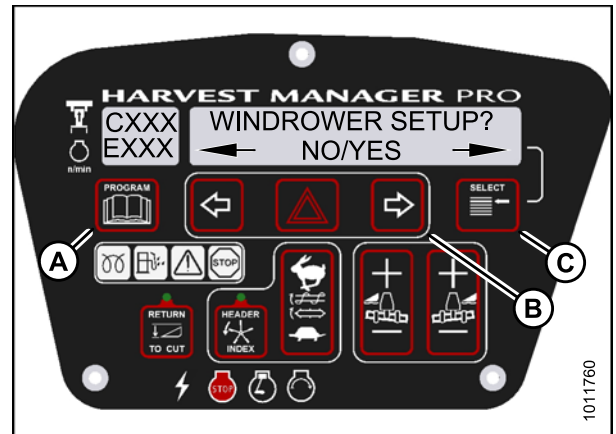

Figure 3.121: CDM Programming Buttons

4. Press SELECT (D) until HDR CUT WIDTH? #### is displayed on the upper line.
  - Previous cutting width is displayed on the lower line.
5. Press left (B) or right (C) arrows to change the headers cut width. Press SELECT (D).
6. Press PROGRAM (A) to exit Programming Mode or press SELECT (D) to proceed to next WINDROWER SETUP action.

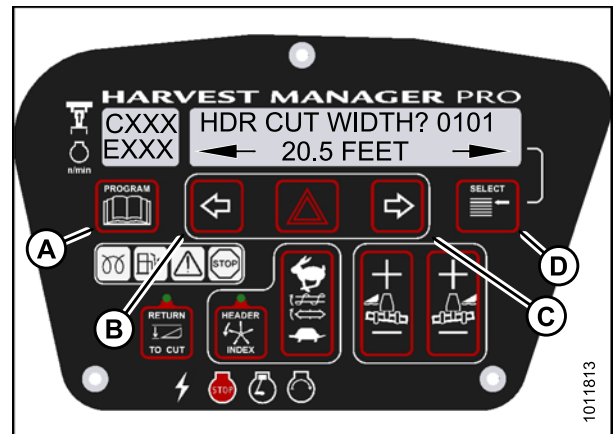

Figure 3.122: Header Cut Width

### Activating the Double Windrow Attachment (DWA)

#### NOTE:

- Follow this procedure if installing the DWA; however, refer to the DWA manual if you require additional installation instructions.
- Follow this procedure if installing a drive manifold (MD #139508).

## OPERATOR'S STATION

1. Turn ignition key to RUN, or start the engine.
2. Press PROGRAM (A) and SELECT (C) on cab display module (CDM) to enter Programming Mode.
  - WINDROWER SETUP? is displayed on the upper line.
  - NO/YES is displayed on the lower line.
3. Press right (B) arrow to select YES. Press SELECT (C).
  - SET KNIFE SPEED? is displayed on the upper line.

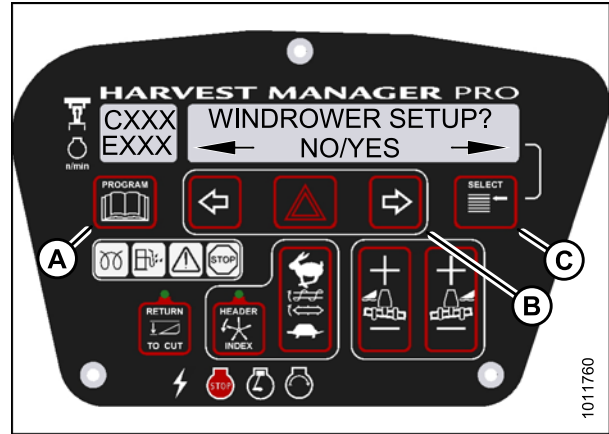

Figure 3.123: CDM Programming Buttons

4. Press SELECT (B) until DWA INSTALLED? is displayed on the upper line.
  - NO/YES is displayed on the lower line.
5. Press right (A) arrow to select YES. Press SELECT (B).

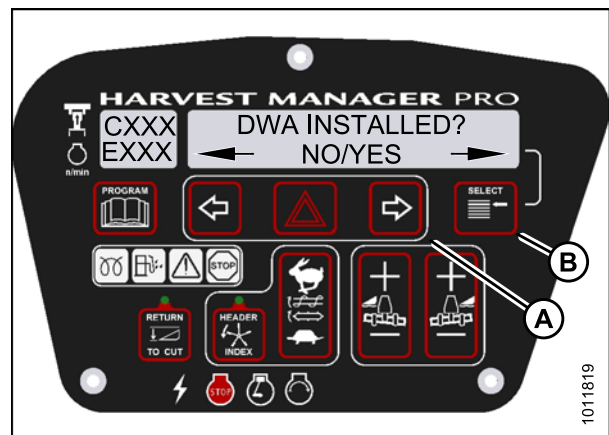

Figure 3.124: DWA Controls

6. SWAP DWA CONTROLS? is displayed on the upper line.
  - NO/YES is displayed on the lower line.

**NOTE:**

This step swaps the DWA controls from the console switch to the ground speed lever (GSL) reel fore-aft buttons.

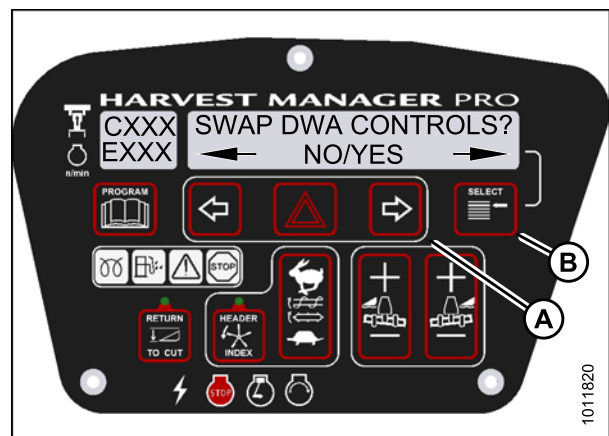

Figure 3.125: DWA Controls

## OPERATOR'S STATION

- Press right (C) arrow to select YES. Press SELECT (D).

  - DWA AUTO UP/DOWN? is displayed on the upper line.
  - NO/YES is displayed on the lower line.

**NOTE:**

If the Operator selects YES, the DWA Auto-Up function will be activated by the GSL Reel Fore-Aft button.

- Press right (C) arrow to select YES. Press SELECT (D).
- Press PROGRAM to exit Programming Mode or press SELECT to proceed to next WINDROWER SETUP action.

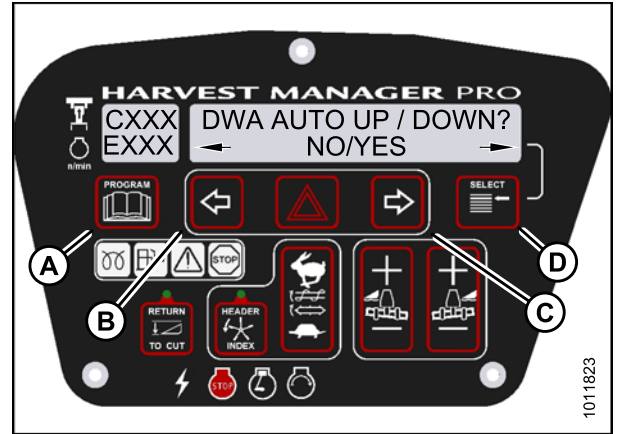

Figure 3.126: DWA Auto Up/Down

### Setting the Auto Raise Height

For more information on the Auto Raise Height feature, refer to [Auto Raise Height, page 210](#).

**NOTE:**

The header **MUST** be attached to the windrower to perform this procedure. The cab display module (CDM) automatically adjusts its programming for each header.

- Turn ignition key to RUN, or start the engine.
- Press PROGRAM (A) and SELECT (C) on cab display module (CDM) to enter Programming Mode.
  - WINDROWER SETUP? is displayed on the upper line.
  - NO/YES is displayed on the lower line.
- Press right (B) arrow to select YES. Press SELECT (C).
  - SET KNIFE SPEED? is displayed on the upper line.

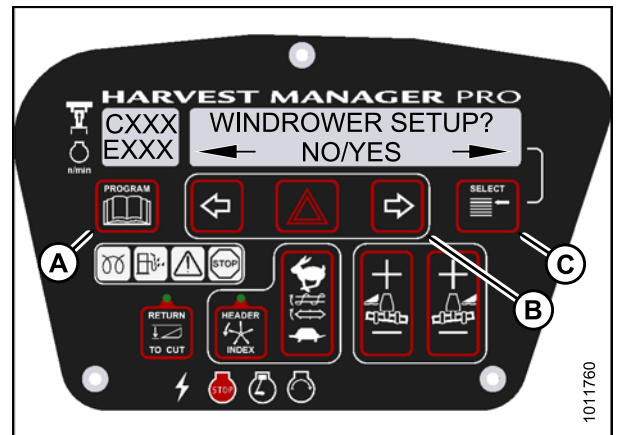

Figure 3.127: CDM Programming Buttons

## OPERATOR'S STATION

4. Press SELECT (D) until AUTO RAISE HEIGHT? is displayed on the upper line.

- Last measurement is displayed on the lower line.

### NOTE:

The auto raise height ranges from 4.0 (minimum) to 9.5 (maximum), in 0.5 increments. A setting of 10 disables the auto raise function.

5. Press left (B) arrow or right (C) arrow to change auto-raise height.
6. Press PROGRAM (A) to exit Programming Mode or press SELECT (D) to proceed to next WINDROWER SETUP action.



Figure 3.128: Auto Raise Height

### Activating the Hay Conditioner

### NOTE:

- This procedure is for draper headers only.
- The header **MUST** be attached to the windrower to perform this procedure. The cab display module (CDM) automatically adjusts its programming for each header. For more information, refer to [4.5 Attaching and Detaching Headers, page 214](#).

1. Turn ignition key to RUN, or start the engine.
2. Press PROGRAM (A) and SELECT (C) on cab display module (CDM) to enter Programming Mode.
  - WINDROWER SETUP? is displayed on the upper line.
  - NO/YES is displayed on the lower line.
3. Press right (B) arrow to select YES. Press SELECT (C).
  - SET KNIFE SPEED? is displayed on the upper line.

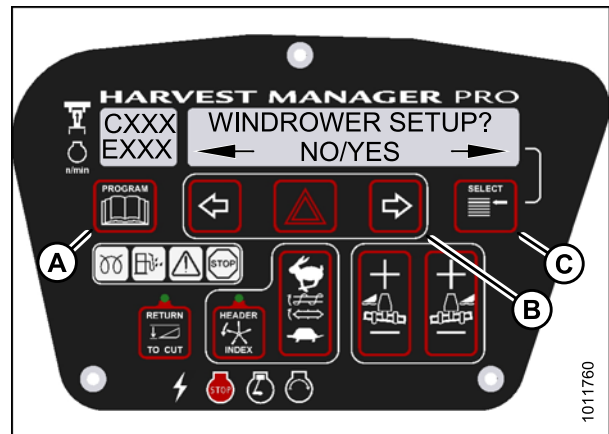

Figure 3.129: CDM Programming Buttons



## OPERATOR'S STATION

4. Press SELECT (C) until HAY CONDITIONER? is displayed on the upper line.
  - NO/YES is displayed on the lower line.
5. Press right (B) arrow to select YES. Press SELECT (C).
6. Press PROGRAM (A) to exit Programming Mode or press SELECT (C) to proceed to next WINDROWER SETUP action.

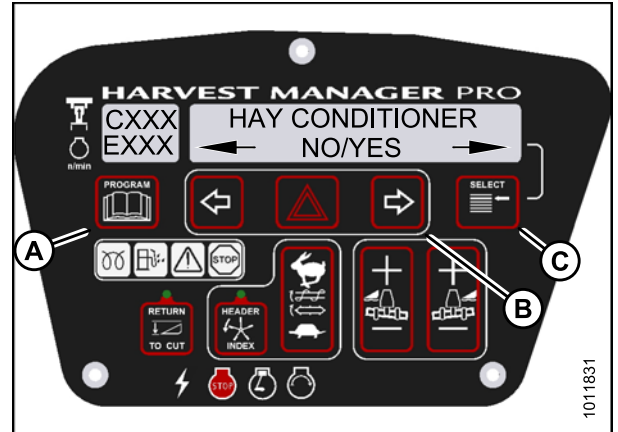

Figure 3.130: Hay Conditioner

### Displaying Reel Speed

#### NOTE:

- This procedure is for draper and auger headers. It does not apply to rotary disc headers.
- The header **MUST** be attached to the windrower to perform this procedure. The cab display module (CDM) automatically adjusts its programming for each header. For more information, refer to [4.5 Attaching and Detaching Headers, page 214](#).

1. Turn ignition key to RUN, or start the engine.
2. Press PROGRAM (A) and SELECT (C) on CDM to enter Programming Mode.
  - WINDROWER SETUP? is displayed on the upper line.
  - NO/YES is displayed on the lower line.
3. Press right (B) arrow to select YES. Press SELECT (C).
  - SET KNIFE SPEED? is displayed on the upper line.

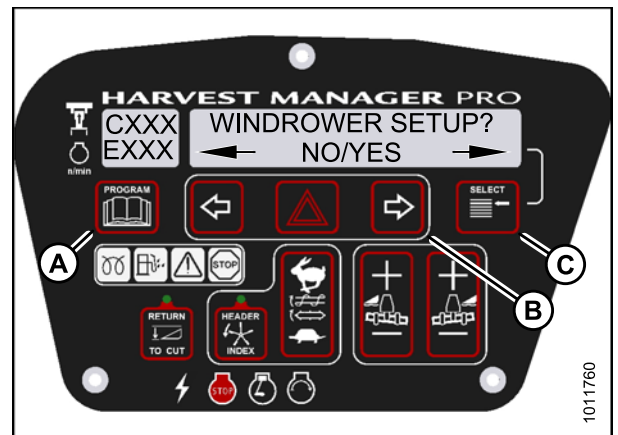

Figure 3.131: CDM Programming Buttons

## OPERATOR'S STATION

4. Press SELECT (D) until HEADER REEL SPEED? is displayed on the upper line.
  - RPM/MPH or RPM/KPH is displayed on the lower line.
5. Press left (B) or right (C) arrow to select either Imperial or Metric units. Press SELECT (D).
6. Press PROGRAM (A) to exit Programming Mode or press SELECT (D) to proceed to next WINDROWER SETUP action.



Figure 3.132: Reel Speed Display

### Setting the Windrower's Tire Size

1. Turn ignition key to RUN, or start the engine.
2. Press PROGRAM (A) and SELECT (C) on cab display module (CDM) to enter Programming Mode.
  - WINDROWER SETUP? is displayed on the upper line.
  - NO/YES is displayed on the lower line.
3. Press right (B) arrow to select YES. Press SELECT (C).
  - SET KNIFE SPEED? is displayed on the upper line.

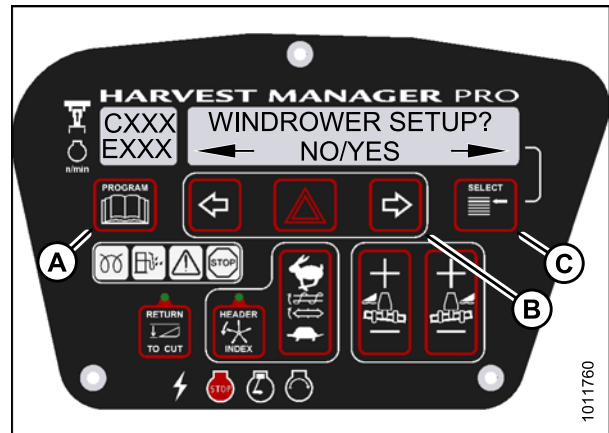

Figure 3.133: CDM Programming Buttons

4. Press SELECT (D) until SET TIRE SIZE? is displayed on the upper line.
  - Currently installed tire size is displayed on the lower line.

#### NOTE:

The following tire sizes are available:

- 18.4 x 26 TURF
- 18.4 x 26 BAR
- 23.1 x 26 TURF
- 600 – 65 R28

5. Press left (B) or right (C) arrow and select tire size. Press SELECT (D).
6. Press PROGRAM (A) to exit Programming Mode or press SELECT (D) to proceed to next WINDROWER SETUP action.

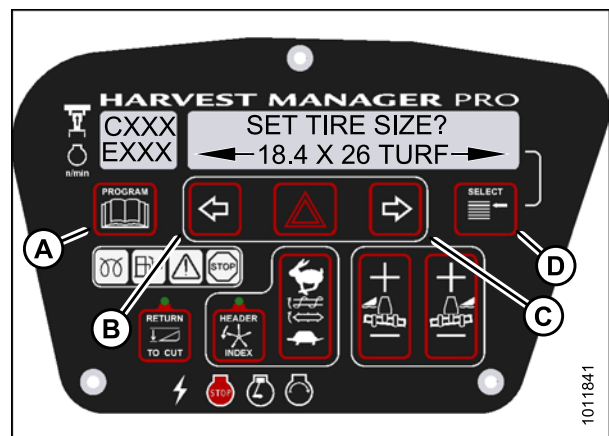

Figure 3.134: Tire Size

## OPERATOR'S STATION

### Setting the Engine Intermediate Speed Control (ISC) RPM

**NOTE:**

The ISC sets the engine speed when the header is engaged. For more information, refer to [Engine Intermediate Speed Control \(ISC\), page 166](#). The engine **MUST** be running to perform this procedure.

1. Turn ignition key to RUN, or start the engine.
2. Press PROGRAM (A) and SELECT (C) on cab display module (CDM) to enter Programming Mode.
  - WINDROWER SETUP? is displayed on the upper line.
  - NO/YES is displayed on the lower line.
3. Press right (B) arrow to select YES. Press SELECT (C).
  - SET KNIFE SPEED? is displayed on the upper line.

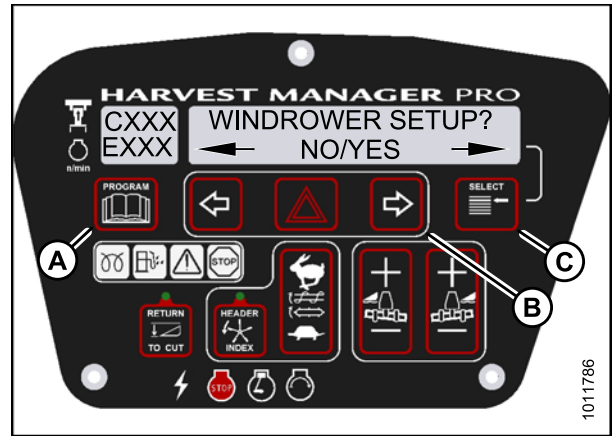

Figure 3.135: CDM Programming Buttons

4. Press SELECT (C) until SET ENGINE ISC RPM? is displayed on the upper line.
  - NO/YES is displayed on the lower line.
5. Press right (B) arrow to select YES. Press SELECT (C).
  - PRESS HAZARD TO SET is displayed on the upper line.
  - ISC RPM ##### is displayed on the lower line.

**NOTE:**

The previously selected ISC rpm will be flashing.

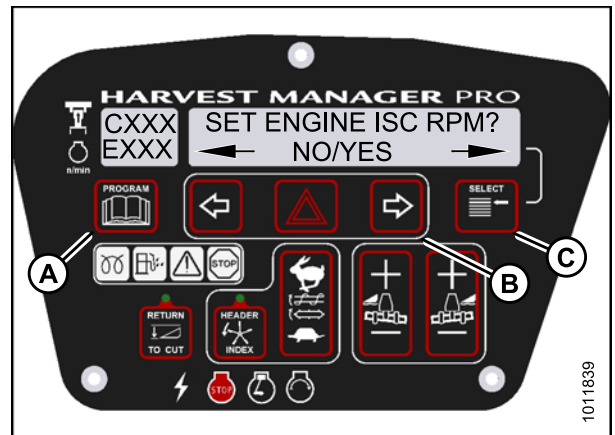

Figure 3.136: Engine ISC RPM

6. Press right (C) arrow to cycle between rpm options. Press HAZARD (B) to set.
7. Press Select (D).
  - EXIT ENGINE ISC? is displayed on the upper line.
  - NO/YES is displayed on the lower line.
8. Press right (C) arrow to select YES. Press SELECT (D).
9. Press PROGRAM (A) to exit Programming Mode.

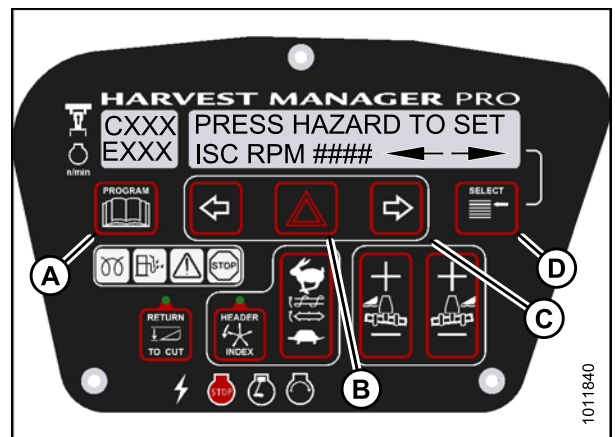

Figure 3.137: ISC RPM

## OPERATOR'S STATION

### Clearing Sub-Acres

1. With the key in the ON position, and the operator's station in cab forward mode, press SELECT until the cab display module (CDM) displays sub-acres on the bottom line. Then press and hold the PROGRAM (A) button on the CDM until the sub-acres are cleared.



Figure 3.138: Cab Display Module (CDM)

### 3.19.10 Activating Cab Display Lock Outs

You can lock some of the header functions controlled by the cab display module (CDM) to prevent accidental changes to header settings. You can use this feature to keep header settings constant when several different operators use the windrower.

**NOTE:**

FUNCTION LOCKED flashes on CDM when locked header function switch is pressed.

#### Activating Knife Speed Control Lock Out

**NOTE:**

The header **MUST** be attached to the windrower to perform this procedure. The cab display module (CDM) automatically adjusts its programming for each header. For more information, refer to [4.5 Attaching and Detaching Headers, page 214](#).

1. Turn ignition key to RUN, or start the engine.
2. Press PROGRAM (A) and SELECT (C) on cab display module (CDM) to enter Programming Mode.
  - WINDROWER SETUP? is displayed on the upper line.
  - NO/YES is displayed on the lower line.
3. Press right (B) arrow to select YES. Press SELECT (C).
  - SET KNIFE SPEED? is displayed on the upper line.

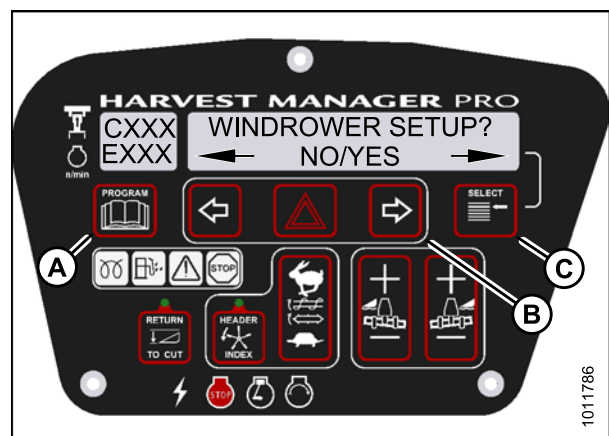

Figure 3.139: CDM Programming Buttons

## OPERATOR'S STATION

4. Press SELECT (B) until SET CONTROL LOCKS? is displayed on the upper line.
  - NO/YES is displayed on the lower line.
5. Press right (A) arrow to select YES. Press SELECT (B).

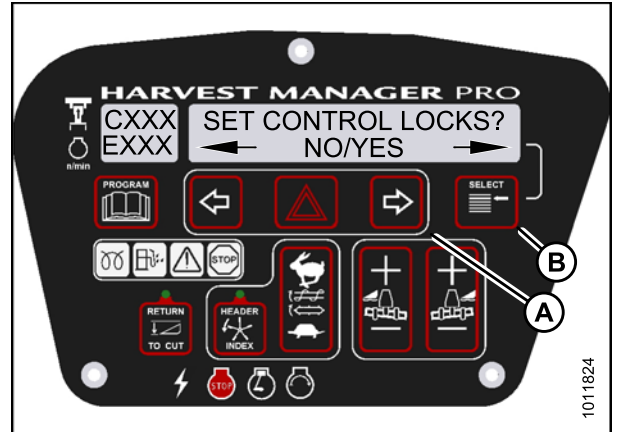

Figure 3.140: Control Locks

6. Press SELECT (D) until KNIFE SPEED is displayed on the upper line.
  - ENABLED/LOCKED is displayed on the lower line.
7. Press left arrow (B) to enable KNIFE SPEED control switch, or press right arrow (C) to lock KNIFE SPEED control switch.
8. Press PROGRAM (A) to exit Programming Mode or press SELECT (D) to proceed to next WINDROWER SETUP action.

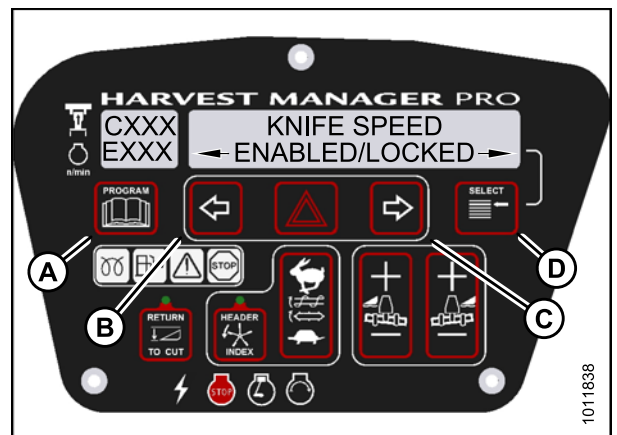

Figure 3.141: Knife Speed Control Lock

### Activating Rotary Disc Speed Control Lock Out

#### NOTE:

- This procedure is for rotary disc headers only.
- The header **MUST** be attached to the windrower to perform this procedure. The cab display module (CDM) automatically adjusts its programming for each header. For more information, refer to [4.5 Attaching and Detaching Headers, page 214](#).

## OPERATOR'S STATION

1. Turn ignition key to RUN, or start the engine.
2. Press PROGRAM (A) and SELECT (C) on cab display module (CDM) to enter Programming Mode.
  - WINDROWER SETUP? is displayed on the upper line.
  - NO/YES is displayed on the lower line.
3. Press right (B) arrow to select YES. Press SELECT (C).
  - SET KNIFE SPEED? is displayed on the upper line.

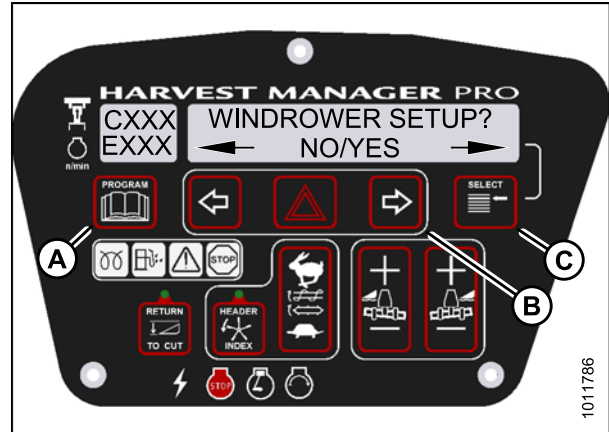

Figure 3.142: CDM Programming Buttons

4. Press SELECT (B) until SET CONTROL LOCKS? is displayed on the upper line.
  - NO/YES is displayed on the lower line.
5. Press right (A) arrow to select YES. Press SELECT (B).



Figure 3.143: Control Locks

6. Press SELECT (D) until DISK SPEED is displayed on the upper line.
  - ENABLED/LOCKED is displayed on the lower line.
7. Press left arrow (B) to enable DISK SPEED control switch, or press right arrow (C) to lock DISK SPEED control switch.
8. Press PROGRAM (A) to exit Programming Mode or press SELECT (D) to proceed to next WINDROWER SETUP action.

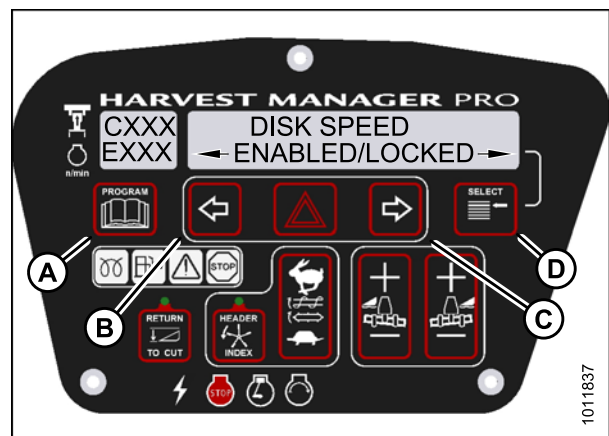

Figure 3.144: Disc Speed Control Lock

### Activating the Header Float Control Lock Out

#### NOTE:

The header **MUST** be attached to the windrower to perform this procedure. The cab display module (CDM) automatically adjusts its programming for each header. For more information, refer to [4.5 Attaching and Detaching Headers, page 214](#).

## OPERATOR'S STATION

1. Turn ignition key to RUN, or start the engine.
2. Press PROGRAM (A) and SELECT (C) on cab display module (CDM) to enter Programming Mode.
  - WINDROWER SETUP? is displayed on the upper line.
  - NO/YES is displayed on the lower line.
3. Press right (B) arrow to select YES. Press SELECT (C).
  - SET KNIFE SPEED? is displayed on the upper line.

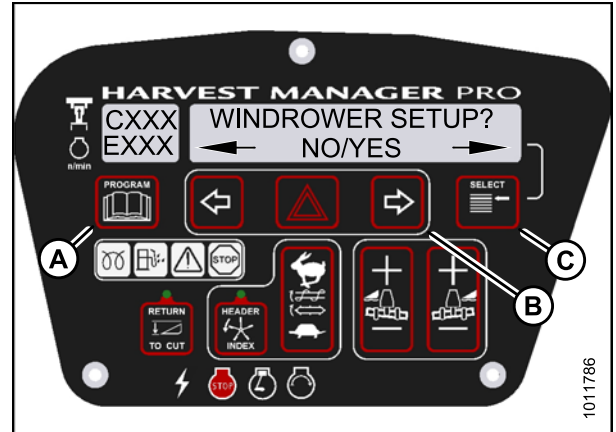

Figure 3.145: CDM Programming Buttons

4. Press SELECT (B) until SET CONTROL LOCKS? is displayed on the upper line.
  - NO/YES is displayed on the lower line.
5. Press right (A) arrow to select YES. Press SELECT (B).

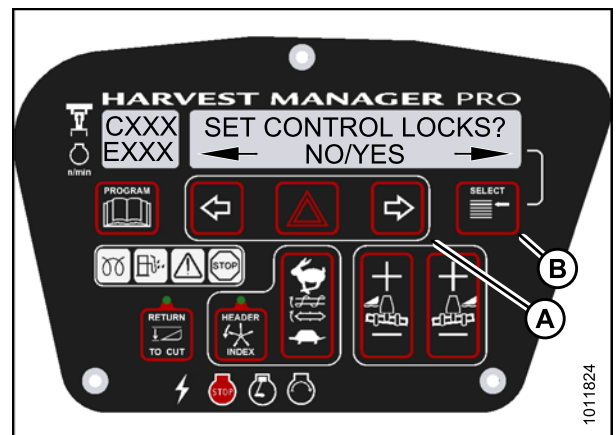

Figure 3.146: Control Locks

6. Press SELECT (D) until HEADER FLOAT is displayed on the upper line.
  - ENABLED/LOCKED is displayed on the lower line.
7. Press left arrow (B) to enable HEADER FLOAT control switch, or press right arrow (C) to lock HEADER FLOAT control switch.
8. Press PROGRAM (A) to exit Programming Mode or press SELECT (D) to proceed to next WINDROWER SETUP action.

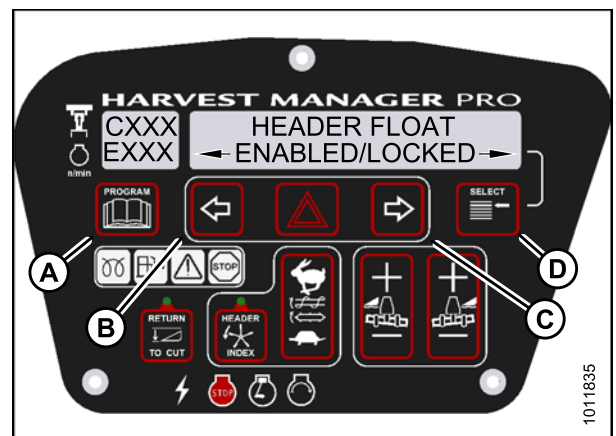

Figure 3.147: Header Float Control Lock

## OPERATOR'S STATION

### Activating the Draper Speed Control Lock Out

#### NOTE:

- This procedure is for draper headers only.
- The header **MUST** be attached to the windrower to perform this procedure. The cab display module (CDM) automatically adjusts its programming for each header. For more information, refer to [4.5 Attaching and Detaching Headers, page 214](#).

1. Turn ignition key to RUN, or start the engine.
2. Press PROGRAM (A) and SELECT (C) on cab display module (CDM) to enter Programming Mode.
  - WINDROWER SETUP? is displayed on the upper line.
  - NO/YES is displayed on the lower line.
3. Press right (B) arrow to select YES. Press SELECT (C).
  - SET KNIFE SPEED? is displayed on the upper line.

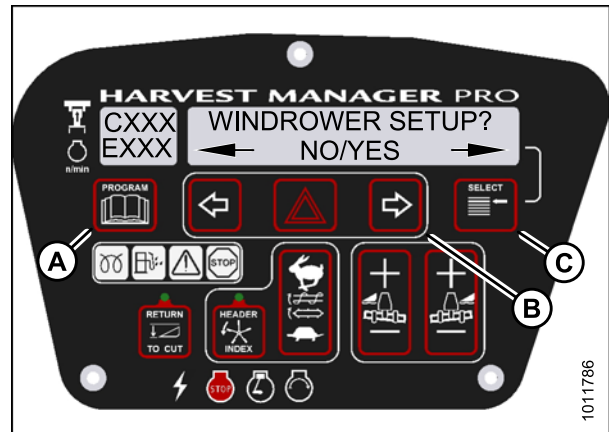

Figure 3.148: CDM Programming Buttons

4. Press SELECT (B) until SET CONTROL LOCKS? is displayed on the upper line.
  - NO/YES is displayed on the lower line.
5. Press right (A) arrow to select YES. Press SELECT (B).

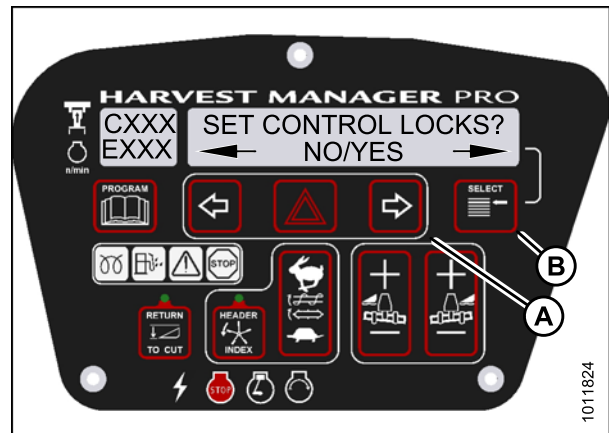

Figure 3.149: Control Locks



## OPERATOR'S STATION

6. Press SELECT (D) until DRAPER SPEED is displayed on the upper line.
  - ENABLED/LOCKED is displayed on the lower line.
7. Press left arrow (B) to enable DRAPER SPEED control switch, or press right arrow (C) to lock DRAPER SPEED control switch.
8. Press PROGRAM (A) to exit Programming Mode or press SELECT (D) to proceed to next WINDROWER SETUP action.

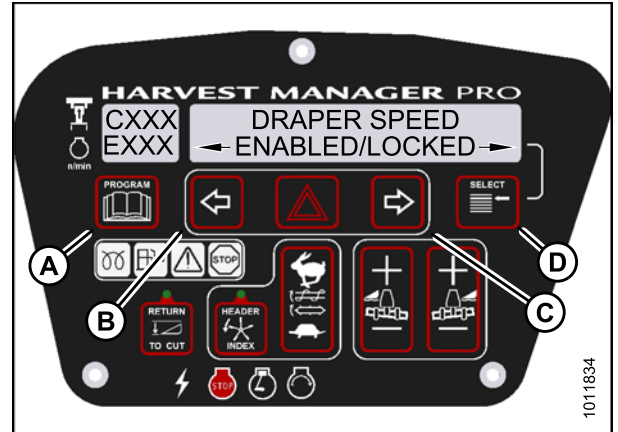

Figure 3.150: Draper Control Lock

### Activating the Auger Speed Control Lock Out

#### NOTE:

- This procedure is for A40-D Headers only.
  - An auger header **MUST** be attached to the windrower to perform this procedure. The cab display module (CDM) automatically adjusts its programming for each header. For more information, refer to [4.5 Attaching and Detaching Headers, page 214](#).
1. Turn ignition key to RUN, or start the engine.
  2. Press PROGRAM (A) and SELECT (C) on cab display module (CDM) to enter Programming Mode.
    - WINDROWER SETUP? is displayed on the upper line.
    - NO/YES is displayed on the lower line.
  3. Press right (B) arrow to select YES. Press SELECT (C).
    - SET KNIFE SPEED? is displayed on the upper line.

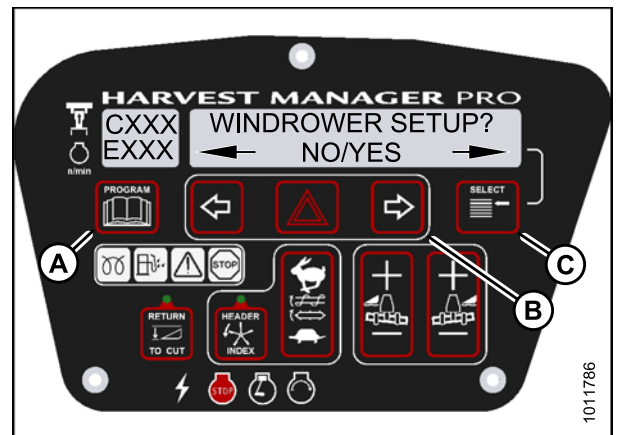

Figure 3.151: CDM Programming Buttons

## OPERATOR'S STATION

4. Press SELECT (B) until SET CONTROL LOCKS? is displayed on the upper line.
  - NO/YES is displayed on the lower line.
5. Press right (A) arrow to select YES. Press SELECT (B).

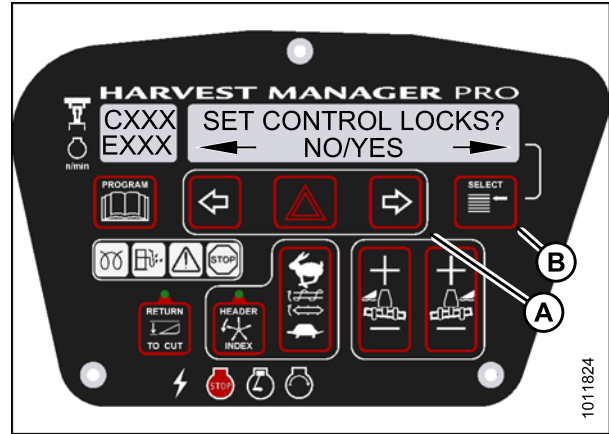

Figure 3.152: Control Locks

6. Press SELECT (D) until AUGER SPEED is displayed on the upper line.
  - ENABLED/LOCKED is displayed on the lower line.
7. Press left (B) arrow to enable AUGER SPEED control switch. Press right (C) arrow to lock AUGER SPEED control switch.
8. Press PROGRAM (A) to exit Programming Mode, or press SELECT (D) to proceed to next WINDROWER SETUP action.

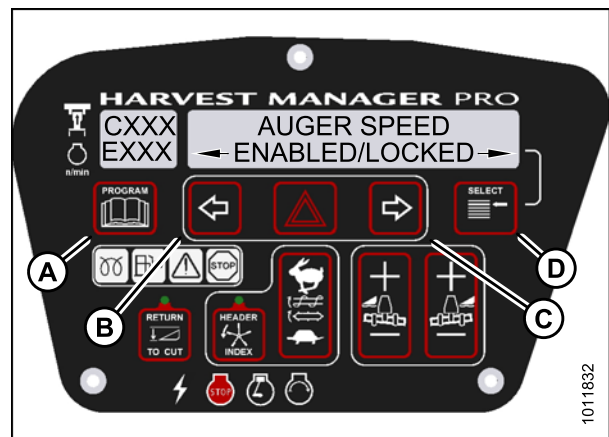

Figure 3.153: Auger Control Lock

### Activating the Reel Speed Control Lock Out

#### NOTE:

The header **MUST** be attached to the windrower to perform this procedure. The cab display module (CDM) automatically adjusts its programming for each header. For more information, refer to [4.5 Attaching and Detaching Headers, page 214](#).

1. Turn ignition key to RUN, or start the engine.
2. Press PROGRAM (A) and SELECT (C) on cab display module (CDM) to enter Programming Mode.
  - WINDROWER SETUP? is displayed on the upper line.
  - NO/YES is displayed on the lower line.
3. Press right (B) arrow to select YES. Press SELECT (C).
  - SET KNIFE SPEED? is displayed on the upper line.

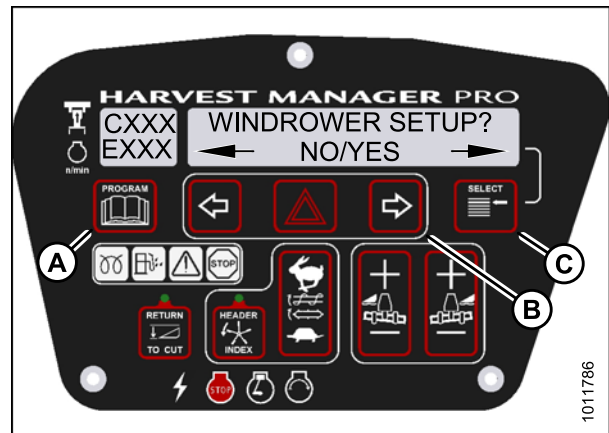

Figure 3.154: CDM Programming Buttons

## OPERATOR'S STATION

4. Press SELECT (B) until SET CONTROL LOCKS? is displayed on the upper line.
  - NO/YES is displayed on the lower line.
5. Press right (A) arrow to select YES. Press SELECT (B).

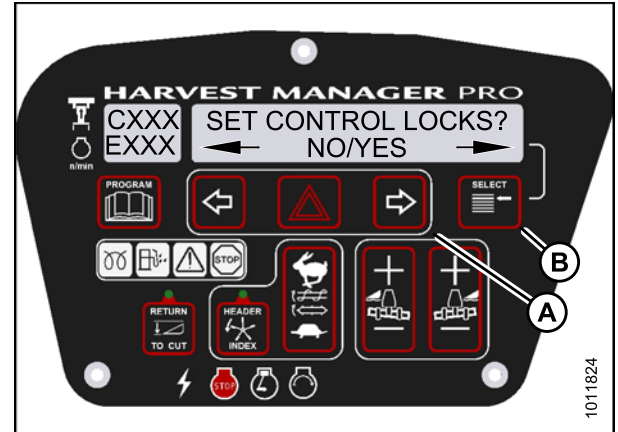

Figure 3.155: Control Locks

6. Press SELECT (D) until REEL SPEED is displayed on the upper line.
  - ENABLED/LOCKED is displayed on the lower line.
7. Press left (B) arrow to enable REEL SPEED control switch.  
Press right (C) arrow to lock REEL SPEED control switch.
8. Press PROGRAM (A) to exit Programming Mode, or press SELECT (D) to proceed to next WINDROWER SETUP action.

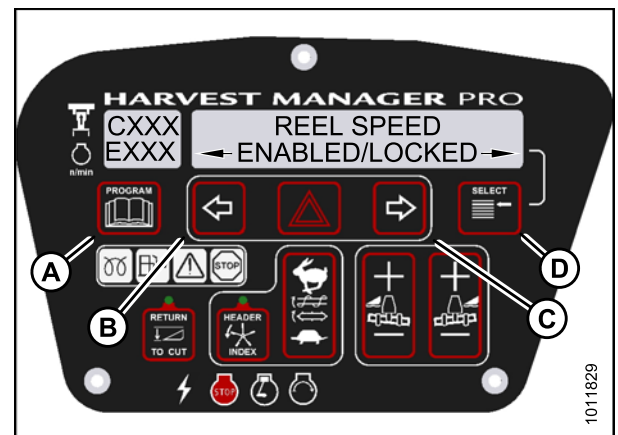

Figure 3.156: Reel Speed Control Lock

### Activating the Reel Fore-Aft Control Lock Out

#### NOTE:

- This procedure is for draper headers only.
- The header **MUST** be attached to the windrower to perform this procedure. The cab display module (CDM) automatically adjusts its programming for each header. For more information, refer to [4.5 Attaching and Detaching Headers, page 214](#).

## OPERATOR'S STATION

1. Turn ignition key to RUN, or start the engine.
2. Press PROGRAM (A) and SELECT (C) on cab display module (CDM) to enter Programming Mode.
  - WINDROWER SETUP? is displayed on the upper line.
  - NO/YES is displayed on the lower line.
3. Press right (B) arrow to select YES. Press SELECT (C).
  - SET KNIFE SPEED? is displayed on the upper line.

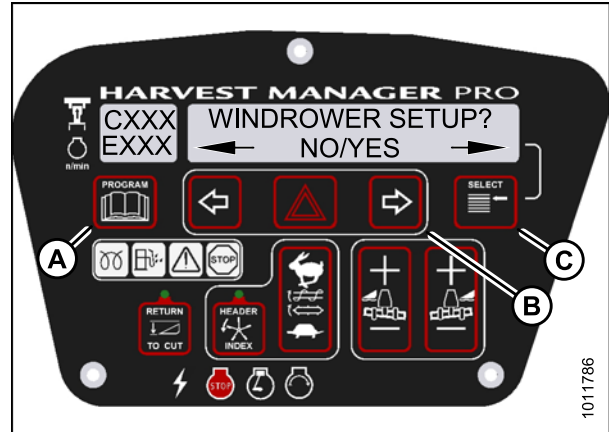

Figure 3.157: CDM Programming Buttons

4. Press SELECT (B) until SET CONTROL LOCKS? is displayed on the upper line.
  - NO/YES is displayed on the lower line.
5. Press right (A) arrow to select YES. Press SELECT (B).



Figure 3.158: Control Locks

6. Press SELECT (D) until REEL FORE/AFT is displayed on the upper line.
  - ENABLED/LOCKED is displayed on the lower line.
7. Press left (B) arrow to enable REEL FORE/AFT control switch. Press right (C) arrow to lock REEL FORE/AFT control switch.
8. Press PROGRAM (A) to exit Programming Mode, or press SELECT (D) to proceed to next WINDROWER SETUP action.

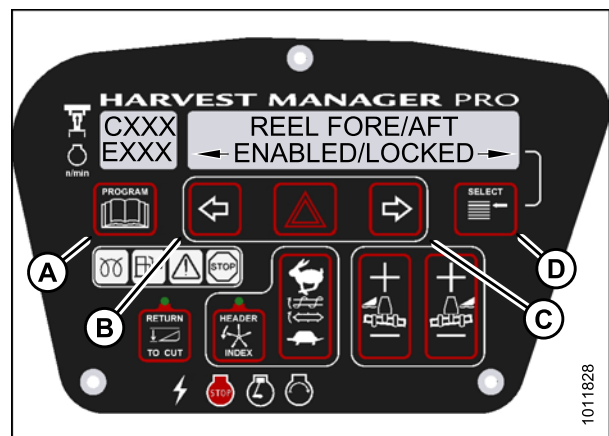

Figure 3.159: Reel Fore-Aft Control Lock

### Activating the Header Tilt Control Lock Out

#### NOTE:

- The header **MUST** be attached to the windrower to perform this procedure. The cab display module (CDM) automatically adjusts its programming for each header. For more information, refer to [4.5 Attaching and Detaching Headers, page 214](#).

## OPERATOR'S STATION

1. Turn ignition key to RUN, or start the engine.
2. Press PROGRAM (A) and SELECT (C) on cab display module (CDM) to enter Programming Mode.
  - WINDROWER SETUP? is displayed on the upper line.
  - NO/YES is displayed on the lower line.
3. Press right (B) arrow to select YES. Press SELECT (C).
  - SET KNIFE SPEED? is displayed on the upper line.

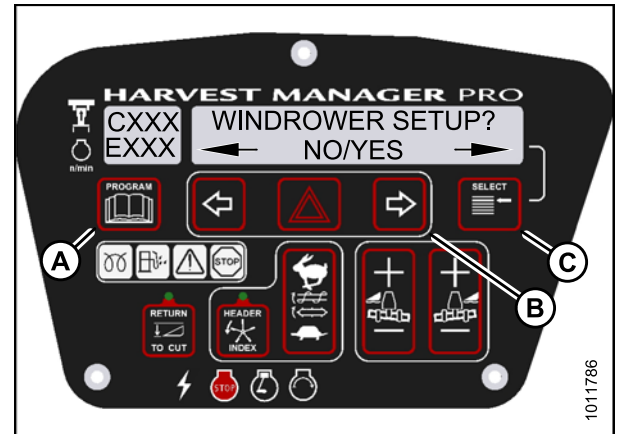

Figure 3.160: CDM Programming Buttons

4. Press SELECT (B) until SET CONTROL LOCKS? is displayed on the upper line.
  - NO/YES is displayed on the lower line.
5. Press right (A) arrow to select YES. Press SELECT (B).

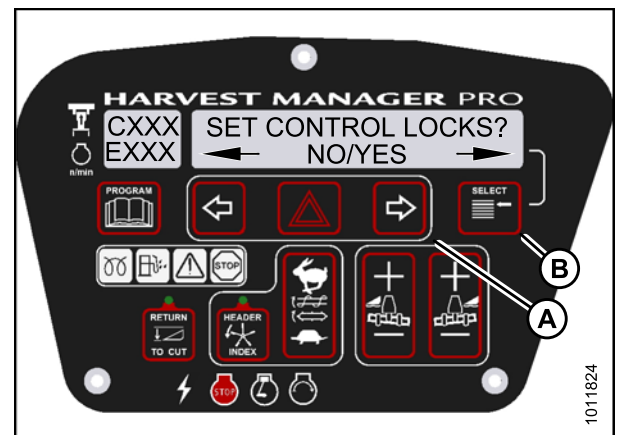

Figure 3.161: Control Locks

6. Press SELECT (D) until HEADER TILT is displayed on the upper line.
  - ENABLED/LOCKED is displayed on the lower line.
7. Press left (B) arrow to enable HEADER TILT control switch. Press right (C) arrow to lock HEADER TILT control switch.
8. Press PROGRAM (A) to exit Programming Mode, or press SELECT (D) to proceed to next WINDROWER SETUP action.

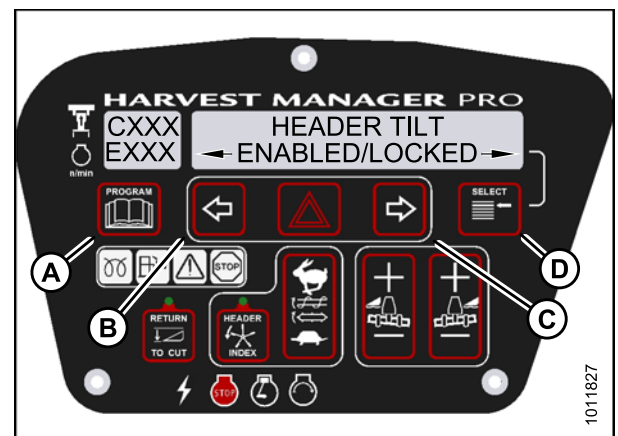

Figure 3.162: Header Tilt Control Lock

### 3.19.11 Displaying Activated Cab Display Lock Outs

Displaying the activated control locks allows you to quickly determine which controls are locked on the cab display module (CDM).

1. Turn ignition key to RUN, or start the engine.
2. Press PROGRAM (A) and SELECT (C) on cab display module (CDM) to enter Programming Mode.
  - WINDROWER SETUP? is displayed on the upper line.
  - NO/YES is displayed on the lower line.
3. Press right (B) arrow to select YES. Press SELECT (C).
  - SET KNIFE SPEED? is displayed on the upper line.

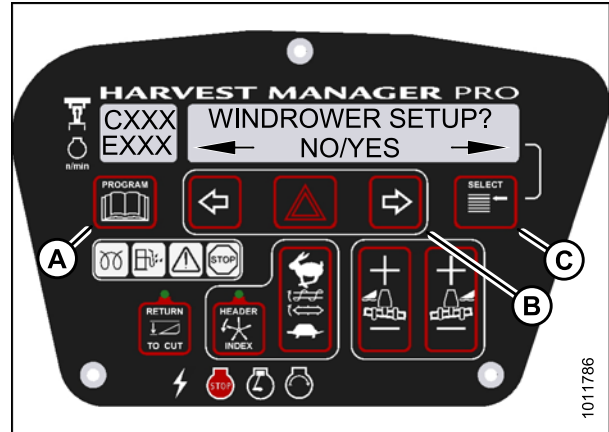

Figure 3.163: CDM Programming Buttons

4. Press SELECT (B) until VIEW CONTROL LOCKS? is displayed on the upper line.
  - NO/YES is displayed on the lower line.
5. Press right (A) arrow to select YES. Press SELECT (B).
  - HEADER TILT is displayed on the upper line.
  - The control switch status is displayed on the lower line. The hours displayed indicate when a switch was enabled or locked.

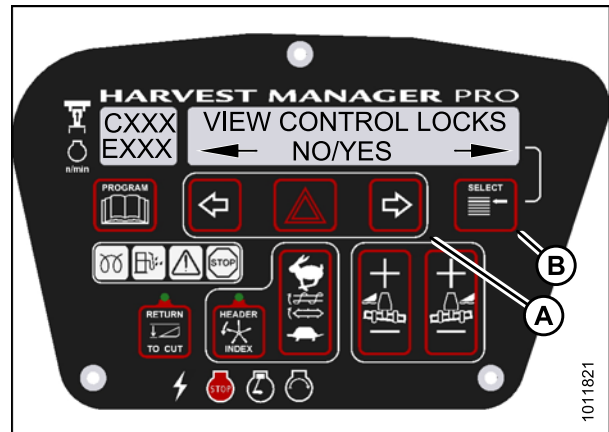

Figure 3.164: Control Locks

## OPERATOR'S STATION

6. Press left (B) or right (C) arrow to cycle between control switch lock outs. The displayed control switches are as follows:
  - HEADER TILT
  - HEADER FLOAT
  - REEL FORE/AFT
  - DRAPER SPEED
  - AUGER SPEED
  - KNIFE SPEED
  - DISK SPEED
  - REEL SPEED

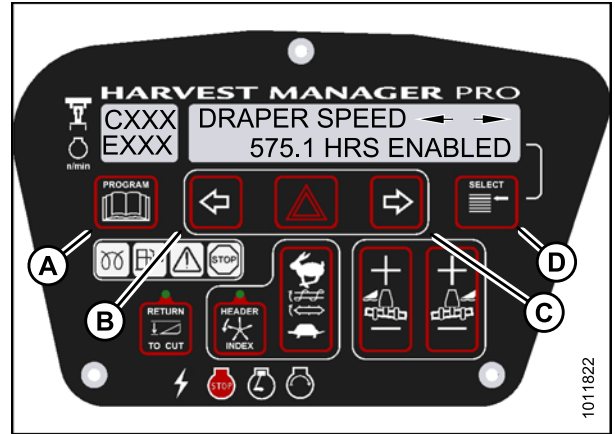

Figure 3.165: Control Locks

### NOTE:

Not all control locks apply to every header.

7. Press SELECT.
  - EXIT VIEW LOCKOUTS? is displayed on the upper line.
  - NO/YES is displayed on the lower line.
8. Press right to select YES.
9. Press PROGRAM to exit Programming Mode or press SELECT to proceed to next WINDROWER SETUP action.

## 3.19.12 Troubleshooting Windrower Problems

### *Displaying the Windrower and Engine Error Codes*

### NOTE:

The header **MUST** be attached to the windrower to perform this procedure. The cab display module (CDM) automatically adjusts its programming for each header. For more information, refer to [4.5 Attaching and Detaching Headers, page 214](#).

## OPERATOR'S STATION

1. Turn ignition key to RUN, or start the engine.
2. Press PROGRAM (A) and SELECT (C) on cab display module (CDM) to enter Programming Mode. Press SELECT (C).
  - WINDROWER SETUP? is displayed on the upper line.
3. Press SELECT (C) until DIAGNOSTIC MODE? is displayed in upper line.
  - NO/YES is displayed on the lower line.

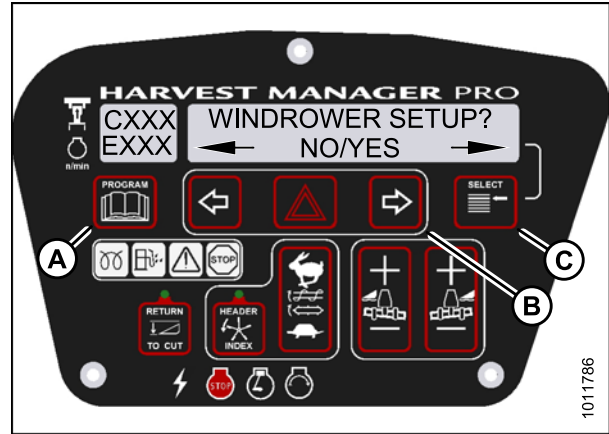

Figure 3.166: CDM Programming Buttons

4. Press right (A) arrow to select Yes. Press SELECT (B).
5. VIEW ERROR CODES? is displayed on the upper line.
  - NO/YES is displayed on the lower line.
6. Press right (A) arrow to select YES. Press SELECT (B).
  - VIEW WINDRWR CODES? is displayed on the upper line.
  - NO/YES is displayed on the lower line.

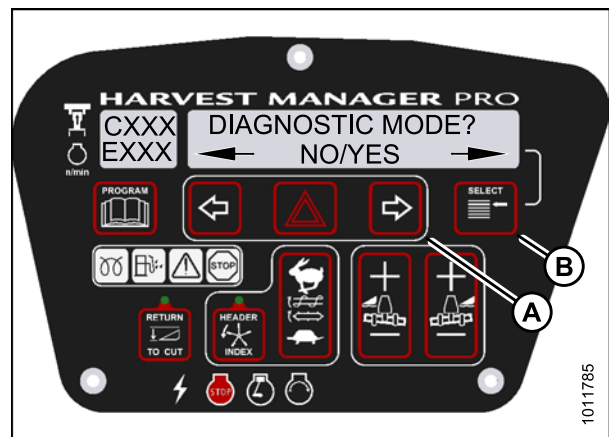

Figure 3.167: Diagnostic Functions

7. Press right (C) arrow to select YES. Press SELECT (D).
  - The most recent error code will be displayed.
  - Refer to [8.8.1 Cab Display Module \(CDM\) Error Codes, page 490](#).
8. Press and left (B) or right (C) arrow to cycle through the last ten recorded windrower error codes until EXIT WINDROWER CODES is displayed.
9. Press right (C) arrow to select YES. Press SELECT (D).
  - VIEW ENGINE CODES is displayed on the upper line.
  - NO/YES is displayed on the lower line.

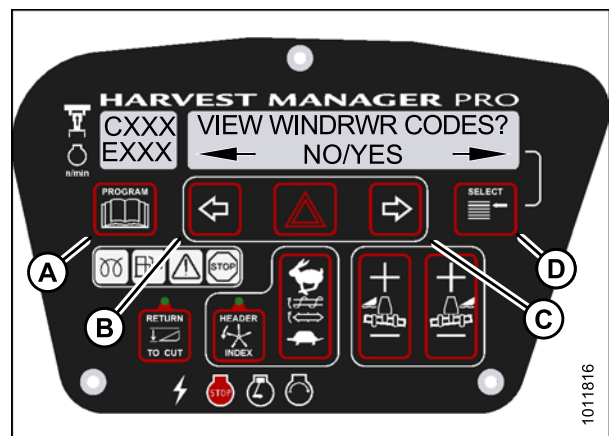

Figure 3.168: Windrower Codes



## OPERATOR'S STATION

10. Press right (C) arrow to select YES. Press SELECT (D).
11. Press left (B) or right (C) arrow to cycle through the last ten recorded engine error codes until EXIT ENGINE CODES is displayed.
  - Refer to [8.4 Engine Error Codes, page 459](#).
12. Press right (C) arrow to select YES. Press SELECT (D).
13. Press PROGRAM (A) to exit Programming Mode or press SELECT (D) to proceed to next DIAGNOSTIC MODE.

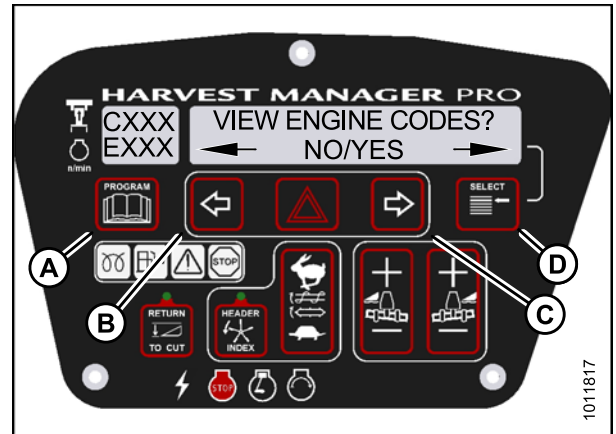

Figure 3.169: Engine Codes

### Switching the Installed Header Sensors On or Off

You can selectively enable or disable header sensors in the event of a malfunction or as part of a troubleshooting routine.

#### NOTE:

- The header **MUST** be attached to the windrower to perform this procedure. The cab display module (CDM) automatically adjusts its programming for each header. For more information, refer to [4.5 Attaching and Detaching Headers, page 214](#).
- Disabled sensors flash the word SENSOR on CDM during regular operation.

1. Turn ignition key to RUN, or start the engine.
2. Press PROGRAM (A) and SELECT (C) on cab display module (CDM) to enter Programming Mode.
  - WINDROWER SETUP? is displayed on the upper line.
  - NO/YES is displayed on the lower line.
3. Press SELECT (C) until DIAGNOSTIC MODE? is displayed on the upper line.
  - NO/YES is displayed on the lower line.
4. Press right (B) arrow to select Yes. Press SELECT (C).
  - VIEW ERROR CODES? is displayed on the upper line.

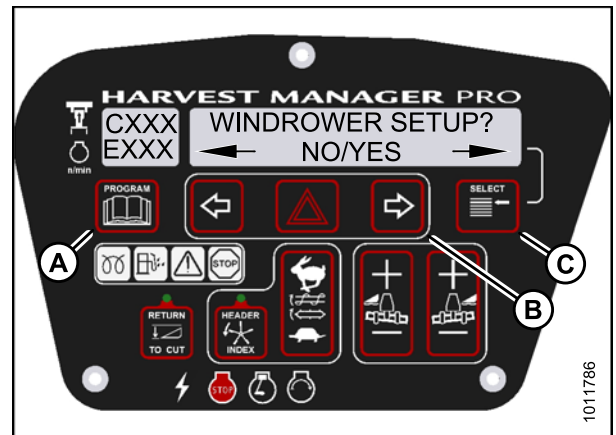

Figure 3.170: CDM Programming Buttons

## OPERATOR'S STATION

5. Press SELECT (B) until ENTER SENSOR SETUP? is displayed on the upper line.
  - NO/YES is displayed on the lower line.
6. Press right (A) arrow to select Yes. Press SELECT (B).
  - KNIFE SPEED SENSOR is displayed on the lower line.
  - ENABLE/DISABLE is displayed on the lower line.

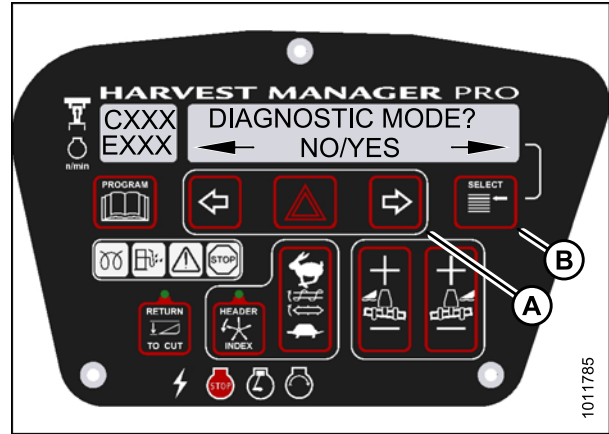

Figure 3.171: Diagnostic Functions

7. Press left (B) arrow to enable a sensor. Press right (C) arrow to disable sensor. Press SELECT (D) to confirm selection and move on to next sensor. The following sensors are available:
  - HEADER HT SENSOR
  - HEADER TILT SENSOR
  - KNIFE SPEED SENSOR
  - REEL SPEED SENSOR
  - HEADER FLOAT SENSOR
  - OVERLOAD PRESSURE<sup>14</sup>
  - HYD OIL TEMP SENSOR

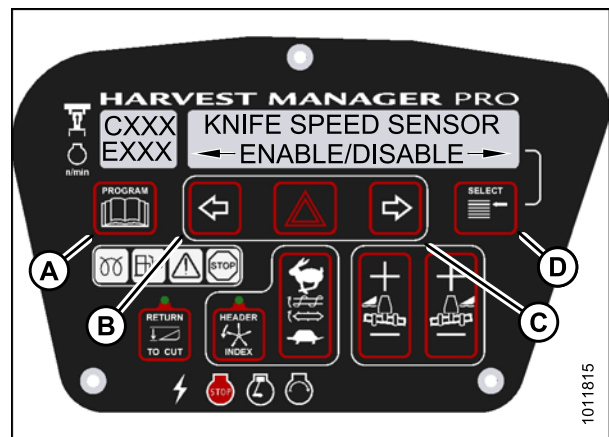

Figure 3.172: Header Sensors

When sensors have been modified, press SELECT (D) to display the EXIT SENSOR SETUP? selection.

8. Press right arrow to select YES. Press SELECT.
9. Press PROGRAM to exit Programming Mode or press SELECT to proceed to next DIAGNOSTIC MODE.

### Displaying Header Sensor Input Signals

You can display individual sensor input signals in the event of a malfunction or as part of a troubleshooting routine.

#### NOTE:

The header **MUST** be attached to the windrower to perform this procedure. The cab display module (CDM) automatically adjusts its programming for each header. For more information, refer to [4.5 Attaching and Detaching Headers, page 214](#).

---

14. Requires installation of optional pressure sensor (MD #5574).

## OPERATOR'S STATION

1. Turn ignition key to RUN, or start the engine.
2. Press PROGRAM (A) and SELECT (C) on cab display module (CDM) to enter Programming Mode.
  - WINDROWER SETUP? is displayed on the upper line.
  - NO/YES is displayed on the lower line.

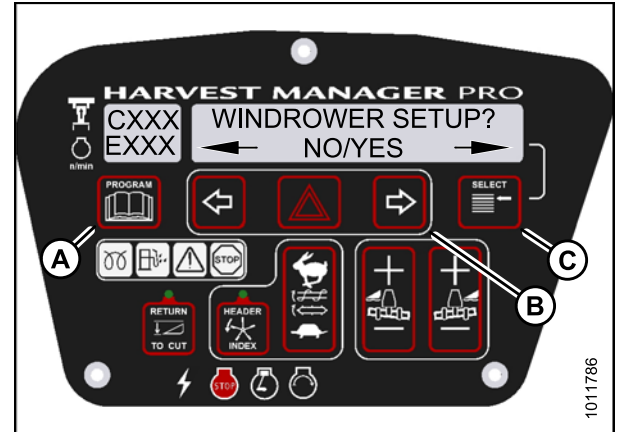

Figure 3.173: CDM Programming Buttons

3. Press SELECT (B) until DIAGNOSTIC MODE? is displayed on the upper line.
  - NO/YES is displayed on the lower line.
4. Press right (A) arrow to select YES. Press SELECT (B).
  - VIEW ERROR CODES? is displayed on the upper line.
5. Press SELECT (B) until READ SENSOR SETUP? is displayed on the upper line.
  - NO/YES is displayed on the lower line.

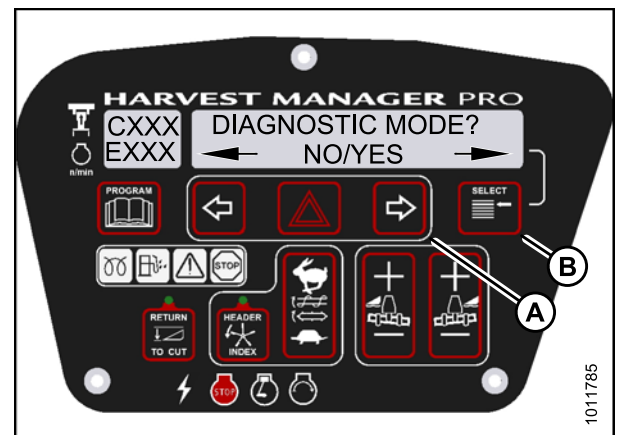

Figure 3.174: Diagnostic Functions

6. Press right (C) arrow to select Yes. Press SELECT (D).
  - SENSOR INPUT is displayed on the upper line.
  - HDR HEIGHT 1.23 V is displayed on the lower line.
7. Press left (B) or right (C) arrow to cycle between individual sensor readers.
8. Press SELECT (D) to skip to EXIT READ SENSORS? selection.

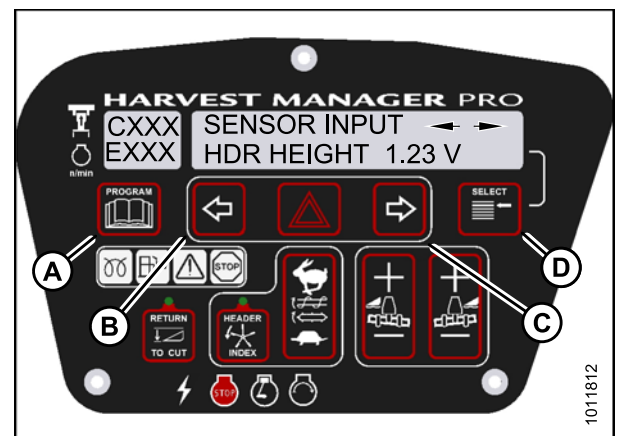

Figure 3.175: Header Sensors

9. Press right arrow to select YES. Press SELECT.
10. Press PROGRAM to exit Programming Mode or press SELECT to proceed to next DIAGNOSTIC MODE.

## OPERATOR'S STATION

### Forcing a Header ID

The header must be attached to the windrower to troubleshoot certain issues. If damage has occurred to the header wiring or no header is available, you can force the windrower control module (WCM) to read a header ID. The WCM reverts to reading NO HEADER each time the engine ignition is cycled.

#### IMPORTANT:

Forcing a Header ID that is different from the attached header can damage the windrower and header. Doing so can lead to vibration, belt failures, and other over-speeding related problems.

1. Turn ignition key to RUN, or start the engine.
2. Press PROGRAM (A) and SELECT (C) on cab display module (CDM) to enter Programming Mode.
  - WINDROWER SETUP? is displayed on the upper line.

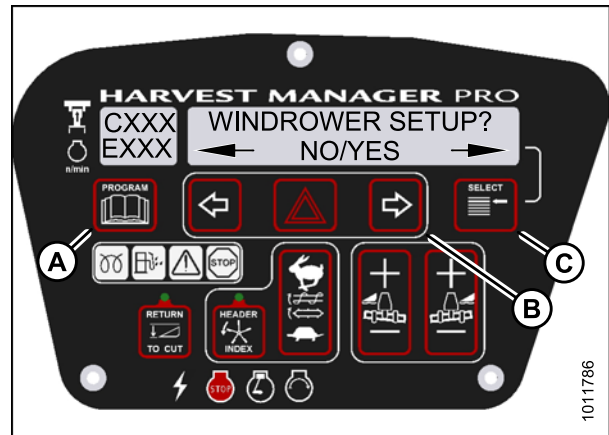

Figure 3.176: CDM Programming Buttons

3. Press SELECT (B) until DIAGNOSTIC MODE? is displayed in upper line.
  - NO/YES is displayed on the lower line.
4. Press right (A) arrow to select Yes. Press SELECT (B).

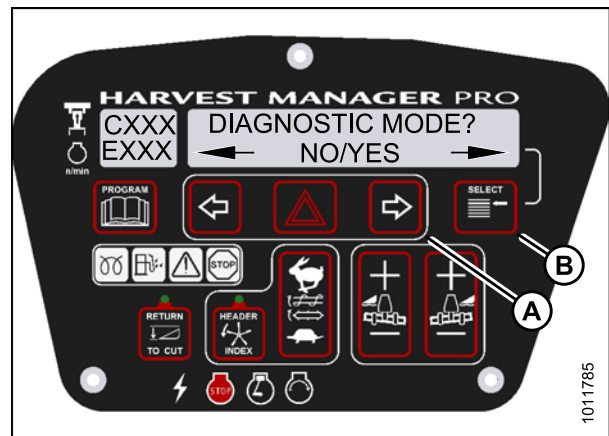

Figure 3.177: Diagnostic Functions

## OPERATOR'S STATION

5. Press SELECT (B) until FORCE HEADER TYPE? is displayed on the upper line.
  - NO/YES is displayed on the lower line.
6. Press right (A) arrow to select YES. Press SELECT (B).
  - SELECT HEADER TYPE is displayed on the upper line.
  - DISK HEADER is displayed on the lower line.

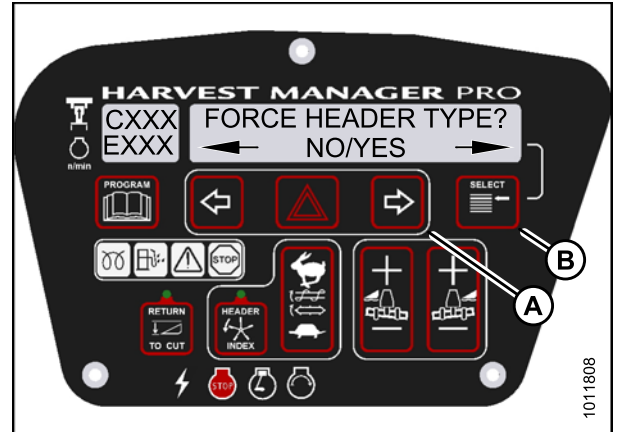

Figure 3.178: Header Type

7. Press left (A) or right (B) arrow to cycle through list of header types.
8. When desired header type is displayed press SELECT (C).
  - EXIT FORCE HEADER? is displayed on the upper line.
  - NO/YES is displayed on the lower line.
9. Press right arrow (B) to select YES. Press SELECT (C). Proceed to next DIAGNOSTIC MODE or press PROGRAM to exit programming mode.

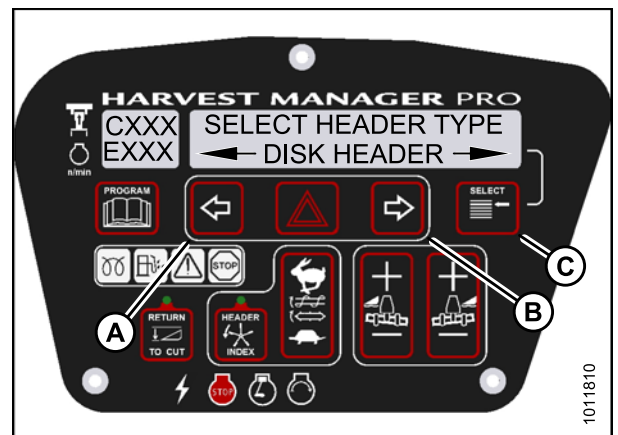

Figure 3.179: Header Type

### 3.19.13 Troubleshooting Header Problems

You can test individual parts of the header as part of a troubleshooting routine.

*Testing the Header Up/Down Activate Function Using the Cab Display Module (CDM)*

#### NOTE:

- The header **MUST** be attached to the windrower to perform this procedure. The cab display module (CDM) automatically adjusts its programming for each header. For more information, refer to [4.5 Attaching and Detaching Headers, page 214](#).
- The engine **MUST** be running to perform this procedure.

## OPERATOR'S STATION

1. Turn ignition key to RUN, or start the engine.
2. Press PROGRAM (A) and SELECT (C) on cab display module (CDM) to enter Programming Mode. Press SELECT (C).
  - WINDROWER SETUP? is displayed on the upper line.

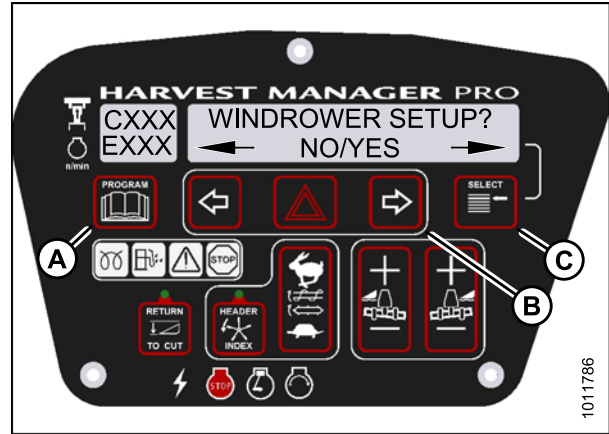

Figure 3.180: CDM Programming Buttons

3. Press SELECT (B) until DIAGNOSTIC MODE? is displayed in upper line.
  - NO/YES is displayed on the lower line.
4. Press right (A) arrow to select Yes. Press SELECT (B).

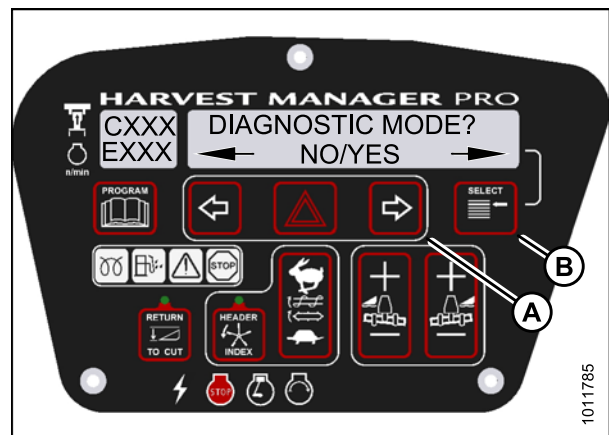

Figure 3.181: Diagnostic Functions

5. Press SELECT (B) until ACTIVATE FUNCTIONS? is displayed on the upper line.
  - NO/YES is displayed on the lower line.
6. Press right (A) arrow to select YES. Press SELECT (B).

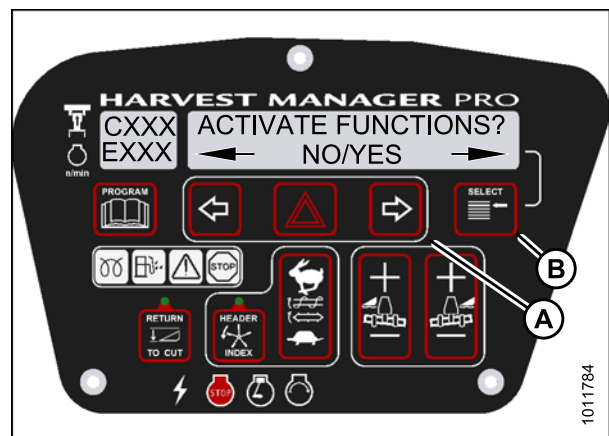

Figure 3.182: Functions

## OPERATOR'S STATION

### CAUTION

Check to be sure all bystanders have cleared the area.

- Press SELECT (D) until ACTIVATE HEADER HT is displayed on the upper line.
  - DOWN/UP is displayed on the lower line.
- Press and hold left (B) arrow to lower header, or press and hold right (C) arrow to raise header. Verify header is functioning properly.
- Press PROGRAM (A) to exit Programming Mode or press SELECT (D) to proceed to next ACTIVATE FUNCTION.

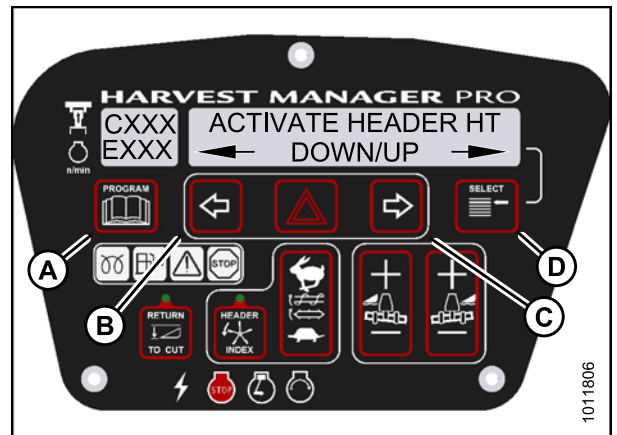

Figure 3.183: Header Height

### *Testing the Reel Up/Down Activate Function Using the Cab Display Module (CDM)*

#### NOTE:

- This procedure is for draper headers only.
  - The header **MUST** be attached to the windrower to perform this procedure. The cab display module (CDM) automatically adjusts its programming for each header.
- Turn ignition key to RUN, or start the engine.
  - Press PROGRAM (A) and SELECT (C) on cab display module (CDM) to enter Programming Mode. Press SELECT (C).
    - WINDROWER SETUP? is displayed on the upper line.

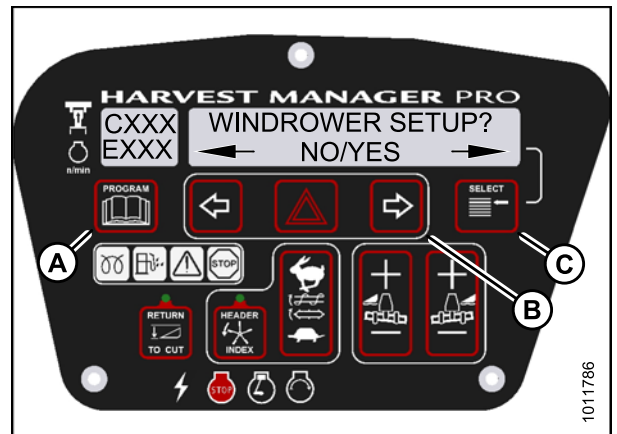

Figure 3.184: CDM Programming Buttons

## OPERATOR'S STATION

3. Press SELECT (B) until DIAGNOSTIC MODE? is displayed in upper line.
  - NO/YES is displayed on the lower line.
4. Press right (A) arrow to select Yes. Press SELECT (B).

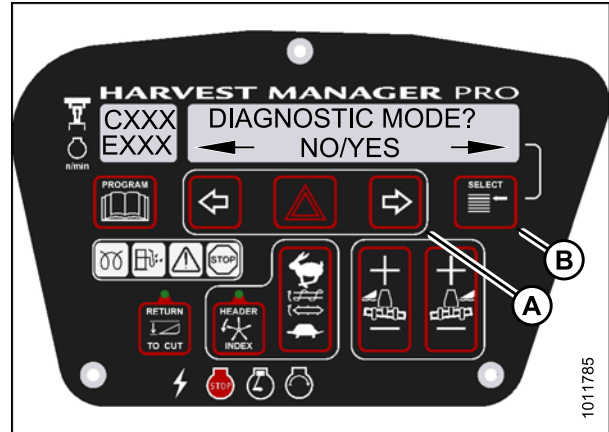

Figure 3.185: Diagnostic Functions

5. Press SELECT (D) until ACTIVATE FUNCTIONS? is displayed on the upper line.
  - NO/YES is displayed on the lower line.
6. Press right (C) arrow to select YES. Press SELECT (D).



Figure 3.186: Functions

### CAUTION

Check to be sure all bystanders have cleared the area.

7. Press SELECT (D) until ACTIVATE REEL HT is displayed on the upper line.
  - DOWN/UP is displayed on the lower line.
8. Press and hold left (B) arrow to **lower** reel. Press and hold right (C) arrow to **raise** reel.  
**Verify reel is functioning properly.**
9. Press PROGRAM (A) to exit Programming Mode or press SELECT (D) to proceed to next ACTIVATE FUNCTION.

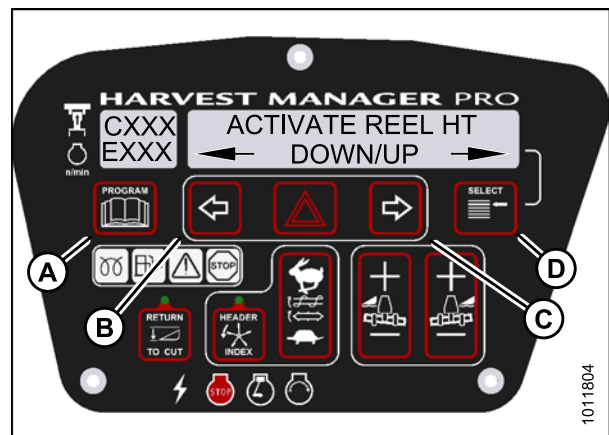

Figure 3.187: Reel Height



## OPERATOR'S STATION

### Testing the Header Tilt Activate Function Using the Cab Display Module (CDM)

#### NOTE:

- The header **MUST** be attached to the windrower to perform this procedure. The cab display module (CDM) automatically adjusts its programming for each header. For more information, refer to [4.5 Attaching and Detaching Headers, page 214](#).
  - The engine **MUST** be running to perform this procedure.
1. Turn ignition key to RUN, or start the engine.
  2. Press PROGRAM (A) and SELECT (C) on cab display module (CDM) to enter Programming Mode.
    - WINDROWER SETUP? is displayed on the upper line.

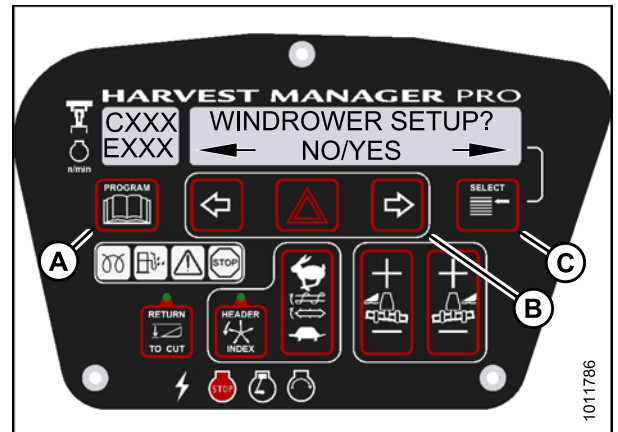

Figure 3.188: CDM Programming Buttons

3. Press SELECT (B) until DIAGNOSTIC MODE? is displayed in upper line.
  - NO/YES is displayed on the lower line.
4. Press right (A) arrow to select Yes. Press SELECT (B).

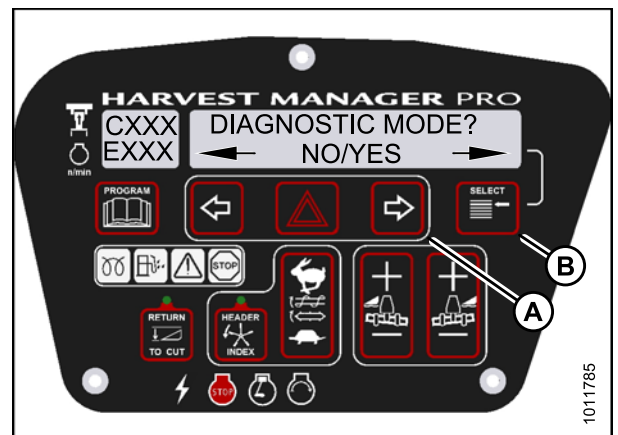

Figure 3.189: Diagnostic Functions

## OPERATOR'S STATION

5. Press SELECT (D) until ACTIVATE FUNCTIONS? is displayed on the upper line.
  - NO/YES is displayed on the lower line.
6. Press right (C) arrow to select YES. Press SELECT (D).



Figure 3.190: Functions

### **CAUTION**

Check to be sure all bystanders have cleared the area.

7. Press SELECT (D) until ACTIVATE HDR TILT is displayed on the upper line.
  - IN/OUT is displayed on the lower line.
8. Press and hold left (B) arrow to **decrease** header tilt. Press and hold right (C) arrow to **increase** header tilt. **Verify header is functioning properly.**
9. Press PROGRAM (A) to exit Programming Mode or press SELECT (D) to proceed to next ACTIVATE FUNCTION.

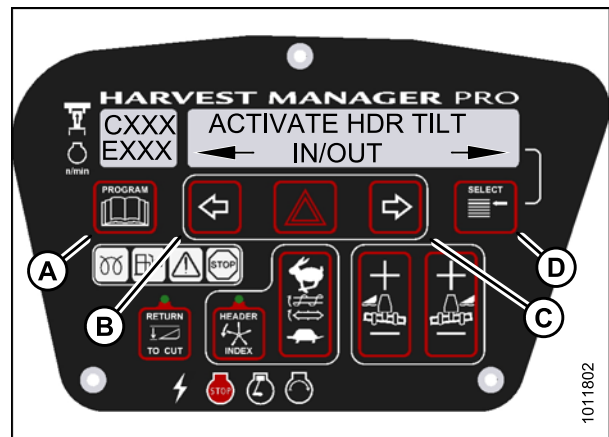

Figure 3.191: Header Tilt Angle

### Testing the Reel Fore-Aft Activate Function Using the Cab Display Module (CDM)

#### NOTE:

- The header **MUST** be attached to windrower to perform this procedure. For more information, refer to [4.5 Attaching and Detaching Headers, page 214](#).
  - The engine **MUST** be running to perform this procedure.
1. Turn ignition key to RUN, or start the engine.
  2. Press PROGRAM (A) and SELECT (C) on cab display module (CDM) to enter Programming Mode.
    - WINDROWER SETUP? is displayed on the upper line.

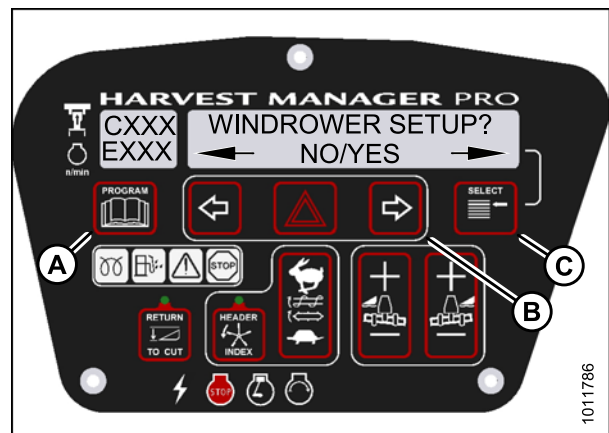

Figure 3.192: CDM Programming Buttons

## OPERATOR'S STATION

3. Press SELECT (B) until DIAGNOSTIC MODE? is displayed in upper line.
  - NO/YES is displayed on the lower line.
4. Press right (A) arrow to select Yes. Press SELECT (B).

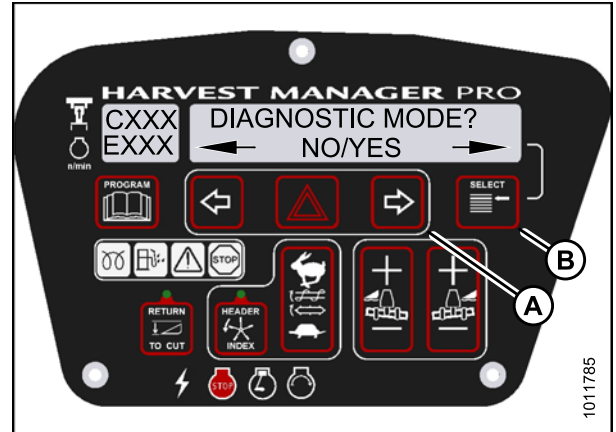

Figure 3.193: Diagnostic Functions

5. Press SELECT (D) until ACTIVATE FUNCTIONS? is displayed on the upper line.
  - NO/YES is displayed on the lower line.
6. Press right (C) arrow to select YES. Press SELECT (D).

### CAUTION

Check to be sure all bystanders have cleared the area.

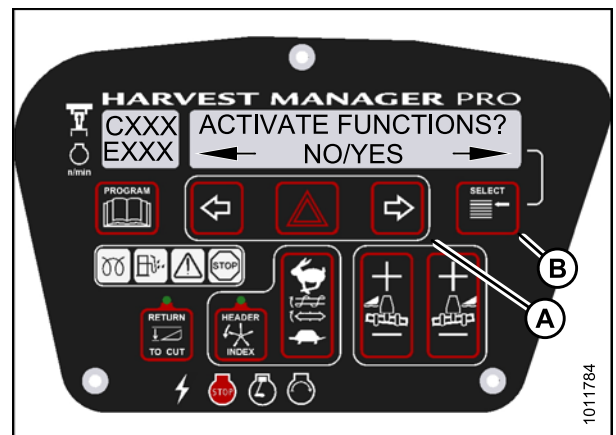

Figure 3.194: Functions

7. Press SELECT (D) until ACTIVATE REEL F/A is displayed on the upper line.
  - FORE/AFT is displayed on the lower line.
8. Press and hold left (B) arrow to move reel **forward**. Press and hold right (C) arrow to move reel **backward**. **Verify reel fore-aft is functioning properly.**
9. Press PROGRAM (A) to exit Programming Mode or press SELECT (D) to proceed to next ACTIVATE FUNCTION.

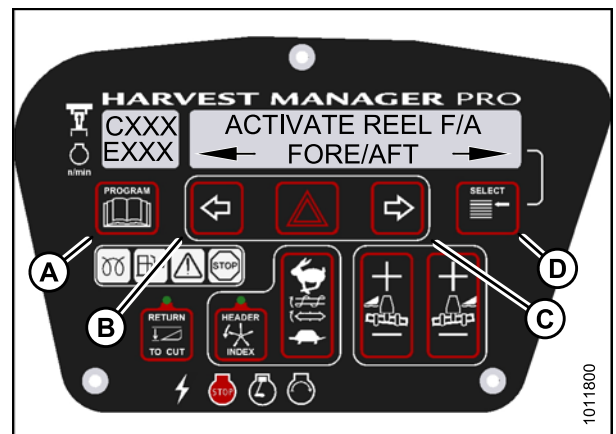

Figure 3.195: Reel Fore-Aft

### Activating the Hydraulic Purge Using the Cab Display Module (CDM)

The hydraulic purge removes air from the hydraulic pump system after it has been repaired or changed.

#### NOTE:

Engine **MUST** be running to perform this procedure.

## OPERATOR'S STATION

1. Turn ignition key to RUN, or start the engine.
2. Press PROGRAM (A) and SELECT (C) on cab display module (CDM) to enter Programming Mode.
  - WINDROWER SETUP? is displayed on the upper line.

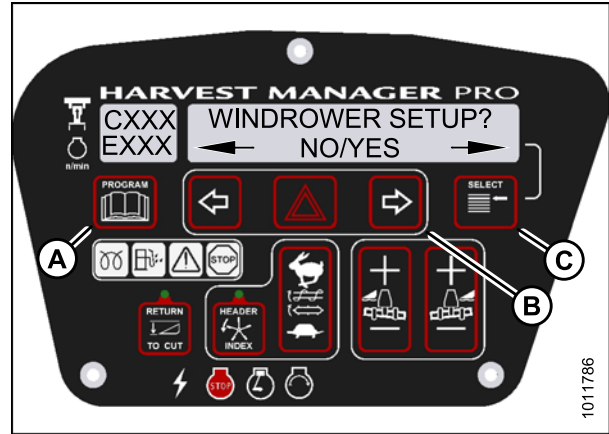

Figure 3.196: CDM Programming Buttons

3. Press SELECT (B) until DIAGNOSTIC MODE? is displayed in upper line.
  - NO/YES is displayed on the lower line.
4. Press right (A) arrow to select Yes. Press SELECT (B).

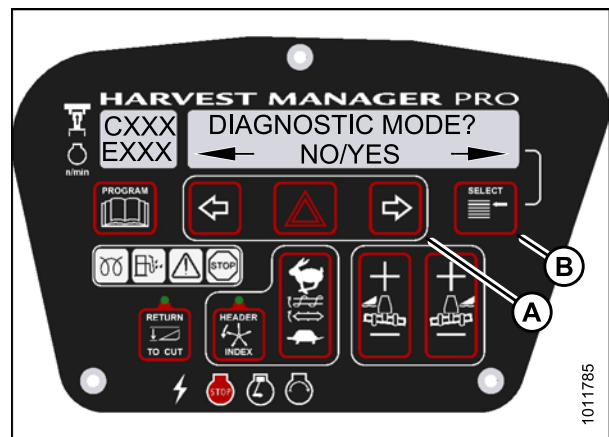

Figure 3.197: Diagnostic Functions

5. Press SELECT (B) until ACTIVATE FUNCTIONS? is displayed on the upper line.
  - NO/YES is displayed on the lower line.
6. Press right (A) arrow to select YES. Press SELECT (B).
  - ACTIVATE HEADER HT is displayed on the upper line.
  - DOWN/UP is displayed on the lower line.

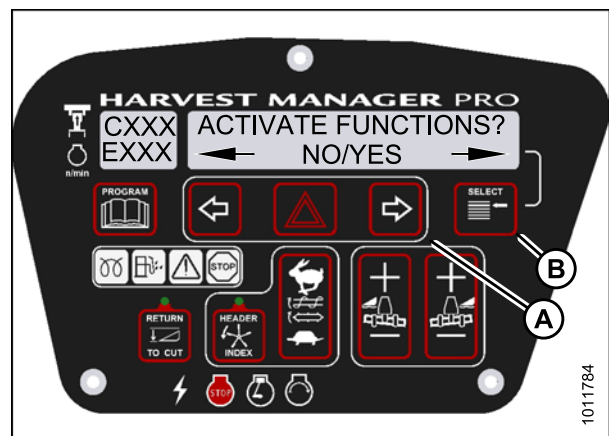

Figure 3.198: Functions

## OPERATOR'S STATION

7. Press SELECT (B) until ACTIVATE HYD PURGE? is displayed on the upper line.
  - NO/YES is displayed on the lower line.
8. Press right (A) arrow to select YES. Press SELECT (B).
  - TO ACTIVATE PURGE is displayed on the upper line.
  - PRESS AND HOLD is displayed on the lower line.

### CAUTION

Check to be sure all bystanders have cleared the area.

#### NOTE:

Holding the right arrow (A) activates a timed purge cycle. The CDM will jump to the exit menu if the arrow is released before the end of the timed cycle.

9. Press and hold right (A) arrow to activate purge cycle.
  - PURGE CYCLE STARTED will display on the upper line.
10. When PURGE CYCLE ENDED is displayed release right (A) arrow.
  - NO EXIT YES is displayed on the lower line.
11. Press right arrow to select YES. Press SELECT.
12. Press PROGRAM to exit Programming Mode or press SELECT to proceed to next ACTIVATE FUNCTION.



Figure 3.199: Hydraulic Purge



Figure 3.200: Hydraulic Purge Cycle

### *Testing the Knife Drive Circuit Using the Cab Display Module (CDM)*

#### IMPORTANT:

Do not over-speed a drive for a significant length of time. Doing so can lead to vibration, belt failures, or other over-speeding related problems.

#### NOTE:

- The header **MUST** be attached to windrower to follow this procedure. For more information, refer to [4.5 Attaching and Detaching Headers, page 214](#).
- The engine **MUST** be running to perform this procedure.

## OPERATOR'S STATION

1. Turn ignition key to RUN, or start the engine.
2. Press PROGRAM (A) and SELECT (C) on cab display module (CDM) to enter Programming Mode. Press SELECT (C).
  - WINDROWER SETUP? is displayed on the upper line.

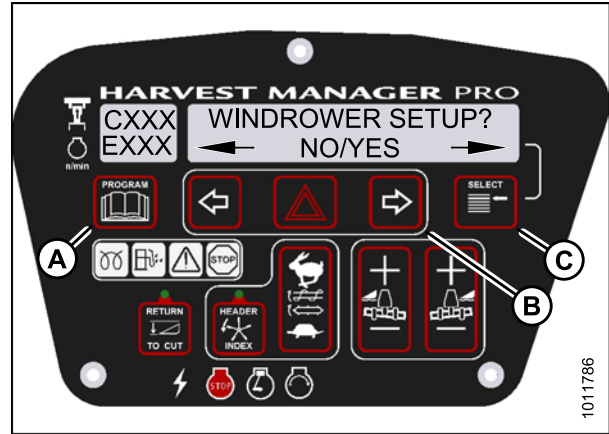

Figure 3.201: CDM Programming Buttons

3. Press SELECT (B) until DIAGNOSTIC MODE? is displayed in upper line.
  - NO/YES is displayed on the lower line.
4. Press right (A) arrow to select Yes. Press SELECT (B).

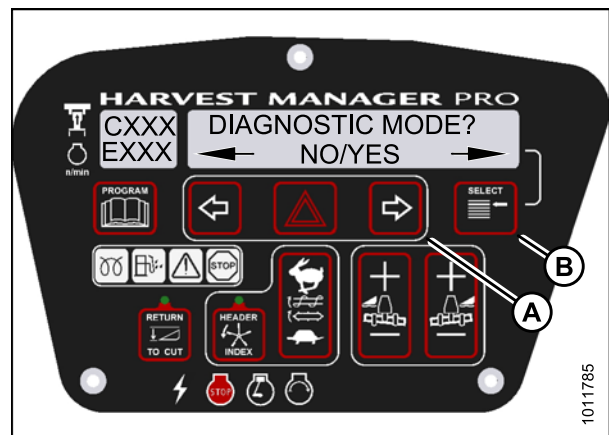

Figure 3.202: Diagnostic Functions

5. Press SELECT (B) until ACTIVATE FUNCTIONS? is displayed on the upper line.
  - NO/YES is displayed on the lower line.
6. Press right (A) arrow to select YES. Press SELECT (B).
  - ACTIVATE HEADER HT is displayed on the upper line.

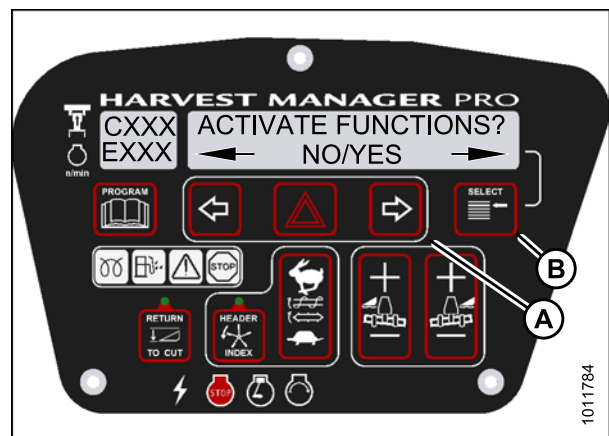

Figure 3.203: Functions

## OPERATOR'S STATION

### CAUTION

Check to be sure all bystanders have cleared the area.

- Press SELECT (E) until KNIFE DRIVE SPD XXXX is displayed on the upper line.

#### IMPORTANT:

Do **NOT** over speed the knife drive.

- Press and hold HAZARD (C) button.
  - Press left (B) arrow to **decrease** knife speed.
  - Press right (D) arrow to **increase** knife speed.

**Verify the knife drive is functioning properly.**

- Release the HAZARD (C) button. The knife will stop.
- Press PROGRAM (A) to exit Programming Mode or press SELECT (E) to proceed to next ACTIVATE FUNCTION.

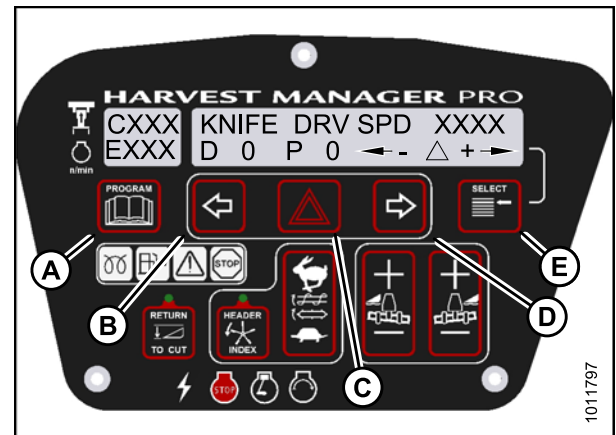

Figure 3.204: Knife Drive

### Testing the Draper Drive Circuit Activate Function Using the Cab Display Module (CDM)

#### IMPORTANT:

Do not over-speed a drive for a significant length of time. Doing so can lead to vibration, belt failures, or other over-speeding related problems.

#### NOTE:

- A draper header **MUST** be attached to windrower to follow this procedure. For more information, refer to [4.5 Attaching and Detaching Headers, page 214](#).
  - The engine **MUST** be running to perform this procedure.
- Turn ignition key to RUN, or start the engine.
  - Press PROGRAM (A) and SELECT (C) on cab display module (CDM) to enter Programming Mode.
    - WINDROWER SETUP? is displayed on the upper line.

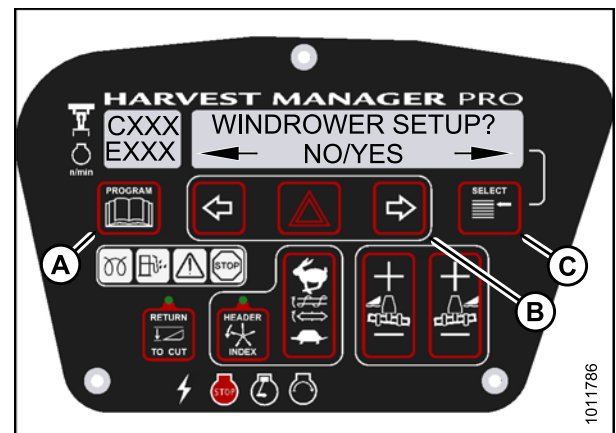

Figure 3.205: CDM Programming Buttons

## OPERATOR'S STATION

3. Press SELECT (B) until DIAGNOSTIC MODE? is displayed in upper line.
  - NO/YES is displayed on the lower line.
4. Press right (A) arrow to select Yes. Press SELECT (B).

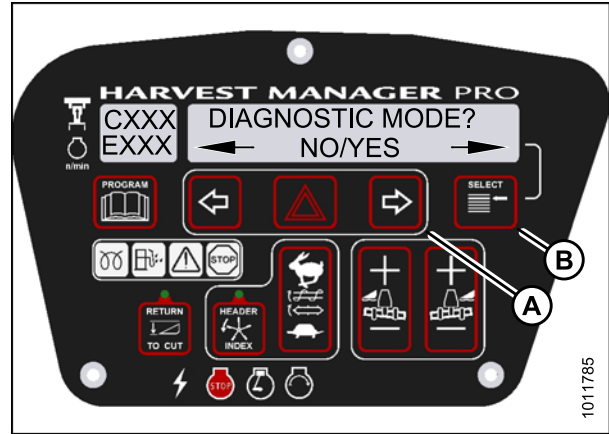

Figure 3.206: Diagnostic Functions

5. Press SELECT (B) until ACTIVATE FUNCTIONS? is displayed on the upper line.
  - NO/YES is displayed on the lower line.
6. Press right (A) arrow to select YES. Press SELECT (B).
  - ACTIVATE HEADER HT is displayed on the upper line.



Figure 3.207: Functions

### CAUTION

Check to be sure all bystanders have cleared the area.

7. Press SELECT (B) until DRAPER DRV SPD XXXX is displayed on the upper line.

#### IMPORTANT:

Do **NOT** over speed the drapers.

8. Press and hold HAZARD (C) button.
  - Press left (B) arrow to **decrease** draper speed.
  - Press right (D) arrow to **increase** draper speed.

**Verify the draper drive is functioning properly.**

9. Release the HAZARD (C) button. The drapers will stop.
10. Press PROGRAM (A) to exit Programming Mode or press SELECT (E) to proceed to next ACTIVATE FUNCTION.

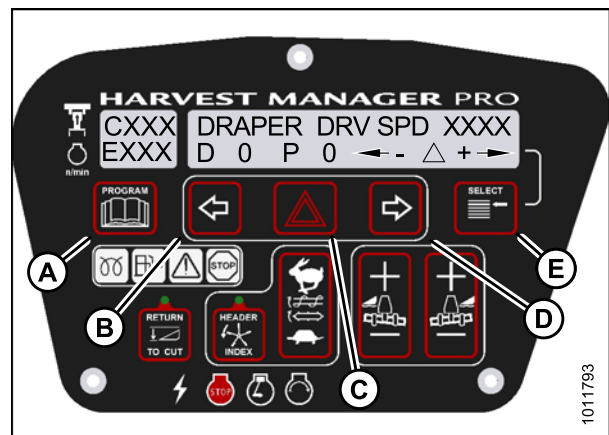

Figure 3.208: Draper Drive



## OPERATOR'S STATION

### Testing the Reel Drive Circuit Activate Function Using the Cab Display Module (CDM)

#### IMPORTANT:

Do not over-speed a drive for a significant length of time. Doing so can lead to vibration, belt failures, or other over-speeding related problems.

#### NOTE:

- The header **MUST** be attached to windrower to follow this procedure. For more information, refer to [4.5 Attaching and Detaching Headers, page 214](#).
- This procedure does not apply to rotary disc headers.
- The engine **MUST** be running to perform this procedure.

1. Turn ignition key to RUN, or start the engine.
2. Press PROGRAM (A) and SELECT (C) on cab display module (CDM) to enter Programming Mode.
  - WINDROWER SETUP? is displayed on the upper line.

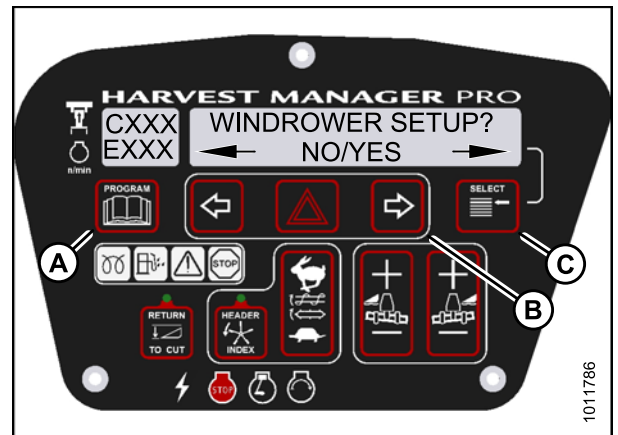

Figure 3.209: CDM Programming Buttons

3. Press SELECT (B) until DIAGNOSTIC MODE? is displayed in upper line.
  - NO/YES is displayed on the lower line.
4. Press right (A) arrow to select Yes. Press SELECT (B).

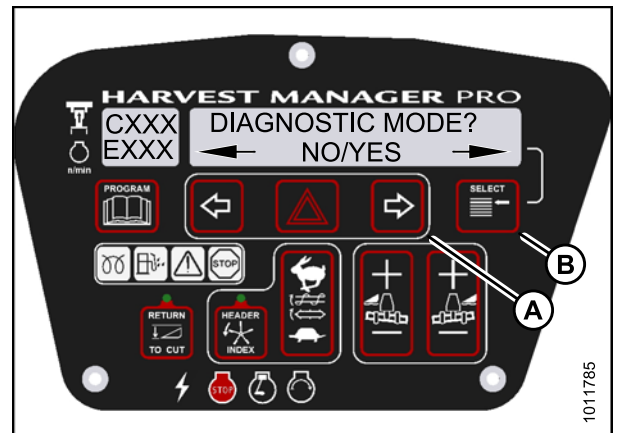

Figure 3.210: Diagnostic Functions

## OPERATOR'S STATION

5. Press SELECT (B) until ACTIVATE FUNCTIONS? is displayed on the upper line.
  - NO/YES is displayed on the lower line.
6. Press right (A) arrow to select YES. Press SELECT (B).
  - ACTIVATE HEADER HT is displayed on the upper line.



Figure 3.211: Functions

### CAUTION

Check to be sure all bystanders have cleared the area.

7. Press SELECT (E) until REEL DRV SPD XXXX is displayed on the upper line.

#### IMPORTANT:

Do **NOT** over speed the reel.

8. Press and hold HAZARD (C) button.
  - Press left (B) arrow to **decrease** reel speed.
  - Press right (D) arrow to **increase** reel speed.

**Verify the reel drive is functioning properly.**

9. Release the HAZARD (C) button. The reel will stop.
10. Press PROGRAM (A) to exit Programming Mode or press SELECT (E) to proceed to next ACTIVATE FUNCTION.

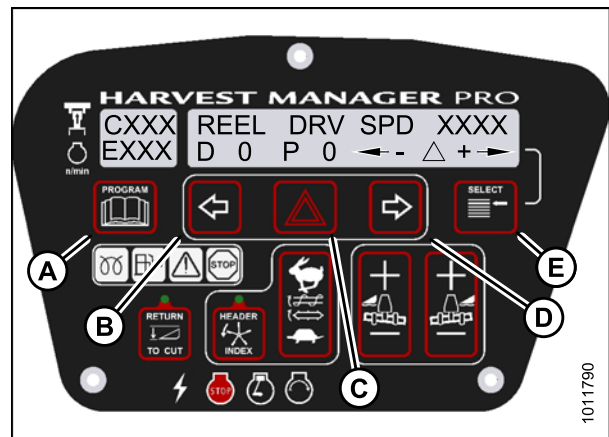

Figure 3.212: Reel Drive

### *Testing the Rotary Disc Drive Circuit Activate Function Using the Cab Display Module (CDM)*

#### IMPORTANT:

Do not over-speed a drive for a significant length of time. Doing so can lead to vibration, belt failures, or other over-speeding related problems.

#### NOTE:

- A rotary disc header **MUST** be attached to windrower to follow this procedure.
- The engine **MUST** be running to perform this procedure.

## OPERATOR'S STATION

1. Turn ignition key to RUN, or start the engine.
2. Press PROGRAM (A) and SELECT (C) on cab display module (CDM) to enter Programming Mode.
  - WINDROWER SETUP? is displayed on the upper line.

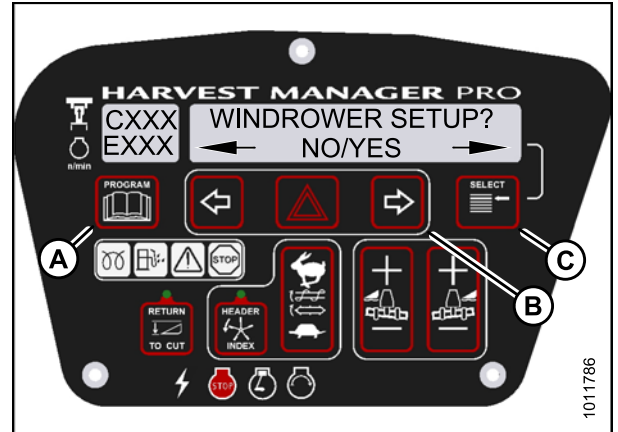

Figure 3.213: CDM Programming Buttons

3. Press SELECT (B) until DIAGNOSTIC MODE? is displayed in upper line.
  - NO/YES is displayed on the lower line.
4. Press right (A) arrow to select Yes. Press SELECT (B).

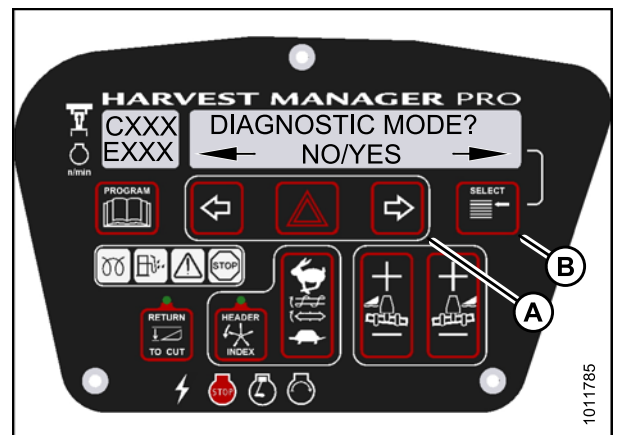

Figure 3.214: Diagnostic Functions

5. Press SELECT (B) until ACTIVATE FUNCTIONS? is displayed on the upper line.
  - NO/YES is displayed on the lower line.
6. Press right (A) arrow to select YES. Press SELECT (B).
  - ACTIVATE HEADER HT is displayed on the upper line.

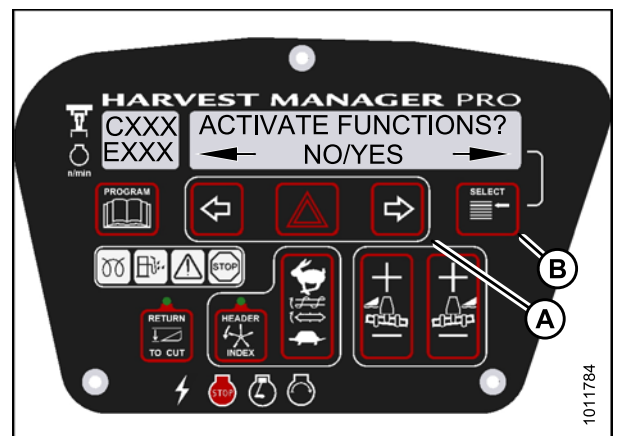

Figure 3.215: Functions

## OPERATOR'S STATION

### CAUTION

Check to be sure all bystanders have cleared the area.

7. Press SELECT (E) until DISC DRV SPD XXXX is displayed on the upper line.

#### IMPORTANT:

Do **NOT** over speed the disc drive.

8. Press and hold HAZARD (C) button.
  - Press left (B) arrow to **decrease** disc speed.
  - Press right (D) arrow to **increase** disc speed.

**Verify the disc drive is functioning properly.**

9. Release the HAZARD (C) button. The disc drive will stop.
10. Press PROGRAM to exit Programming Mode or press SELECT to proceed to next ACTIVATE FUNCTION.

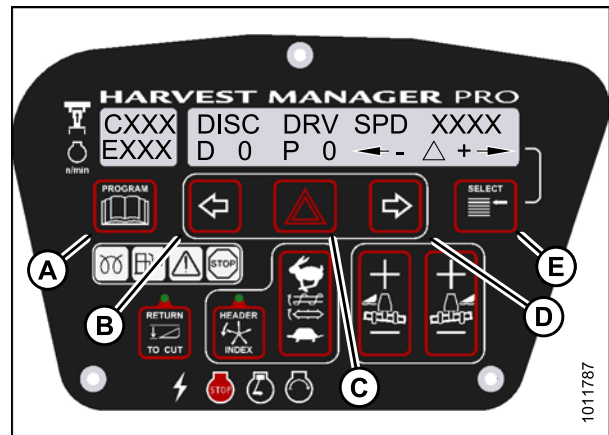

Figure 3.216: Disc Drive

### *Testing the Double Windrow Attachment (DWA) Drive Activate Function Using the Cab Display Module (CDM)*

#### IMPORTANT:

Do not over-speed a drive for a significant length of time. Doing so can lead to vibration, belt failures, or other over-speeding related problems.

#### NOTE:

- DWA must be attached to windrower and activated under the WINDROWER SETUP menu. For more information, refer to [Activating the Double Windrow Attachment \(DWA\)](#), page 113.
  - Engine **MUST** be running to perform this procedure.
1. Turn ignition key to RUN, or start the engine.
  2. Press PROGRAM (A) and SELECT (C) on cab display module (CDM) to enter Programming Mode. Press SELECT (C).
    - WINDROWER SETUP? is displayed on the upper line.

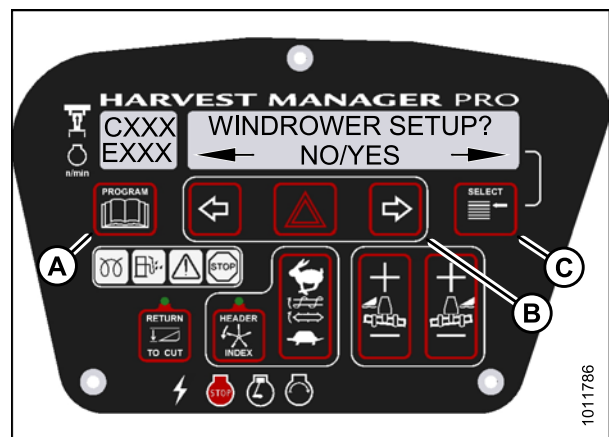

Figure 3.217: CDM Programming Buttons

## OPERATOR'S STATION

3. Press SELECT (B) until DIAGNOSTIC MODE? is displayed in upper line.
  - NO/YES is displayed on the lower line.
4. Press right (A) arrow to select Yes. Press SELECT (B).

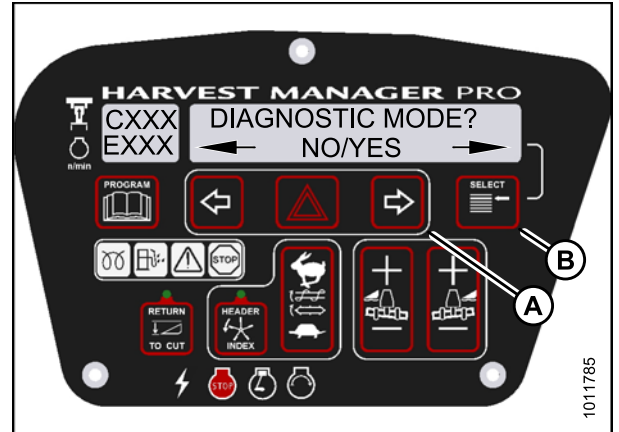

Figure 3.218: Diagnostic Functions

5. Press SELECT (B) until ACTIVATE FUNCTIONS? is displayed on the upper line.
  - NO/YES is displayed on the lower line.
6. Press right (A) arrow to select YES. Press SELECT (B).
  - ACTIVATE HEADER HT is displayed on the upper line.

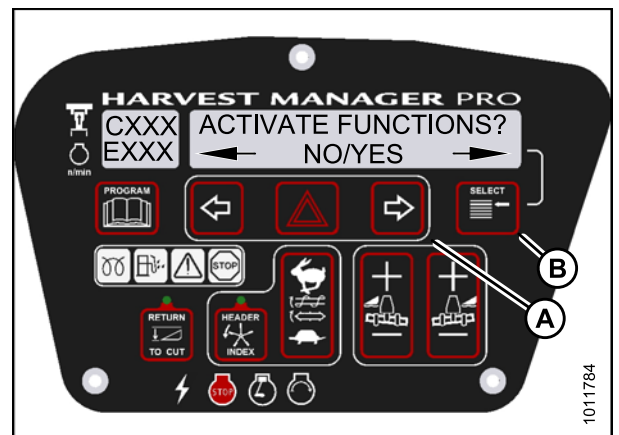

Figure 3.219: Functions

7. Press SELECT (E) until ACTIVATE DWA DRV is displayed on the upper line.

### CAUTION

Check to be sure all bystanders have cleared the area.

#### IMPORTANT:

Do **NOT** over speed the DWA drive.

8. Press and hold HAZARD (C) button.
  - Press left (B) arrow to decrease DWA drive speed.
  - Press right (D) arrow to increase DWA drive speed.

**Verify the DWA drive is functioning properly.**

9. Release the HAZARD (C) button. The DWA drive will stop.
10. Press PROGRAM (A) to exit Programming Mode or press SELECT (E) to proceed to next ACTIVATE FUNCTION.

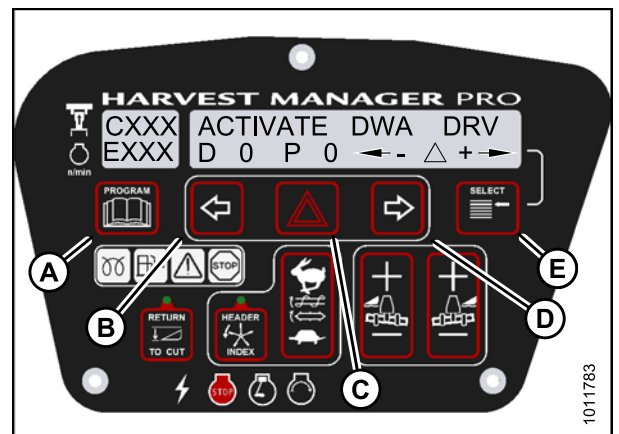

Figure 3.220: DWA Drive

### **3.19.14 Engine Error Codes**

The cab display module (CDM) displays error codes when there is a fault with one of the several sensors that monitor and control engine operation, to assist the Operator or Technician in locating a specific problem with engine operation. Refer to [8.4 Engine Error Codes, page 459](#).

### **3.19.15 Cab Display Module (CDM) and Windrower Control Module (WCM) Fault Codes**

The CDM displays fault codes when there is a fault with one of the sensors that monitor and control windrower operation, to assist the Operator or Technician in locating a specific problem with the windrower. Refer to [8.8.1 Cab Display Module \(CDM\) Error Codes, page 490](#).

## 4 Operation

### 4.1 Owner/Operator Responsibilities

#### CAUTION

- It is your responsibility to read and understand this manual completely before operating the windrower. Contact your Dealer if an instruction is not clear to you.
- Follow all safety messages in the manual and on safety signs on the machine.
- Remember that YOU are the key to safety. Good safety practices protect you and the people around you.
- Before allowing anyone to operate the windrower, for however short a time or distance, make sure they have been instructed in its safe and proper use.
- Review the manual and all safety related items with all Operators every year.
- Be alert for other Operators not using recommended procedures or not following safety precautions. Correct these mistakes immediately, before an accident occurs.
- Do NOT modify the machine. Unauthorized modifications may impair the function and/or safety and affect machine life.
- The safety information given in this manual does NOT replace safety codes, insurance needs, or laws governing your area. Be sure your machine meets the standards set by these regulations.

## 4.2 Symbol Definitions

The following symbols are used to depict functions or reactions at the various instruments and controls. Learn the meaning of these symbols before operating the windrower.

### 4.2.1 Engine Functions

These are the symbols that are used on the console.

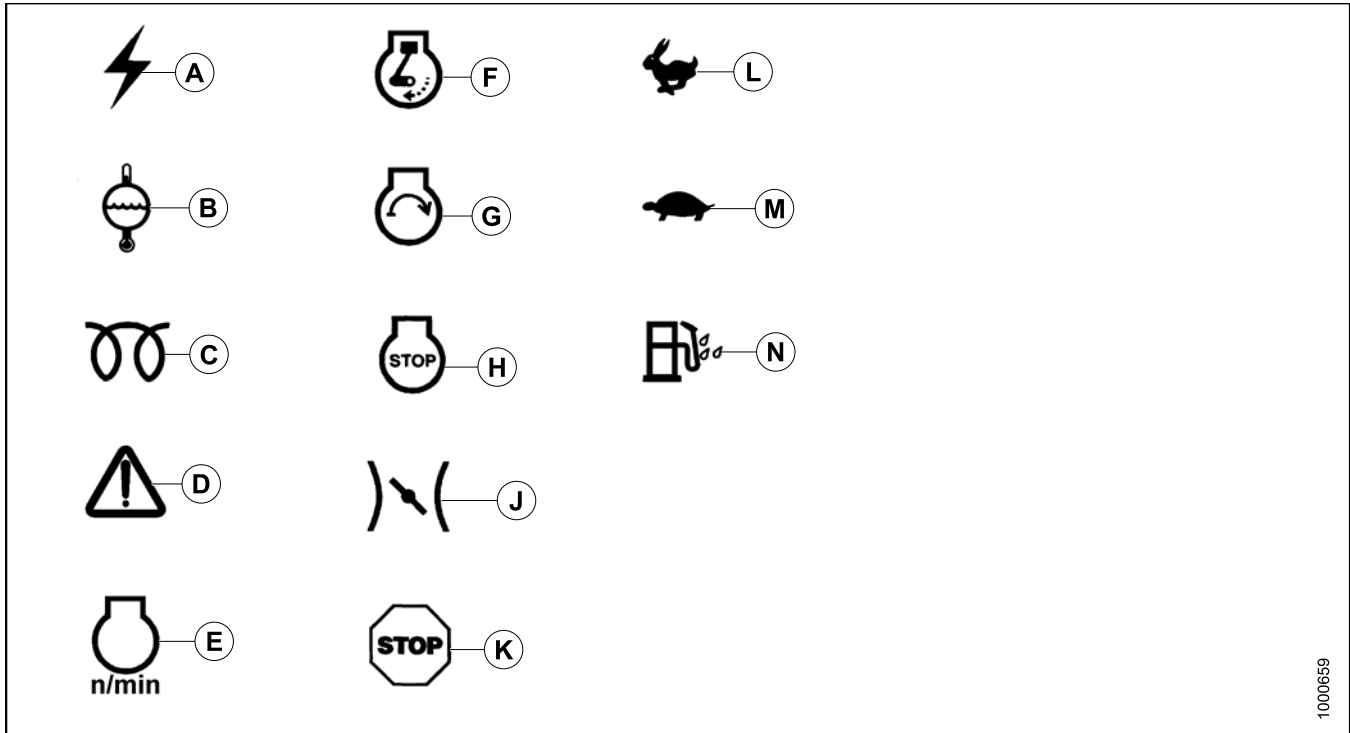

Figure 4.1: Engine Function Symbols

- |                                    |                                |                       |
|------------------------------------|--------------------------------|-----------------------|
| A - Electrical Power – Accessories | B - Engine Coolant Temperature | C - Engine Glow Plugs |
| D - Engine Malfunction             | E - Engine rpm                 | F - Engine Run        |
| G - Engine Start                   | H - Engine Stop                | J - Engine Throttle   |
| K - Engine Urgent Stop             | L - Fast                       | M - Slow              |
| N - Water in Fuel                  |                                |                       |



## 4.2.2 Diesel Exhaust Fluid (DEF) Display



**Figure 4.2: Fuel and Diesel Exhaust Fluid (DEF) Display Module**

A - Fuel and DEF Level

B - High Exhaust System Temperature (HEST)

C - Selective Catalytic Reduction (SCR) System  
Cleaning Inhibit

D - SCR System Cleaning Forced

Refer to [3.16.1 Fuel and Diesel Exhaust Fluid \(DEF\) Display Module, page 66](#) for operation and more information.

## OPERATION

### 4.2.3 Windrower Operating Symbols

These are the symbols used on the console for windrower operation.



**Figure 4.3: Windrower Operating Symbols**

- |                                    |                                   |                                |
|------------------------------------|-----------------------------------|--------------------------------|
| <b>A - Turn Signals</b>            | <b>B - Hazard Warning Lights</b>  | <b>C - Forward</b>             |
| <b>D - Neutral</b>                 | <b>E - Reverse</b>                | <b>F - Headlights Low Beam</b> |
| <b>G - Headlights High Beam</b>    | <b>H - Work Light</b>             | <b>J - Lighter</b>             |
| <b>K - Fresh Air</b>               | <b>L - Blower</b>                 | <b>M - Windshield Wiper</b>    |
| <b>N - Seat Height Up</b>          | <b>O - Seat Height Down</b>       | <b>P - Seat Fore and Aft</b>   |
| <b>Q - Seat Fore Aft Isolator</b>  | <b>R - Seat Back Fore and Aft</b> | <b>S - Seat Ride Damping</b>   |
| <b>T - Cab Temperature Control</b> | <b>U - Air Conditioning</b>       | <b>V - Recirculate</b>         |

### 4.2.4 Header Functions

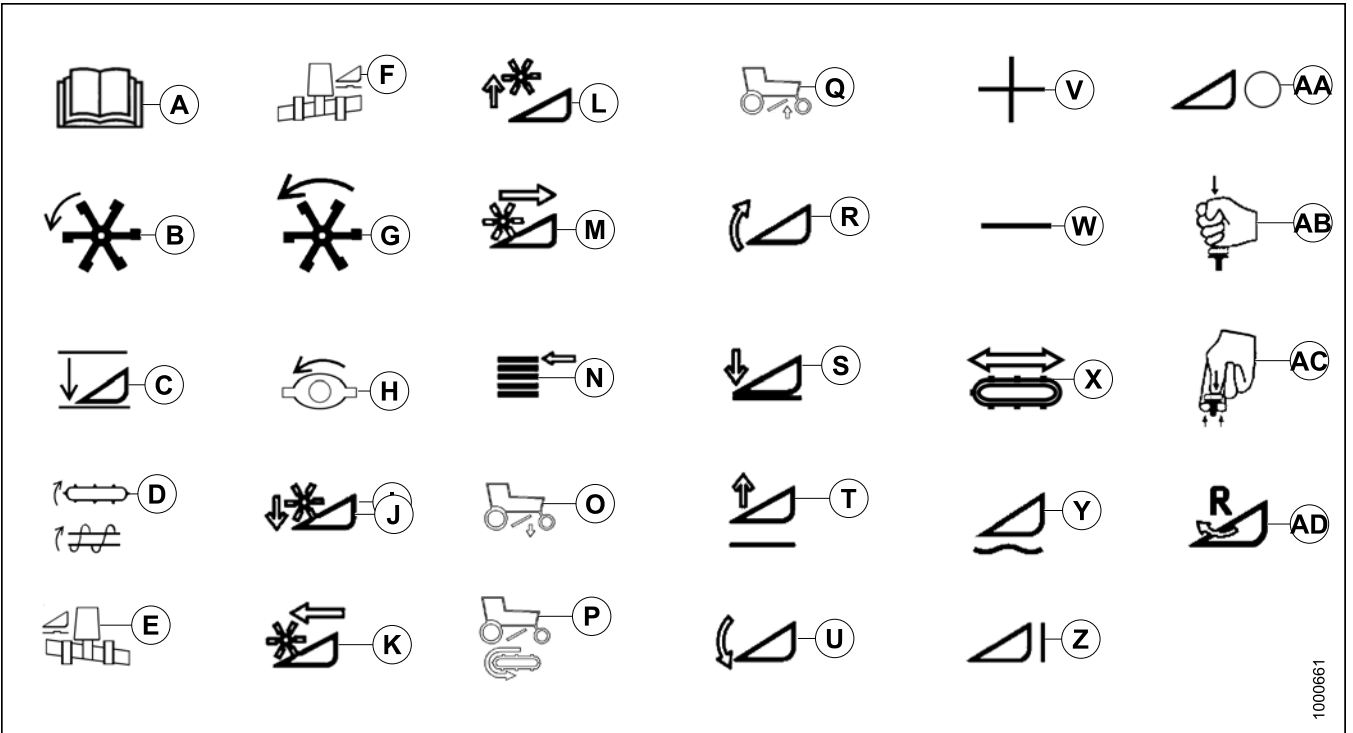

Figure 4.4: Header Function Symbols

- |                            |                       |                                 |
|----------------------------|-----------------------|---------------------------------|
| A - Program                | B - Header Index      | C - Return to Cut               |
| D - Conveyor/Auger Speed   | E - Float Left        | F - Float Right                 |
| G - Reel Speed             | H - Disc Speed        | J - Reel Down                   |
| K - Reel Forward           | L - Reel Up           | M - Reel Rearward               |
| N - Display Select         | O - DWA Down          | P - DWA Draper Speed            |
| Q - DWA Up                 | R - Header Tilt Up    | S - Header Down                 |
| T - Header Up              | U - Header Tilt Down  | V - Increase                    |
| W - Decrease               | X - Deck Shift        | Y - Float                       |
| Z - Header Engage          | AA - Header Disengage | AB - Push Down Header Disengage |
| AC - Pull Up Header Engage | AD - Header Reverse   |                                 |

## 4.3 Operating the Windrower

### 4.3.1 Operational Safety

#### CAUTION

Follow these safety precautions:

- Wear close fitting clothing and protective shoes with slip resistant soles.
- Remove foreign objects from the machine and surrounding area.
- Carry with you any protective clothing and personal safety devices that **COULD** be necessary through the day. Don't take chances.
- You may need:
  - a hard hat
  - protective glasses or goggles
  - heavy gloves
  - respirator or filter mask
  - wet weather gear

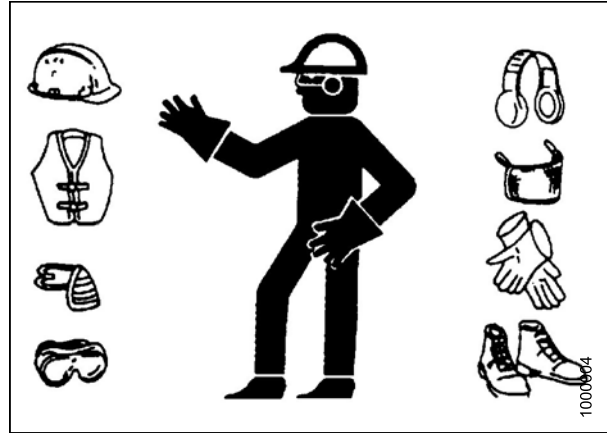

Figure 4.5: Safety Equipment

- Protect against noise. Wear a suitable hearing protective device such as ear muffs or ear plugs to protect against objectionable or uncomfortable loud noises.
- Follow all safety and operational instructions given in your operator's manuals. If you do not have a header manual, get one from your Dealer and read it thoroughly.
- Never attempt to start the engine or operate the machine except from the operator's seat
- Check the operation of all controls in a safe clear area before starting work.
- Check for excessive vibration and unusual noises. If there is any indication of trouble, shut down and inspect the machine. Follow proper shutdown procedure. Refer to [Shutting Down the Engine, page 166](#).
- Operate only in daylight or good artificial light.



Figure 4.6: Safety Equipment

### 4.3.2 Break-In Period

The windrower is ready for normal operation. However, there are several items to check and watch out for during the first 150 hours.

In addition to the following, check the items specified in [5.12.1 Maintenance Schedule/Record, page 414](#).

#### **DANGER**

**Before investigating an unusual sound or attempting to correct a problem, place ground speed lever (GSL) in N-DETENT, shut off engine, and remove key.**

#### **IMPORTANT:**

Until you become familiar with the sound and feel of your new windrower, be extra alert and attentive.

- Operate engine at moderate load and avoid extremely heavy or light loading for longer than five minutes.
- Avoid unnecessary idling. If engine will be idling longer than five minutes after reaching operating temperature, turn key OFF to stop engine.
- Check engine oil level frequently. Watch for any signs of leakage. If oil must be added, refer to [5.7.3 Checking Engine Oil Level, page 311](#).

#### **NOTE:**

During the break-in period, a higher than usual oil consumption should be considered normal.

#### **NOTE:**

If windrower must be driven in cold weather (below freezing), let engine idle for three minutes, and then operate at moderate speed until oil has warmed up.

- Watch coolant gauge in cab for temperature rising beyond normal operating range. Check that coolant level at reserve tank (mounted next to radiator) stays between HOT and COLD marks on tank. Refer to [5.7.9 Engine Cooling System, page 337](#). If over-heating problems occur, check for coolant leaks.

### 4.3.3 Preseason Checks/Annual Service

#### **CAUTION**

- **Review the operator's manual to refresh your memory on safety and operating recommendations.**
  - **Review all safety signs and other decals on the windrower and note hazard areas.**
  - **Be sure all shields and guards are properly installed and secured. Never alter or remove safety equipment.**
  - **Be sure you understand and have practiced safe use of all controls. Know the capacity and operating characteristics of the machine.**
  - **Store a properly stocked first aid kit and charged fire extinguisher on the windrower.**
1. Perform the following checks:
    - a. Drain off excess hydraulic oil added for storage. Refer to [5.10.3 Draining Hydraulic Oil, page 390](#).
    - b. Remove plastic bags and/or tape from all sealed openings (air cleaner intake, exhaust pipe, fuel tank).
    - c. Charge battery and install. Be sure terminals are clean and cables are connected securely.

## OPERATION

- d. Adjust tension on air conditioning (A/C) compressor belt. Refer to [Tensioning Air Conditioner \(A/C\) Compressor Belt, page 347](#).
  - e. Distribute A/C refrigerant by cycling A/C switch. Refer to [Air Conditioning Compressor Coolant Cycling, page 162](#).
  - f. Check the entire A/C system for leakage at the beginning of each season.
2. Perform annual maintenance. Refer to [5.12 Maintenance Schedule, page 414](#).

### Air Conditioning Compressor Coolant Cycling

#### IMPORTANT:

Perform the following steps whenever the machine is first started after storage for more than one week:

1. Turn blower switch (A) to the first position, turn temperature control switch (D) to maximum heating, and A/C control switch (B) to OFF.
2. Start engine, and operate at low idle until engine is warm.
3. Click A/C switch (B) from OFF to ON for one second, then back to OFF for 5–10 seconds. Repeat this step ten times.

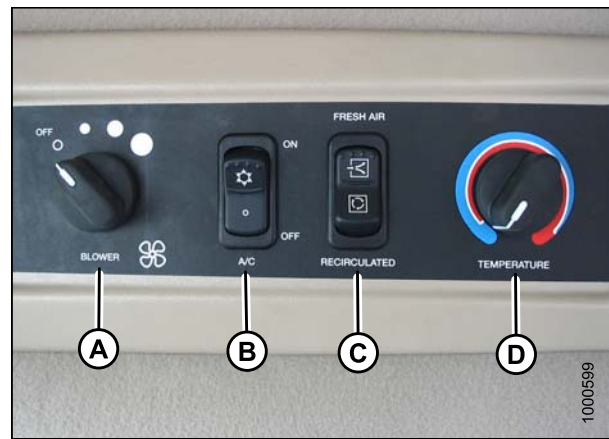

**Figure 4.7: Climate Control**

A - Blower Switch  
B - Air Conditioning Switch  
C - Outside Air Switch  
D - Temperature Control

### 4.3.4 Daily Checks and Maintenance

Perform the following checks and recommended maintenance before operating the windrower every day:

1. Check the machine for leaks.

#### NOTE:

Use proper procedure when searching for pressurized fluid leaks. Refer to [5.10.7 Hoses and Lines, page 399](#).

2. Check for missing or broken parts.
3. Clean the windows and mirrors to ensure good visibility in all directions. Stand on the platform to access the rear window. Hold onto the handholds on the cab front corners and stand on the header anti-slip strips to wash the front window.
4. Clean all lights and reflective surfaces to maintain visibility to others.
5. Perform daily maintenance. Refer to [5.12 Maintenance Schedule, page 414](#).

### 4.3.5 Engine Operation

#### *Starting the Engine*

#### **⚠ DANGER**

- Avoid possible injury or death from a runaway machine.
- This machine has safety devices which allow the engine to start only when the ground speed lever is in N-DETENT, the steering wheel is locked in the NEUTRAL position, and the header drive switch is in the OFF position. Under no circumstances are these devices to be deliberately rewired or misadjusted so that the engine can be started with controls out of NEUTRAL.
- Do NOT start engine by shorting across starter or starter relay terminals. Machine will start with drive engaged and move if normal starting circuitry is bypassed.
- Start engine only from operator's seat with controls in NEUTRAL. NEVER start engine while standing on ground. Never try to start engine with someone under or near machine.
- Before starting engine, be sure there is plenty of ventilation to avoid asphyxiation.

#### **IMPORTANT:**

Do NOT tow machine to start engine. Damage to hydrostatic drives will result.

#### **⚠ WARNING**

Before starting engine, securely fasten your seat belt and ensure trainer's seat belt is used if seat is occupied. The seat belt can help ensure your safety if it is used and maintained.

1. The battery main disconnect switch is located on the right-hand frame rail, behind the maintenance platform, and can be accessed by moving the platform. Ensure switch is in the POWER ON position.

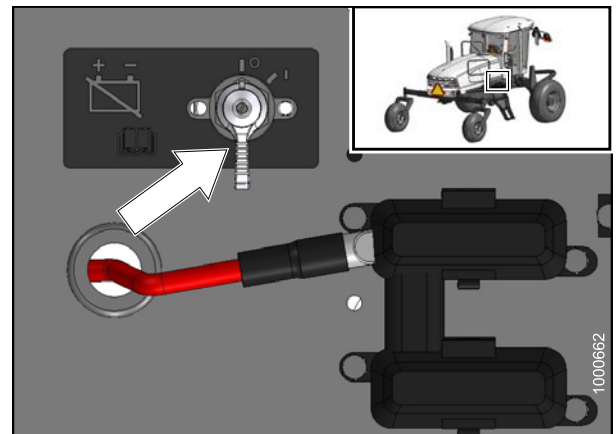

Figure 4.8: Battery Disconnect Switch

## OPERATION

2. Ensure lock (A) at the base of the steering column is engaged at cab-forward or engine-forward position.
3. Move ground speed lever (GSL) (B) into N-DETENT.
4. Turn steering wheel until it locks. It may be possible to move the steering wheel slightly in the locked position.

### IMPORTANT:

Do **NOT** attempt to force the wheel out of locked position as damage to the traction system may occur.

5. Fasten seat belt.
6. Push HEADER DRIVE switch (C) to ensure it is OFF.

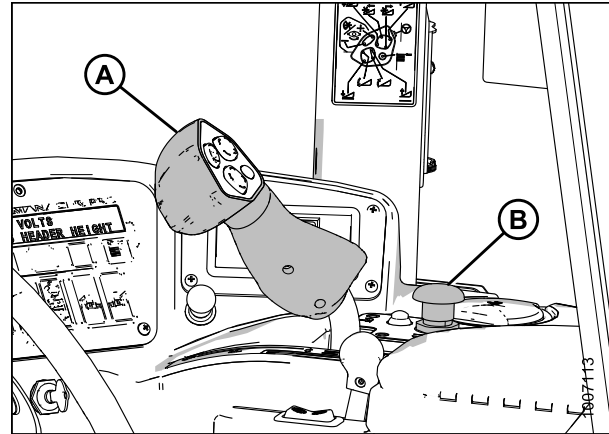

Figure 4.9: Operator Controls

### Normal Start

Engine temperature above 60°F (16°C):

### WARNING

If starter engages with steering wheel unlocked, ground speed lever out of NEUTRAL, or header clutch engaged, **DO NOT START ENGINE**. See your Dealer.

1. Set throttle (A) to START position—fully back.

### IMPORTANT:

The cab display module (CDM) provide important information about machine operation and condition. Familiarize yourself with the CDM's information screen. Refer to [3.19 Cab Display Module \(CDM\)](#), page 79.

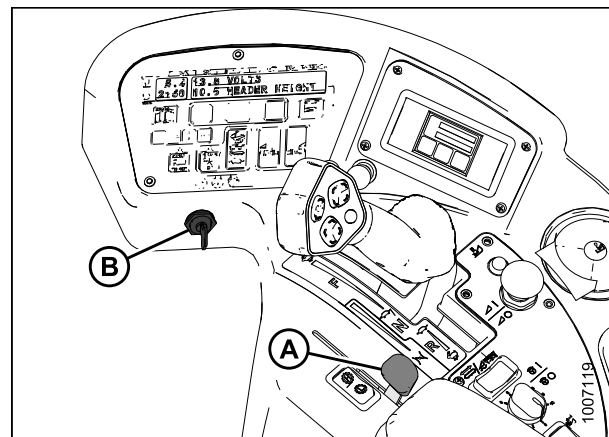

Figure 4.10: Operator Console

### CAUTION

Check to be sure all bystanders have cleared the area.

2. Sound horn three times.
3. Turn ignition key (B) to RUN position. Single loud tone sounds, engine warning lights illuminate as a self-test, and cab display module (CDM) displays HEADER DISENGAGED and IN PARK.
4. Turn ignition key (B) to START position until engine starts, and then release key. CDM displays programmed header data for five seconds if attached, and then returns to previous display.



## OPERATION

### IMPORTANT:

- Do **NOT** operate starter for longer than 15 seconds at a time.
- If engine does not start, wait at least two minutes before trying again.
- After the third 15 second crank attempt, allow solenoid to cool for 10 minutes before further cranking attempts. If engine still does not start, refer to [Engine Troubleshooting](#).

### Cold Start

Engine temperature below 40°F (5°C)

### WARNING

If starter engages with steering wheel unlocked, ground speed lever (GSL) out of NEUTRAL, or header clutch engaged, **DO NOT START ENGINE**. See your Dealer.

1. Set throttle (A) to START position - fully back (low idle).
2. Turn ignition key (B) to RUN.
3. Grid heater light (C) on CDM will cycle ON / OFF / ON after two seconds for a preset length of time. The operating period for the glow plug light will change depending engine temperature.
4. Sound horn three times.
5. When grid heater light (C) goes out, turn ignition key to START, and crank engine until it starts. Leave throttle (A) at IDLE.
6. If engine fails to start, repeat procedure beginning with Step 2., [page 165](#).
7. Engine will cycle through a period where it appears to labour.

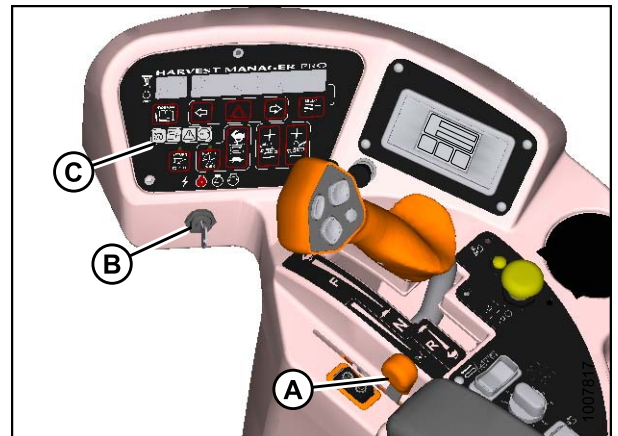

Figure 4.11: Operator Controls

### IMPORTANT:

Do **NOT** operate engine above 1500 rpm until engine temperature gauge is above 100°F (40°C).

### Engine Warmup

Allow engine to run with throttle lever (A) at or near low idle position until temperature reaches approximately 100°F (40°C).

### NOTE:

Scroll through cab display module (CDM) for engine temperature.



Figure 4.12: Operator Console

## OPERATION

### *Engine Intermediate Speed Control (ISC)*

The engine operating speed can be programmed to enable the windrower to operate at reduced engine rpm (that is, 1900, 2050, or 2200 rpm) without significantly affecting the ground or header speeds. The default setting is 2200 rpm or the last selected rpm.

Engine ISC is useful when operating loads are reduced such as in light crop conditions that do not require the maximum engine rpm. Reduced engine speed lowers fuel consumption, noise levels, and exhaust emissions in addition to reducing engine wear.

The programmed engine speed is activated when the header is engaged.

Programming instructions are provided in [3.19.6 Cab Display Module \(CDM\) Programming, page 93](#).

### *Shutting Down the Engine*

#### CAUTION

**Park on a flat, level surface with the header on the ground and the ground speed lever in N-DETENT position with the steering wheel locked.**

#### **IMPORTANT:**

Before stopping engine, run at low idle for approximately five minutes to cool hot engine parts (and allow turbocharger to slow down while engine oil pressure is available).

1. Lower header.
2. Place ground speed lever (GSL ) (B) into N-DETENT.
3. Lock steering wheel.
4. Turn ignition key (A) counterclockwise to OFF position.

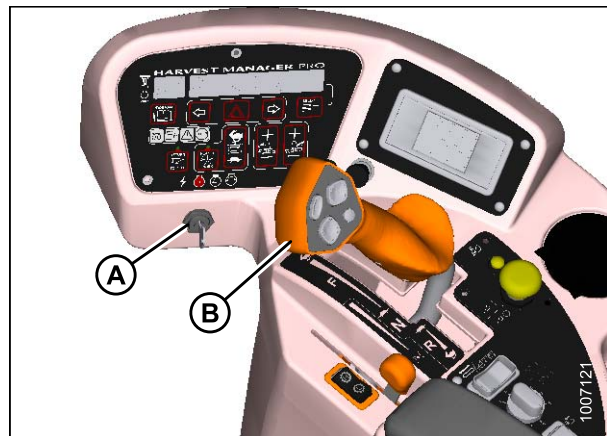

**Figure 4.13: Operator Console**

## OPERATION

### Engine Temperature

The engine temperature is displayed on the cab display module (CDM) (A) when selected with the SELECT button (B) on the ground speed lever (GSL) handle or the SELECT switch (C) on the CDM.

The normal engine operating temperature range is 180–220°F (82–104°C).

If the temperature exceeds 220°F (104°C), an ongoing intermittent tone will be heard and the CDM (A) will flash ENGINE TEMP. Stop the engine immediately and determine cause. The tone will stop and the CDM (A) will return to normal when the temperature drops below 215°F (102°C).

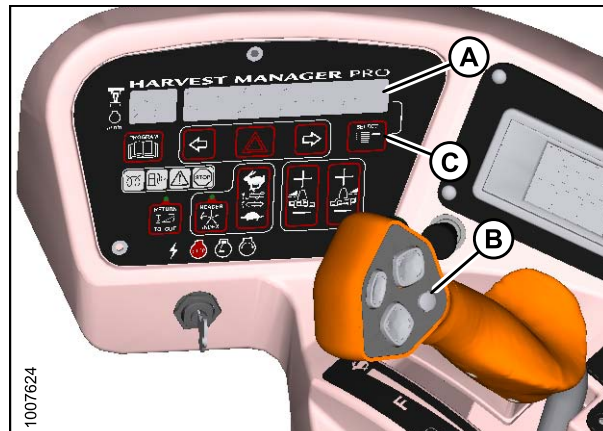

Figure 4.14: Operator Console

### Engine Oil Pressure

The nominal engine oil pressure is 10 psi (69 kPa) at low idle and 55.1 psi (380 kPa) at maximum rated speed.

If the oil pressure drops below the preset level of 7.5 psi (52 kPa), the cab display module (CDM) flashes an error code and error message.

If the STOP ENGINE light illuminates, stop the engine **IMMEDIATELY** and investigate.

If the yellow CAUTION light illuminates, stopping immediately is optional. You may continue operations and investigate later, but you are **STRONGLY** advised to monitor the situation carefully.

### Electrical

The electrical system voltage is displayed on the cab display module (CDM) when selected with the SELECT button on the ground speed lever (GSL) handle or the SELECT switch on the CDM. The display indicates the condition of the battery and alternator.

Ignition	Engine	Reading	Indicated Condition
ON	Running	13.8–15.0	Normal
		> 16.0 <sup>15</sup>	Regulator out of adjustment
		< 12.5 <sup>15</sup>	Alternator not working or regulator out of adjustment
	Shut down	12.0	Battery normal

### Engine Warning Lights

There are four engine warning lights that illuminate if abnormal conditions occur while the engine is running. The engine warning lights should **NOT** be illuminated under normal operating conditions. For more information, refer to [Engine Warning Lights, page 89](#).

---

15. Display flashes voltage reading with single loud tone. Repeats every 30 minutes until condition is fixed.

### 4.3.6 Diesel Exhaust Fluid (DEF)

DEF is a reactant injected into the exhaust system for fuel efficiency and exhaust emission improvement.

#### *Filling the Diesel Exhaust Fluid (DEF) Tank*

The low level warning light on the fuel and DEF display module will signal the Operator when DEF level is low. Refer to [3.16.1 Fuel and Diesel Exhaust Fluid \(DEF\) Display Module, page 66](#).

#### **⚠ DANGER**

**To avoid bodily injury or death from unexpected startup of the machine, always stop the engine and remove the key from the ignition before leaving the operator's seat for any reason.**

1. Stop windrower and remove key.
2. Open the maintenance platform on right cab-forward side. Refer to [5.3.3 Opening Platforms \(Major Service Position\), page 289](#).
3. Clean around filler cap (A).
4. Turn cap (A) counterclockwise until loose and remove cap.

**NOTE:**

Filler cap for DEF tank is blue and the nozzle dispenser is smaller compared to the fuel tank.

#### **⚠ CAUTION**

**Avoid contact with eyes. In case of contact, rinse immediately with water for 15 minutes.**

5. Fill tank with approved DEF. Refer to [8.1.3 Lubricants, Fluids, and System Capacities, page 444](#).

**IMPORTANT:**

DEF is corrosive. If spilled, DEF must be contained and absorbed by non-combustible absorbent material like sand and then shovelled into a suitable container for disposal. If spilled on tank or any surface of the vehicle, rinse thoroughly with water.

6. Replace filler cap (A) and turn clockwise until tight.
7. Close the maintenance platform. Refer to [5.3.4 Closing Platforms \(Major Service Position\), page 290](#).

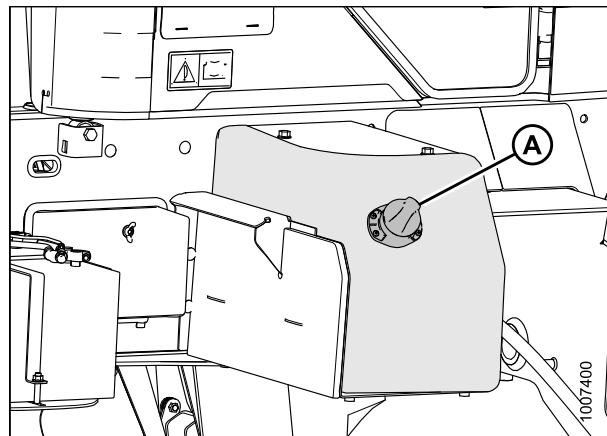

**Figure 4.15: DEF Tank**

### 4.3.7 Driving the Windrower

#### WARNING

The seat belts can help ensure your safety if it is used and maintained.

- Before starting the engine, securely fasten your seat belt. Ensure that anyone occupying the trainee's seat is secured by a seat belt as well.
- Never wear a seat belt loosely or with slack in the belt system. Never wear the belt in a twisted condition or pinched between the seat structural members.

#### WARNING

- Avoid driving the machine with header removed. Removing header decreases the weight on drive wheels, reducing steering control.
- If it is necessary to drive machine with header removed, use transmission field speed range, do NOT exceed 1500 rpm engine speed, and avoid loose gravel and slopes.
- Never use windrower as a towing vehicle when header is removed, except as instructed in [Towing Header with Windrower, page 182](#). There is insufficient weight on the drive wheels to provide steering control.
- Because of windrower shape characteristics, a roll-over protected (ROPS) cab is not required. If operating with header removed, be aware that cab structure will NOT withstand a roll-over.

#### CAUTION

##### HYDROSTATIC STEERING

- Turning the steering wheel varies the hydraulic flow to one drive wheel relative to the other drive wheel.
- The reaction of this type of steering is different from conventional steering mechanisms.

#### CAUTION

- With the engine running, moving the ground speed lever out of N-DETENT unlocks steering. Any movement of steering wheel will then cause the machine to move, even if the ground speed lever has not been moved forward or rearward from the NEUTRAL position.
- Hydrostatic steering is more sensitive than mechanical steering.
- Steering is opposite to normal when driving in reverse.
- The brakes are only on when the ground speed lever (GSL) is in N-DETENT and the steering wheel is centered and locked.

## OPERATION

### **DANGER**

- NEVER move the ground speed lever or steering wheel until you are sure all bystanders have cleared the area.
- Make sure area is clear before making turns, as the ends of a header travel in a large arc.
- Check the operation of all controls in a safe, clear area before starting work.
- Do know the capacity and operating characteristics of your machine.
- Do NOT allow riders in or on the machine.
- Do NOT operate unless seated in the operator's position.
- Do NOT attempt to get on or off a moving windrower.
- AVOID sudden starts and stops.
- AVOID inclines, ditches, and fences.
- Do NOT rapidly accelerate or decelerate when turning.
- REDUCE your speed before turning, crossing slopes, or travelling over rough ground.
- Do NOT allow anyone to stand behind the machine while operating. Foreign objects may be forcibly ejected.

#### *Entering and Exiting the Windrower*

### **CAUTION**

To provide more secure hand and foot mobility, preventing slipping and possible injury, ALWAYS face the windrower and use the hand rail when dismounting (or mounting). NEVER attempt to get on or off a moving windrower.

Before leaving the operator's seat for any reason:

- Park on level ground if possible.
- Be sure ground speed lever is in N-DETENT and steering wheel is locked in the straight-ahead position.
- Fully lower header and reel.
- Disengage header drives.
- To avoid bodily injury or death from unexpected startup of machine, always stop engine and remove key from ignition.
- Turn off wipers.
- Turn off lights unless required for inspection purposes.
- Release seat belt.
- Raise armrest and steering wheel for easier exit and re-entry.
- Lock the cab door when leaving the windrower unattended. (When the door is locked, it can still be opened from inside the cab.)

## OPERATION

Swing-away platforms and stairs (A) are provided on both sides of the windrower to accommodate cab-forward and engine-forward access to the operator's station, as well as several maintenance tasks.

The left cab-forward side platform is shown in the rearward (cab-forward) position.

Two doors (B) are provided for cab entry and exit in either cab-forward mode or engine-forward mode. Enter the cab using the door opposite the operator's console.

### NOTE:

When the engine is shut down, rear field lights turn on for 60 seconds to illuminate the platform and stairs.

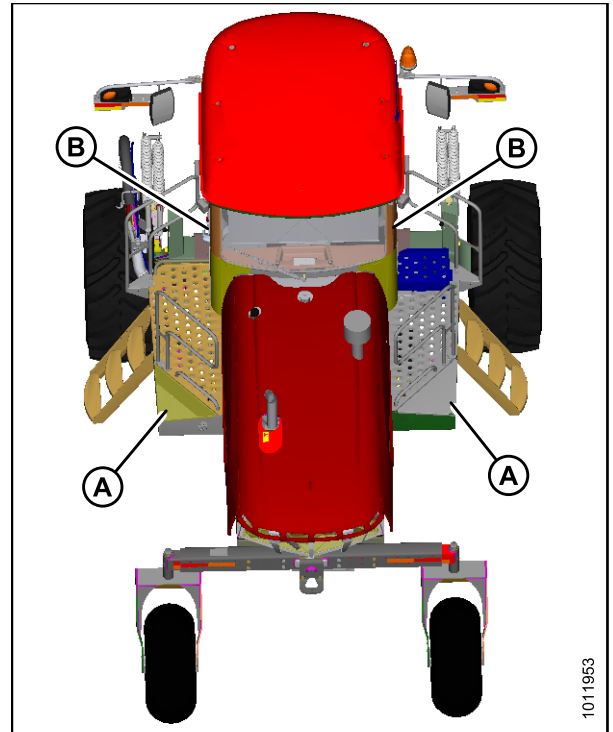

Figure 4.16: Platforms and Doors

### *Driving Forward in Cab-Forward Mode*

#### CAUTION

Operate both steering wheel and ground speed lever slowly for familiarization. Avoid the common tendency of new Operators to oversteer.

#### WARNING

Do NOT drive windrower on road in cab-forward configuration, unless it is equipped with the proper lighting and markings for cab-forward road travel.

In cab-forward mode, the Operator's station is facing away from the engine. If necessary, swivel operator's seat to cab-forward position as follows:

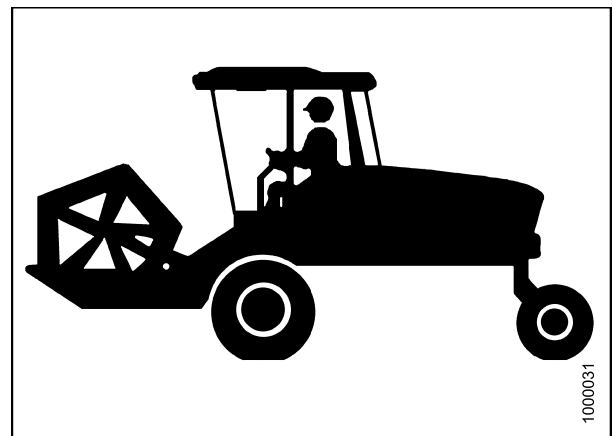

Figure 4.17: Cab-Forward Mode

## OPERATION

1. Place ground speed lever (GSL) (A) in N-DETENT. Engine can be running.

### IMPORTANT:

If GSL is NOT in N-DETENT, damage to the GSL cable may result when swivelling operator's station.

2. Pull up on knob (B) and hold to release latch (C) at base of steering column.
3. Turn steering wheel counterclockwise to pivot operator's station clockwise 180° until pin engages latch to secure operator's station in new position.
4. Ensure seat belt is fastened.
5. Start engine if not running. Refer to [Starting the Engine, page 163](#).
6. There are two cab-forward speed ranges. Set ground speed range switch (A) to either **H** (0–16 mph [25.7 km/h]), or **L** (0–11 mph [17.7 km/h]).
7. Slowly push throttle (B) to full forward (operating speed). cab display module (CDM) should display 2320–2350 rpm at (C).

### CAUTION

Check again to be sure all bystanders have cleared the area.

8. Move the GSL (E) out of N-DETENT and slowly forward to desired speed which will be displayed at (D).

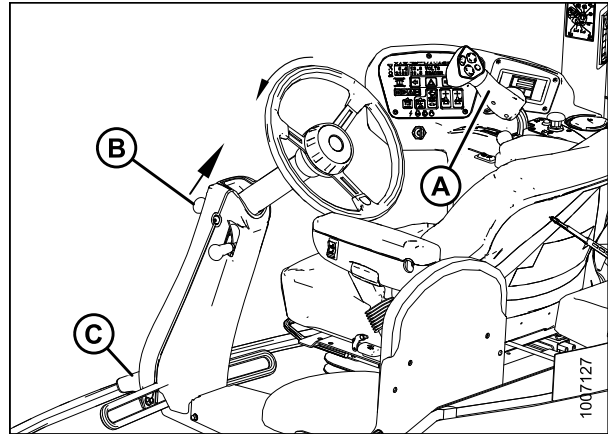

Figure 4.18: Operator Console

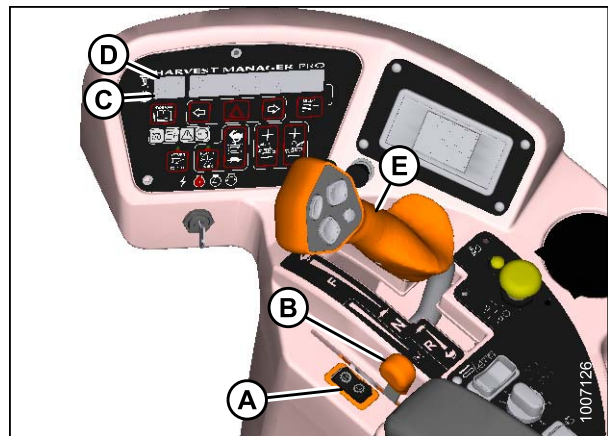

Figure 4.19: Operator Console

### NOTE:

The windrower can be equipped with an automatic steering system for use in the field. An automated steering system is available as an option and can be installed by a MacDon Dealer. The GSL has been pre-wired at the factory with a switch. Refer to [6.1.4 Automated Steering Systems, page 419](#).

### *Driving Reverse in Cab-Forward Mode*

### WARNING

Back up slowly. Steering is opposite to normal when reversing. Hold steering wheel at the bottom and turn wheel in direction you want the rear (cab-forward) of the machine to travel.



## OPERATION

1. Move speed range switch (A) to L (low-range position).
2. Move throttle lever (B) to a mid-range position.

**NOTE:**

Reversing in low speed range and at reduced engine speed is recommended since steering will be less sensitive than at higher speed settings.

**CAUTION**

Check again to be sure all bystanders have cleared the area.

3. Move the ground speed lever (GSL) rearward to desired speed.
4. Steer as shown.

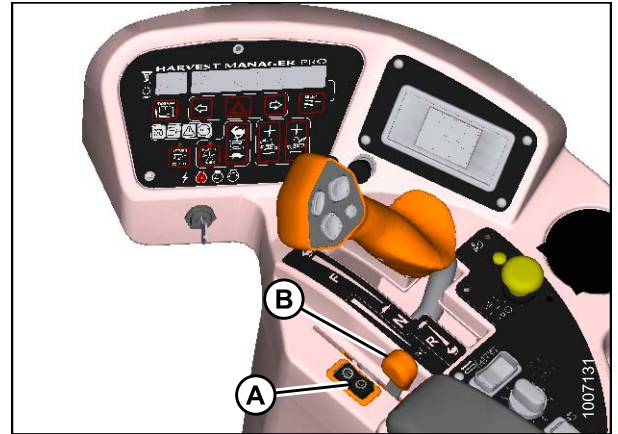

Figure 4.20: Operator's Console

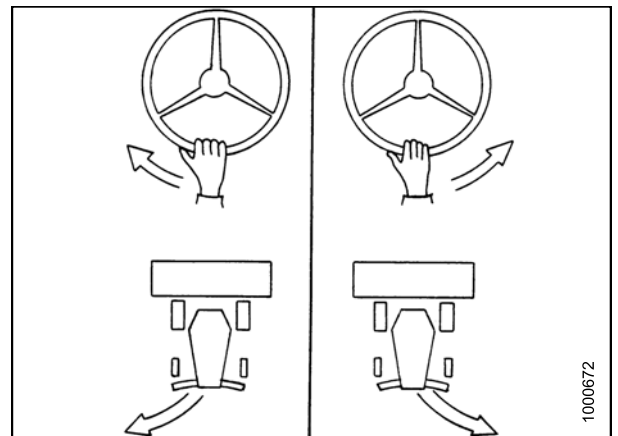

Figure 4.21: Cab-Forward Mode

### *Driving Forward in Engine-Forward Mode*

In the engine-forward mode, the Operator's station is facing toward the engine. If necessary, swivel operator's station to engine-forward position as follows:



Figure 4.22: Engine-Forward – Seat Faces Engine

## OPERATION

1. Place ground speed lever (GSL) (A) in N-DETENT and lock steering wheel. Engine can be running.

### IMPORTANT:

If GSL is **NOT** in N-DETENT, damage to the GSL cable may result when swivelling operator's station.

2. Pull up on knob (B) and hold to release latch (C) at base of steering column.
3. Turn steering wheel clockwise to pivot operator's station counterclockwise 180° until pin engages latch to secure operator's station in new position.
4. Start engine if not running.

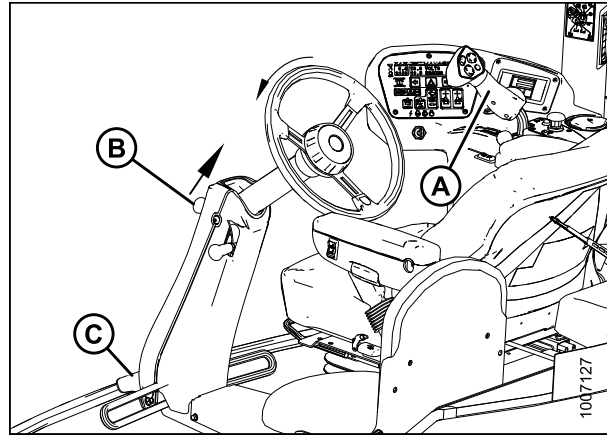

Figure 4.23: Engine-Forward – Seat Faces Engine

5. Set ground speed range switch (A) to **H** for road speed (0–23 mph [37 km/h]). Cab display module (CDM) will display ROAD GEAR at (F) and an alarm will briefly sound.
6. Slowly push throttle (B) to full forward (operating speed). CDM should display 2320–2350 rpm at (C).

### CAUTION

Check to be sure all bystanders have cleared the area.

7. Slowly move the GSL (E) forward to desired speed which will be displayed at (D).

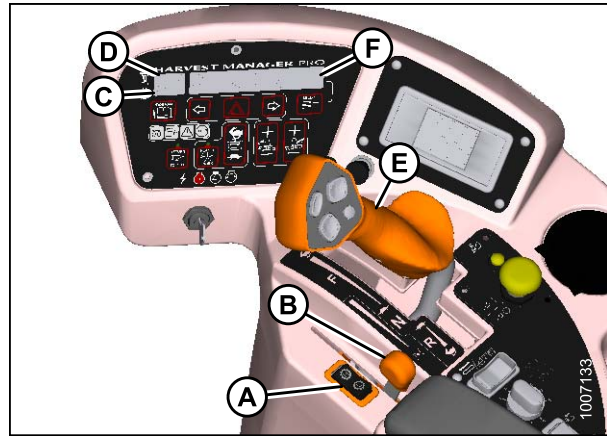

Figure 4.24: Operator Console

## CAUTION

Operate both steering wheel and ground speed lever slowly while becoming familiar with the machine. Remember that steering is more sensitive when speed-range control is in road speed position. Avoid the common tendency of new Operators to oversteer.

8. If more tractive (lugging) power is required (for example, when driving up a ramp, up a hill, or up out of a ditch):
  - a. Move the GSL (E) closer to NEUTRAL.
  - b. Switch speed-range control (B) to **L** (low range).
9. Once the lugging condition no longer exists:
  - a. Set GSL (E) to **NOT MORE THAN HALF** maximum forward speed.
  - b. Move speed-range control (B) to **H** (high-range). Steering is more sensitive in this speed range.

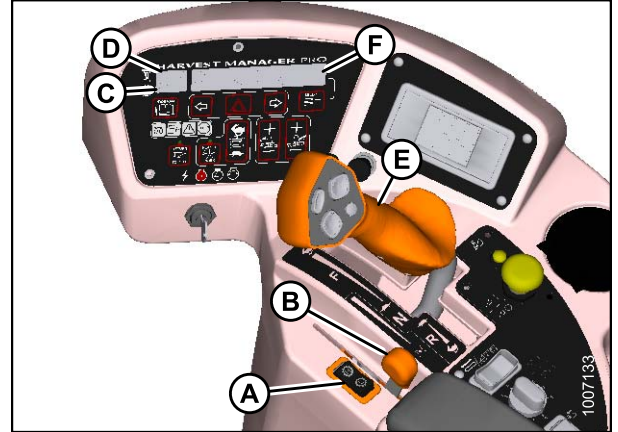

Figure 4.25: Operator Console

### *Driving in Reverse in Engine-Forward Mode*

## WARNING

Back up slowly. Steering is opposite to normal when reversing. Hold steering wheel at the bottom and turn wheel in direction you want the rear (cab-forward) of the machine to travel.

1. Move speed-range switch (A) to **L** (low-range position).
2. Move throttle lever (B) to a mid-range position.

### NOTE:

Reversing in low speed range and at reduced engine speed is recommended since steering will be less sensitive than at higher speed settings.

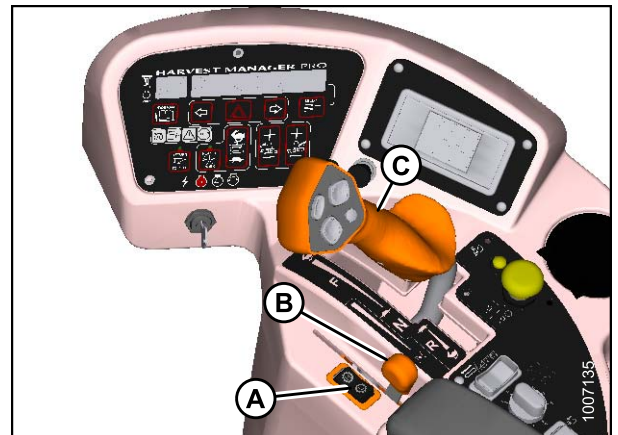

Figure 4.26: Operator Console

## OPERATION

### CAUTION

Check to be sure all bystanders have cleared the area.

3. Move the ground speed lever (GSL) (C) rearward to desired speed.
4. Steer as shown.

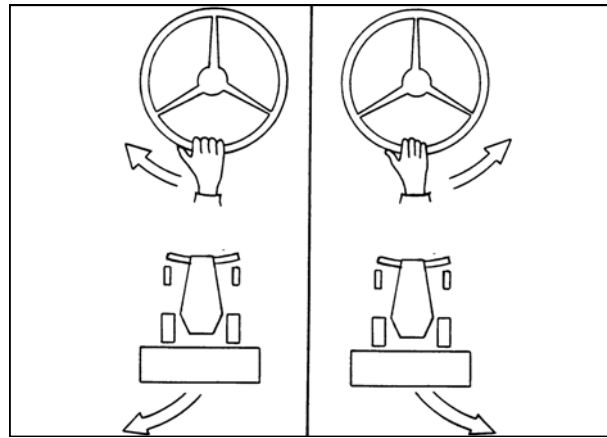

Figure 4.27: Steering the Windrower

### *Spin Turning*

Hydrostatic steering provides significantly more manoeuvrability than mechanical steering.

### CAUTION

Be sure area is clear before making turns. Although windrower pivots on the spot, the ends of the header travel faster and in a large arc.

1. Move the ground speed lever (GSL) (A) out of N-DETENT towards the seat and hold.
2. Slowly turn the steering wheel in the desired direction of turn. The windrower will pivot between the drive wheels.
3. To increase the turn radius, slowly move the GSL away from NEUTRAL. Remember that this will increase ground speed as well.
4. To stop the turn, slowly turn the steering wheel back to its centered position.



Figure 4.28: Operator Console

### *Stopping*

### WARNING

Do NOT move ground speed lever rapidly back to NEUTRAL. You may be thrown forward by sudden stop. Always wear seat belt when operating windrower.

To stop the windrower:

## OPERATION

1. **SLOWLY** return the ground speed lever (GSL) (A) to NEUTRAL and into N-DETENT.
2. Turn steering wheel until it locks.
3. Move throttle lever (B) to low idle position.

**NOTE:**

Avoid unnecessary idling. Stop engine if it will be idling for longer than five minutes.

**NOTE:**

Brakes are automatically engaged when steering wheel is locked in NEUTRAL position.

**IMPORTANT:**

Before stopping engine, run at low idle for approximately five minutes to cool hot engine parts (and allow turbocharger to slow down while engine oil pressure is available).

4. Turn ignition key counterclockwise to OFF position.

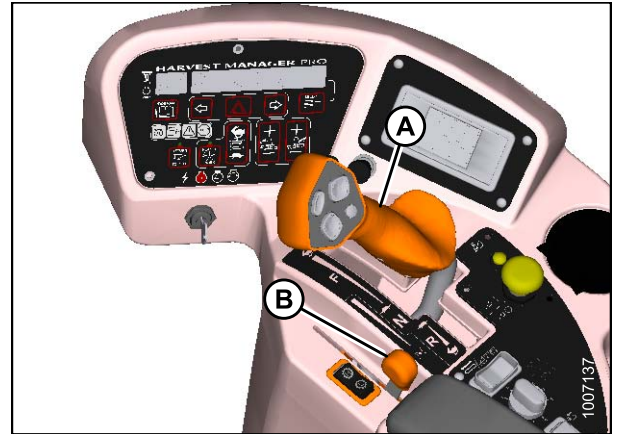

Figure 4.29: Operator Console

### 4.3.8 Adjusting Caster Tread Width

The rear casters can be adjusted to a narrow tread width to allow loading and shipping without having to remove them.

A narrow tread width also suits smaller headers by allowing more space to the uncut crop and provides more manoeuvrability around poles, irrigation inlets, or other obstacles.

A wider tread width is useful in heavy crops that produce large windrows so that runover is reduced.

**! DANGER**

To avoid bodily injury or death from unexpected startup of the machine, always stop the engine and remove the key from the ignition before leaving the operator's seat for any reason.

**! CAUTION**

Park on a flat, level surface with the header on the ground and the ground speed lever in N-DETENT position with the steering wheel locked.

## OPERATION

Adjust the caster tread width as follows:

1. Raise rear of windrower slightly so that most of the weight is off the casters, using a jack or other lifting device under the frame at (A).

**NOTE:**

Lifting device should have a lifting capacity of at least 5000 lb (2270 kg).

2. Remove six bolts (B) four on backside, two on underside, and washers from left and right side of walking beam.

3. Slide extensions inboard or outboard equal amounts and align holes at desired location.

**NOTE:**

Use the caster wheels to assist in moving the extensions by rotating the caster until the wheel is parallel to the walking beam.

**IMPORTANT:**

Caster wheels must be equidistant from center of windrower.

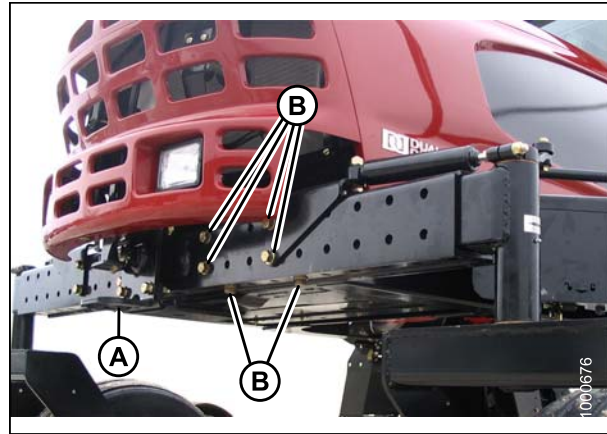

Figure 4.30: Caster Wheel Extensions



Figure 4.31: Caster Wheel Extensions

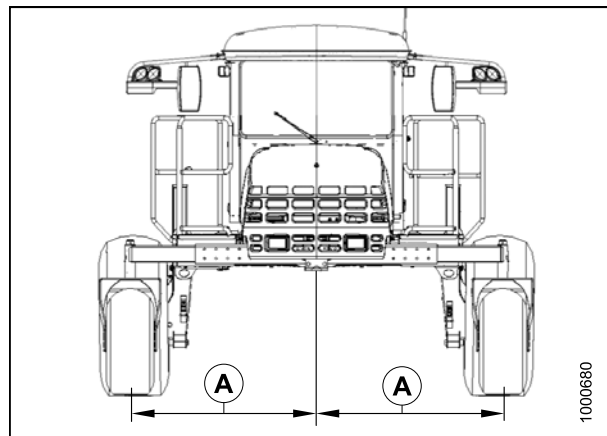

Figure 4.32: Adjustable Caster Wheels

## OPERATION

4. Position bracket (A) and install back bolts (C).
5. Tighten bolts as follows:
  - a. Snug bottom bolts (B), then snug back bolts (C).
  - b. Tighten and torque back bolts (C) to 330 ft lbf (447 N·m).
  - c. Tighten and torque bottom bolts (B) to 330 ft lbf (447 N·m).
6. Lower windrower to ground.

**IMPORTANT:**

Torque bolts after first 5 and 10 hours of operation.

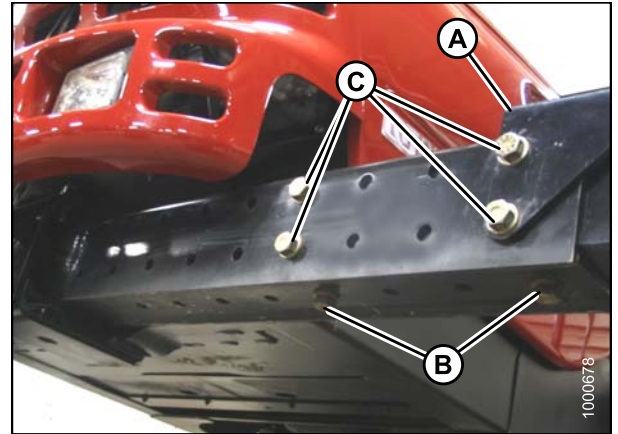

Figure 4.33: Caster Wheel Extensions

### 4.3.9 Transporting

#### *Driving on the Road*

The M155E4 Self-Propelled Windrower is designed to be driven on the road with the engine facing forward to provide better visibility for the Operator and improved stability for the machine. The windrower is also capable of being driven on the road in cab-forward mode, but at a reduced speed and under restricted conditions.

#### **⚠ WARNING**

Collision between windrower and other vehicles may result in injury or death.

#### **⚠ WARNING**

When driving windrower on public roadways:

- Obey all highway traffic regulations in your area. Use pilot vehicles in front and rear of windrower if required by law.
- Use slow-moving vehicle emblem and flashing warning lights unless prohibited by law.
- If width of attached header impedes other vehicle traffic, remove header and install a MacDon approved weight box.

#### **⚠ WARNING**

- Do NOT drive windrower on the road in the cab-forward mode, unless the optional lighting marking kit is installed, as lighting/reflector visibility will not be compliant with road regulations. Refer to [6.3.2 Lighting and Marking for Cab-Forward Road Travel, page 423](#).
- Do NOT drive windrower on a road or highway at night or in conditions that reduce visibility, such as fog or rain. The width of the windrower may not be apparent under these conditions.

#### **⚠ CAUTION**

Operate both steering wheel and ground speed lever slowly while becoming familiar with the machine. Remember that steering is more sensitive when speed-range control is in road speed position. Avoid the common tendency of new Operators to oversteer.

## OPERATION

### CAUTION

Check local laws for width regulations and lighting and marking requirements before transporting on roads.

Before driving windrower on a roadway:

1. Ensure HEADER DRIVE switch (A) is pushed to OFF position (down).
2. Clean flashing amber lamps, red tail and head lamps, and check that they work properly.
3. Clean all reflective surfaces and slow moving vehicle emblems.
4. Adjust interior rear view mirror and clean windows.



Figure 4.34: Header Drive Switch

5. Push LIGHT switch (A) to ROAD position to activate lamps. Always use these lamps on roads to provide warning to other vehicles.

#### NOTE:

The field lights will not turn on if the auto-road light feature is activated (i.e., windrower is in engine forward or cab-forward mode, out of park, high range switch position, and header off).

6. Use HIGH/LOW LIGHTS (B) as required when other vehicles are approaching.
7. Push BEACON switch (C) ON to activate beacons.

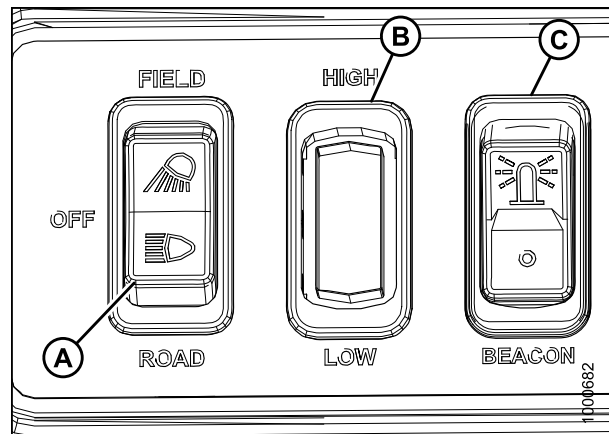

Figure 4.35: Light Switches

8. Press switch (A) on cab display module (CDM) to activate hazard lights.

#### IMPORTANT:

Switch ON the beacon and hazard lights when travelling on the road with the transmission in low range.



Figure 4.36: CDM



## OPERATION

- Set ground speed range switch (A) for ROAD speed. CDM will display ROAD GEAR at (F) if windrower is in engine-forward mode.

### NOTE:

Windrower can be moving, but speed must be less than 5 mph (8 km/h) for road gear to engage.

- Slowly push throttle (B) to full forward (operating speed). CDM should display 2320–2350 rpm (C).
- Slowly move the ground speed lever (GSL) (E) forward to desired speed which will be displayed at (F).
- If towing a header, refer to [Towing Header with Windrower](#), page 182.

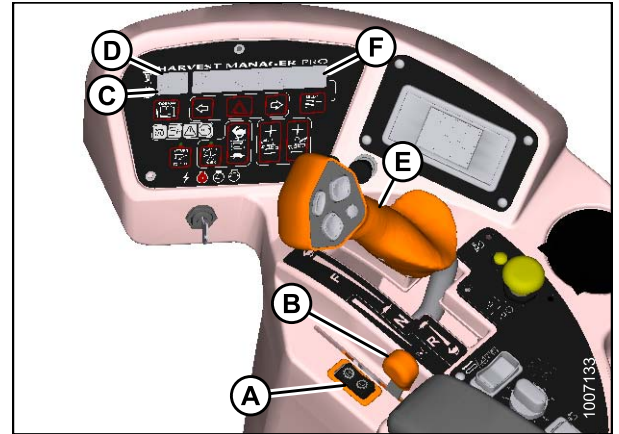

Figure 4.37: Operator Console

## WARNING

To avoid serious injury or death from loss of control:

- Do NOT make abrupt changes in steering direction.
- Anticipate turns and steep slopes by slowing down well in advance.
- Do NOT rapidly accelerate or decelerate while turning.

When travelling on steep slopes:

- Move ground speed lever (GSL) closer to NEUTRAL to reduce speed.
- Lower header.
- Move GROUND SPEED RANGE switch to L – low range.
- If the ground speed is greater than or equal to 25 mph (40 km/h), the CDM will display a warning message (SLOW DOWN) with an audible alert. Move GSL closer to NEUTRAL to reduce speed.

With header removed, steering control is reduced if weight is not added to drive wheels. If you must drive the windrower without header or MacDon weight system:

- Operate in low speed range.
- Do NOT exceed 1500 rpm engine speed.
- Avoid loose gravel and slopes.
- Do NOT tow a header.
- If control of machine is lost, immediately pull ground speed lever (GSL) to NEUTRAL.

## OPERATION

### Towing Header with Windrower

The windrower can be used to tow a MacDon draper header that has the slow speed transport option installed. Ensure the optional weight box or an approved header transporter is installed on the windrower to transfer weight to the lift arms.

#### WARNING

- A windrower without a header or weight box must **NOT** be used to tow headers due to reduced traction and possible loss of control.
- For towed equipment without brakes, do **NOT** exceed 20 mph (32 km/h).



Figure 4.38: Towing a Header

#### CAUTION

- To tow a header with an M155E4 Self-Propelled Windrower, the header must be equipped with the appropriate equipment to comply with local regulations.
- Before towing, conduct a pre-trip inspection to verify signal lighting and safety equipment is installed and functioning properly.
- Do **NOT** exceed the Combined Gross Vehicle Weight (CGVW) specified in table [4.1 Maximum Weight, page 182](#).
- To prevent damage and/or loss of control, ensure the machine and attached equipment are within the following weight limits:

Table 4.1 Maximum Weight

		lb	kg
<b>Maximum GVW</b> (includes mounted implements)		21,500	9750
<b>Maximum CGVW</b> (includes towed and mounted implements)		23,100	10,480
<b>Weight (A) on both drive wheels</b>	<b>Maximum</b>	18,750	8500
	<b>Minimum</b>	10,070	4570
<b>Maximum weight (B) on both caster tires</b>		6050	2750

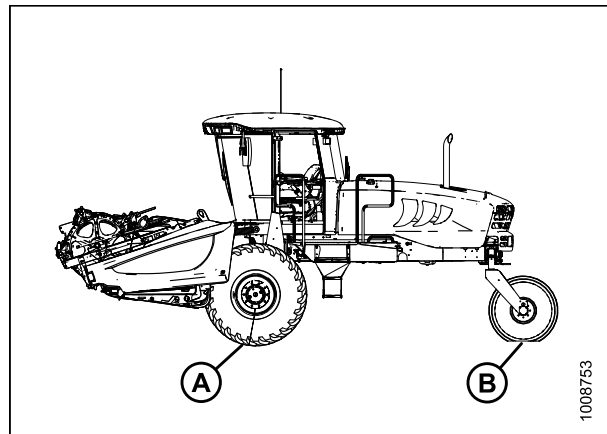

Figure 4.39: Maximum Weight

### Converting from Field to Transport Mode

#### DANGER

To avoid bodily injury or death from unexpected startup of the machine, always stop the engine and remove the key from the ignition before leaving the operator's seat for any reason.

## OPERATION

### DANGER

To avoid bodily injury from fall of raised header, always engage safety props when working on or around raised header, and before going under header for any reason.

1. Set header on the ground (field position).
2. Disconnect the following hydraulic and electrical connections:
  - a. **Left Side** – Store hydraulic hoses and electrical cable into the storage position. Refer to header operator's manual.
  - b. **Right Side** – Release the multi-link and place into storage on windrower. Refer to header operator's manual.
3. Retrieve temporary lift pin from storage location on weight box and install into rear hole (A) at the top of the lift arms. This provides additional lift height for transport wheel deployment.

### CAUTION

Check to be sure all bystanders have cleared the area.

4. Start engine and raise header to full height.
5. Stop engine and engage safety props on lift cylinders.
6. Deploy header slow speed transport system. Refer to header operator's manual.

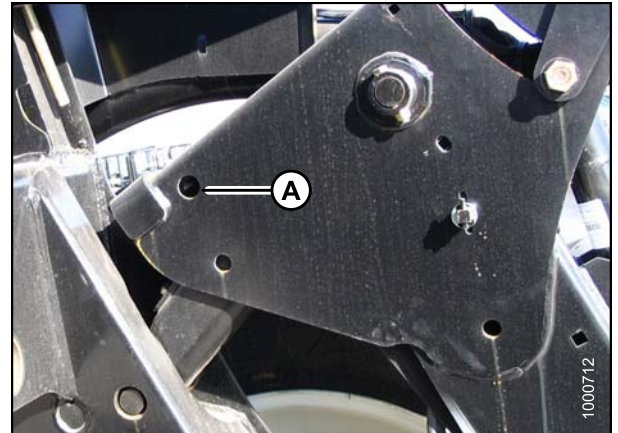

Figure 4.40: Lift Arms



Figure 4.41: Header in Transport Mode

## OPERATION

- Remove float pin from engaged position (A) and insert in storage location (B). Secure with lynch pin.

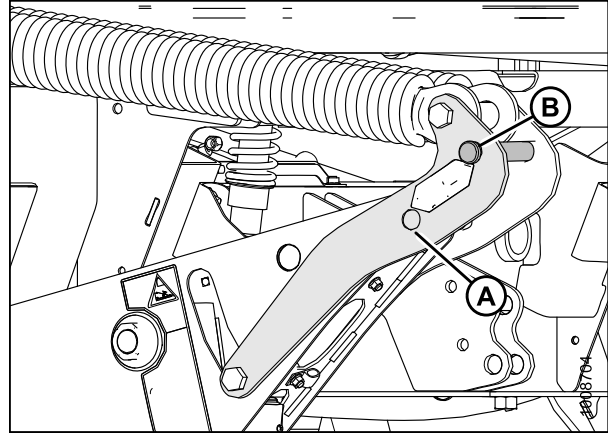

Figure 4.42: Lift Arms

- Remove pins (A) from lower end of lift linkages.

**NOTE:**

Pins (A) are also used to secure weight box to windrower linkage.

- Release the safety props on the header lift cylinders. Refer to [4.4.1 Header Safety Props, page 194](#).
- Start engine and lower header down onto the transport wheels.

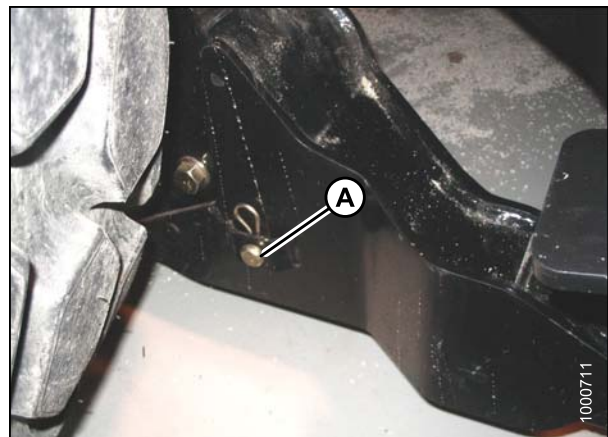

Figure 4.43: Lift Arms

- Use the HEADER TILT switches to release load on the center-link if necessary.
- Shut down engine and remove key from ignition.

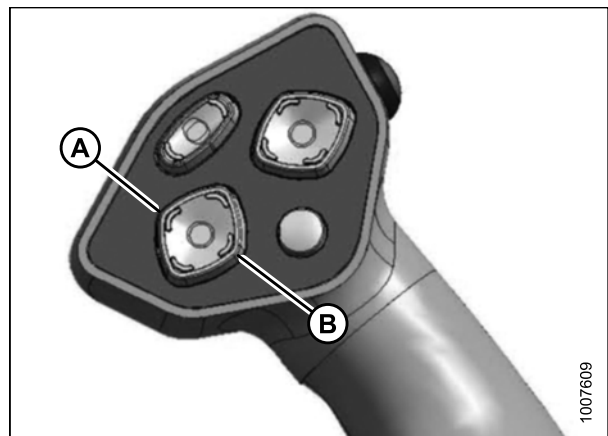

Figure 4.44: Ground Speed Lever (GSL)

A - Header Tilt Down

B - Header Tilt Up

## OPERATION

Disconnect the center-link as follows:

13. To unlock the center-link, pull up on latch (A) and position latch into notch (B) on top of hook.
14. Lift center-link off header pin.

**NOTE:**

If center-link self-alignment kit is installed, start engine and raise center-link with the REEL UP switch on the ground speed lever (GSL).

15. Slowly back windrower away from header, shut engine OFF, and remove key from ignition.

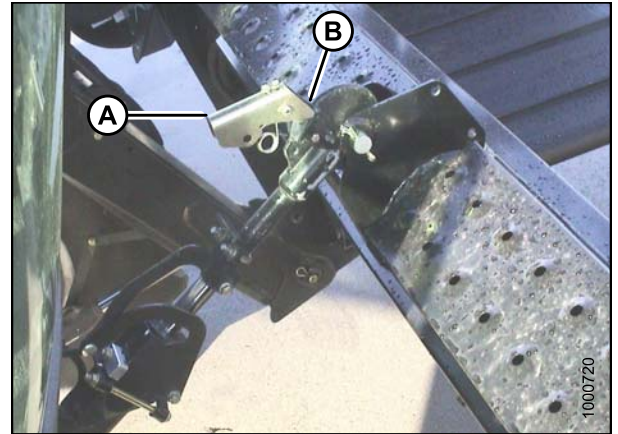

Figure 4.45: Hydraulic Link

### Attaching Header Transport Hitch to Header

Attach header transport hitch to header as follows:

1. Position end (A) of the aft section onto front wheel hook (B).
2. Push down until latch (C) captures the end (A).
3. Secure latch (C) with clevis pin (D).

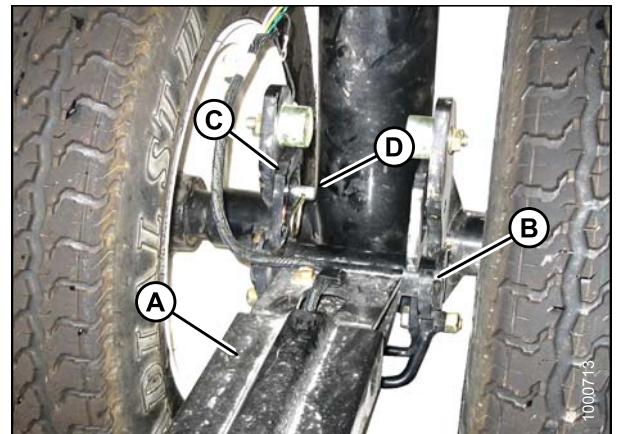

Figure 4.46: Transport Hitch

4. Remove the L-pin from end (A) of aft section (if installed).

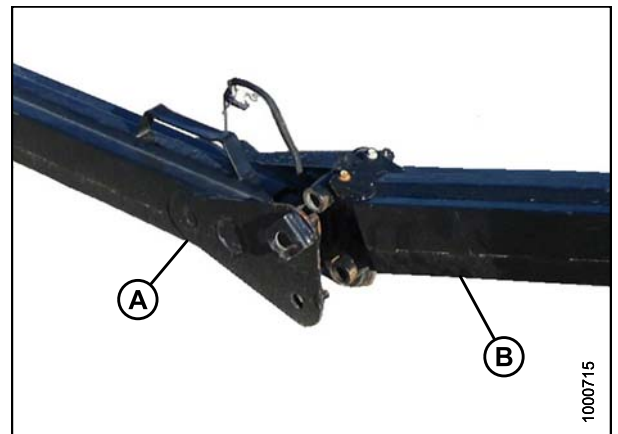
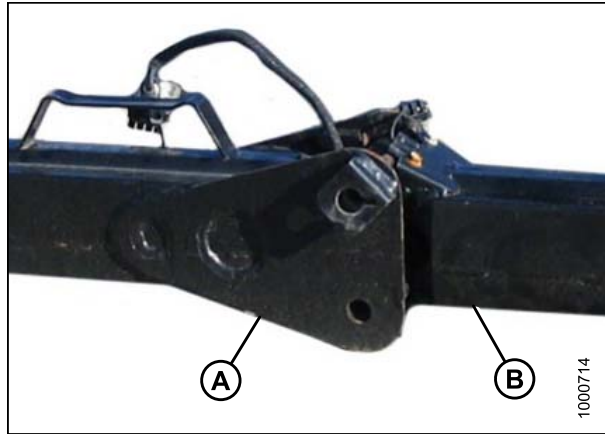

Figure 4.47: Transport Hitch

## OPERATION

5. Position end (B) of the forward section into end (A) of the aft section and lower forward section into aft section.



**Figure 4.48: Transport Hitch**

6. Fully insert L-pin (A) in upper hole and turn pin to lock it. Secure with ring pin (B).
7. Make electrical connection at the joint (C).

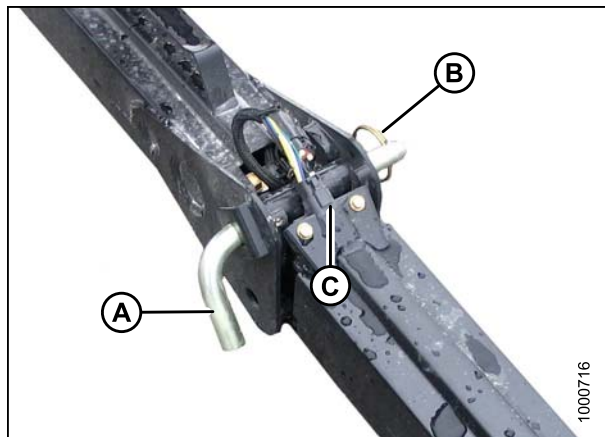

**Figure 4.49: Transport Hitch**

8. Make the electrical connection at the header wheel (A).



**Figure 4.50: Header Transport Wheel**

## OPERATION

### IMPORTANT:

To prevent damage to the lift system when lowering header lift linkages without a header or weight box attached to windrower, ensure that float engagement pin is installed in storage location (B) and **NOT** installed at hole location (A).

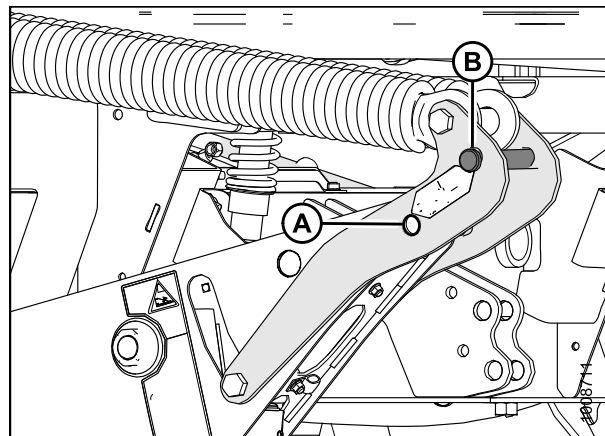

Figure 4.51: Lift Linkage

9. Drive windrower so that windrower lift arms are positioned into the weight box pockets.
10. Raise lift arms slightly, install locking pins (A) into pockets, and through windrower header lift linkages. Secure with hairpin.

### NOTE:

Pins (A) were previously removed from the header lift linkage lower end.

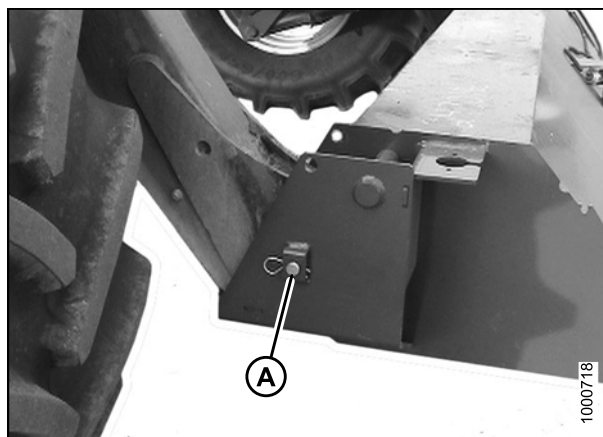

Figure 4.52: Windrower Lift Linkage

11. Route the weight box harness (A) to the electrical connector at the left side lift linkage and connect harness to connector on windrower (B).
12. Raise lift arms fully, shut engine OFF, and remove key from ignition.

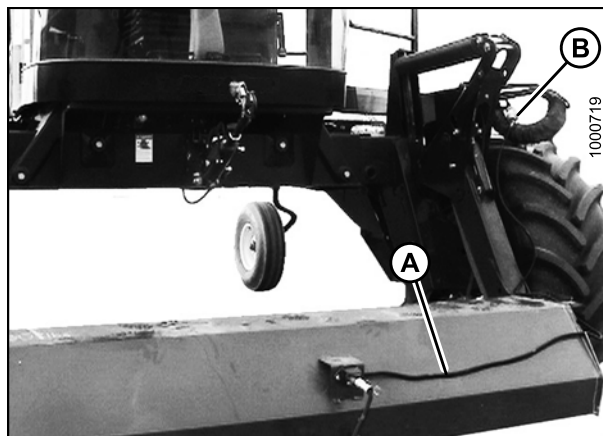
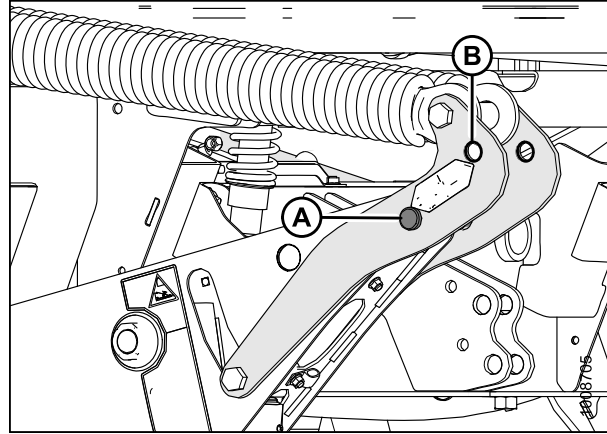

Figure 4.53: Weight Box

## OPERATION

13. Move float pins from storage location (A) to engaged position (B).



**Figure 4.54: Lift Linkage**

14. Start engine and press HEADER DOWN switch (A) on ground speed lever (GSL) to lower lift arms until the lift arm lifts away from the linkage at the rear of the lift arm.

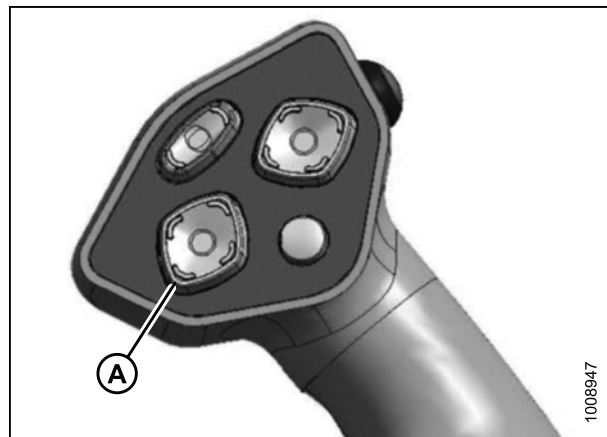

**Figure 4.55: GSL**

15. Attach slow speed transport hitch to the weight box tongue with drawbar pin. Secure using lynch pin (A). Attach safety chain (B).
16. Connect hitch harness (C) to electrical socket at front of weight box.

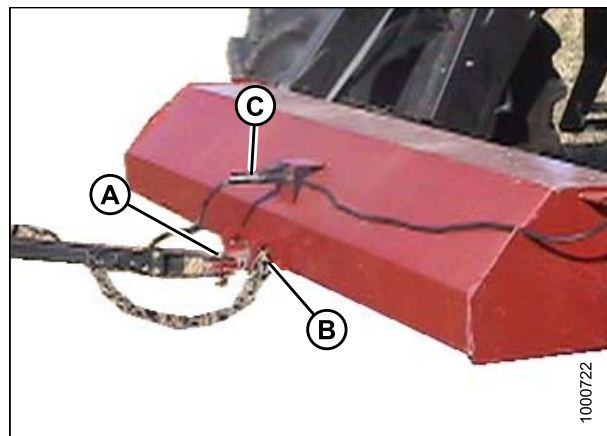

**Figure 4.56: Weight Box**



## OPERATION

17. Remove the temporary lift pins (A) (should be loose in lift arm) and place into storage holes on weight box.

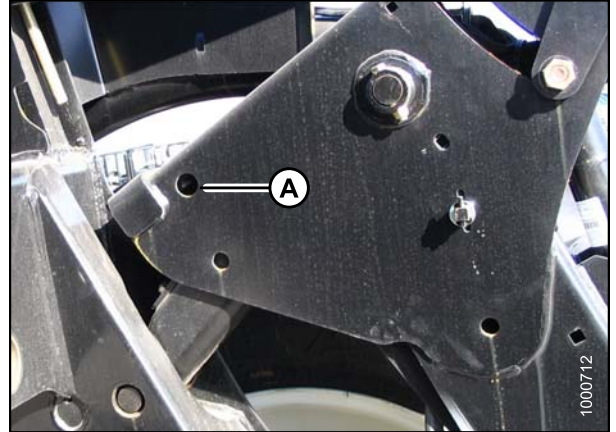

Figure 4.57: Lift Arms

### Converting from Transport Mode to Field Operation

#### DANGER

To avoid bodily injury or death from unexpected startup of the machine, always stop the engine and remove the key from the ignition before leaving the operator's seat for any reason.

1. Stop engine and remove key from ignition.
2. Disconnect electrical harness at connector (B) from windrower and store harness (A) on weight box.

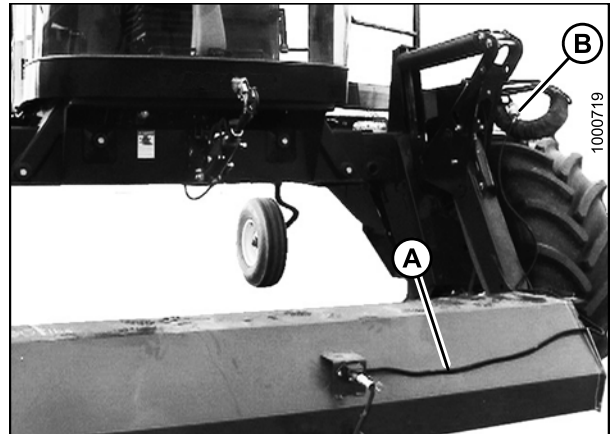

Figure 4.58: Electrical Harness

3. Disconnect wiring connector (A) at front wheel.



Figure 4.59: Header Transport Wheel

## OPERATION

4. Remove clevis pin (D).
5. Push latch (C) and lift tow-bar (A) from hook. Release latch and replace clevis pin.
6. Unhook tow-bar from weight box.

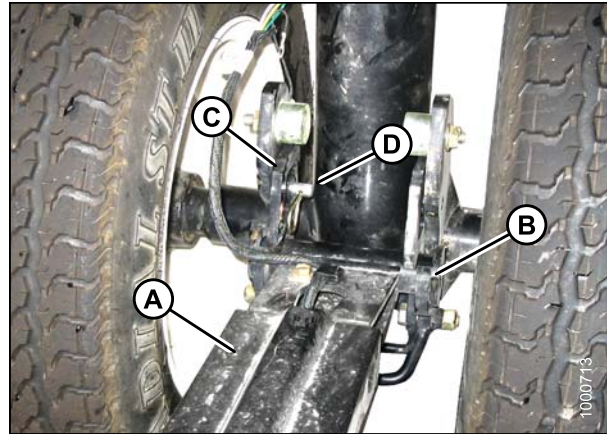

Figure 4.60: Header Transport Wheel

### CAUTION

Check to be sure all bystanders have cleared the area.

7. Start engine and lower lift arms until rear of lift arms floats up and away from the lift arm mechanism.
8. Stop engine and remove key from ignition.
9. Remove temporary lift pins (A) from weight box and install pins (F) into holes at rear of lift arms.
10. Start engine and fully raise lift arms. Stop engine and remove key from ignition.
11. Engage lift cylinder safety props. Refer to [4.4.1 Header Safety Props](#), page 194.
12. Move float pins from working hole location (A) to disengage the float and store pins at storage hole location (B).

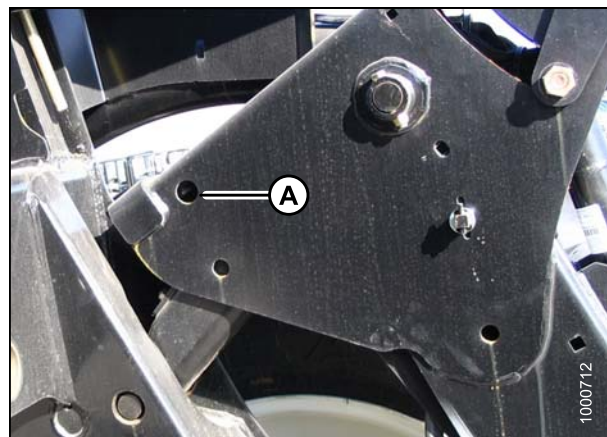

Figure 4.61: Lift Arms

### IMPORTANT:

To prevent damage to the lift system when lowering header lift linkages without a header or weight box attached to windrower, ensure that float engagement pin is installed in storage hole location and **NOT** installed in working hole location.

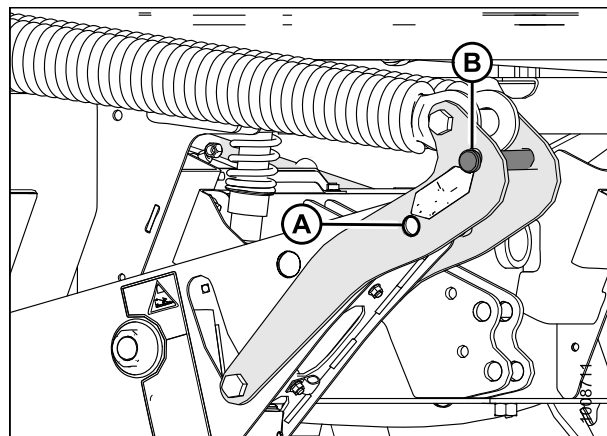

Figure 4.62: Float Pins

## OPERATION

13. Remove pins (A) securing lift linkages to weight box, and retain pins for attaching header to windrower. Disengage lift cylinder safety props. Refer to [4.4.1 Header Safety Props, page 194](#).

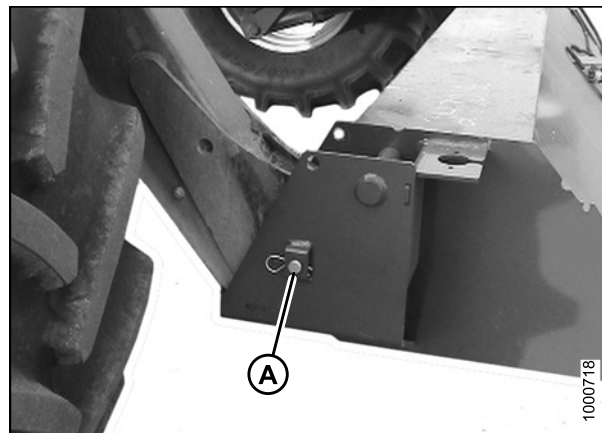

Figure 4.63: Weight Box

14. Start engine, lower weight box onto blocks, and back away.
15. Attach header to windrower. Refer to [4.5 Attaching and Detaching Headers, page 214](#).
16. Convert header into field position. Refer to header operator's manual for procedure.
17. Before operating the machine, double-check that all pins are secure and that all safety equipment is installed and fully functional.
18. Proceed with operation of header.

### *Towing the Windrower (Emergency)*

In emergency situations, for example, towing out of a field or into a shop, windrower may be towed without a trailer, providing the following precautions are followed:

### **WARNING**

**A proper towing apparatus is critical to safe towing. Use the following guidelines:**

- Do NOT attach directly from hitch to walking beam. Slope of tow-bar will not provide proper transfer of braking force to windrower, causing loss of control.
- For proper steering, towing apparatus should be attached to BOTH left and right cab-forward frame members, and should attach to tow-bar at same height as towing vehicle hitch.
- Towing apparatus should be removed for field operation, to avoid interference with windrow.

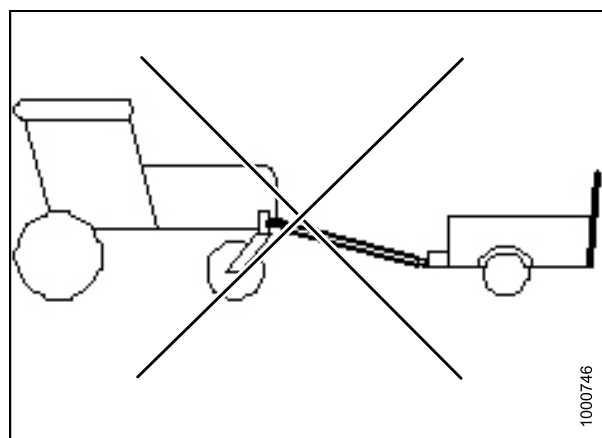

Figure 4.64: Improper Towing Procedure

## OPERATION

### **WARNING**

With final drives disengaged, the windrower may roll on a sloped surface. Before disengaging final drives, attach windrower to towing vehicle. After towing, engage drives and ensure ground speed lever (GSL) is in N-DETENT before detaching from towing vehicle.

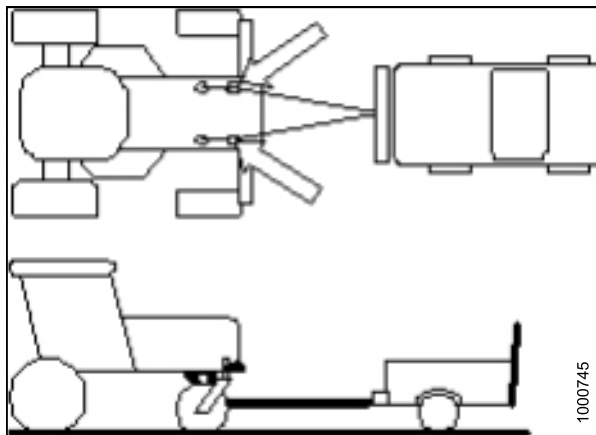

Figure 4.65: Correct Towing Procedure

### **IMPORTANT:**

- Failure to disengage final drives before towing will result in serious transmission damage.
- Do **NOT** exceed 16 mph (26 km/h) when towing windrower.
- Do **NOT** use this towing method for normal transporting of windrower.
- Even with final drives disengaged, rolling speeds of more than 16 mph (26 km/h) will cause final drive gears to run at excessive speeds, possibly severely damaging or causing the unit to fail.

### *Final Drives*

Disengage and engage final drives as follows:

1. Remove the two bolts (A) at the center of drive wheel.
2. Remove cap (B) and flip over so that dished side faces in. The cap depresses a pin that disengages the gearbox.
3. After towing, reverse cover (B) to engage final drives. Be sure plunger at center of wheel pops out to engage drive.

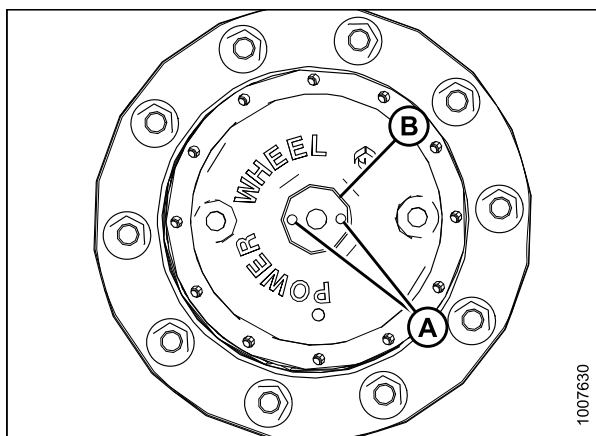

Figure 4.66: Final Drives

### **4.3.10 Storing the Windrower**

At the end of each operating season, you need to store your windrower properly.

### **WARNING**

Never use gasoline, naphtha, or any volatile material for cleaning purposes. These materials are toxic and can be flammable.

### CAUTION

Never operate engine in a closed building. Proper ventilation is required to avoid exhaust gas hazards.

### CAUTION

Remember when working around storage batteries that all of the exposed metal parts are live. Never lay a metal object across the terminals because a spark and short circuit will result.

1. Clean the windrower thoroughly.
2. Store windrower in a dry protected place.
3. Remove battery. Refer to [Removing Batteries, page 359](#).
4. Bring to full charge and store in a cool, dry place not subject to freezing.
5. If stored outside, always cover windrower with a waterproof tarpaulin or other protective material. This will protect the switches, instruments, tires, etc. from inclement weather.
6. If no cover is available; seal air cleaner intake and exhaust pipe with plastic bags and/or waterproof tape.
7. If possible, block up windrower to take weight off tires. If it is not possible to block up the machine, increase tire pressure by 25% for storage. Adjust to recommended operating pressure before next use.
8. Repaint all worn or chipped painted surfaces to prevent rust.
9. Lubricate the windrower thoroughly, leaving excess grease on fittings to keep moisture out of bearings. Apply grease to exposed threads and sliding surfaces of components.
10. Check for worn components and repair. Tighten loose hardware and replace any missing hardware. Refer to [8.2 Recommended Torques, page 446](#).
11. Check for broken components and order replacements from your Dealer. Attention to these items right away will save time and effort at beginning of next season.
12. Add approved rust inhibitor to the engine oil in accordance with the manufacturer's instructions. Run engine to operating temperature to mix inhibitor with oil, unless otherwise specified.
13. To prevent condensation, fill hydraulic oil reservoir to filler neck with approved hydraulic system oil. Refer to [5.10.1 Checking and Filling Hydraulic Oil, page 389](#).
14. Test engine coolant antifreeze concentration to ensure it is sufficient to protect engine against lowest expected temperature.

## 4.4 Operating with a Header

The M155E4 Self-Propelled Windrower is designed to operate with a MacDon A-Series Auger Header, R-Series Rotary Header, or D-Series Rigid Draper Header with or without a Hay Conditioner.

This section describes the attachment and detachment procedures and operating instructions for these header types.

### 4.4.1 Header Safety Props

Safety props are located on both header lift cylinders on the windrower.

#### DANGER

**To avoid bodily injury from fall of raised header, always engage safety props when working on or around raised header, and before going under header for any reason.**

Engage safety props as follows:

1. Start engine and press header up (A) switch to raise header to maximum height.
2. Rephase cylinders if one end of the header does not raise fully. If rephasing is required, proceed as follows:
  - a. Press and hold the header up (A) switch until both cylinders stop moving.
  - b. Continue to hold the switch for 3–4 seconds. Cylinders are now phased.



**Figure 4.67: Ground Speed Lever (GSL)**

## OPERATION

3. Pull lever (A) and rotate toward header to lower safety prop (B) onto cylinder. Repeat for opposite cylinder.

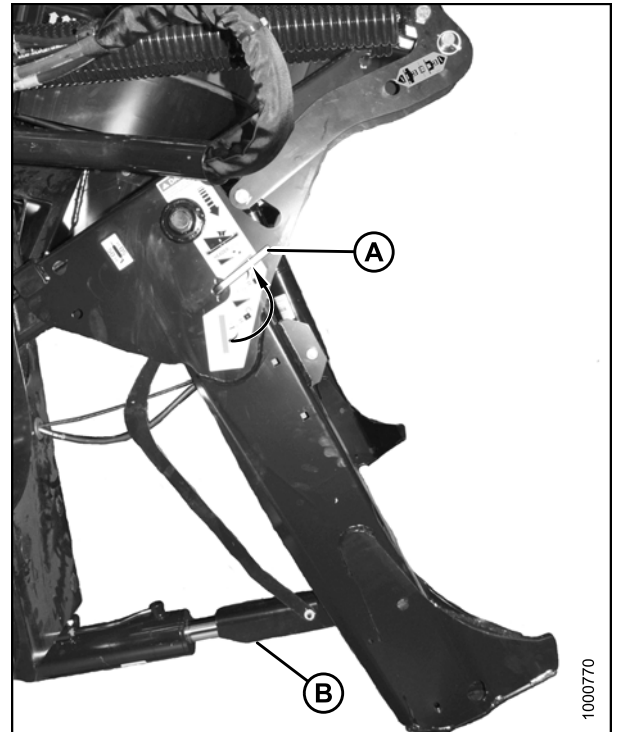

**Figure 4.68: Safety Prop**

4. Disengage safety props by turning lever (A) away from header to raise safety prop until lever locks into vertical position. Repeat for opposite cylinder.
5. Start engine, choose a level area, and lower header to the ground.
6. Stop the engine and remove the key.

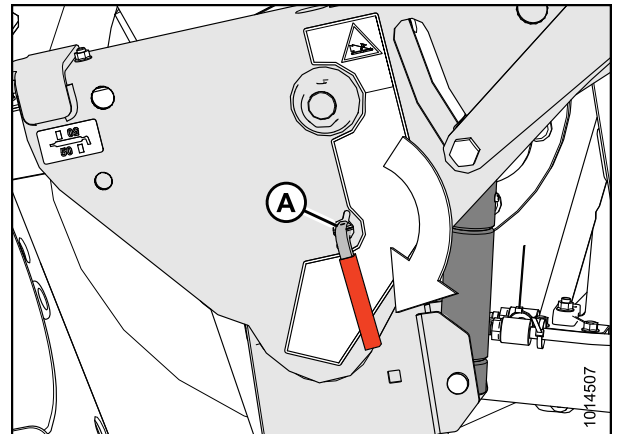

**Figure 4.69: Safety Prop**

### 4.4.2 Header Float

The header float feature allows the header to closely follow ground contours and respond quickly to sudden changes or obstacles. The float setting is ideal when the cutterbar is on the ground with minimal bouncing, scooping, or pushing soil.

#### **IMPORTANT:**

- Set header float as light as possible—without excessive bouncing—to avoid frequent breakage of knife components, scooping soil, or soil build-up at the cutterbar in wet conditions.
- Avoid excessive bouncing (resulting in a ragged cut) by operating at a slower ground speed when the float setting is light.
- Install header options (upper cross auger, skid shoes, transport kit, etc.) before setting header float. If the SST transport tow bar will be stored on header during operation set float with tow bar in place.
- Adjust the float when adding or removing optional attachments that affect the weight of the header.
- Refer to your header operator's manual for setting float and adjustment guidelines.

#### *Float Operating Guidelines*

When working with the cutterbar on the ground:

- Set center-link to mid-range position (05.0 on cab display module [CDM]). Refer to [4.4.5 Adjusting Header Angle, page 204](#).
- Minimize scooping rocks by adjusting the header skid shoes downward to raise guards when operating at the flattest header angle.
- Adjust header height or adjust header angle to minimize pushing soil.

When working with the cutterbar off the ground (draper header only):

- Set center-link to mid-range position (05.0 on CDM). Refer to [4.4.5 Adjusting Header Angle, page 204](#).
- Balance the amount of header weight carried by the float and stabilizer wheels. Refer to your draper header operator's manual.
- Use the CDM controls to automatically maintain cutting height. Refer to [4.4.6 Cutting Height, page 207](#).

#### *Checking Float*

The M155E4 is equipped with primary (coarse) and secondary (fine) float adjustment systems. The primary or coarse adjustment uses drawbolts to change the tension on the springs in the lift linkages. The secondary or fine adjustment uses hydraulic cylinders to change the spring tension.



## OPERATION

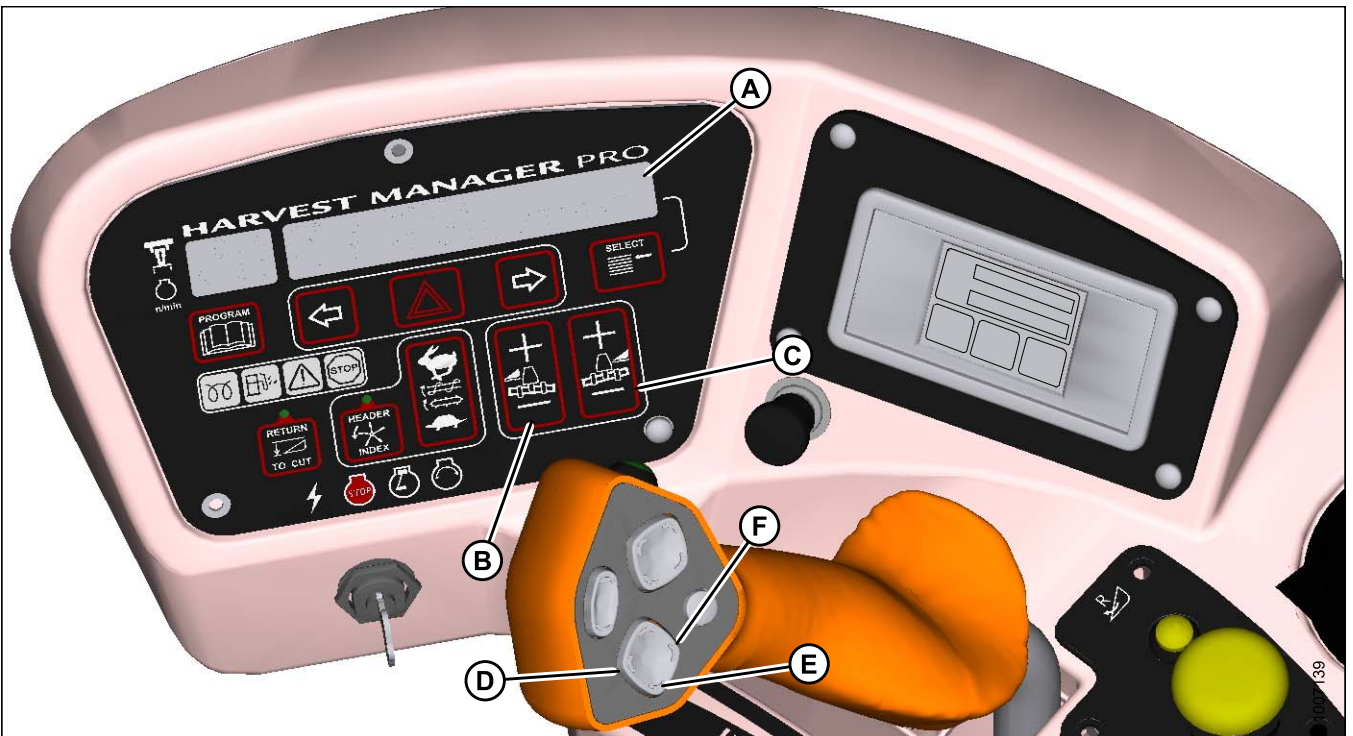

**Figure 4.70: Cab Display Module (CDM) Float Adjustment**

A - CDM Display  
D - Header Tilt Down

B - Left Float Adjustment  
E - Header Lower

C - Right Float Adjustment  
F - Header Tilt Up

Check header float as follows:

### CAUTION

**Check to be sure all bystanders have cleared the area.**

1. Start the engine.
2. Using HEADER TILT switches (D, F), set center-link to mid-range position (5.0 on CDM [A]).

#### **NOTE:**

If equipped with the optional draper header reel drive (B5496), adjust reel fore-aft to your normal operating position.

3. Using HEADER DOWN switch (E), lower header fully with lift cylinders fully retracted.
4. Set left (B) and right (C) float fine adjustments on CDM to approximately 5.0 as follows:
  - a. Using FLOAT SELECTOR switch (B), push + to increase float or – to decrease float on left side of header. CDM display (A) will indicate selected float for left side, for example (5.0 L FLOAT R XX.X).
  - b. Repeat for right side float with switch (C). Display will indicate float for both sides, for example (5.0 L FLOAT R 5.0).
5. Shut down engine and remove key.
6. Grasp the end of the header and lift. The force to lift should be as noted in the following table and should be approximately the same at both ends.

## OPERATION

Header	Force Required to Lift Header at the Ends with Lift Cylinder Fully Retracted
Auger	75–85 lbf (335–380 N)
Rotary	95–105 lbf (426–471 N)
Draper	75–85 lbf (335–380 N) with stabilizer/transport wheels raised (if equipped)

### Adjusting Float Using Drawbolts

Coarse float adjustment is done using the drawbolts located on either side of the windrower.

If necessary, coarse adjust the float with the drawbolts as follows:

### CAUTION

Check to be sure all bystanders have cleared the area.

1. Start engine.
2. Using HEADER UP (A) switch on ground speed lever (GSL), raise the header fully, shut down engine, and remove key.
3. Turn drawbolt (A) clockwise to increase float (makes header lighter) or counterclockwise to decrease float (makes header heavier).
4. Recheck the header float.



Figure 4.71: GSL

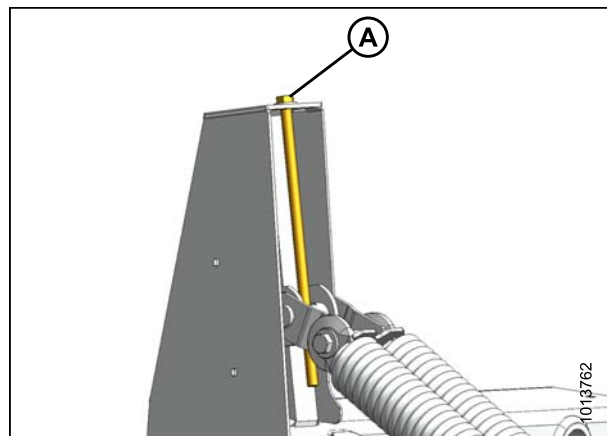

Figure 4.72: Header Float Adjustment

## OPERATION

### Float Options

For draper headers without the deck shift option, auger headers, and rotary headers, the float can be preprogrammed for three types of windrowing conditions.

Example:

- Position 1: Border
- Position 2: Normal
- Position 3: Rocky

Set float presets as follows:

1. Engage header.
2. Push FLOAT PRESET SWITCH (A) to Position 1 (B).

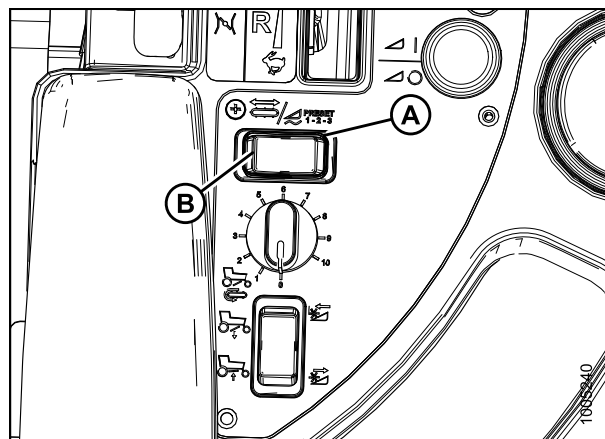

Figure 4.73: Float Preset Switch

3. Using HEADER TILT switches (D, F), set center-link to mid-range position (5.0 on CDM [A]).

**NOTE:**

If equipped with the optional draper header reel drive (B5496), adjust reel fore-aft to your normal operating position.

4. Using HEADER DOWN switch (E), lower header fully with lift cylinders fully retracted.
5. Set left (B) and right (C) float fine adjustments on CDM to approximately 5.0 as follows:
  - a. Using FLOAT SELECTOR switch (B), push + to increase float or – to decrease float on left side of header. CDM display (A) will indicate selected float for left side, for example (5.0 L FLOAT R XX.X).
  - b. Repeat for right side float with switch (C). Display will indicate float for both sides, for example (5.0 L FLOAT R 5.0).

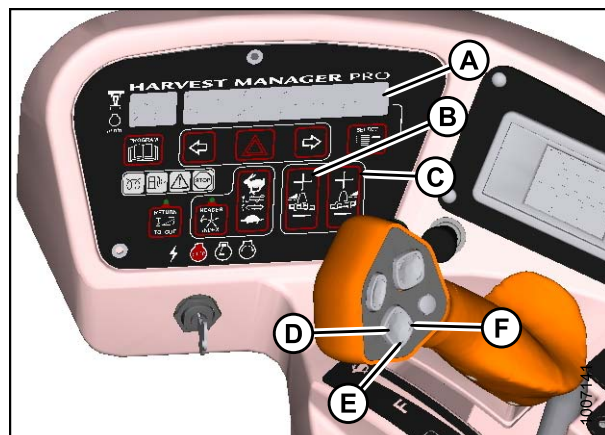

Figure 4.74: Operator Console

## OPERATION

6. Select a second preset with the FLOAT PRESET 2 SWITCH (C).
7. Repeat Steps [1., page 199](#) and [2., page 199](#) to set the float.
8. Select a third preset with the FLOAT PRESET 3 SWITCH (D).
9. Repeat steps [1., page 199](#) and [2., page 199](#) to set the float.
10. Operate windrower.

### NOTE:

For draper headers with the deck shift option, the float can be preprogrammed to compensate for weight distribution when the decks are shifted. Refer to [Setting Float Options with Deck Shift, page 269](#).

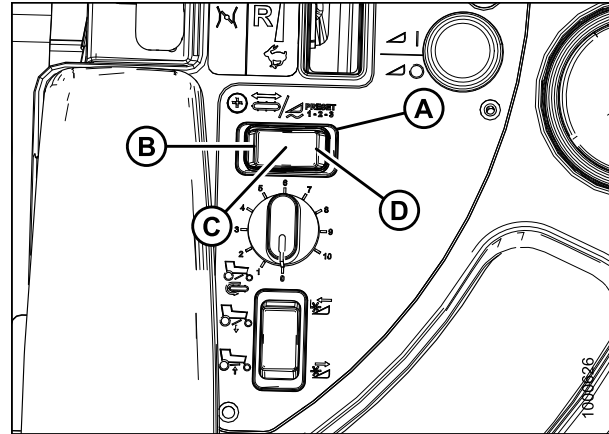

Figure 4.75: Float Preset Switch

### 4.4.3 Levelling the Header

The windrower linkages are factory-set to provide the proper level for the header and should not normally require adjustment.

### DANGER

To avoid bodily injury or death from unexpected startup of the machine, always stop the engine and remove the key from the ignition before leaving the operator's seat for any reason.

If the header is not level, check the windrower tire pressures before adjusting the levelling linkages.

### NOTE:

The float springs are **NOT** used to level the header.

To level the header, follow these steps:

1. Place float pins in locked out location (A).

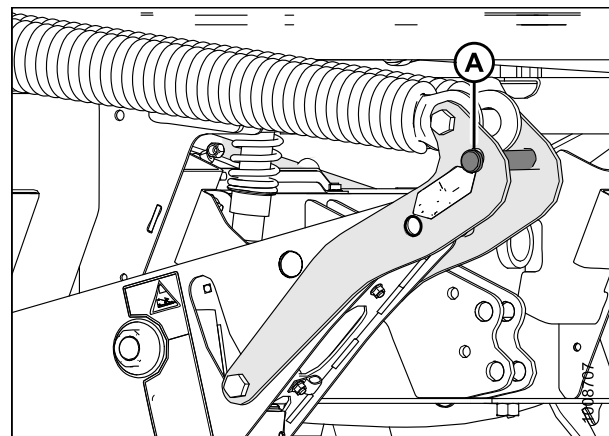
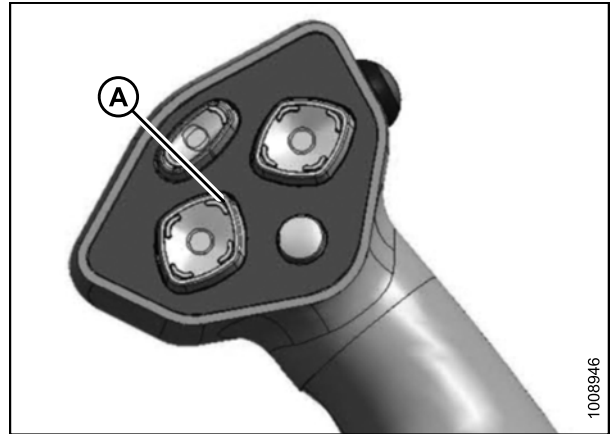

Figure 4.76: Float Pins – Disengaged

## OPERATION

2. Park windrower on level ground.
3. Raise header fully and hold momentarily to allow lift cylinders to rephase.



**Figure 4.77: Ground Speed Lever (GSL)**

4. Set header approximately 6 in. (150 mm) off ground and check that member (A) is against link (B). Stop engine and remove key from ignition.
5. Measure distance to ground at both ends of header and determine the end that is higher.
6. If adjustment is necessary, start engine and raise header fully. Turn off engine and remove key from ignition.

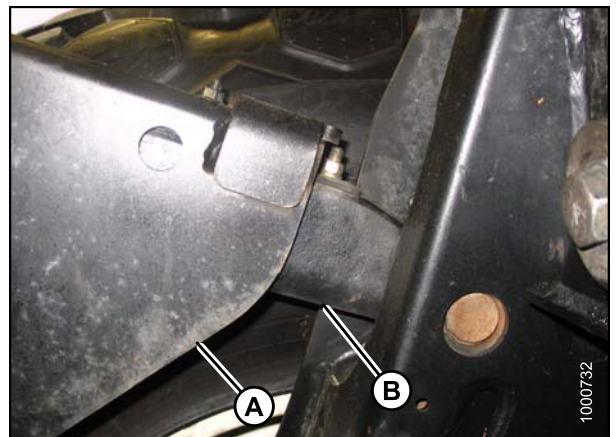

**Figure 4.78: Lift Linkage**

7. Move float pins to engaged position (A).

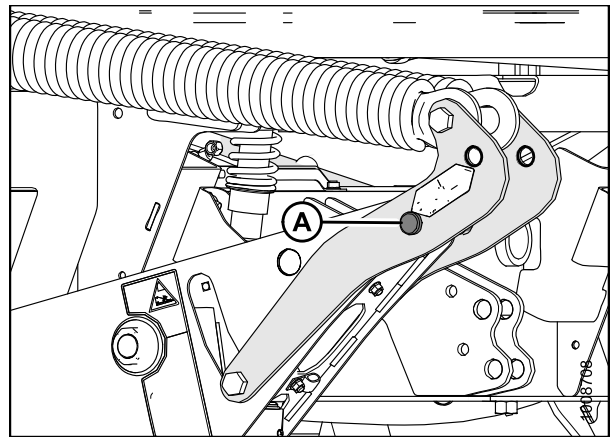

**Figure 4.79: Float Pins – Engaged**

## OPERATION

8. Start engine and lower header onto ground until member (A) lifts off link (B) on both sides.
9. Stop engine and remove key.

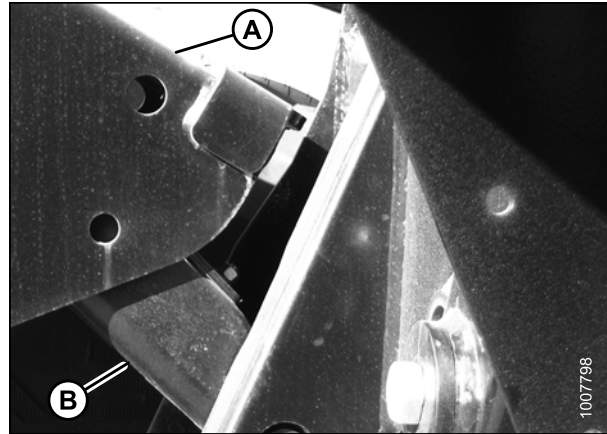

Figure 4.80: Lift Linkage

10. On high side, remove nut, washer, and bolt (A) that attaches shims (B) to link.
11. Remove one or both shims (B), and reinstall the hardware (A).
12. Start engine and raise header fully.
13. Stop engine and remove key from ignition.
14. Move float pins to disengaged position.
15. Start engine and set header approximately 6 in. (150 mm) off ground and check that member (A) is against link (B). Stop engine and remove key from ignition.
16. Measure distance to ground at both ends of header.
17. If additional levelling is required, repeat Steps 6., page 201 to 9., page 202 and install the removed shim on the opposite linkage.

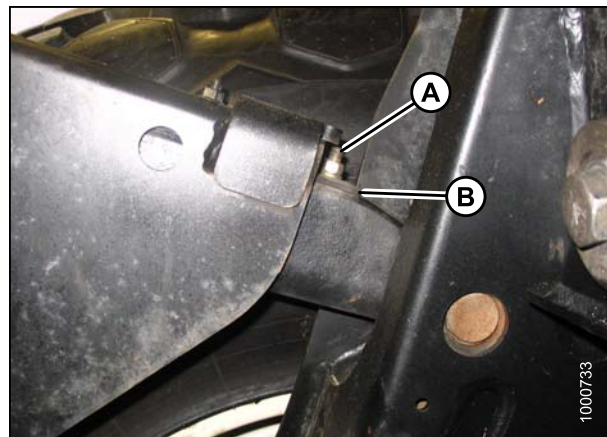

Figure 4.81: Lift Linkage

### NOTE:

If required, additional shims are available from your Dealer.

18. Once header is level, return float pins to their engaged position (A).

### NOTE:

Float does **NOT** require adjustment after levelling header.

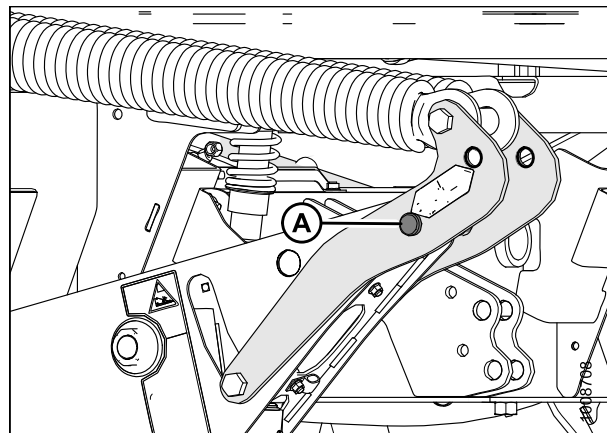

Figure 4.82: Float Pins – Engaged

## OPERATION

### 4.4.4 Header Drive

All header controls are conveniently located on the operator's console and on the ground speed lever (GSL) handle.

#### NOTE:

Some controls are optional equipment and may not be present in your unit. Some controls may be installed, but will be nonfunctional for certain headers.

#### *Engaging and Disengaging the Header*

#### IMPORTANT:

Always move throttle lever back to idle before engaging header drive. Do **NOT** engage header with engine at full rpm.

#### CAUTION

Check to be sure all bystanders have cleared the area.

#### 1. To Engage Header:

- a. Move throttle (A) to adjust engine speed to idle.
- b. Push the center down and pull up the HEADER DRIVE switch (B) to engage header drive. A slight delay between switch ON and operating speed is normal.

#### 2. To Disengage Header:

- a. Push HEADER DRIVE switch (B) down to disengage header drive.



Figure 4.83: Operator Console

## OPERATION

### *Reversing the Header*

**Reverse** the header as follows:

1. Push down and hold HEADER DRIVE REVERSE button (A) and pull up the HEADER DRIVE switch (B).
2. CDM will display HEADER REVERSE.
3. Release REVERSE button (A) to stop header.
4. Push down the HEADER DRIVE switch (B) to OFF, so that it can be restarted.

**NOTE:**

To engage header drive, push down, and pull up HEADER DRIVE knob.



**Figure 4.84: Operator Console**

### **4.4.5 Adjusting Header Angle**

Header angle is defined as the angle between the ground and the drapers/cutterbar. It is adjustable to accommodate crop conditions and/or soil type.

Refer to the appropriate header operator's manual for the range of adjustment and recommended settings for your particular header.

The header angle can be hydraulically adjusted from the cab without shutting down the windrower when the windrower is equipped with the hydraulic center-link. A readout on the cab display module (CDM) allows you to establish settings for each crop condition.

**IMPORTANT:**

- Changing header angle will affect float slightly because it has the effect of making the header lighter or heavier.
- To prevent excessive guard breakage when conditions are not suited to heavier float (e.g., rocky or wet), do **NOT** use the TILT CONTROL. Instead, use the HEADER HEIGHT switch.



## OPERATION

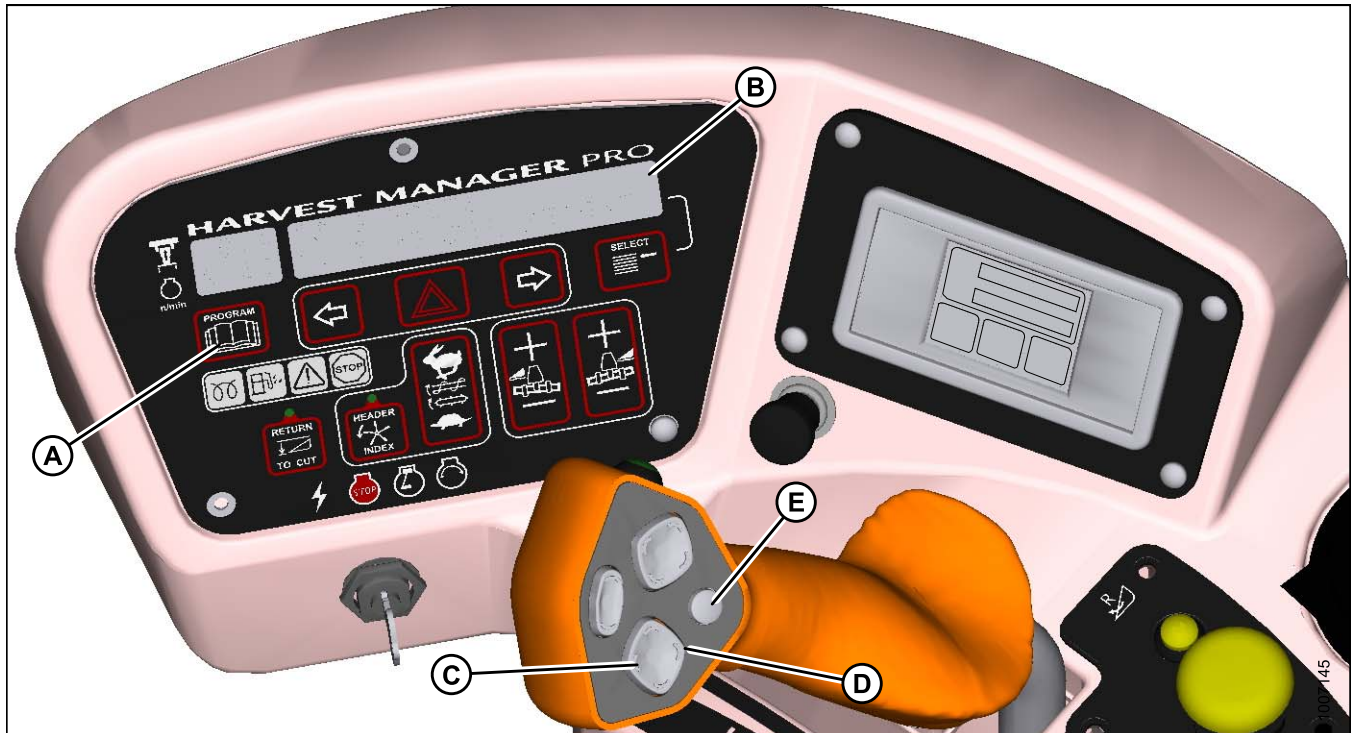

**Figure 4.85: Operator Console**

A - Program Button  
D - Header Tilt Up

B - Display  
E - Display Selector

C - Header Tilt Down

Adjust the header angle as follows:

- To decrease (flatten) header angle, operate HEADER TILT UP switch (D) on ground speed lever (GSL) handle so that cylinder retracts. The CDM display will show a reading on the lower line of decreasing value between 00.0 and 10.0.
- To increase (steepen) header angle, operate HEADER TILT DOWN switch (C) on GSL handle so the cylinder extends. The CDM display will show a reading on the lower line of increasing value between 00.0 and 10.0.

### **NOTE:**

The HEADER TILT switch can be locked out to prevent inadvertent header angle changes when pressing the HEADER HEIGHT control switches. Refer to [Activating the Header Tilt Control Lock Out, page 128](#).

### *Checking Self-Locking Center-Link Hook*

Periodically check the operation of the hook locking mechanism and ensure that it is working properly as follows:

## OPERATION

1. If header is attached to windrower, disconnect center-link hook from header by pulling up on handle (A) to release the locking device and then lifting the hook off the header pin.

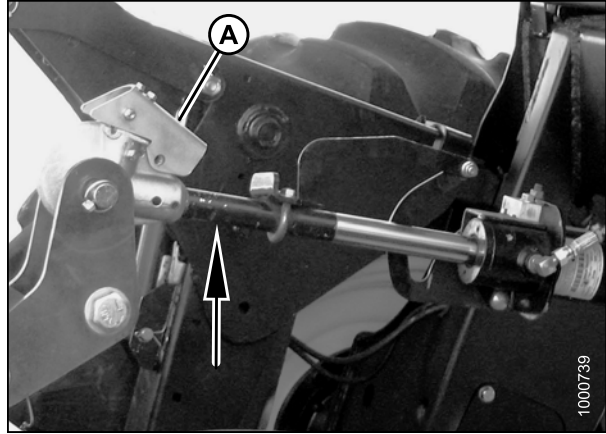

Figure 4.86: Center-Link

2. Lower the handle (A) into the **LOCK** position.
3. Push up on lock pin (B) only. Handle should catch on casting and pin should **NOT** lift.

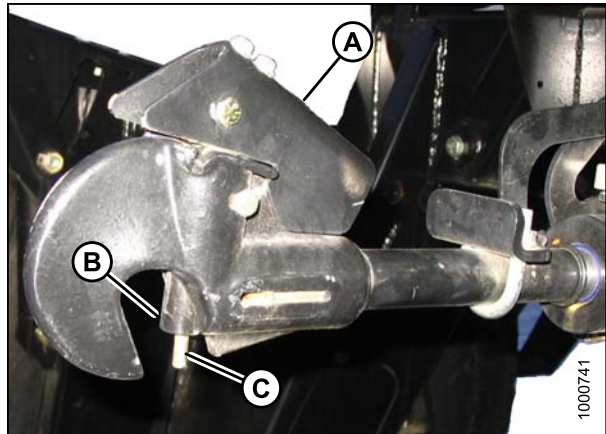

Figure 4.87: Center-Link Hook

A - Handle

B - Lock Pin

C - Actuator Rod

4. Push up on actuator rod and lock pin should lift with the handle.



Figure 4.88: Center-Link Hook

### 4.4.6 Cutting Height

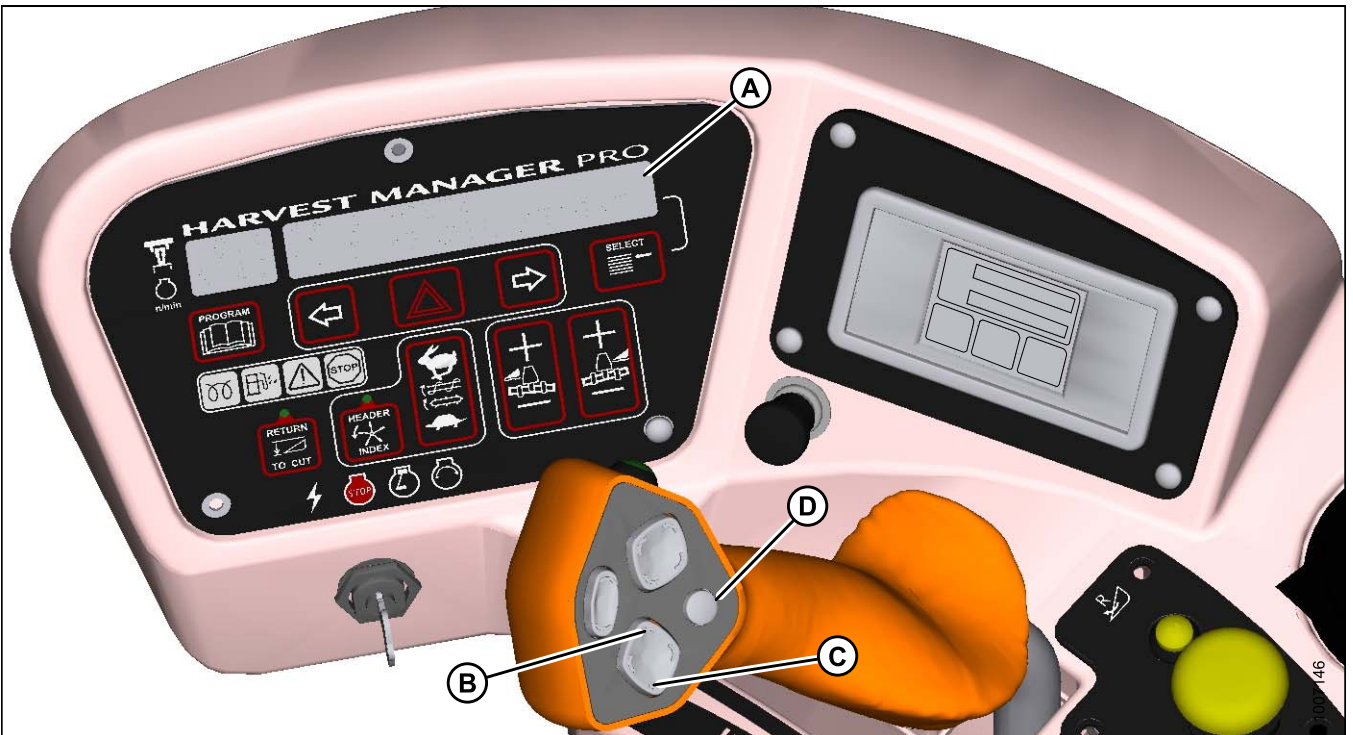

**Figure 4.89: Operator Console**

Cutting height is adjusted by raising or lowering the header with the **HEADER UP** (B) or **HEADER DOWN** (C) switches on the ground speed lever (GSL).

The cab display module (CDM) indicates header height with a reading on the **DISPLAY** (A) lower line between 00.0 and 10.0, with 00.0 being on the ground.

Use **DISPLAY SELECTOR** switch (D) to display the current setting.

#### *Return to Cut*

The monitoring system will assist you in maintaining the desired cutting height with the **RETURN TO CUT** feature. This feature can be turned **OFF** or **ON** with a switch on the cab display module (CDM).

The return to cut (RTC) feature provides preset cutting height and tilt angle settings for the header.

If desired, the CDM can be programmed so that only the cutting height feature is active.

The **AUTO RAISE HEIGHT** feature allows you to raise the header to a preselected height while in the **RETURN TO CUT** mode. Refer to [Programming the Auto Raise Height Feature, page 210](#).

## OPERATION

### Programming the Return to Cut Feature

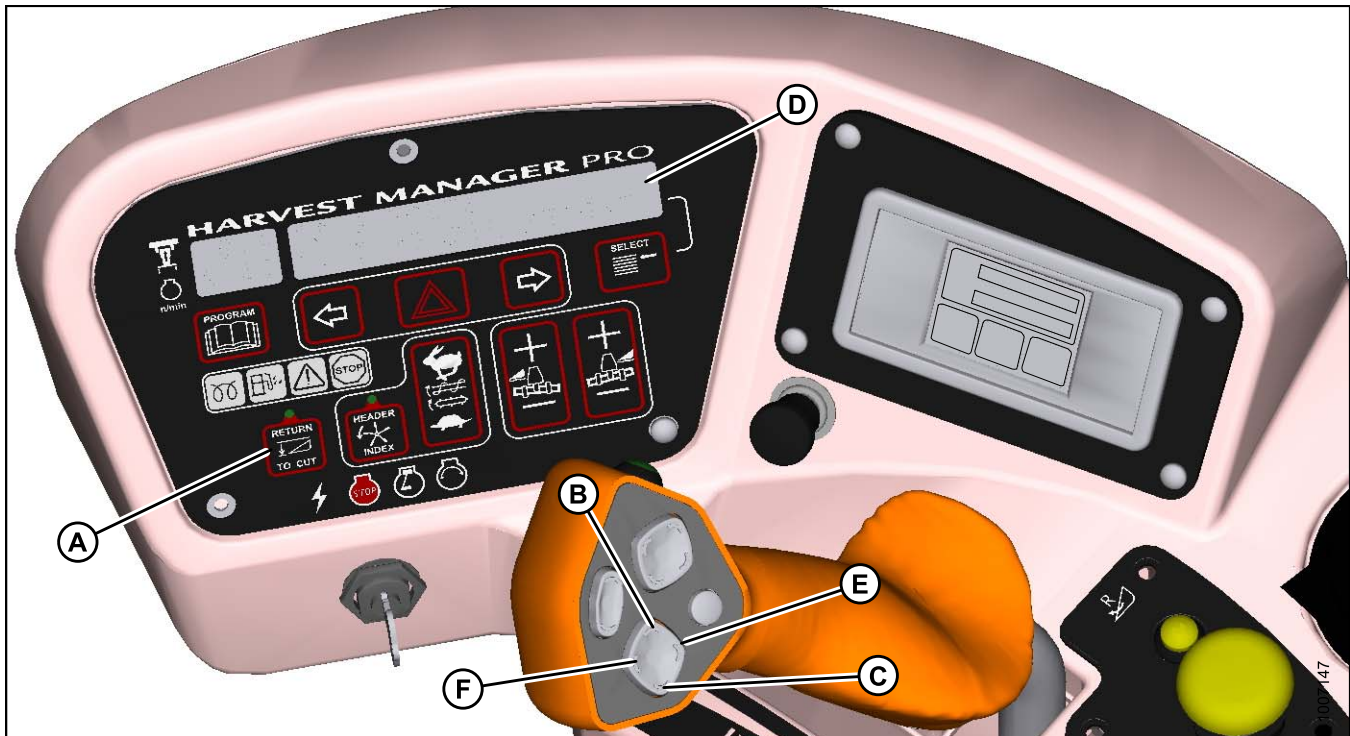

Figure 4.90: Operator Console

Program the return to cut (RTC) feature as follows:

### **CAUTION**

**Check to be sure all bystanders have cleared the area.**

1. Start windrower and engage the header.
2. Set RETURN TO CUT switch (A) to OFF (indicator light is OFF).
3. Adjust the header to the desired cutting height with the HEADER UP (B) or HEADER DOWN (C) switches on the ground speed lever (GSL). The cab display module (CDM) displays between **00.0 and 10.0** at (D).
4. Adjust the header angle with the HEADER TILT UP (E) or HEADER TILT DOWN (F) switches on the GSL. The CDM displays between **00.0 and 10.0**. This step is not required when height only has been preselected.
5. Press the RETURN TO CUT switch (A) on the CDM. The indicator light will illuminate and the settings are now programmed into the windrower control module (WCM).

## OPERATION

### Using the Return to Cut Feature

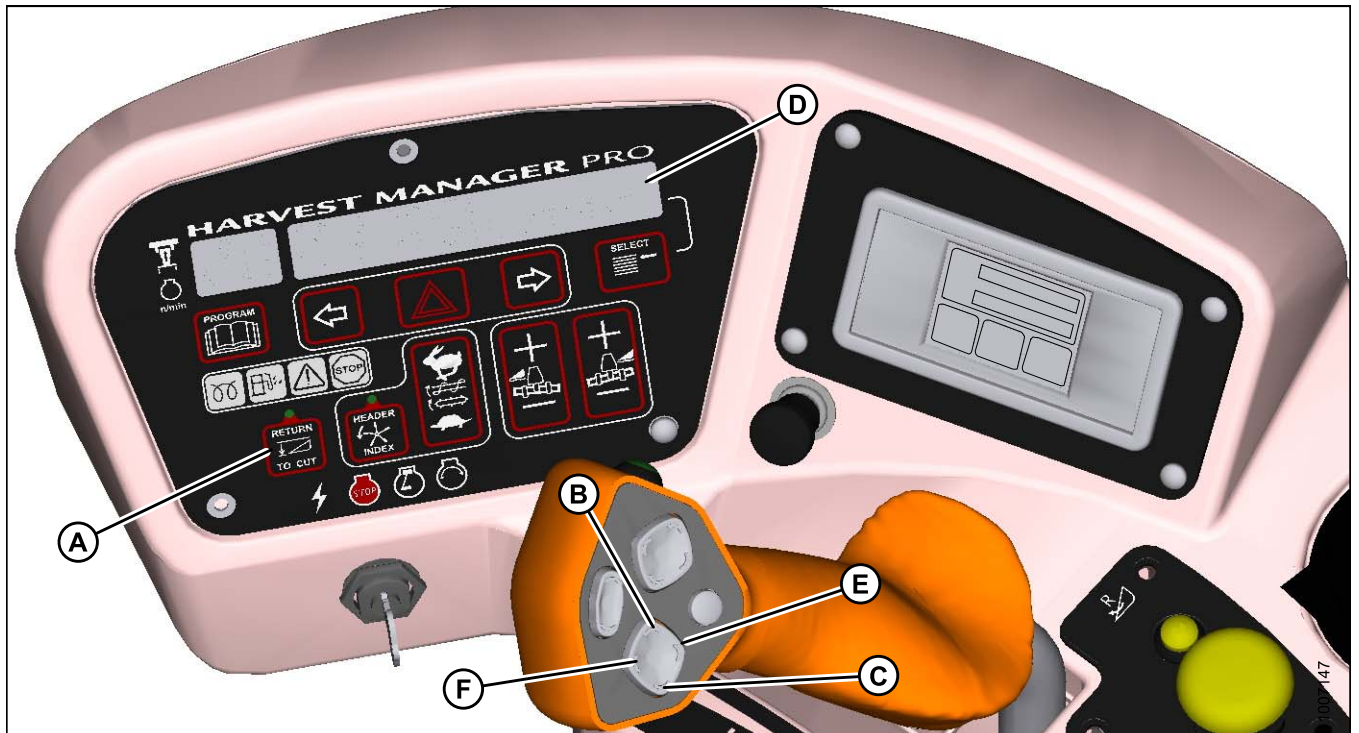

**Figure 4.91: Operator Console**

A - Return to Cut  
D - Display

B - Header Up  
E - Header Tilt Up

C - Header Down  
F - Header Tilt Down

Use the return to cut feature as follows:

#### **IMPORTANT:**

Ensure the header is engaged and the RETURN TO CUT switch (A) is illuminated.

#### **NOTE:**

The header can be raised or lowered by **pressing and holding** the HEADER UP (B) or HEADER DOWN (C) switches on the ground speed lever (GSL).

1. If header is above the preset cutting height, **momentarily press** HEADER DOWN switch (C) and the header will return to preset height.
2. If the header is below the preset height, **press and hold** the HEADER UP (B) switch to raise the header. Release switch to stop header. Alarm will sound when header rises past the preset height.
3. If the header angle changes, double-click (two clicks within 0.5 seconds) the HEADER TILT UP (E) or HEADER TILT DOWN switch (F) and the header will return to the preset angle.

#### **NOTE:**

If the header cannot return to the preset height or angle within 30 seconds, the return to cut feature will deactivate to prevent the hydraulic oil from overheating. Push the RETURN TO CUT switch (A) to reactivate.

## OPERATION

### Auto Raise Height

The header can be automatically raised if programmed into the cab display module (CDM).

Refer to the following topics:

- [Programming the Auto Raise Height Feature, page 210](#)
- [Using the Auto Raise Height Feature, page 211](#)

### Programming the Auto Raise Height Feature

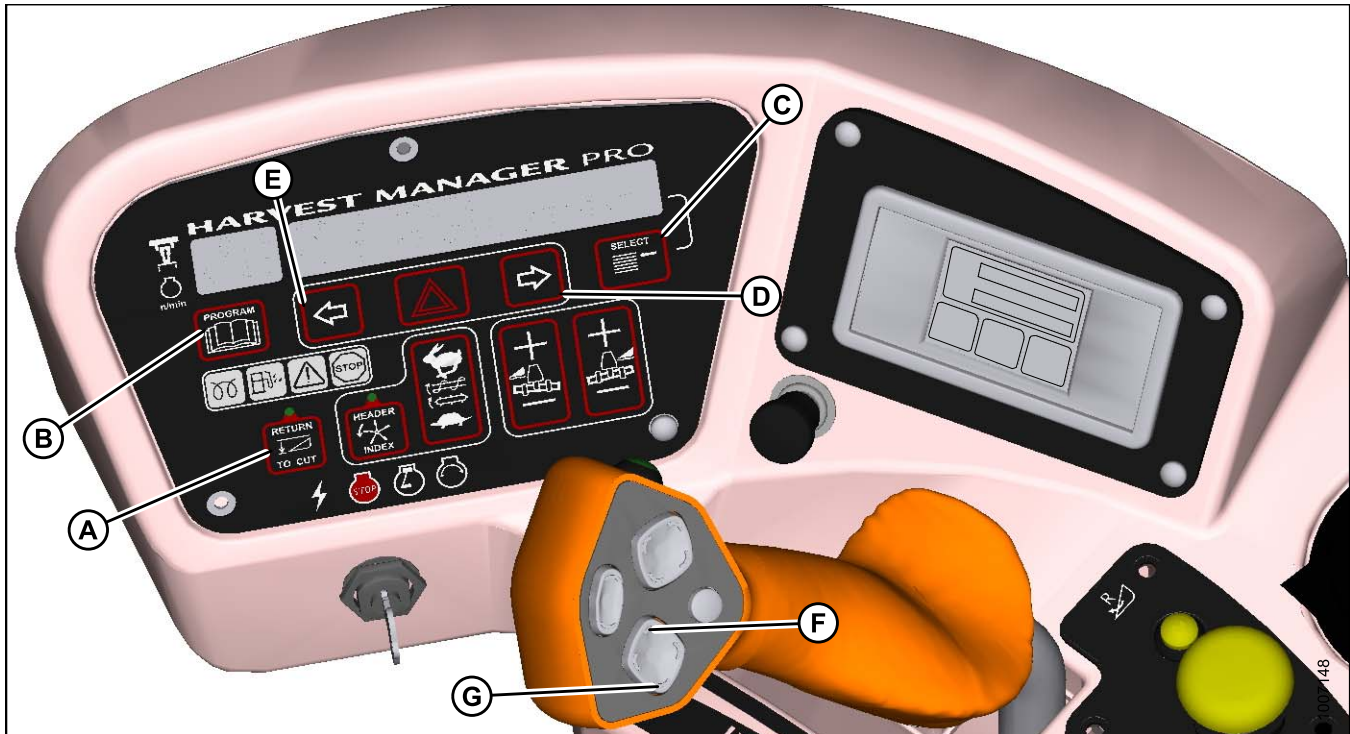

**Figure 4.92: Operator Console**

A - Return to Cut  
E - Left Arrow

B - Program  
F - Header Up

C - Select  
G - Header Down

D - Right Arrow

Program the auto raise height feature as follows:

#### NOTE:

RETURN TO CUT switch (A) can be OFF or ON.

1. Turn ignition ON or run engine.
2. Press PROGRAM (B) and SELECT (C) on cab display module (CDM) to enter programming mode.
3. Press SELECT (C). WINDROWER SETUP? is displayed on upper line (B).
4. Press right arrow (D), then SELECT. SET KNIFE SPEED? is displayed.
5. Press SELECT (C) until AUTO RAISE HEIGHT is displayed.
6. Press left arrow (E) or right arrow (D) to change value on lower line. Working range is 4.0 to 9.5. At 10.0, the feature is disabled and OFF is displayed.
7. When finished entering desired values, press PROGRAM to exit programming mode.

## OPERATION

### Using the Auto Raise Height Feature

#### **IMPORTANT:**

The windrower must be running with the header engaged at the cutting height and the RETURN TO CUT switch (A) activated.

Use the auto raise height feature as follows:

1. To raise the header to the auto raise height set point, double-click (two clicks within 0.5 seconds) the HEADER UP switch (B) on the ground speed lever (GSL).

#### **NOTE:**

With AUTO RAISE HEIGHT turned ON, the ACRE counter will be disabled when header height greater than preset cutting height.

2. If desired, press HEADER UP switch while header is being raised to disable auto raise height and maintain current height.

#### **NOTE:**

With AUTO RAISE HEIGHT turned OFF, the ACRE counter will be disabled when header height value is greater than 9.5. OFF is displayed on the cab display module (CDM).

3. To return the header to the preset cutting height, momentarily press HEADER DOWN switch (C).

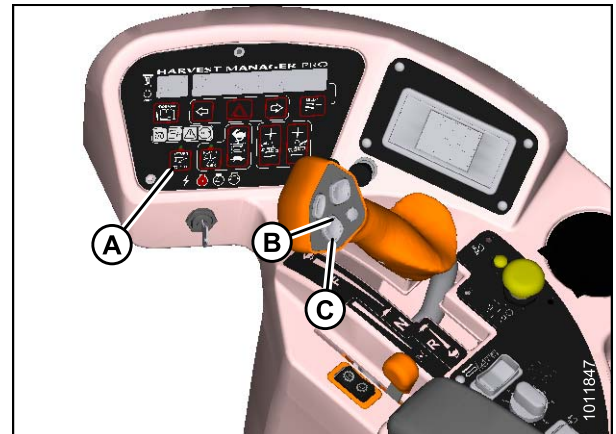

**Figure 4.93: Operator's Station**

### *Header Drop Rate*

The header should lower gradually when the HEADER DOWN switch is pressed. From full height to ground should take 3–4 seconds.

If the drop rate requires adjustment, refer to [Adjusting Header Drop Rate, page 395](#).

### 4.4.7 Double Windrowing

The double windrow attachment (DWA) deposits two windrows of conditioned material close together to be picked up by a forage chopper.

The system is for use with the A-Series Auger Header, R-Series Rotary Disc Header, and D65 Draper Header with HC10 Hay Conditioner.

The conditioned crop is deposited onto the side delivery system draper and delivered to the side of the windrower when required.

Raising the side delivery system shuts off the draper and allows the crop to be deposited between the windrower wheels as it would be without the side delivery system.

Refer to MacDon M-Series Windrower Double Windrow Attachment Manual for complete operating and maintenance instructions. The manual is shipped with the DWA kit.



Figure 4.94: DWA

#### *Double Windrow Attachment (DWA) Deck Position*

The deck is raised and lowered with the DWA UP (A) and DWA DOWN (B) switches on the ground speed lever (GSL) or with the rocker switch on the operator's console, depending on how the windrower cab display module (CDM) is programmed during the installation of the double windrow attachment (DWA).

To swap controls from the console to the GSL, refer to [Activating the Double Windrow Attachment \(DWA\), page 113](#).

**NOTE:**

The same switch is used for raising and lowering a swath roller (if installed).

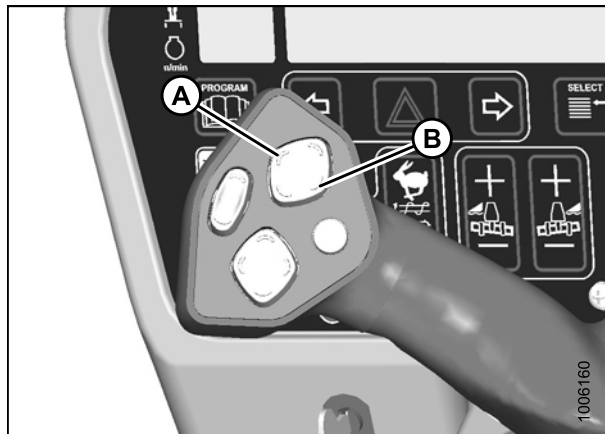

Figure 4.95: Ground Speed Lever (GSL)

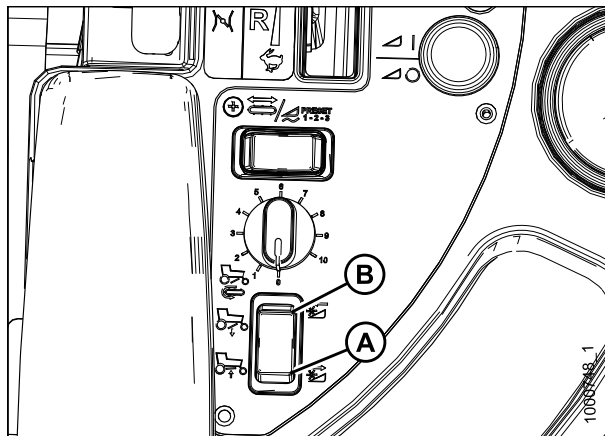

Figure 4.96: Operator's Console



## OPERATION

### *Double Windrow Attachment (DWA) Draper Speed*

The DWA draper speed is controlled with the rotary switch (A) next to the rocker switch on the operator's console.

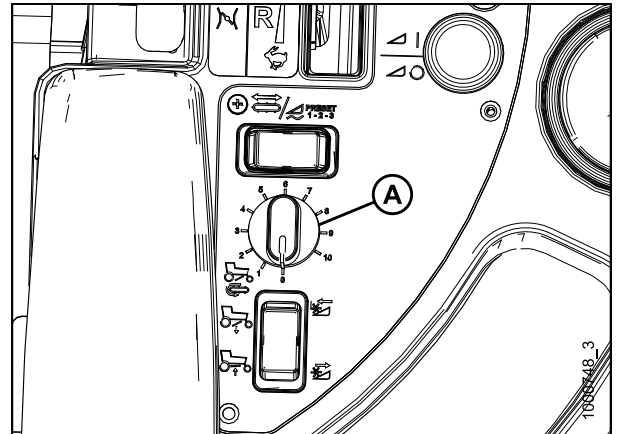
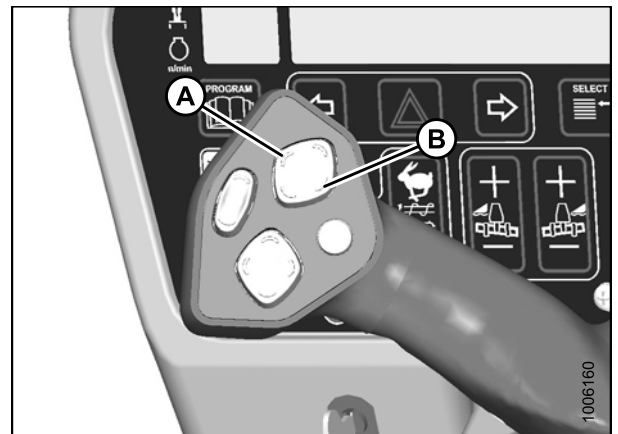

**Figure 4.97: Operator's Console**

### **4.4.8 Swath Roller Operation**

The swath roller is raised and lowered with the DWA UP (A) and DWA DOWN (B) switches on the ground speed lever (GSL) or with the rocker switch on the operator's console. This depends on how the windrower cab display module (CDM) is programmed during the installation of the Swath Roller kit.

To swap controls from the console to the GSL, refer to [Activating the Double Windrow Attachment \(DWA\)](#), page 113.



**Figure 4.98: GSL**

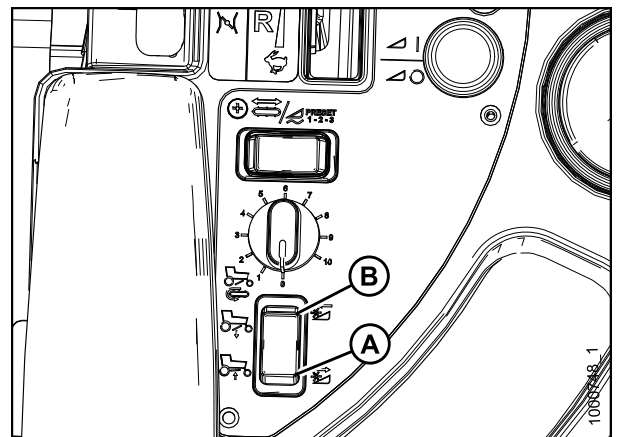

**Figure 4.99: Rocker Switch**

## 4.5 Attaching and Detaching Headers

### 4.5.1 Attaching a D-Series Header

D50, D60, and D65 headers can be attached to an M155E4 Self-Propelled Windrower.

Refer to the following instructions based on the type of center-link installed on your windrower:

- [Attaching a D-Series Header: Hydraulic Center-Link with Optional Self-Alignment, page 215](#)
- [Attaching a D-Series Header: Hydraulic Center-Link without Self-Alignment, page 220](#)

#### Attaching Header Boots

Header boots are required to attach a D-Series draper header to the windrower. Attach header boots (supplied with header) to windrower lift linkage if not already installed.

#### CAUTION

To prevent damage to the lift system when lowering header lift linkages without a header or weight box attached to the windrower, ensure the float engagement pin is installed in storage position (B) and NOT in engaged position (A).

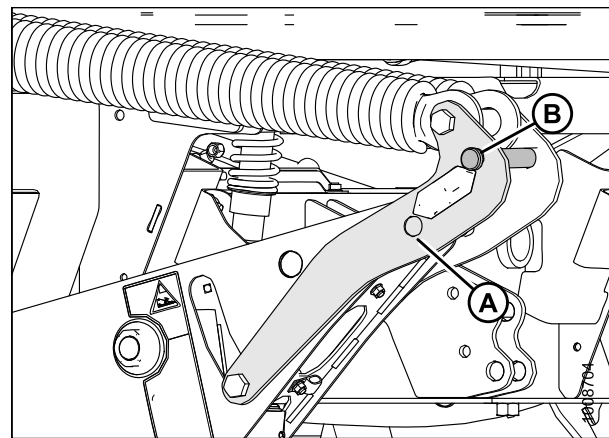

Figure 4.100: Header Float Linkage

1. Remove pin (B) from boot (A).

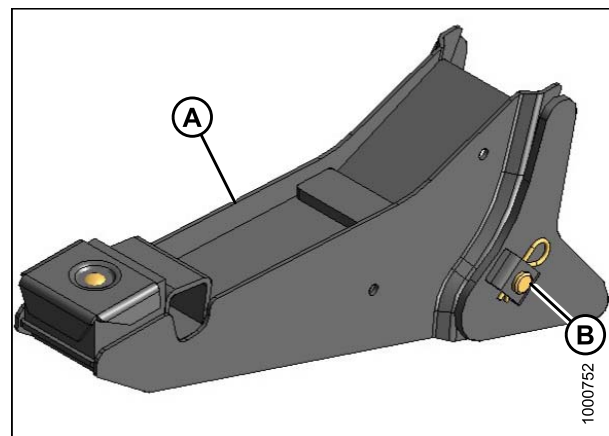

Figure 4.101: Header Boot

## OPERATION

2. Position boot (B) onto lift linkage (A) and reinstall pin (C). Pin may be installed from either side of boot.
3. Secure pin (C) with hairpin (D).
4. Repeat for opposite side.

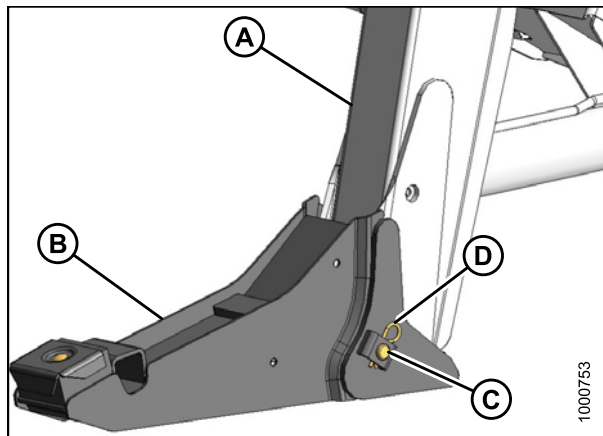

Figure 4.102: Header Boot

### *Attaching a D-Series Header: Hydraulic Center-Link with Optional Self-Alignment*

#### **NOTE:**

Draper header boots must be installed onto the windrower lift linkage before starting this procedure. Refer to [Attaching Header Boots, page 214](#).



#### **DANGER**

**To avoid bodily injury or death from unexpected startup of the machine, always stop the engine and remove the key from the ignition before leaving the operator's seat for any reason.**

1. Remove hairpin (A) from pins (B), and remove pins from both header legs.

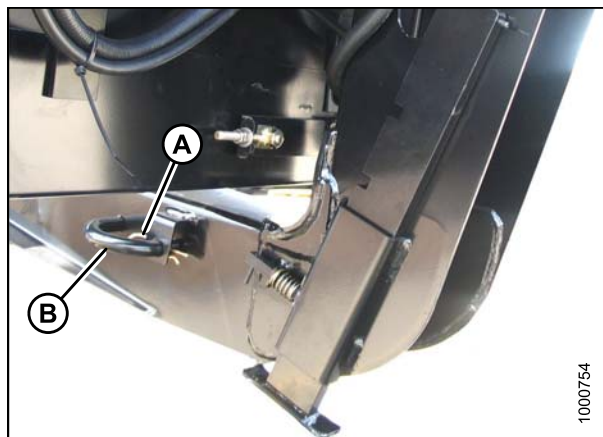

Figure 4.103: Header Leg

## OPERATION

### CAUTION

Check to be sure all bystanders have cleared the area.

#### **IMPORTANT:**

Remove protective cover from exhaust stack prior to starting engine.

2. Start the engine and activate the HEADER DOWN button (A) on the ground speed lever (GSL) to fully retract header lift cylinders.

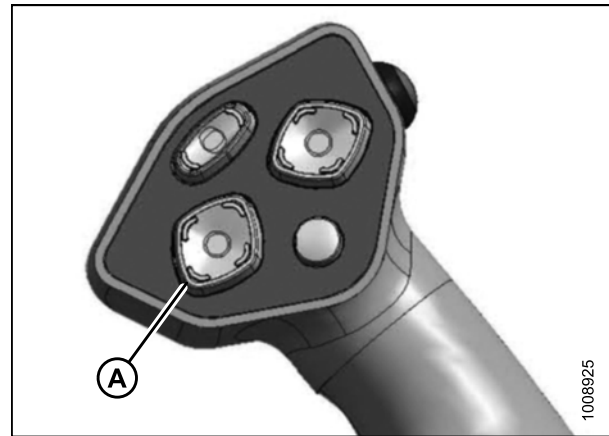

Figure 4.104: GSL

3. Activate the REEL UP switch (A) on the GSL to raise the center-link until the hook is above the attachment pin on the header.

#### **IMPORTANT:**

If the center-link is too low, it may contact the header as the windrower approaches the header for hookup.



Figure 4.105: GSL

4. Drive the windrower slowly forward until the boots (A) enter the header legs (B). Continue driving slowly forward until lift linkages contact the support plates in the header legs and the header nudges forward.
5. Ensure the lift linkages are properly engaged in the header legs and are contacting the support plates.

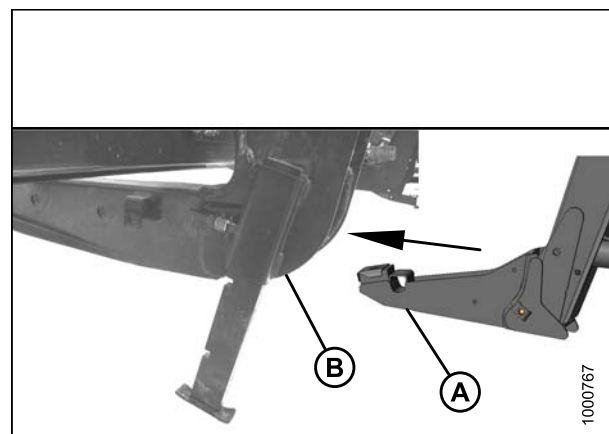

Figure 4.106: Header Leg and Boot

## OPERATION

6. Use the following GSL functions to position the center-link hook above the header attachment pin:
  - Reel up (A) to raise the center-link
  - Reel down (B) to lower the center-link
  - Header tilt up (C) to retract the center-link
  - Header tilt down (D) to extend the center-link

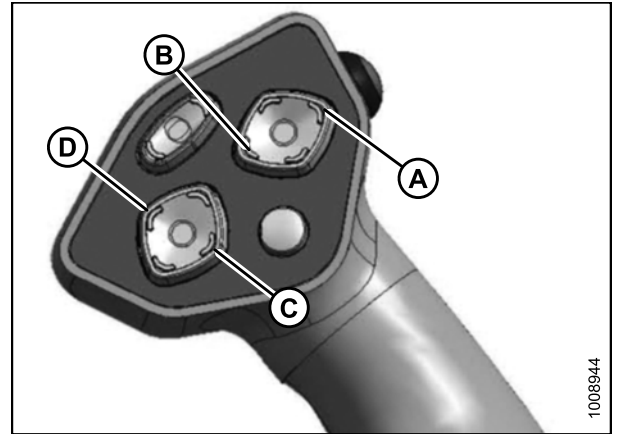

Figure 4.107: GSL

7. Adjust position of the center-link cylinder (A) with the reel up, reel down, and header tilt switches on the GSL until the hook is above the header attachment pin.

**IMPORTANT:**

Hook release must be down to enable self-locking mechanism. If the release is open (up), manually push it down after hook engages header pin.

8. Lower center-link (A) onto the header with the reel down switch on the GSL until it locks into position (hook release [B] is down).
9. Check that center-link is locked onto header by pressing the reel up switch on the GSL.

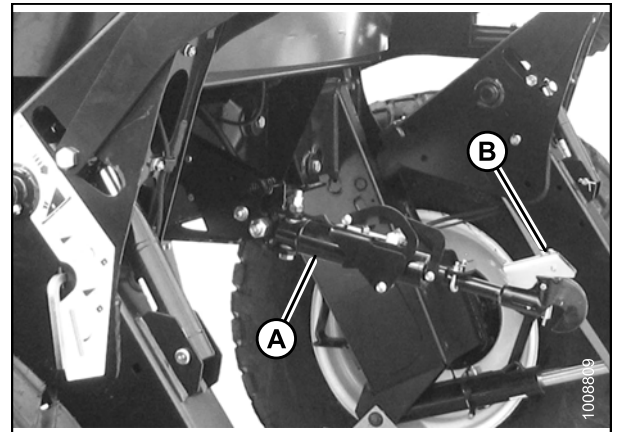

Figure 4.108: Hydraulic Center-Link

**CAUTION**

Check to be sure all bystanders have cleared the area.

10. Press the header up switch (A) to raise header to maximum height.

**NOTE:**

If one end of the header does **NOT** fully raise, rephase the lift cylinders as follows:

- a. Press and hold the header up switch until both cylinders stop moving.
- b. Continue to hold the switch for 3–4 seconds. Cylinders are now phased.

**NOTE:**

It may be necessary to repeat this procedure if there is air in the system.

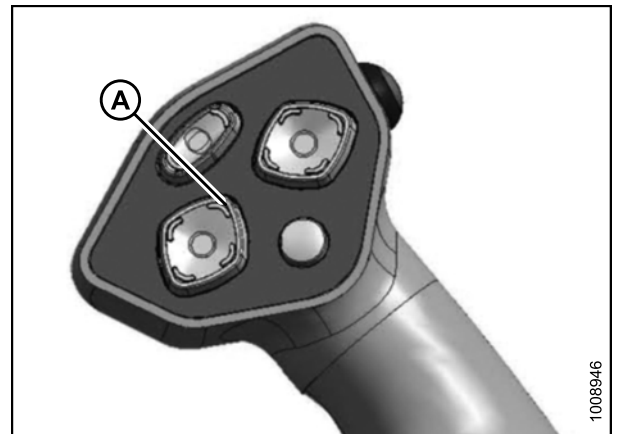
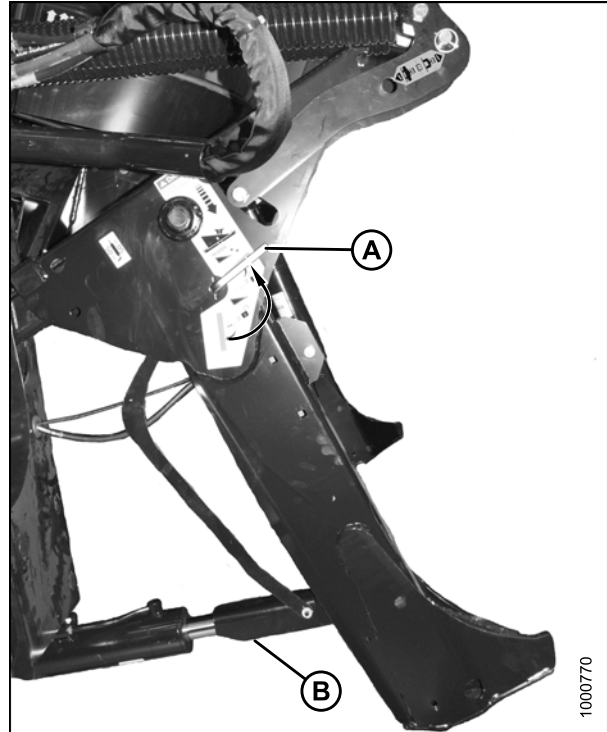

Figure 4.109: GSL

## OPERATION

11. Engage safety props on both lift cylinders as follows:
  - a. Stop engine and remove key from ignition.
  - b. Pull lever (A) and rotate towards the header to release and lower safety prop (B) onto the lift cylinder.
  - c. Repeat for opposite lift cylinder.



**Figure 4.110: Safety Prop**

12. Install pin (B) through the header leg (engaging U-bracket in lift linkage) on both sides and secure with hairpin (A).
13. Raise header stand (D) to storage position by pulling spring pin (C) and lifting stand into uppermost position. Release spring pin.

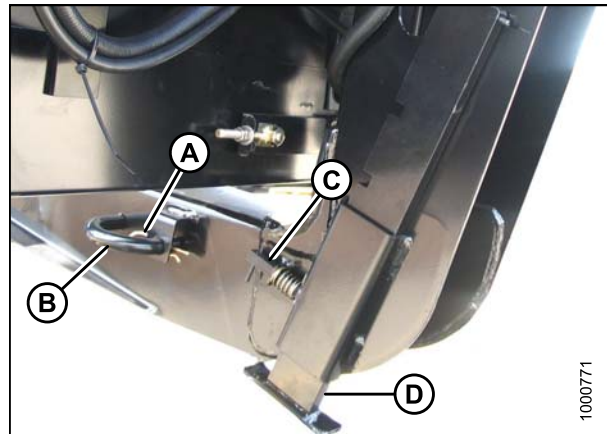

**Figure 4.111: Header Leg**

## OPERATION

14. Remove clevis pin from storage position (B) in linkage and insert into hole (A) to engage float springs. Secure with hairpin.

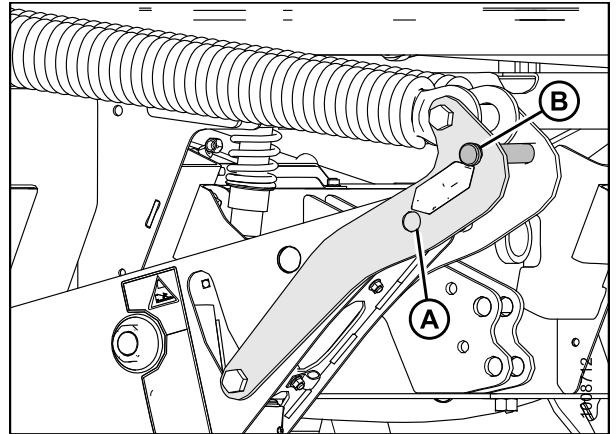

Figure 4.112: Header Float Linkage

15. Disengage safety prop by turning lever (A) downwards to release and lower stop until lever locks into vertical position.
16. Repeat for opposite safety prop.

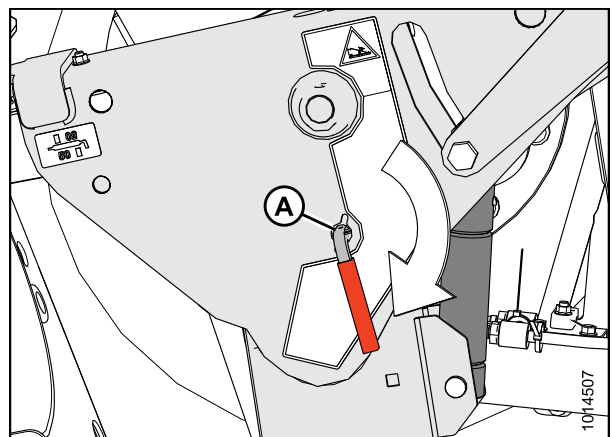

Figure 4.113: Safety Prop

### CAUTION

Check to be sure all bystanders have cleared the area.

17. Start the engine and activate the header down switch (A) on the GSL to fully lower the header.
18. Stop engine and remove key from ignition.

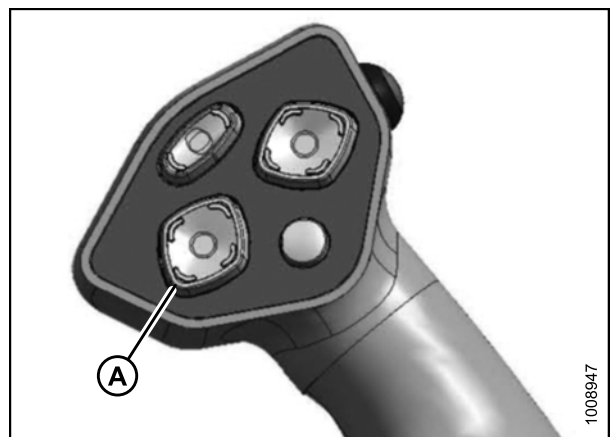

Figure 4.114: GSL

## OPERATION

19. Connect header drive hoses (A) and electrical harness (B) to header. Refer to the draper header operator's manual.

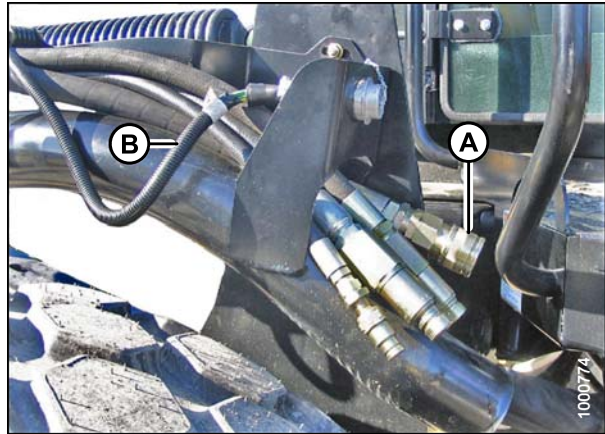

Figure 4.115: Header Drive Hoses and Harness

20. Connect reel hydraulics (A) at right cab-forward side of windrower. Refer to the draper header operator's manual.

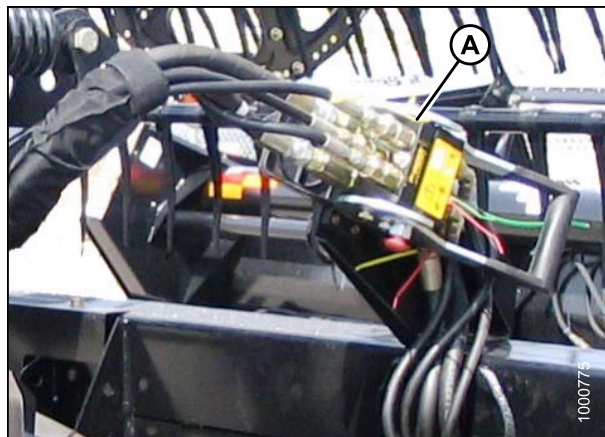

Figure 4.116: Reel Hydraulics

### *Attaching a D-Series Header: Hydraulic Center-Link without Self-Alignment*

#### **NOTE:**

Draper header boots must be installed onto the windrower lift linkage before starting this procedure. Refer to [Attaching Header Boots, page 214](#).

#### **⚠ DANGER**

To avoid bodily injury or death from unexpected startup of the machine, always stop the engine and remove the key from the ignition before leaving the operator's seat for any reason.



## OPERATION

1. Remove hairpin (A) from pins (B), and remove pins from both header legs.

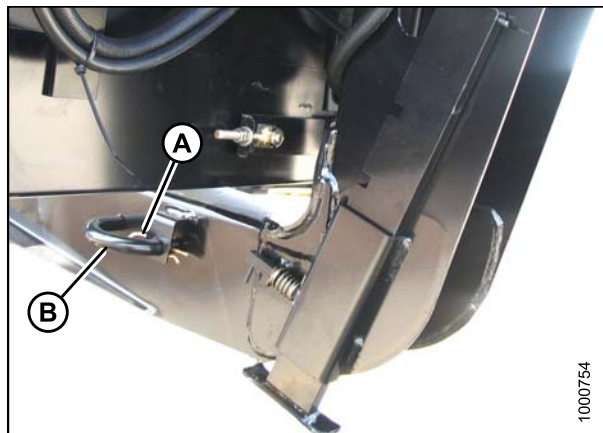

Figure 4.117: Header Leg

### CAUTION

Check to be sure all bystanders have cleared the area.

#### **IMPORTANT:**

Remove protective cover from exhaust stack prior to starting engine.

2. Start the engine and activate the HEADER DOWN button (A) on the ground speed lever (GSL) to fully retract header lift cylinders.

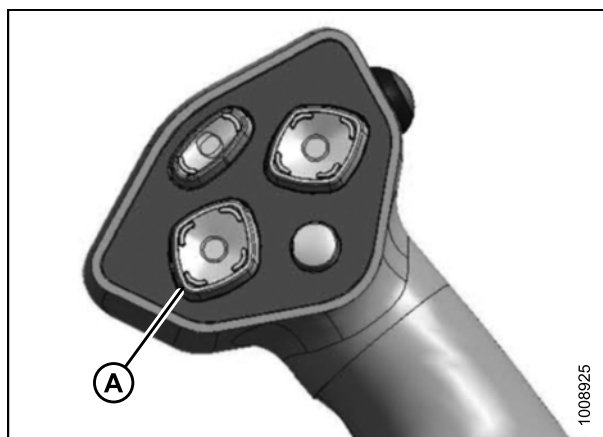

Figure 4.118: GSL

3. Relocate pin (A) in frame linkage as required to raise the center-link (B) until the hook is above the attachment pin on the header.

#### **IMPORTANT:**

If the center-link is too low, it may contact the header as the windrower approaches the header for hookup.

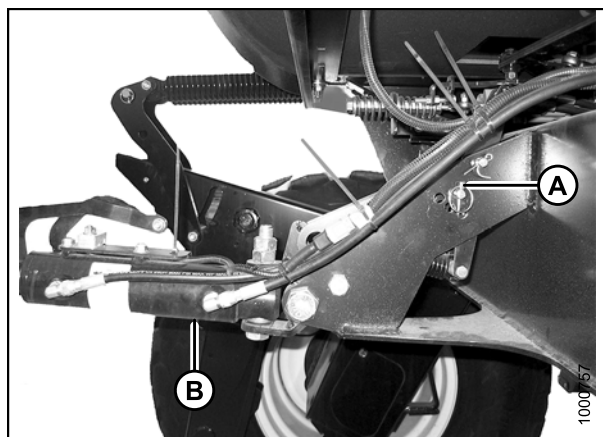

Figure 4.119: Hydraulic Center-Link without Self-Alignment Kit

## OPERATION

4. Drive the windrower slowly forward until the boots (A) enter the header legs (B). Continue driving slowly forward until lift linkages contact the support plates in the header legs and the header nudges forward.
5. Ensure the lift linkages are properly engaged in the header legs and are contacting the support plates.

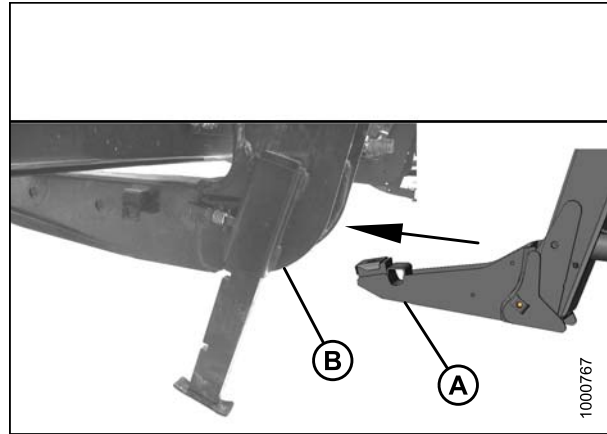

Figure 4.120: Header Leg and Boot

6. Use the following GSL functions to position the center-link hook above the header attachment pin:
  - Header tilt up (A) to retract the center-link
  - Header tilt down (B) to extend the center-link
7. Stop engine and remove key from ignition.

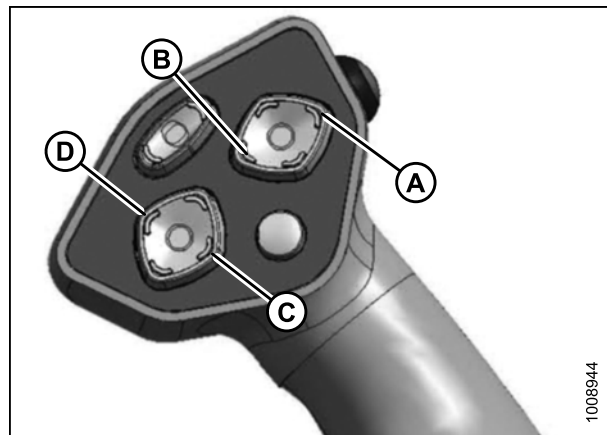

Figure 4.121: GSL

8. Push down on rod end of link cylinder (B) until hook engages and locks onto header pin.

**IMPORTANT:**

Hook release must be down to enable self-locking mechanism. If the release is open (up), manually push it down after hook engages header pin.

9. Check that center-link (A) is locked onto header by pulling upward on rod end (B) of cylinder.

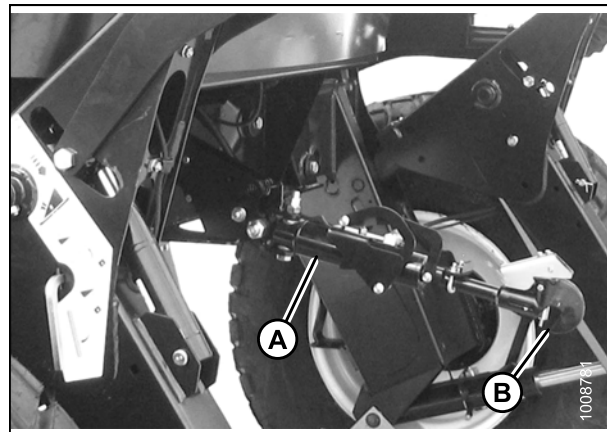

Figure 4.122: Hydraulic Center-Link

## OPERATION

### CAUTION

Check to be sure all bystanders have cleared the area.

10. Start the engine.
11. Press the header up switch (A) to raise header to maximum height.

#### NOTE:

If one end of the header does **NOT** fully raise, rephase the lift cylinders as follows:

- a. Press and hold the header up switch until both cylinders stop moving.
- b. Continue to hold the switch for 3–4 seconds. Cylinders are now phased.

#### NOTE:

It may be necessary to repeat this procedure if there is air in the system.

12. Engage safety props on both lift cylinders as follows:
  - a. Stop engine and remove key from ignition.
  - b. Pull lever (A) and rotate towards the header to release and lower safety prop (B) onto the lift cylinder.
  - c. Repeat for opposite lift cylinder.

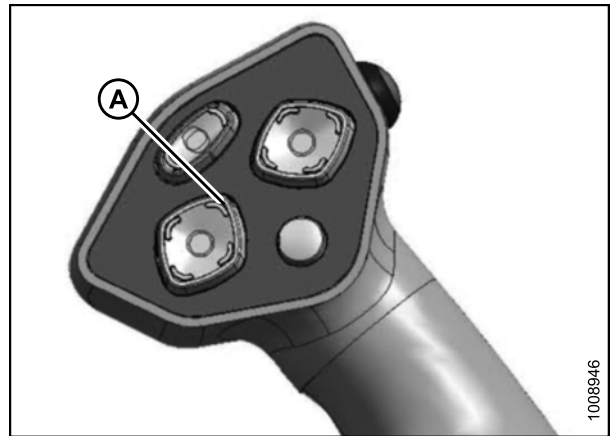

Figure 4.123: GSL

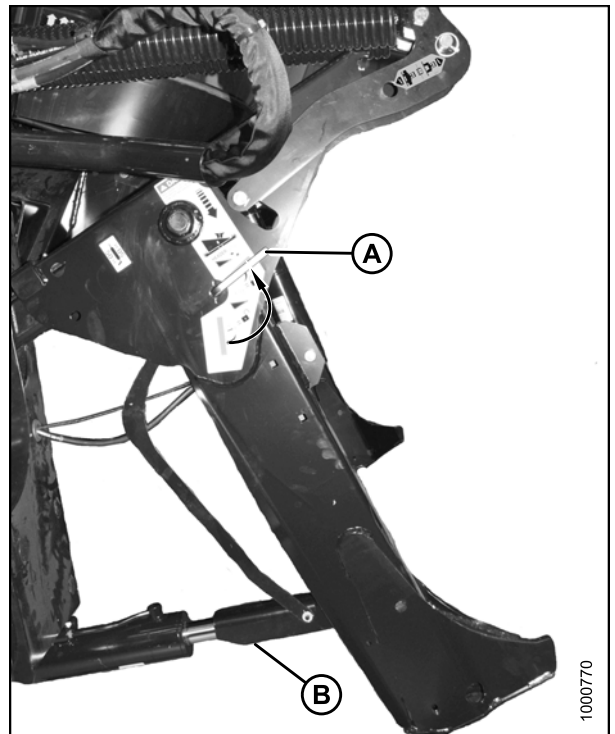

Figure 4.124: Safety Prop

## OPERATION

13. Install pin (B) through the header leg (engaging U-bracket in lift linkage) on both sides and secure with hairpin (A).
14. Raise header stand (D) to storage position by pulling spring pin (C) and lifting stand into uppermost position. Release spring pin.

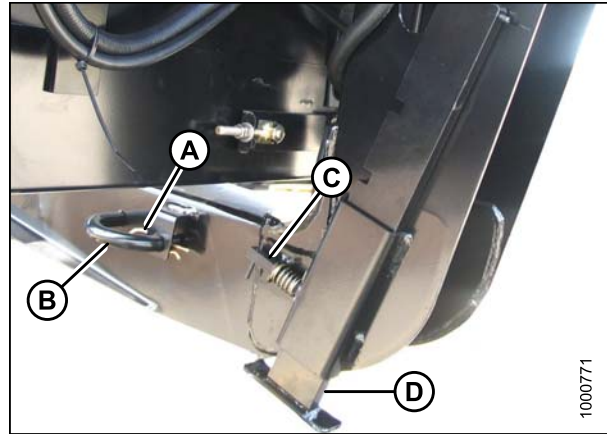

Figure 4.125: Header Leg

15. Remove clevis pin from storage position (B) in linkage and insert into hole (A) to engage float springs. Secure with hairpin.

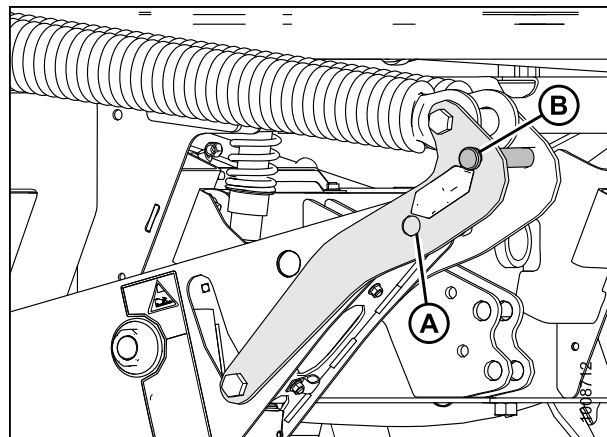

Figure 4.126: Header Float Linkage

16. Disengage safety prop by turning lever (A) downwards to release and lower stop until lever locks into vertical position.
17. Repeat for opposite safety prop.

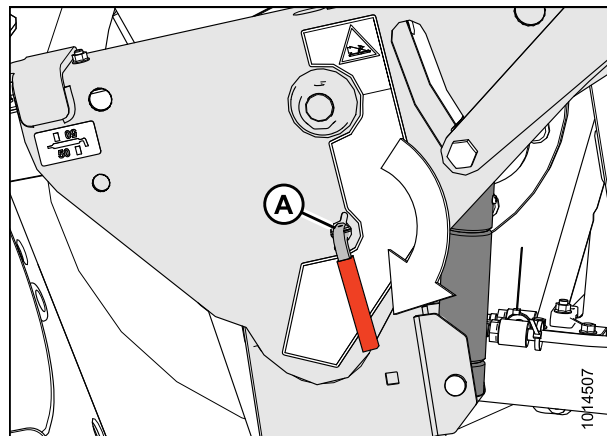

Figure 4.127: Safety Prop

## OPERATION

### CAUTION

Check to be sure all bystanders have cleared the area.

18. Start the engine and activate the header down switch (A) on the GSL to fully lower the header.
19. Stop engine and remove key from ignition.

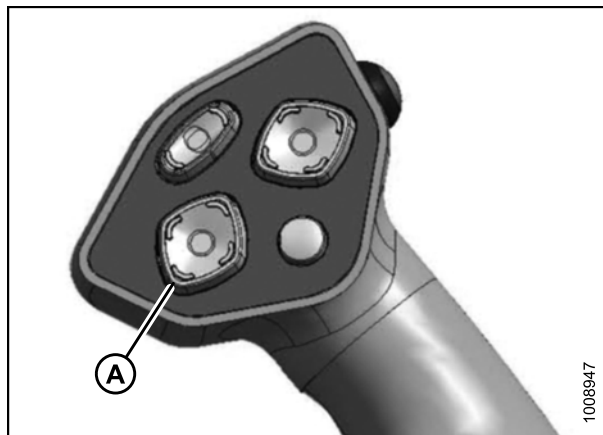

Figure 4.128: GSL

20. Connect header drive hoses (A) and electrical harness (B) to header. Refer to the draper header operator's manual.

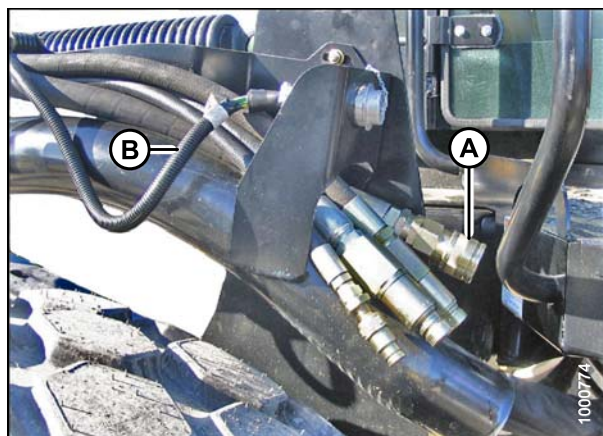

Figure 4.129: Header Drive Hoses and Harness

21. Connect reel hydraulics (A) at right cab-forward side of windrower. Refer to the draper header operator's manual.

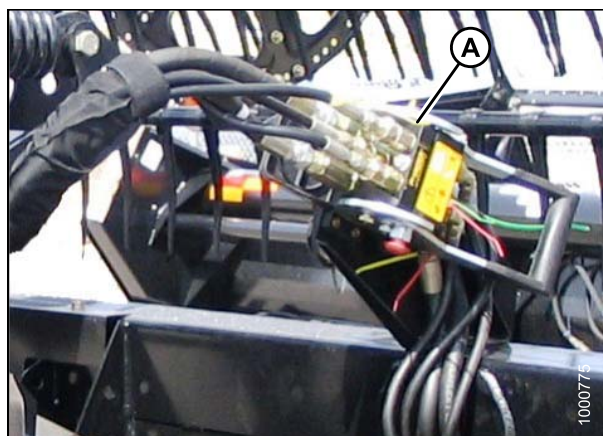

Figure 4.130: Reel Hydraulics

## 4.5.2 Detaching a D-Series Header

### *Detaching a D-Series Header: Hydraulic Center-Link*

#### **⚠ DANGER**

To avoid bodily injury or death from unexpected startup of the machine, always stop the engine and remove the key from the ignition before leaving the operator's seat for any reason.

1. Start engine and press header up (A) switch to raise header to maximum height.
2. Rephase cylinders if one end of the header does not raise fully. If rephasing is required, proceed as follows:
  - a. Press and hold the header up (A) switch until both cylinders stop moving.
  - b. Continue to hold the switch for 3–4 seconds. Cylinders are now phased.
3. Stop engine and remove key.
4. Pull lever (A) and rotate toward header to lower safety prop (B) onto cylinder. Repeat for opposite cylinder.

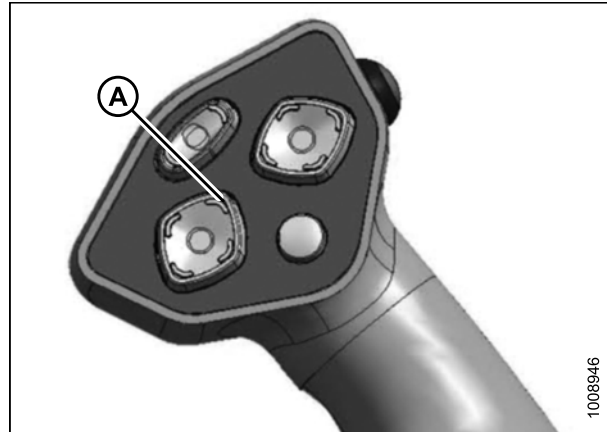

Figure 4.131: GSL

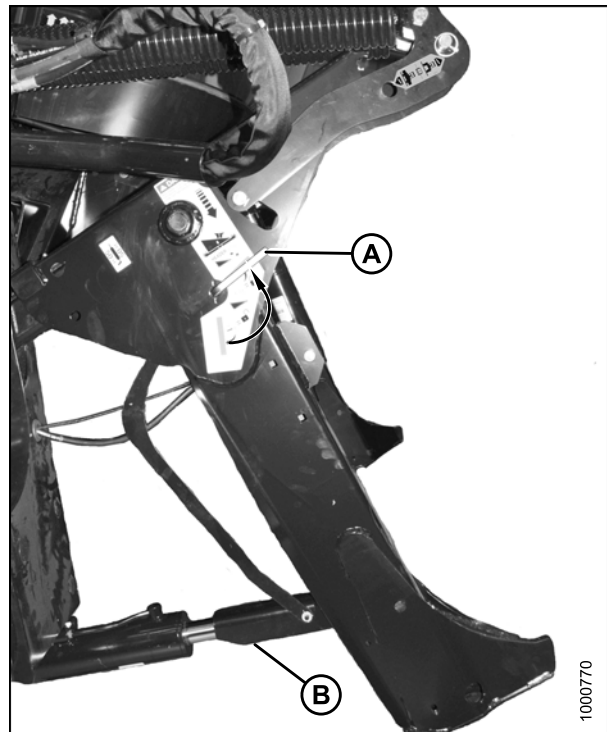

Figure 4.132: Safety Prop

## OPERATION

5. Remove the pin (B) by removing the hairpin (A) from header leg on both sides.
6. Lower header stand (D) by pulling spring loaded pin (C). Release spring pin to lock stand.

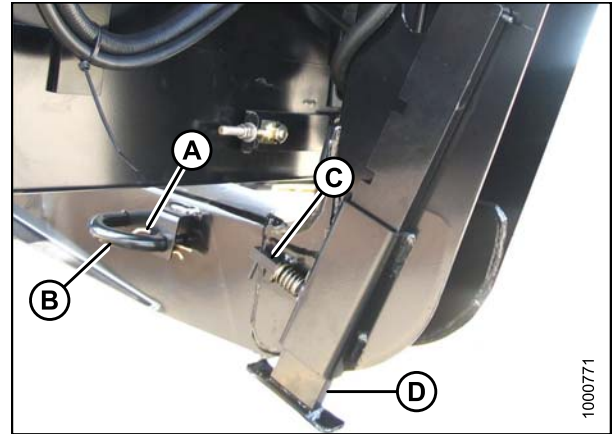

Figure 4.133: Header Stand

7. Remove clevis pin from location (A) to disengage float springs and insert in storage hole (B). Secure with lynch pin.

### CAUTION

To prevent damage to the lift system when lowering header lift linkages without a header or weight box attached to the windrower, ensure the float engagement pin is installed in storage position (B) and NOT in engaged position (A).

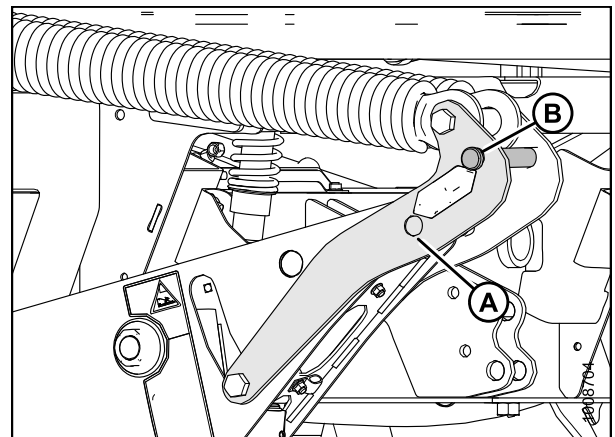

Figure 4.134: Header Float Linkage

8. Disengage safety props by turning lever (A) away from header to raise safety prop until lever locks into vertical position. Repeat for opposite cylinder.
9. Start engine, choose a level area, and lower header to the ground.
10. Stop the engine and remove the key.

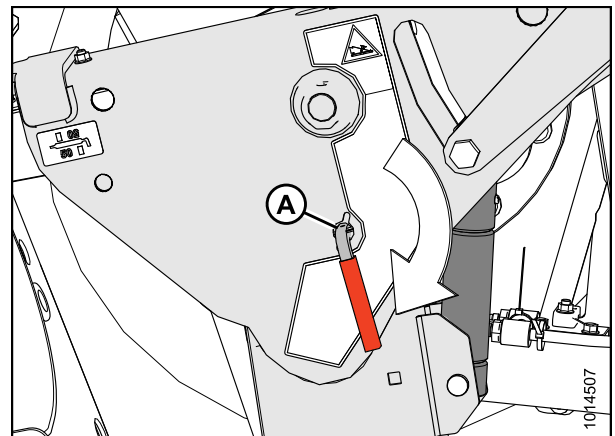

Figure 4.135: Safety Prop

## OPERATION

11. Disconnect header drive hydraulics (A) and electrical harness (B) from header and store in support on windrower left cab-forward side. Refer to the draper header operator's manual for further information.

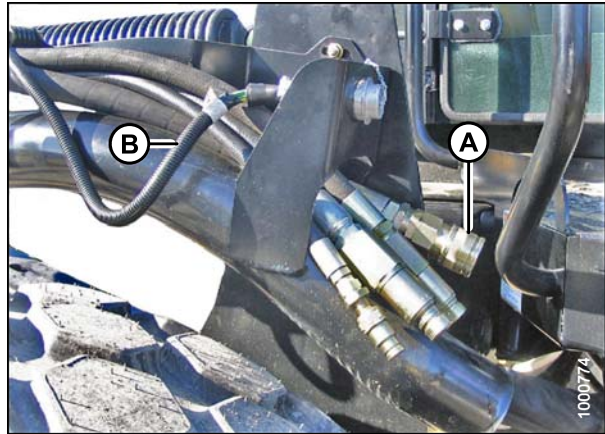

Figure 4.136: Header Drive Hydraulics

12. Disconnect reel hydraulics (A) from header and store on bracket at windrower left cab-forward side. Refer to the draper header operator's manual for further information.

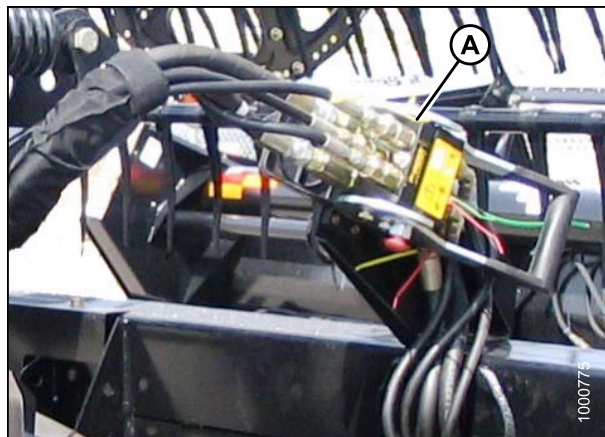

Figure 4.137: Reel Hydraulics

### CAUTION

Check to be sure all bystanders have cleared the area.

13. Start engine and activate header tilt up (A) and header tilt down (B) cylinder switches on ground speed lever (GSL) to release load on center-link cylinder.

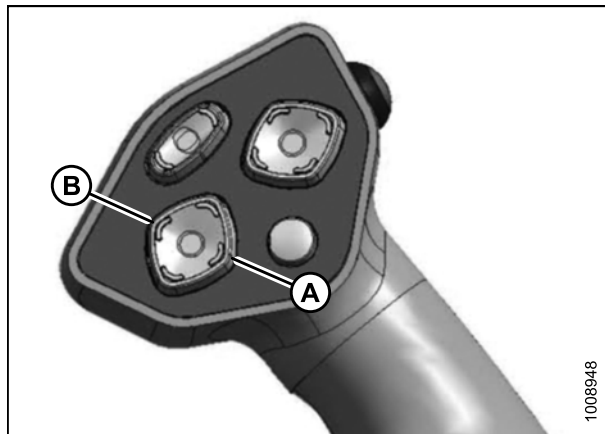

Figure 4.138: GSL



## OPERATION

14. Disconnect center-link by lifting release (B) and lift hook (A) off header.

**NOTE:**

If optional center-link self-alignment kit is installed, lift release (B) and then operate the link lift cylinder with REEL UP switch on GSL to disengage the center-link from the header.

**NOTE:**

If hay conditioner is installed, watch clearances on both sides.

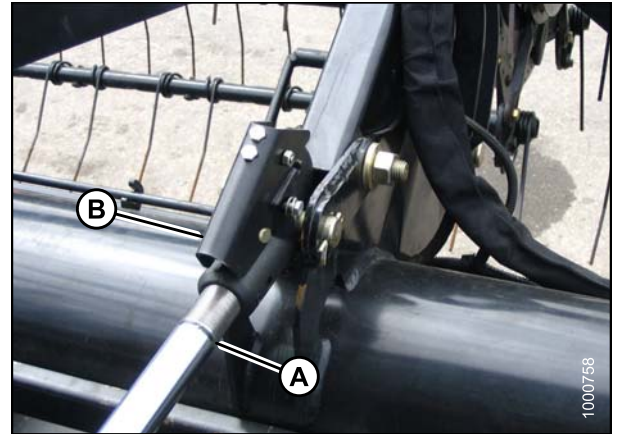

**Figure 4.139: Hydraulic Center-Link**

15. Reinstall pin (A) into header leg and secure with a hairpin (B).

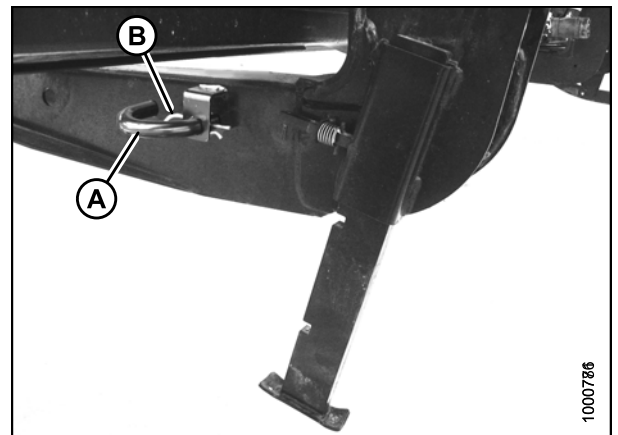

**Figure 4.140: Header Stand**

### 4.5.3 Attaching an A-Series Header

A30-D, A30-S, and A40-D headers can be attached to an M155E4 Self-Propelled Windrower.

Refer to the following instructions based on the type of center-link installed on your windrower:

- [Attaching an A-Series Header: Hydraulic Center-Link with Optional Self-Alignment, page 230](#)
- [Attaching an A-Series Header: Hydraulic Center-Link without Self-Alignment, page 235](#)

## OPERATION

### Attaching an A-Series Header: Hydraulic Center-Link with Optional Self-Alignment

#### DANGER

To avoid bodily injury or death from unexpected startup of the machine, always stop the engine and remove the key from the ignition before leaving the operator's seat for any reason.

1. Remove hairpin (A) from clevis pin (B) and remove clevis pin from the header boots (C) on both sides of the header.

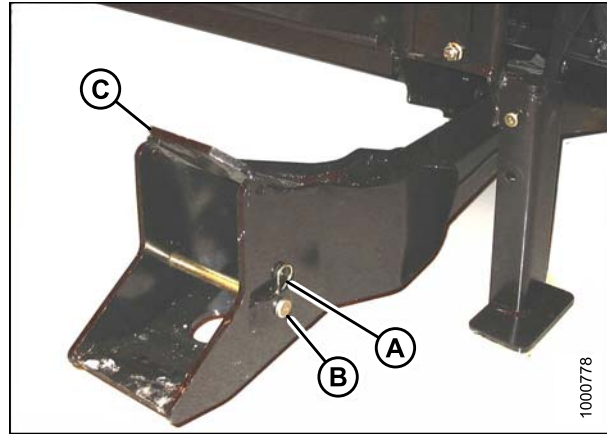

Figure 4.141: Header Boot

#### CAUTION

To prevent damage to the lift system when lowering header lift linkages without a header or weight box attached to the windrower, ensure the float engagement pin is installed in storage position (B) and NOT in engaged position (A).

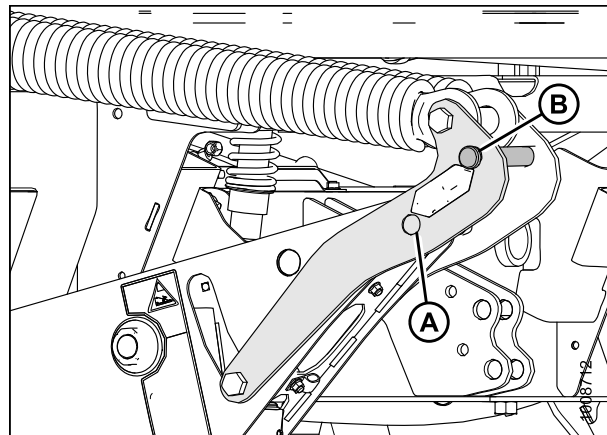

Figure 4.142: Header Float Linkage

#### CAUTION

Check to be sure all bystanders have cleared the area.

##### IMPORTANT:

Remove protective cover from exhaust stack prior to starting engine.

2. Start the engine and activate the HEADER DOWN button (A) on the ground speed lever (GSL) to fully retract header lift cylinders.

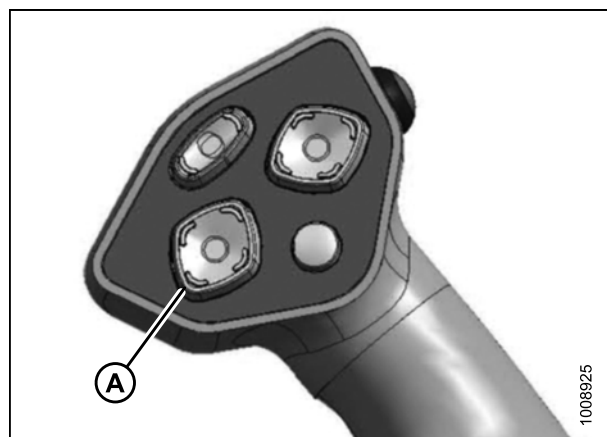

Figure 4.143: GSL

## OPERATION

3. Activate the reel up switch (A) on the GSL to raise the center-link until the hook is above the attachment pin on the header.

**IMPORTANT:**

If the center-link is too low, it may contact the header as the windrower approaches the header for hookup.

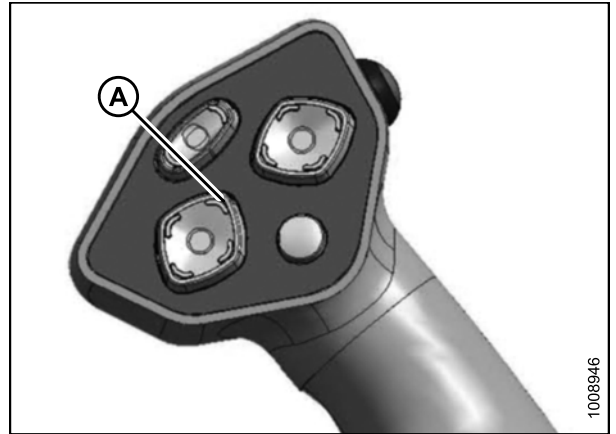

Figure 4.144: GSL

4. Drive the windrower slowly forward until the windrower feet (A) enter the header boots (B). Continue driving slowly forward until the feet engage the boots and the header nudges forward.

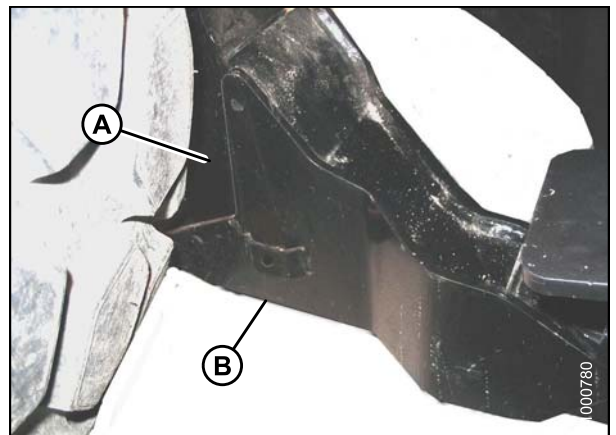

Figure 4.145: Header Boot

5. Use the following GSL functions to position the center-link hook above the header attachment pin:
  - Reel up (A) to raise the center-link
  - Reel down (B) to lower the center-link
  - Header tilt up (C) to retract the center-link
  - Header tilt down (D) to extend the center-link

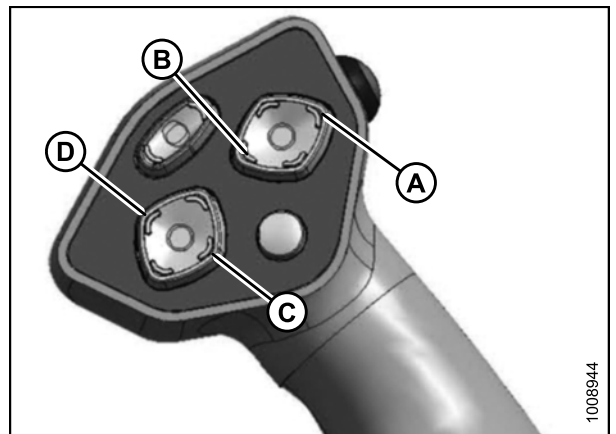

Figure 4.146: GSL

## OPERATION

- Adjust position of the center-link cylinder (A) with the reel up and reel down switches on the GSL until the hook is positioned above the header attachment pin.

### IMPORTANT:

Hook release must be down to enable self-locking mechanism. If the release is open (up), manually push it down after hook engages header pin.

- Lower center-link (A) onto the header with reel down switch until it locks into position (hook release [B] is down).
- Check that center-link is locked onto header by pressing the reel up switch on the GSL.

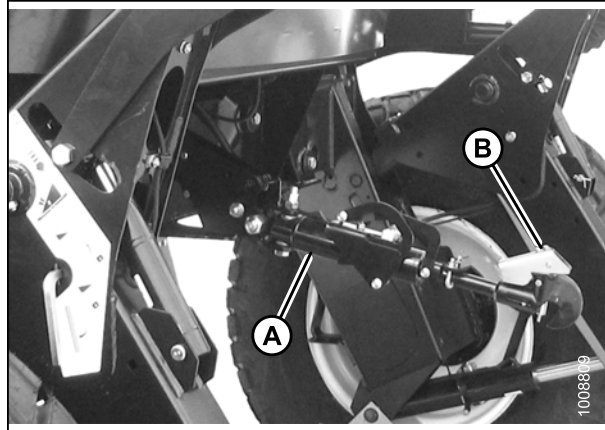

Figure 4.147: Hydraulic Center-Link

## CAUTION

Check to be sure all bystanders have cleared the area.

- Press the header up switch (A) to raise header to maximum height.

### NOTE:

If one end of the header does **NOT** fully raise, rephase the lift cylinders as follows:

- Press and hold the header up switch until both cylinders stop moving.
- Continue to hold the switch for 3–4 seconds. Cylinders are now phased.

### NOTE:

It may be necessary to repeat this procedure if there is air in the system.



Figure 4.148: GSL

## OPERATION

10. Engage safety props on both lift cylinders as follows:
  - a. Stop engine and remove key from ignition.
  - b. Pull lever (A) and rotate towards the header to release and lower safety prop (B) onto the lift cylinder.
  - c. Repeat for opposite lift cylinder.

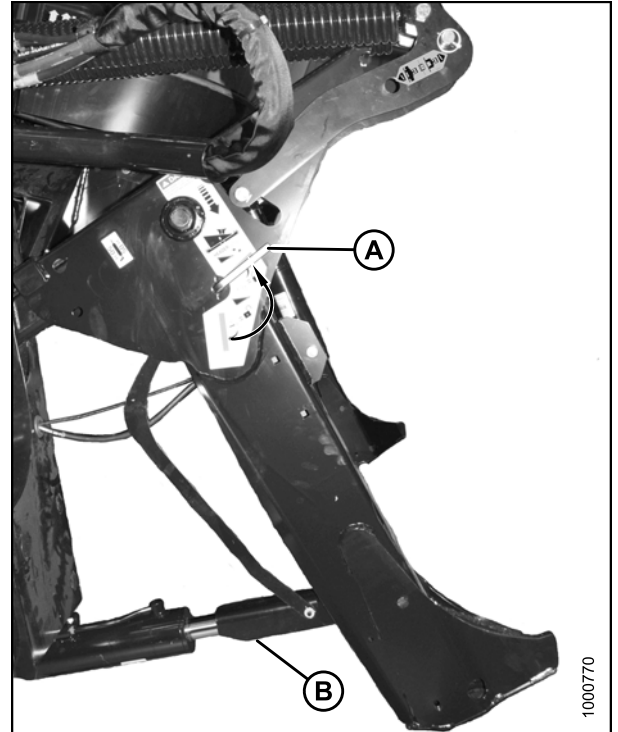

Figure 4.149: Safety Prop

11. Install clevis pin (A) through boot and foot and secure with hairpin. Repeat for opposite boot.

**IMPORTANT:**

Ensure clevis pin (A) is fully inserted and hairpin is installed behind bracket.

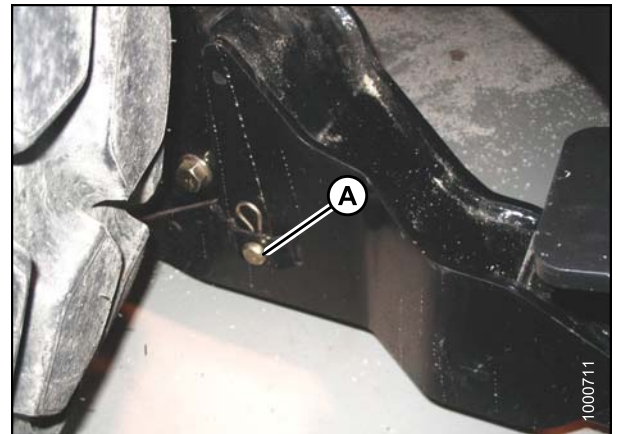
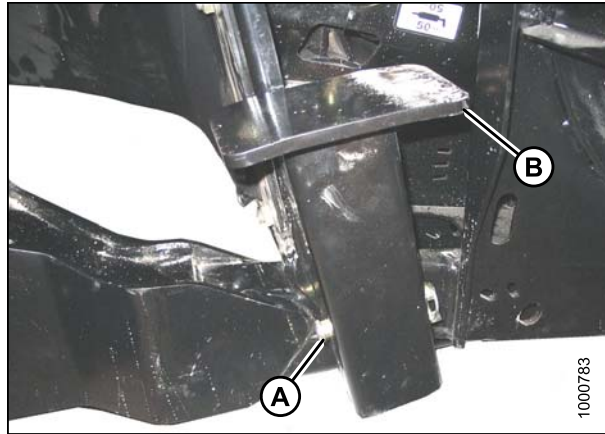

Figure 4.150: Header Boot

## OPERATION

12. Remove lynch pin from clevis pin (A) in stand (B).
13. Hold stand (B) and remove pin (A).
14. Move stand (B) to storage position by inverting and relocating onto bracket as shown. Reinsert clevis pin (A) and secure with lynch pin.



**Figure 4.151: Header Stand**

15. Remove clevis pin from storage position (B) in linkage and insert into hole (A) to engage float springs. Secure with hairpin.

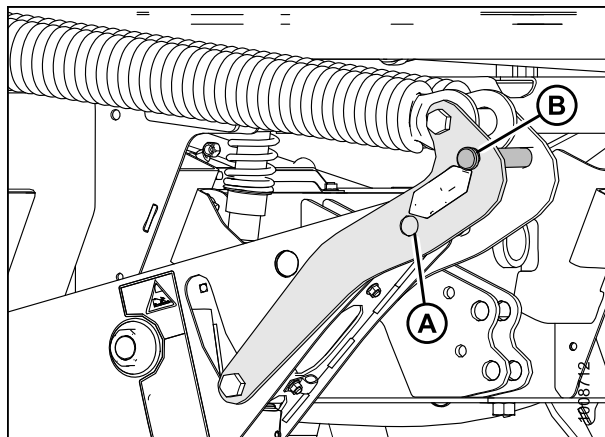

**Figure 4.152: Header Float Linkage**

16. Disengage safety prop by turning lever (A) downwards to release and lower stop until lever locks into vertical position.
17. Repeat for opposite safety prop.

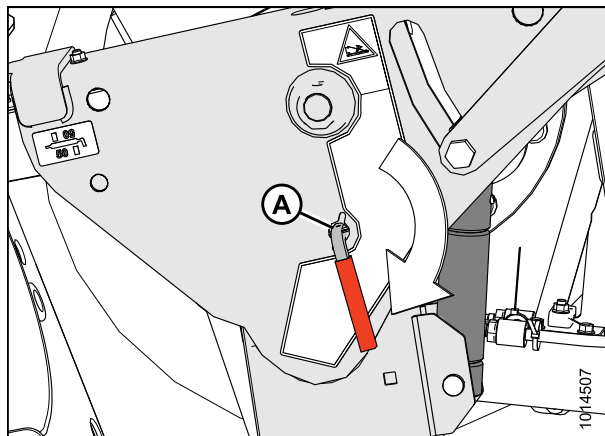

**Figure 4.153: Safety Prop**

## OPERATION

### CAUTION

Check to be sure all bystanders have cleared the area.

18. Start the engine and activate the header down switch (A) on the GSL to fully lower the header.
19. Stop engine and remove key from ignition.

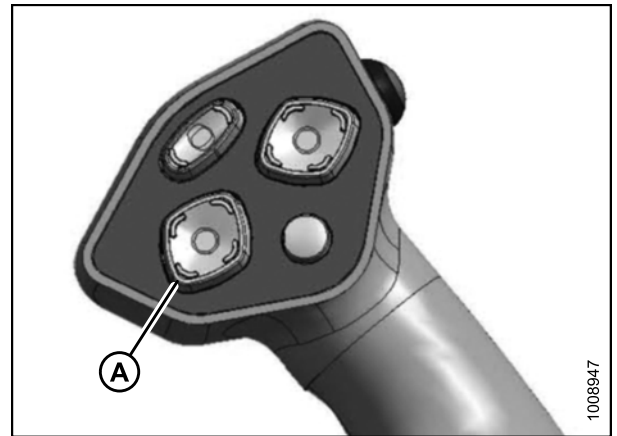

Figure 4.154: GSL

20. Connect header drive hoses (A) and electrical harness (B) to header. Refer to the auger header operator's manual.

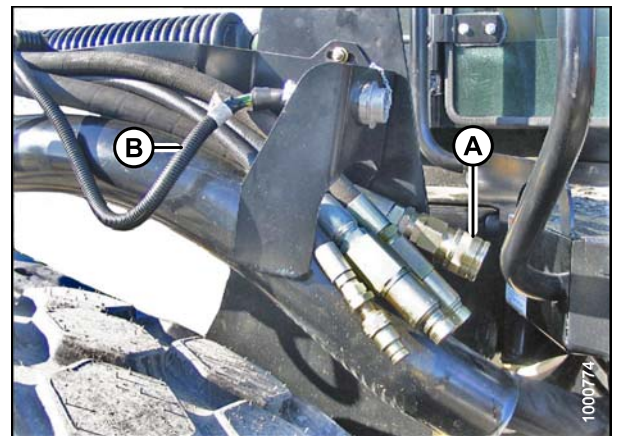

Figure 4.155: Header Drive Hoses and Harness

### *Attaching an A-Series Header: Hydraulic Center-Link without Self-Alignment*

### DANGER

To avoid bodily injury or death from unexpected startup of the machine, always stop the engine and remove the key from the ignition before leaving the operator's seat for any reason.

1. Remove hairpin (A) from clevis pin (B) and remove clevis pin from the header boots (C) on both sides of the header.

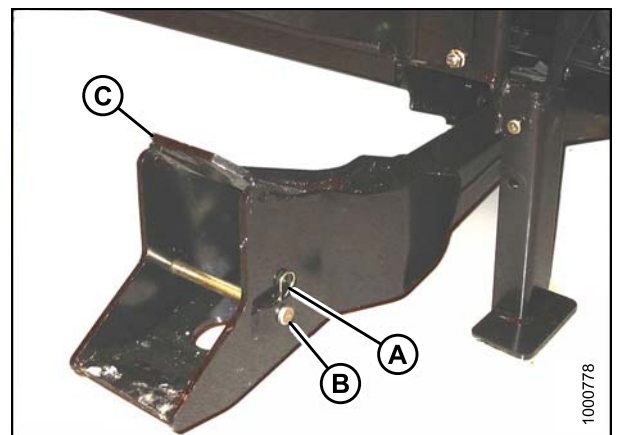

Figure 4.156: Header Boot

**CAUTION**

To prevent damage to the lift system when lowering header lift linkages without a header or weight box attached to the windrower, ensure the float engagement pin is installed in storage position (B) and NOT in engaged position (A).

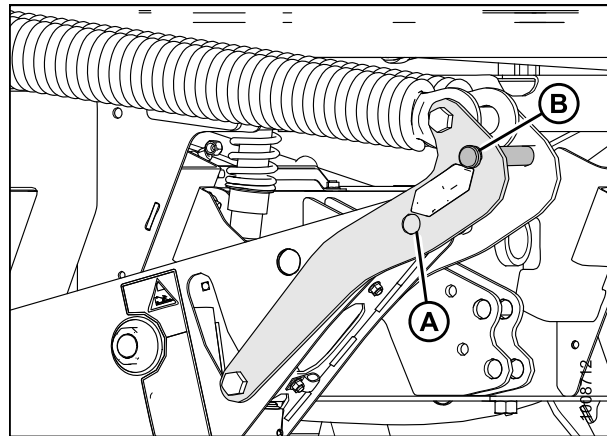

Figure 4.157: Header Float Linkage

**CAUTION**

Check to be sure all bystanders have cleared the area.

**IMPORTANT:**

Remove protective cover from exhaust stack prior to starting engine.

2. Start the engine and activate the HEADER DOWN button (A) on the ground speed lever (GSL) to fully retract header lift cylinders.

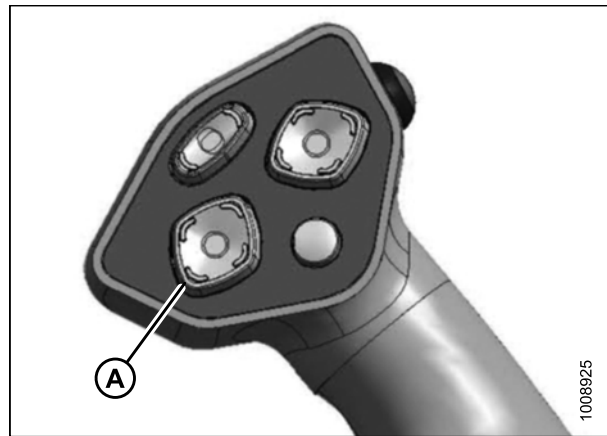

Figure 4.158: GSL

3. Relocate pin (A) in frame linkage as required to raise the center-link (B) until the hook is above the attachment pin on the header.

**IMPORTANT:**

If the center-link is too low, it may contact the header as the windrower approaches the header for hookup.

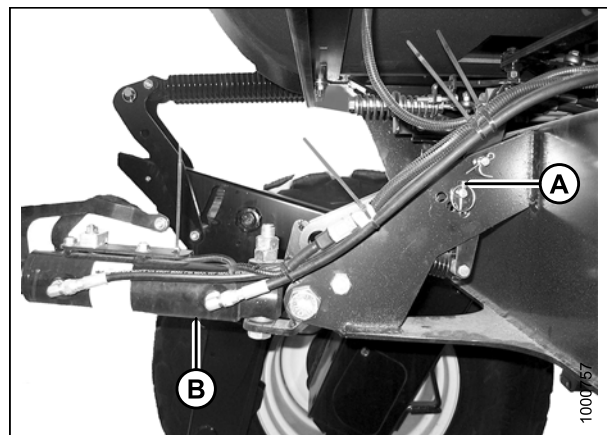

Figure 4.159: Hydraulic Center-Link without Self-Alignment Kit



## OPERATION

4. Drive the windrower slowly forward until the windrower feet (A) enter the header boots (B). Continue driving slowly forward until the feet engage the boots and the header nudges forward.

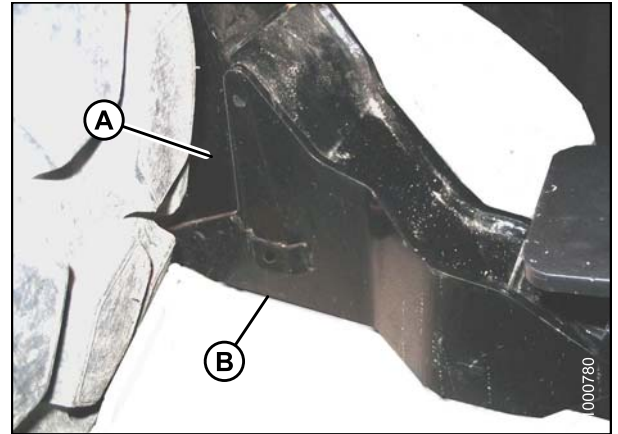

Figure 4.160: Header Boot

5. Use the following GSL functions to position the center-link hook above the header attachment pin:
  - Header tilt up (A) to retract center-link
  - Header tilt down (B) to extend center-link
6. Stop engine and remove key from ignition.

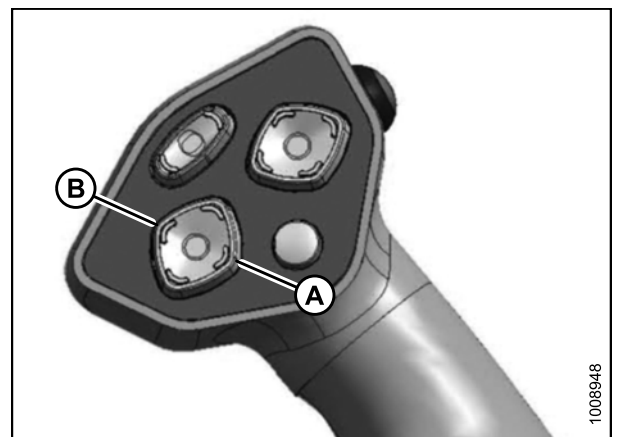

Figure 4.161: GSL

7. Push down on rod end of link cylinder (B) until hook engages and locks onto header pin.

**IMPORTANT:**

Hook release must be down to enable self-locking mechanism. If the release is open (up), manually push it down after hook engages header pin.

8. Check that center-link (A) is locked onto header by pulling upward on rod end (B) of cylinder.

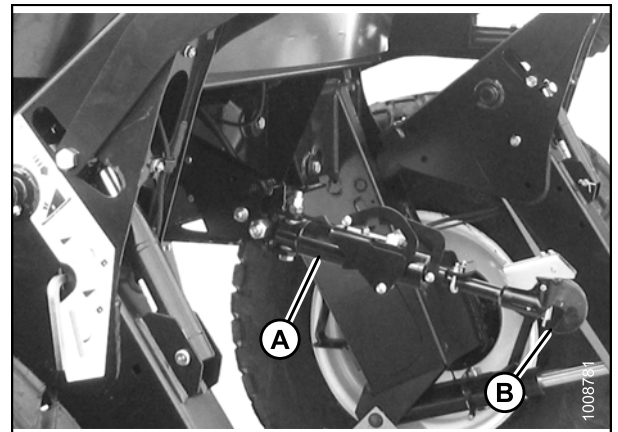

Figure 4.162: Hydraulic Center-Link

## OPERATION

### CAUTION

Check to be sure all bystanders have cleared the area.

9. Start the engine.
10. Press the header up switch (A) to raise header to maximum height.

#### NOTE:

If one end of the header does **NOT** fully raise, rephase the lift cylinders as follows:

- a. Press and hold the header up switch until both cylinders stop moving.
- b. Continue to hold the switch for 3–4 seconds. Cylinders are now phased.

#### NOTE:

It may be necessary to repeat this procedure if there is air in the system.

11. Engage safety props on both lift cylinders as follows:
  - a. Stop engine and remove key from ignition.
  - b. Pull lever (A) and rotate towards the header to release and lower safety prop (B) onto the lift cylinder.
  - c. Repeat for opposite lift cylinder.

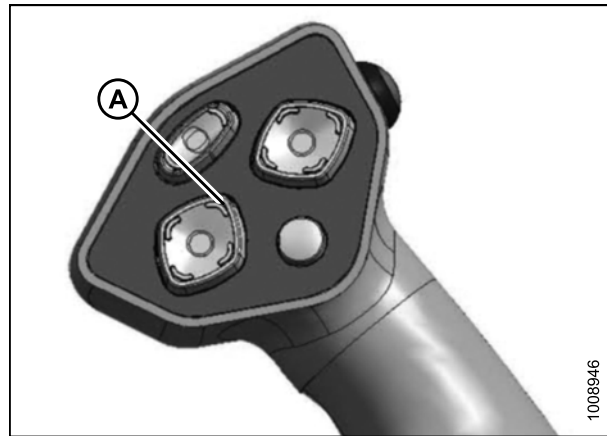

Figure 4.163: GSL

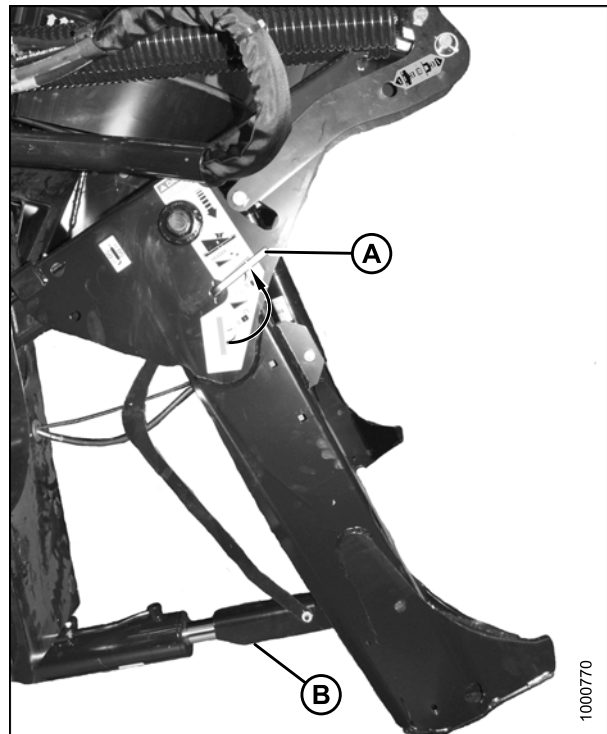

Figure 4.164: Safety Prop

## OPERATION

12. Install clevis pin (A) through boot and foot and secure with hairpin. Repeat for opposite boot.

**IMPORTANT:**

Ensure clevis pin (A) is fully inserted and hairpin is installed behind bracket.

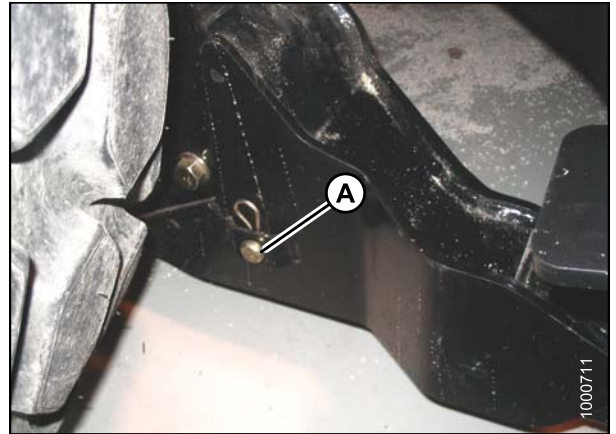

**Figure 4.165: Header Boot**

13. Remove lynch pin from clevis pin (A) in stand (B).
14. Hold stand (B) and remove pin (A).
15. Move stand (B) to storage position by inverting and relocating onto bracket as shown. Reinsert clevis pin (A) and secure with lynch pin.

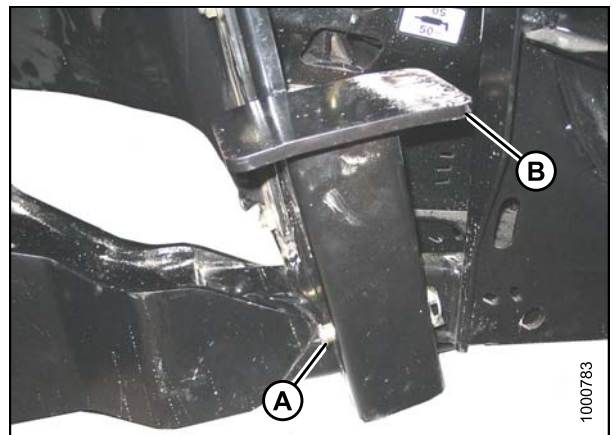

**Figure 4.166: Header Stand**

16. Remove clevis pin from storage position (B) in linkage and insert into hole (A) to engage float springs. Secure with hairpin.

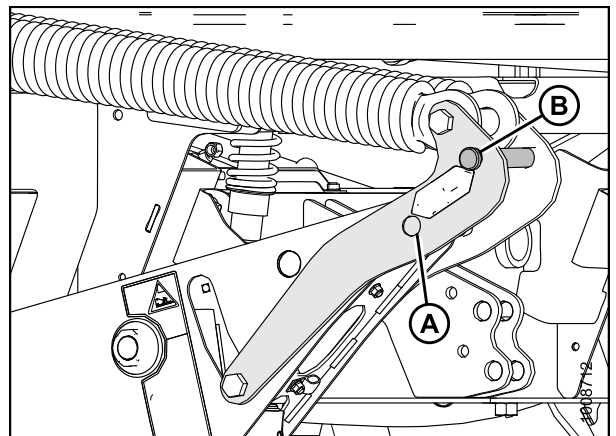

**Figure 4.167: Header Float Linkage**

## OPERATION

17. Disengage safety prop by turning lever (A) downwards to release and lower stop until lever locks into vertical position.
18. Repeat for opposite safety prop.

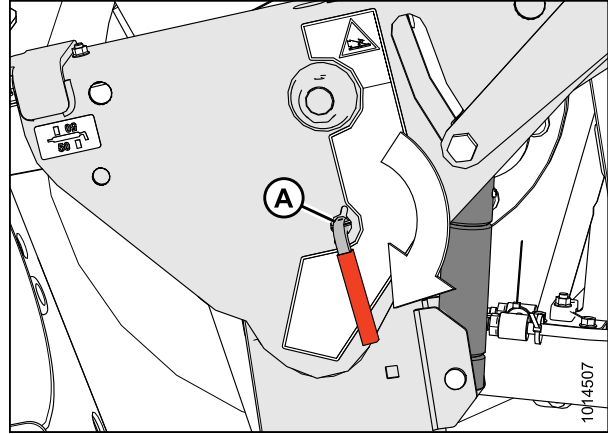

Figure 4.168: Safety Prop

### CAUTION

Check to be sure all bystanders have cleared the area.

19. Start the engine and activate the header down switch (A) on the GSL to fully lower the header.
20. Stop engine and remove key from ignition.

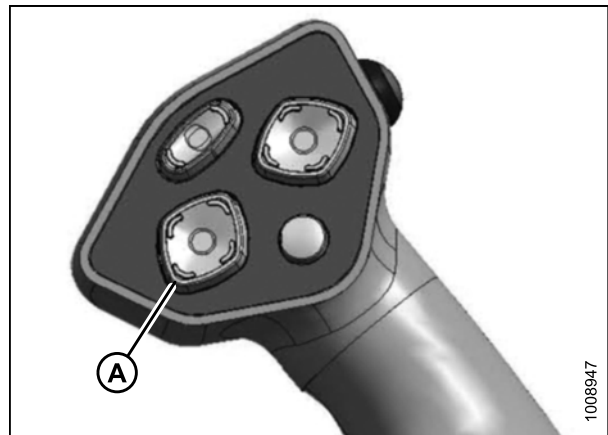

Figure 4.169: GSL

21. Connect header drive hoses (A) and electrical harness (B) to header. Refer to the auger header operator's manual.

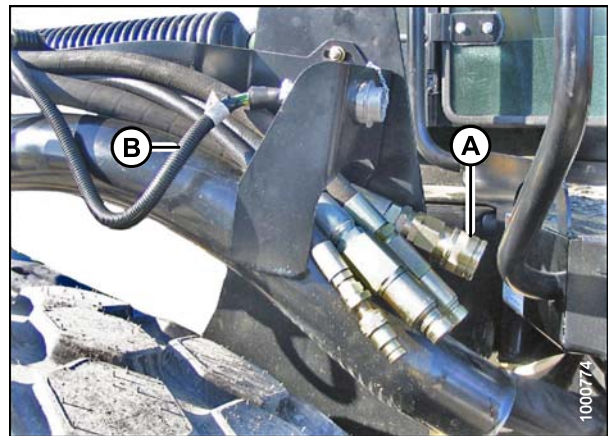

Figure 4.170: Header Drive Hoses and Harness

## 4.5.4 Detaching an A-Series Header

### *Detaching an A-Series Header: Hydraulic Center-Link*

#### **⚠ WARNING**

To avoid bodily injury or death from unexpected startup of machine, always stop engine and remove key before making adjustments to the machine.

1. Start engine and press header up button (A) on ground speed lever (GSL) to raise header to maximum height.
2. If one end of the header does **NOT** raise fully, rephase the cylinders as follows:
  - a. Press and hold the header up (A) switch until both cylinders stop moving.
  - b. Continue to hold the switch for 3–4 seconds. Cylinders are now phased.
3. Stop engine and remove key.

#### **⚠ DANGER**

To avoid bodily injury from fall of raised header, always engage safety props when working on or around raised header, and before going under header for any reason.

4. Pull lever (A) and rotate toward header to lower safety prop (B) onto cylinder. Repeat for opposite cylinder.

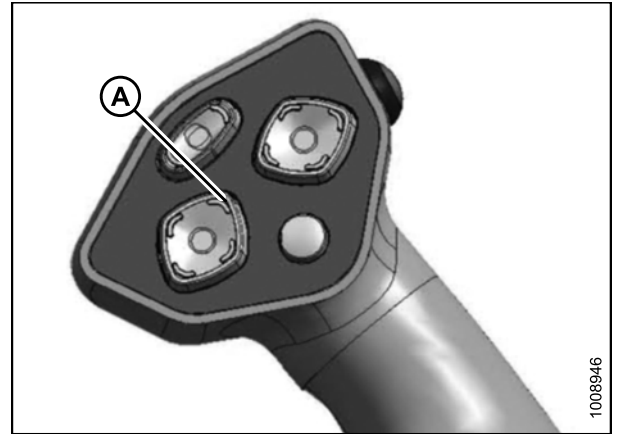

Figure 4.171: GSL

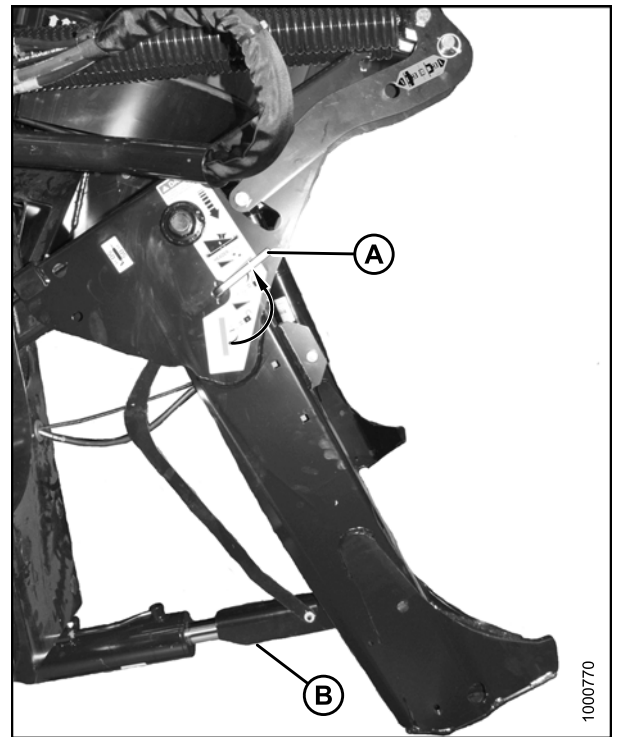

Figure 4.172: Safety Prop

## OPERATION

- Remove hairpin from the clevis pin (A) and remove clevis pin from header boots (B) on both sides.

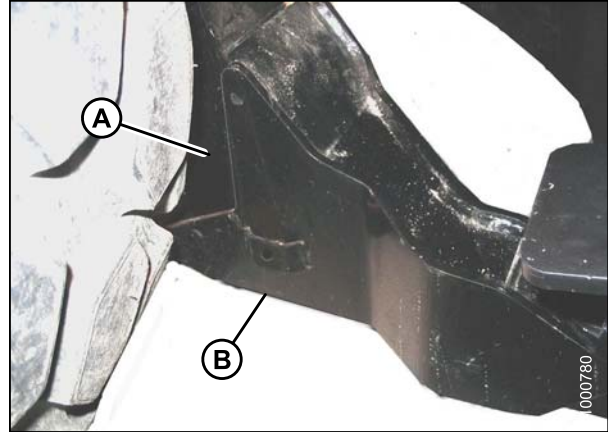

Figure 4.173: Header Boot

- Lower stand (A) by pulling clevis pin (B), inverting stand, and relocating on bracket. Reinsert pin (B) and secure with hairpin.

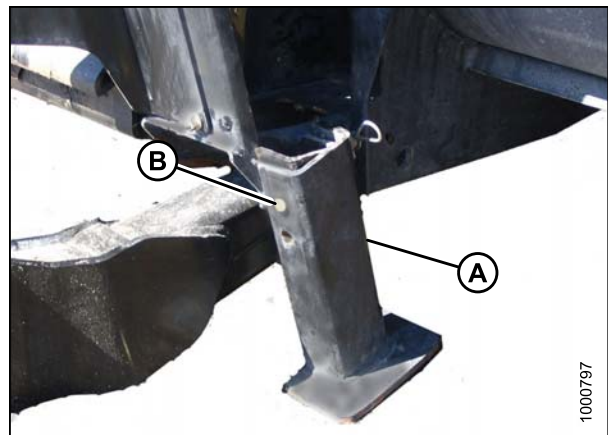

Figure 4.174: Header Stand

- Remove clevis pin from linkage (A) to disengage float springs, and insert clevis pin into storage hole (B). Secure with lynch pin. Repeat for opposite linkage.

### CAUTION

To prevent damage to the lift system when lowering header lift linkages without a header or weight box attached to the windrower, ensure the float engagement pin is installed in storage position (B) and NOT in engaged position (A).

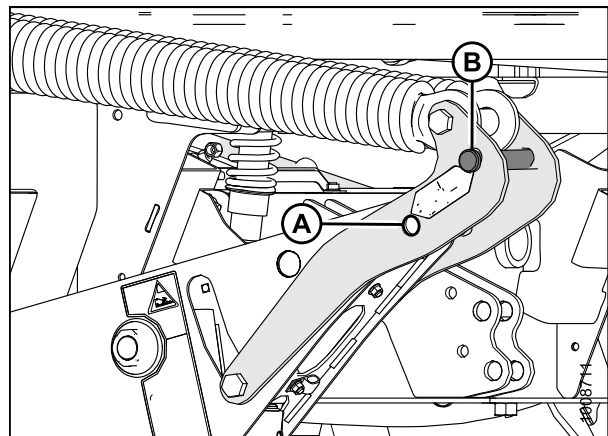

Figure 4.175: Header Float Linkage

## OPERATION

### CAUTION

Check to be sure all bystanders have cleared the area.

8. Disengage safety props by turning lever (A) away from header to raise safety prop until lever locks into vertical position. Repeat for opposite cylinder.
9. Start engine, choose a level area, and lower header to the ground.
10. Activate header tilt up (A) and header tilt down (B) cylinder switches on GSL to release load on center-link cylinder.

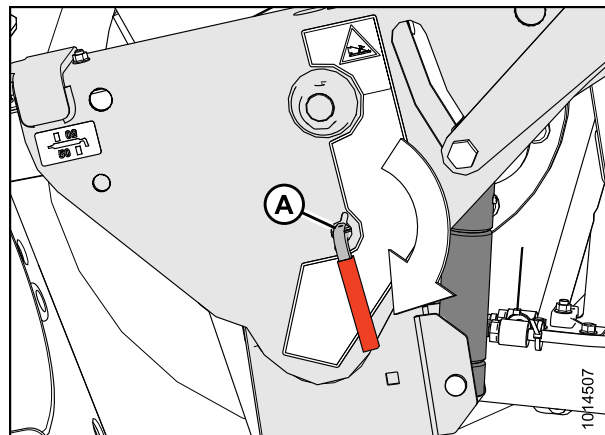

Figure 4.176: Safety Props

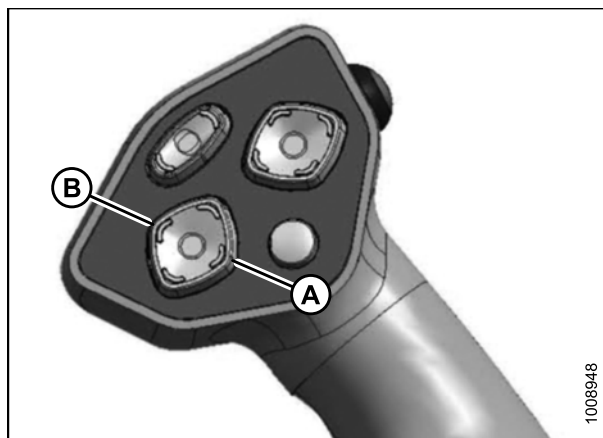

Figure 4.177: GSL

11. Stop engine and remove key from ignition.
12. Lift hook release (C) and lift hook (B) off header pin.

#### NOTE:

If optional center-link self-alignment kit is installed, lift release (C) and then operate the link lift cylinder with reel up switch on GSL to disengage the center-link from the header.

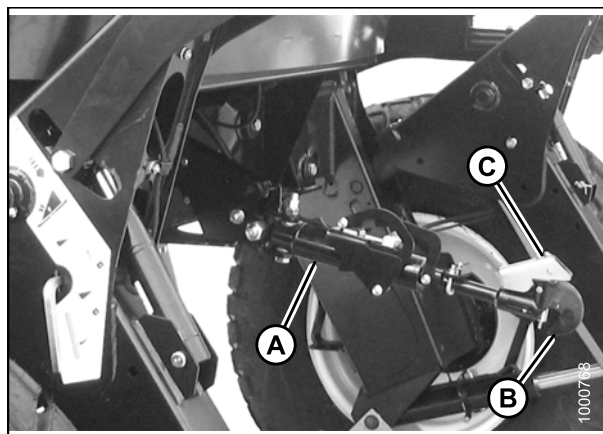

Figure 4.178: Hydraulic Center-Link

## OPERATION

13. Disconnect header drive hydraulics (A) and electrical harness (B). Refer to the auger header operator's manual.
14. Back windrower slowly away from header.

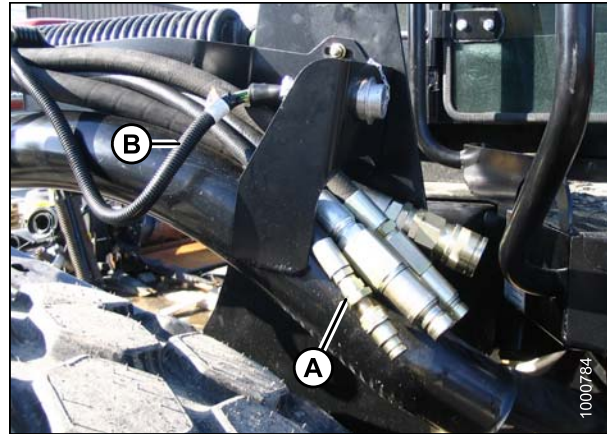

Figure 4.179: Header Drive Hydraulics

15. Reinstall clevis pin (B) into header boot (C) and secure with hairpin (A). Repeat for opposite side.

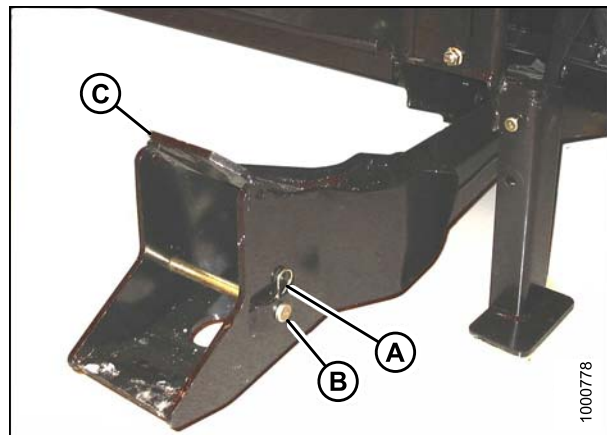

Figure 4.180: Header Boots

### 4.5.5 Attaching an R-Series Header

R-Series Rotary Disc Headers (R80 and R85) can be attached to an M155E4 Self-Propelled Windrower.

Refer to the following instructions based on the type of center-link installed on your windrower:

- [Attaching an R-Series Header: Hydraulic Center-Link with Optional Self-Alignment, page 244](#)
- [Attaching an R-Series Header: Hydraulic Center-Link without Self-Alignment, page 250](#)

*Attaching an R-Series Header: Hydraulic Center-Link with Optional Self-Alignment*

#### DANGER

To avoid bodily injury or death from unexpected startup of the machine, always stop the engine and remove the key from the ignition before leaving the operator's seat for any reason.



## OPERATION

1. Remove hairpin (B) from clevis pin (A) and remove clevis pin from the header boots (C) on both sides of the header.

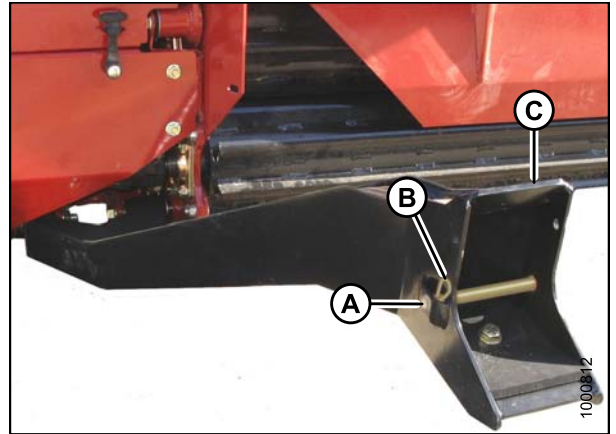

Figure 4.181: Header Boot

### CAUTION

To prevent damage to the lift system when lowering header lift linkages without a header or weight box attached to the windrower, ensure the float engagement pin is installed in storage position (B) and NOT in engaged position (A).

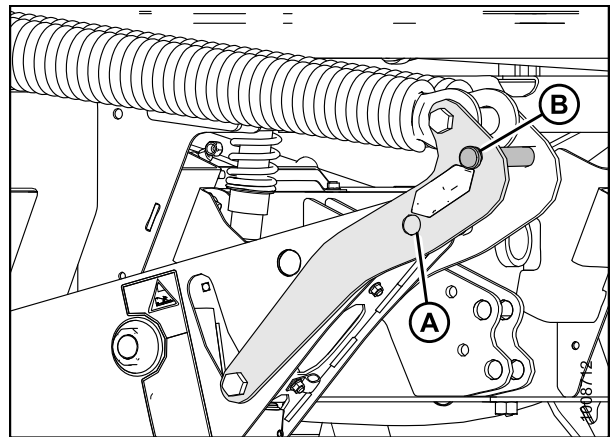

Figure 4.182: Header Float Linkage

### CAUTION

Check to be sure all bystanders have cleared the area.

#### **IMPORTANT:**

Remove protective cover from exhaust stack prior to starting engine.

2. Start the engine and activate the HEADER DOWN button (A) on the ground speed lever (GSL) to fully retract header lift cylinders.

#### **IMPORTANT:**

If the center-link is too low, it may contact the header as the windrower approaches the header for hookup.

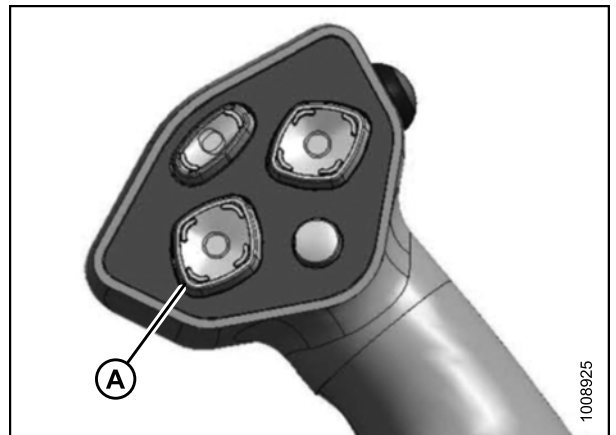

Figure 4.183: GSL

## OPERATION

3. Activate the reel up switch (A) on the GSL to raise the center-link until the hook is above the attachment pin on the header.

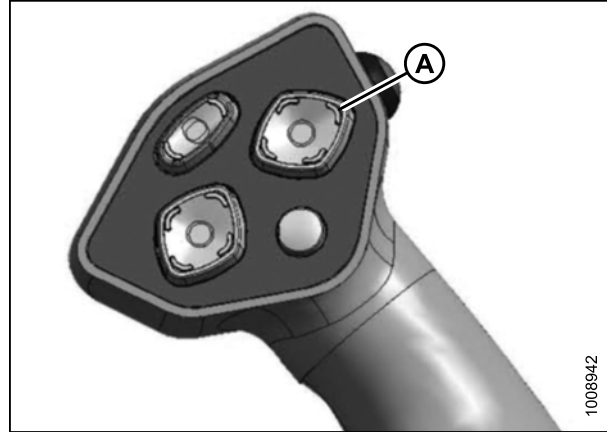

Figure 4.184: GSL

4. Drive the windrower slowly forward until the windrower feet (A) enter the header boots (B). Continue driving slowly forward until the feet engage the boots and the header nudges forward.

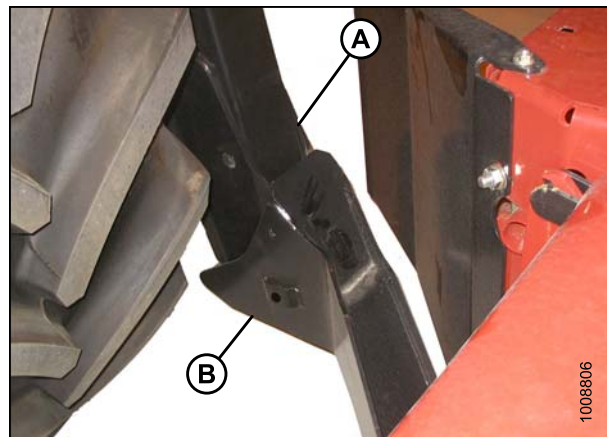

Figure 4.185: Header Boot

5. Use the following GSL functions to position the center-link hook above the header attachment pin:
  - Reel up (A) to raise the center-link
  - Reel down (B) to lower the center-link
  - Header tilt up (C) to retract the center-link
  - Header tilt down (D) to extend the center-link

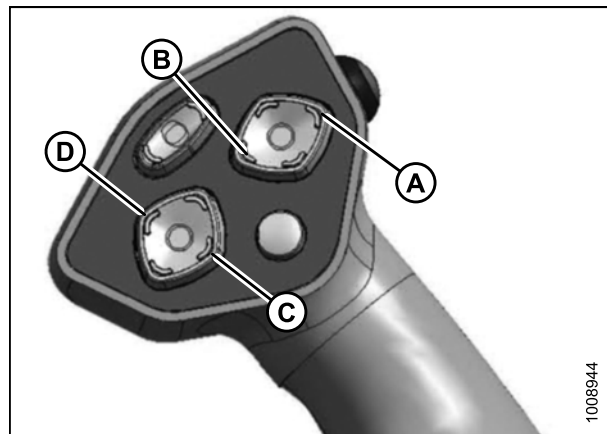

Figure 4.186: GSL

## OPERATION

- Adjust position of the center-link cylinder (A) with the reel up and reel down switches on the GSL until the hook is positioned above the header attachment pin.

### IMPORTANT:

Hook release must be down to enable self-locking mechanism. If the release is open (up), manually push it down after hook engages header pin.

- Lower center-link (A) onto the header with reel down switch until it locks into position (hook release [B] is down).
- Check that center-link is locked onto header by pressing the reel up switch on the GSL.

### CAUTION

Check to be sure all bystanders have cleared the area.

- Press the header up switch (A) to raise header to maximum height.

### NOTE:

If one end of the header does **NOT** fully raise, rephase the lift cylinders as follows:

- Press and hold the header up switch until both cylinders stop moving.
- Continue to hold the switch for 3–4 seconds. Cylinders are now phased.

### NOTE:

It may be necessary to repeat this procedure if there is air in the system.

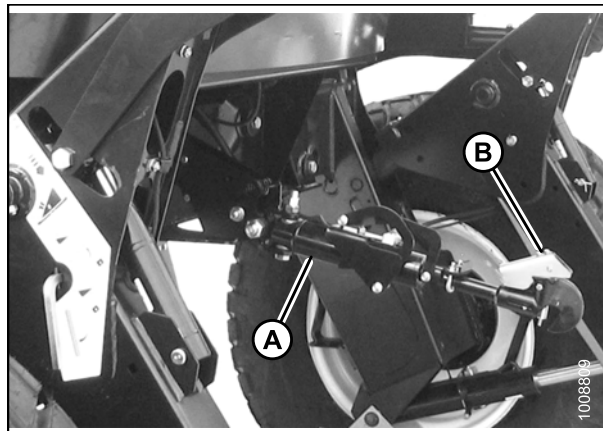

Figure 4.187: Hydraulic Center-Link



Figure 4.188: GSL

## OPERATION

10. Engage safety props on both lift cylinders as follows:
  - a. Stop engine and remove key from ignition.
  - b. Pull lever (A) and rotate towards the header to release and lower safety prop (B) onto the lift cylinder.
  - c. Repeat for opposite lift cylinder.

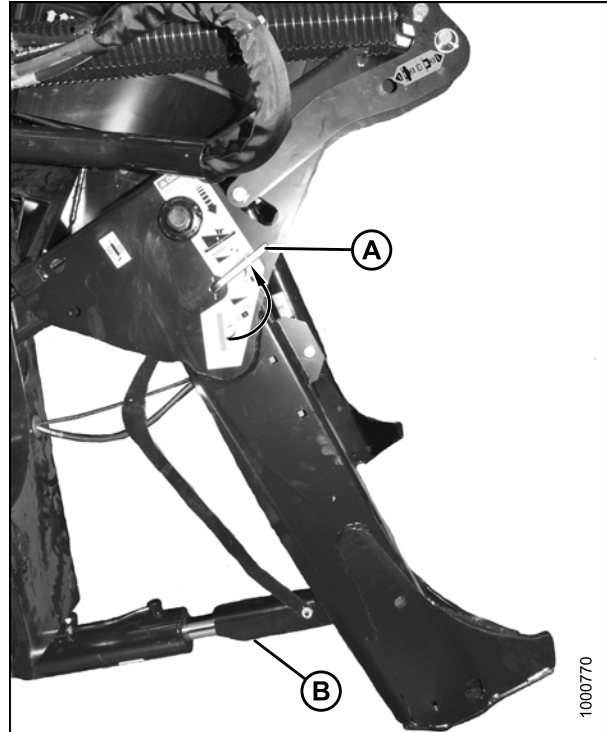

Figure 4.189: Safety Prop

11. Install clevis pin (A) through boot and foot and secure with hairpin (B). Repeat for opposite side.

**IMPORTANT:**

Ensure clevis pin (A) is fully inserted and hairpin is installed behind bracket.

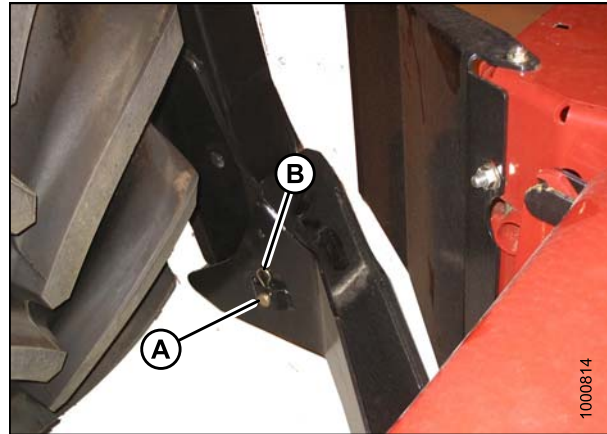

Figure 4.190: Header Boot

## OPERATION

12. Remove clevis pin from storage position (B) in linkage and insert into hole (A) to engage float springs. Secure with hairpin.

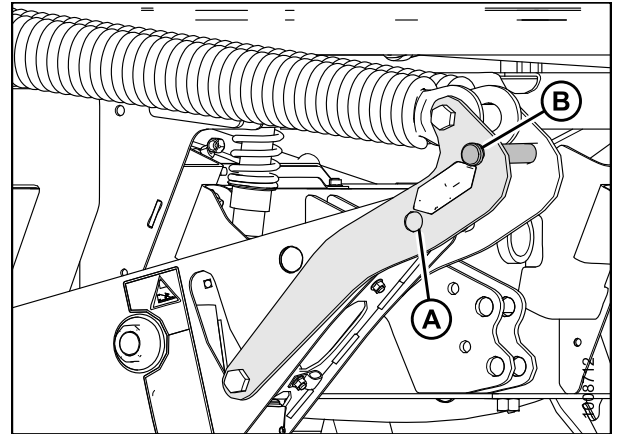

Figure 4.191: Header Float Linkage

13. Disengage safety prop by turning lever (A) downwards to release and lower stop until lever locks into vertical position.
14. Repeat for opposite safety prop.

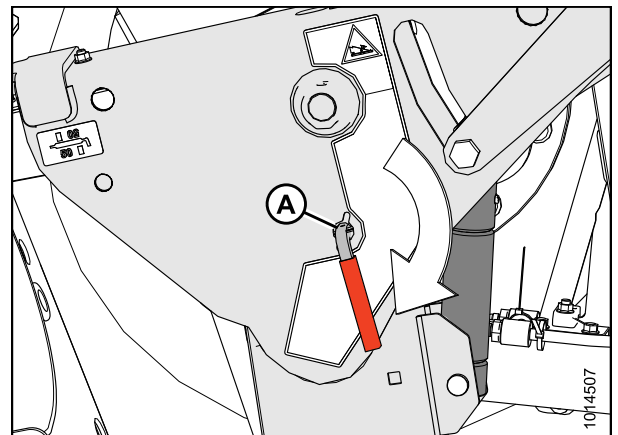

Figure 4.192: Safety Prop

### CAUTION

Check to be sure all bystanders have cleared the area.

15. Start the engine and activate the header down switch (A) on the GSL to fully lower the header.
16. Stop engine and remove key from ignition.

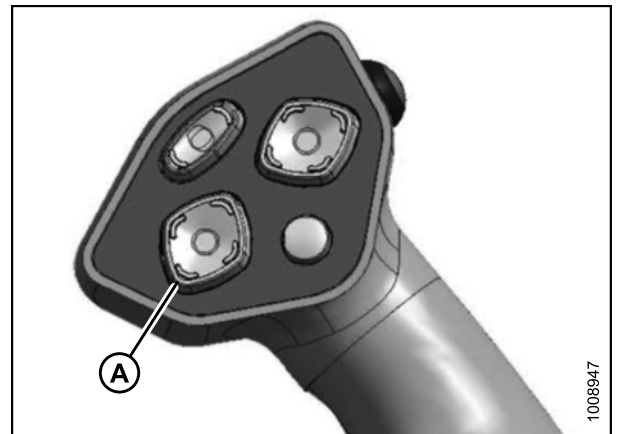

Figure 4.193: GSL

## OPERATION

17. Connect header drive hoses (A) and electrical harness (B) to header. Refer to the rotary disc header operator's manual.

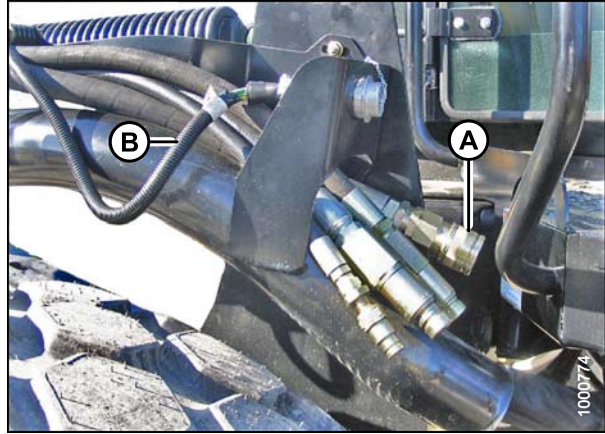

Figure 4.194: Header Drive Hoses and Harness

### *Attaching an R-Series Header: Hydraulic Center-Link without Self-Alignment*

#### **⚠ DANGER**

To avoid bodily injury or death from unexpected startup of the machine, always stop the engine and remove the key from the ignition before leaving the operator's seat for any reason.

1. Remove hairpin (B) from clevis pin (A) and remove clevis pin from the header boots (C) on both sides of the header.

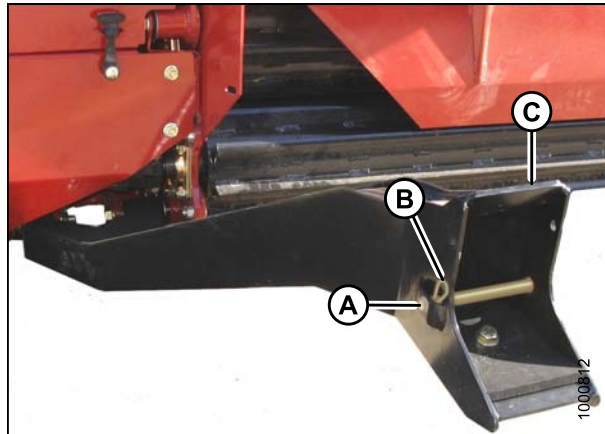

Figure 4.195: Header Boot

#### **⚠ CAUTION**

To prevent damage to the lift system when lowering header lift linkages without a header or weight box attached to the windrower, ensure the float engagement pin is installed in storage position (B) and NOT in engaged position (A).

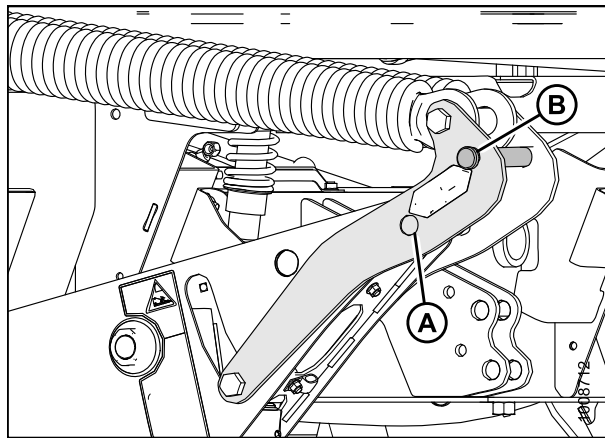

Figure 4.196: Header Float Linkage

**⚠ CAUTION**

Check to be sure all bystanders have cleared the area.

**IMPORTANT:**

Remove protective cover from exhaust stack prior to starting engine.

2. Start the engine and activate the HEADER DOWN button (A) on the ground speed lever (GSL) to fully retract header lift cylinders.

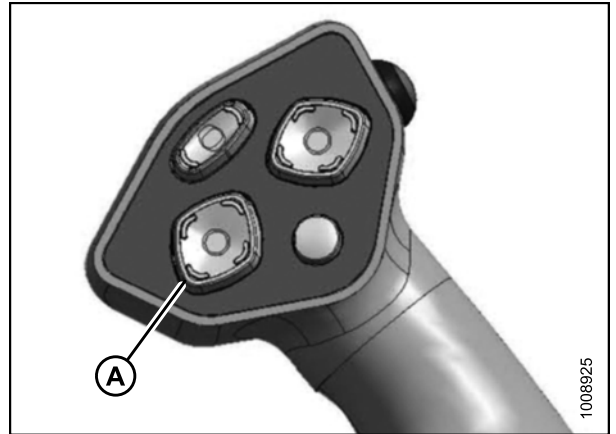

Figure 4.197: GSL

3. Relocate pin (A) in frame linkage as required to raise the center-link (B) until the hook is above the attachment pin on the header.

**IMPORTANT:**

If the center-link is too low, it may contact the header as the windrower approaches the header for hookup.

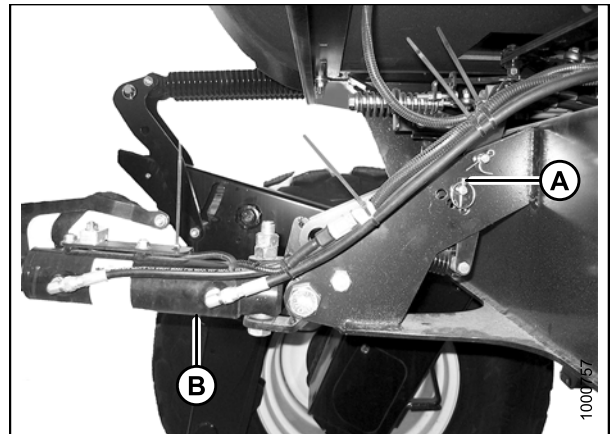

Figure 4.198: Hydraulic Center-Link without Self-Alignment Kit

4. Drive the windrower slowly forward until the windrower feet (A) enter the header boots (B). Continue driving slowly forward until the feet engage the boots and the header nudges forward.

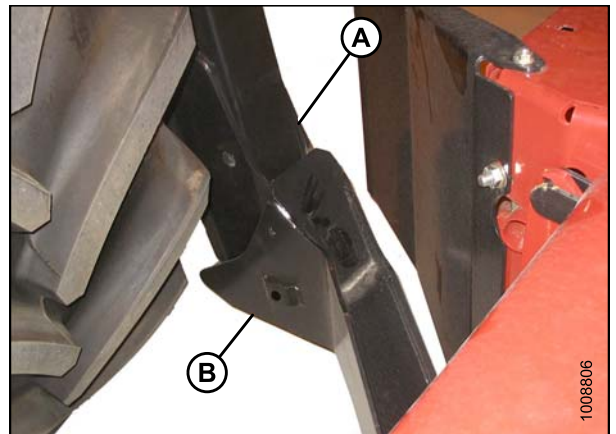

Figure 4.199: Header Boot

## OPERATION

5. Use the following GSL functions to position the center-link hook above the header attachment pin:
  - Header tilt up (A) to retract the center-link
  - Header tilt down (B) to extend the center-link
6. Stop engine and remove key from ignition.

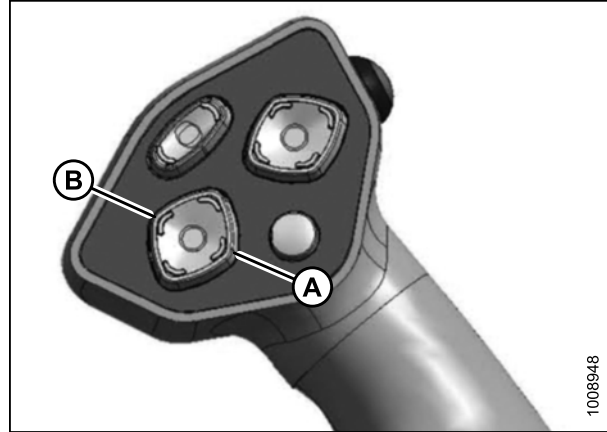

Figure 4.200: GSL

7. Push down on rod end of link cylinder (B) until hook engages and locks onto header pin.

### IMPORTANT:

Hook release must be down to enable self-locking mechanism. If the release is open (up), manually push it down after hook engages header pin.

8. Check that center-link (A) is locked onto header by pulling upward on rod end (B) of cylinder.

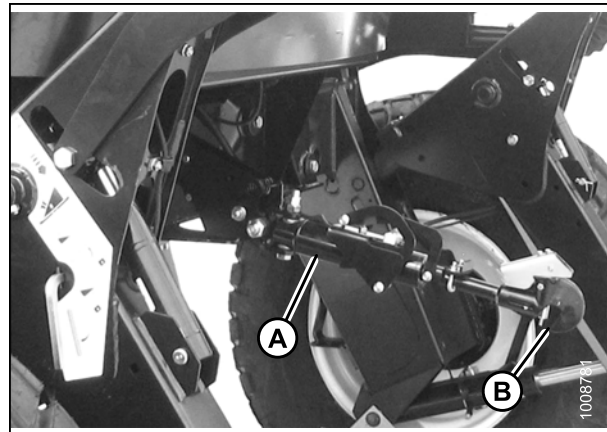

Figure 4.201: Hydraulic Center-Link

## CAUTION

Check to be sure all bystanders have cleared the area.

9. Start the engine.
10. Press the header up switch (A) to raise header to maximum height.

### NOTE:

If one end of the header does **NOT** fully raise, rephase the lift cylinders as follows:

- a. Press and hold the header up switch until both cylinders stop moving.
- b. Continue to hold the switch for 3–4 seconds. Cylinders are now phased.

### NOTE:

It may be necessary to repeat this procedure if there is air in the system.



Figure 4.202: GSL



## OPERATION

11. Engage safety props on both lift cylinders as follows:
  - a. Stop engine and remove key from ignition.
  - b. Pull lever (A) and rotate towards the header to release and lower safety prop (B) onto the lift cylinder.
  - c. Repeat for opposite lift cylinder.

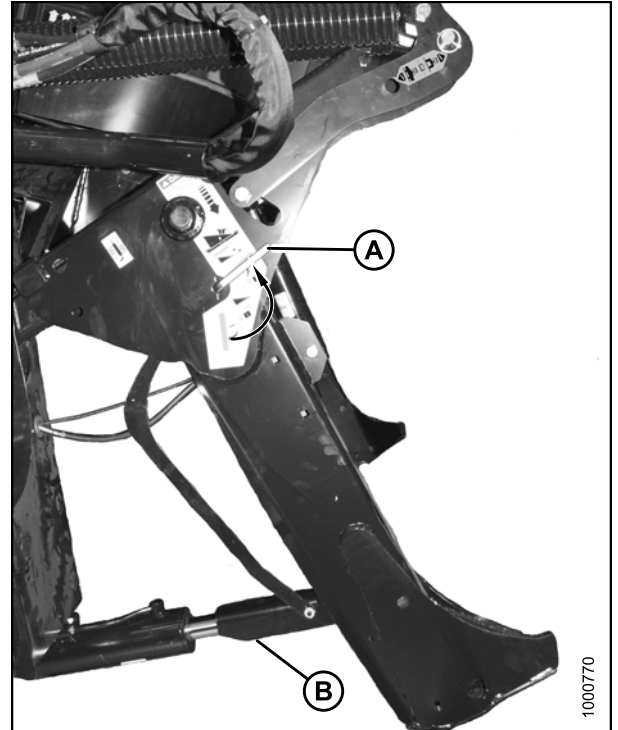

Figure 4.203: Safety Prop

12. Install clevis pin (A) through boot and foot and secure with hairpin (B). Repeat for opposite side.

**IMPORTANT:**

Ensure clevis pin (A) is fully inserted and hairpin is installed behind bracket.

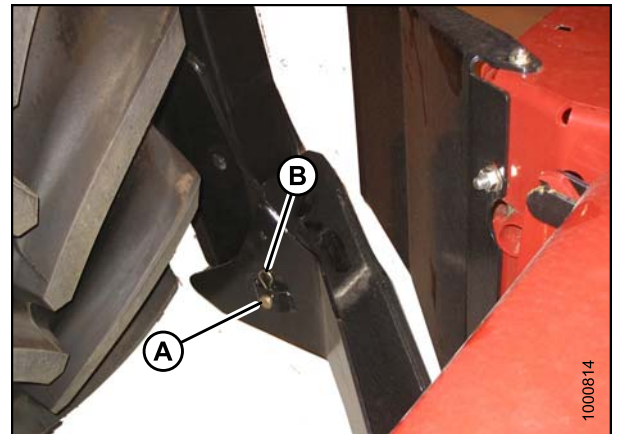

Figure 4.204: Header Boot

## OPERATION

13. Remove clevis pin from storage position (B) in linkage and insert into hole (A) to engage float springs. Secure with hairpin.

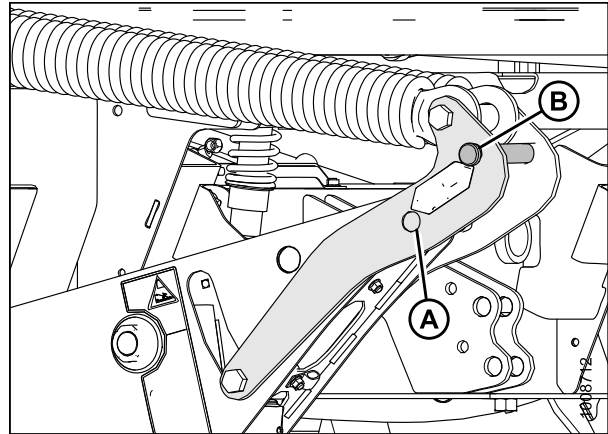

Figure 4.205: Header Float Linkage

14. Disengage safety prop by turning lever (A) downwards to release and lower stop until lever locks into vertical position.
15. Repeat for opposite safety prop.

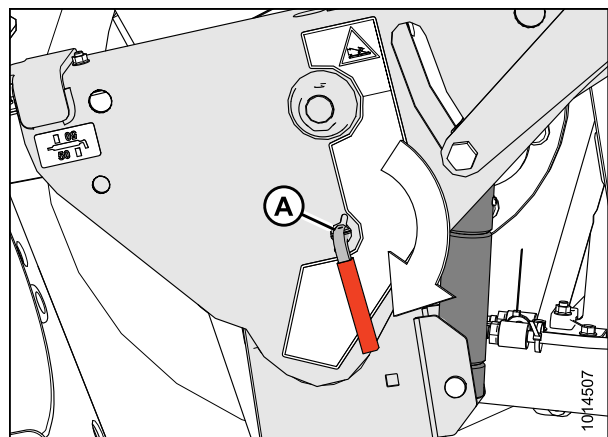

Figure 4.206: Safety Prop

### CAUTION

Check to be sure all bystanders have cleared the area.

16. Start the engine and activate the header down switch (A) on the GSL to fully lower the header.
17. Stop engine and remove key from ignition.

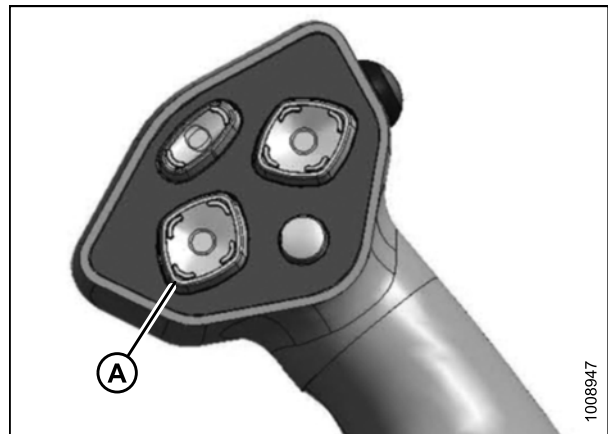

Figure 4.207: GSL

## OPERATION

18. Connect header drive hoses (A) and electrical harness (B) to header. Refer to the rotary disc header operator's manual.

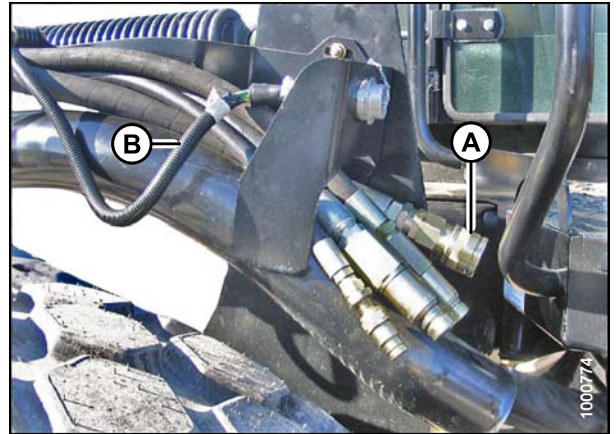

Figure 4.208: Header Drive Hoses and Harness

### 4.5.6 Detaching an R-Series Header

*Detaching an R-Series Header: Hydraulic Center-Link*

#### **DANGER**

To avoid bodily injury or death from unexpected startup of the machine, always stop the engine and remove the key from the ignition before leaving the operator's seat for any reason.

1. Start engine and press header up (A) switch to raise header to maximum height.
2. Rephase cylinders if one end of the header does not raise fully. If rephasing is required, proceed as follows:
  - a. Press and hold the header up (A) switch until both cylinders stop moving.
  - b. Continue to hold the switch for 3–4 seconds. Cylinders are now phased.

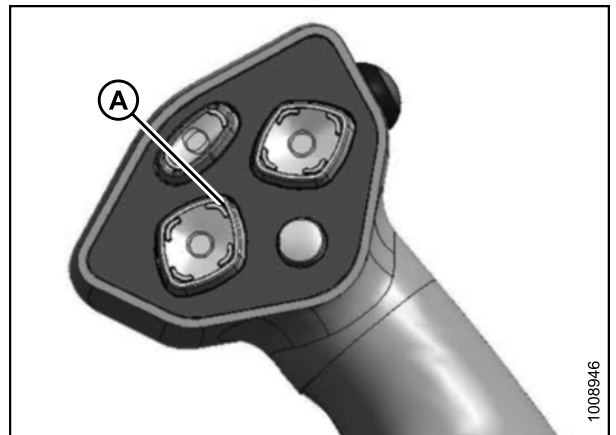

Figure 4.209: Ground Speed Lever (GSL)

## OPERATION

3. Stop engine and remove key from ignition.
4. Pull lever (A) and rotate toward header to lower safety prop (B) onto cylinder. Repeat for opposite cylinder.

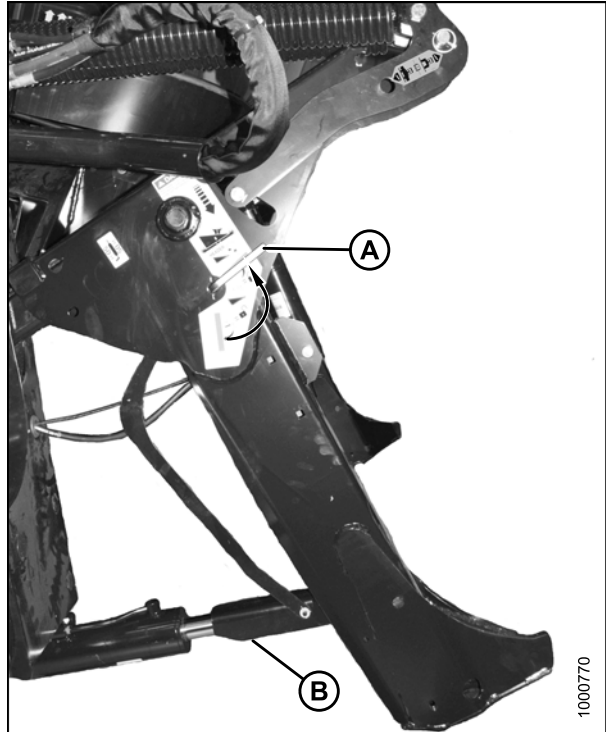

Figure 4.210: Safety Prop

5. Remove hairpin from clevis pin (A) and remove clevis pin from header boot (B) on both sides of header.

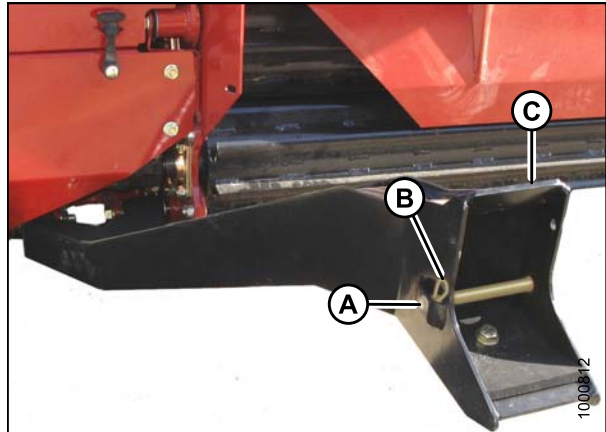

Figure 4.211: Header Boots

## OPERATION

6. Remove clevis pin from location (A) to disengage float springs and insert into storage hole (B). Secure with hairpin.

### CAUTION

To prevent damage to the lift system when lowering header lift linkages without a header or weight box attached to the windrower, ensure the float engagement pin is installed in storage position (B) and NOT in engaged position (A).

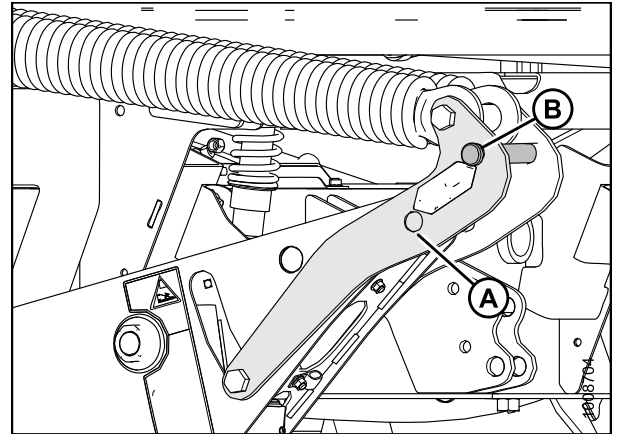

Figure 4.212: Header Float Linkage

### CAUTION

Check to be sure all bystanders have cleared the area.

7. Disengage safety props by turning lever (A) away from header to raise safety prop until lever locks into vertical position. Repeat for opposite cylinder.
8. Start engine, choose a level area, and lower header to the ground.

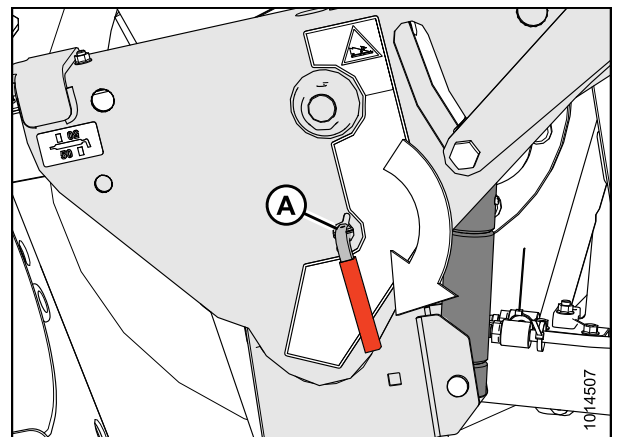

Figure 4.213: Safety Props

9. Activate header tilt up (A) and header tilt down (B) cylinder switches on GSL to release load on center-link cylinder.

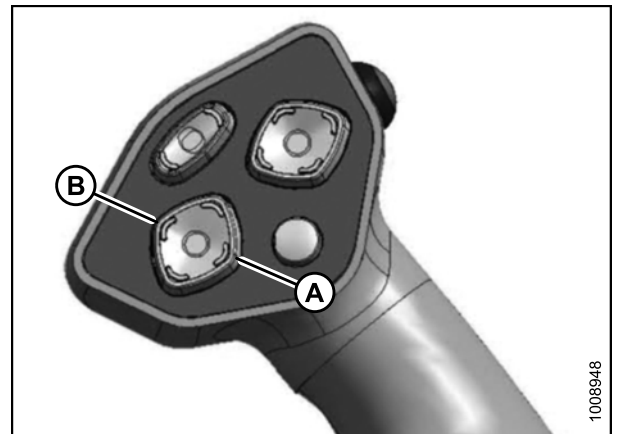

Figure 4.214: GSL

## OPERATION

10. Stop engine and remove key from ignition.
11. Lift hook release (C) and lift hook (B) off header pin.

**NOTE:**

If optional center-link lift cylinder is installed, lift release (C) and then operate the link lift cylinder from the cab to disengage the center-link from the header.

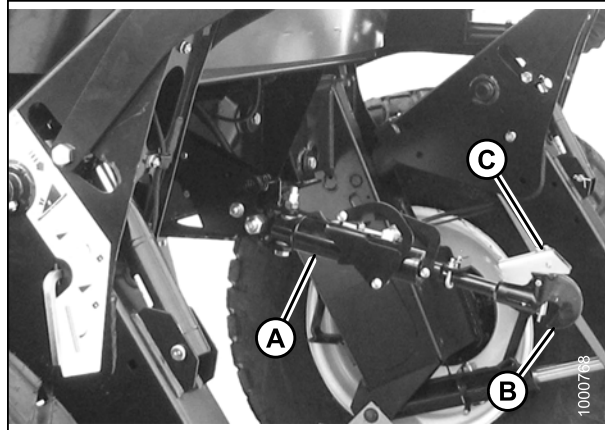

**Figure 4.215: Hydraulic Center-Link**

12. Disconnect header drive hydraulics (A) and electrical harness (B). Refer to the header operator's manual.
13. Back windrower slowly away from header.

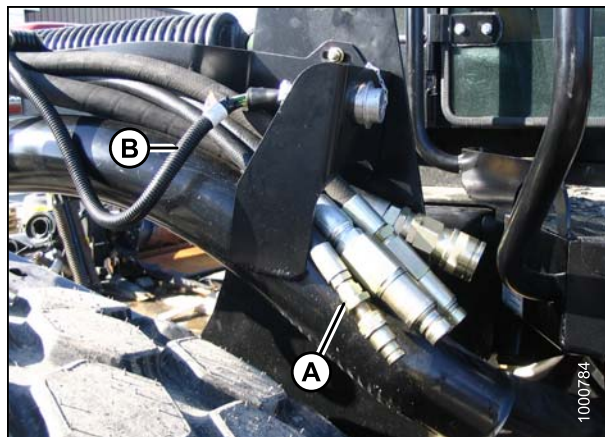

**Figure 4.216: Header Drive Hydraulics**

14. Reinstall clevis pin (A) through boot (C) and secure with hairpin (B). Repeat for opposite side.

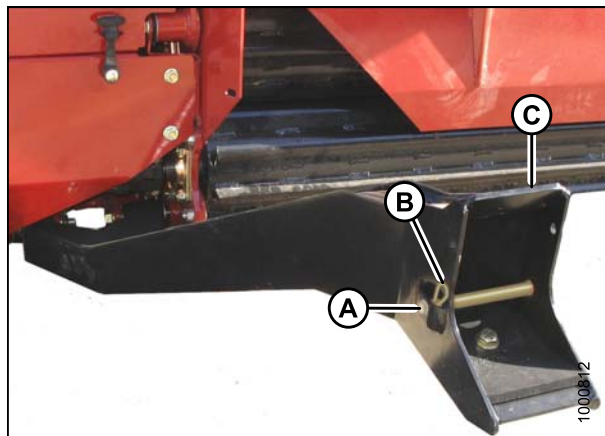

**Figure 4.217: Header Boot**

## 4.6 Operating with a D-Series Header

The M155E4 Self-Propelled Windrower is factory-equipped to run a D-Series Draper Header.

If installing a HC10 Hay Conditioner, Reverser kit #B4656 is recommended. If necessary, obtain the recommended kit from your MacDon Dealer and install it in accordance with the instructions supplied with the kit.

Refer to the procedures below for the center-link installed on your windrower:

- [Attaching a D-Series Header: Hydraulic Center-Link with Optional Self-Alignment, page 215](#)
- [Attaching a D-Series Header: Hydraulic Center-Link without Self-Alignment, page 220](#)

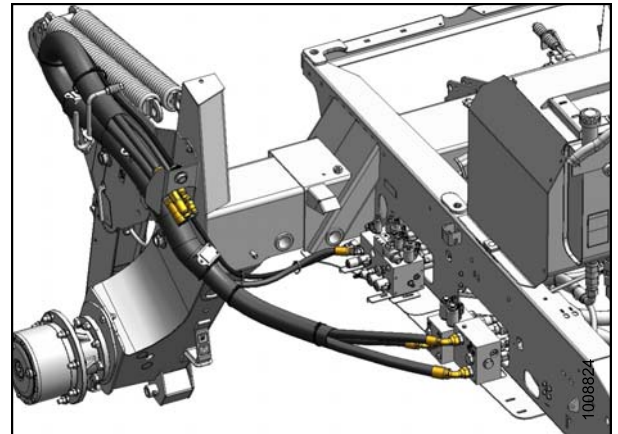

Figure 4.218: Draper Header Hydraulics

### 4.6.1 Configuring Hydraulics

The windrower must be fitted with a draper drive basic kit to operate D-Series draper headers.

Windrowers equipped with D-Series hydraulics have four header drive hoses on the left cab-forward side.

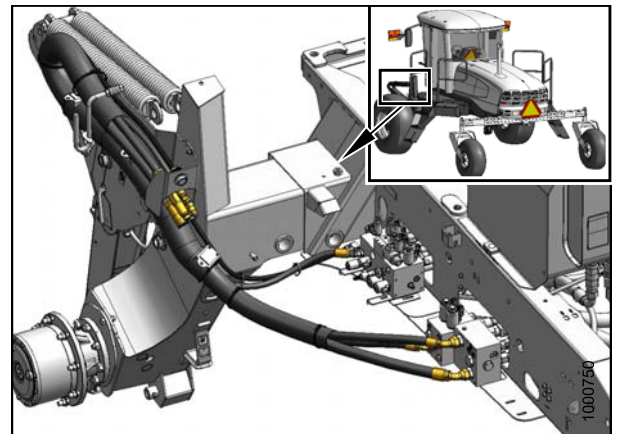

Figure 4.219: Draper Header Drive Hydraulics

There are also up to five reel drive hoses on the right cab-forward side.

If necessary, obtain the following kit from your MacDon Dealer.

- Base Kit MD #B5577 (Installation instruction is supplied with the kit.)

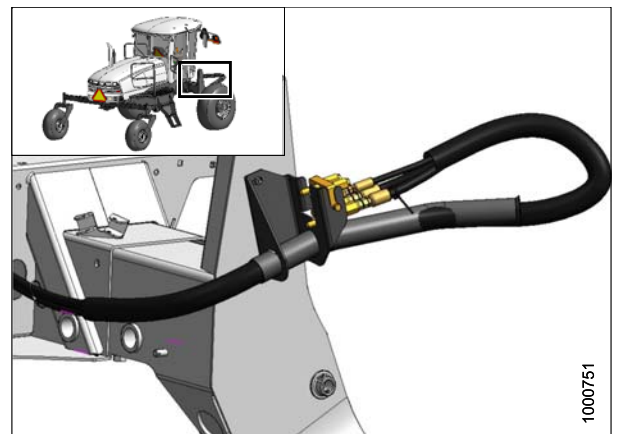

Figure 4.220: Draper Header Reel Hydraulics

## 4.6.2 Header Position

Refer to [4.4 Operating with a Header, page 194](#) for procedures for controlling header height, header tilt, and float.

## 4.6.3 Adjusting the Reel Fore-Aft Position

The reel fore-aft position can be hydraulically adjusted with the optional reel position system and is controlled with multi-function switches on the ground speed lever (GSL).

Press and hold the switch for the desired FORWARD (A) or AFT (B) movement of the reel.

### NOTE:

The switches also control adjustments to the optional double windrow attachment (DWA) conveyor and can be activated when programming the cab display module (CDM).



Figure 4.221: Ground Speed Lever (GSL)

## 4.6.4 Adjusting the Reel Height

Press and hold the switch for the desired movement of the reel REEL UP (A) or REEL DOWN (B).

### IMPORTANT:

Under certain conditions, with reel raised to full height, the reel tines may contact the cab roof. Exercise care to avoid damage to the machine.

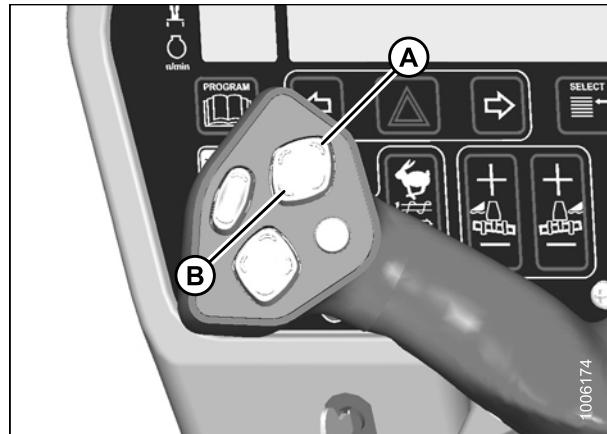

Figure 4.222: Ground Speed Lever (GSL)

## 4.6.5 Reel Speed

The reel speed is controlled with switches on the ground speed lever (GSL) in the cab. On D-Series draper headers, reel speed can be set relative to the ground speed of the windrower using the header index feature or can run independently. Refer to your header's operator manual for specific windrowing guidelines and recommended speeds.

### *Setting Reel to Ground Speed*

Setting the speed of the reel relative to ground speed (using the header index function) allows you to run the engine at lower rpm while maintaining the desired ground and reel speed. Reducing engine speed saves fuel and reduces noise in the cab.





## OPERATION

- a. Set HEADER INDEX switch (B) to **ON**.
- b. Press the DISPLAY SELECTOR button (E) on the GSL to display **##.## ##.# REEL IND**<sup>17</sup> or press FAST (C) or SLOW (D) switch.
  - The displayed value (##.##) = reel speed (rpm or mph or km/h<sup>16</sup>)
  - The displayed value (##.#) = reel index value
- c. Press FAST (C) or SLOW (D) until the desired reel index is achieved.

### NOTE:

The reel will continue operating at the minimum reel speed setting when the ground speed drops below the set value. The cab display module (CDM) display (A) will flash **##.## MIN REEL (RPM or MPH or KPH)** prompting you to change the minimum set-point or increase your ground speed if the total of the ground speed, plus the index value is **LESS THAN** the minimum reel speed set-point.

### Setting the Reel Only Speed

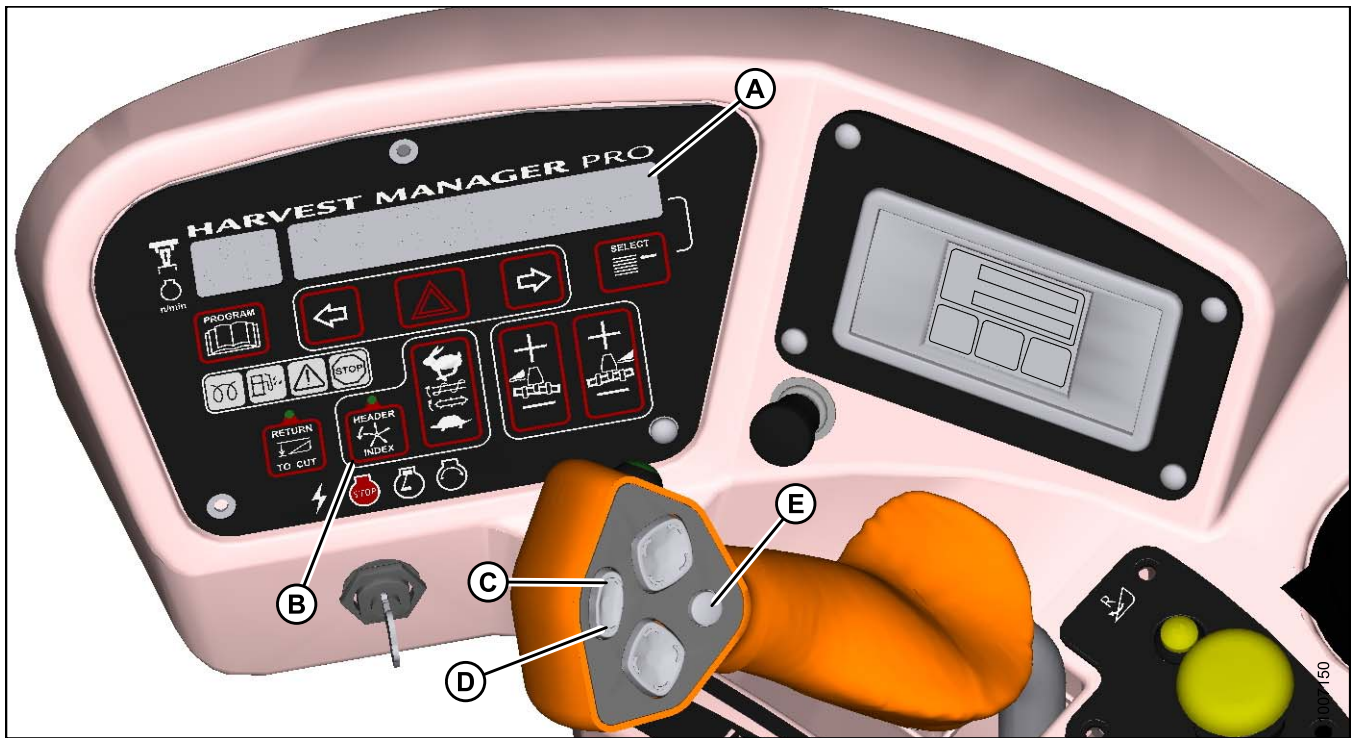

Figure 4.224: Operator Console

A - Display  
D - Reel Slow

B - Header Index  
E - Display Selector

C - Reel Fast

### CAUTION

Check to be sure all bystanders have cleared the area.

Set the speed of the reel independently of ground speed as follows while operating the windrower:

17. REEL IND will only be displayed when operating at a ground speed faster than minimum reel speed plus header index value.

## OPERATION

### NOTE:

This procedure is similar to changing the draper speed using the draper speed control switch while in motion. Refer to [Setting Draper Speed Independent of Ground Speed, page 266](#). These changes become the new set-points.

1. Set HEADER INDEX (B) to **OFF**.
2. Press REEL FAST (C) or REEL SLOW (D) on the ground speed lever (GSL) until display (A) shows **##.## REEL MPH** with desired reel speed.

The displayed value (##.##) = reel speed (rpm or mph or km/h<sup>18</sup>)

### 4.6.6 Draper Speed

Draper speed affects the orientation of stalks in the windrow. For more information, refer to your header operator's manual for guidelines.

The draper speed can be set to run independently, or relative to the ground speed of the windrower with the header index function.

#### *Setting Draper to Ground Speed*

Setting the speed of the draper relative to ground speed (using the header index function) allows you to run the engine at lower rpm while maintaining the desired ground and draper speed. Reducing engine speed saves fuel and reduces noise in the cab.

Setting draper to ground speed requires setting both the minimum draper speed and the draper index.

---

18. Depending on cab display module (CDM) programming.

## OPERATION

### Setting Draper Minimum Speed

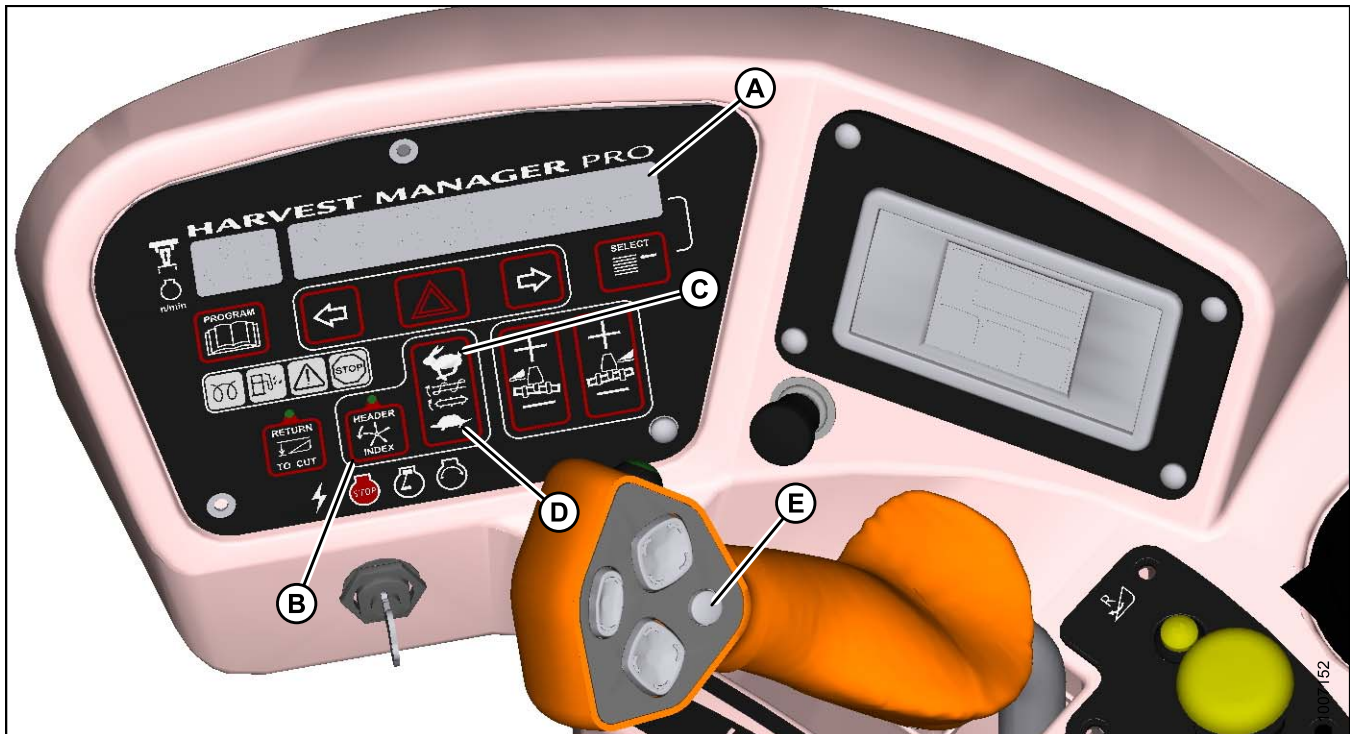

Figure 4.225: Operator Console

A - Display  
D - Draper Slow

B - Header Index  
E - Display Selector

C - Draper Fast

### CAUTION

Check to be sure all bystanders have cleared the area.

Set draper minimum speed as follows:

#### IMPORTANT:

Set the minimum draper speed while stationary with the ground speed lever (GSL) in the N-DETENT position.

1. Engage header.
2. Set HEADER INDEX (B) switch to **ON**.
3. Press DISPLAY SELECTOR button (E) until display (A) shows **### DRAPER MIN**.  
The displayed value (###) = draper speed (mph or km/h<sup>19</sup>).
4. Use the FAST (C) and SLOW (D) buttons to set the desired minimum draper speed.

19. Depending on cab display module (CDM) programming.

Setting Draper Index

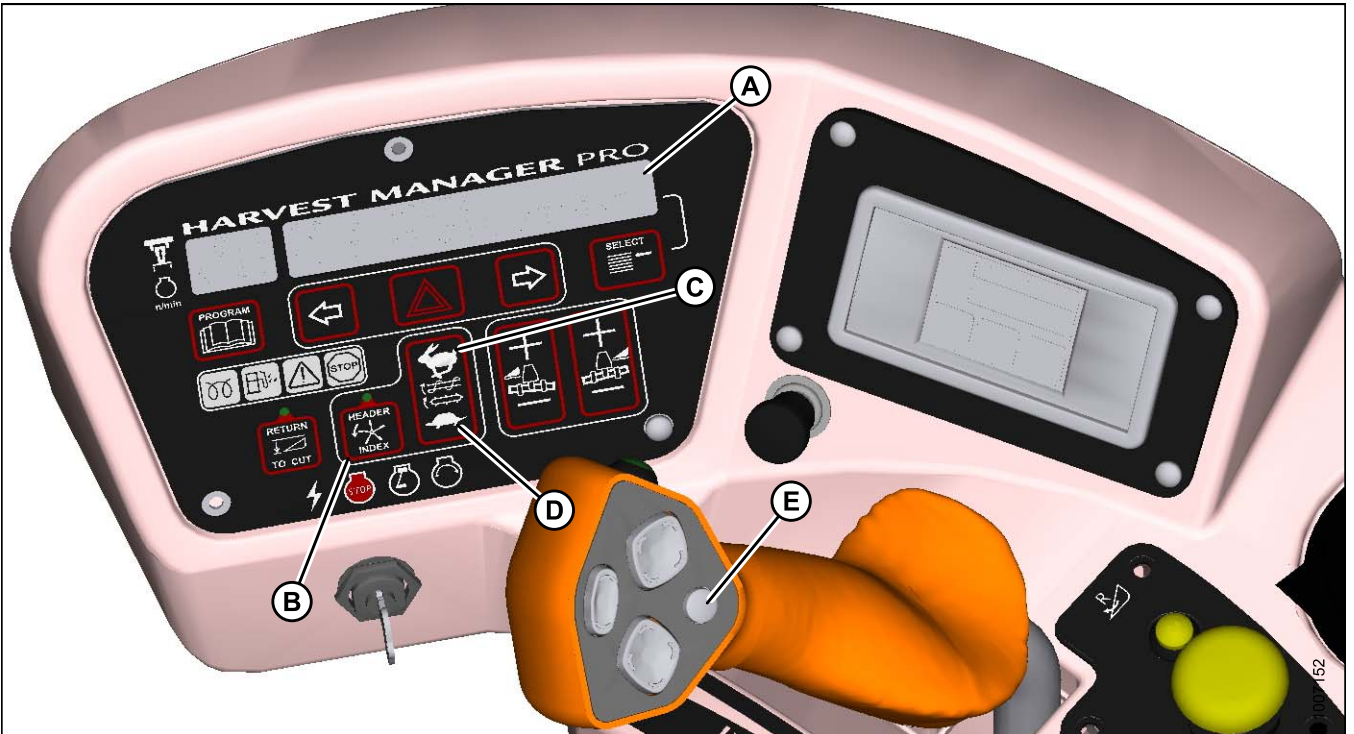

Figure 4.226: Operator Console

**CAUTION**

Check to be sure all bystanders have cleared the area.

Set draper index as follows:

**IMPORTANT:**

Draper Index can only be adjusted while operating at a ground speed faster than minimum draper speed plus header index value.

1. Engage header.
2. Set HEADER INDEX switch (B) to **ON**.
3. Press DISPLAY SELECTOR (E) on the ground speed lever (GSL) to display **DRAPER INDX**<sup>20</sup> at (A) on the cab display module (CDM).
4. Press DRAPER FAST (C) or SLOW (D) on the CDM until display (A) shows **###.## DRAP IND** with the desired index value.
  - The displayed value (###.##) = draper speed (mph or km/h<sup>21</sup>)
  - The displayed value (##.#) = the index value

20. DRAPER INDX will only be displayed when operating at a ground speed faster than minimum draper speed plus the header index value.  
 21. Depending on CDM programming.

## OPERATION

### Examples:

- Windrower is operating at 8 mph with header index ON and set at 1.5.  
Display shows: **9.5 1.5 DRAP INDX** where **9.5** ( $8 + 1.5$ ) is the draper speed in mph and **1.5** is the header index setting.
- Windrower speed drops to 7.5 mph at same header index setting.  
Display shows: **9.0 1.5 DRAP INDX** where **9.0** ( $7.5 + 1.5$ ) is the draper speed in mph and **1.5** is the header index setting.
- Windrower is operating at 8 mph with header index ON and set at 0.9.  
Display shows: **8.9 0.9 DRAP INDX** where **8.9** ( $8 + 0.9$ ) is the draper speed in mph and **0.9** is the header index setting.

### Setting Draper Speed Independent of Ground Speed



Figure 4.227: Operator Console

Set the speed of the draper independent of ground speed as follows:

#### NOTE:

This procedure can also be used to change the draper speed while in motion.

#### **CAUTION**

**Check to be sure all bystanders have cleared the area.**

1. Engage header.
2. Set HEADER INDEX switch (B) to **OFF**.
3. Press DISPLAY SELECTOR button (E) to show **##.# DRAPER SPEED** on the cab display module (CDM) (A).

## OPERATION

Displayed value (##.#) = draper speed (mph or km/h<sup>22</sup>).

4. Press FAST (C) or SLOW (D) on the CDM until desired draper speed is displayed at (A).

### 4.6.7 Knife Speed

The ideal cutting speed of the knife should achieve a clean cut. Crop types and conditions usually influence the knife and ground speeds.

**Table 4.2 Knife Speed Table**

Header Description		Knife Speed			
Type	Size (ft)	Minimum		Maximum	
		rpm <sup>23</sup>	spm <sup>24</sup>	rpm <sup>23</sup>	spm <sup>24</sup>
Draper with double knife	15	750	1500	950	1900
	20 and 25	700	1400	850	1700
	30	600	1200	800	1600
	35			700	1400
	40	550	1100	700	1400
Draper with single knife	20 and 25	600	1200	750	1500
	30			700	1400
	35	550	1100		
	40	525	1050	600	1200

When the header is first attached to the windrower, the windrower control module (WCM) receives a code from the header that determines the knife speed range and the minimum speed.

The desired speed can be programmed on the cab display module (CDM) and stored in the WCM memory so the knife will operate at the original set-point after the header is detached and reattached to the windrower.

If no header code is detected, the CDM displays NO HEADER and the knife speed reverts to the operator's selection from a range of 800–1000 strokes per minute.

Refer to the header operator's manual for the suggested knife speed for a variety of crops and conditions.

**NOTE:**

The knife speed cannot be programmed outside the range specified for each header.

**NOTE:**

The knife speed can be adjusted without shutting down the machine, though it is recommended that the windrower be stopped before adjusting CDM settings.

To adjust the knife speed, refer to [Setting the Header Knife Speed, page 107](#).

22. Depending on CDM programming.

23. Revolutions per minute is the speed of knife drive box pulley.

24. Strokes per minute of knife (rpm x 2).

## Setting Knife Speed “On the Go”



Figure 4.228: Operator Console

### ⚠ CAUTION

Check to be sure all bystanders have cleared the area.

Display and set knife speed “on the go” as follows:

1. Engage header.
2. Press PROGRAM (D) and SELECT (E) on cab display module (CDM) to show **#### KNIFE SPM** at (A).  
Displayed value (####) = strokes per minute.
3. Press SLOWER (B) or FASTER (C) until desired knife speed is displayed at (A).



## 4.6.8 Deck Shift Control

When connected to a draper header with the deck shift option, hydraulic deck shift control allows you to select the deck position and draper rotation of the header from the operator's station. It selects crop delivery from the left side, center, or right side of the header.

### Deck Shift

#### CAUTION

**Check to be sure all bystanders have cleared the area.**

Shift decks as follows:

1. Engage header by pushing down on the yellow HEADER DRIVE button while pulling up on the black ring at the base of the switch.
2. Push the switch (A) to desired delivery position. Deck(s) will move and direction of drapers will change accordingly.
3. Operate windrower.

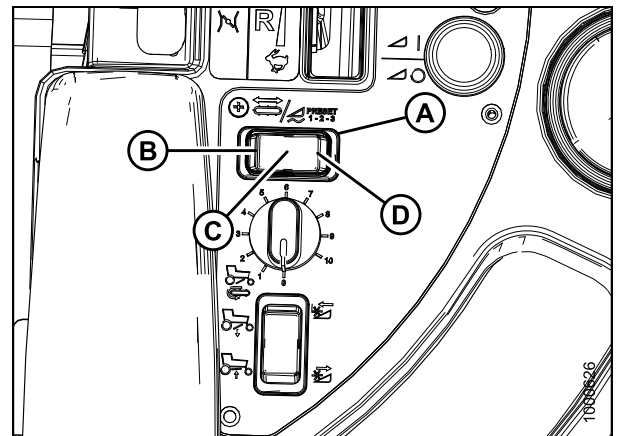

**Figure 4.229: Deck Shift Switch**

A - Deck Shift Switch  
 B - Left Side Delivery  
 C - Center Delivery  
 D - Right Side Delivery

### Setting Float Options with Deck Shift

For draper headers equipped with the deck shift option, the header float can be set for each deck position. Float is maintained when the decks are shifted.

#### CAUTION

**Check to be sure all bystanders have cleared the area.**

Program the float as follows:

1. Engage header.

## OPERATION

- Using HEADER TILT SWITCHES (A) and (B) on the ground speed lever (GSL), set center-link to mid-range position (05.0 on Display [E]).

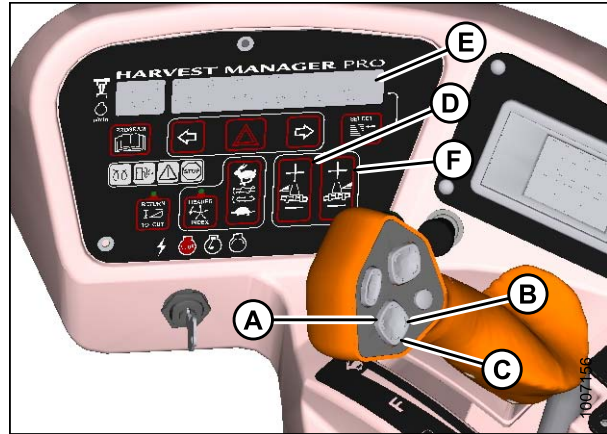

**Figure 4.230: Operator Console**

A - Header Tilt Down	B - Header Tilt Up
C - Header Down	D - Left Float
E - Display	F - Right Float

- Select a deck position with DECK SHIFT switch (A) from one of the following delivery options:
  - B - Left side delivery
  - C - Center delivery
  - D - Right side delivery

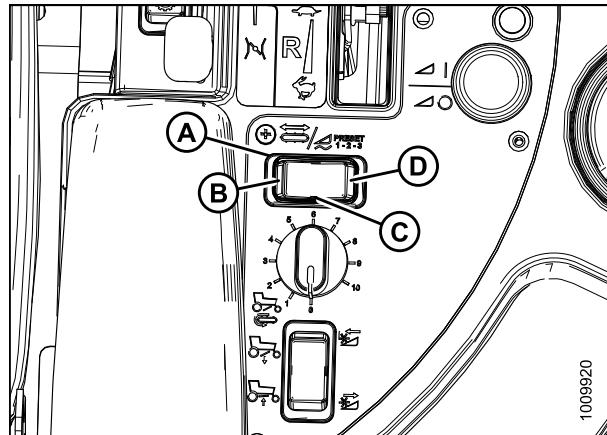

**Figure 4.231: Deck Shift Switch**

- Using HEADER DOWN switch (A) on the GSL, lower header fully with lift cylinders fully retracted.
- Using LEFT FLOAT SWITCH (B), push + to increase float or - to decrease float on left side of header. Display (D) will indicate selected float value for left side, for example (8.0 L FLOAT R ###).
- Repeat for right side float with RIGHT switch (C). Display (D) will indicate float value for both sides, for example (8.0 L FLOAT R 3.0).

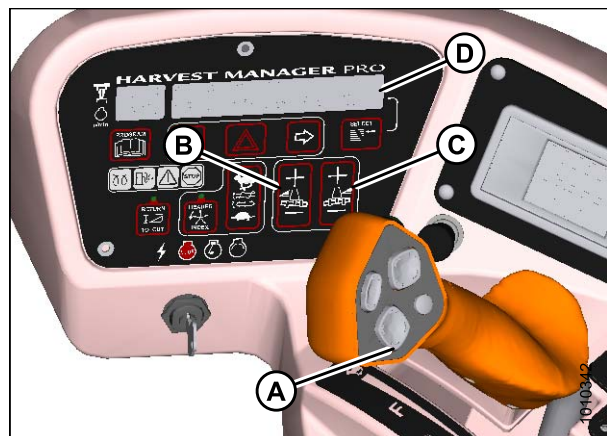

**Figure 4.232: Operator Console**

## OPERATION

7. Select a second deck position with the DECK SHIFT switch (A).
8. Repeat step 5., page 270 and step 6., page 270 to set the float for the second deck position.
9. Select a third deck position with the DECK SHIFT switch (A).
10. Repeat step 5., page 270 and step 6., page 270 to set the float for the third deck position.

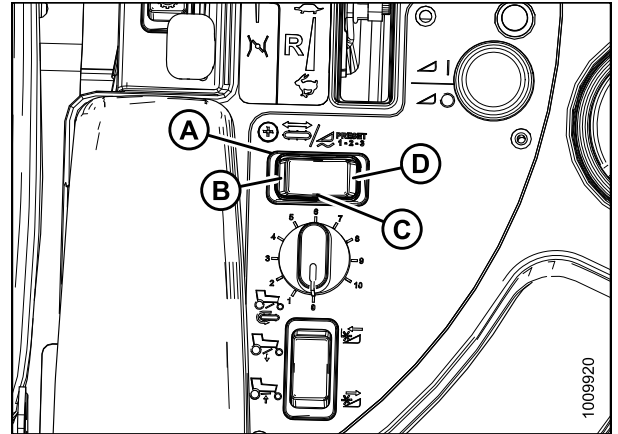

**Figure 4.233: Deck Shift Switch**

A - Deck Shift Switch

B - Left Side Delivery

C - Center Delivery

D - Right Side Delivery

## 4.7 Operating with an A-Series Header

The M155E4 is factory-equipped to run an A-Series Auger Header.

### 4.7.1 Auger Speed

#### *Auger Speed on A30-D Headers*

On A30-D Auger Headers, the auger speed is fixed to the knife speed. The auger speed is **NOT** monitored and cannot be displayed.

#### *Setting the Auger Speed on A40-D Headers*



Figure 4.234: Operator Console

### **CAUTION**

Check to be sure all bystanders have cleared the area.

To set the auger speed, follow these steps:

1. Engage header.
2. Set the HEADER INDEX switch (B) to **OFF**.
3. Set the REEL SPEED to the minimum setting [Reel and Disc Speed Switches, page 76](#).
4. Press DISPLAY SELECTOR switch (E) on the ground speed lever (GSL) or press FAST (C) or SLOW (D) on the cab display module (CDM) until **### AUGER SPEED** is displayed at (A).

The displayed value (###) = auger speed setting.

## OPERATION

### NOTE:

Changes to reel speed will affect the auger speed directly. However, when adjusting reel speed, the auger speed value displayed on the CDM will not change.

5. Press FAST (C) or SLOW (D) on the CDM until the desired auger speed is achieved.

### 4.7.2 Displaying Reel Speed: A30-S and A30-D Headers

The reel is driven by the auger, and both are dependent on the main header drive speed. The auger and reel speeds can be changed by installing a different size auger and reel drive sprockets, or by varying the windrower engine rpm.

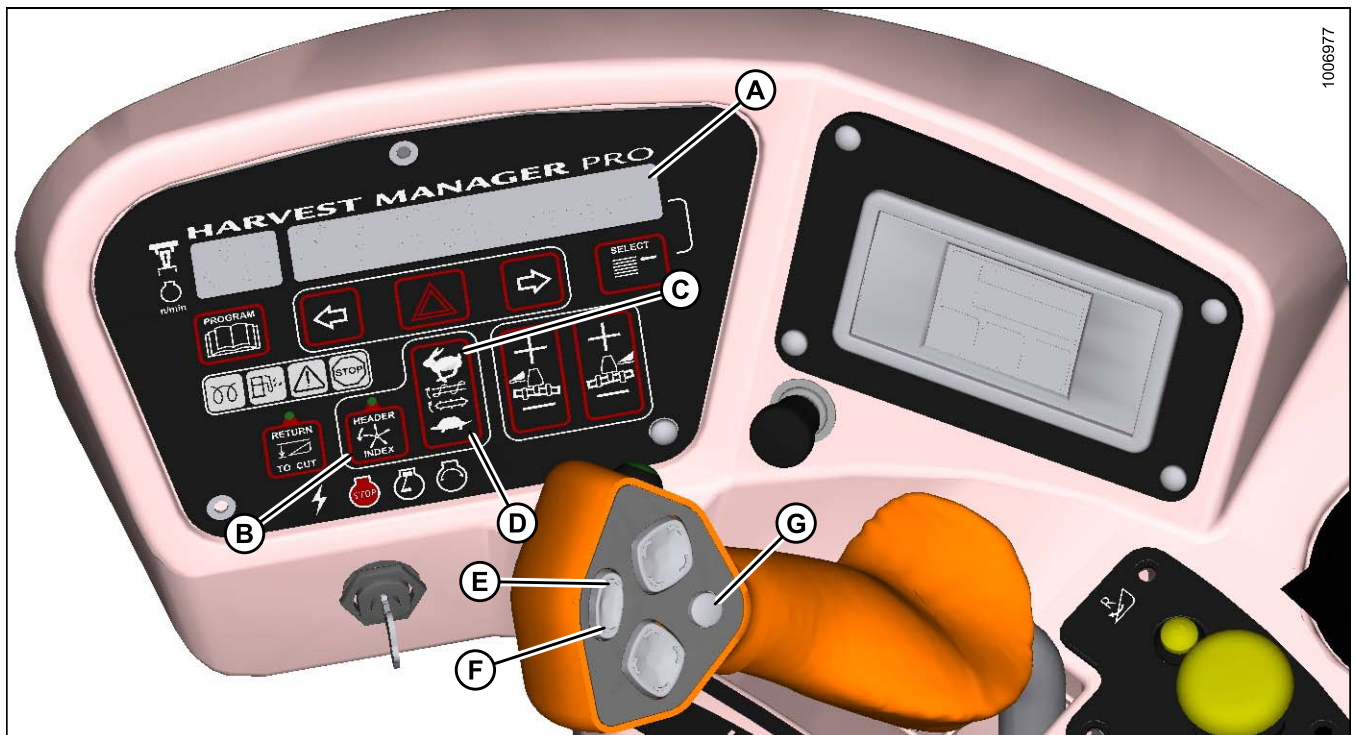

**Figure 4.235: Operator Console**

A - Display  
E - Fast

B - Header Index  
F - Slow

C - Auger Fast  
G - Display Selector

D - Auger Slow

Display the reel speed as follows:

1. Engage header.
2. Set HEADER INDEX (B) to **OFF**.
3. On the ground speed lever (GSL), press DISPLAY SELECTOR (G) or SELECT SWITCH on the cab display module (CDM) until **###.## REEL RPM** displays at (A).  
**##.## = 15.00 – 85.00**

### 4.7.3 Reel Speed

Refer to your header operator's manual for recommended reel speed settings for your particular crop.

#### *Reel Speed on A40-D Headers*

The A40-D Auger Header features a hydraulic direct drive reel with an operating speed range of 15–85 rpm. Reel speed is controlled by the cab display module (CDM) and the ground speed lever (GSL) in the operator's station.

**NOTE:**

Adjusting the reel speed will result in a change to auger speed unless the auger speed has been preset.

#### Adjusting Reel Only Speed

The A40–D reel drive is hydraulically driven. Adjusting reel speed also changes auger speed, unless the auger speed is initially set at a predetermined value. The following procedure sets the auger speed so that subsequent reel speed adjustments will only affect the reel.

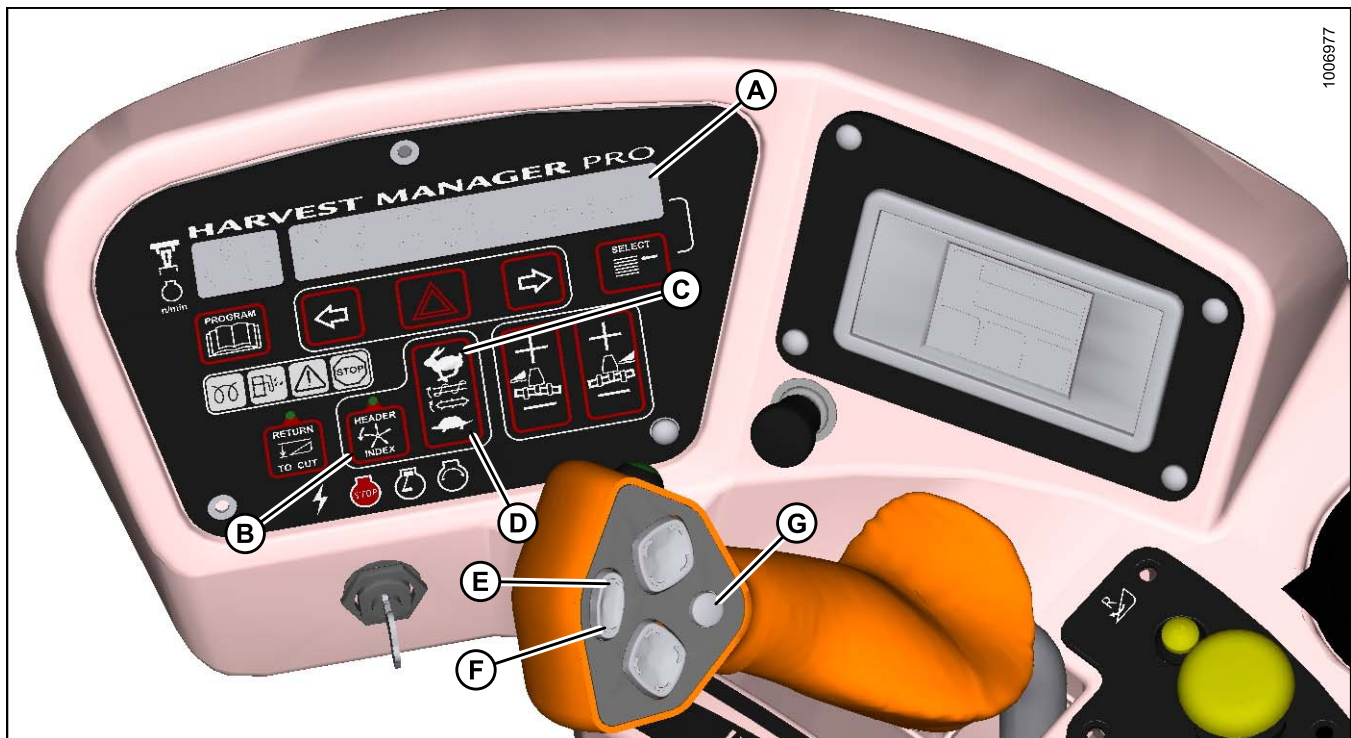

**Figure 4.236: Operator Console**

- |                      |                  |                |
|----------------------|------------------|----------------|
| A - Display          | B - Header Index | C - Auger Fast |
| D - Auger Slow       | E - Fast         | F - Slow       |
| G - Display Selector |                  |                |

**IMPORTANT:**

To prevent over-speeding the auger, initially set the speed of the reel and auger as follows: Subsequent adjustments to reel speed do **NOT** affect auger speed.

1. Engage header.
2. Set HEADER INDEX SWITCH (B) to **OFF**.

## OPERATION

3. On ground speed lever (GSL) press REEL SLOW switch (F) until a beep is heard.
4. Display (A) shows **### REEL RPM**.
5. On cab display module (CDM) press AUGER SLOW (D) or FAST (C) switch to set desired auger speed.
6. Display (A) shows **### AUGER SPEED**.
7. On GSL press REEL SLOW (F) or FAST (E) switch to set desired reel speed.
8. Display (A) shows **### REEL RPM**.

### NOTE:

The auger speed will **NOT** change if the reel speed is adjusted.

### Adjusting Reel Speed: Windrower in Motion

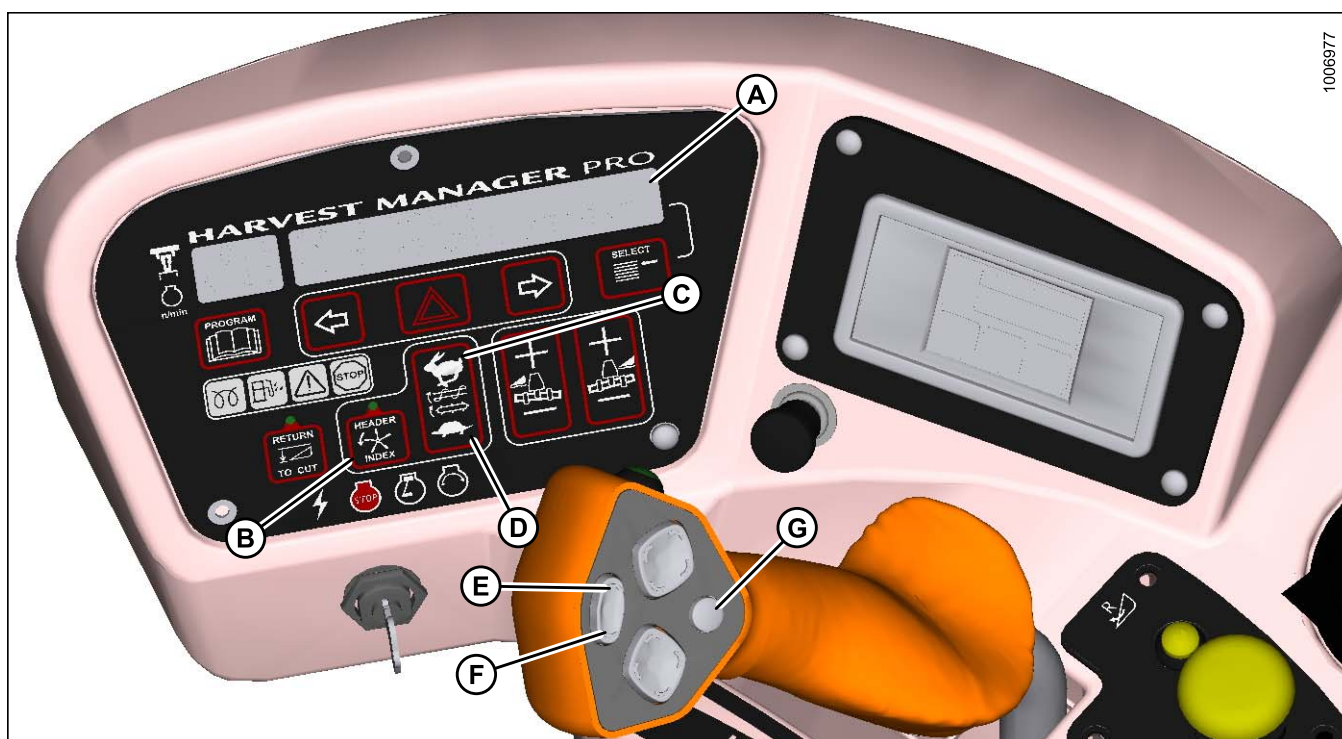

Figure 4.237: Operator Console

A - Display  
E - Reel Fast

B - Header Index  
F - Reel Slow

C - Auger Fast  
G - Display Selector

D - Auger Slow

The reel speed adjustment range is from 15 to 85 rpm. Adjust the reel speed while the machine is in operation as follows:

1. Set HEADER INDEX switch (B) to **OFF**.
2. Press REEL SLOW (F) or REEL FAST (E) on the ground speed lever (GSL) until display (A) shows **### REEL RPM** with desired reel speed.

The displayed value (**###**) = reel speed (rpm or mph or km/h<sup>25</sup>).

25. Depending on CDM programming.

## OPERATION

### NOTE:

Adjusting reel speed will alter auger speed unless the auger speed has been preset.

### Setting Reel to Ground Speed

Setting the speed of the reel relative to ground speed (using the header index function) automatically adjusts the reel speed with changes to ground speed. Benefits may include improved crop flow and reduced operator fatigue.

Setting the reel to ground speed requires setting the minimum reel speed and the reel index.

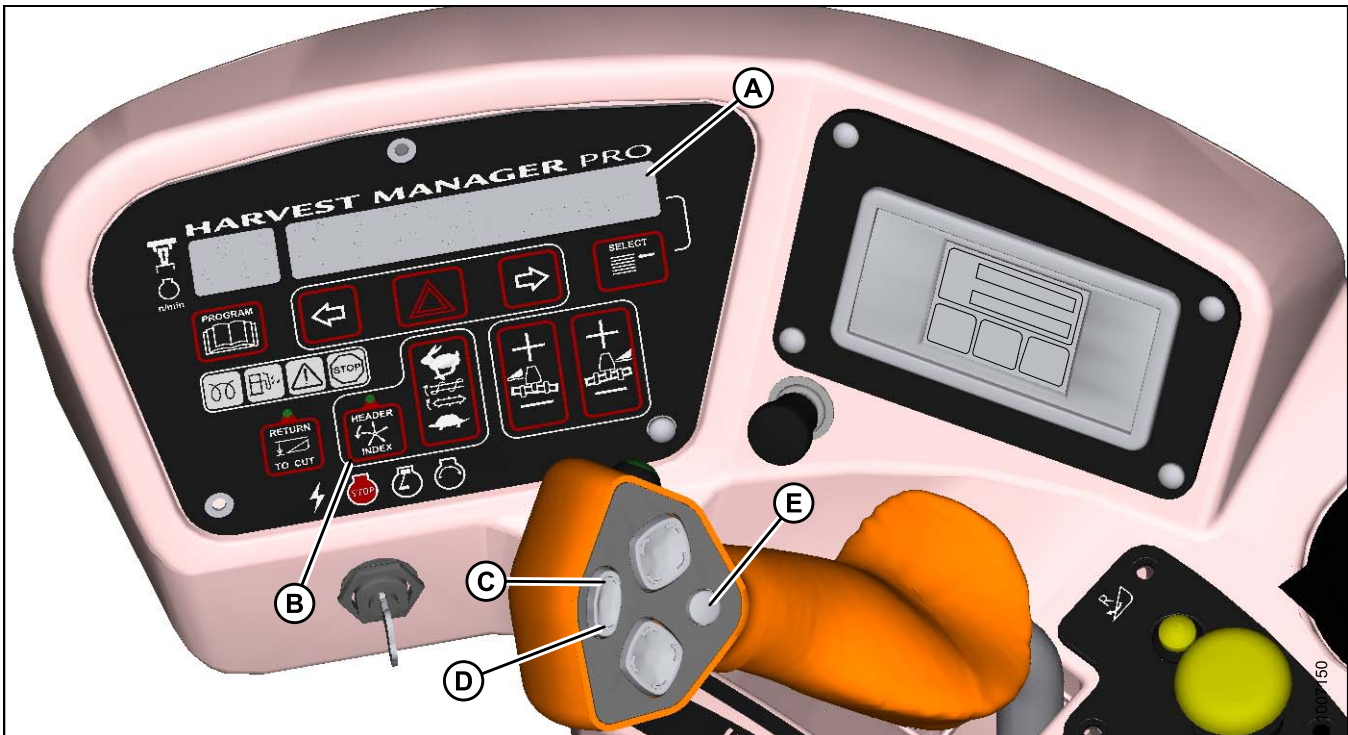

Figure 4.238: Operator Console

### **!** CAUTION

Check to be sure all bystanders have cleared the area.

1. Set the minimum reel speed as follows:

#### **IMPORTANT:**

Set the minimum reel speed while stationary with the ground speed lever (GSL) in the N-DETENT position.

- a. Engage header.
- b. Set HEADER INDEX switch (B) to **ON**.
- c. Press the DISPLAY SELECTOR button (E) on the GSL to display **###.### MIN REEL** at (A) or press the FAST (C) or SLOW (D) switch.  
The displayed value (**###.###**) = reel speed (rpm or mph or km/h<sup>26</sup>).
- d. Press FAST (C) or SLOW (D) until the desired minimum reel speed is achieved.

26. Depending on CDM programming.



## OPERATION

- Set the reel index as follows:

### IMPORTANT:

Reel index can only be adjusted while operating at a ground speed faster than minimum reel speed plus header index value.

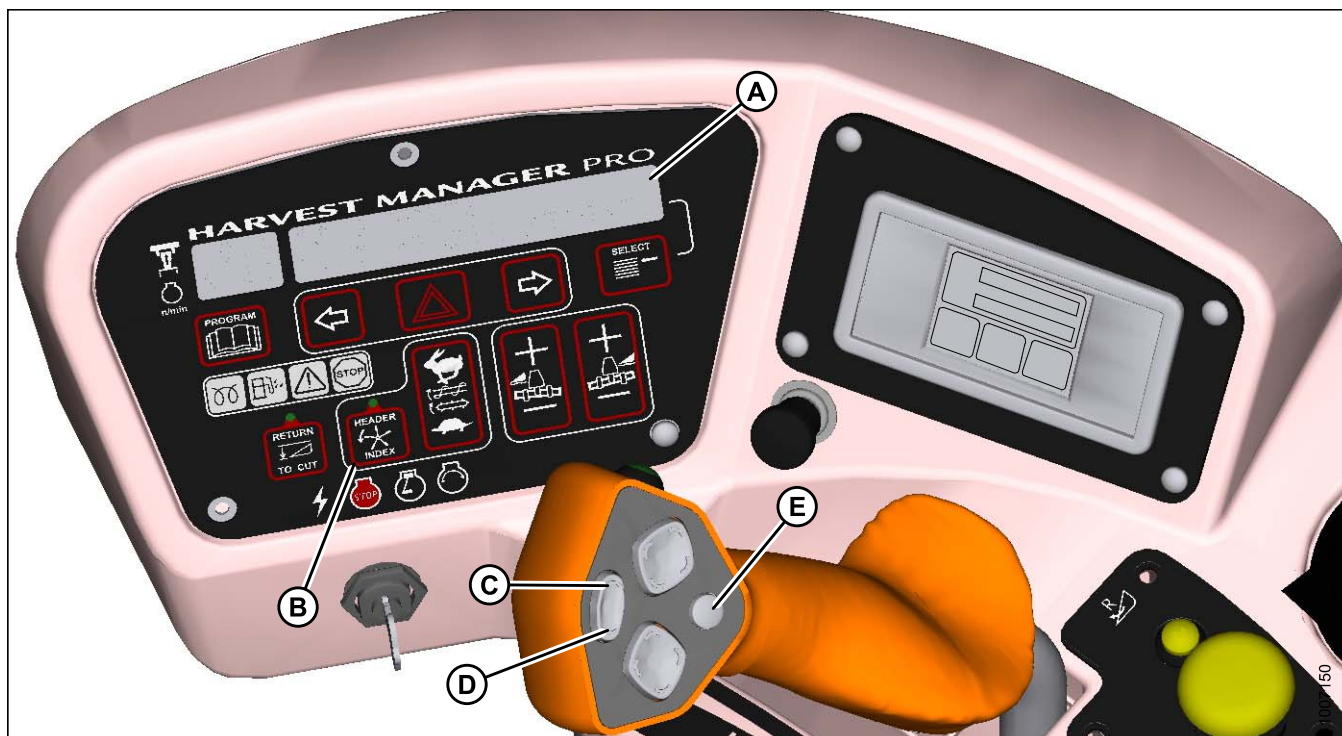

Figure 4.239: Operator Console

- Set the HEADER INDEX switch (B) to **ON**.
- Press the DISPLAY SELECTOR button (E) on the GSL to display **###.## REEL IND<sup>27</sup>** or press the FAST (C) or SLOW (D) switch.
  - The displayed value (**###.##**) = reel speed (mph or km/h or rpm<sup>26</sup>)
  - The displayed value (**###.##**) = reel index value
- Press FAST (C) or SLOW (D) until the desired reel index value is achieved.

### NOTE:

The reel will continue operating at the minimum reel speed setting when ground speed drops below the set value. The cab display module (CDM) display (A) will flash **###.## MIN REEL (RPM or MPH or KPH<sup>26</sup>)** prompting you to change the minimum set-point or increase ground speed if the total of ground speed, plus the index value is **LESS THAN** the minimum reel speed set-point.

27. REEL IND will only be displayed when operating at a ground speed faster than minimum reel speed plus header index value.

## OPERATION

### Examples:

- Windrower is operating at 8 mph with HEADER INDEX ON, and set at -1.0.  
Display shows: **7.0 -1.0 REEL IND** where **7.0** (8.0-1.0) is the reel speed in mph and **-1.0** is the header index setting.
- Windrower speed drops to 7.5 mph at same HEADER INDEX setting.  
Display shows: **6.5 -1.0 REEL IND** where **6.5** (7.5-1.0) is the reel speed in mph and **-1.0** is the header index setting.
- Windrower is operating at 8 mph with HEADER INDEX ON, and set at 2.0.  
Display shows: **10.0 2.0 REEL IND** where **10.0** (8+2.0) is the reel speed in mph and **2.0** is the header index setting.

### 4.7.4 Knife Speed

The ideal cutting speed should achieve a clean cut. Crop types and conditions usually influence the knife and ground speeds.

When the header is first attached to the windrower, the windrower control module (WCM) receives a code from the header that determines the knife speed range and the minimum speed.

The desired speed can be programmed on the cab display module (CDM) and stored in the WCM memory so the knife will operate at the original set-point after the header is detached and reattached to the windrower.

If no header code is detected, the CDM displays NO HEADER and the knife speed reverts to the operator's selection from a range of 800–1000 strokes per minute.

Refer to the header operator's manual for the suggested knife speed for a variety of crops and conditions.

#### NOTE:

The knife speed cannot be programmed outside the range specified for each header.

#### NOTE:

The knife speed can be adjusted without shutting down the machine, though it is recommended that the windrower be stopped before adjusting CDM settings.

To adjust the knife speed, refer to [Setting the Header Knife Speed, page 107](#).

## Setting Knife Speed “On the Go”



Figure 4.240: Operator Console

**CAUTION**

Check to be sure all bystanders have cleared the area.

Display and set knife speed “on the go” as follows:

1. Engage header.
2. Press PROGRAM (D) and SELECT (E) on cab display module (CDM) until display (A) shows **#### KNIFE SPM**.  
The displayed value (####) = strokes per minute.
3. Press SLOWER (B) or FASTER (C) until desired knife speed is displayed at (A).

## 4.8 Operating with an R-Series Header

The R85 13-foot header and the R80 13- and 16-foot headers are shipped without the motor and hoses installed. The installation of a separate motor and hose bundle is necessary.

If required, obtain kit MD #B5510 from your MacDon Dealer, and install it in accordance with the instructions supplied with the kit.

A Disc Drive kit (MD #B4657) is also required for windrower to operate the header.

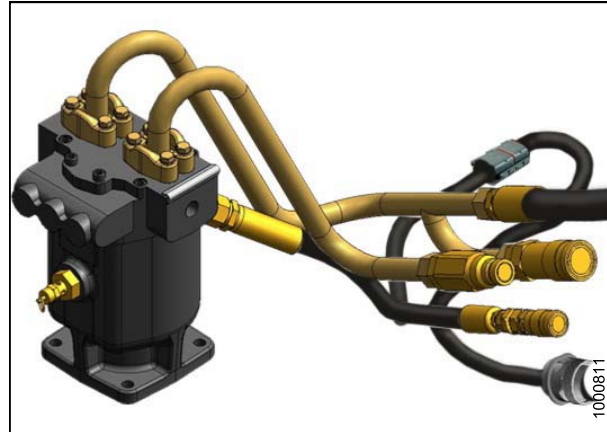

Figure 4.241: Kit MD #B5510

### 4.8.1 Disc Speed

The ideal disc speed should achieve a clean cut. Crop types and conditions usually influence the disc and ground speeds.

When the windrower is first attached to the header, the windrower control module (WCM) receives a code from the header determining the speed range and minimum speed.

The desired speed is programmed on the cab display module (CDM) and stored in the WCM memory so the discs will operate at the original set-point after the header is detached and reattached to the windrower.

If no header code is detected, the CDM displays NO HEADER, and the disc speed reverts to a preset range that can be changed by the Operator.

Refer to the header operator's manual for the suggested disc speed for a variety of crops and conditions.

## Setting Disc Speed

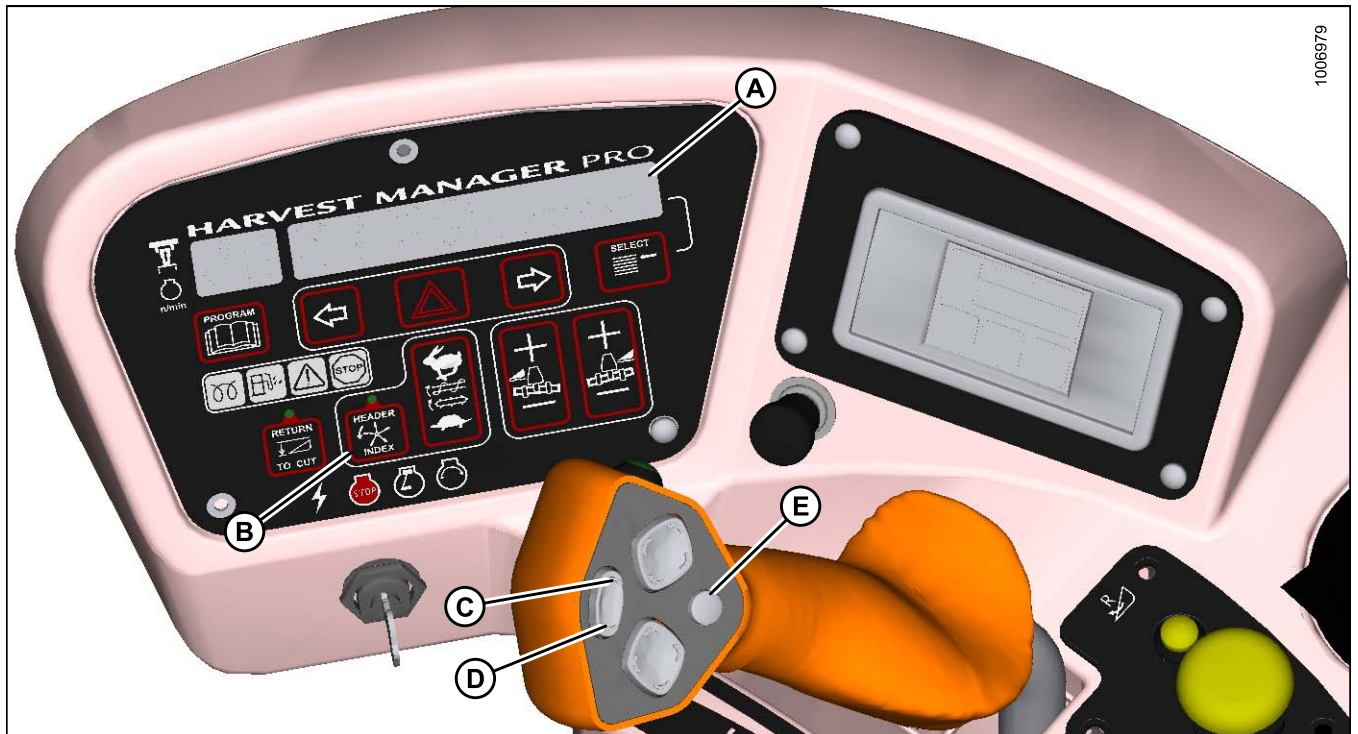

Figure 4.242: Operator Console

A - Display  
D - Slow

B - Header Index  
E - Display Selector

C - Fast

### CAUTION

Check to be sure all bystanders have cleared the area.

Follow these steps to set the disc speed:

1. Engage header.
2. Set HEADER INDEX switch (B) to **OFF**.
3. Press FAST (C) or SLOW (D) on ground speed lever (GSL) until display (A) shows **#### DISC RPM** with desired disc speed.

Displayed value (####) = disc speed (rpm).



## 5 Maintenance and Servicing

### 5.1 Preparation for Servicing

#### **WARNING**

To avoid personal injury, before servicing adapter/header or opening drive covers:

- Fully lower the header. If necessary to service in the raised position, always engage lift safety props.
- Disengage drives.
- Stop engine, and remove key.
- Wait for all moving parts to stop.

## 5.2 Engine Compartment Hood

The engine hood has two open positions. The lowest is for general maintenance such as checking and adding fluid, servicing the cooling box, etc. The highest position provides full access to the engine bay.

### 5.2.1 Opening Hood (Lower Position)

#### DANGER

To avoid bodily injury or death from unexpected startup of the machine, always stop the engine and remove the key from the ignition before leaving the operator's seat for any reason.

1. Stop the engine and remove the key.
2. Locate latch (A) behind grill and lift to release hood.
3. Raise hood until strap (B), which should be looped under hooks (C) and (D), stops at approximately a 40° angle.
4. Remove strap from hook (C) and allow hood to rise slightly further.

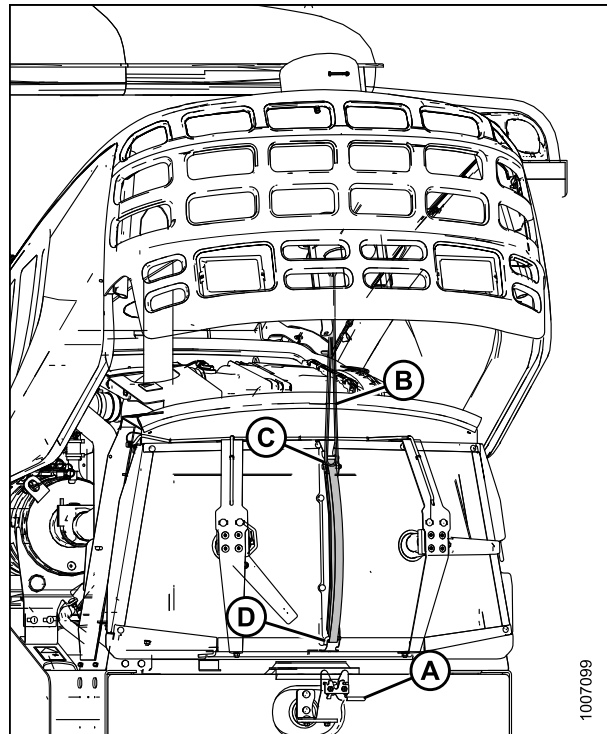

Figure 5.1: Hood Open (Lower Position)



### 5.2.2 Closing Hood (Lower Position)

1. Grasp the strap at (B) and loop under upper hook (C).

**IMPORTANT:**

Failure to hook strap may result in it becoming entangled with the screen cleaners or the latch.

2. Pull down on strap (B), grasp the hood when within reach and lower until hood engages latch (A).

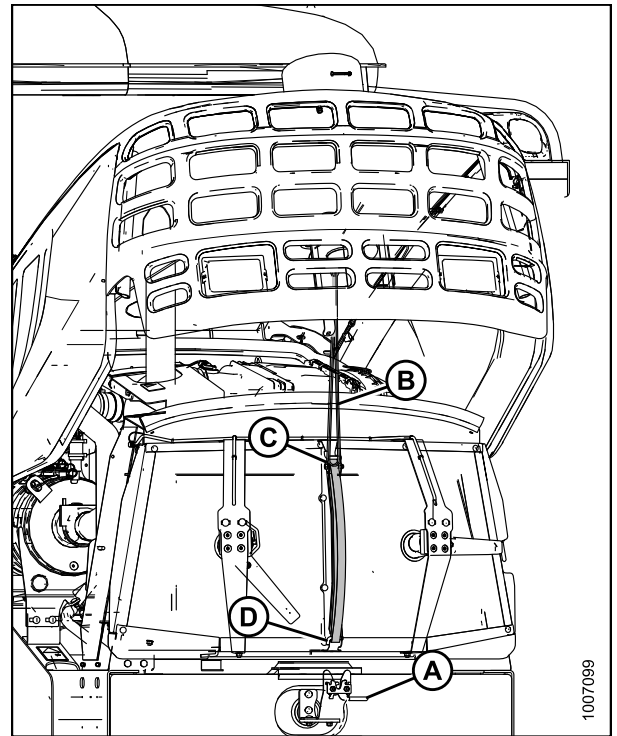

Figure 5.2: Hood Open (Lower Position)

### 5.2.3 Opening Hood (Highest Position)

**⚠ DANGER**

To avoid bodily injury or death from unexpected startup of the machine, always stop the engine and remove the key from the ignition before leaving the operator's seat for any reason.

1. Stop the engine and remove the key.

## MAINTENANCE AND SERVICING

2. Locate latch (A) behind grill and lift to release hood.
3. Raise hood until strap (B), which should be looped under hooks [C] and [(D], stops at approximately a 40° angle.
4. Remove strap from hook (C) and allow hood to rise slightly further.
5. Remove strap from hook (D) and allow hood to rise fully to approximately 65°.

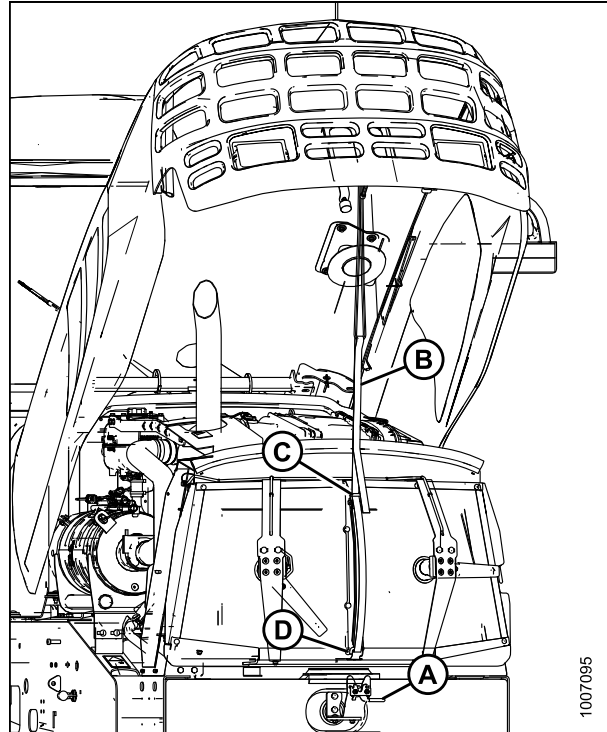

Figure 5.3: Hood Open (Highest Position)

### 5.2.4 Closing Hood (Highest Position)

1. Pull down on strap (B) and loop under lower hook (D).
2. Grasp the strap and loop under upper hook (C).

**IMPORTANT:**

Failure to hook strap may result in it becoming entangled with the screen cleaners or the latch.

3. Pull down on strap, grasp the hood when within reach, and lower until hood engages latch (A).

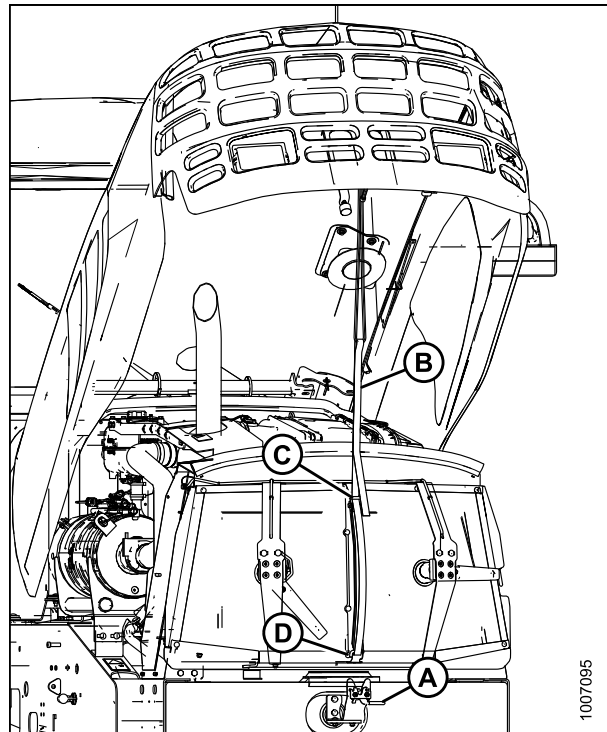

Figure 5.4: Hood Open (Highest Position)

## 5.3 Maintenance Platforms

Swing-away platform/stair units are provided on both sides of the windrower for access to the operator's station and engine bay.

The platforms can be swung away from the windrower to allow access to the hydraulics plumbing or battery.

The maintenance platforms have three positions:

- Closed position
- Open standard position
- Open major servicing position

### 5.3.1 Opening Platforms (Standard Position)

#### CAUTION

Do NOT stand on an unlocked side platform. It is unstable and may cause you to fall.

#### NOTE:

This procedure describes how to open the cab-forward left platform (A). Use the same procedure for the right platform (B).

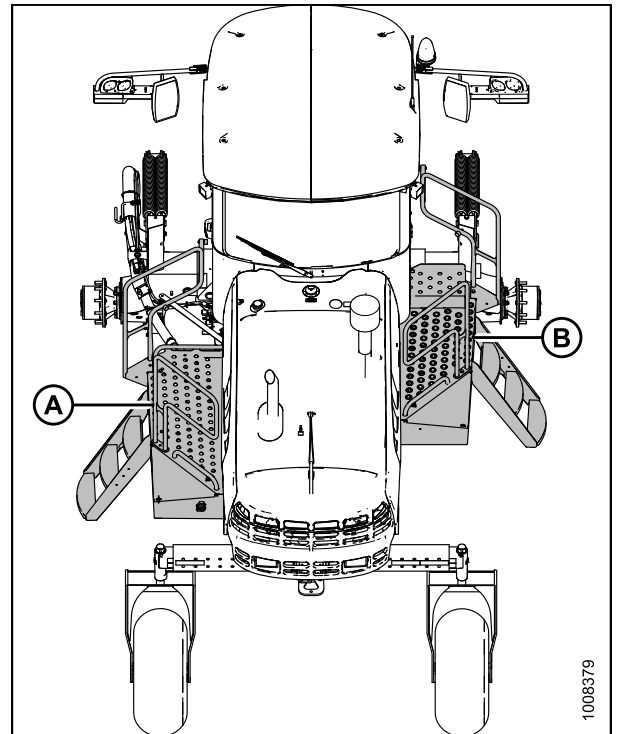

Figure 5.5: Platforms

## MAINTENANCE AND SERVICING

1. Push latch (A) and pull platform (B) toward walking beam until it stops and latch engages in open position.

**NOTE:**

Ensure the platform is latched before using.

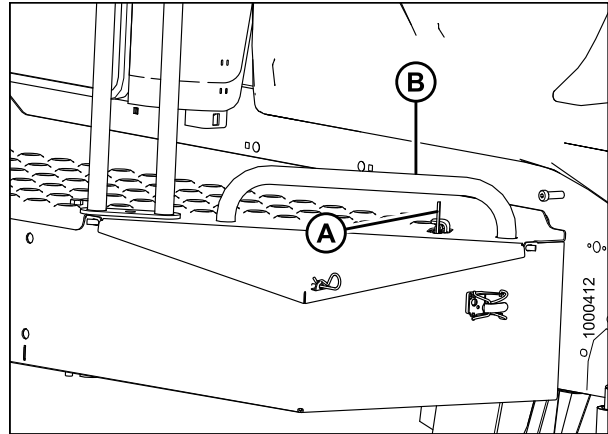

Figure 5.6: Platform Latch

### 5.3.2 Closing Platforms (Standard Position)

**⚠ CAUTION**

Do NOT stand on an unlocked side platform. It is unstable and may cause you to fall.

**NOTE:**

This procedure describes how to close the cab-forward left platform (A): use the same procedure for the right platform (B).

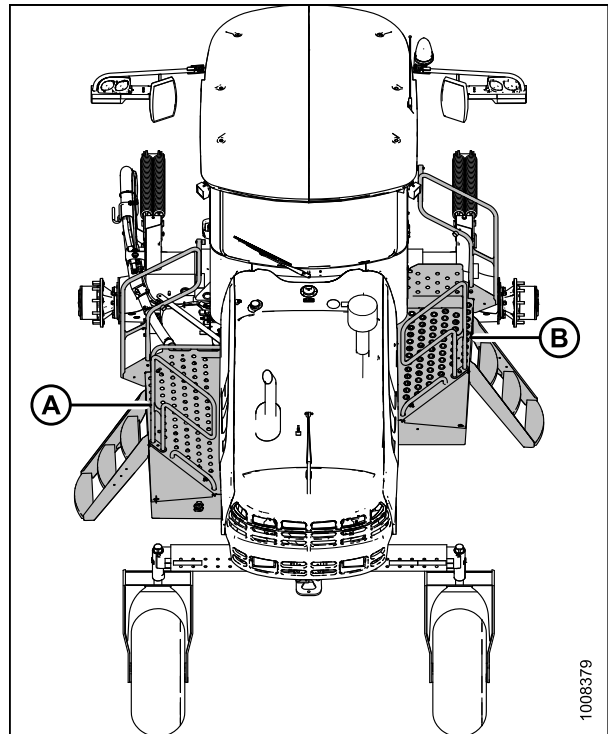

Figure 5.7: Platforms

## MAINTENANCE AND SERVICING

1. If platform is latched in the open position, push latch (A) to unlock it.
2. Grasp handle (B) on platform and push forward until it stops and latch (A) engages.

**NOTE:**

Ensure the platform is latched properly before using.

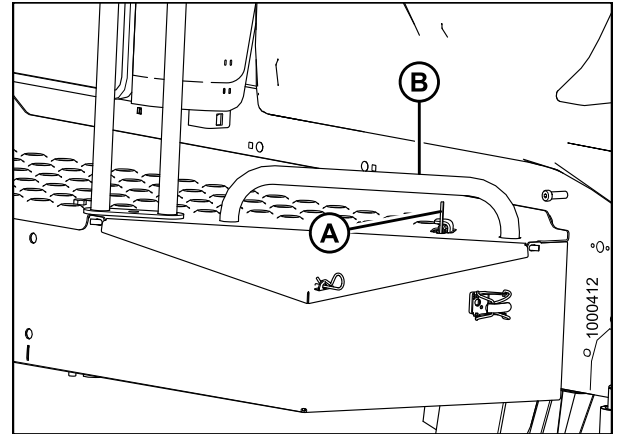

Figure 5.8: Platform Latch

### 5.3.3 Opening Platforms (Major Service Position)

To improve access to the hydraulics plumbing or battery, the platforms can be swung away from the windrower.

**CAUTION**

Do NOT stand on an unlocked side platform. It is unstable and may cause you to fall.

1. Open the hood. Refer to [5.2.1 Opening Hood \(Lower Position\)](#), page 284.

**IMPORTANT:**

Failure to open hood will result in damage to the hood when the platform is moved.

**NOTE:**

This procedure describes how to open the cab-forward left platform (A): use the same procedure for the right platform (B).

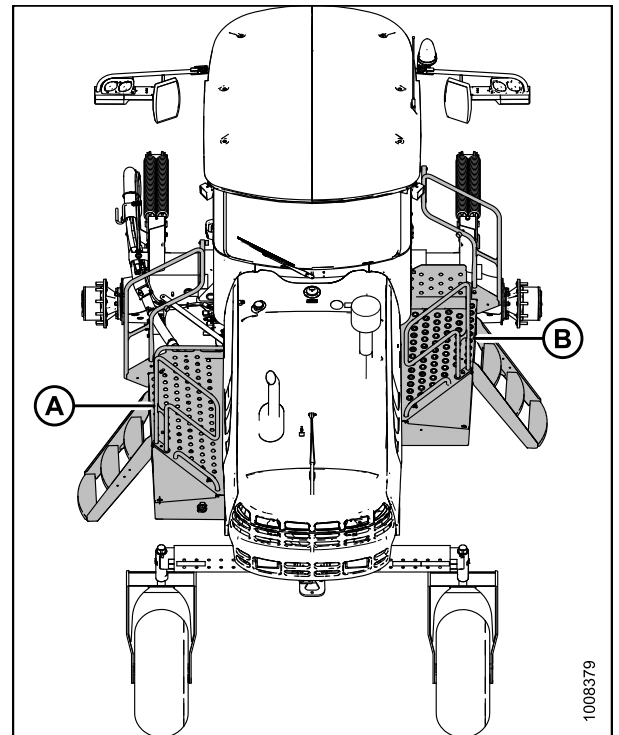

Figure 5.9: Platforms

## MAINTENANCE AND SERVICING

2. Unlock latch (A) and move platform (B) toward open position. Do **NOT** lock in full aft position.

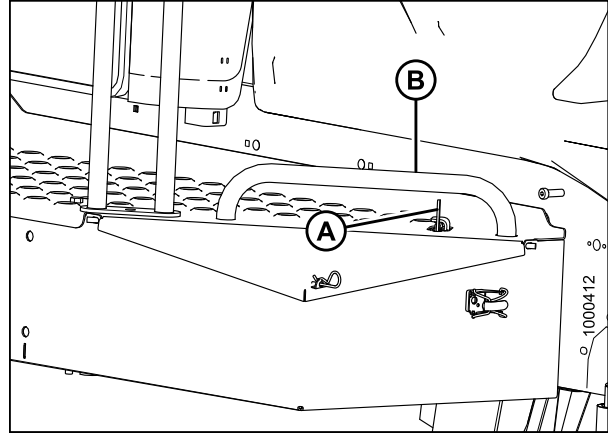

Figure 5.10: Platform Latch

3. Remove the nut and bolt that secure link (A) to the frame. Swing link (A) out of the way.
4. Pull the front (cab-forward) end of platform away from frame while moving it towards the walking beam. The aft corner of platform (B) should project slightly into the engine bay when the opening is optimum.

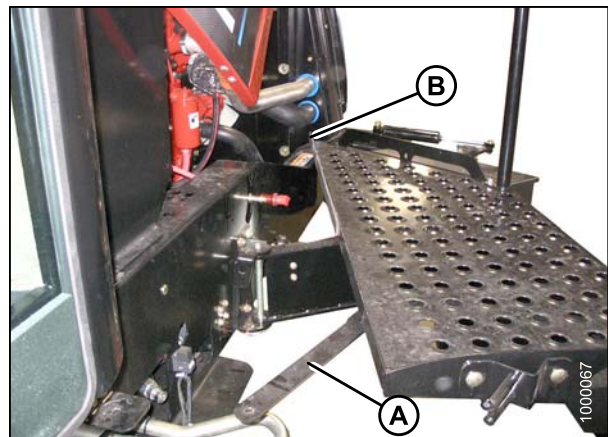

Figure 5.11: Platform

### 5.3.4 Closing Platforms (Major Service Position)

#### CAUTION

Do **NOT** stand on an unlocked side platform. It is unstable and may cause you to fall.

1. Swing link (A) all the way forward.
2. Push the front (cab-forward) end of platform towards the frame while moving the platform forward (cab-forward).
3. Position link (A) on bracket and install bolt and nut. Tighten enough so that link can still swivel on bracket.

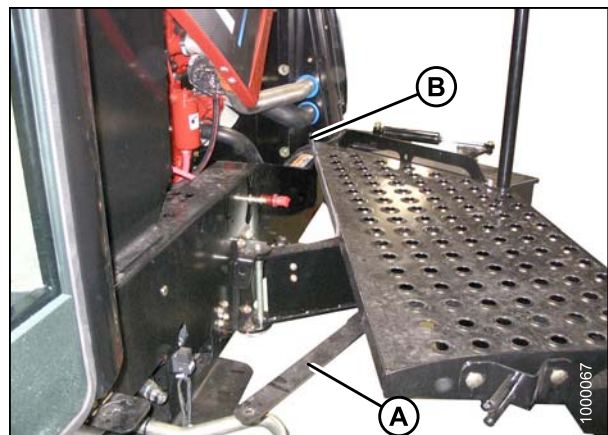
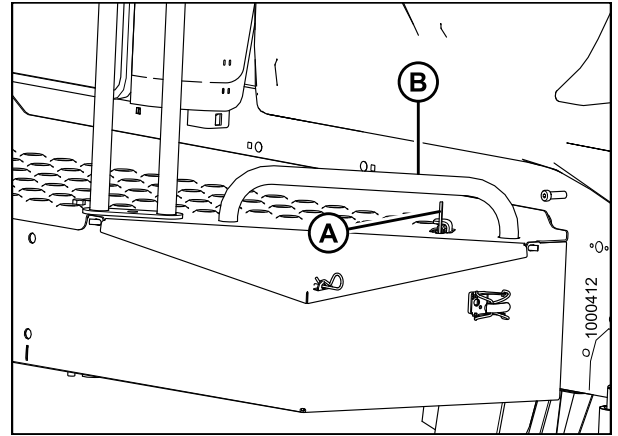

Figure 5.12: Platform

## MAINTENANCE AND SERVICING

4. Move platform (B) forward (cab-forward) until it stops and latch (A) engages.
5. Close the hood. Refer to [5.2.2 Closing Hood \(Lower Position\)](#), [page 285](#).



**Figure 5.13: Platform Latch**

## 5.4 Windrower Lubrication

### WARNING

To avoid personal injury, before servicing windrower or opening drive covers, follow procedures in the SAFETY section.

The greasing points are marked on the machine by decals showing a grease gun and grease interval in hours of operation.

Log hours of operation and use the Maintenance Checklist provided to keep a record of scheduled maintenance. Refer to [5.12.1 Maintenance Schedule/Record, page 414](#).

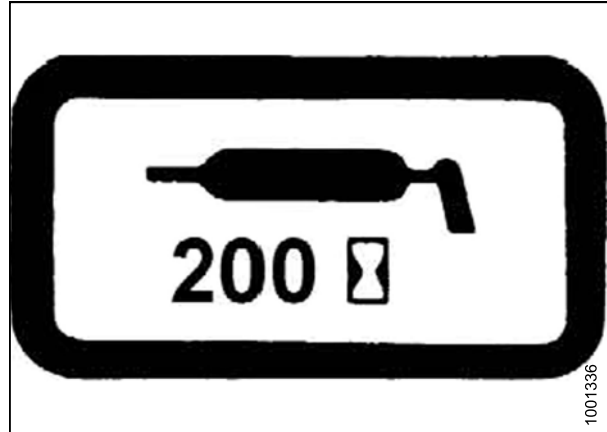

Figure 5.14: Lubrication Interval Decal

### 5.4.1 Lubricating the Windrower

#### DANGER

To avoid bodily injury or death from unexpected startup of the machine, always stop the engine and remove the key from the ignition before leaving the operator's seat for any reason.

1. To avoid injecting dirt and grit, wipe grease fitting with a clean cloth before greasing.
2. Inject grease through fitting with grease gun until grease overflows fitting, except where noted. Refer to [8.1.3 Lubricants, Fluids, and System Capacities, page 444](#).
3. Leave excess grease on fitting to keep out dirt.
4. Replace any loose or broken fittings immediately.
5. If fitting will **NOT** take grease, remove and clean thoroughly. Also clean lubricant passageway. Replace fitting if necessary.



### 5.4.2 Lubrication Points

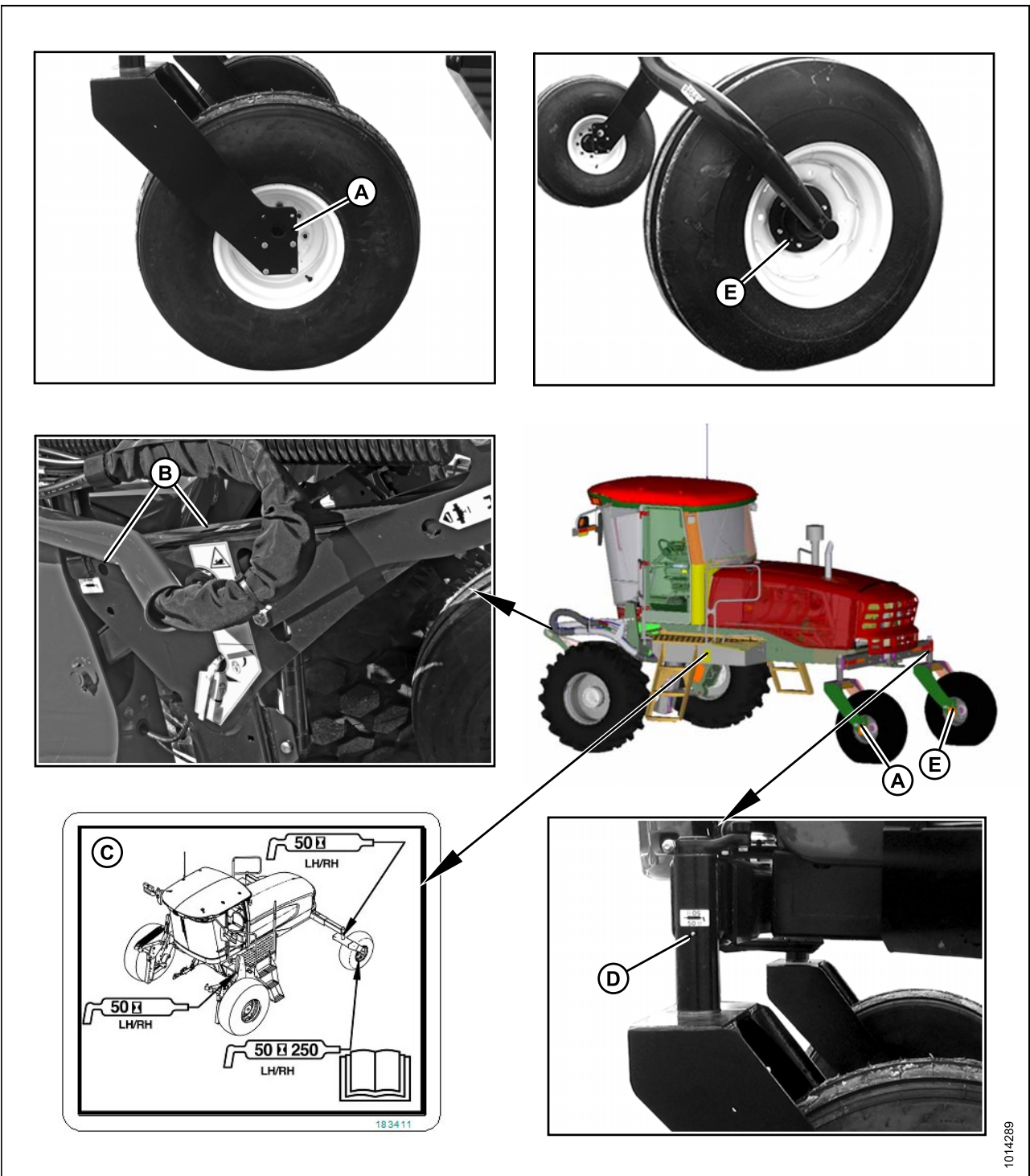

**Figure 5.15: Lubrication Points**

A - Forked Caster Wheel Bearing (2 Places) (Outer – Both Wheels)

B - Top Link (2 Places) (Both Sides)

C - Lubrication Decal (MD #183411)

D - Caster Pivot (Both Sides)

E - Forked/Formed Caster Wheel Bearing (2 Places) (Inner – Both Wheels) (50 Hrs/250 Hrs)

1014289

## 5.5 Operator's Station

### 5.5.1 Seat Belts

- Keep sharp edges and items that can cause damage away from the belts.
- Check belts, buckles, retractors, tethers, slack take-up system, and mounting bolts for damage.
- Check that bolts are tight on the seat bracket or mounting.
- Replace all parts that have damage or wear.
- Replace belts that have cuts that can weaken the belt.
- Keep seat belts clean and dry. Clean only with a soap solution and warm water. Do **NOT** use bleach or dye on the belts, as this may weaken the material.

### 5.5.2 Safety Systems

Perform the following checks on the operator's presence and engine lock-out systems every year or every 500 hours—whichever occurs first.

#### *Checking Operator Presence System*



#### **CAUTION**

**Check to be sure all bystanders have cleared the area.**

1. While the windrower engine running, place the ground speed lever (GSL) in NEUTRAL and turn the steering wheel until it locks.
2. With everyone clear of the machine, engage header drive switch:
  - a. After header drives are running, stand up out of the seat. In approximately 5 seconds, the header should shut off.
  - b. If **NOT**, the Operator Presence System requires adjustment. See your MacDon Dealer.

#### **NOTE:**

To restart the header, move the HEADER DRIVE switch to OFF position and back to the ON position again.

3. With the engine running, position the GSL in NEUTRAL and in N-DETENT:
  - a. Swivel the operator's station, but do **NOT** lock into position.
  - b. Move GSL out of N-DETENT. The engine should shut down and the lower display will flash LOCK SEAT BASE → CENTER STEERING WHEEL → NOT IN NEUTRAL.
  - c. Swivel and lock the operator's station and the display should return to normal.
  - d. If the engine does **NOT** shut down, the seat position switches require adjustment. See your MacDon Dealer.
4. With the windrower moving at less than 5 mph (8 km/h):
  - a. Stand up out of the seat.
  - b. The cab display module (CDM) will flash NO OPERATOR on the upper line and ENGINE SHUT DOWN 5...4...3...2...1...0 on the lower line accompanied by a steady tone. At 0, the engine shuts down.
  - c. If the engine does **NOT** shut down, the Operator Presence System requires adjustment. See your MacDon Dealer.

## MAINTENANCE AND SERVICING

5. With the windrower moving at more than 5 mph (8 km/h):
  - a. Stand up out of the seat.
  - b. The CDM should beep once and display NO OPERATOR on the lower line.
  - c. If **NOT**, the Operator Presence System requires adjustment. See your MacDon Dealer.

### *Checking Engine Interlock*

#### **CAUTION**

**Check to be sure all bystanders have cleared the area.**

1. With the engine shut down and the header drive switch engaged, try to start the engine. If the engine turns over, the system requires adjustment. See your MacDon Dealer.
2. With the engine shut down, steering wheel **NOT** centered, and the ground speed lever (GSL) in NEUTRAL, but **NOT** in N-DETENT, try to start the engine. The cab display module (CDM) will flash NOT IN NEUTRAL on the display upper line and CENTER STEERING WHEEL on the lower line, accompanied by a short beep with each flash and the engine should **NOT** turn over. If the engine turns over, the system requires adjustment. See your MacDon Dealer.

A properly functioning system should operate as follows. If not, see your MacDon Dealer.

- The starter should engage **ONLY** when the GSL is in N-DETENT, steering wheel locked in the CENTER position and the header drive switch is in the OFF position.
- The brake should engage and the machine should **NOT** move after engine start-up, under the above conditions.
- The steering wheel should **NOT** lock with the engine running and the GSL out of the N-DETENT.
- The machine should **NOT** move with the engine running and with the steering wheel still centered, when the GSL is pulled straight out of N-DETENT (**NOT** in forward or reverse).

### **5.5.3 Ground Speed Lever (GSL) Adjustments**

#### *Adjusting Ground Speed Lever (GSL) Lateral Movement*

#### **DANGER**

**To avoid bodily injury or death from unexpected startup of the machine, always stop the engine and remove the key from the ignition before leaving the operator's seat for any reason.**

The ground speed lever (GSL) should easily move into the N-DETENT by itself.

Adjust the lateral pivot resistance as follows:

## MAINTENANCE AND SERVICING

1. Remove the five screws (A) securing control panel (B) to console, remove panel, and store in the tray.

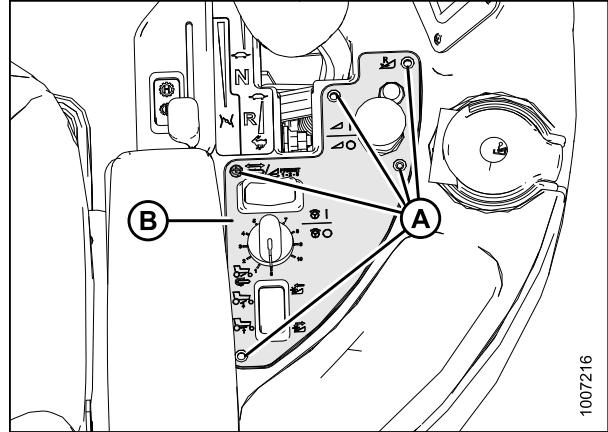

**Figure 5.16: Control Panel**

2. Back off the jam nut (A) and turn nut (B) to either tighten or loosen the pivot. The nut should be tightened to snug and then backed off 1/2 turn.
3. Tighten jam nut (A).
4. Check movement of GSL.

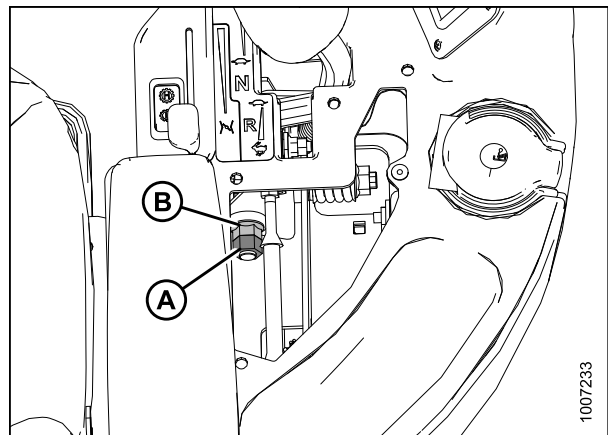

**Figure 5.17: Control Panel Removed**

5. Reinstall the control panel (B) with the five screws (A).

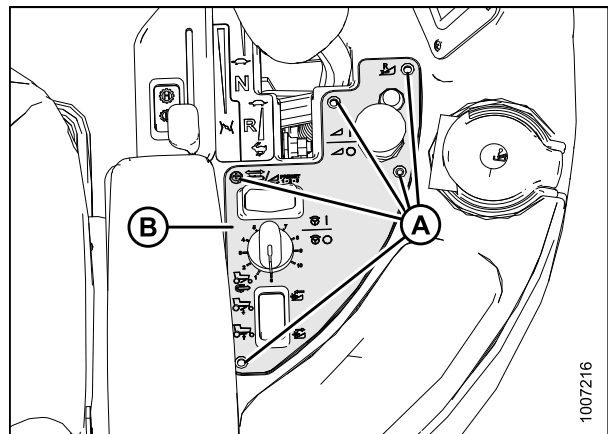

**Figure 5.18: Control Panel**

### *Adjusting Ground Speed Lever (GSL) Fore-Aft Movement*

The GSL should remain as positioned by the Operator yet be movable without excessive force.

Adjust as follows:

## MAINTENANCE AND SERVICING

1. Pull handle (A) toward the operator's seat and move the console fully forward to ease accessibility from the underside of the console.

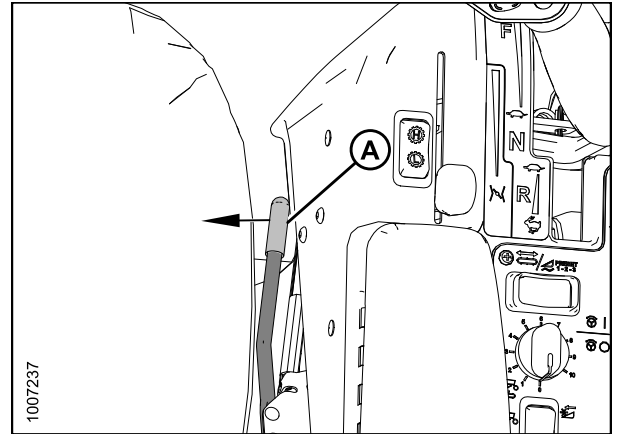

Figure 5.19: Seat Adjustment Handle

2. Set spring dimension (B) to 1-1/4 in. (32 mm).
3. To increase the pivot resistance, turn the nut (A) clockwise to compress the spring.
4. To decrease the resistance, turn the nut (A) counterclockwise to release the spring tension.

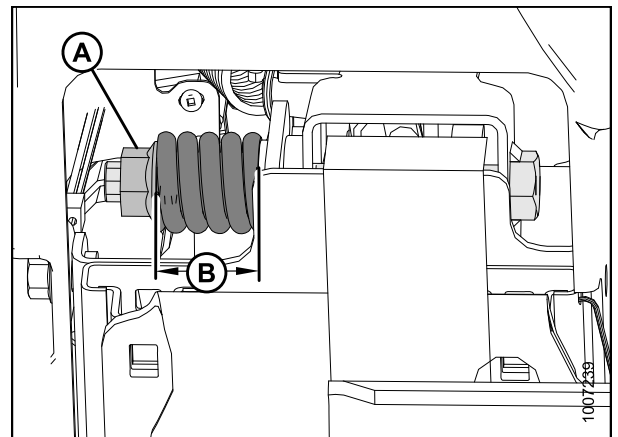

Figure 5.20: GSL Adjustment Spring

B - Spring Dimension 1-1/4 in. (32 mm)

### 5.5.4 Steering Adjustments

#### *Checking Steering Link Pivots*

The following checks should be performed every year:

#### **DANGER**

To avoid bodily injury or death from unexpected startup of the machine, always stop the engine and remove the key from the ignition before leaving the operator's seat for any reason.

## MAINTENANCE AND SERVICING

1. Place ground speed lever (GSL) (A) in N-DETENT, shut down engine, and remove key.

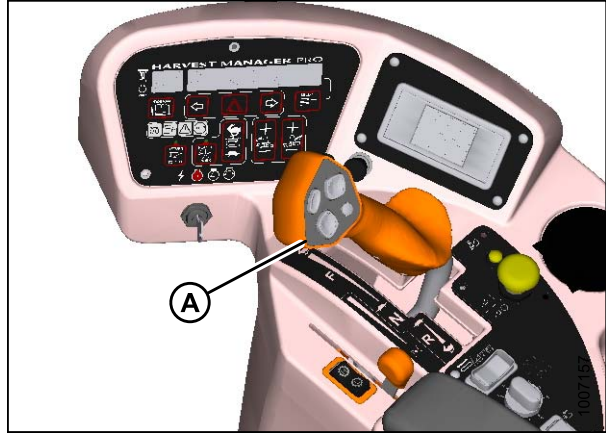

Figure 5.21: Operator Console

2. Check steering rod bolts (A) for looseness and ball joints (B) for any perceptible movement.

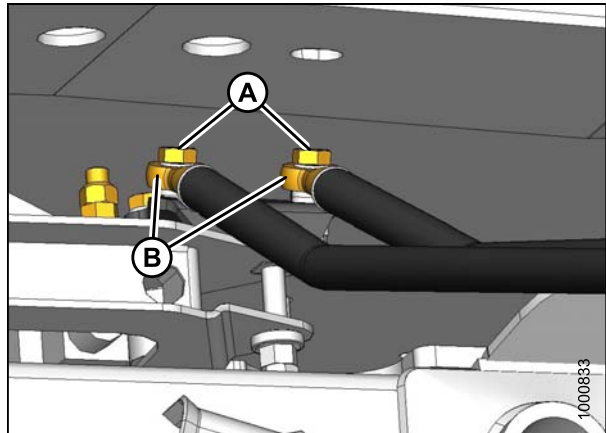

Figure 5.22: Steering Rods

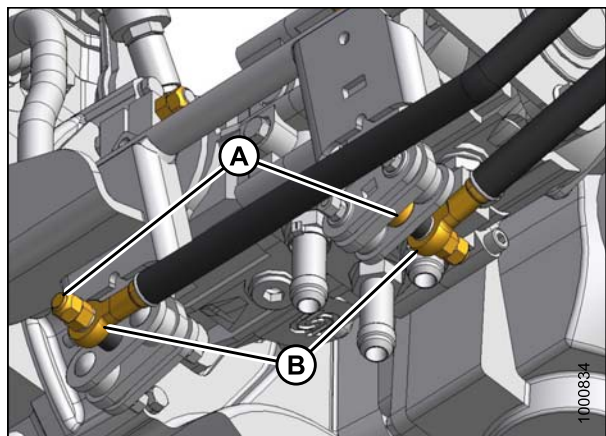

Figure 5.23: Steering Rods (Pump End)

## MAINTENANCE AND SERVICING

3. Check steering link bolts (A) for looseness and ball joints (B) for any perceptible movement.

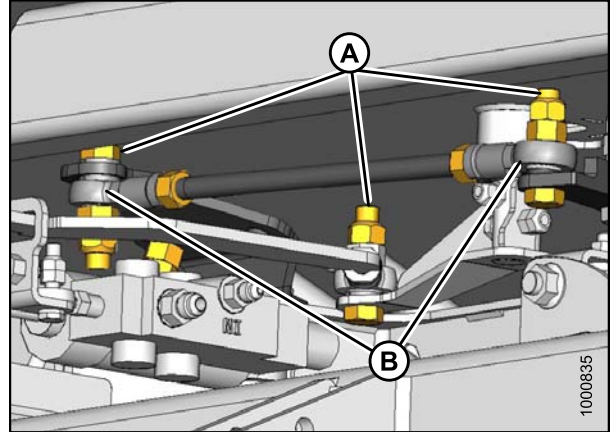

Figure 5.24: Steering Link

4. If bolts are loose:
  - a. Back off jam nut (A).
  - b. Tighten inside nut (B) to 70–80 ft·lbf (95–108 N·m).
  - c. Hold inside nut (B) and tighten jam nut (A) to 60–70 ft·lbf (81–95 N·m).

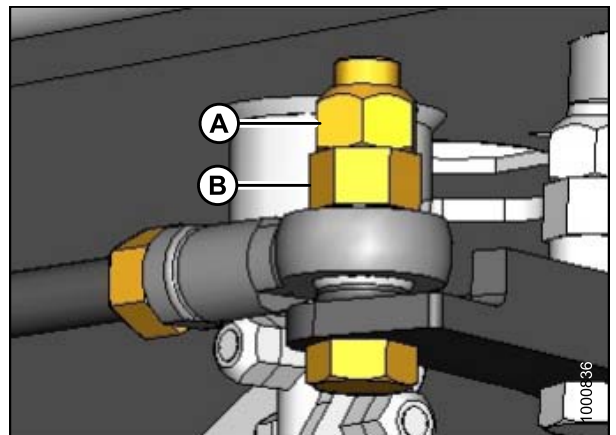

Figure 5.25: Steering Link

5. See your MacDon Dealer to replaced any loose steering link ball joints or steering rod ball joints.
6. After replacing parts or making adjustments, perform checks for Neutral Interlock and steering lock. Refer to [5.5.2 Safety Systems, page 294](#).

### Checking and Adjusting Steering Chain Tension

#### **DANGER**

To avoid bodily injury or death from unexpected startup of the machine, always stop the engine and remove the key from the ignition before leaving the operator's seat for any reason.

1. Check steering for binding or excessive play which may be the result of the steering chain being too tight or too loose. If the steering chain does **NOT** require adjustment, skip the following steps.
2. If the chain tension requires adjustment, swivel the operator's station to position steering column close to the door.

## MAINTENANCE AND SERVICING

3. At the base of the steering column, check dimension (C) at spring. It should be 5/8 in. (16 mm). Adjust dimension as follows:
  - a. Loosen nut (A) and turn nut (B) to achieve 5/8 in. (16 mm) dimension (C).
  - b. Tighten nut (A) against nut (B) to secure position.
  - c. Check that steering chain is taut and steering shaft is free to rotate.

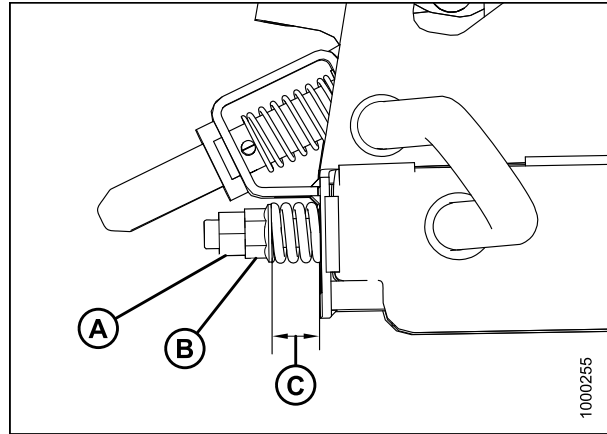

Figure 5.26: Steering Tension Adjuster

### 5.5.5 Cab Suspension Limit Straps

The cab suspension limit straps are located next to the front suspension on both sides of the cab. These straps protect cab suspension components by preventing the cab shocks from fully extending. The straps do not require regular maintenance, but they should be inspected every 100 hours.

1. Inspect the material on straps (A) for fraying or tearing.
2. If material is torn or frayed, contact your MacDon Dealer for replacement straps.

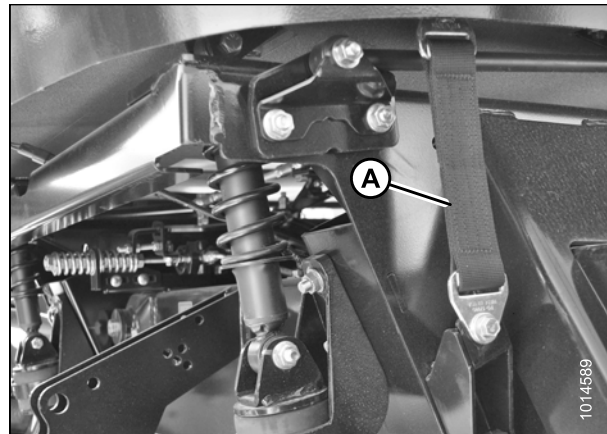

Figure 5.27: Cab Suspension



## 5.6 Heating, Ventilating, and Air Conditioning (HVAC) System

### 5.6.1 Fresh Air Intake Filter

The fresh air filter is located outside the right rear of the cab and should be serviced every 50 hours under normal conditions and more frequently in severe conditions.

#### *Removing Fresh Air Filter*

#### **DANGER**

To avoid bodily injury or death from unexpected startup of the machine, always stop the engine and remove the key from the ignition before leaving the operator's seat for any reason.

1. Open the right cab-forward platform. Refer to [5.3.1 Opening Platforms \(Standard Position\)](#), page 287.
2. Rotate latch (A) and slide filter tray (B) out of the housing.

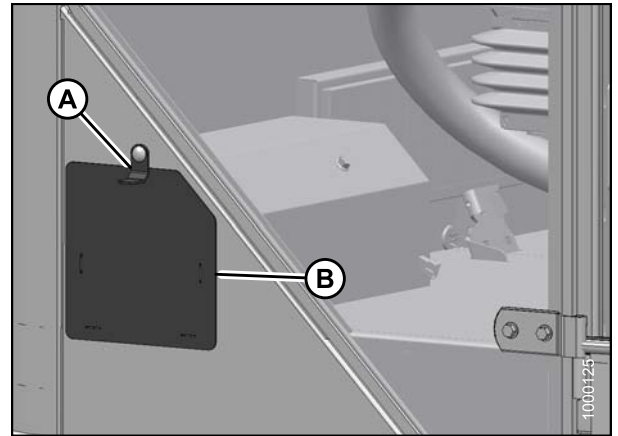

**Figure 5.28: Filter Tray**

3. Remove filter (A) from tray (B).

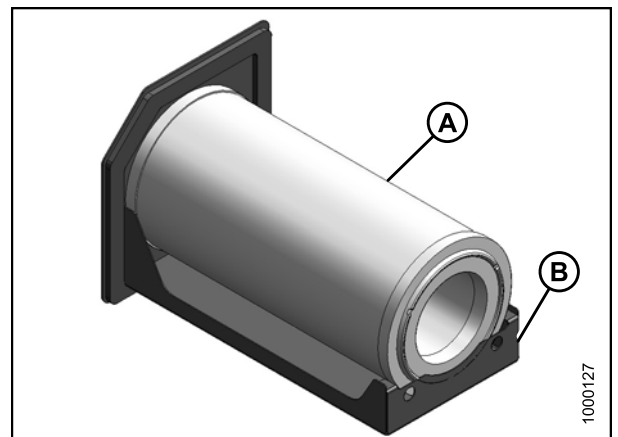

**Figure 5.29: Fresh Air Filter**

#### *Inspecting and Cleaning Fresh Air Filter Element*

1. Tap the sides of the filter element gently to loosen dirt. Do **NOT** tap element against a hard surface.
2. Using a dry element cleaner gun, clean element with compressed air.

## MAINTENANCE AND SERVICING

### IMPORTANT:

Air pressure must **NOT** exceed 60 psi (414 kPa). Do **NOT** direct air against outside of element, as dirt might be forced through to inside.

3. Hold the air nozzle next to the filter element's inner surface and move up and down pleats.
4. Repeat previous steps to remove additional dirt as required.
5. Hold a bright light inside the element and check carefully for holes. Discard any element that shows the slightest hole.
6. Check outer screen for dents. Vibration would quickly wear a hole in the filter.
7. Check filter gasket for cracks, tears, or other signs of damage. If gasket is damaged or missing, replace element.

### Installing Fresh Air Filter

Refer to [8.1.4 Filter Part Numbers, page 445](#) for part number.

1. Clean tray (B) and interior of filter housing.
2. Place filter (A) onto tray (B).

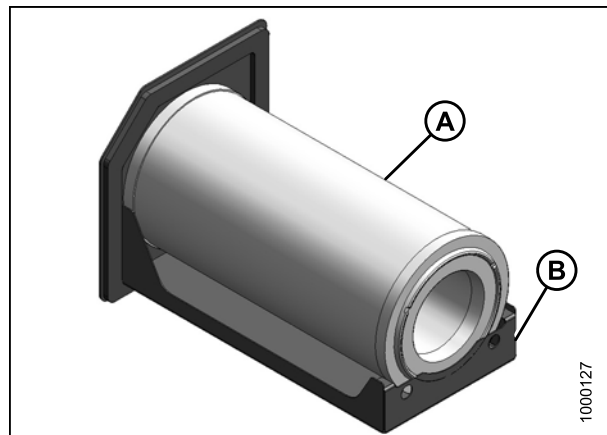

Figure 5.30: Fresh Air Filter

3. Slide filter tray (B) into housing.

### NOTE:

If necessary, move the GPS wiring harnesses to the left (engine) side of the housing before inserting the filter tray.

4. Close and latch housing door (A).

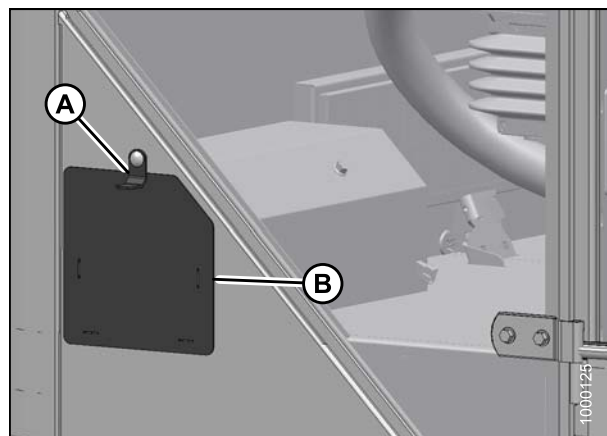

Figure 5.31: Cab Fresh Air Filter Access

## 5.6.2 Return Air Cleaner/Filter

The return air cleaner/filter is located behind the operator's seat on the cab wall and should be serviced every 100 hours.

### Replacing Return Air Cleaner/Filter

#### DANGER

To avoid bodily injury or death from unexpected startup of the machine, always stop the engine and remove the key from the ignition before leaving the operator's seat for any reason.

If replacing the return air filter, refer to [8.1.4 Filter Part Numbers, page 445](#) for the part number.

1. Unscrew the two knobs (A) attaching cover and filter to cab wall, and remove the cover and filter assembly (B).

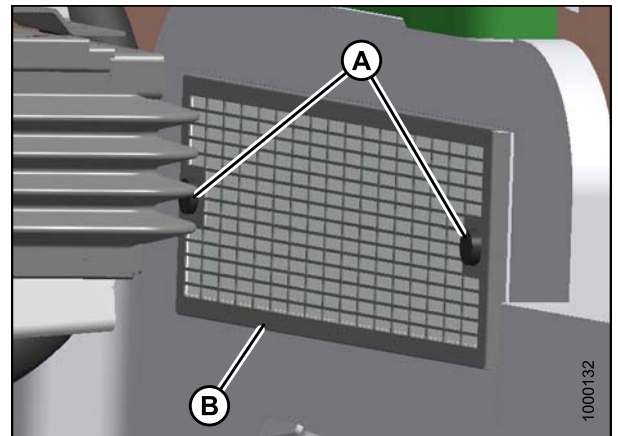

Figure 5.32: Return Air Filter

2. Separate the filter (B) from the cover (A).
3. Clean or replace the filter. If cleaning filter, refer to [Cleaning Return Air Cleaner/Filter, page 304](#).
4. Assemble the cleaner (B) and cover (A), and position on cab wall over opening.

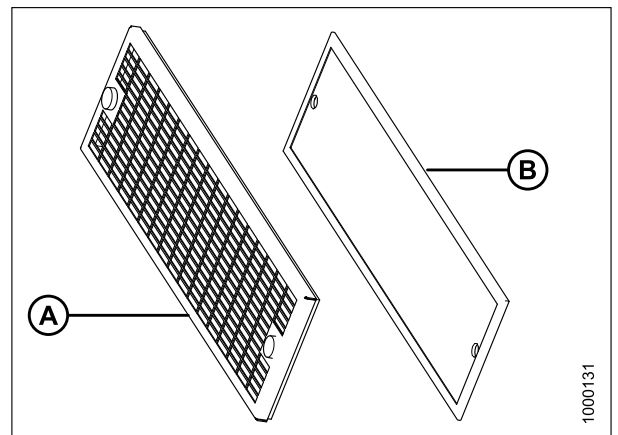

Figure 5.33: Return Air Filter

## MAINTENANCE AND SERVICING

- Secure filter assembly (B) to cab wall with knobs (A).

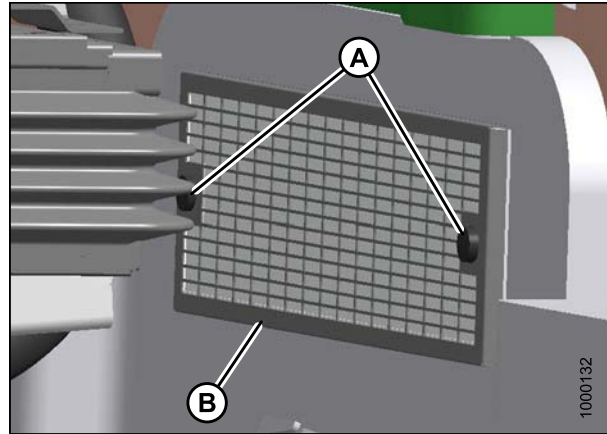

Figure 5.34: Return Air Filter

### *Cleaning Return Air Cleaner/Filter*

Clean the electrostatic filter as follows:

- Mix a solution of warm water and detergent in a suitable container so that the filter (B) can soak for a few minutes.
- Agitate to flush out the dirt.
- Rinse with clean water, and then dry with compressed air.
- Inspect filter for damage, separation, and holes. Replace if damaged.

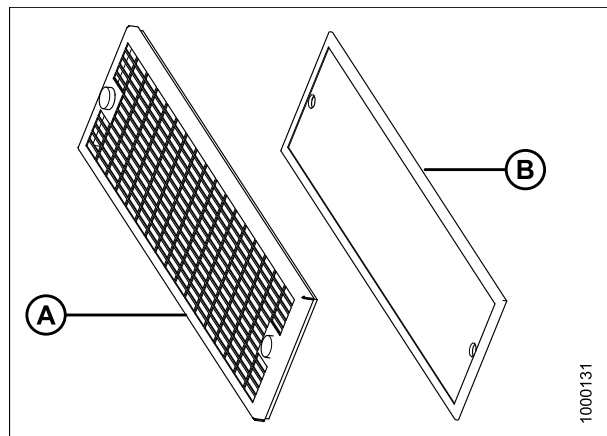

Figure 5.35: Return Air Filter

### 5.6.3 Air Conditioning Condenser

The air conditioning condenser should be cleaned daily with compressed air. More frequent cleaning may be necessary in severe conditions.

Cleaning the condenser can be done at the same time as the radiator, oil cooler, and charge air cooler. Refer to [5.8 Maintaining Engine Cooling Box, page 349](#).

### 5.6.4 Air Conditioning (A/C) Evaporator Core

The A/C evaporator should be checked annually for cleanliness. If the A/C system produces insufficient cooling, a possible cause is clogged evaporator fins. Fins will clog up from the side, opposite the blowers. The evaporator is located inside the heating air conditioning unit under the cab.

*Removing Air Conditioning (A/C) Cover*

**⚠ DANGER**

To avoid bodily injury or death from unexpected startup of the machine, always stop the engine and remove the key from the ignition before leaving the operator's seat for any reason.

1. Loosen the clamps (A) on the two drain hoses and pull the hoses off the A/C drain tubes.

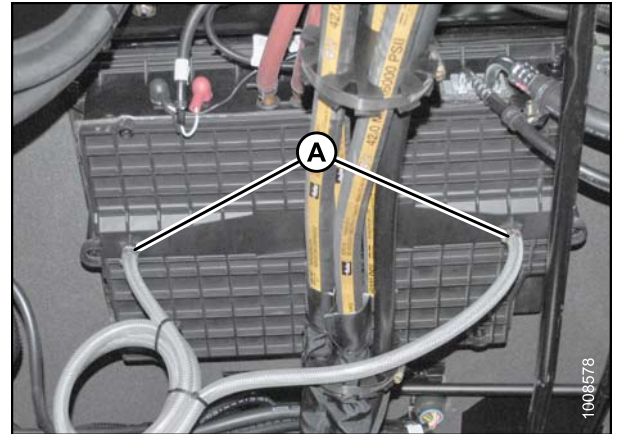

Figure 5.36: HVAC System

2. Remove the eight screws (A) that attach the cover (B) and remove the cover.

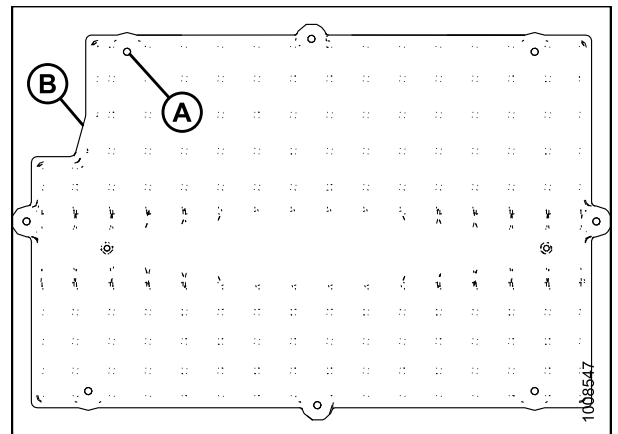

Figure 5.37: HVAC System

*Cleaning Air Conditioning (A/C) Evaporator Core*

**⚠ WARNING**

To avoid cuts from evaporator fins, do NOT use bare hands to brush away clogs.

1. Use a vacuum cleaner or compressed air to remove dirt from inside the unit.
2. Blow compressed air through the evaporator fins from the blower side (A) first as shown. Direct the air straight into the evaporator to prevent fin damage. A nozzle extension makes this procedure easier.
3. Repeat the previous step from the side (B) opposite the blowers.

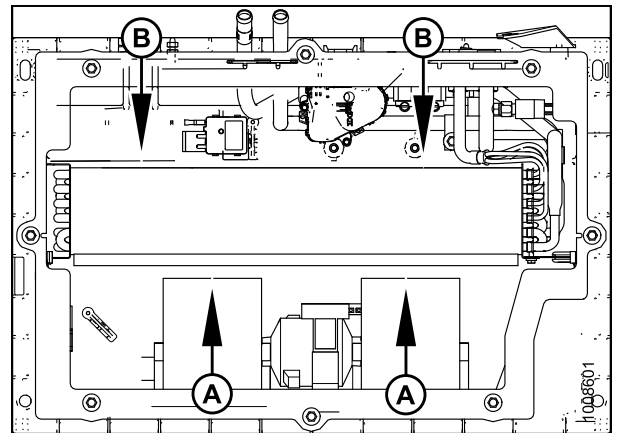

Figure 5.38: HVAC System

## MAINTENANCE AND SERVICING

4. If you cannot feel the compressed air blowing through the evaporator core, proceed as follows:
  - a. Protect the blower motor (A) from water.
  - b. Soak the evaporator core (B) with warm water using a low pressure hose. Let soak for several minutes.
  - c. Blow compressed air through the core from the blower side (C).
  - d. Repeat the soaking procedure until air blows through the evaporator freely.

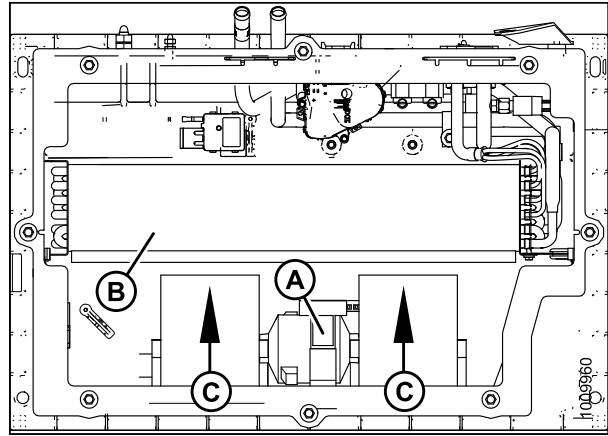

Figure 5.39: HVAC System

### Installing Air Conditioning (A/C) Cover

1. Straighten any bent fins.
2. Position cover (B) and attach with eight screws (A).

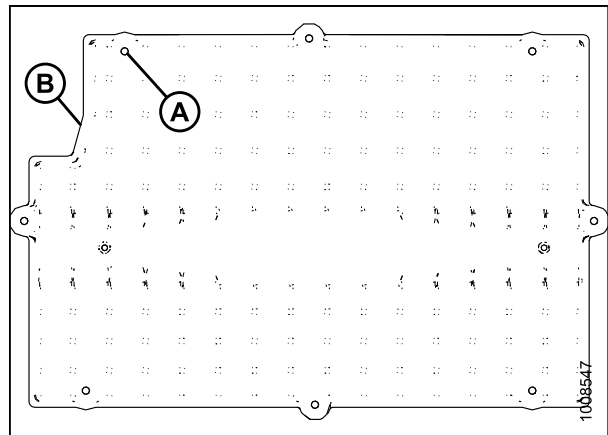

Figure 5.40: HVAC System

3. Reattach drain hoses to drain tubes and secure with hose clamps (A).

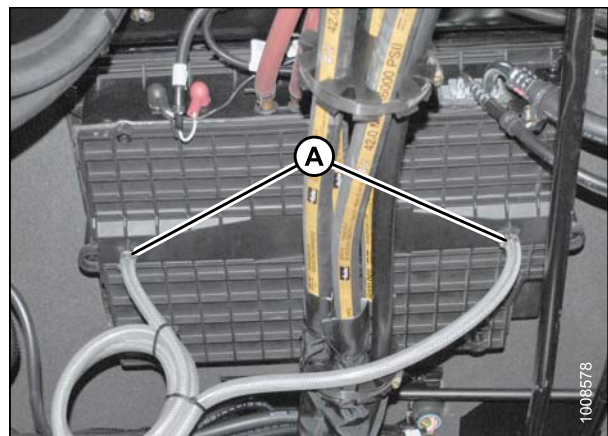

Figure 5.41: HVAC System

### 5.6.5 Air Conditioning (A/C) Compressor

The compressor is protected from excessively low suction and high discharge pressures by two switches that shut down the compressor to prevent damage to the system. These switches do not require regular servicing or maintenance. Contact your MacDon Dealer if you suspect a problem with the switches.

- The low pressure switch is normally closed when there is sufficient refrigerant in the system and the pressure is above 34 psi (234 kPa). The system remains pressurized at about 60–70 psi (414–483 kPa) with the compressor off. When the A/C system is turned on, the compressor starts because the system pressure is above 34 psi (234 kPa). As the system gets colder, the suction pressure (low side) drops. At 3.5–12.5 psi (24–86 kPa) (for 2014 and prior: 2–8 psi [14–55 kPa]), the switch opens and shuts down the compressor. When the pressure rises above 25 psi (172 kPa), the switch closes and the compressor restarts. The low pressure switch is located at the outlet of the evaporator (under cab in the A/C box).
- The high pressure switch is normally closed when there is sufficient refrigerant in the system. The system remains pressurized at about 60–70 psi (414–483 kPa) with the compressor off. If the pressure exceeds 360–380 psi (2482–2620 kPa) during operation, the valve opens. It will close when pressure falls below 220–280 psi (1517–1931 kPa). The high pressure switch is located on the receiver drier (right cab-forward frame rail, behind the fuse panel).

If the compressor cycles rapidly due to rapid pressure changes, the cab display module (CDM) displays a warning CHECK A/C SYSTEM. Contact your Dealer.

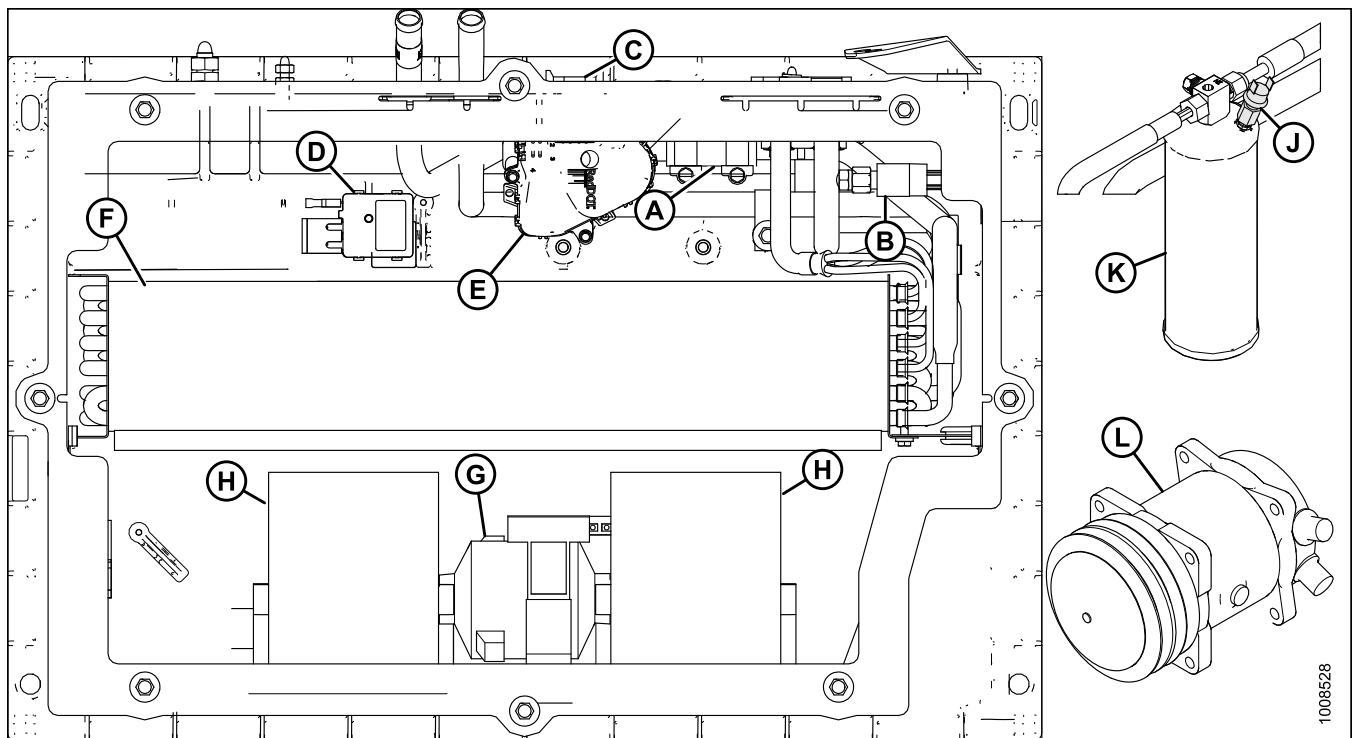

**Figure 5.42: HVAC System (MD #202957)**

- |                          |                         |                          |                 |
|--------------------------|-------------------------|--------------------------|-----------------|
| A - Expansion Valve      | B - Low Pressure Switch | C - Electrical Connector | D - Thermostat  |
| E - Heater Valve         | F - Evaporator Core     | G - Blower Motor         | H - Blower Fans |
| J - High Pressure Switch | K - Receiver Drier      | L - Compressor           |                 |

## MAINTENANCE AND SERVICING

### *Servicing the Air Conditioning Compressor*

Refer to [Replacing Air Conditioner \(A/C\) Compressor Belt, page 347](#) for belt replacement procedure.

See your MacDon Dealer for all other servicing procedures.



## 5.7 Engine

### CAUTION

- NEVER operate engine in a closed building. Proper ventilation is required to avoid exhaust gas hazards.
- Keep the engine clean. Straw and chaff on a hot engine are a fire hazard.
- NEVER use gasoline, naphtha, or any other volatile material for cleaning purposes. These materials are toxic and/or flammable.

### 5.7.1 General Engine Inspection

Engine inspection should be performed by your MacDon Dealer.

Refer to your engine manual for further information. (Owner's Manual QSB 4.5 and QSB 6.7 Engine Cummins #4021531 are supplied with your machine).

### 5.7.2 Turning the Engine Manually

To manually turn the engine with the flywheel, an access hole is provided on the left cab-forward side for a barring tool that is available from Cummins.

### DANGER

**To avoid bodily injury or death from unexpected startup of the machine, always stop the engine and remove the key from the ignition before leaving the operator's seat for any reason.**

1. Stop engine and remove ignition key.
2. Open the hood to the lowest position. Refer to [5.2.1 Opening Hood \(Lower Position\), page 284](#).
3. Open left cab-forward side platform. Refer to [5.3.1 Opening Platforms \(Standard Position\), page 287](#).

## MAINTENANCE AND SERVICING

4. Remove positive (red) cables (A) from battery posts first, then remove negative (black) cables (B) from both battery posts.

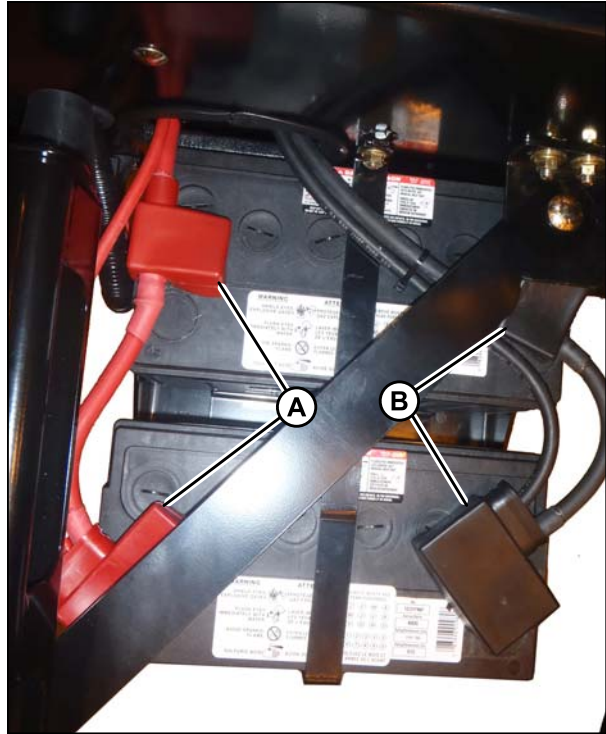

Figure 5.43: Battery Terminal Location

### IMPORTANT:

Clean the area around the plastic cap to ensure nothing falls into gearbox oil reservoir.

5. Clean the area around the plastic cap on access hole (A). Remove the cap.
6. Insert the barring tool (B) into the flywheel housing until it engages the ring gear.
7. Attach a 1/2 in. square drive ratchet or breaker bar and turn.
8. Remove barring tool (B) and clean oil from around access hole.
9. Clean plastic cap and reinstall in access hole (A) with silicone sealant.

### IMPORTANT:

BATTERY IS NEGATIVE GROUNDED. Always connect starter cable to the positive (+) terminal of battery and battery ground cable to negative (-) terminal of battery. Reversed polarity in battery or alternator may result in permanent damage to electrical system.

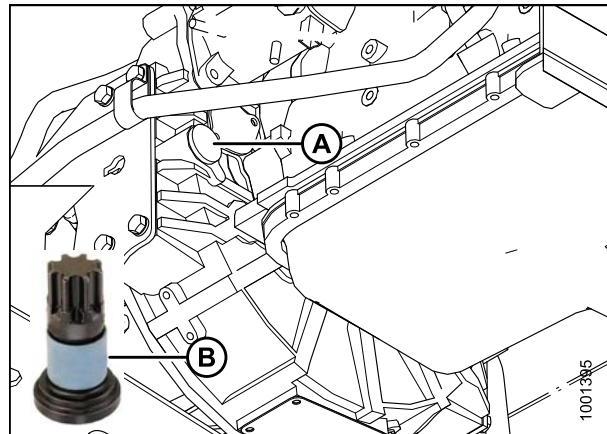

Figure 5.44: Access Hole Location for Barring Tool

## MAINTENANCE AND SERVICING

10. Attach negative (black) cables (B) to negative posts on batteries, and tighten clamps. Then attach positive (red) cables (A) to positive post on batteries and tighten clamps.
11. Position plastic covers onto clamps.
12. Close the hood. Refer to [5.2.2 Closing Hood \(Lower Position\)](#), page 285.
13. Close platform. Refer to [5.3.2 Closing Platforms \(Standard Position\)](#), page 288.

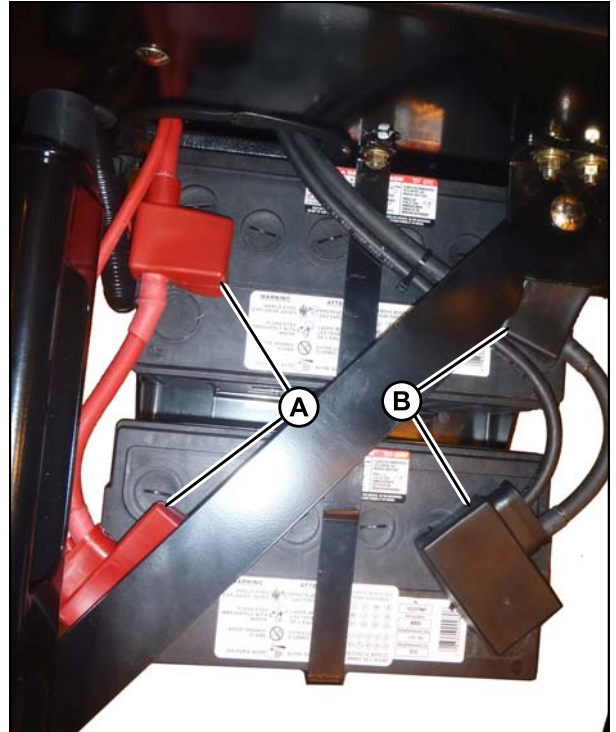

Figure 5.45: Battery Terminal Location

### 5.7.3 Checking Engine Oil Level

Check engine oil level daily (every 10 hours) and watch for any signs of leakage.

#### **DANGER**

To avoid bodily injury or death from unexpected startup of machine, always stop engine and remove key from ignition before leaving operator's seat for any reason.

#### **NOTE:**

During the break-in period, a higher than usual oil consumption should be considered normal.

1. Open the hood to the lowest position. Refer to [5.2.1 Opening Hood \(Lower Position\)](#), page 284.
2. Operate the engine at low idle and check for leaks at the filter and drain plug.
3. Stop the engine and remove the key. Wait about five minutes.

## MAINTENANCE AND SERVICING

4. Remove the dipstick (A) by turning it counterclockwise to unlock.
5. Wipe the dipstick clean and reinsert it into the engine.
6. Remove the dipstick again and check the oil level.

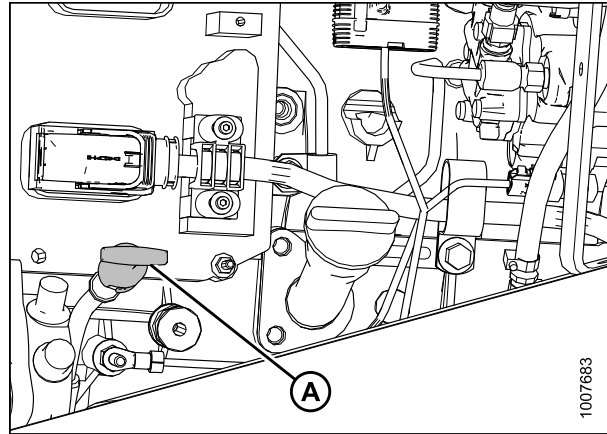

Figure 5.46: Engine Oil Level

7. Oil level should be maintained between LOW and HIGH. If level is below LOW mark, 2 US quarts (1.9 liters) will raise the level from LOW to HIGH.

**NOTE:**

If you need to add oil, refer to [Adding Engine Oil, page 313](#).

8. Replace dipstick and turn it clockwise to lock.
9. Close the hood. Refer to [5.2.2 Closing Hood \(Lower Position\), page 285](#).

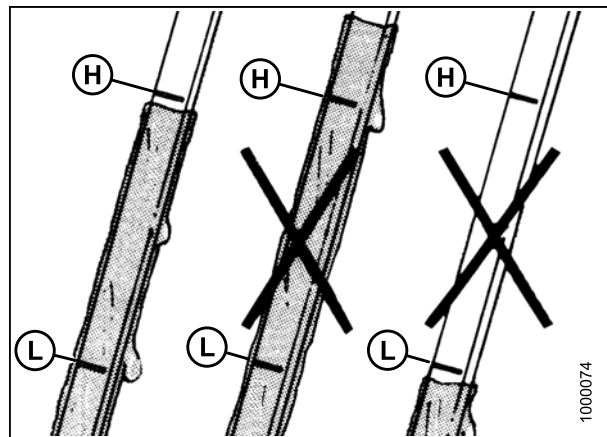

Figure 5.47: Engine Oil Level

### 5.7.4 Changing Engine Oil

#### *Draining Engine Oil*

#### **DANGER**

To avoid bodily injury or death from unexpected startup of the machine, always stop the engine and remove the key from the ignition before leaving the operator's seat for any reason.

**NOTE:**

The engine should be warm prior to changing the oil.

1. Stop the engine and remove the key.
2. Place a drain pan with a capacity of about 6 US gallons (24 liters) under the engine oil drain.

## MAINTENANCE AND SERVICING

3. Remove oil drain plug (A) and allow the oil to completely finish draining.
4. Replace drain plug (A).
5. Check the condition of the used oil. If either of the following is evident, have your Dealer correct the problem before starting the engine:
  - Thin black oil indicates fuel dilution
  - Milky discoloration indicates coolant dilution
6. Properly dispose of used oil.

### **IMPORTANT:**

Do **NOT** run engine without oil in the crankcase. Refer to [Adding Engine Oil, page 313](#).

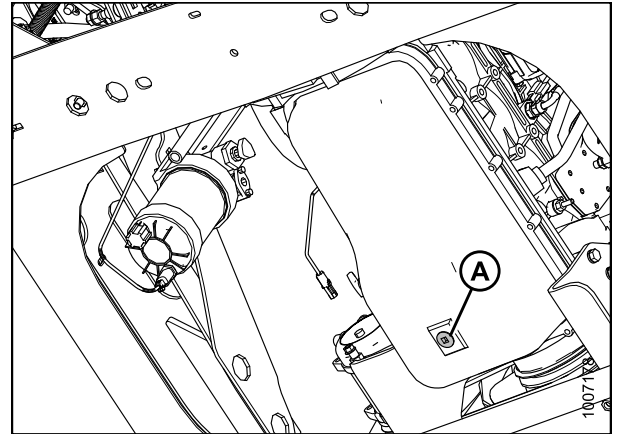

**Figure 5.48: Engine Oil Drain Plug**

### *Replacing Engine Oil Filter*

#### **NOTE:**

Replace oil filter each time engine oil is changed.

1. Open the hood. Refer to [5.2.1 Opening Hood \(Lower Position\), page 284](#).
2. Clean around the filter head (A).
3. Remove filter.
4. Clean gasket mating surface.
5. Apply a thin film of clean oil to the gasket on the new filter. Refer to [8.1.4 Filter Part Numbers, page 445](#) for recommended oil filter to use.
6. Screw the new filter onto the filter mount until the gasket contacts the filter head.
7. Tighten the filter an additional 1/2 to 3/4 turn by hand.

#### **IMPORTANT:**

Do **NOT** use a filter wrench to install the oil filter. Overtightening can damage the gasket and filter.

8. Properly dispose of used oil filter.

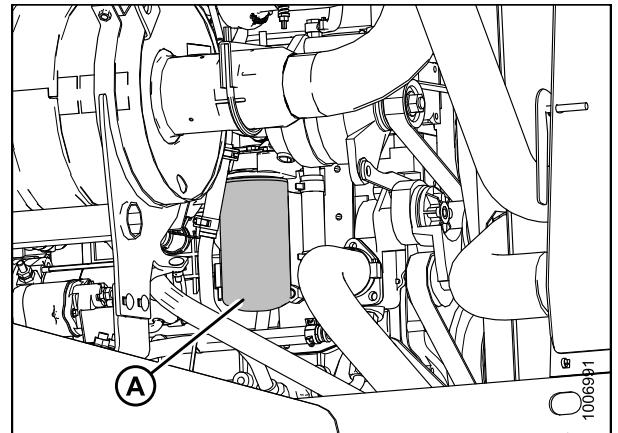

**Figure 5.49: Engine Oil Filter**

### *Adding Engine Oil*

#### **DANGER**

To avoid bodily injury or death from unexpected startup of machine, always stop engine and remove key from ignition before leaving operator's seat for any reason.

1. Stop the engine and remove the key. Wait about five minutes.
2. Open the hood. Refer to [5.2.1 Opening Hood \(Lower Position\), page 284](#).

## MAINTENANCE AND SERVICING

3. Remove filler cap (A) by turning it counterclockwise.
4. Carefully pour in the new oil. A funnel is recommended to avoid spillage. Refer to [8.1.3 Lubricants, Fluids, and System Capacities](#), page 444 for oil specifications.

### CAUTION

Do **NOT** fill above the **HIGH** mark.

5. Replace oil filler cap (A) and turn it clockwise until snug.
6. Check the oil level. Refer to [5.7.3 Checking Engine Oil Level](#), page 311.
7. Close the hood. Refer to [5.2.2 Closing Hood \(Lower Position\)](#), page 285.

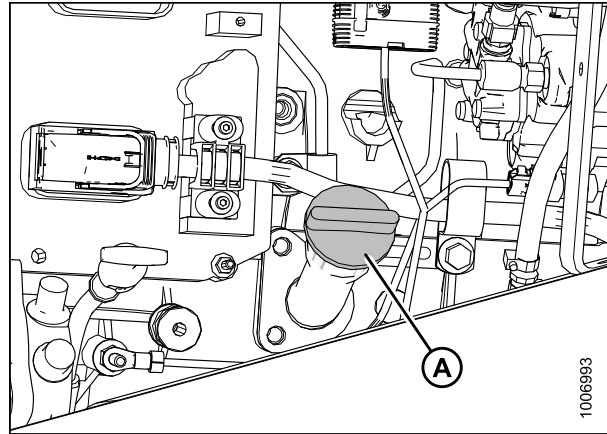

Figure 5.50: Oil Filler Cap

## 5.7.5 Air Intake System

### IMPORTANT:

Do **NOT** run engine with air cleaner disconnected or disassembled.

Engine intake air is drawn through a duct (A) from the cooling box that precleans the air and then through a dual element filter (B).

The air cleaner canister is equipped with an aspirator (C) that removes dust continuously from the air cleaner housing.

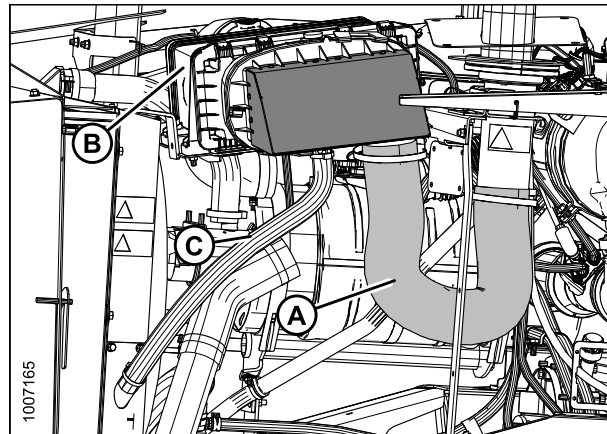

Figure 5.51: Air Intake System

## MAINTENANCE AND SERVICING

The air cleaner is also equipped with a restriction switch (A) that activates a warning display and tone on the cab display module (CDM) when the filter system requires servicing.

After servicing the filter, the restriction switch must be reset by pushing the button at the end of the switch.

### IMPORTANT:

- Do **NOT** run engine with air cleaner disconnected or disassembled.
- Over-servicing the filter element increases the risk of dirt being ingested by the engine and severely damaging the engine.
- Filter servicing should only be performed when the CDM indicates “ENGINE AIR FILTER” or at the specified interval. Refer to [5.12.1 Maintenance Schedule/Record, page 414](#).

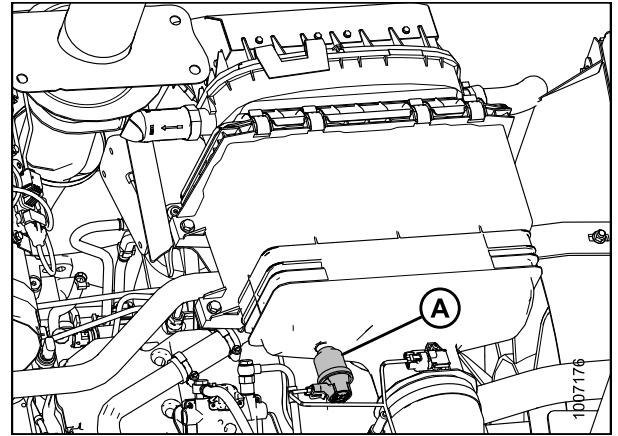

Figure 5.52: Air Restriction Indicator

### Removing Primary Air Filter

1. Open the hood. Refer to [5.2.1 Opening Hood \(Lower Position\), page 284](#).
2. Open the maintenance platform on right cab-forward side. Refer to [5.3.1 Opening Platforms \(Standard Position\), page 287](#).
3. Unlatch the clips (A) that secure the cover (B) and plenum (C) to the air cleaner housing (D).

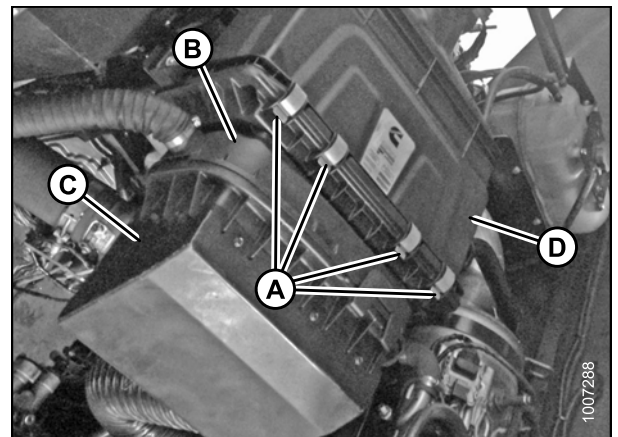

Figure 5.53: Air Cleaner Housing and Cover

## MAINTENANCE AND SERVICING

- Carefully move the cover (A) to dislodge it from the notches (B) at the bottom of the air cleaner housing (C).

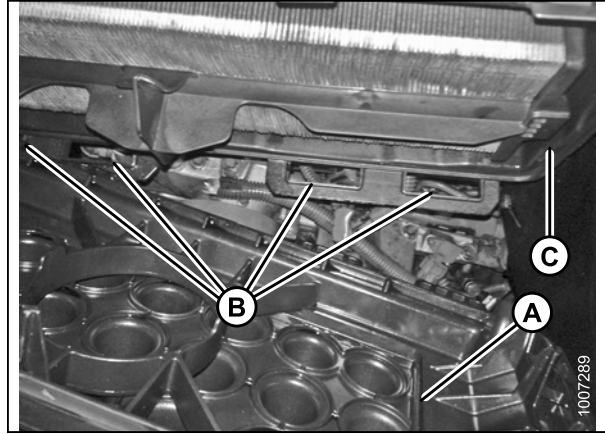

Figure 5.54: Air Cleaner Housing

- Check the aspirator duct opening (A) for obstructions or damage. Clean if necessary.
- Place cover (B) on windrower frame.

### NOTE:

Hoses can be left connected to the cover.

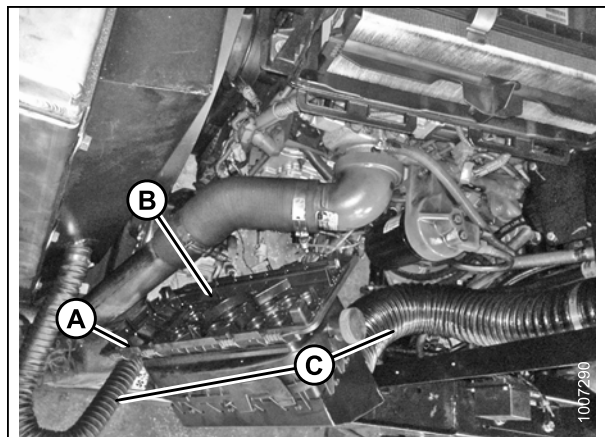

Figure 5.55: Air Cleaner

- Pull out the primary filter element (A).
- If necessary, also change the secondary filter. Refer to [Replacing the Secondary Air Filter, page 319](#).

### IMPORTANT:

- Do **NOT** remove the secondary filter unless it needs replacing. It must never be cleaned.
- Replace secondary filter annually or after every third primary filter change, even if it looks clean.
- If the secondary filter looks dirty, a further inspection will be required.
- Examine filter canister for cracks and replace as necessary.
- Ensure canister retaining latches are secure.

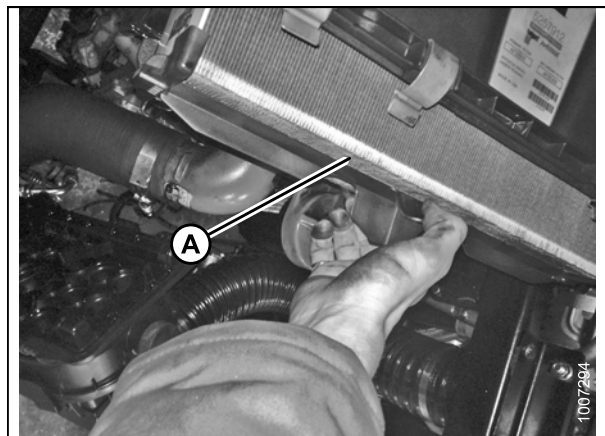

Figure 5.56: Air Cleaner Primary Filter



## MAINTENANCE AND SERVICING

### IMPORTANT:

Clean the inside of the housing and cover carefully. Dirt left in the air cleaner housing may be harmful to your engine.

- Use a clean, water-dampened cloth to wipe every surface clean.
- Check the housing visually to make sure it is clean before putting in a new element.
- Always clean the gasket sealing surfaces of the housing. An improper gasket seal is one of the most common causes of engine contamination.
- Make sure that all hardened dirt ridges are completely removed wherever filter gaskets contact the cleaner housing.

Check for uneven dirt patterns on your old element. Your old element is a valuable clue to potential dust leakage or gasket sealing problems.

- A pattern on the element clean side is a sign that the old element was not firmly sealed or that a dust leak exists.
- Make certain the cause of that leak is identified and rectified before replacing the element.
- Recheck to see if the sealing surface in the housing is clean.

### *Installing Primary Air Filter*

#### NOTE:

For primary air filter replacement part number. Refer to [8.1.4 Filter Part Numbers, page 445](#).

1. Insert new primary filter (A) into canister and push into place, ensuring that element is firmly seated in canister.

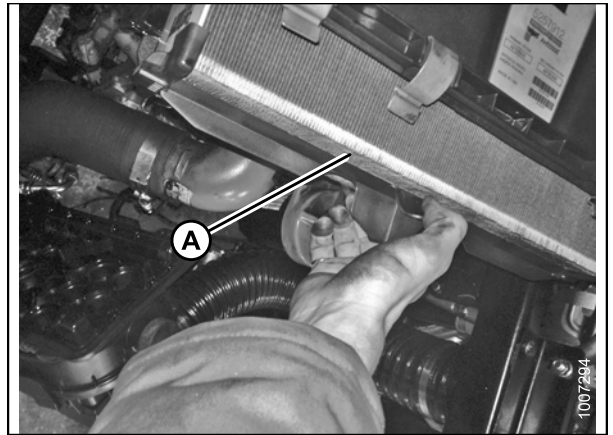

**Figure 5.57: Air Cleaner Primary Filter**

## MAINTENANCE AND SERVICING

2. Seat the tabs at the bottom of the cover (A) to the notches (B) at the bottom of the air cleaner housing (C).

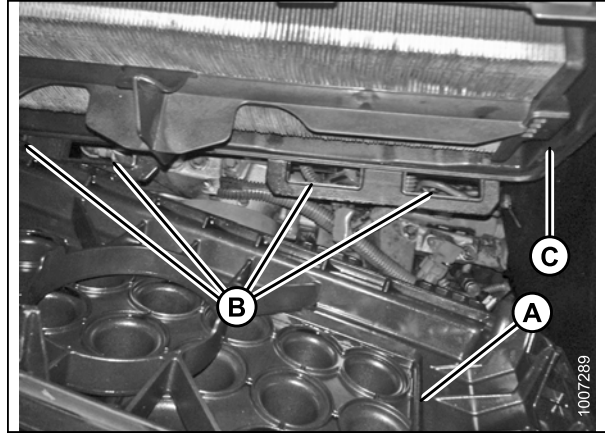

Figure 5.58: Air Cleaner

3. Secure cover (B) and plenum (C) to the air cleaner housing (D) using the four clips (A).

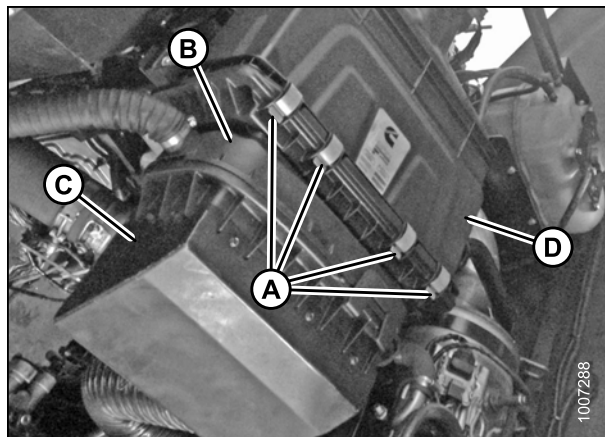

Figure 5.59: Air Cleaner Cover and Housing

4. Reset the restriction switch by pressing the button at the end of the switch (A).
5. Close the hood. Refer to [5.2.2 Closing Hood \(Lower Position\)](#), page 285.
6. Close the maintenance platform. Refer to [5.3.2 Closing Platforms \(Standard Position\)](#), page 288.

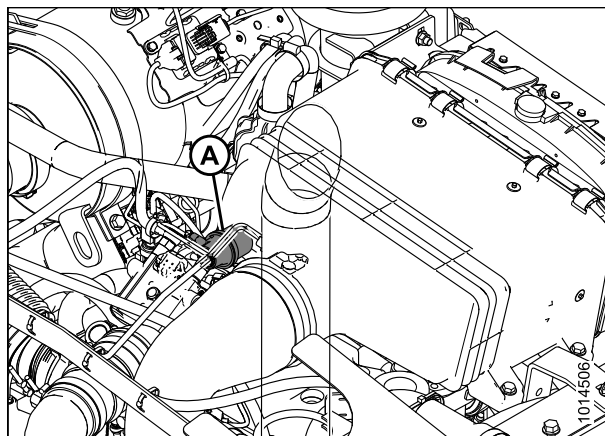

Figure 5.60: Air Cleaner Restriction Switch

## MAINTENANCE AND SERVICING

### *Cleaning the Engine Air Cleaner's Primary Filter*

The air cleaner's primary filter should be replaced after three cleanings or at the specified interval. The secondary element should be replaced every third time the primary element is changed. Refer to [5.12 Maintenance Schedule, page 414](#) for the required interval.

#### **IMPORTANT:**

- The secondary filter element should **NEVER** be cleaned, only replaced.
- **Air filter element cleaning is NOT recommended due to the possible degradation of the element material.** If cleaning is performed, there are several risks involved and the following steps should be followed. If any of the conditions described in these steps are found, the filter element **MUST** be replaced.
  1. Hold a bright light inside element and check carefully for holes. Vibration would quickly wear a hole in the filter.
  2. Check filter gasket for cracks, tears, or other signs of damage.
  3. Check element for oil or soot contamination.
  4. Check the secondary element for cleanliness. If there is visible dirt on the secondary element, replace both primary and secondary elements. Do **NOT** clean.
  5. If secondary element passes inspection, use compressed air not exceeding 40 psi (270 kPa) and a dry element cleaner gun to clean the primary element. Hold nozzle next to inner surface only and move up and down on pleats.

#### **NOTE:**

After three cleanings (or at the specified interval), replace the primary element.

6. Repeat inspection before installing.

### *Replacing the Secondary Air Filter*

For secondary filter replacement part number, refer to [8.1.4 Filter Part Numbers, page 445](#).

Replace the secondary filter annually or after every third primary filter change, even if it appears clean. If you are changing the secondary filter because it looks dirty, further inspection is required. Examine the filter canister for cracks and replace as necessary. Ensure the canister's retaining latches (B) are secure. Ensure filter sealing surfaces are soft, flexible, and sealing properly. Poor seal performance will allow debris through to the secondary filter.

#### **IMPORTANT:**

The secondary filter (A) should never be cleaned, only replaced. Do **NOT** remove the secondary filter unless it needs replacing.

## MAINTENANCE AND SERVICING

1. Remove the primary filter. Refer to [Removing Primary Air Filter, page 315](#).

### IMPORTANT:

When replacing secondary filter, reinsert new filter as soon as possible to prevent dirt and dust from entering the engine intake.

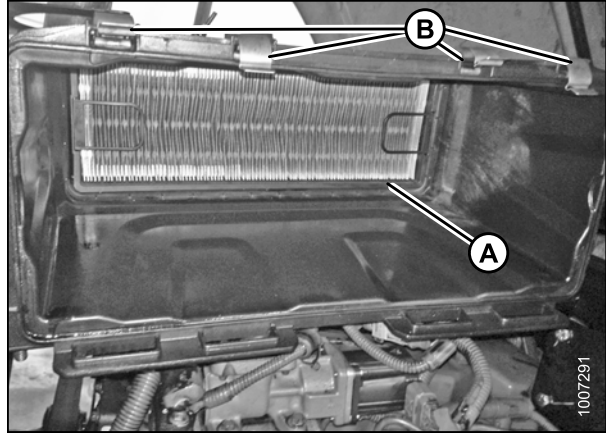

Figure 5.61: Secondary Air Filter

2. Pull handle (A) on each end of the secondary filter (B) until filter (B) is removed from the housing.

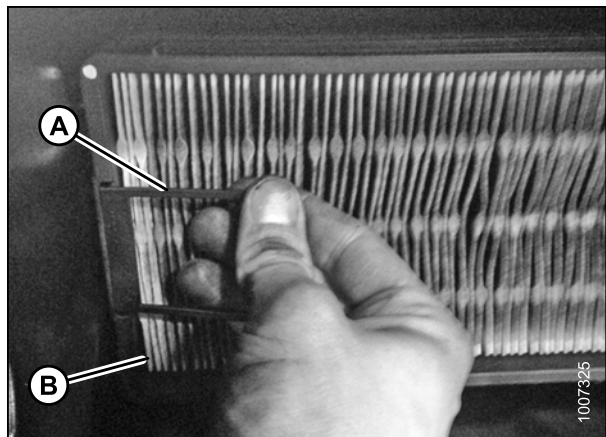

Figure 5.62: Secondary Air Filter

3. Insert new secondary filter (A) into the housing and push until filter is seated inside housing.
4. Install the primary filter. Refer to [Installing Primary Air Filter, page 317](#).

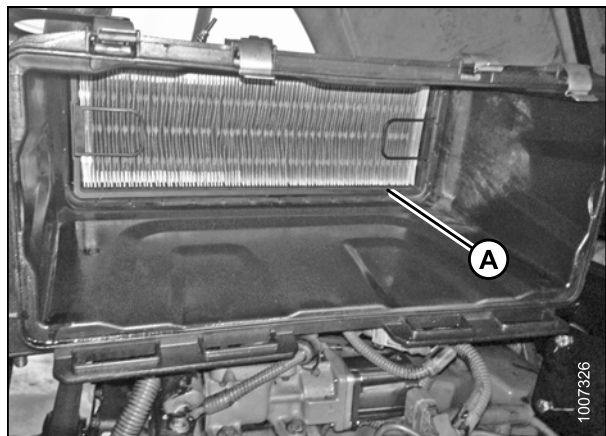

Figure 5.63: Secondary Air Filter

## 5.7.6 Charge Air Cooling

Charge air is routed through a cooler that is located in the cooling box (C), prior to entering the engine intake. The cooler should be cleaned daily with compressed air. Refer to [5.8 Maintaining Engine Cooling Box, page 349](#).

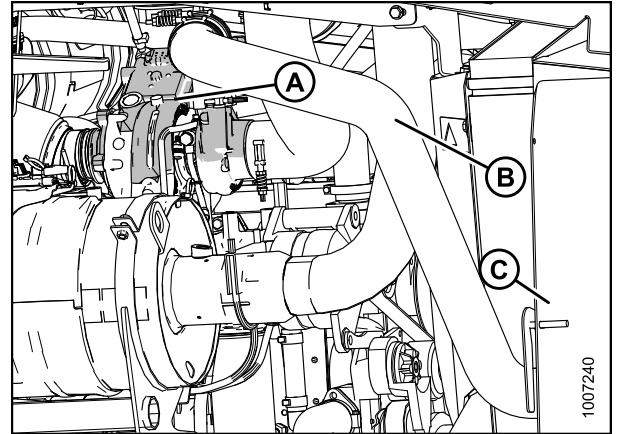

Figure 5.64: Engine Air Intake System

## 5.7.7 Fuel System

### Replacing Fuel Tank Vent Filter

The fuel tank is vented by a hose that is connected to the filler tube. The hose is connected to a filter that should be changed every year.

Replace the filter as follows:

### DANGER

To avoid bodily injury or death from unexpected startup of the machine, always stop the engine and remove the key from the ignition before leaving the operator's seat for any reason.

### WARNING

To avoid personal injury or death from explosion or fire, do NOT smoke or allow flame or sparks near windrower when servicing.

1. Stop the engine and remove the key.
2. Open the hood. Refer to [5.2.3 Opening Hood \(Highest Position\), page 285](#).
3. Open the left cab-forward side maintenance platform. Refer to [5.3.1 Opening Platforms \(Standard Position\), page 287](#).

## MAINTENANCE AND SERVICING

4. Locate filter (A) on vent line against hydraulic oil reservoir.
5. Release hose tension clamps (B) and slide away from filter. Pull hoses off filter.
6. Position new filter through hole in frame and attach top hose onto filter. The *IN* marking on the filter should face down.

### NOTE:

If filter has an arrow instead of an *IN* marking, arrow should point up.

7. Attach lower hose to filter and secure both hoses with tension clamps (B).
8. Close hood. Refer to [5.2.4 Closing Hood \(Highest Position\)](#), page 286.
9. Close the maintenance platform. Refer to [5.3.2 Closing Platforms \(Standard Position\)](#), page 288.

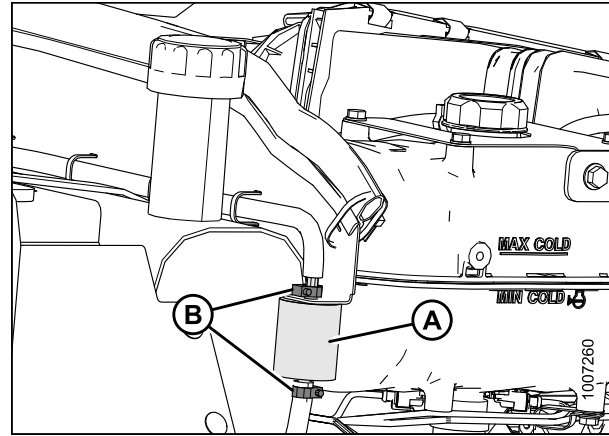

Figure 5.65: Fuel System

### Maintaining Fuel Filters

The windrower fuel system is equipped with primary (A) and secondary (B) screw-on cartridge type filters. The primary filter (A) is equipped with a separator that separates sediment and water from the fuel.

Refer to the following procedures:

- [Removing Primary Fuel Filter](#), page 322
- [Installing Primary Fuel Filter](#), page 323
- [Removing Secondary Fuel Filter](#), page 324
- [Installing Secondary Fuel Filter](#), page 325

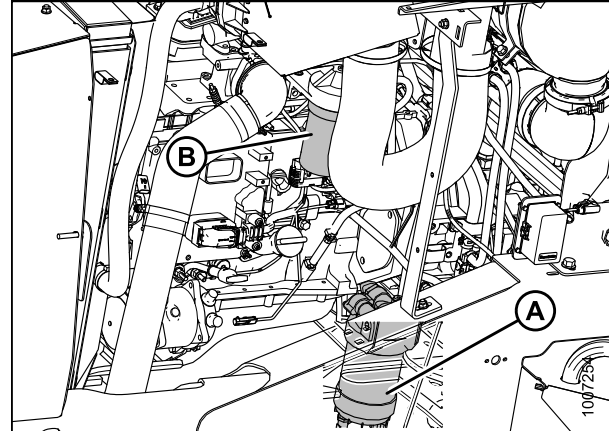

Figure 5.66: Fuel System Filters

### Removing Primary Fuel Filter

1. Stop the engine and remove the key.
2. Open the hood. Refer to [5.2.3 Opening Hood \(Highest Position\)](#), page 285.

## MAINTENANCE AND SERVICING

3. On the bottom of the fuel tank, locate the fuel supply valve (A) and move it to the closed position.

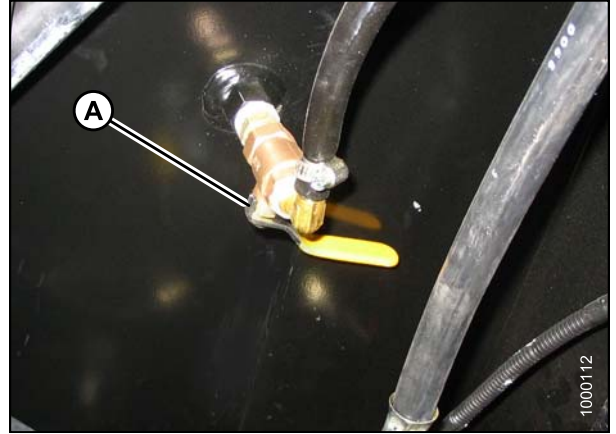

Figure 5.67: Fuel System

4. Locate the primary fuel filter (A) on the right cab-forward side of the windrower.

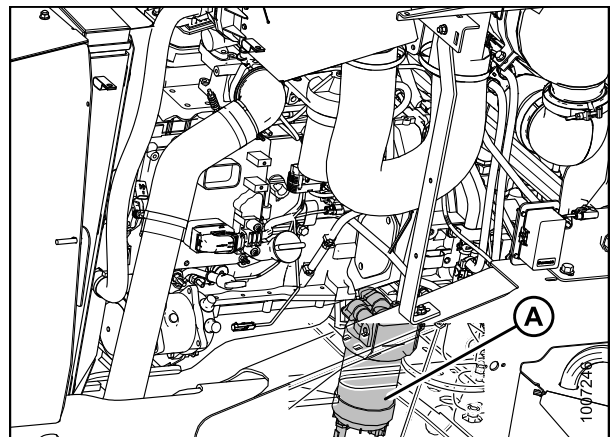

Figure 5.68: Fuel Filter Locations

5. Clean around the primary filter (A) head.
6. Disconnect the water in fuel (WIF) sensor (B) from bottom of filter.
7. Turn valve (C) by hand counterclockwise and drain filter into a container.
8. Remove filter (A) with a 1 in. (25.4 mm) wrench using the drive feature located on the bottom of the filter.
9. Clean gasket mating surface.

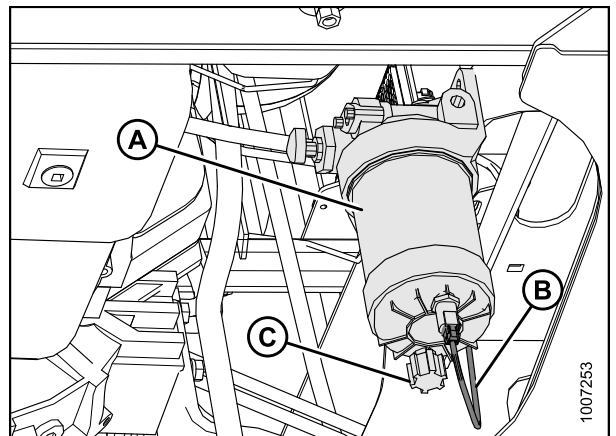

Figure 5.69: Fuel System

### Installing Primary Fuel Filter

#### **IMPORTANT:**

Do not pre-fill the pressure-side fuel filter with fuel, unless a clean side block-off plug is used. The system must be primed after the fuel filter is installed. Prefilling the pressure side of the fuel filter can result in debris entering the fuel system and damaging fuel system components.

## MAINTENANCE AND SERVICING

### IMPORTANT:

If available, pre-fill new filters, both pressure-side and suction-side, with clean fuel prior to assembly using the clean side block-off plug packed with the filter. Do not pour fuel directly in the center of the filter, since this will allow unfiltered fuel to enter the system and can cause damage to fuel system components.

### NOTE:

If replacing filter, refer to [8.1.4 Filter Part Numbers, page 445](#).

1. Lubricate the fuel filter o-ring with clean oil.
2. Screw the new filter (A) onto the filter mount until the gasket contacts the filter head.
3. Tighten the filter an additional 3/4 turn by hand. Use a 1 in. (25.4 mm) wrench and torque it to 28 ft lbf 38 (N m).
4. Reconnect water in fuel (WIF) sensor (B).

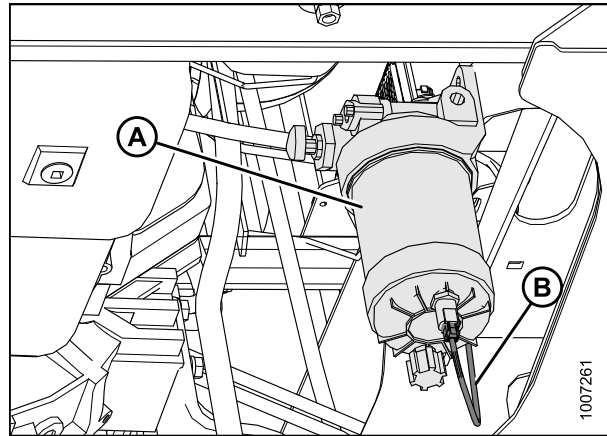

Figure 5.70: Fuel System

### Removing Secondary Fuel Filter

#### DANGER

To avoid bodily injury or death from unexpected startup of the machine, always stop the engine and remove the key from the ignition before leaving the operator's seat for any reason.

1. Stop the engine and remove the key.
2. Open the hood. Refer to [5.2.3 Opening Hood \(Highest Position\), page 285](#).
3. Clean around the secondary filter head (A).
4. Place a container under the filter to catch spilled fluid.
5. Remove filter (B) with a filter wrench.
6. Clean gasket mating surface.

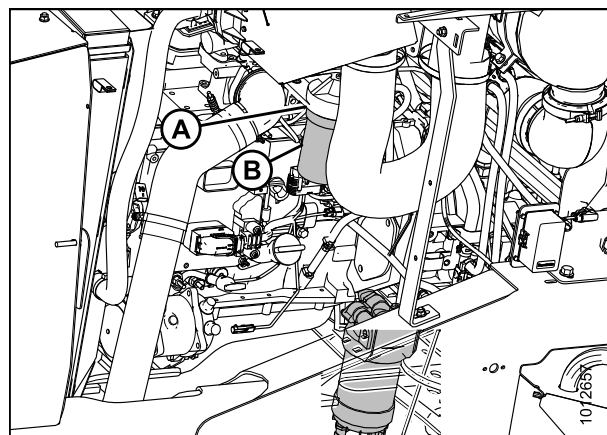

Figure 5.71: Fuel System



### Installing Secondary Fuel Filter

#### IMPORTANT:

Do **NOT** prefill filter with fuel. Prefilling can contaminate the fuel system.

#### NOTE:

If replacing filter, refer to [8.1.4 Filter Part Numbers, page 445](#).

1. Screw the new secondary filter (A) onto the filter mount until the gasket contacts the filter head.
2. Tighten the filter an additional 1/2 to 3/4 turn by hand.

#### IMPORTANT:

Do **NOT** use a filter wrench to install the filter. Overtightening can damage the gasket and filter.

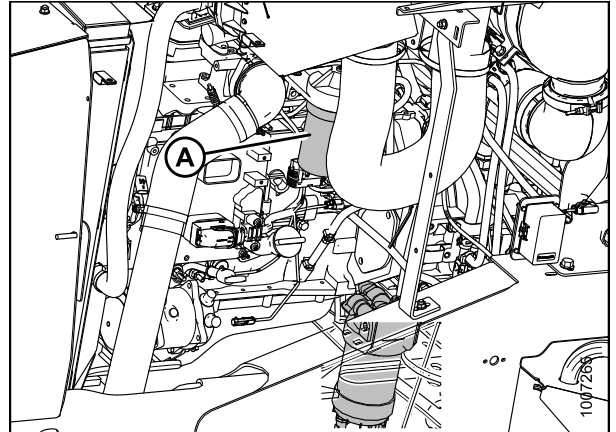

Figure 5.72: Fuel System

3. Open fuel valve (A) under fuel tank.
4. Prime the fuel system. Refer to [Priming Fuel System, page 329](#).

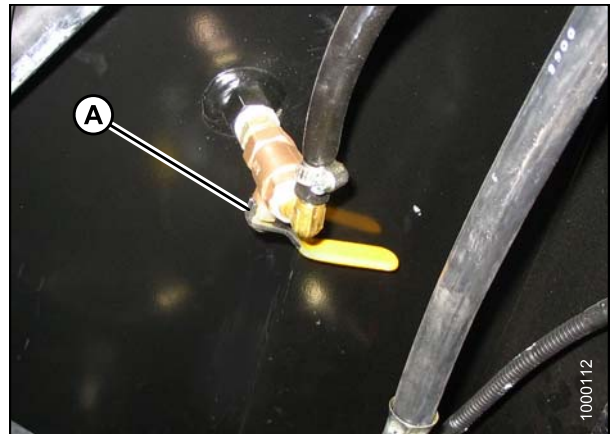

Figure 5.73: Bottom of Fuel Tank

### Draining Fuel Tank

Draining the fuel tank is necessary to remove old or contaminated fuel.

#### **WARNING**

- To avoid personal injury or death from explosion or fire, do **NOT** smoke or allow flame or sparks near fuel tank when refueling.
- **NEVER** refuel the windrower when the engine is hot or running.

#### **DANGER**

To avoid bodily injury or death from unexpected startup of the machine, always stop the engine and remove the key from the ignition before leaving the operator's seat for any reason.

## MAINTENANCE AND SERVICING

1. Stop the engine and remove the key.
2. Open the hood. Refer to [5.2.1 Opening Hood \(Lower Position\)](#), page 284.
3. Close fuel supply valve (A). Located on the bottom of the fuel tank.

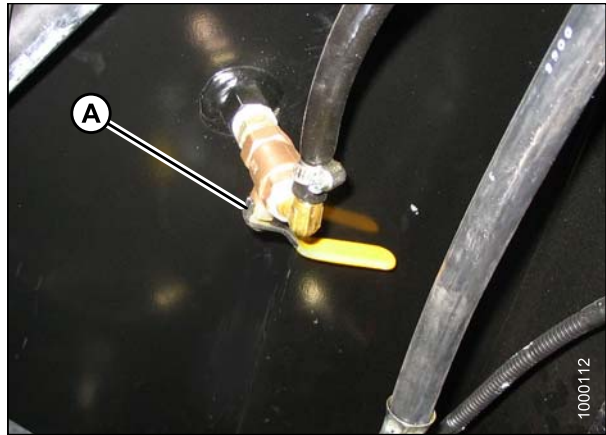

**Figure 5.74: Bottom of Fuel Tank**

4. Place a 5 US gallon (20 liter) drain pan under the fuel supply hose (A) at primary filter.
5. Loosen clamp (B) and pull fuel supply hose (A) off fitting.

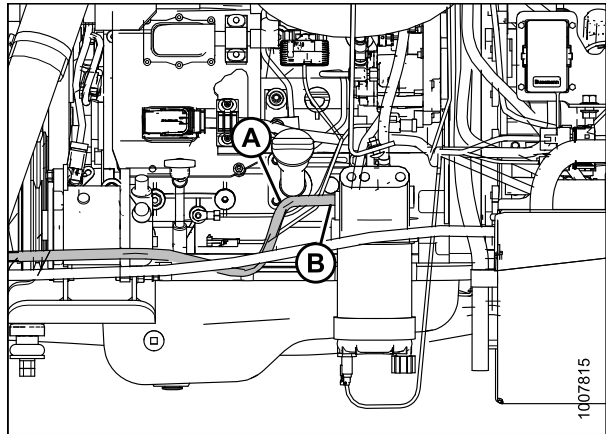

**Figure 5.75: Fuel System (View from Outside Frame)**

6. Route hose to drain pan and open valve (A) to drain tank.

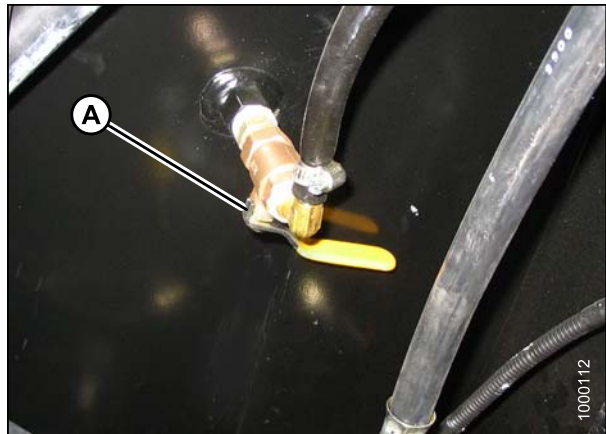

**Figure 5.76: Bottom of Fuel Tank**

## MAINTENANCE AND SERVICING

7. Add some clean fuel to tank to flush out any remaining contaminants.
8. Reattach fuel supply hose (A) to fitting. Install clamp (B) and tighten.

**NOTE:**

Do **NOT** refill the fuel tank if performing additional maintenance on fuel system. Refill it once work is completed. Refer to [Filling the Fuel Tank, page 327](#).

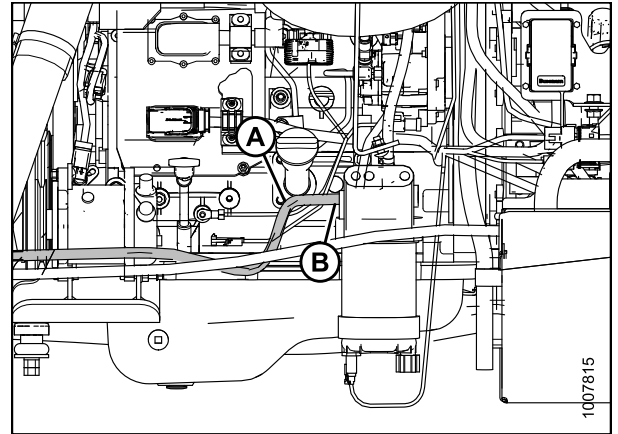

**Figure 5.77: Fuel System (View From Outside Frame)**

### *Filling the Fuel Tank*

Fill the fuel tank daily, preferably at the end of the day's operation to help prevent condensation in the tank.

**⚠ DANGER**

To avoid bodily injury or death from unexpected startup of the machine, always stop the engine and remove the key from the ignition before leaving the operator's seat for any reason.

**⚠ WARNING**

- To avoid personal injury or death from explosion or fire, do **NOT** smoke or allow flame or sparks near fuel tank when refueling.
- **NEVER** refuel the windrower when the engine is hot or running.

**⚠ CAUTION**

Do **NOT** allow tank to empty. Running out of fuel can cause air locks and/or contamination of the fuel system. Refer to [System Priming, page 329](#).

1. Stop windrower and remove key.
2. Stand on either platform to access the fuel tank filler pipe.

## MAINTENANCE AND SERVICING

3. Clean the area around filler cap (A).
4. Turn cap handle (B) counterclockwise until loose and then remove cap.
5. Fill tank with approved fuel. Refer to [8.1.3 Lubricants, Fluids, and System Capacities](#), page 444.

### IMPORTANT:

Do **NOT** fill tank completely—space is required for expansion. A filled tank could overflow if exposed to a rise in temperature, such as direct sunlight.

6. Replace fuel tank cap (A) and turn cap handle (B) clockwise until snug.

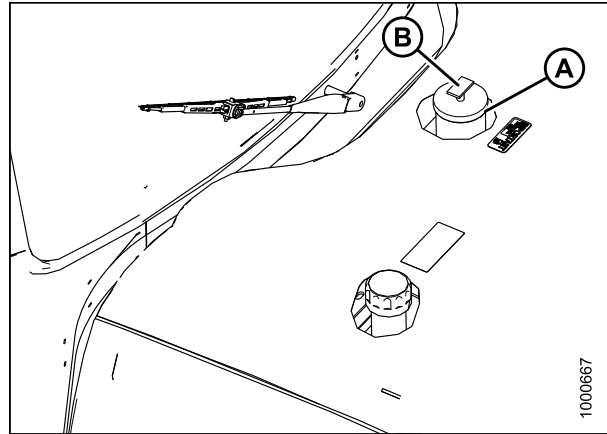

Figure 5.78: Fuel Filler Cap

### Fuel/Water Separator

A fuel water separator is incorporated into the primary fuel filter. The separator is equipped with a drain and with a sensor that detects water in the fuel and alerts the Operator on the cab display module (CDM). Drain the water and sediment from the separator daily or at any time the CDM Water In Fuel (WIF) light illuminates.

To remove water from the fuel system, refer to [Removing Water from Fuel System](#), page 328.

### Removing Water from Fuel System

Drain the water and sediment as follows from the separator daily, or at any time the cab display module (CDM) water in fuel (WIF) light illuminates.

### DANGER

To avoid bodily injury or death from unexpected startup of the machine, always stop the engine and remove the key from the ignition before leaving the operator's seat for any reason.

1. Stop the engine and remove the key.
2. Open the hood. Refer to [5.2.1 Opening Hood \(Lower Position\)](#), page 284.
3. Place a container under the filter (A) to catch spilled fluid.
4. Turn drain valve (B) by hand 1-1/2 to 2 turns counterclockwise until draining occurs.
5. Drain the filter sump of water and sediment until clear fuel is visible.
6. Turn the valve clockwise to close the drain.
7. Dispose of fluid safely.
8. Close the hood. Refer to [5.2.2 Closing Hood \(Lower Position\)](#), page 285.

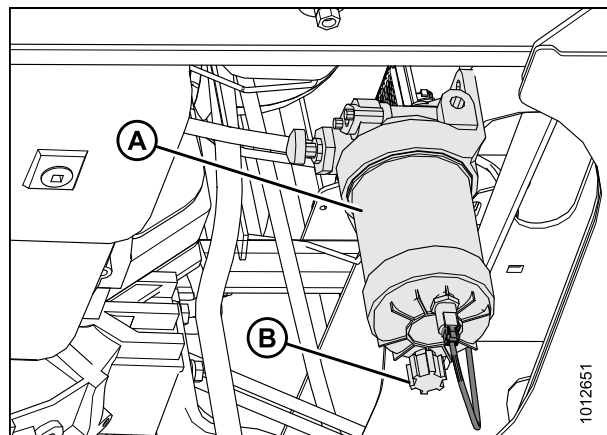

Figure 5.79: Fuel System

### System Priming

Controlled venting of air is provided at the injection pump through the fuel drain manifold. Small amounts of air introduced by changing filters or injection pump supply line will be vented automatically, if the fuel filters are changed in accordance with instructions.

#### **IMPORTANT:**

Bleeding the fuel system is **NOT** recommended or required. Manual priming will be required if:

- Fuel filter is replaced
- Injection pump is replaced
- High-pressure fuel lines are replaced
- Engine is run until fuel tank is empty

### Priming Fuel System

To prime the fuel system, follow these steps:

#### **⚠ DANGER**

To avoid bodily injury or death from unexpected startup of the machine, always stop the engine and remove the key from the ignition before leaving the operator's seat for any reason.

#### **⚠ WARNING**

The fuel pump high-pressure fuel lines and fuel rail contain extremely high pressure fuel. Never loosen any fittings. Personal injury and property damage can result.

1. Stop the engine and remove the key.
2. Open the hood to lowest position. Refer to [5.2.1 Opening Hood \(Lower Position\)](#), page 284.
3. Turn the priming knob (A) counterclockwise to unlock the plunger on the primary filter head.
4. Pump approximately 120 times to pressurize the fuel system.
5. Lock the plunger by turning knob (A) clockwise until snug.
6. Try starting engine. If engine does **NOT** start, repeat priming.
7. Close the hood. Refer to [5.2.2 Closing Hood \(Lower Position\)](#), page 285.

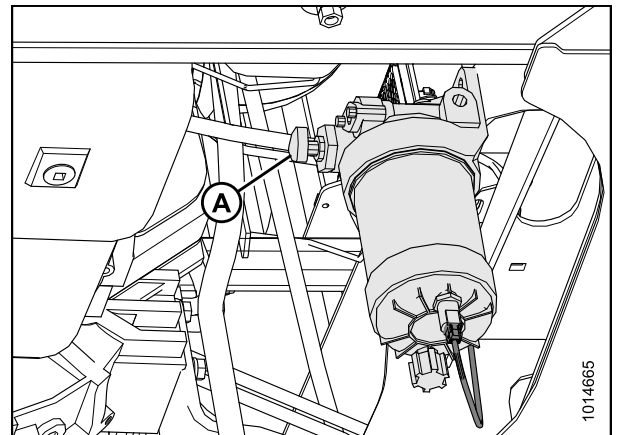

**Figure 5.80: Fuel System**

## 5.7.8 Diesel Exhaust Fluid (DEF) System

### *Draining the Diesel Exhaust Fluid (DEF) Tank*

It is necessary to drain the DEF tank when it is contaminated..

#### **⚠ DANGER**

**To avoid bodily injury or death from unexpected startup of the machine, always stop the engine and remove the key from the ignition before leaving the operator's seat for any reason.**

1. Stop the engine and remove the key.
2. Open the maintenance platform on right cab-forward side. Refer to [5.3.1 Opening Platforms \(Standard Position\)](#), page 287.
3. Place a drain pan under the DEF tank.

#### **IMPORTANT:**

Spilled DEF must be contained and absorbed by non-combustible absorbent material like sand and then shovelled to a suitable container for disposal. If spilled on tank or any surface of the vehicle, rinse thoroughly with water as DEF is corrosive.

#### **⚠ CAUTION**

**Avoid contact with eyes. In case of contact, rinse immediately with water for 15 minutes.**

4. Remove the drain plug (A) from under the tank (B) and drain.
5. Add some DEF to the tank (B) to flush out remaining contaminants.
6. Drain the DEF that was used to clean the tank.
7. Reinstall drain plug (A) to the tank (B).

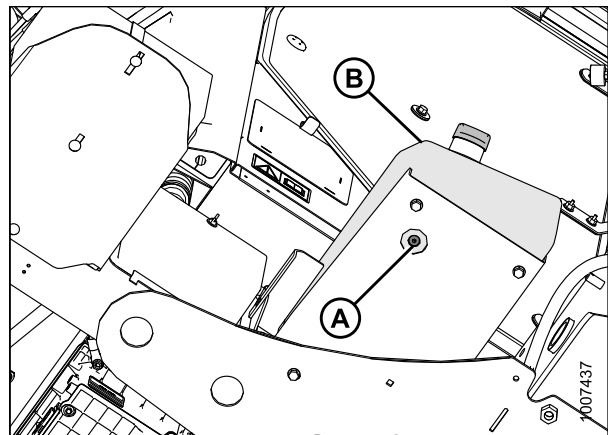

**Figure 5.81: View from Beneath Tank**

8. Refill DEF tank. Refer to [Refilling the Diesel Exhaust Fluid \(DEF\) Tank](#), page 331.
9. Close the maintenance platform. Refer to [5.3.2 Closing Platforms \(Standard Position\)](#), page 288.

### *Refilling the Diesel Exhaust Fluid (DEF) Tank*

To refill the DEF tank after draining, follow these steps:

#### **⚠ CAUTION**

**Avoid contact with eyes. In case of contact, flush eyes with water for a minimum of 15 minutes. Do NOT ingest DEF. If ingested, do NOT induce vomiting. Contact a physician immediately. Refer to Materials Safety Data Sheet (MSDS) for more information.**

Take the following precautions when handling DEF to prevent contamination:

- Avoid using funnels and containers that have been used with fuels or lubricants
- Use only distilled water to rinse the components that store or deliver DEF: tap water can contaminate DEF
- If distilled water is not available, use clean tap water then rinse components with DEF

1. Clean around filler cap (A).
2. Turn cap (A) counterclockwise until loose and remove cap.
3. Fill the tank with an approved DEF. Refer to [8.1.3 Lubricants, Fluids, and System Capacities, page 444](#).

#### **IMPORTANT:**

Spilled DEF must be contained and absorbed by a non-combustible absorbent material like sand and then shovelled to a suitable container for disposal. If spilled on tank or any surface of the vehicle, rinse thoroughly with water.

4. Replace filler cap (A) and turn clockwise until tight.
5. Close the maintenance platform. Refer to [5.3.2 Closing Platforms \(Standard Position\), page 288](#).

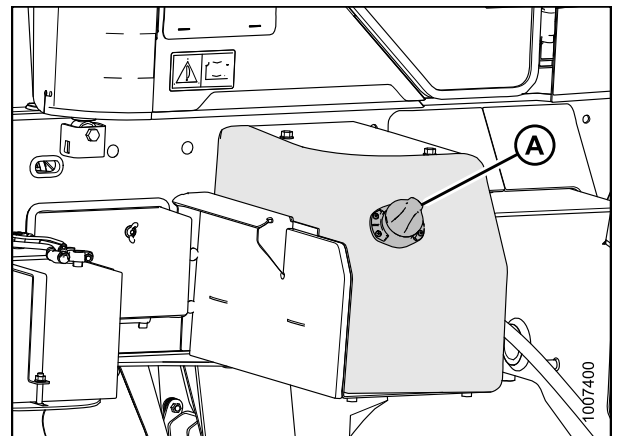

**Figure 5.82: DEF Tank**

### *Replacing the Diesel Exhaust Fluid (DEF) Vent Hose Filter*

The vent hose filter should be replaced every 2000 hours.

#### **⚠ DANGER**

**To avoid bodily injury or death from unexpected startup of the machine, always stop the engine and remove the key from the ignition before leaving the operator's seat for any reason.**

1. Stop the engine and remove the key.

## MAINTENANCE AND SERVICING

2. Locate the vent hose filter (A) behind the DEF tank.

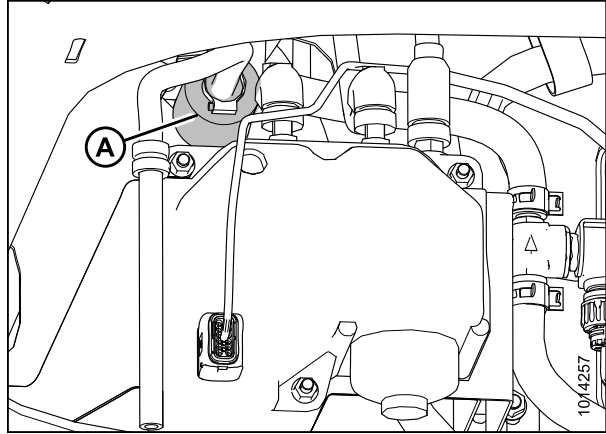

Figure 5.83: Rear of DEF Tank

3. Remove cable tie (A) securing vent hose filter to DEF suction hose.
4. Undo the two gear clamps (B) securing the vent hose filter to the hose heater (C).

**NOTE:**

Only one gear clamp is shown.

5. Pull the hose heater (C) from the vent hose filter.

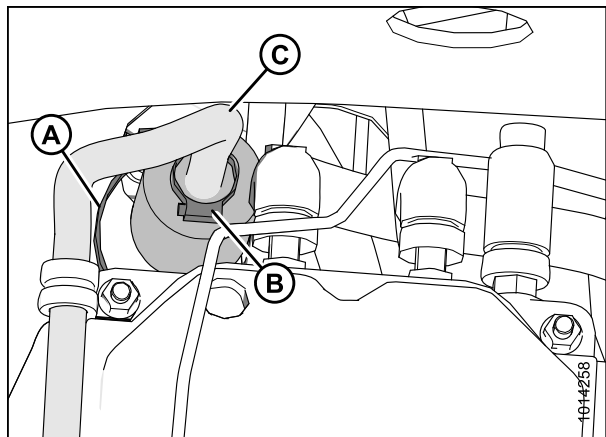

Figure 5.84: Vent Hose Filter (Behind DEF Tank)

6. Pull the vent hose filter (A) from the end of the other hose heater.

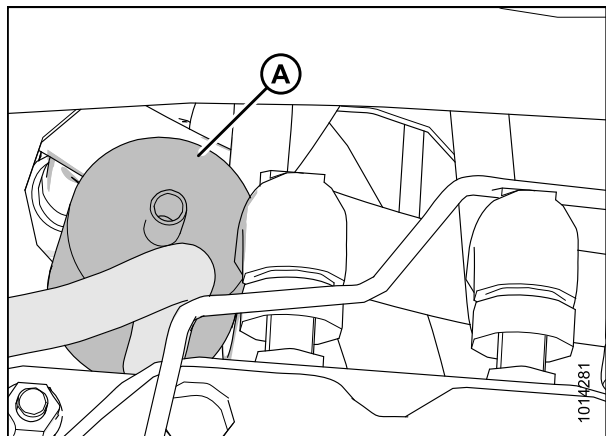
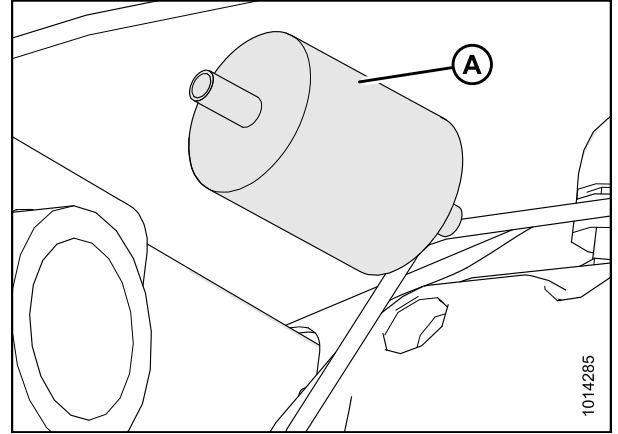

Figure 5.85: Vent Hose Filter



## MAINTENANCE AND SERVICING

7. Change the vent hose filter (A). Refer to [8.1.4 Filter Part Numbers, page 445](#).

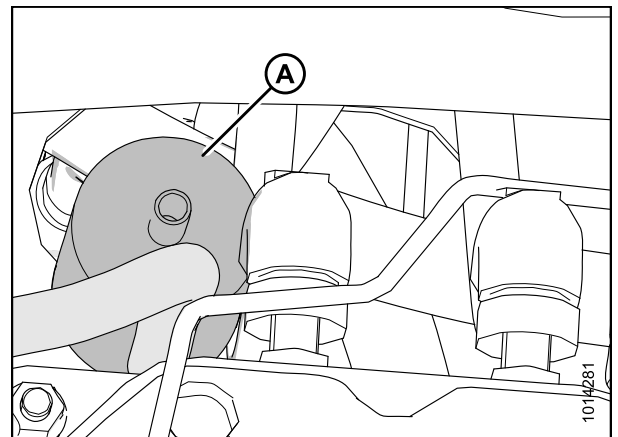

**Figure 5.86: Vent Hose Filter**

8. Install the new vent hose filter (A) on the hose heater and secure with gear clamp.

**NOTE:**

Ensure arrow on the vent hose filter (A) point towards the DEF tank.



**Figure 5.87: Vent Hose Filter**

9. Install hose heater (C) to the vent hose filter and secure with a gear clamp (B).
10. Secure vent hose filter to DEF suction hose using a cable tie (A).

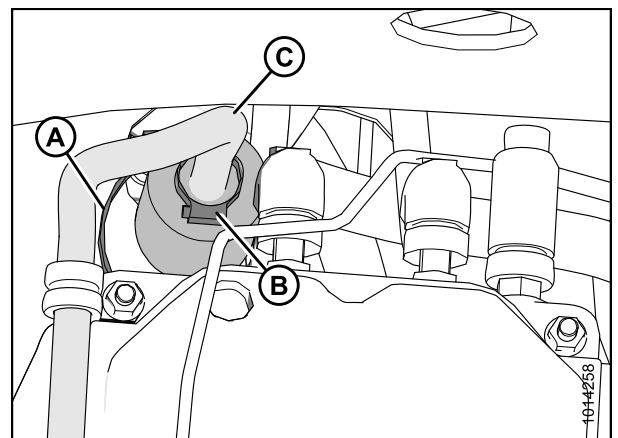

**Figure 5.88: Vent Hose Filter (Behind DEF Tank)**

### Supply Module Filter

The supply module filter is designed to prevent debris that may be suspended in the diesel exhaust fluid (DEF) from entering the dosing system. Debris can cause permanent damage and premature failure to the DEF supply module.

#### Checking the Supply Module Filter

1. Locate the aftertreatment diesel exhaust fluid (DEF) supply module (A) behind the DEF tank.

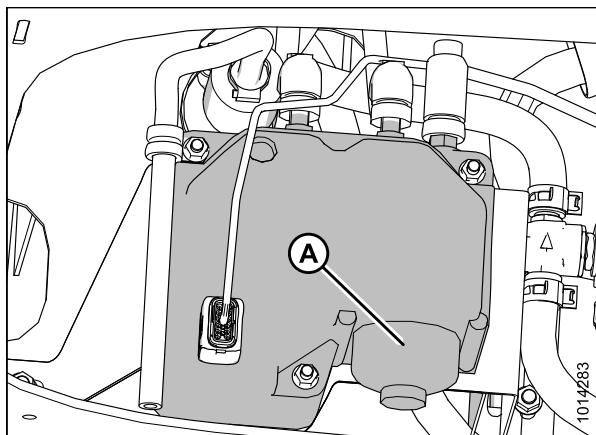
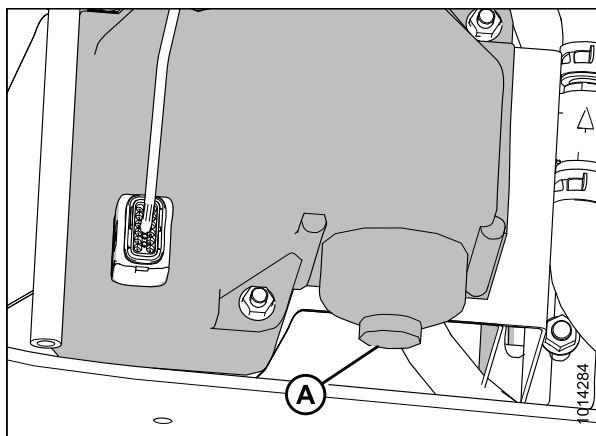

**Figure 5.89: DEF Supply Module**

2. Inspect the area around the seal and vent of the aftertreatment DEF supply module filter cap (A) for signs of leakage.

**NOTE:**

DEF fluid leaves a white deposit when dry. If there is evidence of leaking, remove the supply module filter, clean and inspect before replacing. For instructions, refer to [Cleaning and Inspecting the Supply Module Filter, page 335](#).



**Figure 5.90: DEF Supply Module Filter Cap**

#### Removing the Supply Module Filter

**⚠ WARNING**

Diesel Exhaust Fluid (DEF) contains urea. Do NOT get the substance in your eyes. In case of contact, immediately flush eyes with water for a minimum of 15 minutes. Do NOT swallow. In the event the DEF is ingested, contact physician immediately.

**⚠ WARNING**

Batteries can emit explosive gases. To reduce the possibility of personal injury, always ventilate the compartment before servicing the batteries. To reduce the possibility of arcing, remove the negative (-) battery cable first and attach the negative (-) battery cable last.

**⚠ WARNING**

The DEF line connecting the aftertreatment DEF supply module to the aftertreatment DEF dosing module is under low pressure and should not be disconnected while the engine is running or before the system has completed the purge process after engine shutdown. Disconnecting the DEF line while under low pressure could cause DEF to spray.

**⚠ WARNING**

Wear appropriate eye and face protection when using compressed air. Flying debris and dirt can cause personal injury.

**IMPORTANT:**

Do **NOT** disconnect the windrower batteries until the DEF dosing system has completed the purge cycle. Before beginning to remove and/or disconnect any components, wait at least five minutes after the key switch is turned OFF for the aftertreatment DEF dosing system to purge the DEF from the system. The purge cycle is an automatic process and does not require intervention to occur. The aftertreatment DEF supply module will create an audible pumping noise during the purging process.

**NOTE:**

DO **NOT** power wash or steam clean this unit. Use compressed air to remove any loose debris.

**NOTE:**

For filter part numbers. Refer to [8.1.4 Filter Part Numbers, page 445](#).

1. Disconnect the batteries. Refer to [Battery Main Disconnect Switch, page 355](#).
2. Place a catch basin under DEF filter cap to collect the remaining DEF in the filter housing.
3. Unscrew the filter cap (A).
4. Remove the aftertreatment DEF filter equalizing element (B).
5. Remove the old aftertreatment DEF supply module filter element (D).

**NOTE:**

A disposable service tool (C) is included with the filter to aid in filter removal. Use the appropriate end of the tool to remove filter. When inserting the tool, a click sound can be heard which indicates proper engagement with the filter.

6. Discard and replace the filter and equalizing element if removed from the aftertreatment dosing unit.

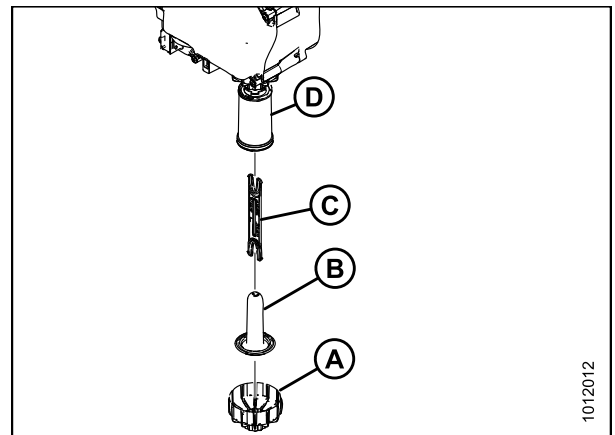

**Figure 5.91: DEF Supply Module Filter**

1012012

**Cleaning and Inspecting the Supply Module Filter**

**NOTE:**

If there is the possibility that contaminated diesel exhaust (DEF) has gone through the DEF dosing system, check the DEF filter prior to discarding the filter.

1. Check the diesel exhaust fluid (def) filter for evidence of contaminated DEF. Use visual and aroma characteristics of the filter to determine if contaminated fluid has passed through the dosing system.
2. Inspect the DEF filter for debris.
3. Discard the filter element and the equalizing element.

## MAINTENANCE AND SERVICING

4. Inspect the aftertreatment DEF supply module filter cap for cracks or holes.
5. Check the condition of the threads on the aftertreatment DEF supply module cap.
6. Replace the aftertreatment DEF supply module cap, if threads are damaged.
7. If cap threads are damaged, inspect the aftertreatment DEF supply module threads.
8. Replace the entire aftertreatment DEF supply module, if threads of aftertreatment DEF supply module are damaged.
9. Clean the aftertreatment DEF supply module cap and threads on the supply module with warm water and clean cloth.

### Installing the Supply Module Filter

1. Slide the diesel exhaust fluid (DEF) filter equalizing element (A) into the DEF filter cartridge (B).
2. Insert the assembly into the aftertreatment DEF dosing unit (C).
3. Install cap (D) and torque to 15 ft·lbf (20 N·m).

#### NOTE:

The aftertreatment DEF dosing system will not prime until the correct Selective Catalytic Reduction (SCR) temperatures are reached. To verify that there are no DEF leaks, test drive the windrower for a minimum of 15 minutes to get the SCR system up to temperature.

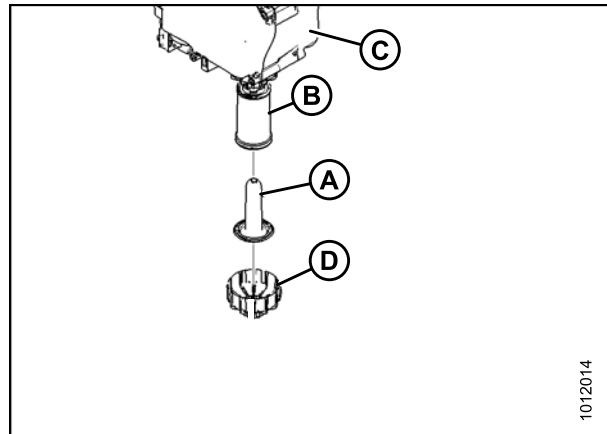

Figure 5.92: DEF Supply Module Filter

### WARNING

**Batteries can emit explosive gases. To reduce the possibility of personal injury, always ventilate the compartment before servicing the batteries. To reduce the possibility of arcing, remove the negative (-) battery cable first and attach the negative (-) battery cable last.**

4. Connect the batteries. Refer to [Connecting Batteries, page 361](#).
5. Operate the engine and check for leaks.

## 5.7.9 Engine Cooling System

The engine cooling system is designed to maintain the engine operating temperature within the specified operating range.

**NOTE:**

Antifreeze is essential in any climate. It broadens the operating temperature range by lowering the coolant freezing point and by raising its boiling point. Antifreeze also contains rust inhibitors and other additives to prolong engine life.

**IMPORTANT:**

If antifreeze strength is not adequate, do **NOT** drain cooling system to protect against freezing. System may not drain completely and damage from freezing could still result.

Refer to [8.1 Recommended Fuel, Fluids, and Lubricants, page 443](#) for detailed information.

### Checking Coolant Level



**DANGER**

To avoid bodily injury or death from unexpected startup of the machine, always stop the engine and remove the key from the ignition before leaving the operator's seat for any reason.

Check coolant level in the pressurized coolant tank (A) daily.

**NOTE:**

Ensure the engine has cooled down prior to checking. The tank has a maximum and a minimum cold line marker, coolant level should be between these lines.

1. Stop the engine and remove the key.
2. Open the hood. Refer to [5.2.3 Opening Hood \(Highest Position\), page 285](#).
3. Open the platform. Refer to [5.3.1 Opening Platforms \(Standard Position\), page 287](#).

**NOTE:**

To view coolant capacities, refer to [8.1 Recommended Fuel, Fluids, and Lubricants, page 443](#).

4. Close the platform. Refer to [5.3.2 Closing Platforms \(Standard Position\), page 288](#).
5. Close the hood. Refer to [5.2.4 Closing Hood \(Highest Position\), page 286](#).

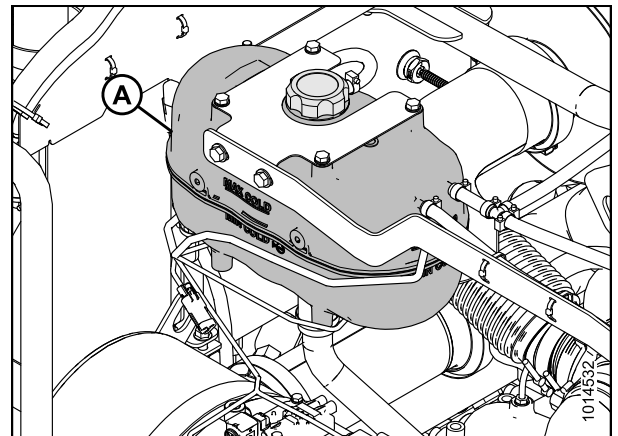

Figure 5.93: Engine Cooling System

### Checking Engine Coolant Strength

Check the anti-freeze in the pressurized coolant tank with a tester every year, preferably before off-season storage.

#### CAUTION

To avoid personal injury from hot coolant, do NOT turn pressurized coolant tank cap until engine cools.

1. Open the hood. Refer to [5.2.3 Opening Hood \(Highest Position\)](#), page 285.
2. Open the platform. Refer to [5.3.1 Opening Platforms \(Standard Position\)](#), page 287.
3. Remove the pressurized coolant tank cap (A).

#### IMPORTANT:

Turn the cap (A) counterclockwise to the first notch to relieve pressure before removing cap completely.

4. Check the coolant in the pressurized coolant tank using an antifreeze tester. Tester should indicate protection to temperatures of -30°F (-34°C).
5. Inspect the pressurized coolant tank cap before reinstalling. Refer to [Inspecting Pressurized Coolant Tank Cap](#), page 338.
6. Replace pressurized coolant tank cap (A).
7. Close the platform. Refer to [5.3.2 Closing Platforms \(Standard Position\)](#), page 288.
8. Close the hood. Refer to [5.2.4 Closing Hood \(Highest Position\)](#), page 286.

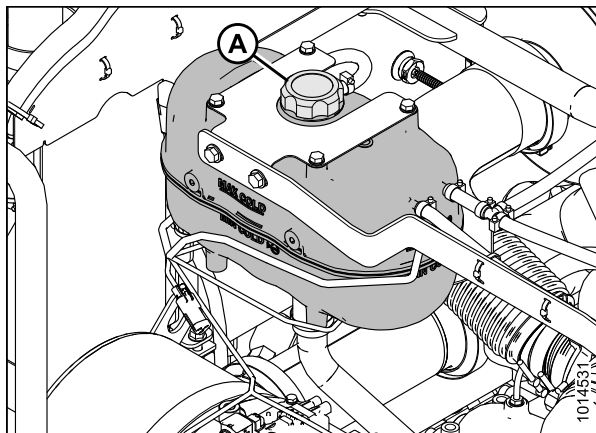

Figure 5.94: Engine Cooling System

### Inspecting Pressurized Coolant Tank Cap

The pressurized coolant tank cap must fit tightly and the cap gasket must be in good condition to maintain the 14–18 psi (97–124 kPa) pressure in the cooling system.

#### CAUTION

To avoid personal injury from hot coolant, do NOT turn pressurized coolant tank cap until engine cools.

1. Open the hood. Refer to [5.2.3 Opening Hood \(Highest Position\)](#), page 285.
2. Open the platform. Refer to [5.3.1 Opening Platforms \(Standard Position\)](#), page 287.

## MAINTENANCE AND SERVICING

3. Turn the cap (A) counterclockwise to the first notch to relieve pressure before removing cap completely.
4. Turn the cap (A) again and remove.
5. Check the gasket for cracks or deterioration and replace the cap if necessary.
6. Check that the spring in the cap moves freely.
7. Replace the cap if spring is stuck.
8. Close the platform. Refer to [5.3.2 Closing Platforms \(Standard Position\)](#), page 288.
9. Close the hood. Refer to [5.2.4 Closing Hood \(Highest Position\)](#), page 286.

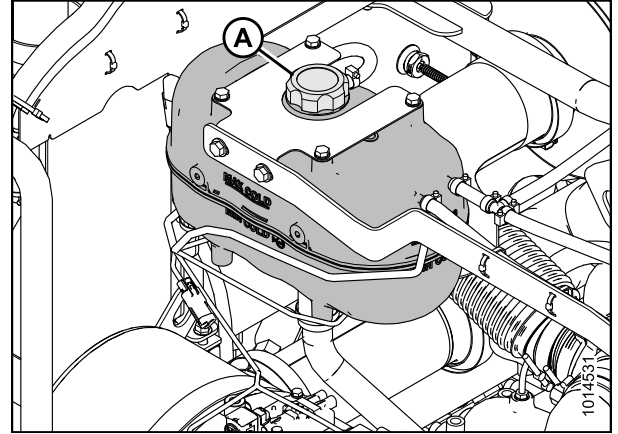

Figure 5.95: Engine Cooling System

### Changing Coolant

Coolant should be drained and the system flushed and filled with new coolant every **2000 hours or 2 years**.

Refer to the following procedures:

- [Draining Coolant](#), page 339
- [Adding Coolant](#), page 341

### Draining Coolant

#### **DANGER**

To avoid bodily injury or death from unexpected startup of the machine, always stop the engine and remove the key from the ignition before leaving the operator's seat for any reason.

#### **CAUTION**

To avoid personal injury from hot coolant, do NOT turn pressurized coolant tank cap until engine cools.

1. Stop the engine and remove the key. Let the engine cool.
2. Open the hood. Refer to [5.2.3 Opening Hood \(Highest Position\)](#), page 285.
3. Open the platform. Refer to [5.3.1 Opening Platforms \(Standard Position\)](#), page 287.
4. Turn the pressurized coolant tank cap (A) to the first notch to relieve pressure before removing cap completely.

#### **IMPORTANT:**

Place a drain pan (about 8 US gallons [30 liters]) under the engine and radiator, and use a deflector or hose to prevent coolant running onto frame.

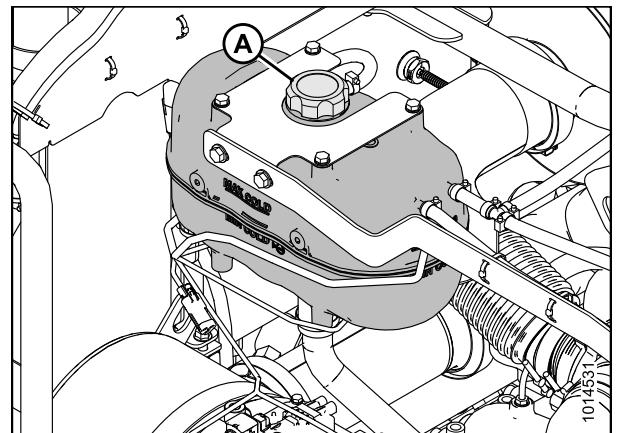
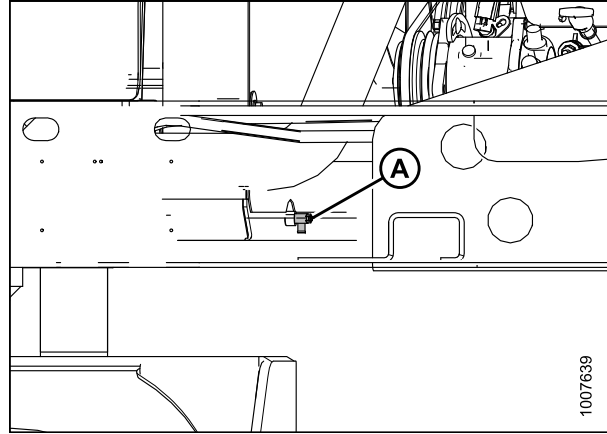

Figure 5.96: Coolant Recovery Tank

## MAINTENANCE AND SERVICING

- Remove the pressurized coolant tank cap and open radiator drain valve (A), located at the bottom of the engine side of the radiator lower tank. (Part of the lower left frame made transparent to show radiator drain valve location.)



**Figure 5.97: Radiator Drain Valve**

- Close the heater shut-off valve and disconnect hose on heater side of valve.
- Open valve to drain the block.
- When system is drained, reattach hose on valve.

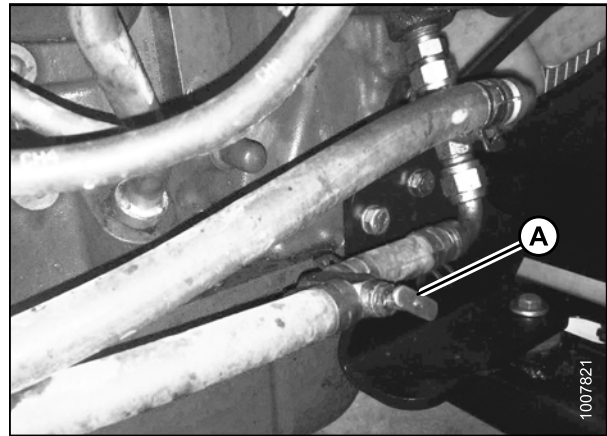

**Figure 5.98: Heater Shut-Off Valve**

- Close radiator drain valve (A) at the bottom of the engine side of the radiator lower tank. (Part of the lower left frame made transparent to show radiator drain valve location.)
- Fill system with clean water through the pressurized coolant tank and replace pressurized coolant tank cap.

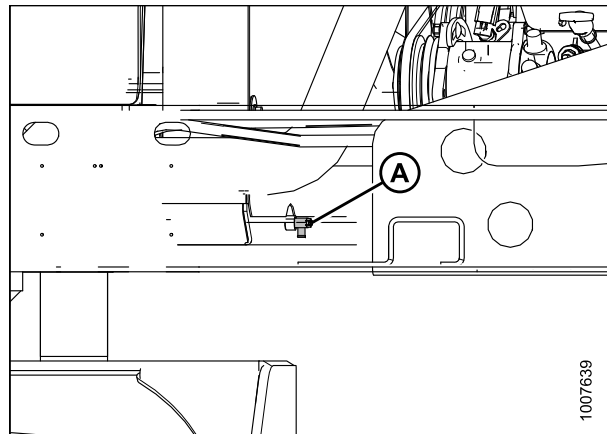

**Figure 5.99: Radiator Drain Valve**



## MAINTENANCE AND SERVICING

11. Open heater shut-off valve (A).
12. Start engine and turn temperature control knob to HIGH. Run engine until normal operating temperature is reached.
13. Stop the engine and drain water out before rust or sediment settles. Repeat coolant removal procedure.
14. Close drain valves and fill system with a solution of clean water and a heavy duty radiator cleaner. Follow instructions provided with cleaner.
15. After using the cleaner solution, flush system with clean water again. Inspect radiator, hoses, and fittings for leaks.
16. Close drain valves and fill system. Refer to [Adding Coolant, page 341](#).
17. Close the platform. Refer to [5.3.2 Closing Platforms \(Standard Position\), page 288](#).
18. Close the hood. Refer to [5.2.4 Closing Hood \(Highest Position\), page 286](#).
19. Replace the cap (B).
20. Close the platform. Refer to [5.3.2 Closing Platforms \(Standard Position\), page 288](#).
21. Close the hood. Refer to [5.2.4 Closing Hood \(Highest Position\), page 286](#).

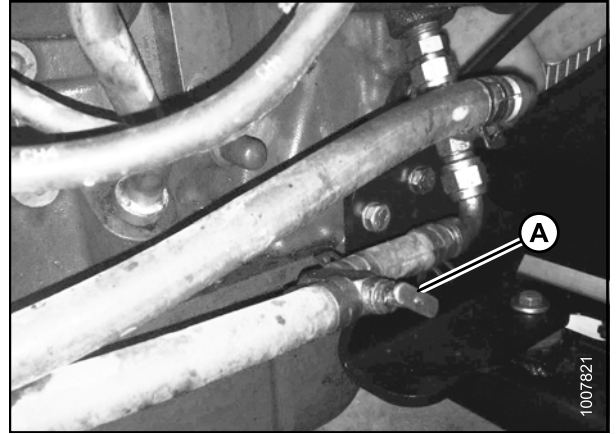

Figure 5.100: Heater Shut-Off Valve

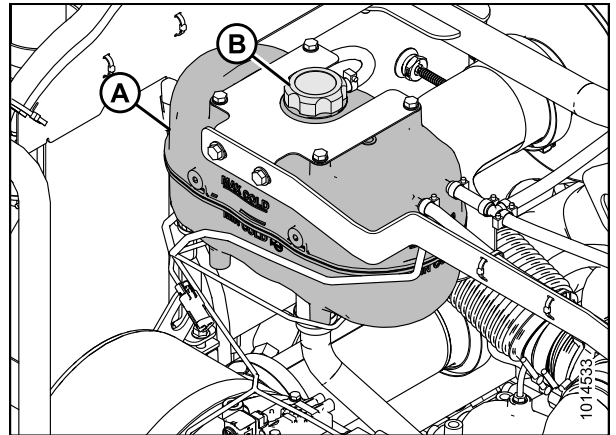

Figure 5.101: Coolant Recovery Tank

### Adding Coolant

Check the coolant level in the pressurized coolant tank daily, the tank should be at least one-half full. If less, add coolant.

### CAUTION

To avoid personal injury from hot coolant, do NOT turn pressurized coolant tank cap until engine cools.

To add coolant to the pressurized coolant tank, follow these steps:

1. Open the hood. Refer to [5.2.3 Opening Hood \(Highest Position\), page 285](#).
2. Open the platform. Refer to [5.3.1 Opening Platforms \(Standard Position\), page 287](#).

## MAINTENANCE AND SERVICING

- Remove the cap (B) from coolant recovery tank (A).

**NOTE:**

For coolant specifications, refer to [8.1.3 Lubricants, Fluids, and System Capacities](#), page 444.

- Add coolant at a rate not exceeding three gallons per minute until the recovery tank is one-half full.

**CAUTION**

Before starting the machine, check to be sure all bystanders have cleared the area.

- Start engine and run at high idle for approximately 20 minutes or until the engine temperature reaches 85°C (185°F).
- Check the coolant level again and add until the recovery tank is one-half full.
- Replace the cap (B).
- Close the platform. Refer to [5.3.2 Closing Platforms \(Standard Position\)](#), page 288.
- Close the hood. Refer to [5.2.4 Closing Hood \(Highest Position\)](#), page 286.

### 5.7.10 Gearbox

#### *Checking Lubricant Level and Adding Lubricant*

Lubricant level should be checked every 50 hours.

**CAUTION**

Park on a flat, level surface with the header on the ground and the ground speed lever in N-DETENT position with the steering wheel locked.

**DANGER**

To avoid bodily injury or death from unexpected startup of the machine, always stop the engine and remove the key from the ignition before leaving the operator's seat for any reason.

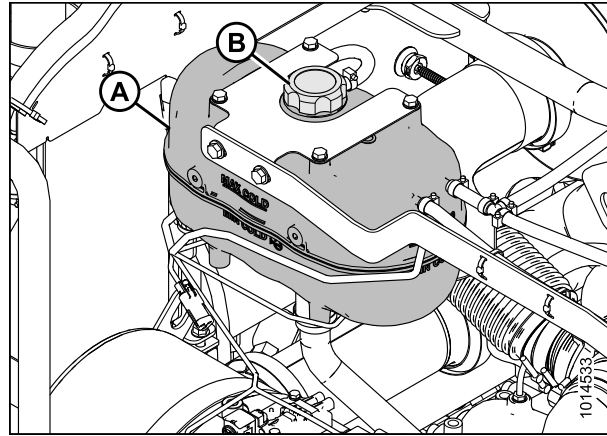

**Figure 5.102: Coolant Recovery Tank**

## MAINTENANCE AND SERVICING

1. Check and add lubricant as follows:
  - a. Park the windrower on level ground, shut down engine, and remove key.
  - b. Remove check plug (A). The lubricant should be visible through the hole or slightly running out.
  - c. If required, add lubricant through the check plug hole (A) using a squeeze bottle.

**NOTE:**

To view lubricant specifications, refer to [8.1.3 Lubricants, Fluids, and System Capacities, page 444](#).

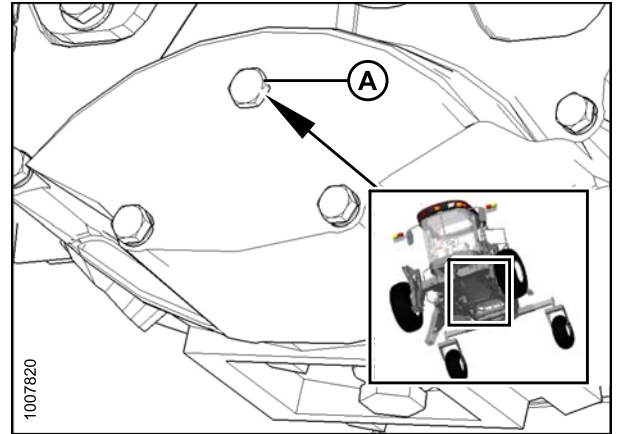

**Figure 5.103: Gearbox Lubricant Check Plug**

### Changing Lubricant

Change gearbox lubricant after the first 50 hours, and then at 500 hours as follows:

**NOTE:**

The engine should be warm when changing the oil.

1. Stop engine and remove key.
2. Place a 1 US gallon (4 liters) drain pan under the gearbox.
3. Remove drain plug (B) and allow oil to completely finish draining.
4. Install drain plug (B) and remove check plug (A).
5. Add lubricant. Refer to [Checking Lubricant Level and Adding Lubricant, page 342](#).
6. Operate the engine at low idle and check for leaks at the check plug and drain plug.

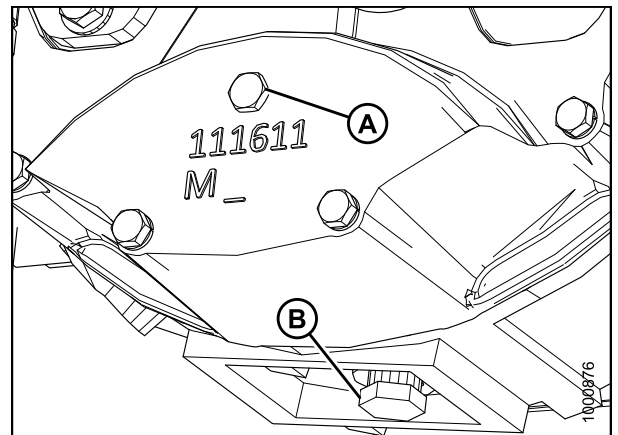

**Figure 5.104: Gearbox Lubricant Drain Plug**

## 5.7.11 Inspecting Exhaust System

The system consists of a two main canisters for exhaust treatment. In between the two exhaust canisters is a tube with a dosing module (DM) for diesel exhaust fluid (DEF).

### CAUTION

**Engine exhaust stack may be hot. To avoid burns, do NOT touch exhaust canister when engine is running. Allow sufficient cooling time after shut-down.**

The exhaust system requires no regular maintenance, but it should be inspected periodically as follows:

1. Open the hood to its highest position. For instructions, refer to [5.2.3 Opening Hood \(Highest Position\)](#), page [285](#).

**IMPORTANT:**

Ensure the exhaust system is secure to eliminate vibration.

2. Check the following:
  - a. Exhaust canisters (A) and bellow tube (B) for dents, cracks, and wear
  - b. Straps (C) for tightness
  - c. U-bolt (D) and marmon (E) clamps for breakage, cracks, and rust.

**IMPORTANT:**

A damaged bellow tube may cause safety issues and derate the engine.

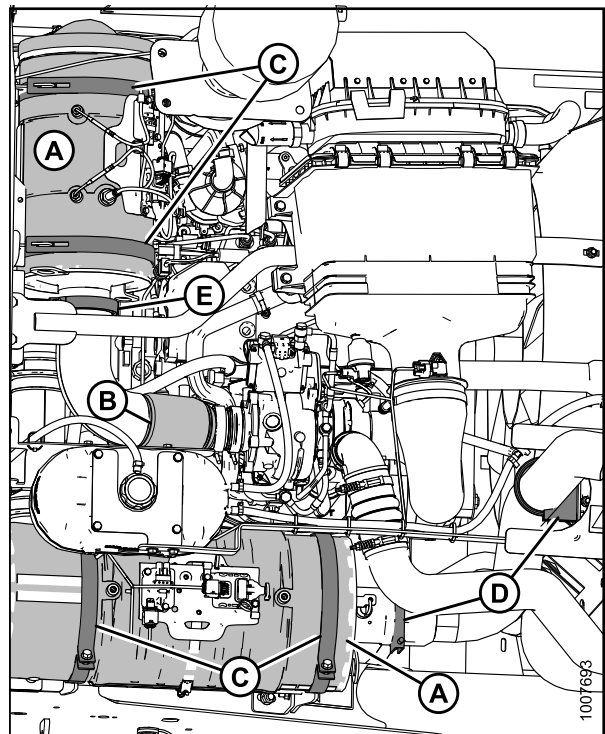

Figure 5.105: Exhaust System

## MAINTENANCE AND SERVICING

3. Check the four marmon clamps (A) securing the tubes in between the two exhaust canisters.

**IMPORTANT:**

Do **NOT** change exhaust canister type, piping sizes, or exhaust configuration. See your Dealer for proper replacement parts.

4. Inspect the area around clamps (A) for breakage, cracks, and rust-through.

**IMPORTANT:**

If exhaust is leaking, tighten clamps to 10 ft·lbf (13.5 N·m)  $\pm$ 1 ft·lbf (1.5 N·m). If leaking at marmon connection, replace seals (refer to the M155E4 Parts Catalog). Refer to your Dealer if exhaust leak persists.

5. Check tubing for dents or crushed areas. Dents or crushed portions of any tubing create exhaust flow restriction and increase back pressure significantly. Even relatively small dents will cause decreased fuel economy and increased turbo wear. If dents are relatively large, increased bearing and cylinder wear will occur due to increased exhaust temperature.

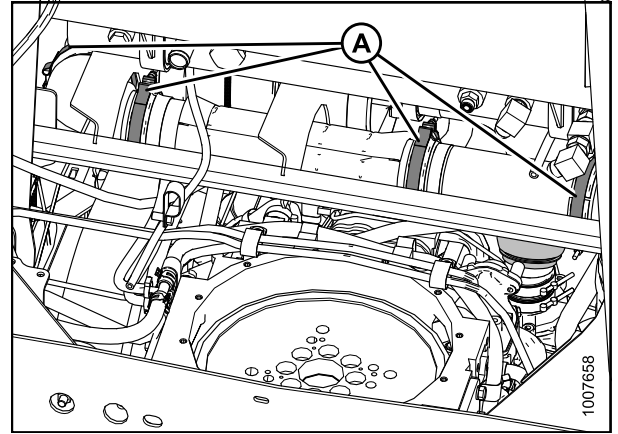

**Figure 5.106: Exhaust Canister**

### 5.7.12 Belts

#### *Tensioning Alternator/Fan Belt*

The alternator, water pump, and fan belt are automatically tightened. Manual adjustment is **NOT** required.

#### *Replacing Fan Belt*

### **DANGER**

**To avoid bodily injury or death from unexpected startup of the machine, always stop the engine and remove the key from the ignition before leaving the operator's seat for any reason.**

1. Shut down the engine and remove the key.
2. Open the left cab-forward platform. Refer to [5.3.1 Opening Platforms \(Standard Position\)](#), page 287.
3. Open the hood. Refer to [5.2.1 Opening Hood \(Lower Position\)](#), page 284.

## MAINTENANCE AND SERVICING

4. Loosen compressor mounting hardware (B) and push compressor towards engine to release tension.
5. Remove belt (A) from compressor.

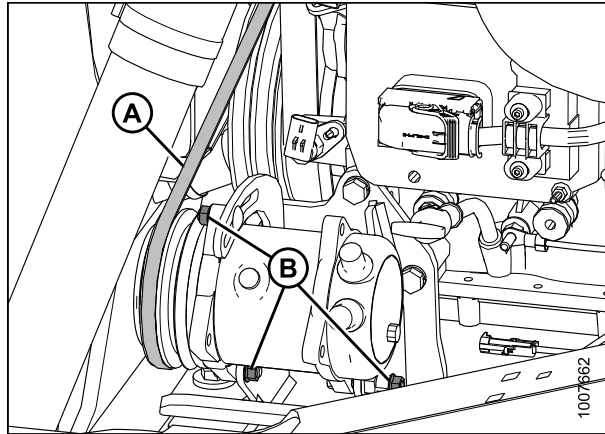

Figure 5.107: A/C Compressor

6. Insert the drive end of a 1/2 in. drive ratchet wrench into the belt tensioner (B).
7. Rotate tensioner counterclockwise until fan belt (A) can be slipped off pulley (C). Release tensioner and remove wrench.
8. Remove belt in order 1–2–3 as shown. Route fan belt around fan and remove belt.
9. Install new belt (A) around fan and onto pulleys in order 3–2–1.
10. Insert the drive end of a 1/2 in. drive ratchet wrench into the belt tensioner (B).
11. Rotate tensioner counterclockwise until belt (A) can be slipped onto pulley (C). Release tensioner and remove wrench.
12. Check that belt is properly seated in all pulley grooves.
13. Reinstall compressor belt (A).
14. Pry compressor away from engine so that a force of 8–12 lbf (35–55 N) deflects the belt (A) 3/16 in. (5 mm) at mid-span.
15. Tighten compressor mounting hardware (B).
16. Recheck tension and readjust as required.
17. Close the hood. Refer to [5.2.2 Closing Hood \(Lower Position\)](#), page 285.
18. Close the platform. Refer to [5.3.2 Closing Platforms \(Standard Position\)](#), page 288.

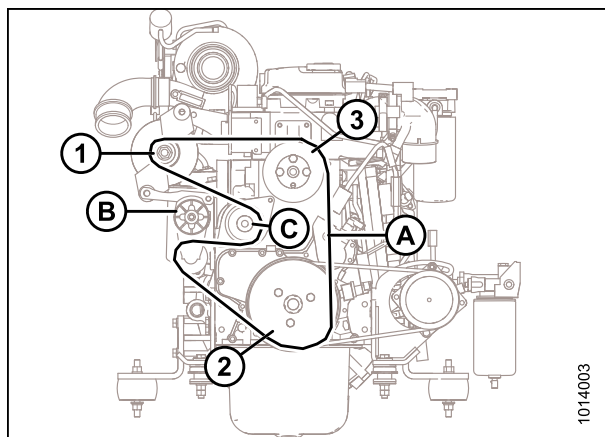

Figure 5.108: Engine Belts

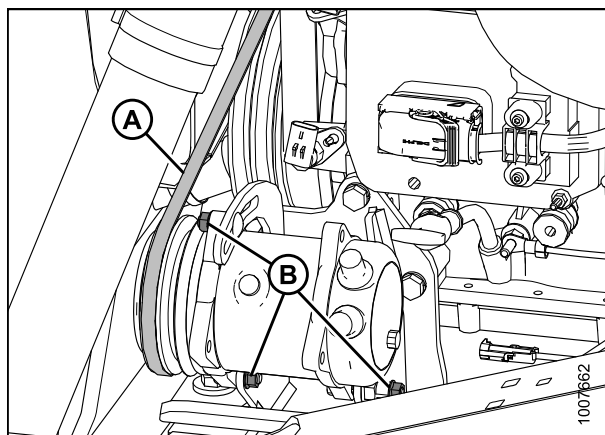

Figure 5.109: A/C Compressor

*Tensioning Air Conditioner (A/C) Compressor Belt*

**⚠ DANGER**

To avoid bodily injury or death from unexpected startup of the machine, always stop the engine and remove the key from the ignition before leaving the operator's seat for any reason.

1. Shut down the engine and remove the key.
2. Open the hood. Refer to [5.2.1 Opening Hood \(Lower Position\)](#), page 284.
3. Loosen compressor mounting hardware (B).
4. Pry compressor away from engine so that a force of 8–12 lbf (35–55 N) deflects the belt (A) 3/16 in. (5 mm) at mid-span.
5. Tighten compressor mounting hardware (B).
6. Recheck tension and readjust as required.
7. Close the hood. Refer to [5.2.2 Closing Hood \(Lower Position\)](#), page 285.

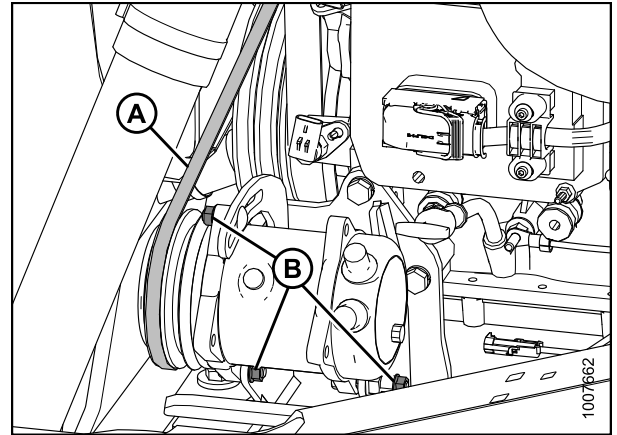

Figure 5.110: A/C Compressor

*Replacing Air Conditioner (A/C) Compressor Belt*

**⚠ DANGER**

To avoid bodily injury or death from unexpected startup of the machine, always stop the engine and remove the key from the ignition before leaving the operator's seat for any reason.

1. Shut down the engine and remove the key.
2. Open the hood. Refer to [5.2.1 Opening Hood \(Lower Position\)](#), page 284.
3. Loosen compressor mounting hardware (B) and push compressor towards engine to release tension.
4. Remove belt (A) from compressor.
5. Install new compressor belt (A).
6. Pry compressor away from engine so that a force of 8–12 lbf (35–55 N) deflects the belt (A) 3/16 in. (5 mm) at mid-span.
7. Tighten compressor mounting hardware (B).
8. Recheck tension and readjust as required.
9. Close the hood. Refer to [5.2.2 Closing Hood \(Lower Position\)](#), page 285.

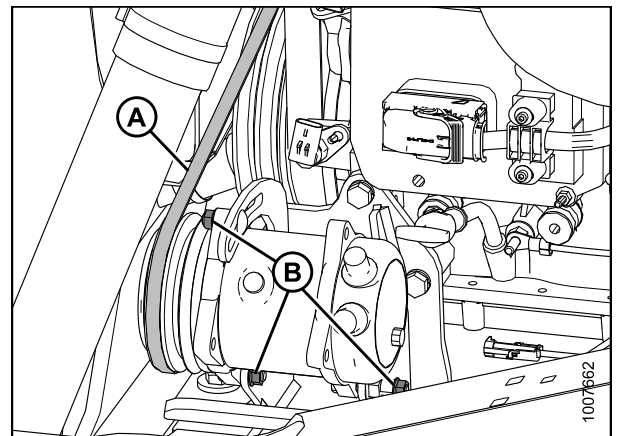

Figure 5.111: A/C Compressor

### 5.7.13 Engine Speed

The maximum and idle engine speeds are factory set.

Refer to [2.2 Specifications, page 30](#) for detailed information. If specified speeds cannot be maintained, see your MacDon Dealer.

Refer to [Engine Intermediate Speed Control \(ISC\), page 166](#) for additional information about engine speed.

#### *Throttle Adjustment*

The engine speed is controlled with the throttle lever that is connected to an electronic sensor inside the console.

The throttle lever in the cab should move the throttle sensor the full range between slow speed stop and full rpm stop without contacting the console at either position.

If the throttle lever is contacting the console and interferes with specified engine speeds, the sensor position may need adjustment. See your MacDon Dealer.



## 5.8 Maintaining Engine Cooling Box

Refer to the following procedures:

- [5.8.1 Opening Cooler Box Screen, page 349](#)
- [5.8.2 Cleaning Screens and Coolers, page 349](#)
- [5.8.3 Cleaning Cooler Box Components, page 350](#)
- [5.8.4 Adjusting Screen Cleaner Rotor to Screen Clearance, page 353](#)
- [5.8.5 Closing Cooler Box Screen, page 353](#)

### 5.8.1 Opening Cooler Box Screen

1. Open the hood. Refer to [5.2.3 Opening Hood \(Highest Position\), page 285](#).
2. Push latch (A) and open screen assembly access door (B). Secure with rod stored inside screen door.

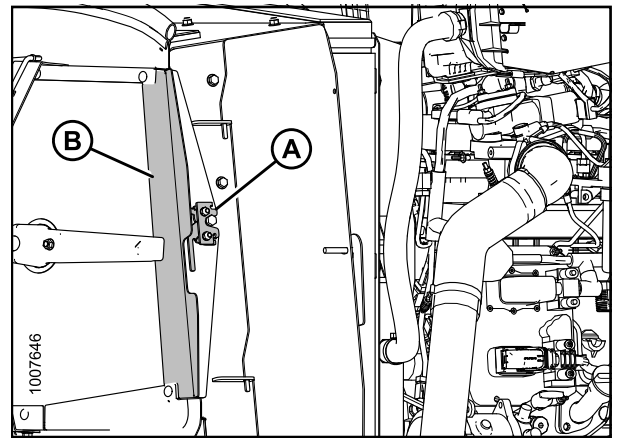

Figure 5.112: Engine Cooling System

### 5.8.2 Cleaning Screens and Coolers

The cooling box screen is cleaned using two electrically driven rotors and suction from the engine's cooling fan to sweep and vacuum the screen when the engine is running. If the screen is not being cleaned, the rotors or ducts may be plugged.

Follow these steps to clear plugged rotors:

1. Open the hood. Refer to [5.2.3 Opening Hood \(Highest Position\), page 285](#).
2. Remove nuts (B).
3. Pivot screen cleaner assembly (C) away from screen.
4. Blow out debris from cleaner ducts (A) with compressed air.
5. If ducts are plugged, open the cooler box screen. Refer to [5.8.1 Opening Cooler Box Screen, page 349](#).

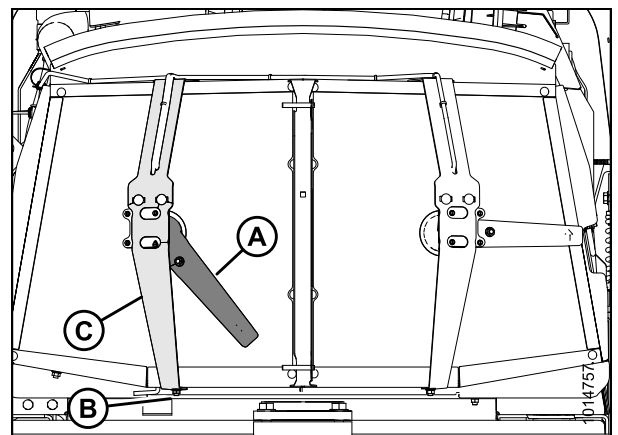

Figure 5.113: Screen Cleaner Assembly

## MAINTENANCE AND SERVICING

6. Blow debris out of ducts (A) with compressed air.
7. Clean screen with compressed air.

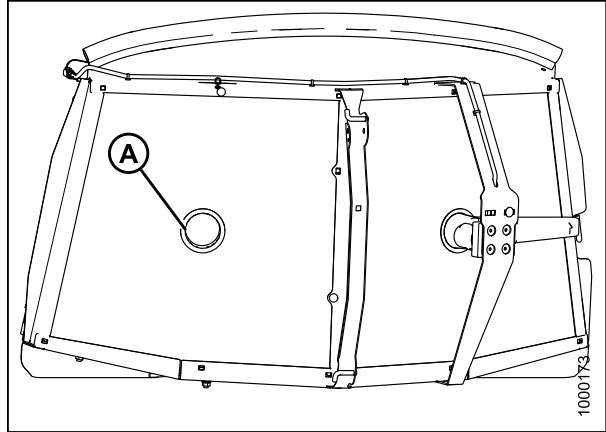

Figure 5.114: Cooler Box Screen

8. Move the screen cleaner assembly (C) back into position and secure with bolts and nuts (B).
9. Check duct (A) clearance to screen. Refer to [5.8.4 Adjusting Screen Cleaner Rotor to Screen Clearance](#), page 353.
10. Close the cooler box screen. Refer to [5.8.5 Closing Cooler Box Screen](#), page 353.
11. Close the hood. Refer to [5.2.4 Closing Hood \(Highest Position\)](#), page 286.

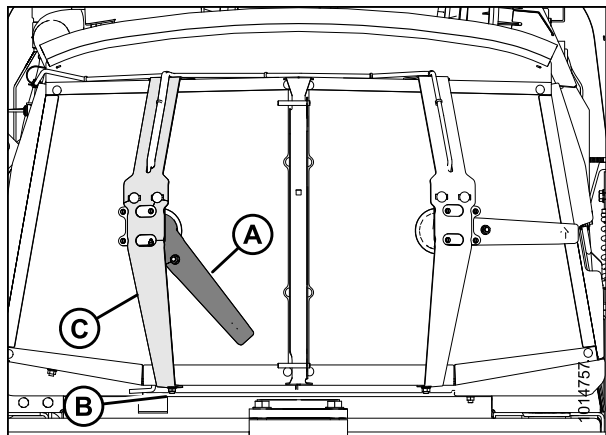

Figure 5.115: Screen Cleaner Assembly

### 5.8.3 Cleaning Cooler Box Components

The radiator and oil cooler should be cleaned daily with compressed air. More frequent cleaning may be necessary in severe conditions. The charge air cooler and air conditioning condenser may also be cleaned at the same time.

To clean these components, proceed as follows:

1. Open cooler box screen. Refer to [5.8.1 Opening Cooler Box Screen](#), page 349.

## MAINTENANCE AND SERVICING

2. Lift latch (A) and open the right-hand access door (B).

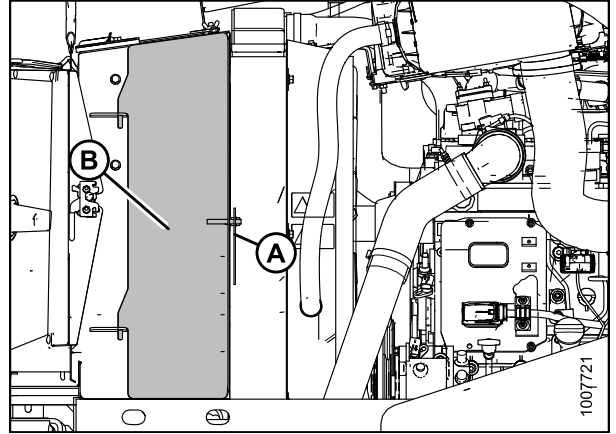

**Figure 5.116: RH Cooler Access Door**

3. Slide out the oil cooler/air conditioning condenser assembly (A).

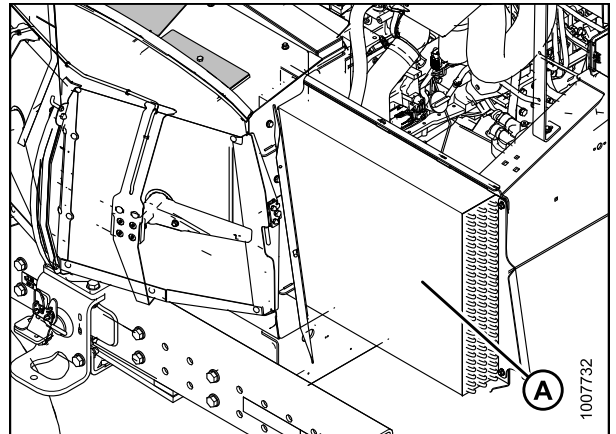

**Figure 5.117: A/C Condenser Assembly**

4. Lift latch (A) and open the left-hand access door (B).

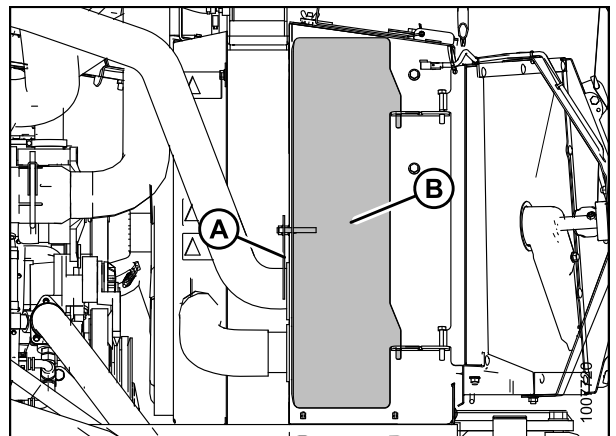

**Figure 5.118: LH Cooler Access Door**

## MAINTENANCE AND SERVICING

5. Remove wing nut (A) and open access door (B) at top of cooling box.

**NOTE:**

Fins on coolers can be very easily bent which may interfere with its function. Exercise caution when cleaning.

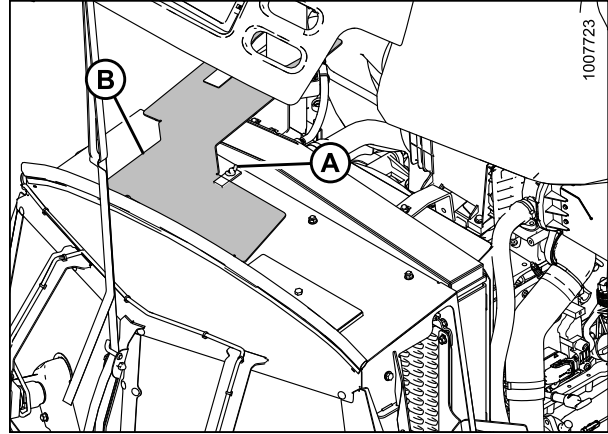

**Figure 5.119: Cooling Box Access Door**

6. Clean radiator (A) through access hole in cooling box with compressed air.
7. Clean oil cooler/air conditioning condenser (B), charge air cooler (C), and cooling box (D) with compressed air.
8. Inspect all lines and coolers for evidence of leaks and damage.
9. Slide oil cooler/air conditioning condenser (B) back into cooling box (D).
10. Close side access door and lock with lever.
11. Close access door on top of the cooling box and secure with wing nut.
12. Close cooler box screen. Refer to [5.8.5 Closing Cooler Box Screen, page 353](#).

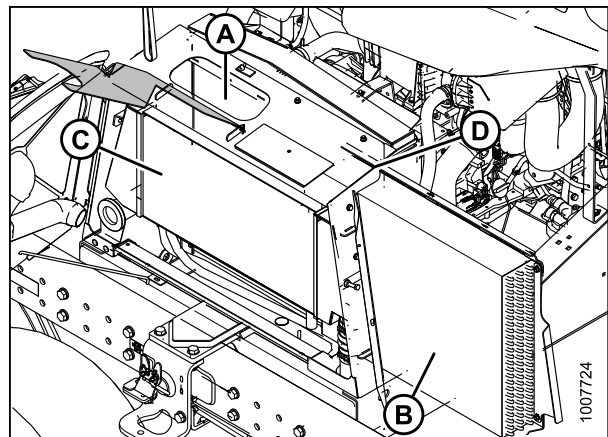

**Figure 5.120: Engine Cooling System**

### 5.8.4 Adjusting Screen Cleaner Rotor to Screen Clearance

Check clearance between trailing edge of screen cleaner rotor (A) and screen. It should be 0.039–0.314 in. (1–8 mm) at all locations when rotating.

**NOTE:**

Screen cleaner rotors rotate counterclockwise and may touch screen as long as they continue to rotate.

If necessary, adjust clearance as follows:

1. Open the hood. Refer to [5.2.1 Opening Hood \(Lower Position\)](#), page 284.
2. Loosen nut (B) on motor support (C).
3. Move support in or out until duct is 0.079–0.236 in. (2–6 mm) from screen near the center.
4. Retighten nut (B).
5. Loosen the two motor mount bolts (D).
6. Move motor/duct assembly (E) to obtain 0.039–0.314 in. (1–8 mm) gap to screen at full rotation of the rotor.
7. Retighten nuts (D) on motor mount.
8. Close the hood. Refer to [5.2.2 Closing Hood \(Lower Position\)](#), page 285.

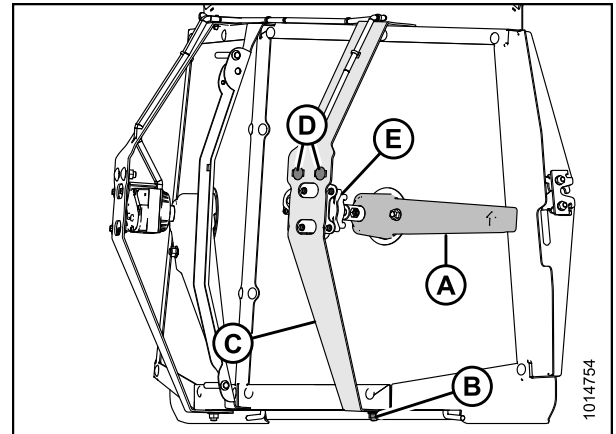

Figure 5.121: Screen Cleaner

### 5.8.5 Closing Cooler Box Screen

1. Unhook the support rod and store it in the screen door. Close screen access door (B) and engage latch (A).
2. Close the hood. Refer to [5.2.4 Closing Hood \(Highest Position\)](#), page 286.

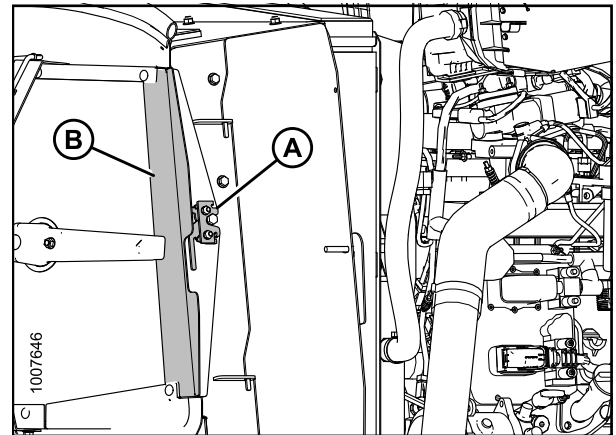

Figure 5.122: Engine Cooling System

## 5.9 Electrical System

### 5.9.1 Preventing Electrical System Damage

To prevent electrical system damage, take the following precautions:

- Carefully observe polarity when attaching booster battery.
- Do **NOT** short across battery or alternator terminals, or allow battery positive (+) cable or alternator wire to become grounded.
- Be sure alternator connections are correct before cables are connected to battery.
- When welding on any part of the machine, disconnect battery cables and alternator wire. Refer to [1.8 Welding Precaution, page 9](#).
- Always disconnect battery ground cable when working with the alternator or regulator.
- Never attempt to polarize alternator or regulator.
- If wires are disconnected from the alternator, use the illustration to ensure proper connections.
- Never ground the alternator field terminal or field.
- Never connect or disconnect alternator or regulator wires with battery connected or alternator operating.
- Always disconnect cables from the battery when using a charger to charge battery in windrower.
- Ensure all cables are securely connected before operating engine.

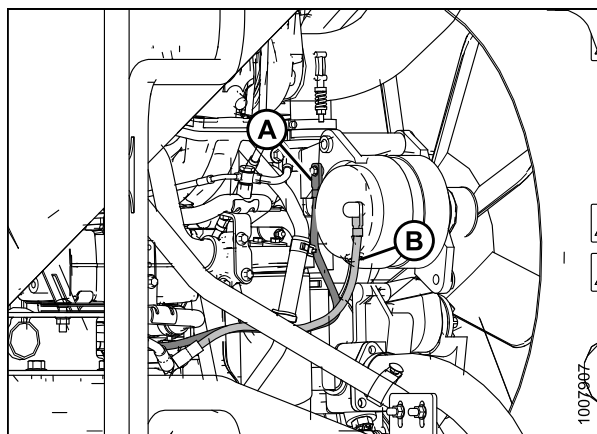

**Figure 5.123: Alternator**

A - Negative Terminal

B - Positive Terminal

### 5.9.2 Battery

#### *Maintaining the Battery*

#### **⚠ CAUTION**

**Do NOT attempt to service battery unless you have the proper equipment and experience to perform the job. Have it done by a qualified Dealer.**

- Check battery charge once a year, more often if operating in cold weather. Hydrometer readings should be 1.260 to 1.300. Readings below 1.250 indicate charging is required. Refer to [Charging the Battery, page 356](#). Add electrolyte if necessary. Refer to [Adding Electrolyte to the Battery, page 358](#).
- Keep batteries clean by wiping with a damp cloth.
- Keep all connections clean and tight. Remove any corrosion and wash terminals with a solution of baking soda and water. A light coating of grease on terminals (after cables are attached) will reduce corrosion.
- To prolong battery life, store batteries fully charged and at +20° to +80°F (-7° to +26°C). Check voltage after storage and recharge as needed according to battery and charger manufacturer recommendations.

## MAINTENANCE AND SERVICING

- Do **NOT** stack storage batteries on top of each other.

### *Battery Main Disconnect Switch*

A battery main disconnect switch (A) is located on the right cab-forward side frame rail, just behind the batteries, and can be easily accessed by moving the maintenance platform.

Ensure the switch is in the POWER OFF position when servicing electrical components, or to prevent loss of battery charge when the windrower will not be used for long periods.

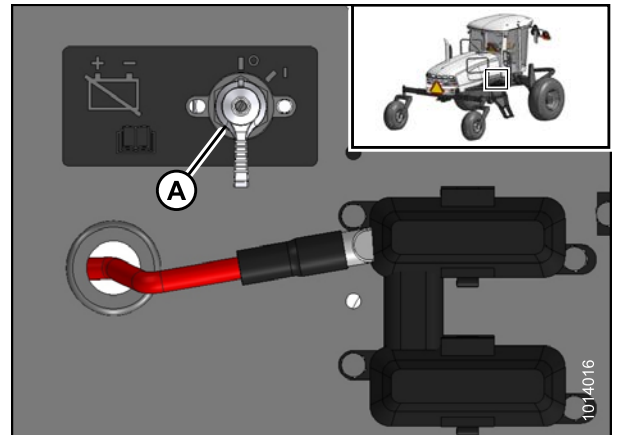

**Figure 5.124: Electrical System**

Charging the Battery

**CAUTION**

- Ventilate the area where batteries are being charged.
- Do NOT charge a frozen battery. Warm to 60°F (16°C) before charging.
- Do NOT connect or disconnect live circuits. To prevent sparks, turn off charger and connect positive cable first. PROTECT YOUR EYES.
- If charging battery in windrower, disconnect POSITIVE battery cable before connecting charger cable, then connect ground cable last, away from battery.
- Stop or cut back charging rate if battery feels hot, or is venting electrolyte. Battery temperature must NOT exceed 125°F (52°C).
- The maximum charge rate in amperes should be NO MORE than 1/3 of the battery's reserve capacity minute rating. If the terminal voltage exceeds 16.0 volts while charging, reduce the charge rate.
- Continue charging and reduce the rate as needed until a two hour period results in no increase in voltage or decrease in current.

**WARNING**

- Gel and AGM (Absorbed Glass Mat) batteries require a voltage-limited charger. Charging a Gel or AGM battery on a typical shop charger—even one time—may greatly shorten its life.
- If the electrolyte is accessible, verify that plates are covered before beginning to charge. At the end of charge, add distilled water as needed to bring levels to the proper height. If water is added, charge for an additional 30 minutes to mix. If electrolyte levels are low, but battery is not accessible, remove battery from service.

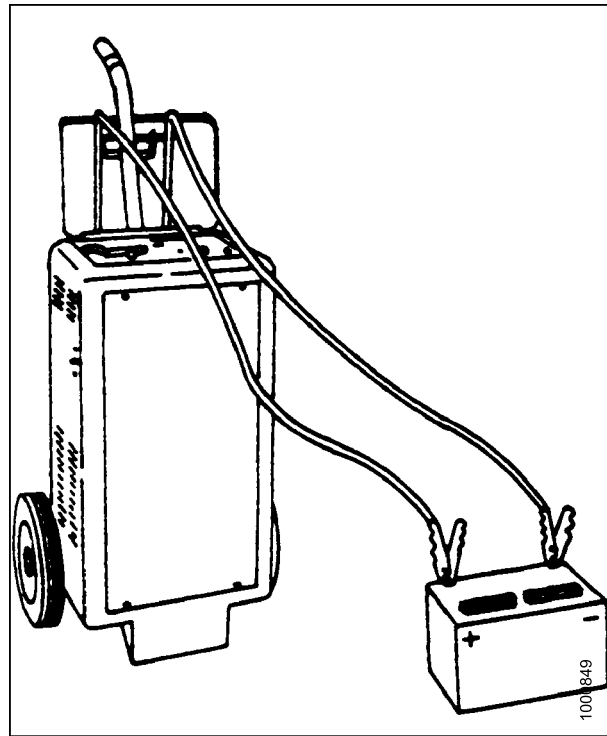

Figure 5.125: Charging Battery

Table 5.1 Voltage Chart

Voltage	State of Charge (%)	Approximate Battery Charging Time <sup>28</sup> to Full Charge at 80°F/27°C. (Minutes)			
		Maximum Rate at (Amps)			
Standard Battery					
12 Volts		50	30	20	10
12.6	100	— FULL CHARGE —			
12.4	75	20	35	48	90
12.2	50	45	75	95	180
12.0	25	65	115	145	280
11.8	0	85	150	195	370

28. Charging time depends upon battery capacity, condition, age, temperature, and efficiency of charger.



**⚠ CAUTION**

Follow all instructions and precautions furnished by the battery charger manufacturer, including the following:

- Charge at recommended rates and times.
- Turn off charger prior to hook up to avoid dangerous sparks. Wear proper eye protection.
- Reduce charge rate if the terminal voltage is higher than 16.0 volts while charging. The maximum charge rate in amperes should NOT exceed 1/3 of the battery's reserve capacity minute rating.
- Continue charging if there is no change in voltage or current for a period of two-hour and reduce the rate as needed.
- If the battery case gets hot during charging or spews large amount of gasses, temporarily stop charging.

**IMPORTANT:**

NEVER overcharge batteries. Excessive charging will shorten battery life.

To charge battery, follow these steps:

**⚠ DANGER**

To avoid bodily injury or death from unexpected startup of the machine, always stop the engine and remove the key from the ignition before leaving the operator's seat for any reason.

1. Stop the engine and remove the key.
2. Move platform on right cab-forward side of machine to open position to allow access to the batteries. Refer to [5.3.1 Opening Platforms \(Standard Position\), page 287](#).
3. Remove red plastic cover (A) from positive cable clamps.
4. Remove black plastic cover (B) from negative terminals.
5. If charging battery in windrower, disconnect **positive** battery cable (A), then connect charger cable to positive post. Connect charger ground cable to the engine block last, away from battery.
6. Charge batteries in accordance with charger manufacturer's instructions.
7. Close platform. Refer to [5.3.2 Closing Platforms \(Standard Position\), page 288](#).

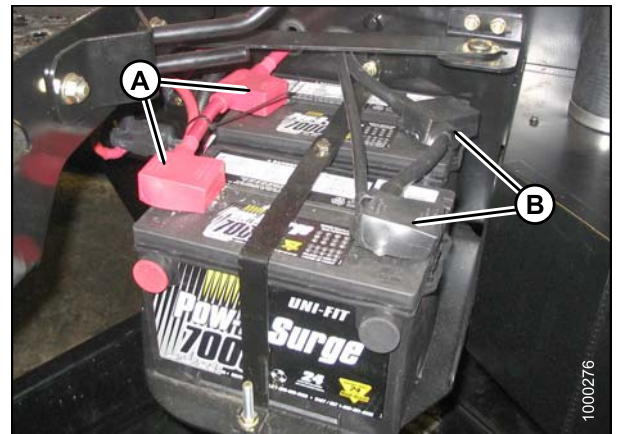

**Figure 5.126: Battery Terminal Location**

A - Positive Terminals

B - Negative Terminals

### *Boosting the Battery*

A 12 volt battery can be connected in parallel (+ to +) with the windrower battery. Use heavy-duty battery cables.

#### **⚠ CAUTION**

- Gas given off by batteries is explosive. Keep sparks and flames away from batteries.
- Make last connection and first disconnection at the point furthest away from the batteries.
- Wear protective eye-wear when using a booster battery.
- Be sure everyone is clear of machine when starting engine. Start engine from operator's station only.

1. Open the hood. Refer to [5.2.1 Opening Hood \(Lower Position\)](#), page 284.
2. Remove red rubber cover from boost post (A) on windrower frame.
3. Attach one end of battery cable to positive (+) terminal of booster battery, and other end to positive boost post (A) on windrower frame.
4. Attach second cable to negative (-) terminal of booster battery, and then to ground post (B) on windrower frame.
5. Turn ignition switch in cab as with normal start up.
6. After engine starts, disconnect cable from windrower ground first, and then disconnect the other cables.
7. Replace rubber cover on boost post (A).
8. Close the hood. Refer to [5.2.2 Closing Hood \(Lower Position\)](#), page 285.

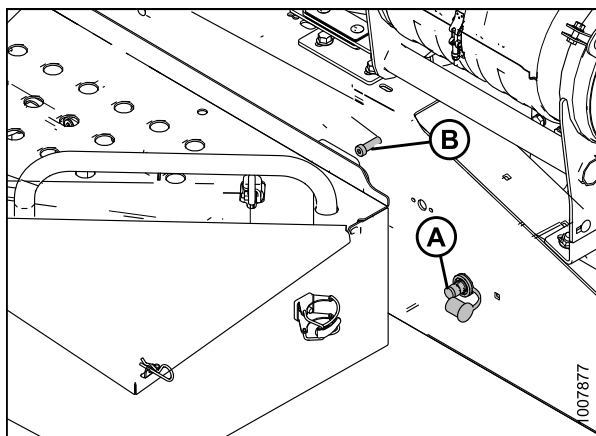

**Figure 5.127: Battery Boost Posts**

### *Adding Electrolyte to the Battery*

Before servicing batteries, consult the battery manufacturer's instructions for proper procedures and safety precautions.

#### **⚠ WARNING**

- Keep all smoking materials, sparks, and flames away from electrolyte container and battery, as gas given off by electrolyte is explosive.
- Battery electrolyte causes severe burns. Avoid contact with skin, eyes or clothing. Wear protective eyewear and heavy gloves.



**Figure 5.128: Battery Safety**

**⚠ WARNING**

- If electrolyte is spilled or splashed on clothing or on the body, neutralize it immediately with a solution of baking soda and water, then rinse with clean water.
- Electrolyte splashed into the eyes is extremely dangerous. Should this occur, force the eye open, and flood with cool, clean water for five minutes. Call a Doctor immediately.

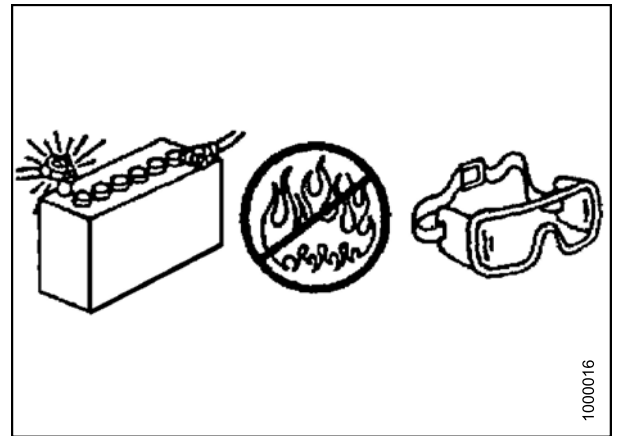

Figure 5.129: Battery Safety

**⚠ DANGER**

To avoid bodily injury or death from unexpected startup of the machine, always stop the engine and remove the key from the ignition before leaving the operator's seat for any reason.

1. If the batteries are installed in the windrower, stop the engine and remove the key.
2. Open the platform on the right side of the cab. Refer to [5.3.1 Opening Platforms \(Standard Position\), page 287](#).
3. Add electrolyte in accordance with the battery manufacturer's instructions.
4. Close the platform. Refer to [5.3.2 Closing Platforms \(Standard Position\), page 288](#).

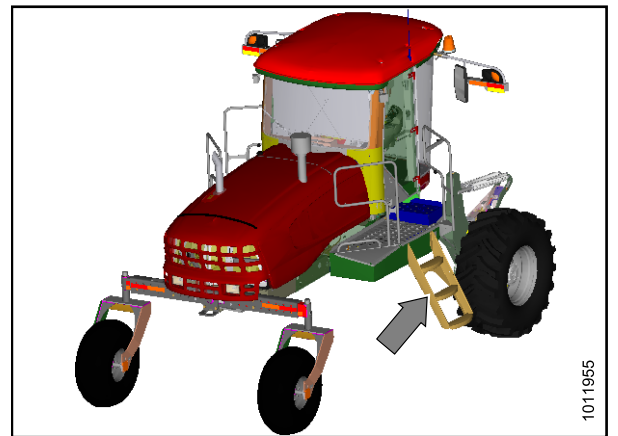

Figure 5.130: Platform Location

*Removing Batteries*

**⚠ CAUTION**

Do not attempt to service battery unless you have the proper equipment and experience to perform the job. Have it done by a qualified Dealer.

**⚠ DANGER**

To avoid bodily injury or death from unexpected startup of the machine, always stop the engine and remove the key from the ignition before leaving the operator's seat for any reason.

1. Stop the engine and remove the key.
2. Open the right cab-forward platform to expose the batteries. Refer to [5.3.1 Opening Platforms \(Standard Position\), page 287](#).

## MAINTENANCE AND SERVICING

3. Ensure the battery switch (A) is turned to the POWER OFF position (the battery switch is located on the right-hand frame rail beside the batteries).

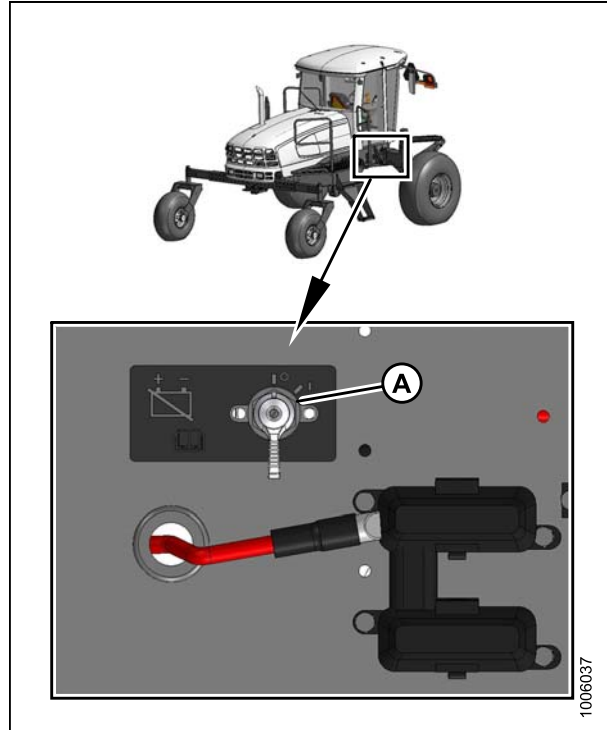
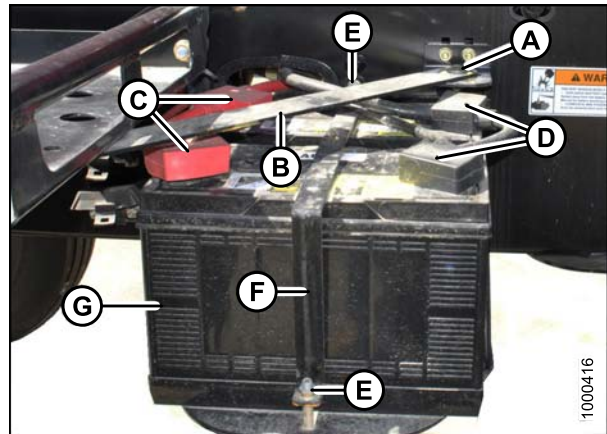

**Figure 5.131: Battery Switch**

4. Remove the bolt (A) that secures the platform arm to the platform. Swing arm (B) out of the way.
5. Remove the black plastic cover from the negative cable clamps (D). Loosen clamps and remove cable from batteries.
6. Remove the red plastic cover from positive cable clamps (C). Loosen the clamps and remove cable from batteries.
7. Remove bolts (E) securing strap (F) to frame, and remove strap.
8. Lift batteries off holder (G).

**NOTE:**

Dual battery support can be removed from frame by simply lifting support, and pulling it away from frame.



**Figure 5.132: Battery**

### *Installing Batteries*

Replacement batteries must meet the specifications shown in the following table:

**Table 5.2 Battery Specification**

Rating	Group	CCA (min)	Volt	Maximum Dimension
Heavy duty, off-road, vibration resistant	BCI 29H or 31A	650	12	13.25 x 7.37 x 9.44 in. (334 x 188 x 232 mm)

## MAINTENANCE AND SERVICING

1. Ensure the battery switch (A) is turned to the POWER OFF position (the battery switch is located on the right-hand frame rail beside the batteries).
2. Open the right cab-forward platform to expose the batteries. Refer to [5.3.1 Opening Platforms \(Standard Position\)](#), page 287.
3. Remove cable ties securing battery cables to battery clamp.

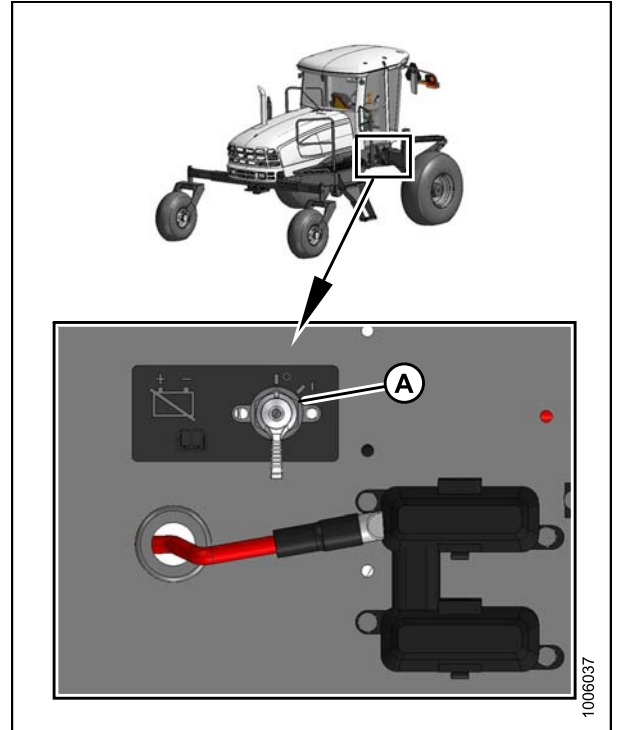

Figure 5.133: Battery Switch

4. Position new batteries (G) on dual battery support.

**NOTE:**

Ensure that batteries are positioned so that the positive posts (C) face aft.

5. Install strap (F) with bolts (E).
6. Rotate bar (B) into position and secure with bolt (A).
7. Connect battery cables. Refer to [Connecting Batteries](#), page 361.
8. Close the platform. Refer to [5.3.2 Closing Platforms \(Standard Position\)](#), page 288.

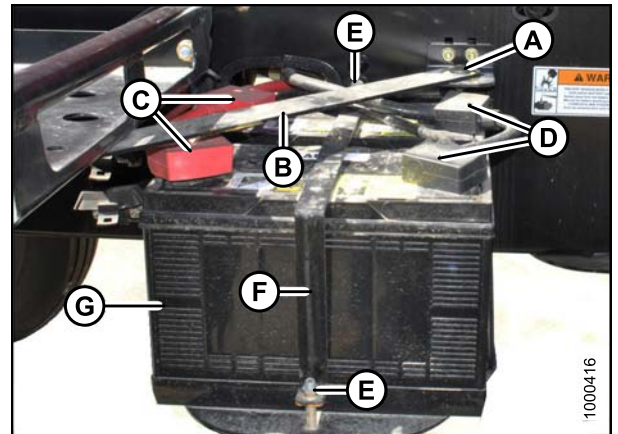

Figure 5.134: Battery

### Connecting Batteries

#### **DANGER**

To avoid bodily injury or death from unexpected startup of the machine, always stop the engine and remove the key from the ignition before leaving the operator's seat for any reason.

## MAINTENANCE AND SERVICING

1. Stop engine and remove key from ignition.
2. Open the right-hand (cab-forward) maintenance platform. Refer to [5.3.1 Opening Platforms \(Standard Position\)](#), page 287.
3. Ensure the battery switch (A) is turned to the POWER OFF position (the battery switch is located on the right-hand frame rail beside the batteries).
4. Remove the cable ties securing the battery cables to the battery clamps.

### IMPORTANT:

**Batteries are negative grounded.** Always connect red starter cables to the positive (+) terminals of the batteries and black ground cables to the negative (-) terminals of the batteries. Reversed polarity in the batteries or alternator may result in permanent damage to the electrical system.

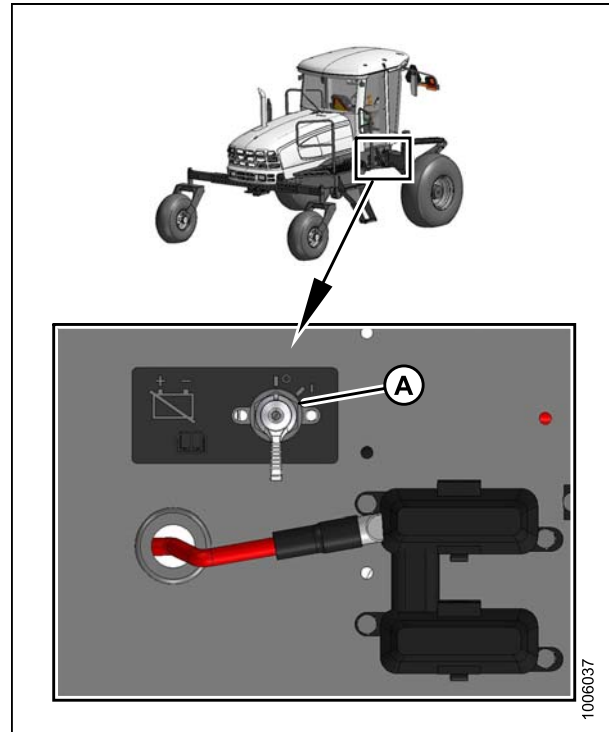

Figure 5.135: Battery Switch

5. Remove the plastic caps from the battery posts.
6. Attach the red positive (+) cable terminals to the positive posts (A) on the batteries and tighten clamps. Reposition plastic covers onto clamps.
7. Attach the black negative (-) cable terminals to the negative posts (B) on the batteries and tighten clamps. Reposition plastic covers onto clamps.
8. Turn the battery switch to the POWER ON position.
9. Close the platform. Refer to [5.3.2 Closing Platforms \(Standard Position\)](#), page 288.

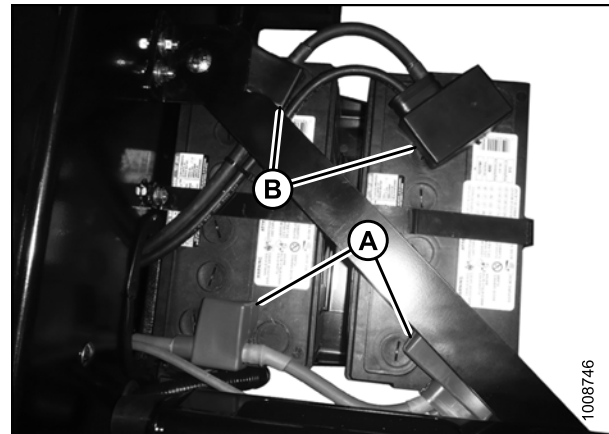

Figure 5.136: Batteries

### 5.9.3 Headlights: Engine-Forward

#### Aligning Headlights

### DANGER

To avoid bodily injury or death from unexpected startup of the machine, always stop the engine and remove the key from the ignition before leaving the operator's seat for any reason.

#### NOTE:

Header should be attached and raised to maintain proper windrower stance.

## MAINTENANCE AND SERVICING

1. Position windrower on level ground in front of a vertical surface in accordance with the illustration.
2. Shut down engine and remove key.

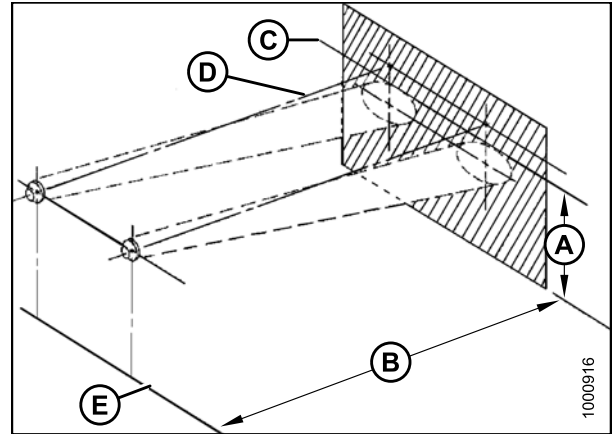

**Figure 5.137: Headlight Beam Positioning**

- A - 49-3/4 in. (1263 mm) Maximum
- B - 25 ft (7.5 m)
- C - Top Edge of Beam
- D - Beam Centered on Direction of Travel Line
- E - Ground

3. Turn on ROAD (A) lights and switch to low beam (B).

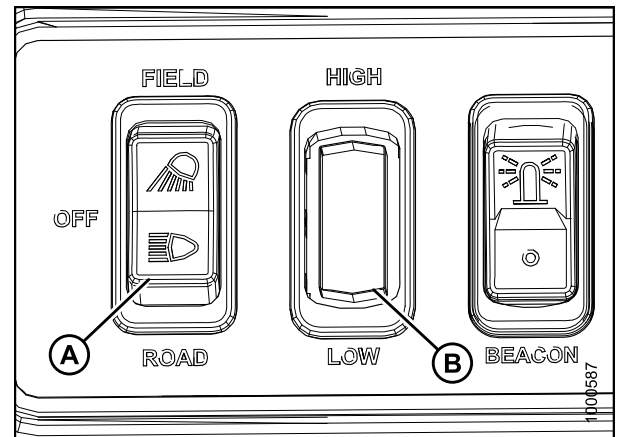

**Figure 5.138: Road Light Switch**

4. Align the headlights to the following specifications by turning adjusting screws (A).
  - Adjustments are for low beam.
  - Light beams laterally centered on the direction of travel line from the headlights (that is, **NOT** skewed left or right).



**Figure 5.139: Headlights**

## MAINTENANCE AND SERVICING

- Upper limit of the beam **NOT** higher than 49-3/4 in. (1263 mm) above ground at a distance of 25 ft. (7.5 m) from the headlight.

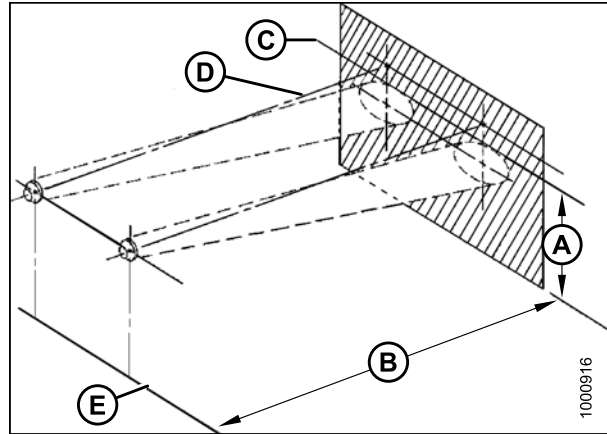

**Figure 5.140: Headlight Beam Positioning**

- A - 49-3/4 in. (1263 mm) Maximum
- B - 25 ft (7.5 m)
- C - Top Edge of Beam
- D - Beam Centered on Direction of Travel Line
- E - Ground

### Replacing Headlight Bulb

1. Remove two screws (A) and remove headlight assembly from hood.



**Figure 5.141: Headlight**

2. Pull wiring harness connector off the headlight assembly and remove rubber insulator boot (A).

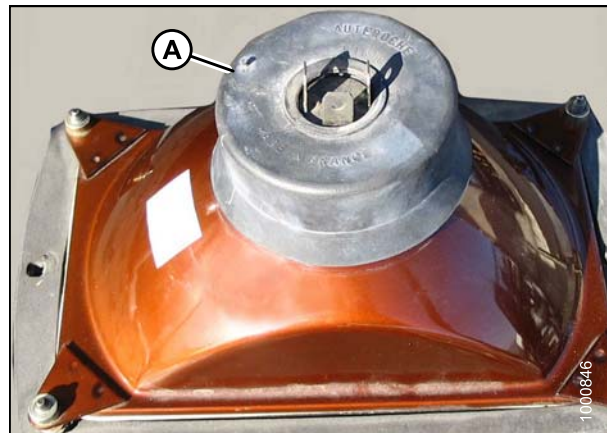

**Figure 5.142: Headlight Assembly**



## MAINTENANCE AND SERVICING

3. Pinch the wire retainer (A) and lift away from hooks.
4. Remove bulb (B) from body.

**IMPORTANT:**

Do **NOT** touch the glass of the halogen bulb as the oils or other chemicals from your skin will cause the bulb to fail prematurely.

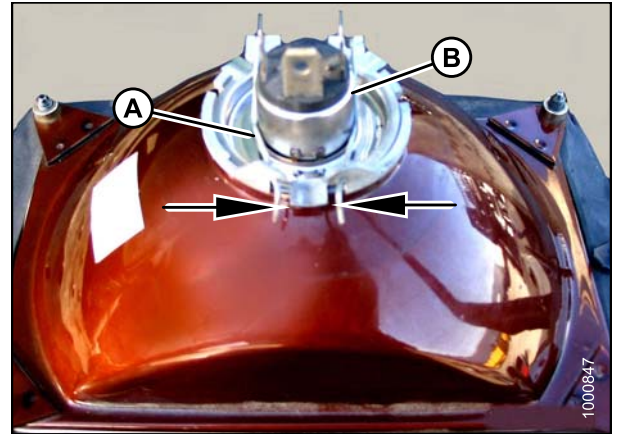

Figure 5.143: Headlight Assembly

5. Align lugs (B) on new bulb with slots (C) in body and push into place.
6. Secure bulb with wire retainer (A).

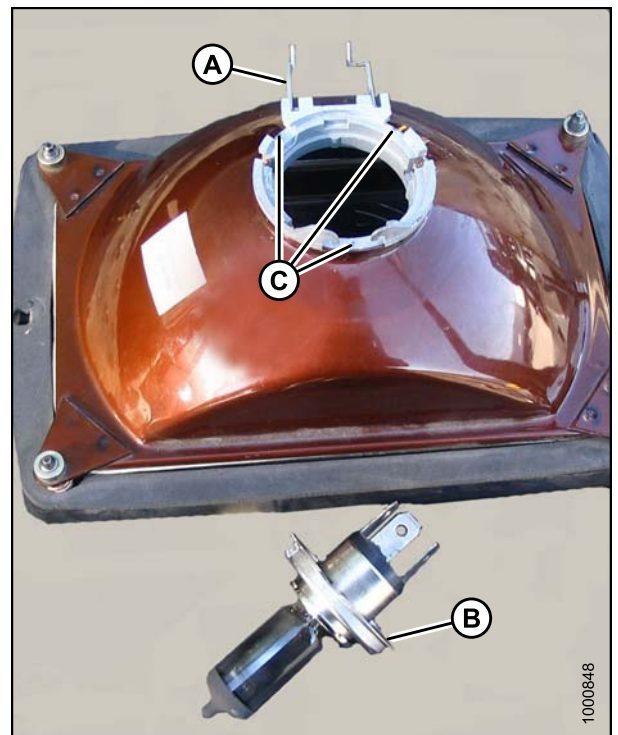

Figure 5.144: Headlight Assembly

## MAINTENANCE AND SERVICING

7. Replace rubber insulator boot (A).
8. Push connector onto light bulb.

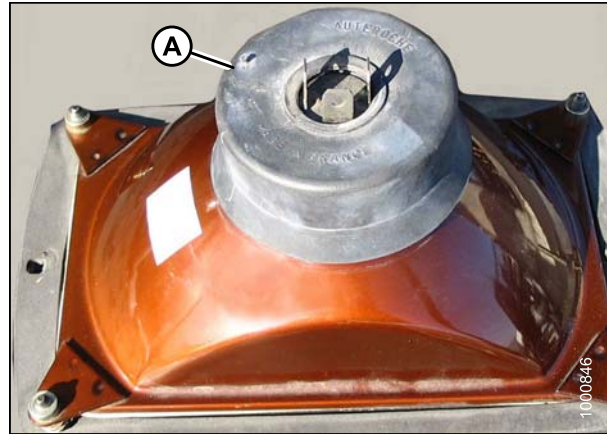

Figure 5.145: Headlight Assembly

9. Position headlight into light receptacle, ensuring top is up, and secure with screws (A).

**NOTE:**

Aligning of light should not be necessary.



Figure 5.146: Headlight

### 5.9.4 Field Lights: Cab-Forward

#### *Adjusting Field Lights*

The field lights are best adjusted with the machine in the field (or equivalent) to suit Operator preference.

#### **⚠ DANGER**

To avoid bodily injury or death from unexpected startup of the machine, always stop the engine and remove the key from the ignition before leaving the operator's seat for any reason.

1. Hold onto handholds (A) on the cab front corners, and stand on header anti-slip strips.

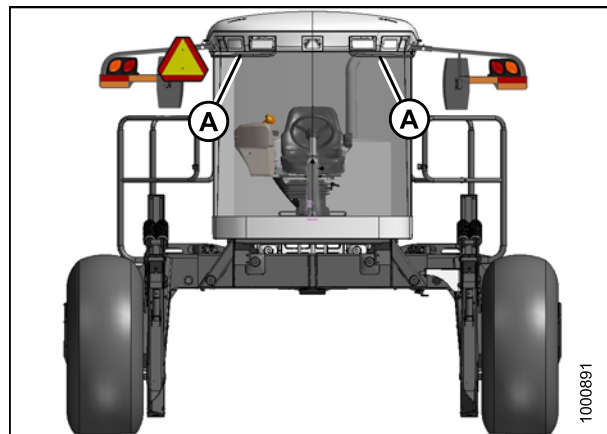

Figure 5.147: Field Lights

2. Adjust lights with screws (A).

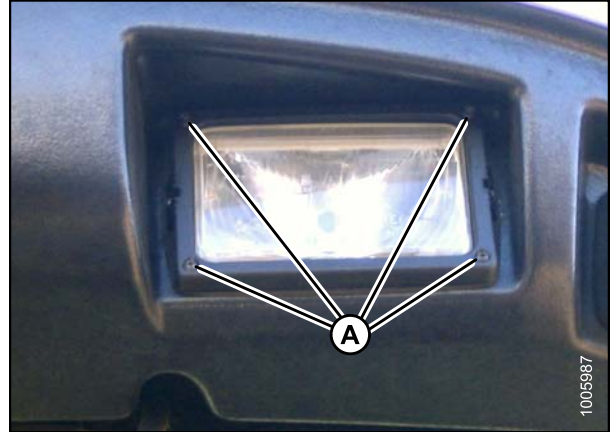

Figure 5.148: Field Lights

### *Replacing Field Light Bulb*

1. Remove two screws (A), and remove light assembly.
2. Replace bulb as described in [Replacing Field Light Bulb, page 367](#).

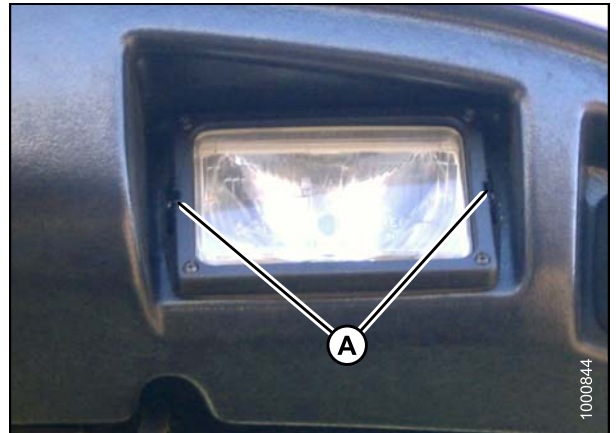

Figure 5.149: Field Lights

## 5.9.5 Flood Lights: Forward

### *Adjusting Forward Flood Lights*

The forward flood lights are **NOT** adjustable.

### *Replacing Bulb in Cab-Forward Flood Light*

#### **DANGER**

To avoid bodily injury or death from unexpected startup of the machine, always stop the engine and remove the key from the ignition before leaving the operator's seat for any reason.

Replace bulbs as follows:

1. Shut down engine and remove key. Turn lights OFF.

## MAINTENANCE AND SERVICING

2. Hold onto the handholds (A) on the cab front corners and stand on the header anti-slip strips when removing the forward field lights.
3. Remove two screws (B) and remove light bezel (C).
4. Remove light from receptacle.

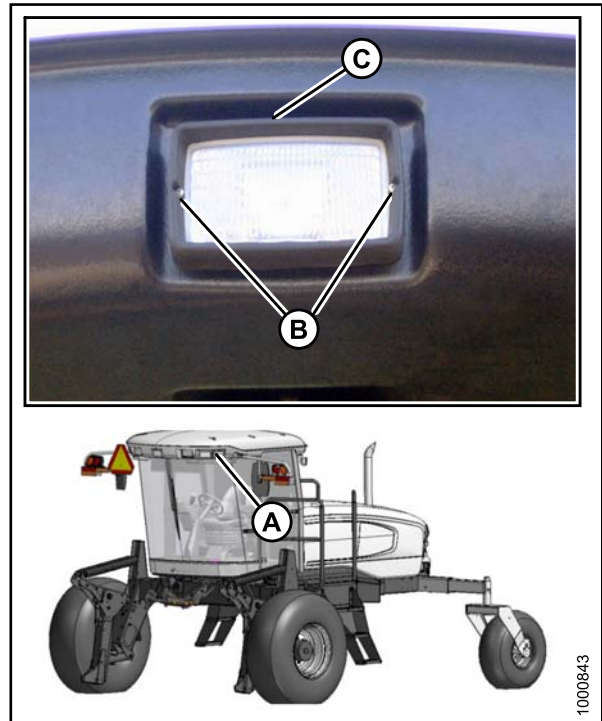

Figure 5.150: Forward Flood Lights

5. Pinch the wire retainer (A) and lift away from hooks.
6. Remove bulb (B) from body and pull wire from connector (C).

**IMPORTANT:**

Do **NOT** touch the glass of the halogen bulb as the oils or other chemicals from your skin will cause the bulb to fail prematurely.

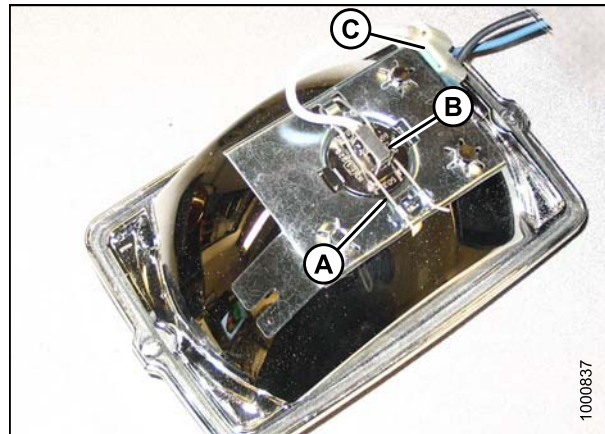

Figure 5.151: Flood Light Assembly

## MAINTENANCE AND SERVICING

7. Match slots on new bulb (B) with lugs (D) in optical unit and insert bulb into unit.
8. Secure bulb with wire retainer (A).
9. Push wire into connector (C).

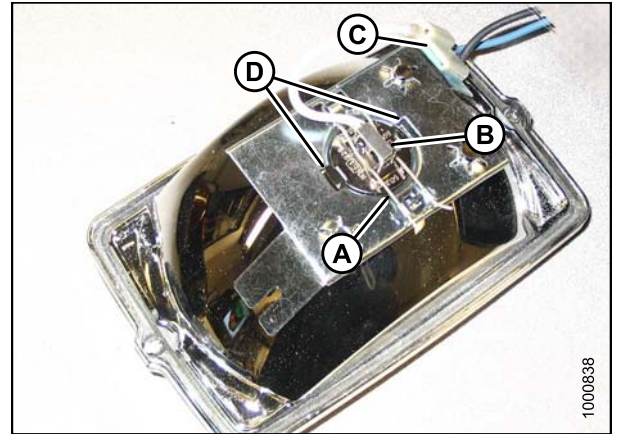

Figure 5.152: Flood Light Assembly

10. Position light into light receptacle, ensuring top is up and secure with bezel (C) and screws (B).

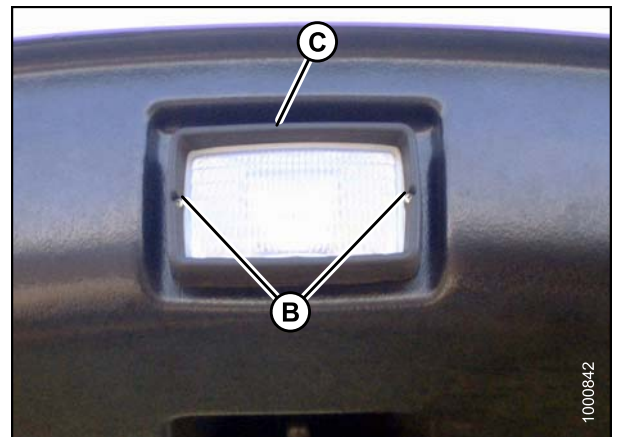

Figure 5.153: Forward Flood Light

### 5.9.6 High-Intensity Discharge (HID) Auxiliary Lighting (Optional - MD #B5596)

Two optional HID lights provide additional lighting during field operation. They operate only in cab-forward mode.

*Replacing High-Intensity Discharge (HID) Auxiliary Lights (if Installed)*

#### **DANGER**

To avoid bodily injury or death from unexpected startup of the machine, always stop the engine and remove the key from the ignition before leaving the operator's seat for any reason.

## MAINTENANCE AND SERVICING

To remove and replace the lamp only, follow these steps:

1. Shut down engine and remove key. Turn lights OFF.

**NOTE:**

Hold onto the handholds (A) on the cab front corners and stand on the header anti-slip strips, or stand on the maintenance platform when accessing the HID auxiliary lights.

2. Remove the nut, spring washer, and bolt (A) that secure the lamp (B) to lamp bracket (C).
3. Remove lamp (B).
4. Position the new lamp (B) in lamp bracket (C) and secure with bolt (A), spring washer, and nut.
5. Adjust lamp (B) to desired position and tighten bolt (A).

To remove and replace the HID lamp assembly, follow these steps:

1. Disconnect lamp connector (A) from electrical harness (B).

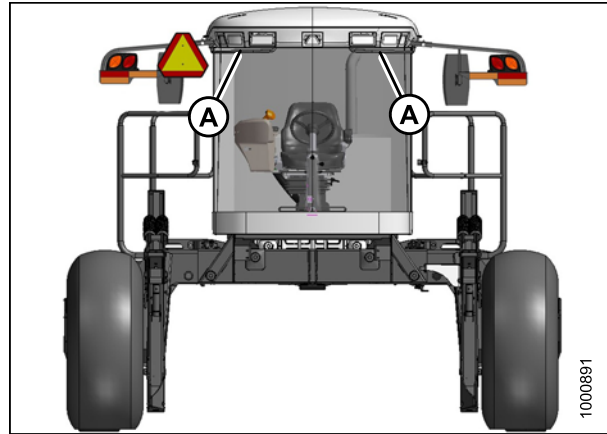

Figure 5.154: Cab Handholds

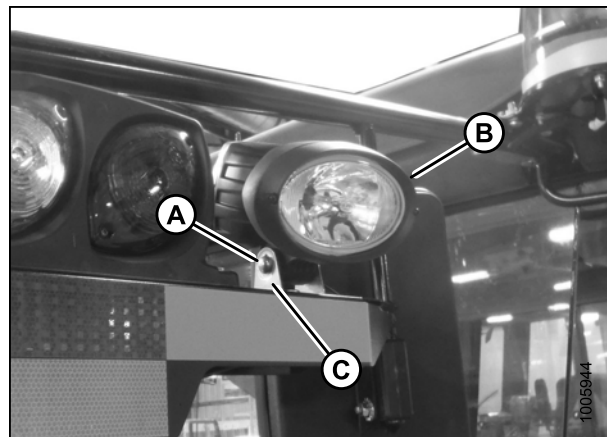

Figure 5.155: HID Auxiliary Lights

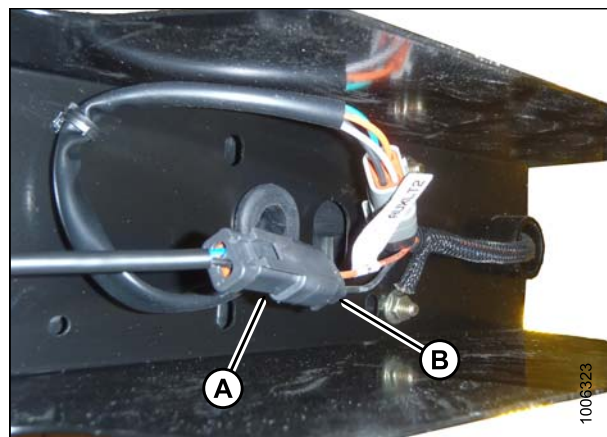

Figure 5.156: HID Auxiliary Light Harness

## MAINTENANCE AND SERVICING

2. Remove grommet (A) from light support (B).
3. Remove nut (C) and spring washer from inside light support (B).
4. Remove the lamp assembly.

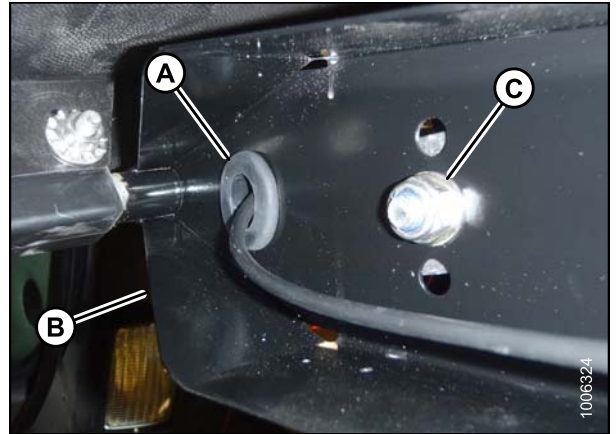

Figure 5.157: HID Light Assembly

5. Locate light in center hole in light support (B) and secure with hardware (C) provided with light assembly.
6. Adjust light assembly to desired position and tighten nut (C).
7. Route lamp harness through grommet (A) and slot in light support (B).
8. Reinstall grommet (A) in light support (B).

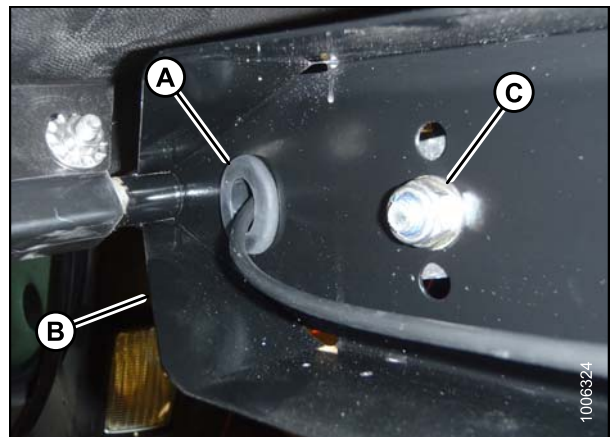

Figure 5.158: HID Light Assembly

9. Connect lamp plug (A) to main harness connector (B).

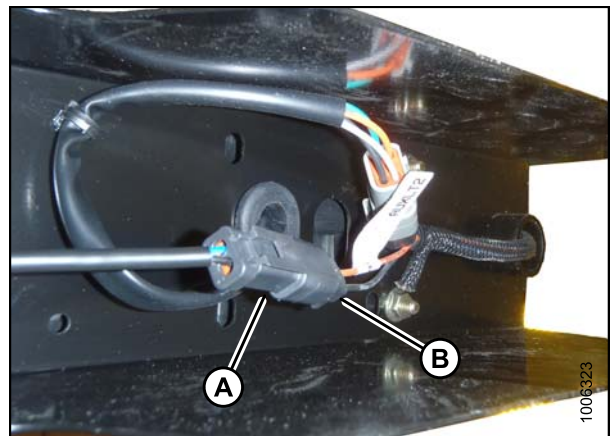

Figure 5.159: HID Auxiliary Light Harness

### *Adjusting High-Intensity Discharge (HID) Auxiliary Lights (if Installed)*

If installed, HID auxiliary lights are best adjusted with the machine in the field (or equivalent) to suit Operator preference.

#### **⚠ DANGER**

**To avoid bodily injury or death from unexpected startup of the machine, always stop the engine and remove the key from the ignition before leaving the operator's seat for any reason.**

1. Shut down engine and remove key. Turn lights ON.
2. Loosen bolt (A) and nut (B) (located inside light/mirror support).
3. Position light to desired position.
4. Tighten bolt (A) and nut (B).

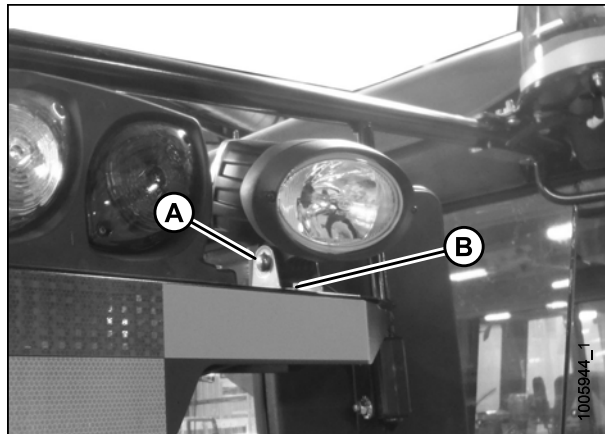

Figure 5.160: HID Auxiliary Lights

## 5.9.7 Flood Lights: Rear

### *Adjusting Rear Flood Lights*

The rear flood lights are best adjusted with the machine in the field (or equivalent) to suit Operator preference.

#### **⚠ DANGER**

**To avoid bodily injury or death from unexpected startup of the machine, always stop the engine and remove the key from the ignition before leaving the operator's seat for any reason.**

1. Shut down engine and remove key. Turn lights ON.
2. Loosen bolts (A) and (B).
3. Position light to desired position.
4. Tighten bolts (A) and (B).

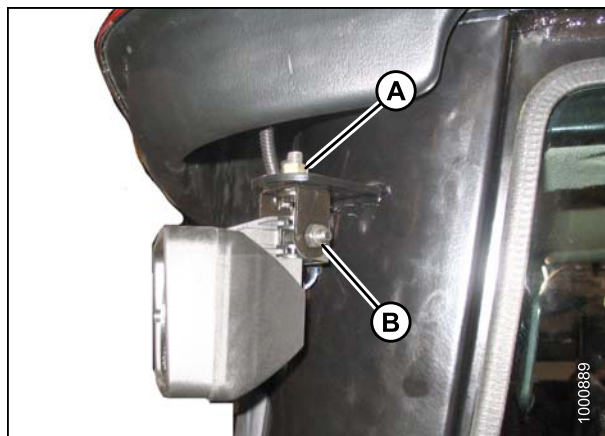

Figure 5.161: Rear Flood Light



*Replacing Bulb in Rear Flood Light*

**⚠ DANGER**

To avoid bodily injury or death from unexpected startup of the machine, always stop the engine and remove the key from the ignition before leaving the operator's seat for any reason.

1. Shut down engine and remove key. Turn lights OFF.
2. Remove two screws (A) and remove light bezel (B).
3. Remove light from receptacle.

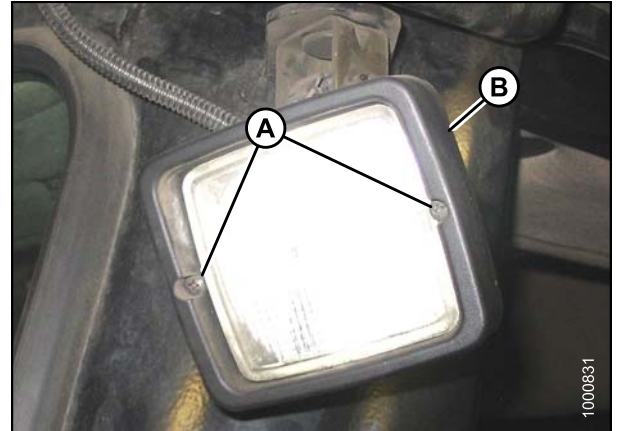

Figure 5.162: Rear Flood Light

**IMPORTANT:**

Do **NOT** touch the glass of the halogen bulb as the oils or other chemicals from your skin will cause the bulb to fail prematurely.

4. Pinch the wire retainer (A) and lift away from hooks.
5. Remove bulb (B) from body and pull wire from connector (D).
6. Match slots on new bulb (B) with lugs (C) in optical unit and insert bulb into unit.
7. Secure bulb with wire retainer (A).
8. Push wire into connector (D).

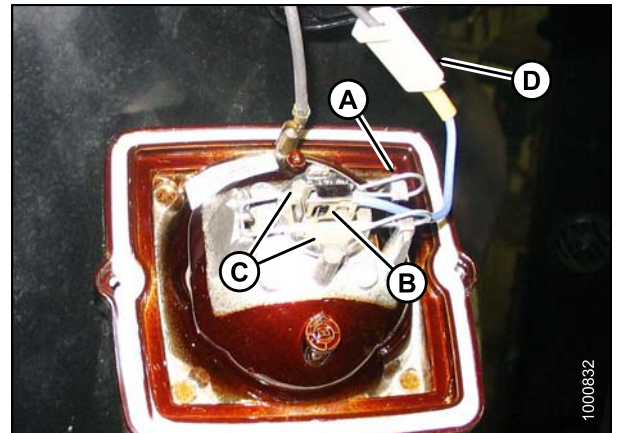

Figure 5.163: Rear Flood Light Assembly

## MAINTENANCE AND SERVICING

9. Position light into light receptacle, ensuring top is up.
10. Secure with bezel (B) and screws (A).

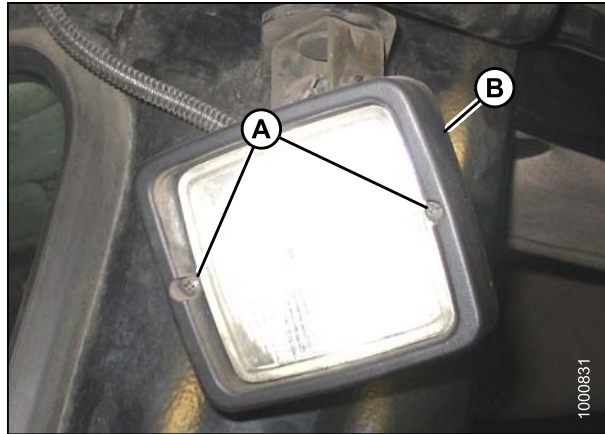

Figure 5.164: Rear Flood Light

### 5.9.8 Replacing Bulbs in Red and Amber Lights

To replace bulbs in red and amber lights, follow these steps:

#### DANGER

To avoid bodily injury or death from unexpected startup of the machine, always stop the engine and remove the key from the ignition before leaving the operator's seat for any reason.

1. Shut down engine and remove key. Turn lights OFF.

#### NOTE:

Hold onto the handholds (A) on the cab front corners and stand on the header anti-slip strips, or stand on the maintenance platform when accessing the red and amber lights.

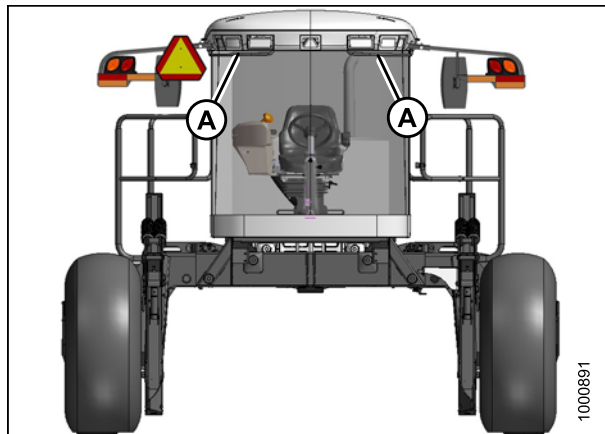

Figure 5.165: Cab Handholds

## MAINTENANCE AND SERVICING

2. Remove two screws (A) from lens and remove lens.
3. Push and twist light bulb to remove from socket.
4. Install new bulb in socket ensuring that bulb base is properly engaged in socket.
  - Use Bulb Trade #1157 for red tail lights
  - Use Bulb Trade #1156 for amber lights
5. Reinstall lens with screws (B).

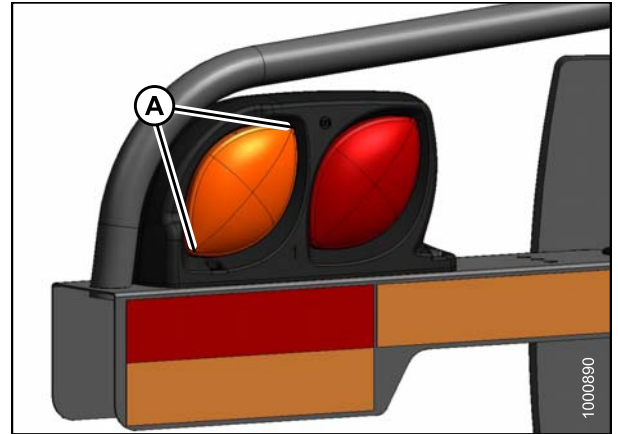

Figure 5.166: Red and Amber Lights

### 5.9.9 Replacing Red Tail Lights (if installed)

To replace the red tail lights, follow these steps:

#### DANGER

To avoid bodily injury or death from unexpected startup of the machine, always stop the engine and remove the key from the ignition before leaving the operator's seat for any reason.

1. Shut down engine and remove key. Turn lights OFF.
2. In the grill of the hood, remove two screws (A) from light (B), and remove light.
3. Remove connector from light.
4. Connect wiring harness to new light (B) and install light with screws (A).

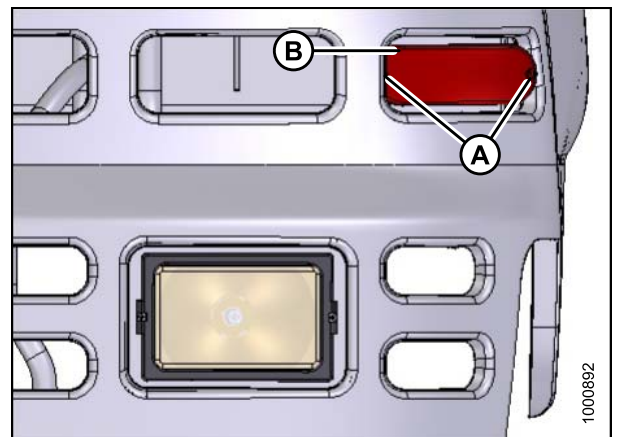

Figure 5.167: Red Tail Lights

### 5.9.10 Replacing the Bulbs in Beacon Lights

#### DANGER

To avoid bodily injury or death from unexpected startup of the machine, always stop the engine and remove the key from the ignition before leaving the operator's seat for any reason.

## MAINTENANCE AND SERVICING

To replace the halogen bulb inside the beacon warning lights, follow these steps:

1. Shut down engine and remove key. Turn beacons OFF.

**NOTE:**

Hold onto the handholds (B) on the cab front corners and stand on the header anti-slip strips, or stand on the maintenance platform when accessing the beacons (A).

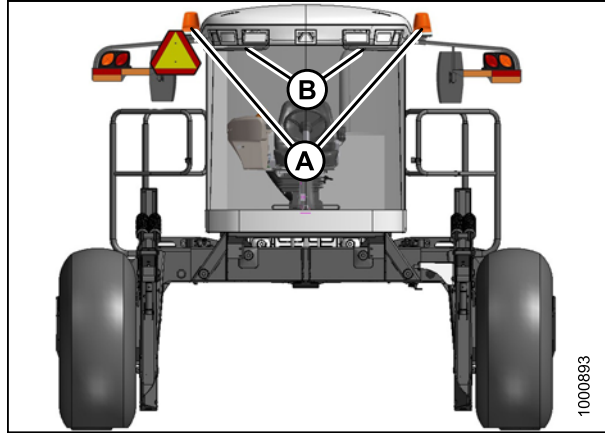

Figure 5.168: Warning Beacons

2. Turn lens (A) counterclockwise to unlock lens from base and remove lens.

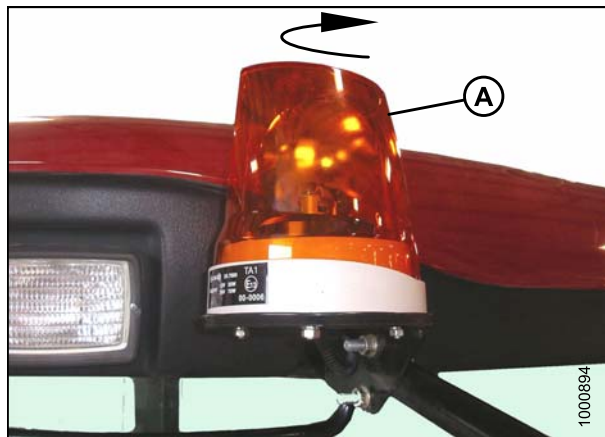

Figure 5.169: Warning Beacon

3. Pinch retainer (A) and remove it from lamp socket.
4. Pull lamp out of socket.



Figure 5.170: Beacon Lamp Assembly

## MAINTENANCE AND SERVICING

5. Disconnect harness from lamp.

**IMPORTANT:**

Do **NOT** touch the glass (A) of the halogen bulb as the oils or other chemicals from your skin will cause the bulb to fail prematurely.



Figure 5.171: Beacon Lamp Assembly

6. Connect harness to new lamp, place lamp in socket, and line up the flat side on lamp with recess in socket.



Figure 5.172: Beacon Lamp Assembly

## MAINTENANCE AND SERVICING

- Place retainer (A) over lamp and pinch tabs to secure retainer to socket.



Figure 5.173: Beacon Lamp Assembly

- Line up the three lugs (one is longer) in the base with slots in lens, and seat the lens against the rubber seal.



Figure 5.174: Beacon Lamp Assembly

## MAINTENANCE AND SERVICING

9. Turn the lens clockwise to lock it in place.

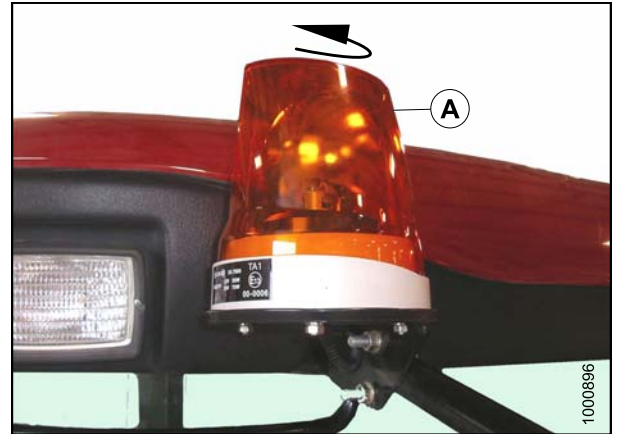

Figure 5.175: Warning Beacon

### 5.9.11 Replacing the Cabin Dome Light

To replace a cabin dome light, follow these steps:

1. Shut down engine.
2. Remove two screws (A) from the dome light assembly and remove the assembly.
3. Disconnect the old dome light assembly from the wiring harness.
4. Connect the new dome light (MD #183413) to the wiring harness.
5. Install the new dome light with two screws (A).

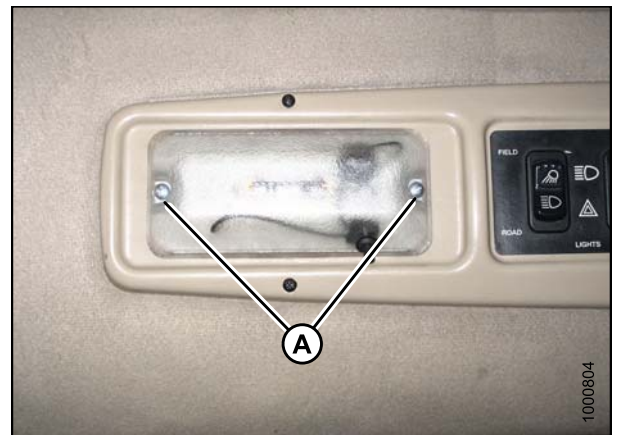

Figure 5.176: Cabin Dome Light

## 5.9.12 Replacing the Ambient Light Fixture

To replace the ambient light fixture, follow these steps:

1. Shut down engine.
2. Locate the ambient light fixture (A) in the roof liner.
3. Push against tabs (A) with a screwdriver and pull ambient light fixture out of cab roof.
4. Remove wires from connectors (B).
5. Connect wires to new light fixture.
6. Push into place in cab roof until tabs hold fixture in place.



Figure 5.177: Ambient Light Fixture

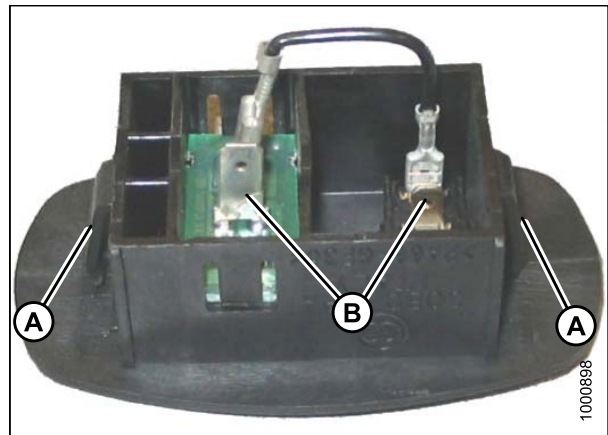

Figure 5.178: Ambient Light Fixture



### 5.9.13 Turn Signal Indicators

If the turn signal indicators on the cab display module (CDM) do not function, contact your MacDon Dealer.

### 5.9.14 Accessing Circuit Breakers and Fuses

The circuit breakers and fuses are located inside a fuse box mounted on the right (cab-forward) side of the frame under the platform.

The circuit breakers automatically reset. Fuses are the plastic blade type.

#### DANGER

**To avoid bodily injury or death from unexpected startup of the machine, always stop the engine and remove the key from the ignition before leaving the operator's seat for any reason.**

Access the breakers and fuses as follows:

1. Stop engine and remove key.
2. Move right (cab-forward) side platform rearward. Refer to [5.3.1 Opening Platforms \(Standard Position\)](#), page 287.
3. Remove wing nut (A) and remove fuse box cover (B).
4. Refer to the decal on inside of cover for identification of fuses and circuit breakers.
5. A cover may be installed over the circuit breaker. Remove it to access the breaker.

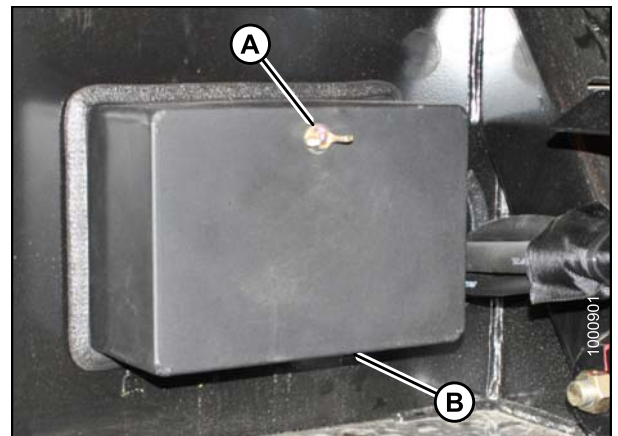

Figure 5.179: Fuse Box

#### Checking and Replacing Fuses

1. To check fuse, pull fuse (A) out of receptacle and visually examine.
2. To replace fuse, insert new fuse into receptacle.

#### IMPORTANT:

Replacement fuses should match rating on decal shown on [Fuse Box Decal](#), page 383.

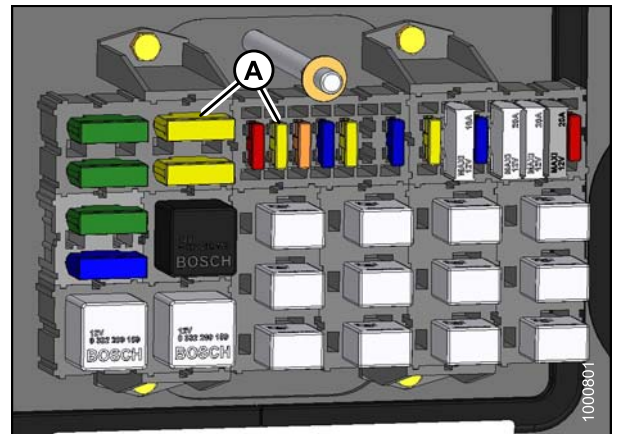

Figure 5.180: Fuses

## MAINTENANCE AND SERVICING

### Replacing Circuit Breakers and Relays

#### DANGER

To avoid bodily injury or death from unexpected startup of the machine, always stop the engine and remove the key from the ignition before leaving the operator's seat for any reason.

Replace breakers and relays as follows:

1. Stop engine and remove key.
2. Move right cab-forward side platform rearward (cab-forward).
3. To replace circuit breaker (A), pull breaker out of receptacle and install new circuit breaker.
4. To replace relay (B), pull relay out of receptacle and install new relay.
5. Reinstall cover and secure with wing nut.

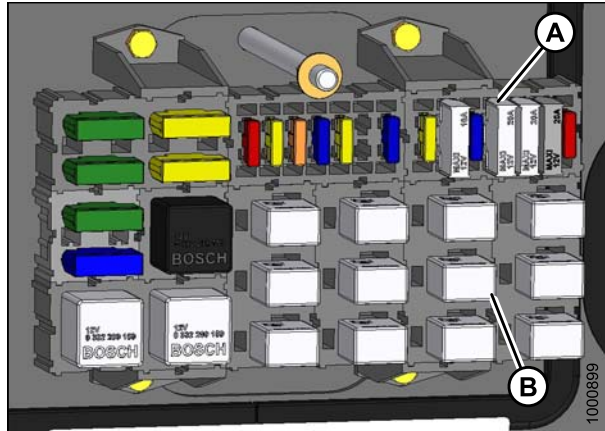

Figure 5.181: Relays and Breakers

# MAINTENANCE AND SERVICING

## Fuse Box Decal

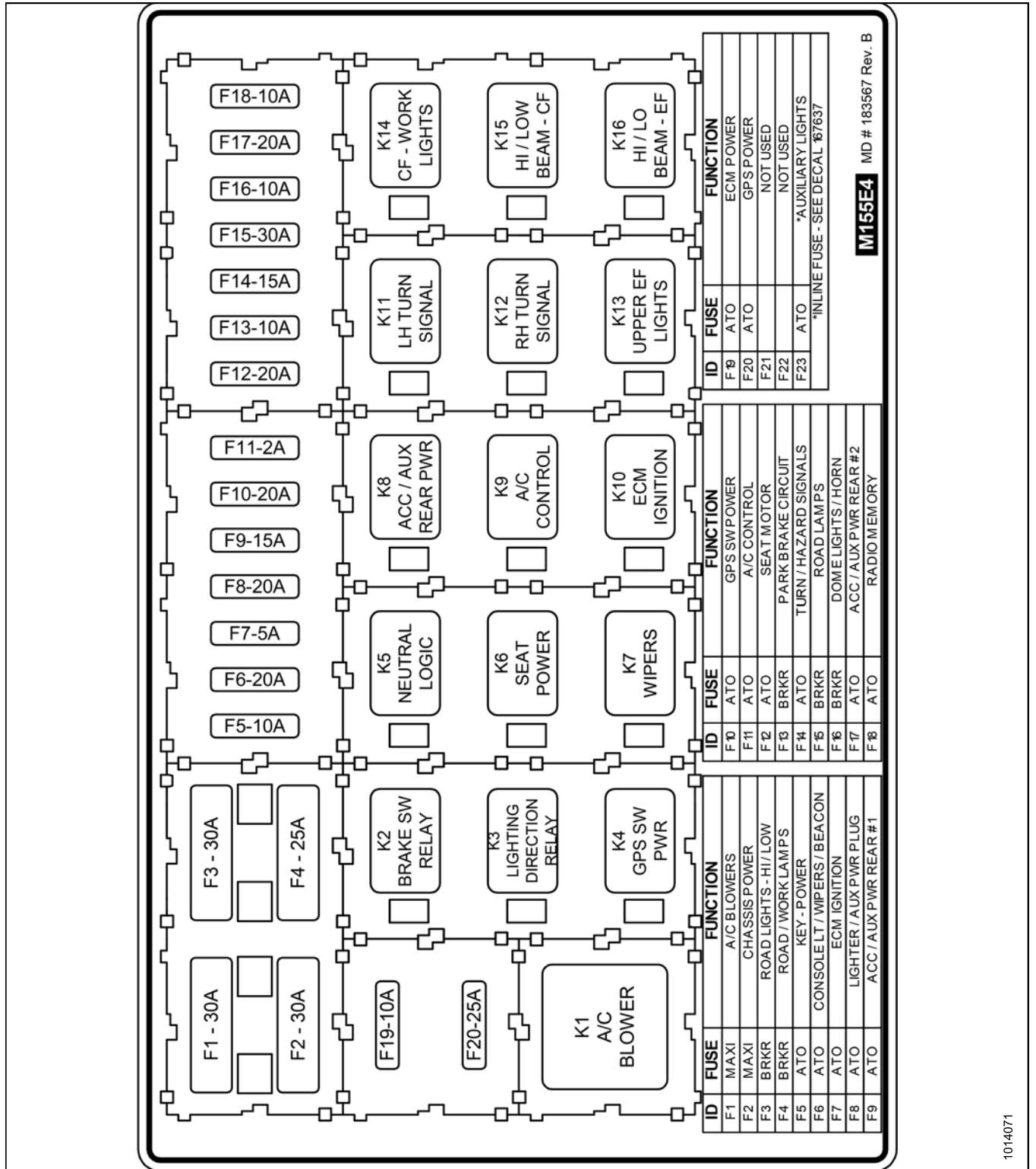

Figure 5.182: Fuse Decal

1014071

### Accessing T4 Specific Fuses

The M155E4 carries a separate fuse and breaker box and an electronic control unit (ECU) power fuse dedicated to the diesel exhaust fluid (DEF) system.

The fuse box (A) and the electronic control unit (ECU) power fuse (B) are located below the exhaust canister on the right cab-forward side and secured above the side frame.

#### **⚠ DANGER**

To avoid bodily injury or death from unexpected startup of machine, always stop engine and remove key from ignition before leaving operator's seat for any reason.

Access the breakers and fuses as follows:

1. Stop engine and remove key.
2. Move right cab-forward side platform rearward (cab-forward). Refer to [5.3.3 Opening Platforms \(Major Service Position\)](#), page 289.
3. Raise hood to the highest position. Refer to [5.2.3 Opening Hood \(Highest Position\)](#), page 285.
4. Undo clips (A) on both sides of the fuse and breaker box.
5. Remove cover (B).

#### **NOTE:**

Refer to the decal on inside of cover for identification of fuses and relays.

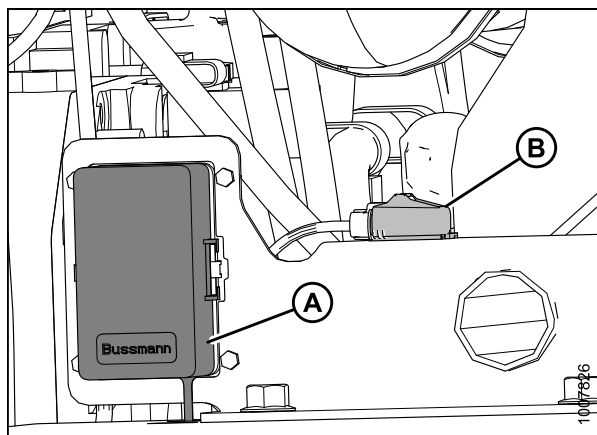

**Figure 5.183: Fuse Box and ECU Power Fuse**

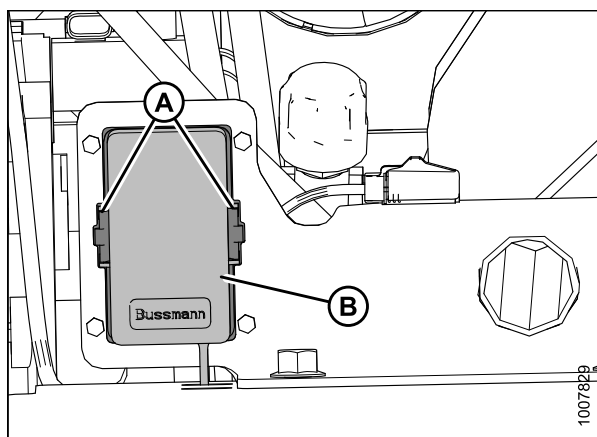

**Figure 5.184: Fuse Box**

## MAINTENANCE AND SERVICING

6. Undo clip (A) on the ECU power fuse and pull cover (B) away.

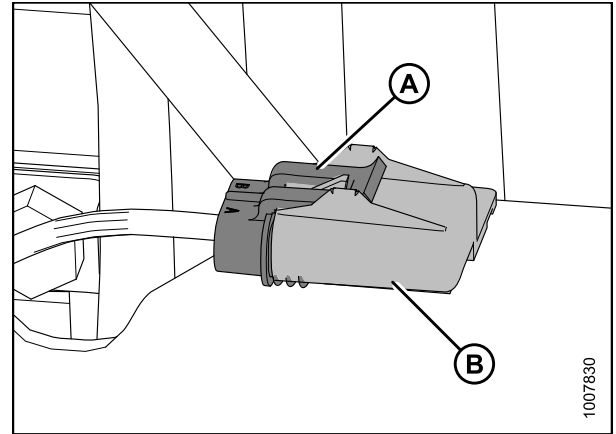

**Figure 5.185: ECU Power Fuse**

### Checking and Replacing T4 Specific Fuses and Relays

1. **To Check and Replace Fuse**
  - a. Pull fuse out of receptacle and visually examine.
  - b. To replace fuse, insert new fuse into receptacle.
2. **To Replace Relay**
  - a. Pull relay out of receptacle and install new relay.

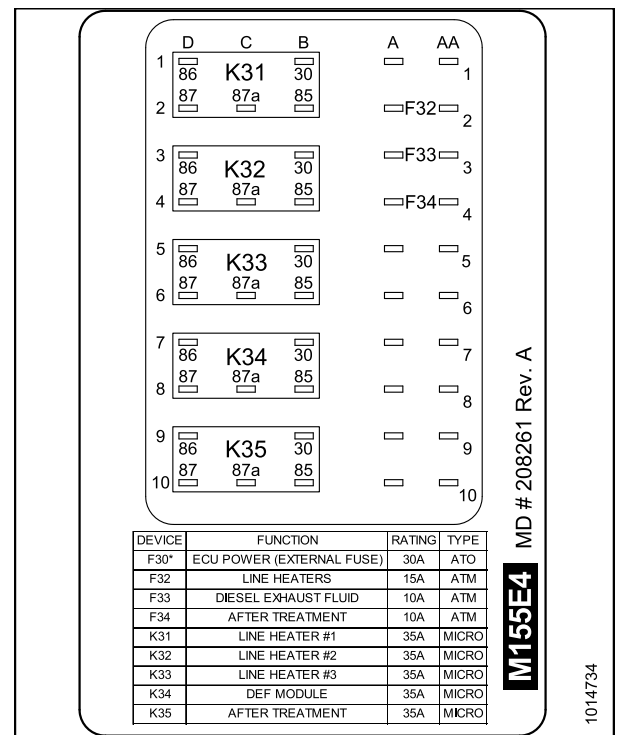

**Figure 5.186: Fuses and Relays**

### Inspecting and Replacing 125A Main Fuses

The 125A main fuse holders are located on the frame under the right cab-forward side platform beside the battery.

Access the 125A main fuses as follows:



**To avoid bodily injury or death from unexpected startup of the machine, always stop the engine and remove the key from the ignition before leaving the operator's seat for any reason.**

## MAINTENANCE AND SERVICING

1. Stop engine and remove key.
2. Move right (cab-forward) side platform rearward.

**NOTE:**

There are three main fuses, two (A) are secured on the right cab-forward front frame and one is behind the frame secured by the two bolts and nuts (B).

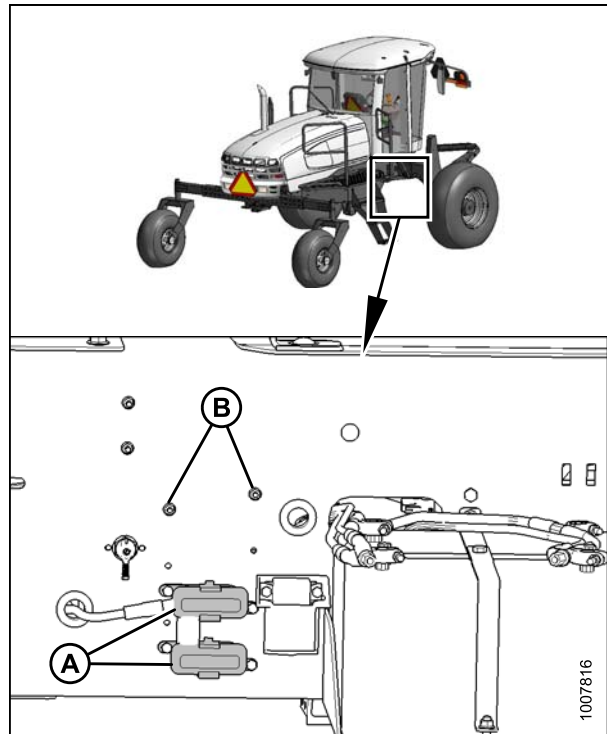

**Figure 5.187: 125A Main Fuses**

3. To check condition of fuse, pull tab (A) and open cover (B).

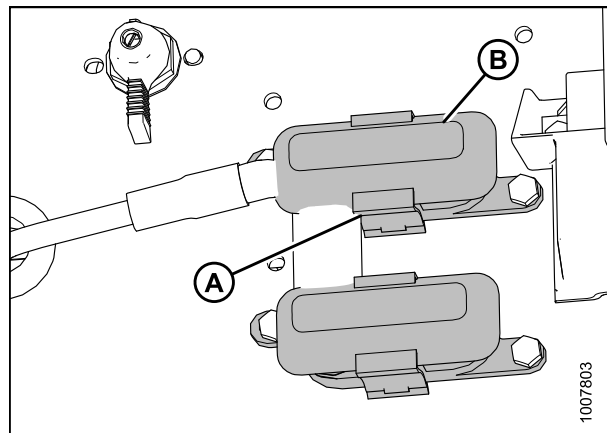

**Figure 5.188: 125A Main Fuses**

## MAINTENANCE AND SERVICING

4. Visually examine fuse (B) for indications of melting.
5. Remove fuse (B), remove two nuts (C) and pull fuse free from holder (existing wiring may need to be pulled off the stud first).
6. Install new fuse on studs and any existing wiring that was removed.
7. Secure with nuts (C).

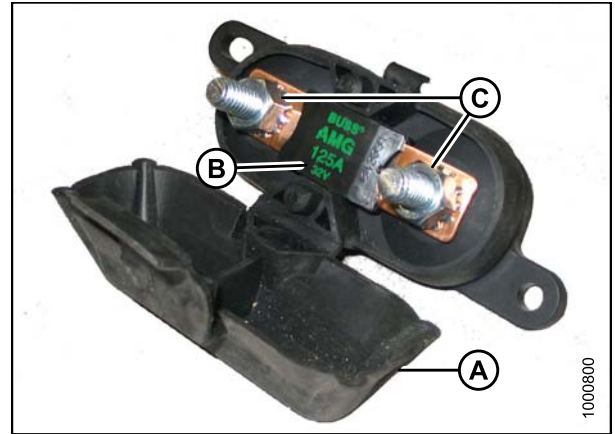

Figure 5.189: 125A Main Fuse

8. Close cover (B) and secure with tab (A).
9. Return platform to operating position. Ensure lock engages.

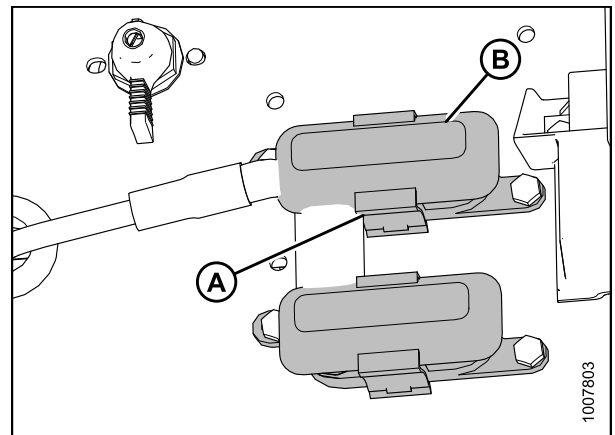

Figure 5.190: 125A Main Fuses

## 5.10 Hydraulic System

The M155E4 windrower hydraulic system provides oil pressure for the windrower drive system, the header lift, and header drive systems.

### WARNING

- Avoid high pressure fluids. Escaping fluid can penetrate the skin causing serious injury. Relieve pressure before disconnecting hydraulic lines.
- Tighten all connections before applying pressure. Keep hands and body away from pin-holes and nozzles which eject fluids under high pressure.



Figure 5.191: Hydraulic Pressure Hazard

### WARNING

- Use a piece of cardboard or paper to search for leaks.
- If ANY fluid is injected into the skin, it must be surgically removed within a few hours by a Doctor familiar with this type of injury or gangrene may result.

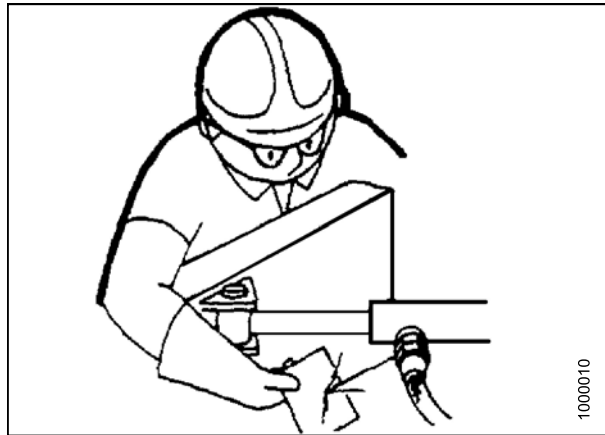

Figure 5.192: Checking Hydraulic Leaks

### IMPORTANT:

Foreign material such as dirt, dust, and water is the major cause of trouble in the hydraulic system.

If hydraulic system components must be disconnected for service, protect the ends of hoses, tubing, and ports of components from contamination with clean, lint-free towels, or clean plastic bags.

Before installing any replacement hose, flush the inside with unused diesel fuel or unused commercial petroleum cleaning solvent for ten seconds minimum. Do **NOT** use water, water soluble cleaners, or compressed air.

The hydraulic system components are built to very close tolerances and have been adjusted at the factory. Do **NOT** attempt to service these components except to maintain proper oil level, change oil and filters, and to adjust relief pressures as described in this manual.

See your MacDon Dealer for all other service.



### 5.10.1 Checking and Filling Hydraulic Oil

#### DANGER

To avoid bodily injury or death from unexpected startup of the machine, always stop the engine and remove the key from the ignition before leaving the operator's seat for any reason.

1. Park windrower on level ground and lower header and reel so that lift cylinders are fully retracted.
2. Stop the engine and remove the key.
3. Open the hood. Refer to [5.2.1 Opening Hood \(Lower Position\)](#), page 284.

**NOTE:**

A sight glass (A) is provided under the hood on the right side of the tank. It indicates oil level and signs of contamination. No oil in the sight glass indicates oil level is below the add mark on the dipstick.

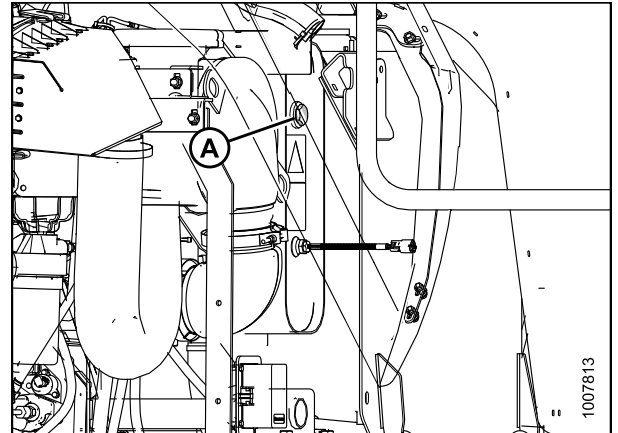

**Figure 5.193: Hydraulic Oil Sight Glass**

4. Stand on left (cab-forward side) platform to access the filler pipe.
5. Clean cap (A) and surrounding area.
6. Turn filler cap (A) counterclockwise to unlock cap and remove dipstick.

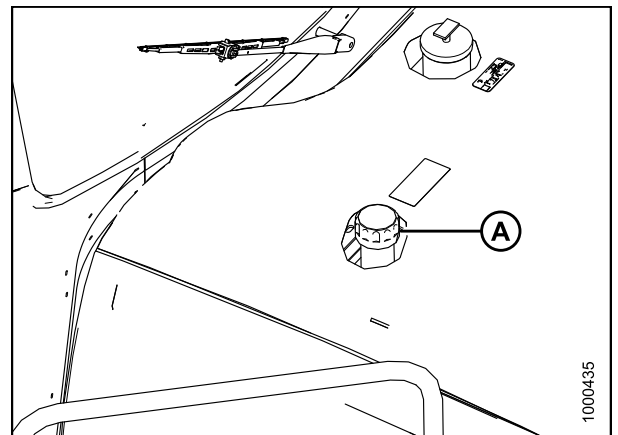

**Figure 5.194: M155E4 Engine Hood**

## MAINTENANCE AND SERVICING

7. If necessary, add oil to maintain a level between the low (L) and full (H) marks. Refer to [8.1.3 Lubricants, Fluids, and System Capacities, page 444](#) for hydraulic oil specifications and quantity.

**NOTE:**

When dipstick is showing low (L), approximately 1 US gallon (4 liters) is required to reach the full (H) mark.

**IMPORTANT:**

- Use new, good quality, prefiltered clean oil
  - Exercise care to prevent debris from falling into tank
8. Reinstall dipstick and filler cap, and turn clockwise to tighten/lock.
  9. Close the hood. Refer to [5.2.2 Closing Hood \(Lower Position\), page 285](#).

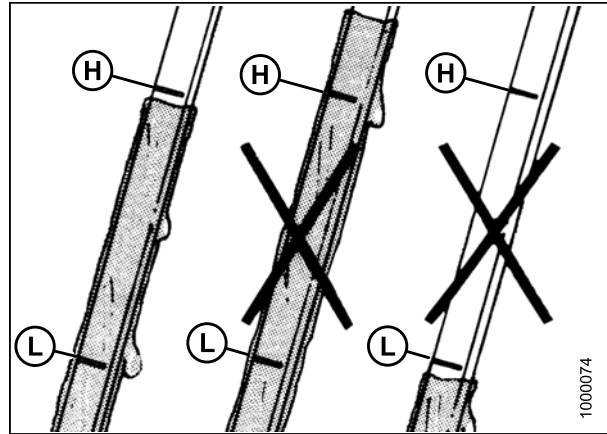

**Figure 5.195: Hydraulic Oil Levels**

### 5.10.2 Hydraulic Oil Cooler

The hydraulic oil cooler is located inside the cooling box behind the radiator.

It should be cleaned daily with compressed air. Refer to [5.8.3 Cleaning Cooler Box Components, page 350](#).

### 5.10.3 Draining Hydraulic Oil

To drain hydraulic oil, follow these steps:

Hydraulic oil should be changed every 1500 hours or every 2 years.

**⚠ DANGER**

To avoid bodily injury or death from unexpected startup of the machine, always stop the engine and remove the key from the ignition before leaving the operator's seat for any reason.

1. Park the windrower on level ground, and lower the header and reel so that the lift cylinders are fully retracted.
2. Stop the engine and remove the key.
3. Open the hood. Refer to [5.2.3 Opening Hood \(Highest Position\)](#), page 285.
4. Place a clean container (at least 20 US gallons [75 liters]) under drain at the bottom of the hydraulic reservoir to collect the oil.
5. Remove drain plug (A) and allow oil to drain.
6. Inspect particles and clean off any metal debris that may have accumulated on magnetic plug. Wipe plug with a clean cloth. Check O-ring condition. Look for cracking, breakage, or deformation that may impede sealing ability and replace as required.
7. Install drain plug (A), torque 59 ft·lbf (80 N·m).
8. Fill hydraulic oil reservoir. Refer to [5.10.1 Checking and Filling Hydraulic Oil](#), page 389.

### 5.10.4 Changing Hydraulic Oil Filters

Change hydraulic oil filters after the first 50 hours of operation, and every 500 hours thereafter. Filter (A) (MD #112419) and filter (B) (MD #151975) can be obtained from your Dealer.

The charge oil filter (A) and return oil filter (B) are located just inside the frame on the left side and are accessible from under the windrower.

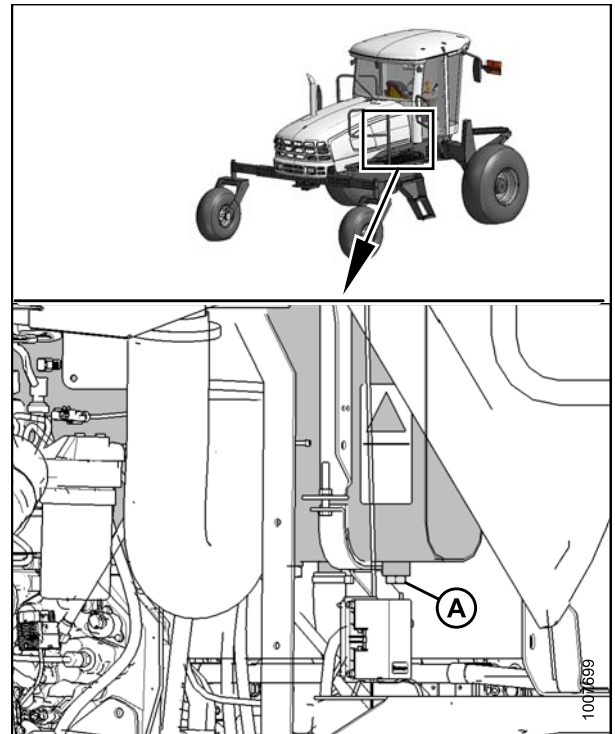

**Figure 5.196: Hydraulic Oil Drain Plug (Parts Removed for Clarity)**

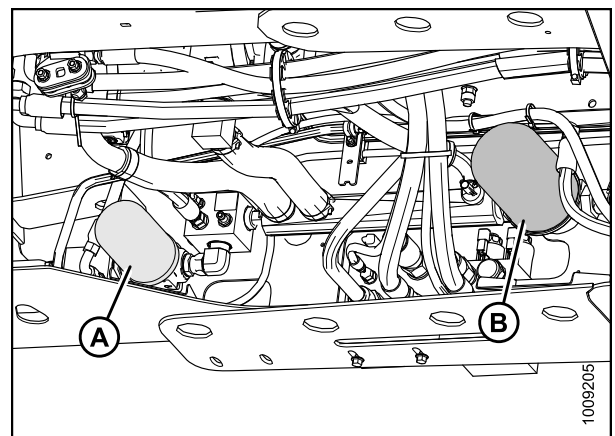

**Figure 5.197: Hydraulic Oil Filters**

### Charge Oil Filter

The charge oil filter filters the oil in the windrower hydraulic charge circuit that supplies make up oil for normal losses at motor and pump case drains and associated circuits.

#### Removing Charge Oil Filter

### DANGER

To avoid bodily injury or death from unexpected startup of the machine, always stop the engine and remove the key from the ignition before leaving the operator's seat for any reason.

1. Stop the engine and remove the key.
2. Clean around head of the filter.
3. Place a container beneath the filter to collect any oil that may leak out.
4. Unscrew filter (A) with a filter wrench.
5. Dispose of used oil and filter in accordance with local environmental legislation.

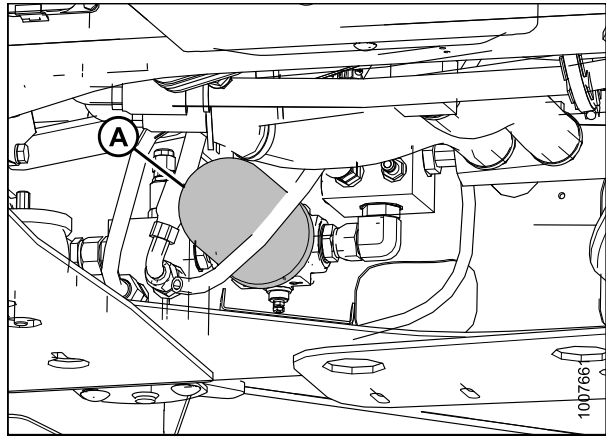

Figure 5.198: Charge Oil Filter

#### Installing Charge Oil Filter

### NOTE:

For charge oil filter replacement part number, refer to [8.1.4 Filter Part Numbers, page 445](#).

1. Clean the gasket surface of the filter head.
2. Apply a thin film of clean oil to the filter gasket.
3. Screw the new filter (A) onto the mount until the gasket contacts the filter head.
4. Tighten filter an additional 1/2 turn by hand.

### IMPORTANT:

Do **NOT** use a filter wrench to install oil filter. Overtightening can damage gasket and filter.

5. Check hydraulic fluid levels. Refer to [5.10.1 Checking and Filling Hydraulic Oil, page 389](#). For capacity level, refer to [8.1.3 Lubricants, Fluids, and System Capacities, page 444](#).

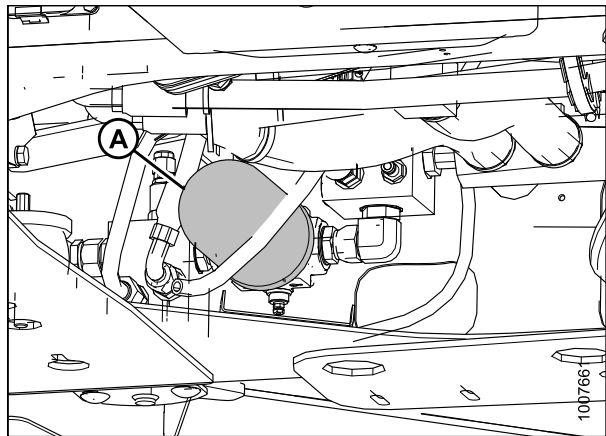

Figure 5.199: Charge Oil Filter

### Return Oil Filter

The return oil filter filters the oil in the header drive systems and should be changed after the first 50 hours and then at 500 hour intervals.

#### Removing Return Oil Filter



**To avoid bodily injury or death from unexpected startup of the machine, always stop the engine and remove the key from the ignition before leaving the operator's seat for any reason.**

1. Stop the engine and remove the key.
2. Clean around head of the filter (A).
3. Place a container beneath the filter (A) to collect any oil that may leak out.
4. Unscrew filter (A) with a filter wrench.
5. Dispose of used oil and filter in accordance with local environmental legislation.

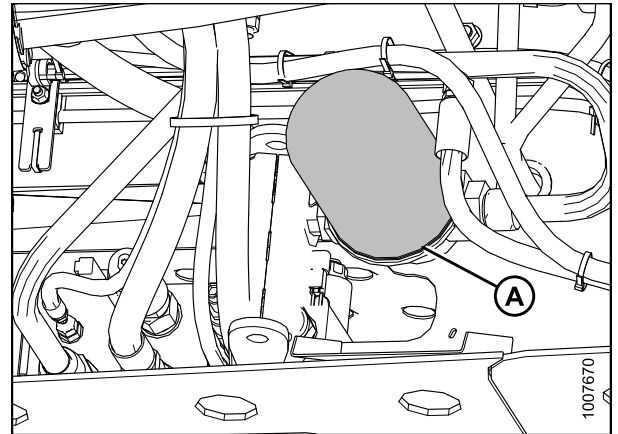

Figure 5.200: Return Oil Filter

**NOTE:**

Image showing filter head removed to show component clarity.

6. Remove gasket (C) from groove (B) in filter head (A). Filter (D) shown for context.

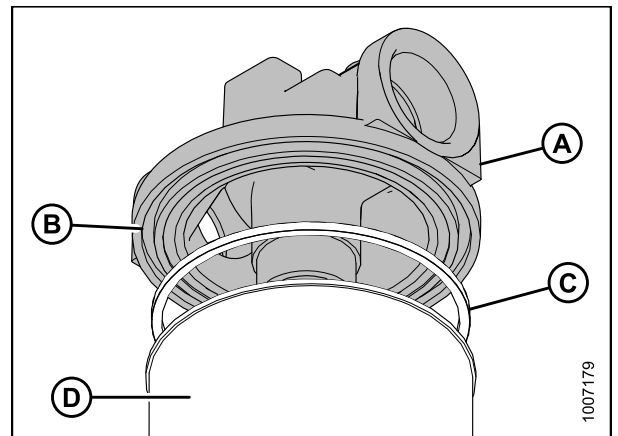

Figure 5.201: Return Oil Filter

#### Installing Return Oil Filter

**NOTE:**

For filter specifications, refer to [8.1.4 Filter Part Numbers, page 445](#).

## MAINTENANCE AND SERVICING

1. Clean the gasket groove (B) in the filter head (A).
2. Apply a thin film of clean oil to the filter gasket (C).
3. Install new gasket (C) into the groove (B) in the filter head (A).
4. Screw the new filter (D) onto the filter head until the gasket contacts the filter.

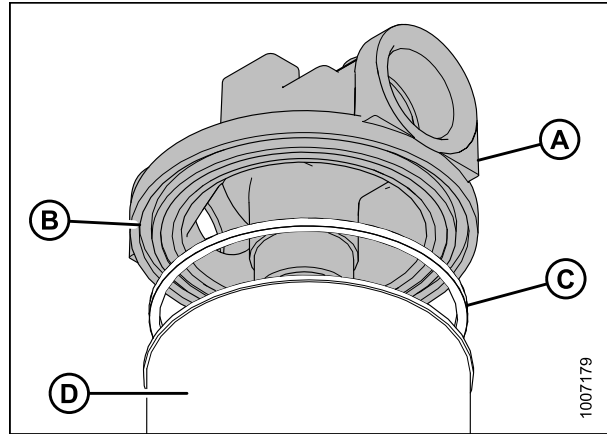

Figure 5.202: Return Oil Filter

5. Tighten filter (A) an additional 3/4 turn by hand.

### IMPORTANT:

Do **NOT** use a filter wrench to install oil filter. Overtightening can damage gasket and filter.

6. Check hydraulic fluid levels. Refer to [5.10.1 Checking and Filling Hydraulic Oil, page 389](#). For capacity level, refer to [8.1.3 Lubricants, Fluids, and System Capacities, page 444](#).

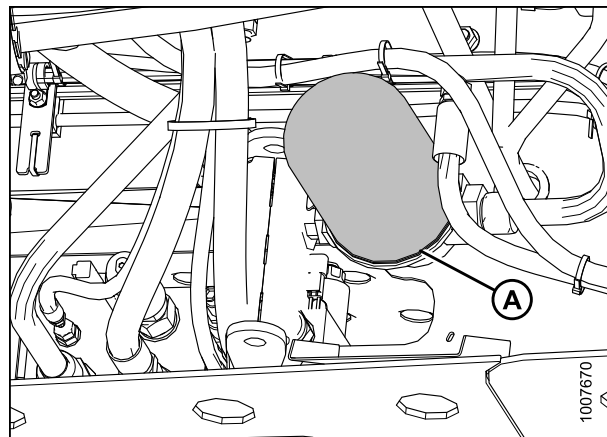

Figure 5.203: Return Oil Filter

## 5.10.5 Header and Reel Hydraulics

### Pressure Compensator Valve

The pressure compensator valve protects the header drive pumps from overheating under very heavy loads.

When the operating pressure reaches the absolute pressure limit setting (refer to [5.3 Header Hydraulic Pressures, page 395](#)) the compensator valve in the pump is activated and the header drive will slow down to avoid overheating the drive pumps. At this point, reduce the ground speed to maintain the correct system load and header drive operation.

### NOTE:

An optional pressure sensor is available to monitor the knife or reel drive hydraulic pressure and provide a warning tone from the cab display module (CDM) if the system pressure approaches a preset limit. The system pressure limit is set during CDM programming. Refer to [6.2.10 Pressure Sensor Kit, page 421](#).

### NOTE:

The warning tone is only heard if the pressure sensor is installed and enabled.

### NOTE:

A warning tone is normal when the operating pressure is close to the compensator valve's pressure setting.

## MAINTENANCE AND SERVICING

**Table 5.3 Header Hydraulic Pressures**

Header Model	Application/System	Windrower Absolute Pressure Limit Setting psi (kPa)	Suggested Overload Warning Setting psi (kPa)
R-Series	Disc pressure	4200 (28,958)	4000 (27,579)
D-Series A-Series	Reel/drapper pressure	3200 (22,063)	3000 (20,684)
	Knife/conditioner pressure	4200 (28,958)	4000 (27,579)

If lift and drive capacity problems develop, the pressure compensator valve may require adjusting. Contact your MacDon Dealer for assistance.

### *Flow Control Blocks*

Two hydraulic valve blocks with multiple cartridges are used for the various windrower functions and are controlled by the windrower control module (WCM) according to the inputs from the Operator. The valve blocks are located behind the left cab-forward side platform.

The valve blocks do not require any scheduled maintenance other than to check for leaking fittings or loose electrical connections. If service is required, contact your MacDon Dealer.

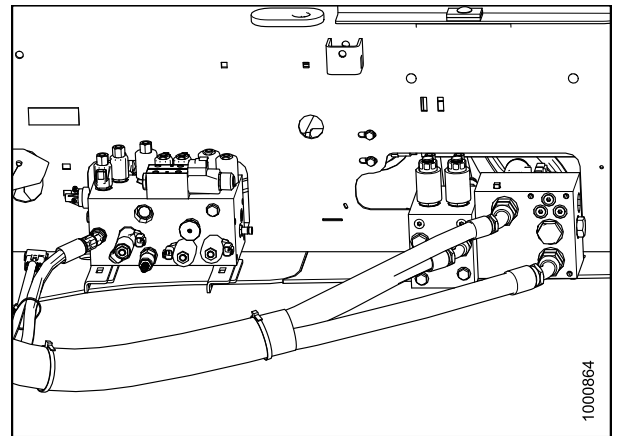

**Figure 5.204: Hydraulic Valve Blocks**

### *Adjusting Header Drop Rate*

The header should lower gradually when the lower header switch is pressed. From fully raised to ground position, it should take approximately three to four seconds.

**NOTE:**

Drop rate should **NOT** be less than three to four seconds as structural damage may result.

**NOTE:**

If drop rate is too slow (over 30 seconds), return to cut height or tilt or float presets will deactivate to prevent overheating the hydraulic system.

** DANGER**

**To avoid bodily injury or death from unexpected startup of the machine, always stop the engine and remove the key from the ignition before leaving the operator's seat for any reason.**

1. Lower header to ground, stop the engine, and remove the key.
2. Open left cab-forward side platform. Refer to [5.3.1 Opening Platforms \(Standard Position\), page 287](#).

## MAINTENANCE AND SERVICING

3. Loosen inner knob (B) on needle valve and then turn outer knob (A):
  - Clockwise to decrease the drop rate
  - Counterclockwise to increase the drop rate
4. Tighten inner knob (A).
5. Check drop rate and readjust, as required.
6. Close the platform. Refer to [5.3.2 Closing Platforms \(Standard Position\)](#), page 288.

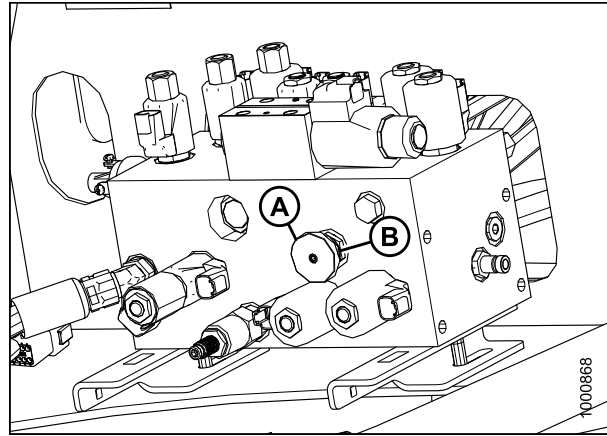

Figure 5.205: Multifunction Block

### *Adjusting Reel Drop Rate*

The reel should lower gradually when the lower reel switch is pressed. From fully raised to fully lowered should take approximately three to four seconds. Drop rate is a customer preference and will vary based on crop type and cutting condition.

#### **NOTE:**

Drop speed should **NOT** be less than three to four seconds as structural damage may result.

### **⚠ DANGER**

**To avoid bodily injury or death from unexpected startup of the machine, always stop the engine and remove the key from the ignition before leaving the operator's seat for any reason.**

1. Lower header to ground, stop the engine, and remove the key.
2. Open the left cab-forward side maintenance platform. Refer to [5.3.1 Opening Platforms \(Standard Position\)](#), page 287.



## MAINTENANCE AND SERVICING

3. Locate valve (A) installed at port D, it controls the reel drop rate.

**NOTE:**

This valve is installed on draper-ready windrowers and only affects draper headers.

4. Loosen setscrew (B), then refer to the following options:
  - Turn cap (C) clockwise to decrease the drop rate
  - Turn cap (C) counterclockwise to increase the drop rate
5. Check drop rate and adjust, as required.
6. Tighten setscrew (B).

**NOTE:**

To reset to factory specifications, fully close the needle valve and open it four turns counterclockwise.

7. Close the platform. Refer to [5.3.2 Closing Platforms \(Standard Position\)](#), page 288.

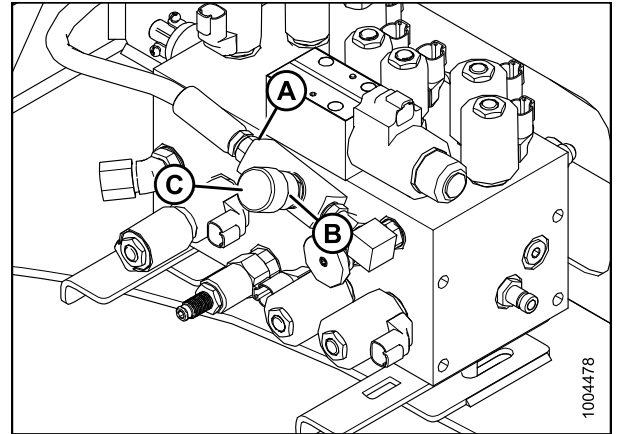

**Figure 5.206: Lift Manifold Valve**

### 5.10.6 Traction Drive Hydraulics

The windrower transmission consists of two variable displacement axial piston hydraulic pumps, one for each drive wheel.

The pumps are driven through a gearbox from the engine. Each pump requires charge flow in order to

- Make up for internal leakage
- Maintain positive pressure in the main circuit
- Provide flow for cooling
- Replace any leakage losses from external valving or auxiliary systems

The charge pressure is monitored. The cab display module (CDM) sounds a tone and displays a flashing warning if charge pressure drops below 250 psi (1725 kPa). Refer to [Display Warnings and Alarms](#), page 90.

#### *Checking Transmission Oil Pressure*

**IMPORTANT:**

Rated charge pressure **MUST** be maintained under all conditions of operation to prevent damage to the transmission.

If the TRANS OIL PRESSURE warning is displayed, shut down engine, and proceed as follows:

1. Check the hydraulic fluid level in the tank. Refer to [5.10.1 Checking and Filling Hydraulic Oil](#), page 389.
2. Check the hoses and lines for leakage.
3. Check the charge pressure relief valve. Refer to [Checking Charge Pump Pressure](#), page 398.
4. If charge pressure still cannot be maintained, do **NOT** operate the windrower. Contact your MacDon Dealer.

## MAINTENANCE AND SERVICING

### Checking Charge Pump Pressure

#### DANGER

To avoid bodily injury or death from unexpected startup of the machine, always stop the engine and remove the key from the ignition before leaving the operator's seat for any reason.

Incorrect charge pressure settings may result in the inability to build required system pressure and/or inadequate loop flushing flows.

Correct charge pressure **MUST** be maintained under all conditions to maintain pump control performance and to operate the brake release.

Check charge pump pressure as follows:

1. Open hood fully. Refer to [5.2.3 Opening Hood \(Highest Position\)](#), page 285.
2. Attach a 0–600 psi (4000 kPa) pressure gauge to a hose that is long enough to allow pressure gauge to be read from the operator's seat.
3. Locate the test port (A) on the charge filter head. Clean test port fitting and attach hose to the fitting.
4. Start engine and leave at idle. Pressure should be 240–325 psi (1655–2241 kPa) with the hydraulic oil at 100°F (40°C) minimum.
5. Note reading and shut down windrower.
6. If pressure is **NOT** within this range, contact your MacDon Dealer.
7. If pressure is within range, remove hose from test port and close the hood. Refer to [5.2.4 Closing Hood \(Highest Position\)](#), page 286.

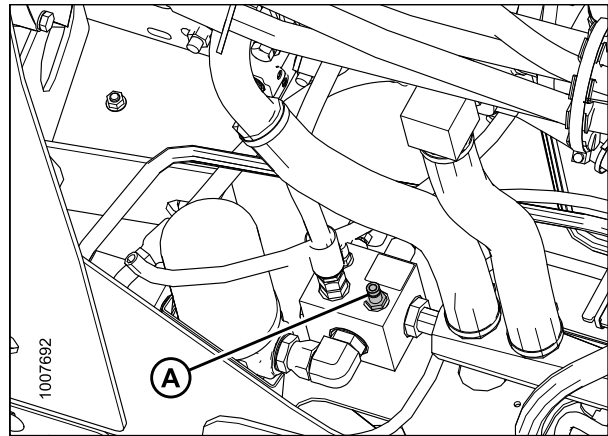

Figure 5.207: Charge Pump Test Port

### 5.10.7 Hoses and Lines

Check hydraulic hoses and lines daily for signs of leaks.

#### WARNING

- Avoid high-pressure fluids. Escaping fluid can penetrate the skin causing serious injury.
- Relieve pressure before disconnecting hydraulic lines. Tighten all connections before applying pressure.
- Keep hands and body away from pin-holes and nozzles which eject fluids under high pressure.
- If ANY fluid is injected into the skin, it must be surgically removed within a few hours by a Doctor familiar with this type of injury or gangrene may result.
- Use a piece of cardboard or paper to search for leaks.

#### IMPORTANT:

- Keep hydraulic coupler tips and connectors clean. Dust, dirt, water, and foreign material are the major causes of hydraulic system damage.
- DO **NOT** attempt to service hydraulic system in the field. Precision fits require WHITE ROOM CARE during overhaul.



Figure 5.208: Hydraulic Pressure Hazard

## 5.11 Wheels and Tires

### 5.11.1 Drive Wheel

#### *Inflating Drive Wheel Tire*

#### **⚠ DANGER**

- Use a safety cage if available.
- Do NOT stand over tire. Use a clip-on chuck and extension hose.
- NEVER install a tube in a cracked wheel rim.
- NEVER weld a wheel rim.
- Do NOT exceed maximum inflation pressure as per label on tire.
- Make sure all the air is removed from a tire before removing the tire from the rim.



Figure 5.209: Drive Tire Inflation

#### **⚠ DANGER**

- NEVER use force on an inflated or partially inflated tire. Make sure the tire is correctly seated before inflating to operating pressure.
- Do NOT remove, install, or make repairs to a tire on a rim unless you have the proper equipment and experience to perform the job. Take the tire and rim to a qualified tire repair shop.
- If the tire is NOT in correct position on the rim or if over-inflated, the tire bead can loosen on one side, causing air to leak at high speed and with great force. An air leak of this nature can thrust the tire in any direction, endangering anyone in the area.

#### **⚠ DANGER**

To avoid bodily injury or death from unexpected startup of the machine, always stop the engine and remove the key from the ignition before leaving the operator's seat for any reason.

Visually check daily that tires have not lost pressure. Adjust pressure as required. Under-inflated drive tires can cause sidewall cracks. Check tire pressure every year.

Maintain tire pressure as follows:

1. Shut down the engine and remove key.
2. Determine the type and size of tire that is installed on your machine.
3. Refer to the following table to determine the appropriate tire pressure:

Table 5.4 Drive Wheel Tire Options (Ten Bolt)

18.4-26 Bar	600 65 R28 Bar	18.4-26 Turf	23.1-26 Turf
46 psi (317 kPa)	35 psi (241 kPa)	46 psi (317 kPa)	34 psi (234 kPa)

4. Adjust tire pressure as required.

#### **IMPORTANT:**

Check maximum inflation rating on tire sidewall. Do NOT exceed recommendation on tire.

## MAINTENANCE AND SERVICING

### *Tightening Drive Wheel Nuts*

At first use, or when a wheel is removed, torque drive wheel nuts after one hour of operation. Continue with torque procedure every hour until two consecutive checks produce no movement of the nuts.

#### **IMPORTANT:**

- To avoid damage to wheel rims and studs, tighten nuts by hand, do **NOT** use an impact gun, do **NOT** use lubricant or Never-Seez® compound, and do **NOT** overtighten wheel nuts.
  - Ensure only the manufacture's specified wheel nuts are used.
1. Tighten drive wheel nuts (A). Ensure nuts and studs are dry with no lubricant or Never-Seez® compound. Torque each to 375 ft lbf (510 N·m) using the tightening sequence shown at right.
  2. Repeat tightening sequence two additional times at specified torque.
  3. Repeat torque procedure every hour until two consecutive checks produce no movement of the nuts.

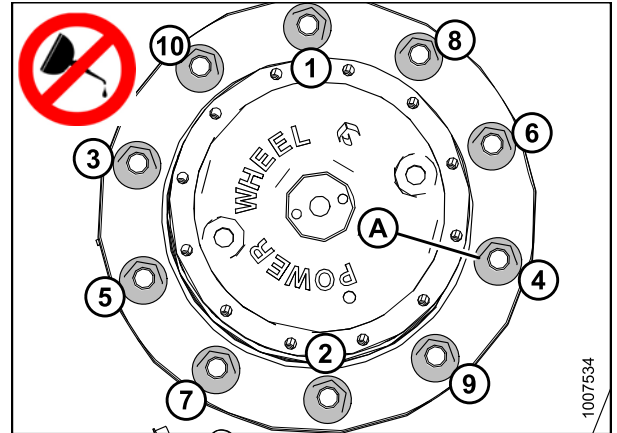

**Figure 5.210: Wheel Nut Tightening Sequence**

### *Servicing Drive Wheel*

#### **Raising Drive Wheel**

This procedure can be used on both drive wheels.

#### **CAUTION**

**Header MUST be removed and NO weight box installed. Use a hydraulic jack with minimum lifting capacity of 5000 lb (2268 kg) to provide adequate support for the machine.**

1. Remove the header.
2. Park windrower on level ground and block all wheels.

**⚠ DANGER**

To avoid bodily injury or death from unexpected startup of the machine, always stop the engine and remove the key from the ignition before leaving the operator's seat for any reason.

3. Place ground speed lever (A) in N-DETENT (B), shut down engine, and remove key.

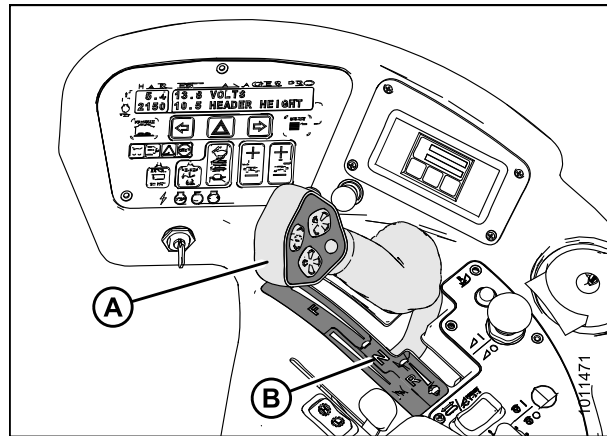

Figure 5.211: Ground Speed Lever

**⚠ CAUTION**

Jack stand must be capable of supporting a minimum of 5000 lb (2268 kg).

4. Place a jack under the leg jack point (A) and raise the drive wheel until it is slightly off ground. Place a jack stand beneath the lift cylinder mount (B).

**NOTE:**

Do **NOT** place jack stand under the cylinder. Use a small metal plate on top of the jack stand.

5. Lower the windrower onto the jack stand.

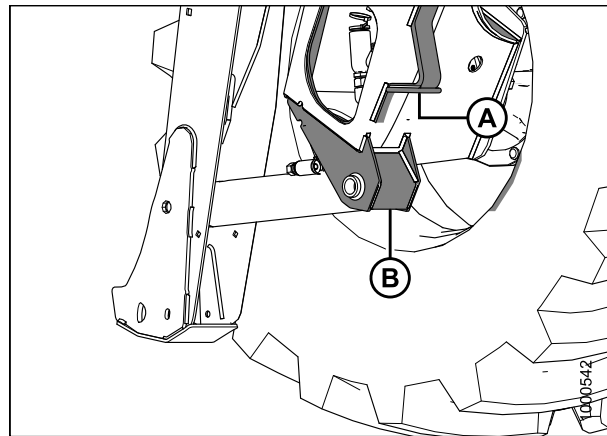

Figure 5.212: Drive Wheel Jack Point

Removing Drive Wheel

**⚠ CAUTION**

Use a suitable lifting device capable of supporting a minimum of 2000 lbs (907 kg) to lift the wheel assembly away from the windrower.

1. Raise the windrower drive wheel (A) off the ground. Refer to [Raising Drive Wheel, page 401](#).
2. Remove the wheel nuts (B).
3. Remove the drive wheel (A).

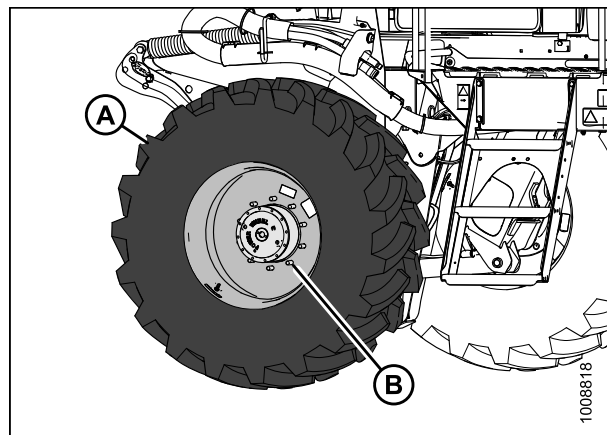

Figure 5.213: Drive Wheel

### Installing Drive Wheel

**NOTE:**

Windrower must be supported off the ground with stands. Refer to [Raising Drive Wheel, page 401](#).

1. Position drive wheel (A) against the wheel drive hub (B) so the air valve (C) is on the outside and the tire tread (D) points in cab-forward direction.

**NOTE:**

For turf tires (diamond tread), be sure arrow on sidewall points in cab-forward rotation.

2. Lift wheel onto hub using a lifting device.
3. Lower lifting device.
4. Line up the holes in the rim with the studs on the wheel drive hub and install wheel nuts (A).

**IMPORTANT:**

To avoid damage to wheel rims and studs, tighten nuts by hand. Do **NOT** use an impact gun, do **NOT** use lubricant or Never-Seez<sup>®</sup> compound, and do **NOT** overtighten wheel nuts.

5. Torque drive wheel nuts. Refer to [Tightening Drive Wheel Nuts, page 401](#).
6. Repeat tightening sequence two additional times ensuring the specified torque of 375 ft·lbf (510 N·m) is achieved each time.
7. Lower the windrower, and remove jack. Refer to [Lowering Drive Wheel, page 403](#).
8. Repeat torque procedure every hour until two consecutive checks confirm there is no movement of the nuts.

### Lowering Drive Wheel

This procedure is for lowering the drive wheel when it is raised on a jack stand. This procedure can be used on both drive wheels.

**⚠ CAUTION**

Jack stand must be capable of supporting a minimum of 5000 lb (2268 kg).

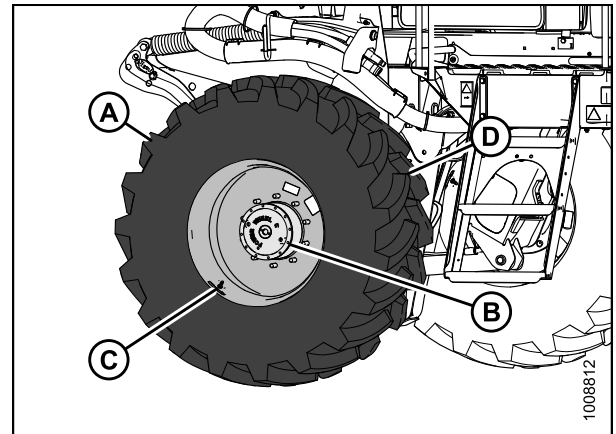

Figure 5.214: Drive Wheel

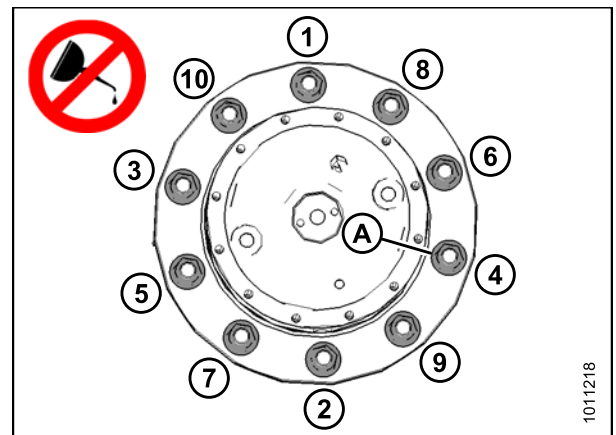

Figure 5.215: Drive Wheel Nuts

## MAINTENANCE AND SERVICING

1. Place a jack under the leg jack point (A), and raise the drive wheel slightly off the jack stand.
2. Remove the jack stand from under the cylinder lift mount (B), and lower the drive wheel to the ground.
3. Remove the jack.

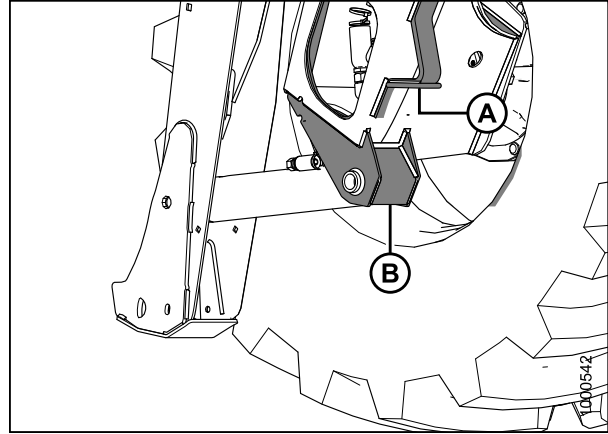

Figure 5.216: Drive Wheel Leg Jacking Point

### Lubrication

#### Checking Wheel Drive Lubricant Level

Check the wheel drive lubricant level every 200 hours or annually.

#### DANGER

To avoid bodily injury or death from unexpected startup of the machine, always stop the engine and remove the key from the ignition before leaving the operator's seat for any reason.

1. Park the windrower on level ground.
2. Stop the engine and remove the key.
3. Position windrower so plugs (A and B) are horizontally aligned with the center (C) of the hub.
4. Remove plug (A or B). The lubricant should be visible through the port or running out slightly. If lubricant needs to be added, refer to [Adding Wheel Drive Lubricant, page 404](#).

#### NOTE:

The type of lubricant used after the first lubricant change is different from the factory supplied lubricant.

5. Reinstall plugs and tighten.

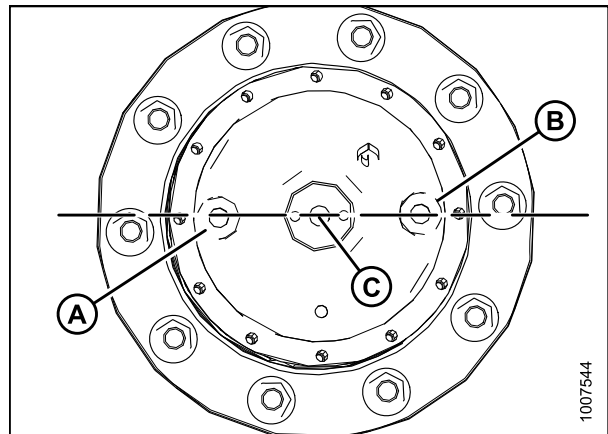

Figure 5.217: Wheel Drive

#### Adding Wheel Drive Lubricant

#### NOTE:

Do **NOT** mix lubricants of different brands or characteristics.

#### DANGER

To avoid bodily injury or death from unexpected startup of the machine, always stop the engine and remove the key from the ignition before leaving the operator's seat for any reason.



## MAINTENANCE AND SERVICING

1. Rotate the wheel drive so plugs (A) and (B) are horizontal (C).
2. Stop windrower and remove key from ignition.
3. Remove the two plugs (A) and (B). The oil should be visible through the hole, or slightly running out.
4. If lubricant needs to be added, remove the second plug (B), and add lubricant until lubricant runs out at (A). Refer to [8.1.3 Lubricants, Fluids, and System Capacities](#), page 444.

### NOTE:

The type of lubricant used after first lubricant change is different from factory supplied lubricant.

5. Reinstall and tighten plugs (A) and (B).
6. Start up and operate the windrower for a few minutes, then stop and check the oil level. Refer to [Checking Wheel Drive Lubricant Level](#), page 404. If necessary, add more oil.

### Changing Wheel Drive Lubricant

The wheel drive lubricant should be changed after the first 50 hours and then in accordance with the maintenance schedule. Change the lubricant when it is warm.

Check the level every 200 hours or annually, and change every 1000 hours.

### DANGER

**To avoid bodily injury or death from unexpected startup of the machine, always stop the engine and remove the key from the ignition before leaving the operator's seat for any reason.**

1. Park windrower on level ground and position windrower so drain plug (B) is at the lowest point.
2. Shut down the windrower and remove key from ignition.
3. Place a large enough container (about 2 quarts [2 liters]) under the lower drain plug (B).
4. Remove plugs (A and B), and drain lubricant into container.

### CAUTION

**Dispose of oil in a manner that complies with local rules and regulations.**

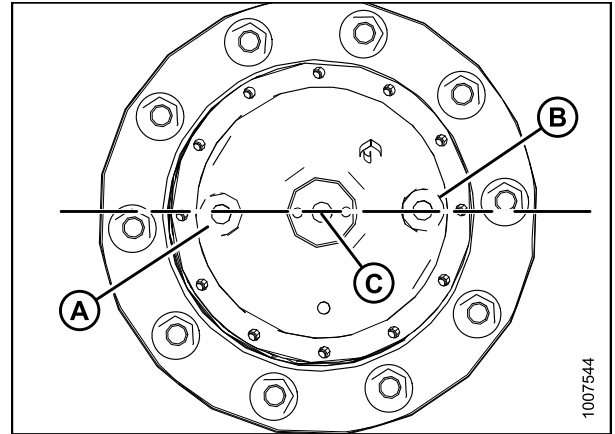

Figure 5.218: Wheel Drive

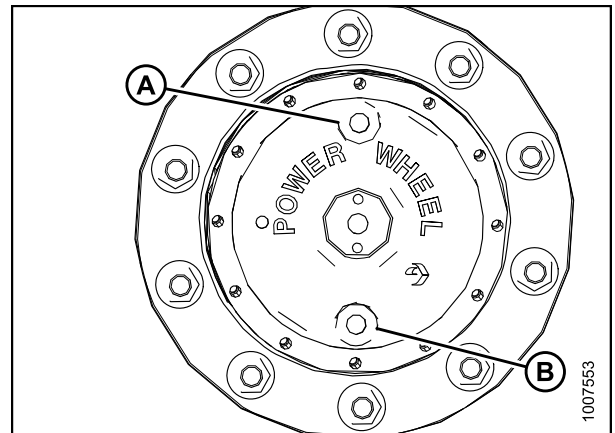

Figure 5.219: Wheel Drive

## MAINTENANCE AND SERVICING

5. After the lubricant has drained completely, position the windrower so that ports (A and B) on wheel are level with the center of the hub (C) as shown.
6. Add lubricant. Refer to [Adding Wheel Drive Lubricant, page 404](#).

**NOTE:**

The type of lubricant used after first lubricant change is different from factory supplied lubricant.

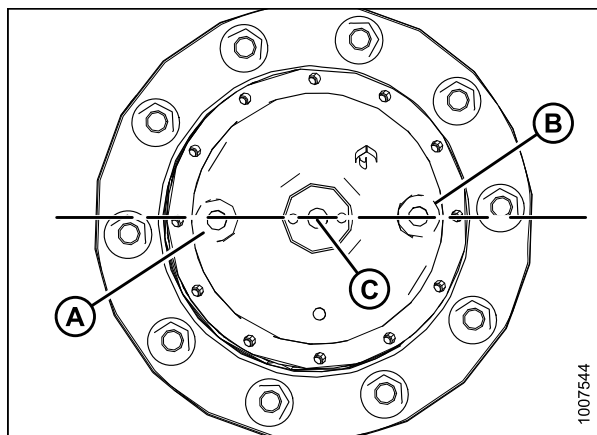

Figure 5.220: Wheel Drive

### 5.11.2 Caster Wheel

#### *Inflating Caster Tire*

**⚠ DANGER**

- Do NOT exceed maximum inflation pressure as per label on tire.
- Use a safety cage if available.
- Do NOT stand over tire. Use a clip-on chuck and extension hose.
- NEVER install a tube in a cracked wheel rim.
- NEVER weld a wheel rim.
- Make sure all the air is removed from a tire before removing the tire from the rim.

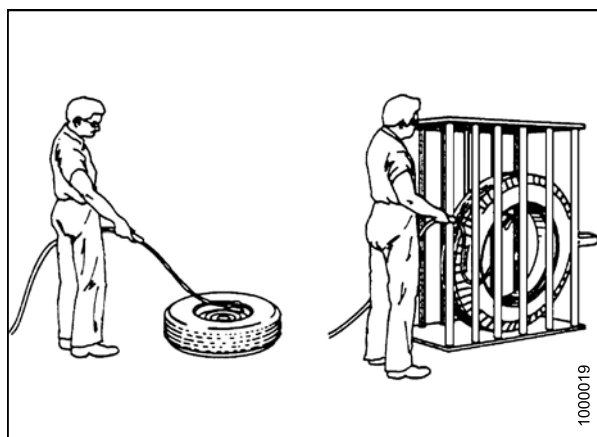

Figure 5.221: Safely Filling a Tire with Air

**⚠ DANGER**

- NEVER use force on an inflated or partially inflated tire. Make sure the tire is correctly seated before inflating to operating pressure.
- Do NOT remove, install, or make repairs to a tire on a rim, unless you have the proper equipment and experience to perform the job. Take the tire and rim to a qualified tire repair shop.
- If the tire is NOT in correct position on the rim or if too full of air, the tire bead can loosen on one side, causing air to leak at high speed and with great force. An air leak of this nature can thrust the tire in any direction, endangering anyone in the area.
- To avoid severe personal injury or death caused by machine runaway, shut off engine and remove key before performing any of the following checks and/or adjustments.

## MAINTENANCE AND SERVICING

Check tire pressure every year. Caster tire pressure should be 10 psi (69 kPa).

To maintain pressure, visually check daily that tires have not lost pressure, and adjust pressure as needed. Under-inflation of tires can cause sidewall cracks.

### NOTE:

If caster wheels shimmy, a possible cause is over-inflation.

**Table 5.5 Caster Tire Options**

Formed Caster	Forked Caster
7.5–16SL Single rib, 10-16 Front steer tire	16.5L–16.1 Rib implement flotation, 10–16 Front steer tire
10 psi (69 kPa)	10 psi (69 kPa)

### *Tightening Caster Wheel Nuts*

At first use or when a wheel is removed, check wheel nut/bolt torque every 15 minutes on the road or 1 hour in the field until the specified torque is maintained.

Once specified torque is maintained, check wheel nut/bolt torque after 10 and 50 hours (field or road operation) and then every 200 hour intervals thereafter.

To tighten the caster wheel nuts on either forked or formed caster wheels, follow these steps:

1. Position wheel assembly on hub and install wheel bolts (A).
2. Tighten wheel nuts (A) to 120 ft·lbf (163 N·m) using the tightening sequence suitable for the type of caster wheel shown at right. Repeat the tightening sequence three times.

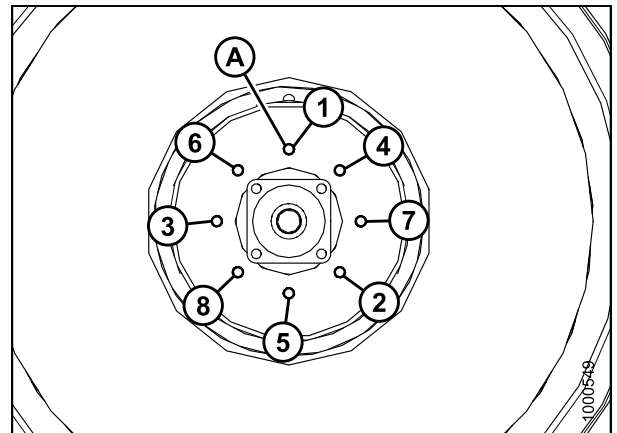

**Figure 5.222: Forked Caster Wheel Nut Tightening Sequence**

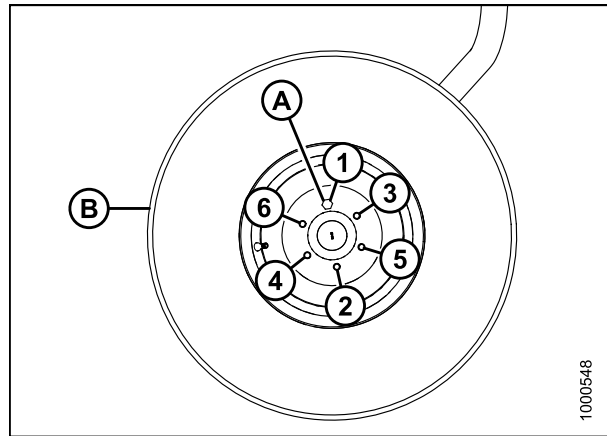

Figure 5.223: Formed Caster Wheel Nut Tightening Sequence

### *Servicing Caster Wheels*

#### Raising Caster Wheel (Formed and Forked)

This procedure is the same for forked and formed caster wheels.

#### **! DANGER**

To avoid bodily injury or death from unexpected startup of the machine, always stop the engine and remove the key from the ignition before leaving the operator's seat for any reason.

#### **! CAUTION**

Jack stand must be capable of supporting a minimum of 5000 lb (2268 kg).

1. Park windrower on level ground and block the drive wheels.
2. Place the ground speed lever (GSL [A]) in N-DETENT (B), stop the engine and remove the key.

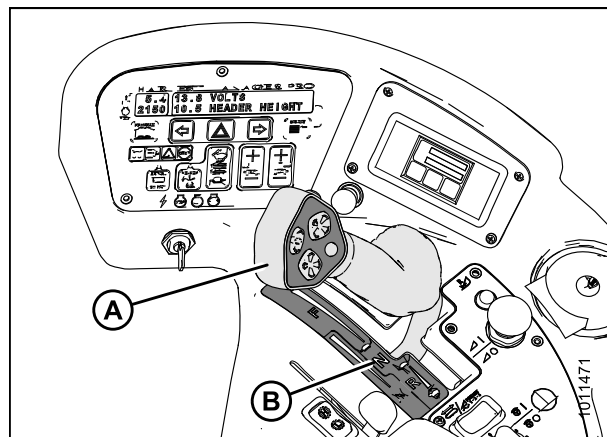
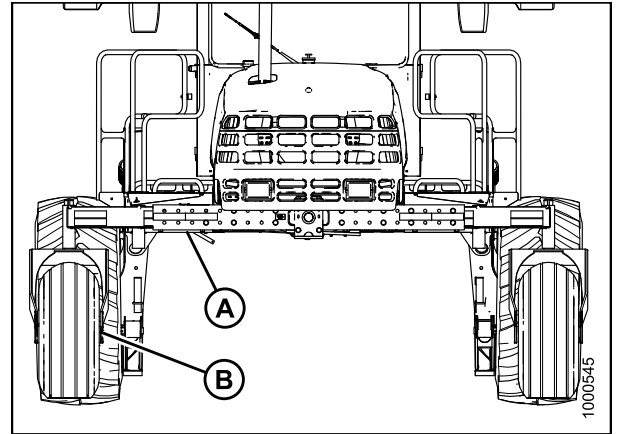

Figure 5.224: GSL Position

## MAINTENANCE AND SERVICING

3. Raise the end of walking beam (A) until the caster wheel assembly (B) is slightly off the ground. Use a suitable lifting device, capable of lifting 5000 lb (2268 kg) minimum.
4. Place a jack stand beneath the walking beam and lower the beam until resting on the stand.

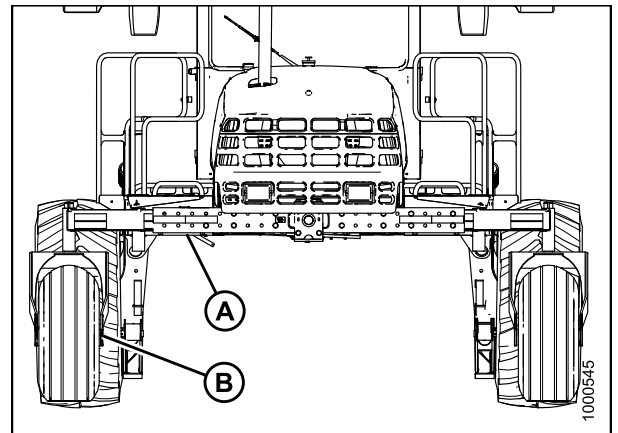

**Figure 5.225: Caster Wheels and Walking Beam (Engine-Forward View)**

### Lowering Caster Wheel (Formed and Forked)

This procedure is for lowering the caster wheel when it is raised on a jack stand. This procedure is the same for forked and formed caster wheels.

1. Raise the end of walking beam (A) slightly, using a suitable lifting device capable of lifting minimum 5000 lb (2268 kg).
2. Remove the jack stand and lower the end of the walking beam until the caster wheel assembly (B) is on the ground.
3. Remove blocks from the drive tires.



**Figure 5.226: Caster Wheel Assembly and Walking Beam (Engine-Forward View)**

Removing Forked Caster Wheel

**CAUTION**

Wheel assemblies are heavy. Support wheel assembly before removing axle bolts.

1. Raise caster wheel. Refer to *Raising Caster Wheel (Formed and Forked)*, page 408.
2. Remove the eight bolts (A) (four on each side of caster) attaching axle (B) and cover (C) to forked caster (E), and remove wheel assembly (D) from caster (E).

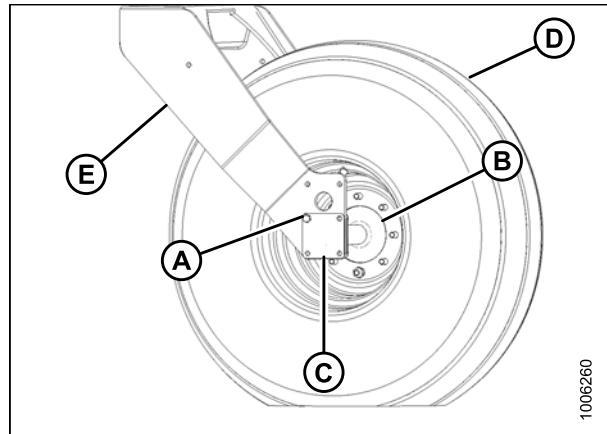

Figure 5.227: Forked Caster Wheel

3. Remove the eight wheel nuts (A) that secure the axle (B) to the wheel (C).
4. Separate axle (B) and wheel (C).

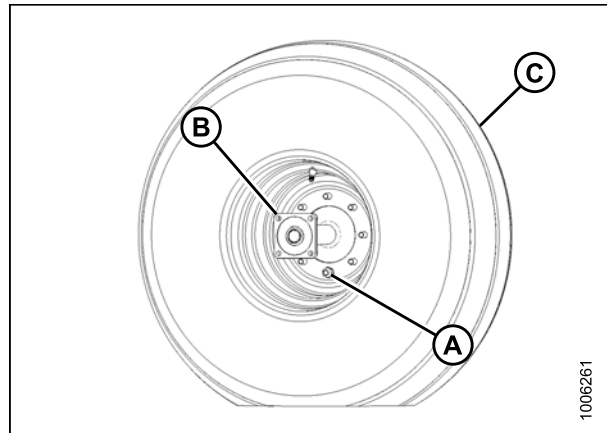

Figure 5.228: Forked Caster Wheel

Installing Forked Caster Wheel

1. Position wheel assembly (C) on axle assembly (B) and install wheel nuts (A).
2. Torque wheel nuts (A). Refer to *Tightening Caster Wheel Nuts*, page 407.

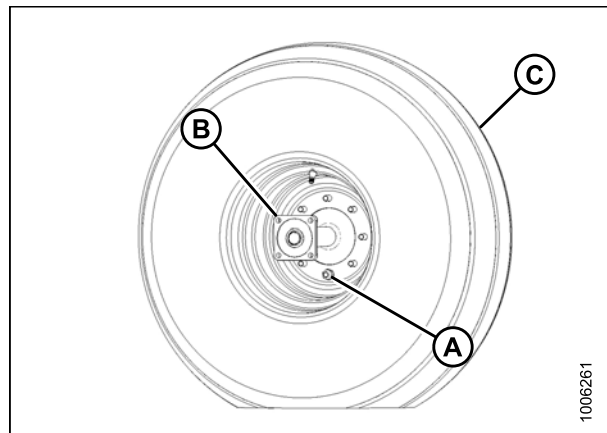

Figure 5.229: Forked Caster Wheel

## MAINTENANCE AND SERVICING

3. Position wheel assembly (D) in forked caster (E).
4. Position cover plates (C) and install eight bolts (A) (four on each side of caster) to secure axle (B) to caster (E). Torque bolts to 75–79 ft·lbf (97–107 N·m).
5. Lower caster wheel. Refer to [Lowering Caster Wheel \(Formed and Forked\)](#), page 409.

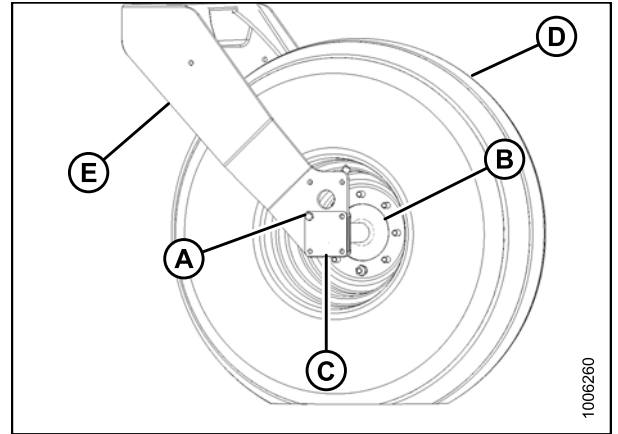

Figure 5.230: Forked Caster Wheel

### Removing Formed Caster Wheel

1. Raise caster wheel. Refer to [Raising Caster Wheel \(Formed and Forked\)](#), page 408.
2. Remove the six bolts (A) that secure the wheel (B) to the hub.
3. Remove wheel (B).

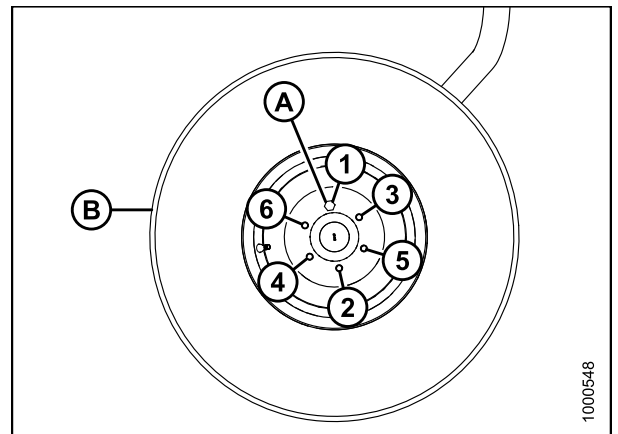

Figure 5.231: Formed Caster Wheel

### Installing Formed Caster Wheel

1. Position wheel assembly (B) on hub, and install the six wheel bolts (A).
2. Torque bolts (A). Refer to [Tightening Caster Wheel Nuts](#), page 407.
3. Lower caster wheel. Refer to [Lowering Caster Wheel \(Formed and Forked\)](#), page 409.

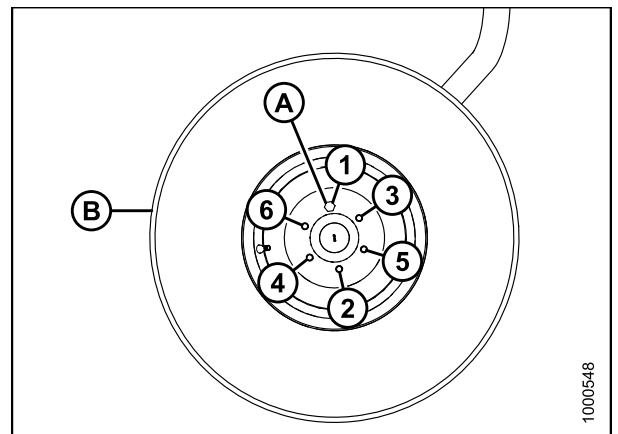

Figure 5.232: Formed Caster Wheel

## MAINTENANCE AND SERVICING

### *Tightening Caster Wheel Anti-Shimmy Dampeners*

Each caster is equipped with a fluid-filled anti-shimmy dampener (A).

The mounting bolts (B) need to be checked periodically for security. Refer to [5.12 Maintenance Schedule, page 414](#).

- Inboard bolt should be tightened to 100 ft·lbf (135 N·m)
- Outboard bolt should be tightened to 85 ft·lbf (115 N·m)

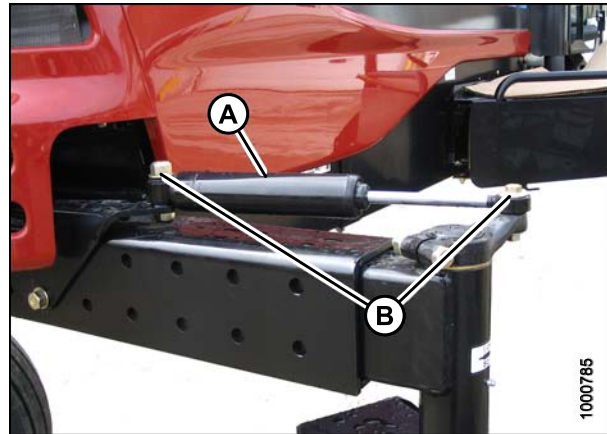

**Figure 5.233: Anti-Shimmy Dampener**



## MAINTENANCE AND SERVICING

### *Ballast Requirements*

Fluid ballasting of rear caster tires is recommended to provide adequate machine stability when using large headers on the windrower. Also, the stability of the machine varies with different attachments, windrower options, terrain, and the operator's driving technique.

Ballast capability per tire is at a maximum fill of 75%, or when fluid is level with valve stem when the stem is positioned at 12 o'clock. Fluid can be added to any level up to maximum fill. Always add an equal amount of fluid on both sides.

**Table 5.6 Recommended Ballast Weight**

Header Description		Recommended Ballast				Recommended Tire Size
		Level Ground		Hills		
Type	Size	Per Tire	Both Tires	Per Tire	Both Tires	
		US Gal (liters)	lb (kg) <sup>29</sup>	US Gal (liters)	lb (kg) <sup>29</sup>	
<b>A-Series</b>	All	0				7.5 X 16 10 X 16 16.5 X 16.1
<b>R-Series</b>	13-foot ONLY					
<b>D-Series</b>	25-foot and smaller	0				
	30-foot single or double reel without conditioner 35-foot single reel					
	30-foot double reel steel fingers and conditioner 35-foot double reel (5 or 6-bat)	18 (69)	380 (170)	30 (115)	630 (288)	Level ground: 10 X 16 Level ground: 16.5 X 16.1 Hills: 16.5 X 16.1
	40-foot	30 (115)	630 (288)	41 (158)	830 (377)	16.5 X 16.1

29. Weights are given for typical calcium chloride and water mixtures. Weight is reduced by 20% if only water is used (for areas that do **not** require anti-freeze protection).

## 5.12 Maintenance Schedule

The Maintenance Schedule specifies the recommended periodic maintenance procedures and service intervals. Regular maintenance is the best insurance against early wear and untimely breakdowns. Follow this schedule to maximize machine life.

For detailed instructions, refer to the various procedures in this chapter. Use the fluids and lubricants specified in [8.1 Recommended Fuel, Fluids, and Lubricants, page 443](#).

**Service Intervals:** The recommended service intervals are in hours of operation. Where a service interval is given in more than one time frame, for example 100 hours or annually, service the machine at whichever interval is reached first.

**IMPORTANT:**

Recommended intervals are for average conditions. Service the machine more often if operated under adverse conditions (severe dust, extra heavy loads, etc.).



 **CAUTION**

Carefully follow safety messages given in [1 Safety, page 1](#).

### 5.12.1 Maintenance Schedule/Record

WINDROWER SERIAL NUMBER: \_\_\_\_\_

Combine this record with the record in the header operator's manual. Make copies of this page to continue the record.

Action: ✓ Check ♦ Lubricate ▲ Change ✱ Clean													
	Hour meter reading												
	Service date												
	Serviced by												
Preseason or Annual. Refer to <a href="#">4.3.3 Preseason Checks/Annual Service, page 161</a> .													
<b>First hour<sup>30</sup></b>													
✓	Drive wheel nuts												
Refer to <a href="#">Tightening Drive Wheel Nuts, page 401</a> .													
<b>First 5 hours<sup>30</sup></b>													
✓	A/C compressor belt												
Refer to <a href="#">Tensioning Air Conditioner (A/C) Compressor Belt, page 347</a> .													
✓	Caster wheel nuts												
Refer to <a href="#">Tightening Caster Wheel Nuts, page 407</a> .													
✓	Caster wheel anti-shimmy dampener												
bolts. Refer to <a href="#">Tightening Caster Wheel Anti-Shimmy Dampeners, page 412</a> .													

30. Begins from first use of machine.

## MAINTENANCE AND SERVICING

Action: ✓ Check    ⬇ Lubricate    ▲ Change    ✱ Clean													
✓	Walking beam width adjustment bolts												
Refer to <a href="#">4.3.8 Adjusting Caster Tread Width, page 177.</a>													
<b>First 10 hours<sup>31</sup></b>													
✓	Walking beam width adjustment bolts												
Refer to <a href="#">4.3.8 Adjusting Caster Tread Width, page 177.</a>													
✓	Neutral adjustment <sup>32</sup>												
<b>Every 10 hours or daily<sup>31</sup></b>													
✱	A/C condenser <sup>33</sup>												
Refer to <a href="#">5.8.3 Cleaning Cooler Box Components, page 350.</a>													
✱	Charge air cooler <sup>33</sup>												
Refer to <a href="#">5.8.3 Cleaning Cooler Box Components, page 350.</a>													
✓	Engine oil level <sup>33</sup>												
Refer to <a href="#">5.7.3 Checking Engine Oil Level, page 311.</a>													
✓	Engine coolant level <sup>33</sup>												
Refer to <a href="#">Checking Coolant Level, page 337.</a>													
✓	Fuel tank <sup>33</sup>												
Refer to <a href="#">Filling the Fuel Tank, page 327.</a>													
✓	Fuel filter water trap <sup>33</sup>												
Refer to <a href="#">Removing Water from Fuel System, page 328.</a>													
✓	Hydraulic hoses and lines <sup>33</sup>												
Refer to <a href="#">5.10.7 Hoses and Lines, page 399.</a>													
✱	Hydraulic oil cooler <sup>33</sup>												
Refer to <a href="#">5.10.2 Hydraulic Oil Cooler, page 390.</a>													
✓	Hydraulic oil level <sup>33</sup>												
Refer to <a href="#">5.10.1 Checking and Filling Hydraulic Oil, page 389.</a>													
✱	Radiator <sup>33</sup>												
Refer to <a href="#">5.8 Maintaining Engine Cooling Box, page 349.</a>													
✓	Tire inflation <sup>33</sup>												
Refer to <a href="#">Inflating Drive Wheel Tire, page 400.</a>													
✓	Diesel exhaust fluid (DEF) level <sup>33</sup>												
Refer to <a href="#">3.16.1 Fuel and Diesel Exhaust Fluid (DEF) Display Module, page 66.</a>													

31. Begins from first use of machine.

32. Dealer adjusted.

33. A record of daily maintenance is not normally required but is at the Owner/Operator's discretion.

## MAINTENANCE AND SERVICING

Action: ✓ Check    ⬇ Lubricate    ▲ Change    ✱ Clean	
<b>First 50 hours<sup>34</sup></b>	
✓	Hose clamps: air intake/radiator/ heater/hydraulic <sup>35</sup> . Refer to specific hose clamp section.
✓	Walking beam width adjustment bolts Refer to <a href="#">4.3.8 Adjusting Caster Tread Width, page 177</a> .
✓	Caster wheel anti-shimmy dampener bolts (if installed). Refer to <a href="#">Tightening Caster Wheel Anti-Shimmy Dampeners, page 412</a> .
▲	Main gearbox oil Refer to <a href="#">Changing Lubricant, page 343</a> .
▲	Drive wheel lubricant Refer to <a href="#">Changing Wheel Drive Lubricant, page 405</a> .
▲	Charge system oil filter Refer to <a href="#">Charge Oil Filter, page 392</a> .
▲	Return oil filter Refer to <a href="#">Return Oil Filter, page 393</a> .
<b>Every 50 hours<sup>34</sup></b>	
✱	Cab fresh air intake filter Refer to <a href="#">Inspecting and Cleaning Fresh Air Filter Element, page 301</a> .
⬇	Caster pivots Refer to <a href="#">5.4.2 Lubrication Points, page 293</a> .
⬇	Forked caster spindle bearings Refer to <a href="#">5.4.2 Lubrication Points, page 293</a> .
✓	Gearbox oil level Refer to <a href="#">Checking Lubricant Level and Adding Lubricant, page 342</a> .
⬇	Top lift link pivots Refer to <a href="#">5.4.2 Lubrication Points, page 293</a> .
⬇	Walking beam center pivot <sup>36</sup>

34. Begins from first use of machine.

35. Hand-tighten unless otherwise noted.

36. 2014 and previous.

## MAINTENANCE AND SERVICING

Action: ✓ Check ♦ Lubricate ▲ Change * Clean	
<b>Once a year</b> <sup>37 38</sup>	
✓	A/C blower Refer to <a href="#">Air Conditioning Compressor Coolant Cycling, page 162.</a>
✓	Antifreeze concentration Refer to <a href="#">Checking Engine Coolant Strength, page 338.</a>
✓	Battery charge Refer to <a href="#">Maintaining the Battery, page 354.</a>
✓	Battery fluid level Refer to <a href="#">Charging the Battery, page 356.</a>
▲	Fuel tank vent line filter Refer to <a href="#">Replacing Fuel Tank Vent Filter, page 321.</a>
▲	Diesel Exhaust Fluid (DEF) vent hose filter. Refer to <a href="#">Replacing the Diesel Exhaust Fluid (DEF) Vent Hose Filter, page 331.</a>
✓	Steering linkages Refer to <a href="#">Checking Steering Link Pivots, page 297.</a>
<b>Every 100 hours or once a year</b> <sup>39 38</sup>	
*	Cab air return filter Refer to <a href="#">Cleaning Return Air Cleaner/Filter, page 304.</a>
✓	Cab suspension limit straps Refer to <a href="#">5.5.5 Cab Suspension Limit Straps, page 300</a>
<b>Every 250 hours or once a year</b> <sup>39 38</sup>	
▲	Engine oil and filter Refer to <a href="#">5.7.4 Changing Engine Oil, page 312.</a>
▲	Engine air cleaner primary filter element. Refer to <a href="#">Removing Primary Air Filter, page 315</a> and <a href="#">Installing Primary Air Filter, page 317.</a>
♦	Formed caster wheel hub bearings Refer to <a href="#">5.4.2 Lubrication Points, page 293.</a>
✓	Drive wheel lubricant Refer to <a href="#">Checking Wheel Drive Lubricant Level, page 404.</a>
✓	Exhaust system Refer to <a href="#">5.7.11 Inspecting Exhaust System, page 344.</a>

37. Begins from first use of machine.

38. It is recommended that annual maintenance be done prior to start of operating season.

39. Begins from first use of machine, whichever occurs first.

## MAINTENANCE AND SERVICING

Action: ✓ Check    ⬇ Lubricate    ▲ Change    ✱ Clean															
<b>Every 500 hours or once a year</b> <sup>40 41</sup>															
▲	Fuel Filters														
Refer to <a href="#">Maintaining Fuel Filters, page 322.</a>															
▲	Gearbox Lubricant														
Refer to <a href="#">Changing Lubricant, page 343.</a>															
▲	Charge System and Return Oil Filters														
Refer to <a href="#">5.10.4 Changing Hydraulic Oil Filters, page 391.</a>															
✓	Safety Systems														
Refer to <a href="#">5.5.2 Safety Systems, page 294.</a>															
<b>Every 1000 hours</b> <sup>40</sup>															
▲	Drive wheel lubricant														
Refer to <a href="#">Changing Wheel Drive Lubricant, page 405.</a>															
✱	Supply module filter														
Refer to <a href="#">Cleaning and Inspecting the Supply Module Filter, page 335.</a>															
<b>1500 hours or every two years</b> <sup>40</sup>															
▲	Hydraulic Oil														
Refer to <a href="#">5.10.3 Draining Hydraulic Oil, page 390.</a>															
<b>2000 hours</b> <sup>40</sup>															
▲	Engine Crank Case Filter														
Refer to <a href="#">Replacing Engine Oil Filter, page 313.</a>															
<b>4500 hours or every 3 years</b> <sup>40</sup>															
▲	DEF Supply Module Filter														
Refer to <a href="#">Supply Module Filter, page 334.</a>															
<b>5000 hours or every two years</b> <sup>40</sup>															
✓	Engine Valve Tappet Clearance														

40. Begins from first use of machine.

41. It is recommended that annual maintenance be done prior to start of operating season.

## **6 Options and Attachments**

### **6.1 Cab**

#### **6.1.1 AM/FM Radio**

The cab is pre-wired for easy installation of a DIN “E”-style audio component available from your MacDon Dealer. Speakers are factory-installed.

In order to retain radio settings and preset memory with the battery disconnect turned off, select a radio with non-volatile settings memory.

For installation details, refer to the unloading and assembly instructions supplied with your windrower.

#### **6.1.2 HID Auxiliary Lighting**

Provides additional field lighting. The kit includes two cab-mounted high intensity discharge (HID) lamps and installation instructions.

MD #B5596

Instruction MD #169621 is included in the bundle.

#### **6.1.3 Windshield Shades**

Retractable sun shades for front and rear windows. Attachment hardware is included.

MD #B4866

Instruction MD #169218 is included in the bundle.

#### **6.1.4 Automated Steering Systems**

A MacDon-approved automated steering system is available from MacDon Dealers that provide installation and support services.

MacDon windrowers are prewired for either the Trimble® AutoPilot™ hydraulically integrated steering system or the Trimble® EZ-Pilot® wheel/column based assisted steering system. The windrower’s ground speed lever (GSL) has an automated steering (autosteer) engage switch and the Trimble® display mounting kit MD #183348 is supplied in the cab.

The Trimble® AutoPilot™ system requires the MacDon automated steering hydraulic interface kit MD #B5589. Installation instruction MD #169539 is included in the bundle.

Other GPS providers may supply parts in their vehicle specific installation packages or make installation kits available through MacDon Dealers.

## 6.2 Header Operation

### 6.2.1 Booster Spring Kit (External)

Available for headers over 6000 lb (2724 kg) to increase the float capacity.

MD #B4659 - Booster Spring Kit (external) includes two springs (one for each side) and mounting bracket.

Instruction MD #169032 is included in the bundle.

### 6.2.2 Booster Spring Kit (Internal)

An additional spring that is installed inside the header lift spring for increased float capacity.

MD #B5303 - includes one spring and castings for one side of the windrower.

Instruction MD #169316 is included in the bundle.

### 6.2.3 Light Header Flotation

Available for headers that do not require as much spring tension for header float.

MD #B4664

Instruction MD #169033 is included in the bundle.

### 6.2.4 Double Windrow Attachment (DWA)

Allows auger and rotary headers to lay a double windrow when installed on a self-propelled windrower. The kit includes a draper deck, linkage assembly, hydraulics, and installation instructions.

MD #C1987 consists of:

- MD #B4655 Deck
- MD #B5270 Linkage assembly
- MD #B5301 Hydraulic kit
- Double Windrow Attachment (DWA) manual

### 6.2.5 Draper Header Reel Drive and Lift Plumbing

Base kit required to run draper header. Includes draper header reel drive and lift plumbing (less valve) and reel fore-aft hydraulics.

**NOTE:**

If the last digit of windrower code is B, this bundle is already installed.

MD #B5577

Instruction MD #169537 is included in the bundle.



### **6.2.6 Draper Header Case Drain Kit**

The Draper Header Case Drain kit must be installed when attaching a MacDon D50, D60, or D65 draper header with an upper cross auger (UCA), but without double draper drive. Case Drain Kit (MD #B5842) is **NOT** required for double-draper drive headers equipped with kits (MD #B5606) and (MD #B5653).

MD #B5842

### **6.2.7 Header Drive Reverser**

Allows the conditioner, knife, auger, and reel to reverse on the auger header, and the conditioner and knife to reverse on the draper header.

MD #B4656

Instruction MD #169213 is included with the bundle.

### **6.2.8 Self-Aligning Center-Link**

Allows the center-link cylinder to be hydraulically positioned and connected to the header without leaving the operator's station.

Hydraulic center-link (MD #B4650) must be installed.

MD #B4802

Instruction MD #169004 included in the bundle.

### **6.2.9 Rotary Header Drive Hydraulics (13-foot)**

Used to allow operation of a 13-foot rotary header. The kit includes header drive plumbing and installation instructions.

MD #B5510

Instructions are included in the bundle.

- MD #169544 13-foot R80 and R85 attached to M150 or M155

### **6.2.10 Pressure Sensor Kit**

For enhanced monitoring of the knife drive (or reel drive) hydraulic pressure, and warns of overload conditions.

MD #B5574

Instruction MD #169031 is included in the bundle.

### **6.2.11 Swath Roller**

An axle-mounted swath roller increases the windrow's resistance to wind disturbance, especially in canola or similar crops. It can be fitted with a hydraulic lift with in-cab controls.

Contact your MacDon Dealer for information.

### **6.2.12 Valve for Driving Rotary Disc Header**

This valve is required to run a rotary disc header.

MD #B4657

## 6.3 Transport

### 6.3.1 Weight Box

To move the windrower without an attached header, attach the weight box to the header lift system. The weight box allows you to transport a header behind the windrower by providing additional weight on the drive wheels.

MD #B5238 – Weight box without harness<sup>42</sup>

MD #B5240 – Weight box without harness and concrete<sup>42</sup>

Instruction MD #169280 is included in the bundle.

MD #B5280 – Wiring harness for weight box. Includes hitch pin and wiring for use with slow speed transport. Use with MD #B5238 and MD #B5240. Required when towing header with SP windrower.

Instruction MD #169278 is included in the bundle.

### 6.3.2 Lighting and Marking for Cab-Forward Road Travel

Allows the windrower to be compliant with vehicle lighting regulations when travelling in the cab-forward mode on public roads. The kit includes red tail lights, slow moving vehicle (SMV) markings, hardware, and installation instructions.

MD #B5412

Instruction MD #169426 is included in the bundle.

### 6.3.3 Towing Harness

The towing harness is used together with the weight box when towing a D-Series draper header equipped with slow speed transport option behind the windrower.

MD #B5280 - Weight box harness only. Includes hitch pin and wiring for use with slow speed header transport option.

Instruction MD #169278 is included in the bundle.

### 6.3.4 Transport Drawbar

The transport drawbar mounts to the walking beam and allows the windrower to tow MacDon headers equipped with a slow-speed transport system. This drawbar is to be used for hitching tow-behind swath rollers only. Requires a weight box.

MD #B5411<sup>43</sup>

Instruction MD #169420 is included in the bundle.

---

42. Wiring harness MD #B5280 is also required to tow a header. Refer to [6.3.3 Towing Harness, page 423](#).

43. Weight box is required. Refer to [6.3.1 Weight Box, page 423](#).

## **6.4 Engine**

### **6.4.1 Engine Block Heater**

Contact your nearest Cummins Engine Distributor, and provide your engine model and serial numbers to ensure the proper heater is supplied.

### **6.4.2 Engine Fan Air Baffle**

Prevents the windrow from being disturbed by engine cooling fan air blast.

MD #B5440

Instruction MD #169443 is included in the bundle.

# 7 Troubleshooting

## 7.1 Engine Troubleshooting

Symptom	Problem	Solution	Section
Engine hard to start or will not start	Controls not in NEUTRAL	Move GSL to NEUTRAL.	<a href="#">Starting the Engine, page 163</a>
		Move steering wheel to locked position.	
		Disengage header drive switch.	<a href="#">4.4.4 Header Drive, page 203</a>
	NEUTRAL Interlock misadjusted	Contact Dealer.	Contact Dealer
	No fuel to engine	Fill empty fuel tank. Replace clogged filter.	<a href="#">Filling the Fuel Tank, page 327</a> and <a href="#">Maintaining Fuel Filters, page 322</a>
	Old fuel in tank	Drain tank. Refill with fresh fuel.	<a href="#">5.7.7 Fuel System, page 321</a>
	Water, dirt, or air in fuel system	Drain, flush, fill, and prime system.	
	Improper type of fuel	Use proper fuel for operating conditions.	<a href="#">8.1.2 Fuel Specifications, page 443</a>
	Crankcase oil too heavy	Use recommended oil.	<a href="#">8.1.3 Lubricants, Fluids, and System Capacities, page 444</a>
	Low battery output	Have battery tested. Check battery electrolyte level.	<a href="#">5.9.2 Battery, page 354</a>
	Poor battery connection	Clean and tighten loose connections.	
	Faulty starter	Contact Dealer.	Contact Dealer
	Loose electrical connection at fuel pump	Ensure connector at pump is fully pushed in.	Contact Dealer
	Wiring shorted, circuit breaker open	Check continuity of wiring and breaker (manual reset).	<a href="#">Checking and Replacing Fuses, page 381</a>
	ECM fuse (1 of 2) blown	Replace.	
	ECM Ignition relay faulty		
	NEUTRAL Logic relay faulty		
Faulty injectors	Contact Dealer.	Contact Dealer	

## TROUBLESHOOTING

Symptom	Problem	Solution	Section
Engine knocks	Engine out of time	Contact Dealer.	Contact Dealer
	Insufficient oil	Add oil.	<a href="#">Adding Engine Oil, page 313</a>
	Low or high coolant temperature	Contact Dealer.	Contact Dealer
	Improper fuel	Use proper fuel.	<a href="#">8.1.2 Fuel Specifications, page 443</a>
Low oil pressure	Low oil level	Add oil.	<a href="#">Adding Engine Oil, page 313</a>
	Improper type of oil	Drain and fill crankcase with proper oil.	<a href="#">8.1.3 Lubricants, Fluids, and System Capacities, page 444</a>
	Worn components	Contact Dealer.	Contact Dealer
Internal parts worn			
High oil consumption	Crankcase oil too light	Use recommended oil.	<a href="#">8.1.3 Lubricants, Fluids, and System Capacities, page 444</a>
	Oil leaks	Check for leaks around gaskets, seals, and drain plugs.	<a href="#">5.7.3 Checking Engine Oil Level, page 311</a>
	Unsteady fuel supply	Change filter on fuel tank vent line. Replace clogged fuel filter.	<a href="#">Replacing Fuel Tank Vent Filter, page 321</a> and <a href="#">5.7.7 Fuel System, page 321</a>
Engine runs irregularly or stalls frequently	Water or dirt in fuel system	Drain, flush, and fill fuel system.	<a href="#">8.1.3 Lubricants, Fluids, and System Capacities, page 444</a>
	Low coolant temperature	Remove and check thermostat.	Contact Dealer
	Air in fuel system	Contact Dealer.	
	Dirty or faulty injectors		

## TROUBLESHOOTING

Symptom	Problem	Solution	Section
Lack of power	Incorrect timing	Contact Dealer.	Contact Dealer
	Engine oil viscosity too high	Use recommended oil.	<a href="#">8.1.3 Lubricants, Fluids, and System Capacities, page 444</a>
	Intake air restriction	Service air cleaner.	<a href="#">5.7.5 Air Intake System, page 314</a>
	Clogged fuel filter	Replace primary fuel filter, and if necessary, replace secondary fuel filter.	<a href="#">Maintaining Fuel Filters, page 322</a>
	High back pressure	Clean out or replace exhaust canisters.	<a href="#">5.7.11 Inspecting Exhaust System, page 344</a>
	Improper type of fuel	Use proper fuel.	<a href="#">8.1.2 Fuel Specifications, page 443</a>
	High or low engine temperature	Remove and check thermostat.	Contact Dealer
	Improper valve clearance	Contact Dealer.	
Faulty injectors			
Engine temperature below normal	Defective thermostat	Remove and check thermostat.	
Warning alarm sounds	Engine overheated	Check coolant level.	<a href="#">Checking Coolant Level, page 337</a>
		Check thermostat.	Contact Dealer
	Low engine oil pressure	Check oil level.	<a href="#">5.7.3 Checking Engine Oil Level, page 311</a>
	Low transmission oil pressure		<a href="#">5.10.1 Checking and Filling Hydraulic Oil, page 389</a>

## TROUBLESHOOTING

Symptom	Problem	Solution	Section
Engine overheats	Low coolant level	Fill reserve tank to proper level. Check system for leaks.	<a href="#">5.7.9 Engine Cooling System, page 337</a>
	Water only for coolant	Replace with antifreeze.	
	Engine overloaded	Reduce ground speed.	<a href="#">Driving Forward in Cab-Forward Mode, page 171</a>
	Defective pressurized coolant tank cap	Replace cap.	<a href="#">Inspecting Pressurized Coolant Tank Cap, page 338</a>
	Defective fan belt	Replace belt	<a href="#">Replacing Fan Belt, page 345</a>
	Dirty radiator screen, rotors turning	Check for obstructions in ducting from screen to fan shroud.	<a href="#">5.8 Maintaining Engine Cooling Box, page 349</a>
	Dirty radiator screen, rotors not turning	Check connections to rotor electric motor.	
	Dirty radiator core	Clean radiator.	<a href="#">5.7.9 Engine Cooling System, page 337</a>
	Cooling system dirty	Flush cooling system.	
	Defective thermostat	Remove and check thermostat.	Contact Dealer
	Defective temperature gauge or sender	Check coolant temperature with thermometer. Replace gauge if necessary.	
Defective water pump	Contact Dealer.		
High fuel consumption	Clogged or dirty air cleaner	Service air cleaner.	<a href="#">5.7.5 Air Intake System, page 314</a>
	Engine overloaded	Reduce ground speed.	<a href="#">Driving Forward in Cab-Forward Mode, page 171</a>
	Improper valve clearance	Contact Dealer.	Contact Dealer
	Engine out of time		
	Dirty injector nozzles		
	Low engine temperature	Check thermostat.	
Improper type of fuel	Use proper fuel.	<a href="#">8.1.2 Fuel Specifications, page 443</a>	



## TROUBLESHOOTING

Symptom	Problem	Solution	Section
Starter cranks slowly or will not operate	Low battery output	Check battery charge.	<a href="#">Maintaining the Battery, page 354</a>
	Loose or corroded battery connections	Clean and tighten loose connections.	
	Controls not in NEUTRAL	Move GSL to NEUTRAL.	<a href="#">Driving Forward in Cab-Forward Mode, page 171</a>
		Move steering wheel to CENTER position.	<a href="#">Driving Reverse in Cab-Forward Mode, page 172</a>
		Disengage header.	<a href="#">Engaging and Disengaging the Header, page 203</a>
	Relay not functioning	Check relay and wire connections.	<a href="#">5.9 Electrical System, page 354</a>
	Main fuse defective/blown	Replace main fuse.	
	Key power fuse blown	Replace.	
	Key switch worn or terminals loose	Contact Dealer.	Contact Dealer
	Switch at Interlock not closed or defective	Adjust switch or replace. Contact your Dealer.	
Crankcase oil too high viscosity	Use recommended oil.	<a href="#">8.1.3 Lubricants, Fluids, and System Capacities, page 444</a>	
Air filters require frequent cleaning	Aspirator plugged	Clean out aspirator.	<a href="#">5.7.5 Air Intake System, page 314</a>

## TROUBLESHOOTING

### 7.2 Electrical Troubleshooting

Symptom	Problem	Solution	Section
Low voltage and/or battery will not charge	Defective battery	Have battery tested.	<a href="#">5.9.2 Battery, page 354</a>
	Loose or corroded connections	Clean and tighten battery connections.	<a href="#">Maintaining the Battery, page 354</a>
	Defective alternator belt	Replace worn belt.	<a href="#">Replacing Fan Belt, page 345</a>
	Alternator or voltage regulator not connected properly	Connect properly.	<a href="#">5.9.2 Battery, page 354</a>
	Dirty or defective alternator, defective voltage regulator, or high resistance in circuit	Contact Dealer.	Contact Dealer
Lights dim	Defective light switch		
	High resistance in circuit or poor ground on lights	Check the wiring circuit for a break in a wire or a poor ground.	—
Lights do not light	Burned out or defective light bulb	Replace light bulb.	<a href="#">Replacing Headlight Bulb, page 364</a>
			<a href="#">Replacing Bulb in Cab-Forward Flood Light, page 367</a>
			<a href="#">Replacing Bulb in Rear Flood Light, page 373</a>
	Broken wiring	Check wiring for broken wire or shorts.	—
	Poor ground on lights	Clean and tighten ground wires.	—
	Open or defective circuit breaker	Check circuit breaker.	<a href="#">5.9.14 Accessing Circuit Breakers and Fuses, page 381</a>
Defective relay	Replace relay.	<a href="#">Replacing Circuit Breakers and Relays, page 382</a>	
	Defective light switch	Contact Dealer.	Contact Dealer
Turn signals or indicators showing wrong direction	Reversed wires	Contact Dealer.	Contact Dealer
No current to cab	Broken or disconnected wire	Contact Dealer.	Contact Dealer
	Circuit breaker tripped	Breaker automatically resets.	—
	Battery disconnect switch is OFF	Turn battery disconnect switch ON.	<a href="#">Battery Main Disconnect Switch, page 355</a>

## TROUBLESHOOTING

### 7.3 Hydraulics Troubleshooting

Symptom	Problem	Solution	Section
Header or reel not lifting	Appropriate solenoids not being energized by activating switch	Contact Dealer.	Contact Dealer
	Contaminant in relief valve	Clean relief valve at cylinder control valve.	Contact Dealer
Header or reel lifts but lacks power	Relief pressure too low or contaminant in relief valve	Check/adjust/clean relief valve at cylinder control valve.	Contact Dealer
Reel and/or conveyor not turning	HEADER DRIVE switch not engaged	Engage HEADER DRIVE switch.	<a href="#">Engaging and Disengaging the Header, page 203</a>
	Flow controls adjusted too low	Toggle speed controls on CDM to increase flow.	D-Series: <a href="#">4.6.6 Draper Speed, page 263</a> , and <a href="#">4.6.5 Reel Speed, page 260</a> A-Series: <a href="#">4.7.1 Auger Speed, page 272</a> R-Series: <a href="#">4.8.1 Disc Speed, page 280</a>
	Appropriate solenoid on flow control block not being energized	Contact Dealer.	Contact Dealer
Reel and/or conveyor turns but lacks power	Relief pressure too low	Check/adjust/clean relief valve.	Contact Dealer
Hydraulic oil high-temperature alarm	Hydraulic oil cooling system not working properly	Check/clean cooling box.	<a href="#">5.8 Maintaining Engine Cooling Box, page 349</a>
	Faulty bypass valve	Clean or replace.	Contact Dealer
Hydraulic oil low-temperature alarm	Hydraulic oil too cold	Run engine until hydraulic oil warms up.	—

## TROUBLESHOOTING

### 7.4 Header Drive Troubleshooting

Symptom	Problem	Solution	Section
Header drive not engaging	Header DRIVE switch in cab not engaged	Engage HEADER DRIVE switch.	<i>Engaging and Disengaging the Header, page 203</i>
	Operator Presence switch not closed or faulty	Occupy operator's seat or replace switch. Contact your Dealer.	Contact Dealer
	Appropriate solenoid not being energized by activating switch	Contact Dealer.	
Header drive lacks power	Relief valve setting too low		
	Hydraulic couplers/unions not properly connected	Ensure hoses are connected correctly and hose couplers/unions are tight.	Refer to the header operator's manual.
Warning alarm sounds	Header drive overload	Reduce ground speed.	—
	Relief valve setting too low	Contact Dealer.	Contact Dealer

## 7.5 Traction Drive Troubleshooting

Symptom	Problem	Solution	Section
Warning alarm sounds and transmission oil light is on	Low hydraulic oil level	Stop engine, and add oil to hydraulic system.	<a href="#">5.10.1 Checking and Filling Hydraulic Oil, page 389</a>
	Low hydraulic pressure	Contact Dealer.	Contact Dealer
	Foreign material shorting sender		
	Short in alarm wiring		
	Faulty sender		
Wheels lack pulling ability on a grade or pulling out of a ditch	Internal pump or motor damage		
	Insufficient torque at drive wheels	Move ground speed range control to field position, and reduce ground speed.	<a href="#">Driving Forward in Engine-Forward Mode, page 173</a>
	Loose or worn controls	Check controls.	<a href="#">5.5.3 Ground Speed Lever (GSL) Adjustments, page 295</a>
	Air in system	Use proper oil.	<a href="#">8.1.3 Lubricants, Fluids, and System Capacities, page 444</a>
		Check oil level and leaks.	<a href="#">5.10.1 Checking and Filling Hydraulic Oil, page 389</a>
		Check hydraulic oil filters.	<a href="#">5.10 Hydraulic System, page 388</a>
	Brakes binding or not releasing fully	Check pressure on brake release valve (min. 200 psi [1379 kPa]).	Contact Dealer
Relief valve in tandem pump dirty or damaged	Replace relief valve.		
With steering wheel centered, one wheel pulls more than the other	Leakage at pump or motor	Contact Dealer.	Contact Dealer
	Wheels not in same speed range		
	Faulty relief valve	Repair or replace valve. Contact Dealer.	

## TROUBLESHOOTING

Symptom	Problem	Solution	Section
Both wheels will not pull in forward or reverse	Pump arms have broken shaft or loose hardware	Repair or tighten.	Contact Dealer
	Brakes binding or not releasing fully	Check pressure on brake release valve (min. 200 psi [1379 kPa]).	
	Low oil level	Check oil reservoir level.	<a href="#">5.10.1 Checking and Filling Hydraulic Oil, page 389</a>
	Power hubs disengaged	Engage final drives.	<a href="#">Final Drives, page 192</a>
	Damaged hydraulic lines preventing proper oil flow	Replace damaged lines.	Contact Dealer
	Ground speed range control not working	Contact Dealer.	
	Steering controls worn or defective	Check GSL and steering for loose, worn or damaged ball joints and connecting rods.	<a href="#">5.5.3 Ground Speed Lever (GSL) Adjustments, page 295</a> and <a href="#">5.5.4 Steering Adjustments, page 297</a>
	Charge pressure relief valve misadjusted or damaged	Check the valve adjustment. Check valve parts and seat.	<a href="#">Checking Charge Pump Pressure, page 398</a>
	Failed pump or motor	Contact Dealer.	Contact Dealer

## TROUBLESHOOTING

Symptom	Problem	Solution	Section
One wheel does not pull in forward or reverse	Broken pump arm or shaft	Contact Dealer.	Contact Dealer
	One final drive disengaged	Engage final drive.	<a href="#">Final Drives, page 192</a>
	Steering controls worn or defective	Check GSL and steering for loose, worn or damaged ball joints and connecting rods.	<a href="#">5.5.3 Ground Speed Lever (GSL) Adjustments, page 295</a> and <a href="#">5.5.4 Steering Adjustments, page 297</a>
	High pressure relief valve stuck open, damaged seat	Check valve, and clean or replace.	Contact Dealer
	Brakes binding or not releasing fully	Check pressure on brake release valve (min. 200 psi [1379 kPa]).	Contact Dealer
	Damaged hydraulic lines preventing proper oil flow	Contact Dealer.	
	Ground speed range control not working		
	Failed pump, motor or power hub		
Excessive noise from drive system	Mechanical interference in steering or ground speed linkage	Adjust, repair, and replace.	<a href="#">5.5.3 Ground Speed Lever (GSL) Adjustments, page 295</a> and <a href="#">5.5.4 Steering Adjustments, page 297</a>
	Brakes binding or not releasing fully	Check pressure on brake release valve (min. 200 psi [1379 kPa]).	Contact Dealer
	Faulty pump or motor	Contact Dealer.	
	Air in system	Check lines for leakage.	—
	Hydraulic line clamps loose	Tighten clamps.	
Hydraulic oil filter leaks at seal	Not properly tightened	Tighten filter element.	<a href="#">5.10.4 Changing Hydraulic Oil Filters, page 391</a>
	Damaged seal or threads	Replace filter or filter head.	

## TROUBLESHOOTING

### 7.6 Steering and Ground Speed Control Troubleshooting

Symptom	Problem	Solution	Section
Machine will not steer straight	Linkage worn or loose	Adjust steering chain tension. Replace worn parts. Adjust linkage.	<a href="#">5.5.4 Steering Adjustments, page 297</a>
Machine moves on flat ground with controls in neutral	Neutral interlock misadjusted	Contact Dealer.	Contact Dealer
	Parking brake not functioning		
	GSL servo misadjusted		
	GSL cable misadjusted		
Steering wheel will not lock with gsl in n-detent	Transmission interlock misadjusted		
Steering wheel will not unlock	Transmission interlock cylinder not working		
Insufficient road speed	Ground speed range control in field position	Move to road position.	<a href="#">Driving on the Road, page 179</a>
Steering is too stiff or too loose	Steering chain tension is out of adjustment	Adjust steering chain tension.	<a href="#">5.5.4 Steering Adjustments, page 297</a>



## TROUBLESHOOTING

### 7.7 Cab Air Troubleshooting

Symptom	Problem	Solution	Section
Blower fan will not run	Burned out motor	Contact Dealer.	Contact Dealer
	Burned out switch		
	Motor shaft tight or bearings worn		
	Faulty wiring—loose or broken		
	Blower rotors in contact with housing		
Blower fan operating but no air coming into cab	Dirty fresh air filter	Clean fresh air filter.	<a href="#">Cleaning the Engine Air Cleaner's Primary Filter, page 319</a>
	Dirty recirculating air filter	Clean recirculating filter.	<a href="#">Cleaning Return Air Cleaner/Filter, page 304</a>
	Evaporator clogged	Clean evaporator.	<a href="#">Cleaning Air Conditioning (A/C) Evaporator Core, page 305</a>
	Air flow passage blocked	Remove blockage.	—
Heater not heating	Heater shut-off valve at engine closed	Open valve.	<a href="#">3.10.1 Heater Shut-Off, page 56</a>
	Defective thermostat in engine water outlet manifold	Replace thermostat.	Contact Dealer
	Heater temperature control defective	Replace control.	
	No thermostat in engine water outlet manifold	Install thermostat.	
Odor from air louvers	Plugged drainage hose	Blow out hose with compressed air.	—
	Dirty filters	Clean filters.	<a href="#">Cleaning the Engine Air Cleaner's Primary Filter, page 319</a> and <a href="#">Cleaning Return Air Cleaner/Filter, page 304</a>

## TROUBLESHOOTING

Symptom	Problem	Solution	Section
Air conditioning not cooling	Low refrigerant level	Add refrigerant. Contact Dealer.	Contact Dealer
	Clutch coil burned out or disconnected	Contact Dealer.	
	Blower motor disconnected or burned out		
	Switch contacts in thermostat burned excessively, or sensing element defective	Replace thermostat.	
	Compressor partially or completely seized	Remove compressor for service or replacement.	
	Condenser fins plugged	Clean condenser.	<a href="#">5.6.3 Air Conditioning Condenser, page 304</a>
	Loose or broken compressor drive belt	Replace drive belt and/or tighten to specifications.	<a href="#">Tensioning Air Conditioner (A/C) Compressor Belt, page 347</a> and <a href="#">Replacing Air Conditioner (A/C) Compressor Belt, page 347</a>
	Dirty filters	Clean fresh air and recirculation filters.	<a href="#">Cleaning the Engine Air Cleaner's Primary Filter, page 319</a> and <a href="#">Cleaning Return Air Cleaner/Filter, page 304</a>
	Broken or disconnected electrical wire	Check all terminals for loose connections; check wiring for hidden breaks.	—
	Broken or disconnected ground wire	Check ground wire to see if loose, broken, or disconnected.	
	Expansion valve stuck in open or closed position	Contact Dealer.	Contact Dealer
	Broken refrigerant line		
	Leak in system		
Compressor shaft seal leaking			
Clogged screen in receiver-drier; plugged hose or coil			

## TROUBLESHOOTING

Symptom	Problem	Solution	Section
Air conditioning not producing sufficient cooling. (sufficient cooling defined as when air temperature in cab, measured at louvered vent, can be maintained at 25°F [14°C] below ambient air temperature.)	Compressor clutch slipping	Remove clutch assembly for service or replacement.	Contact Dealer
	Thermostat defective or improperly adjusted	Replace thermostat.	
	Clogged air filters	Remove air filters, and clean or replace as necessary.	<a href="#">Cleaning the Engine Air Cleaner's Primary Filter, page 319</a> and <a href="#">Cleaning Return Air Cleaner/Filter, page 304</a>
	Heater circuit is open	Close temperature control in cab, and valve on engine.	<a href="#">3.10.3 Climate Controls, page 57</a> and <a href="#">3.10.1 Heater Shut-Off, page 56</a>
	Insufficient air circulation over condenser coil; fins clogged with dirt or insects	Clean condenser.	<a href="#">5.6.3 Air Conditioning Condenser, page 304</a>
	Evaporator fins clogged	Clean evaporator fins (under cab floor).	<a href="#">Cleaning Air Conditioning (A/C) Evaporator Core, page 305</a>
	Refrigerant low	Contact Dealer.	Contact Dealer
	Clogged expansion valve		
	Clogged receiver-drier		
	Excessive moisture in system		
	Air in system		
Blower motor sluggish in operation			
Air Conditioning Cools Intermittently	Unit icing up due to thermostat adjusted too low	Adjust thermostat.	Contact Dealer
	Unit icing up due to excessive moisture in system	Contact Dealer.	
	Unit icing up due to incorrect super-heat adjustment in the expansion valve		
	Thermostat defective		
	Defective blower switch or blower motor		
	Partially open, improper ground or loose connection in compressor clutch coil		
	Compressor clutch slipping		

## TROUBLESHOOTING

Air Conditioning System Too Noisy	Defective winding or improper connection in compressor clutch coil or relay	Contact Dealer.	Contact Dealer
	Excessive charge in system		
	Low charge in system		
	Excessive moisture in system		
	Loose or excessively worn drive belt	Tighten or replace as required.	<i>Tensioning Air Conditioner (A/C) Compressor Belt, page 347 and Replacing Air Conditioner (A/C) Compressor Belt, page 347</i>
	Noisy clutch	Remove clutch for service or replacement as required.	Contact Dealer
	Noisy compressor	Check mountings and repair. Remove compressor for service or replacement.	
	Compressor oil level low	Add SP-15 PAG refrigerant oil.	
Blower fan noisy due to excessive wear	Remove blower motor for service or replacement as necessary.		
Windows Fog Up	High humidity	Run A/C to dehumidify air and heater to control temperature.	<i>3.10.3 Climate Controls, page 57</i>

## TROUBLESHOOTING

### 7.8 Operator's Station Troubleshooting

Symptom	Problem	Solution	Section
Rough ride	Seat suspension not adjusted for operator's weight	Adjust seat suspension.	<i>3.3 Operator's Seat Adjustments, page 42</i>
Rough ride	High air pressure in tires	Deflate to proper pressure.	<i>Inflating Drive Wheel Tire, page 400 and Inflating Caster Tire, page 406</i>
Rough ride	Cab suspension too stiff	Adjust suspension.	Contact Dealer



## 8 Reference

### 8.1 Recommended Fuel, Fluids, and Lubricants

#### 8.1.1 Storing Lubricants and Fluids

Your machine can only operate at top efficiency if clean fuel and lubricants are used.

- Buy good quality, clean fuel from a reputable dealer.
- Use clean containers to handle fuel and lubricants.
- Keep containers full to avoid condensation issues
- Store in an area protected from dust, moisture, and other contaminants.
- Avoid storing fuel over long periods of time. If you have a slow fuel turnover in the windrower or supply tank, add fuel conditioner to avoid condensation problems.
- Store fuel in a convenient place away from buildings.
- Diesel exhaust fluid (DEF) should be stored in a cool, dry, well ventilated area, out of direct sunlight, on lower shelf or on floor.
- Diesel exhaust fluid (DEF) is corrosive to some metals and should only be stored in polyethylene, polypropylene, or stainless steel containers.
- DEF containers should be sealed to prevent contamination and the evaporation of water which will affect the specified water to urea ratio.
- Diesel fuel should never be mixed with diesel exhaust fluid (DEF).

#### 8.1.2 Fuel Specifications

Use only ultra low sulphur diesel (ULSD) from a reputable supplier. For most year-round service, No.2 ULSD fuel meeting ASTM specification D975 Grade S15 will provide good performance.

If the vehicle is exposed to extreme cold (below 20°F [-7°C]) or is required to operate at colder-than-normal conditions for prolonged periods, use climatized No.2 diesel fuel, or dilute the No.2 ULSD fuel with 50% No.1 ULSD fuel. This will provide better protection from fuel gelling or wax-plugging of the fuel filters.

**Table 8.1 Fuel Specification**

Fuel	Specification	Sulphur (by weight)	Water and Sediment (by volume)	Cetane no. °C	Lubricity
ULSD Grade no. 2	ASTM D975	0.5% maximum	0.05% maximum	40° minimum	520 Microns
ULSD Grade no.1 and 2 mix <sup>44</sup>	n/a	1% maximum 0.5% maximum preferred	0.1% maximum	45–55° cold weather / high altitude	460 Microns

44. Optional when operating temperature is below 32°F (0°C).

## REFERENCE

In extreme situations, when available fuels are of poor quality or problems exist which are peculiar to certain operations, additives can be used. However, the engine manufacturer recommends consultation with the fuel supplier or engine manufacturer before using fuel additives. Situations where additives are useful include:

- A cetane improver additive can be used with low cetane fuels.
- A wax crystal modifier can help with fuels with high cold filter plugging points (CFPP).
- An anti-icer can help prevent ice formation in wet fuel during cold weather.
- An antioxidant or storage stability additive can help with fuel system deposits and poor storage stability.
- A lubricity enhancer can be used to increase the lubricity of fuels so that they meet the requirements given in the table on the previous page. Diesel fuel conditioner is available from your Dealer.

### 8.1.3 Lubricants, Fluids, and System Capacities

#### CAUTION

To avoid injury or death, do not allow ANY machine fluids to enter the body.

**Table 8.2 System Capacities**

Lubricant/Fluid	Location	Description	Capacity
Diesel exhaust fluid (DEF)	Diesel exhaust fluid tank	Must meet ISO 22241 requirements	7.5 US gallons (29 litres)
Grease	As required unless otherwise specified	SAE multi-purpose, high temperature extreme pressure (EP2) performance with 1% max Molybdenum Disulphide (NLGI Grade 2) lithium base	
Diesel fuel	Fuel tank	Ultra low sulphur diesel (ULSD) Grade No.2, or ULSD Grade No.1 and 2 mix <sup>45</sup> ; refer to <a href="#">8.1.2 Fuel Specifications, page 443</a> for more information	97 US gallons (378 liters)
Hydraulic oil	Hydraulic reservoir	SAE 15W-40 compliant with SAE specs for API class SJ and CH-4 engine oil.	17.2 US gallons (65 liters)
Gear lubricant	Gear box	SAE 75W-90, API service class GL-5, fully synthetic gear lubricant, (SAE J2360 preferred)	2.2 US quarts (2.1 liters)
	Wheel drive <sup>46</sup>		1.5 US quarts (1.4 liters)
Antifreeze	Engine cooling system	ASTM D-6210 and Fleetguard ES Compleat® See below	7.3 US gallons (27.5 liters) <sup>47</sup>
Engine oil	Engine oil pan	SAE 15W-40 compliant with SAE specs for API class SJ and CJ-4 Engine Oil	11.6 US quarts (11 liters)

45. Optional when operating temperature is below 32°F (0°C).

46. SAE 85W-140 API Service Class GL-5. Extreme Pressure Gear Lubricant is used before initial change.

47. Equal parts with water, high quality, soft, de-ionized or distilled water as recommended by Supplier.



## REFERENCE

Lubricant/Fluid	Location	Description	Capacity
Air conditioning refrigerant	Air conditioning system	R134A	5 lb (2.27 kg)
Air conditioning refrigerant oil <sup>48</sup>	Air conditioning system total capacity	PAG SP-15	8.1 fl. oz. (240 cc)

If Fleetguard ES Compleat® is unavailable, use a coolant concentrate or prediluted coolant intended for use with heavy duty diesel engines and with a minimum of the following chemical and physical properties:

- Provides cylinder cavitation protection according to fleet study run at or above 60% load capacity.
- Protects the cooling system metals (cast iron, aluminum alloys, and copper alloys such as brass) from corrosion.

The additive package must be part of one of the following coolant mixtures:

- Ethylene glycol or propylene glycol base prediluted (40–60%) heavy duty coolant.
- Ethylene glycol or propylene glycol base heavy duty coolant concentrate in a 40–60% mixture of concentrate with quality water.

Water quality is important to the performance of the cooling system. Distilled, deionized, or demineralized water is recommended for mixing with ethylene glycol and propylene glycol base engine coolant concentrate.

### IMPORTANT:

Do **NOT** use cooling system sealing additives or antifreeze that contains sealing additives.

## 8.1.4 Filter Part Numbers

**Table 8.3 M155E4 Filter Part Numbers**

Filter	Part Number
Engine oil filter	MD #111974
Charge oil filter	MD #112419
Return oil filter	MD #151975
Primary fuel filter element	MD #205028
Secondary fuel filter element	MD #205029
Fuel strainer filter (Breather)	MD #207200
Fuel filler filter	MD #163989
Primary element (Cab)	MD #111060
Primary air filter element	MD #203621
Secondary air filter element	MD #203622
Return air filter	MD #109797
Diesel exhaust fluid (DEF) – tank suction filter	MD #207478
Diesel exhaust fluid (DEF) – vent hose filter	MD #111608
Diesel exhaust fluid (DEF) supply module filter kit	MD #207510

<sup>48</sup>. New compressor (MD #203013) comes filled.

## 8.2 Recommended Torques

### 8.2.1 Torque Specifications

The following tables provide the correct torque values for various bolts, cap screws, and hydraulic fittings.

- Tighten all bolts to the torque values specified in the charts (unless otherwise noted throughout this manual).
- Replace hardware with the same strength and grade of bolt.
- Use the torque value tables as a guide and periodically check tightness of bolts.
- Understand torque categories for bolts and cap screws by using their identifying head markings.

#### SAE Bolt Torque Specifications

Torque values shown in the following tables are valid for non-greased, or non-oiled threads and heads; therefore, do **NOT** grease or oil bolts or cap screws unless otherwise specified in this manual.

**Table 8.4 SAE Grade 5 Bolt and Grade 5 Free Spinning Nut**

Nominal Size (A)	Torque (ft·lbf) (*in·lbf)		Torque (N·m)	
	Min.	Max.	Min.	Max.
1/4-20	*106	*117	11.9	13.2
5/16-18	*218	*241	24.6	27.1
3/8-16	32	36	44	48
7/16-14	52	57	70	77
1/2-13	79	87	106	118
9/16-12	114	126	153	170
5/8-11	157	173	212	234
3/4-10	281	311	380	420
7/8-9	449	496	606	669
1-8	611	676	825	912

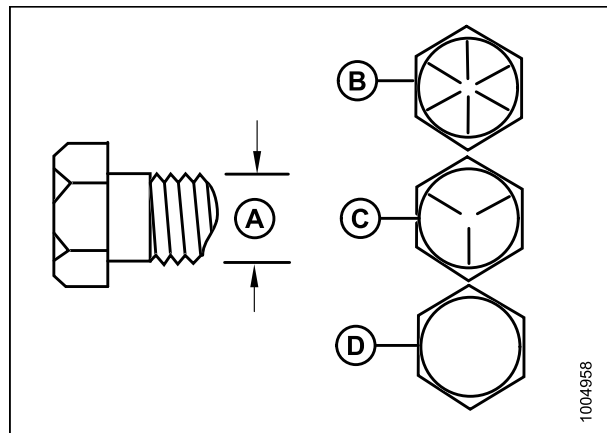

**Figure 8.1: Bolt Grades**

A - Nominal Size  
C - SAE-5

B - SAE-8  
D - SAE-2

1004958

REFERENCE

Table 8.5 SAE Grade 5 Bolt and Grade F Distorted Thread Nut

Nominal Size (A)	Torque (ft·lbf) (*in·lbf)		Torque (N·m)	
	Min.	Max.	Min.	Max.
1/4-20	*72	*80	8.1	9
5/16-18	*149	*164	16.7	18.5
3/8-16	22	24	30	33
7/16-14	35	39	48	53
1/2-13	54	59	73	80
9/16-12	77	86	105	116
5/8-11	107	118	144	160
3/4-10	192	212	259	286
7/8-9	306	338	413	456
1-8	459	507	619	684

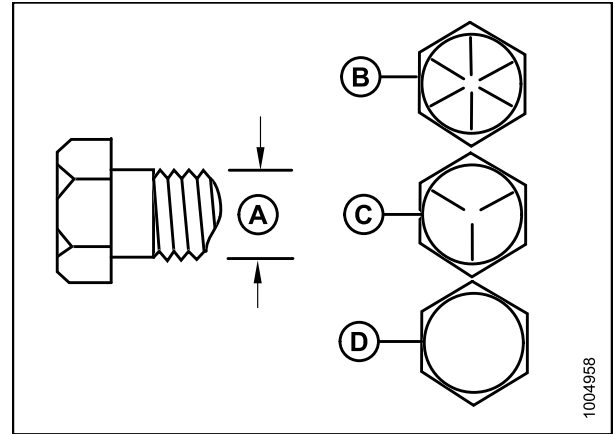

Figure 8.2: Bolt Grades

A - Nominal Size  
 B - SAE-8  
 C - SAE-5  
 D - SAE-2

Table 8.6 SAE Grade 8 Bolt and Grade G Distorted Thread Nut

Nominal Size (A)	Torque (ft·lbf) (*in·lbf)		Torque (N·m)	
	Min.	Max.	Min.	Max.
1/4-20	*150	*165	16.8	18.6
5/16-18	18	19	24	26
3/8-16	31	34	42	46
7/16-14	50	55	67	74
1/2-13	76	84	102	113
9/16-12	109	121	148	163
5/8-11	151	167	204	225
3/4-10	268	296	362	400
7/8-9	432	477	583	644
1-8	647	716	874	966

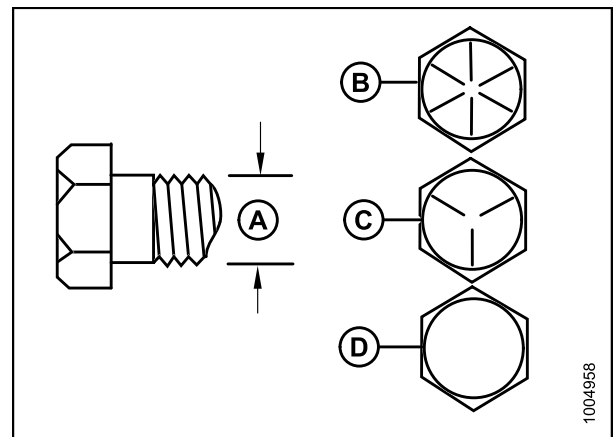

Figure 8.3: Bolt Grades

A - Nominal Size  
 B - SAE-8  
 C - SAE-5  
 D - SAE-2

## REFERENCE

**Table 8.7 SAE Grade 8 Bolt and Grade 8 Free Spinning Nut**

Nominal Size (A)	Torque (ft·lbf) (*in·lbf)		Torque (N·m)	
	Min.	Max.	Min.	Max.
1/4-20	*150	*165	16.8	18.6
5/16-18	26	28	35	38
3/8-16	46	50	61	68
7/16-14	73	81	98	109
1/2-13	111	123	150	166
9/16-12	160	177	217	239
5/8-11	221	345	299	330
3/4-10	393	435	531	587
7/8-9	633	700	855	945
1-8	863	954	1165	1288

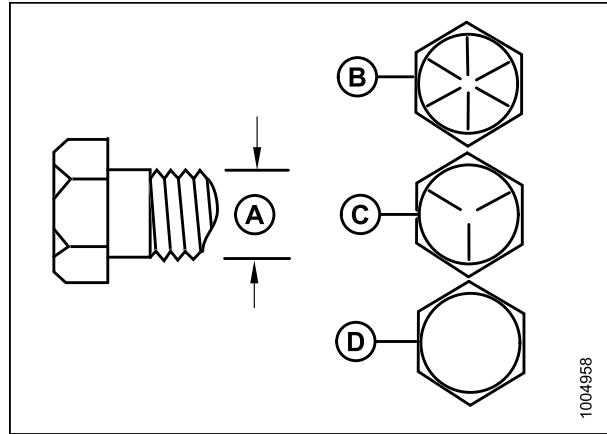

**Figure 8.4: Bolt Grades**

A - Nominal Size  
C - SAE-5

B - SAE-8  
D - SAE-2

### *Metric Bolt Specifications*

**Table 8.8 Metric Class 8.8 Bolts and Class 9 Free Spinning Nut**

Nominal Size (A)	Torque (ft·lbf) (*in·lbf)		Torque (N·m)	
	Min.	Max.	Min.	Max.
3-0.5	*13	*14	1.4	1.6
3.5-0.6	*20	*22	2.2	2.5
4-0.7	*29	*32	3.3	3.7
5-0.8	*59	*66	6.7	7.4
6-1.0	*101	*112	11.4	12.6
8-1.25	20	23	28	30
10-1.5	40	45	55	60
12-1.75	70	78	95	105
14-2.0	113	124	152	168
16-2.0	175	193	236	261
20-2.5	341	377	460	509
24-3.0	589	651	796	879

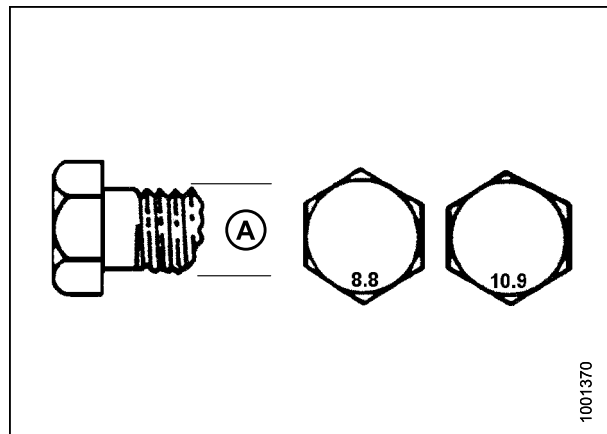

**Figure 8.5: Bolt Grades**

REFERENCE

Table 8.9 Metric Class 8.8 Bolts and Class 9 Distorted Thread Nut

Nominal Size (A)	Torque (ft·lbf) (*in·lbf)		Torque (N·m)	
	Min.	Max.	Min.	Max.
3-0.5	*9	*10	1	1.1
3.5-0.6	*14	*15	1.5	1.7
4-0.7	*20	*22	2.3	2.5
5-0.8	*40	*45	4.5	5
6-1.0	*69	*76	7.7	8.6
8-1.25	*167	*185	18.8	20.8
10-1.5	28	30	37	41
12-1.75	48	53	65	72
14-2.0	77	85	104	115
16-2.0	119	132	161	178
20-2.5	233	257	314	347
24-3.0	402	444	543	600

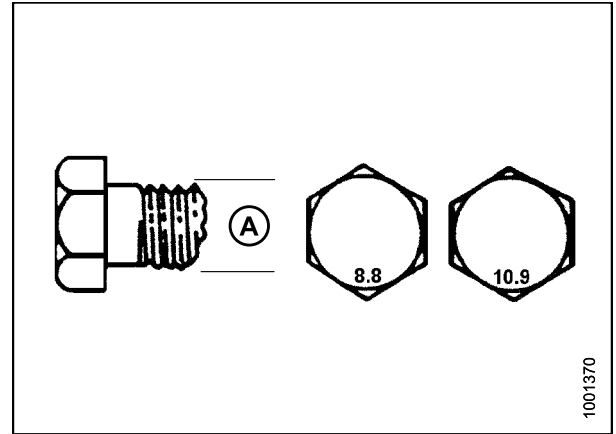

Figure 8.6: Bolt Grades

Table 8.10 Metric Class 10.9 Bolts and Class 10 Free Spinning Nut

Nominal Size (A)	Torque (ft·lbf) (*in·lbf)		Torque (N·m)	
	Min.	Max.	Min.	Max.
3-0.5	*18	*19	1.8	2
3.5-0.6	*27	*30	2.8	3.1
4-0.7	*41	*45	4.2	4.6
5-0.8	*82	*91	8.4	9.3
6-1.0	*140	*154	14.3	15.8
8-1.25	28	31	38	42
10-1.5	56	62	75	83
12-1.75	97	108	132	145
14-2.0	156	172	210	232
16-2.0	242	267	326	360
20-2.5	472	521	637	704
24-3.0	815	901	1101	1217

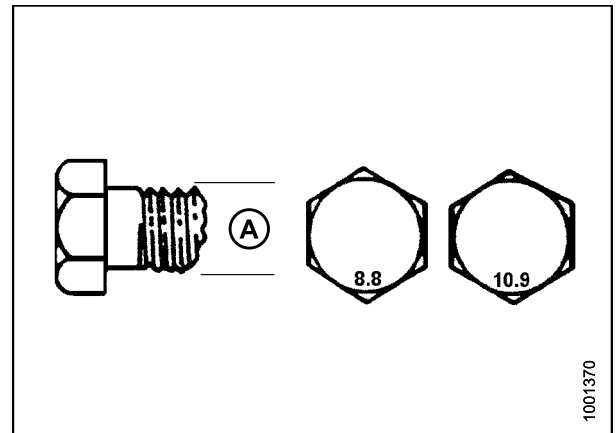
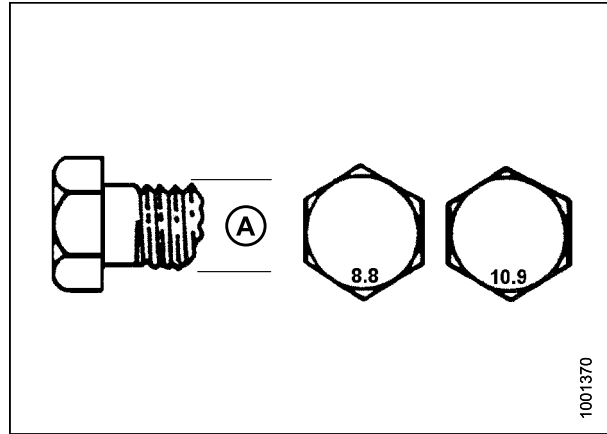

Figure 8.7: Bolt Grades

## REFERENCE

**Table 8.11 Metric Class 10.9 Bolts and Class 10 Distorted Thread Nut**

Nominal Size (A)	Torque (ft·lbf) (*in·lbf)		Torque (N·m)	
	Min.	Max.	Min.	Max.
3-0.5	*12	*13	1.3	1.5
3.5-0.6	*19	*21	2.1	2.3
4-0.7	*28	*31	3.1	3.4
5-0.8	*56	*62	6.3	7
6-1.0	*95	*105	10.7	11.8
8-1.25	19	21	26	29
10-1.5	38	42	51	57
12-1.75	66	73	90	99
14-2.0	106	117	143	158
16-2.0	165	182	222	246
20-2.5	322	356	434	480
24-3.0	556	614	750	829



**Figure 8.8: Bolt Grades**

## REFERENCE

### Metric Bolt Specifications Bolting into Cast Aluminum

**Table 8.12 Metric Bolt Bolting into Cast Aluminum**

Nominal Size (A)	Bolt Torque			
	8.8 (Cast Aluminum)		10.9 (Cast Aluminum)	
	ft·lbf	N·m	ft·lbf	N·m
M3	–	–	1	–
M4	–	–	2.6	4
M5	–	–	5.5	8
M6	6	9	9	12
M8	14	20	20	28
M10	28	40	40	55
M12	52	70	73	100
M14	–	–	–	–
M16	–	–	–	–

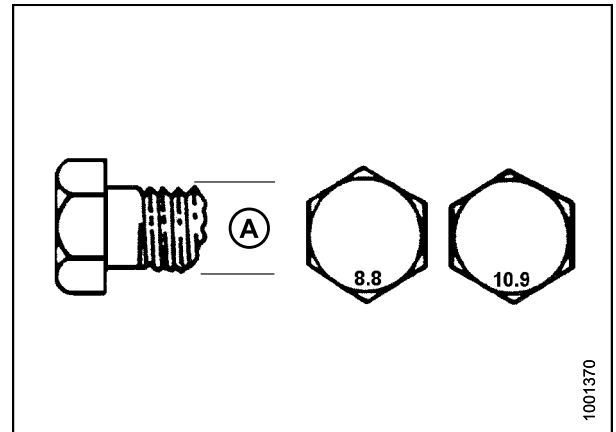

**Figure 8.9: Bolt Grades**

### Flare-Type Hydraulic Fittings

1. Check flare (A) and flare seat (B) for defects that might cause leakage.
2. Align tube (C) with fitting (D) and thread nut (E) onto fitting without lubrication until contact has been made between the flared surfaces.
3. Torque the fitting nut (E) to the specified number of flats from finger tight (FFFT) or to a given torque value in [Table 8.13 Flare-Type Hydraulic Tube Fittings, page 452](#).
4. Use two wrenches to prevent fitting (D) from rotating. Place one wrench on the fitting body (D) and tighten nut (E) with the other wrench to the torque shown.
5. Assess the final condition of the connection.

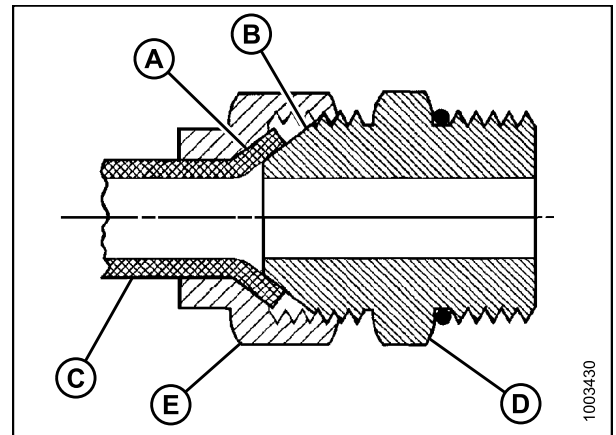

**Figure 8.10: Hydraulic Fitting**

**REFERENCE**

**Table 8.13 Flare-Type Hydraulic Tube Fittings**

SAE Dash Size	Thread Size (in.)	Torque Value <sup>49</sup>		Flats from Finger Tight (FFFT)	
		ft·lbf	N·m	Tube	Swivel Nut or Hose
-2	5/16–24	3–4	4–5	—	—
-3	3/8–24	5–6	7–8	—	—
-4	7/16–20	13–14	18–19	2-1/2	2
-5	1/2–20	14–15	19–21	2	2
-6	9/16–18	22–24	30–33	2	1-1/2
-8	3/4–16	42–46	57–63	2	1-1/2
-10	7/8–14	60–66	81–89	1-1/2	1-1/2
-12	1-1/16–12	83–91	113–124	1-1/2	1-1/4
-14	1-3/16–12	100–110	136–149	1-1/2	1-1/4
-16	1-5/16–12	118–130	160–176	1-1/2	1
-20	1-5/8–12	168–184	228–250	1	1
-24	1-7/8–12	195–215	264–291	1	1
-32	2-1/2–12	265–291	359–395	1	1
-40	3–12	—	—	1	1

49. Torque values shown are based on lubricated connections as in reassembly.



## REFERENCE

### *O-Ring Boss (ORB) Hydraulic Fittings (Adjustable)*

1. Inspect O-ring (A) and seat (B) for dirt or obvious defects.
2. Back off the lock nut (C) as far as possible. Ensure that washer (D) is loose and is pushed toward the lock nut (C) as far as possible.
3. Check that O-ring (A) is **NOT** on the threads and adjust if necessary.
4. Apply hydraulic system oil to the O-ring (A).

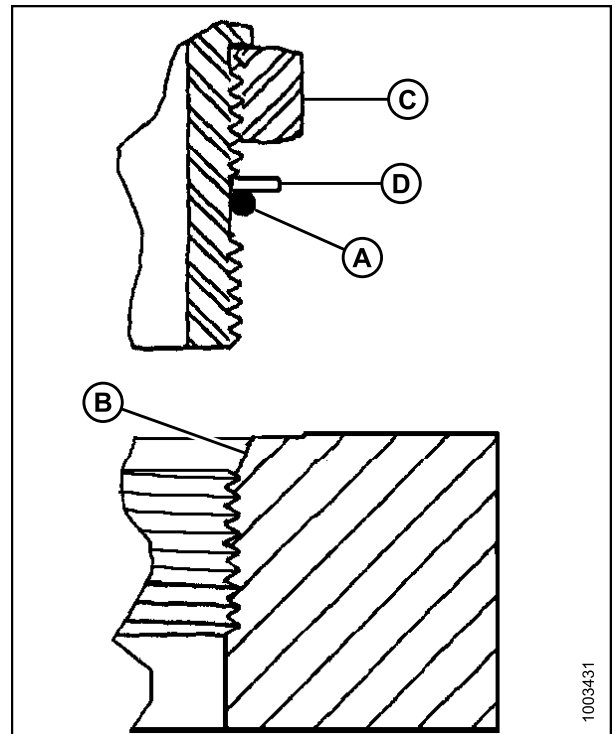

Figure 8.11: Hydraulic Fitting

5. Install fitting (B) into port until back up washer (D) and O-ring (A) contact the part face (E).
6. Position angle fittings by unscrewing no more than one turn.
7. Turn lock nut (C) down to washer (D) and tighten to torque shown. Use two wrenches, one on fitting (B) and the other on lock nut (C).
8. Check the final condition of the fitting.

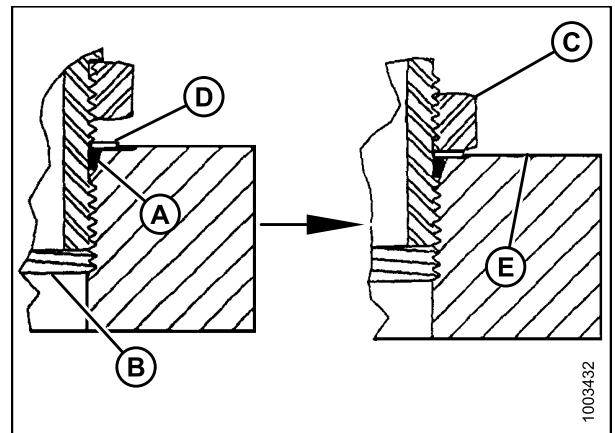

Figure 8.12: Hydraulic Fitting

**REFERENCE**

**Table 8.14 O-Ring Boss (ORB) Hydraulic Fittings (Adjustable)**

SAE Dash Size	Thread Size (in.)	Torque Value <sup>50</sup>	
		ft·lbf (*in·lbf)	N·m
-2	5/16–24	*53–62	6–7
-3	3/8–24	*106–115	12–13
-4	7/16–20	14–15	19–21
-5	1/2–20	15–24	21–33
-6	9/16–18	19–21	26–29
-8	3/4–16	34–37	46–50
-10	7/8–14	55–60	75–82
-12	1-1/16–12	88–97	120–132
-14	1-3/8–12	113–124	153–168
-16	1-5/16–12	130–142	176–193
-20	1-5/8–12	163–179	221–243
-24	1-7/8–12	199–220	270–298
-32	2-1/2–12	245–269	332–365

50. Torque values shown are based on lubricated connections as in reassembly.

## REFERENCE

### *O-Ring Boss (ORB) Hydraulic Fittings (Non-Adjustable)*

1. Inspect O-ring (A) and seat (B) for dirt or obvious defects.
2. Check that O-ring (A) is **NOT** on the threads and adjust if necessary.
3. Apply hydraulic system oil to the O-ring.
4. Install fitting (C) into port until fitting is hand tight.
5. Torque fitting (C) according to the values in Table 8.15 *O-Ring Boss (ORB) Hydraulic Fittings (Non-Adjustable)*, page 455.
6. Check the final condition of the fitting.

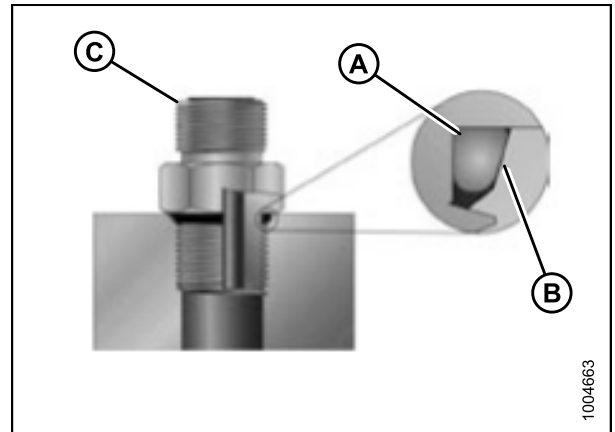

**Figure 8.13: Hydraulic Fitting**

**Table 8.15 O-Ring Boss (ORB) Hydraulic Fittings (Non-Adjustable)**

SAE Dash Size	Thread Size (in.)	Torque Value <sup>51</sup>	
		ft·lbf (*in·lbf)	N·m
-2	5/16–24	*53–62	6–7
-3	3/8–24	*106–115	12–13
-4	7/16–20	14–15	19–21
-5	1/2–20	15–24	21–33
-6	9/16–18	19–21	26–29
-8	3/4–16	34–37	46–50
-10	7/8–14	55–60	75–82
-12	1-1/16–12	88–97	120–132
-14	1-3/8–12	113–124	153–168
-16	1-5/16–12	130–142	176–193
-20	1-5/8–12	163–179	221–243
-24	1-7/8–12	199–220	270–298
-32	2-1/2–12	245–269	332–365

51. Torque values shown are based on lubricated connections as in reassembly.

## REFERENCE

### *O-Ring Face Seal (ORFS) Hydraulic Fittings*

1. Check components to ensure that the sealing surfaces and fitting threads are free of burrs, nicks, scratches, or any foreign material.

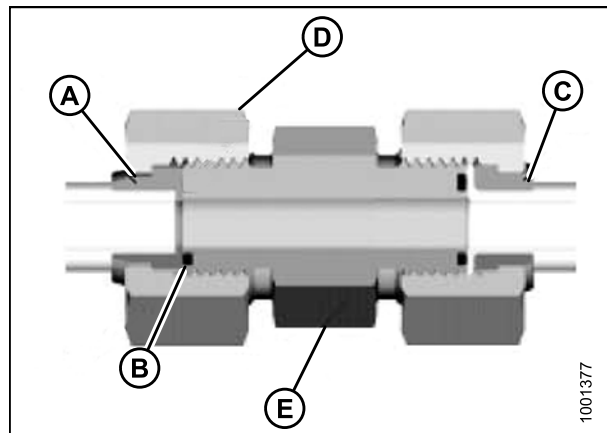

**Figure 8.14: Hydraulic Fitting**

2. Apply hydraulic system oil to the O-ring (B).
3. Align the tube or hose assembly so that the flat face of the sleeve (A) or (C) comes in full contact with O-ring (B).
4. Thread tube or hose nut (D) until hand-tight. The nut should turn freely until it is bottomed out.
5. Torque fittings according to the values in Table [8.16 O-Ring Face Seal \(ORFS\) Hydraulic Fittings, page 457](#).

**NOTE:**

If applicable, hold the hex on the fitting body (E) to prevent rotation of fitting body and hose when tightening the fitting nut (D).



**Figure 8.15: Hydraulic Fitting**

6. Use three wrenches when assembling unions or joining two hoses together.
7. Check the final condition of the fitting.

**REFERENCE**

**Table 8.16 O-Ring Face Seal (ORFS) Hydraulic Fittings**

SAE Dash Size	Thread Size (in.)	Tube O.D. (in.)	Torque Value <sup>52</sup>	
			ft·lbf	N·m
-3	Note <sup>53</sup>	3/16	–	–
-4	9/16	1/4	18–21	25–28
-5	Note <sup>53</sup>	5/16	–	–
-6	11/16	3/8	29–32	40–44
-8	13/16	1/2	41–45	55–61
-10	1	5/8	59–65	80–88
-12	1-3/16	3/4	85–94	115–127
-14	Note <sup>53</sup>	7/8	–	–
-16	1-7/16	1	111–122	150–165
-20	1-11/16	1-1/4	151–167	205–226
-24	1–2	1-1/2	232–256	315–347
-32	2-1/2	2	376–414	510–561

52. Torque values and angles shown are based on lubricated connection as in reassembly.

53. O-ring face seal type end not defined for this tube size.

REFERENCE

### 8.3 Conversion Chart

Table 8.17 Conversion Chart

Quantity	Inch-Pound Units		Factor	SI Units (Metric)	
	Unit Name	Abbreviation		Unit Name	Abbreviation
Area	acres	acres	$\times 0.4047 =$	hectares	ha
Flow	US gallons per minute	gpm	$\times 3.7854 =$	liters per minute	L/min
Force	pounds force	lbf	$\times 4.4482 =$	Newtons	N
Length	inch	in.	$\times 25.4 =$	millimeters	mm
	foot	ft.	$\times 0.305 =$	meters	m
Power	horsepower	hp	$\times 0.7457 =$	kilowatts	kW
Pressure	pounds per square inch	psi	$\times 6.8948 =$	kilopascals	kPa
			$\times .00689 =$	megapascals	MPa
			$\div 14.5038 =$	bar (Non-SI)	bar
Torque	pound feet or foot pounds	ft·lbf	$\times 1.3558 =$	Newton meters	N·m
	pound inches or inch pounds	in·lbf	$\times 0.1129 =$	Newton meters	N·m
Temperature	degrees Fahrenheit	°F	$(^{\circ}\text{F}-32) \times 0.56 =$	Celsius	°C
Velocity	feet per minute	ft/min	$\times 0.3048 =$	meters per minute	m/min
	feet per second	ft/s	$\times 0.3048 =$	meters per second	m/s
	miles per hour	mph	$\times 1.6063 =$	kilometers per hour	km/h
Volume	US gallons	US gal	$\times 3.7854 =$	liters	L
	ounces	oz.	$\times 29.5735 =$	milliliters	ml
	cubic inches	in. <sup>3</sup>	$\times 16.3871 =$	cubic centimeters	cm <sup>3</sup> or cc
Weight	pounds	lb	$\times 0.4536 =$	kilograms	kg

## REFERENCE

### 8.4 Engine Error Codes

The following example explains the segments of an error code:

If the cab display module (CDM) displays the Error Code 629S 12F 28C

629S: S represents the J1939 SPN column. Locate code 629 in that column.

12F: F represents the FMI column. Locate code 12 in that column.

28C: C represents the occurrences (count); 28 is the quantity.

J1939 SPN description: Controller #1. The Cummins description of this is engine control module critical internal failure—Bad intelligent device or component.

The Cummins Dealer will request the fault code that corresponds with the number that you have located in the J1939 SPN column.

Fault Code	J1939 SPN	J1939 FMI	Lamp	J1939 SPN Description	Cummins Description <sup>54</sup>	
2272	27	4	Amber	Engine exhaust gas recirculation 1 valve position	EGR valve position circuit—voltage below normal, or shorted to low source	
6497	51	3	None	Engine intake throttle actuator position sensor circuit	Engine intake throttle actuator position sensor circuit- voltage above normal, or shorted to high source	
6498		4			Engine intake throttle actuator position sensor circuit- voltage above normal, or shorted to low source	
241	84	2	Amber	Wheel-based vehicle speed	Wheel-based vehicle speed—data erratic, intermittent or incorrect	
148	91	0	Red	Accelerator pedal position 1	Accelerator pedal or lever position sensor 1—data valid but above normal operational range—most severe level	
147		1			Accelerator pedal or lever position 1 sensor circuit frequency—data valid but below normal operating range	
1242		2			Accelerator pedal or lever position sensor 1—data erratic, intermittent or incorrect	
131		3			Amber	Accelerator pedal or lever position sensor 1 circuit—voltage above normal, or shorted to high source
1358						Red
132		4			Amber	SAE J1939 multiplexed accelerator pedal or lever sensor system—abnormal update rate
1359						SAE J1939 multiplexed accelerator pedal or lever sensor system—received network data in error
3326		9			Red	
1515		19				

54. These are Cummins descriptions of the J1939 SPN and are subject to change at their discretion.

## REFERENCE

<b>Fault Code</b>	<b>J1939 SPN</b>	<b>J1939 FMI</b>	<b>Lamp</b>	<b>J1939 SPN Description</b>	<b>Cummins Description<sup>54</sup></b>	
546	94	3	Amber	Engine fuel delivery pressure	Fuel delivery pressure sensor circuit—voltage above normal, or shorted to high source	
547		4			Fuel delivery pressure sensor circuit—voltage below normal, or shorted to low source	
2372	95	16	Amber	Engine fuel filter differential pressure	Fuel filter differential pressure—data valid but above normal operating range—moderately severe level	
428	97	3	Amber	Water in fuel indicator	Water in fuel indicator sensor circuit—voltage above normal, or shorted to high source	
429		4			Water in fuel indicator sensor circuit—voltage below normal, or shorted to low source	
418		15	Amber (blinking)		Water in fuel indicator—data valid but above normal operating range—least severe level	
1852		16	Amber		Water in fuel indicator—data valid but above normal operating range—moderately severe level	
415	100	1	Red	Engine oil pressure	Engine oil rifle pressure—data valid but below normal operational range—most severe level	
435		2	Amber		Engine oil rifle pressure—data erratic, intermittent or incorrect	
135		3			Engine oil rifle pressure 1 sensor circuit—voltage above normal, or shorted to high source	
141		4			Engine oil rifle pressure 1 sensor circuit—voltage below normal, or shorted to low source	
143		18			Engine oil rifle pressure—data valid but below normal operating range—moderately severe level	
556	101	0		Red	Engine crankcase pressure	Crankcase pressure—data valid but above normal operational range—most severe level
1942		2	Amber	Crankcase pressure—data erratic, intermittent or incorrect		
1843		3		Crankcase pressure circuit—voltage above normal, or shorted to high source		
1844		4		Crankcase pressure circuit—voltage below normal, or shorted to low source		
1974		15		Amber (blinking)		Crankcase pressure—data valid but above normal operating range—least severe level
555		16		Amber		Crankcase pressure—data valid but above normal operating range—moderately severe level



**REFERENCE**

<b>Fault Code</b>	<b>J1939 SPN</b>	<b>J1939 FMI</b>	<b>Lamp</b>	<b>J1939 SPN Description</b>	<b>Cummins Description<sup>54</sup></b>
122	102	3	Amber	Engine intake manifold #1 pressure	Intake manifold 1 pressure sensor circuit—voltage above normal, or shorted to high source
123		4			Intake manifold 1 pressure sensor circuit—voltage below normal, or shorted to low source
2288	103	15	None	Engine turbocharger 1 speed	Turbocharger 1 speed—data valid but above normal operating range—least severe level
595		16	Amber		Turbocharger 1 speed—data valid but above normal operating range—moderately severe level
687		18			Turbocharger 1 speed—data valid but below normal operating range—moderately severe level
155	105	0	Red	Engine intake manifold 1 temperature	Intake manifold 1 temperature—data valid but above normal operational range—most severe level
153		3	Amber		Intake manifold 1 temperature sensor circuit—voltage above normal, or shorted to high source
154		4			Intake manifold 1 temperature sensor circuit—voltage below normal, or shorted to low source
2964		15	None		Intake manifold 1 temperature—data valid but above normal operating range—least severe level
488		16	Amber		Intake manifold 1 temperature—data valid but above normal operating range—moderately severe level
5576	107	15	Amber	Engine air filter 1 differential pressure	Engine air filter differential pressure—data valid but above normal operating range—least severe level
3341		16			Engine air filter differential pressure—data valid but above normal operating range—moderately severe level

**REFERENCE**

<b>Fault Code</b>	<b>J1939 SPN</b>	<b>J1939 FMI</b>	<b>Lamp</b>	<b>J1939 SPN Description</b>	<b>Cummins Description<sup>54</sup></b>
151	110	0	Red	Engine coolant temperature	Engine coolant temperature—data valid but above normal operational range—most severe level
144		3	Amber		Engine coolant temperature 1 sensor circuit—voltage above normal, or shorted to high source
145		4			Engine coolant temperature 1 sensor circuit—voltage below normal, or shorted to low source
146		16			Engine coolant temperature—data valid but above normal operating range—moderately severe level
2646		31			None
2659					
235	111	1	Red	Engine coolant level	Coolant level—data valid but below normal operational range—most severe level
195		3	Amber		Coolant level sensor 1 circuit—voltage above normal, or shorted to high source
6522			None		
196		4	Amber		Coolant level sensor 1 circuit—voltage below normal, or shorted to low source
6523			None		
2448		17	Amber (blinking)		Coolant level—data valid but below normal operating range—least severe level
197	18	Amber	Coolant level—data valid but below normal operating range—moderately severe level		
449	157	0	Red	Engine injector metering rail 1 pressure	Injector metering rail 1 pressure—data valid but above normal operational range—most severe level
451		3	Amber		Injector metering rail 1 pressure sensor circuit—voltage above normal, or shorted to high source
452		4			Injector metering rail 1 pressure sensor circuit—voltage below normal, or shorted to low source
553		16			Injector metering rail 1 pressure—data valid but above normal operating range—moderately severe level
559		18			
442	168	16	Amber	Battery potential/power input 1	Battery 1 voltage—data valid but above normal operating range—moderately severe level
6256			None		
3724		17	Amber		Battery 1 voltage—data valid but below normal operating range—least severe level
441		18	Amber		Battery 1 voltage—data valid but below normal operating range—moderately severe level
6257			None		

**REFERENCE**

<b>Fault Code</b>	<b>J1939 SPN</b>	<b>J1939 FMI</b>	<b>Lamp</b>	<b>J1939 SPN Description</b>	<b>Cummins Description<sup>54</sup></b>
6524	175	3	None	Engine oil temperature 1	Engine oil temperature sensor 1 circuit—voltage above normal, or shorted to high source
6525		4			Engine oil temperature sensor 1 circuit—voltage below normal, or shorted to low source
234	190	0	Red	Engine speed	Engine crankshaft speed/position—data valid but above normal operational range—most severe level
689		2	Amber		Engine crankshaft speed/position—data erratic, intermittent or incorrect
2321			None		
2468		16	Amber		Engine crankshaft speed/position—data valid but above normal operating range—moderately severe level
4517	237	13	Amber	Vehicle identification number	Vehicle identification number—out of calibration
1866	411	2	Amber	Engine exhaust gas recirculation 1 differential pressure	Exhaust gas recirculation differential pressure—data erratic, intermittent or incorrect
2273		3			Exhaust gas recirculation differential pressure sensor circuit—voltage above normal, or shorted to high source
2274		4			Exhaust gas recirculation differential pressure sensor circuit—voltage below normal, or shorted to low source
2375	412	3	Amber	Engine exhaust gas recirculation 1 temperature	Exhaust gas recirculation temperature sensor circuit—voltage above normal, or shorted to high source
2376		4			Exhaust gas recirculation temperature sensor circuit—voltage below normal, or shorted to low source
2961		15	None		Exhaust gas recirculation temperature—data valid but above normal operating range—least severe level
2962		16	Amber		Exhaust gas recirculation temperature—data valid but above normal operating range—moderately severe level
431	558	2	Amber	Accelerator pedal 1 low idle switch	Accelerator pedal or lever idle validation switch—data erratic, intermittent or incorrect
432		13	Red		Accelerator pedal or lever idle validation switch circuit—out of calibration
3527		19			Accelerator pedal or lever idle validation switch—received network data in error
3488	563	9	Amber	Anti-lock braking (ABS) active	Anti-lock braking (ABS) controller—abnormal update rate
4215		31	None		Anti-lock braking (ABS) active—condition exists

**REFERENCE**

<b>Fault Code</b>	<b>J1939 SPN</b>	<b>J1939 FMI</b>	<b>Lamp</b>	<b>J1939 SPN Description</b>	<b>Cummins Description<sup>54</sup></b>
6563	611	2	None	System diagnostic code #1	Auxiliary intermediate (PTO) speed switch validation—data erratic, intermittent or incorrect
115	612	2	Red	System diagnostic code #2	Engine magnetic speed/position lost both of two signals—data erratic, intermittent or incorrect
291	625	9	Red	Proprietary datalink	Proprietary datalink error (OEM/vehicle datalink)—abnormal update rate
111	629	12	Red	Controller #1	Engine control module critical internal failure—bad intelligent device or component
343			Amber		Engine control module warning internal hardware failure—bad intelligent device or component
3697	630	12	Red	Engine control module calibration memory	Engine control module calibration memory—bad intelligent device or component
2311	633	31	Amber	Engine fuel actuator 1 control command	Electronic fuel injection control valve circuit—condition exists
285	639	9	Amber	J1939 network #1, primary vehicle network (previously SAE J1939 data link)	SAE J1939 multiplexing PGN timeout error—abnormal update rate
4677					SAE J1939 multiplexing configuration error—out of calibration
286					13
2387	641	7	Amber	Engine variable geometry turbocharger actuator #1	VGT actuator driver circuit (motor)—mechanical system not responding or out of adjustment
2636		9	Red		VGT actuator driver circuit—abnormal update rate
2198		11	Amber		VGT actuator driver circuit—root cause not known
2634		12	Red		VGT actuator controller—bad intelligent device or component
1898		13	Amber		VGT actuator controller—out of calibration
2449			Red		
1962		15	Amber		VGT actuator driver over temperature (calculated)—data valid but above normal operating range—least severe level
1976			None		
2635		31	Red		VGT actuator driver circuit—condition exists
237	644	2	Amber	Engine external speed command input	External speed command input (multiple unit synchronization)—data erratic, intermittent or incorrect
2377	647	3	Amber	Engine fan clutch 1 output device driver	Fan control circuit—voltage above normal, or shorted to high source
6263			None		
245		4	Amber		Fan control circuit—voltage below normal, or shorted to low source
6264					

**REFERENCE**

<b>Fault Code</b>	<b>J1939 SPN</b>	<b>J1939 FMI</b>	<b>Lamp</b>	<b>J1939 SPN Description</b>	<b>Cummins Description<sup>54</sup></b>
322	651	5	Amber	Engine injector cylinder #01	Injector solenoid driver cylinder 1 circuit—current below normal or open circuit
331	652	5	Amber	Engine injector cylinder #02	Injector solenoid driver cylinder 2 circuit—current below normal or open circuit
1141		7			Injector solenoid driver cylinder 2—mechanical system not responding or out of adjustment
324	653	5	Amber	Engine injector cylinder #03	Injector solenoid driver cylinder 3 circuit—current below normal or open circuit
1142		7			Injector solenoid driver cylinder 3—mechanical system not responding or out of adjustment
332	654	5	Amber	Engine injector cylinder #04	Injector solenoid driver cylinder 4 circuit—current below normal or open circuit
1143		7			Injector solenoid driver cylinder 4—mechanical system not responding or out of adjustment
323	655	5	Amber	Engine injector cylinder #05	Injector solenoid driver cylinder 5 circuit—current below normal or open circuit
325	656	5	Amber	Engine injector cylinder #06	Injector solenoid driver cylinder 6 circuit—current below normal or open circuit
584	677	3	Amber	Engine starter motor relay	Starter relay driver circuit—voltage above normal, or shorted to high source
585		4			Starter relay driver circuit—voltage below normal, or shorted to low source
2557	697	3	Amber	Auxiliary PWM driver #1	Auxiliary PWM driver 1 circuit—voltage above normal, or shorted to high source
2558		4			Auxiliary PWM driver 1 circuit—voltage below normal, or shorted to low source
4734	701	14	Red	Auxiliary I/O #01	Auxiliary input/output 1—special instructions
778	723	2	Amber	Engine speed 2	Engine Camshaft Speed/Position Sensor—Data erratic, intermittent or incorrect
2322			None		
731		7	Amber		Engine Speed/Position Camshaft and Crankshaft Misalignment—Mechanical system not responding or out of adjustment
2555	729	3	Amber	Engine intake air heater driver #1	Engine intake air heater 1 circuit—voltage above normal, or shorted to high source
6556			None		
2556		4	Amber		Engine intake air heater 1 circuit—voltage below normal, or shorted to low source
6557			None		
3641	748	9	Amber	Transmission output retarder	Transmission output retarder—abnormal update rate

**REFERENCE**

<b>Fault Code</b>	<b>J1939 SPN</b>	<b>J1939 FMI</b>	<b>Lamp</b>	<b>J1939 SPN Description</b>	<b>Cummins Description<sup>54</sup></b>
6336	862	3	None	Crankcase breather heater circuit	Crankcase breather filter heater circuit—voltage above normal, or shorted to high source
6337		4			Crankcase breather filter heater circuit—voltage below normal, or shorted to low source
133	974	3	Red	Remote accelerator pedal position	Remote accelerator pedal or lever position sensor 1 circuit—voltage above normal, or shorted to high source
134		4			Remote accelerator pedal or lever position sensor 1 circuit—voltage below normal, or shorted to low source
288		19			SAE J1939 multiplexing remote accelerator pedal or lever position sensor system—received network data in error
6418	1072	3	None	Engine (compression) brake output #1	Engine brake actuator driver 1 circuit—voltage above normal, or shorted to high source
6419		4			Engine brake actuator driver 1 circuit—voltage below normal, or shorted to low source
6421	1073	3	None	Engine (compression) brake output #2	Engine brake actuator driver output 2 circuit—voltage above normal, or shorted to high source
6422		4			Engine brake actuator driver output 2 circuit—voltage below normal, or shorted to low source
6258	1075	3	None	Engine electric lift pump for engine fuel supply	Electric lift pump for engine fuel supply circuit—voltage above normal, or shorted to high source
6259		4			Electric lift pump for engine fuel supply circuit—voltage below normal, or shorted to low source
3555	1081	9	Amber	Engine wait to start lamp	Engine wait to start lamp—abnormal update rate

**REFERENCE**

<b>Fault Code</b>	<b>J1939 SPN</b>	<b>J1939 FMI</b>	<b>Lamp</b>	<b>J1939 SPN Description</b>	<b>Cummins Description<sup>54</sup></b>
691	1172	3	Amber	Engine turbocharger 1 compressor intake temperature	Turbocharger 1 compressor intake temperature circuit—voltage above normal, or shorted to high source
692		4			Turbocharger 1 compressor intake temperature circuit—voltage below normal, or shorted to low source
743	1176	2	Amber		Turbocharger 1 compressor intake pressure—data erratic, intermittent or incorrect
741		3			Turbocharger 1 compressor intake pressure circuit—voltage above normal, or shorted to high source
742		4			Turbocharger 1 compressor intake pressure circuit—voltage below normal, or shorted to low source
3298	1194	13	Red		Anti-theft encryption seed present indicator
2554	1209	2	Amber	Engine exhaust gas pressure 1	Exhaust gas pressure 1—data erratic, intermittent or incorrect
2373		3			Exhaust gas pressure sensor 1 circuit—voltage above normal, or shorted to high source
2374		4			Exhaust gas pressure sensor 1 circuit—voltage below normal, or shorted to low source
3329	1231	2	None	J1939 network #2	J1939 network #2—data erratic, intermittent or incorrect
3331	1235	2	None	J1939 network #3	J1939 network #3—data erratic, intermittent or incorrect
1654	1323	31	Amber	Engine misfire cylinder #1	Engine misfire cylinder 1—condition exists
1655	1324	31	Amber	Engine misfire cylinder #2	Engine misfire cylinder 2—condition exists
1656	1325	31	Amber	Engine misfire cylinder #3	Engine misfire cylinder 3—condition exists
1657	1326	31	Amber	Engine misfire cylinder #4	Engine misfire cylinder 4—condition exists

**REFERENCE**

<b>Fault Code</b>	<b>J1939 SPN</b>	<b>J1939 FMI</b>	<b>Lamp</b>	<b>J1939 SPN Description</b>	<b>Cummins Description<sup>54</sup></b>
272	1347	3	Amber	Engine fuel pump pressurizing assembly #2	Engine fuel pump pressurizing assembly 1 circuit—voltage above normal, or shorted to high source
271		4		Engine fuel pump pressurizing assembly #1	Engine fuel pump pressurizing assembly 1 circuit—voltage below normal, or shorted to low source
281		7		Engine fuel pump pressurizing assembly #3	Engine fuel pump pressurizing assembly 1—mechanical system not responding or out of adjustment
483	1349	3	Amber	Engine injector metering rail 2 pressure	Injector metering rail 2 pressure sensor circuit—voltage above normal, or shorted to high source
649	1378	31	Amber (blinking)	Engine oil change interval	Engine oil change interval—condition exists
3714	1569		Amber	Engine protection torque derate	Engine protection torque derate—condition exists
4789	1639	0	Amber	Fan Speed	Fan speed—data valid but above normal operational range—most severe level
6467			None		
4791		1	Amber		Fan speed—data valid but below normal operational range—most severe level
6468			None		Fan speed- data erratic, intermittent, or incorrect
	2				
4437	1668	2	None	J1939 network #4—data erratic	J1939 network #4—data erratic, intermittent or incorrect
3737	1675	31	None	Engine starter mode	Engine starter mode overcrank protection—condition exists



**REFERENCE**

<b>Fault Code</b>	<b>J1939 SPN</b>	<b>J1939 FMI</b>	<b>Lamp</b>	<b>J1939 SPN Description</b>	<b>Cummins Description<sup>54</sup></b>
1673	1761	1	Amber	Aftertreatment 1 diesel exhaust fluid tank level	Aftertreatment 1 diesel exhaust fluid tank level—data valid but below normal operational range—most severe level
1669		3			Aftertreatment 1 diesel exhaust fluid tank level sensor circuit—voltage above normal, or shorted to high source
1668		4			Aftertreatment 1 diesel exhaust fluid tank level sensor circuit—voltage below normal, or shorted to low source
4769		10			Aftertreatment 1 diesel exhaust fluid tank level sensor—abnormal rate of change
4739		11			None
6562			Aftertreatment 1 diesel exhaust fluid tank level sensor—out of calibration		
6526		13	Amber (blinking)		Aftertreatment 1 diesel exhaust fluid tank level—data valid but below normal operating range—least severe level
3497		17			Aftertreatment 1 diesel exhaust fluid tank level—data valid but below normal operating range—moderately severe level
3498		18			
1239	2623	3	Amber	Accelerator pedal #1 channel 2	Accelerator pedal or lever position sensor 2 circuit—voltage above normal, or shorted to high source
1241		4			Accelerator pedal or lever position sensor 2 circuit—voltage below normal, or shorted to low source
2346	2789	15	None	Engine turbocharger 1 calculated turbine intake temperature	Turbocharger turbine intake temperature—data valid but above normal operating range—least severe
2349	2791	5	Amber	Engine exhaust gas recirculation 1 (EGR1) valve control	EGR valve control circuit—current below normal or open circuit
2353		6			EGR valve control circuit—current above normal or grounded circuit
2357		7			EGR valve control circuit—mechanical system not responding or out of adjustment
1896		13			EGR valve controller—out of calibration
1961		15			EGR valve control circuit over temperature—data valid but above normal operating range—least severe level

**REFERENCE**

<b>Fault Code</b>	<b>J1939 SPN</b>	<b>J1939 FMI</b>	<b>Lamp</b>	<b>J1939 SPN Description</b>	<b>Cummins Description<sup>54</sup></b>
1679	3031	2	Amber	Aftertreatment 1 diesel exhaust fluid tank temperature	Aftertreatment 1 diesel exhaust fluid tank temperature—data erratic, intermittent or incorrect
1678		3			Aftertreatment 1 diesel exhaust fluid tank temperature sensor—voltage above normal, or shorted to high source
1677		4			None
6559			Aftertreatment 1 diesel exhaust fluid tank temperature—abnormal update rate		
4572		9	Amber		Aftertreatment 1 diesel exhaust fluid tank temperature—abnormal update rate
3228	3216	2	Amber	Aftertreatment 1 intake NOx	Aftertreatment 1 intake NOx sensor—data erratic, intermittent or incorrect
1885		4			Aftertreatment 1 intake NOx sensor circuit—voltage below normal, or shorted to low source
3232		9			Aftertreatment 1 intake NOx sensor—abnormal update rate
3725		10			Aftertreatment 1 intake NOx sensor—abnormal rate of change
3718		13			Aftertreatment 1 intake NOx—out of calibration
3726		16			Aftertreatment 1 intake NOx—data valid but above normal operating range—moderately severe level
3748		20			None
6458			Aftertreatment 1 intake NOx sensor—data not rational—drifted high		
6459			Aftertreatment 1 intake NOx sensor—data not rational—drifted high		
3682		3218	2		Amber

**REFERENCE**

<b>Fault Code</b>	<b>J1939 SPN</b>	<b>J1939 FMI</b>	<b>Lamp</b>	<b>J1939 SPN Description</b>	<b>Cummins Description<sup>54</sup></b>	
1694	3226	2	Amber	Aftertreatment 1 outlet NOx	Aftertreatment 1 outlet NOx sensor—data erratic, intermittent or incorrect	
1887		4			Aftertreatment 1 outlet NOx sensor circuit—voltage below normal, or shorted to low source	
6521			None	Aftertreatment outlet NOx sensor circuits	Aftertreatment outlet NOx sensor circuit- voltage below normal or shorted to low source	
2771		9	Amber	Aftertreatment 1 outlet NOx	Aftertreatment 1 outlet NOx sensor—abnormal update rate	
3545		10	None		Aftertreatment 1 outlet NOx sensor—abnormal rate of change	
6565					Aftertreatment 1 outlet NOx sensor—out of calibration	
3717		13	Amber		20	Aftertreatment 1 outlet NOx sensor—data not rational—drifted high
3749		None				
6462						
6463						
6464						
3681	3228	2	Amber	Aftertreatment 1 outlet gas sensor power status	Aftertreatment 1 outlet NOx sensor power supply—data erratic, intermittent or incorrect	
3319	3246	3	Amber	Aftertreatment 1 diesel particulate filter outlet gas temperature	Aftertreatment 1 diesel particulate filter outlet temperature sensor circuit—voltage above normal, or shorted to high source	
2976	3361	2	Amber	Aftertreatment 1 diesel exhaust fluid supply module	Aftertreatment 1 diesel exhaust fluid supply module temperature—data erratic, intermittent or incorrect	
3558		3			Aftertreatment 1 diesel exhaust fluid supply module—voltage above normal, or shorted to high source	
3559		4			Aftertreatment 1 diesel exhaust fluid supply module—voltage below normal, or shorted to low source	
1682	3362	31	Amber	Aftertreatment 1 diesel exhaust fluid supply module input lines	Aftertreatment 1 diesel exhaust fluid supply module input lines—condition exists	

**REFERENCE**

<b>Fault Code</b>	<b>J1939 SPN</b>	<b>J1939 FMI</b>	<b>Lamp</b>	<b>J1939 SPN Description</b>	<b>Cummins Description<sup>54</sup></b>
1683	3363	3	Amber	Aftertreatment 1 diesel exhaust fluid tank 1 heater	Aftertreatment 1 diesel exhaust fluid tank heater—voltage above normal, or shorted to high source
6479			None		
1684		4	Amber		Aftertreatment 1 diesel exhaust fluid tank heater—voltage below normal, or shorted to low source
6481			None		
3242		7	Amber		Aftertreatment 1 diesel exhaust fluid tank heater—mechanical system not responding or out of adjustment
6475			None		
1713		16	Amber		Aftertreatment 1 diesel exhaust fluid tank heater—data valid but above normal operating range—moderately severe level
1712		18			
6476			None		Aftertreatment 1 diesel exhaust fluid tank heater—data valid but below normal operating range—moderately severe level

**REFERENCE**

<b>Fault Code</b>	<b>J1939 SPN</b>	<b>J1939 FMI</b>	<b>Lamp</b>	<b>J1939 SPN Description</b>	<b>Cummins Description<sup>54</sup></b>
3878	3364	2	Amber	Aftertreatment 1 diesel exhaust fluid tank 1 quality	Aftertreatment diesel exhaust fluid quality—data erratic, intermittent or incorrect
1686		3			Aftertreatment diesel exhaust fluid quality sensor circuit—voltage above normal, or shorted to high source
1685		4			Aftertreatment diesel exhaust fluid quality sensor circuit—voltage below normal, or shorted to low source
4741		5			Aftertreatment diesel exhaust fluid quality sensor circuit—current below normal or open circuit
4742		6			Aftertreatment diesel exhaust fluid quality sensor circuit—current above normal or grounded circuit
3876		7			Aftertreatment diesel exhaust fluid quality sensor—mechanical system not responding or out of adjustment
3868		9			Aftertreatment diesel exhaust fluid quality—abnormal update rate
4277		10			Aftertreatment diesel exhaust fluid quality—abnormal rate of change
1715		11			Aftertreatment diesel exhaust fluid quality—root cause not known
1714		13			Aftertreatment diesel exhaust fluid quality—out of calibration
4842		3464			15
3867	18		Amber	Aftertreatment 1 diesel exhaust fluid tank 1 quality	Aftertreatment diesel exhaust fluid quality—data valid but below normal operating range—moderate severe level
4241	19				Aftertreatment diesel exhaust fluid quality—received network data in error
6493	3509		3	None	Electronic throttle control actuator driver circuit
6496		4			
386	3509	3	Amber	Sensor supply voltage 1	Sensor supply 1 circuit—voltage above normal, or shorted to high source
352		4			Sensor supply 1 circuit—voltage below normal, or shorted to low source

**REFERENCE**

<b>Fault Code</b>	<b>J1939 SPN</b>	<b>J1939 FMI</b>	<b>Lamp</b>	<b>J1939 SPN Description</b>	<b>Cummins Description<sup>54</sup></b>
227	3510	3	Amber	Sensor supply voltage 2	Sensor supply 2 circuit—voltage above normal, or shorted to high source
187		4			Sensor supply 2 circuit—voltage below normal, or shorted to low source
239	3511	3	Amber	Sensor supply voltage 3	Sensor supply 3 circuit—voltage above normal, or shorted to high source
238		4			Sensor supply 3 circuit—voltage below normal, or shorted to low source
2185	3512	3	Amber	Sensor supply voltage 4	Sensor supply 4 circuit—voltage above normal, or shorted to high source
2186		4			Sensor supply 4 circuit—voltage below normal, or shorted to low source
1695	3513	3	Amber	Sensor supply voltage 5	Sensor supply 5—voltage above normal, or shorted to high source
1696		4			Sensor supply 5—voltage below normal, or shorted to low source
515	3514	3	Amber	Sensor supply voltage 6	Sensor supply 6 circuit—voltage above normal, or shorted to high source
516		4			Sensor supply 6 circuit—voltage below normal, or shorted to low source
4743	3515	5	Amber	Aftertreatment 1 diesel exhaust fluid temperature 2 sensor circuit	Aftertreatment 1 diesel exhaust fluid temperature 2 sensor circuit—current below normal or open circuit
4744		6			Aftertreatment 1 diesel exhaust fluid temperature 2 sensor circuit—current above normal or grounded
4243		10			Aftertreatment 1 diesel exhaust fluid temperature 2—abnormal rate of change
4745		11			Aftertreatment 1 diesel exhaust fluid temperature 2—root cause not known
4768	3521	11	Amber	Aftertreatment 1 diesel exhaust fluid property	Aftertreatment 1 diesel exhaust fluid property—root cause not known
1117	3597	2	None	ECU power output supply voltage #1	Power supply lost with ignition on—data erratic, intermittent or incorrect
351		12	Amber		Injector power supply—bad intelligent device or component
1938		18	None		ECU power output supply voltage 1—data valid but below normal operating range—moderately severe level
6499		18			

**REFERENCE**

<b>Fault Code</b>	<b>J1939 SPN</b>	<b>J1939 FMI</b>	<b>Lamp</b>	<b>J1939 SPN Description</b>	<b>Cummins Description<sup>54</sup></b>
6553	3610	2	None	Aftertreatment diesel particulate filter outlet pressure	Aftertreatment 1 diesel particulate filter outlet pressure—data erratic, intermittent or incorrect
6551		3			Aftertreatment 1 diesel particulate filter outlet pressure sensor circuit—voltage above normal, or shorted to high source
6552		4			Aftertreatment 1 diesel particulate filter outlet pressure sensor circuit—voltage below normal, or shorted to low source
4213	3695	2	Amber	Aftertreatment regeneration inhibit switch	Aftertreatment regeneration inhibit switch—data erratic, intermittent or incorrect
6568		2	None		
6265	3936	7	None	Aftertreatment 1 diesel particulate filter system	Aftertreatment 1 diesel particulate filter system—mechanical system not responding or out of adjustment
3547	4096	31	Amber	NOx limits exceeded due to empty diesel exhaust fluid tank	Aftertreatment diesel exhaust fluid tank empty—condition exists
1427	4185	31	Amber	Overspeed shutdown relay driver	Overspeed shutdown relay driver diagnostic has detected an error—condition exists
1428	4186	31	Amber	Low oil pressure shutdown relay driver	Low oil pressure (LOP) shutdown relay driver diagnostic has detected an error—condition exists
1429	4187	31	Amber	High engine temperature shutdown relay driver	High engine temperature (HET) shutdown relay driver diagnostic has detected an error—condition exists
1431	4188	31	Amber	Pre-low oil pressure indicator relay driver	Pre-low oil pressure warning relay driver diagnostic has detected an error—condition exists
1432	4223	31	Amber	Pre-high engine temperature warning relay driver	Pre-high engine temperature warning relay driver diagnostic has detected an error—condition exists

**REFERENCE**

<b>Fault Code</b>	<b>J1939 SPN</b>	<b>J1939 FMI</b>	<b>Lamp</b>	<b>J1939 SPN Description</b>	<b>Cummins Description<sup>54</sup></b>	
3596	4334	2	Amber	Aftertreatment 1 diesel exhaust fluid pressure	Aftertreatment 1 diesel exhaust fluid pressure sensor—data erratic, intermittent or incorrect	
3571		3			Aftertreatment 1 diesel exhaust fluid pressure sensor—voltage above normal, or shorted to high source	
3572		4			Aftertreatment 1 diesel exhaust fluid pressure sensor—voltage below normal, or shorted to low source	
3575		16			Aftertreatment 1 diesel exhaust fluid pressure sensor—data valid but above normal operating range	
3574		18			Aftertreatment 1 diesel exhaust fluid pressure sensor—data valid but below normal operating range	
4249	4337	10	Amber	Aftertreatment 1 diesel exhaust fluid dosing temperature	Aftertreatment 1 diesel exhaust fluid dosing temperature—abnormal rate of change	
3237	4340	3	Amber	Aftertreatment 1 diesel exhaust fluid line heater 1 state	Aftertreatment 1 diesel exhaust fluid line heater 1 circuit—voltage above normal, or shorted to high source	
6531			None			
3238		4	Amber		Aftertreatment 1 diesel exhaust fluid line heater 1 circuit—voltage below normal, or shorted to low source	
6532			None			
3258		5	Amber		Aftertreatment 1 diesel exhaust fluid line heater 1 circuit—current below normal or open circuit	
6482			None			
3239	4342	3	Amber	Aftertreatment 1 diesel exhaust fluid line heater 2 state	Aftertreatment 1 diesel exhaust fluid line heater 2 circuit—voltage above normal, or shorted to high source	
6533			None			
3241		4	Amber		Aftertreatment 1 diesel exhaust fluid line heater 2 circuit—voltage below normal, or shorted to low source	
6534			None			
3261		5	Amber		Aftertreatment 1 diesel exhaust fluid line heater 2 circuit—current below normal or open circuit	
6483			None			
3422	4344	3	Amber	Aftertreatment 1 diesel exhaust fluid line heater 3 state	Aftertreatment diesel exhaust fluid line heater 3 circuit—voltage above normal, or shorted to high source	
6535					4	Aftertreatment diesel exhaust fluid line heater 3 circuit—voltage below normal, or shorted to low source
3423		5				Aftertreatment diesel exhaust fluid line heater 3 circuit—current below normal or open circuit
6536						
3425		None				
6484						



**REFERENCE**

<b>Fault Code</b>	<b>J1939 SPN</b>	<b>J1939 FMI</b>	<b>Lamp</b>	<b>J1939 SPN Description</b>	<b>Cummins Description<sup>54</sup></b>
3229	4360	0	Red	Aftertreatment 1 SCR catalyst intake gas temperature	Aftertreatment 1 SCR intake temperature—data valid but above normal operational range—most severe level
3144		2	Amber		Aftertreatment 1 SCR intake temperature sensor—data erratic, intermittent or incorrect
3142		3			Aftertreatment 1 SCR intake temperature sensor circuit—voltage above normal, or shorted to high source
3143		4			Aftertreatment 1 SCR intake temperature sensor circuit—voltage below normal, or shorted to low source
3164		15	None		Aftertreatment 1 SCR intake temperature—data valid but above normal operating range—least severe
3231		16	Red		Aftertreatment 1 SCR intake temperature—data valid but above normal operating range—moderately severe level
3165	4363	0	Red	Aftertreatment 1 SCR catalyst outlet gas temperature	Aftertreatment 1 SCR outlet temperature—data valid but above normal operational range—most severe
3148		2	Amber		Aftertreatment 1 SCR outlet temperature sensor—data erratic, intermittent or incorrect
3146		3	None		Aftertreatment 1 SCR outlet temperature sensor circuit—voltage above normal, or shorted to high source
6569			Amber		Aftertreatment 1 SCR outlet temperature sensor circuit—voltage below normal, or shorted to low source
3147		4	None		Aftertreatment 1 SCR outlet temperature—data valid but above normal operating range—moderately severe level
6571			Red		Aftertreatment 1 SCR outlet temperature—data valid but above normal operating range—moderately severe level
3235	16	Red	Aftertreatment 1 SCR outlet temperature—data valid but above normal operating range—moderately severe level		
3582	4364	18	Amber	Aftertreatment 1 SCR conversion efficiency	Aftertreatment SCR catalyst conversion efficiency—data valid but below normal operating range—moderately severe level
6517			None		
3577	4376	3	Amber	Aftertreatment 1 diesel exhaust fluid return valve	Aftertreatment diesel exhaust fluid return valve—voltage above normal, or shorted to high source
3578		4			Aftertreatment diesel exhaust fluid return valve—voltage below normal, or shorted to low source
4157		7	None		Aftertreatment diesel exhaust fluid return valve—mechanical system not responding or out of adjust
6527					None

**REFERENCE**

<b>Fault Code</b>	<b>J1939 SPN</b>	<b>J1939 FMI</b>	<b>Lamp</b>	<b>J1939 SPN Description</b>	<b>Cummins Description<sup>54</sup></b>
3315	4765	2	Amber	Aftertreatment diesel oxidation catalyst intake temperature	Aftertreatment 1 diesel oxidation catalyst intake temperature—data erratic, intermittent or incorrect
6539			None		
3314		3	Amber		Aftertreatment 1 diesel oxidation catalyst intake temperature sensor circuit—voltage above normal, or shorted to high source
3313					
3251		16	Red		Aftertreatment 1 diesel oxidation catalyst intake temperature—data valid but above normal operating range
5387	4766	0	Amber	Aftertreatment 1 diesel oxidation catalyst outlet gas temperature	Aftertreatment 1 diesel oxidation catalyst outlet gas temperature—data valid but above normal operating range—most severe level
5386		2			Aftertreatment 1 diesel oxidation catalyst outlet gas temperature—data erratic, intermittent, or incorrect
4533		3		Aftertreatment 1 diesel oxidation catalyst outlet gas temperature sensor circuit	Aftertreatment 1 diesel oxidation catalyst outlet gas temperature sensor circuit—voltage above normal, or shorted to high source
4534		4			Aftertreatment 1 diesel oxidation catalyst outlet gas temperature sensor circuit—voltage below normal, or shorted to low source
5389		15		Aftertreatment 1 diesel oxidation catalyst outlet gas temperature	Aftertreatment 1 diesel oxidation catalyst outlet gas temperature—data valid but above normal operating range—least severe level
5388		16		Red	Aftertreatment 1 diesel oxidation catalyst outlet gas temperature
3751	4792	7	None	Aftertreatment SCR catalyst system	Aftertreatment SCR catalyst system—mechanical system not responding or out of adjustment
3151	4794	31	Amber	Aftertreatment 1 SCR catalyst system	Aftertreatment 1 SCR catalyst system missing—condition exists
1664	4796	31	Amber	Aftertreatment 1 diesel oxidation catalyst missing	Aftertreatment 1 diesel oxidation catalyst missing—condition exists
2637	5018	11	None	Aftertreatment diesel oxidation catalyst	Aftertreatment 1 diesel oxidation catalyst face plugged—root cause not known
3649	5024	10	Amber	Aftertreatment 1 intake gas NOx sensor heater ratio	Aftertreatment 1 intake NOx sensor heater—abnormal rate of change

**REFERENCE**

<b>Fault Code</b>	<b>J1939 SPN</b>	<b>J1939 FMI</b>	<b>Lamp</b>	<b>J1939 SPN Description</b>	<b>Cummins Description<sup>54</sup></b>
3583	5031	10	Amber	Aftertreatment 1 outlet gas NOx sensor heater ratio	Aftertreatment 1 outlet NOx sensor heater—abnormal rate of change
6581			None		
3419	5125	3	Amber	Sensor supply voltage 7	Sensor supply 7 circuit—voltage above normal, or shorted to high source
3421		4			Sensor supply 7 circuit—voltage below normal, or shorted to low source
3712	5246	0	Red	Aftertreatment SCR operator inducement severity	Aftertreatment SCR operator inducement—data valid but above normal operational range—most severe level
1691	5298	18	Amber	Aftertreatment 1 diesel oxidation catalyst conversion efficiency	Aftertreatment 1 diesel oxidation catalyst conversion efficiency—data valid but below normal operating range—moderately severe level
2638			None		
3755	5394	2	None	Aftertreatment diesel exhaust fluid dosing valve	Aftertreatment diesel exhaust fluid dosing valve—data erratic, intermittent or incorrect
3567		5	Amber		Aftertreatment diesel exhaust fluid dosing valve—current below normal or open circuit
3568		7			Aftertreatment diesel exhaust fluid dosing valve—mechanical system not responding or out of adjustment
3633	5484	3	Amber	Engine fan clutch 2 output device driver	Engine fan clutch 2 control circuit—voltage above normal, or shorted to high source
6456			None		
3634		4	Amber		Engine fan clutch 2 control circuit—voltage below normal, or shorted to low source
6457			None		
3562	5491	3	Amber	Aftertreatment 1 diesel exhaust fluid line heater relay	Aftertreatment diesel exhaust fluid line heater relay—voltage above normal, or shorted to high source
6477			None		
3563		4	Amber		Aftertreatment diesel exhaust fluid line heater relay—voltage below normal, or shorted to low source
6478			None		
6537		7	None		Aftertreatment 1 diesel exhaust fluid line heater relay—mechanical system not responding or out of adjustment
3741	5571	0	Amber	High pressure common rail fuel pressure relief valve	High pressure common rail fuel pressure relief valve—data valid but above normal operational range
3727		7	None		High pressure common rail fuel pressure relief valve—mechanical system not responding or out of adjustment
5585		15	Amber		High pressure common rail fuel pressure relief valve—data valid but above normal operating range—least severe level

**REFERENCE**

<b>Fault Code</b>	<b>J1939 SPN</b>	<b>J1939 FMI</b>	<b>Lamp</b>	<b>J1939 SPN Description</b>	<b>Cummins Description<sup>54</sup></b>
4161	5742	3	Amber	Aftertreatment diesel particulate filter temperature sensor module	Aftertreatment diesel particulate filter temperature sensor module—voltage above normal, or shorted to high source
4162		4			Aftertreatment diesel particulate filter temperature sensor module—voltage below normal, or shorted to low source
4151		9			Aftertreatment diesel particulate filter temperature sensor module—abnormal update rate
4158		12			Aftertreatment diesel particulate filter temperature sensor module—bad intelligent device or component
4163		16			Aftertreatment diesel particulate filter temperature sensor module- data valid but above normal operating range
4152	5743	9	Amber	Aftertreatment selective catalytic reduction temperature sensor module	Aftertreatment selective catalytic reduction temperature sensor module—abnormal update rate
4164		3			Aftertreatment selective catalytic reduction temperature sensor module—voltage above normal, or shorted to high source
4165		4			Aftertreatment selective catalytic reduction temperature sensor module—voltage below normal, or shorted to low source
4261		11			Aftertreatment selective catalytic reduction temperature sensor module—root cause not known
4159		12			Aftertreatment selective catalytic reduction temperature sensor module—bad intelligent device or component
4166		16			Aftertreatment selective catalytic reduction temperature sensor module—data valid but above normal
4168	5745	3	Amber	Aftertreatment 1 Diesel Exhaust Fluid supply Module Heater	Aftertreatment 1 Diesel Exhaust Fluid supply Module Heater—Voltage Above Normal, or Shorted to High
4169		4			Aftertreatment 1 Diesel Exhaust Fluid supply Module Heater—Voltage below normal, or shorted to low source
4171		18			None
6513					

**REFERENCE**

<b>Fault Code</b>	<b>J1939 SPN</b>	<b>J1939 FMI</b>	<b>Lamp</b>	<b>J1939 SPN Description</b>	<b>Cummins Description<sup>54</sup></b>
4155	5746	3	Amber	Aftertreatment 1 Diesel Exhaust Fluid supply Module Heater Relay	Aftertreatment 1 Diesel Exhaust Fluid supply Module Heater Relay—Voltage Above Normal, or Shorted to high source
6529			None		
4156		4	Amber		Aftertreatment 1 Diesel Exhaust Fluid supply Module Heater Relay—Voltage below normal, or shorted to low source
4251	5798	10	Amber	Aftertreatment 1 diesel exhaust fluid supply module heater temperature	Aftertreatment 1 diesel exhaust fluid supply module heater temperature—abnormal rate of change
6511	6655	3	None	ECU power lamp	Maintain ECU power lamp—voltage above normal, or shorted to high source
6512		4			Maintain ECU power lamp—voltage below normal, or shorted to low source
5278	6802	31	Amber		Aftertreatment 1 diesel exhaust fluid dosing system frozen—condition exists
5653	6881	9	Amber	SCR operator inducement override switch	SCR operator inducement override switch—abnormal update rate
5654		13			SCR operator inducement override switch—out of calibration
5393	6882	3	Amber	Aftertreatment diesel oxidation catalyst temperature sensor module	Aftertreatment diesel oxidation catalyst temperature sensor module—voltage above normal or shorted to high source
5394		4			Aftertreatment diesel oxidation catalyst temperature sensor module—voltage below normal or shorted to low source
5391		9			Aftertreatment diesel oxidation catalyst temperature sensor module—abnormal update rate
5395		11			Aftertreatment diesel oxidation catalyst temperature sensor module—root cause not known
5392		12			Aftertreatment diesel oxidation catalyst temperature sensor module—bad intelligent device or component
5396		16			Aftertreatment diesel oxidation catalyst temperature sensor module—data valid but above normal operating range—moderately severe level
5632	6918	31	Maintenance	SCR system cleaning inhibited due to inhibit switch	SCR system cleaning inhibited due to inhibit switch—condition exists

**REFERENCE**

<b>Fault Code</b>	<b>J1939 SPN</b>	<b>J1939 FMI</b>	<b>Lamp</b>	<b>J1939 SPN Description</b>	<b>Cummins Description<sup>54</sup></b>
5631	6928	31	None	SCR system cleaning inhibited due to system timeout	SCR system cleaning inhibited due to system timeout—condition exists
6597			Amber		
5183	520784	3	Amber	Fan blade pitch position sensor circuit	Fan blade pitch position sensor circuit—voltage above normal, or shorted to high source
6471			None		
5184		4	Amber	Fan blade pitch position sensor circuit	Fan blade pitch position sensor circuit—voltage below normal, or shorted to low source
6472			None		
5185		5	Amber	Fan blade pitch	Fan blade pitch—mechanical system not responding or out of adjustment
6473			None		
5939	520968	9	Amber		Machine constrained operation- abnormal update rate. No communication or an invalid data transfer rate has been detected on the J1939 data link between the ECM and the machine electronic control unit
5941		19	None		Machine constrained operation- received network data in error. The received J1939 datalink message was not valid
5617	524286	31	Amber	Aftertreatment 1 diesel oxidation catalyst system	Aftertreatment 1 diesel oxidation catalyst system-special instruction

REFERENCE

## 8.5 Diesel Exhaust Fluid (DEF) Supply Module Fault Codes

SPN	FMI	Description
3361	2	Diesel Exhaust Fluid Dosing Unit Temperature - Data Erratic, Intermittent, or Incorrect
3361	3	Diesel Exhaust Fluid Dosing Unit - Voltage Above Normal or Shorted to High Source
3559	4	Diesel Exhaust Fluid Dosing Unit - Voltage Below Normal or Shorted to Low Source
5746	3	Diesel Exhaust Fluid Dosing Unit Heater Relay - Voltage Above Normal or Shorted to High Source
5746	4	Diesel Exhaust Fluid Dosing Unit Heater Relay - Voltage Below Normal or Shorted to Low Source
4376	7	Diesel Exhaust Fluid Return Valve - Mechanical System Not Responding or Out of Adjustment
4376	3	Diesel Exhaust Fluid Return Valve - Voltage Above Normal or Shorted to High Source
4376	4	Diesel Exhaust Fluid Return Valve - Voltage Below Normal or Shorted to Low Source
5745	3	Diesel Exhaust Fluid Dosing Unit Heater - Voltage Above Normal or Shorted to High Source
5745	4	Diesel Exhaust Fluid Dosing Unit Heater - Voltage Below Normal or Shorted to Low Source
5745	18	Diesel Exhaust Fluid Dosing Unit Heater - Data Valid But Below Normal Operating Range
4337	3	Diesel Exhaust Fluid Dosing Temperature Sensor - Voltage Above Normal or Shorted to High
4337	4	Diesel Exhaust Fluid Dosing Temperature Sensor - Voltage Below Normal or Shorted to Low
5798	2	Diesel Exhaust Fluid Dosing Unit Heater Temperature - Data Erratic, Intermittent, or Incorrect
4337	10	Diesel Exhaust Fluid Dosing Temperature - Abnormal Rate of Change
5798	10	Diesel Exhaust Fluid Dosing Unit Heater Temperature - Abnormal Rate of Change
5394	7	Diesel Exhaust Fluid Dosing Valve - Mechanical System Not Responding or Out of Adjustment
4334	3	Diesel Exhaust Fluid Pressure Sensor - Voltage Above Normal or Shorted to High Source
4334	4	Diesel Exhaust Fluid Pressure Sensor - Voltage Below Normal or Shorted to Low Source
4334	18	Diesel Exhaust Fluid Pressure Sensor - Data Valid But Below Normal Operating Range
4334	16	Diesel Exhaust Fluid Pressure Sensor - Data Valid But Above Normal Operating Range
4094	31	NOx Limits Exceeded Due to Insufficient Reagent Quality - Condition Exists
3361	2	Diesel Exhaust Fluid Dosing Unit Temperature - Data Erratic, Intermittent, or Incorrect
3361	3	Diesel Exhaust Fluid Dosing Unit - Voltage Above Normal or Shorted to High Source
3559	4	Diesel Exhaust Fluid Dosing Unit - Voltage Below Normal or Shorted to Low Source

## REFERENCE

5746	3	Diesel Exhaust Fluid Dosing Unit Heater Relay - Voltage Above Normal or Shorted to High Source
5746	4	Diesel Exhaust Fluid Dosing Unit Heater Relay - Voltage Below Normal or Shorted to Low Source
4376	7	Diesel Exhaust Fluid Return Valve - Mechanical System Not Responding or Out of Adjustment
4376	3	Diesel Exhaust Fluid Return Valve - Voltage Above Normal or Shorted to High Source
4376	4	Diesel Exhaust Fluid Return Valve - Voltage Below Normal or Shorted to Low Source
5745	3	Diesel Exhaust Fluid Dosing Unit Heater - Voltage Above Normal or Shorted to High Source
5745	4	Diesel Exhaust Fluid Dosing Unit Heater - Voltage Below Normal or Shorted to Low Source
5745	18	Diesel Exhaust Fluid Dosing Unit Heater - Data Valid But Below Normal Operating Range
4337	3	Diesel Exhaust Fluid Dosing Temperature Sensor - Voltage Above Normal or Shorted to High
4337	4	Diesel Exhaust Fluid Dosing Temperature Sensor - Voltage Below Normal or Shorted to Low
5798	2	Diesel Exhaust Fluid Dosing Unit Heater Temperature - Data Erratic, Intermittent, or Incorrect
4337	10	Diesel Exhaust Fluid Dosing Temperature - Abnormal Rate of Change
5798	10	Diesel Exhaust Fluid Dosing Unit Heater Temperature - Abnormal Rate of Change
5394	7	Diesel Exhaust Fluid Dosing Valve - Mechanical System Not Responding or Out of Adjustment
4334	3	Diesel Exhaust Fluid Pressure Sensor - Voltage Above Normal or Shorted to High Source
4334	4	Diesel Exhaust Fluid Pressure Sensor - Voltage Below Normal or Shorted to Low Source
4334	18	Diesel Exhaust Fluid Pressure Sensor - Data Valid But Below Normal Operating Range
4334	16	Diesel Exhaust Fluid Pressure Sensor - Data Valid But Above Normal Operating Range
4094	31	NOx Limits Exceeded Due to Insufficient Reagent Quality - Condition Exists



**REFERENCE**

## **8.6 Diesel Exhaust Fluid (DEF) Tank and Sensor Associated Fault Codes**

SPN	FMI	Description
1761	4	DEF Tank Level Sensor Circuit – Voltage Below Normal or Shorted to Low Source
1761	3	DEF Tank Level Sensor Circuit – Voltage Above Normal or Shorted to High Source
1761	5	DEF Tank Level Sensor Circuit – Current Below Normal or Open Circuit
1761	1	DEF Tank Level – Data Valid but Below Normal Operating Range – Most Severe Level
1761	17	DEF Tank Level – Data Valid but Below Normal Operating Range – Least Severe Level
1761	18	DEF Tank Level – Data Valid but Below Normal Operating Range – Moderately Severe Level
1761	6	DEF Tank Level – Current Above Normal or Grounded Circuit
1761	11	DEF Tank Level – Root Cause Not Known
1761	10	DEF Tank Level – Abnormal Rate of Change
1761	2	DEF Tank Level – Data Erratic, Intermittent, or Incorrect
1761	13	DEF Tank Level – Out of Calibration
3031	4	DEF Tank Temperature Sensor – Voltage Below Normal or Shorted to Low Source
3031	3	DEF Tank Temperature Sensor – Voltage Above Normal or Shorted to High Source
3031	2	DEF Tank Temperature Sensor – Data Erratic, Intermittent, or Incorrect
3031	6	DEF Tank Temperature Sensor – Current Above Normal or Grounded Circuit
3031	9	DEF Tank Temperature Sensor – Abnormal Update Rate
3031	11	DEF Tank Temperature – Root Cause Not Known
3031	5	DEF Tank Temperature Sensor – Current Below Normal or Open Circuit
3031	13	DEF Tank Temperature Sensor – Out of Calibration
3363	3	DEF Tank Heater – Voltage Above Normal or Shorted to High Source
3363	4	DEF Tank Heater – Voltage Below Normal or Shorted to Low Source
3363	18	DEF Tank Heater – Data Valid but Below Normal Operating Range – Moderately Severe Level
3363	16	DEF Tank Heater – Data Valid but Above Normal Operating Range – Moderately Severe Level
3363	7	DEF Tank Heater – Mechanical System Not Responding or Out of Adjustment
3364	1	DEF Tank Quality Sensor – Data Valid but Below Normal Operating Range – Most Severe Level
3364	18	DEF Tank Quality Sensor – Data Valid but Below Normal Operating Range – Moderately Severe
3364	5	DEF Tank Quality Sensor – Current Below Normal or Open Circuit
3364	6	DEF Tank Quality Sensor – Current Above Normal or Grounded Circuit
3364	4	DEF Tank Quality Sensor – Voltage Below Normal or Shorted to Low Source
3364	3	DEF Tank Quality Sensor – Voltage Above Normal or Shorted to High Source

## REFERENCE

3364	13	DEF Tank Quality Sensor – Out of Calibration
3364	9	DEF Tank Quality Sensor – Abnormal Update Rate
3364	11	DEF Tank Quality Sensor – Root Cause Not Known
3364	7	DEF Tank Quality Sensor – Mechanical System Not Responding or Out of Adjustment
3364	12	DEF Tank Quality Sensor – Bad Intelligent Device or Component
3364	2	DEF Tank Quality Sensor – Data Erratic, Intermittent, or Incorrect
3364	10	DEF Tank Quality Sensor – Abnormal Rate of Change
4094	31	NOx Limits Exceeded Due to Insufficient Regent Quality – Condition Exists
4096	31	DEF Tank Empty – Condition Exists
1761	4	DEF Tank Level Sensor Circuit – Voltage Below Normal or Shorted to Low Source
1761	3	DEF Tank Level Sensor Circuit – Voltage Above Normal or Shorted to High Source
1761	5	DEF Tank Level Sensor Circuit – Current Below Normal or Open Circuit
1761	1	DEF Tank Level – Data Valid but Below Normal Operating Range – Most Severe Level
1761	17	DEF Tank Level – Data Valid but Below Normal Operating Range – Least Severe Level
1761	18	DEF Tank Level – Data Valid but Below Normal Operating Range – Moderately Severe Level
1761	6	DEF Tank Level – Current Above Normal or Grounded Circuit
1761	11	DEF Tank Level – Root Cause Not Known
1761	10	DEF Tank Level – Abnormal Rate of Change
1761	2	DEF Tank Level – Data Erratic, Intermittent, or Incorrect
1761	13	DEF Tank Level – Out of Calibration
3031	4	DEF Tank Temperature Sensor – Voltage Below Normal or Shorted to Low Source
3031	3	DEF Tank Temperature Sensor – Voltage Above Normal or Shorted to High Source
3031	2	DEF Tank Temperature Sensor – Data Erratic, Intermittent, or Incorrect
3031	6	DEF Tank Temperature Sensor – Current Above Normal or Grounded Circuit
3031	9	DEF Tank Temperature Sensor – Abnormal Update Rate
3031	11	DEF Tank Temperature – Root Cause Not Known
3031	5	DEF Tank Temperature Sensor – Current Below Normal or Open Circuit
3031	13	DEF Tank Temperature Sensor – Out of Calibration
3363	3	DEF Tank Heater – Voltage Above Normal or Shorted to High Source
3363	4	DEF Tank Heater – Voltage Below Normal or Shorted to Low Source
3363	18	DEF Tank Heater – Data Valid but Below Normal Operating Range – Moderately Severe Level
3363	16	DEF Tank Heater – Data Valid but Above Normal Operating Range – Moderately Severe Level
3363	7	DEF Tank Heater – Mechanical System Not Responding or Out of Adjustment
3364	1	DEF Tank Quality Sensor – Data Valid but Below Normal Operating Range – Most Severe Level

## REFERENCE

3364	18	DEF Tank Quality Sensor – Data Valid but Below Normal Operating Range – Moderately Severe
3364	5	DEF Tank Quality Sensor – Current Below Normal or Open Circuit
3364	6	DEF Tank Quality Sensor – Current Above Normal or Grounded Circuit
3364	4	DEF Tank Quality Sensor – Voltage Below Normal or Shorted to Low Source
3364	3	DEF Tank Quality Sensor – Voltage Above Normal or Shorted to High Source
3364	13	DEF Tank Quality Sensor – Out of Calibration
3364	9	DEF Tank Quality Sensor – Abnormal Update Rate
3364	11	DEF Tank Quality Sensor – Root Cause Not Known
3364	7	DEF Tank Quality Sensor – Mechanical System Not Responding or Out of Adjustment
3364	12	DEF Tank Quality Sensor – Bad Intelligent Device or Component
3364	2	DEF Tank Quality Sensor – Data Erratic, Intermittent, or Incorrect
3364	10	DEF Tank Quality Sensor – Abnormal Rate of Change
4094	31	NOx Limits Exceeded Due to Insufficient Regent Quality – Condition Exists
4096	31	DEF Tank Empty – Condition Exists

REFERENCE

## 8.7 Troubleshooting Diesel Exhaust Fluid (DEF) System

Symptom	Cause	Action
Engine cranks, but fails to run	No fuel No power	Check fuel level Check fuel supply to pump inlet Verify air intake is clear of debris Confirm 12V between ignition pin 5 and ground when key is in the ON position
DEF Supply Module fails to prime or purge		Check DEF tank level Check connection on DEF supply module. Detach and inspect connection for contamination or damage Check DEF lines to and from the DEF dosing module for signs of leakage. DEF forms a white deposit around leaking fittings. Replace if necessary Remove and inspect DEF lines for clogging. Soak in warm water to remove blockages
Aftertreatment DEF dosing module—mechanical system not responding		Removing the DEF injector, and clean gently with warm water, removing crystallized DEF
Multiplexing errors		Confirm functionality of the auxiliary display If display is not functioning, update software before replacing display. Refer to <a href="#">Updating Software for the Fuel/Diesel Exhaust Fluid (DEF) Display 2015 and Prior</a> Check CAN wiring continuity between the display and OEM crossover connector P175
Aftertreatment sensor (NOx level, DOC temp, SCR temp)		Ensure connector to the sensor in question is plugged in and locking tabs are locked Check continuity of the sensor in question to aftertreatment datalink at P175 (OEM crossover connector) Confirm power supply and ground to sensor in question If continuity check fails, locate discontinuity and repair/replace harness (MD #202550)
Several simultaneous aftertreatment Codes		Possible the aftertreatment CAN datalink network had gone down. The network itself should sit at 60 Ohms across the datalink high and low Check the resistance across pins 22 and 23 of P175 (OEM crossover connector) network. Unplug the 24 pin connector to do so, 120 Ohms should be the resistance reading of an intact CAN wiring system on the windrower side with key OFF. Alternately, the resistance can be measured without unplugging the connector, and should then read 60 Ohms

## REFERENCE

Symptom	Cause	Action
DEF Tank Empty, causing system derate		Fill tank using approved DEF
DEF Tank Sensor wiring damage/Unplugged, causing system derate		Check sensor connection on the DEF Tank. Inspect connection for contamination or damage
DEF Quality Inadequate, causing system derate		Ensure Diesel Exhaust Fluid meets ISO 22241-1 / DIN 70070 standards and has not been contaminated
System out NO <sub>x</sub> high, causing system derate		DEF Tank Empty. Fill using approved DEF Urea flow inadequate. Inspect tank and supply module filters. Replace if necessary. Inspect DEF lines for clogging. Soak in warm water to remove blockages

REFERENCE

## 8.8 Cab Display Module (CDM)/Windrower Control Module (WCM) Error Codes

### 8.8.1 Cab Display Module (CDM) Error Codes

**NOTE:**

In the case of dual codes being shown for an item (primarily the solenoid valves), the first code indicates a SHORT CIRCUIT condition, while the second code indicates an OPEN CIRCUIT condition. That is, E41 would be a SHORT in the Reel Aft solenoids (P55, P59), while E141 would indicate an OPEN circuit.

Codes	CDM Display	Description
E1		
E2	RTCH NOT ALLOWED	Return to cut height activated with the header off
E3	CDM CAN BUS ERROR	E3 is triggered when the CDM module can not transmit and/or receive CAN bus. Check CAN signals on pin 22, 23, 24 and the power ground on 9, 11 and 25 in connector P38. If all signals check out OK, check CAN bus cabling and end bus terminations in place. The terminators are located behind the Cab Display Module (CDM) connector P41, and near the engine Electronic Control Module (ECM) connector P40. The resistance should be 120 ohm resistance
E4	HDR DRV NOT ALLOWED	Header engage switch activated while in engine-forward
E5	CHECK HEADER ID	Header ID change has been detected while the header was engaged
E6	TEMP GAUGE SHORT	Wiring/connection problem
E7	SPEED STICK SHORT	Wiring/connection problem
E8	HEADER ENABLE SHORT	Wiring/connection problem
E9	WCM ENABLE SHORT	Wiring/connection problem
E10	CDM INTERNAL ERROR	A generic internal CDM error summarizing a number of internal problems
E11	CDM POWER UP	Indicates that the voltage on CDM connector P38, pin 26 is too low or the ground connections are loose; could be a wiring issue
E12	WCM POWER UP	E12 indicates that the voltage on WCM connector P34, pin 2 is too low or the ground on pin 9 is loose; could be a wiring issue
E13	FUEL SOLENOID	WCM fuel solenoid output fault detected
E14		
E15	KNIFE DRIVE PWM P68	Knife drive – PWM solenoid P68 drive fault detected
E16	DRAPER DRIVE PWM P69	Draper drive – PWM solenoid P69 drive fault detected
E17	REEL DRIVE PWM P70	Reel drive – PWM solenoid P70 drive fault detected
E18		

## REFERENCE

Codes		CDM Display	Description
E19	E119	Load Sense P75	Disc block valve – Solenoid P75 drive fault detected — short circuit/open circuit
E20			
E21	E121	REVERSER P106	Reverser solenoid P106 fault detected — short circuit/open circuit
E22			
E23	E123	REVERSER	Reverser solenoids (P65, P66, P67) fault detected — short circuit/open circuit
E24	E124	DECK SHFT RIGHT P95	Right deck shift solenoid P95 fault detected — short circuit/open circuit
E25	E125	DECK SHFT LEFT P96	Left Deck Shift solenoid P96 fault detected — short circuit/open circuit
E26	E126	DWA UP	DWA raise solenoid P72, P73 fault detected — short circuit/open circuit
E27	E127	DWA DOWN	DWA lower solenoid P72, P73, fault detected circuit — short circuit/open circuit
E28	E128	TILT RETRACT	Header tilt retract solenoid P54, fault detected — short circuit/open circuit
E29	E129	TILT EXTEND	Header tilt extend solenoid P53, P54, fault detected — short circuit/open circuit
E30	E130	4 WAY VALVE P62	Four-way valve solenoid P62 fault detected — short circuit/open circuit
E31	E131	BYPASS VALVE P52	Bypass valve solenoid P52 fault detected — short circuit/open circuit
E32	E132	HEADER UP/DOWN P57	Header up/down solenoid P57, fault detected — short circuit/open circuit
E33	E133	SCREEN CLEANERS	Screen cleaner output fault detected — short circuit/open circuit
E34	E134	RIGHT STOP LAMP	Right stop lamp output fault detected — short circuit/open circuit
E35	E135	LEFT STOP LAMP	Left stop lamp output fault detected — short circuit/open circuit
E36	E136	RIGHT TURN LAMP	Right turn lamp output fault detected — short circuit/open circuit
E37	E137	LEFT TURN LAMP	Left turn lamp output fault detected — short circuit/open circuit
E38	E138	MAIN DRIVE	Main header drive solenoid P71 fault detected — short circuit/open circuit
E39	E139	LOW RANGE P61	Low range solenoid P61 fault detected — short circuit/open circuit
E40	E140	HIGH RANGE P60	High range solenoid P60 fault detected — short circuit/open circuit

## REFERENCE

Codes		CDM Display	Description
E41	E141	REEL AFT	Reel aft solenoid P55, P59, fault detected — short circuit/open circuit
E42	E142	REEL FORE	Reel fore solenoid P55, P59, fault detected — short circuit/open circuit
E43	E143	REEL UP/DOWN P58	Reel up/down solenoid P58 fault detected — short circuit/open circuit
E44	E144	FLOAT RHS P64	RHS float solenoid P64, fault detected — short circuit/open circuit
E45	E145	FLOAT LHS P63	LHS float solenoid P63, fault detected — short circuit/open circuit
E46		SENSOR VOLTS HIGH	WCM's 9V Sensor voltage output high
E47		SENSOR VOLTS LOW	WCM's 9V Sensor voltage output low
E48		WCM OVER TEMP	E49 the temp limits are set to -10C and +85C representing the board temp read by the chip inside the WCM module; this is to protect the module when operating at extreme temp; the WCM outputs will stop working (they stay off) when the board temp is below -20C or above 120C; the high temp may indicate a strong/ massive short circuit in the cabling on the WCM outputs
E49		WCM LOW TEMP	WCM low temp fault
E50		BATT+ OUT OF RANGE	System voltage above 15.5 VDC
E51	E151	DISK DRIVE PWM P68	Disk header drive solenoid P68 fault detected — short circuit/open circuit
E52			
E53			
E54			
E55		DISK SPD OVERLOAD	Low disk speed detected < setpoint
Error codes E56 to E63 not allocated			
E64			
E65		KNIFE OVERLOAD	Low knife speed detected < setpoint
E66		### LOW VOLTS	Low system voltage <11.5 VDC
E67			
E68		HYDRAULIC OIL HOT	Oil tank temp >230°F/110°C
E69		ENGINE AIR FILTER	Engine air filter plugged
E70		HYDRAULIC FILTER	Hydraulic filter pressure too high (MD #139722)
E71			
E72		### HIGH VOLTS	System voltage above 15.5 VDC
Error codes E73 to E100 not allocated			



## REFERENCE

Codes		CDM Display	Description
E101		SPI ERROR	Indicates that the communication between the two micros inside the WCM module is not working properly; could be resolved by re-programming the WCM
E102		CAN ERROR	E102 is detected by the WCM module so the issue is related to the CAN bus signals on the WCM end; it may happen when the CDM sees the engine ECU but not the WCM (not hooked up or experiencing power or CAN bus problems; may also happen if the CDM connector P38, pin 8 signal is malfunctioning or the wire between the CDM connector P38, pin 8 and WCM connector P36, pin 30 is not making a proper connection). The wire at the CDM is CB60 and at the WCM CH60
E103		EEPROM READ ERROR	Internal errors specific to the WCM; try re-programming the module
E104		EEPROM WRITE ERROR	Internal errors specific to the WCM; try re-programming the module
E105		TEMP SENSOR ERROR	Internal errors specific to the WCM; try re-programming the module

### 8.8.2 Miscellaneous Information / Error Codes

CDM Display	Description
Engine Oil Pressure	Engine oil pressure warning
Engine Temperature	Engine coolant temperature warning
WCM Not on CAN BUS (displayed for English) Error CAN BUS (displayed for Spanish and Russian)	This error is triggered after turning the ignition <b>ON</b> . If the CDM cannot establish any communication with the WCM module. This is part of the power up self test, and locks the system showing this error for as long as condition remains valid.
Knife Spd Overload	Low knife speed detected (less than programmed overload speed)
No Operator	Operator not detected in seat (~3 second delay before message)
No Header	No header ID detected – not hooked up or wiring error
Lock Seat Base	Seat base not detected in either Cab or engine-forward position
Disengage Header	Header engage switch on when ignition turned on
xxxxS xxF xxC	Engine Error code configuration (Canbus) – Refer to <a href="#">8.4 Engine Error Codes, page 459</a>
Center Steering	Ground speed lever (GSL) or Pintle switches not closed with the key on / engine off
Not in Park	GSL or Pintle switches not closed with the key on / engine off
Brake on	Engine running GSL out of “PARK” brake is still engaged
Place GSL into “N”	GSL or Pintle switches not closed with the key on / engine off
Brake Sw Failure	Ignition on / engine not running – brake switch and relay closed

## REFERENCE

CDM Display	Description
Brake Off	Engine running, GSL in N-DETENT, brake pressure switch or brake switch relay fault
Check Seat Switches	System detects that both seat switches are active. If both switches are detected to be activated then the display will alternately flash between these two messages
Cab-Forward Sw on	
Eng-Forward Sw on	

# Index

## A

A-Series headers	
A30-D	
auger speed .....	272
knife speed “on the go” .....	279
A30-S, A30-D	
reel speed .....	273
A40-D	
auger speed .....	272
knife speed “on the go” .....	279
reel only speed .....	274
reel speed .....	274
reel speed while moving .....	275
reel to ground speed .....	276
attaching an A-Series header .....	229
attaching header with hydraulic center-link and optional self-alignment kit .....	230
auger speed .....	272
knife speed .....	278
air conditioning, See HVAC system	
alarms	
fuel and diesel exhaust fluid (DEF) display module .....	70
antenna mountings .....	62
API	
definitions .....	27
assembly	
connecting batteries .....	361
installing drive wheel .....	403
ASTM	
definitions .....	27
auger speeds .....	272
A30-D header .....	272
A40-D header .....	272
auto raise height feature .....	210
programming auto raise height .....	210
using auto raise height feature .....	211
automated steering .....	419

## B

batteries	
adding electrolyte .....	358
boosting .....	358
charging .....	356
connecting .....	361
installing .....	360
main disconnect switch .....	355
maintaining .....	354
removing .....	359
belts	

A/C compressor belt	
replacing .....	347
tensioning .....	347
alternator/fan belt	
tensioning .....	345
replacing alternator/fan belt .....	345

## C

cab display module (CDM)	
calibrating header sensors	
header float sensor .....	104
header height sensor .....	99
header tilt sensor .....	102
CDM display settings	
backlighting .....	97
buzzer volume .....	96
contrast .....	98
display language .....	94
windrower speed .....	95
CDM/WCM fault codes .....	154
displaying locked CDM buttons .....	130
engine and windrower functions .....	79
engine error codes .....	154, 459
engine warning lights .....	89
header functions .....	80
locking CDM buttons	
auger speed .....	125
draper speed .....	124
header float .....	122
header tilt .....	128
knife speed .....	120
reel fore-aft .....	127
reel speed .....	126
rotary disc speed .....	121
operating screens .....	81
programming .....	93
auger reel speed .....	117
auto raise height .....	115
double windrower attachment (DWA) .....	113
drive manifold .....	113
engine intermediate speed control (ISC) .....	119
hay conditioner .....	116
header cut width .....	113
header index mode .....	111
hydraulic center-link .....	106
hydraulic overload pressure .....	110
knife overload speed .....	108
knife speed .....	107
return to cut mode .....	112

## INDEX

- rotary disc hydraulics..... 106
  - rotary disc overload speed..... 109
  - tire size ..... 118
  - troubleshooting
    - activating hydraulic purge ..... 143
    - forcing a Header ID ..... 136
    - header sensors ..... 133
    - sensor input signals ..... 134
    - testing double windrower attachment (DWA) ..... 152
    - testing draper drive ..... 147
    - testing header tilt ..... 141
    - testing header up/down ..... 137
    - testing knife drive ..... 145
    - testing reel drive ..... 149
    - testing reel fore-aft ..... 142
    - testing reel up/down function ..... 139
    - testing rotary disc drive..... 150
    - windrower error codes
      - engine error codes..... 131
    - warning/alarms..... 89
  - cab suspension limit straps ..... 300
  - cab temperature, *See* HVAC system
  - California proposition 65..... 2
  - CanWin
    - cab display module (CDM)
      - error codes ..... 490
      - service tool
        - clearing sub-acres ..... 120
  - CanWin service tool
    - cab display module (CDM)
      - information/error codes..... 493
  - CDM, *See* cab display module (CDM)
  - center-links ..... 27
    - See also* hydraulic links
    - definitions ..... 27
    - self-locking center-link hook mechanism ..... 205
  - circuit breakers
    - accessing ..... 381
    - replacing..... 382
  - climate control system, *See* HVAC system
  - climate controls ..... 57
  - component locations ..... 36
  - consoles ..... 39
  - conversion charts ..... 458
  - cutting height..... 207
- D**
- D-Series headers
    - attaching..... 214
      - header boots ..... 214
    - deck shift ..... 269
      - setting float options ..... 269
  - definitions ..... 27
  - draper index
    - setting draper index..... 265
  - draper speed..... 263
    - setting draper speed ..... 263
    - setting independent of ground speed ..... 266
    - setting minimum draper speed ..... 264
  - header float
    - float options with deck shift ..... 269
  - header position ..... 260
  - hydraulics configuration - D-Series ..... 259
  - knife speed
    - setting knife speed “on the go” ..... 268
  - reel fore-aft position..... 260
  - reel height..... 260
  - reel speed..... 260
    - reel index ..... 260
    - reel minimum speed..... 260
    - reel only speed ..... 262
    - reel to ground speed ..... 260
  - setting draper to ground speed..... 263
- decals
  - fuse box decal..... 383
  - GSL header switch functions..... 74
  - location of safety signs ..... 13
- deck shift - D-Series ..... 269
- declaration of conformity ..... i
- DEF
  - definitions ..... 27
- definition of terms ..... 27
- diesel exhaust fluid (DEF) system ..... 168, 330
  - changing vent hose filter ..... 331
  - draining the tank..... 330
  - filling the tank..... 168
  - refilling the tank..... 331
  - supply module filter ..... 334
    - checking..... 334
    - cleaning and inspecting ..... 335
    - installing ..... 336
    - removing ..... 334
- display modules
  - DEF ..... 66
- DM
  - definitions ..... 27
- DOC
  - definitions ..... 27
  - ULSD
    - definitions ..... 27
- double windrow attachment (DWA) ..... 212
  - deck position..... 212
  - draper speed..... 213
- draper index
  - setting for D-Series..... 265
- draper speed

## INDEX

- setting for D-Series ..... 263
- setting independent of ground speed ..... 266
- setting minimum draper speed ..... 264
- drive wheel ..... 400
- drive wheels
  - installing ..... 403
- driving the windrower ..... 169
  - cab-forward operation ..... 171
  - driving on road ..... 179
  - engine-forward operation ..... 173
  - entering/exiting ..... 170
  - reverse in cab-forward mode ..... 172
  - reverse in engine-forward mode ..... 175
  - spin turn ..... 176
  - stopping ..... 176
- E**
- ECU
  - definitions ..... 27
- electrical system ..... 167, 354
  - accessing circuit breakers and fuses ..... 381
  - battery ..... 354
    - adding electrolyte ..... 358
    - battery main disconnect switch ..... 355
    - boosting the battery ..... 358
    - charging the battery ..... 356
    - connecting the battery ..... 361
    - installing the battery ..... 360
    - maintaining the battery ..... 354
    - removing the battery ..... 359
  - checking and replacing fuses ..... 381
  - fuse box decal ..... 383
  - inspecting 125A main fuse ..... 385
  - preventing damage to electrical system ..... 354
  - replacing 125A main fuse ..... 385
  - replacing circuit breaker/relay ..... 382
- engine ..... 309
  - air intake system ..... 314
  - belt ..... 345
  - charge air cooling ..... 321
  - engine cooling system ..... 337
  - engine error codes on CDM display ..... 154
  - engine gearbox maintenance ..... 342
    - adding lubricant ..... 342
    - changing lubricant ..... 343
    - checking lubricant level ..... 342
  - general engine inspection ..... 309
  - manually turning the engine ..... 309
  - manuals ..... 309
  - warning lights ..... 167
- engine compartment hoods, *See* hoods
- engine cooling system ..... 337
  - cooler box ..... 349
  - cleaning screens and coolers ..... 349
  - closing screen ..... 353
  - maintaining ..... 350
  - opening screen ..... 349
  - screen cleaner duct to screen
    - clearance ..... 353
- engine coolant
  - adding coolant ..... 341
  - changing coolant ..... 339
  - checking coolant level ..... 337
  - checking coolant strength ..... 338
  - draining coolant ..... 339
- pressurized coolant tank cap
  - inspecting pressurized coolant tank cap ..... 338
- engine error codes ..... 459
- engine operation
  - adjusting the throttle ..... 348
  - diesel exhaust fluid (DEF) ..... 168
  - engine speed ..... 348
  - engine temperature ..... 167
  - fuelling ..... 327
  - intermediate speed control (ISC) ..... 166
  - oil pressure ..... 167
  - shutting down the engine ..... 166
  - starting the engine ..... 163
    - cold start ..... 165
    - engine warm-up ..... 165
    - normal start ..... 164
- engine warning lights ..... 89
- engines
  - cleaning filter element ..... 319
  - engine controls and display module ..... 65
  - inspecting exhaust system ..... 344
- error codes
  - CDM/WCM
    - miscellaneous ..... 493
- evaporator core ..... 304
  - cleaning ..... 305
- F**
- filters
  - air filter
    - changing secondary air filter ..... 319
    - installing primary air filter ..... 317
    - removing primary air filter ..... 315
  - changing vent hose filter ..... 331
  - charge oil filter ..... 392
    - installing ..... 392
    - removing ..... 392
  - engine filter
    - cleaning filter element ..... 319
  - fuel filter ..... 322
    - installing primary fuel filter ..... 323

## INDEX

- installing secondary fuel filter ..... 325
- removing primary fuel filter ..... 322
- removing secondary fuel filter ..... 324
- HVAC filter
  - cleaning return air cleaner/filter ..... 304
  - installing fresh air filter ..... 302
  - removing fresh air filter ..... 301
  - removing/installing return air filter/cleaner ..... 303
- hydraulic oil filters ..... 391
- return oil filter ..... 393
  - installing ..... 393
  - removing ..... 393
- final drives ..... 192
- floats, *See* header float
- fuel and diesel exhaust fluid (DEF) display modules ..... 66
  - alarm ..... 70
  - tools menu ..... 68
- fuel system ..... 321
  - fuel filter ..... 322
    - installing primary fuel filter ..... 323
    - installing secondary fuel filter ..... 325
    - removing primary fuel filter ..... 322
    - removing secondary fuel filter ..... 324
- fuel specifications ..... 443
- fuel tank
  - draining the fuel tank ..... 325
  - fuel/water separator ..... 328
  - removing water-in-fuel sytem ..... 328
  - removing/installing fuel tank vent filter ..... 321
- fuel, fluids, and lubricants ..... 443
- priming ..... 329
- fuse box decals ..... 383
- fuses
  - accessing ..... 381
  - checking and replacing ..... 381
  - inspecting and replacing 125A ..... 385
- G**
- gearboxes
  - engine gearbox maintenance ..... 342
- glossary ..... 27
- gps automated steering systems ..... 419
- GSL, *See* header controls
- H**
- header angles ..... 204
- header controls ..... 73
  - console header switches ..... 77
    - deck shift/float preset switch ..... 77
    - DWA/swath roller switch (if installed) ..... 78
- display selector switch ..... 75
- ground speed lever (GSL) header switches ..... 74
- header drive reverse button ..... 73
- header drive switch ..... 73
- header position switches ..... 76
- reel and disc speed switches ..... 76
- reel position switches ..... 75
- header drive ..... 203
- header float ..... 196
  - adjusting float using drawbolts ..... 198
  - checking float ..... 196
  - float operating guidelines ..... 196
  - float options and presets ..... 199
  - float options with deck shift (D-Series) ..... 269
- header levelling ..... 200
- header operation ..... 194
  - engaging the header ..... 203
  - header and reel hydraulics ..... 394
  - header angle ..... 204
  - header drive ..... 203
  - header drop rate ..... 211
  - header float ..... 196
  - levelling the header ..... 200
  - operating with a header
    - A-Series header ..... 272
    - D-Series header ..... 259
    - R-Series header ..... 280
  - reversing the header ..... 204
- headers
  - A-Series headers
    - attaching
      - non-self-aligning hydraulic center-link ..... 235
      - self-aligning hydraulic center-link ..... 230
    - detaching
      - hydraulic center-link ..... 241
  - D-Series headers
    - attaching
      - header boots ..... 214
      - non-self-aligning hydraulic center-link ..... 220
      - self-aligning hydraulic center-link ..... 215
    - detaching
      - hydraulic center-link ..... 226
  - definitions ..... 27
  - drop rate ..... 395
  - R-Series headers
    - attaching
      - non-self-aligning hydraulic center-link ..... 250
      - self-aligning hydraulic center-link ..... 244
    - detaching
      - hydraulic center-link ..... 255
- heater shut-off valves ..... 56

## INDEX

- heating, See HVAC system
  - hoods
    - closing from highest position ..... 286
    - closing from lower position ..... 285
    - opening to highest position ..... 285
    - opening to lowest position ..... 284
  - horns ..... 64
  - HVAC system
    - A/C compressor ..... 307
      - coolant cycling ..... 162
      - servicing the compressor ..... 308
    - A/C condenser ..... 304
    - A/C cover
      - installing cover ..... 306
      - removing cover ..... 305
    - A/C evaporator
      - cleaning evaporator core ..... 305
    - A/C evaporator core ..... 304
    - air distribution ..... 56
    - components
      - compressor belt
        - replacing ..... 347
        - tensioning ..... 347
    - controls ..... 57
    - fresh air filter element cleaning ..... 301
    - fresh air intake filter ..... 301
      - installing filter ..... 302
      - removing filter ..... 301
    - heater shut-off valve ..... 56
    - return air cleaner/filter ..... 303
      - cleaning ..... 304
      - removing/installing ..... 303
  - hydraulics
    - changing hydraulic oil filters ..... 391
    - charge oil filter ..... 392
    - checking and filling hydraulic oil ..... 389
    - D-Series header hydraulics ..... 259
    - draining hydraulic oil ..... 390
    - filter
      - installing charge oil filter ..... 392
      - installing return oil filter ..... 393
      - part numbers ..... 445
      - removing charge oil filter ..... 392
      - removing return oil filter ..... 393
  - fittings
    - flare-type ..... 451
    - O-ring boss (ORB) adjustable ..... 453
    - O-ring boss (ORB) non-adjustable ..... 455
    - O-ring face seal (ORFS) ..... 456
  - header and reel hydraulics ..... 394
    - flow control blocks ..... 395
    - header drop rate ..... 395
    - pressure compensator valve ..... 394
  - hydraulic hoses and lines ..... 399
  - hydraulic oil cooler ..... 390
  - hydraulic safety ..... 6
  - reel drop rate
    - adjusting ..... 396
  - return oil filter ..... 393
  - traction drive hydraulics ..... 397
    - charge pump pressure ..... 398
    - transmission oil pressure ..... 397
  - warnings ..... 388
- ## K
- knife speed
    - A-Series header ..... 278
    - setting “on the go” for A-Series header ..... 279
    - setting “on the go” for D-Series header ..... 268
- ## L
- lighting ..... 49
    - auto road ..... 53
    - beacons ..... 53
      - replacing bulb ..... 375
    - cab-forward mode
      - field ..... 49
      - road ..... 51
    - engine-forward mode
      - field ..... 50
    - field lights
      - adjusting field lights ..... 366
      - replacing bulb ..... 367
    - flood lights
      - adjusting cab-forward flood lights ..... 367
      - adjusting rear flood lights ..... 372
      - replacing bulb in cab-forward flood light ..... 367
      - replacing bulb in rear flood light ..... 373
    - headlights
      - aligning headlights ..... 362
      - replacing bulb ..... 364
    - HID auxiliary lighting ..... 369, 419
      - adjusting HID lights ..... 372
      - replacing lamp ..... 369
    - interior lights ..... 58
      - ambient light ..... 380
      - dome light ..... 379
    - red and amber lights
      - replacing bulbs ..... 374
    - red tail lights (if installed)
      - replacing bulb ..... 375
    - turn signal indicators ..... 381
  - lubricating windrowers ..... 292
    - lubricants/fluids/system capacities ..... 444
    - lubricating engine gearbox ..... 342
    - lubricating wheel drive

## INDEX

- adding lubricant ..... 404
  - changing wheel drive lubricant ..... 405
  - lubricating wheel drives
    - checking lubricant levels ..... 404
  - lubrication points ..... 293
  - lubrication procedure ..... 292
  - recommended fuel, fluids, and lubricants ..... 443
  - storing lubricants and fluids ..... 443
- M**
- maintenance
    - A/C compressor belt
      - replacing ..... 347
      - tensioning ..... 347
    - battery ..... 354
    - drive wheel ..... 400
    - electrical system ..... 354
    - engine ..... 309
      - air intake system ..... 314
      - charge air cooling ..... 321
      - engine oil
        - checking ..... 311
      - general engine inspection ..... 309
      - manually turning the engine ..... 309
    - engine belt ..... 345
    - engine compartment
      - opening and closing platforms ..... 287
    - engine cooling system ..... 337
    - engine exhaust system ..... 344
    - engine gearbox ..... 342
    - filter part numbers ..... 445
    - fuel system ..... 321
      - priming the fuel system ..... 329
    - fuel, fluids, and lubricants ..... 443
    - HVAC system ..... 301
      - fresh air filter element cleaning ..... 301
    - lighting
      - aligning headlights ..... 362
    - lubricating the windrower ..... 292
    - maintenance schedule ..... 414
    - operator presence system ..... 294
    - operator's station ..... 294
      - engine interlock ..... 295
    - preparing for servicing ..... 283
    - safety systems ..... 294
    - system priming ..... 329
    - wheel and tire ..... 400
  - maintenance and servicing ..... 5
    - maintenance safety ..... 5
  - maintenance platforms ..... 287
  - maintenance schedule ..... 414
  - metric bolts
    - torque specifications ..... 448
- minimum reel speed ..... 260
- N**
- neutral
    - adjustment troubleshooting ..... 488
- O**
- oils (engine)
    - adding ..... 313
    - checking level ..... 311
    - draining ..... 312
    - replacing engine oil filter ..... 313
  - operations ..... 160
    - See also* engine operation
    - See also* header operation
  - auto raise height feature ..... 210
    - programming auto raise height feature ..... 210
    - using auto raise height ..... 211
  - break-in period ..... 161
  - daily check ..... 162
  - double windrowing ..... 212
    - deck position ..... 212
    - draper speed ..... 213
  - driving the windrower ..... 169
  - operating with a header ..... 194
    - A-Series header ..... 272
    - D-Series header ..... 259
    - R-Series header ..... 280
  - preseason checks/annual service ..... 161
    - distributing A/C compressor coolant ..... 162
  - return to cut feature
    - programming return to cut feature ..... 208
    - using return to cut feature ..... 209
  - swath roller ..... 213
  - operator presence system ..... 41
    - engine and transmission ..... 41
    - header drive ..... 41
  - operator's seat
    - adjusting armrest ..... 43
    - adjusting armrest angle ..... 45
    - adjusting fore-aft position ..... 42
    - adjusting lumbar support ..... 45
    - adjusting seat tilt ..... 44
    - adjusting suspension and seat height ..... 42
    - adjusting vertical dampener ..... 43
    - fore-aft isolator lock ..... 44
  - operator's station ..... 39, 294
    - AM/FM radio ..... 62
    - auto road light ..... 53
    - beacon lighting ..... 53
    - cab-forward lighting - field mode ..... 49
    - cab-forward lighting - road ..... 51



## INDEX

- climate controls ..... 57
- emergency exit ..... 59
- engine controls and DEF display module ..... 65
- engine interlock ..... 295
- engine-forward lighting - road ..... 50
- GSL adjustments ..... 295
  - adjusting GSL fore-aft movement ..... 296
  - adjusting GSL lateral movement ..... 295
- header controls ..... 73
- horn ..... 64
- interior light ..... 58
- lighting ..... 49
- operator amenities ..... 60
- operator console ..... 39
- operator presence system ..... 41, 294
  - engine and transmission ..... 41
  - header drive ..... 41
- rear view mirror ..... 55
- safety systems ..... 294
- seat belts ..... 47, 294
- steering ..... 297
- steering column ..... 48
- training seat ..... 46
- windrower controls ..... 71
- windshield wiper ..... 54
- options and attachments
  - AM/FM radio ..... 419
  - automated steering ..... 419
  - booster spring kit - external ..... 420
  - booster spring kit - internal ..... 420
  - case drain kit ..... 421
  - double windrow attachment (DWA) ..... 420
  - engine block heater ..... 424
  - fan air baffle ..... 424
  - header drive reverser ..... 421
  - HID auxiliary lighting ..... 419
  - light header flotation ..... 420
  - lighting/marketing for cab-forward travel ..... 423
  - pressure sensor kit ..... 421
  - rotary header drive hydraulics (13-foot) ..... 421
  - self-aligning center-link ..... 421
  - swath roller ..... 213, 421
  - towing harness ..... 423
  - transport drawbar ..... 423
  - valve for driving rotary disc header (B4657) ..... 422
  - weight box ..... 185, 423
  - windshield shades ..... 419
- owner/operator responsibilities ..... 155
  
- P**
- platforms ..... 287
  - closing platform (major service) ..... 290
  - closing platform (standard position) ..... 288
  - opening platform (major service) ..... 289
  - opening platform (standard position) ..... 287
- pressurized coolant tank
  - inspecting pressurized coolant tank cap ..... 338
- priming
  - fuel system ..... 329
- programming
  - auto raise height feature ..... 210
  - cab display module (CDM) ..... 93
  - return to cut-feature ..... 208
  
- R**
- R-Series headers
  - attaching ..... 244
  - kit for 13-foot R85 ..... 280
  - setting disc speed ..... 280–281
- radios ..... 62
- rear view mirrors ..... 55
- reel height
  - D-Series header ..... 260
- reel index ..... 260
- reel minimum speed ..... 260
- reel speed
  - A40-D header ..... 274
  - D-Series header ..... 260
- reel-to-ground speed ..... 260
- references
  - definition of terms ..... 27
- relays
  - replacing ..... 382
- return to cut feature ..... 207
  - programming return to cut ..... 208
  - using return to cut ..... 209
- revisions ..... v
- rpm
  - definitions ..... 27
  
- S**
- SAE
  - bolt torques ..... 446
  - definitions ..... 27
- safety
  - alert symbols ..... 1
  - battery safety ..... 8
  - engine safety ..... 10
    - engine electronics ..... 11
    - high pressure rails ..... 10
  - general safety ..... 3
  - header safety props ..... 194
  - hydraulic safety ..... 6
  - maintenance and servicing ..... 5

## INDEX

operational safety .....	160
safety sign decals .....	12
installing decals .....	12
interpreting decals .....	17
sign location .....	13
signal words .....	2
tire safety .....	7
screen cleaners	
adjusting clearance .....	353
seat belts .....	47
maintaining seat belts .....	294
serial numbers	
location .....	vii
shutting down the engine .....	166
specifications .....	30
filter part numbers .....	445
fuel .....	443
torque specifications .....	446
windrower dimensions .....	34
spm	
definitions .....	27
starting the engine .....	163
cold start .....	165
engine warm-up .....	165
normal start .....	164
steering .....	297
adjusting steering chain tension .....	299
adjusting steering column .....	48
checking steering link pivots .....	297
storing windrowers .....	192
swath rollers .....	213
symbols	
definition .....	156
diesel exhaust fluid (DEF) functions .....	157
engine function .....	156
header function .....	159
windrower operating .....	158

## T

T4	
checking and replacing of fuses and relays .....	385
electronic control unit (ECU) power fuse .....	384
fuses and relays .....	384
temperature	
cab .....	56
engine .....	167
torque specifications .....	446
flare-type hydraulic fittings .....	451
metric bolt specifications .....	448
bolting into cast aluminum .....	451
O-ring boss (ORB) fittings (non-adjustable) .....	455

O-ring boss (ORB) hydraulic fittings (adjustable) .....	453
O-ring face seal (ORFS) fittings .....	456
SAE bolt torque specifications .....	446
towing	
attaching tow-bar to windrower .....	185
towing header with windrower .....	182
towing the windrower (emergency) .....	191
tractors	
definitions .....	27
training seats .....	46
transporting	
attaching header transport hitch to header .....	185
converting from field to transport mode .....	182
converting from transport to field mode .....	189
troubleshooting	
cab air .....	437
electrical .....	430
engine .....	425
header drive .....	432
hydraulics .....	431
operator's station .....	441
steering and ground speed control .....	436
traction drive .....	433
trucks	
definitions .....	27

## V

ventilating, See HVAC system

## W

weight boxes	
attaching to windrower .....	185
wheels and tires .....	400
adjusting caster tread width .....	177
caster wheel .....	177
anti-shimmy dampener .....	412
ballast requirement .....	413
inflating caster tire .....	406
installing forked caster wheel .....	410
installing formed caster wheel .....	411
lowering formed/forked caster wheel .....	409
raising forked/formed caster wheel .....	408
removing forked caster wheel .....	410
removing formed caster wheel .....	411
tightening nuts .....	407
drive wheel	
drive wheel nut torque procedure .....	401
inflating drive tire .....	400
lowering .....	403
raising .....	401
removing .....	402

## INDEX

safety .....	7	changing lubricant.....	405
wheel drive		checking lubricant levels.....	404
adding lubricant .....	404	windshield wipers .....	54





**MacDon Industries Ltd.**

680 Moray Street  
Winnipeg, Manitoba  
Canada R3J 3S3  
t. (204) 885-5590  
f. (204) 832-7749

**MacDon, Inc.**

10708 N. Pomona Avenue  
Kansas City, Missouri  
United States 64153-1924  
t. (816) 891-7313  
f. (816) 891-7323

**MacDon Australia Pty. Ltd.**

A.C.N. 079 393 721  
P.O. Box 243, Suite 3, 143 Main Street  
Greensborough, Victoria, Australia 3088  
t. 03 9432 9982  
f. 03 9432 9972

**LLC MacDon Russia Ltd.**

123317 Moscow, Russia  
10 Presnenskaya nab, Block C  
Floor 5, Office No. 534, Regus Business Centre  
t. +7 495 775 6971  
f. +7 495 967 7600

CUSTOMERS

**MacDon.com**

DEALERS

**Portal.MacDon.com**

Trademarks of products are the marks of their  
respective manufacturers and/or distributors.

Printed in Canada