

# QUICK REFERENCE CARD FOR GLEANER COMBINES

## Combine Preparations (R60/62/70/72)

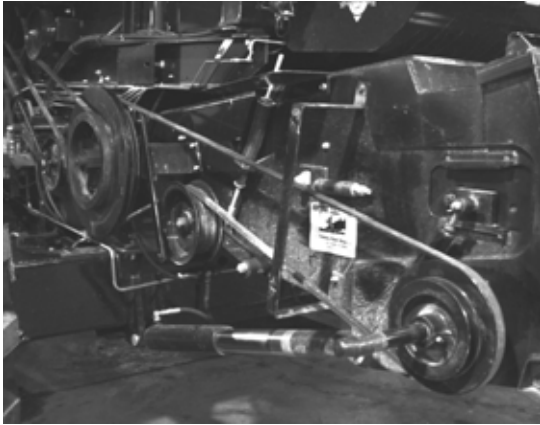

- ❑ Adjust R/H pivot shaft drive for grain. Position belt on small drive sheave (top) and large drive sheave (bottom).

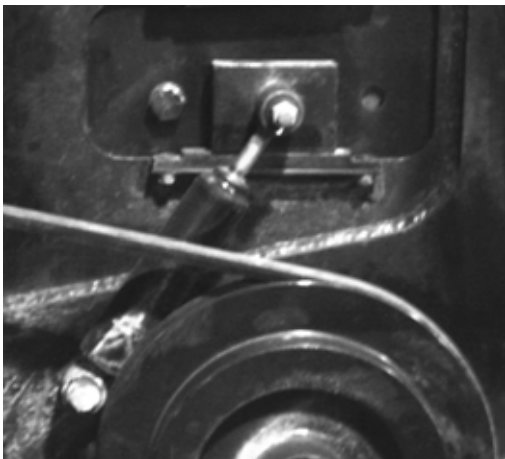

- ❑ Adjust feed conveyor drum height to small grains position as per combine operators manual.
- ❑ Pre 1997 combines, tilt feeder house face plate  $\frac{3}{4}$  of the way back towards the cab. For 1998 and newer the faceplate is rigid and cannot be tilted.
- ❑ For models with variable speed feeder house drive, set header output shaft speed to 620 rpm.

## 872 Combine Adapter

- ❑ Retracting tine drum on adapter is shipped with dimension X = 4  $\frac{3}{4}$ " (120mm). For best performance, move drum back once shipping braces are removed so dimension X = 3.9" (100 mm). A clearance of 1" to 2" (25 to 50 mm) is required between the feeder chain bars and the adapter drum, with combine feed drum floated up. Rotate adapter drum rearward if required to achieve this dimension.

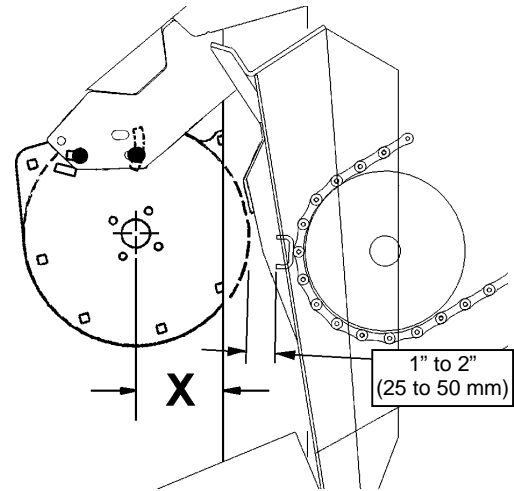

- ❑ Set the mechanical center link between the header and adapter to have 1" (2.5cm) of thread showing from each end.

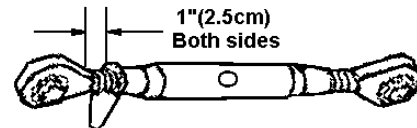

- ❑ Set the float to 70 – 100lbs at each crop divider. Use hook scale if necessary.
- ❑ The bolts that are used to lock out the float for shipping should now be used to fasten the adapter to the header. Pins with spring clips from the hardware package should be used to lock out the float (**during transport**).
- ❑ Set the flow control to number "4".



# QUICK REFERENCE CARD FOR GLEANER COMBINES

REFER TO OPERATORS MANUAL FOR DETAILS ON THE FOLLOWING:

## 962 Harvest Header

- ❑ Set the center delivery opening for all Gleaner combines to **33.9"** (860 mm).

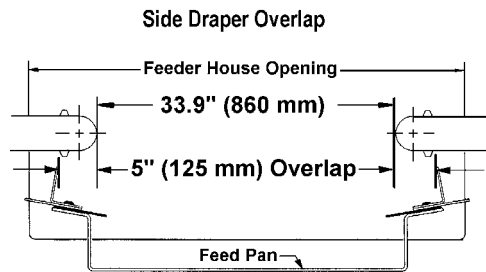

- ❑ The left deck is moveable to allow end delivery swathing. Position the left deck so there is 5" (125 mm) overlap of adapter side deflector.
- ❑ Align the **rear** of the rear deflectors on the feed pan to the edge of the feeder house opening.
- ❑ Leave the draper seals in storage position. (Bolted on the back of right hand panel on 962).



- ❑ For crop stubble 8" (210mm) or less, set gauge wheels/transport to low pressure (field position "2").

## 2000B Pick Up Reel

- ❑ Set the cam arm in the "X" position.
- ❑ Install the bolt going through the cam arm from the inside out (head inboard).



- ❑ Set the reel pitch in **L** or **M** and use range slot **P**. This adjustment is satisfactory for most

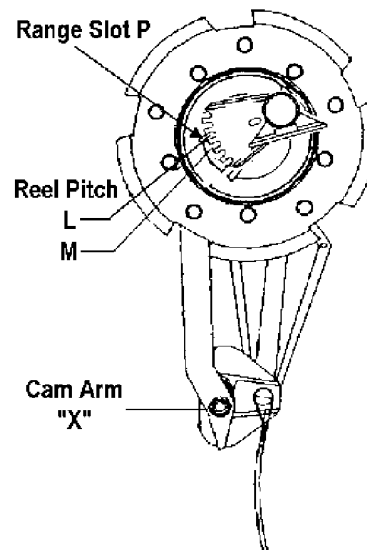

crop conditions.

**NOTE:** Refer to the back side of this card or the Op Manual for further finger pitch adjustments.

- ❑ Set fore/aft position for the pick-up reel in the 5<sup>th</sup> hole, (bat reel 8<sup>th</sup> hole) from the front (crop end) of the reel arm.
- ❑ Set the clearance from the reel fingers to the cutterbar to a minimum of 2" (5cm) for a 30' header, and 1-1/2" (4cm) for 36' headers.
- ❑ Recommended reel speed is 10% above ground speed.

# QUICK REFERENCE CARD FOR GLEANER COMBINES

## 972 Harvest Header

- ❑ Set the center delivery opening for all Gleaner combines to **37.4" (950 mm)**.

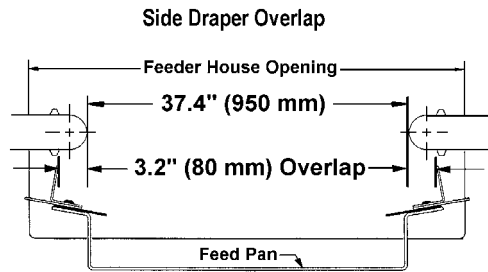

- ❑ Both the 972,1052 decks are moveable to allow end delivery swathing. Position the decks so there is 3.2" (80 mm) overlap of adapter side deflectors per side.
- ❑ Align the **rear** of the rear deflectors on the feed pan to the edge of the feeder house opening to ensure smooth crop flow.

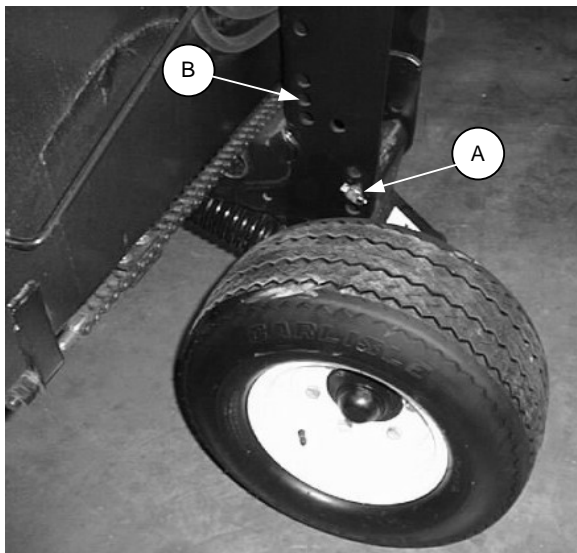

- ❑ Set gauge wheels/transport to "Middle" stubble height. For standard gauge wheels, use hole (A). For transport gauge wheels, use hole (B).

## 2100 6 Bat Pickup Reel

- ❑ Install the bolt going through the cam arm with head **inboard** and torque to 120 ft. lbs. (162 N·m.)

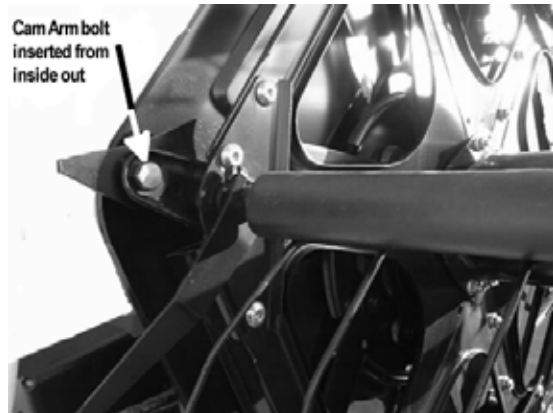

- ❑ Adjust the finger pitch to position "5".

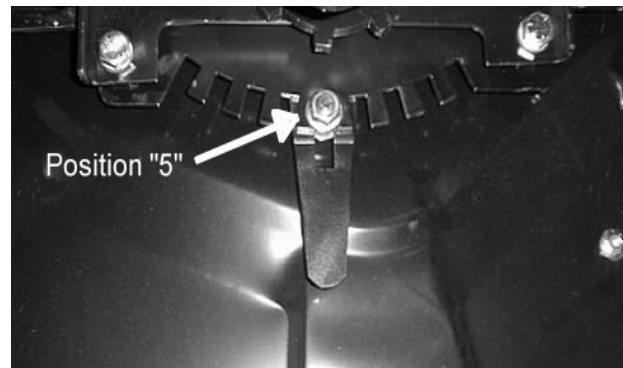

- ❑ Set the fore/aft adjustment in the 9<sup>th</sup> hole from the front (crop end) of the reel arms.
- ❑ Reel finger to sickle guard minimum clearance with reel fully lowered is 5/8" (15mm), **measured at both ends of the cutter bar.**
- ❑ Recommended reel speed is 10% above ground speed.

## Bat Reel

- ❑ Refer to the Op Manual

# QUICK REFERENCE CARD FOR GLEANER COMBINES

962/872 Initial Set-up, for Average Cereal Crops	Field Peas		Edible Beans	
	Average Cereal Crops	Dry Conditions	Wet Condition	Dry Conditions
<b>Sickle</b> -Check daily that guards are aligned. Clearance from hold down to sickle 0.020" (0.05mm).	-	-	Stub guard kit is recommended.	Stub guard kit is recommended.
<b>2000B Reel Fore/ Aft</b> -5 <sup>th</sup> hole/frt. <b>Cam Arm</b> -X <b>Range Slot</b> - P <b>Finger Pitch</b> - L or M <b>Reel Clearance</b> - 2" (50mm) <b>Speed</b> - +10% of ground speed	2 <sup>nd</sup> from front Y Q M 2" (50mm) -	2 <sup>nd</sup> from front Y P J 2" (50mm) -	2 <sup>nd</sup> from front X P M 2" (50mm) -	2 <sup>nd</sup> from front X P M 2" (50mm) -
<b>Draper Speed</b> - Dial position "4". <b>Draper opening</b> - 33.9" (860mm)	- -	- -	- -	- -
<b>Guard Angle</b> - 1.0" (25.4mm) of threads showing on center link. <b>Poly Skids</b> - None	- Yes	- Yes	Center link fully extended. Yes	Center link fully extended. Yes
<b>Gauge Wheels (if equipped)</b> - Most cereals require "position 2" stubble height setting	-	-	-	-
<b>Float</b> - Adjust float in the range of 70 - 100 lbs. at cutter bar end.	150 – 200 lbs.	70 – 100 lbs.	150 –200 lbs.	70 – 100 lbs.

972/872 Initial Set-up, for Average Cereal Crops	Field Peas		Edible Beans	
	Average Cereal Crops	Dry Conditions	Wet Conditions	Dry Conditions
<b>Sickle</b> --Check daily that guards are aligned. Clearance from hold down to sickle .020" (.05mm)	-	-	Stub Guard Kit is recommended.	Stub Guard Kit is recommended.
<b>2100 reel Fore/Aft</b> - 9 <sup>th</sup> hole/front <b>Finger Pitch Adjustment</b> - Slot 5 <b>Reel Clearance</b> - 5/8" (15mm) <b>Speed</b> - +10 % ground speed.	8 <sup>th</sup> from front - - -	7 <sup>th</sup> from front - - -	7 <sup>th</sup> from front Slot 7 ½" (13mm) -	7 <sup>th</sup> from front Slot 7 ½" (13mm) -
<b>Draper Speed</b> - Dial position "4". <b>Draper opening</b> - 37.4" (950mm)	- -	- -	- -	- -
<b>Guard Angle</b> - 1.0" (25mm) of threads showing on center link. <b>Polly Skids</b> - None	- Yes	- Yes	Center link fully extended. Yes	Center link fully extended. Yes
<b>Gauge Wheels (if equipped)</b> - Most cereals require "medium" stubble height setting	Short	Short	Short	Short
<b>Float</b> - Adjust float in the range of 70 – 100 lbs. at cutter bar end.	90 – 120lbs.	70 – 100 lbs.	150 – 200 lbs.	70 – 100 lbs.