

Recommended Header Settings for Direct Cutting

Subject to change without notice

FD75 FlexDraper with CA25 Adapter Quick Card

Crop Type	Stubble Height	Crop Condition	OPERATING VARIABLES										
			Divider Rods	Draper Speed	Header Angle (Note 1)	Knife Speed (Note 2)	Reel Time Pitch	Reel Speed (Note 3)	Reel Position	Skid Shoe Position (Note 4)	Stabilizer Wheel (Note 4)	Upper Cross Auger	
Cereals	Ground	Light	Off	8	Middle (B)	600 - 650	3	10% - 15%	6 or 7	1 or 2	Storage	Not Required	
		Normal	On	7		550 - 600	2	10%				Recommended	
		Heavy	Off	7		525 - 600	3 or 4	5% - 10%				Not Required	
	4 - 8 in.	Light	Off	8	Middle (B)	600 - 650	4	10% - 15%	6 or 7	2 or 3	Variable	Not Required	
		Normal	On	7	Shallow (A)	550 - 600	2	10%				Recommended	
		Heavy	Off	7	Steep (D)	525 - 600	3 or 4	5% - 10%				Not Required	
	10+ in.	Light	Off	8	Shallow (A)	600 - 650	4	10% - 15%	6 or 7	Not Applicable	Variable	Not Required	
		Normal	On	7	Middle (B)	550 - 600	2	10%				Recommended	
		Heavy	Off	7	Steep (D)	525 - 600	3 or 4	5% - 10%				Not Required	
	Canola	4 - 8 in.	Light	On	7	Shallow (A)	600 - 650	2	5% - 10%	6 or 7	3	Variable	Recommended
			Normal			Middle (B)	550 - 600	1	10%				
			Heavy			Middle (B)	550 - 600	1	10%				
Lodged			Steep (D)			525 - 600	2	5% - 10%					
10+ in.		Light	On	7	Shallow (A)	600 - 650	2	5% - 10%	6 or 7	Not Applicable	Variable	Recommended	
		Normal			Middle (B)	550 - 600	1 or 2	10%					
		Heavy			Middle (B)	550 - 600	1 or 2	10%					
		Lodged			Steep (D)	525 - 600	2 or 3	5% - 10%					
California Rice		Ground	Light	Whisker (Note 5)	4	Steep (D)	600 - 650	2	10% - 15%	6 or 7	1 or 2	Storage	Not Required
			Normal			Middle (B)	550 - 600		10%				
			Heavy			Middle (B)	550 - 600		10%				
		4 - 8 in.	Light	Whisker (Note 5)	4	Steep (D)	600 - 650	3	10% - 15%	6 or 7	2 or 3	Variable	Not Required
	Normal		Middle (B)			550 - 600	10%						
	Heavy		Middle (B)			550 - 600	10%						
	10+ in.	Light	Whisker (Note 5)	4	Shallow (A)	600 - 650	3	10% - 15%	6 or 7	Not Applicable	Variable	Not Required	
		Normal			Middle (B)	550 - 600		10%					
		Heavy			Middle (B)	550 - 600		10%					
	Delta Rice	2 - 6 in.	Light	Off	6	Steep (D)	600 - 650	2 or 3	10% - 15%	6 or 7	2 or 3	Variable	Not Required
			Normal			Middle (B)	550 - 600		10%				
			Heavy			Middle (B)	550 - 600		10%				
8 + in.		Light	Off	6	Shallow (A)	600 - 650	2 or 3	10% - 15%	6 or 7	Not Applicable	Variable	Not Required	
		Normal			Middle (B)	550 - 600		10%					
		Heavy			Middle (B)	550 - 600		10%					
Soybeans	Ground	Light	On	8	Steep (D)	600 - 650	2	5% - 10%	6 or 7	1 or 2	Storage	Not Required	
		Normal			Middle (B)	550 - 600		10%					
		Heavy			Middle (B)	550 - 600		10%					
		Lodged			Steep (D)	525 - 600		3 or 4					5% - 10%
Flax	2 - 6 in.	Light	On	8	Middle (B)	600 - 650	2	5% - 10%	6 or 7	2 or 3	Variable	Not Required	
		Normal			Shallow (A)			10%					
		Heavy			Middle (B)			10%					
		Lodged			Steep (D)			5% - 10%					
Peas	Ground	Light	On	7	Middle (B)	600 - 650	2	5% - 10%	6 or 7	1 or 2	Storage	Recommended	
		Normal			550 - 600	10%							
		Heavy			550 - 600	10%							
		Lodged			Steep (D)	525 - 600		4 or 5					5% - 10%
Lentils	Ground	Light	On	8	Middle (B)	600 - 650	2	5% - 10%	6 or 7	1 or 2	Storage	Not Required	
		Normal				550 - 600		10%					
		Heavy				550 - 600		10%					
		Lodged				Steep (D)		525 - 600					3 or 4

Notes:

- Keep guard angle as shallow as possible. Center link position depends on skid shoe and stabilizer wheel position. Set guard angle and skid shoe position to maximize amount of poly on the ground while maintaining desired cutting height.
- Minimum knife drive pulley RPM. Applicable to only single knife drive headers.
- Percentage above ground speed.
- Cutting height is controlled with a combination of skid shoes, stabilizer wheels and header angle. By supporting header with skid shoes or stabilizer wheels, the adapter floats header over obstacles and ground contours.
- Available through your Dealer Parts Department. Set divider rods to highest or second to highest position in standing crop. This position allows the dividers to level the down crop for a cleaner cut at the ends of the header. Whisker divider not required on both ends of header.

STEP 1: PRE-ADJUSTMENTS Complete before adjusting Float or Wing Balance.

- Park combine and header on a level surface. Ensure that the combine feederhouse is level.
- Place wing lock spring handles in the locked position.
- Set guard angle to mid-position (between B and C on the indicator).
- Set the reel fore-aft to mid-position (5 or 6 on reel arm indicator).
- Lower reel completely.
- If equipped, set stabilizer/transport wheels to the fully raised position.
- Raise header so cutterbar is 6-10 inches (150-250 mm) above ground.
- Place header float locks in unlocked (lowered) position.

STEP 2: SET HEADER FLOAT

- Remove the special torque wrench (A) from storage position on RH side of the CA25 combine adapter.
- Place torque wrench (A) on the float lock at (B).
- Push down on torque wrench (A) until bell crank (C) rotates forward.
- Continue pushing down until indicator (D) on wrench reaches a MAXIMUM reading and begins to decrease. Note the maximum reading.
- Refer to TABLE 1 for recommended initial float setting:
 - If reading on wrench is high, header is heavy, and float needs to be increased.
 - If reading on wrench is low, header is light, and float needs to be decreased.
- Adjust header float to match values in TABLE 1. Turn each bolt pair equal amounts.
 - To **increase float** (lighten header), tighten (clockwise) float spring bolts (E) and (F).
 - To **decrease float** (increase header weight), loosen (counter clockwise) float spring bolts (E) and (F).
 - Ensure wrench reading is equal on both sides.

NOTE

For 40 and 45 FT Double Knife Headers, adjust float as above, and then **loosen RIGHT SIDE FLOAT** spring bolts (F) **2 turns**.

THESE ARE THE 4 STEPS TO SET HEADER FLOAT AND WING BALANCE

IMPORTANT

Be sure to have read your Operator's Manual, and complete all set-up tasks before setting Header Float and Wing Balance.

TABLE 1

Header Width	Torque Settings	
	Cutting on the Ground	Cutting off the Ground
30 and 35 FT	1-1/2 to 2	2 to 2-1/2
40 and 45 FT	2 to 2-1/2	2-1/2 to 3

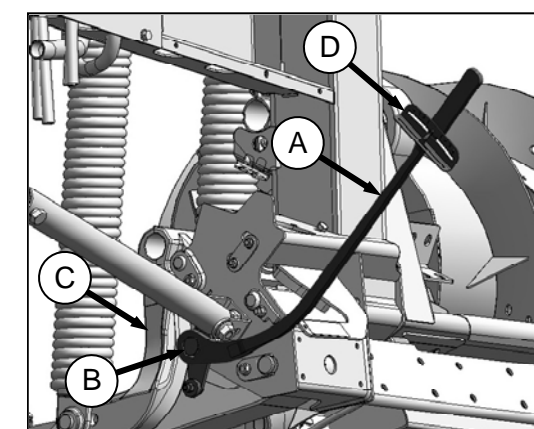

LEFT SIDE

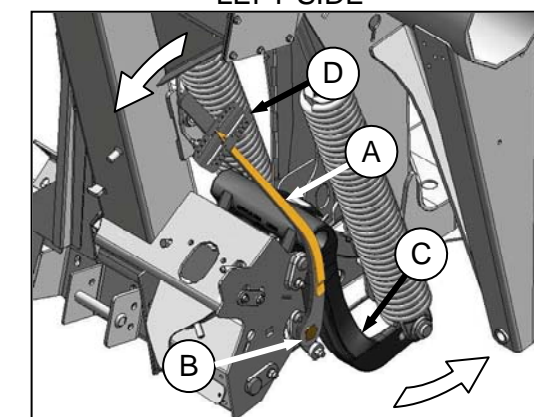

RIGHT SIDE

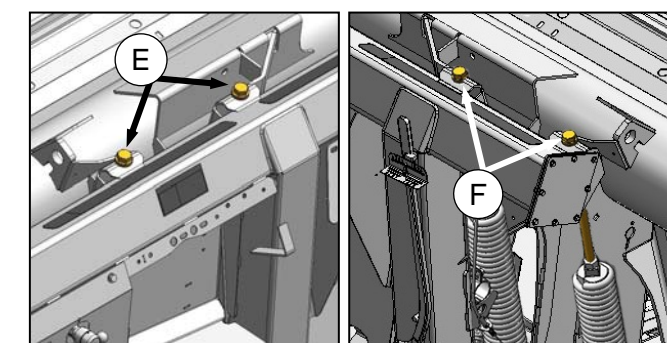

LEFT SIDE FLOAT

RIGHT SIDE FLOAT

FD75 FlexDraper with CA25 Adapter Quick Card

STEP 3: CHECK WING BALANCE

1. Remove poly linkage covers.
 2. Place torque wrench (A) on bolt (G).
 3. Move spring handle (H) to lower position so that lock link drops into lower slot.
- NOTE**
- If lock link does not engage lower slot, move with torque wrench (A) until lock link moves into slot.*
4. Move wing **upward** with torque wrench (A) until pointer lower alignment tab (J) lines up with upper edge of top link (K). Note indicator reading (L) on wrench.
 5. Move wing **downward** with torque wrench (A) until pointer upper alignment tab (M) lines up with the lower edge of the top link (K). Note indicator reading (L) on the wrench.
 6. If the difference between the readings is **1 or less**, the wing is **balanced** and no further adjustment is required.
 7. If the difference between the readings is **more than 1**, the wing is **imbalanced**. Record the readings and proceed to STEP 4.

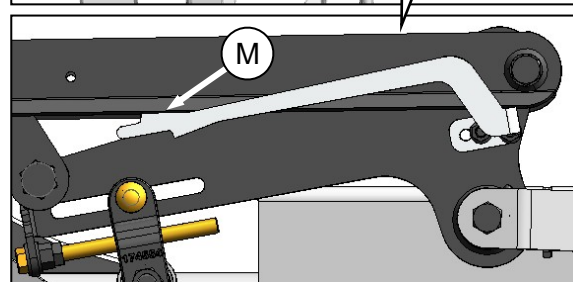
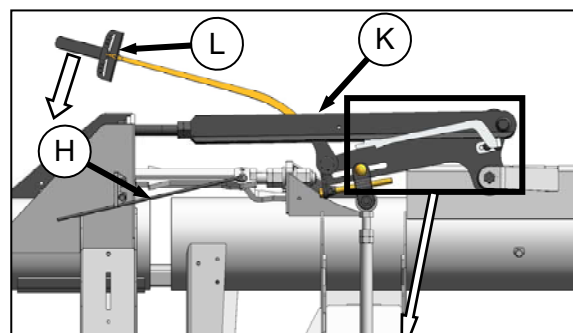
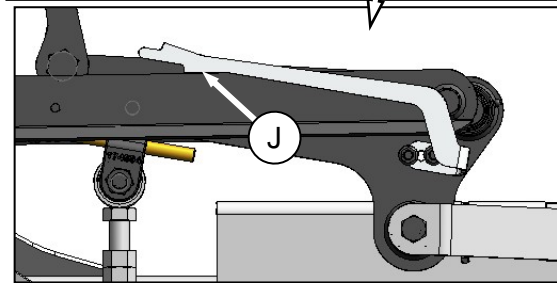
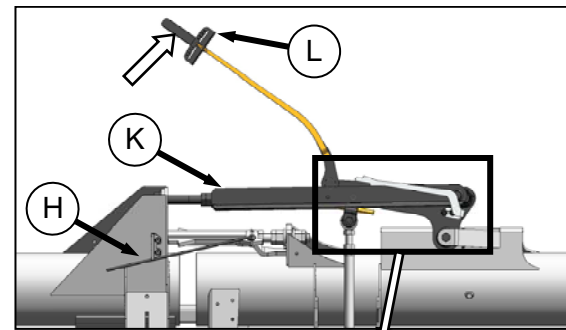
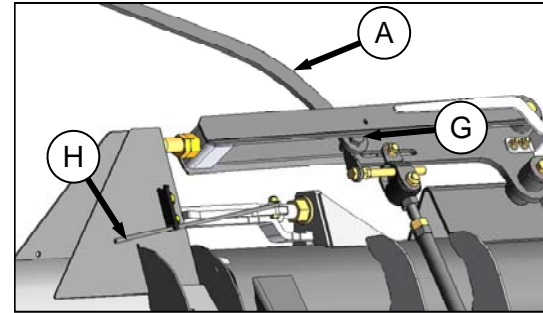

STEP 4: ADJUST WING BALANCE

1. Use the readings taken in STEP 3, and the images on this page to determine if the wing is too heavy or too light.
2. Loosen the clevis bolt for the wing requiring adjustment.
3. Balance the wing according to the Wing Balance Adjustment Detail image below.
4. Tighten the clevis bolt.
5. Repeat STEPS 3 and 4 (if necessary) for the opposite wing.
6. Re-install poly linkage covers.

