

MacDon®

**FC Series
FlexCorn™ Header**

Operator's Manual

262141 Revision A

Translation of Original Instruction

The Harvesting Specialists.

INTRODUCTION

INTRODUCTION

Dear Customer,

The following is some useful information provided to help ensure efficient and safe operation of this corn head.

This manual gives some information regarding the MacDon FC Series FlexCorn Headers.

Read this manual carefully to learn how to operate and service your machine correctly. Failure to do so could result in personal injury or equipment damage.

This manual should be considered a permanent part of your machine and should remain with the machine when you sell it.

Since the corn head can be mounted to many models of combines, carefully read your combine specifications and follow the combine manufacturer's recommendations for usage, set-up and operation of the combine.

TABLE OF CONTENTS

TABLE OF CONTENTS

1. SAFETY	5
2. SAFETY DECALS.....	7
2.1 RECOGNIZE SAFETY INFORMATION.....	7
2.2 SAFETY LABEL MEANINGS	8
3. OPERATION AND FUNCTION.....	17
4. IDENTIFICATION AND SPECIFICATIONS.....	21
4.1. IDENTIFICATION	21
4.2. SPECIFICATIONS	22
5. MOUNTING THE CORN HEAD ON THE COMBINE	23
5.1. MOUNTING THE CORN HEAD ON THE COMBINE.....	23
5.1.1 John Deere S series	23
5.1.2. CIH Flagship; NH CR & CX.....	24
5.1.3. Claas Lexion 700, 7000, & 8000 series	24
5.2. CONNECT HEADER DRIVE SHAFTS	25
6. FLEXCORN HEADER SETUP	26
6.1 WIRING INSTALLATION	26
7. HYDRAULIC SYSTEM SETUP.....	29
8 HEADER START-UP PROCEDURE	43
9. SETUP PROCEDURE AND ADJUSTMENT OF THE CORN HEAD.....	44
9.1. PARKING STANDS	44
9.2. AUGER.....	45
9.3. Auger Timing:	46
9.4. GEARBOX DRIVE.....	47
9.5. SNAPPING UNITS.....	48
9.5.1. Snapping rolls adjustment.....	48
9.5.2. Snapping plate adjustment	49
9.5.3. Vine knife adjustment.....	51
9.5.4. Snapping Roll Rebuild	51
9.5.5. Gathering chain adjustment	52
9.6. HEADER DRIVE SHAFTS	54
9.6.1 Conventional Driveline Service	54
9.6.2 CV Driveshaft Service.....	55
9.7 ADJUSTMENT OF THE CORN HEAD.....	56
9.7.1 Header angle adjustment	56
9.7.2. Plastic snout adjustment	56
9.8 END SHOE STALK DEFLECTOR LINK.....	58
9.9 INSTALLING LOCK LINK.....	61
9.10 REMOVING LOCK LINK	62
9.11 TRANSITION SEAL ADJUSTMENT	63
10. HARVESTING.....	65

TABLE OF CONTENTS

10.1.	STALK CHOPPER	66
10.2	SNAPPING PLATE POSITION.....	66
10.3	CONTROL SYSTEM/OPERATOR.....	66
11.	MOUNTING TO ANOTHER TYPE OF COMBINE	72
12.	MAINTENANCE AND LUBRICATION.....	73
12.1.	AUGER.....	73
12.2.	DRIVE GEARBOXES	73
12.4.	DRIVE COMPONENTS	74
12.4.1.	U-joint shafts:	74
12.4.2.	Chain couplings, Slip clutches.....	74
12.5.	SNAPPING UNIT.....	75
12.5.1.	Gearboxes	75
12.5.2	Chopper knives	77
12.5.3.	Snapping roll.....	78
12.5.4.	Gathering chain.....	79
12.5.5.	Snapping plate cable	79
12.6	LOWER LINKS.....	80
12.7	ACCUMULATOR CHARGE PRESSURE (CHECK ANNUALLY)	81
13.	ELECTRICAL SCHEMATICS	82
13.1.	POWER & GROUND	82
13.2.	SENSORS 1	83
13.3.	SENSORS 2.....	84
13.4.	CONTROL - HYDRAULICS.....	85
13.5.	LIGHTING	86
13.6.	NETWORKS.....	87
13.7.	CONNECTORS 1	88
13.8.	CONNECTORS 2	89
13.2.	ELECTRICAL SCHEMATIC FOR THE ADAPTER	94
14.	TROUBLE SHOOTING	95
14.1.	A LARGE QUANTITY OF EARS BUILDS UP BETWEEN THE AUGER AND FEEDER.....	95
14.2.	IN LAID OR LODGED CORN STALKS, THE STALKS DO NOT FEED PROPERLY INTO THE SNAPPING ROLLS. 95	
14.3.	ROW UNIT BECOMES PLUGGED WHILE HARVESTING LAID OR LODGED CORNSTALKS.	95
14.4.	STALKS, GRASS OR WEEDS WRAP ON THE SNAPPING ROLL.	95
14.5.	AUGER DOES NOT ROTATE.	95
14.6.	EARS ARE BROKEN OR SPLIT IN THE AUGER.....	96
13.7.	CHECKS TO RESOLVE FEEDING ISSUES IN DRY CROP	96
14.8	FLEX SYSTEM.....	97
14.9	SPECIFIC ISSUE TROUBLESHOOTING.....	99
15.	OFF-SEASON STORAGE OF YOUR CORN HEAD	101
16.	WARRANTY, SERVICE, SPARE PARTS ORDERING	101
17.	LUBRICATION CHART.....	102
18.	PRE-HARVESTING INSTRUCTIONS	104
18.1	PRE-HARVESTING CHECK LIST	104
18.2	PRE-HARVESTING INSTRUCTIONS.....	105

TABLE OF CONTENTS

18.2.1	Flex Position Sensor adjustment procedure	105
18.2.2	Skid shoe sensor adjustment procedure.	105
18.2.3	Proximity sensor troubleshooting.	105
19.	TORQUE VALUES	107
19.1	TORQUE VALUES FOR FASTENERS	107
19.2	TORQUE VALUES FOR HYDRAULIC FITTINGS.....	108
19.2.1	L Series	108
19.2.2	S Series	108
20	APPENDIX:.....	109
20.1	HYDRAULIC SCHEMATIC	109

1. **SAFETY**



This is the safety-alert symbol. When you see this symbol on your machine or in this manual carefully read the message that follows, and be alert to the possibility of personal injury or death.

Follow recommended precautions and safe operating procedures.

UNDERSTAND SIGNAL WORDS

A signal word – DANGER, WARNING, or CAUTION – is used with the safety-alert symbol. DANGER identifies the most serious hazards.

DANGER or WARNING safety decals are located near specific hazards. General precautions are listed on CAUTION safety decals. CAUTION also calls attention to safety messages in this manual.

FOLLOW SAFETY INSTRUCTIONS

Carefully read all safety messages in this manual and on your machine safety decals. Keep safety decals in good condition. Replace missing or damaged safety decals. Be sure new components and repair parts include current safety decals.

GENERAL SAFETY GUIDELINES

1. **ALLOW ONLY TRAINED AND EXPERIENCED OPERATORS TO OPERATE THIS MACHINE.** Operating this equipment safely requires the full attention of the operator. Do not wear entertainment headphones while operating this machine.
2. **ALWAYS DISENGAGE** header drive, shut off the engine and remove key before service, adjustment, maintenance and lubrication of the corn head.
3. **STAY CLEAR** of the header when it is in operation.
4. **DO NOT OPEN** safety shields or covers while the corn head is running.
5. **ENGAGE** the lock on the feeder lift cylinder before doing any work under or around the corn head.
6. **WORN OR DAMAGED CHOPPER KNIVES** must be replaced before operation of the corn head. Radial clearance between knife and bushing must be properly maintained. See details in this manual.
7. **NEVER** remove the warning labels from the machine. If they become damaged or illegible order replacement parts as shown in the Figures.
8. **NEVER** remove the safety hydraulic valve of the folding corn heads, located on the back of the corn head.
9. Accumulators store oil at high pressure even when power is removed. **ALWAYS** follow the service mode procedure when servicing any hydraulic component.

2. SAFETY DECALS

2.1 Recognize safety information

Carefully read Operator's Manual before operating the machine. When operating, always observe safety instructions.

WARNING!

This is the safety – alert symbol.



When you see this symbol on your machine or in this manual, be alert to the potential for personal injury. Carefully read all safety messages in this manual and on your machine safety signs, and respect them fully to avoid accidents leading to serious injury or death!

WARNING!

Keep safety signs in good condition. Replace missing or damaged safety signs. Replacement safety signs are available from the manufacturer. It is **PROHIBITED** to remove safety signs from your machine!



WARNING!

Before installing the machine read the operator's manual carefully, learn how to operate, control and keep your machine in good condition. Do not let anyone operate it without instruction.



1.326.700

Keep your machine in proper working condition. Unauthorized and non-professional modifications to the machine may impair the function and safety and affect the machine life.

2.2 Safety label meanings

The function of the labels is to give, easy to understand safety instructions for those who are staying close to the machine, in order to minimize the risk of accidents. It is therefore important that these labels always be easy to read, and in complete condition.

- a. Before beginning any maintenance or lubricating, stop the engine of the combine and remove the key!



1.326.703

- b. If you stop the combine while the header is lifted, engage the combine feederhouse safety stops to prevent header movement.



1.326.701

- c. Always stay clear of moving elements during operation! Always disengage header drive, shut off the engine and remove key before servicing or unclogging header.



1.315.438

- d. Always keep your distance from the rotating parts of the machine. The header's snapping rolls and other moving parts can't be covered completely due to their functions. Do not feed crop material into machine by hand or attempt to manually unplug machine while it is running. The stalk rolls can feed the crop material in faster than you can release your grip on it. To avoid personal injury or mortal accident always stop engine before unclogging.



1.326.702

SAFETY

e. Never attempt to open or remove shield while the engine is running. Keep every shield in its place. Avoid direct contact of your hand, leg, any part of your body or clothes with rotating, moving machine parts, elements! Before approaching any moving parts wait for them to completely stop!

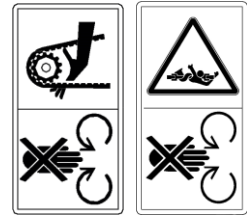

1.326.705 1.379.142

f. Header can lower unexpectedly. Shut off machine, remove key, and engage feederhouse locks before going underneath header.



1.315.439

g. If the engine is still operating, the combine can accidentally start. Never step between the header and the combine if the engine is not shut off!



1.379.143

h. Machines equipped with chopper are more dangerous because of objects thrown out unexpectedly. Do not stay close to operating machine. Follow the instructions on use and maintenance of chopper knives!



1.315.440

i. High pressure oil can cause severe injury. Remove power and drain pressure before servicing hydraulic system.

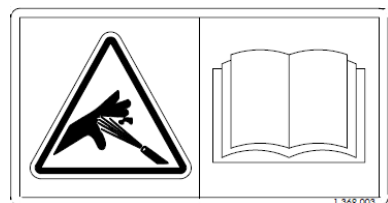

1.369.003

SAFETY

j. Direction of driveshaft rotation.

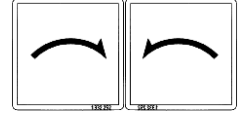

1.332.252-3

k. To prevent injury from sharp cutting blades: Do NOT operate without shields in place. Disengage power take-off, stop engine and remove key before opening covers. Stop engine and remove key before opening shield. Blades may continue to rotate after power is shut off. Listen and look for evidence of rotation before opening shield.



1.372.836

l. To prevent injury from entanglement with rotating auger: Stand clear of auger while machine is running.



1.372.837

m. Lifting points on the lifting bar.

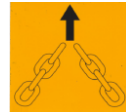

514.038.0

n. Tie-down point locations.



1.372.890

o. Chopper knife covers are marked with safety decals. Do NOT operate without covers in place.



1.373.044

p. QR code label leading to the MacDon Owners resources website.



1.372.822

SAFETY

- q. To avoid injury from pinching or crushing. Keep hands clear while machine is operating.



1.369.004

- r. Escaping fluid or gas from systems with pressurized accumulators can cause serious injury. Extreme heat can cause the accumulator to burst, and pressurized lines can be accidentally cut.



1.369.071

- s. Do not weld or use torch near a pressurized accumulator or pressurized line.
- t. Relieve pressure from the pressurized or hydraulic system before removing accumulator.
- u. Never attempt to relieve hydraulic system or accumulator pressure by loosening a fitting.
- v. Accumulators cannot be repaired.*.

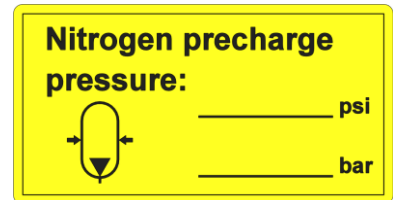

1.3669.091

LIST OF ACTIVE MACHINE PARTS

No.	Active machine part	Danger
1.	Snapping units, gathering chains	Snatch, entanglement
2.	Gathering auger	Cutting, entanglement
3.	Outside shields	Nip, bruise
4.	Side chain drive	Snatch, entanglement
5.	Drive shafts	Entanglement
6.	Inner space between combine and corn head	Crushing
7.	Stalk chopper	Cutting, impact from unexpected flying objects
8.	Shields, snouts	Slipping , stumbling
9.	Lifted machine	Crushing
10.	Hydraulics	High-pressure fluid injection
11.	Flex Linkages	Crushing/Pinching
12.	Skid shoes linkage	Crushing/Pinching
13.	Raised wings	Crushing

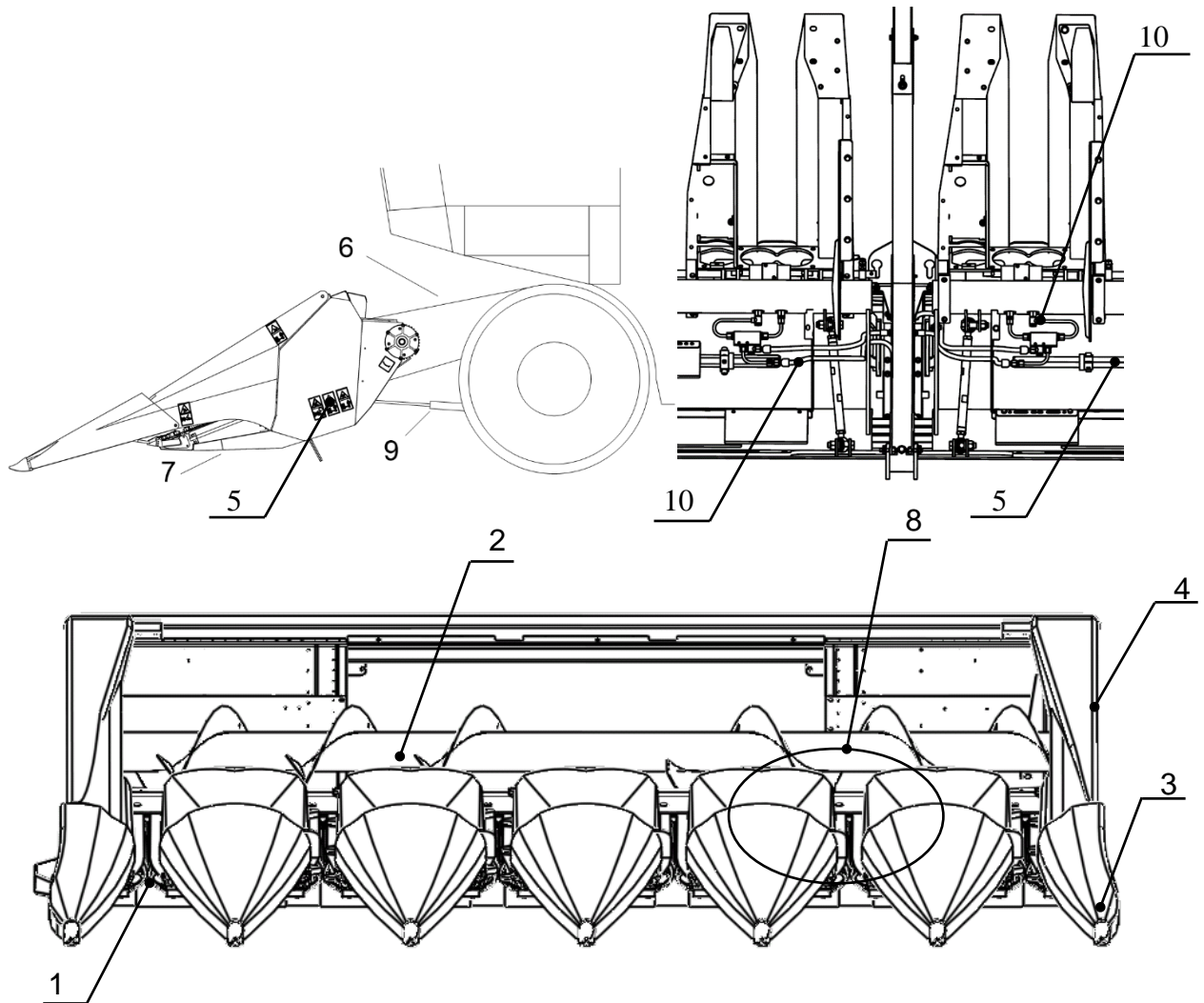

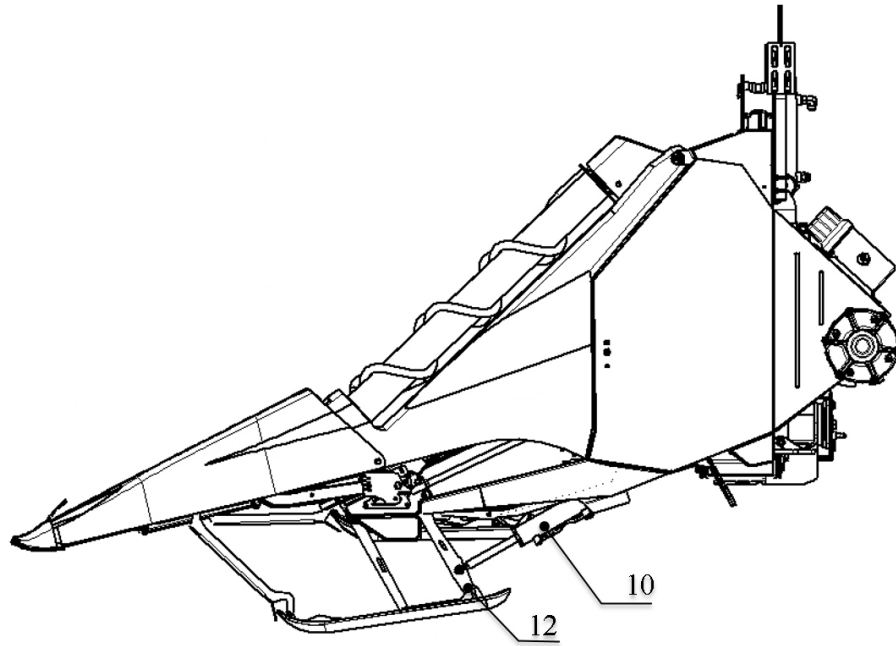
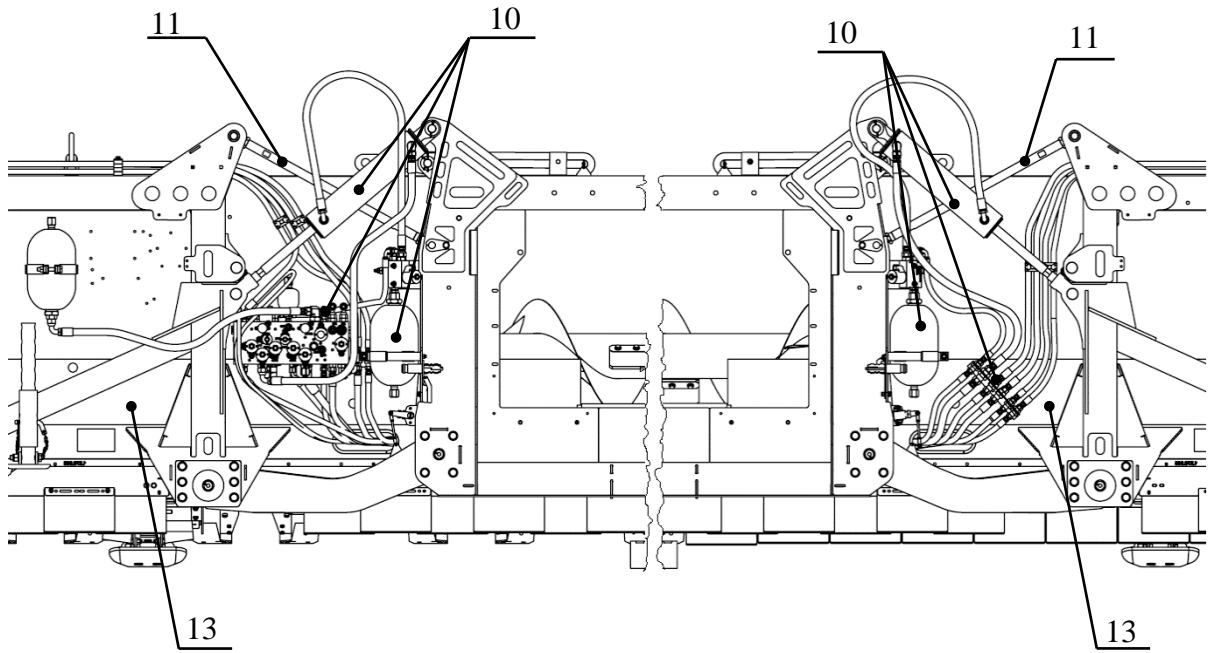

SAFETY

Illustration below shows placement of safety decals.

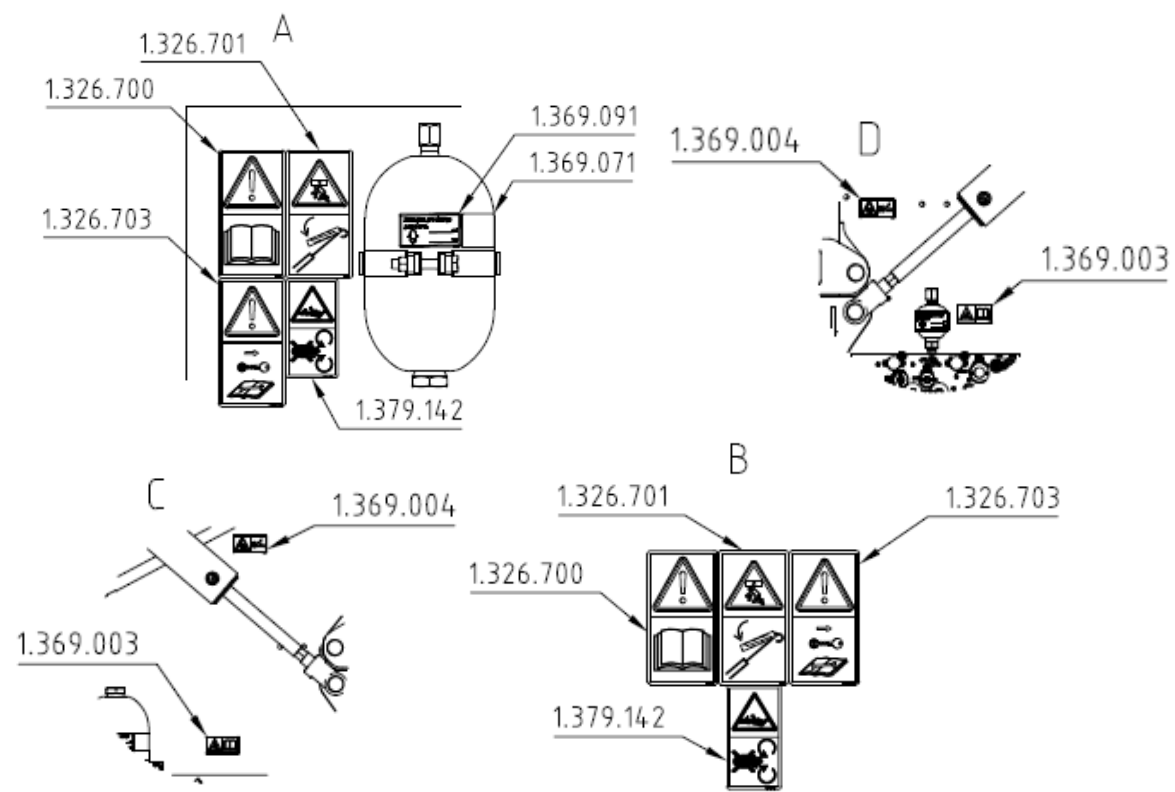
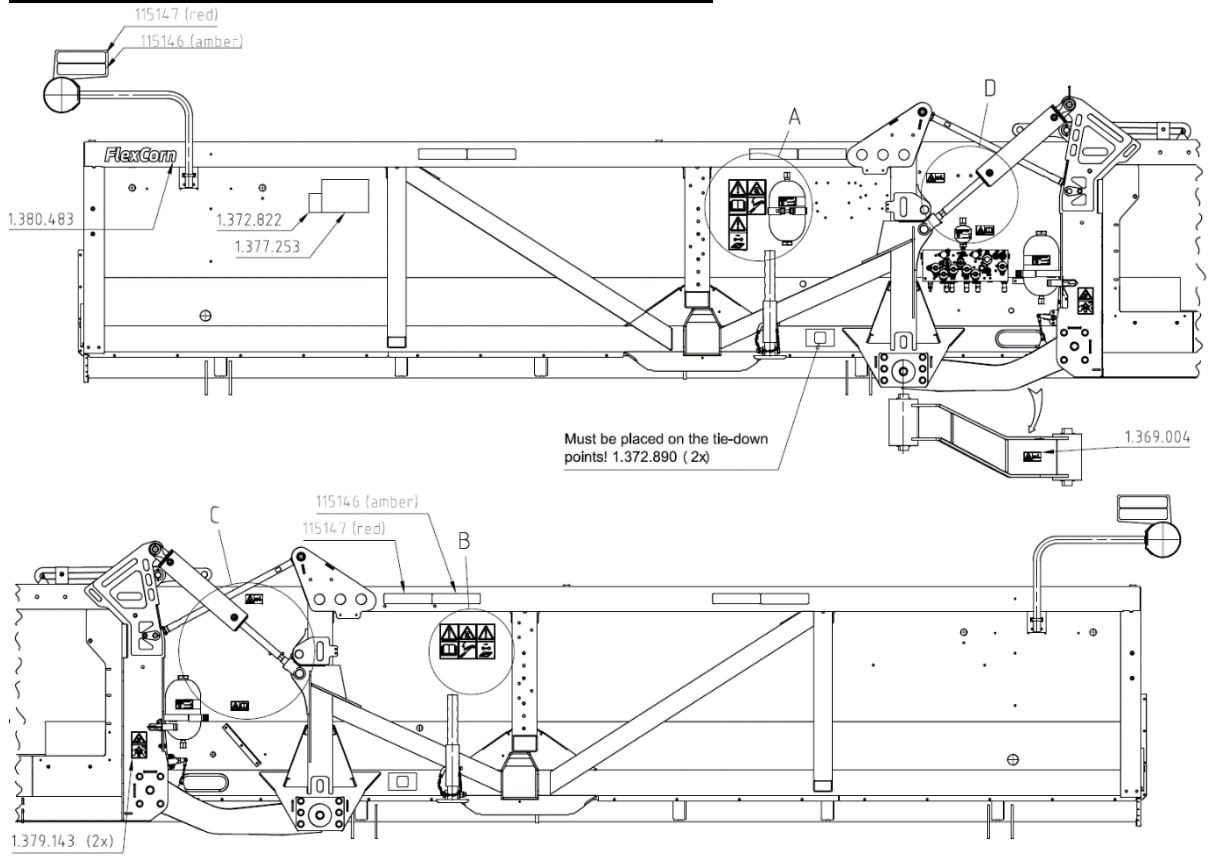

SAFETY

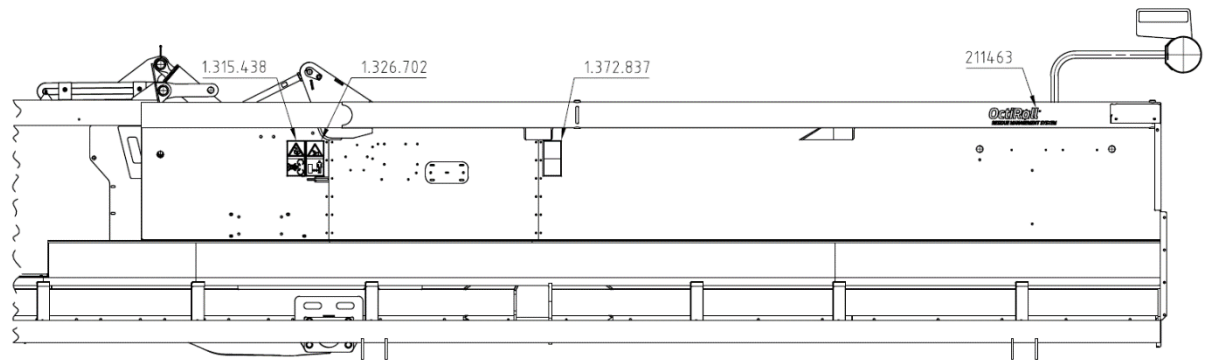
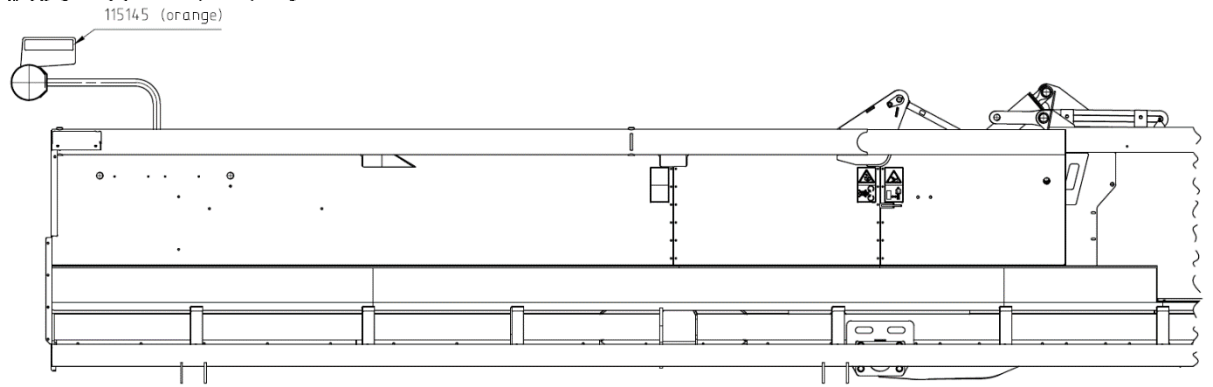
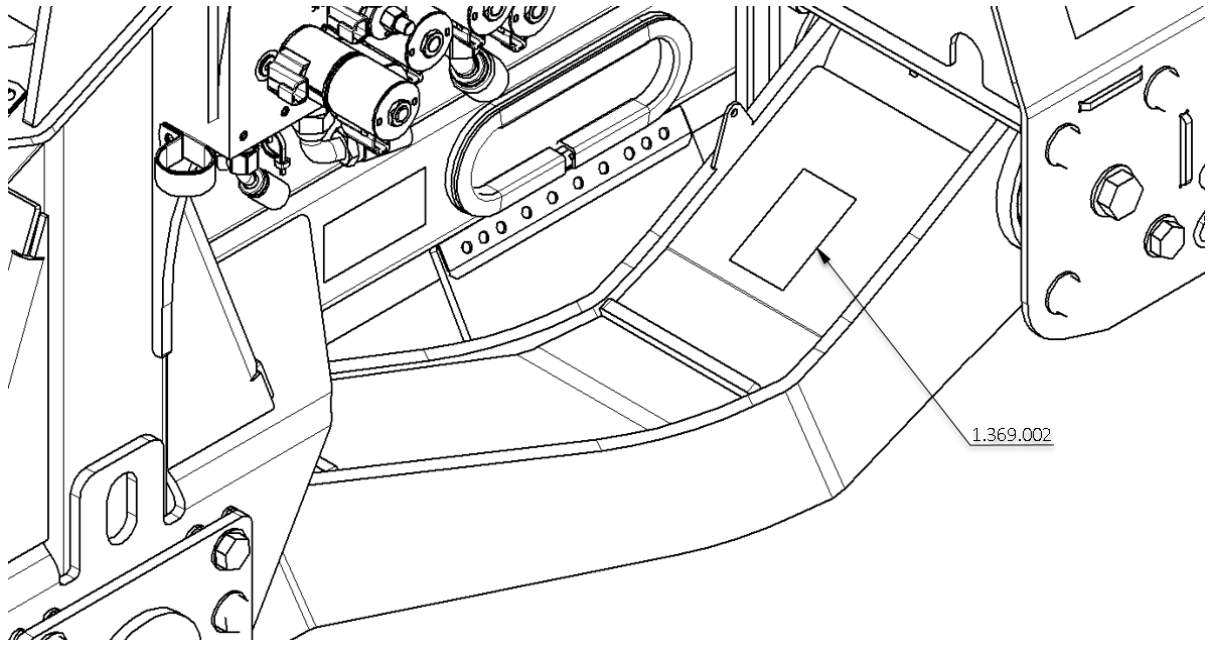

1.332.252
Must be stuck to the inner side of the cover.

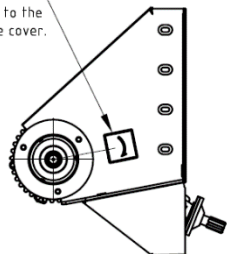

1.332.253
Must be stuck to the inner side of the cover.

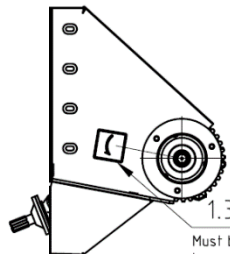

SAFETY

The figure shows the placement of machine safety decals.

Attention! The figure shows only the labels on one side of the header, but in reality the decals must be placed symmetrically on both sides.

Note: On the image the LH side of the header is shown.

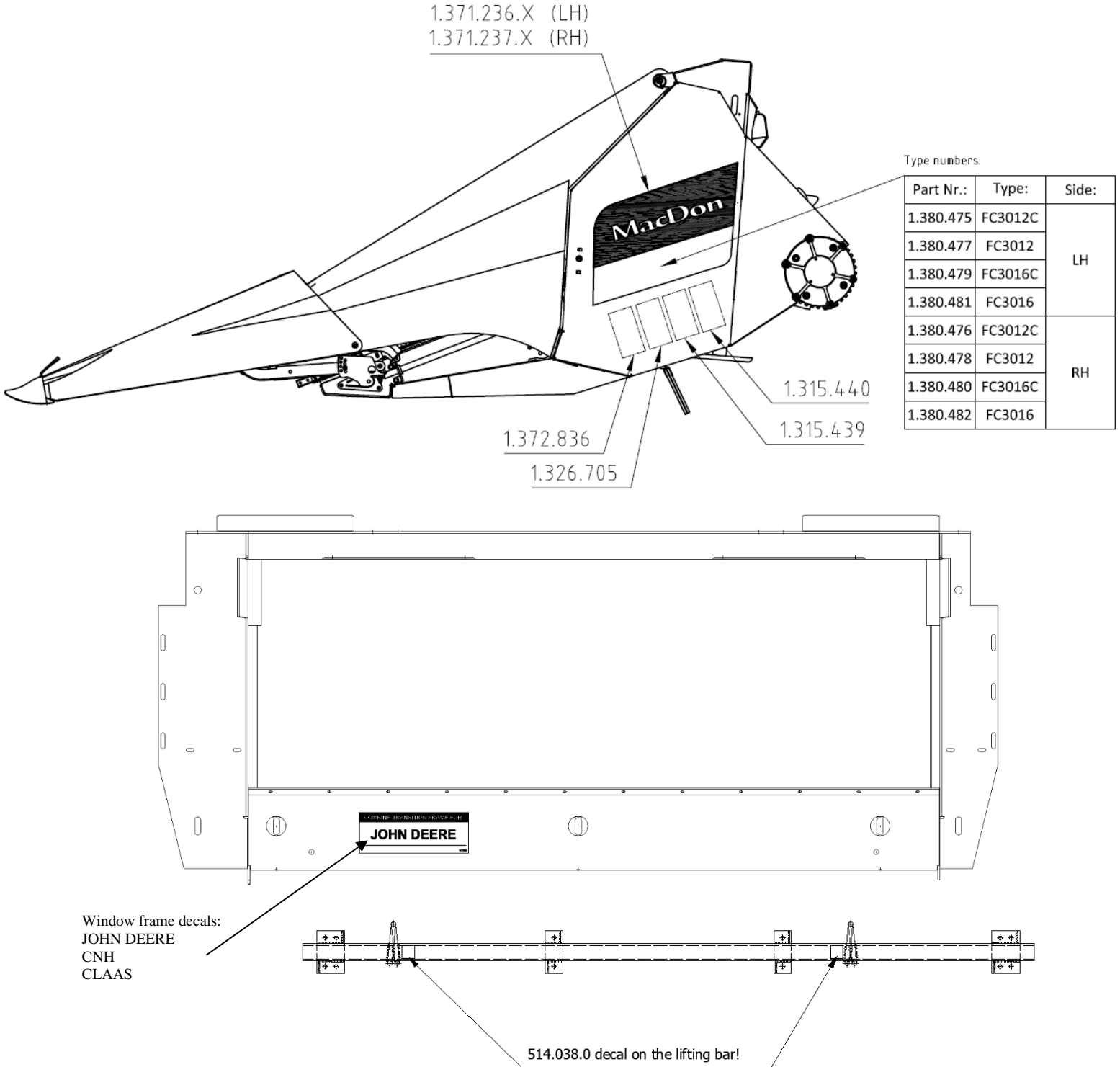

3. OPERATION AND FUNCTION

The MacDon corn head can be mounted on most combines. Corn ears are detached from the corn stalks as is shown on the illustration below. The corn stalk enters the area between the snapping rolls (1,2) which counter-rotate relative to each other, and are pulled downwards between the snapping plates (3) by the rolls (1,2). This downward directing action causes the corn ears (5) to impact the snapping plates (3), detaching the ear from the stalk in the process. The detached ears are moved rearward by the gathering chains (6) into the auger trough (7) and are conveyed to the combine feederhouse by the gathering auger (8). Corn stalks are discharged downward by the snapping rolls (1,2).

If the corn head is equipped with optional stalk choppers, the stalks are chopped into small pieces by this chopper, located under the snapping rolls.

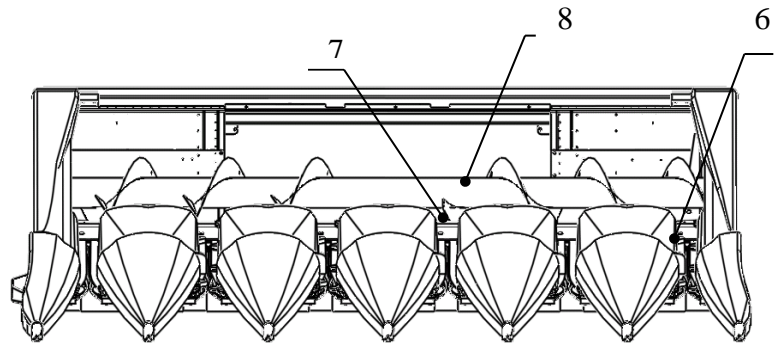
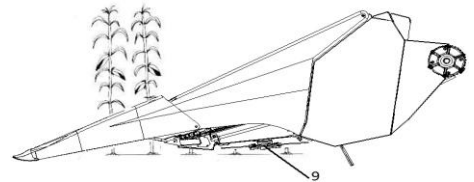
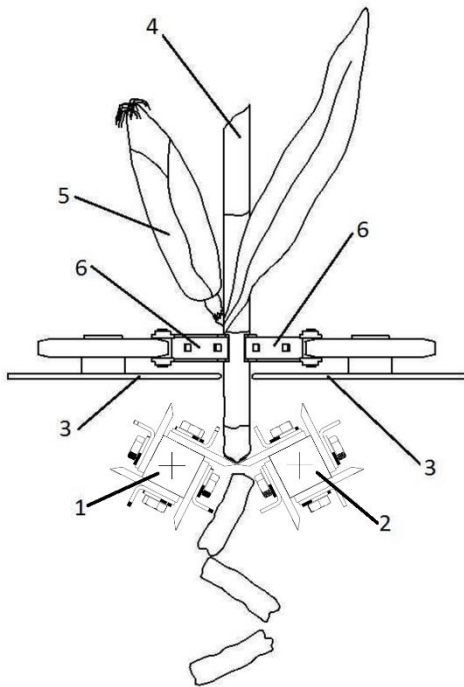

Attention!

For safe corn head operation, it is essential to respect the instructions on the use of the corn head when mounted to the combine. Only qualified operators should operate the machine.

The ground following system

MacDon FlexCorn headers are designed to maximize your harvest in the most challenging terrain. Using two pivoting wings, the FC series headers can flex up to 31” up and 30” down over a 15.1 degree range. Using the reel drive hydraulics, the operator can adjust the pressure in the flex cylinders to support over 98% of the header weight. Height adjustable skid shoes provide constant ground contact to instantly follow ground contours and maintain consistent cut height no matter the terrain.

Control System Overview and Introduction

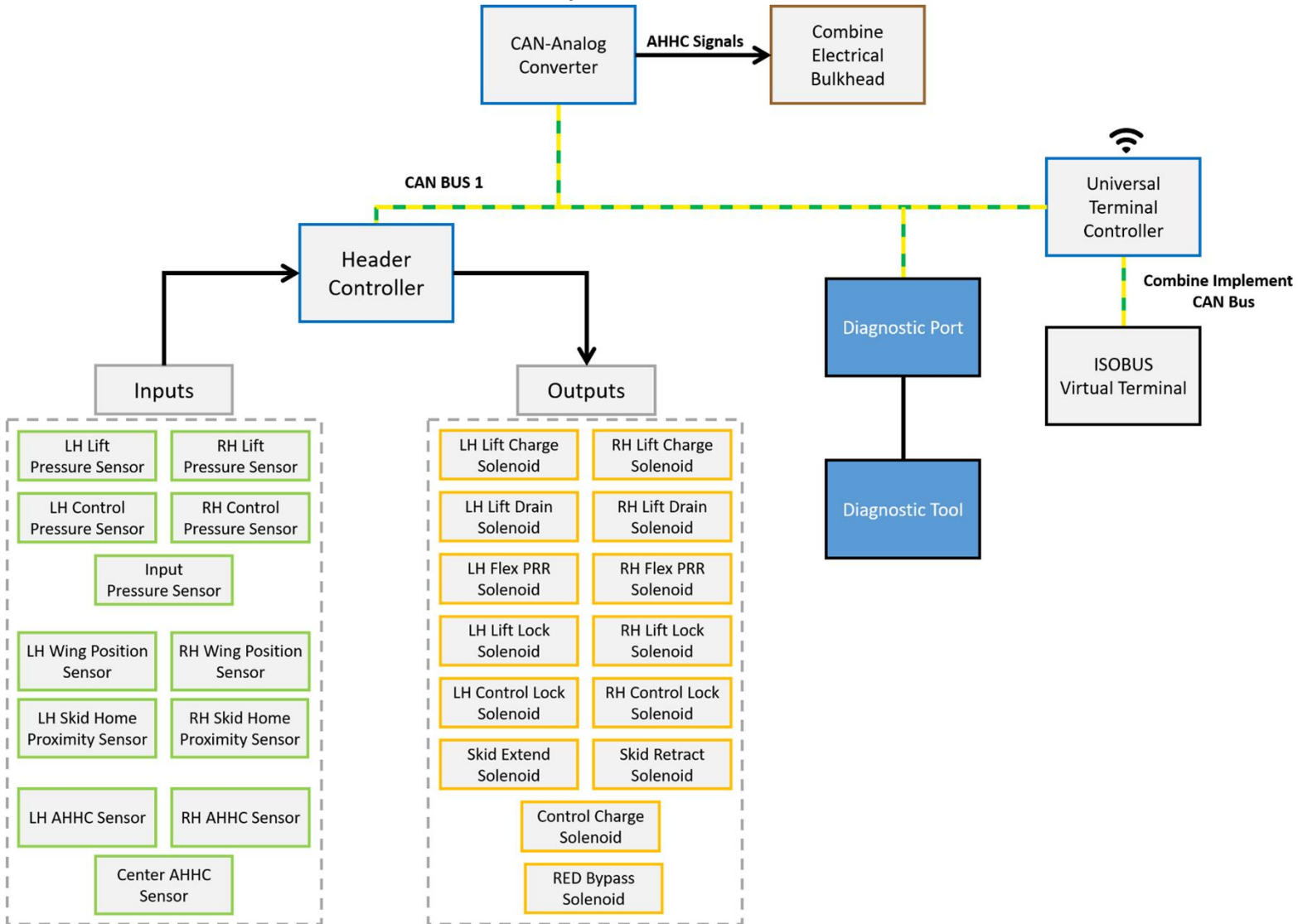

The FlexCorn control system consists primarily of two controllers. The Header Controller is located on the FlexCorn header and controls all the functions of the header. The Universal Terminal (UT) Controller is located in the cab of the combine and provides an operator interface via the combine’s ISOBUS UT. The two controllers communicate via CAN bus to provide operator inputs to the header controller and feedback and diagnostic data to the UT controller. The CAN-Analog Converter is a third controller that outputs analogue voltages to the combine electrical bulkhead for Automatic Header Height Control (AHHC).

Operation

The corn head is driven from the combine feeder shaft through a universal or constant velocity (CV) drive shaft. Power is transmitted from the drive shaft by gears encased in an oil bath to a shaft which passes through the snapping unit.

Torque limiting clutches transmit power from the shaft to each snapping unit.

The gathering auger is driven through two torque limiting clutches from both the left and right side snapping unit drive.

Consider and follow each of the following sequence guidelines before starting operation of the corn head:

- after sounding the horn, start the engine of the combine
- after ensuring that no one is close to the corn head and combine, lower the corn head into operation position using the combine “lower” function switch



1. Operate the corn head only in the specified harvesting position
2. Engage the combine feeder drive and begin harvesting.
3. Operate at a ground speed that does not exceed that suitable for the combine and corn head capacity and ground conditions.
4. Perform an emergency stop

During harvesting be aware of unexpected events that may take place requiring immediate shutdown of the forward movement or combine feeder drive.

Such events could be:

- accident
- foreign materials in the crop (irrigation pipe, gas tube, rocks etc.) which could enter the corn head
- excessive crop loading (action of torque limiting clutches)
- clogging or blockage
- other breakdown or fault

The corn head has no specific emergency stop system. The emergency stop is actuated using the combine systems located in the combine cab. Understand and respect the relevant instructions of the combine emergency stop procedures as related to the corn head.

Never leave the combine cab while the corn head is in operation.

Non-conforming use:

The corn head is designed only for harvesting in the direction of planting (row dependent) and for the specified row widths. Harvesting performance can greatly deteriorate if the corn head is used in other conditions for which it is not intended. Deterioration in performance can result if:

- The corn head is positioned too high or too low during harvesting.
- The corn head is used to harvest crops other than corn.

4. IDENTIFICATION AND SPECIFICATIONS

4.1. Identification

The universal mounting of the corn head permits it to be attached to specific combine types with the appropriate mounting kit. A mounting kit is assembled to the corn head at the factory as ordered.

A data plate is located on the left side of the corn head upper beam.

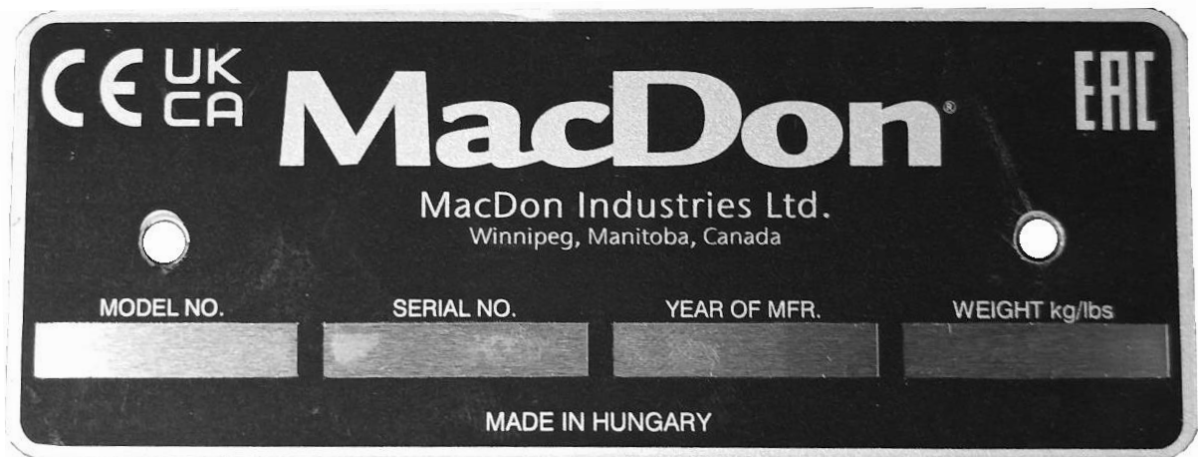

The model number refers to the following: for example:

- FC3012 12-row fixed frame with 30" row spacing
- FC3012C 12-row fixed frame with 30" row spacing and stalk chopper

IDENTIFICATION AND SPECIFICATIONS

4.2. Specifications

Dimensions

Row Spec	Model	Chopper	Weight		Width		Length (mm)	Length in shipping condition (mm)	Height (mm)	Height in shipping condition (mm)
			Kg	Lbs	mm	ft.				
12R30	FC3012	No	4693	10325	9180	30.1	2989	1350	1410	2275
	FC3012C	Yes	5083	11183	9246	30.32	2989	1350	1410	2275
16R30	FC3016	No	6025	13255	12245	40.2	2989	1350	1410	2275
	FC3016C	Yes	6295	13850	12320	40.42	2989	1350	1410	2275

Pitch of the gathering auger: 560 mm (22”).

Recommended Input shaft speed of the snapping unit drive: 550 rpm

Combine	Backshaft speed		Header Speed			
	Range	Rated	11 tooth	12 tooth	15 tooth	18 tooth
NH fixed drive	575	-	-	575	-	-
NH variable drive	402-575	550	-	402-575	-	-
JD fixed drive	520	-	567	-	-	-
JD variable drive	520-785	688	-	-	416-628	-
Case AFX fixed drive	602	-	-	602	-	-
Case AFX variable drive	460-690	596	-	460-690	-	-
Lexion fixed drive	761	-	-	-	609	-
Lexion variable drive	508-737	688	-	-	406-590	-

Note: Speed ranges shown in the chart above are actual feederhouse shaft speeds (which may not always match what is shown on combine monitor).

Length of chopped stalk: average 2” (50 mm), depending on crop conditions.

Hydraulic snapping plates are adjusted using the combine reel fore-aft controls.

Available row spacing: 30” (76.2cm).

5. MOUNTING THE CORN HEAD ON THE COMBINE

To prepare header for operation,

Begin by completing the unload and assembly instructions found in C series unload and assembly manual 215610.

The corn head is shipped from the factory with mounting kit installed as ordered. If the corn head will be mounted to a different combine than ordered, remove the factory installed mounting kit and install the required mounting kit as recommended for your combine with all the specified drive line shielding.



After the above operation and with the specified mounting kit securely attached to the Corn Head, engage and securely attach the Corn Head to the combine according to Combine Manufacturer's instructions. Engage the feeder lift cylinder safety stop and secure the lower latches.

5.1. Mounting the corn head on the combine

5.1.1 John Deere S series

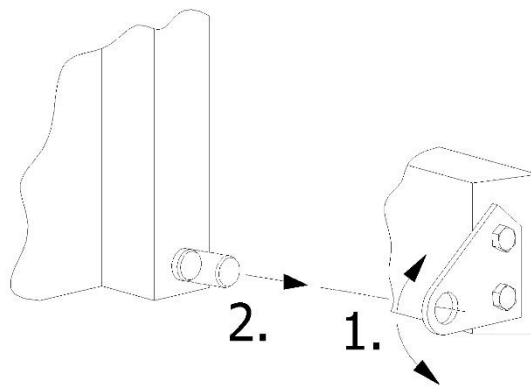

Insert the spring pivot pin (2) of the feeder house into the hole of the retainer plate (1) which is assembled on the lower support. If required, adjust the plate alignment.

MOUNTING TO THE COMBINE

5.1.2. CIH Flagship; NH CR & CX

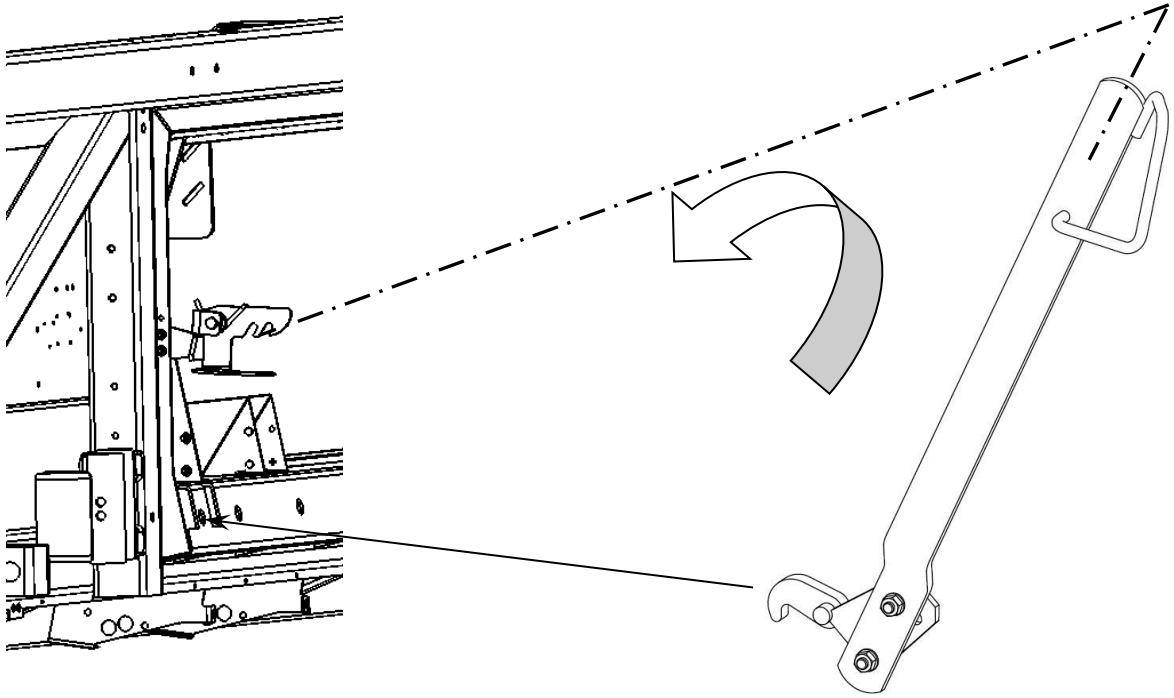

First, adjust the hooks on the combine until they are fully seated in the holes of the header. Next put the combine locking arm in the header latch and tighten the lower bolts.

5.1.3. Claas Lexion 700, 7000, & 8000 series

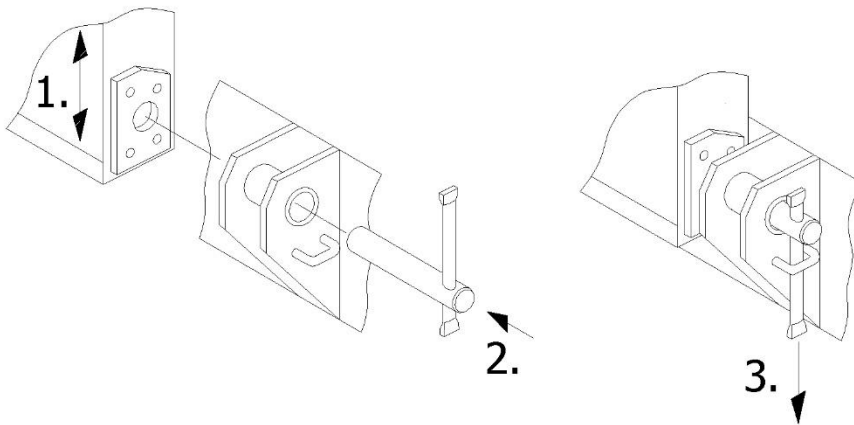

5.2. Connect Header Drive Shafts

Connect the drive shafts and ensure that the protective shields are properly in place and that all rotating parts are adequately shielded. The shafts are installed at the factory with protective shielding as supplied by the shaft manufacturer.



Position the protective shield of the drive shaft, according to the combine operator's manual, after connecting to the feeder drive shaft.

For use with a sidehill combine, CV driveshafts should be used. Correct drivelines for your combine configuration can be ordered through your MacDon Dealer.

To prevent the rotation of the header drive shaft shield, attach both original chain restraints to the corn head.



6. FLEXCORN HEADER SETUP

Before operating the FlexCorn header, the control system must be set up properly. Complete the following steps to set up the control system:

The FlexCorn system is compatible with the following displays via the ISOBUS Universal Terminal (UT, also known as ISOBUS Virtual Terminal—VT):

- John Deere 2630/GS3 CommandCenter
- John Deere Generation 4 4640/4600
- CaseIH Pro 700 (see note below)
- New Holland Intelliview IV (see note below)

Note: CaseIH Pro 700 and New Holland Intelliview IV displays must have ISOBUS Universal Terminal (UT) software installed. To install ISOBUS UT software, contact your local dealer and ask to have it installed. Without the UT software installed, the FlexCorn application will not be available through the combine display and the flex system of the header will not function.

Locate parts to be installed on combine. They are shipped in the wooden crate with the header.

- Battery power electrical harness MD#349343
- Combine cab harness MD# 349499

6.1 Wiring installation

1. Install battery power electrical harness (MD# 349343)

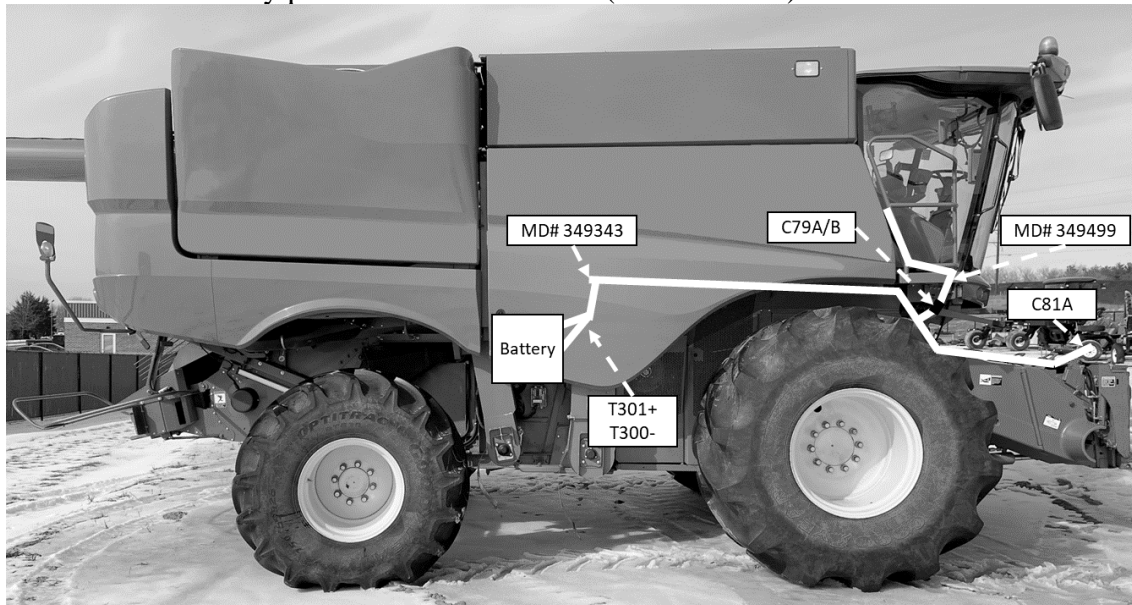

- a. Connect ring terminals (T301+ and T300-) to combine battery bus bar +12V and ground connections, respectively.

FLEXCORN HEADER SETUP

Note: if harness is connected directly to battery, battery disconnect switch won't disconnect power to FlexCorn control system. This could cause the system to always draw power from the battery and result in batteries losing their charge.

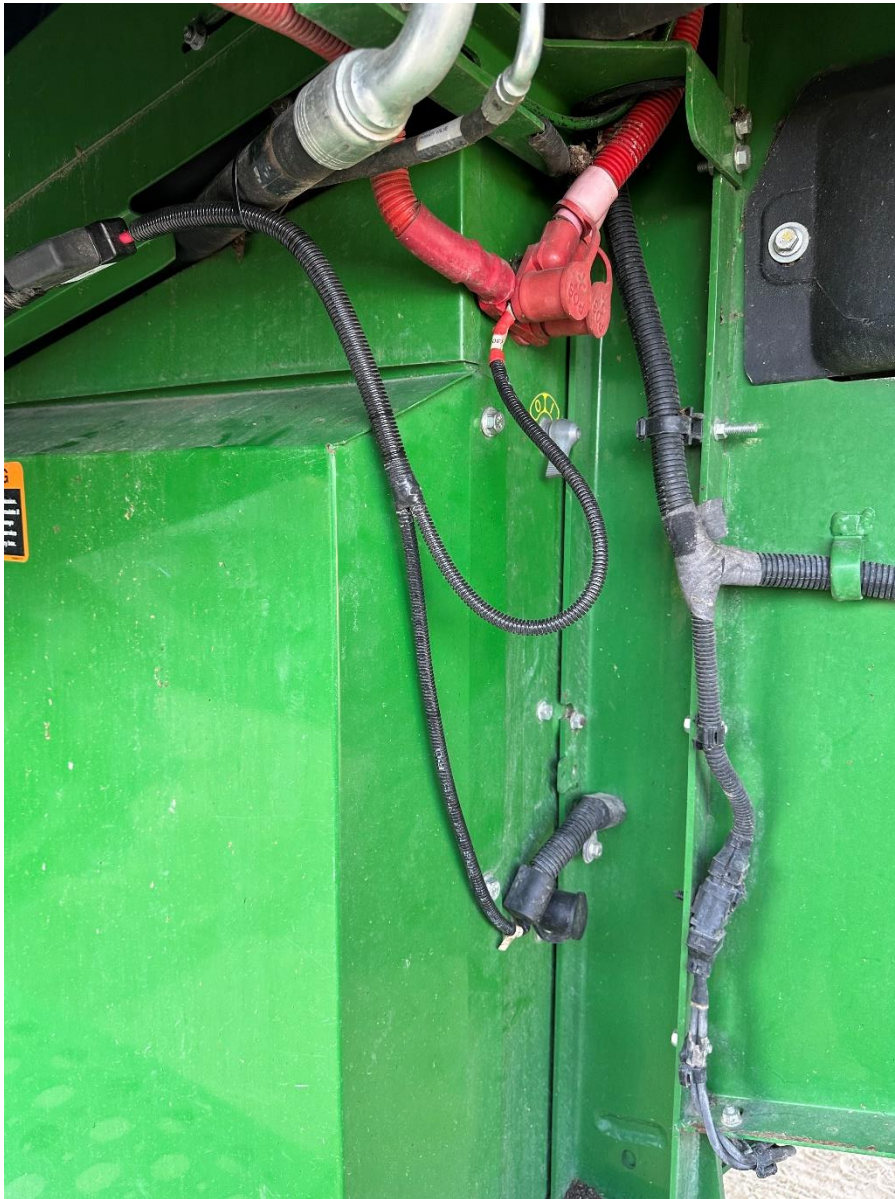

- b. Route harness from combine battery to the left side of the combine feeder house faceplate.
 - i. Position connector C81A about 1m (3 feet) past the left side of the combine feeder house near the header hydraulics connection to allow harness to reach the connection on the FlexCorn header.
- c. Connector C79A should be positioned appropriately to connect combine cab harness (MD# 349499) and route into the cab.

- d. Once harness has been routed appropriately, secure harness with cable ties every 0.3-0.6m (1-2 feet) to prevent movement and entanglement with moving components.
 - e. It is recommended to tie connector C81A to a safe location on the combine feeder house when the FlexCorn header is not in use to prevent damage to this harness.
2. Install combine cab electrical harness (MD#349499)
- a. With entire combine cab harness (MD# 349499) in the combine cab, identify a suitable location to route C79B out of the cab to connect to C79A on the battery extension harness (MD# 349343)
 - i. Consult the combine manual for the recommended routing of the harness into the cab.
 - b. Route connector C79B through the location identified in the previous step.
 - c. Connect C79B to the battery harness connector C79A.
 - d. Once harness has been routed appropriately, secure harness with cable ties to prevent movement and entanglement with moving components.
 - e. Connect J1939 diagnostic connector P800 to combine J1939 diagnostic connector.

Note: P801 is available on cab harness for other applications that may need the combine J1939 diagnostic connector

- f. Ensure connector PCAN-IB (implement bus) is connected to PCAN (CAN Config) and PCAN-VB (vehicle bus) is capped

Note: for some combines such as John Deere S6XX series, PCAN-VB should be connected to PCAN and PCAN-IB should be capped

3. Connect cab harness to Universal Terminal Controller (MD# 500306)
- a. Connect P513 to Universal Terminal Controller
 - b. Place Universal Terminal Controller in a safe location
 - i. Depending on the combine, some recommended locations are:
 - 1. Under cup holders, in storage compartments
 - ii. If desired, use double-sided adhesive tape or hook and loop tape to fasten controller to cab wall

Note: Universal Terminal Controller is powered by the control system on the FlexCorn Header. Without the header installed on the combine and the battery harness connected, the Universal Terminal Controller will not power on.

7. **HYDRAULIC SYSTEM SETUP**

7.1 **Adjust header relief pressure when used with John Deere combines with open-center reel drive systems.**

- **John Deere S650, S660, S670, S760, and S770 combines.**
- **Important:** John Deere S650, S660, S670, S760, and S770 combines use a lower reel drive circuit relief pressure than other combines that are compatible with the FlexCorn header. If the header will be used on one of these combines, the FlexCorn header hydraulic manifold relief setting needs to be reduced to prevent the combine reel drive circuit from exceeding its relief setting.
- **Note: Due to the lower reel drive circuit relief pressure setting on these combines, FC3016 and FC3016C FlexCorn headers are not compatible with John Deere combines using open center reel drive systems including S650, S660, S670, S760, and S770.**
- To use a 12 Row FlexCorn header on a John Deere S650, S660, S670, S760, or S770 combine the relief setting will need to be adjusted. Contact MacDon Harvest Support at 1 (204) 831-4422.

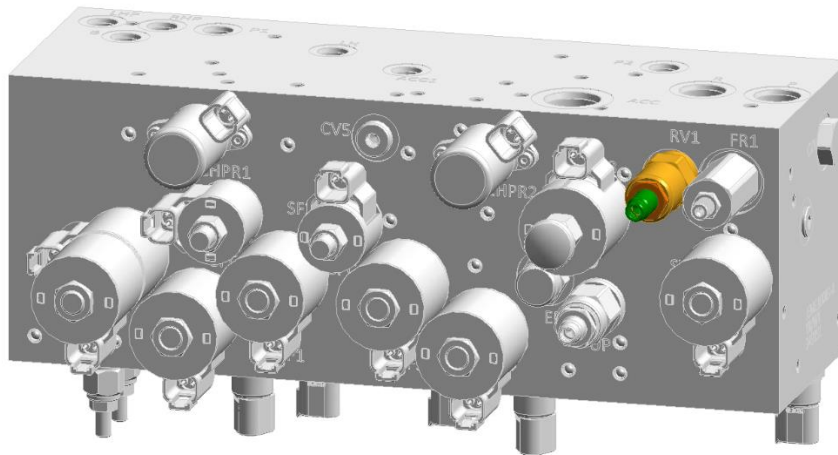

Note: if Rotary End Dividers are installed, they will stall if the combine reel drive relief setting is exceeded. If this occurs regularly, the header pressure relief setting needs adjustment. Contact MacDon Harvest Support at 1 (204) 831-4422.

7.2 Combine Multicoupler Diagram

The header hydraulics are powered by the combine reel flow system and reel fore/aft circuit. See combine multicoupler and corresponding valve block connection points.

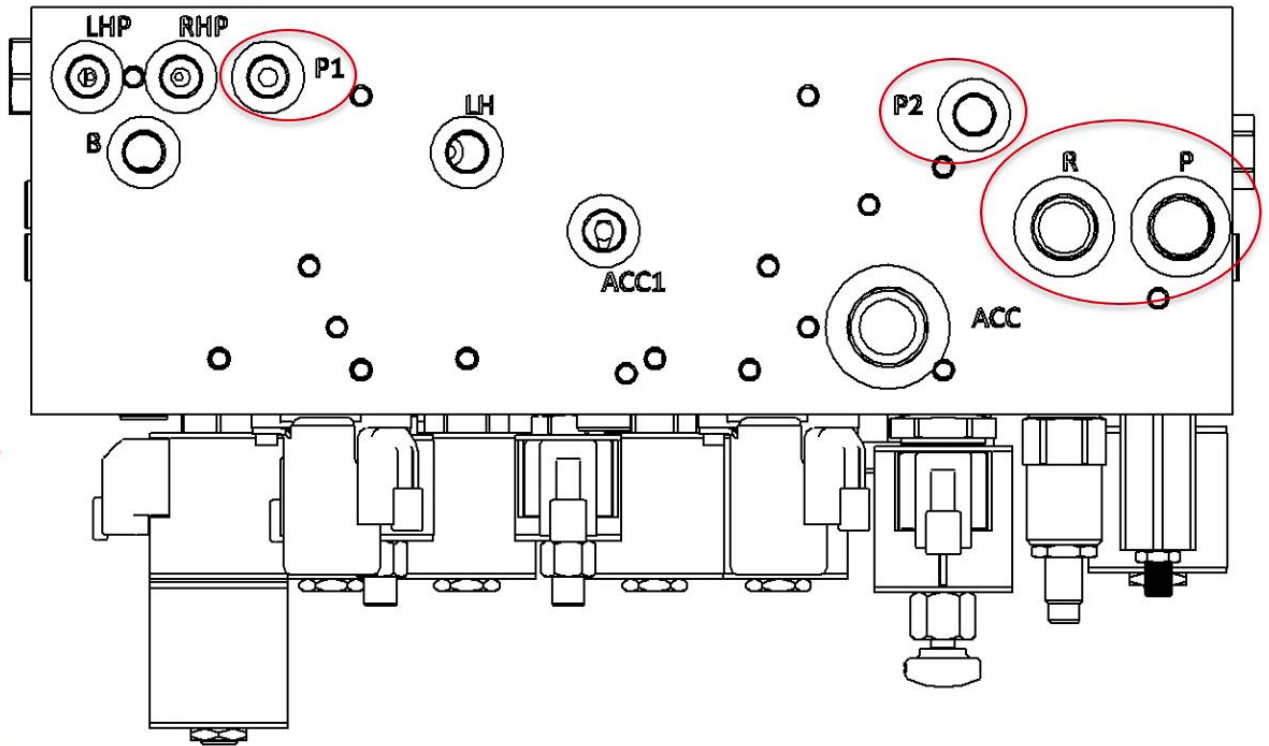
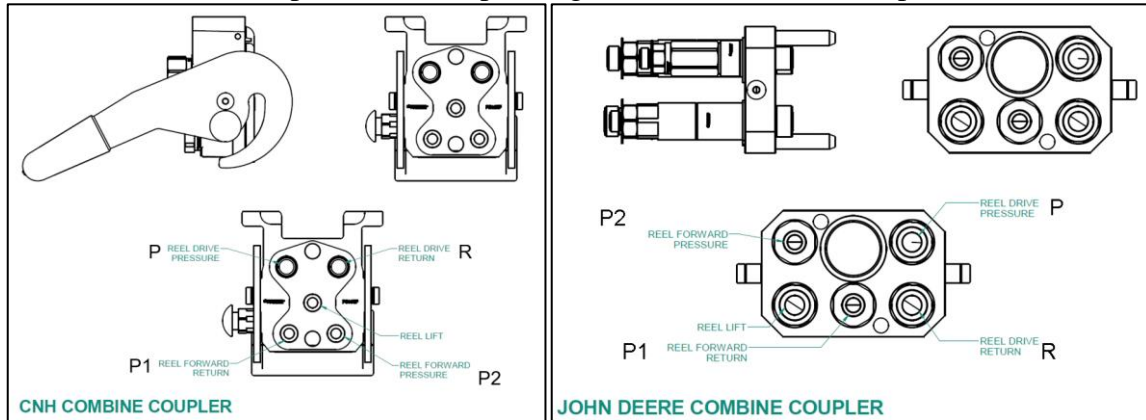

7.3 Control System Set-up

1. Connecting the FlexCorn header to the combine.
 - a. Pick up FlexCorn header with combine (*Section 4.1*)
 - b. Connect the combine single/multi-point connector to the header. Refer to the combine operator's manual for the correct latching methods.
 - i. Connect the drive shafts and ensure that the protective shields are properly in place and that all rotating parts are adequately shielded. The shafts are installed at the factory with the protective shielding supplied by the shaft manufacturer.

IMPORTANT:

- ii. After connecting to the feeder drive shaft, position protective shield (A) on the drive shaft according to the instructions in the combine operator's manual.
- iii. To prevent rotation of the header drive shaft shield (B), attach both original chain restraints (C) to the header.

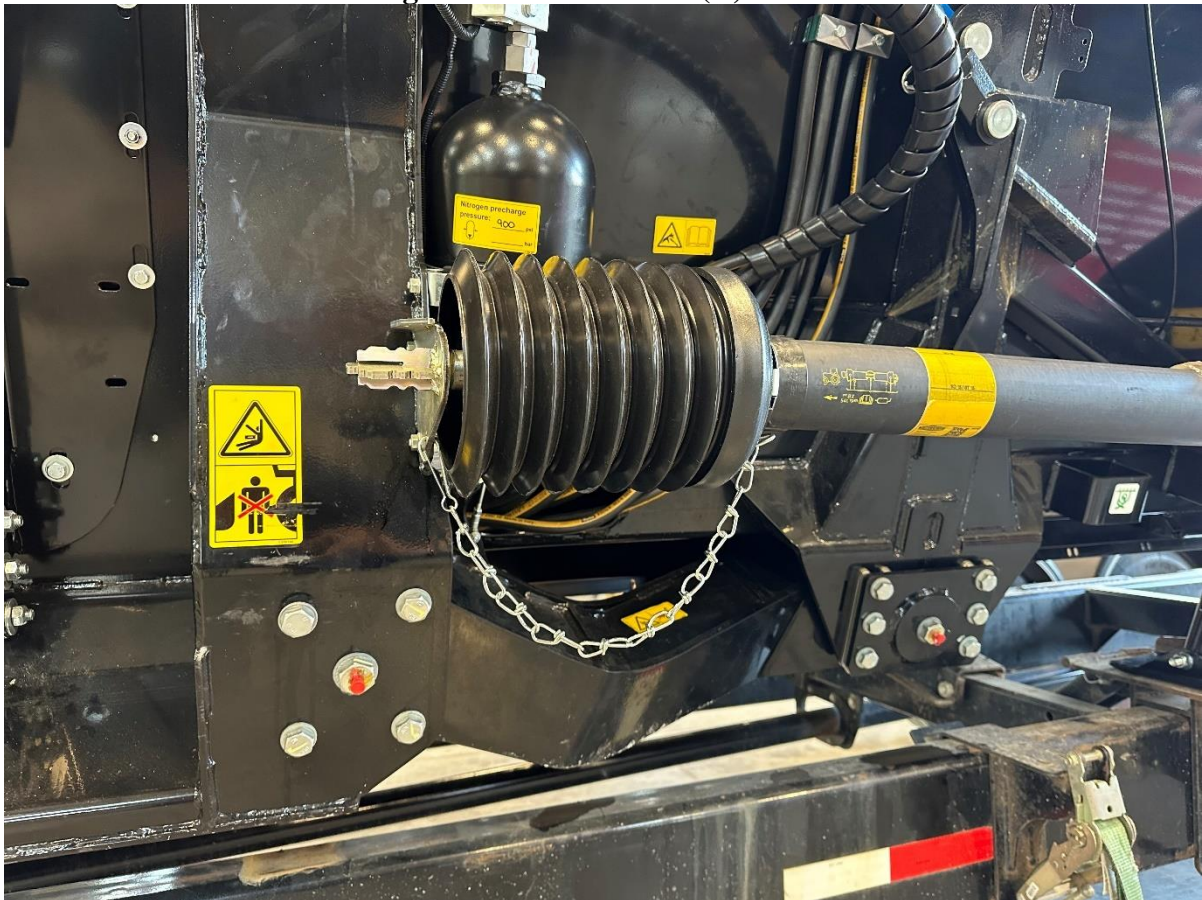

- c. Connect FlexCorn battery power harness (MD# 349343) C81A to header main harness (MD# 349883) C81B located on the header completion bulkhead.

2. Turn combine key to provide electrical power to FlexCorn system.
 - a. Lights should appear on header controller (MD# 500571) and Universal Terminal Controller (MD# 500572) indicating that they are powered on.
3. Allow up to 5 minutes for Universal Terminal Controller to upload FlexCorn Application to combine Universal Terminal

Note: If Application does not populate within 5 minutes, confirm:

- All cab connections are secure
- Universal terminal controller lights are on.
- If both of these conditions are met, swap connectors PCAN-IB and PCAN-VB to use an alternate CAN bus for connection.

- a. Depending on manufacturer and model, the upload progress will be indicated on the screen.
 - i. John Deere 2630 and GS3 Command Center:
 1. Select the menu button in the lower-right corner of the screen.
 2. All UT icons will appear in this menu.
 3. UT applications that are currently uploading will display with a green progress bar.
 - ii. John Deere Gen 4 Displays
 1. Select the menu button in the lower-right corner of the screen.
 2. Select the “Applications” button.
 3. Select the “ISOBUS VT” button.
 - iii. CaseIH Pro 700 and New Holland Intelliview IV Displays
 1. Navigate to the Home Screen
 2. Select ISOBUS
 3. Select VT

Note: with CaseIH Pro 700 and New Holland Intelliview IV Displays it is possible to choose between 6 or 12 visible softkeys. The FlexCorn UT application is optimized for 6 softkeys. Choosing 12 visible softkeys may cause issues with displaying some items on the screen. To change this setting:

- Navigate to the Home Screen
- Select the “Toolbox” button.
- Select the “VT” tab in the bottom of the screen.
- Select the dropdown menu labeled “Soft Keys”.
- Select “6” from the dropdown menu.

HYDRAULIC SYSTEM SETUP

4. Set-up according to specific FlexCorn Model in use.
 - a. Open the FlexCorn UT application on the combine UT. (see step 6.a)
 - i. John Deere 2630 shown here

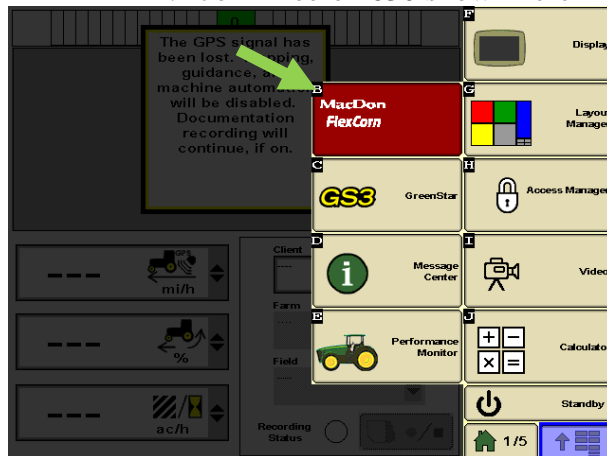

- b. Navigate to the "Setup" screen

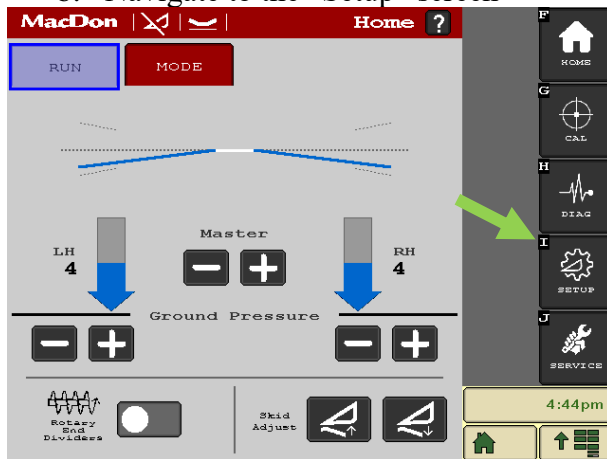

- c. If there are two or more displays installed in the cab, the FlexCorn UT application can be moved between screens.
 - i. To move to the next screen, press and hold the "Next VT" softkey in the "Setup" screen.

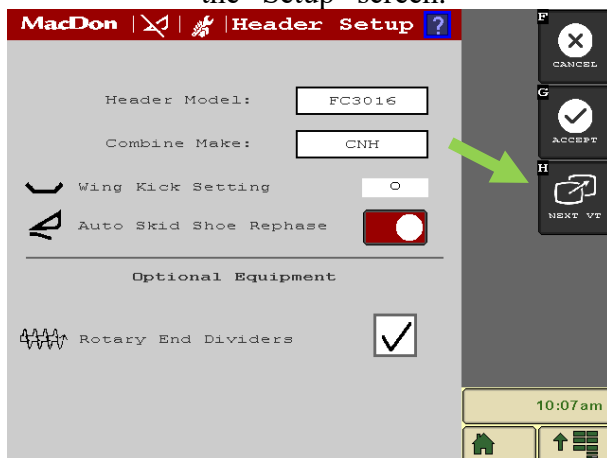

HYDRAULIC SYSTEM SETUP

- d. Select the appropriate header model from the “Header Model” dropdown menu.
- FC3012
 - FC3012C
 - FC3016
 - FC3016C

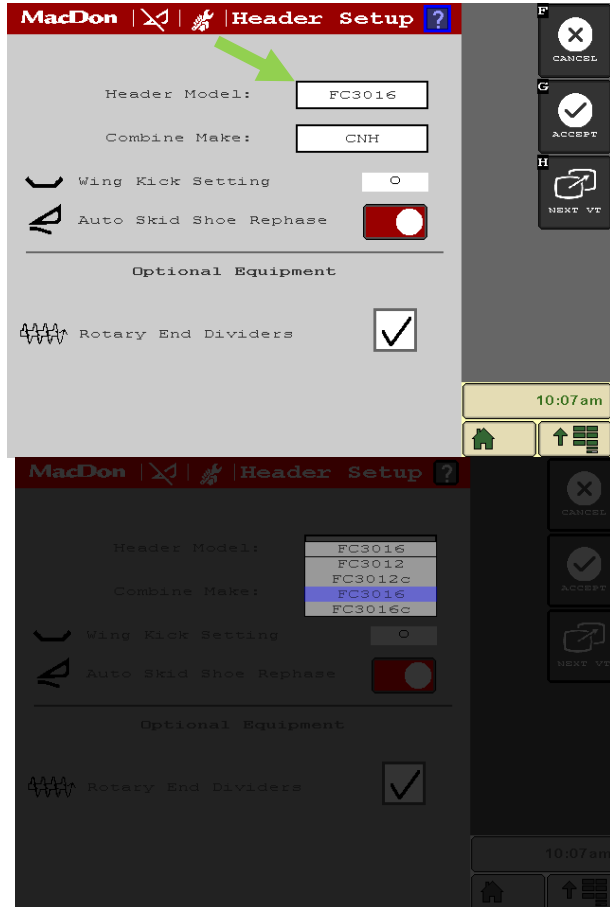

- e. Select the appropriate combine make from the “Combine Make” dropdown menu.

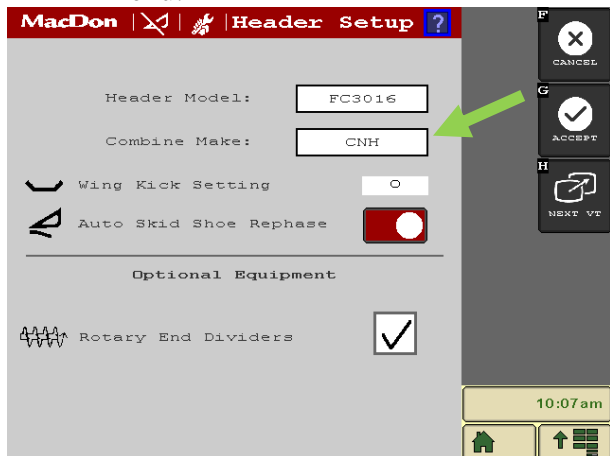

HYDRAULIC SYSTEM SETUP

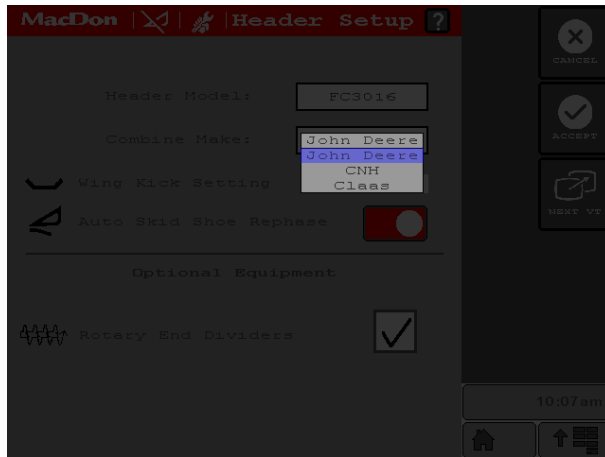

- f. Input the desired wing kick setting in the “Wing Kick Setting” numeric input box.
 - i. Wing kick is a feature that flexes the wings up when the header is operating in flex mode and is lifted off the ground. Wing kick helps avoid contact with the ground and standing crop by providing more clearance between the header wings and ground.
 - ii. This setting can be adjusted between 0% (wings level) and 75% (wings flexed up 75%)

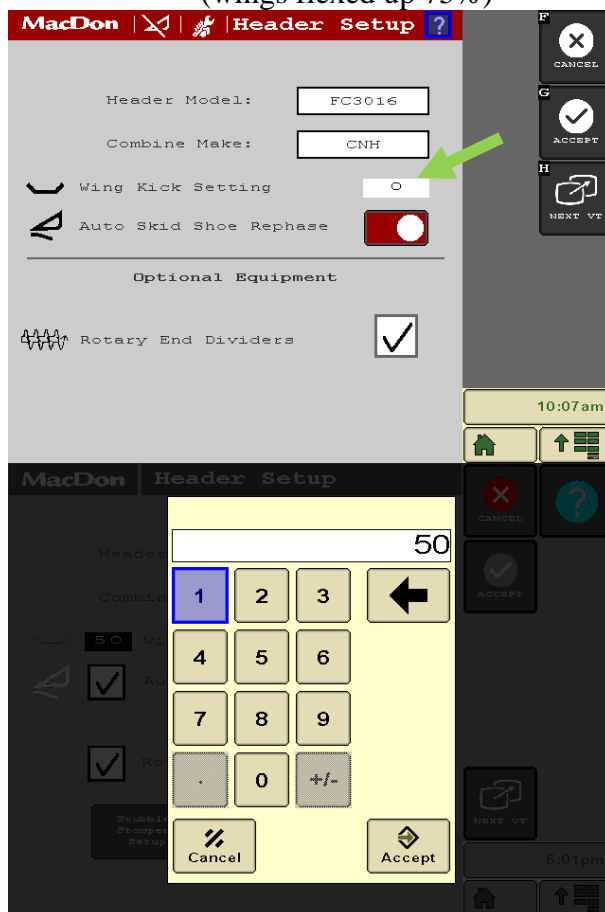

HYDRAULIC SYSTEM SETUP

- g. Select the appropriate optional equipment check boxes.
 - i. Rotary End Dividers
 - 1. If Rotary End Dividers (REDs) are installed select this box
 - 2. If Rotary End Dividers are not installed, clear this box.

WARNING: if Rotary End Dividers are not installed, but this box is checked, the FlexCorn header may cause the combine hydraulic reel drive to exceed relief pressure and will not operate as expected (If both the Tall End Dividers and Rotary End Dividers are installed, make sure Rotary End Dividers are disabled)

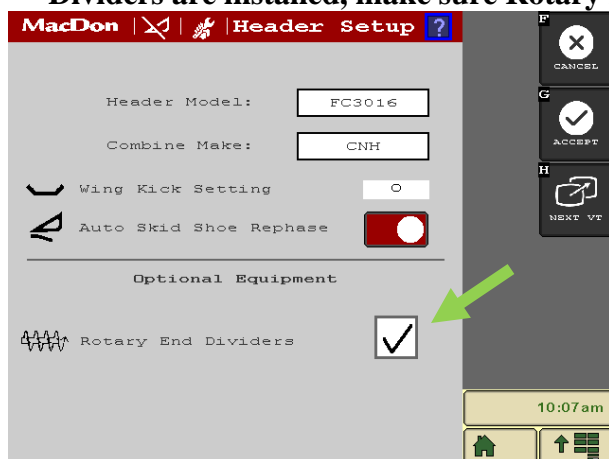

- h. Once setup is complete, select the "Accept" softkey to save the settings.

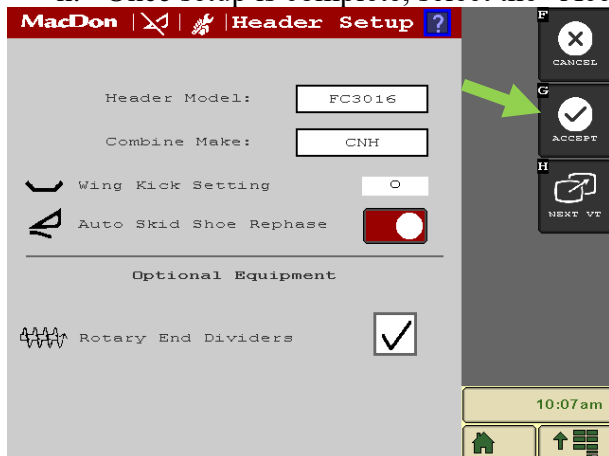

- i. To exit the Header Setup without saving the settings, select the “Cancel” softkey.

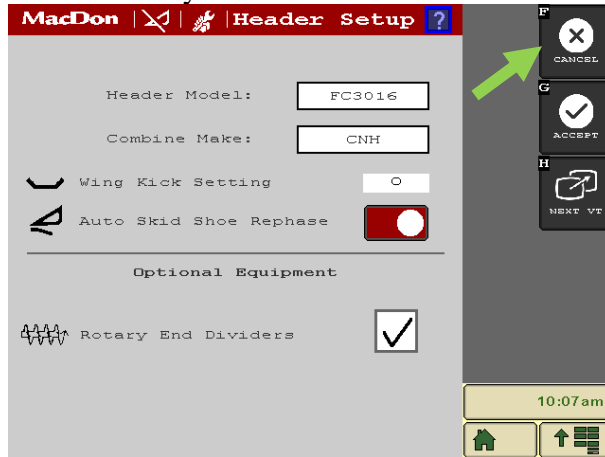

5. Add FlexCorn Universal Terminal to combine run screens.
 - a. Most combine displays allow for ISOBUS UTs to be added to run screens.
 - b. Follow instructions in combine or display manual.
6. Enable combine reel drive circuit.
 - a. The combine reel drive circuit powers the flex system of the FlexCorn header and also powers Rotary End Dividers (REDs), if installed
 - b. Follow combine instructions to ensure the combine hydraulic reel drive circuit is enabled (*see combine manual for instructions*)

Note: If combine reel circuit (sometimes called header aux function) is disabled or the speed setting is turned all the way down, the Flex system will not function. The combine reel circuit must be enabled!
for Claas combines this requires connecting the two single wires at the header side of the combine multicoupler.

7. Set Rotary End Divider (RED) Flow
 - a. Headers with Rotary End Dividers:
 - i. Set the reel speed to a middle setting and visually check to ensure REDs are spinning at a consistent speed.
 1. The reel flow should be 4-7 gpm depending on the desired speed of the REDs.
 - ii. Increasing or decreasing the reel speed setting will speed up/slow down the REDs like usual, but reel flow should never be decreased to turn REDs off
 - iii. If it is desired to turn REDs off, do so by selecting the “Rotary End Divider” button on the Main Run Screen of the UT application.

Warning: If REDs are turned off by using the reel speed control, the flex system will not function. This will lead to poor performance and possible header damage.

- b. Headers without Rotary End Dividers (REDs) ONLY:
 - i. The reel flow should be set to 3-4 gpm. To set reel flow:

- ii. Place header in Service Mode (See 9.2.7 *Harvesting* → *Control System/Operator Interface* → *Service Mode*)
- iii. In the Setup screen:
 - 1. Enable REDs
 - 2. Press “Accept”
- iv. In the main Run screen, make sure RED ON/OFF button is enabled.
- v. In the Diagnostic screen, find the “Input Pressure” reading.
- vi. Engage combine separator and feeder house/header drive.

Warning: Clear area around header before engaging the combine.

- vii. Set reel speed to its lowest setting.
- viii. Slowly increase reel speed setting until the input pressure increases above 1000 psi.
- ix. In the Setup screen:
 - 1. Disable REDs
 - 2. Press “Accept”
- x. Ensure that reel speed setting is not accidentally adjusted while using FlexCorn header.

8. Calibrate header.

NOTE: to cancel a header calibration at any time, select the “Cancel” softkey on the Calibration screen

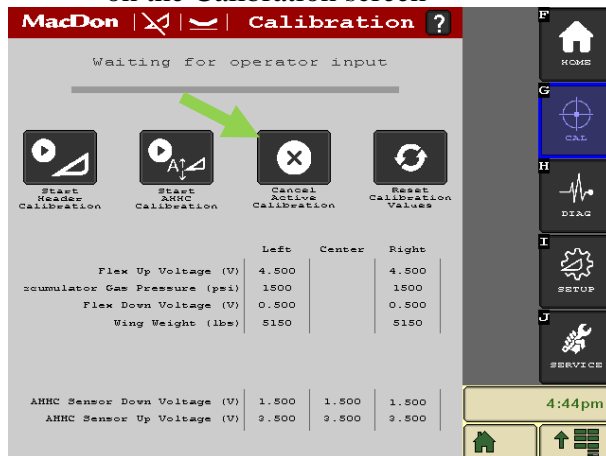

- a. Make sure the combine is on level ground before calibrating.
- b. Make sure the snapping plate angle is set to 23 degrees. See Section 8.8
- c. Lift the combine feederhouse as high as possible.
- d. Select the “CAL” softkey to navigate to the Calibration screen.

HYDRAULIC SYSTEM SETUP

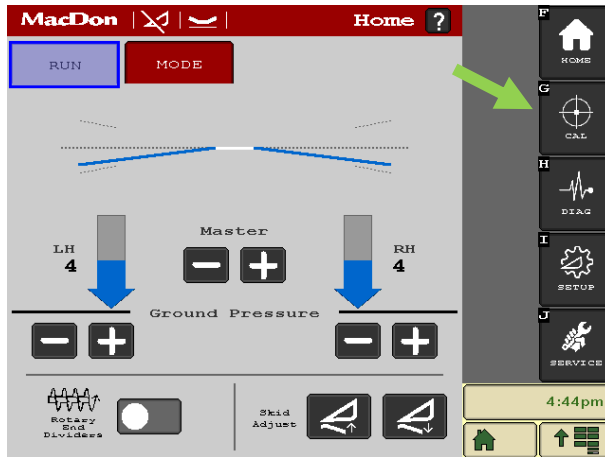

- e. Start the header.
- f. Select the “Start Header Calibration Softkey”

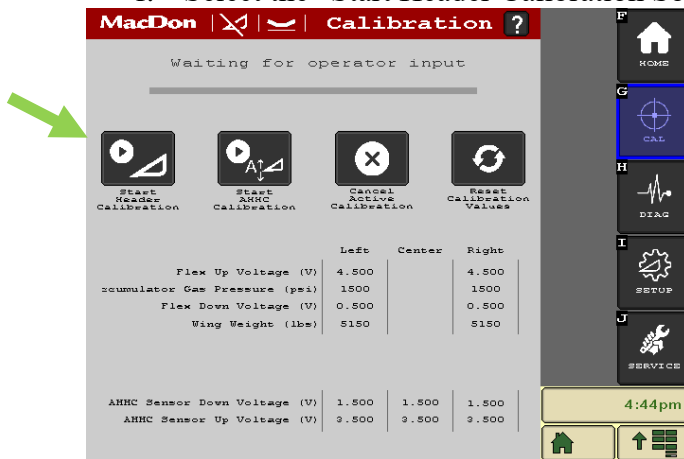

- g. The header calibration will proceed automatically.
- h. The Calibration Status Message will update with the current step in calibration sequence.
- i. The Calibration Progress Bar will fill as the calibration progresses.
- j. When the calibration sequence is complete, the status bar will fill completely, the status message will read “Successful Calibration” for a few seconds, and the new calibration values will appear on the screen.



9. Calibrate header Automatic Header Height (AHHC) System

NOTE: to cancel an AHHC calibration, select the “Cancel” softkey on the Calibration screen at any time

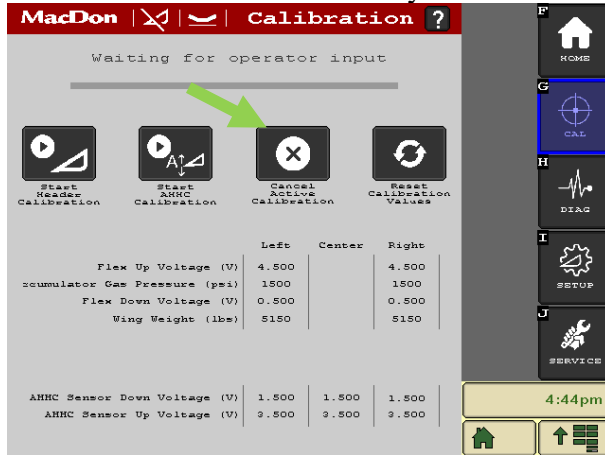

- Make sure the header is on flat and level ground before calibrating the AHHC system.
- Make sure the header snapping plate is set to 23 degrees. See Section 8.8
- Select the “Start AHHC Calibration” softkey.

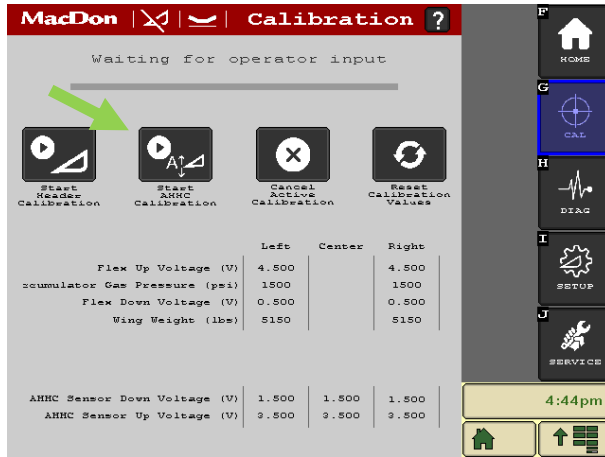

- This calibration requires input from the operator to proceed.
- The Calibration Status Message will update with the current step in calibration sequence as well as instructions for the operator to follow.
 - First, the operator will be asked to lower the header to the ground and hold.

HYDRAULIC SYSTEM SETUP



ii. Then, the operator will be asked to lift the header off the ground fully.



f. When the calibration is complete, the wings will be levelled and locked rigid to proceed with the combine AHHC calibration and the status message will read: "Success: wings locked for combine calibration".

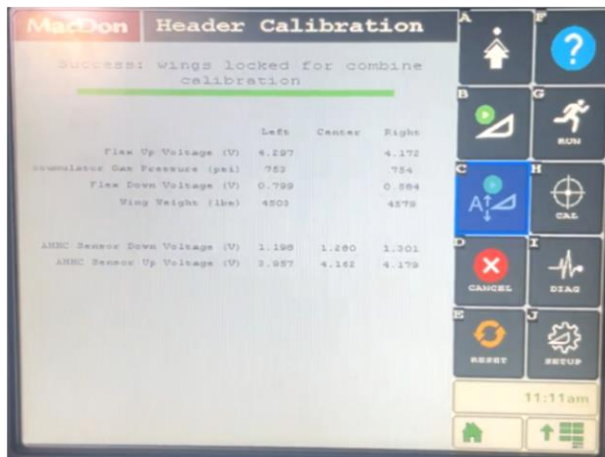

10. Calibrate the combine AHHC and lateral tilt systems according to the combine manufacturer's instructions.

11. The header is now set up and ready for operation.
 - a. The header settings and calibrations will be saved to the header controller memory, so these steps only need to be repeated in the following cases:
 - i. Header is used on a different combine.
 - ii. Header configuration changes
 1. Optional accessories (such as Rotary End Dividers) are added or removed.
 - iii. Calibrations are reset to factory settings.
 - iv. Header controller is replaced.

8 HEADER START-UP PROCEDURE

A 30 minute “trial run” is suggested after the initial mounting.

Start the combine and momentarily engage the drive with the engine speed at low idle, If all sounds well, run the corn head slowly. Avoid starting the drive at high engine speed as the inertia load from acceleration can be 8-10 times more than the load from steady speed operation. High-speed start-up may cause damage to the drive system and safety clutches.

After the slow speed start, increase the engine speed to a medium level and listen for abnormal sounds. If no irregularity is observed, the engine speed can be increased to maximum level.

Cycle snapping plates fully closed to fully open several times to ensure proper function.

9. SETUP PROCEDURE AND ADJUSTMENT OF THE CORN HEAD

9.1. Parking stands

The corn head is provided with parking stands which must always be used when it is to be disconnected from the combine. Before detaching the corn head from the combine, adjust the parking stand position such that the distance between the ground and the lower support of the corn head is about 30 cm (12 inches).

Adjust the stand position by removing and replacing the retaining pin and re-installing the hairpin.

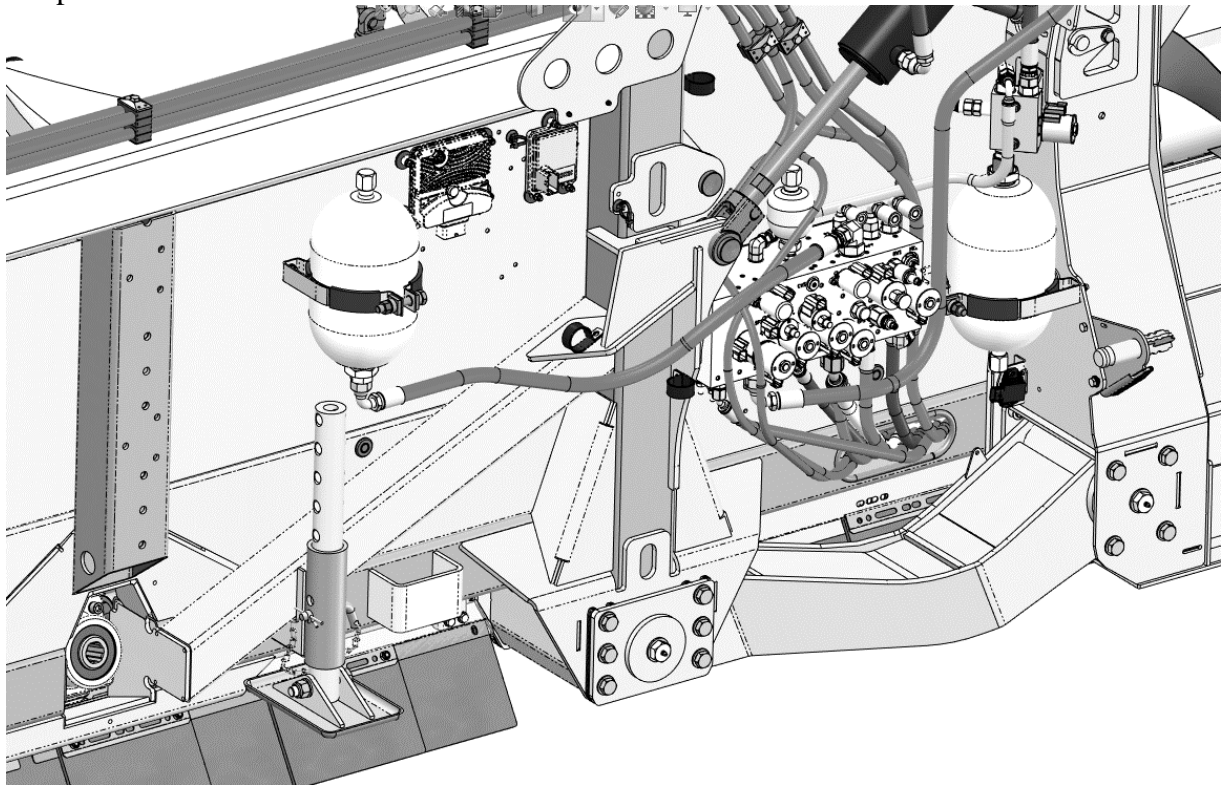

9.2. Auger

The auger is driven through a torque-limiting clutches that can disengage excessive loads on the drive. These clutches are located below the large 70T auger sprocket on the left and right ends of the header.

In some conditions it may be necessary to change the speed of the auger. The driver sprocket can be reversed to provide an alternate speed to suit field conditions.

12 and 16 row FC headers will be shipped with both 18T/20T and 16T/18T sprocket.

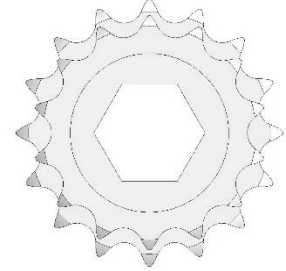

Note: The 18T/20T sprocket can only be used as a 20T due to interference with the frame. If an 18T sprocket is required, use the 16T/18T sprocket provided in the wooden crate.

Use the faster speed for normal conditions and the slower for slower ground speeds or lodged conditions.

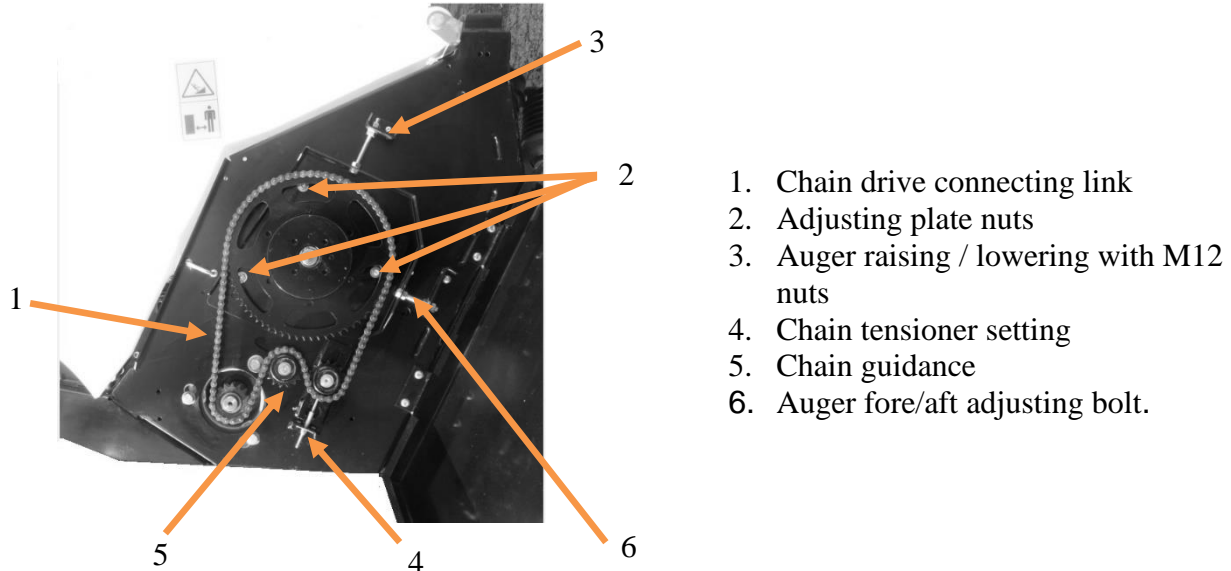

To adjust auger position, loosen bolt 2 (3x, each side) and use bolt 3 and bolt 6 to move auger. Once positioned, retighten bolt 2.

If auger is moved, be sure to check and adjust chain tension.

Gap between flighting and auger pan at minimum clearance.

Check factory setting 32-38 mm (1.25" - 1.5")

Check clearance at both ends of auger and adjust if necessary.

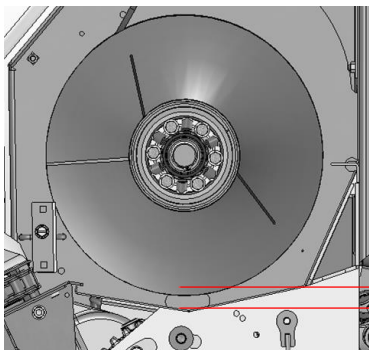

32-38 mm (1.25" - 1.5")

SETUP PROCEDURE AND ADJUSTMENT OF THE CORN HEAD

- Augers will come standard from factory with reverse flighting installed.
- Options include fingers/paddles in place of reverse flighting.
- Fingers are recommended in very dry, fluffy corn where positive conveyance to the feederhouse is needed.
- Paddles can be installed over the fingers if wrapping becomes problematic.

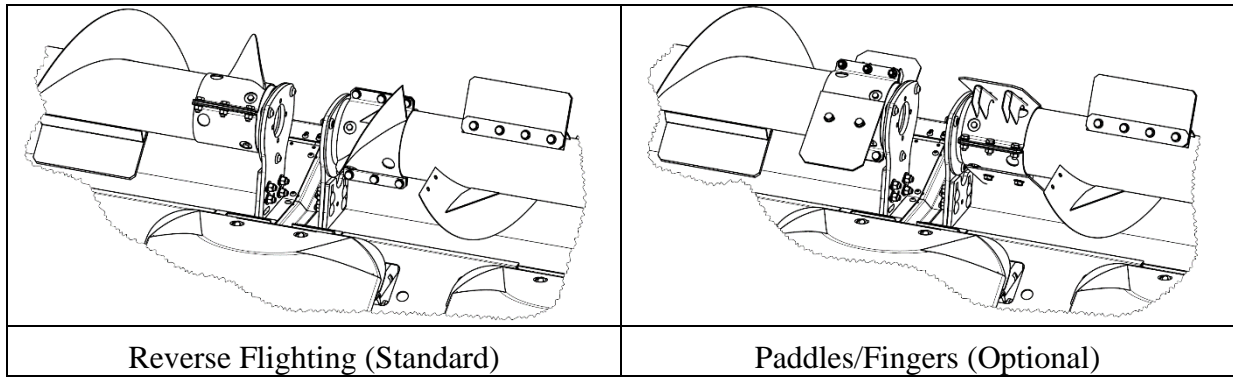

Reverse flight tailing edge should be 180 degrees offset from forward flight tailing edge.

9.3. Auger Timing:

9.3.1. Dual Auger Drive Time (Double Auger)

- Flighting should be offset by 180°.
- To adjust:

Remove, rotate, and reinstall the RH drive shaft from the combine backshaft to the desired position. Alternatively, remove auger drive chain and rotate auger to desired position and reinstall chain.

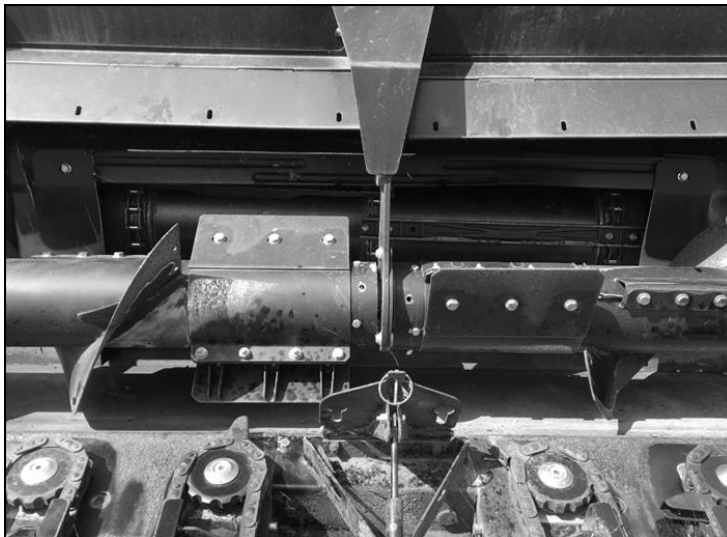

9.4. Gearbox Drive

The drive and driven gearboxes are connected by a double joint coupling drive or shaft (1) depending on the combine. The gearbox assemblies (2) are selected to provide a nominal snapping unit input speed of 550 rpm for each combine. Gearboxes can be exchanged as necessary.

See appropriate combine conversion document for complete instructions

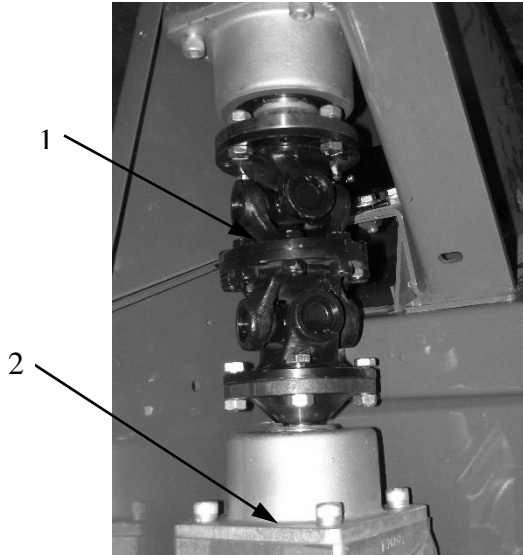

Double joint coupling
(all except Claas)

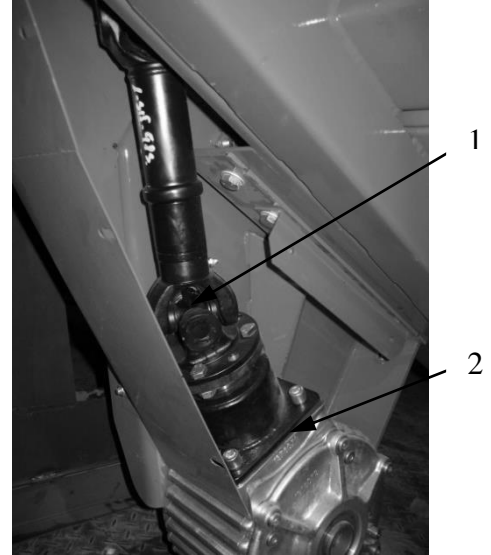

Shaft-drive
(Claas)

9.5. Snapping units

9.5.1. Snapping rolls adjustment

Three important settings must be observed when installing or adjusting the snapping rolls.

9.5.1.1. Snapping roll clearance

Adjust front of stalk rolls so there is a 1 mm gap between opposing knives (Labeled B). The rear portion of the roll is not adjustable.

After any adjustment, be sure to rotate the rolls to ensure the knives are clear of each other and clear of the vine knives (Section 9.5.3).

To make the adjustment, adjust one snapping roll at a time. Slightly loosen the bolts holding the snapping roll front support (Labeled A), adjust the roll and Torque nuts to 45 Nm (33 lbf•ft).. Adjust each roll an equal amount to keep them centered in the row unit.

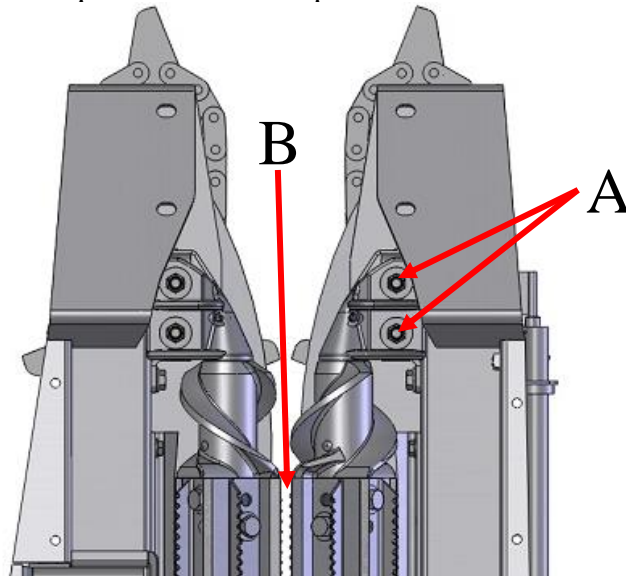

9.5.1.2. Labyrinth

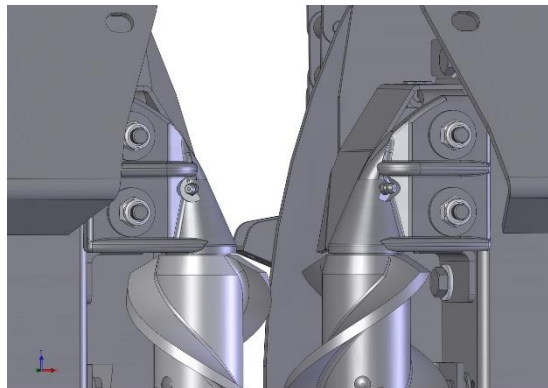

Two sealed double ball bearings are used to support the spiral end of the snapping roll. The bearings are protected by a labyrinth filled with grease. The labyrinth can be flushed by adding grease through the grease nipple

9.5.2. Snapping plate adjustment

9.5.2.1 Setting fixed snapping plate

For proper operation, the snapping plate gap should be 5 mm (3/16") tighter at the front than at the rear. Set the mechanism as follows:

Set the in-cab snapping plate adjusting mechanism to the minimum snapping plate gap with the hydraulic or electrical controls.

The fixed snapping plate can be adjusted in two ways:

Use snapping plate tool (PN 1.369.047) and adjust fixed plate over until it lightly contacts the stopping tabs.

Adjust the fixed snapping plate until the gap at the front measures 3/4" (19 mm) and the gap at the rear measures 15/16" (24 mm)

To make adjustment, loosen bolt 3 (4x) shift snapping plate into correct position, and retighten.

9.5.2.2 In cab snapping plate adjustment

Adjust snapping plate gap from the cab to approximately 1/8" larger than corn stalk size.

Fine tune based on field and crop conditions.

Too much excess stalk material - adjust snapping plates further apart.

Crop lost between snapping plates- adjust snapping plates closer together.

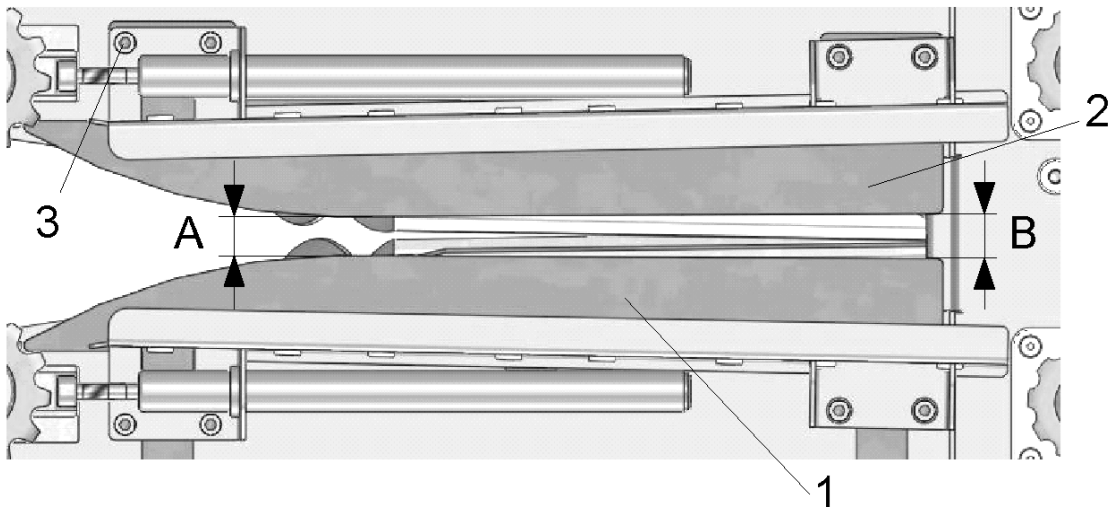

SETUP PROCEDURE AND ADJUSTMENT OF THE CORN HEAD

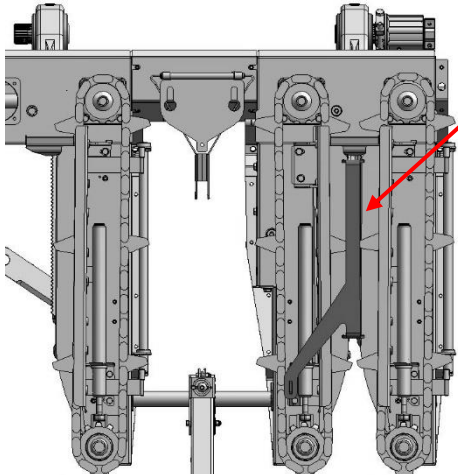

The snapping plate tool (PN 1.369.047) is used to help set the snapping plate clearance. This tool can be ordered from your dealer. The Snapping Plate Tool's application is shown on the picture.

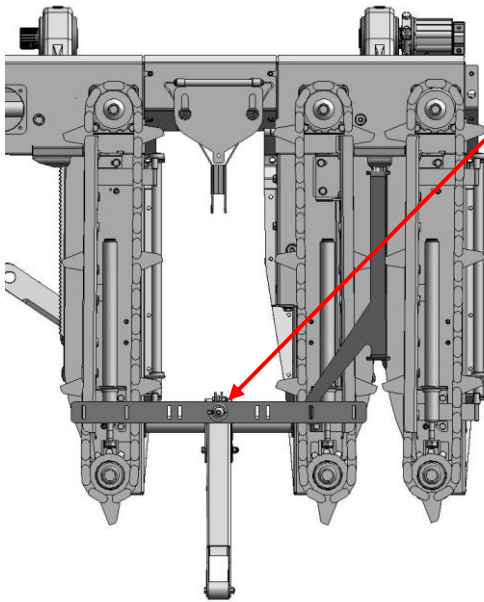

There is a tool (Snout Seating Tool – PN 1.369.048) that can be placed between the two brackets while setting the snapping plate clearance, so the snouts align with the brackets after they are tightened down. This tool can be ordered from your dealer.

9.5.3. Vine knife adjustment

The gap between the vine knives (1 and 2) and the stalk rolls should not exceed 1 mm (.04"). This gap should be set on one rib and all rib clearances should be checked by rotating the rolls to ensure there is no interference. Adjustment is made by loosening the (4x) M-8 screws (3).

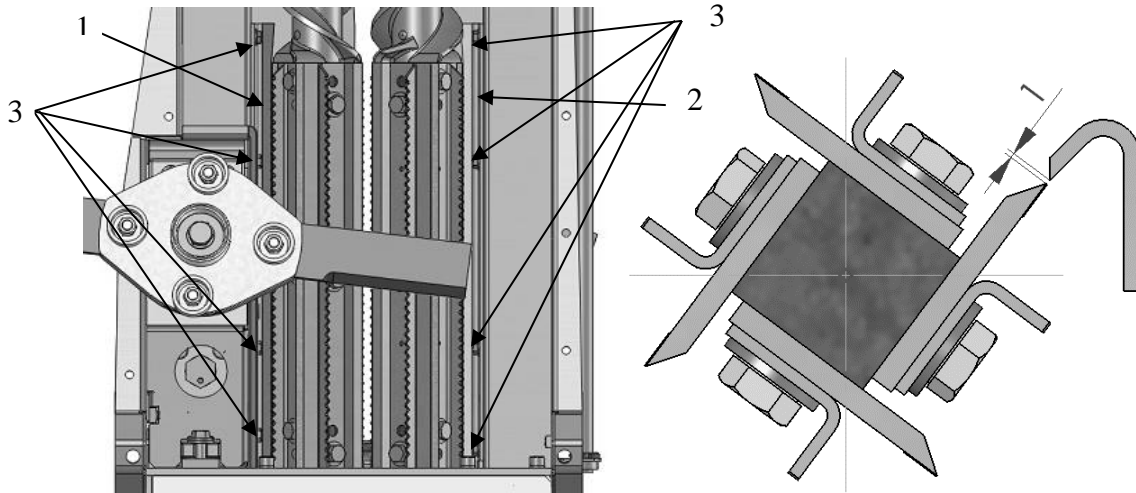

9.5.4. Snapping Roll Rebuild

The snapping gauge tool (PN 1.369.049) helps set the position when replacing knives. To use the tool, stalk rolls should be removed from the header for replacement.

To adjust the knife to the proper position, leave the bolts slightly loose and slide the knife until it gently contacts the tool. Next, fully tighten the bolts. Repeat for all four knives.

If damaged, knives should be replaced in groups of 4 to maintain balance and clearance between the rolls.

Upon reinstallation be sure to rotate the snapping rolls to check clearance between each roll and between the roll and the vine knives. (Section 6.5.3)

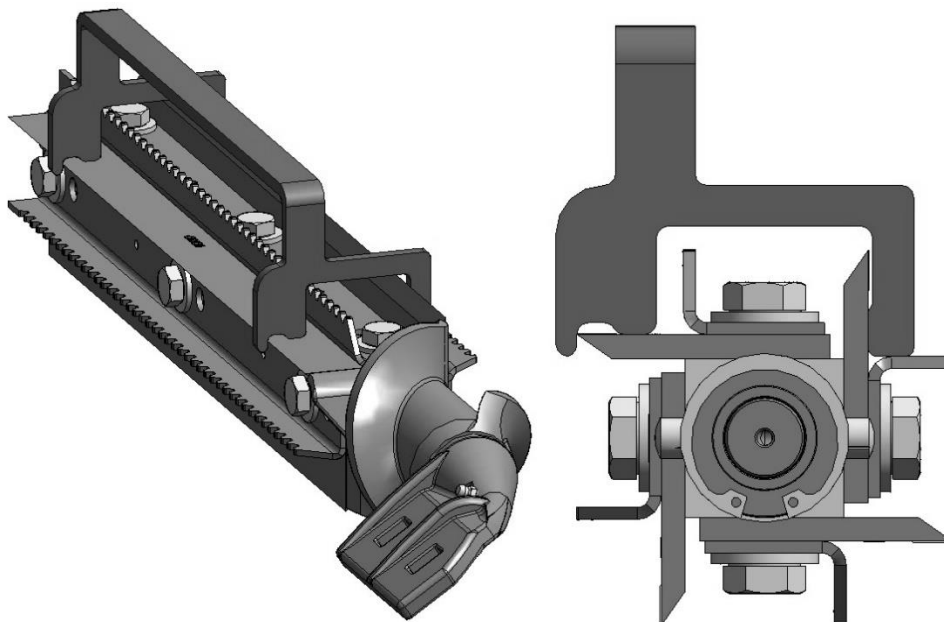

9.5.5. Gathering chain adjustment

The gathering chain tension is maintained automatically by an enclosed spring on the front idler. A tool is provided to compress the spring for service.

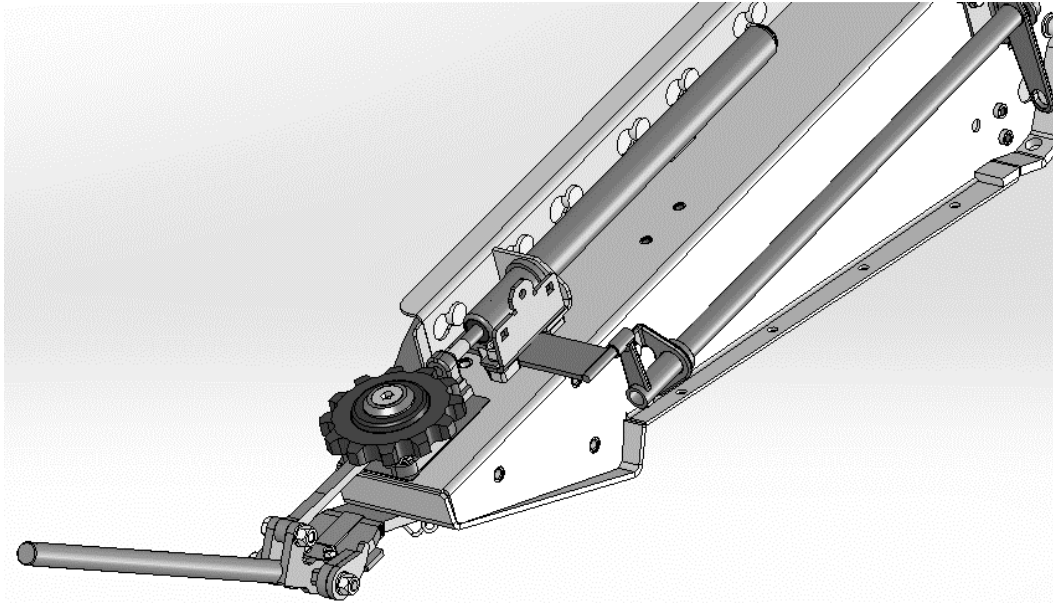

How to use the gathering chain removal tool:

1. Install the gathering chain removal tool and attach it in the holes on the bottom of the snapping unit frame.

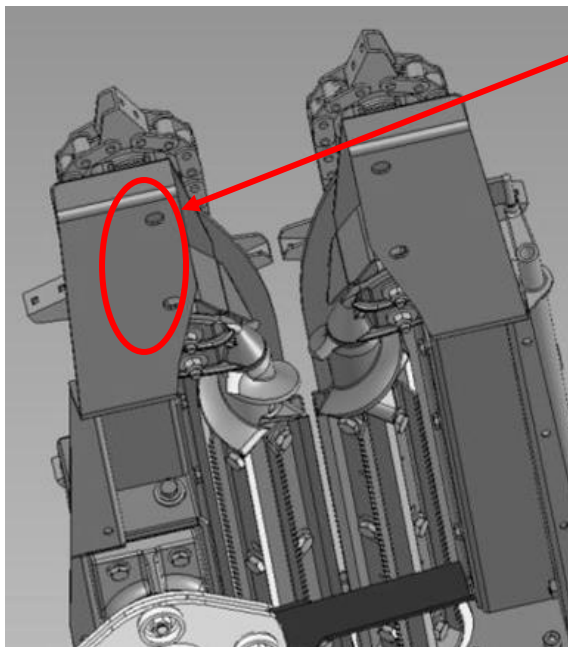

SETUP PROCEDURE AND ADJUSTMENT OF THE CORN HEAD

2. Position the arm of the gathering chain removal tool into the carriage. (marked surface)

Rotate the handle of the removal tool and lock it in place once tension on the gathering chain is relieved.

Remove the gathering chain.

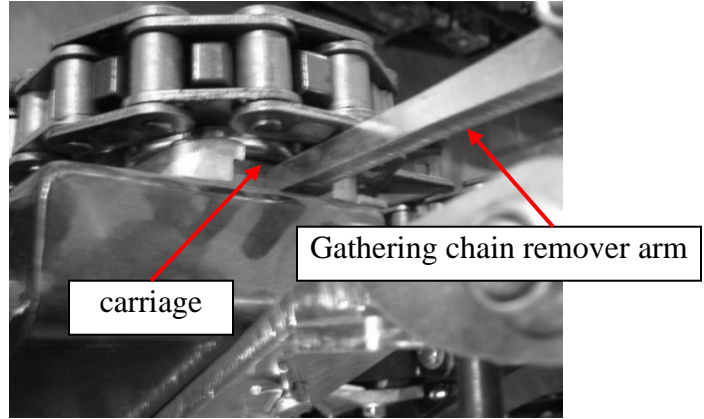
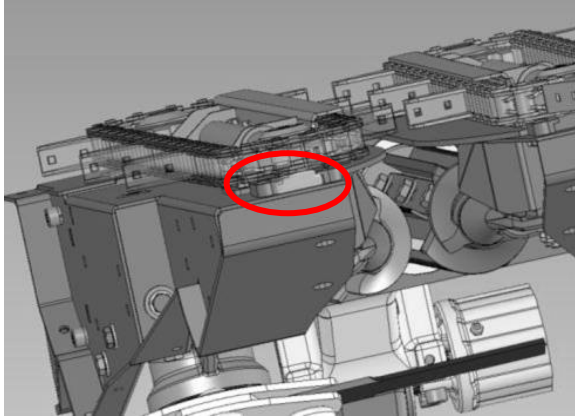

Gathering Chain Lug Timing:

The gathering chain driver sprockets have reduced height to protect the gearbox internals if a foreign object is encountered in the field. As a result, it is normal for gathering chain timing to shift while harvesting.

9.6. Header Drive Shafts

9.6.1 Conventional Driveline Service

The Walterscheid brand drive shafts require lubrication every 100 operating hours.

Remove the shaft annually and grease it according to the label instructions provided by the shaft manufacturer on the shaft cover.

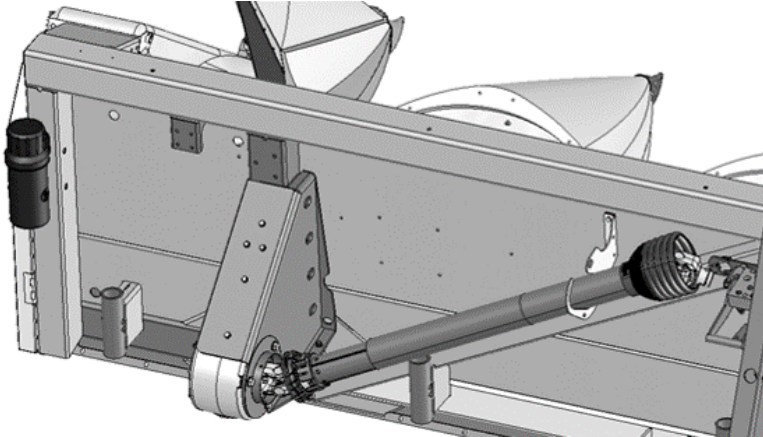

		W		
		1	2	3
W1		100 h		100 h

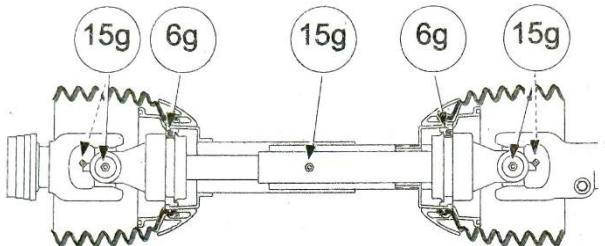

Note: Grease quantities in grams. 1 stroke is equal to 3 grams.

9.6.2 CV Driveshaft Service

If equipped with a CV driveline, grease with the following intervals.

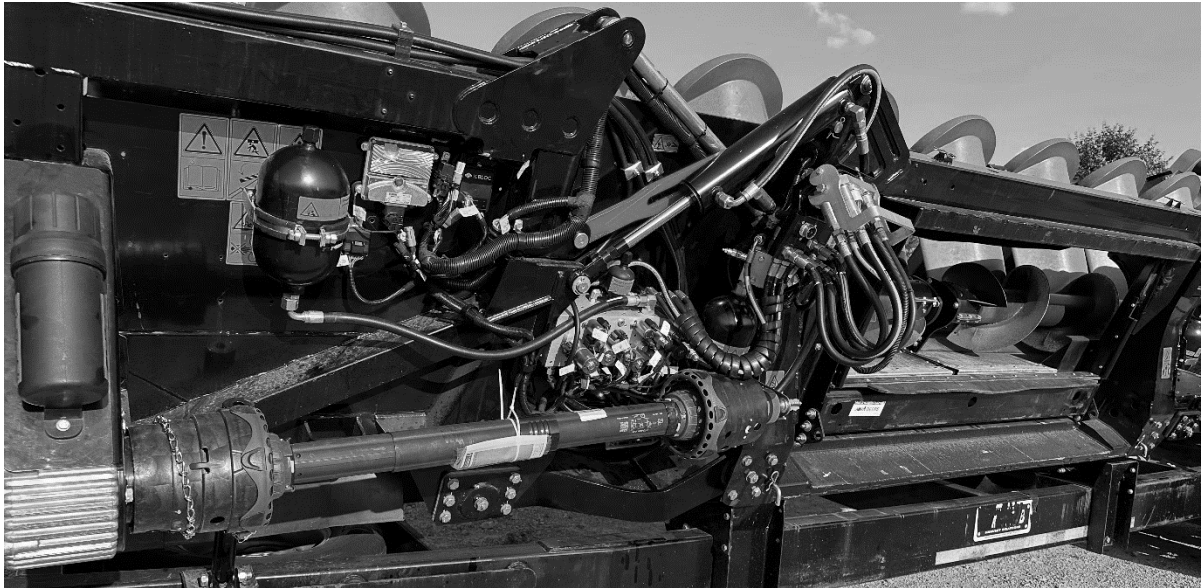

		WWE/WWZ		
		1	2	3
W1		8 h		60 h

Grease quantities in grams. 1 stroke is equal to 3 grams.

9.7 Adjustment of the corn head

9.7.1 Header angle adjustment

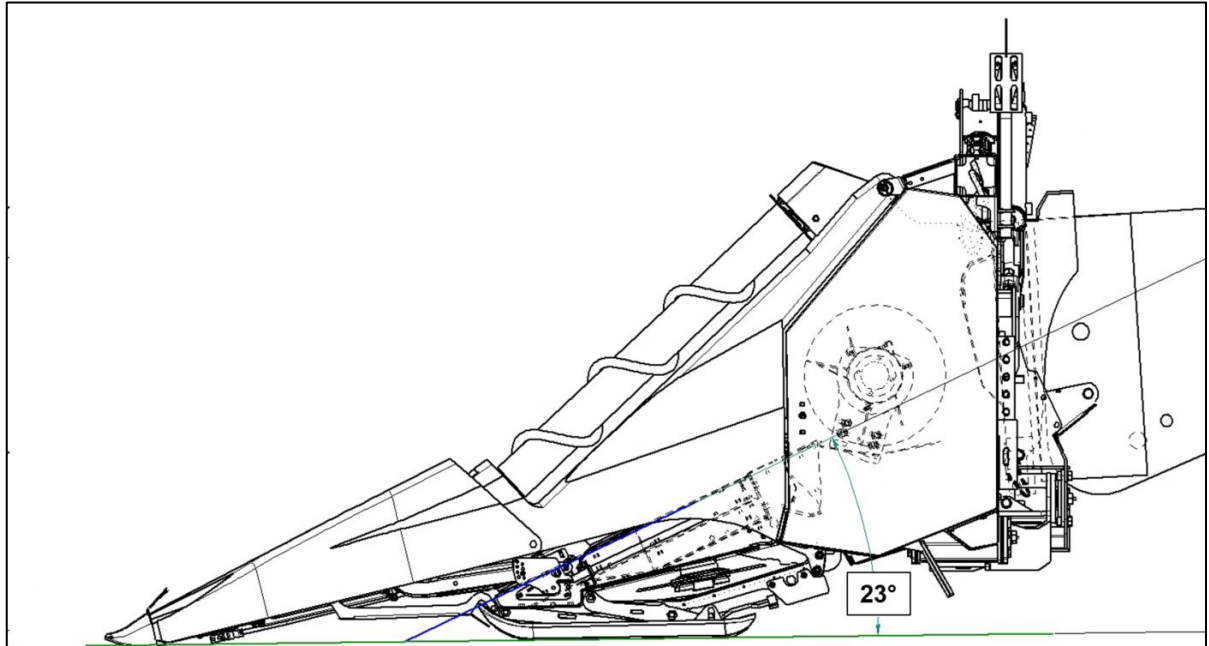

With the header running, lift combine feeder house fully, retract adjustable shoes fully by following steps in section 9.6.e.iv, and lower feederhouse until header is resting on flat, even ground. Turn header off and place an angle measuring tool on a snapping plate of one of the row units and tilt the faceplate of the combine until the snapping plates reach an angle of 23 degrees with respect to the ground.

9.7.2. Plastic snout adjustment

Position the combine and header over a level surface and lower the header until the adjustable skid shoe is just touching the ground. Adjust the snouts following the below instructions until the tip of the snout just touches the ground

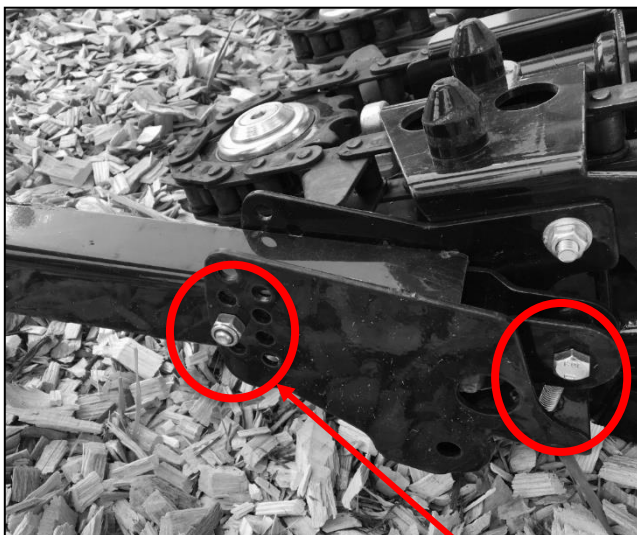

SETUP PROCEDURE AND ADJUSTMENT OF THE CORN HEAD

Coarse adjustment: Move the front cross bolt to move snout a large amount. when tightening, make sure snout support arm is still able to move freely.

Fine adjustment: fine tune snout tip position by adjusting the rear eye bolt to raise or lower the snout so all snouts are just touching the ground.

- Ensure the support adjustment bolt head always faces the gathering chain on the end snouts to avoid contact.
- Fine tune snout adjustment with eye bolt until front of snout just touches the ground.

Manufacturer and Distributor are not responsible for incorrect snout adjustment.

9.8 End Shoe Stalk Deflector Link

To move skid shoe snout into transport, start by removing back pin securement hairpin and L pin.

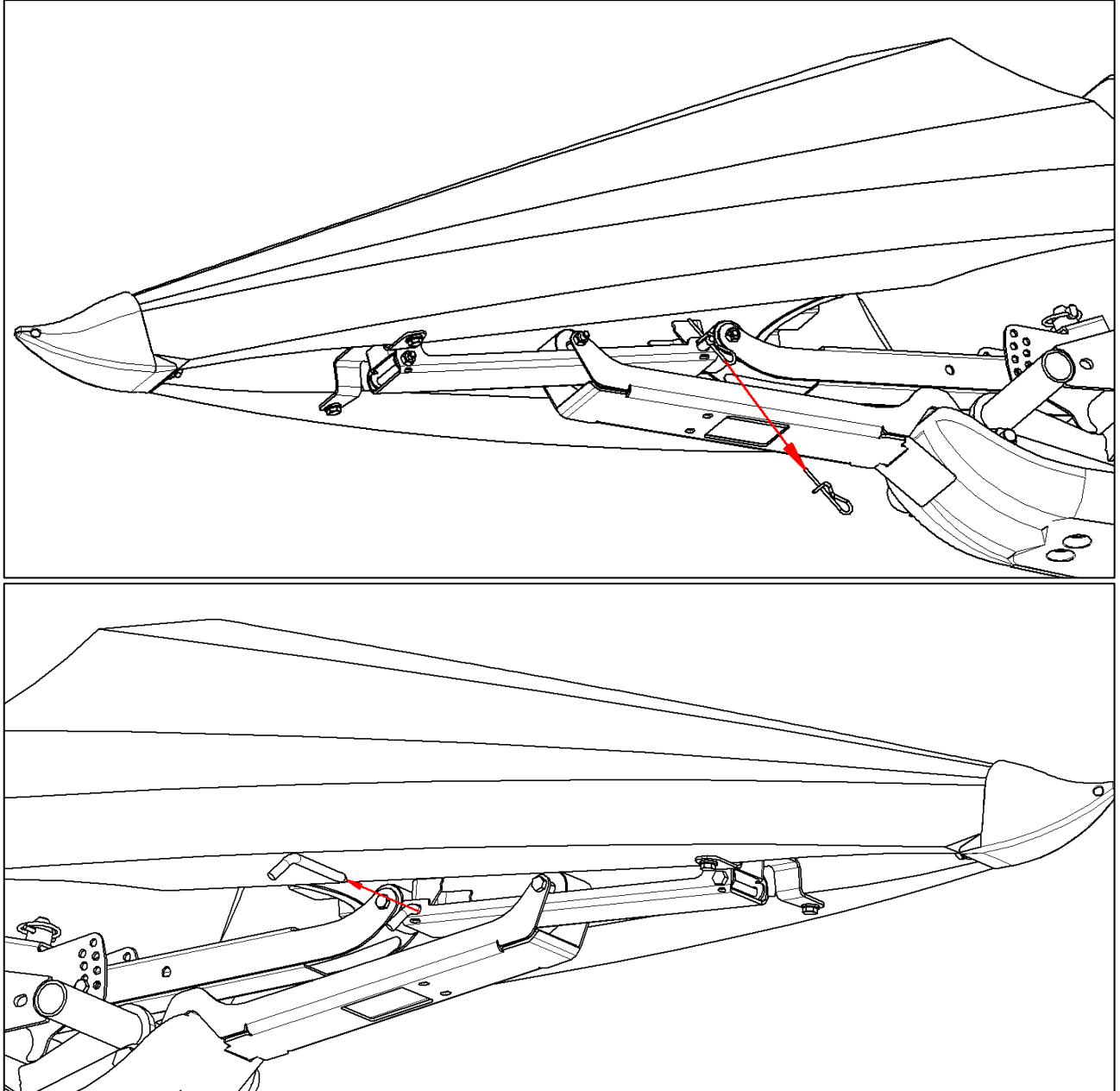

SETUP PROCEDURE AND ADJUSTMENT OF THE CORN HEAD

Push snout upward until slide channel disengages with roller

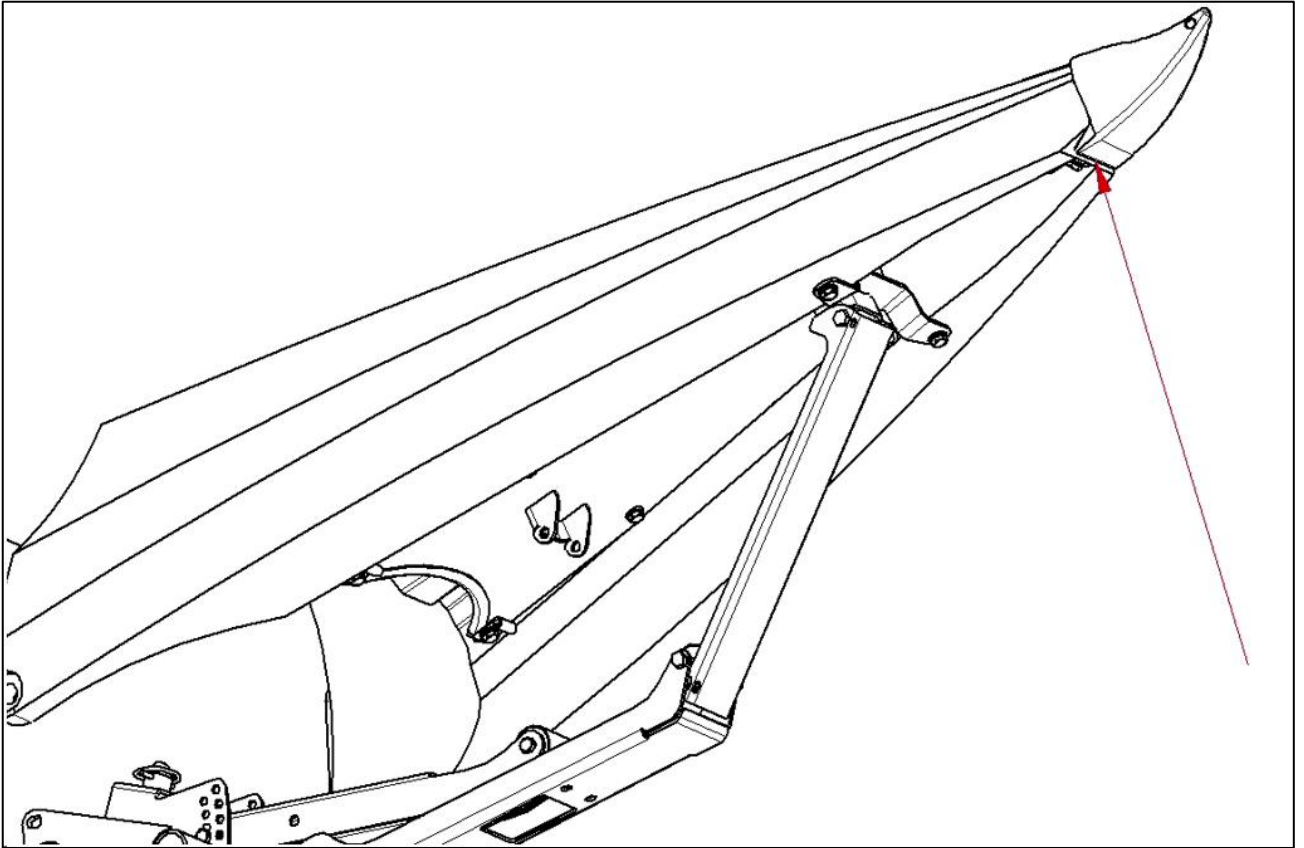

Reinstall slide channel, pin, and hairpin

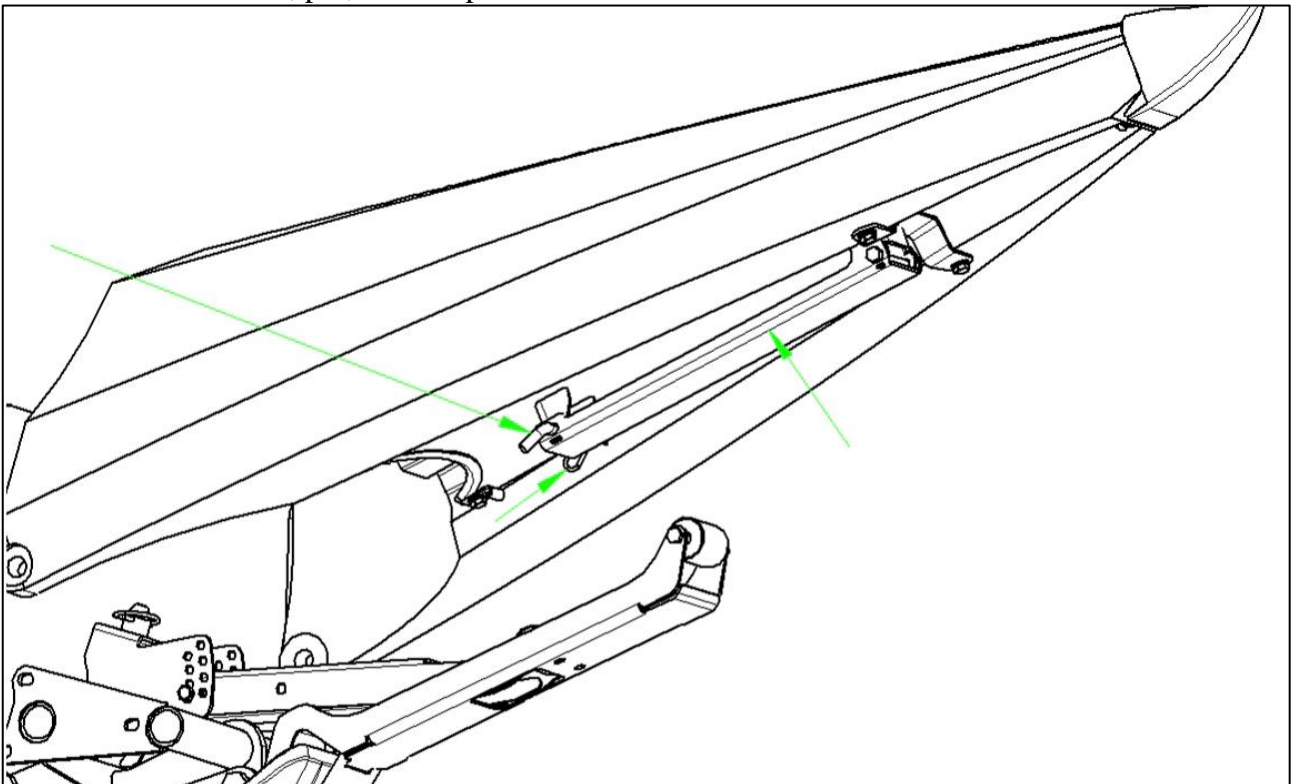

SETUP PROCEDURE AND ADJUSTMENT OF THE CORN HEAD

Place snout tip into snout support, deflector nested into the tip and secure with lynch pin.
Place slide and pins back onto front snout.

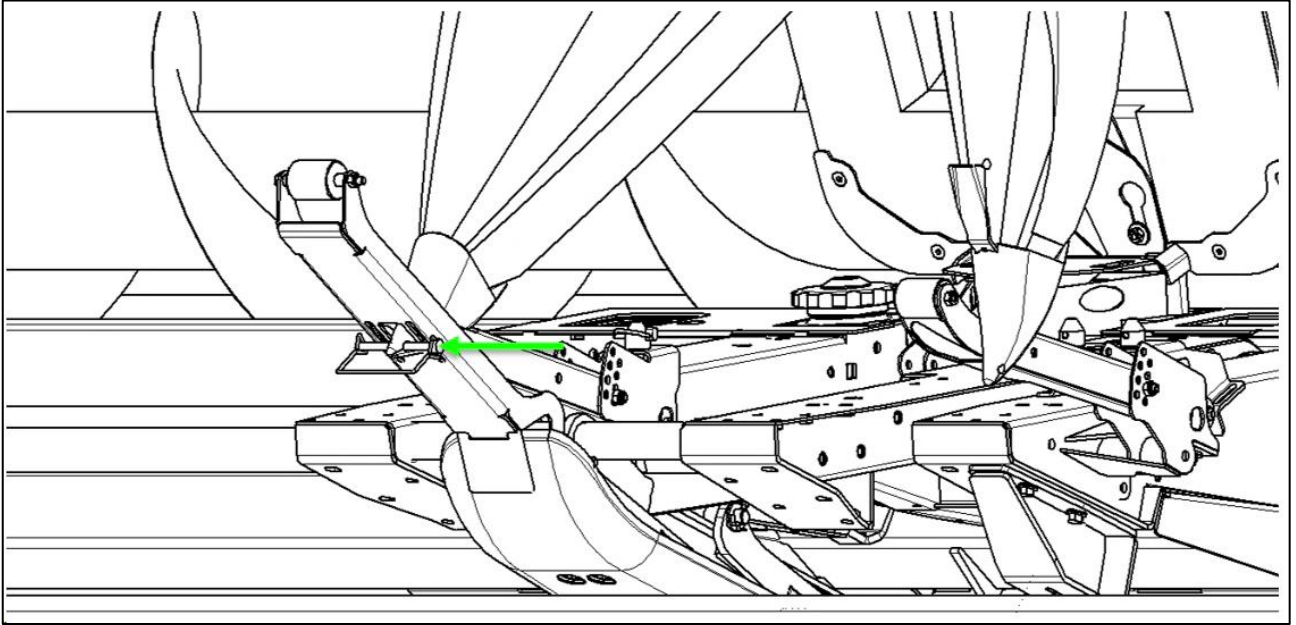

Snout position with a deflector link installed, must be set within the three positions below utilizing eye-bolt to make minor adjustments.

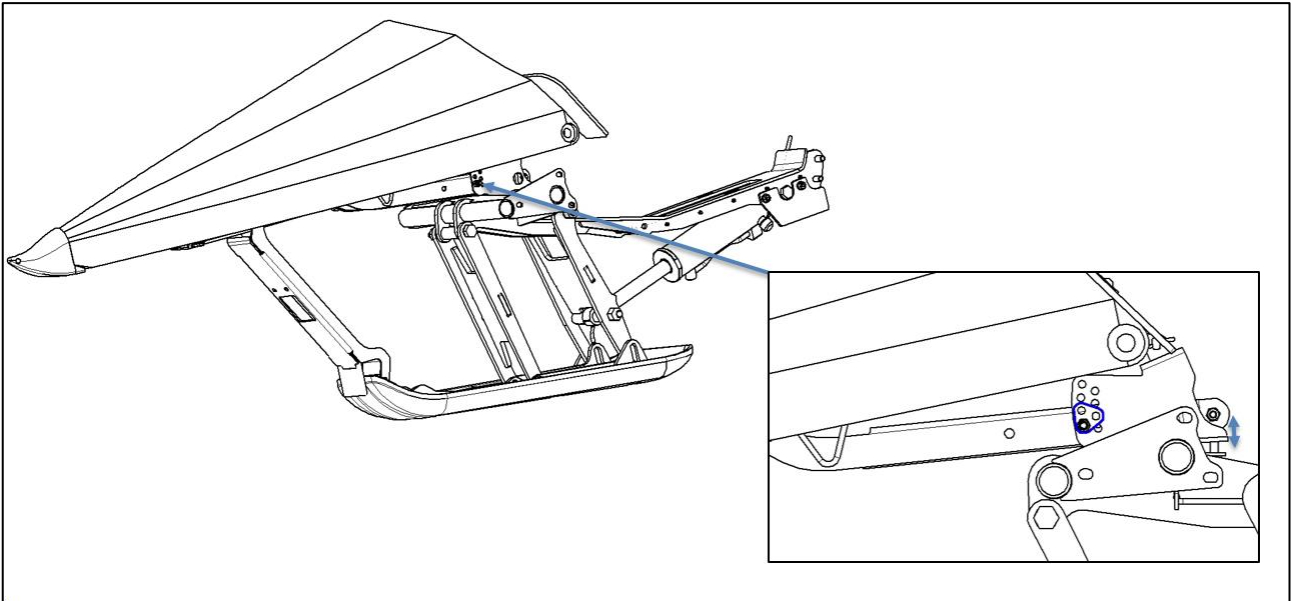

9.9 Installing Lock Link



With header connected to the combine and running, hit 'Rigid' on the control screen. The header will self level and allow for installation of the locking link.

If controls are inoperable or there is an issue with the hydraulic system, the header can be set on the ground and combine faceplate tilt will allow you to bring wings to level. If faceplate tilt is unavailable, place blocks under skid shoes and set header down to flex wings upward.

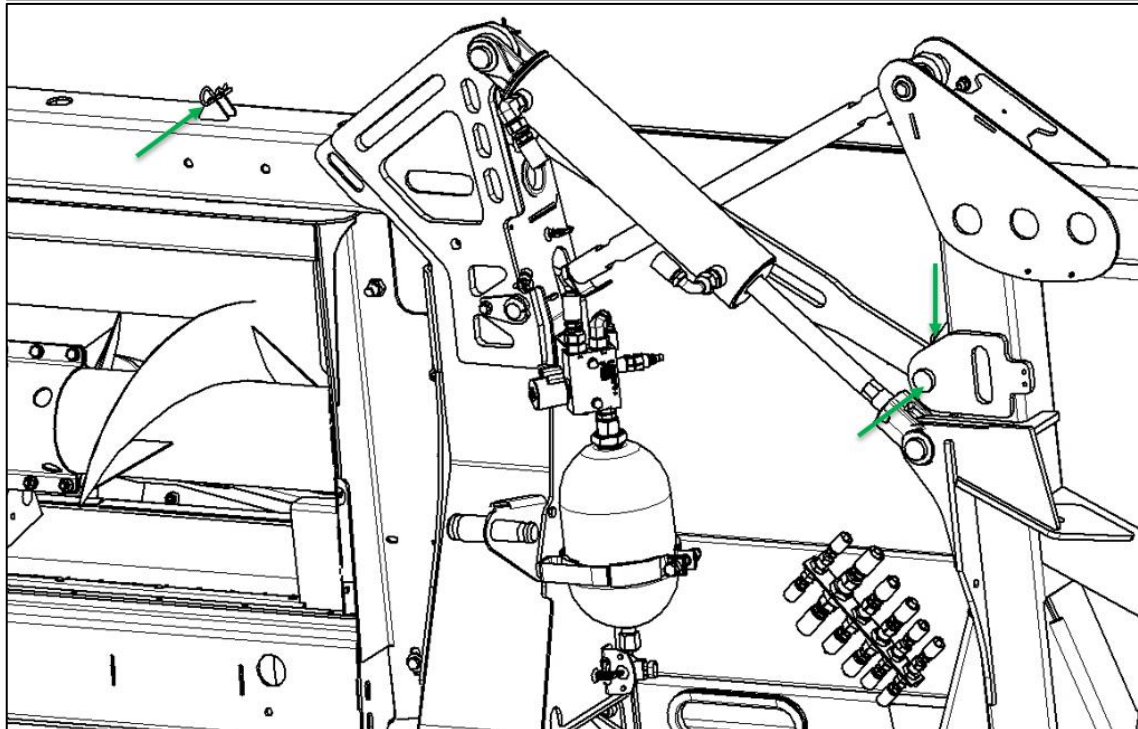
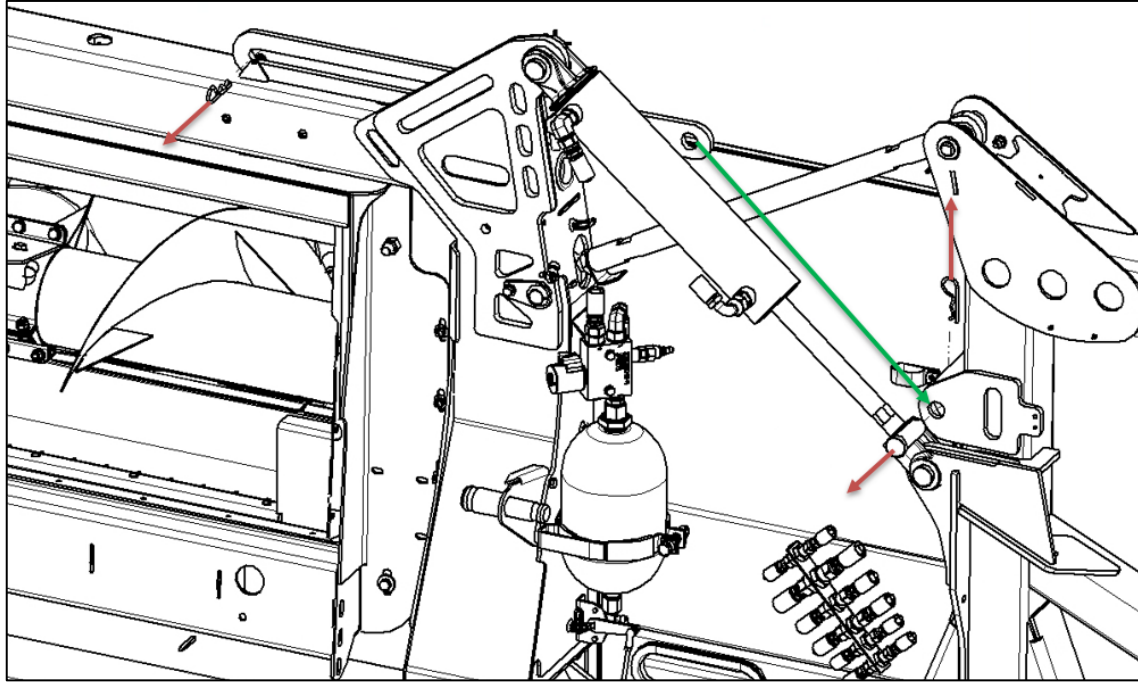

9.10 Removing lock link

With header attached to the combine following procedure 6, turn on power header by engaging the header drive system. Navigate to the "modes" tab and select the "Flex" softkey



on the MacDon FlexCorn control screen. If tension remains on the lock link, set the header on the ground until wings lift to the point where lock links become loose and pins are removable by hand.

Remove locking hair pins and lower lock link securement pin.

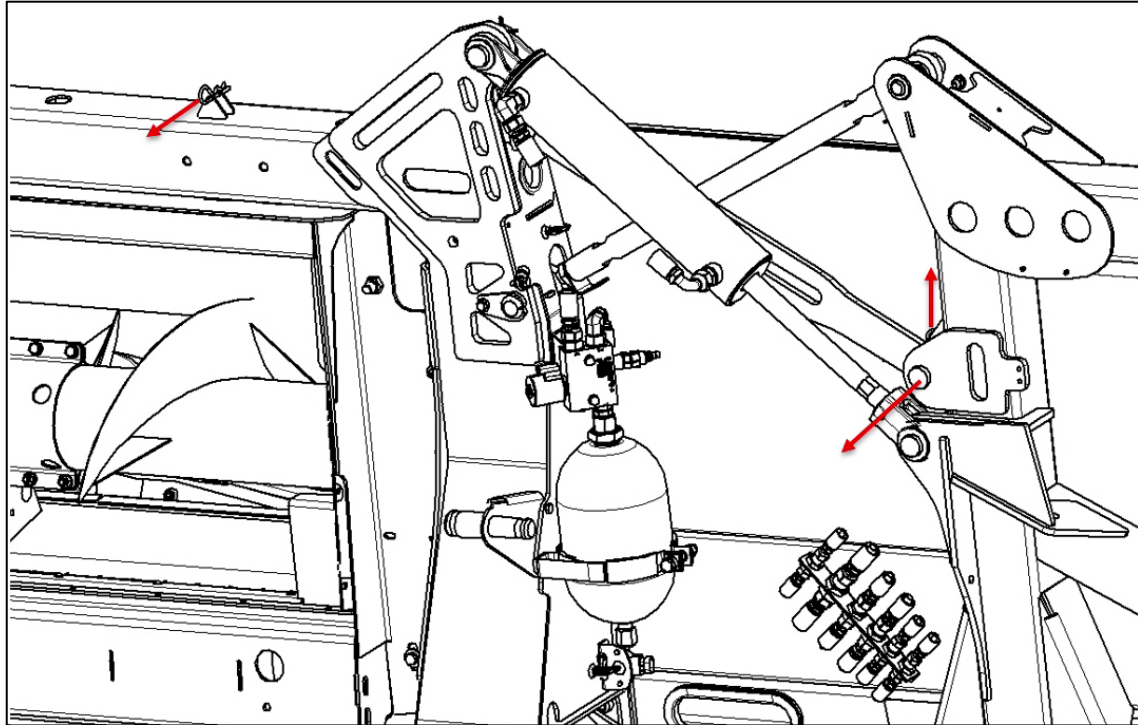

Slide lock link back into the storage position and reinstall lower pin and securement hairpins.

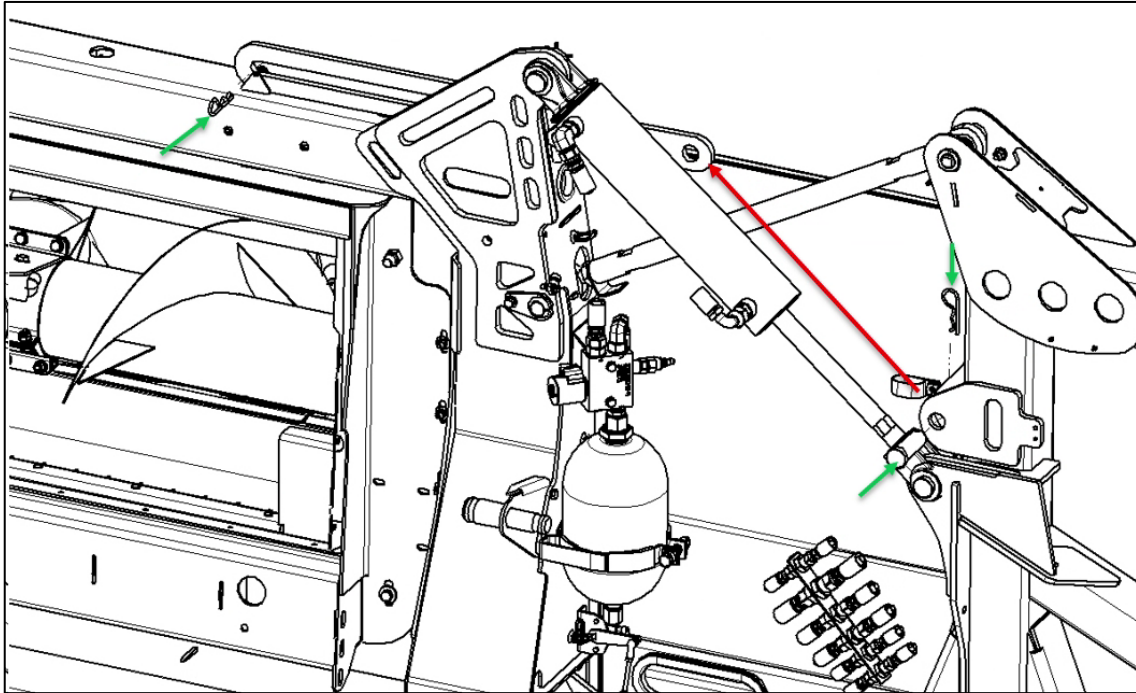

9.11 Transition Seal Adjustment

On FlexCorn headers, the transition seal from the header wings and feederhouse opening should be monitored for proper engagement to prevent crop loss. If seal is not engaged properly, adjust seal by loosening securing bolts and sliding into position that ensures the gap is closed.

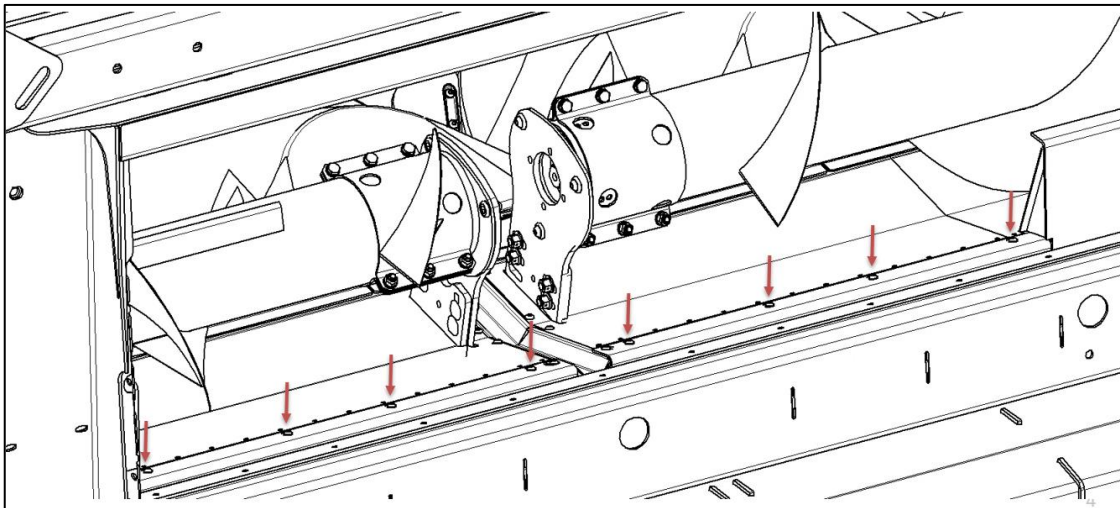

SETUP PROCEDURE AND ADJUSTMENT OF THE CORN HEAD

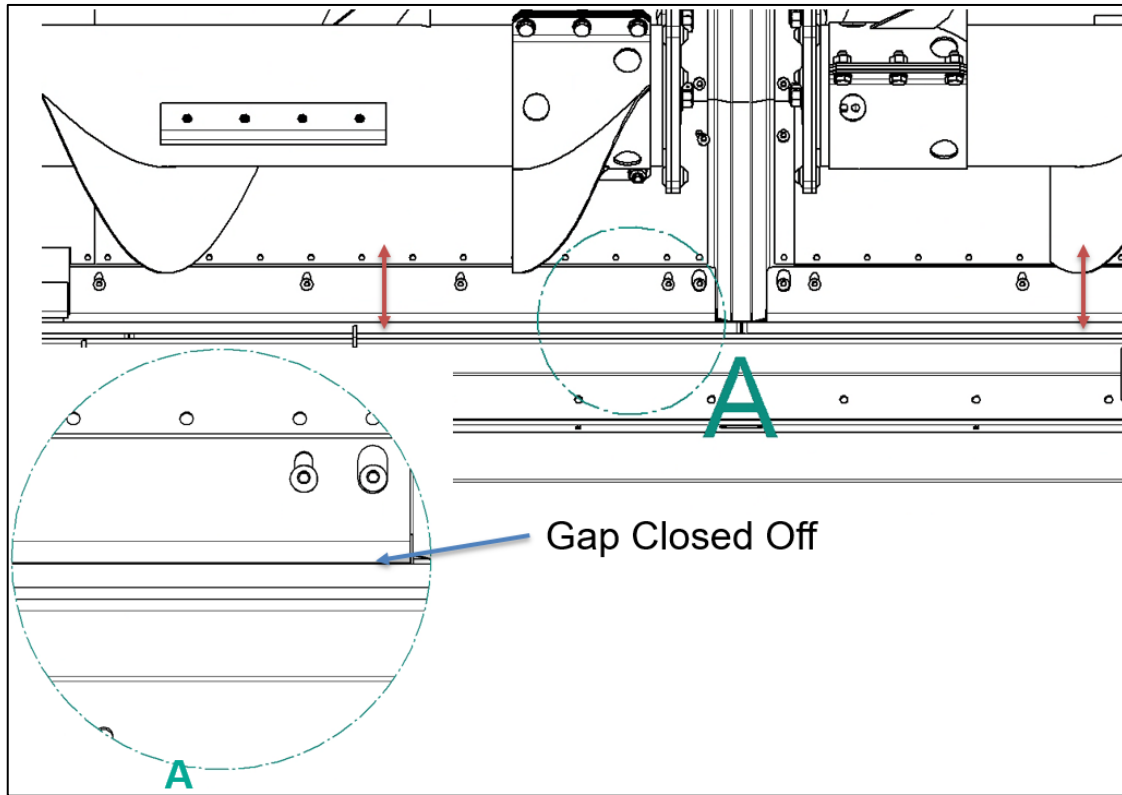

10. HARVESTING

The corn head is ready for harvesting after completing the preceding instructions in this manual, which refer to Mounting, Run-in, and Set-up and Adjustment Procedure.

- Always be aware of the presence of the stalk chopper, if fitted, when harvesting.
- The corn head should be operated only when in harvesting position and in proper working condition.



Specified daily maintenance, correct settings and safe operation are required to ensure that the stalk choppers operate properly and safely. Always consider possible circumstances where the knife can impact stones or other foreign objects laying on the ground. Any such impact can result in pieces separating from the hardened knife blade.

ALWAYS STAY CLEAR of the corn head while in operation. Bystanders should always be at least 30 m (100 ft.) from the corn head while in operation.

1. After 1 hour of initial operation, stop the machine, remove the combine key, and check the following:
 - a. Temperature of all gearboxes (maximum 110 degrees C or 230 F)
 - b. Loose parts or hardware
 - c. Tension of all chains
 - d. General visual inspection

If this inspection reveals any abnormality, determine the cause of the abnormality or contact your dealer for assistance.

10.1. Stalk chopper

The stalk chopper (1) cuts the stalks directly under the snapping rolls (2) with special knives. The stalk chopper drive can be disengaged by turning the hex knob (3) 180 degrees.

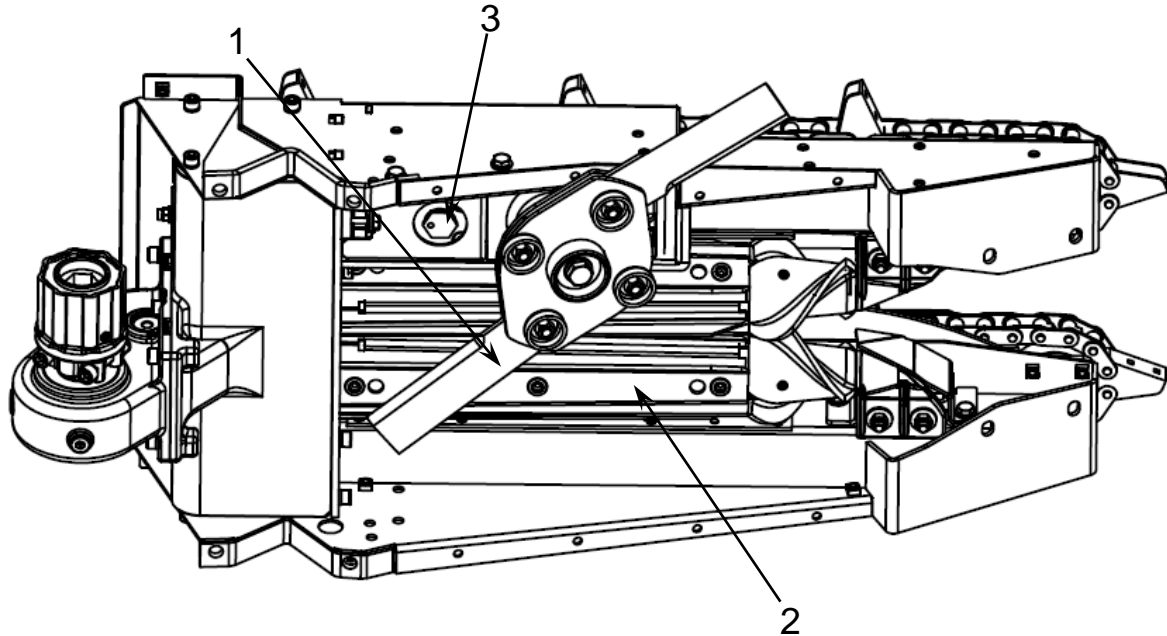

Then chopper knives can be reversed to extend life. When knife replacement is necessary replace the bushings, bolts and nuts. See maintenance section 11.5.2 for more information.

10.2 Snapping Plate Position

The FlexCorn header uses two snapping plate adjustment cylinders to adjust snapping plate position with one cylinder on each wing. The snapping plate cylinders are connected in parallel with hydraulic flow split in the header main manifold so they adjust simultaneously. Occasionally, outside factors can result in left and right side snapping plates having different spacing. Snapping plate setting should be synchronized as needed to ensure consistent operation and minimal crop loss. To re-phase the snapping plates, follow the procedure below:

1. Hold the snapping plate close button until snapping plates on both sides are completely closed
2. Hold the snapping plate open button until snapping plates on both sides are completely open
3. Reset snapping plate spacing to desired setting following steps in section 8.5.2.

10.3 Control System/Operator

1. Help Screens
 - a. Each screen has “Help” information available which includes:
 - i. Options available for that screen
 - ii. Additional information

- b. To display the Help information, select the “Help” softkey on any screen 

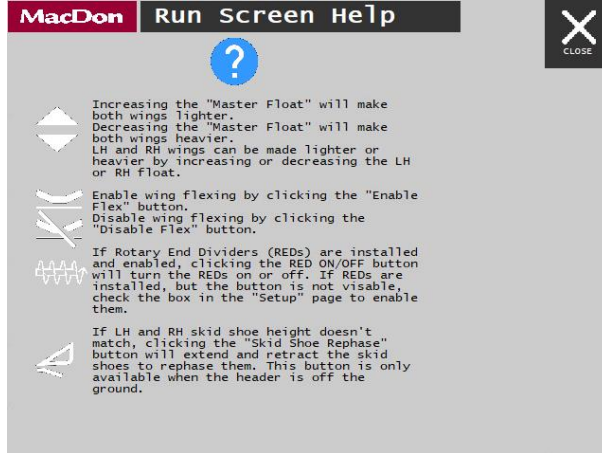

2. Flex Mode:

- a. To operate in flex mode, navigate to the home screen, select the "modes" tab,



and select the "Flex" softkey.

- i. The Flex icon will turn green to indicate the header is in flex mode.



- ii. With the header running, lower the header to the ground so that the AHHC dongles touch the ground.

- iii. The wings will lower from the wing kick position to the ground.

- b. The flex graphic will update during operation. The green lines will move up/down between the limits (white dashed lines) to indicate the current wing



positions (0 to 10)



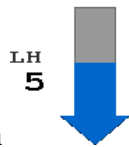

- c. Adjust the combine AHHC to set the header to the desired cut height. The skid shoes will automatically move to this position when header is in harvesting position.

- d. The current Ground pressure setting is indicated by the blue/gray bar graph on each side of the flex graphic as well as the percentage in the center of the bar



graph

- i. It is recommended to start with a Ground pressure setting of 5 and increase/decrease the setting based on performance and current conditions.
- e. If the skid shoes begin to dig into the ground or push soil, Ground pressure should be reduced.

- i. To reduce the ground pressure (reduce weight on skid shoes) use the LH/RH Ground pressure or master ground pressure decrease buttons: 
 - f. If the wings are slow to respond or skid shoes fail do not stay engaged with the ground, ground pressure should be increased.
 - i. To increase the ground pressure (increase the weight on skid shoes) use the LH/RH Ground pressure or master ground pressure increase buttons: 
 - g. The “Master ground pressure” buttons increase/decrease both wings ground pressure simultaneously.
 - h. The “LH/RH ground pressure” buttons increase/decrease each wings ground pressure independently.
- 3. Rigid Mode:
 - a. With the header running, select the “Rigid” button on the Mode tab of the main run screen to switch to rigid mode 
 - b. The rigid mode icon in the top banner will flash to indicate the header is entering rigid mode.
 - c. The wings will self-level and lock into position. The rigid icon in the top banner will be solid and the rigid icon in the mode tab will change to green to show the process is complete.
- 4. Switching Rotary End Dividers (REDs) ON/OFF
 - a. If REDs are installed, ensure they are enabled in the Setup screen
 - b. If installed, REDs can be switched on and off by selecting the RED ON/OFF button on the Main Run screen 
 - i. This button is a “latching” button so it will change states between on and off each time it is selected
- 5. Setting header cut height.
 - a. The FlexCorn system works with the combine Automatic Header Height Control (AHHC) system to maintain a uniform cut height while harvesting.
 - b. This is achieved by sending the appropriate voltage signals to the combine which are interpreted by the combine to automatically control the feederhouse height and lateral tilt, if available
 - c. The FlexCorn system also automatically adjusts the adjustable skid shoes on the header to match the cut height at the ends of the header to the height at the center.
 - d. To adjust cut height, adjust the combine AHHC setting in the cab.
 - e. If cut height appears uneven:
 - i. Ensure sure AHHC dongles on the header are not stuck or damaged.
 - ii. Ensure header and combine AHHC systems have been calibrated.
 - iii. Rephase skid shoe cylinders by following the procedure listed in section 9.3.6.
- 6. Rephasing Skid Shoes

- a. The skid shoes are adjusted hydraulically in series via a master/slave hydraulic circuit
- b. Due to outside factors or overloading scenarios, the skid shoes can become out of phase
- c. The skid shoe adjustment cylinders can be rephased by extending them fully to allow fluid to flow from one cylinder to the next
- d. If “Automatic Skid Shoe Rephasing” is selected in the Setup screen, this rephasing will occur automatically when the header is lifted off the ground if necessary
- e. If “Automatic Skid Shoe Rephasing” is not selected in the Setup screen, the skid shoes may need to be rephased manually from time to time
 - i. If skid shoes are significantly out-of-phase, an alarm will appear on the screen to alert the operator that rephasing is advised
 - ii. The “Skid Adjust” buttons will appear on the screen any time the



header is lifted off the ground

- iii. Pressing and holding the skid extend button for 10 seconds will



extend the skid shoes to rephase them

- iv. Press and hold skid retract button for 10 seconds to bring back to



highest position.

- v. When the header is lowered back to the ground, the skid shoes will continue to adjust automatically
- f. If skid shoes cannot fully retract due to debris:
 - i. Lift the header off the ground and raise it fully.
 - ii. Select the rigid mode from the Mode tab of the main screen, allow the header to level and lock.



- iii. The “Skid Adjust” buttons will appear on the screen

- iv. Extend the shoes by pressing and holding the skid extend button for 10



seconds

- v. Turn the header and combine off, remove the key from the ignition, engage the feederhouse safety props, and install the header lock links to prevent the wings from dropping.
- vi. Remove debris.
- vii. Once debris is removed, uninstall header lock links and resume operation.

7. Service Mode

- a. If the header needs to be serviced with the header mounted on the combine and hydraulics connected:
 - i. Ensure the header hydraulic multicoupler is connected to the combine.
 - ii. Either support the header wings on the ground or install the lock links
 - iii. Select the “Diagnostics” softkey to navigate to the Diagnostics screen



- iv. Select the “Service” softkey



- v. An alarm will appear to alert the operator that the wings will drop if not properly supported.

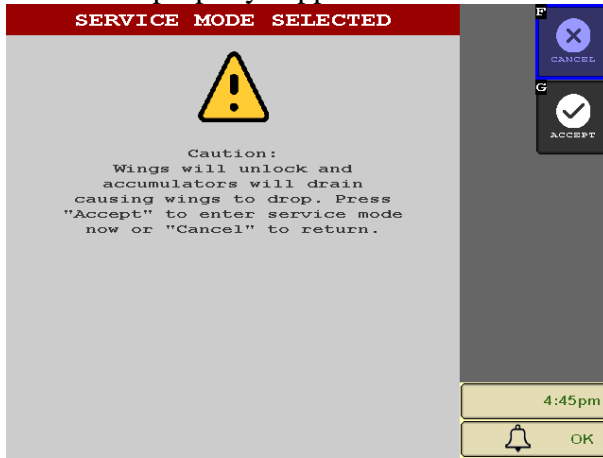

1. Select the “Accept” softkey to enter Service Mode
2. Select the “Cancel” softkey to return to the previous screen



without entering Service Mode



- vi. After pushing accept, the wings will unlock and all hydraulic fluid from the accumulators will drain back to the combine through the hydraulic reel drive return line.
- vii. The “Service” icon will be displayed in place of the “lock” icons on

the Run screen 

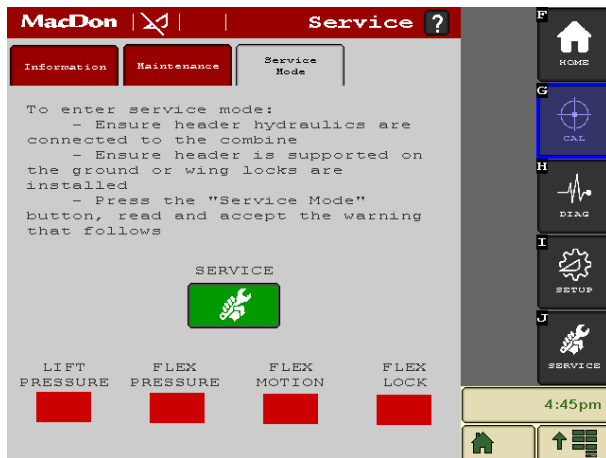

- viii. To exit Service Mode, select either the “Enable Flex” or “Disable Flex” buttons on the Run Screen
- b. If the header needs to be serviced with the header disconnected from the combine:

WARNING: Draining the system in this way does not depressurize the flex cylinders so care should be taken not to loosen any connections on the flex cylinders or lift accumulator manifolds (MD# 349213) and ensure the wings remain supported. It is recommended to follow the procedure for servicing the header with it mounted on a combine as described in 7.a above.

- i. Support the header wings on the ground
- ii. Slowly crack the reel drive circuit return hose fitting at the combine multi-coupler (See combine multicoupler diagram), but do not fully disconnect fitting.

WARNING: this hose will contain a small amount of pressurized fluid.

Note: Before reassembly, the fitting o ring will need to be inspected for damage and fitting properly retorqued.

- iii. Place oil pan beneath loosened fitting
- iv. Locate the three manual override valves on the FlexCorn main hydraulic manifold labelled: SF1, SF2, and SV3

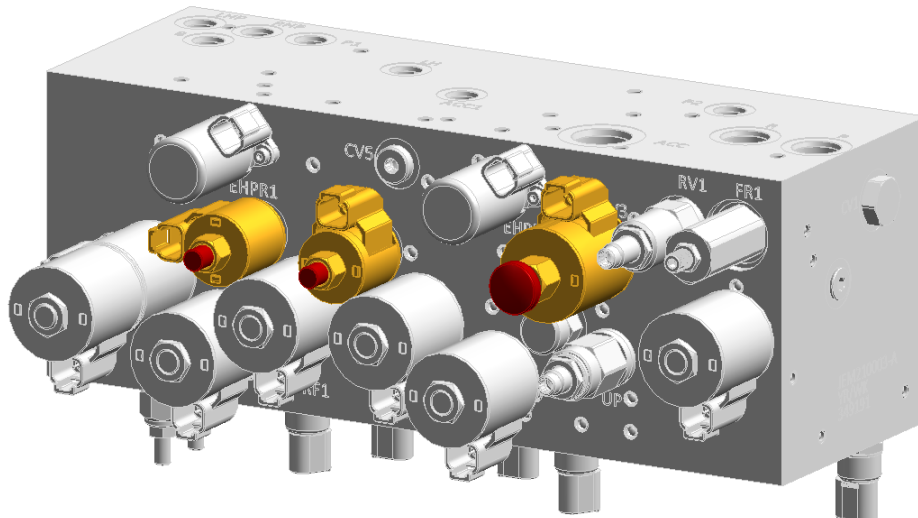

- v. Slowly press each of the valve overrides one-by-one to allow all hydraulic fluid from the accumulators to drain through the hydraulic reel drive return line.
- vi. Once all three valves have been used to drain the system completely, the system can be serviced.

11. MOUNTING TO ANOTHER TYPE OF COMBINE

The mounting kits for various combines are shown in the parts manual. Order the relevant mounting kit from your dealer.

FlexCorn header is currently limited to certain combine brands

- CaseIH
- John Deere
- New Holland (Model Year 2009 and later)



When mounting the corn head to another type of combine always use all of the protective shields. Ensure that the lower latch attachment and drive connections are secure.

12. MAINTENANCE AND LUBRICATION

12.1. Auger

Lubricate and check chain tension every 50 hours. Chain tension should be set so the deflection is 19mm (0.75") at position A

Clean debris under shielding every 50 hours!

Loosen torx bolt holding tensioner pulley (B) then adjust draw bolt (C) to achieve correct chain tension then retighten tensioner sprocket bolt.

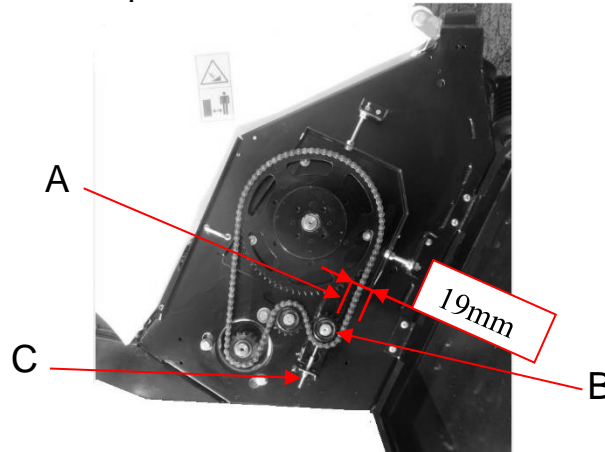

12.2. Drive Gearboxes

SAE 80W-140 oil (0.9l) is used for lubrication; SAE 85W-140 can be used as alternative. To check the oil level, remove the level plug (1) with the corn head in harvesting position. drive and driven gearboxes should receive a break in oil change at 50 hours. Oil should be changed every 250 hours thereafter. Oil level should be checked at least annually.

Oil level should be checked with the header in harvesting position. Correct oil level is achieved when oil just drips out when the level plug (1) is removed.

The drain plug (3) and breather (2) are on the main casting of the gearbox. Filling the oil through either a level plug or the breather port.

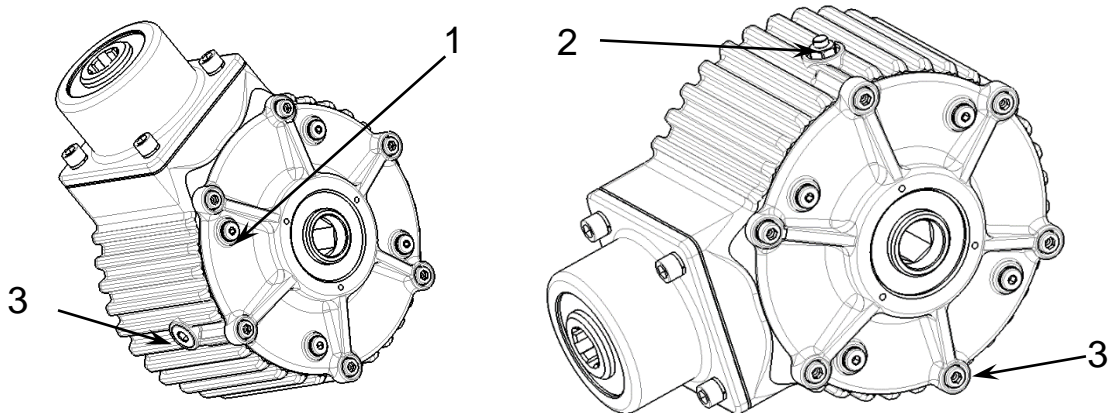

Location of the oil checking bolts on the gearbox.

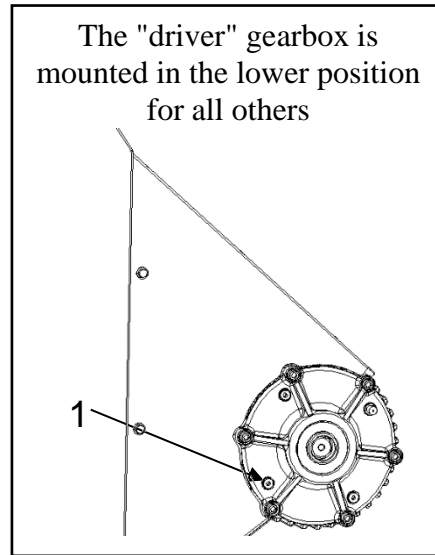
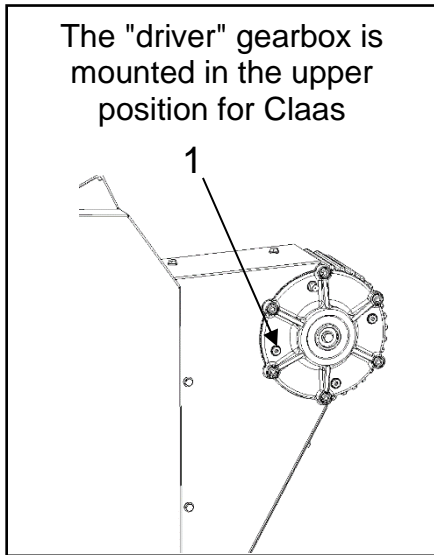

Note: The location of the breather depends on the final position of the gearbox. Breather should always be mounted on the top of the gearbox as shown.

12.4. Drive components

12.4.1. U-joint shafts:

- The U-joints should be greased every 100 hours.
- Grease the sliding surfaces of the U-joint shafts and cross shafts every 100 hours.

12.4.2. Chain couplings, Slip clutches

- Grease the Chain couplings every 250 hours
- Grease the Slip clutches every 250 hours

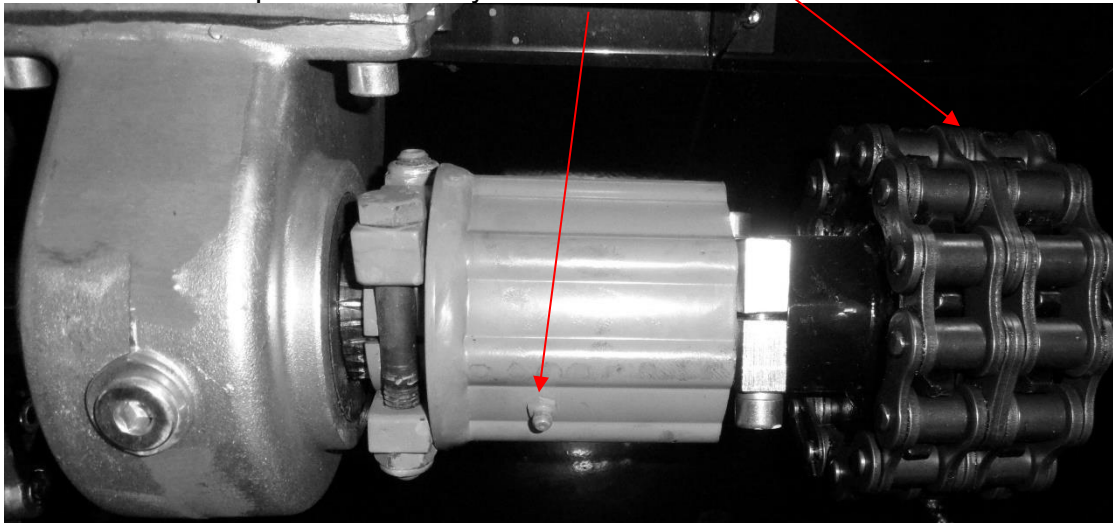

12.5. Snapping unit

12.5.1. Gearboxes

	Snapping unit gearbox	Chopper gearbox (if equipped)
SAE 80W-140 oil SAE 85W-140 can be used as alternative	-	0.26 kg (0.3 l)
EP-00 liquid grease	2.5 kg (2.5 l)	-
Check frequency	Annually or every 250 hours whichever comes first	50 hours
Break-in period	Not Required	50 hours after first usage
Change interval	-	250 hours

Inspect gearboxes daily to detect any leakage which may cause failure.

Snapping unit main gearbox:

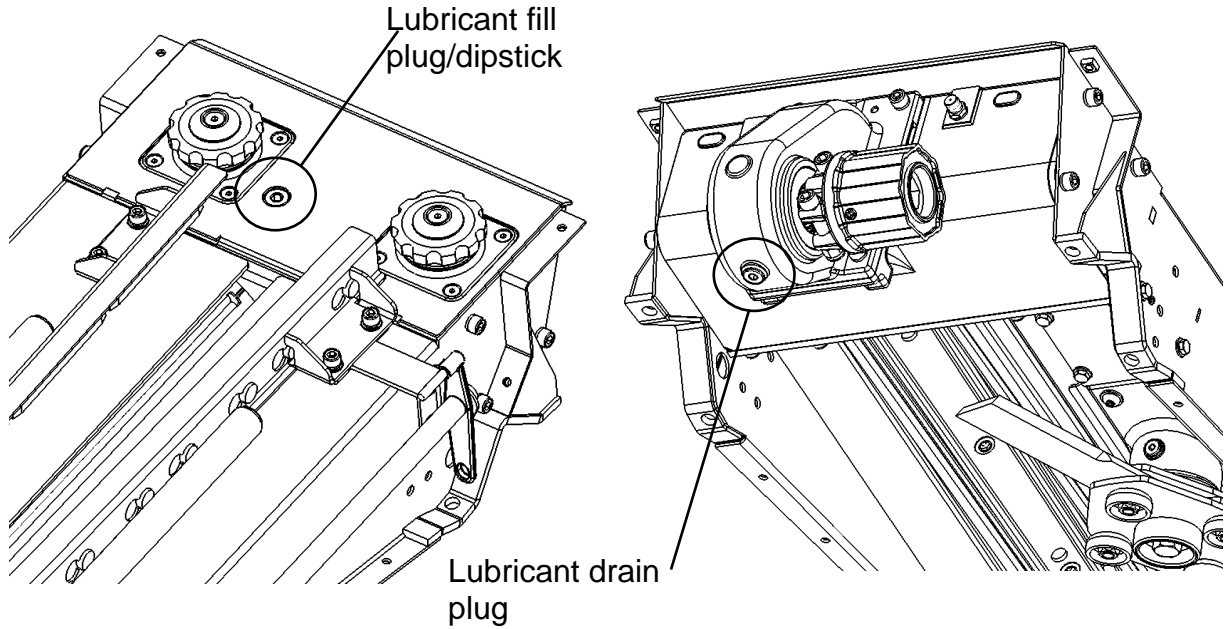

Stalk chopper gearbox:

Lubricant fill
plug/dipstick

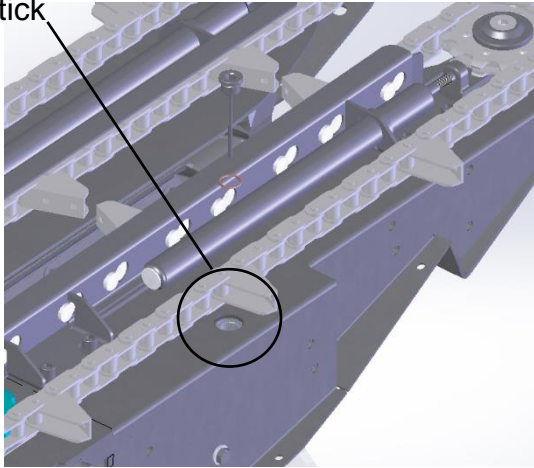

Lubricant drain

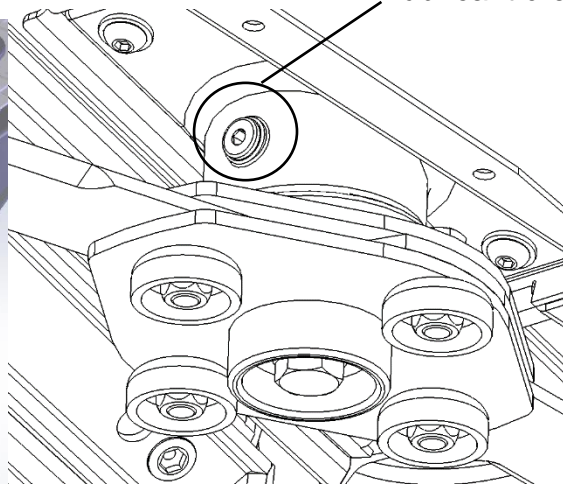

To check lubricant levels:

- Lower corn head to the ground
- Unscrew the dipstick
- Wipe the dipstick, then replace it but do not screw it back in
- Wait, then remove the dipstick
- The lubricant level should be midway between the minimum and maximum warning lines.

Lubricant fill plug/
dipstick

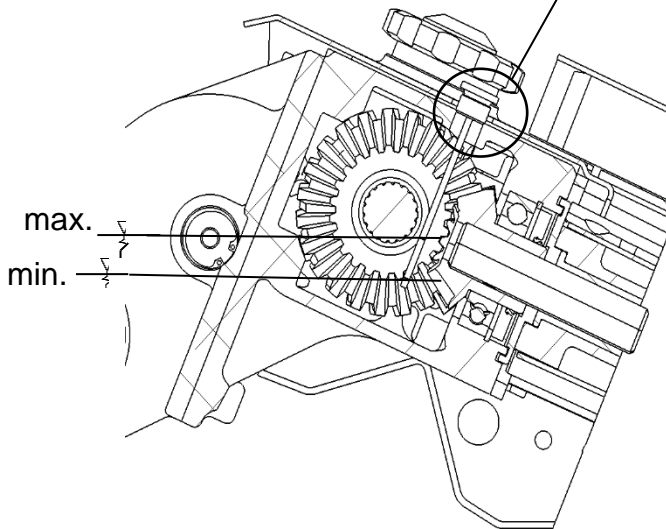

Snapping unit main gearbox

Lubricant fill plug/
dipstick

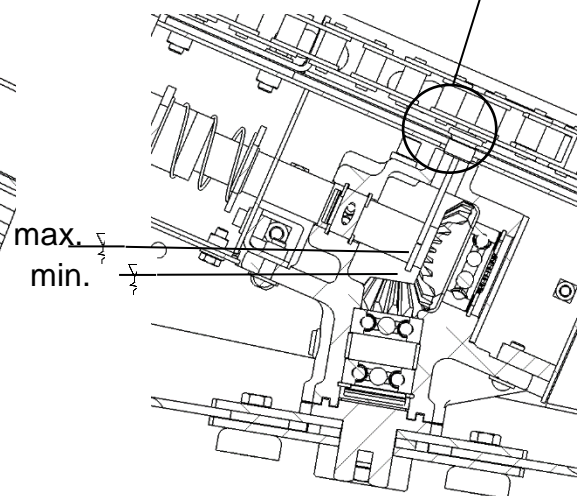

Chopper gearbox

12.5.2 Chopper knives

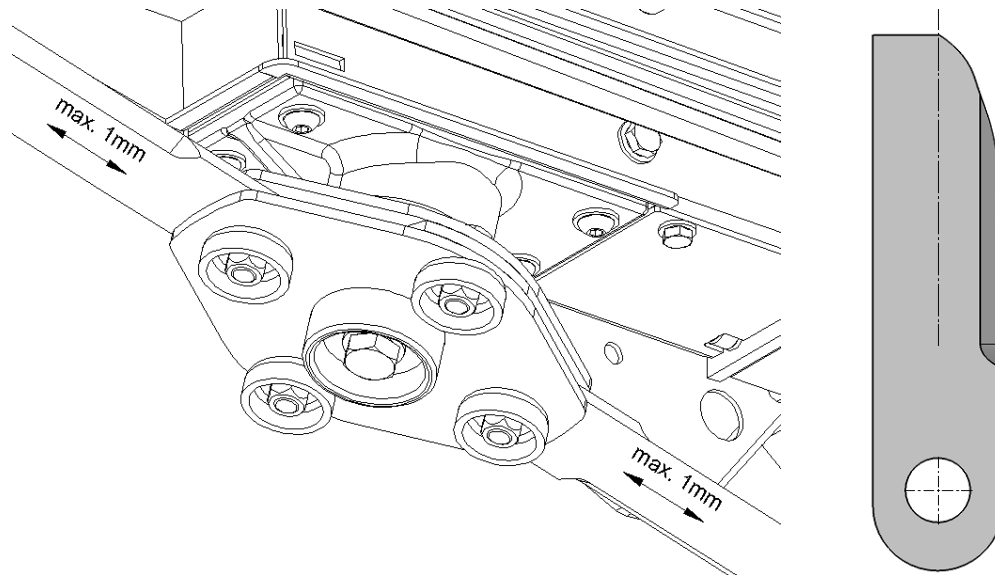

The chopper knives can be reversed when worn. When knife replacement is necessary replace the bushings, bolts, and nuts. Blade should be replaced before wear reaches the centerline of the blade, or when chopping performance is degraded.



- Check knife condition daily.
- Never operate with damaged knives.
- The radial clearance between the knife and bushing should not exceed 1 mm (.04"). If clearance exceeds 1 mm (.04"), change both the knife, bushing, bolt, and nut.
- Knives must be changed only in pairs because of the high rotational speed and balance requirements.
- The knife support bolts should be checked daily and kept tight.

Neither the Manufacturer nor Distributor assumes any responsibility for wear or failure resulting from improper maintenance or lubrication.

12.5.3. Snapping roll

The front bearings are lubricated with EP NLGI Grade 2 and sealed on both sides by the bearing manufacturer. A greased labyrinth is provided to protect the bearings. Grease the front fitting every 100 operating hours until grease extrudes from the labyrinth. This will ensure flushing of the old grease and fully replacing it with new grease.

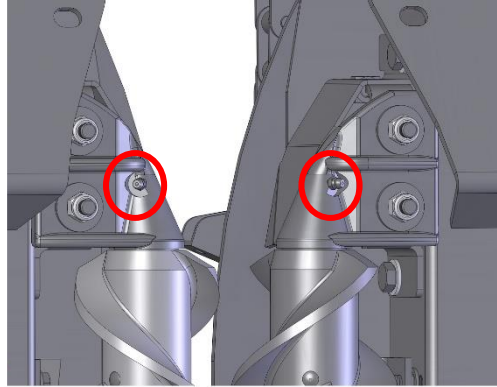

The locations of the front grease fitting of the snapping roll

Ensure that the snapping roll knife retaining bolts are kept tight at all times, Torque nuts to 45 Nm (33 lbf•ft).

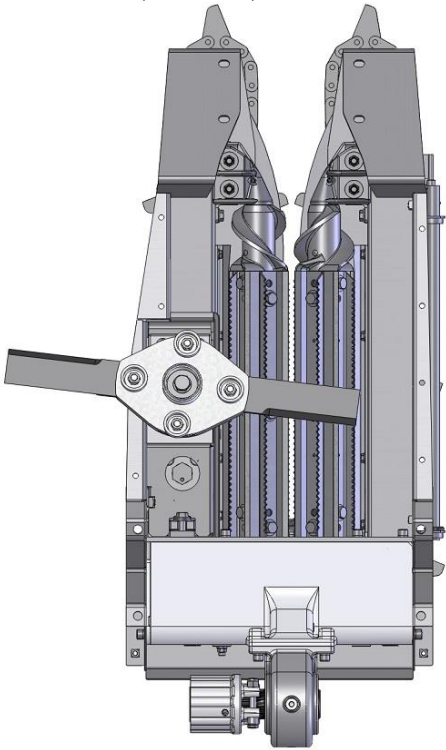

- Check the clearance between snapping rolls knife edges
- Factory setting 1 mm (0.04")
- **Note:** In very dry conditions, a snapping roll gap of 3-4mm may be beneficial to feeding performance. When adjusting snapping roll gap always check vine knife adjustment

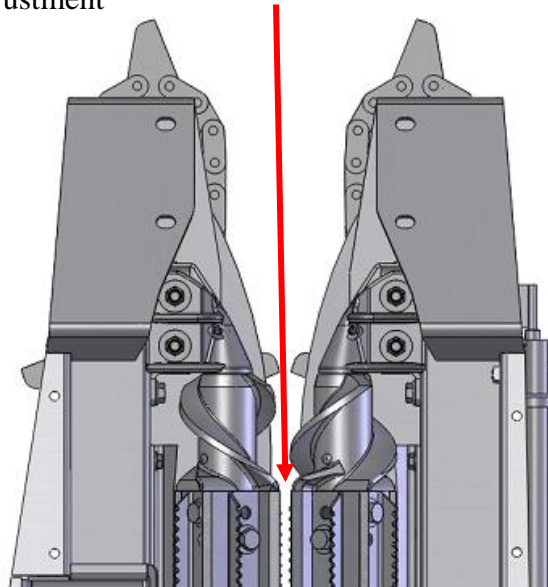

12.5.4. Gathering chain

- Lubricate chains at the end of the season to prevent corrosion.
- Check every 10 hours for abnormal wear.

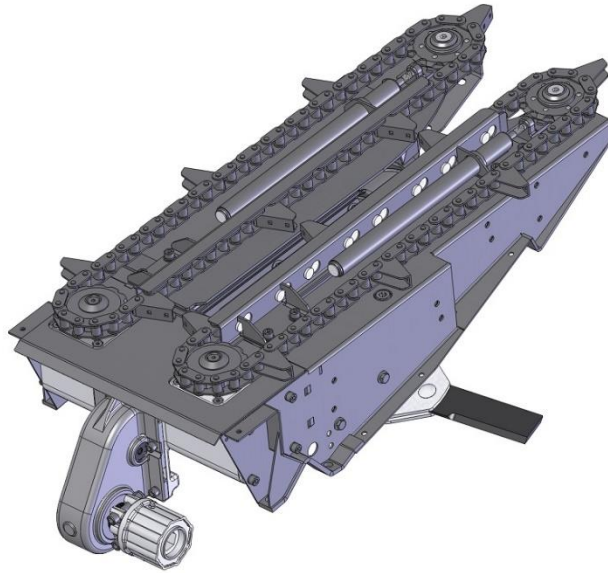

12.5.5. Snapping plate cable

Lubricate the top of the snapping plate cable annually with chain or cable lubricant to prevent the cable from seizing.

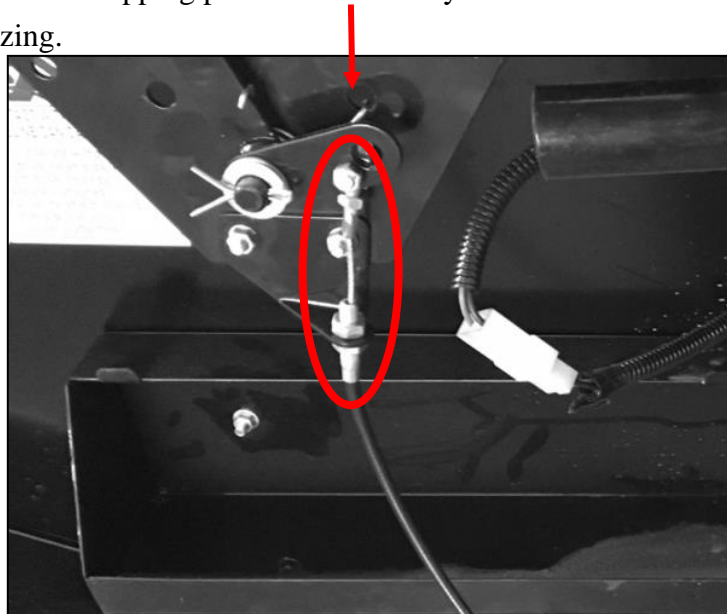

12.6 Lower Links

- Grease pivot points every 50 hours

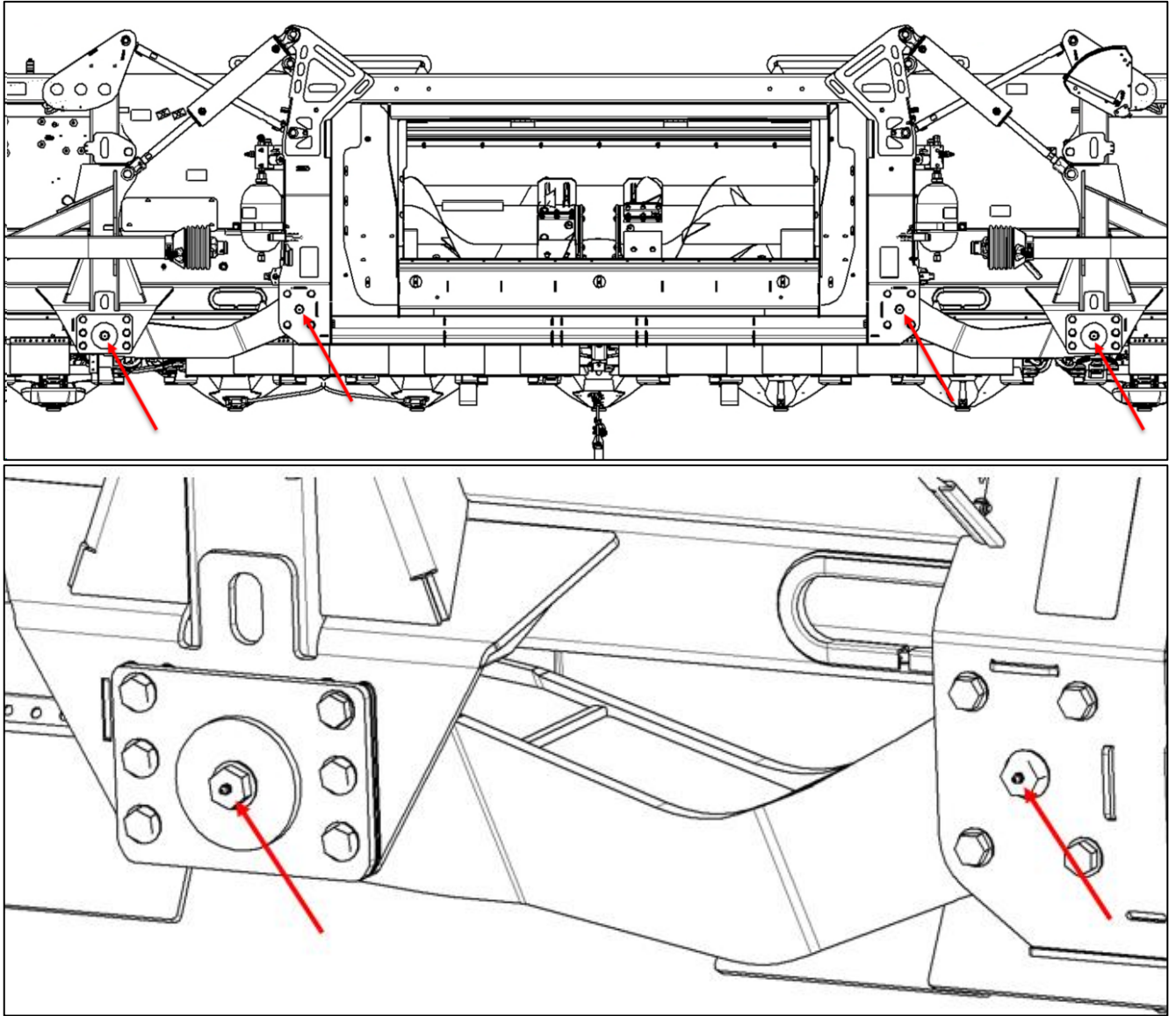

12.7 Accumulator Charge Pressure (Check Annually)

- Run a header calibration following the procedure in section 6. (Control system setup).8
- With a successful calibration, lift accumulator gas pressure will be provided as shown.

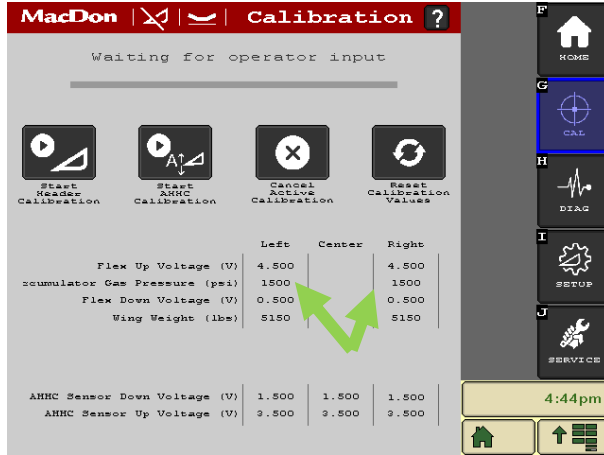

- Make sure pressure is within the following range:

Header Model	Lift Accumulator Pressure
FC3012/FC3012C	850-950 psi
FC3016/FC3016C	1450-1550 psi

- If pressure is outside this range, contact your dealer to adjust the accumulator gas pressure.

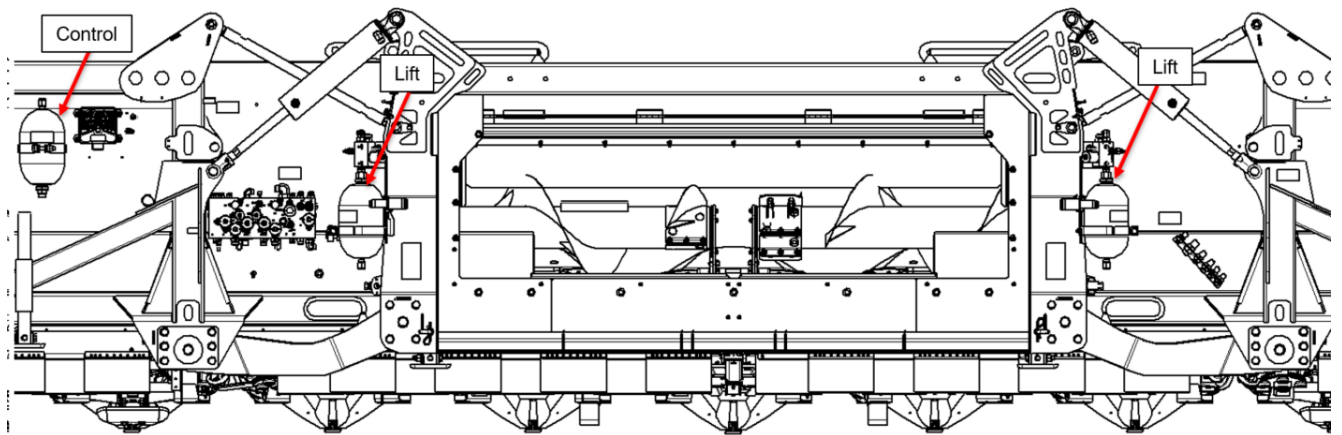

13.2. Sensors 1

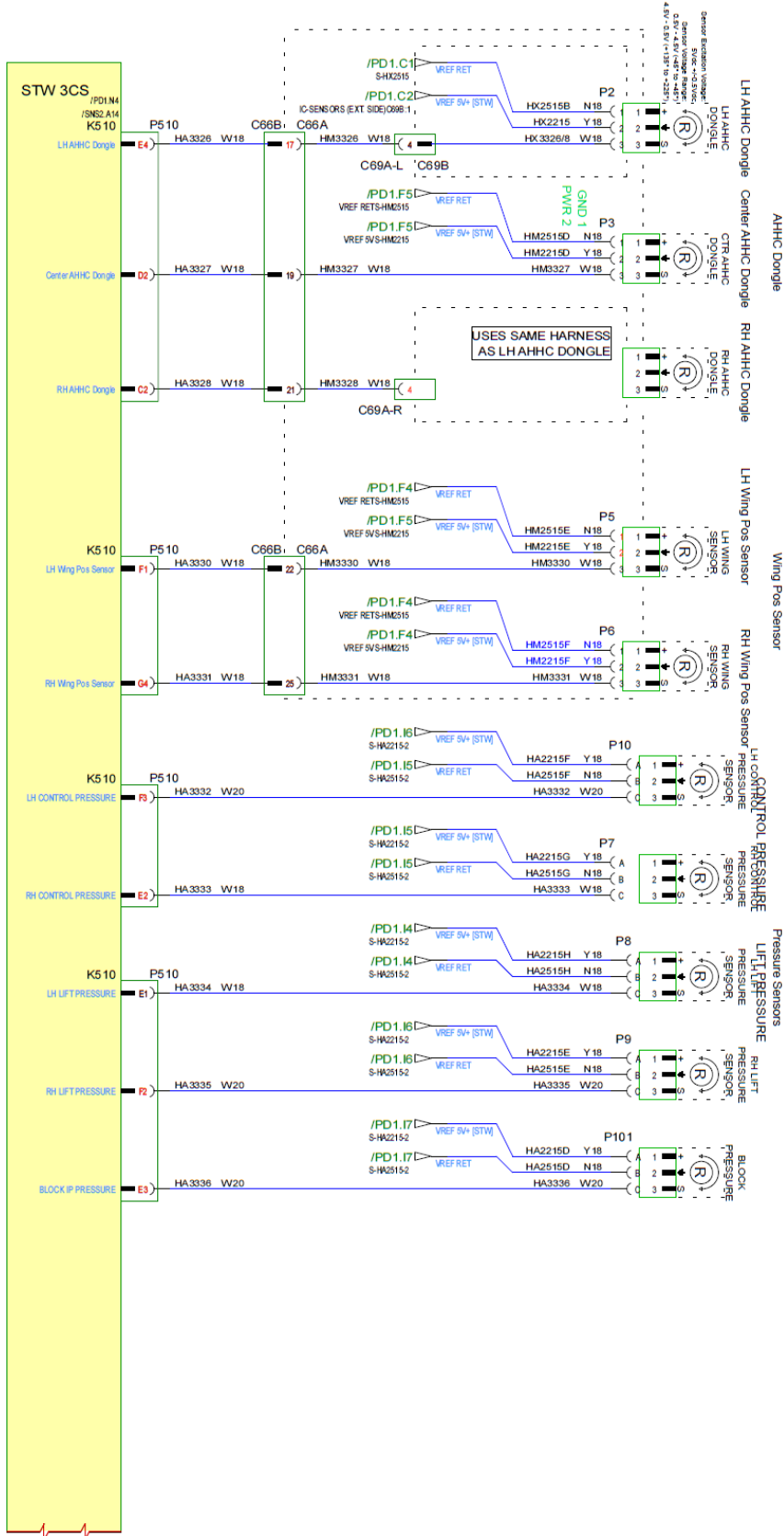

13.3. Sensors 2

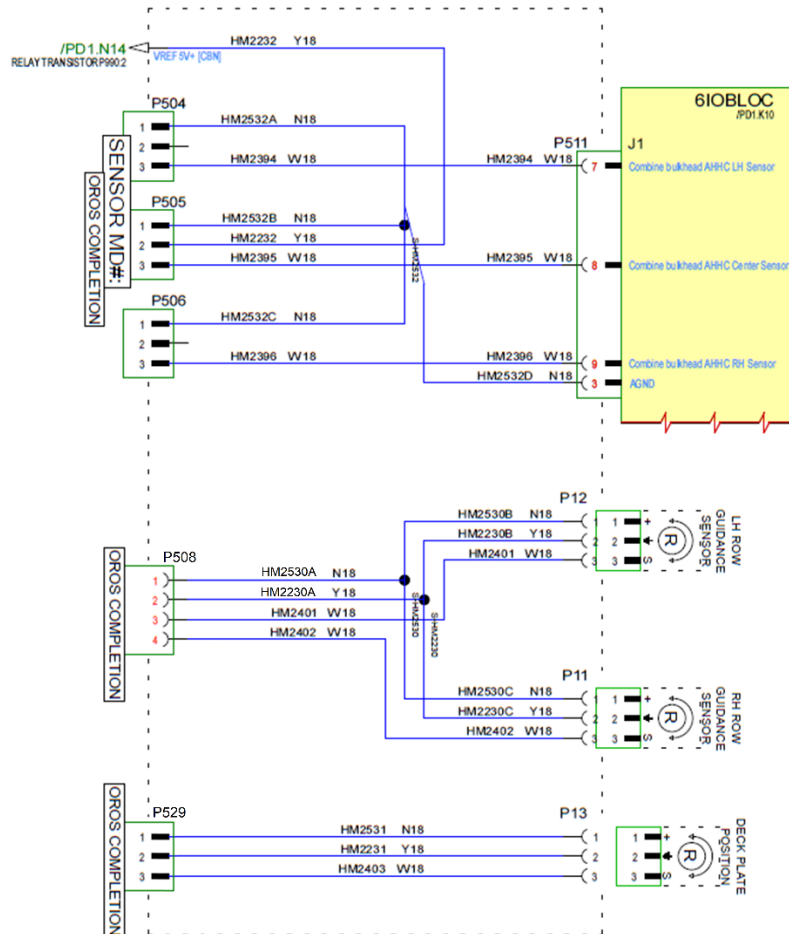
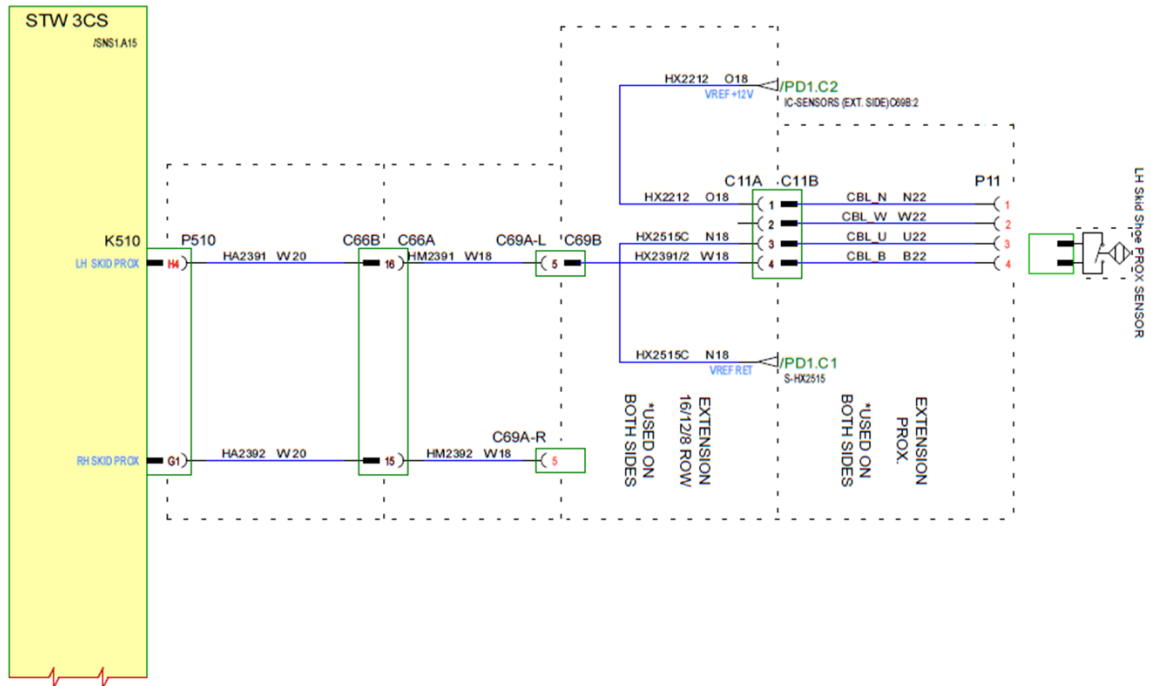

13.5. Lighting

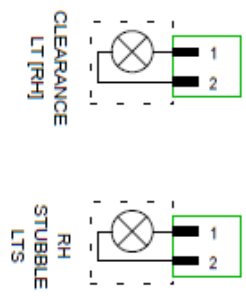
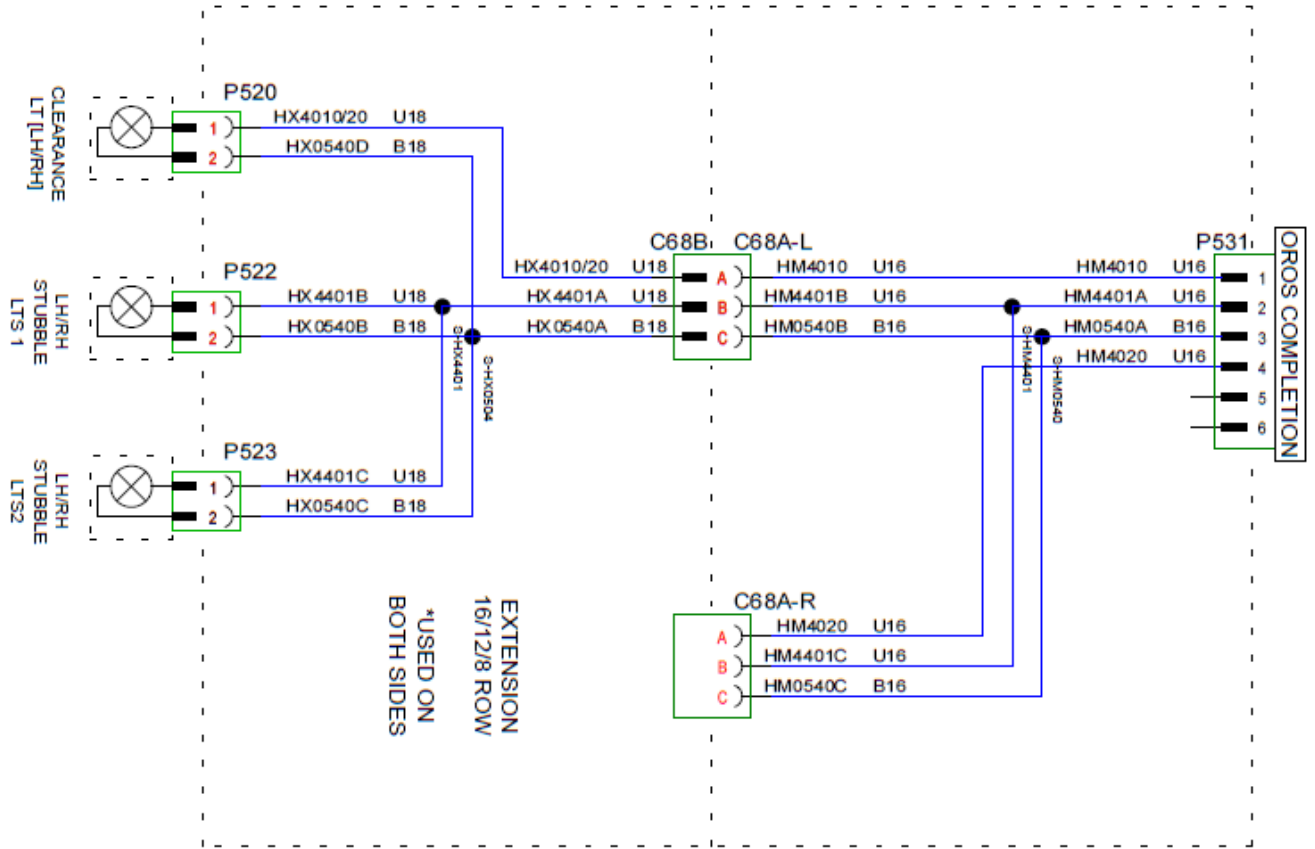

13.6. Networks

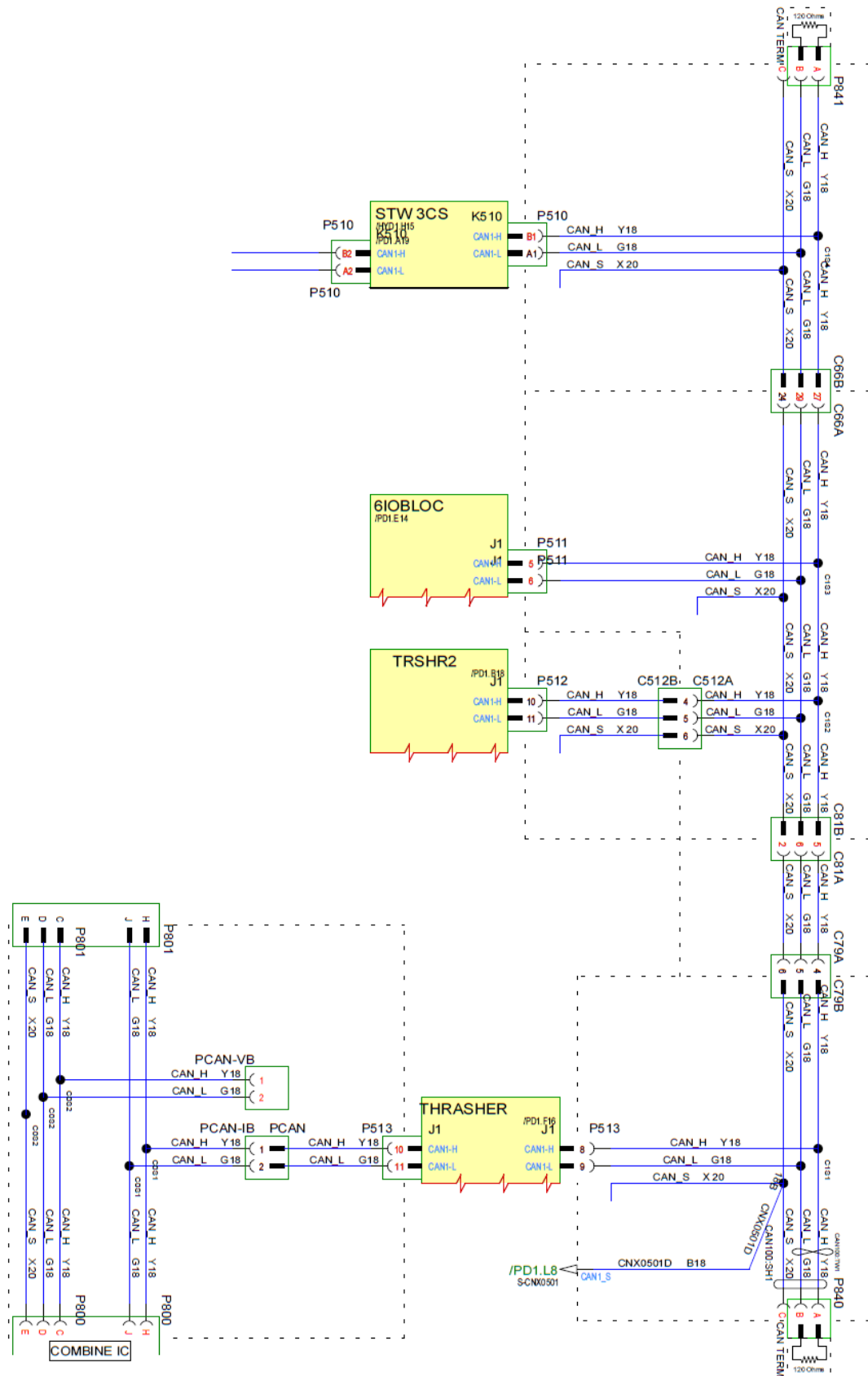

13.7. Connectors 1

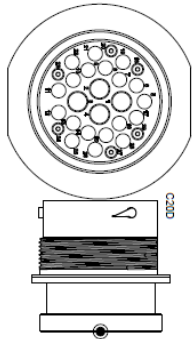

C200
IC - HDR1, D2 [R]
252912
HDP24-24-29PE-L017 DEUTSCH, HDP,
PLUG, 29M, BLK, SEALED
BACKSHELL: 2428-010-2405

1	HM0707	NI	16	HM4402	NI
2	HM0531A	NI	17	HM4020	NI
3	HM0531B	NI	18	CANLH	AU
4	HM4401	NI	19	HM2135	NI
5	HM4010	NI	20	HM2134	NI
6	HM2184	NI	21	HM0504A	NI
7	HM2184	NI	22	CANL S	AU
8	HM0777A	NI	23	HM0777A	NI
9	HM0777A	NI	24	NI	NI
10	HM0577	NI	25	NI	NI
11	HM231A	NI	26	HM2370A	NI
12	HM2332	NI	27	HM2372	NI
13	HM2333	NI	28	HM2373	NI
14	HM2334	NI	29	HM2375	NI
15	HM2335	NI			
16	HM2336	NI			
17	HM2337	NI			
18	HM2338	NI			
19	HM2339	NI			

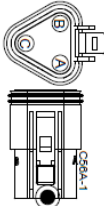

C56A-1
IC - REEL SENSORS [R]
134040
DT06-3S-P012, DEUTSCH, DT,
PLUG, 3F, BLK, SEALED
LOCK: W3S-P012
BACKSHELL: 1011-231-0305

A	HM2186	NI
B	HM2186E	NI
C	HM2370	NI

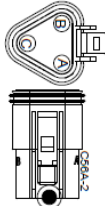

C56A-2
IC - REEL SENSORS [R]
134040
DT06-3S-P012, DEUTSCH, DT,
PLUG, 3F, BLK, SEALED
LOCK: W3S-P012
BACKSHELL: 1011-231-0305

A	HM2186E	NI
B	HM2186E	NI
C	HM2370C	NI

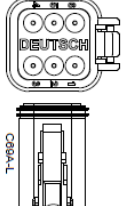

C69A-L
TRANSPORT LIGHTS LHS [R]
134036
DT06-6S-P012, DEUTSCH, DT,
RECP, 6F, BLK, SEALED
LOCK: W8S-P012
BACKSHELL: 1011-239-0805
CAP: 1011-347-0805

1	HM4141B	NI
2	HM0511B	NI
3	HM4131B	NI
4	HM4111B	NI
5	HM4121B	NI
6	HM4151B	NI

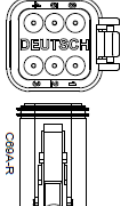

C69A-R
TRANSPORT LIGHTS RHS [R]
134036
DT06-6S-P012, DEUTSCH, DT,
RECP, 6F, BLK, SEALED
LOCK: W8S-P012
BACKSHELL: 1011-239-0805
CAP: 1011-347-0805

1	HM4141C	NI
2	HM0511C	NI
3	HM4131C	NI
4	HM4111C	NI
5	HM4121C	NI
6	HM4151C	NI

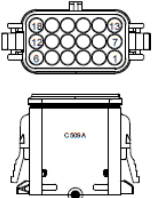

C609A
IC - EXTS TV (HDR SIDE)
AT16-18SA-K004, AMPHENOL, AT
PLUG, 18F, BLK, SEALED
BACKSHELL: ATBS-P6-1805

1	HM0707	NI	10	CANL H	AU
2	HM0777B	NI	11	CANL S	AU
3	HM0531C	NI	12	CANL S	AU
4	HM2371	NI	13	HM2375M	NI
5	HM2370	NI	14	HM2337	NI
6	HM2142	NI	15	HM2217Z	NI
7	HM2142	NI	16	HM2516Z	NI
8	HM0577	NI	17	HM2317A	NI
9	HM2375B	NI	18	HM2517A	NI

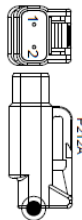

P212A
D2 - CONFIG SKDK [R]
134410
DT06-2S-P012, DEUTSCH, DTM, PLUG,
2F, GRAY, SEALED
LOCK: WM-2S
BACKSHELL: 1028-041-0205

1	HM2314	NI
2	HM231B	NI

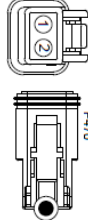

P470
DECKSHIFT RIGHT [R]
134029
DT06-2S-P012, DEUTSCH, DT,
PLUG, 2F, BLK, SEALED
LOCK: W2S-P012
BACKSHELL: 1011-227-0205
CAP: 1011-344-0205

1	HM2134	NI
2	HM0531K	NI

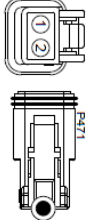

P471
DECKSHIFT LEFT [R]
134029
DT06-2S-P012, DEUTSCH, DT,
PLUG, 2F, BLK, SEALED
LOCK: W2S-P012
BACKSHELL: 1011-227-0205
CAP: 1011-344-0205

1	HM2135	NI
2	HM0531J	NI

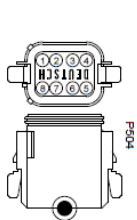

P504
TRANSPORT LTS MOD O/P [R]
134583
DT06-08SB-P012, DEUTSCH, DT,
PLUG, 8F, BLK, SEALED
LOCK: W8S-P012
BACKSHELL: 1011-244-0805
CAP: 1011-348-0805

1	HM4141A	NI
2	HM2314A	NI
3	HM4131A	NI
4	HM4111A	NI
5	HM4121A	NI
6	HM4151A	NI
7		
8		

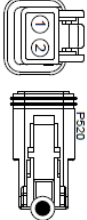

P520
LHTURN LIGHT [R]
134029
DT06-2S-P012, DEUTSCH, DT,
PLUG, 2F, BLK, SEALED
LOCK: W2S-P012
BACKSHELL: 1011-227-0205

1	HM4010	NI
2	HM0504B	NI

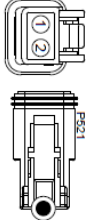

P521
RHTURN LIGHT [R]
134029
DT06-2S-P012, DEUTSCH, DT,
PLUG, 2F, BLK, SEALED
LOCK: W2S-P012
BACKSHELL: 1011-227-0205

1	HM4020	NI
2	HM0504C	NI

13.8. Connectors 2

C69A-L
IC - LH EXT SENSOR
134036
DTM06-6S-P012, DEUTSCH, DT,
RECP1, 6F, BLK, SEALED
WEDGELOCK: W6S-P012

1	HM0212C	NI
2	HM0212C	NI
3	HM0212C	NI
4	HM0212C	NI
5	HM0212C	NI
6	HM0212C	NI

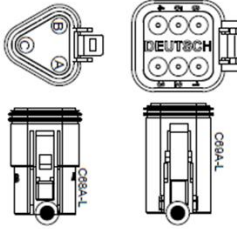

C68A-L
IC-LH EXT LIGHTS
134030
DTM06-3S-P012, DEUTSCH, DT,
PLUG, 3F, BLK, SEALED
WEDGELOCK: W3S-P012

A	HM44010	NI
B	HM44010	NI
C	HM02408	NI

P990
RELAY TRANSISTOR
134156
DTM06-4S, DEUTSCH, DTM, PLUG,
4S, GRAY, SEALED
WEDGELOCK: WM4S

1	HM0711	NI
2	HM2332	NI
3	HM0501H	NI
4		

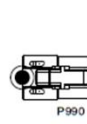

P100
RELAY
134917
12077993, DELPHI, MP 630
SPECIAL, PLUG, SF, BLK,
SEALED
RELAY: 7794307

86	HM0710E	SN
30	HM0710E	SN
88	HM0711	SN
87	HM077E	SN
87a		

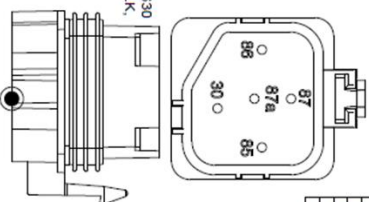

C512A
CAN PWR DROP
Macdon # 134584
DTM06-6S-E004, DEUTSCH, DTM,
PLUG, 6F, BLK, SEALED
WEDGELOCK: WM-6S

1	HM0710D	NI
2	HM0770	NI
3	HM0501E	NI
4	CAN H	AU
5	CAN L	AU
6	CAN S	AU

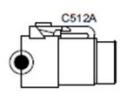

P511
MODULE-CAN-ANALOG
252003
DTM06-12SA, DEUTSCH, DT, PLUG,
12F, GRAY, SEALED
WEDGELOCK: W12S

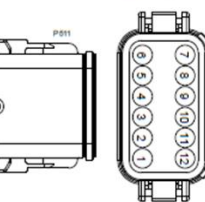

1	HM0770C	NI
2	HM0770C	NI
3	HM0533D	NI
4	HM0501J	NI
5	CAN H	AU
6	CAN L	AU
7	HM2384	NI
8	HM2385	NI
9	HM2386	NI
10		
11		
12		

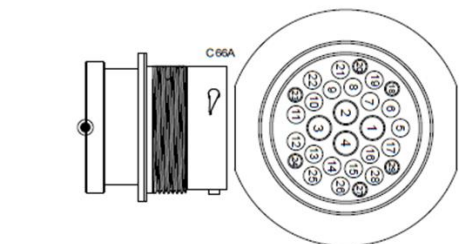

C66A
IC - STW MAIN [MAIN]
252935
HDP24-24-28SE1017, DEUTSCH, HDP,
RECP1 (REV), 29F, BLK, SEALED

1	HM0710B	NI
2		
3	HM0501B	NI
4	HM0501C	NI
5		
6		
7		
8		
9		
10		
11		
12	HM2172	NI
13	HM2172	NI
14	HM2173	NI
15	HM2382	NI
16	HM2381	NI
17	HM2381	NI
18	HM2215A	NI
19	HM3327	NI
20	HM2515A	NI
21	HM3328	NI
22	HM3330	NI
23	HM2212A	NI
24	CAN S	AU

C69A-R

IC - RH EXT SENSOR

134036

DT06-6S-P012, DEUTSCH, DT,

RECPT, 6F, BLK, SEALED

WEDGELOCK: W6S-P012

1	HM2215B	NI
2	HM2212B	NI
3	HM2515B	NI
4	HM3328	NI
5	HM2392	NI
6		

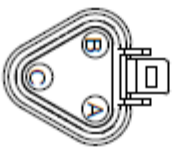
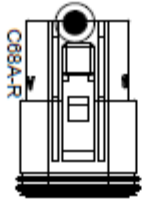
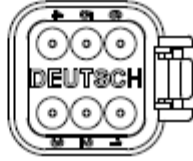
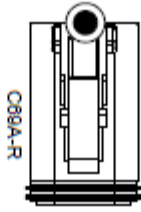

C68A-R

IC-RH EXT. LIGHTS

134040

DT06-3S-P012, DEUTSCH, DT,

PLUG, 3F, BLK, SEALED

WEDGELOCK: W3S-P012

A	HM4020	NI
B	HM4401C	NI
C	HM0540C	NI

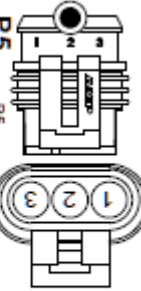

P5

LH WING POSITION

134091

282087-1, TYCO, SUPERSEAL 1.5,

PLUG, 3F, BLK, SEALED

1	HM2515E	SN
2	HM2212E	SN
3	HM3300	SN

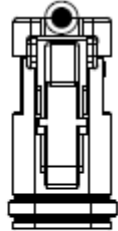

P28

LH FLEX LIFT LOCK

500317

DT06-2S-EP06, DEUTSCH, DT,

PLUG, 2F, BLK, SEALED

LOCK: W2S-P012

1	HM2172	NI
2	HM0501F	NI



P13
RH ROW GUIDE

134091
282087-1, TYCO, SUPERSEAL 1.5,
PLUG, 3F, BLK, SEALED

1	HM2531	Sn
2	HM2231	Sn
3	HM2403	Sn

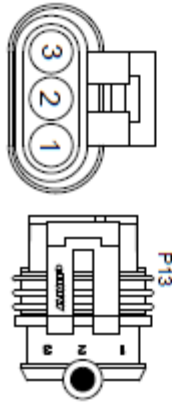

P12
LH ROW GUIDE

134091
282087-1, TYCO, SUPERSEAL 1.5,
PLUG, 3F, BLK, SEALED

1	HM2530B	Sn
2	HM2230B	Sn
3	HM2401	Sn

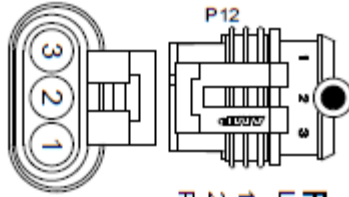

C81B
IC - CAB CONTROL

283035
HD34-18-6PN-059, DEUTSCH, HD,
RECP, 6M, METAL, SEALED
W/BACKSHELL

1	HM077A	NI
2	CAN S	AU
3	HM0710A	NI
4	HM0501A	NI
5	CAN H	AU
6	CAN L	AU

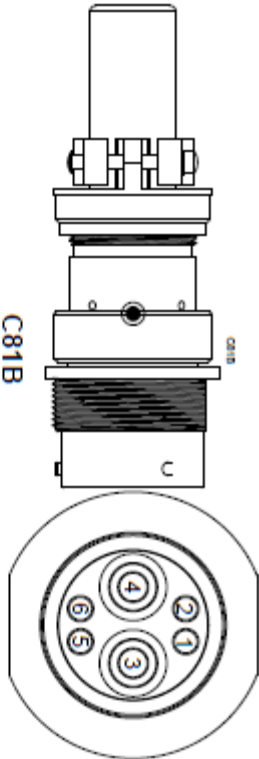

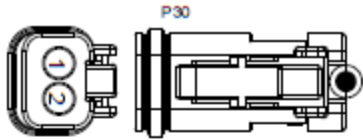

P30
RH FLEX LIFT LOCK
500317
DT06-2S-EP08, DEUTSCH, DT.[®]
PLUG, 2F, BLK, SEALED
LOCK: W2S-P012

1	HM2173	NI
2	HM0507G	NI

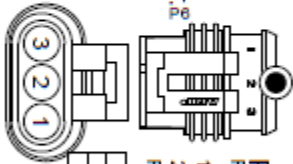

P6
RH WING POSITION
134091
282087-1, TYCO, SUPERSEAL 1.5,
PLUG, 3F, BLK, SEALED

1	HM251F	SN
2	HM221F	SN
3	HM3331	SN

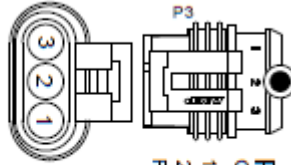

P3
Center AHHC Dongle
134091
282087-1, TYCO, SUPERSEAL 1.5,
PLUG, 3F, BLK, SEALED

1	HM251D	SN
2	HM221D	SN
3	HM3327	SN

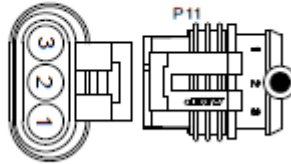

P11
RH ROW GUIDE
134091
282087-1, TYCO, SUPERSEAL 1.5,
PLUG, 3F, BLK, SEALED

1	HM2530C	SN
2	HM2230C	SN
3	HM2402	SN

ELECTRICAL SCHEMATICS

P504
LH AHHC [B]
134690
282105-1, TYCO, Superseal 1.5,
RECPT, 3M, BLK, SEALED

1	HM2532A	Sn
2		
3	HM2394	Sn

P505
CTR AHHC [C]
134690
282105-1, TYCO, Superseal 1.5,
RECPT, 3M, BLK, SEALED

1	HM2532B	Sn
2	HM2232	Sn
3	HM2395	Sn

P506
RH AHHC [D]
134690
282105-1, TYCO, Superseal 1.5,
RECPT, 3M, BLK, SEALED

1	HM2532C	Sn
2		
3	HM2396	Sn

1	HM2532A	Sn
2	HM2532B	Sn
3	HM2532C	Sn
4	HM2302	Sn

P508
ROW GUIDANCE [G]
282106-1, TYCO, SUPERSEAL 1.5,
RECPT., 4M, BLK, SEALED

P529
DECKPLATE POSITION
134690
282105-1, TYCO, Superseal 1.5,
RECPT, 3M, BLK, SEALED

1	HM2531	Sn
2	HM2231	Sn
3	HM2403	Sn

1	HM2510	Sn
2	HM2511	Sn
3	HM2512	Sn
4	HM2513	Sn
5	HM2514	Sn
6	HM2515	Sn

P531
LIGHTING [F]
134780
C018, 10X008 000 10 AMPHENOL,
ECO MATE, PLUG, 6M, BLUE,
SEALED

13.2. Electrical schematic for the adapter

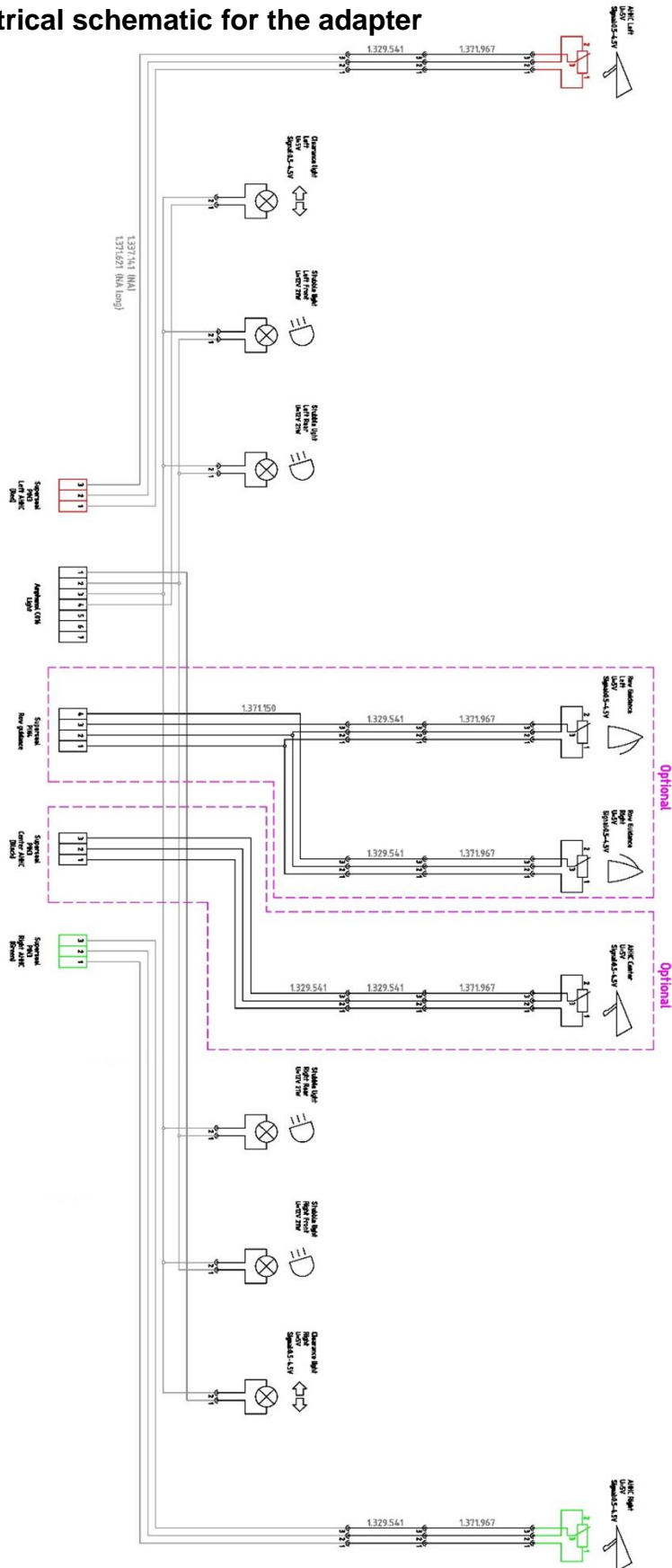

14. TROUBLE SHOOTING

14.1. A large quantity of ears builds up between the auger and feeder.

This can result from improper adjustment of the combine for corn harvesting operation, including front feeder drum (rock retarder drum) position too low, threshing component speed, concave clearance or angle of the feeder front face. Ensure that the combine is adjusted for corn harvesting in accordance with the instructions and settings as recommended in the combine operator's manual.

14.2. In laid or lodged corn stalks, the stalks do not feed properly into the snapping rolls.

First, remove ear savers from the top of the snouts.

If the crop is severely laid or lodged it may be necessary to remove one or both of the rubber ear savers from the rear of the snouts to improve feeding to the row units.

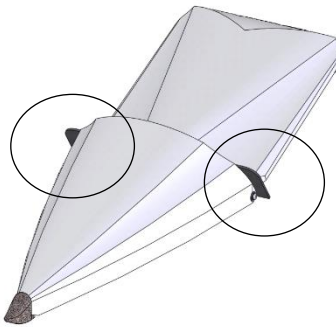

14.3. Row unit becomes plugged while harvesting laid or lodged cornstalks.

Ensure gathering chain tensioner is moving freely. Confirm the snapping plates are set to specification.

See "Gathering chain tensioner" section 10.5.4 and "Setting fixed snapping plate" section 10.5.2.1.

14.4. Stalks, grass or weeds wrap on the snapping roll.

Reduce gap of vine knives.

See "Vine Knife Adjustment" section 9.5.3.

14.5. Auger does not rotate.

Check that auger is free of blockages then Check auger drive chain tension.

See "Auger setup" section 9.2.

14.6. Ears are broken or split in the auger.

Reduce the rotational speed of the auger using the optional sprocket. Or raise the auger higher from the floor.

See “Auger setup”, section 9.2.

13.7. Checks to resolve feeding issues in dry crop

Check correct settings:
Are the snapping plates set correctly? 3/4" at the front and 15/16" at the rear when fully closed. Use tool to confirm if possible
Are all of the snapping plates moving together? Be sure the clamps to the moving rod are tight
Make sure there is nothing impeding the crop flow into the row unit path
Operation
Speeding the header up tends to reduce MOG (Material Other than Grain).
Slow down to allow header more time to process the plants
Increasing snapping plate opening will reduce trash intake
Reduce header angle. Be sure angle is not more than 23 degrees
Cut slightly higher to reduce trash
Setting changes/configurations
Increase auger speed by using 18t or 20t auger drive sprocket
Increase auger height above floor - Set to 1.5 inches for rigid frame headers. Folding frame augers are not adjustable.
Start with reverse flighting center configuration, combined with rubber auger flaps
Increase gap at front of snapping rolls - can change from setting of <1mm to 2-3 mm. After adjustment, confirm the vine knives are not touching the rolls. Do not exceed 5 mm of clearance. Operators manual section 8.5.1.1
Flip center 2 row unit gathering chains and run them backwards. (4 chains total) In some conditions, this can improve flow at the center.
If crop is breaking off at the front of the row, or in lodged crop, earsavers can be removed. Start by removing one, then the second if needed.

14.8 Flex System

- General Flex System Diagnostics
 - Generic diagnostic information is available through the FlexCorn display.
 - Input and output signals can be used to diagnose and troubleshoot component and harness issues.
 - Active and Previously Active faults can guide troubleshooting effort.
 - Navigate to Diagnostics Screen

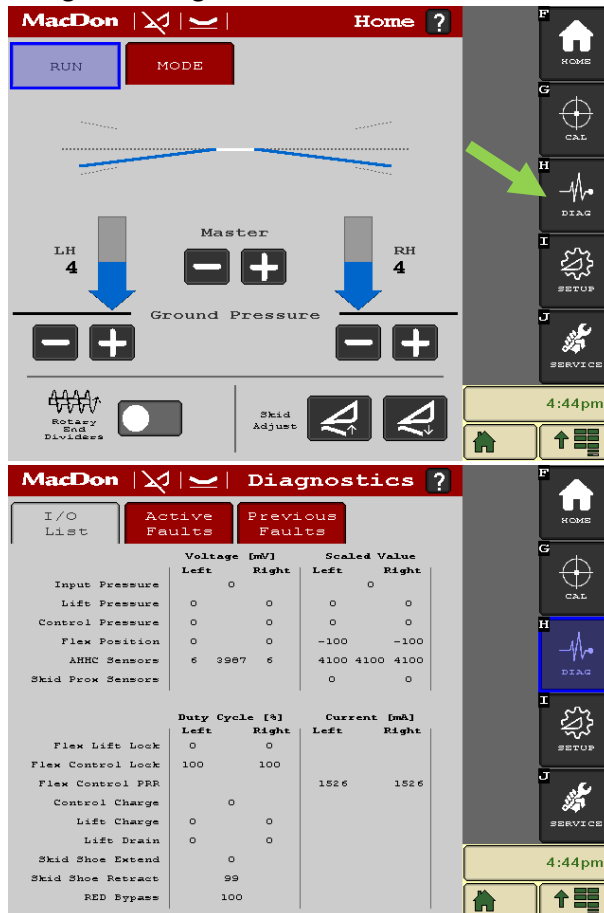

- General diagnostics information is shown on the diagnostic I/O screen
 - Input signals are shown in the middle portion of the screen
 - Raw input voltages (mV) are shown in the columns at the left
 - Scaled input values are shown in the columns at the right
 - Output signals are shown in the bottom portion of the screen
 - Duty cycle (0-100%) signals are shown in the columns at the left
 - Current (mA) signals are shown in the columns at the right

- Navigate to Active Faults Screen

MacDon Diagnostics

I/O List | **Active Faults** | Previous Faults

	Voltage [mV]		Scaled Value	
	Left	Right	Left	Right
Input Pressure	0	0	0	0
Lift Pressure	0	0	0	0
Control Pressure	0	0	0	0
Flex Position	0	0	-100	-100
AHHC Sensors	6 3987 6		4100 4100 4100	
Skid Prox Sensors			0	0

	Duty Cycle [%]		Current [mA]	
	Left	Right	Left	Right
Flex Lift Lock	0	0		
Flex Control Lock	100	100		
Flex Control PRR			1526	1526
Control Charge		0		
Lift Charge	0	0		
Lift Drain	0	0		
Skid Shoe Extend		0		
Skid Shoe Retract		99		
RED Bypass		100		

4:44pm

- Any currently active faults will appear on the screen

MacDon Diagnostics

I/O List | **Active Faults** | Previous Faults

SPN	FMI	OCC
LH AHHC Sensor Signal	4: Voltage Below Normal Or Shorted To Low Source	1
RM AHHC Sensor Signal	4: Voltage Below Normal Or Shorted To Low Source	1
LH Wing Sensor Signal	4: Voltage Below Normal Or Shorted To Low Source	1
RM Wing Sensor Signal	4: Voltage Below Normal Or Shorted To Low Source	1
LH Lift Press Sensor Signal	4: Voltage Below Normal Or Shorted To Low Source	1
RM Lift Press Sensor Signal	4: Voltage Below Normal Or Shorted To Low Source	1
LH Ctrl Press Sensor Signal	4: Voltage Below Normal Or Shorted To Low Source	1
Input Press Sensor Signal	4: Voltage Below Normal Or Shorted To Low Source	1
Center AHHC Sensor	15: Data Valid But Above Normal Operating Range Least Severe	1
LH AHHC Sensor	17: Data Valid But Below Normal Operating Range Least Severe	1

4:44pm

- Navigate to Previously Active Faults Screen

MacDon Diagnostics

I/O List | Active Faults | **Previously Faults**

	Voltage [mV]		Scaled Value	
	Left	Right	Left	Right
Input Pressure	0	0	0	0
Lift Pressure	0	0	0	0
Control Pressure	0	0	0	0
Flex Position	0	0	-100	-100
AHHC Sensors	6 3987 6		4100 4100 4100	
Skid Prox Sensors			0	0

	Duty Cycle [%]		Current [mA]	
	Left	Right	Left	Right
Flex Lift Lock	0	0		
Flex Control Lock	100	100		
Flex Control PRR			1526	1526
Control Charge		0		
Lift Charge	0	0		
Lift Drain	0	0		
Skid Shoe Extend		0		
Skid Shoe Retract		99		
RED Bypass		100		

4:44pm

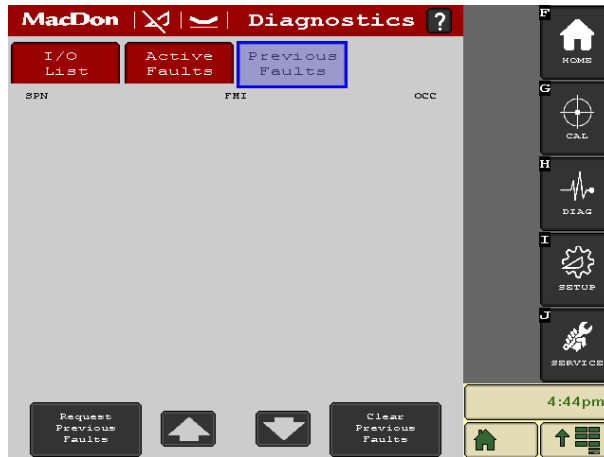

- Diagnostic help information can also be viewed by pressing the help button from the diagnostic screens

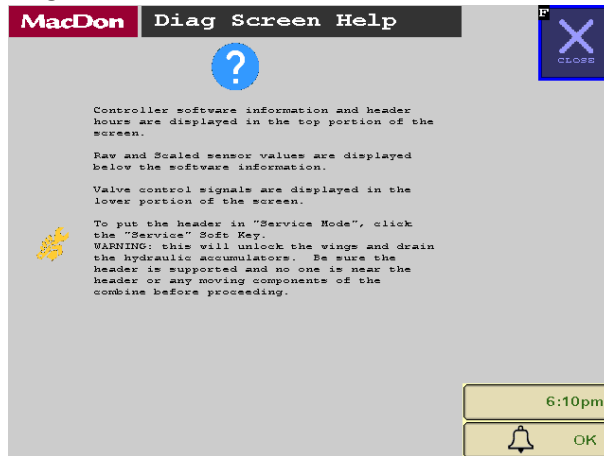

14.9 Specific Issue Troubleshooting

- Skid Shoes not retracting to home position.
 - Clear skid shoe top of debris
 - Check skid shoe proximity sensor by passing metal in front of it and seeing if the base of the sensor lights up.

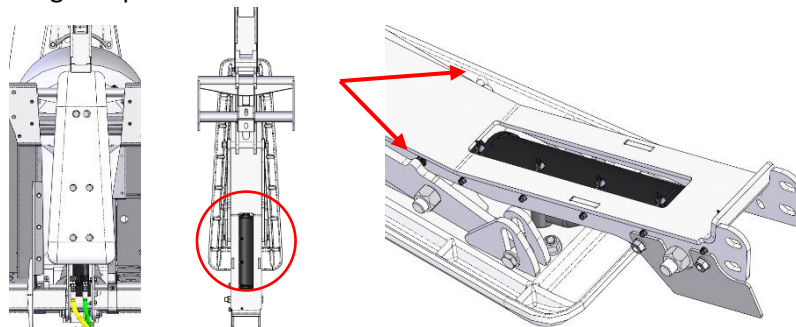

- Adjust proximity sensor gap closer to skid shoe linkage (2-4mm gap)
- Search for damage to the wiring harness

TROUBLE SHOOTING

- Header wings won't lower or get hung up.
 - Check to see if lock links were left installed.
 - Increase ground pressure setting.
 - Check for interference between linkages and frame components.
 - Check for material lodged between wing and center frame seal.
- Crop loss at the feeder house opening.
 - Check rubber seal between LH auger pan and RH auger pan.
 - Check wing to center frame transition seal. Refer to section 9.11.
- Wings not kicking at the end of a pass.
 - Check AHHC dongles to make sure they are not stuck or damaged.
 - Use display diagnostic screen to ensure scaled voltage of AHHC sensors is greater than 4.1 V. If scaled voltage is not greater than 4.1 volts, recalibrate header AHHC system, then recalibrate combine AHHC system.
- Wings not level in rigid mode.
 - Install flex lock links.
 - Switch header control to "service mode" following instructions in section 10.3.7
 - Adjust both left and right wing position sensors until they read 2.5 Volts on the display diagnostic screen. This is adjusted by rotating the sensor for coarse adjustment, or by adjusting the linkage for fine adjustment. Retighten sensor and/or jam nuts on linkage.

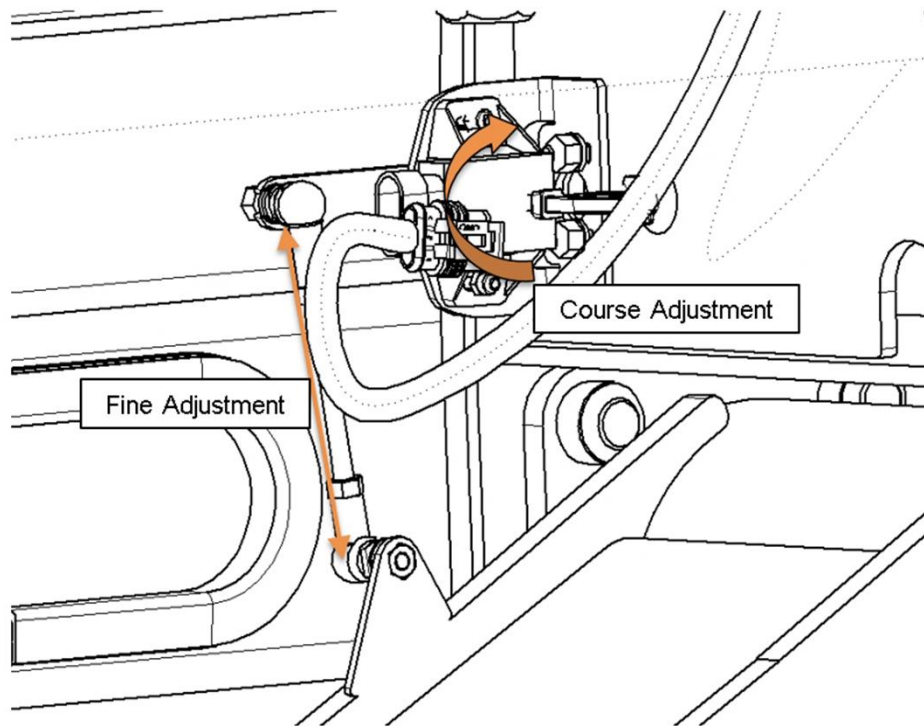

15. OFF-SEASON STORAGE OF YOUR CORN HEAD

When harvesting is completed, thoroughly clean the corn head and remove all remaining debris. Carefully inspect the corn head to ensure it will be in proper operating condition for the next season. Repaint any paint-damaged area to prevent rusting. If this is not possible, coat the unpainted area with rust protector. Repair or replace any damaged or missing parts, including safety labels.

If possible, store the corn head in a covered place. Before storage, lubricate the slides on the gathering chain front idlers, gathering chains, and auger drive chains.

For flexing corn head: place header in rigid mode (10.3.3) to ensure the skid shoes are fully retracted, install lock links (9.10), and drain accumulators by entering service mode (10.3.7).











Header can be left on a suitable trailer or set on the ground using integrated header stands.

16. WARRANTY, SERVICE, SPARE PARTS ORDERING

MacDon provides warranty for Customers who operate and maintain their equipment as described in this manual. A copy of the MacDon Industries Limited Warranty Policy, which explains this warranty, should have been provided to you by your Dealer. Damage resulting from any of the following conditions will void the warranty:

- Accident
- Misuse
- Abuse
- Improper maintenance or neglect
- Abnormal or extraordinary use of the machine
- Failure to use the machine, equipment, component, or part in accordance with the manufacturer's instructions

17. LUBRICATION CHART

Lubrication table			
#	type	period	qty.
1	 EP NLGI Grade 2*	250 [h]	look at operator's manual
2	 EP-00 grease	250 [h]	5,5 [pounds] 2,5 [kg]
3	 EP NLGI Grade 2*	250 [h]	look at operator's manual
4	 EP NLGI Grade 2*	50 [h]	look at operator's manual
5	 EP NLGI Grade 2*	50 [h]	look at operator's manual
6	 EP NLGI Grade 2*	250 [h]	look at operator's manual
7	 EP NLGI Grade 2*	250 [h]	look at operator's manual
8	 Gearbox oil	50 [h]	look at operator's manual
9	 Gearbox oil	10 [h]	look at operator's manual
10	 SAE 80W-140**	50 [h]	10,15 [fl.oz.] 0,3 [l]
11	 SAE 80W-140**	250 [h]	30,45 [fl.oz.] 0,9 [l]

*high temperature, 1% max molybdenum disulphide, lithium base
**SAE 85W-140 can be used as an alternative

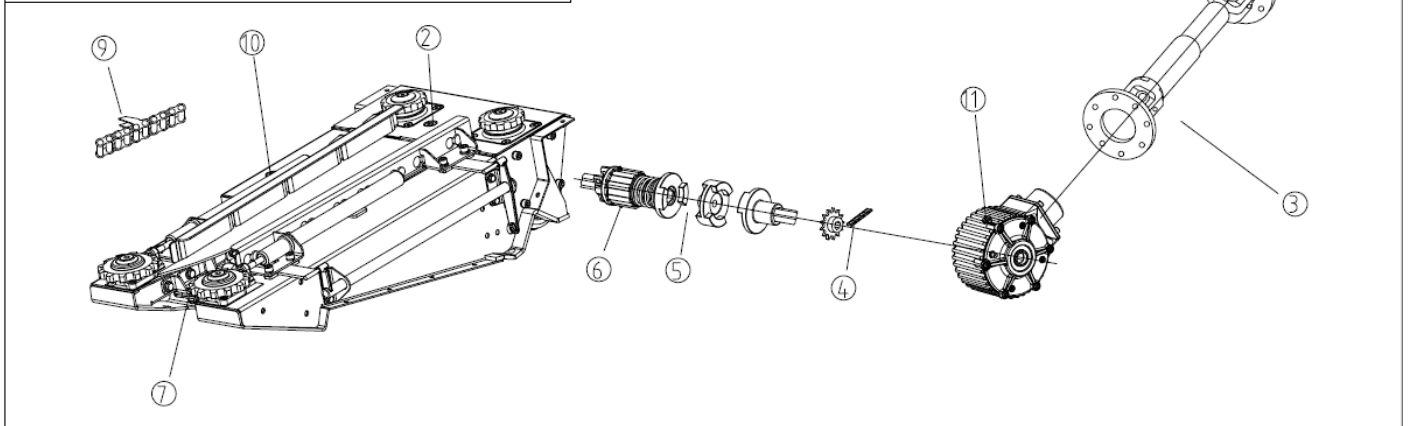

Flex linkage lubrication chart 50 [h]

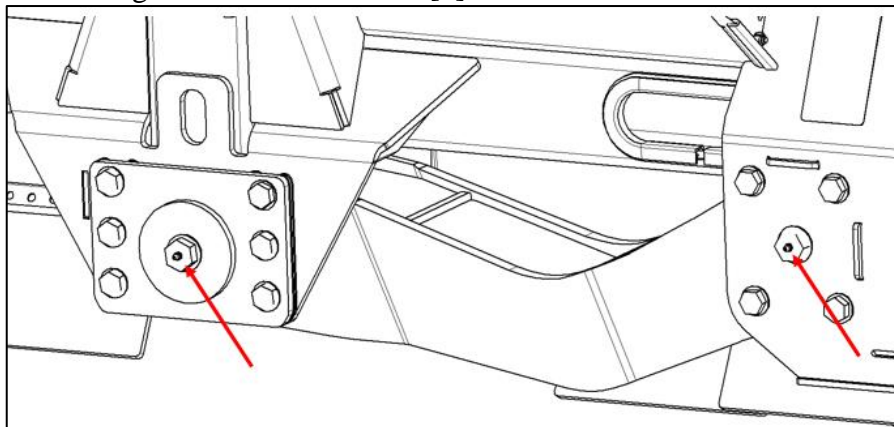

LUBRICATION CHART

✓	#	Description	Interval	Specification	Reference
		Check Chopper knife blade and hardware condition (If equipped)	daily		7.5.1.1
		Check snapping roll knife condition	daily		11.5.2
		Check gathering chains for abnormal wear	daily		11.5.3
	8	Check auger drive chain(s) tension (2 per header)	50 [h]	19mm of deflection at slack side	7.2 / 11.2
	8	Lubricate auger drive chains (2 per header)	50 [h]	Chain lubricant or SAE 30W	7.2 / 11.2
		Clean area around auger drive chains	50 [h]		11,2
	10	Check stalk chopper gearbox oil level, if equipped	50 [h]	Check dipstick with header in harvesting position.	11.5.1
	2	Check row unit grease level (1 per row, fill as required)	After first 50 [h] then 250 [h] or annually	2.5L of EP-00	11.5.1
	11	Check drive and driven gearbox(s) (header drive) oil level (4 per header)	50 [h]	Remove oil check plug with header in harvesting position, oil should be at the threads of the hole.	11,3
	11	Change stalk chopper gearbox oil, if equipped (1 per row)	250 [h] or annually	0.3L of SAE 80W-140 or SAE 85W-140	11.3?
	11	Change drive and driven gearbox oil levels (4 per header)	After first 50 [h] then 250 [h] or annually	0.9L of SAE 80W-140 or SAE 85W-140	11,3
		Grease lower link pivot points (4 per header)	50 [h]	EP NLGI Grade 2	
	1	Grease header drive shaft (2 per header, 5 places each)	250 [h] or annually	EP2 - 10% max molybdenum	7,6
	4	Grease hex shaft chain couplings	250 [h] or annually	Chain lubricant or SAE 30W	11.4.2
	6	Grease slip clutches (2 places per row)	250 [h] or annually	EP NLGI Grade 2	11.4.2
	7	Grease front grease fitting of snapping rolls (2 places per row)	100 [h] or annually	EP NLGI Grade 2	11.5.2
		Lubricate Snapping plate indicator cable	250 [h] or annually	Chain lubricant or SAE 30W	7.5.2
		Lubricate Flex linkage	50 [h]		17.1

PRE-HARVESTING INSTRUCTIONS

18. PRE-HARVESTING INSTRUCTIONS

18.1 Pre-harvesting check list

✓	Item	Reference
	POWER HARNESS INSTALLED	6.1
	CAB HARNESS INSTALLED	6.2
	LOWER LATCHES PROPERLY CONNECTED TO COMBINE FEEDER	7.1
	CORN HEAD AND SNOUTS ARE LEVEL	9.8
	DRIVE SHAFTS PROPERLY CONNECTED TO COMBINE FEEDER	7.2
	LOCKING LINK STOPS REMOVED	9.10
	ELECTRIC AND HYDRAULICS PROPERLY CONNECTED	7.2
	UT PROPERLY LOADS ONTO COMBINE	7
	SNAPPING PLATE ADJUSTMENT	9.4.2
	GATHERING CHAIN PROPERLY TENSIONED	9.4.4
	AUGER DRIVE CHAINS PROPERLY TENSIONED	12.2
	AUGER GAP CORRECT	9.2
	AUGERS TIMED CORRECTLY	9.3
	SNOUTS AND DIVIDERS ADJUSTED AND SECURED	9.7
	SAFETY SHIELDS SECURED	-
	GEARBOX LUBRICANT TO PROPER LEVELS	12 17
	SNAPPING ROLL CLEARANCES	9.4.1 15.1.1
	ALL NUTS AND BOLTS ARE SECURED	-
	FREE ROTATION OF CHOPPER KNIVES (IF APPLICABLE)	15.1
	FLEX POSITION SENSORS ARE PROPERLY ADJUSTED	18.2.1
	HEADER CALBRATES	7.6
	SKID SHOES TRIGGER WHEN PROXIMITY SENSOR RETRACTED	18.2.2

18.2 Pre-harvesting instructions

18.2.1 Flex Position Sensor adjustment procedure.

Flex position sensors should be properly adjusted so the header returns to level when it is placed in rigid mode and to easily install lock links when needed.

1. Install lock links.
2. Place header in service mode.
3. Navigate to diagnostics I/o page on the Universal Terminal Application.
4. If Necessary, adjust flex position sensor linkages until voltage readout is 2.5 volts +/- 0.1 volts.

18.2.2 Skid shoe sensor adjustment procedure.

Skid shoe proximity sensors should be properly adjusted to ensure skid shoes are raised when enabling rigid mode or for transporting on a trailer.

Before beginning procedure, ensure area is clear of any bystanders.

With combine and header running:

1. Lift header off the ground.
2. Place header in rigid or flex mode.
3. Press and hold the skid shoe retract button on home screen for 10 seconds.
4. Navigate to diagnostics I/O page.
5. Skid shoe proximity sensor should read "1". If both readings are "1" sensors are set correctly.
 - a. If one or both sensor readings are "0" troubleshooting is required.

18.2.3 Proximity sensor troubleshooting.

- A. With combine and header running, raise header then press and hold the skid shoe extend button on home screen for 10 seconds to fully extend skid shoes.
 - B. Place header in rigid mode
 - C. Engage feederhouse lock, turn off combine and remove key from ignition.
 - D. install header lock links.
 - E. Ensure all debris is removed from the skid shoes and linkage.
 - F. With Combine and header running, repeat steps 3-6 above.
 - i. If one or both sensor readings are "0" additional troubleshooting is required.
-
- A. With combine and header running, raise header then press and hold the skid shoe extend button on home screen for 10 seconds to fully extend skid shoes.
 - B. Turn off combine but leave key in accessory position.
 - C. Hold small piece of ferrous metal to end of sensor.
 - i. If the light on the wire end of sensor turns on, sensor is functioning and connected.
 - ii. If light is not functioning inspect wiring and sensor for damage.

PRE-HARVESTING INSTRUCTIONS

- iii. If sensor light is working but in-cab readout is still "0", sensor position requires adjustment. Adjust sensor until gap between sensor face and skid shoe linkage is 1-3mm (0.0625 - 0.125")
- D. D. If troubleshooting fails, replace sensor.

TORQUE VALUES

19. TORQUE VALUES

19.1 Torque values for fasteners

TORQUE VALUES FOR FASTENERS (Nm)			
SIZE	QUALITY		
BOLTS / SCREWS	8.8	10.9	12.9
NUTS	8.	10.	12.
M6	10	14	16
M8	23	33	40
M10	45	63	75
M12	78	110	130
M14	122	175	210
M16	195	270	325
M18	260	370	440
M20	370	525	630
M24	640	900	1080
M30	1260	1800	2160

TORQUE VALUES FOR FASTENERS (ft*lbs)			
SIZE	QUALITY		
BOLTS / SCREWS	8.8	10.9	12.9
NUTS	8.	10.	12.
M6	7	10	12
M8	17	24	30
M10	33	46	55
M12	58	81	96
M14	90	129	155
M16	144	199	240
M18	192	273	325
M20	273	387	465
M24	472	664	797
M30	929	1328	1593

TORQUE VALUES

19.2 Torque values for hydraulic fittings

19.2.1 L Series

Size	Minimum Tube Wall Thickness	Torque Value	
		Nm	lbf ft (*lbf in)
6	6 x 1	25	*221
8	8 x 1	40	30
10	10 x 1	50	37
12	12 x 1.5	70	52
15	15 x 1.5	90	66
18	18 x 1.5	115	85
22	22 x 2	210	155
28	28 x 2	310	229
35	35 x 3	500	369
42	42 x 3	600	443

19.2.2 S Series

Size	Minimum Tube Wall Thickness	Torque Value	
		Nm	lbf ft (*lbf in)
6	6 x 2	35	26
8	8 x 1.5	55	41
10	10 x 1.5	70	52
12	12 x 1.5	85	63
14	14 x 2	110	81
16	16 x 1.5	120	89
20	20 x 2	200	148
25	25 x 2.5	340	251
30	30 x 3	480	354
38	38 x 4	850	627

20 Appendix:
20.1 Hydraulic schematic

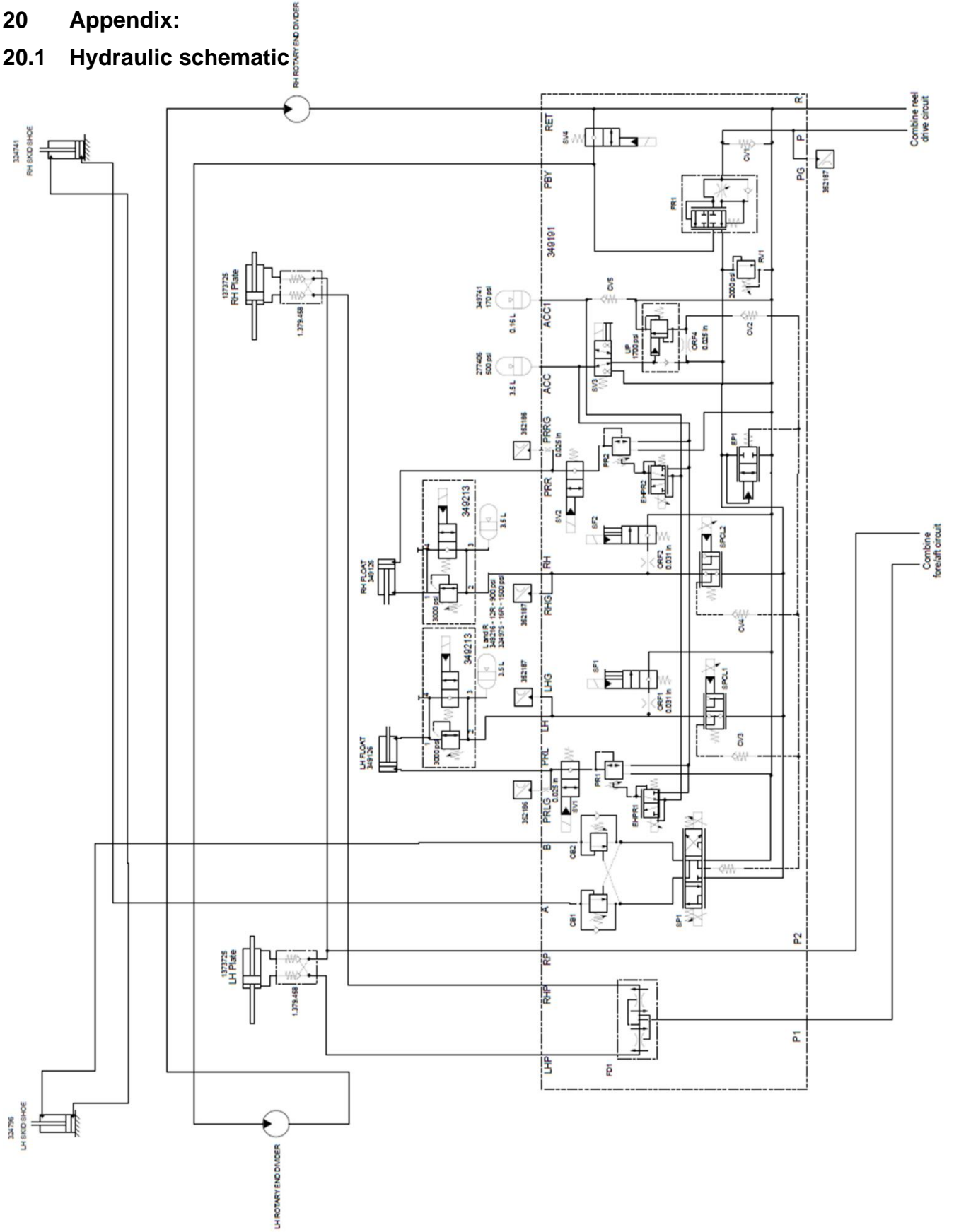

MacDon®

CUSTOMERS
MacDon.com

CUSTOMERS
MacDon.com

Trademarks of products are the marks of their
respective manufacturers and/or distributors.

Printed in Canada