

# Recommended Settings

Intended as a starting point. Fine-tune to crop and field conditions. Guidelines are subject to change without notice.

Crop Type	Stubble Height	Crop Condition	Divider Rods	Header Angle <sup>1</sup>	Knife Speed <sup>2</sup>	Reel Tine Pitch <sup>3</sup>	Reel Speed <sup>4</sup>	Reel Fore-Aft <sup>5</sup>	Skid Shoe Position <sup>6</sup>	Stabilizer Wheels	Upper Cross Augers	Float <sup>7</sup>
Cereals	0 in. (ground level)	Light	On	Shallow	High	2	10%–15%	6 or 7	1 or 2	Storage	Not Required	70 lbs.
		Normal			Medium		10%					
		Heavy		Middle	3	5%–10%	4 or 5					
	Lodged											
	4–8 in. (102–203 mm)	On	Light	Shallow	High	2	10%–15%	6 or 7	2 or 3	Variable	Not Required	70 lbs.
			Normal		Medium		10%		Variable			
Heavy			Variable	3	5%–10%	4 or 5						
Lodged												
10+ in. (254+ mm)	On	Light	Middle	High	2	10%–15%	6 or 7	Not Applicable	Variable	Not Required	150 lbs.	
		Normal		Medium		10%						
		Heavy	Variable	3	5%–10%	4 or 5						
Lodged												
Canola	4–8 in. (102–203 mm)	Light	On	Steep	Medium	2	5%–10%	6 or 7	Variable	Variable	Not Required	70–100 lbs.
		Normal			Low	1	10%		2 or 3			
		Heavy			2	5%–10%	3 or 4	2 or 3	Recommended			
	Lodged											
	10+ in. (254+ mm)	On	Light	Steep	Medium	4	5%–10%	6 or 7	Not Applicable	Variable	Not Required	150 lbs.
			Normal		Low	2	10%					
Heavy			3		5%–10%	3 or 4	Recommended					
Lodged												
Flax	2–6 in. (51–153 mm)	Light	On	Variable	High	2	5%–10%	6 or 7	2 or 3	Variable	Not Required	70–100 lbs.
		Normal					10%					
		Heavy										
Lodged												
Edible Beans	0 in. (ground level)	Light	Off	Steep	Medium	2	5%–10%	3 or 4	1 or 2	Storage	Not Required	100 lbs.
		Normal										
		Heavy										
Lodged	3											
Grass	0 in. (ground level)	Light	On	Variable	High	2	10%	6 or 7	1 or 2	Storage	Not Required	70–100 lbs.
		Normal										
		Heavy										
Lodged	10%–15%											
Alfalfa	0 in. (ground level)	Light	On	Variable	High	3	10%	6 or 7	1 or 2	Storage	Not Required	70–100 lbs.
		Normal				2						
		Heavy										
Lodged	3	10%–15%										

# Notes for using the Recommended Settings Chart

## <sup>1</sup>Header Angle

The header angle is varied by adjusting the length of the center link. It is used to adjust the angle of the guards and draper deck relative to the ground.

The angle is displayed as a value from 0 (shallow) to 10 (steep) on the windrower Cab Display Module (CDM).

## <sup>2</sup>Knife Speed

Displayed as actual strokes per minute on the windrower Cab Display Module (CDM).

**High** – Upper part of range

**Medium** – Middle of range

**Low** – Lower part of range

Header Size	Recommended Knife Speed Range (SPM)	
	Single Knife	Double Knife
15 ft.	---	1500–1900
20 and 25 ft.	1200–1400	1400–1700
30 ft.	1200–1400	1200–1600
35 ft.	1100–1300	1200–1400
40 ft.	1050–1200	1100–1400

## <sup>3</sup>Reel Tine Pitch

Turn cam latch pin (A) to unlock cam disc.

Use wrench on bolt (B) until latch pin lines up with appropriate Cam setting (C) between 1 and 4.

Increasing the cam setting increases the aggressiveness of the reel for picking up downed crop.

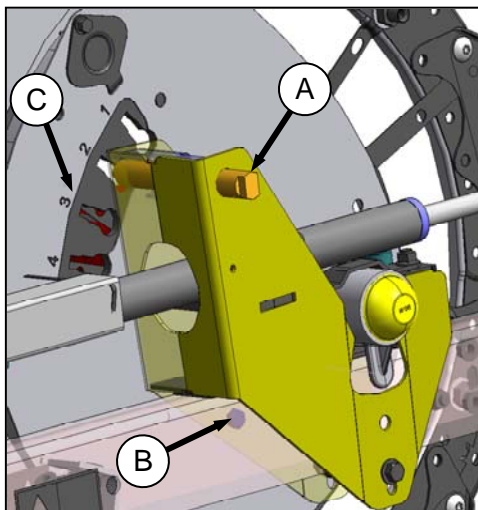

## <sup>4</sup>Reel Speed

Operate the reel at suggested percentage above ground speed.

Reel speed is displayed on the Cab Display Module in mph, km/h, or rpm, and is adjustable with the controls in the windrower cab.

## <sup>5</sup>Reel Fore-Aft

Use back edge of reel cam disc and decal on reel support arm as a gauge.

Adjust fore-aft position with fore-aft controls in windrower cab.

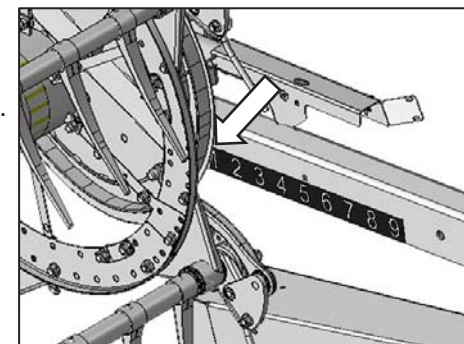

## <sup>6</sup>Skid Shoes

Remove lynch pin (D), disengage pin (E) from the frame, and move skid shoe (F) to desired position. There are three hole positions: top, middle, and bottom.

**For a lower cutting level,** raise the skid shoe by installing pin (E) in the bottom hole.

**For a higher cutting level,** lower the skid shoe by installing pin (E) in the top hole.

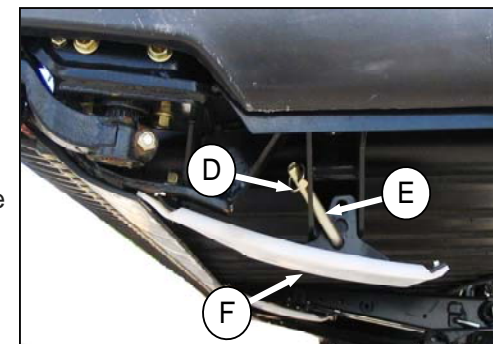

## <sup>6</sup>Float

The recommended float setting is 75–85 lbs. Rocky conditions, or cutting at faster ground speeds, may require that float be set heavier to prevent excessive header movement. See M-Series Operator's Manual for procedures.

## Draper Speed

Draper speed is to be set based on ground speed, crop mass, volume, and windrow formation. Faster ground speeds or heavier crop may require increased draper speeds to convey material. Slower ground speed or lighter crop may require slower draper speeds to ensure even crop flow. See M Series Operator's Manual.