

MacDon™
Model D50 and D60
Harvest Header®
with
CA20 Combine Adapter

UNLOADING and
ASSEMBLY INSTRUCTIONS
for
NORTH AMERICAN SHIPMENTS

INTRODUCTION

This instructional manual describes the unloading, set up and pre-delivery requirements for the MacDon D50 and D60 Harvest Headers[®] with a CA20 Combine Adapter.

Use the Table of Contents to guide you to specific areas.

Retain this manual for future reference.

CAREFULLY READ ALL THE MATERIAL PROVIDED BEFORE ATTEMPTING TO UNLOAD, ASSEMBLE, OR USE THE MACHINE.



D50 HARVEST HEADER[®]



D60 HARVEST HEADER[®]

TABLE OF CONTENTS

INTRODUCTION	2
GENERAL SAFETY	3
RECOMMENDED TORQUES	5
A. GENERAL	5
B. SAE BOLTS	5
C. METRIC BOLTS.....	5
D. HYDRAULIC FITTINGS.....	6
CONVERSION CHART	8
STEP 1. UNLOAD HEADER	9
STEP 2. LOWER HEADER	10
STEP 3. REMOVE SHIPPING STANDS	11
STEP 4. INSTALL REEL LIFT CYLINDERS	12
STEP 5. RE-POSITION GEARBOX	15
A. Filler Cap.....	16
STEP 6. INSTALL REEL SPEED SENSOR	17
A. REMOVE COVER.....	17
I. D60 HARVEST HEADER	17
II. D50 HARVEST HEADER	18
B. JOHN DEERE	19
I. D60 HARVEST HEADER	19
II. D50 HARVEST HEADER	20
C. LEXION 500 SERIES.....	22
I. D60 HARVEST HEADER	22
II. D50 HARVEST HEADER	24
D. LEXION 400 SERIES.....	25
I. D60 HARVEST HEADER	25
II. D50 HARVEST HEADER	26
E. AGCO SERIES	27
I. D60 HARVEST HEADER	27
II. D50 HARVEST HEADER	28
F. INSTALL COVER.....	29
I. D60 HARVEST HEADER	29
II. D50 HARVEST HEADER	29
STEP 7. INSTALL OPTIONS	29
STEP 8. SET UP ADAPTER	30
A. CENTER-LINK KIT	30
B. FLIGHTING EXTENSIONS.....	30
C. STRIPPER BARS	31
D. CR FEEDER DEFLECTORS	31
STEP 9. ATTACH TO COMBINE	32
A. CASE IH.....	32
B. CASE IH 23, 25 SERIES	35
C. JOHN DEERE 60 SERIES.....	38
D. JOHN DEERE 50 SERIES.....	40
E. CAT LEXION 400, 500 SERIES	42
F. NEW HOLLAND.....	46
G. AGCO.....	48
STEP 10. CONNECT REEL TO FORE-AFT CYLINDERS	51
STEP 11. ATTACH CAM ARMS	52

TABLE OF CONTENTS

STEP 12. INSTALL REEL ENDSHIELDS	53
STEP 13. REMOVE SHIPPING SUPPORTS	54
STEP 14. INSTALL CROP DIVIDERS	55
A. D60.....	55
B. D50.....	56
STEP 15. INSTALL HEADER ENDSHIELDS	57
A. HINGED ENDSHIELD.....	57
B. NON-HINGED ENDSHIELD	59
STEP 16. POSITION TRANSPORT LIGHTS	60
STEP 17. PRE-DELIVERY INSPECTION	61
A. TIRE PRESSURE (Transport and Stabilizer Wheel Options)	61
B. WHEEL BOLT TORQUE (Transport and Stabilizer Wheel Options).....	61
C. WOBBLE BOX	61
D. GEARBOX OIL.....	62
E. HYDRAULIC RESERVOIR	62
F. SICKLE DRIVE BELT TENSION	62
I. NON-TIMED DRIVE - SK and DK	62
II. TIMED DRIVE - DK	63
G. REEL CENTERING.....	64
H. SIDE DRAPER TENSION.....	65
I. HEADER MAIN FLOAT	66
J. SKID SHOE SETTINGS	68
K. REEL TINE TO CUTTERBAR CLEARANCE	69
L. DRAPER SEAL	70
M. LUBRICATE HEADER.....	71
N. MANUALS.....	75
STEP 18. RUN-UP THE HEADER	76
A. KNIFE SPEED	77
STEP 19. POST RUN-UP ADJUSTMENTS	78
A. KNIFE.....	78

GENERAL SAFETY



CAUTION

The following are general farm safety precautions that should be part of your operating procedure for all types of machinery.

Protect yourself:

- When assembling, operating and servicing machinery, wear all the protective clothing and personal safety devices that **COULD** be necessary for the job at hand. Don't take chances.
- You may need:

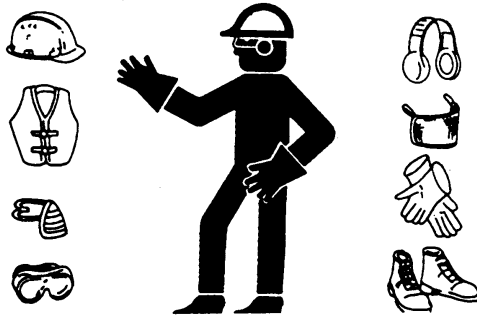

- a hard hat.
- protective shoes with slip resistant soles.
- protective glasses or goggles.
- heavy gloves.
- wet weather gear.
- respirator or filter mask.

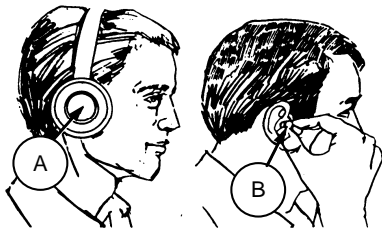

- hearing protection. Be aware that prolonged exposure to loud noise can cause impairment or loss of hearing. Wearing a suitable hearing protective device such as ear muffs (A) or ear plugs (B) protects against objectionable or loud noises.



- Provide a first-aid kit for use in case of emergencies.
- Keep a fire extinguisher on the machine. Be sure the extinguisher is properly maintained and be familiar with its proper use.
- Keep young children away from machinery at all times.
- Be aware that accidents often happen when the operator is tired or in a hurry to get finished. Take the time to consider the safest way. Never ignore warning signs of fatigue.
- Wear close-fitting clothing and cover long hair. Never wear dangling items such as scarves or bracelets.
- Keep hands, feet, clothing and hair away from moving parts. Never attempt to clear obstructions or objects from a machine while the engine is running.

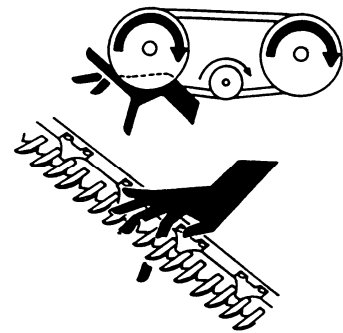

- Keep all shields in place. Never alter or remove safety equipment. Make sure driveline guards can rotate independently of the shaft and can telescope freely.

(continued next page)

SAFETY

- Use only service and repair parts made or approved by the equipment manufacturer. Substituted parts may not meet strength, design, or safety requirements.
- Do not modify the machine. Unauthorized modifications may impair the function and/or safety and affect machine life.
- Stop engine, and remove key from ignition before leaving Operator's seat for any reason. A child or even a pet could engage an idling machine.



- Keep the area used for servicing machinery clean and dry. Wet or oily floors are slippery. Wet spots can be dangerous when working with electrical equipment. Be sure all electrical outlets and tools are properly grounded.
- Use adequate light for the job at hand.
- Keep machinery clean. Do not allow oil or grease to accumulate on service platforms, ladders or controls. Clean machines before storage.
- Never use gasoline, naphtha or any volatile material for cleaning purposes. These materials may be toxic and/or flammable.
- When storing machinery, cover sharp or extending components to prevent injury from accidental contact.

RECOMMENDED TORQUES

RECOMMENDED TORQUES

A. GENERAL

The tables shown below give correct torque values for various bolts and capscrews.

- Tighten all bolts to the torques specified in chart unless otherwise noted throughout this manual.
- Check tightness of bolts periodically, using bolt torque chart as a guide.
- Replace hardware with the same strength bolt.
- Torque figures are valid for non-greased or non-oiled threads and heads unless otherwise specified. Do not grease or oil bolts or capscrews unless specified in this manual.
- When using locking elements, increase torque values by 5%.

B. SAE BOLTS

BOLT DIA. "A"	NC BOLT TORQUE*			
	SAE-5		SAE-8	
	ft-lbf	N-m	ft-lbf	N-m
1/4	9	12	11	15
5/16	18	24	25	34
3/8	32	43	41	56
7/16	50	68	70	95
1/2	75	102	105	142
9/16	110	149	149	202
5/8	150	203	200	271
3/4	265	359	365	495
7/8	420	569	600	813
1	640	867	890	1205

* Torque categories for bolts and capscrews are identified by their head markings.

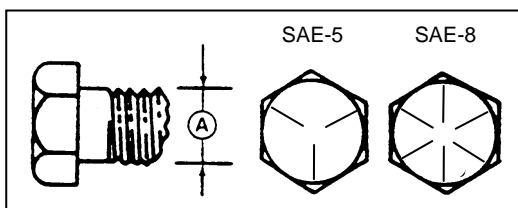

C. METRIC BOLTS

BOLT DIA. "A"	STD COARSE BOLT TORQUE*			
	8.8		10.9	
	ft-lbf	N-m	ft-lbf	N-m
M3	0.4	0.5	1.3	1.8
M4	2.2	3	3.3	4.5
M5	4	6	7	9
M6	7	10	11	15
M8	18	25	26	35
M10	37	50	52	70
M12	66	90	92	125
M14	103	140	148	200
M16	166	225	229	310
M20	321	435	450	610
M24	553	750	774	1050
M30	1103	1495	1550	2100
M36	1917	2600	2710	3675

* Torque categories for bolts and capscrews are identified by their head markings.

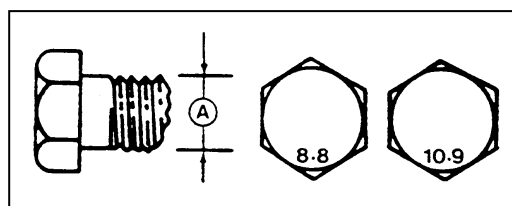

RECOMMENDED TORQUES

D. HYDRAULIC FITTINGS

FLARE TYPE

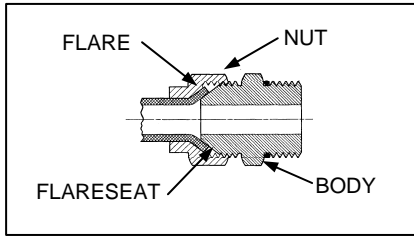

- Check flare and flare seat for defects that might cause leakage.
- Align tube with fitting before tightening.
- Lubricate connection, and hand-tighten swivel nut until snug.
- To prevent twisting the tube(s), use two wrenches. Place one wrench on the connector body, and with the second, tighten the swivel nut to the torque shown.

O-RING TYPE

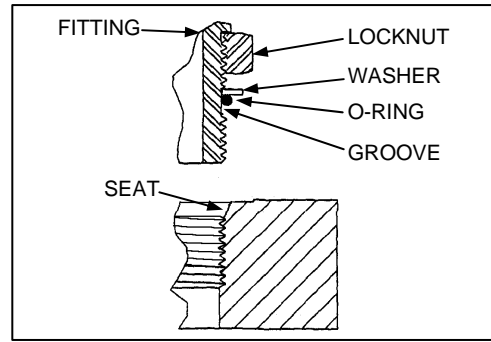

- Inspect O-ring and seat for dirt or obvious defects.

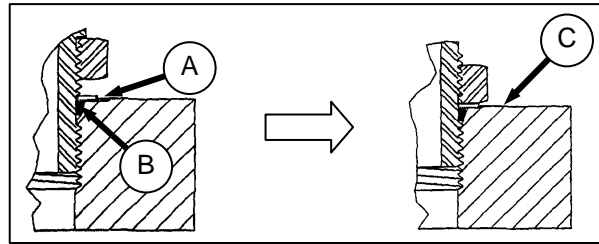

- On angle fittings, back off the lock nut until washer (A) "bottoms out" at top of groove (B) in fitting.
- Hand-tighten fitting until back-up washer (A), or washer face (if straight fitting), bottoms on part face (C), and O-ring is seated.
- Position angle fittings by unscrewing no more than one turn.
- Tighten straight fittings to torque shown.
- Tighten angle fittings to torque shown in the following table, while holding body of fitting with a wrench.

SAE NO.	TUBE SIZE O.D. (in.)	THD SIZE (in.)	NUT SIZE ACROSS FLATS (in.)	TORQUE VALUE*		RECOMMENDED TURNS TO TIGHTEN (AFTER FINGER TIGHTENING)	
				ft-lbf	N-m	Flats	Turns
3	3/16	3/8	7/16	6	8	1	1/6
4	1/4	7/16	9/16	9	12	1	1/6
5	5/16	1/2	5/8	12	16	1	1/6
6	3/8	9/16	11/16	18	24	1	1/6
8	1/2	3/4	7/8	34	46	1	1/6
10	5/8	7/8	1	46	62	1	1/6
12	3/4	1-1/16	1-1/4	75	102	3/4	1/8
14	7/8	1-3/8	1-3/8	90	122	3/4	1/8
16	1	1-5/16	1-1/2	105	142	3/4	1/8

* The torque values shown are based on lubricated connections as in re-assembly.

SAE NO.	THD SIZE (in.)	NUT SIZE ACROSS FLATS (in.)	TORQUE VALUE*		RECOMMENDED TURNS TO TIGHTEN (AFTER FINGER TIGHTENING)	
			ft-lbf	N-m	Flats	Turns
3	3/8	1/2	6	8	2	1/3
4	7/16	9/16	9	12	2	1/3
5	1/2	5/8	12	16	2	1/3
6	9/16	11/16	18	24	2	1/3
8	3/4	7/8	34	46	2	1/3
10	7/8	1	46	62	1-1/2	1/4
12	1-1/16	1-1/4	75	102	1	1/6
14	1-3/16	1-3/8	90	122	1	1/6
16	1-5/16	1-1/2	105	142	3/4	1/8
20	1-5/8	1-7/8	140	190	3/4	1/8
24	1-7/8	2-1/8	160	217	1/2	1/12

* The torque values shown are based on lubricated connections as in re-assembly.

RECOMMENDED TORQUES

O-RING FACE SEAL (ORFS) HYDRAULIC FITTINGS

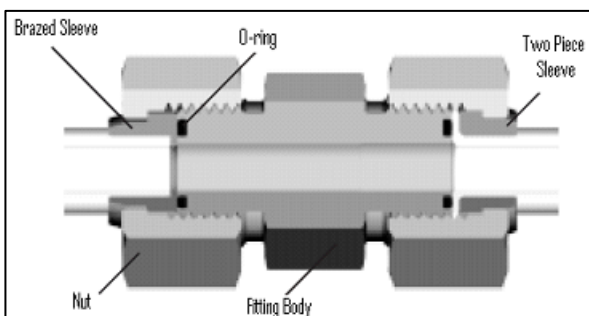
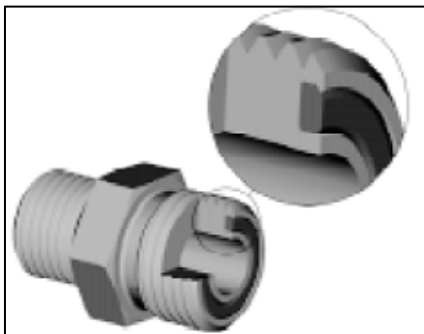

- a. Check components to ensure that the sealing surfaces and fitting threads are free of burrs, nicks, and scratches, or any foreign material.
- b. Apply lubricant (typically Petroleum Jelly) to O-ring and threads. If O-ring is not already installed, install O-ring. Align the tube or hose assembly.
- c. Ensure that flat face of the mating flange comes in full contact with O-ring.
- d. Thread tube or hose nut until hand-tight. The nut should turn freely until it is bottomed out. Torque fitting further to the specified number of F.F.F.T (“Flats From Finger Tight”), or to a given torque value in the table shown in the opposite column.

NOTE

If available, always hold the hex on the fitting body to prevent unwanted rotation of fitting body and hose when tightening the fitting nut.

- e. When assembling unions or two hoses together, three wrenches will be required.

SAE NO.	THD SIZE (in.)	TUBE O.D. (in.)	TORQUE VALUE*		RECOMMENDED TURNS TO TIGHTEN (AFTER FINGER TIGHTENING)**	
			ft-lbf	N-m	Tube Nuts	Swivel & Hose
3	***	3/16	---	---	---	---
4	9/16	1/4	11 - 12	14 - 16	1/4 - 1/2	1/2 - 3/4
5	***	5/16	---	---	---	---
6	11/16	3/8	18 - 20	24 - 27	1/4 - 1/2	1/2 - 3/4
8	13/16	1/2	32 - 35	43 - 47		
10	1	5/8	45 - 51	60 - 68		
12	1-3/16	3/4	67 - 71	90 - 95		
14	1-3/16	7/8	67 - 71	90 - 95	1/4 - 1/2	1/3 - 1/2
16	1-7/16	1	93 - 100	125 - 135		
20	1-11/16	1-1/4	126 - 141	170 - 190		
24	2	1-1/2	148 - 167	200 - 225	---	---
32	2-1/2	2	---	---	---	---

* Torque values and angles shown are based on lubricated connection, as in re-assembly.

** Always default to the torque value for evaluation of adequate torque.

*** O-ring face seal type end not defined for this tube size.

CONVERSION CHART

CONVERSION CHART

QUANTITY	INCH-POUND UNITS		FACTOR	SI UNITS (METRIC)	
	UNIT NAME	ABBR.		UNIT NAME	ABBR.
Area	acres	acres	$\times 0.4047 =$	hectares	ha
Flow	US gallons per minute	gpm	$\times 3.7854 =$	liters per minute	L/min
Force	pounds force	lbf	$\times 4.4482 =$	Newtons	N
Length	inch	in.	$\times 25.4 =$	millimeters	mm
	foot	ft	$\times 0.305 =$	meters	m
Power	horsepower	hp	$\times 0.7457 =$	kilowatts	kW
Pressure	pounds per square inch	psi	$\times 6.8948 =$	kilopascals	kPa
			$\times .00689 =$	megapascals	MPa
Torque	pound feet or foot pounds	lbf-ft or ft-lbf	$\times 1.3558 =$	newton meters	N·m
	pound inches or inch pounds	lbf-in. or in-lbf	$\times 0.1129 =$	newton meters	N·m
Temperature	degrees Fahrenheit	°F	$(^{\circ}\text{F} - 32) \times 0.56 =$	Celsius	°C
Velocity	feet per minute	ft/min	$\times 0.3048 =$	meters per minute	m/min
	feet per second	ft/s	$\times 0.3048 =$	meters per second	m/s
	miles per hour	mph	$\times 1.6063 =$	kilometers per hour	km/h
Volume	US gallons	US gal.	$\times 3.7854 =$	liters	L
	ounces	oz.	$\times 29.5735 =$	milliliters	ml
	cubic inches	in. ³	$\times 16.3871 =$	cubic centimeters	cm ³ or cc
Weight	pounds	lb	$\times 0.4536 =$	kilograms	kg

UNLOADING AND ASSEMBLY

STEP 1. UNLOAD HEADER



CAUTION

To avoid injury to bystanders from being struck by machinery, do not allow persons to stand in unloading area.



CAUTION

Equipment used for unloading must meet or exceed the requirements specified below. Using inadequate equipment may result in chain breakage, vehicle tipping or machine damage.

LIFTING VEHICLE	HEADER SIZE	
	15 - 25 FT	30 - 45 FT
Minimum Capacity *	6500 lb (2948 kg)	9000 lb (4082 kg)
Minimum Fork Length	78 in. (1981 mm)	

* At 48 in. (1220 mm) from back end of forks.

IMPORTANT

Forklifts are normally rated for a load located 24 inches (610 mm) from "back end" of the forks.

To obtain forklift capacity at 48 inches (1220 mm), check with your forklift distributor.

- Move trailer into position, and block trailer wheels.
- Lower trailer storage stands.



CAUTION

Avoid lifting the second header and ensure the forks do not interfere with the shipping frame. If the forks contact the second header, damage to the headers may occur.

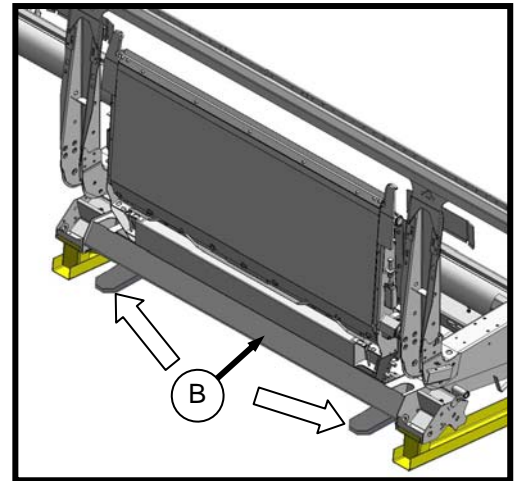

- Approach the header, and slide forks underneath shipping support (B) of header as far as possible without contacting the shipping support of opposite header.
- Remove hauler's tie down straps and chains.



WARNING

Be sure forks are secure before moving away from load. Stand clear when lifting.

- Slowly raise header off deck.
- Back up until unit clears trailer, and slowly lower to 6 in. (150 mm) from ground.
- Take header to storage or set up area.
- Repeat above steps for second header.
- Check for shipping damage and missing parts.

UNLOADING AND ASSEMBLY

STEP 2. LOWER HEADER

Re-position header in preparation for assembly and set-up as follows:

- Choose an area with level ground.
- Remove the endshields (if not already removed), as they may be damaged when lowering the header.
- Drive lifting vehicle to approach header from its "underside".

IMPORTANT

Do not lift at cutterbar when unloading from trailer. This procedure is only for laying the machine over into working position.

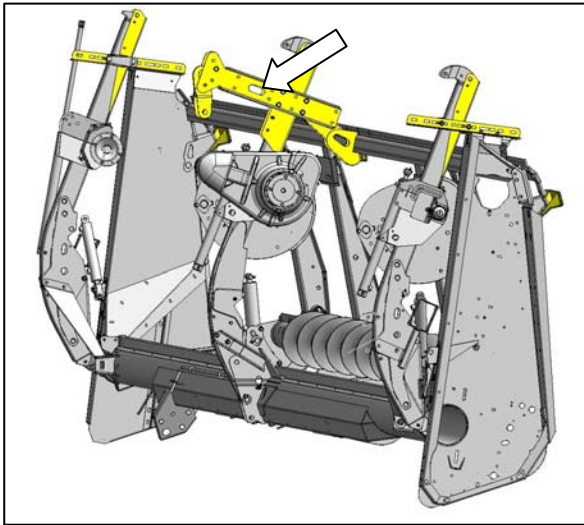

- Attach chain to shipping support at center reel arm.



CAUTION

Stand clear when lowering, as machine may swing.

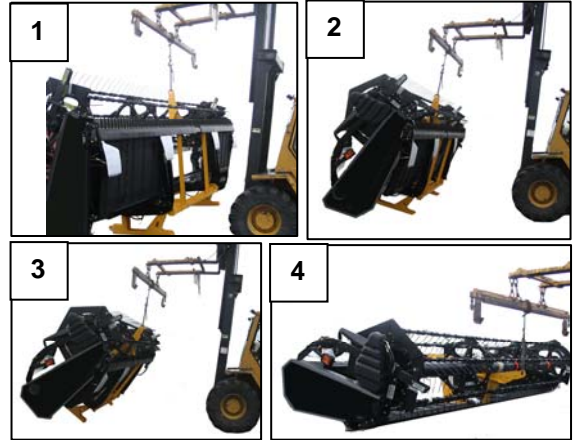

- Back up SLOWLY while lowering forks until header rests on the ground.



- Place 6 inch (150 mm) blocks under each end and center of cutterbar, and lower header onto blocks.
- Remove chain.

UNLOADING AND ASSEMBLY

STEP 3. REMOVE SHIPPING STANDS

The removable stands are painted yellow.

NOTE

Unless otherwise specified, discard stands, and all shipping material and hardware.

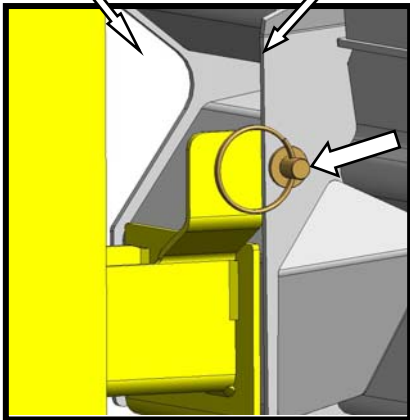
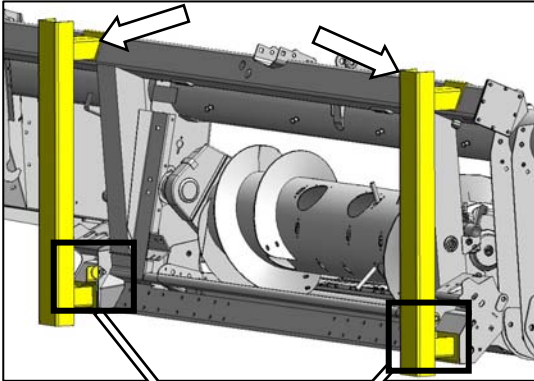

- a. Remove two pins at the base of each stand, and lift shipping stands off adapter.

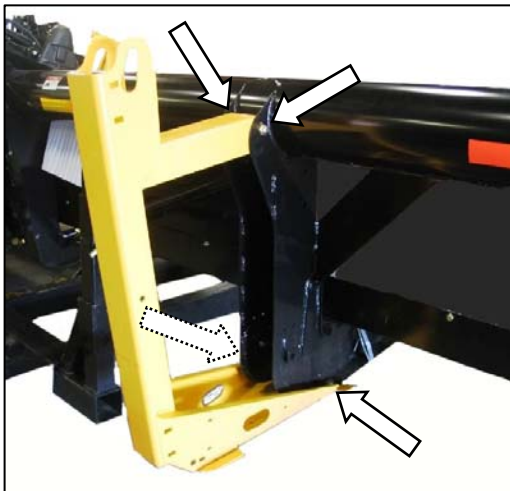

- b. Remove four bolts in each shipping stand on outboard header legs (30 FT headers and up), and remove stands.

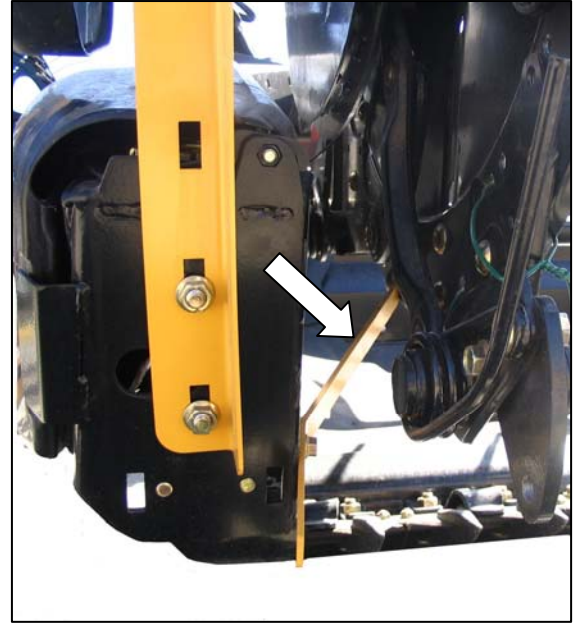

- c. Remove reel anti-rotation brace between reel and endsheet.

UNLOADING AND ASSEMBLY

STEP 4. INSTALL REEL LIFT CYLINDERS

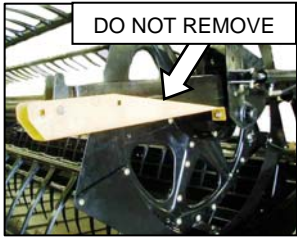

LH ARM - D60



RH ARM - D60



CENTER ARM - D60 DOUBLE REEL

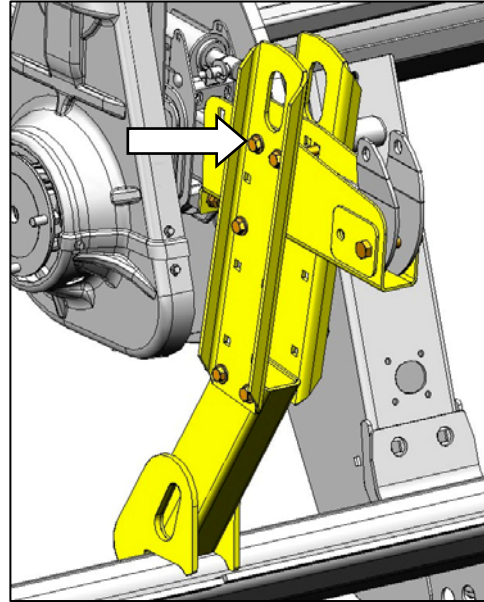

DOUBLE REEL SUPPORT

- b. Remove two top bolts on center reel arm support. (DOUBLE REEL ONLY).



CAUTION

Braces On Reel Arms Keep Reel From Sliding Forward. Do Not Remove.



D60 REEL SUPPORT

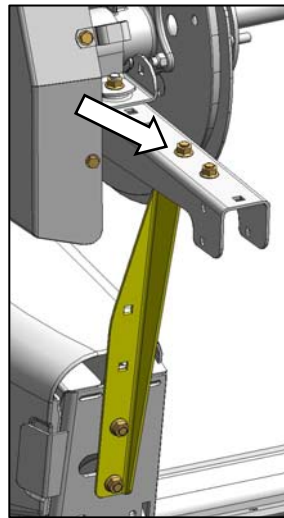

D50 REEL SUPPORT

- a. Remove top bolt on outboard reel arm supports.



D60 REEL SHOWN

- c. Position sling around the reel tube close to outboard end of reel, and attach sling to a forklift (or equivalent).
- d. Remove shipping wire/banding from cylinder, and remove pins from lug and arm.
- e. Lift reel so that reel lift cylinder mounting holes line up with lug on endsheet and hole in reel arm.

(continued next page)

UNLOADING AND ASSEMBLY

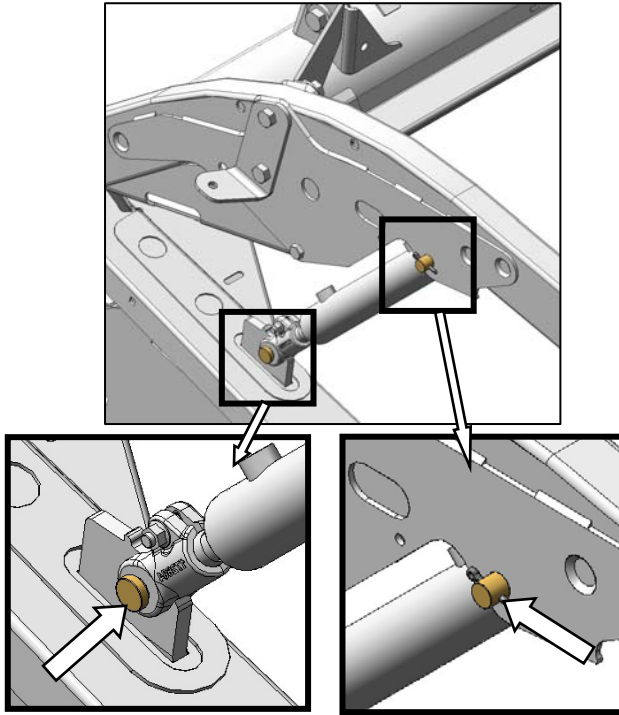

- f. Secure cylinder to endsheet and reel arm with pins as shown. Note orientation of pins. Secure with cotter pins.



DOUBLE REEL

- g. Remove sling and re-position around reel tube near reel center support arm. (DOUBLE REEL ONLY).
- h. Lift reel so that reel center lift cylinder mounting holes line up with bracket on frame. (DOUBLE REEL ONLY).
- i. Remove shipping wire/banding from cylinder, and remove pin from frame. (DOUBLE REEL ONLY).

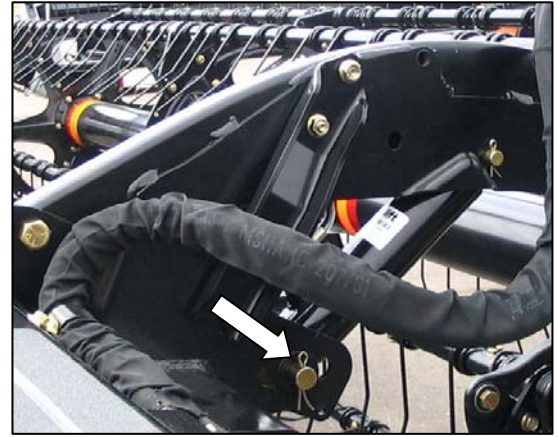

CENTER CYLINDER - DOUBLE REEL

- j. Attach cylinder to frame with pin as shown. Secure with cotter pin. (DOUBLE REEL ONLY).
- k. Remove sling, and re-position around reel tube near opposite outboard reel arm.
- l. Remove shipping wire/banding from cylinder, and remove pins from lug and arm.
- m. Lift reel so that reel lift cylinder mounting holes line up with lug on endsheet and hole in reel arm.

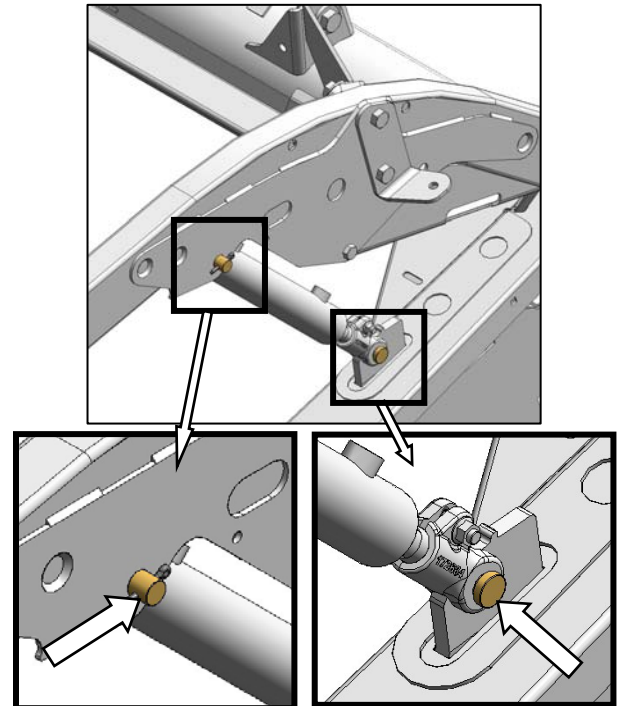

- n. Secure cylinder to endsheet and reel arm with pins as shown. Note orientation of pins. Secure with cotter pins.

(continued next page)

UNLOADING AND ASSEMBLY

- o. Remove shipping wire from center arm hose bundle, and remove bolt and nut from hose clip. (DOUBLE REEL ONLY).

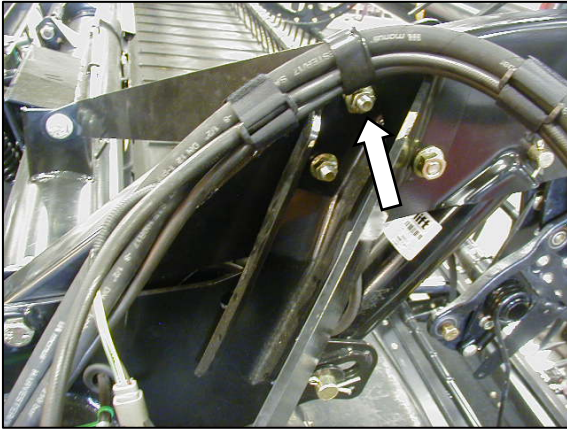

CENTER CYLINDER - DOUBLE REEL

- p. Re-install bolt with hose clip through upper hole in reel prop. (DOUBLE REEL ONLY).

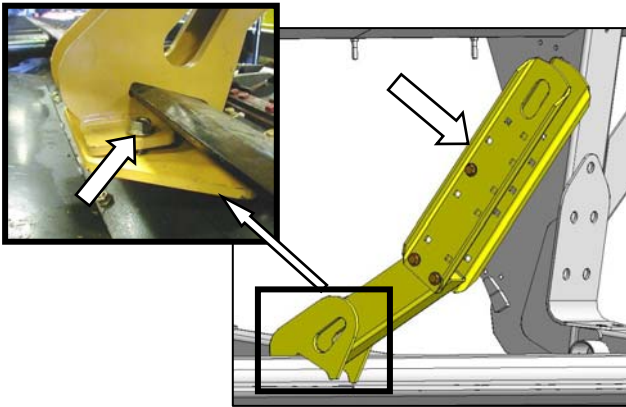

- q. Hold support, and remove two bolts at base of center reel arm shipping support so that plate drops free. (DOUBLE REEL).
- r. Slide lower support off cutterbar.

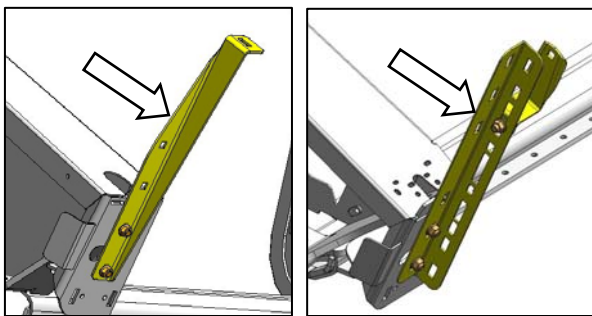

D50

D60

- s. Remove two reel arm supports from endsheets.



CAUTION

Braces On Reel Arms Keep Reel From Sliding Forward. Do Not Remove.

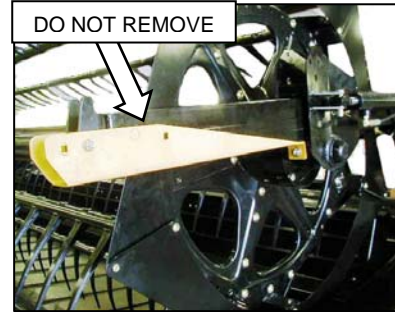

LH ARM - D60

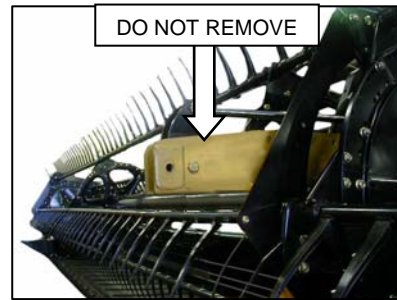

CENTER ARM - D60 DOUBLE REEL



RH ARM - D60

UNLOADING AND ASSEMBLY

STEP 5. RE-POSITION GEARBOX

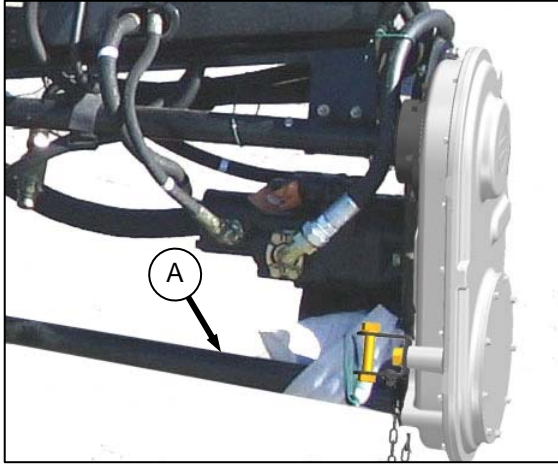

- a. Remove shipping wire and wrapping on brace, and swing brace (A) clear of gearbox.

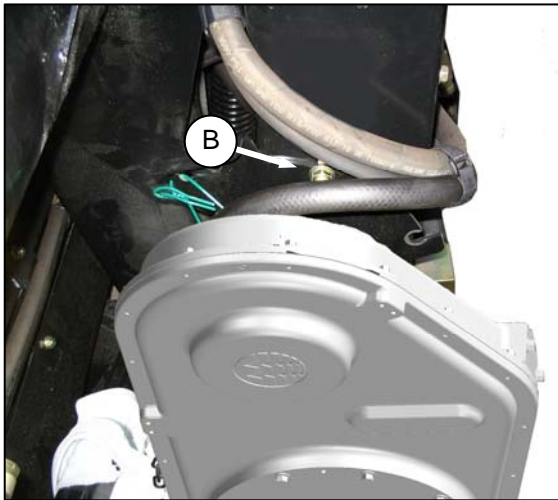

- b. Loosen nut (B), and move bolt out of shipping position slot.

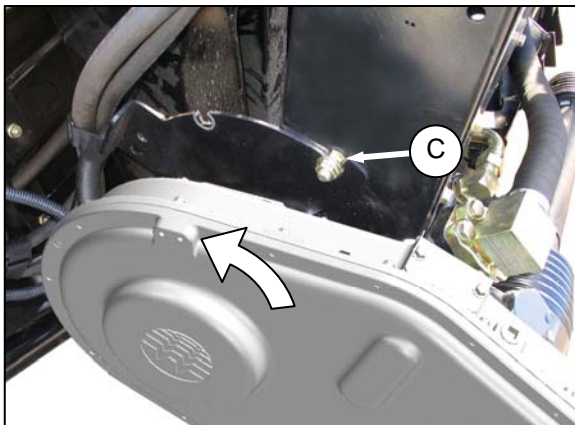

- c. Rotate gearbox, and move bolt into working position slot (C). Tighten nut.

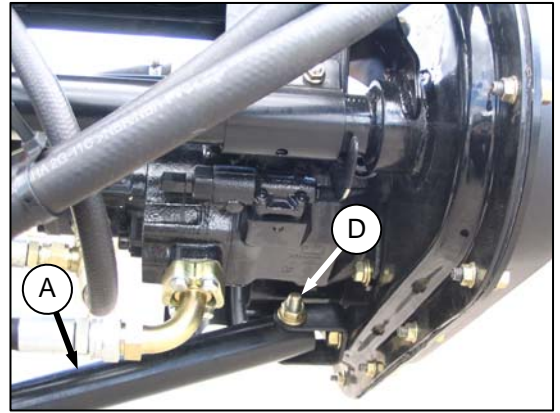

- d. Remove bolt (D) and nut from bracket on gearbox.
e. Position brace (A) inside bracket, and re-install bolt (D) and nut.

UNLOADING AND ASSEMBLY

A. FILLER CAP

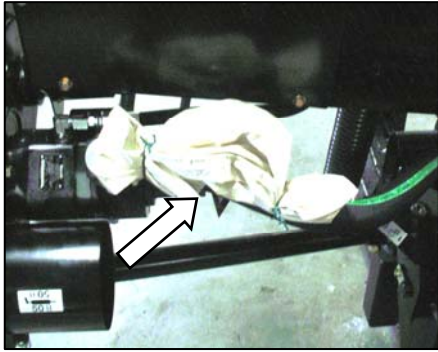

- a. Remove filler cap from bag.



- b. Remove yellow shipping cover (A) from adapter frame. Discard cover and keep screws.



CAUTION

Cap may be under pressure. Allow pressure to equalize by lifting cap slightly with some of the screws remaining.

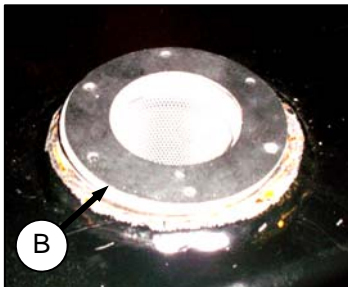

- c. There are two gaskets - one on either side of the filler strainer flange. Remove the top gasket (B) for use in step d.

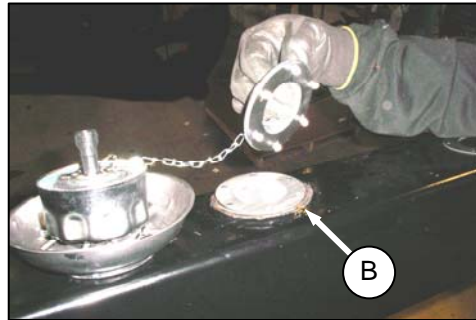

- d. Place gasket (B) that was removed from the top of the filler strainer onto filler cap neck, and align holes.
- e. Install #10-32 screws on filler cap, pressing screws through the gasket.
- f. Apply Loctite® #565 (or equivalent) to screws.
- g. Place filler cap (complete with screws) over opening, aligning the machine screws with the threaded holes.

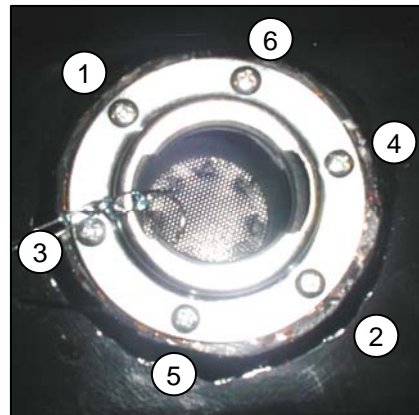

- h. Carefully thread in the machine screws using a cross pattern to prevent cross threading of tapped holes.
- i. Repeat pattern to gradually tighten screws to 31 lbf-in. (3.5 N-m).



- j. Install filler cap.

UNLOADING AND ASSEMBLY

STEP 6. INSTALL REEL SPEED SENSOR

NOTE

*This step is not applicable to CASE/CNH combines. Proceed to **STEP 7. INSTALL OPTIONS.***

IMPORTANT

Except for CAT Lexion combines, sensors are not supplied with MacDon Combine Adapters having Serial Numbers earlier than 177626_07. Sensors need to be purchased as per the following:

COMBINE	SENSOR PART NO.
JOHN DEERE - ALL	John Deere #AH116104 and Two Nuts #H104418
AGCO - ALL	AGCO #71 391 021



CAUTION

To avoid personal injury, before servicing header or opening drive covers:

- Fully lower the header. If necessary to service in the raised position, always engage lift cylinder stops.
- Stop engine and remove key.
- Engage park brake.

A. REMOVE COVER

I. D60 HARVEST HEADER

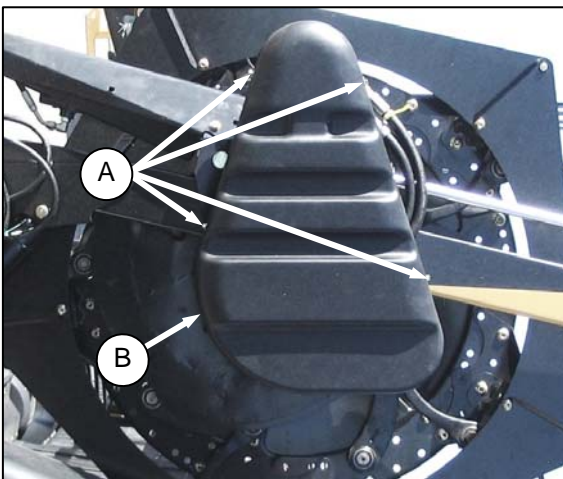

SINGLE REEL DRIVE

- a. For single reels, remove four screws (A), and remove cover (B).

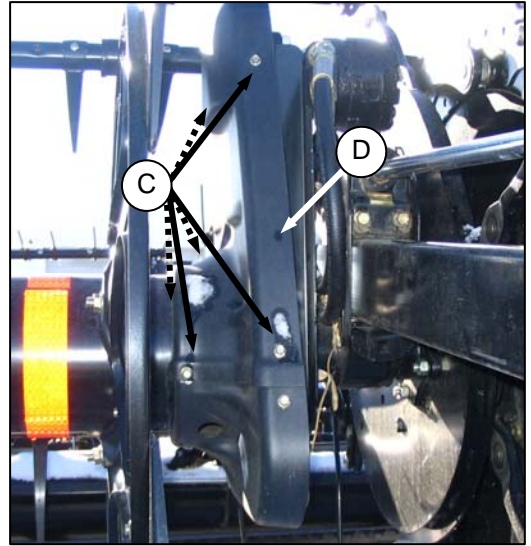

DOUBLE REEL DRIVE

- b. For double reels, remove six screws (C), and remove drive upper cover (D).

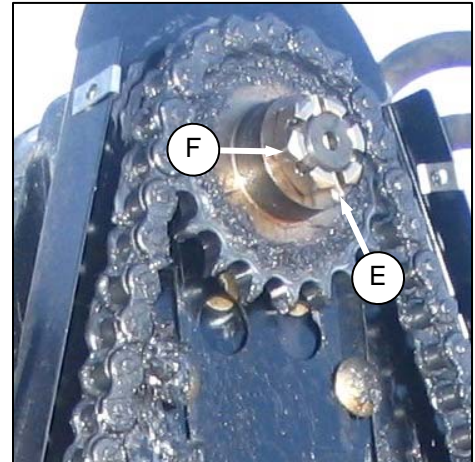

- c. Remove cotter pin (E), and remove slotted nut (F) from drive motor shaft.

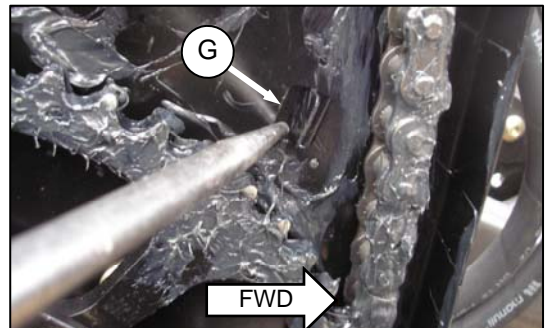

- d. Remove knock-out (G) in chain case for wire harness routing.

NOTE

Clean off grease to expose knock-out.

(continued next page)

UNLOADING AND ASSEMBLY

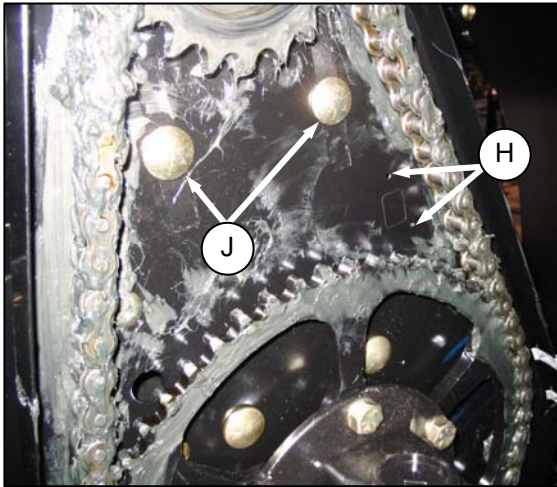

- e. If necessary, clean up holes (H) with a 0.125 in. (3.2 mm) drill.
- f. Remove bolts (J) in chain case.

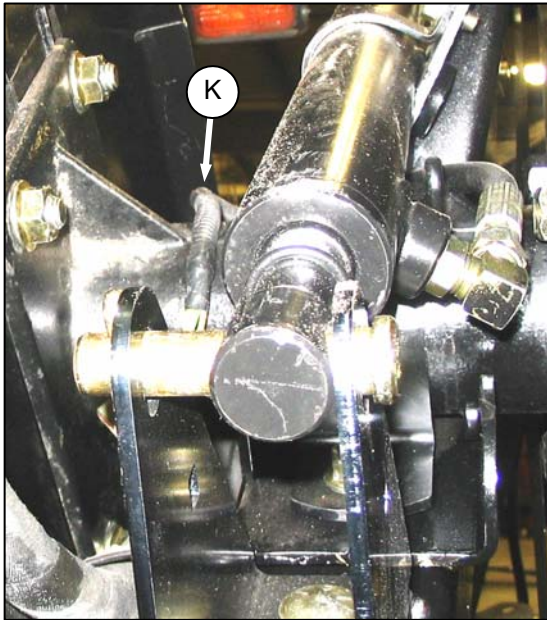

- g. Retrieve existing harness (K) from reel arm.

NOTE

Harness may be stored inside hose cover on top of reel arm.

- h. Proceed to procedure B, C, D or E for your particular combine.

II. D50 HARVEST HEADER

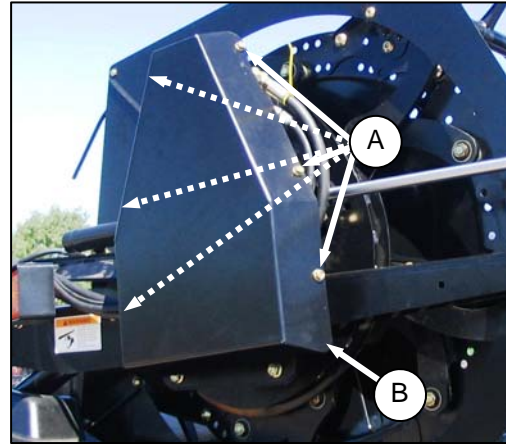

- a. Remove six screws (A), and remove cover (B).

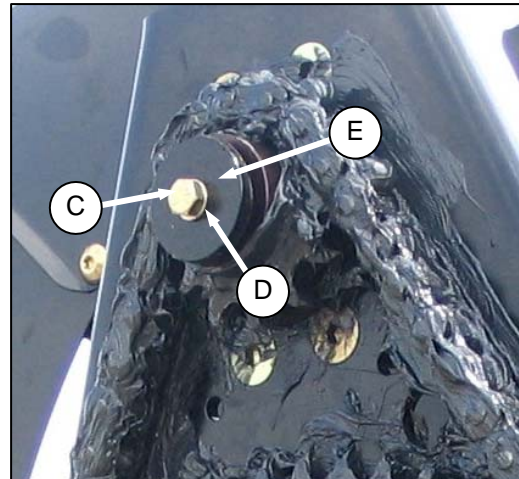

- b. Remove bolt (C), lockwasher (D), and flat washer (E).



- c. Retrieve existing harness (F) from reel arm.
- d. Proceed to procedure B, C, D or E for your particular combine.

UNLOADING AND ASSEMBLY

B. JOHN DEERE

I. D60 HARVEST HEADER

- a. Perform **A. REMOVE COVER**.
- b. Retrieve speed sensor kit from combine completion package.



- c. Position speed sensor disc (A) on shaft, and re-install slotted nut (B). Torque to 10 - 20 in-lbf (1.1 - 2.2 N-m).
- d. Install cotter pin (C). Tighten nut to next slot if required.

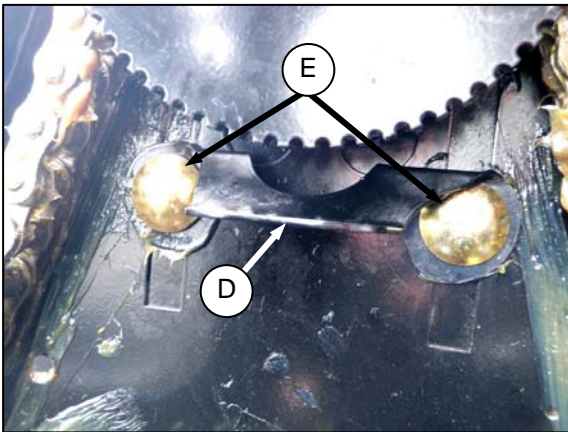

- e. Locate bracket (D) on chain case, and re-install bolts (E). Torque to 75 ft-lbf (102 N-m).

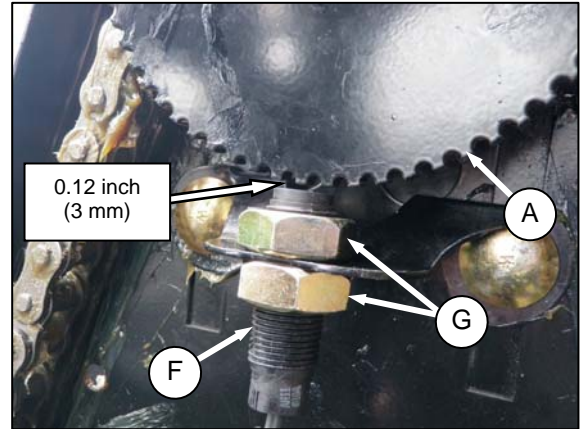

- f. Locate sensor (F) in bracket, and adjust gap between sensor and disc (A) to 0.12 in. (3 mm) with nuts (G). Tighten nuts.

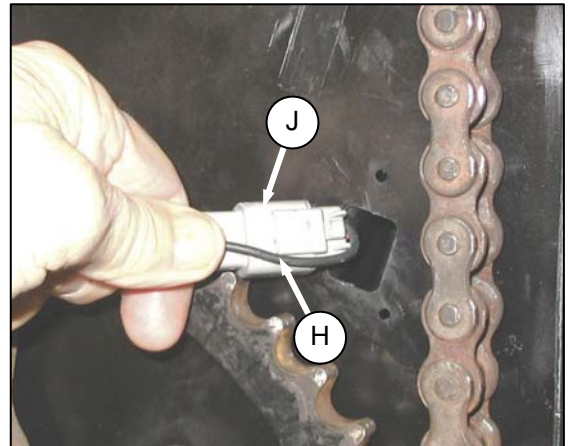

- g. Locate black wire (H) against harness connector (J) as shown, and feed connector through hole in chain case.

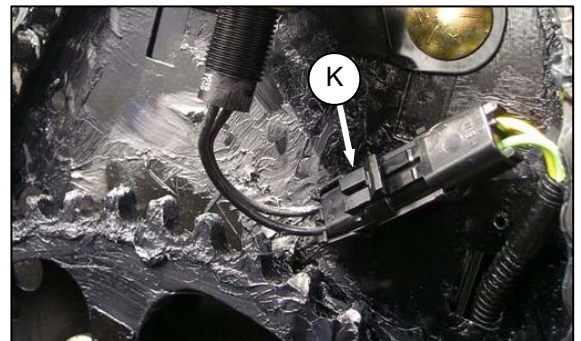

- h. Connect other end to sensor connector (K).
(continued next page)

UNLOADING AND ASSEMBLY

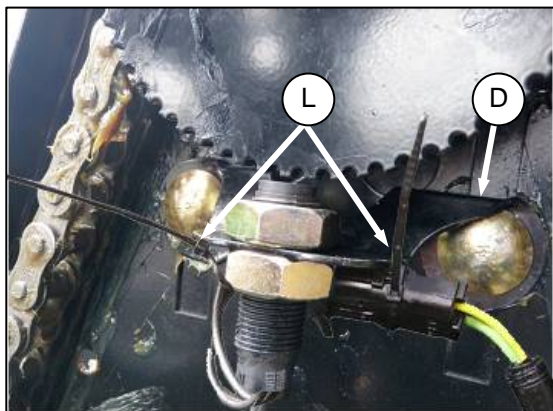

- i. Secure harness to support (D) with two cable ties (L).

IMPORTANT

Ensure harness is clear of chain and sprockets, and that motor can be moved up and down fully in slots without damaging harness.

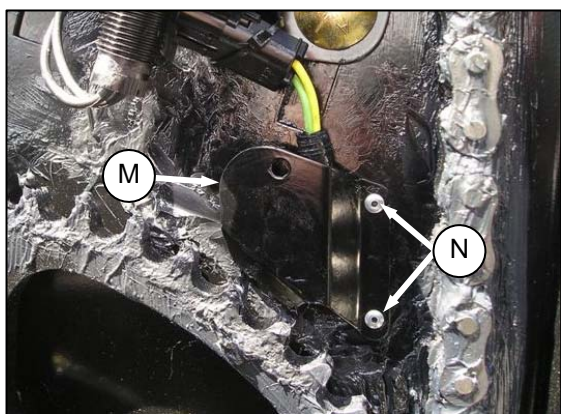

- j. Locate cover (M) over harness, and attach to chain case with two rivets (N).
k. Perform **F. INSTALL COVER.**

II. D50 HARVEST HEADER

- a. Perform **A. REMOVE COVER.**
b. Retrieve speed sensor kit from combine completion package.

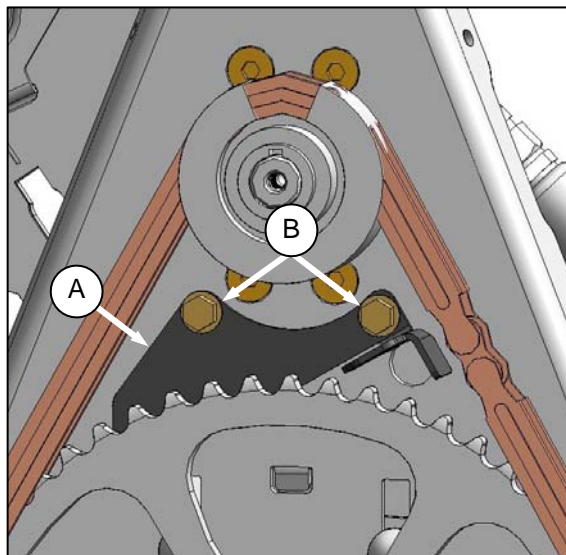

- c. Locate sensor holder (A) on reel drive case, and secure with two 3/8 in. x 0.62 long self-tapping screws (B) in existing holes in drive case.

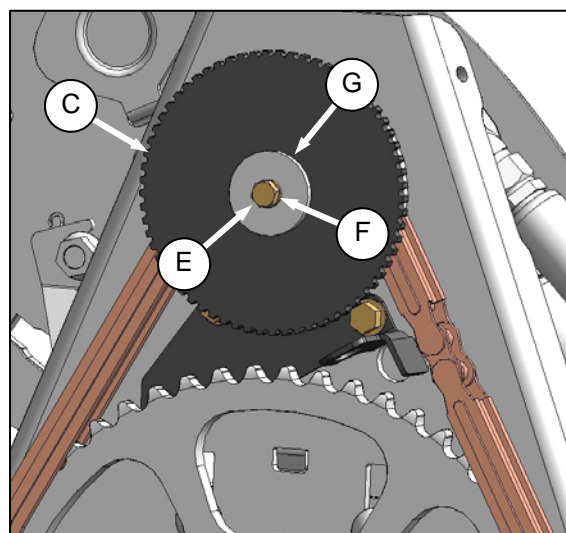

- d. Install sensor disc (C) onto drive sprocket with bolt (E), lockwasher (F), and flat washer (G).
e. Torque bolt to 18 ft·lbf (24 N·m).

(continued next page)

UNLOADING AND ASSEMBLY

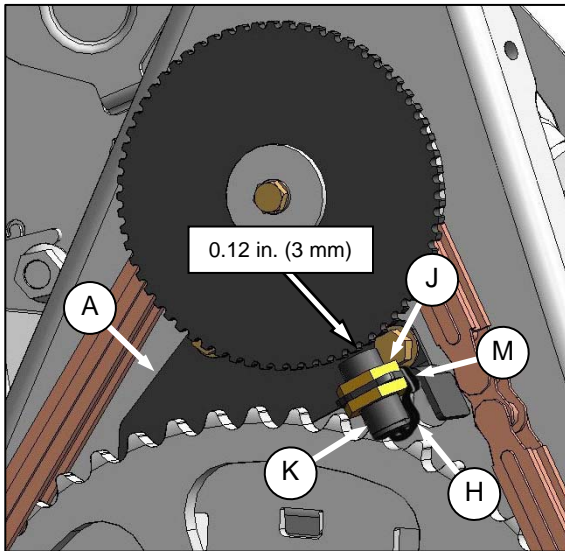

- f. Route sensor harness (H) through hole in drive case as shown.
- g. Remove jam-nut (J) on sensor, and install sensor (K) in holder (A). Install jam-nut. Adjust gap between sensor and sensor disc using jam-nuts. Gap should be 0.12 in. (3 mm). Tighten jam-nuts.
- h. Secure wires to support (A) with plastic cable tie (M). Route tie behind sensor.
- i. Perform **F. INSTALL COVER**.

UNLOADING AND ASSEMBLY

C. LEXION 500 SERIES

I. D60 HARVEST HEADER

- a. Perform A. REMOVE COVER.
- b. Retrieve speed sensor kit from combine completion package.

IMPORTANT

Steps c. and d. are required to establish the amount of slack in the harness, and to determine the harness location on the cover, so that when the chain (A) is loosened, the harness or sensor will not be damaged.

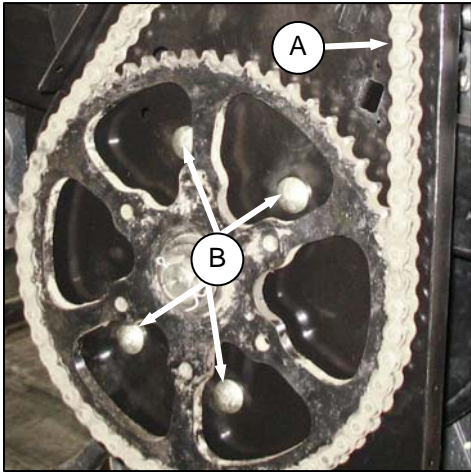

- c. Loosen four bolts (B)

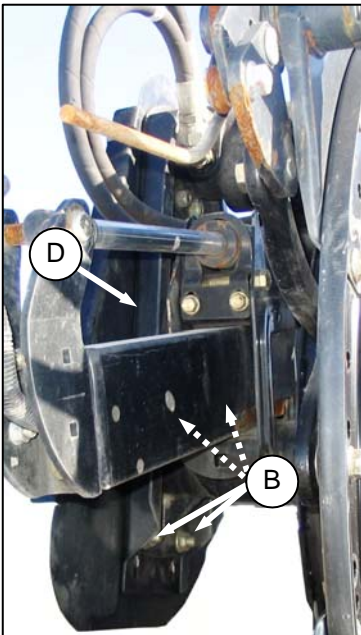

- d. Loosen drive chain (A) by sliding motor mount (D) "down" towards reel shaft.

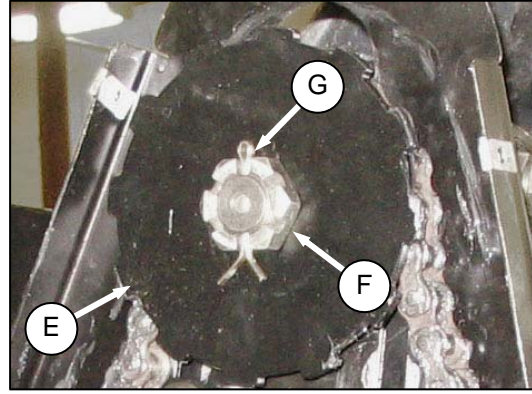

- e. Position speed sensor disc (E) on shaft and re-install slotted nut (F). Torque to 10 - 20 in-lbf (1.1 - 2.2 N-m).
- f. Install cotter pin (G). Tighten nut to next slot if required.

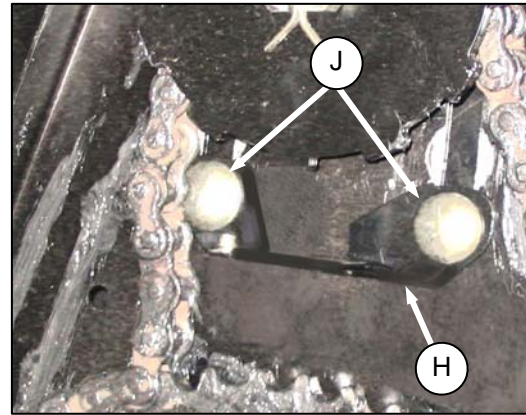

- g. Locate support (H) on chain case and re-install bolts (J). Torque to 75 ft-lbf (102 N-m).

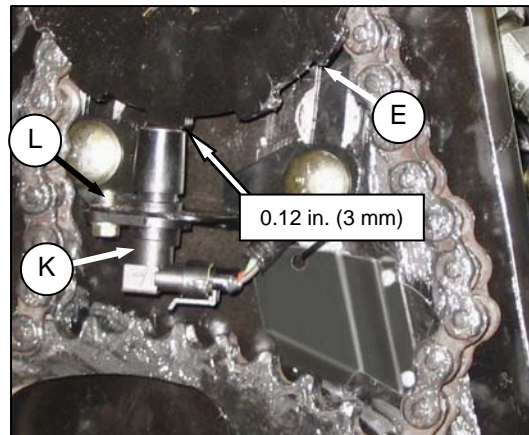

- h. Locate sensor (K) in support (H), and adjust gap between sensor and disc (E) to 0.12 in. (3 mm) by bending support. After gap is achieved, secure sensor with ¼ in. x 0.5 long self-tapping screw (L).

(continued next page)

UNLOADING AND ASSEMBLY

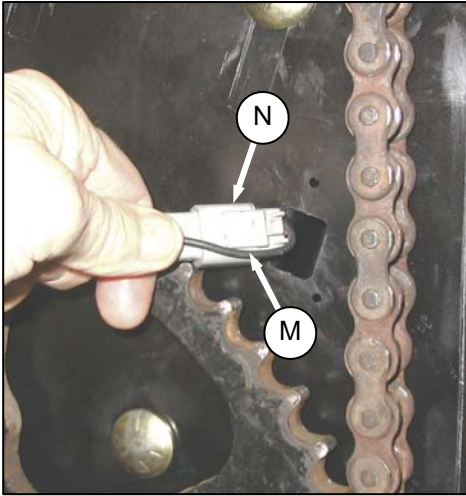

- i. Locate black wire (M) against harness connector (N) as shown, and feed connector through hole in chain case.

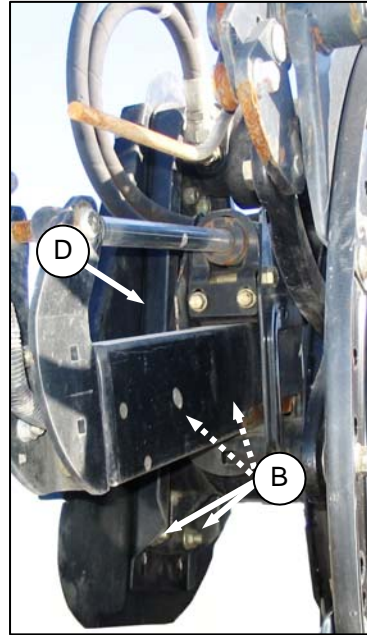

- m. Tighten drive chain by motor mount (D) "up" away from reel shaft. Hand force should deflect the chain 1/8 in. (3 mm).

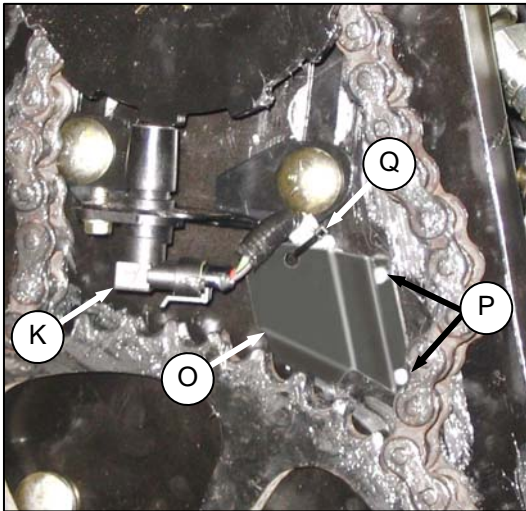

- j. Connect other end to sensor (K).
- k. Locate cover (O) over harness, and attach to chain case with two rivets (P).
- l. Secure harness to cover (O) with cable tie (Q) exactly as shown.

IMPORTANT

Ensure harness is clear of chain and sprockets, and that motor can be moved up and down fully in slots without damaging harness.

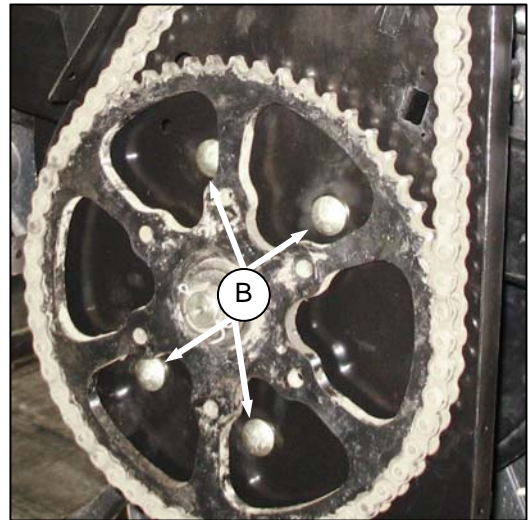

- n. Tighten bolts (B) to 75 ft·lbf (1 02 N·m).
- o. Perform **F. INSTALL COVER.**

UNLOADING AND ASSEMBLY

II. D50 HARVEST HEADER

- a. Perform **A. REMOVE COVER.**
- b. Retrieve speed sensor kit from combine completion package.

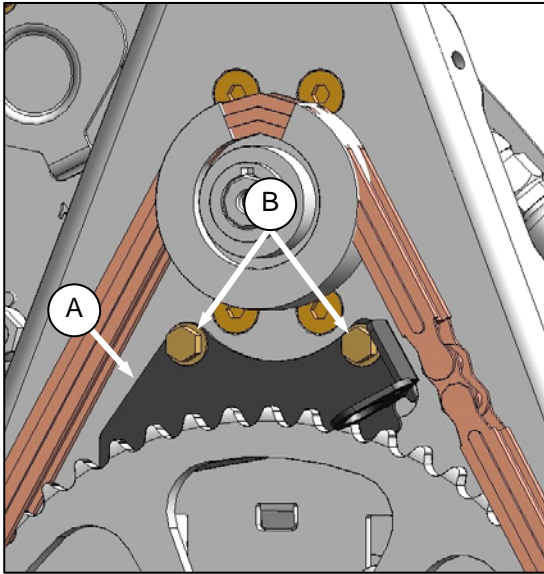

- c. Locate sensor holder (A) on reel drive case, and secure with two 3/8 in. x 0.62 long self-tapping screws (B). Do not fully tighten.

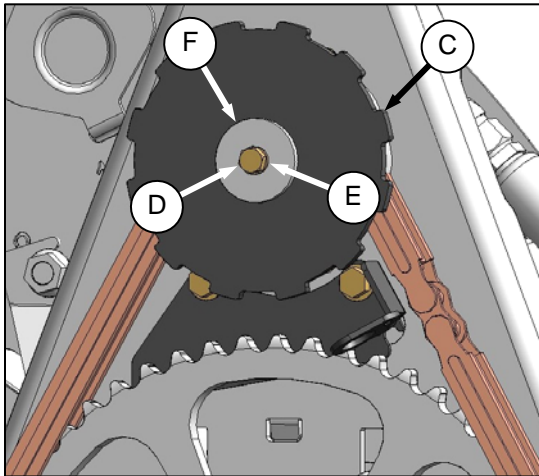

- d. Install sensor disc (C) onto drive sprocket with bolt (D), lockwasher (E), and flat washer (F).
- e. Torque bolt to 18 ft·lbf (24 N·m).

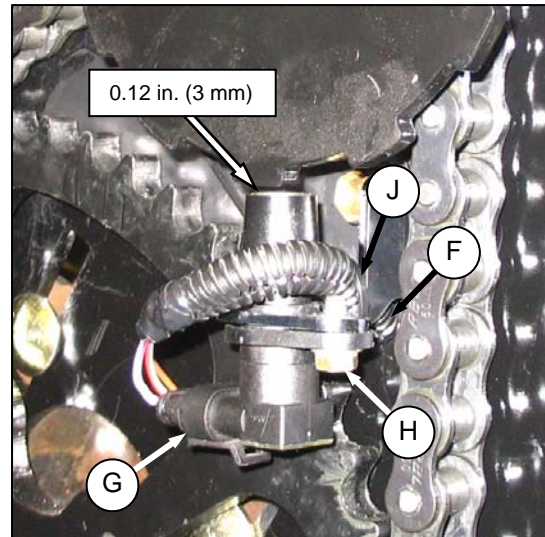

- f. Route sensor harness (F) through holder and drive case as shown.
- g. Assemble sensor (G) to holder (A) with self-tapping screw (H).
- h. Secure harness to holder (A) with plastic cable tie (J).
- i. Adjust gap between sensor and disc to 0.12 in. (3 mm) by moving sensor holder (A). Tighten screws after gap is set.
- j. Perform **F. INSTALL COVER.**

UNLOADING AND ASSEMBLY

D. LEXION 400 SERIES

I. D60 HARVEST HEADER

- a. Perform **A. REMOVE COVER.**
- b. Retrieve speed sensor kit from combine completion package.

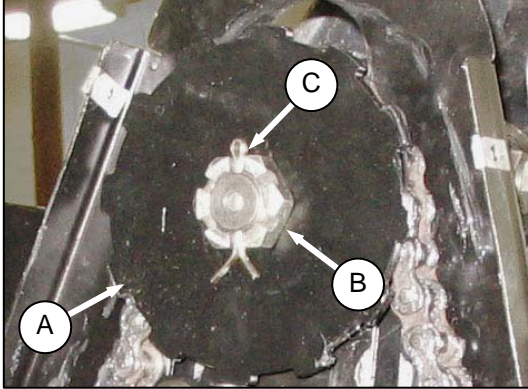

- c. Position speed sensor disc (A) on shaft, and re-install slotted nut (B). Torque to 10 - 20 in-lbf (1.1 - 2.2 N-m).
- d. Install cotter pin (C). Tighten nut to next slot if required.

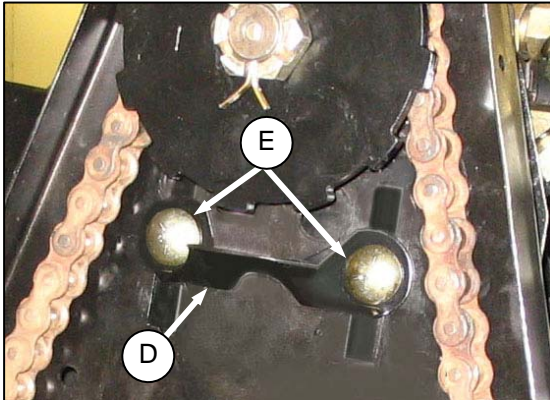

- e. Locate bracket (D) on chain case, and re-install bolts (E). Torque to 75 ft-lbf (102 N-m).

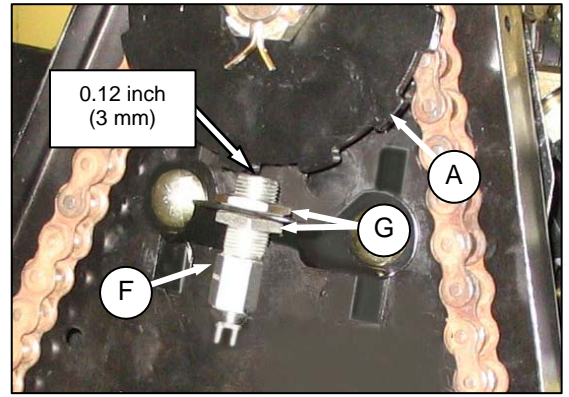

- f. Locate sensor (F) in bracket, and adjust gap between sensor and disc (A) to 0.12 in. (3 mm) with nuts (G). Tighten nuts.

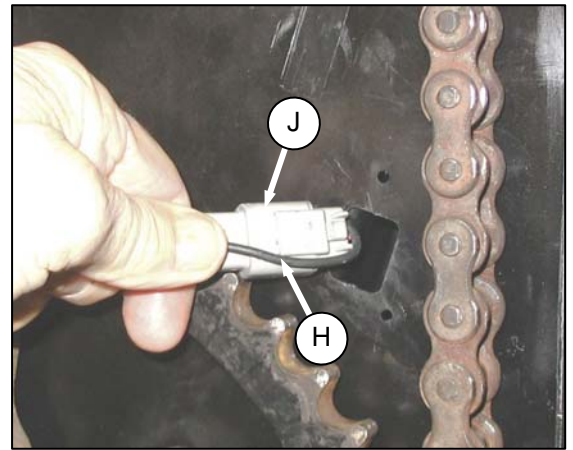

- g. Locate black wire (H) against harness connector (J) as shown, and feed connector through hole in chain case.

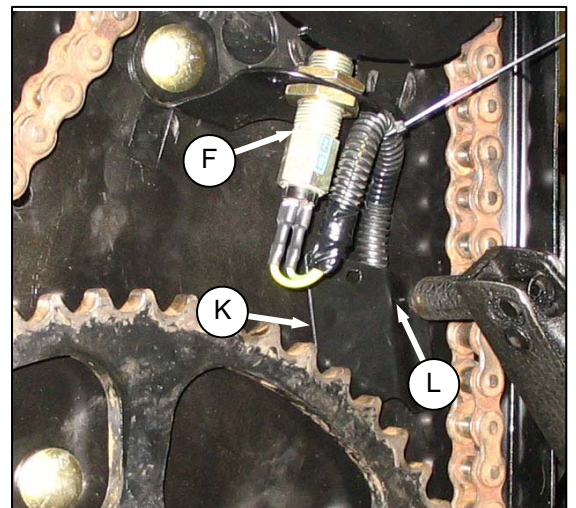

- h. Connect other end to sensor (F).
- i. Locate cover (K) over harness, and attach to chain case with two rivets (L).

(continued next page)

UNLOADING AND ASSEMBLY

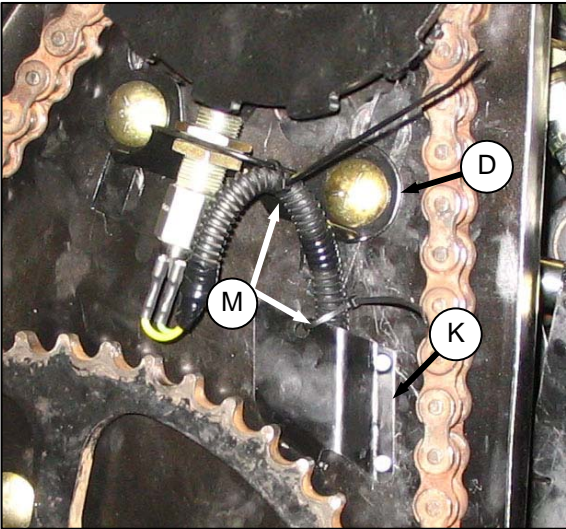

- j. Secure harness to support (D) and cover (K) with cable ties (M).

IMPORTANT

Ensure harness is clear of chain and sprockets, and that motor can be moved up and down fully in slots without damaging harness.

- k. Perform **F. INSTALL COVER.**

II. D50 HARVEST HEADER

- a. Perform **A. REMOVE COVER.**
 b. Retrieve speed sensor kit from combine completion package.

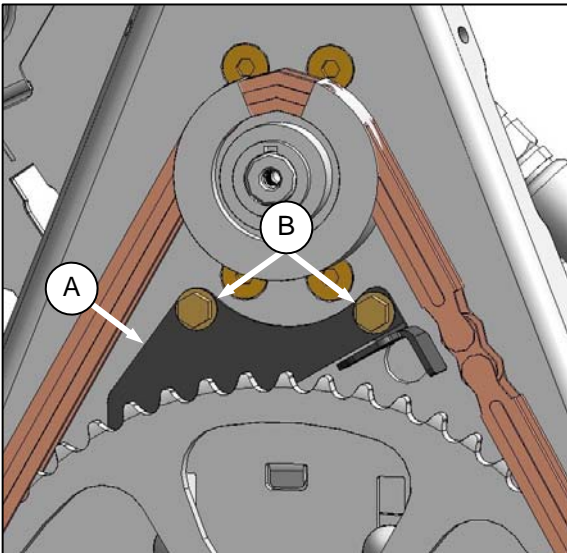

- c. Locate sensor holder (A) on reel drive case, and secure with two 3/8 in. x 0.62 long self-tapping screws (B). Do not fully tighten.

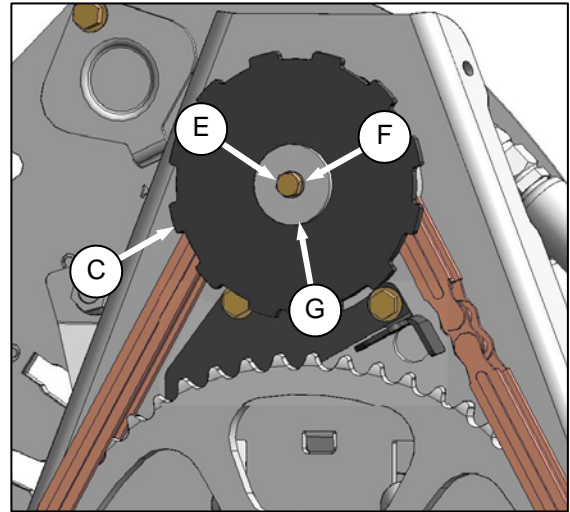

- d. Install sensor disc (C) onto drive sprocket with bolt (E), lockwasher (F), and flat washer (G). Torque bolt to 18 ft-lbf (24 N-m).

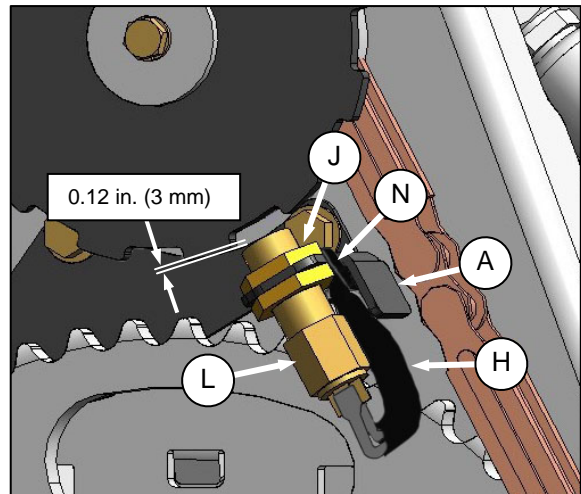

- e. Route sensor harness (H) through holder and drive case as shown.
 f. Remove jam-nut (J) on sensor, and install sensor (L) in holder (A). Install jam-nut.
 g. Secure harness (H) to holder (A) with plastic cable tie (N). Route plastic tie behind sensor (L).
 h. Adjust gap between sensor and sensor disc using jam-nuts. Gap should be 0.12 in. (3 mm). Tighten jam-nuts.
 i. Perform **F. INSTALL COVER.**

UNLOADING AND ASSEMBLY

E. AGCO SERIES

I. D60 HARVEST HEADER

- Perform **A. REMOVE COVER.**
- Retrieve speed sensor kit from combine completion package.

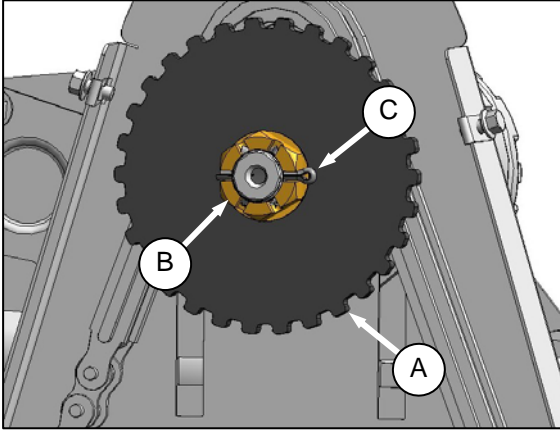

- Position speed sensor disc (A) on shaft, and re-install slotted nut (B). Torque to 10 - 20 in-lbf (1.1 - 2.2 N-m).
- Install cotter pin (C). Tighten nut to next slot if required.

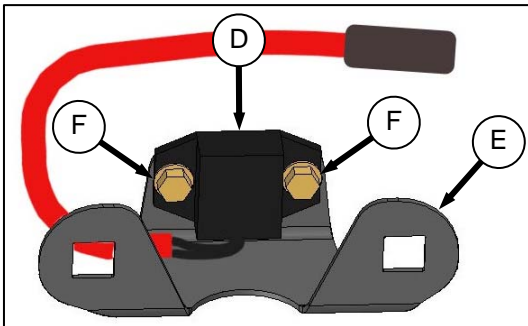

- Assemble sensor (D) to support (E) with self-tapping screws (F).



2-WIRE SENSOR



3-WIRE SENSOR

NOTE

Install 2-wire sensor for Gleaner R and S Series combines. Install 3-wire sensor for all other AGCO models.

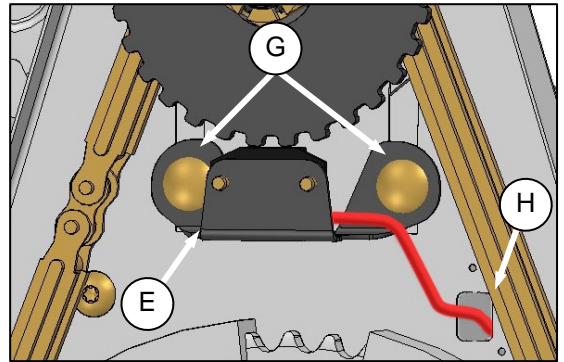

- Locate support (E) on chain case, and re-install bolts (G). Torque to 75 ft-lbf (102 N-m).
- Route connector end of sensor harness through hole (H) in drive case as shown.

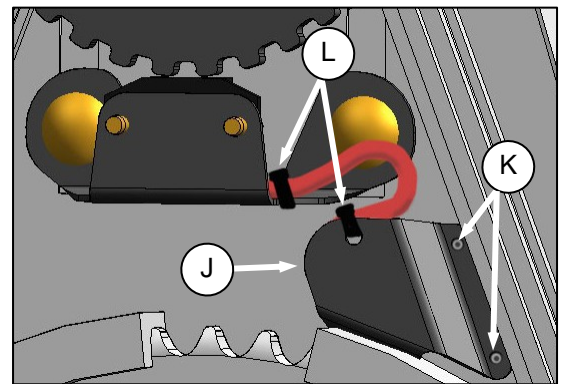

- Locate cover (J) over harness, and attach to chain case with two rivets (K).
- Secure harness to cover (K) and support with cable ties (L) exactly as shown.

IMPORTANT

Ensure harness is clear of chain and sprockets, and that motor can be moved up and down fully in slots without damaging harness.

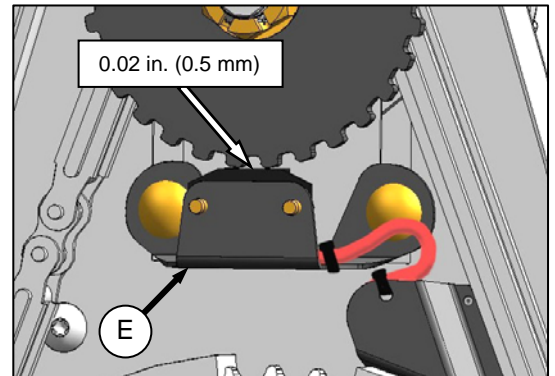

- Adjust gap between sensor and disc to 0.02 inch (0.5 mm) by bending support (E).

UNLOADING AND ASSEMBLY

II. D50 HARVEST HEADER

- a. Perform **A. REMOVE COVER.**
- b. Retrieve speed sensor kit from combine completion package.

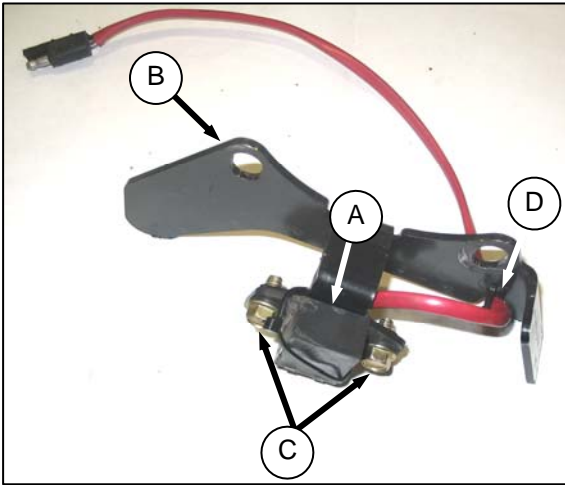

- c. Assemble sensor (A) to holder (B) with self-tapping screws (C).



2-WIRE SENSOR



3-WIRE SENSOR

NOTE

Install 2-wire sensor for Gleaner R and S Series combines. Install 3-wire sensor for all other AGCO models.

- d. Secure wire to holder with plastic cable tie (D).

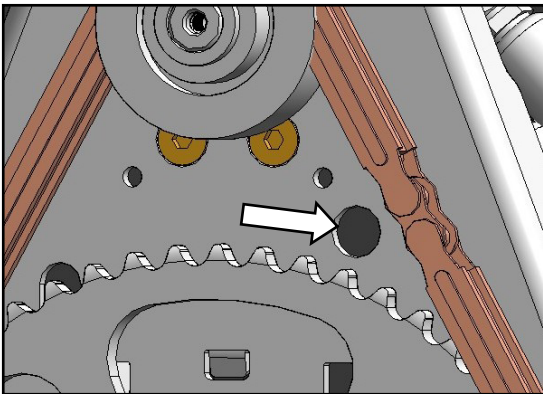

- e. Route connector end of sensor harness through hole in drive case (as shown).

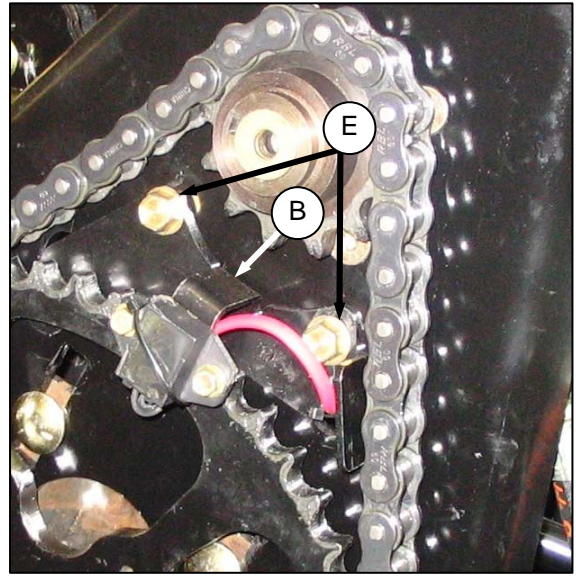

- f. Locate sensor holder (B) on reel drive case, and secure with two 3/8 in. x 0.62 long self-tapping screws (E). Do not fully tighten.

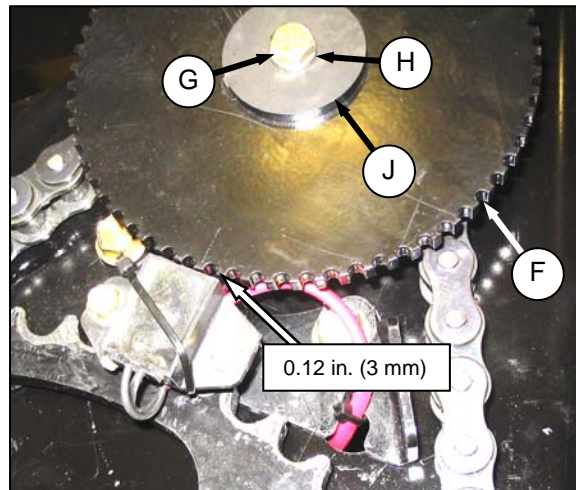

- g. Install sensor disc (F) onto drive sprocket with bolt (G), lockwasher (H), and flat washer (J). Torque bolt to 18 ft-lbf (24 N·m).
- h. Adjust gap between sensor and disc to 0.12 in. (3 mm) by moving sensor holder (B). Tighten screws (E) after gap is set.
- i. Perform **F. INSTALL COVER.**

UNLOADING AND ASSEMBLY

F. INSTALL COVER

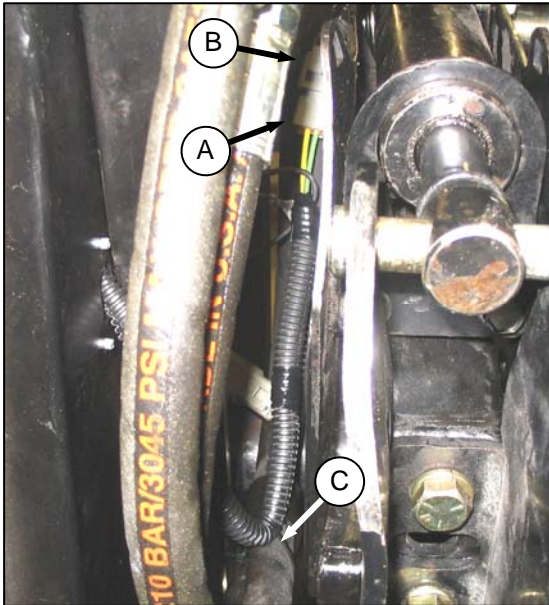

- Attach sensor connector (A) to existing harness (B) behind chain case.
- Secure sensor harness to hose with cable tie (C).
- Install cover as follows (depending on your particular header):

I. D60 HARVEST HEADER

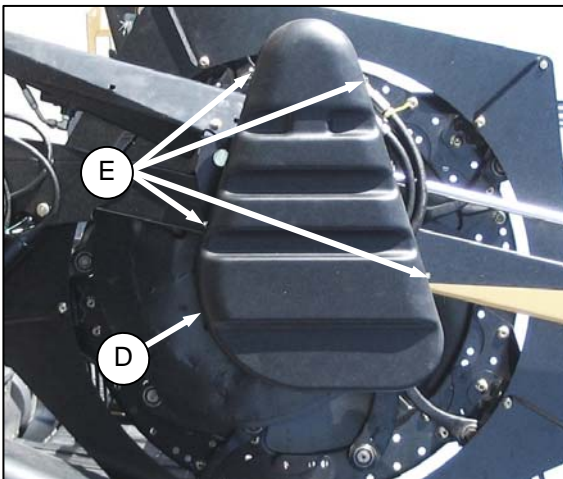

SINGLE REEL DRIVE

- For single reels, position cover (D), and install four screws (E).

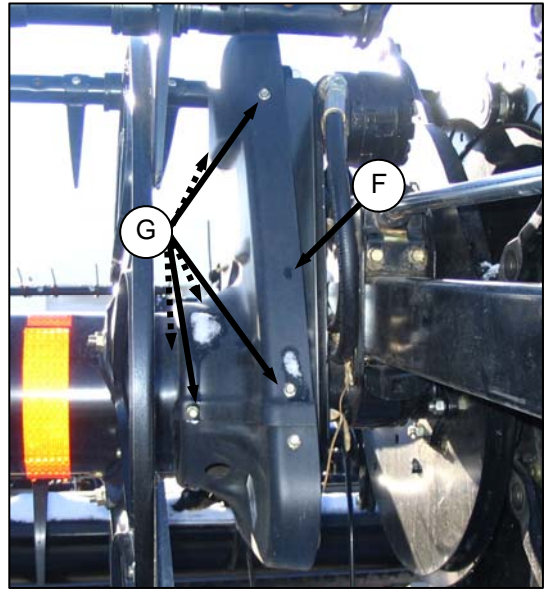

DOUBLE REEL DRIVE

- For double reels, position cover (F), and install six screws (G).

II. D50 HARVEST HEADER

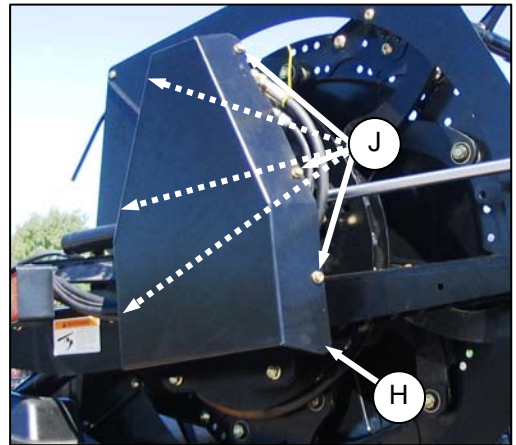

- Position cover (H), and install six screws (J).

STEP 7. INSTALL OPTIONS

Retrieve kits supplied as options with the header, and install in accordance with installation instructions supplied in each kit.

UNLOADING AND ASSEMBLY

STEP 8. SET UP ADAPTER

A. CENTER-LINK KIT

Some combine models require shorter center-link components to ensure clearance to the combine cab.

To avoid damage to your combine, lift feeder slowly, and check clearance between cab and header center-link.

If clearance is inadequate, order short center-link components. Installation instructions are included.

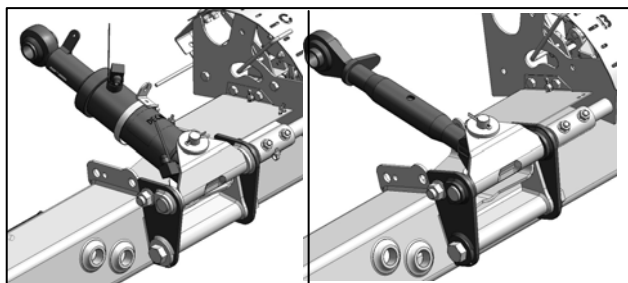

SHORT CENTER-LINK ASSEMBLIES

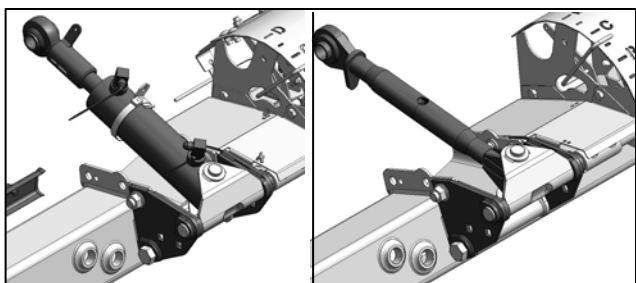

TYPICAL CENTER-LINK ASSEMBLIES

The following combine models have been identified as requiring the short center-link components:

- Case IH 5088, 6088, and 7088 without Stone Traps.
- Gleaner R Series.

B. FLIGHTING EXTENSIONS

Flighting extension kits may have been supplied with your header to improve feeding in certain crops such as rice. They are not recommended in cereal crops.

APPLICABLE COMBINES: All except New Holland CR960, 9060, 970, 9070, and 9080.

If necessary, remove auger flighting extensions as follows.

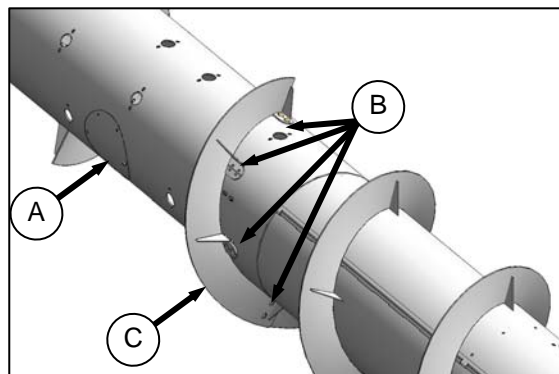

- Remove access cover (A).
- Remove eight bolts (B), washers, and nuts that secure flighting extension (C) to auger, and remove extension.
- Repeat for other flighting extension.
- Re-install access cover (A).

UNLOADING AND ASSEMBLY

C. STRIPPER BARS

Stripper bar kits may have been supplied with your header to improve feeding in certain crops such as rice. They are not recommended in cereal crops.

APPLICABLE COMBINES: All except New Holland CR960, 9060, 970, 9070, and 9080.

If necessary, remove auger stripper bars as follows:

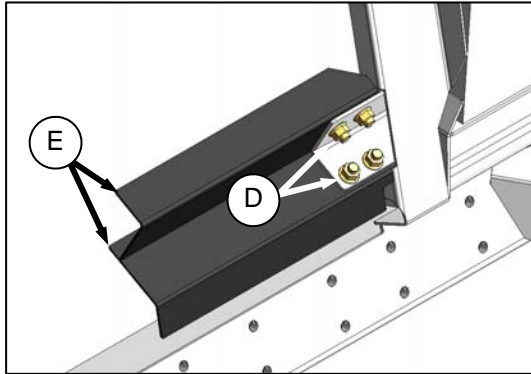

- Remove four bolts (D) and nuts securing bars (E) to adapter frame, and remove bars.
- Repeat for opposite set of stripper bars.

D. CR FEEDER DEFLECTORS

For New Holland CR 960, 9070, and 9080 combines, feeder kits have been installed on the adapter at the factory to improve feeding into the feeder house.

They may also have been installed as an option on older machines. If necessary, they can be removed.

CA20 adapters for the CR Models listed have short feeder kits installed at the factory.

Long feeder kits are provided for narrow feeder house combines, and are dealer-installed to replace the short feeder kits.

COMBINE MODEL	FEEDER HOUSE SIZE	FEEDER KIT SIZE
CR970, 9070, 9080	Wide	Short - 200 mm
CR960, 9060, 940, 9040	Narrow	Long - 325 mm

If required, replace feeder deflectors as follows:

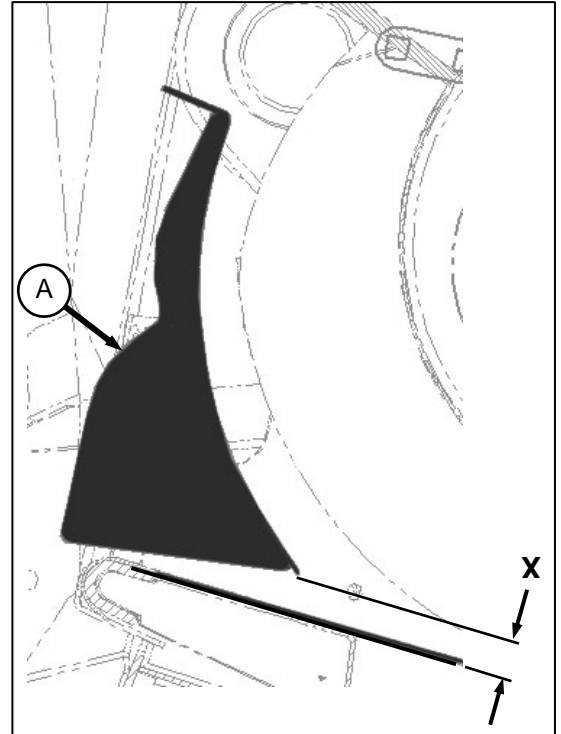

- Determine position of existing deflector (A) by measuring gap 'X' between deflector forward edge and pan.

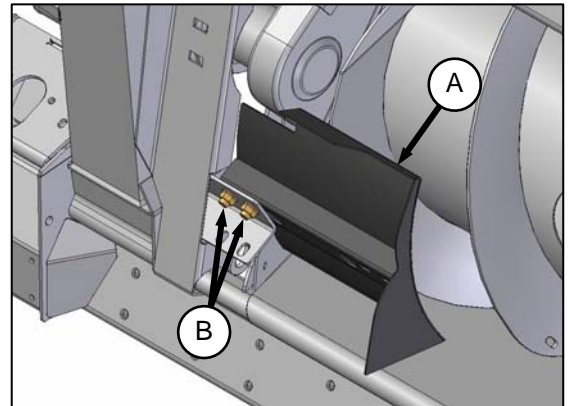

LH SHOWN - RH OPPOSITE

- Remove two bolts (B) and nuts securing deflector (A) to adapter frame, and remove deflector.
- Position replacement deflector, and secure with bolts (B) and nuts. Maintain dimension 'X' from existing deflector for replacement deflector.
- Repeat for opposite deflector.
- After attaching header to combine, extend center-link fully, and check gap between deflector and pan. Maintain 7/8 in. (22 mm) +/- 1/8 in. (3 mm).

UNLOADING AND ASSEMBLY

STEP 9. ATTACH TO COMBINE

Refer to specific section for your combine.

COMBINE	SECTION
CASE IH	A
CASE IH 23, 25 SERIES	B
JOHN DEERE 60 SERIES	C
JOHN DEERE 50 SERIES	D
LEXION	E
NEW HOLLAND	F
AGCO	G

IMPORTANT

Ensure applicable functions (AHHC, Draper Header Option, Hydraulic Center-link Option, Hydraulic Reel Drive, etc.) are enabled on the combine, and combine computer. Failure to do so may result in improper header operation.

IMPORTANT

Some combine models require shorter center-link components to ensure clearance to the combine cab.

To avoid damage to your combine, lift feeder slowly and check clearance between cab and header center-link.

If clearance is inadequate, order short center-link components. Installation instructions are included. See **STEP 8. SET UP ADAPTER.**

A. CASE IH

Case IH 7010, 8010, 7120, 8120, 5088, 6088, 7088.

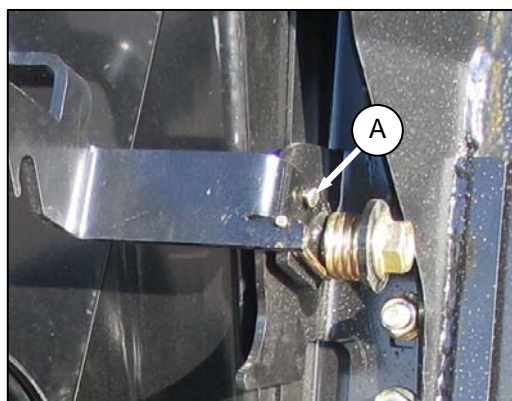

- Remove shipping pin (A). Retain pin for future installation.

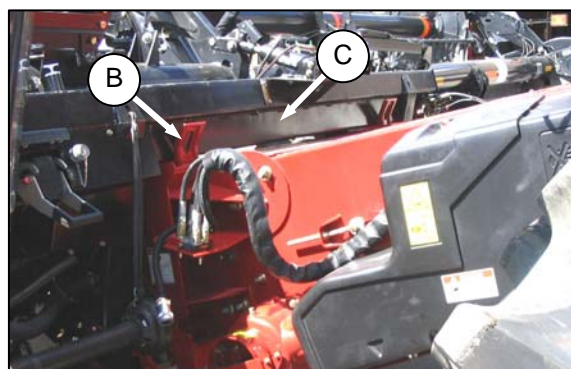

- Slowly drive combine up to header until feeder house saddle (B) is directly under the adapter top cross member (C).
- Raise feeder house to lift header slightly, ensuring feeder saddle is properly engaged in adapter frame.

(continued next page)

UNLOADING AND ASSEMBLY



CAUTION

Stop engine, and remove key from ignition before leaving Operator's seat for any reason. A child or even a pet could engage an idling machine.

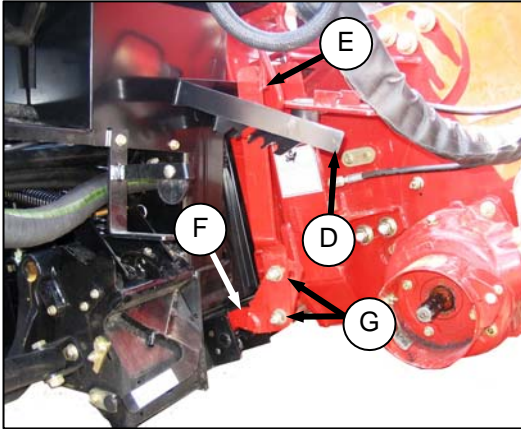

- d. Lift latch (D) on adapter at left side of feeder house, and push handle (E) on combine to engage locks (F) on both sides of the feeder house.
- e. Push down on latch (D) so that slot in latch engages handle (G), locking it in place.
- f. If lock (F) does not fully engage pin on adapter when latch (D) and handle (E) are engaged, loosen bolts (G), and adjust lock as required. Re-tighten bolts.
- g. Remove blocks from under cutterbar.
- h. Start engine, and lower header. Shut down combine.
- i. Connect combine hydraulic quick coupler to receptacle on adapter as follows:

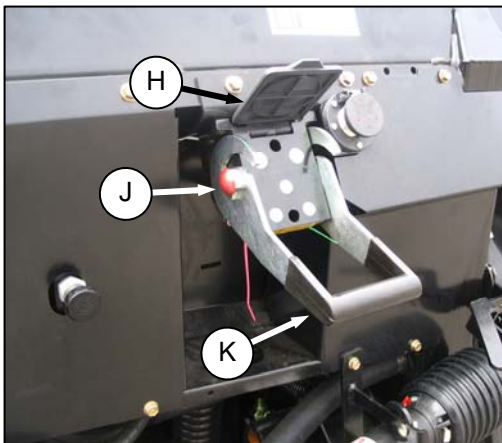

1. Open cover (H).
2. Push in lock button (J), and pull handle (K), to position approximately as shown.

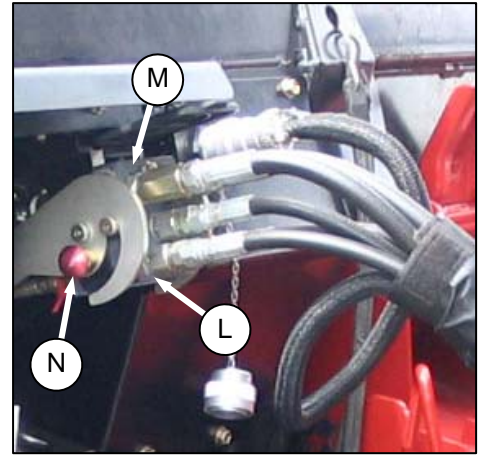

3. Remove coupler (L) from combine, and clean coupler.
4. Position coupler (L) onto adapter receptacle (M), and push handle to engage coupler pins into receptacle.
5. Push handle to "closed position" until lock button (N) snaps out.

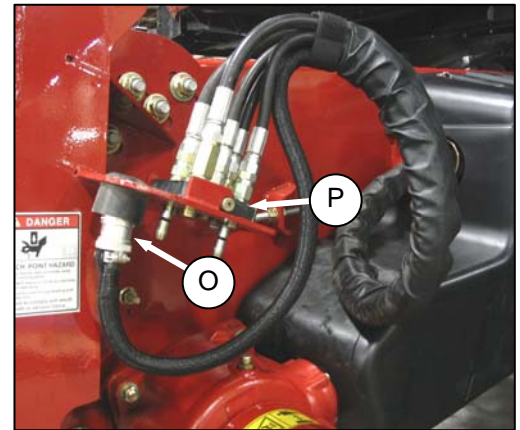

- j. Remove electrical connector (O) from storage cup on combine.

(continued next page)

UNLOADING AND ASSEMBLY

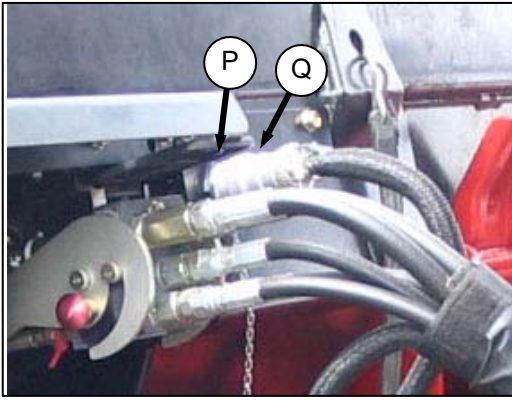

- k. Open cover on adapter electrical receptacle (P); align lugs on connector (Q) with slots in adapter receptacle; push connector onto receptacle; and turn collar on connector to lock it in place.

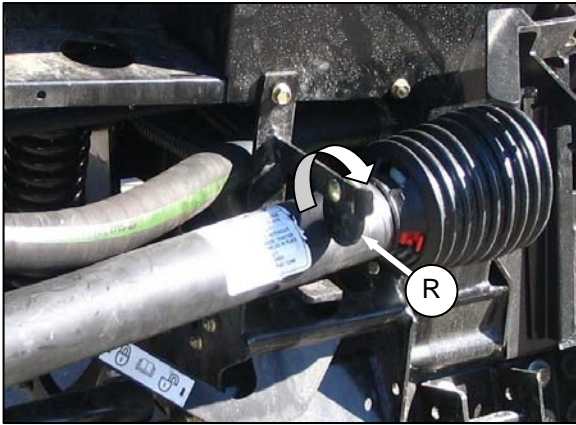

- l. Rotate disc (R) on adapter driveline storage hook and remove driveline from hook.

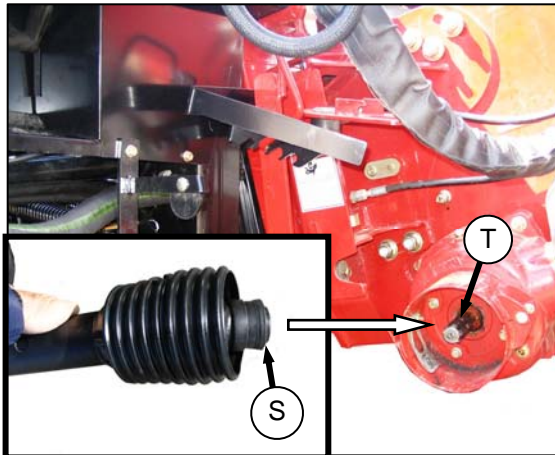

- m. Pull back collar (S) on end of driveline, and push onto combine output shaft (T) until collar locks.
- n. Proceed to page 51, **STEP 10. CONNECT REEL TO FORE-AFT CYLINDERS.**

UNLOADING AND ASSEMBLY

B. CASE IH 23, 25 SERIES

2300, 2500 Series

- a. Attach adapter to combine as follows:

Sliding Pin System

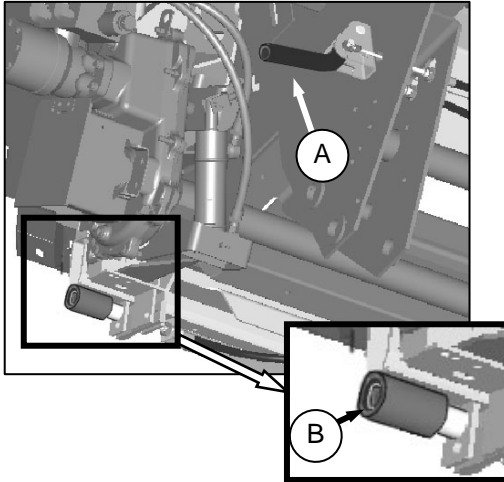

1. Move handle (A) on left side of feeder house to "up" position to retract both pins (B) at lower corners of feeder house.

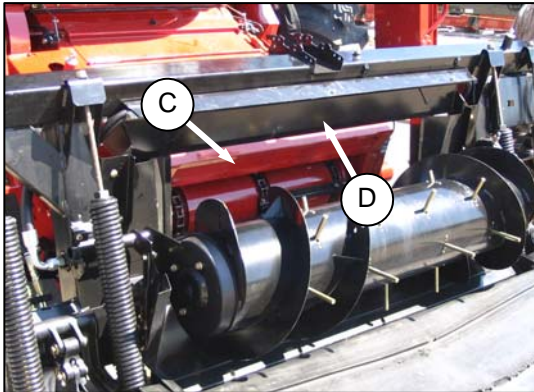

2. Slowly drive combine up to adapter until feeder house saddle (C) is directly under the adapter top cross member (D).

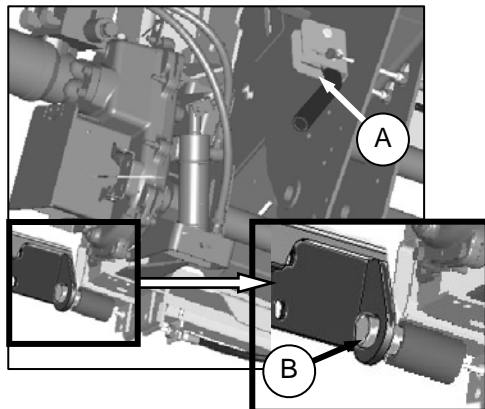

3. Raise feeder house slightly to lift adapter, ensuring feeder saddle is properly engaged in adapter frame.
4. Lower handle (A) to engage pins (B) into adapter.
5. Proceed to step b. (on next page).

Latch System



WARNING

To avoid bodily injury or death from unexpected start-up or fall of raised attachment; stop engine, remove key and engage lift cylinder stop before proceeding with hook-up.

1. Slowly drive combine up to adapter until feeder house saddle (C) is directly under the adapter top cross member (D). See illustration opposite.
2. Raise feeder house fully, and engage combine lift cylinder locks.

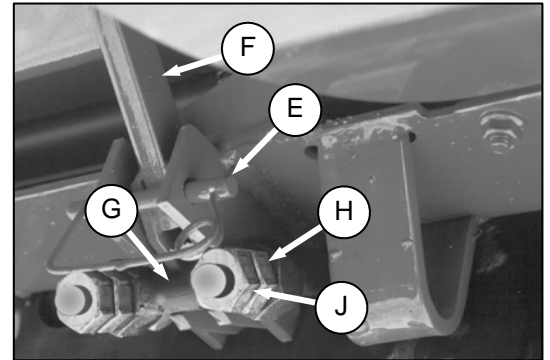

3. Remove pin (E), and lower latch handle (F) (one on each side of feeder house underside) to hook latch (G).
4. Lift handle to "over-center" position to lock. Requires 40 - 50 lbf (180 - 220 N) to move handle "over-center". Adjust nuts (H) on U-bolts to vary force required on handle.
5. Tighten jam-nuts (J) when force is correct.
6. Install pin (E) as shown on previous page, to secure latch handle in locked position.
7. Remove combine lift cylinder locks, and lower header to ground.

(continued next page)

UNLOADING AND ASSEMBLY

b. Connect combine hydraulics to adapter as follows:

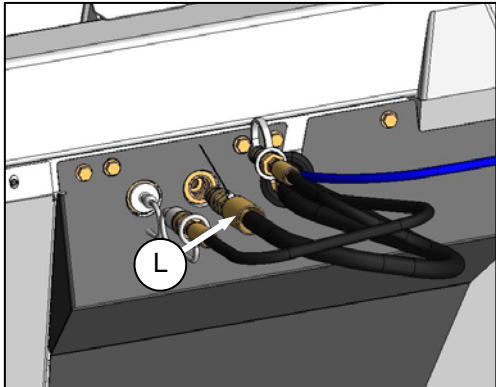
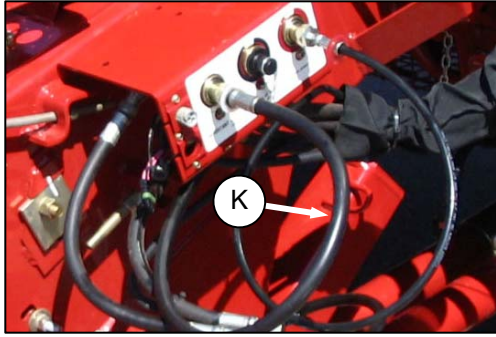

1. Disconnect reel drive hoses (K) and (L) (white discs) from combine and adapter receptacles.

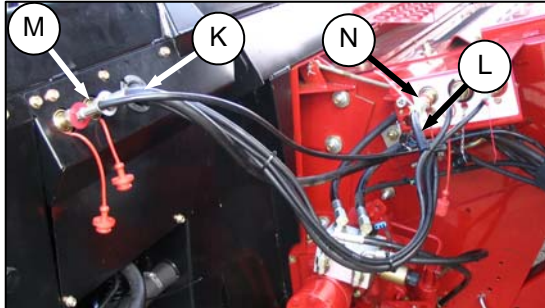

2. Connect hose (K) from combine to adapter coupler (M).
3. Connect hose (L) from the adapter to the combine coupler (N).

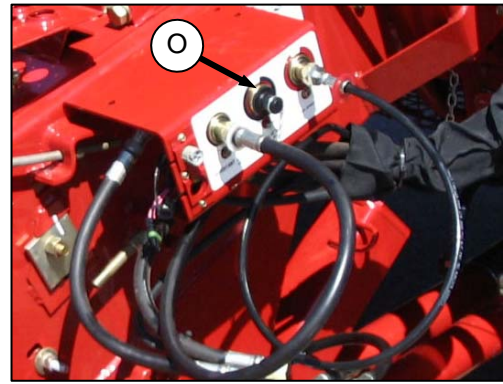

4. Remove plug from reel lift coupler (O) (black disc) on combine.

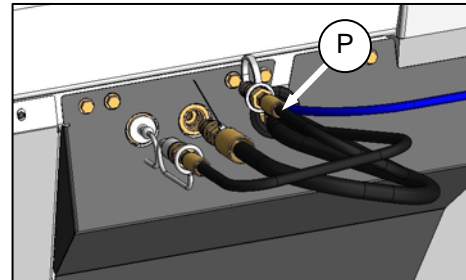

5. Remove red dust cap from reel lift hose (P) on adapter, and connect hose to combine coupler (O).

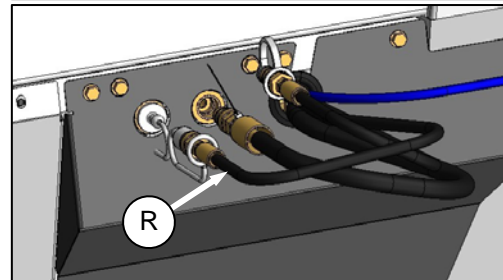

6. Disconnect reel fore-aft hoses (Q) and (R) (red discs) from combine and adapter receptacles.

(continued next page)

UNLOADING AND ASSEMBLY

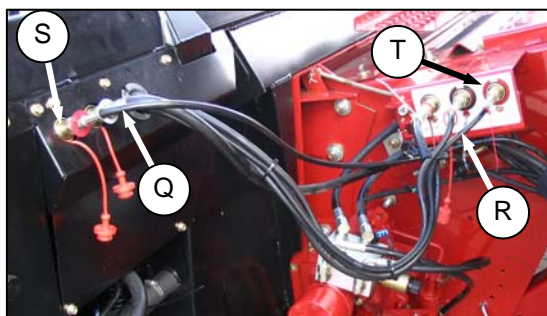

7. Connect hose (Q) from combine to adapter coupler (S).
8. Connect hose (R) from the adapter to the combine coupler (T).

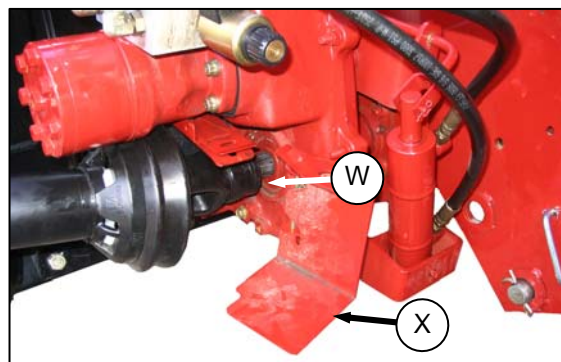

- f. Pull back collar on end of driveline, and push onto combine output shaft (W) until collar locks. Close guard (X).

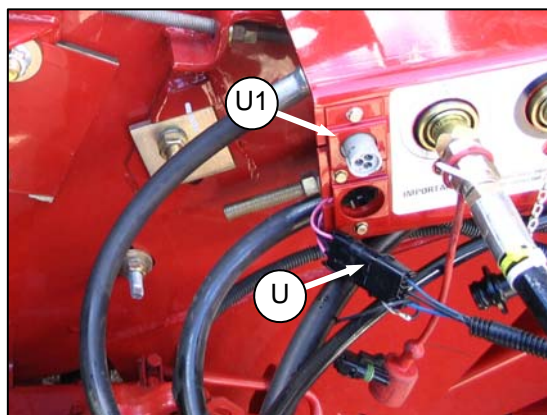

- c. Connect adapter electrical harness (U) to combine electrical connector, and if applicable connect AHHC wire harness at U1.
- d. Open guard at combine output shaft.

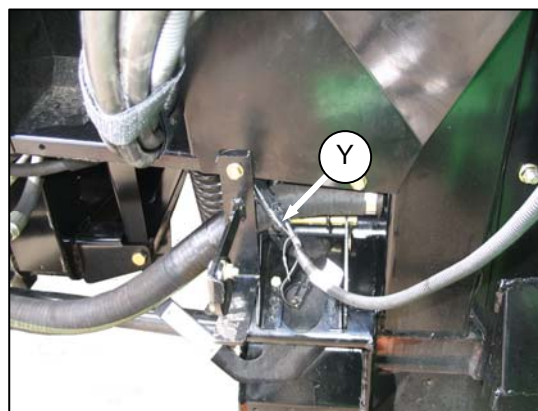

- g. If adapter is equipped with reel fore-aft/header tilt selector, connect harness (Y) to combine.
- h. Proceed to page 51, **STEP 10. CONNECT REEL TO FORE-AFT CYLINDERS.**



- e. Rotate disc (V) on adapter driveline storage hook, and remove driveline from hook.

UNLOADING AND ASSEMBLY

C. JOHN DEERE 60 SERIES

Contour Master, Level Land

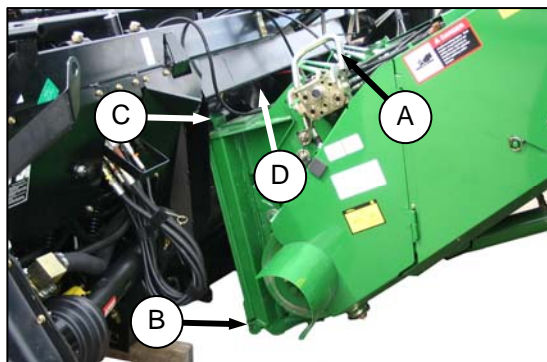

- Push handle (A) on combine coupler toward feeder house to retract pins (B) at bottom corners of feeder house.
- Slowly drive combine up to adapter until feeder house saddle (C) is directly under the adapter top cross member (D).
- Raise feeder house to lift adapter, ensuring feeder saddle is properly engaged in adapter frame.
- Raise or lower header until slightly off the ground.



CAUTION

Stop engine, and remove key from ignition before leaving Operator's seat for any reason. A child or even a pet could engage an idling machine.

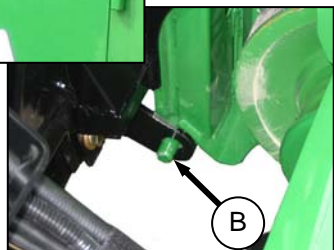
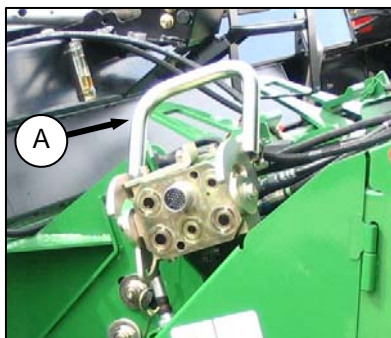

- Pull handle (A) to near vertical position, to engage pins (B) in adapter.

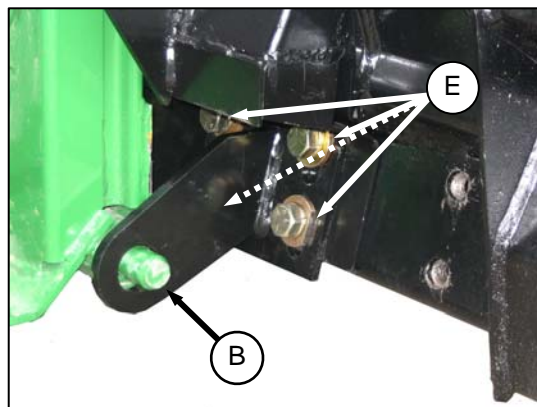

- Check that bolts (E) on adapter brackets are tight.
- If pins (B) do not fully engage adapter brackets, loosen bolts (E), and adjust bracket as required. Re-tighten bolts.
- Remove blocks from under cutterbar.
- Start engine, and lower header.

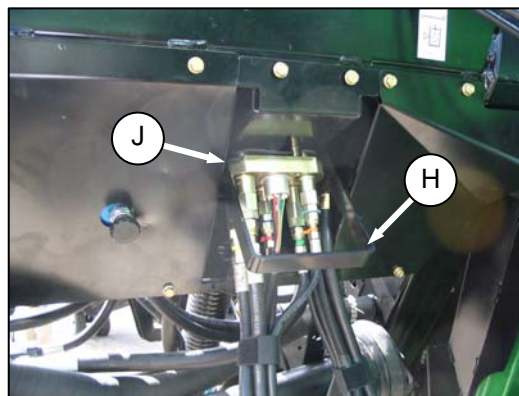

- Pull handle (H) on adapter to release coupler (J) from storage position. Remove coupler, and push handle back into adapter to store.

(continued next page)

UNLOADING AND ASSEMBLY

k. Attach coupler (J) to combine as follows:

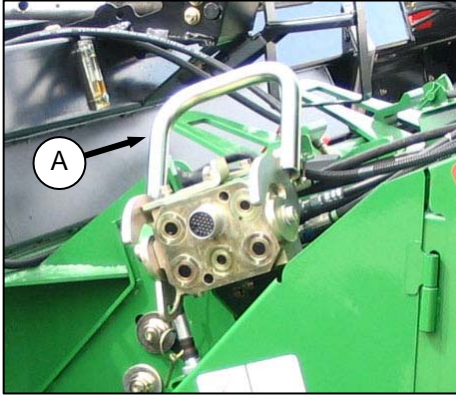

1. Handle (A) should be in the “nearly up” position. Clean receptacle.

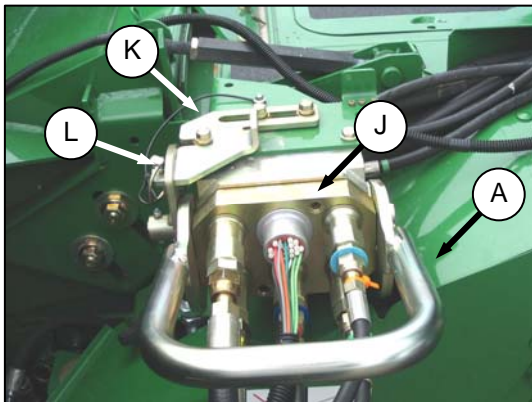

2. Locate coupler (J) onto receptacle, and pull handle (A) so that lugs on coupler are engaged into handle.
3. Pull handle to full horizontal position as shown.
4. Slide latch (K) to lock handle in position, and secure with lynch pin (L).

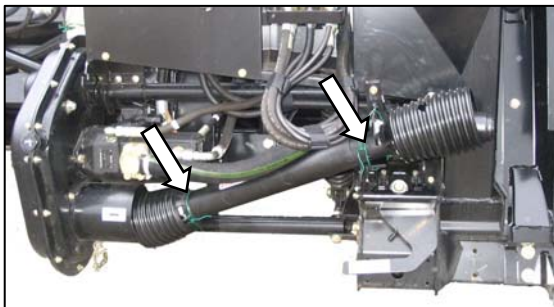

l. Remove shipping wire from driveline.

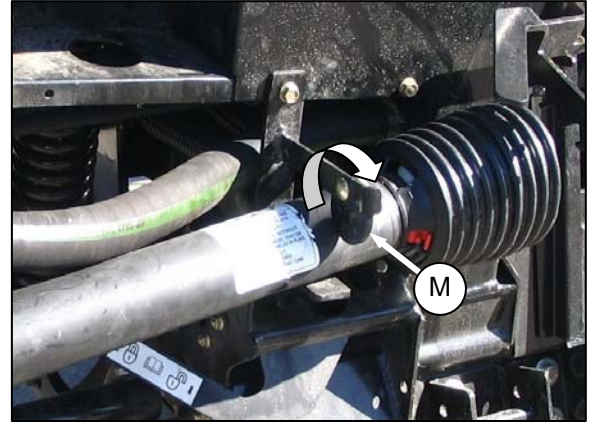

- m. Rotate disc (M) on adapter drive-line storage hook, and remove drive-line from hook.

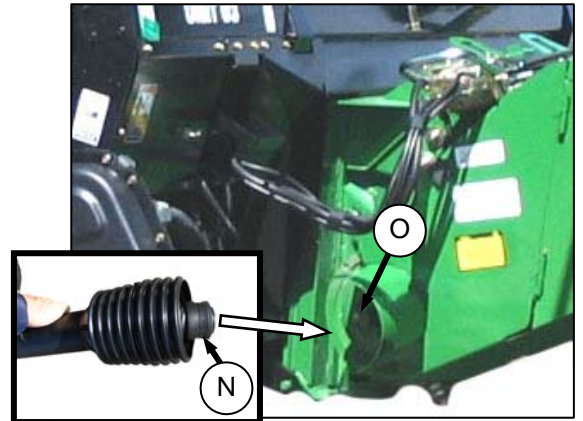

- n. Pull back collar (N) on end of driveline, and push onto combine output shaft (O) until collar locks.

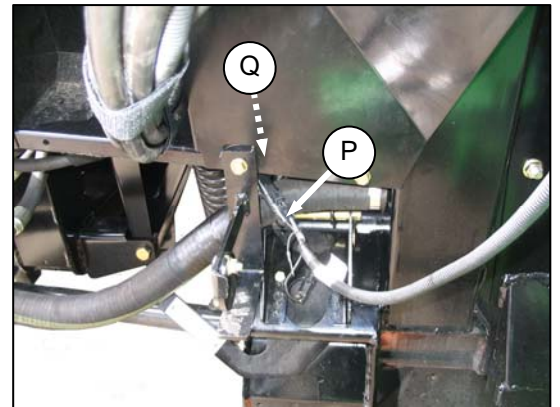

- o. If adapter is equipped with reel fore-aft/header tilt selector, connect harness (P) to combine.

NOTE

Connector (P) may need to be retrieved from hydraulics compartment access hole (Q).

- p. Proceed to **STEP 10. CONNECT REEL TO FORE-AFT CYLINDERS (page 51).**

UNLOADING AND ASSEMBLY

D. JOHN DEERE 50 SERIES

Contour Master, Level Land

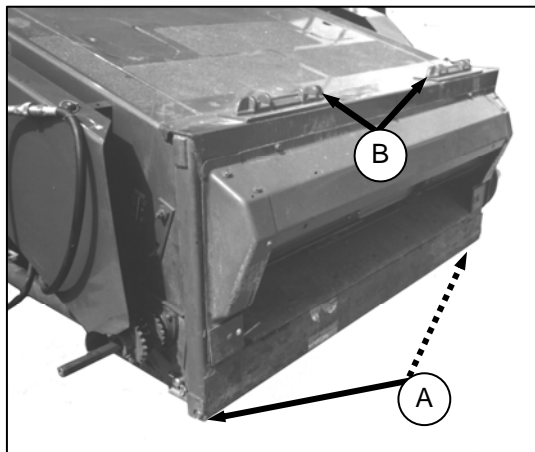

- a. Retract pins (A) at bottom corners of feeder house.

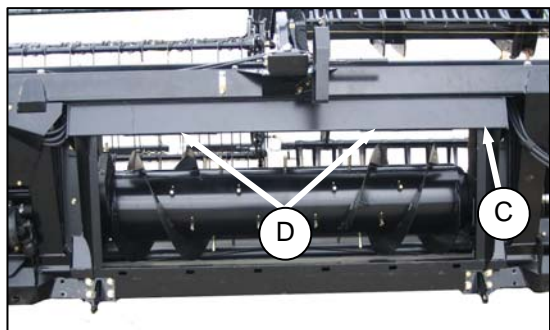

- b. Slowly drive combine up to adapter until feeder house lift lugs (B) are directly under the adapter top cross member (C).
- c. Raise feeder house to lift adapter, ensuring lift lugs (B) are properly engaged in adapter frame sockets (D).
- d. Raise or lower header until slightly off the ground.



CAUTION

Stop engine, and remove key from ignition before leaving Operator's seat for any reason. A child or even a pet could engage an idling machine.

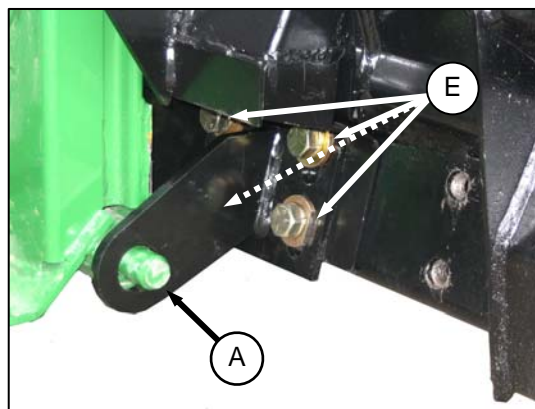

- e. Engage pins (A) in adapter.
- f. Check that bolts (E) on adapter brackets are tight.
- g. If pins (A) do not fully engage adapter brackets, loosen bolts (E), and adjust bracket as required. Re-tighten bolts.
- h. If required, remove blocks from under cutterbar.
- i. Start engine, and lower header.

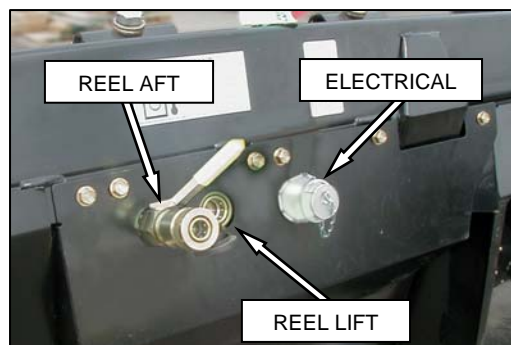

- j. At left side of combine feeder house, retrieve reel aft hose, reel lift hose and electrical harness.
- k. Clean couplers, and attach as shown above.
- l. At right side of feeder house, disconnect reel drive hoses, and retrieve reel fore hose.

(continued next page)

UNLOADING AND ASSEMBLY

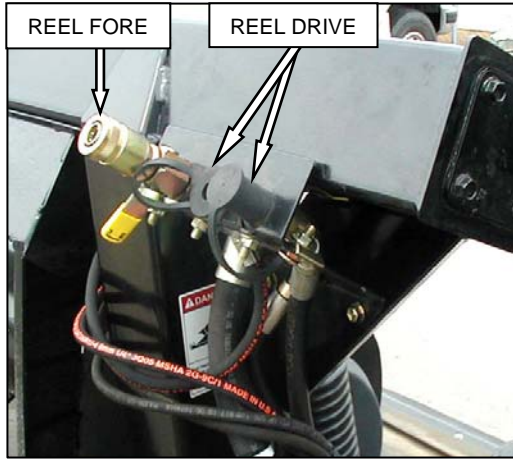

m. Clean couplers, and attach as shown above.

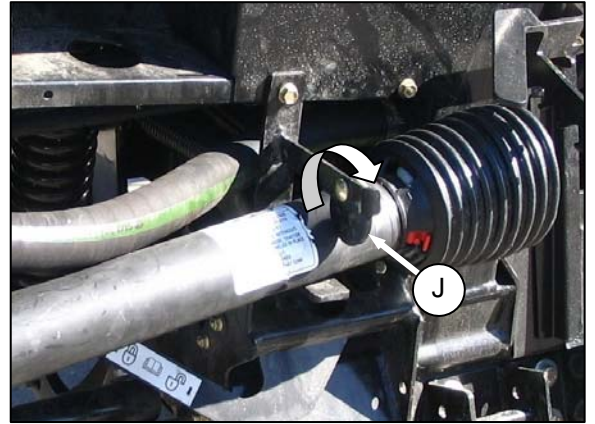

p. Rotate disc (J) on adapter drive-line storage hook, and remove drive-line from hook.

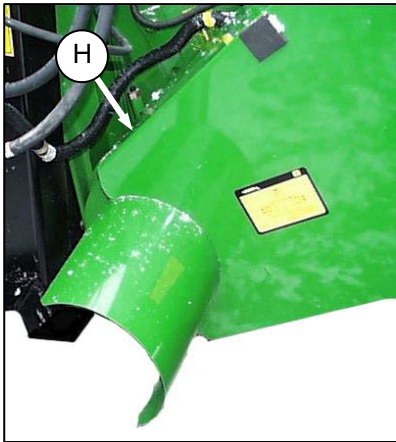

n. Open shield (H) on combine.

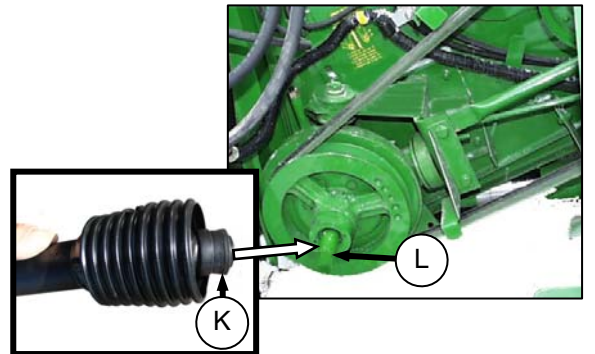

q. Pull back collar (K) on end of driveline, and push onto combine output shaft (L) until collar locks.

r. Close drive shield (H) on combine.

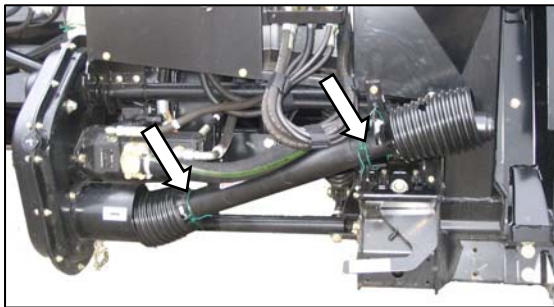

o. Remove shipping wire securing driveline to adapter.

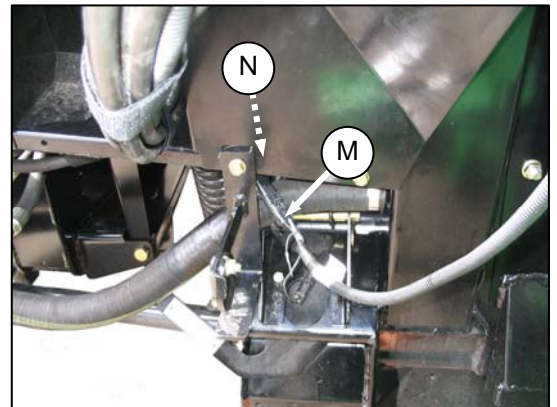

s. If adapter is equipped with reel fore-aft/header tilt selector, connect harness (M) to combine.

NOTE

Connector (M) may need to be retrieved from hydraulics compartment access hole (N).

t. Proceed to **STEP 10. CONNECT REEL TO FORE-AFT CYLINDERS (page 51).**

UNLOADING AND ASSEMBLY

E. CAT LEXION 400, 500 SERIES

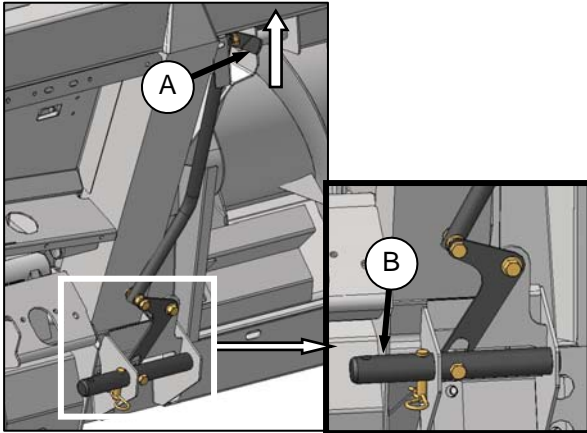

- Handle (A) on the CA20 adapter should be in raised position, and pins (B) at bottom corners of adapter should be retracted.
- Slowly drive combine up to header until feeder house is directly under the adapter top cross member.

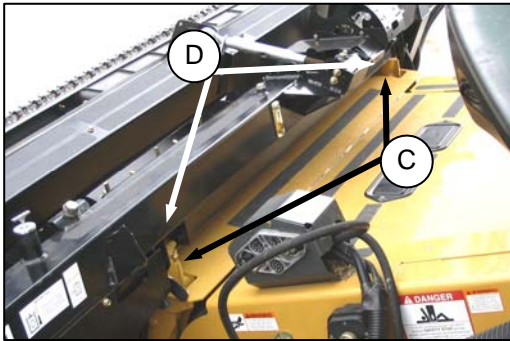

- Raise feeder house to lift adapter, ensuring feeder house posts (C) are properly engaged in adapter frame (D).
- Position header slightly off the ground.



CAUTION

Stop engine, and remove key from ignition before leaving Operator's seat for any reason. A child or even a pet could engage an idling machine.

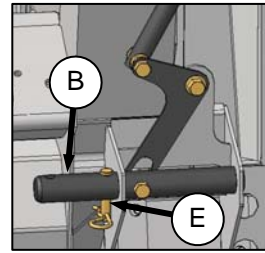

- Remove locking pin (E) from adapter pin (B).

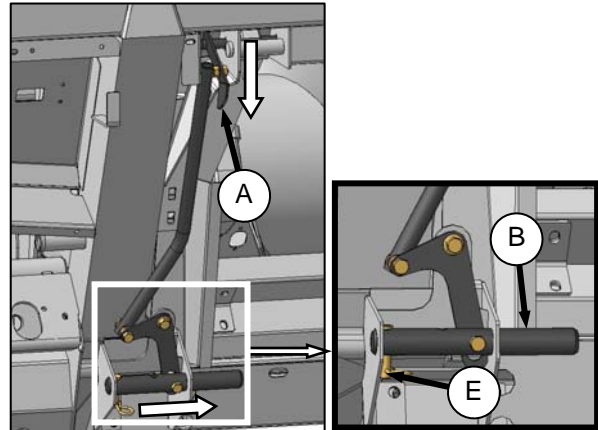

- Lower handle (A) to engage adapter pins into feeder house. Re-insert locking pin (E), and secure with hairpin.
- Remove blocks from under cutterbar.
- Start engine, and lower header. Shutdown the combine.

(continued next page)

UNLOADING AND ASSEMBLY

i. Connect hydraulic hoses as follows:

400 Series

500 Series

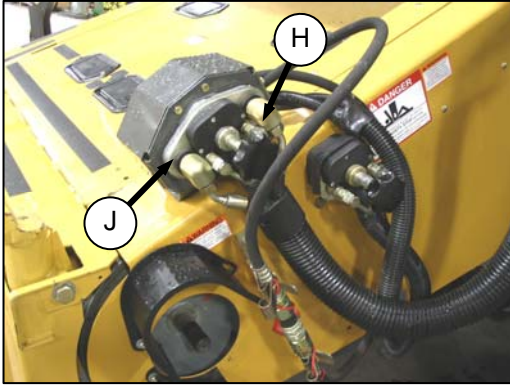

1. Unscrew knob (H) on combine coupler (J) to release coupler from combine receptacle.

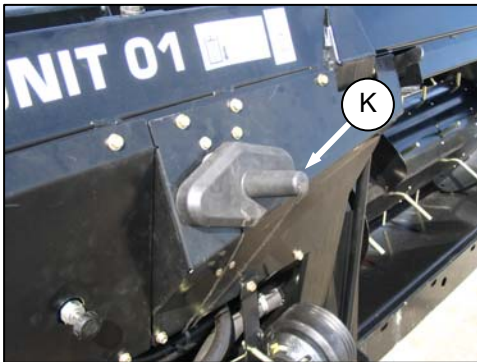

2. Remove cover (K) from adapter receptacle.

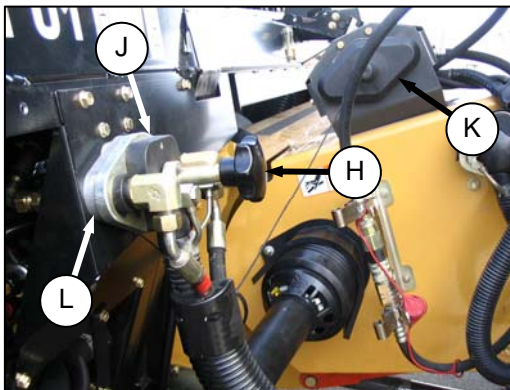

3. Locate coupler (J) onto adapter receptacle (L), and turn knob (H) to secure coupler to receptacle.
4. Place cover (K) on combine receptacle.
5. Proceed to step k.

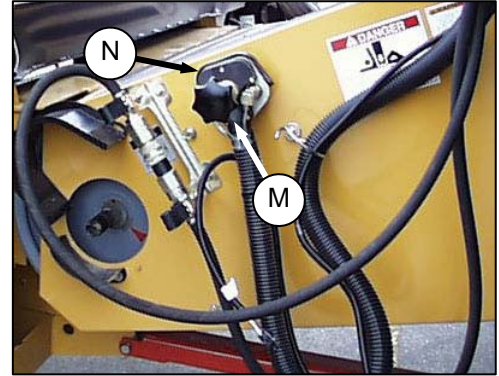

1. Unscrew knob (M) on combine coupler (N) to release coupler from combine receptacle.

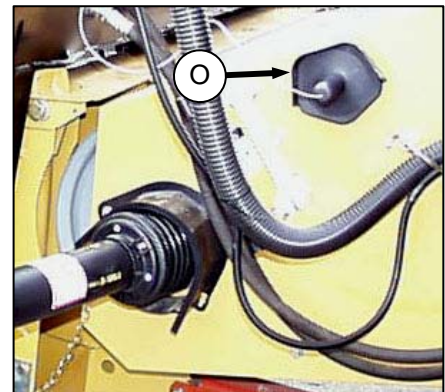
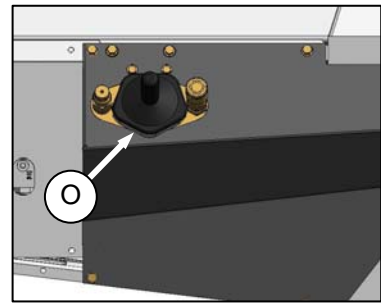

2. Remove cover (O) from adapter receptacle, and place on combine receptacle.

(continued next page)

UNLOADING AND ASSEMBLY

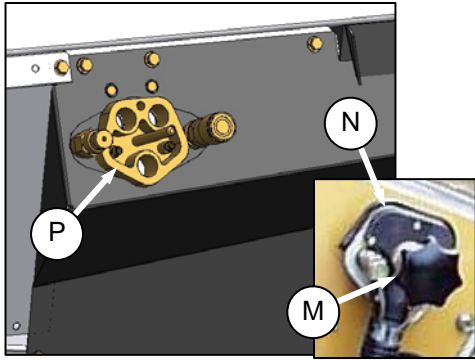

3. Locate coupler (N) onto adapter receptacle (P), and turn knob (M) to secure coupler to receptacle.

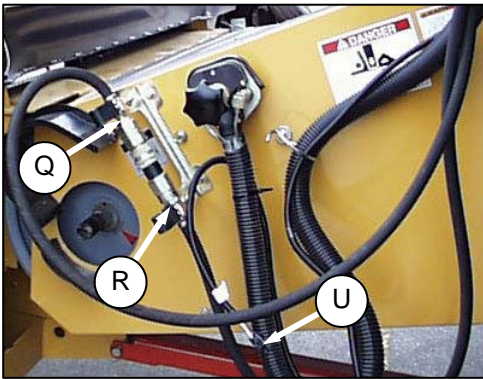

4. Disconnect hoses (Q) and (R) on combine at couplers.

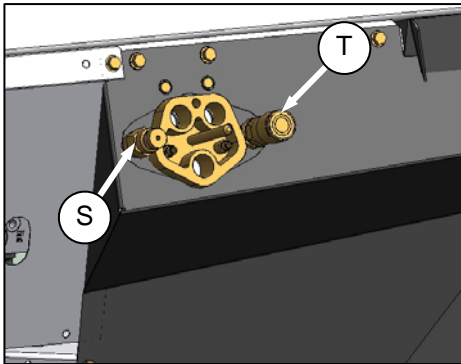

5. Connect hose (Q) to coupler (S) on adapter.
6. Connect hose (R) to coupler (T) on adapter.
7. Connect wiring harness (U) to adapter connector (not shown).

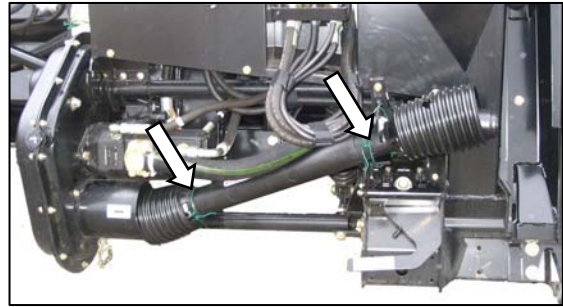

- j. Remove shipping wire securing driveline to adapter.

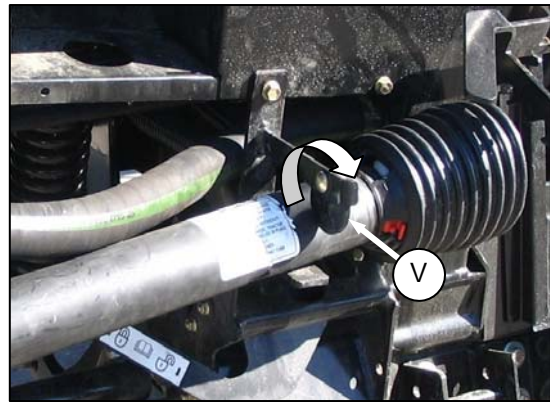

- k. Rotate disc (V) on adapter drive-line storage hook, and remove drive-line from hook.

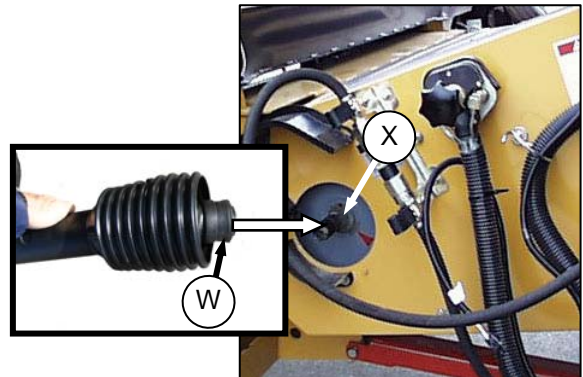

- l. Pull back collar (W) on end of driveline, and push onto combine output shaft (X) until collar locks.

(continued next page)

UNLOADING AND ASSEMBLY

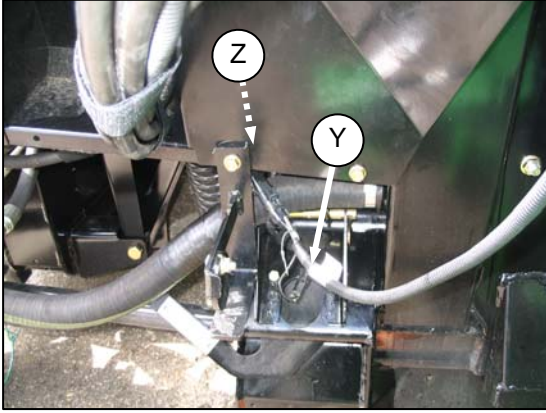

- m. If adapter is equipped with reel fore-aft/header tilt selector, connect harness (Y) to combine.

NOTE

Connector (Y) may need to be retrieved from hydraulics compartment access hole (Z).

- n. Proceed to **STEP 10. CONNECT REEL TO FORE-AFT CYLINDERS** (page 51).

UNLOADING AND ASSEMBLY

F. NEW HOLLAND

CR, CX

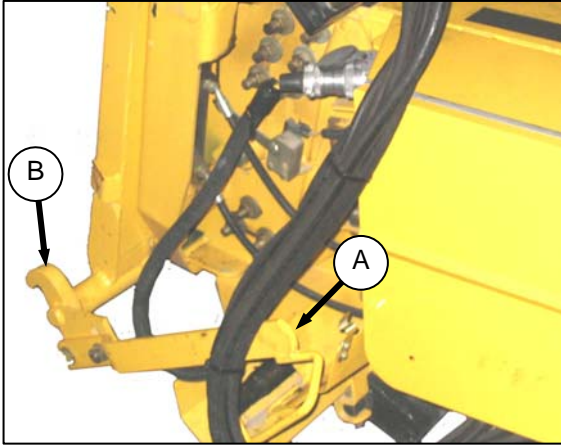

- a. Ensure handle (A) is positioned so that hooks (B) can engage adapter.

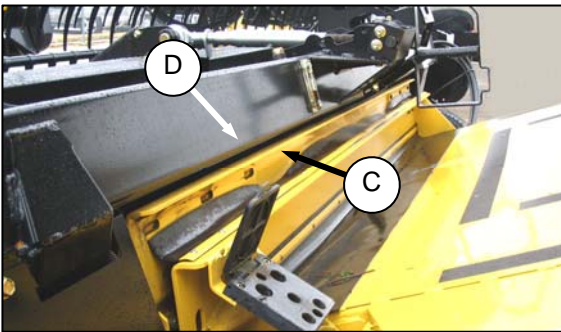

- b. Slowly drive combine up to adapter until feeder house saddle (C) is directly under the adapter top cross member (D).
- c. Raise feeder house to lift adapter, ensuring feeder saddle is properly engaged in adapter frame.



CAUTION

Stop engine, and remove key from ignition before leaving Operator's seat for any reason. A child or even a pet could engage an idling machine.

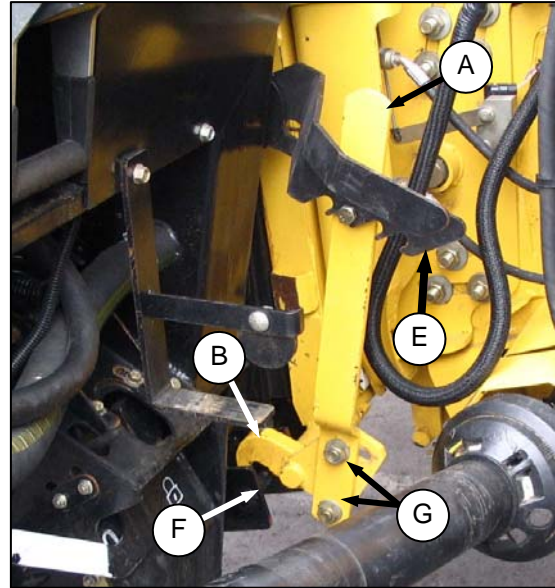

- d. Lift lever (E) on adapter at left side of feeder house, and push handle (A) on combine so that hooks (B) engage pins (F) on both sides of the feeder house.
- e. Push down on lever (E) so that slot in lever engages handle to lock handle in place.
- f. If hook (B) does not fully engage pin on adapter when (A) and (E) are engaged, loosen bolts (G), and adjust lock as required. Re-tighten bolts.
- g. Connect combine hydraulics to receptacle on adapter as follows:

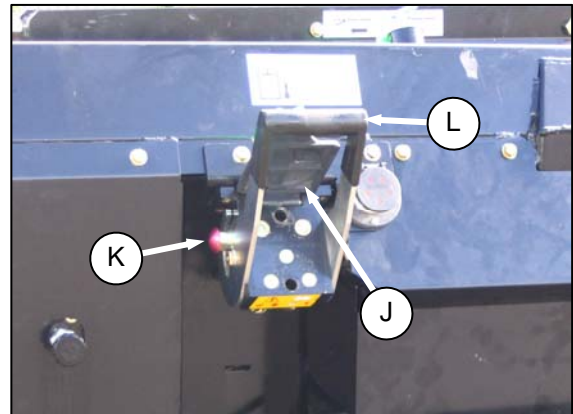

1. Open cover (J).
2. Push in lock button (K), and pull handle (L) "halfway up" to "open" position.

(continued next page)

UNLOADING AND ASSEMBLY

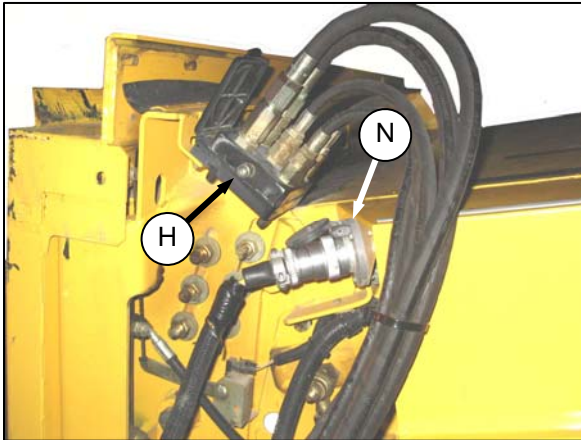

3. Remove coupler (H) from storage location on combine, and clean mating surface of coupler.

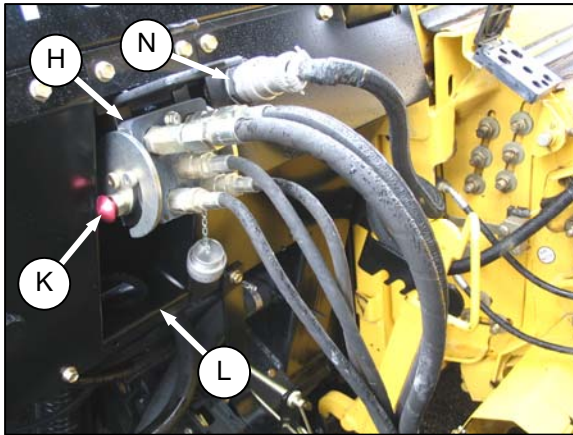

4. Position coupler (H) onto adapter receptacle, and push handle (L) to engage pins into receptacle.
 5. Push handle (L) to "closed" position until lock button (K) snaps out.
- h. Attach combine electrical connector to adapter as follows:
1. Remove cover on adapter electrical receptacle.
 2. Remove connector (N) from combine.
 3. Align lugs on connector (N) with slots in adapter receptacle, and push connector onto receptacle. Turn collar on connector to lock it in place.

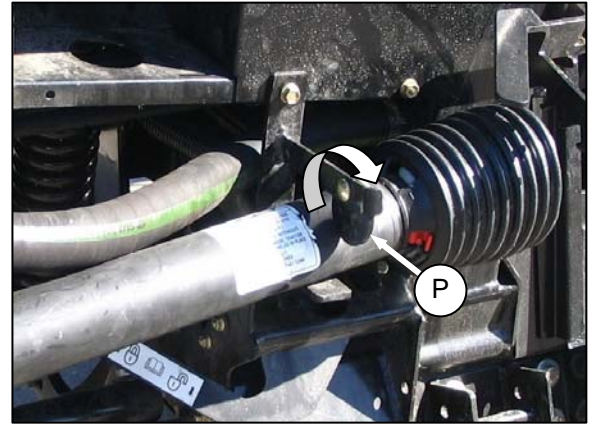

- i. Rotate disc (P) on adapter driveline storage hook, and remove driveline from hook.

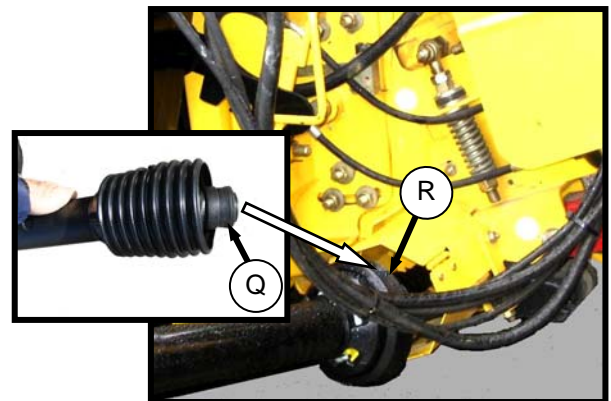

- j. Pull "back" collar (Q) on end of driveline, and push onto combine output shaft (R), until collar locks.
- k. Proceed to page 51, **STEP 10. CONNECT REEL TO FORE-AFT CYLINDERS.**

UNLOADING AND ASSEMBLY

G. AGCO

Gleaner R Series, A Series
Challenger 660, 670, 680B
Massey 9690, 9790, 9895

IMPORTANT

Some combine models require shorter center-link components to ensure clearance to the combine cab.

To avoid damage to your combine, lift feeder slowly and check clearance between cab and header center-link.

If clearance is inadequate, order short center-link components. Installation instructions are included. See **STEP 8. SET UP ADAPTER.**

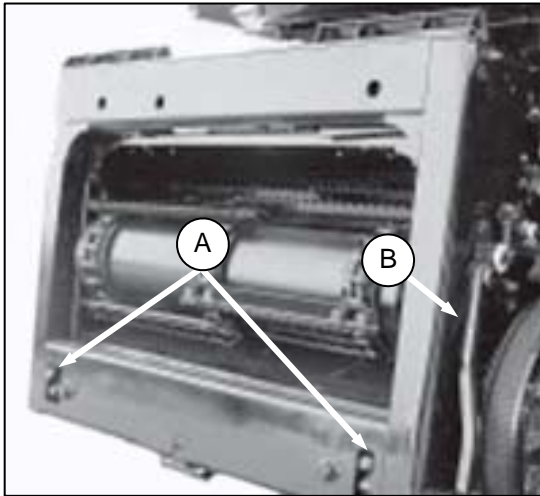

GLEANER 'R' SERIES

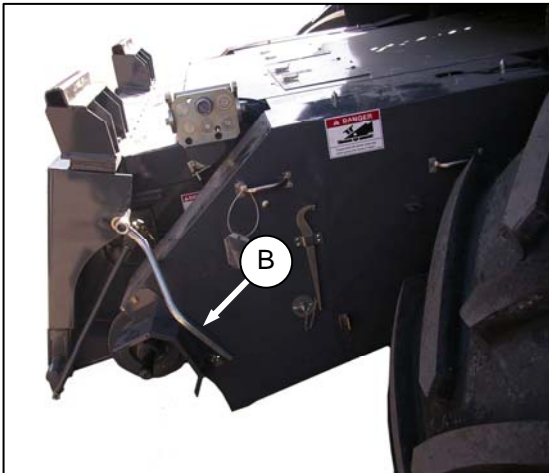

ALL EXCEPT GLEANER 'R' SERIES

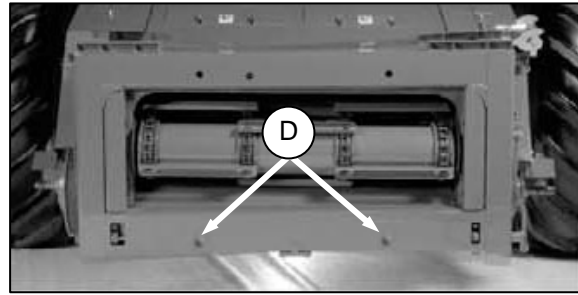

ALL EXCEPT GLEANER 'R' SERIES
and 'LL' MODEL

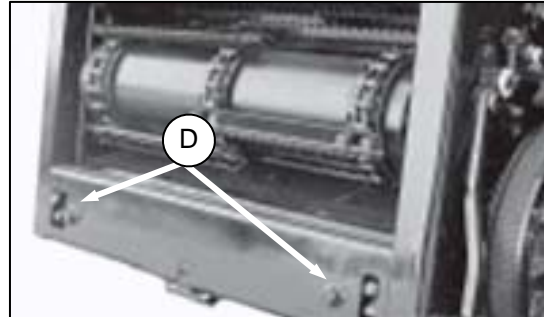

GLEANER 'R' SERIES

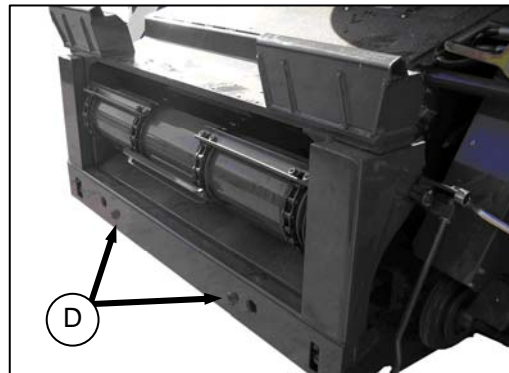

'LL' MODEL

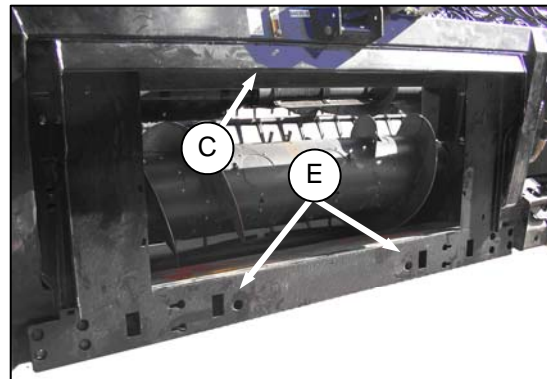

- a. Retract lugs (A) at base of feeder-house with lock handle (B).

- b. Slowly drive combine up to adapter until feeder house is directly under the adapter top cross member (C), and alignment pins (D) are aligned with holes (E) in adapter frame.

(continued next page)

UNLOADING AND ASSEMBLY

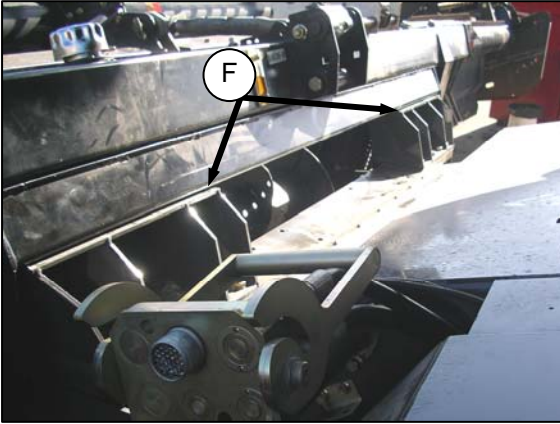

- c. Raise feeder house to lift adapter, ensuring feeder house saddle (F) and alignment pins are properly engaged in adapter frame.
- d. Position header slightly off the ground.



CAUTION

Stop engine, and remove key from ignition before leaving Operator's seat for any reason. A child or even a pet could engage an idling machine.

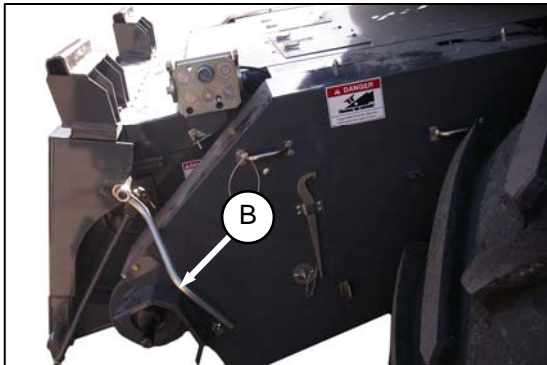

ALL EXCEPT GLEANER 'R' SERIES

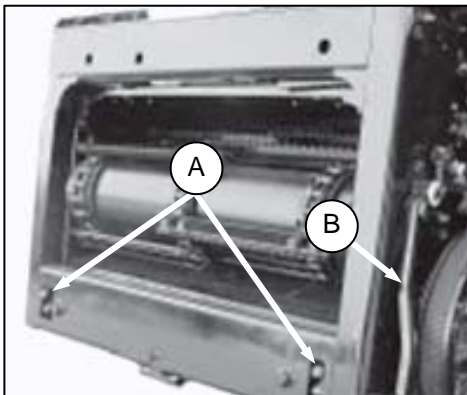

GLEANER 'R' SERIES

- e. Engage lugs (A) with adapter using lock handle (B).

- f. Remove blocks from under cutterbar.
- g. Start engine, and lower header. Shut down combine.

NOTE

The CA20 Combine Adapter is equipped with a multi-coupler that connects to the combine.

If your combine is equipped with individual connectors, a multi-coupler kit (single-point connector) must be installed. The kits are available through your AGCO dealer and include installation instructions.

COMBINE	AGCO KIT #
Challenger	71530662
Massey	71411594
Gleaner 'R' Series	71414706

- h. Connect adapter hydraulic quick coupler to combine receptacle as follows:

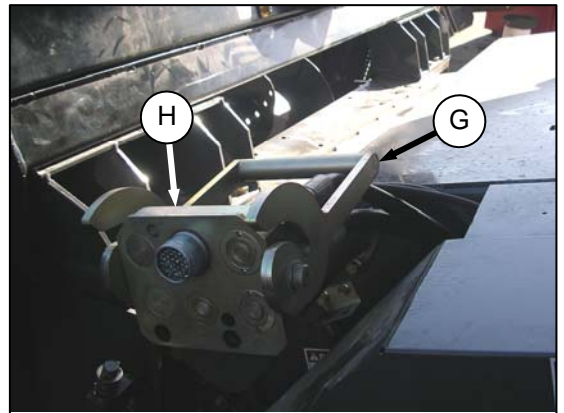

1. Push handle (G) on combine to "full open" position. Clean receptacle (H).

(continued next page)

UNLOADING AND ASSEMBLY

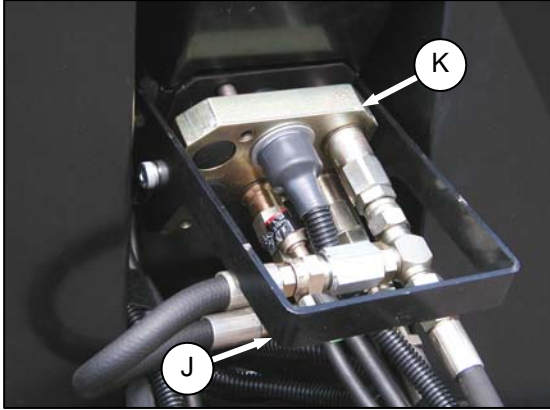

2. Pull handle (J) to release coupler (K) from adapter.

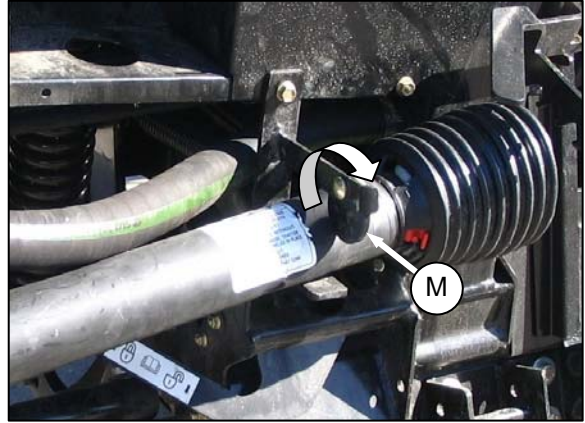

- j. Rotate disc (M) on adapter drive-line storage hook, and remove drive-line from hook.

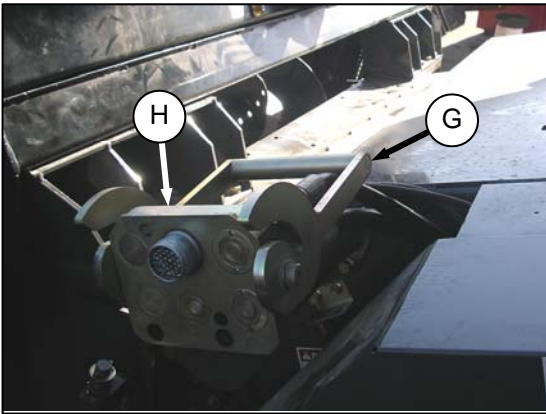

3. Position coupler (K) onto combine receptacle (H), and pull handle (G) to fully engage coupler into receptacle (H).

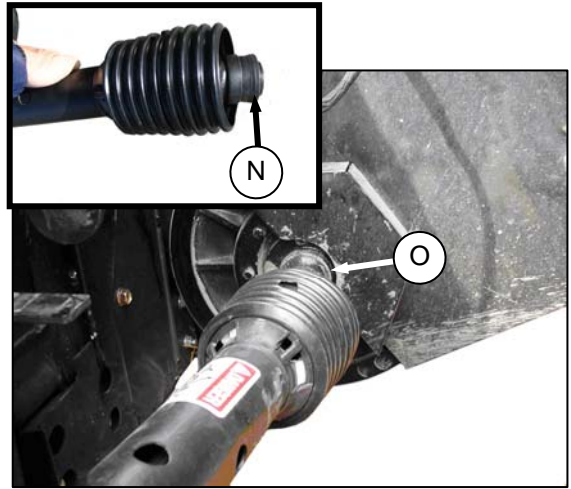

- k. Pull back collar (N) on end of drive-line, and push onto combine output shaft (O) until collar locks.

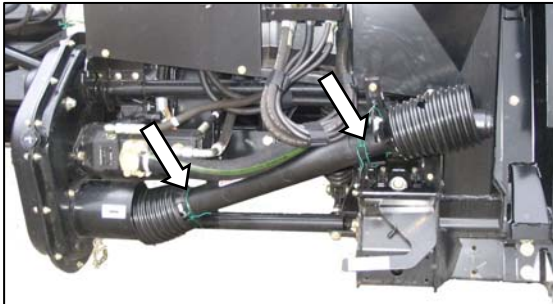

- i. Remove shipping wire securing drive-line to adapter.

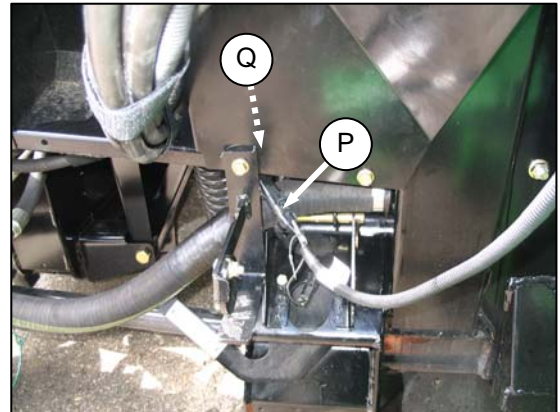

- l. Connect harness (P) to combine.

NOTE

Connector (P) may need to be retrieved from hydraulics compartment access hole (Q).

- m. Proceed to **STEP 10. CONNECT REEL TO FORE-AFT CYLINDERS** (page 51).

UNLOADING AND ASSEMBLY

STEP 10. CONNECT REEL TO FORE-AFT CYLINDERS



CAUTION

The reel fore-aft hydraulic cylinders must be connected to the reel prior to removing the fore-aft supports. Failure to do so may result in the reel sliding full forward when the supports are removed.



CAUTION

Reel arms must be level prior to removing reel shipping braces. Failure to do so may result in reel moving suddenly.



CAUTION

Be sure all bystanders are clear of machine before starting engine or engaging any header drives.

- Remove shipping wire and pins from fore-aft cylinders on each reel support arm. Pin may be installed in arm.
- Start combine engine, and level the reel arms with the combine hydraulics.
- Extend and retract fore-aft cylinders to re-phase cylinders.
- Align cylinders with reel arm mounting holes with combine hydraulics. Stop engine, and remove key.
- Attach fore-aft cylinders to reel arms with clevis pins, washers, and cotter pins.

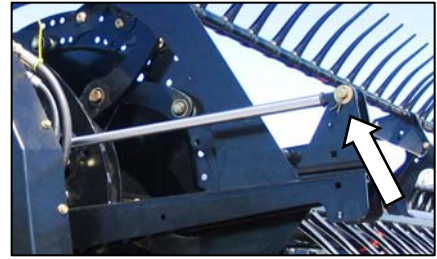

D50 RH ARM

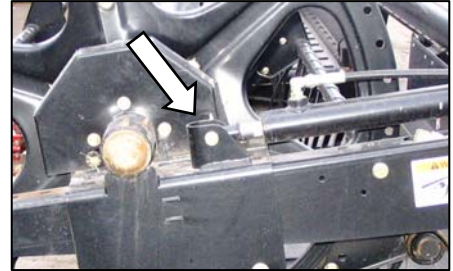

D50 LH ARM

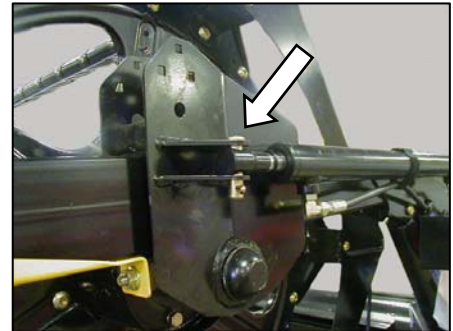

D60 LH ARM

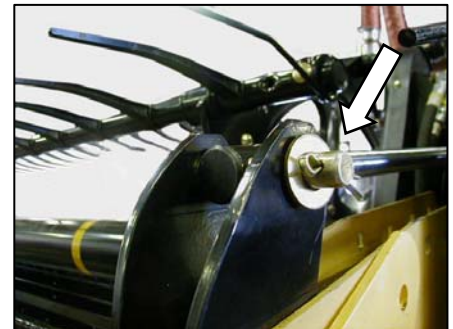

D60 DOUBLE REEL CENTER ARM

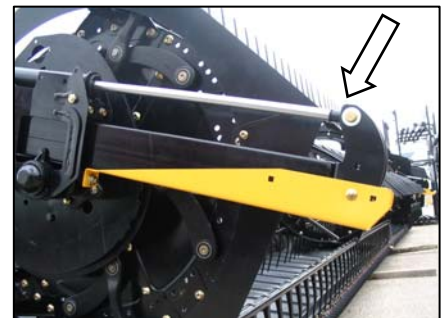

D60 RH ARM

(continued next page)

UNLOADING AND ASSEMBLY

STEP 11. ATTACH CAM ARMS

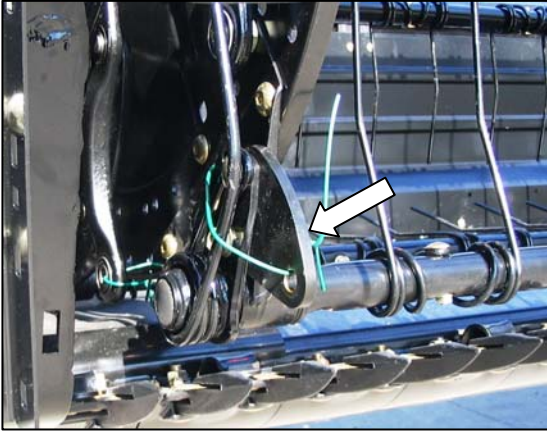

- a. Manually rotate reel until the tine bars with the disconnected cam links are accessible.
- b. Remove shipping wire if not already removed.

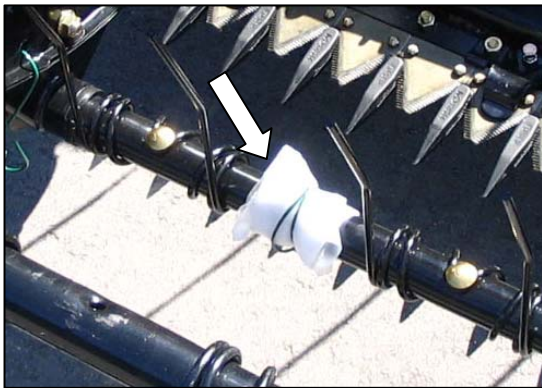

- c. Remove bag of hardware from tine bar. It contains hardware for cam links and endshields.

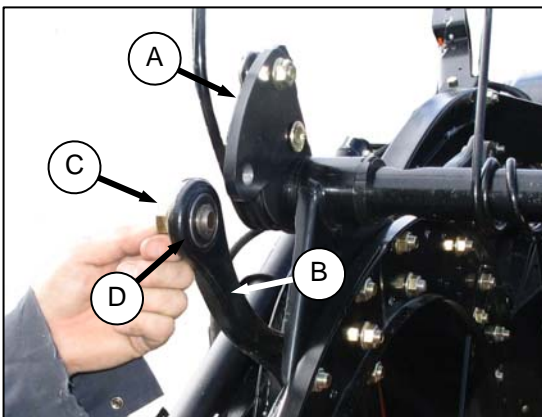

- d. Rotate tine bar crank (A), and position link (B) until attachment holes in bar crank and link are approximately aligned.

- e. Install bolt (C) in link, and position shim (D) (5/8 inch ID lockwasher on D50) on bolt so that shim is between link and tine bar crank.

NOTE

Bolts are pre-coated with Loctite®, so no further locking method is required.

- f. Re-align link and tine bar crank, and thread in the bolt (C).
- g. Repeat for remaining tine bars, and torque bolts to 120 ft-lbf (165 N·m).

UNLOADING AND ASSEMBLY

STEP 12. INSTALL REEL ENDSHIELDS

Up to three endshields on each end of some reels were removed for shipping purposes.

If necessary, re-install shields as follows.

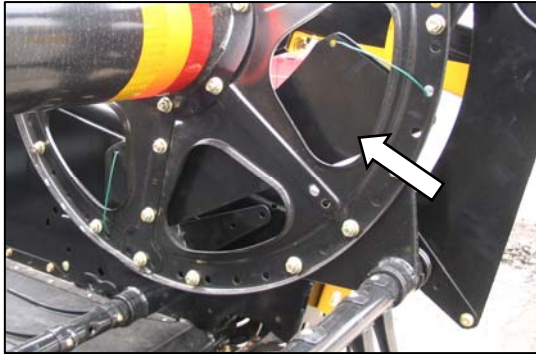

- Manually rotate reel until the wired endshields are accessible. Remove endshields.
- Manually rotate reel for accessibility to re-install the shields.

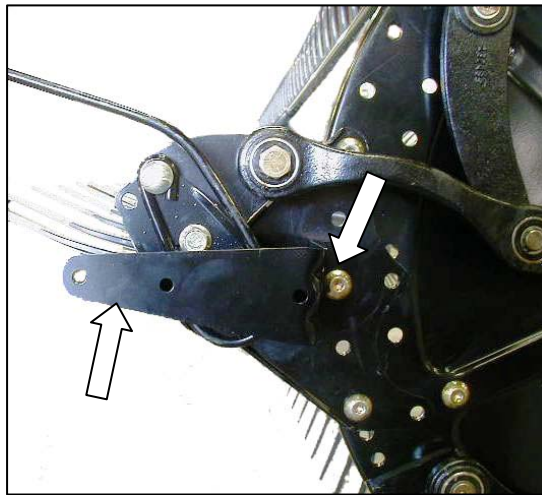

- Loosen bolts securing endshield supports to disc, and rotate supports approximately as shown.
- Retrieve hardware from bag removed in previous step.

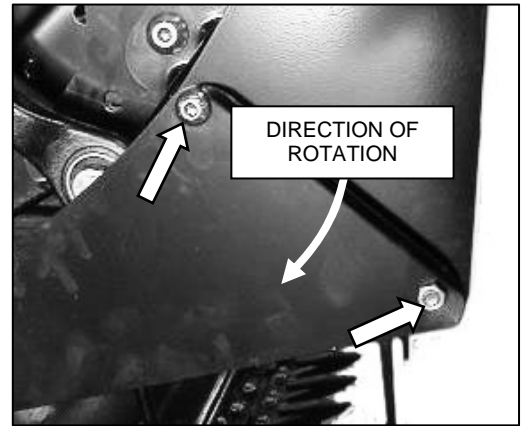

CAM END

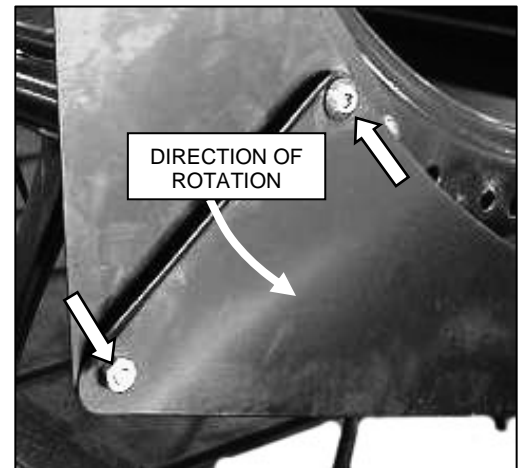

TAIL END

- Install endshields with lip in relation to reel rotation. Use 3/8" x 0.5 long TORX head screws, and torque to 20 ft-lbf (27 N·m). **See above for hardware orientation.**

The jam-nuts must be locking jam-nuts. If they are not locking nuts, use Loctite® #243 (or equivalent).

- Re-tighten endshield support bolts, if necessary.

UNLOADING AND ASSEMBLY

STEP 13. REMOVE SHIPPING SUPPORTS

The removable supports are painted yellow.

NOTE

Unless otherwise specified, discard supports, and all shipping material and hardware.

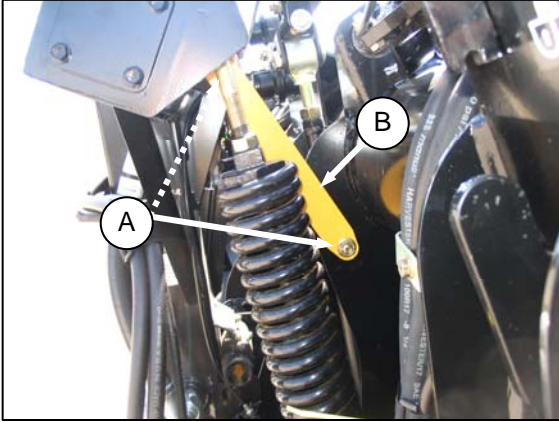

- a. Remove bolts (A), and remove strap (B) from both sides of center frame.

NOTE

If strap is difficult to remove, lift on one end of header to release the load on the strap, so that bolts can be removed.

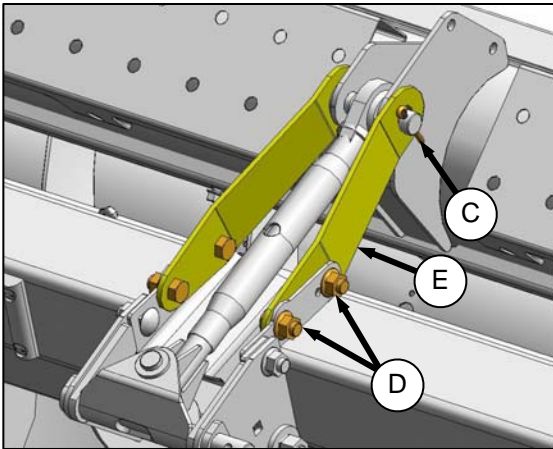

- b. Remove cotter pin (C), bolts (D), and remove shipping strap (E).

NOTE

If hydraulic center-link is installed, there is only one strap.

- c. Re-install cotter pin (C).
d. Repeat for opposite brace.



CAUTION

Reel arms must be level prior to removing reel shipping braces. Failure to do so may result in reel moving suddenly.

- e. Start combine, and level the reel arms with the combine hydraulics.

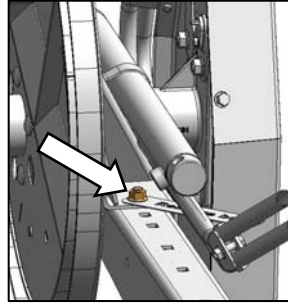

D50 RH ARM

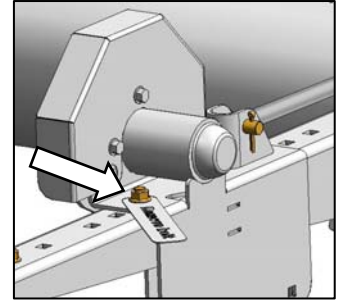

D50 LH ARM

- f. Remove tagged bolts that lock reel bracket assemblies to reel arms. (D50 only).

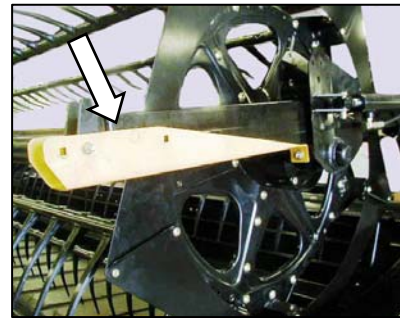

D60 LH ARM

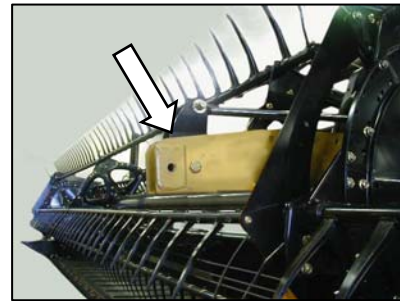

D60 CENTER ARM

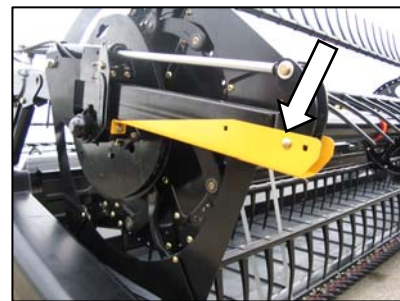

D60 RH ARM

- g. Remove braces on reel arms. (D60 ONLY).

UNLOADING AND ASSEMBLY

STEP 14. INSTALL CROP DIVIDERS

A. D60

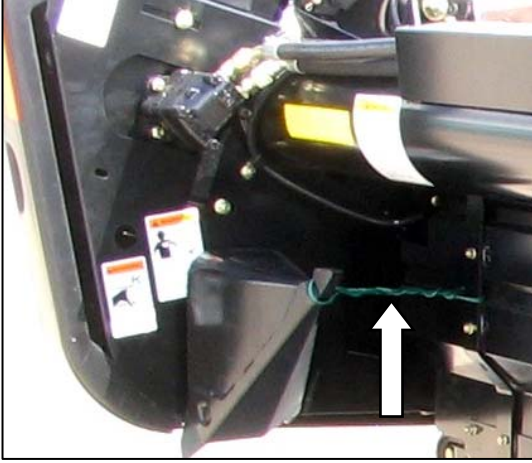

- a. At divider storage location, remove shipping wire from crop divider.

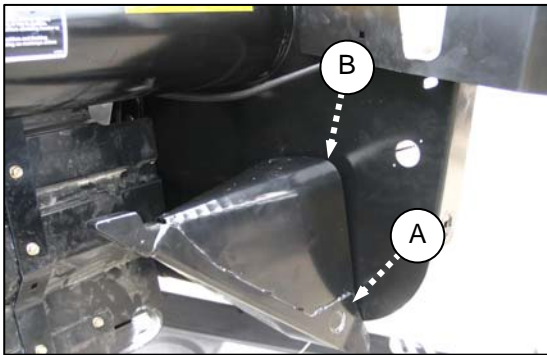

- b. Lift divider to disengage lugs (A) at lower end, and then lower it slightly to disengage pin (B) from endsheet.

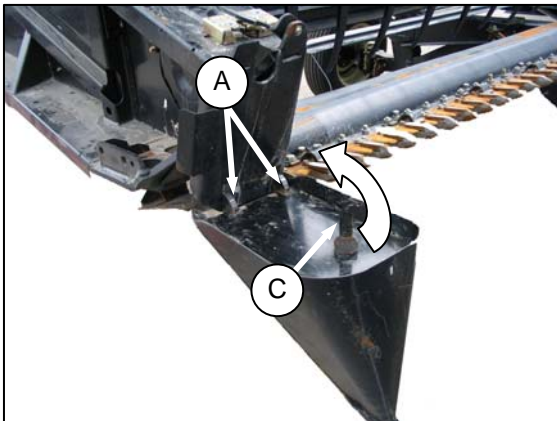

- c. Position crop divider as shown by locating lugs (A) in holes in endsheet.

- d. Lift forward end of divider until pin (C) at top of divider engages and closes latch (D).

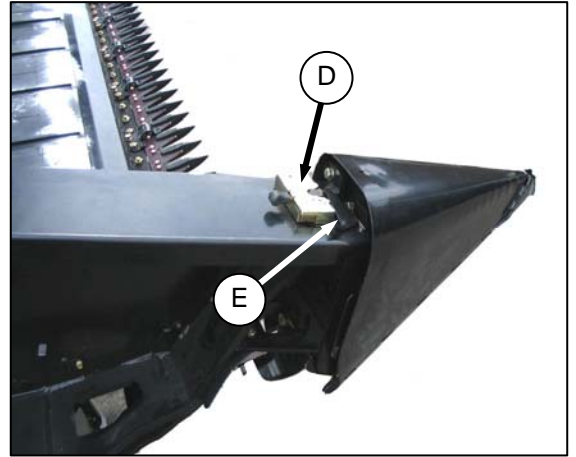

- e. Push safety lever (E) down to lock pin in latch.
f. Check that divider does not move laterally. Adjust bolts (F) as required to tighten divider, and remove lateral play when pulling at divider tip.
g. Remove divider rods from shipping location on header endsheet.

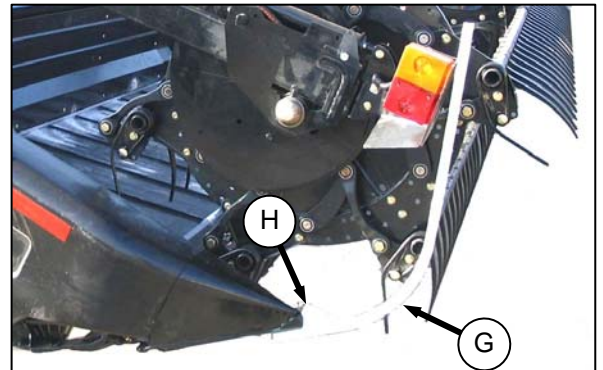

- h. Position divider rod (G) on tip of crop divider as shown, and tighten bolt (H).
i. Repeat above steps for other end of header.

UNLOADING AND ASSEMBLY

B. D50

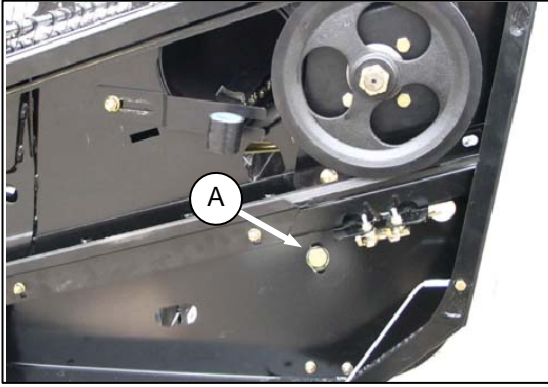

- a. Remove bolt (A), and washer securing crop divider to endsheet.

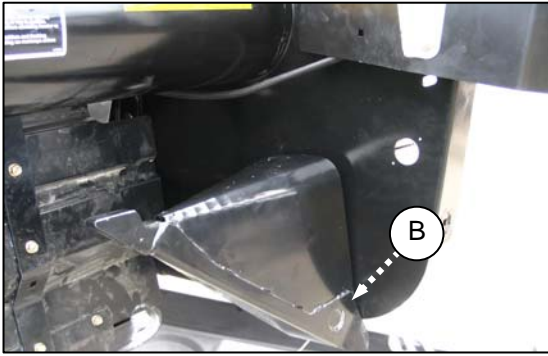

- b. Lift divider to disengage lugs (B) at lower end.

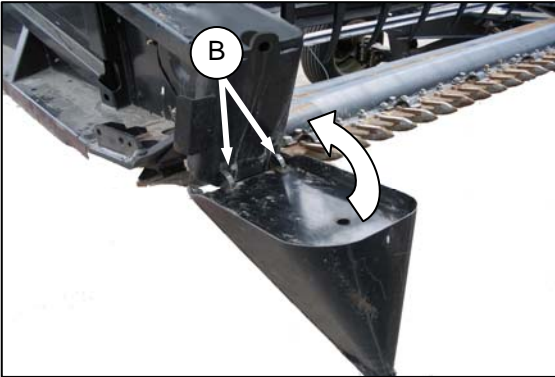

- c. Position crop divider as shown by locating lugs (B) in holes in endsheet forward end, and lift forward end of divider to the face of the endsheet.

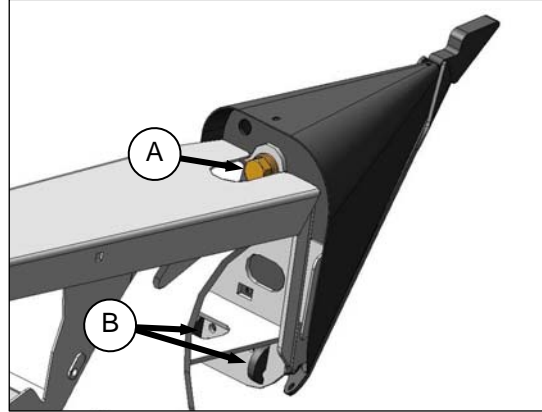

- d. Install bolt (A), lock-washer, and flat washer. Tighten bolt.

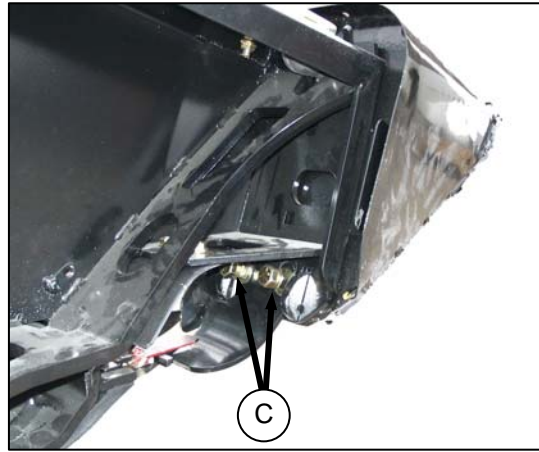

- e. Check that divider does not move laterally. Adjust bolts (C) as required to tighten divider, and remove lateral play when pulling at divider tip.
f. Remove divider rods from shipping location on header endsheet.

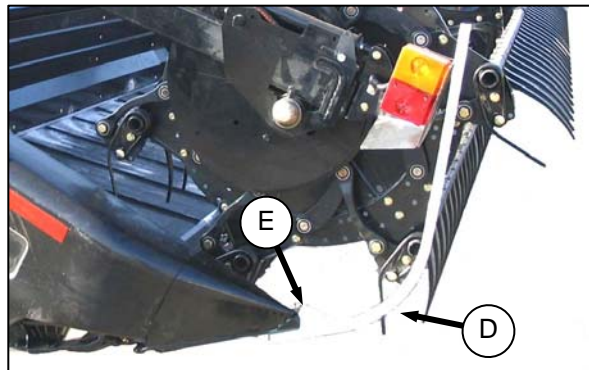

- g. Position divider rod (D) on tip of crop divider as shown, and tighten bolt (E).
h. Repeat above steps for other end of header.

UNLOADING AND ASSEMBLY

STEP 15. INSTALL HEADER ENDSHIELDS



The endshields are banded or wired to the backsheet for shipping.

Remove endshields, and discard shipping material.

Single knife headers are fitted with a hinged endshield on the LH end of the header for easy access to the header drive. The RH end is not hinged, but is still removable.

Double knife headers (DK) are fitted with hinged endshields on both ends of the header.

A. HINGED ENDSHIELD

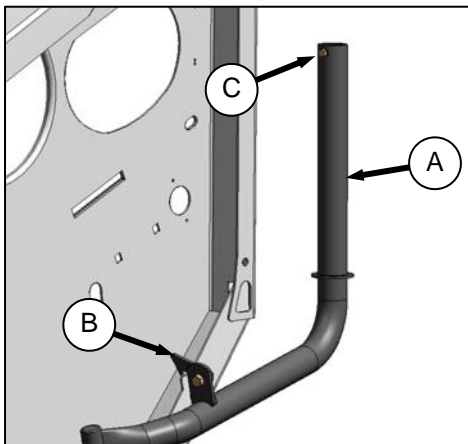

- Remove shipping wire from endshield support (A), and swivel support away from endsheet toward the back of the header until it latches (B).
- Retrieve plastic endshields.
- Remove screw (C) at top of support.

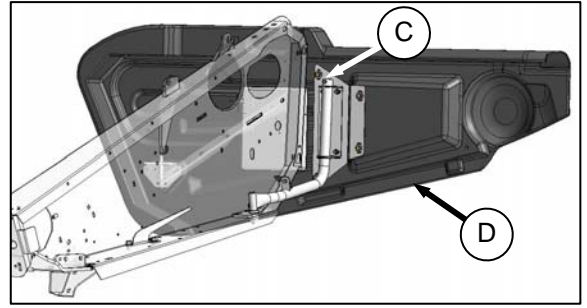

- Install endshield (D) onto support tube, and re-install screw (C).



- To close shield, lift latch (B), and swing the shield forward until the front engages the crop divider (E).
- Push in shield where shown (opposite latch), and shield will self-latch.

NOTE

Plastic endshields are subject to expansion or contraction depending on large temperature variations. Latch pin can be adjusted to compensate for dimensional changes.

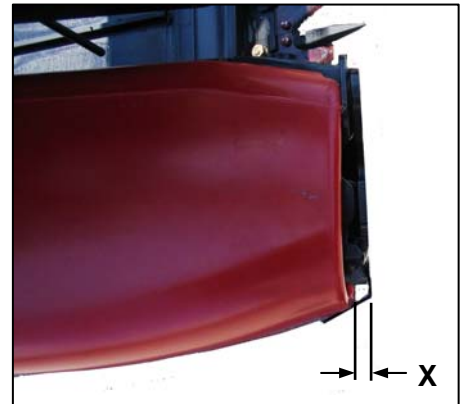

- The endshield should fit snugly onto the endsheet. Check gap 'X' between the front end of the shield and the header frame, and compare the measurement with the values in the chart (next page).

(continued next page)

UNLOADING AND ASSEMBLY

TEMPERATURE Degrees °F (°C)	GAP 'X' in. (mm)
25 (- 4)	1.1 (28)
45 (7)	1.0 (24)
65 (18)	0.79 (20)
85 (29)	0.64 (16)
105 (41)	0.5 (12)
125 (52)	0.32 (8)
145 (63)	0.16 (4)
165 (89)	0

h. If required, adjust as follows:

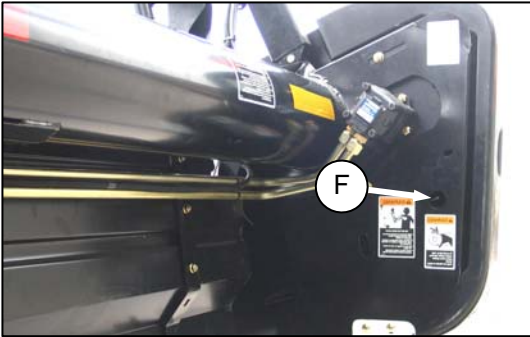

1. Open endshield by pressing against latch in opening at (F) on inboard side of endsheet.

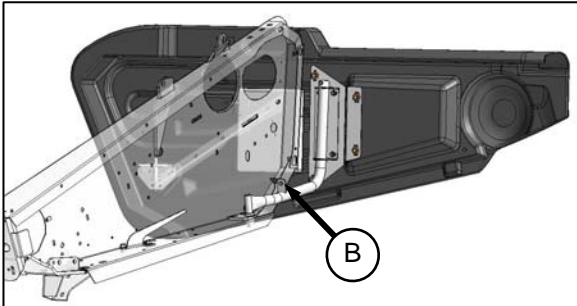

2. Pull shield away from header, and swing it out and back behind the endsheet until the latch (B) engages the hook on the endsheet.

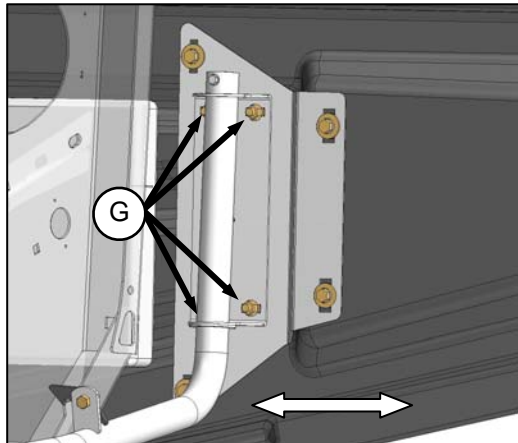

3. Loosen bolts (G) on support (see previous column).

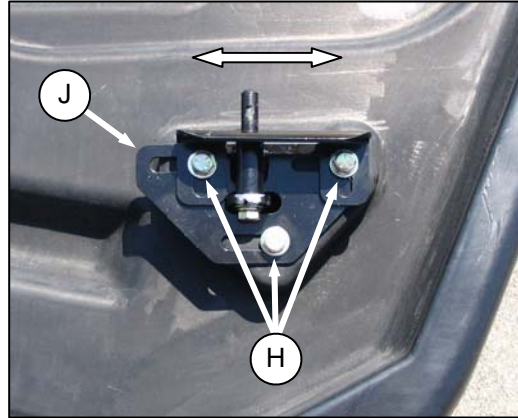

4. Loosen bolts (H) on latch assembly (J).
5. Adjust latch assembly (J) to achieve appropriate gap 'X' in chart (see previous column).
6. Tighten bolts (G) and (H).

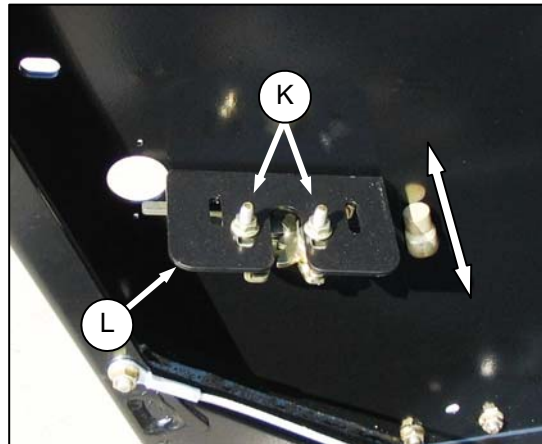
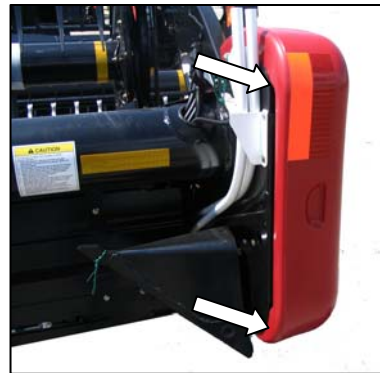

- i. To achieve a snug fit between the aft end of the shield and header frame, loosen bolts (K), and adjust the latch assembly (L) to re-position the shield.

(continued next page)

UNLOADING AND ASSEMBLY

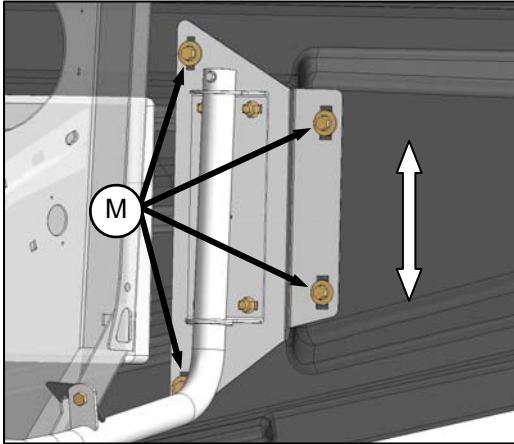

- j. Loosen bolts (M) on endshield support, and adjust endshield to align with endsheet as shown above.
- k. Tighten hinge bolts (K) and bolts (M).
- l. Close endshield.

B. NON-HINGED ENDSHIELD

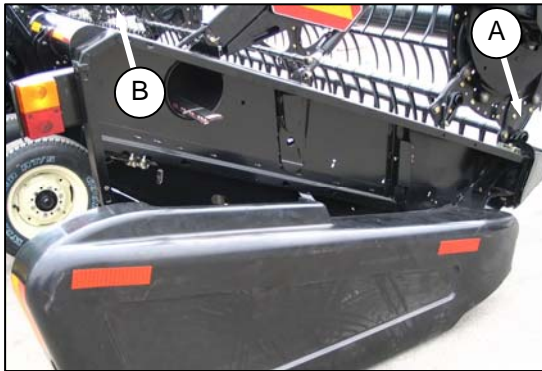

- a. To install the non-hinged shield, locate forward end in crop divider (A), and position shield over endsheet. Pin (B) at top of endsheet must engage shield.



- b. Push shield "in" where shown (opposite latch), and shield will self-latch.

NOTE

Plastic endshields are subject to expansion or contraction depending on large temperature variations. Latch pin can be adjusted to compensate for dimensional changes.

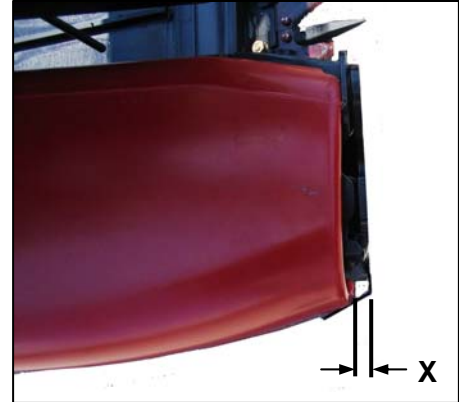

- c. The endshield should fit snugly onto the endsheet. Check gap 'X' between the front end of the shield and the header frame, and compare the measurement with the values in the following chart.

TEMPERATURE Degrees °F (°C)	GAP 'X' in. (mm)
25 (- 4)	1.1 (28)
45 (7)	1.0 (24)
65 (18)	0.79 (20)
85 (29)	0.64 (16)
105 (41)	0.5 (12)
125 (52)	0.32 (8)
145 (63)	0.16 (4)
165 (89)	0

(continued next page)

UNLOADING AND ASSEMBLY

d. If required, adjust as follows:

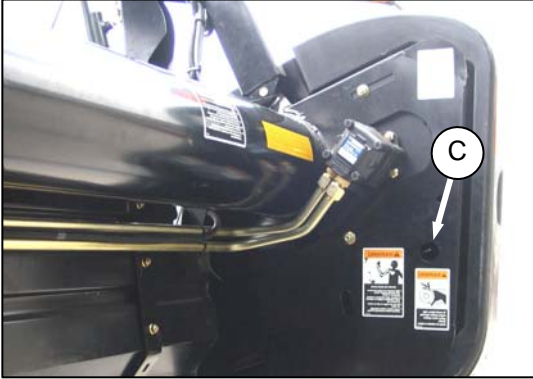

1. Remove the endshield by pressing against latch in opening at (C) on inboard side of endsheet.



2. Lift up on shield, pull out and then back to remove it.

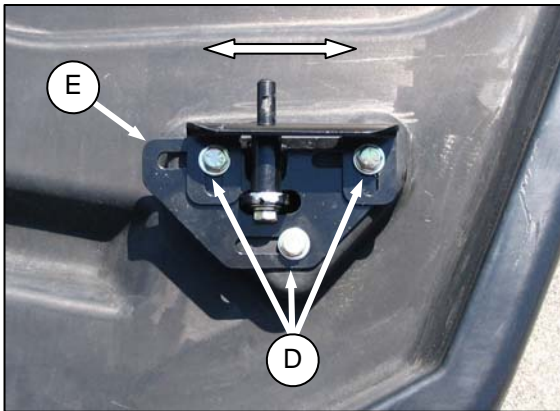

3. Loosen bolts (D).
4. Adjust the pin assembly (E) to achieve the gap 'X' between the front end of the shield and the header frame, in accordance with the chart (on previous page).
5. Tighten bolts (D).

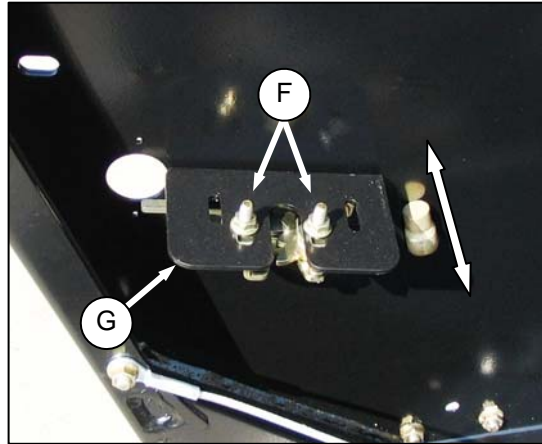

- e. To achieve a snug fit between the aft end of the shield and header frame, loosen bolts (F), and adjust the latch (G) to re-position the shield.
- f. Tighten bolts (F).

STEP 16. POSITION TRANSPORT LIGHTS



Position light perpendicular to header.

Lights are located on each of the outboard reel arms.

PRE-DELIVERY INSPECTION

STEP 17. PRE-DELIVERY INSPECTION

IMPORTANT

To avoid machine damage, check that no shipping dunnage has fallen into machine.

Perform the final checks as listed on the "Pre-Delivery Checklist" (yellow sheet attached to this instruction) to ensure the machine is field-ready.

Refer to the following pages for detailed instructions as indicated on the checklist.

IMPORTANT

The machine has been set at the factory and should require no further adjustments. However, perform the following checks to ensure your machine will provide maximum performance.

Adjustments should be made **only if absolutely necessary**, and in accordance with the instructions in this manual.

The completed checklist should be retained either by the Operator or the Dealer.

A. TIRE PRESSURE (TRANSPORT AND STABILIZER WHEEL OPTIONS)

Check tire inflation pressure.

If necessary, inflate as per following table.

YEAR	TIRE	SIZE	PRESSURE
2006 and EARLIER	GOODYEAR WRANGLER RT/S	205-75 R15	40 psi (276 kPa)
2007 and LATER	CARLISLE and TITAN	ST205/75 R15	65 psi (448 kPa)

IMPORTANT

Do not exceed maximum pressure specified on tire sidewall.

B. WHEEL BOLT TORQUE (TRANSPORT AND STABILIZER WHEEL OPTIONS)

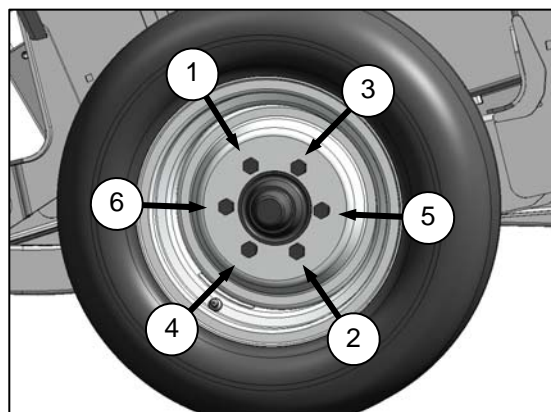

Check wheel bolt torque is 80 - 90 ft·lbf (110-120 N·m). Refer to bolt tightening sequence illustration.

C. WOBBLE BOX

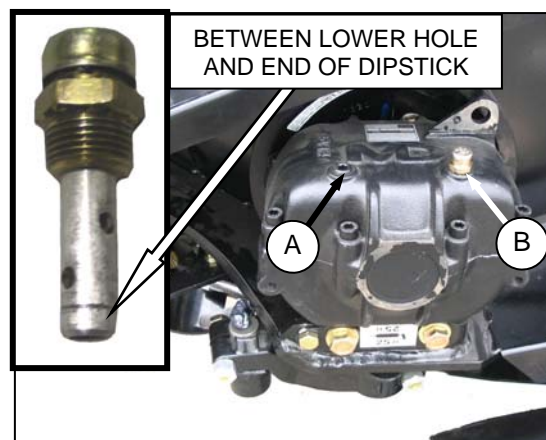

CHECK OIL LEVEL WITH TOP OF WOBBLE BOX HORIZONTAL

- Position of plug (A) and breather (B) at wobble box **must** be as shown.
- Check oil level.

PRE-DELIVERY INSPECTION

D. GEARBOX OIL

- a. Set cutterbar to "working position".

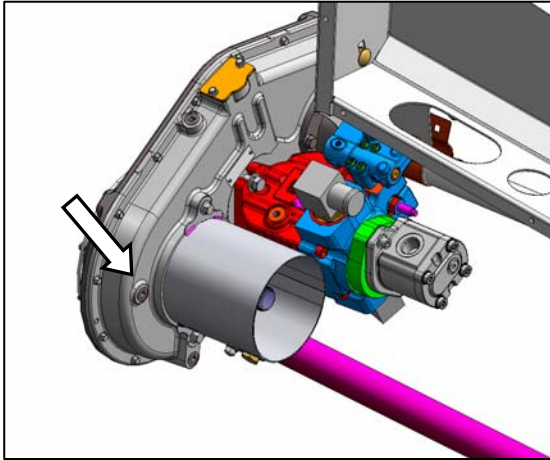

- b. Remove drain plug. Level should be to bottom of drain hole.

E. HYDRAULIC RESERVOIR

- a. Set cutterbar on ground.
- b. Check oil level at sights (A) and (B), with cutterbar just touching ground. Check when oil is cold, and with center-link retracted.

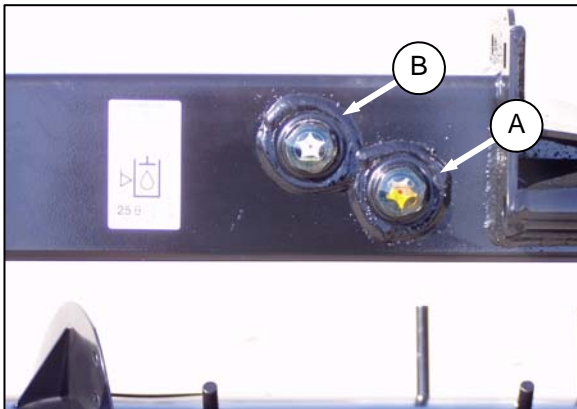

Nominal - Normal Terrain: Maintain level so lower sight (A) is full, and upper sight (B) is empty.

NOTE

When ambient temperatures are above 95°F (35°C), to prevent overflow at breather under operating temperatures, it may be necessary to lower oil level slightly.

F. SICKLE DRIVE BELT TENSION

IMPORTANT

To prolong belt and drive life, do not over-tighten belt.

I. NON-TIMED DRIVE - SK and DK

- a. Open endshield.

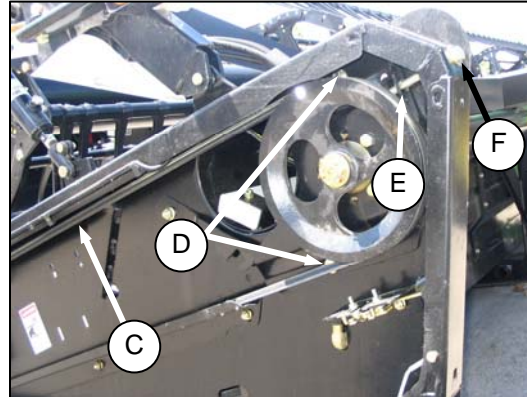

LH SHOWN - RH OPPOSITE

- b. A force of 20 lbf (80 N) should deflect belt (C) 3/4 in. (18 mm) at mid-span.
- c. Only if necessary, adjust tension as follows:
 1. Loosen two bolts (D) on sickle drive mounting bracket, and jam-nut (E).
 2. Turn adjuster bolt (F) to move drive motor until tension is achieved.
 3. Tighten jam-nut (E) and bolts (D) on drive mounting bracket.
- d. Close endshield.

(continued next page)

PRE-DELIVERY INSPECTION

II. TIMED DRIVE - DK

a. Open endshield.

Timing Belts



LH SHOWN - RH OPPOSITE

1. A force of 6 lbf (27 N) should deflect timing belt (G) 1/2 in. (13 mm) at mid-span.
2. Only if necessary, adjust tension as follows:

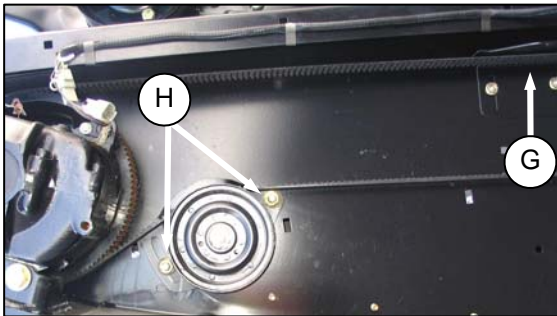

LH SHOWN - RH OPPOSITE

- i. Loosen two nuts (H) on sickle drive belt idler bracket.

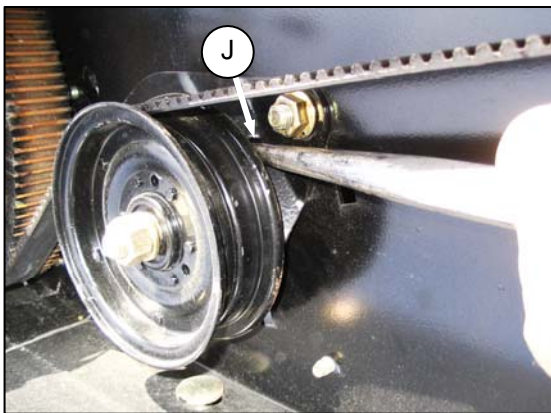

- ii. Insert a long punch or equivalent into hole (J) in idler bracket, and pry "downward" until a force of 6 lbf (27 N) deflects timing belt 1/2 in. (13 mm) at mid-span (G).
- iii. Tighten nuts (F) on idler mounting bracket.

Double V-Belts - LH Side Only

1. A force of 12 lbf (53 N) should deflect V-belts (K) 1/8 in. (3 mm) at mid-span.
2. Only if necessary, adjust tension as follows:

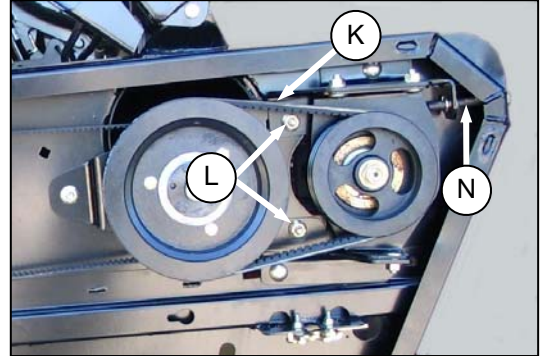

LH SIDE ONLY

- i. Loosen two bolts (L) on sickle drive mounting bracket.

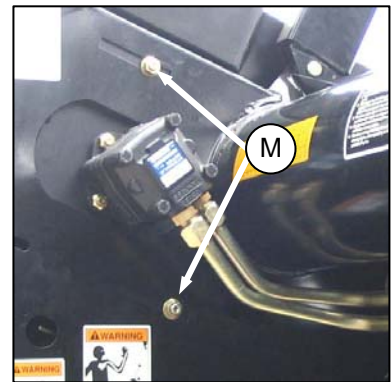

- ii. Loosen two bolts (M) on endsheet.
- iii. Turn adjuster bolt (N) to move drive motor until a force of 12 lbf (53 N) deflects V-belts (K) 1/8 in. (3 mm) at mid-span.
- iv. Tighten bolts (L) and (M).

PRE-DELIVERY INSPECTION

G. REEL CENTERING



WARNING

Stop combine engine, and remove key before making adjustments to machine. A child or even a pet could engage the drive.

- a. Measure clearance between reels and both endsheets. The clearances should be the same if the reels are centered.
- b. If required center the reels as follows:

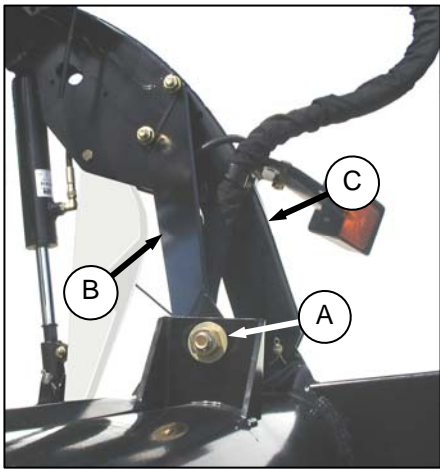

D60

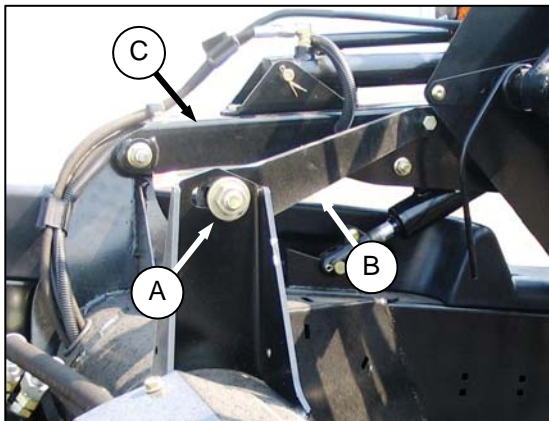

D50

1. Loosen bolt (A) on each brace (B) located at each end of the reel.
2. Move forward end of reel support arm (C) laterally as required to center reel.
3. Tighten bolts (A), and torque to 265 ft·lbf (359 N·m).

PRE-DELIVERY INSPECTION

H. SIDE DRAPER TENSION

The drapers are tensioned after installation at the factory, so should not require adjustment.

Draper tension should be just enough to prevent slipping, and keep draper from sagging below cutterbar. The white indicator bar (A) (shown in the next column) should be "about halfway" in the window.

- a. Raise header, and shut down engine. Engage header lift props.



WARNING

Stop combine engine, and remove key before making adjustments to machine. A child or even a pet could engage the drive.



CAUTION

Engage header lift cylinder stops before working under header.

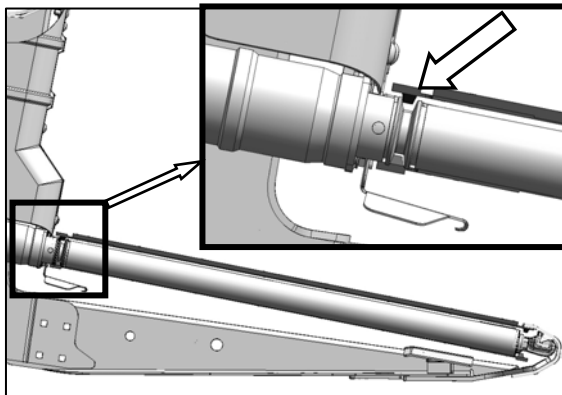

DRIVE ROLLER

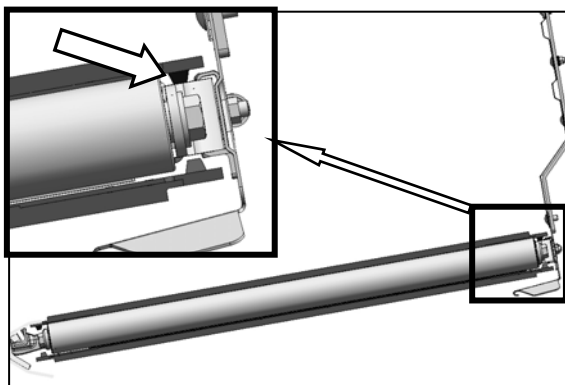

IDLER ROLLER

- b. Check that draper guide (rubber track on under-side of draper) is properly engaged in groove of drive roller, and that idler roller is "between" the guides.

- c. If required, set draper tension as follows:

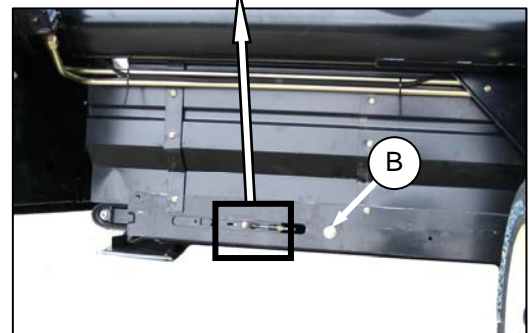
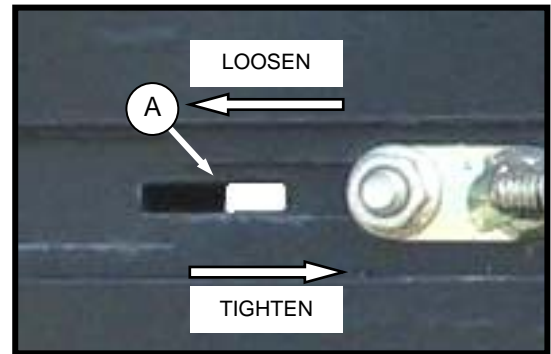

1. Turn bolt (B) clockwise (tighten), and white indicator bar (A) will move inboard in direction of arrow to indicate that draper is tightening.
2. Turn bolt (B) counter clockwise (loosen), and white indicator bar (A) will move outboard in direction of arrow to indicate that draper is loosening.
3. Adjust until bar is "about halfway" in window.

IMPORTANT

To avoid premature failure of draper, draper rollers and/or tightener components, do not operate with tension set so that white bar is not visible.

Also to prevent the draper from scooping dirt, ensure draper is tight enough that it does not sag below point where cutterbar contacts the ground.

PRE-DELIVERY INSPECTION

I. HEADER MAIN FLOAT

Checking and Adjusting Float



CAUTION

Stop engine, and remove key from ignition before leaving Operator's seat for any reason. A child or even a pet could engage an idling

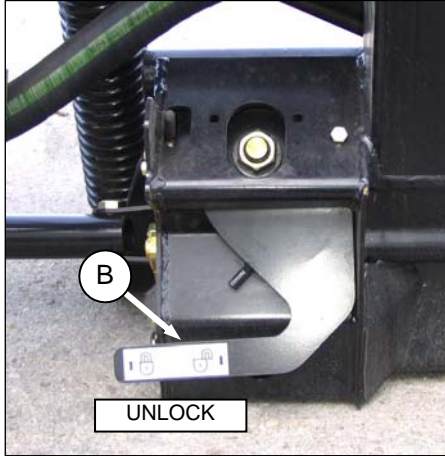

machine.

- a. Ensure both header float lock levers (B) are

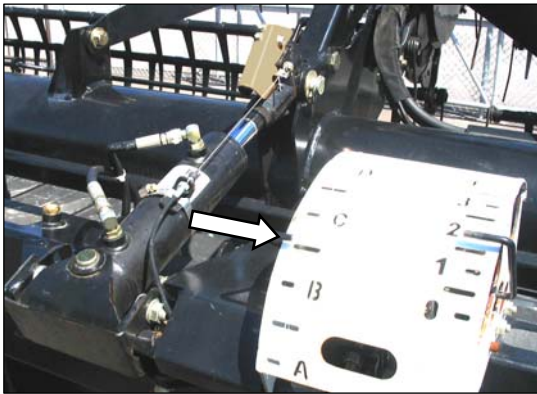

down (UNLOCK).

- b. Set center-link to mid-range (B to C on float/angle indicator if installed). Adjust cutterbar to 6 - 10 inches (150 - 250 mm) above the ground.
- c. If header is equipped with stabilizer wheels or slow speed transport wheels, raise them off the ground so they are supported by the header.

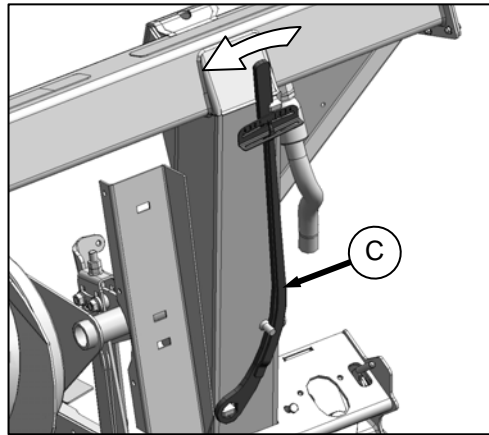

- d. Remove supplied torque wrench (C) from storage position at RH side of adapter frame. Pull slightly in direction shown to disengage wrench from hook.

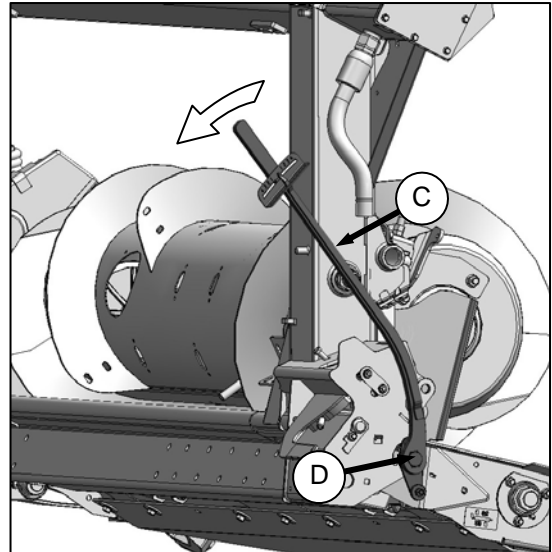

RIGHT SIDE - BELL CRANK NOT SHOWN

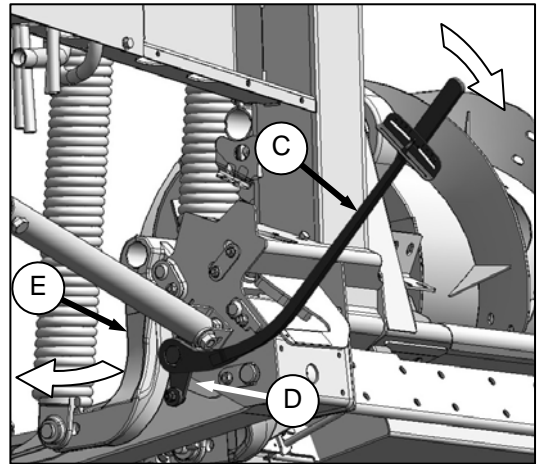

LEFT SIDE

- e. Place supplied torque wrench (C) onto float setting indicator (D). Note position of wrench for checking RH or LH side.

(continued next page)

PRE-DELIVERY INSPECTION

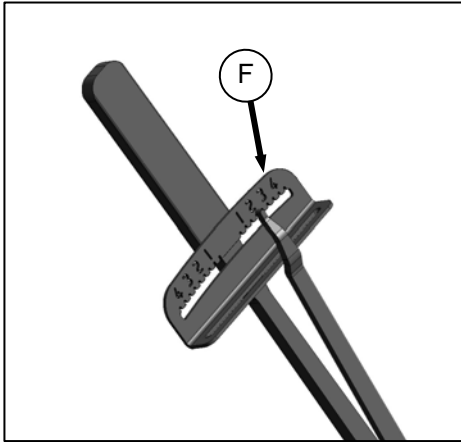

- f. Push down on wrench until bell crank (E) rotates forward. Check the position of the wrench indicator (F) near the handle. Repeat for opposite side.
- g. Use the table below as a guide for float settings:

HEADER WIDTH	TORQUE SETTINGS	
	CUTTING ON THE GROUND	CUTTING OFF THE GROUND
20, 25, 30 and 35 FT	2	2 1/2
40 and 45 FT	2 1/2	3

- h. If excessive force is required, or header does not return to its original position, float requires adjusting.



LEFT SIDE FLOAT

RIGHT SIDE FLOAT

- **To increase float** (lighten the header), tighten bolts (H) and (J) at both sides of adapter.
- **To decrease float** (increase header weight), loosen the bolts (H) and (J).

IMPORTANT

Turn each bolt pair equal amounts. After adjustment has been made, refer to Checking and Adjusting Float on previous page.

NOTE

Loosening the bolts increases header weight and decreases float.

Tightening the bolts lightens the header and increases float.

IMPORTANT

Proper float adjustment in accordance with the above is critical to maintain proper wing balance when cutting on the ground.

IMPORTANT

To avoid frequent breakage of sickle components, scooping soil, or soil build-up at cutterbar in wet conditions, header float should be set as light as possible without causing excessive bouncing.

When float setting is light, it may be necessary to use a slower ground speed to avoid excessive bouncing and leaving a ragged cut.

IMPORTANT

Stabilizer wheels may be used in conjunction with main float to minimize bouncing at the header ends and control cut height when cutting off the ground.

NOTE

If adequate header float cannot be achieved using all of the available adjustments, an optional heavy duty spring is available. It includes an inner spring. See your MacDon Dealer or Parts Catalog for ordering information.

NOTE

Header angle and reel fore-aft position changes do not significantly affect header float (down force).

PRE-DELIVERY INSPECTION

J. SKID SHOE SETTINGS



WARNING

Stop combine engine, and remove key before making adjustments to machine. A child or even a pet could engage the drive.



CAUTION

Engage header lift cylinder stops before working under header.

- a. Note the hole positions on the adjuster legs (A) on each skid shoe. They should be the same.
- b. If necessary, adjust as follows:

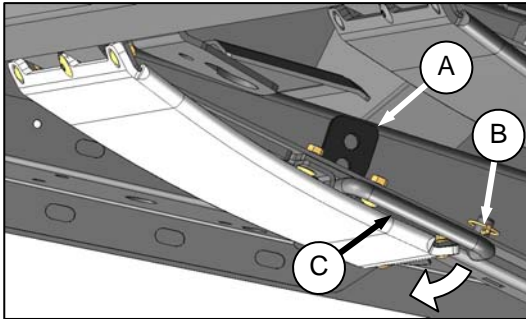

INNER SKID SHOE

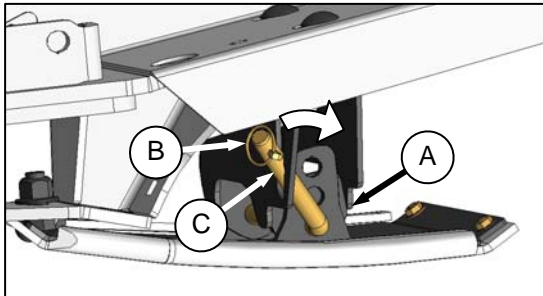

OUTER SKID SHOE

1. Remove lynch pin (B).
2. Hold shoe, and remove pin (C) by disengaging frame, and then pulling away from shoe.
3. Raise or lower skid shoe to desired position using holes in support as a guide.
4. Re-insert pin (C), engage in frame, and secure with lynch pin (B).
5. Check that skid shoes are adjusted to the same position.

PRE-DELIVERY INSPECTION

K. REEL TINE TO CUTTERBAR CLEARANCE

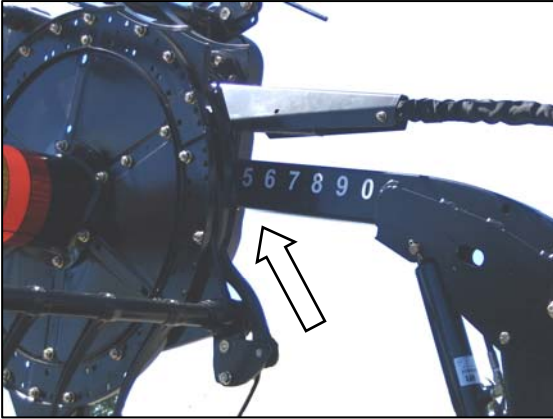

- a. Adjust fore-aft reel position so that back end of cam disc is approximately between 4 and 5 on the arm decal, and fully lowered.

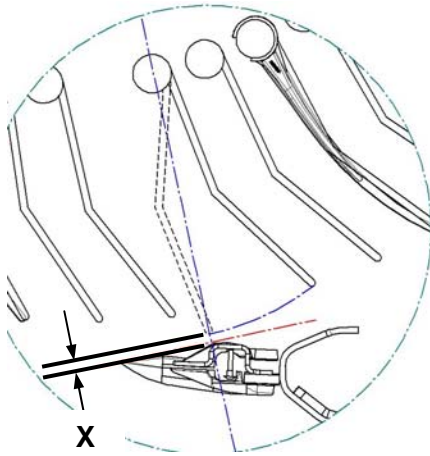

- b. Rotate reel manually to determine which finger is closest to cutterbar (within 12 in. (300 mm)) of endsheets.
- c. Flex fingers back as shown to check clearance 'X'. Refer to chart for allowable clearances.

'X' +/- 0.12 in. (3 mm) At Endsheets	'X' +/- 0.12 in. (3 mm) At Sectors Next to Drive At Center Arm
0.78 in. (20 mm)	1.56 in. (40 mm)

- d. If required, adjust outside reel arms as follows:

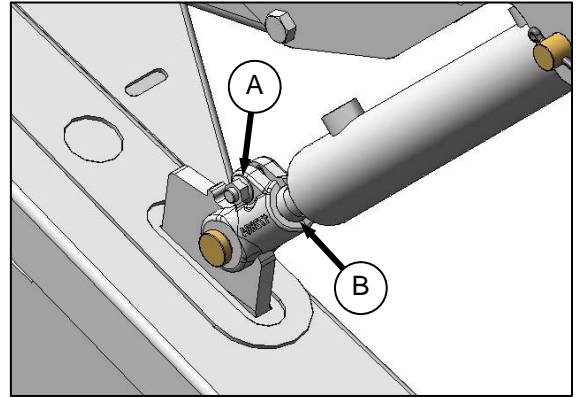

1. Loosen bolt (A).
2. Turn cylinder rod (B) counter clockwise to raise reel and increase clearance to cutterbar, or clockwise to decrease.
3. Tighten bolt (A).
4. Repeat at opposite side.

- e. If applicable, adjust center arm as follows:

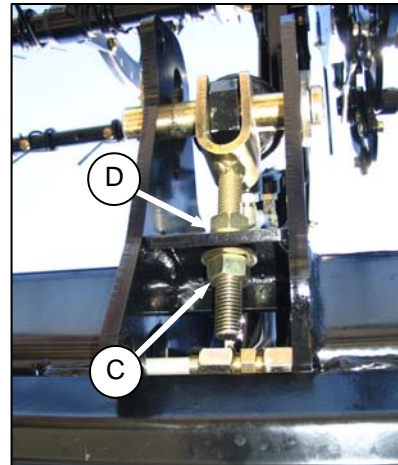

DOUBLE REEL - LOOKING UP
AT ARM UNDERSIDE

1. Loosen nut (C).
2. Turn nut (D) clockwise to raise reel and increase clearance to cutterbar, or counter clockwise to decrease.
3. Tighten bolt (C).

PRE-DELIVERY INSPECTION

L. DRAPER SEAL

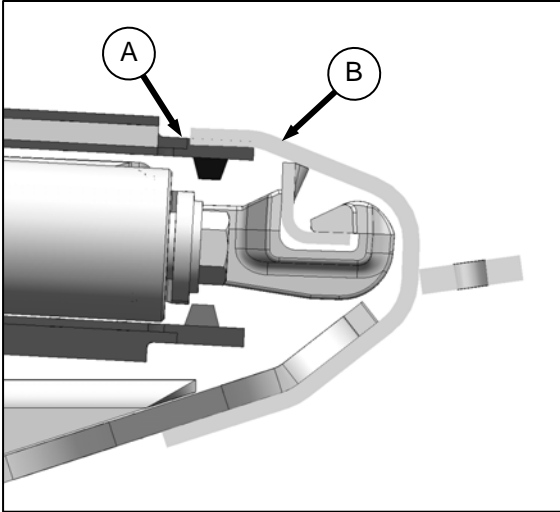

- e. Tap deck (E) to lower deck relative to supports to achieve setting recommended above. Tap support (D) using a punch to raise deck relative to support.
- f. Tighten deck support hardware (C).
- g. Tension drapers. Refer to sub-step **H. SIDE DRAPER TENSION.**

- a. Check deck height so that draper (A) runs just below cutterbar (B) with maximum 1/32 in. (1 mm) gap, or with draper deflected down slightly (up to 1/16 in. (1.5 mm)) to create a seal.

NOTE

Measurement is at supports with header in working position and decks slid fully ahead.

- b. Loosen tension on drapers. Refer to sub-step **H. SIDE DRAPER TENSION.**

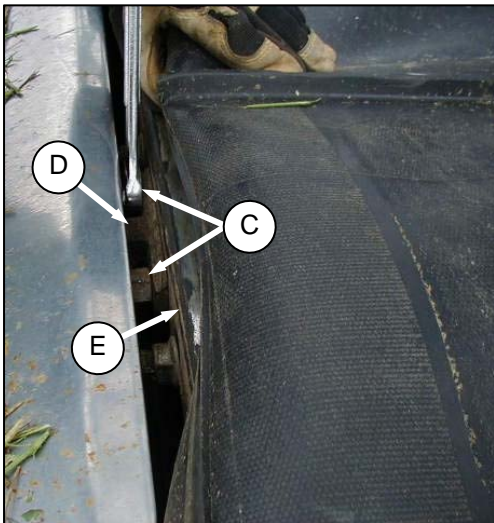

- c. Lift draper up at front edge past cutterbar.
- d. Loosen two locknuts (C) a half-turn only on deck support (D). There are two to four supports per deck, depending on header size.

PRE-DELIVERY INSPECTION

M. LUBRICATE HEADER

Refer to the illustrations for lubrication points:

- Wipe grease fitting with a clean cloth before greasing, to avoid injecting dirt and grit.
- Inject grease through fitting with grease gun until grease overflows fitting, except where noted.
- Leave excess grease on fitting to keep out dirt.
- Replace any loose or broken fittings immediately.
- If fitting will not take grease, remove and clean thoroughly. Also clean lubricant passageway. Replace fitting if necessary.
- Use clean High Temperature Extreme Pressure grease as shown.

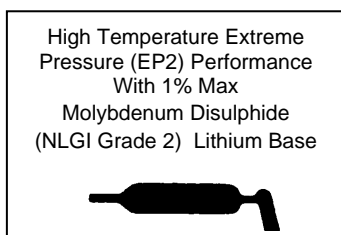

KNIFE DRIVE BEARING - DK
(BOTH SIDES)

D60

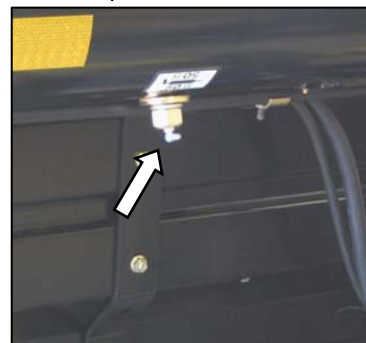

KNIFE DRIVE SHAFT - DK
15 PUMPS MINIMUM
(BOTH SIDES)

PRE-DELIVERY INSPECTION

High Temperature Extreme Pressure (EP2) Performance With 1% Max Molybdenum Disulphide (NLGI Grade 2) Lithium Base



D60

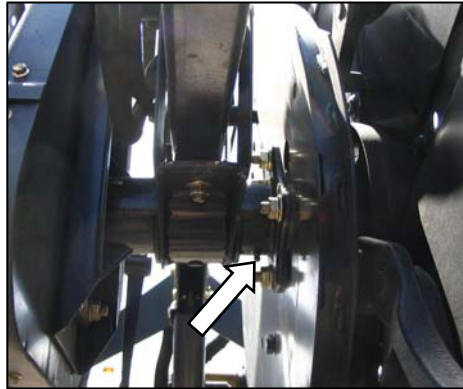

REEL CENTER BEARING (1 PLC)
DOUBLE REEL ONLY

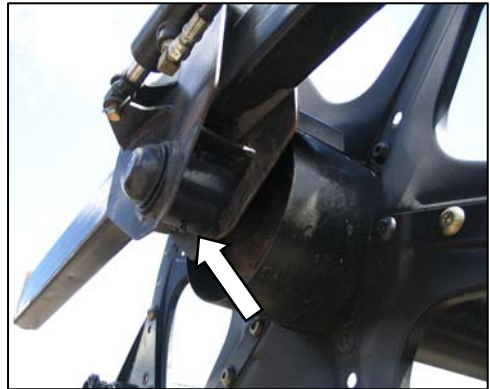

REEL SHAFT LH BEARING (1 PLC)

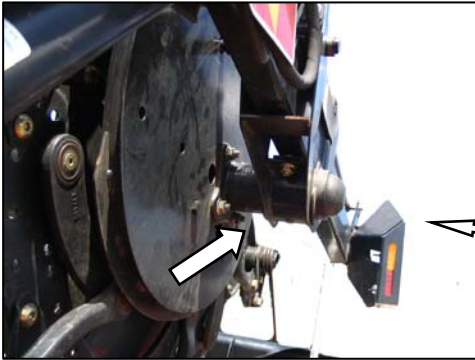

REEL SHAFT RH BEARING (1 PLC)

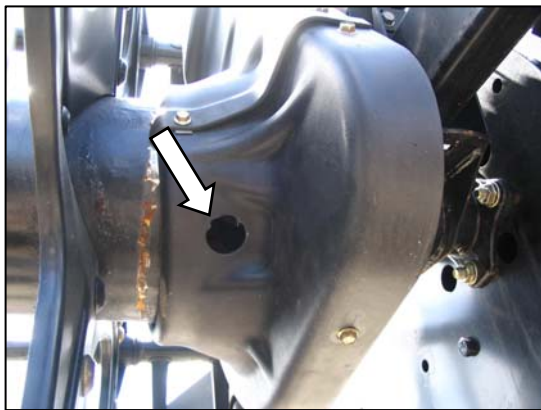
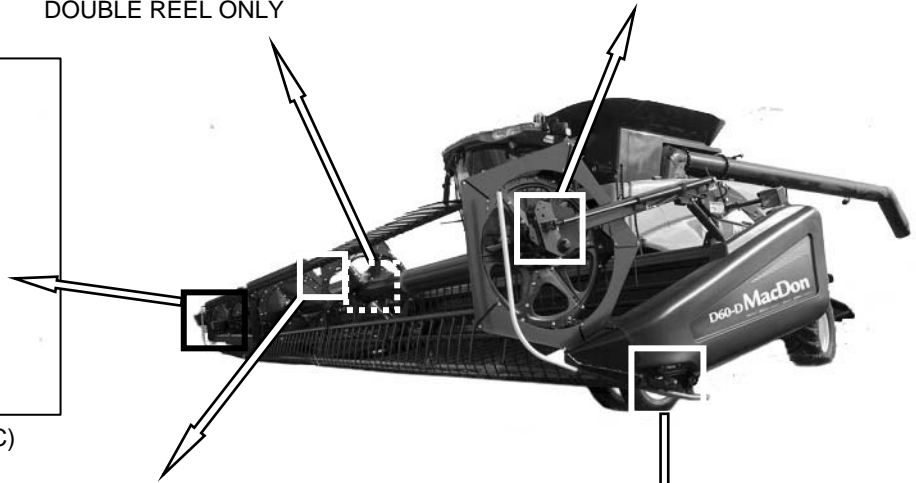

REEL UNIVERSAL (1 PLC) DOUBLE REEL



SICKLE HEAD
(1 PLC SINGLE KNIFE / 2 PLCS DOUBLE KNIFE)

NOTE

*U-joint has an extended lubrication cross and bearing kit. Stop greasing when greasing becomes difficult, or if U-joint stops taking grease. **Overgreasing will damage U-joint.** 6 - 8 pumps are sufficient at first grease (factory). Decrease grease interval as U-joint wears and requires more than 6 pumps.*

NOTE

To prevent binding and/or excessive wear caused by sickle pressing on guards, do not over-grease. If more than 6 to 8 pumps of the grease gun are required to fill the cavity, replace the seal in the sickle head.

(continued next page)

PRE-DELIVERY INSPECTION

High Temperature Extreme Pressure (EP2) Performance With 1% Max Molybdenum Disulphide (NLGI Grade 2) Lithium Base

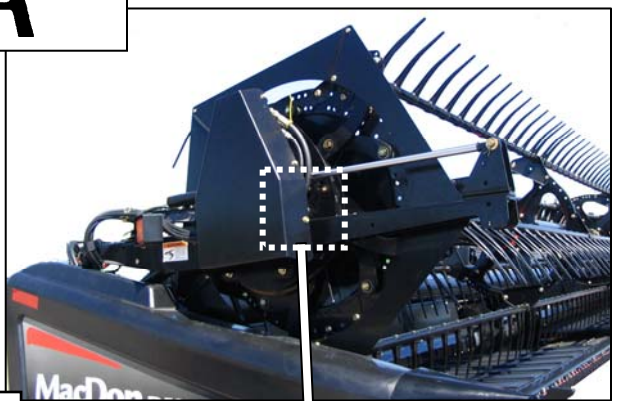
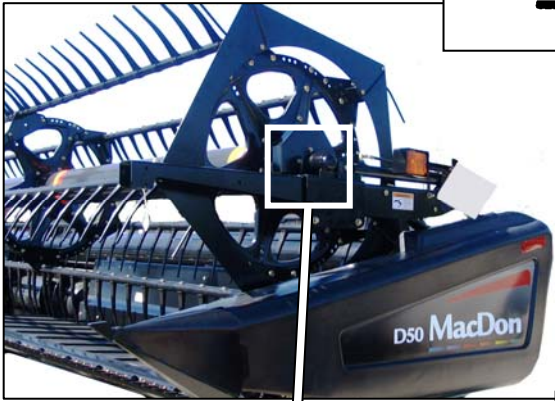

D50

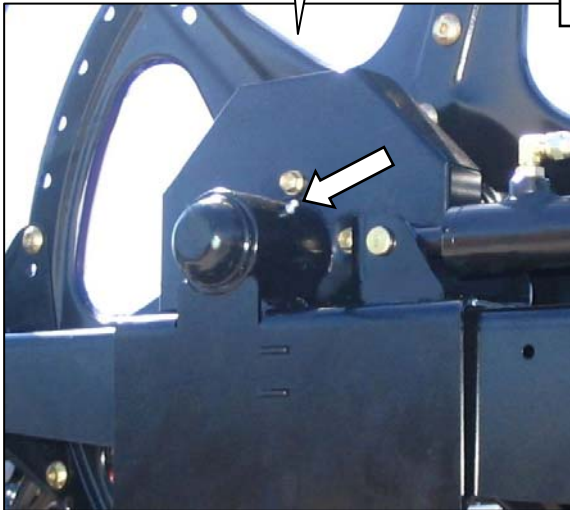

REEL SHAFT LH BEARING (1 PLC)

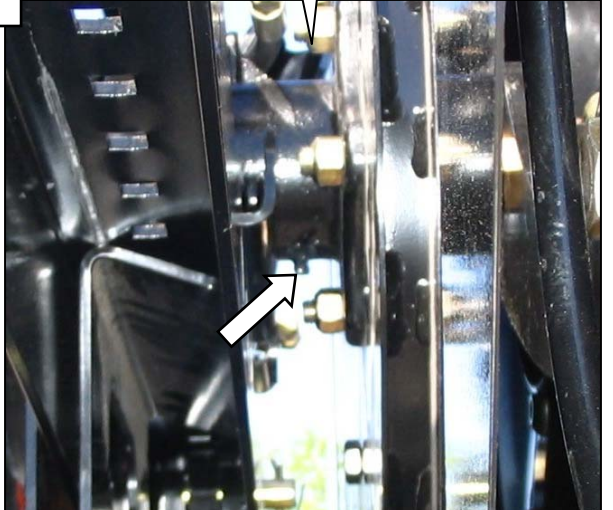

REEL SHAFT RH BEARING (1 PLC)



SICKLE HEAD (1 PLC)



NOTE

To prevent binding and/or excessive wear caused by sickle pressing on guards, do not over-grease. If more than 6 to 8 pumps of the grease gun are required to fill the cavity, replace the seal in the sickle head.

PRE-DELIVERY INSPECTION

High Temperature Extreme Pressure (EP2) Performance With 1% Max Molybdenum Disulphide (NLGI Grade 2) Lithium Base



CA20 ADAPTER

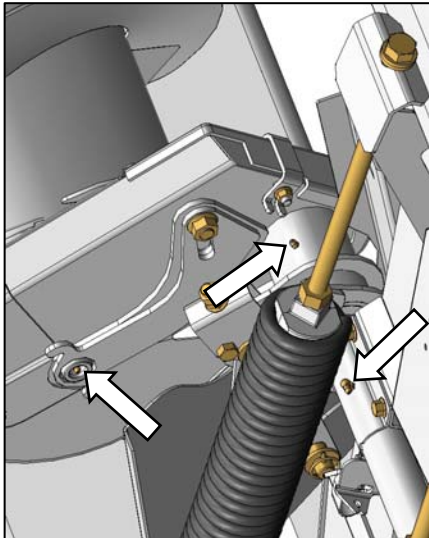

AUGER DRIVE (2 PLCS) AND PIVOT

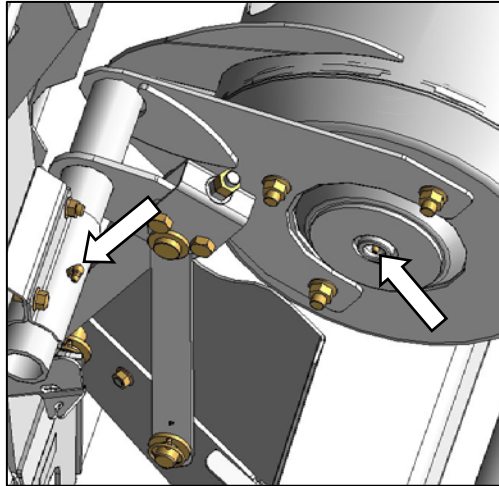

AUGER BEARING AND PIVOT



DRIVE UNIVERSAL - (2 PLCS)

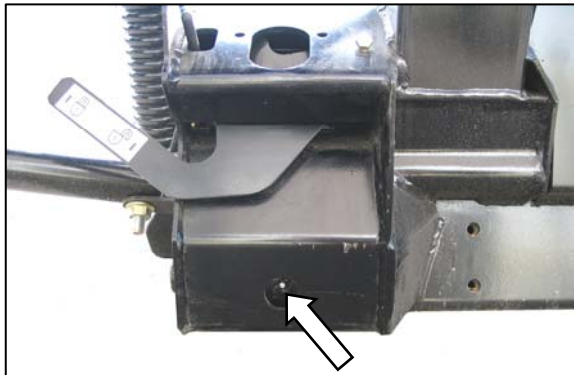
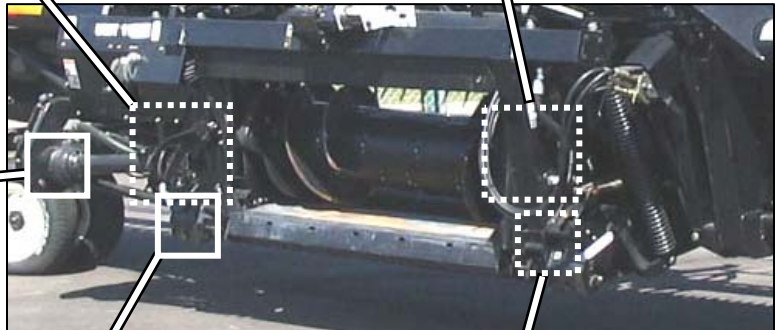

FLOAT PIVOT - BOTH SIDES

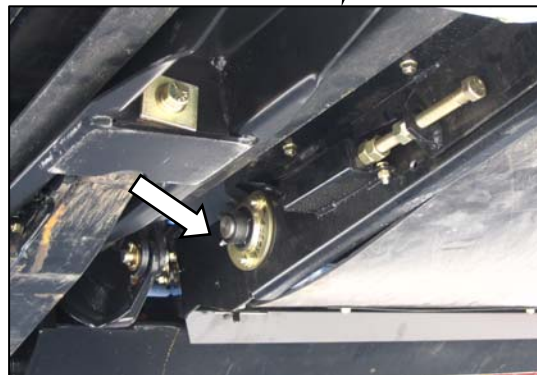

DRIVE ROLLER BEARING (1 PLC)

PRE-DELIVERY INSPECTION

N. MANUALS

- a. Open the left endshield, and remove plastic tie on manual case.

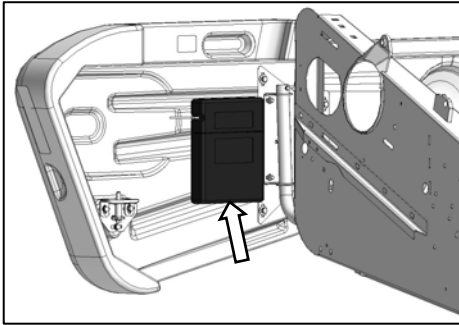

- b. Check that case contains the following manuals:

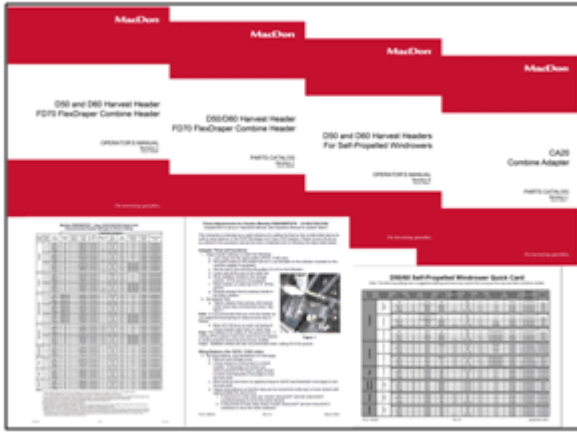

DESCRIPTION	TYPE	FORM
D50 and D60 Harvest Headers for Self-Propelled Windrowers	Operator's Manual	169441
D50 and D60 Harvest Header, FD70 FlexDraper Combine Header	Operator's Manual	169006
D50/D60 Harvest Header, FD70 FlexDraper Combine Header	Parts Catalog	169008
CA20 Combine Adapter	Parts Catalog	169011
MacDon D50/D60/FD70	Quick Card	169234
MacDon D50/D60 SP Draper Header	Quick Card	169406

- c. Close case and endshield.

RUN-UP ADJUSTMENTS AND CHECKS

STEP 18. RUN-UP THE HEADER

- a. Start combine, raise header fully, and engage header lift cylinder locks. Shut down combine, and remove key.



WARNING

Stop combine engine, and remove key before making adjustments to machine. A child or even a pet could engage the drive.



CAUTION

Engage header lift cylinder stops before working under header.

- b. Lower poly pan under adapter, and check for shipping materials/debris that may have fallen under adapter draper as follows:

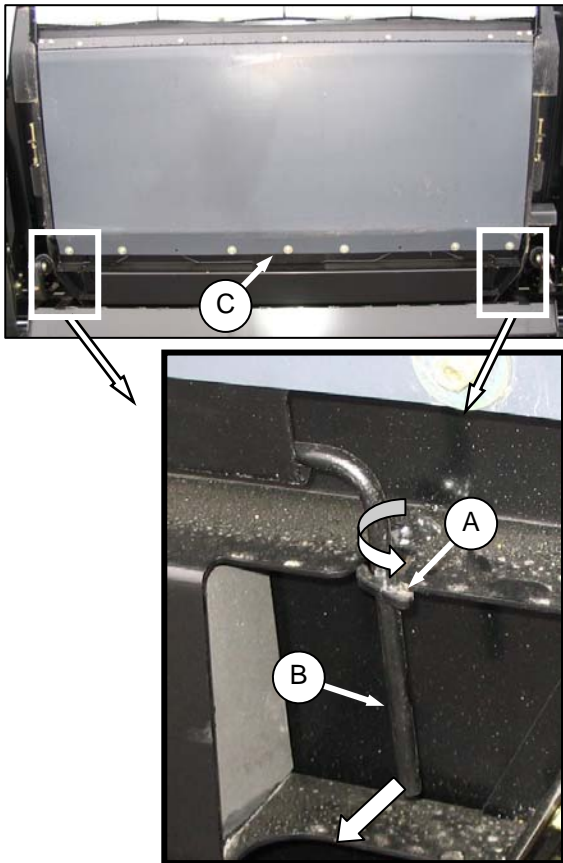

1. Rotate latches (A) to unlock handle (B).

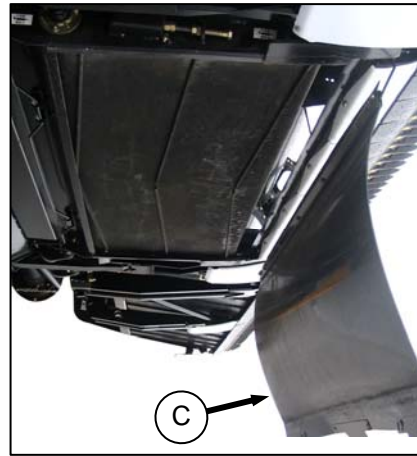

2. Hold pan (C), and rotate handle (B) to release pan. Lower pan to expose draper.
3. Check and remove debris from pan and draper.

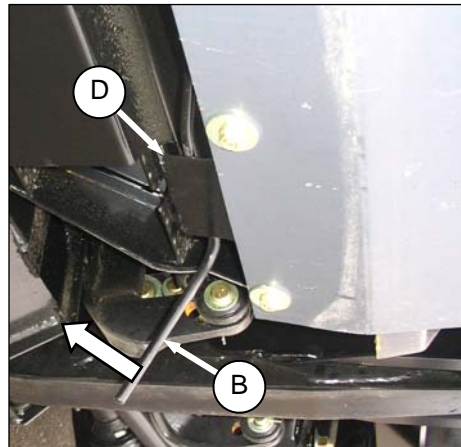

4. Raise pan, and rotate handle (B) so that rod engages clips (D) on pan.

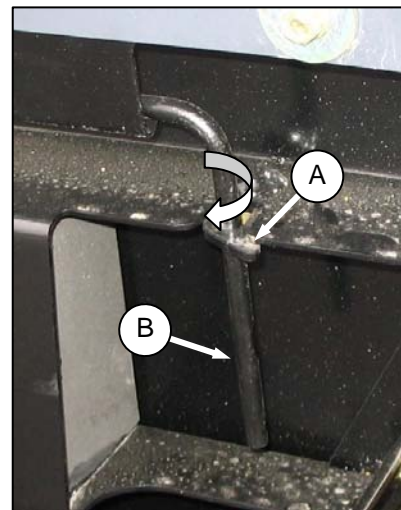

5. Push handle into slot, and secure with latches (A).

(continued next page)

RUN-UP ADJUSTMENTS AND CHECKS



CAUTION

Never start or move the machine until you are sure all bystanders have cleared the area.



CAUTION

Clear the area of other persons, pets etc. Keep children away from machinery. Walk around the machine to be sure no one is under, on or close to it.



CAUTION

Before investigating an unusual sound or attempting to correct a problem, shut off engine, engage parking brake, and remove key.



- c. Open side draper flow control 2 turns.
- d. Ensure feeder house variable speed is set to minimum.
- e. Open the LH endshield.

NOTE

Reel and side drapers will not operate until oil flow fills the lines.

- f. Start combine, and run the machine at operating speed for 15 minutes. Run the header slowly for the first 5 minutes, watching and listening FROM THE OPERATOR'S SEAT for binding or interfering parts.

A. KNIFE SPEED

The header knife drive is driven by the adapter mounted hydraulic pump. Knife drive speed is factory-set for a feeder house speed of 575 rpm for CNH and John Deere adapters, and 780 rpm for AGCO and Lexion adapters.

IMPORTANT

For variable speed feeder houses, this will be the **minimum** speed setting.

To operate variable speed feeder house at greater than minimum speed, flow to knife drive motor must be reduced to prevent excessive speeds which could result in premature knife failure.



- a. Have someone check rpm of the wobble box pulley using a hand held tachometer.
- b. Shut down the combine.
- c. Compare actual pulley rpm with the values in the following chart:

Header Size	Recommended Knife Drive Speed Range (RPM)	
	Single Knife	Double Knife
25 FT	550 - 675	600 - 800
30 FT	550 - 650	600 - 725
35 FT	550 - 600	550 - 700
40 FT	525 - 600	550 - 650
45 FT	N/A	

- d. If adjustment to wobble box pulley rpm is necessary, contact your MacDon Dealer or refer to D60/FD70/CA20 Technical Manual.
- e. Perform run-up check as listed on **Pre-Delivery Checklist** (yellow sheet attached to this instruction) to ensure the machine is field-ready.

RUN-UP ADJUSTMENTS AND CHECKS

STEP 19. POST RUN-UP ADJUSTMENTS

The following adjustments may be necessary after the run-up.



WARNING

Stop combine engine, and remove key before making adjustments to machine. A child or even a pet could engage the drive.



DOWNWARD ADJUSTMENT

A. KNIFE

- a. Check guards for signs of heating during run-up due to insufficient clearance between guard and sickle.
- b. If heating is evident, proceed as follows:



1. Check gap between knife head and pitman arm. A business card should slide easily through the gap. If not, then adjust gap by loosening bolt, and tapping knife head with a hammer. Re-tighten bolt.
2. Adjust guard alignment as follows: The guard straightening tool (MacDon #140135) is available from your MacDon Dealer:



UPWARD ADJUSTMENT

- i. To adjust guard tips upwards, position tool as shown, and pull "up".

- ii. To adjust tips downward, position tool as shown, and push "down".

NOTES

MacDon™

MacDon Industries Ltd.

680 Moray Street
Winnipeg, Manitoba
Canada R3J 3S3
t. (204) 885-5590
f. (204) 832-7749

MacDon Inc.

10708 N. Pomona Avenue
Kansas City, Missouri
United States, 64153-1924
t. (816) 891-7313
f. (816) 891-7323

MacDon Australia Pty. Ltd.

A.C.N. 079 393 721
P.O. Box 243
Suite 3, 143 Main Street
Greensborough, Victoria
Australia 3088
t. 03 9432 9982
f. 03 9432 9972

CUSTOMERS

www.macdon.com

DEALERS

www.macdondealers.com

Trademarks of products are the marks of their
respective manufacturers and/or distributors.

Printed in Canada

Model D50 and D60 Harvest Header / CA20 Combine Adapter Pre-Delivery Checklist - N.A.

Perform these checks prior to delivery to your Customer. **Adjustments are normally not required as the machine is factory assembled and adjusted.** If adjustments are required, refer to the appropriate page number in this manual. The completed Checklist should be retained either by the Operator or the Dealer.



CAUTION: Carefully follow the instructions given. Be alert for safety related messages which bring your attention to hazards and unsafe practices.

Header Serial Number: _____ Adapter Serial Number: _____

✓	ITEM	PAGE
	Check for shipping damage or missing parts. Be sure all shipping dunnage is removed.	---
	Check for loose hardware. Tighten to required torque.	5 - 7
	Check tire pressure (Transport/Stabilizer Option).	61
	Check wheel bolt torque (Transport/Stabilizer Option).	61
	Check wobble box breather position.	61
	Check wobble box lube level.	61
	Check adapter gearbox box lube level.	62
	Check hydraulic reservoir lube level before and after run-up.	62
	Check sickle drive belt(s) tension.	62 - 63
	Check reel centered between header endsheets.	64
	Grease all bearings and drivelines.	71 - 74
	Check side draper tension.	65
	Check draper seal.	70
	Check header main float.	66 - 67
	Check reel tine to cutterbar clearance.	69
	Check skid shoes are evenly adjusted at a setting appropriate for first crop.	68
	Ensure feeder house variable speed is set to 'minimum'.	---
RUN-UP PROCEDURE		76
	Check hydraulic hose and wiring harness routing for clearance when raising or lowering header and reel.	---
	Check knife speed.	77
	Check lights are functional.	60
POST RUN-UP CHECK. STOP ENGINE.		78
	Check belt and chain drives for heated bearings.	17 & 62
	Check knife sections for discolouration caused by misaligned components.	78
	Check for hydraulic leaks.	---
	Check manual storage case contains all manuals.	75

Date Checked: _____

Checked by: _____