

Recommended Settings

Intended as a starting point. Fine-tune to crop and field conditions. Guidelines are subject to change without notice.

Crop Type	Stubble Height	Crop Condition	Divider Rods	Header Angle	Knife Speed	Reel Cam	Reel Speed %	Reel Fore-Aft	Skid Shoe Position	Stabilizer Wheels	Upper Cross Auger	Float	
Cereals	<102 mm (<4 in.)	Light	On	0-3	High	2	10-15	6 or 7	Up or Middle	Storage	Not required	311 N (70 lbf)	
		Normal			Medium		10						
		Heavy		4-7	3	5-10	4 or 5						
		Lodged											
	102-203 mm (4-8 in.)	Light	On	0-3	High	2	10-15	6 or 7	Middle or Down	Variable	Not required	311 N (70 lbf)	
		Normal			Medium		10		Down				
		Heavy		4-7	3	5-10	4 or 5						
		Lodged											
	>203 mm (>8 in.)	Light	On	0-3	High	2	10-15	6 or 7	Not applicable	Variable	Not required	667 N (150 lbf)	
		Normal			Medium		10						
		Heavy		4-7	3	5-10	4 or 5						
		Lodged											
Canola	102-203 mm (4-8 in.)	Light	On	8-10	Medium	2	5-10	6 or 7	Variable	Variable	Not required	311-445 N (70-100 lbf)	
		Normal			Low	1	10		Middle or Down				
		Heavy			2	5-10	3 or 4	Variable					
		Lodged						Middle or Down	Recommended				
	>203 mm (>8 in.)	Light	On	8-10	Medium	2	5-10	6 or 7	Not applicable	Variable	Not required	667 N (150 lbf)	
		Normal			Low	3	10						
		Heavy			3	5-10	3 or 4	Recommended					
		Lodged											
Flax	51-153 mm (2-6 in.)	Light	On	4-7	High	2	5-10	6 or 7	Middle or Down	Variable	Not required	311-445 N (70-100 lbf)	
		Normal		0-3			10						
		Heavy		4-7									
		Lodged		8-10									
Edible Beans	0 mm (0 in.) ground level	Light	Off	8-10	Medium	2	5-10	3 or 4	Up or Middle	Storage	Not required	445 N (100 lbf)	
		Normal				3							
		Heavy											
		Lodged											
Grass	0 mm (0 in.) ground level	Light	On	Variable	High	2	10	6 or 7	Up or Middle	Storage	Not required	311-445 N (70-100 lbf)	
		Normal					10-15						
		Heavy											
		Lodged											
Alfalfa	0 mm (0 in.) ground level	Light	On	Variable	High	3	10	6 or 7	Up or Middle	Storage	Not required	311-445 N (70-100 lbf)	
		Normal				2							
		Heavy				3							10-15
		Lodged											

Notes for using the Recommended Settings Chart

Header Angle

Header angle is the angle between the drapers and the ground and is adjustable to accommodate crop conditions and/or soil types. The angle is displayed as a value from 0 (shallow) to 10 (steep) on the windrower Harvest Performance Tracker (HPT).

Knife Speed

Knife speed is displayed on the windrower Harvest Performance Tracker (HPT) in strokes per minute (spm), and is adjustable with the controls in the windrower cab.

High – Upper part of range

Medium – Middle of range

Low – Lower part of range

Header Size	Recommended Double Knife Speed Range (spm)
4.6 m (15 ft.)	1500–1900
6.1 m (20 ft.)	1500–1900
7.6 m (25 ft.)	1400–1700
9.1 m (30 ft.)	1200–1600
10.7 m (35 ft.)	1200–1400
12.2 m (40 ft.)	1100–1400
13.7 m (45 ft.)	1100–1400

Reel Tine Pitch

Turn cam latch pin (A) to unlock cam disc.

Use wrench on bolt (B) until latch pin lines up with appropriate cam setting (C) between 1 and 4.

Increasing the cam setting increases the aggressiveness of the reel for picking up downed crop.

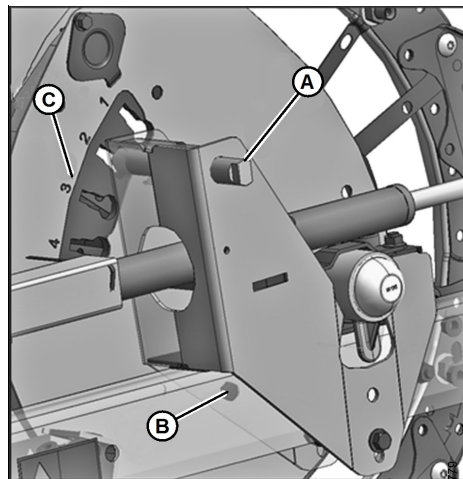

Reel Speed

Operate the reel at suggested percentage above ground speed. Reel speed is displayed on the HPT in mph, km/h, or rpm, and is adjustable with the controls in the windrower cab.

Reel Fore-Aft

The reel fore-aft position can be monitored from inside the windrower cab using the Harvest Performance Tracker (HPT) or checking the back edge of the reel cam disc (A) and decal (B) on the right reel support. Reel fore-aft adjustment is made using the ground speed lever (GSL).

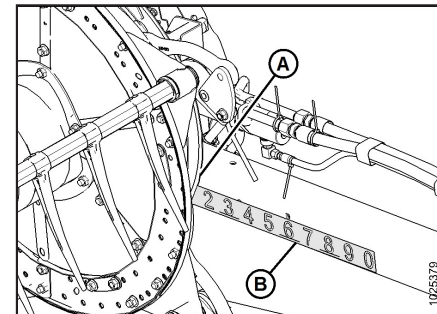

Skid Shoes

Remove lynch pin (A), disengage pin (B) from the frame, and move skid shoe (C) to desired position. There are three hole positions: top, middle, and bottom.

For a lower cutting level, raise the skid shoe by installing pin (B) in the bottom hole.

For a higher cutting level, lower the skid shoe by installing pin (B) in the top hole.

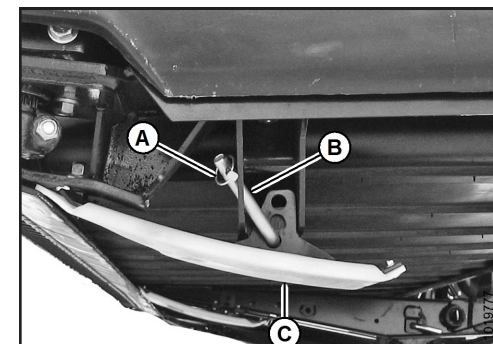

Float

The recommended float setting is 334–378 N (75–85 lbf). Rocky conditions or cutting at faster ground speeds may require that float be set heavier to prevent excessive header movement. Refer to windrower operator's manual for procedures.

Draper Speed

Draper speed is set based on ground speed, crop mass, volume, and windrow formation. Faster ground speed or heavier crop requires increased draper speed to convey material. Slower ground speed or lighter crop requires slower draper speed to ensure even crop flow. Refer to windrower operator's manual.