

QUICK REFERENCE CARD

NEW HOLLAND CR 920/940/960 COMBINES

Combine Initial Settings

- Adjust front drum height to small grains position as per combine operators manual.
- Ensure feeder house output shaft speed is 575 rpm.



CR FEEDER HOUSE

- Fully retract header tilt cylinder and lower header until it slightly contacts the ground. At this point adjust feeder faceplate angle to align pendulum with rear face of adapter (if applicable).

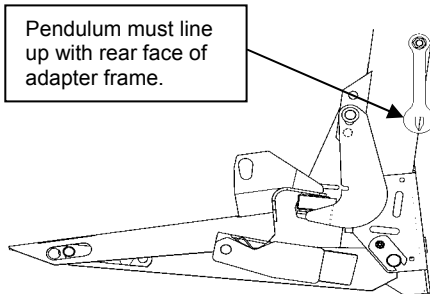

- Remove all feeder house dust shields, enclosure panels, etc.

873 Adapter Initial Settings

- Place adapter leg pin in proper hole for your header model as follows:
 - 963/972/973/974/84C headers in hole (B), (factory set) with dust shields and hole (A) with dust shields removed.
- Place adapter down stop pin in proper hole for your header model as follows:
 - 973/974/84C headers in hole (2), (factory set).
 - 963/972 headers in hole (3).

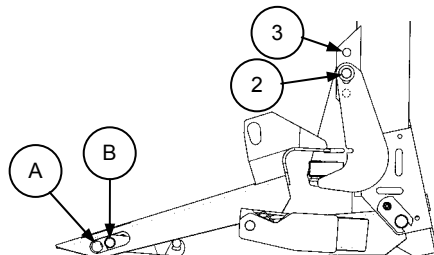

- If mounting adapter to a header, ensure down stop pads are orientated properly (both sides).
 - 963/972/973 header with dust shields removed and 973 with dust shields on, orientation is correct as shipped (D).
 - 963/972 with dust shields on, orient pads to position (F).
 - 974/84C headers, orient pads to position (E).

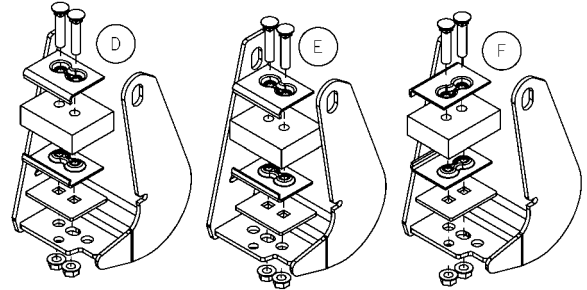

- For 972/973/974/84C - Install skid plate on adapter feed pan so dim. D = 4-11/32" (110 mm) in **Hole B** (dust shields installed). For 963 - Slide transition plate forward until feed pan bolts hit front of slot
- For 972/973/974/84C - Install skid plate on adapter feed pan so dim. D = 3-1/2" (90 mm) in **Hole A** (dust shields removed). For 963 - Slide transition plate rearward until feed pan bolts hit rear of slot.

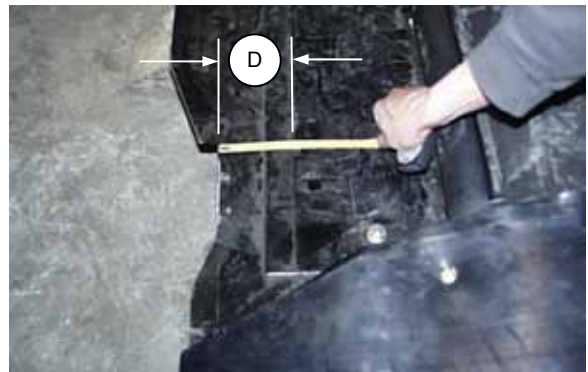

- Refer to 873 Operator's Manual for adjustment details.
- Adjust RTD position to achieve 1" to 2" dimension. **Note:** To achieve this feed chain on combine may need to be fully extended.

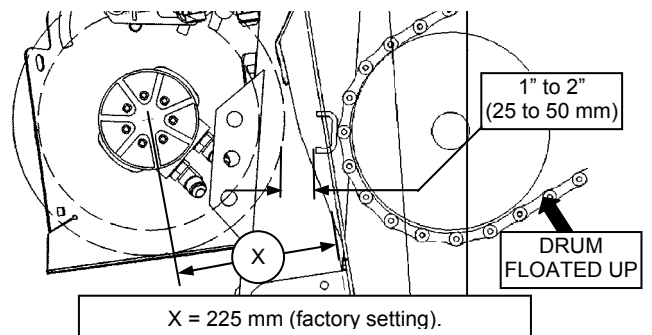

- Set the center link between the header and adapter to 19-1/4" (490 mm) length (pin to pin).
- Set the float to specs given on pages 3 & 4.
- Set the draper speed flow control so number "4" is at the 12 o'clock position.

QUICK REFERENCE CARD

NEW HOLLAND CR 920/940/960 COMBINES

Header Initial Settings

- See page 4 for 963 Header.
- For 973/974/84C Model Headers: Set the center delivery opening to **37.6"** (955 mm).

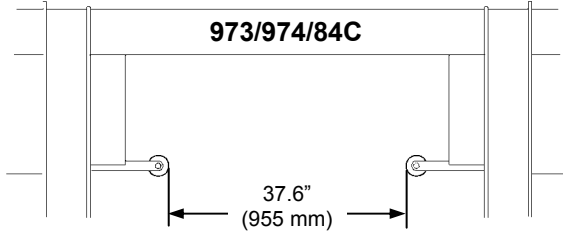

- Position the decks so there is equal overlap of adapter feed draper each side.
- Align the vertical edge of the rear deflectors on the feed pan just inside the edge of the feeder house opening to ensure smooth crop flow.
- Re-check skid plate clearance (set during 873 initial settings) with adapter inserted in header. (see appropriate dimensions below) Refer 873 Operator's Manual for further details.

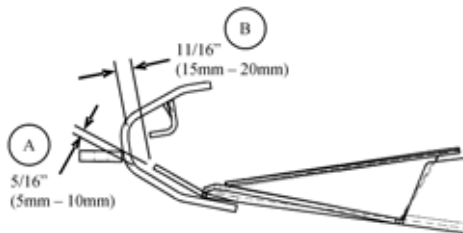

PAN CLEARANCE TO CUTTERBAR
972/973/974 HEADER

NOTE: A 5-10mm gap at (A) is equivalent to a 15-20mm gap at (B).

- Gauge wheels are intended to help float the header when cutting off the ground. For such applications set gauge wheels in the Short – Tall setting depending on cut height. **Note:** When cutting on the ground place gauge wheels in the storage position.

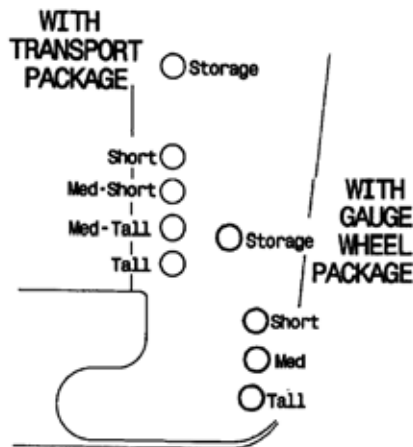

Pickup Reel Initial Settings

- See page 4 for 963 Header.
- Install bolt (C) through the cam arm with head inboard and torque to 120 ft. lbs. (162 N·m.)

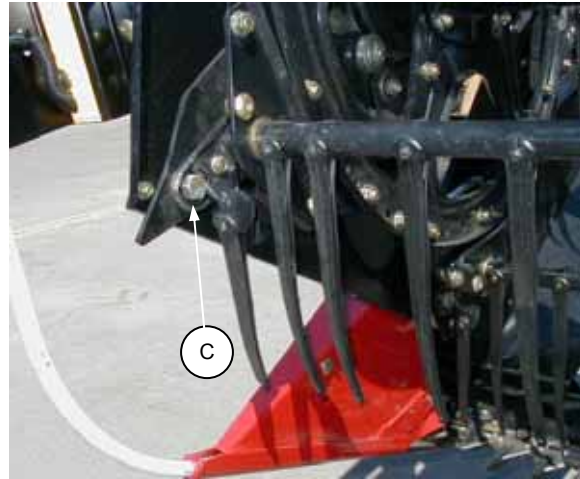

- Adjust the finger pitch to position **5**.

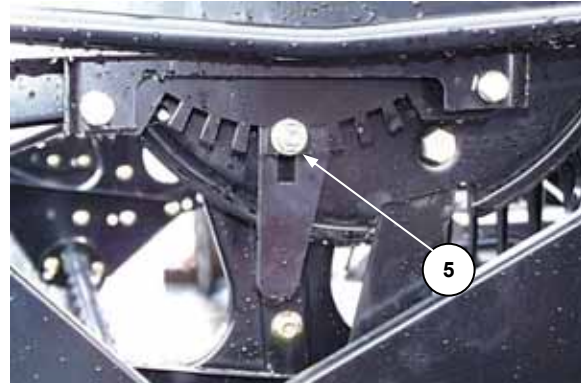

- Set the fore/aft position to between **4** and **5** on the gauge decal at left reel support arms.



- Reel finger to sickle guard minimum clearance with reel fully lowered is **5/8"** (15mm), **measured at both ends of the cutterbar for 973 headers. For 974/84C headers, flex to full frown when checking clearance.**
- Recommended reel speed is 10% above ground speed.

QUICK REFERENCE CARD

NEW HOLLAND CR 920/940/960 COMBINES

973/2052 & 974/2062/84C Initial Set-up

<u>Average Cereal Crops</u>	<u>Rice</u>		<u>Soybeans</u>	
	<u>Normal Cutting</u>	<u>Tough Cutting</u>	<u>Dry Conditions</u>	<u>Wet Conditions</u>
Sickle- Check daily that guards are aligned. Clearance from hold down to sickle 0.020" (0.5mm)	-	-	-	-
2100 reel Fore/Aft- 4 or 5 on decal Finger Pitch Adjustment- Slot 5 Reel Clearance- 5/8" (15mm) for 973/2052 headers and at hinge points for 974/2062/84C headers in full frown. Refer to 973/974 Operator's Manual. Speed- +10 % ground speed.	5 - - -	7 - - -	6 Slot 7 ½" (13mm) -	6 Slot 7 ½" (13mm) -
Draper Speed- Dial position "4". Draper opening- 37.6" (955 mm) Reduce opening if side drapers are back feeding.	- -	Position 3 or 4 50.6" (1285 mm)	- -	- -
Guard Angle- center link 19-¼" (490 mm) length (pin to pin). Poly Skids- Optional on 973/2052	- Yes	- Yes	- Yes	Center link fully retracted. Yes
Gauge Wheels (if equipped)- Most cereals require "medium" stubble height setting Note: Gauge wheels should be in storage position for on the ground cutting applications.	Not Applicable	Not Applicable	Storage	Storage
Float- Adjust float to achieve 0" gap at downstop pad. (Refer to 873 Operator's Manual)	½" gap	½" gap	½" gap	½" gap

QUICK REFERENCE CARD

NEW HOLLAND CR 920/940/960 COMBINES

963/2042 Initial Set-up.	Field Peas		Soybeans		
	Average Cereal Crops	Dry Conditions	Wet Condition	Dry Conditions	Wet Condition
Sickle -Check daily that guards are aligned. Clearance from hold down to sickle 0.020" (0.5mm)	-	-	-	-	-
2000B Reel Fore/ Aft -5 th hole/frt. Cam Arm -Y Range Slot - P Finger Pitch - L or M Reel Clearance - 2" (50 mm) Speed - +10% of ground speed	2 nd from front Y Q M 2" (50mm) -	2 nd from front. Y P J 2" (50mm) -	2 nd from front X P M 2" (50mm) -	2 nd from front. X P M 2" (50mm) -	
Draper Speed - Dial position "4".	-	-	-	-	-
Draper opening - 33.9" (860 mm)	-	-	-	-	-
Guard Angle - 1.0" (25mm) of threads showing on center link. Poly Skids - None	- Yes	- Yes	- Yes	Center link fully retracted. Yes	
Gauge Wheels (if equipped) - Most cereals require "position 2" stubble height setting. Note: Gauge wheels should be in storage position for on the ground cutting applications.	Storage	Storage	Storage	Storage	
Float - Adjust float to achieve 0" gap at downstop pad. (Refer to 873 Operator's Manual)	½" gap	½" gap	½" gap	½" gap	

