

**30', 36' & 39'**  
**Model 972/973/974**  
**HARVEST HEADER**

**SLOW SPEED**  
**TRANSPORT OPTION**

---

**OPERATOR'S MANUAL**

---

Inside Front Cover  
(blank)

# TRANSPORT OPTION

Some 30', 36' & 39' foot headers are equipped with the transport option which allows pivoting the gauge wheels 90° to allow towing the header sideways.

This supplement provides instructions for Set-Up, Converting to and from Transport Position, Transport Safety and recommended Maintenance.

## TABLE OF CONTENTS

Set-up Instructions .....	2 - 10
Electrical Schematic.....	11
Converting from Field Position to Transport .....	12 - 15
Transport Safety.....	16
Converting from Transport to Field Position .....	17 - 21
Raising Wheels to Storage Position.....	22
Poly Wearplate Modification for 973 & 974 Headers .....	22
Maintenance / Service.....	23, 24

## TRANSPORT OPTION

### SET-UP INSTRUCTIONS

**NOTE:** For ease of assembly, if header is still in shipping position install wheel supports and springs before lowering header to field position. Take care not to damage components when header is lowered. These instructions assume the header is already lowered to field position.

1. Use a lifting vehicle to raise rear of header, or attach header to windrower or combine and raise header fully.



**DANGER:** To avoid bodily injury or death from unexpected start-up or fall of raised header, stop engine, remove key and engage header lift cylinder stops before going under header for any reason. If using a lifting vehicle, be sure header is secure before proceeding.

2. Identify right and left wheel supports. Left wheel support has dual spindle.
3. Ensure plastic bushings (A) are installed (2 per support). Position wheel assembly in header leg and install tube (B) from right side of header leg through wheel support. Secure with two 5/8 x 1-1/4" carriage bolts (heads outboard) and flange nuts.

**IMPORTANT:** If wheels are required for transport only and will not be used in field mode to assist header floatation or to stabilize sway, installation of springs is not required. Leaving the springs off makes putting the wheels into and out of transport position easier, however springs are required if used for floatation in field mode. See "Raising Wheels to Storage Position", page 22.

4. Attach one spring per side:

L/H Wheel Support: Engage spring hook in anchor (C) at wheel support, then attach front end of spring to header leg with pin (D). Secure with cotter pins.

**NOTE:** Tube (B) is designed to be a press-fit into leg. Use a hammer or the hardware to fully engage tube into leg (with flange on tube flush to leg).

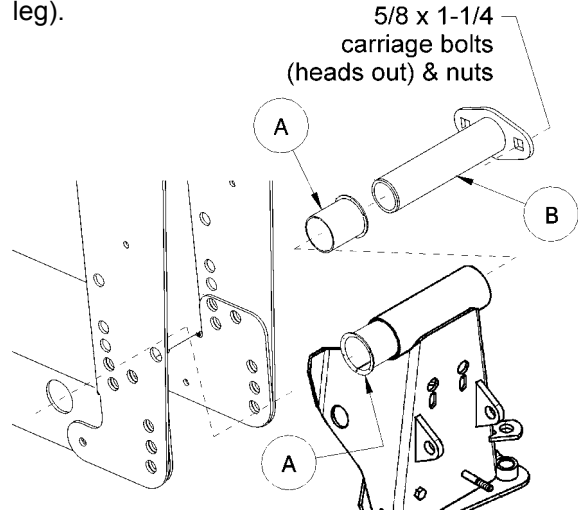

INSTALL WHEEL SUPPORTS



ATTACH SPRING

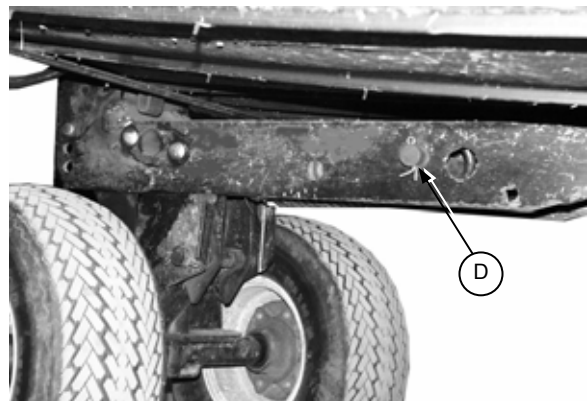

## TRANSPORT OPTION

### 5. R/H Wheel Support:

- a. Engage spring hook in anchor at wheel support same as L/H side shown in Step 4. Attach front end of spring and trans-axle assembly to header R/H leg as follows:

**NOTE:** The trans-axle can be installed on inboard or outboard side of leg for 972 or 973 headers, **but must be outboard on 974 Headers**. This determines the side of the leg where the trans-axle wheel will be placed in storage. For headers with R/H decks that can be split for end delivery, choose the side that places the working wheel away from the windrow delivery opening.

**IMPORTANT:** For 973/974 headers, spacer (E) for transaxle is not used. Install 33mm ID x 57mm OD flat washer provided in kit instead. For both inboard (973) and outboard (973/974) installations, position washer on outside of leg with one cotter pin inside leg and one outside.

#### For installation outboard of header leg - 972:

- b. Knuckle (A) must be tight against face of header leg when trans-axle is mounted on outboard side of header leg.



VIEW FROM REAR OF HEADER –  
OUTBOARD SIDE – OUTBOARD INSTALLATION

- c. Install cotter pin (B) through **second** hole from end of pivot shaft and through spacer to hold knuckle against other face of header leg. Store second cotter pin (C) in outer hole of pivot shaft. **NOTE:** Assembly of knuckle away from face of leg will result in excessive “toe-in” of R/H wheel located underneath cutterbar.

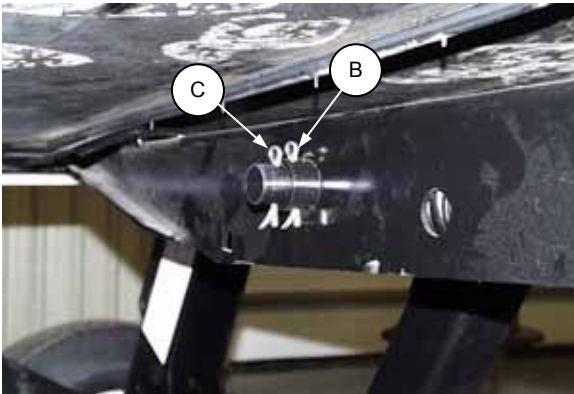

VIEW FROM REAR OF HEADER – INBOARD SIDE  
OUTBOARD INSTALLATION – 972 ONLY

#### For installation inboard of header leg – 972:

- d. Space knuckle away from leg as at (D) when installing on inboard side of header leg.



VIEW FROM REAR OF HEADER – INBOARD SIDE  
- INBOARD INSTALLATION – 972 ONLY

- e. Install spacer (E) against inside face of header leg to maintain knuckle spacing away from other face of header leg. Install cotter pin (G).

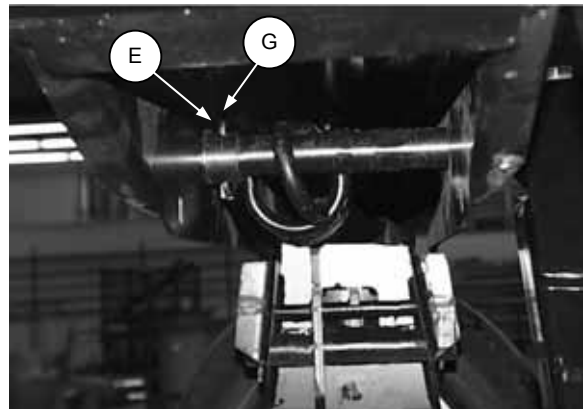

VIEW FROM FRONT OF HEADER – INSIDE LEG  
- INBOARD INSTALLATION – 972 ONLY

- f. Install cotter pin (F) through last hole in pivot shaft on outboard side of leg.

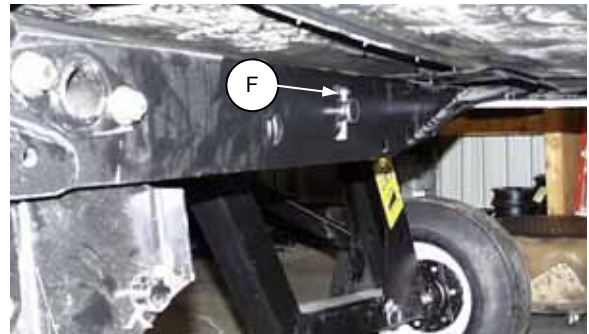

VIEW FROM REAR OF HEADER –  
OUTBOARD SIDE – INBOARD INSTALLATION – 972 ONLY

## TRANSPORT OPTION

### SET-UP INSTRUCTIONS

6. Install trans-axle storage latch at right header leg. Install on same side of leg as trans-axle. See Step 5. Engage top leg of torsion spring on edge of header leg as shown.



TRANS-AXLE INBOARD

TRANS-AXLE OUTBOARD

### STEP 6: INSTALL STORAGE LATCH

**NOTE:** Step 7 is for 972 and 973 Headers only – Not required for 974 Header.

7. Install anchor (G) for diagonal brace under cutter bar.

**For trans-axle positioned inboard of R/H leg:** Install anchor at 14<sup>th</sup> guard bolt inboard of center of R/H header leg.  
**For trans-axle positioned outboard of R/H leg:** Install anchor at 10<sup>th</sup> guard bolt inboard of center of R/H header leg.

**NOTE:** For applications where the sickle guards are installed above the cutterbar, install anchor spacer (H) and special hardware as shown. For applications where guards are below cutterbar, use 7/16 x 2-1/4 hex head bolt (head down) and locknut. Spacer (H) and special hardware are not used with guards below cutterbar.

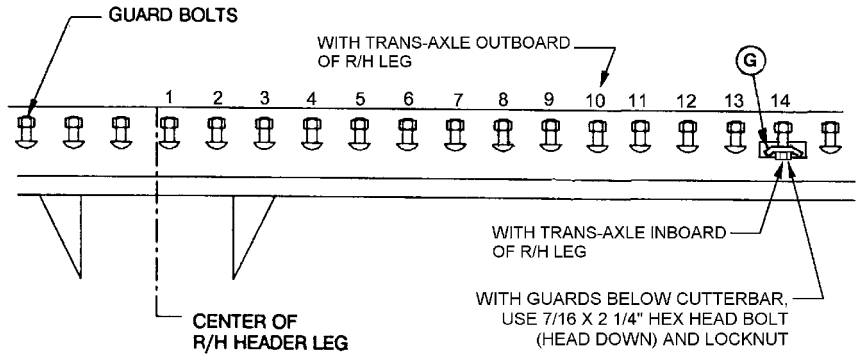

### INSTALL BRACE ANCHOR AT CUTTERBAR

DIRECTION OF TRAVEL

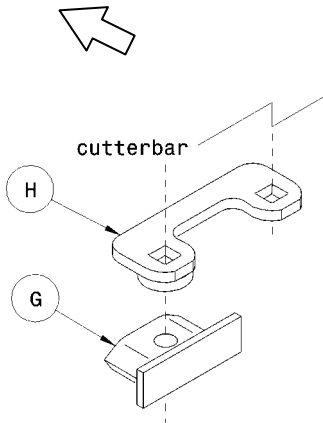

**BOLT POSITION 14**  
 TRANS-AXLE INBOARD OF  
 HEADER LEG. GUARDS  
 ABOVE CUTTERBAR.

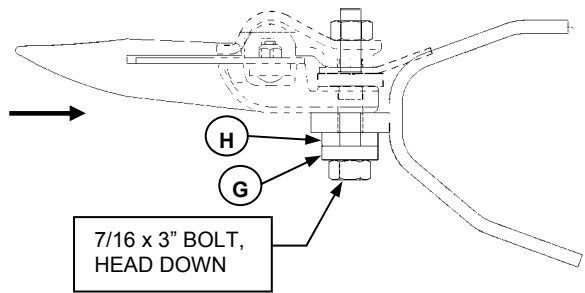

**BOLT POSITION 10**  
 TRANS-AXLE OUTBOARD  
 OF HEADER LEG. GUARDS  
 ABOVE CUTTERBAR.

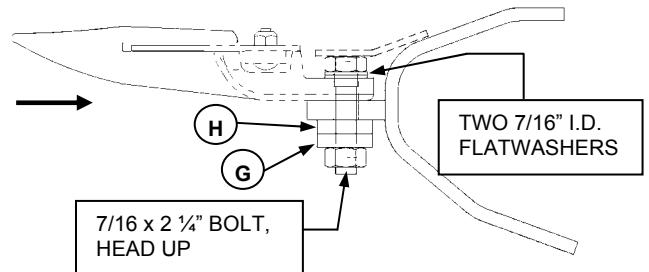

## TRANSPORT OPTION

### SET-UP INSTRUCTIONS

8. Attach the four gauge wheels to hubs. Torque wheel bolts to 80 to 90 ft. lbs. (110 to 120 N·m). Use the two longer wheel bolts (9/16 NF x 1 1/2") to bolt handle to trans-axle wheel.



STEP 8:  
HANDLE BOLTS TO TRANS-AXLE WHEEL

9. At L/H support, install upper pin (A) in desired stubble height position and secure with split ring. When header is lowered, spring-loaded bracket will engage upper pin as shown below.

Push down on handle (B) and lock under welded bolt head to raise pin (C) to allow wheel to pivot. Pivot wheel to field position. Release handle (B) from under bolt head to lower pin (C) and lock in field position.



L/H WHEEL SUPPORT: FIELD POSITION

10. At R/H support, install upper pin (D) in desired stubble height position and secure with split ring. When header is lowered, spring-loaded bracket will engage upper pin.

Push down on handle (F) and lock under welded bolt head to raise pin (G) to allow wheel to pivot. Pivot wheel to desired field position. Release handle (F) from under bolt head to lower pin (G) and lock in field position.

**NOTE:** Wheel can be positioned on either side of support, depending on delivery opening position. (See Step 5.)

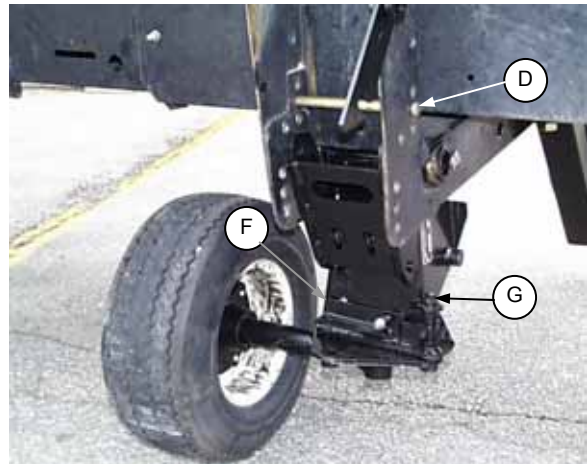

R/H WHEEL SUPPORT: FIELD POSITION

**NOTE:** Install the two decals provided on the inboard face of left and right frame legs as shown below. The decals indicate proper pin position for storage, different levels of stubble height, and transport.



DECAL PLACEMENT  
LEFT FRAME LEG



DECAL PLACEMENT  
RIGHT FRAME LEG

## TRANSPORT OPTION

### SET-UP INSTRUCTIONS

11. Roll the trans-axle to the rear of the header. Lift and engage head of hitch pin (C) in notch of storage latch.
12. Lower header onto gauge wheels.
13. Check tire pressure. Inflate to 100 psi (690 kPa).
14. Place hitch in storage on back tube: At left endsheet, install storage support (D) with 1/2 x 1 short neck carriage bolt and flange lock nut.  
**NOTE:** Orient support (D) for best clearance of tow pole to header hoses, etc. in storage.

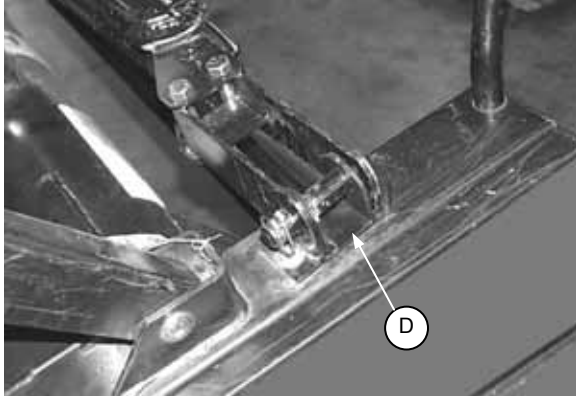

STEP 14: HITCH STORAGE AT ENDSHEET

#### **For 30' & 36' 972/973 headers:**

At inboard end, attach support (E) to header left leg with two 1/2 x 1 carriage bolts and flange nuts.

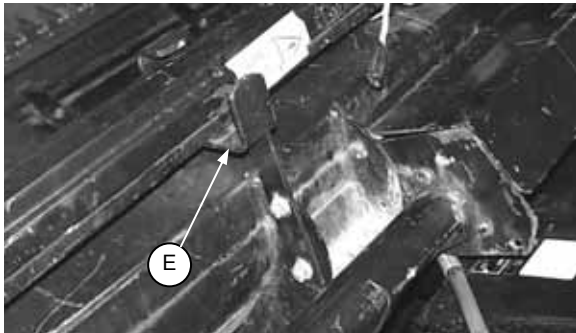

STEP 14: HITCH STORAGE AT LEG  
(30' & 36' 972/973 HEADERS)

#### **For 30' 974 headers:**

At L/H flex joint, attach bracket (G) to the bell crank prior to installation of support (E) as shown, using 1/2 x 1 inch carriage bolts and flange nuts.

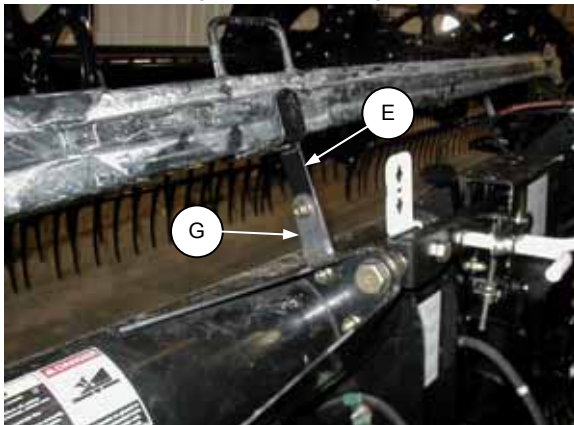

STEP 14: HITCH STORAGE AT FLEX JOINT  
(30' 974 HEADERS)

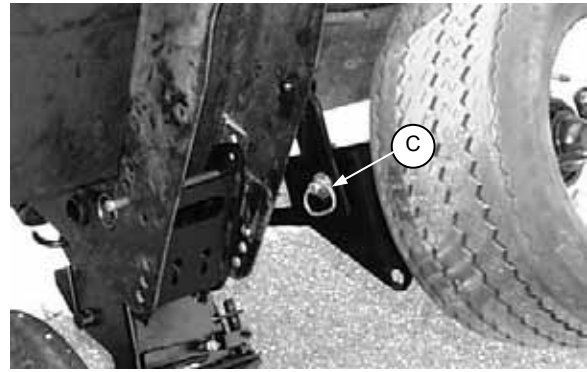

STEP 11:  
PLACE R/H WHEEL IN STORAGE

#### **For 39' 973 headers:**

At inboard end, attach support (E) to bracket welded to header back tube using two 1/2 x 1 carriage bolts and flange nuts.

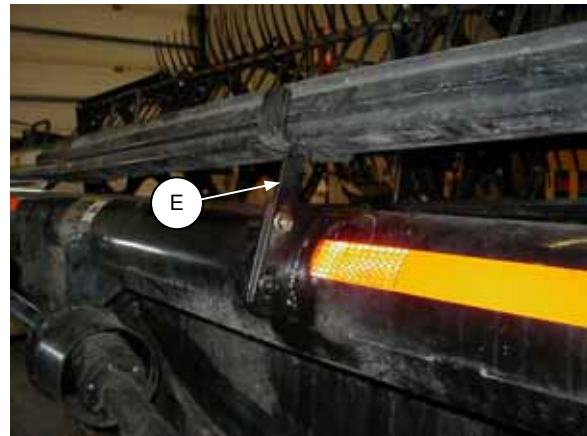

STEP 14: HITCH STORAGE ON FRAME  
(39' 973 HEADERS)

#### **For 36' 974 headers:**

Attach support (E) directly to the L/H flex joint using 1/2 x 1 carriage bolt and flange nut as shown

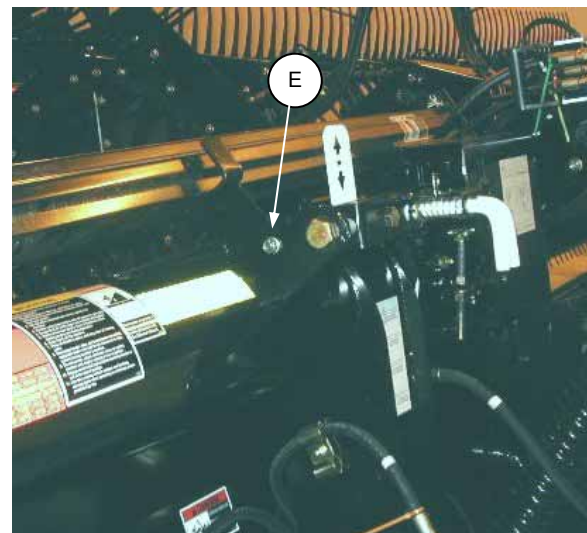

STEP 14: HITCH STORAGE AT FLEX JOINT  
(36' 974 HEADERS)



## TRANSPORT OPTION

### SET-UP INSTRUCTIONS

14. (continued):

Lay hitch clevis over storage support (D) and secure with hitch pin and lynch pin.

Rest hitch in support (E). Secure hitch chain and electrical harness at bracket (F) as shown. Use the locking device on hitch chain to secure the hook.

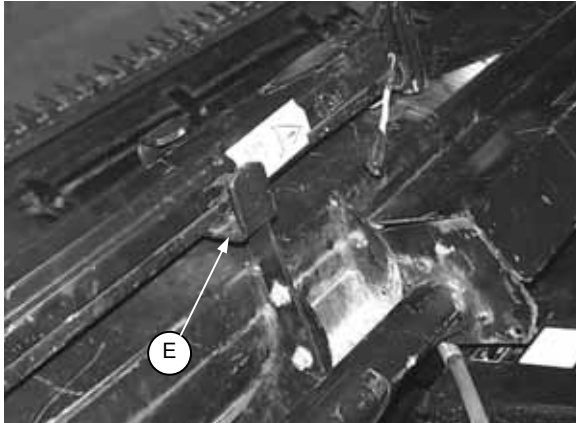

STEP 14: HITCH STORAGE AT LEG  
(30' & 36' 972/973 SHOWN)

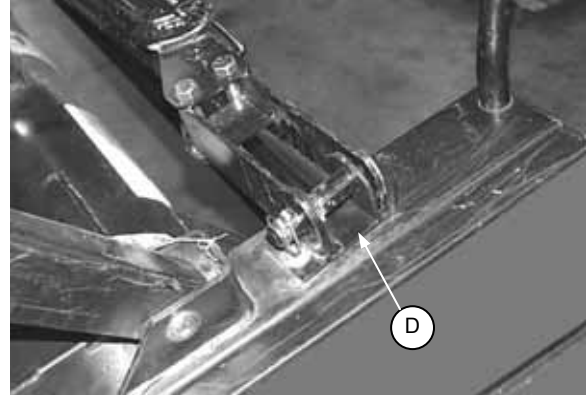

STEP 14: HITCH STORAGE AT ENDSHEET

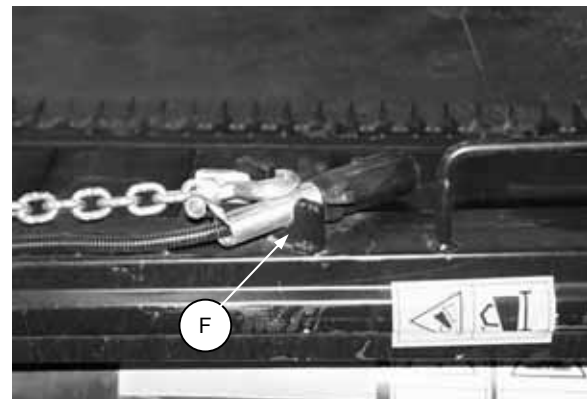

STEP 14: CHAIN & HARNESS STORAGE

## TRANSPORT OPTION

### SET-UP INSTRUCTIONS

15. **972 Headers:** Store diagonal brace on back tube: Install diagonal brace storage bracket (G) at right end of channel under header back tube using one 3/8 x 1 carriage bolt and flange lock nut.

**NOTE:** Use lower hole in bracket (G) to mount on 36' 972 Headers. For 30' 972 Headers, use top hole to lower bracket sufficiently to allow installation of diagonal brace. (Crop lifter storage bracket (H) is not present on all headers.)

Place diagonal brace (K) in bracket as shown below and insert J-bar (J) through slots in bracket (G) and diagonal brace. Secure J-bar with lynch pin as shown. *For 972 headers with 973 riveted style cutterbar poly skids, use longer J-bar provided in poly kit.*

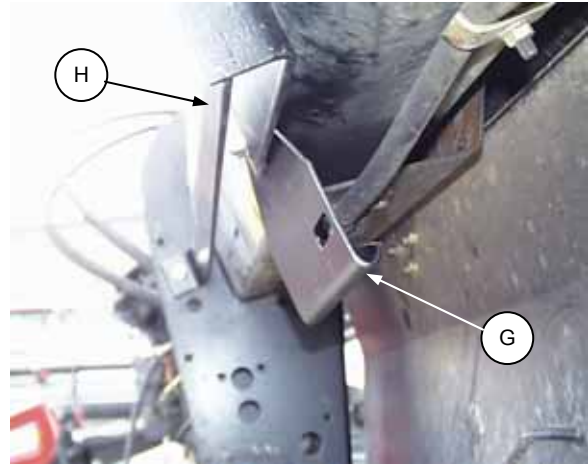

STEP 15:  
STORAGE BRACKET FOR BRACE - 972

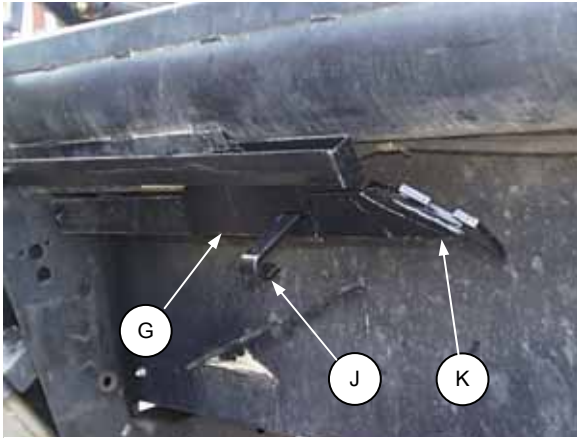

STEP 15:  
DIAGONAL BRACE & J-BAR STORAGE - 972

**973 Headers:** Store diagonal brace (K) in slots provided in right frame leg. Insert J-bar (J) in slot in diagonal brace and secure with lynch pin. *For 973 Headers with riveted style cutterbar poly skids, use the longer J-bar provided in poly kit.*

**974 Headers:** Store diagonal brace (K) in slots provided in right frame leg. Install clevis pin and split ring at (L).

← END VIEW



STEP 15:  
DIAGONAL BRACE & J-BAR STORAGE - 972

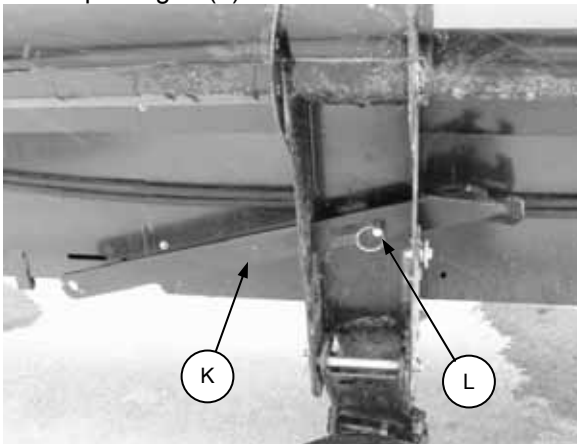

STEP 15: DIAGONAL BRACE STORAGE - 974

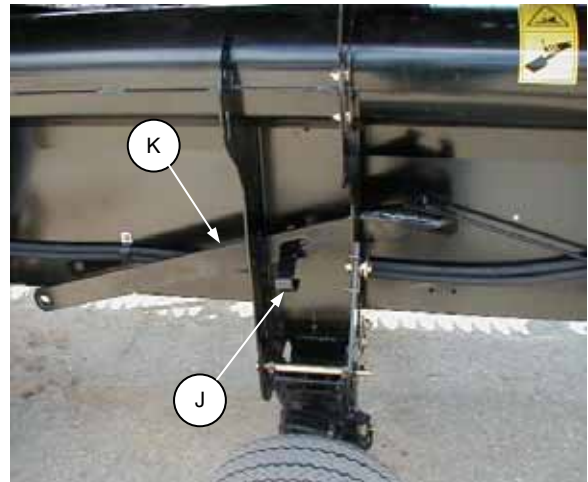

STEP 15: DIAGONAL BRACE STORAGE - 973

## TRANSPORT OPTION

### SET-UP INSTRUCTIONS

16. Route header wiring harness as follows:

- Route the harness from the outboard L/H header leg up and through space between the back sheet and the header back tube. Route the harness with the lines along front of tube and back into the inboard L/H header leg at (Z). Attach ground wire (M) with 1/4 x 1/2 inch hex head bolt and flange nut. Continue routing harness through back tube to R/H end.

**NOTE:** To aid in pulling the harness through the tube to the R/H end, a plastic coated wire has been factory installed. Secure harness end to wire end and pull wire through tube from R/H end panel.

**NOTE:** For headers with hydraulic reel fore-aft, cable tie harness to existing hydraulic lines running along the front of back tube. For headers without hydraulic reel fore-aft, use clamps and self tapping screws to secure harness along front of back tube.

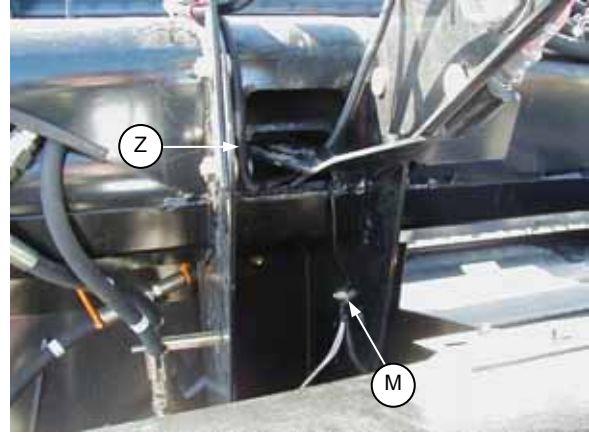

STEP 16: ROUTE HEADER HARNESS

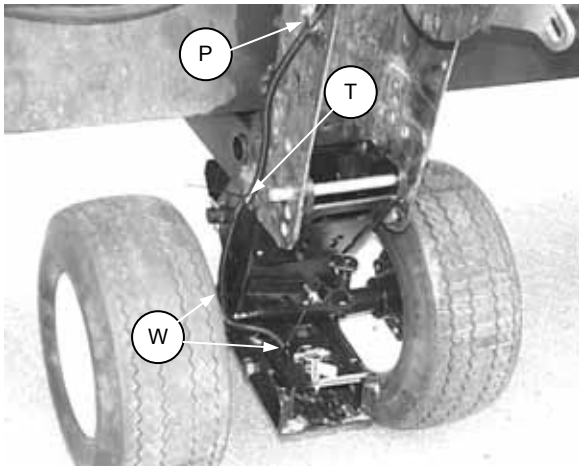

- Secure harness at the outboard L/H header leg with harness clip at (P). Place other clips for best appearance. Secure with cable tie at (T), leaving 24" (610 mm) of harness from bottom of header leg to connector. After installing hitch for the first time, swing wheel assembly to simulate 90° turns left and right. Ensure adequate harness slack and install cable ties at (W).

17. At R/H end sheet, install lamp module and support as follows: For Single Sickle Headers, install at (N) with the hardware that secures the sickle storage tube. For Double Sickle Headers, install at clamp (V).

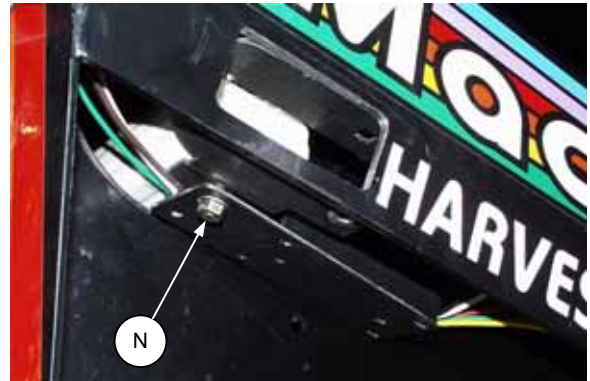

STEP 17: INSTALL LAMP MODULE – Single Sickle

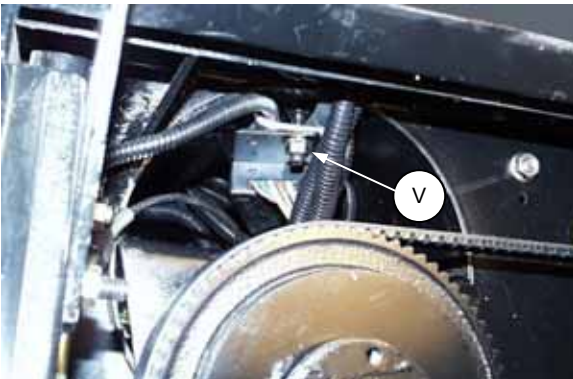

STEP 17: INSTALL LAMP MODULE – Double Sickle

18. Connect header harness and end sheet harness to lamp module. Route end sheet harness to top of end sheet through hole at reel support arm anchor (S).

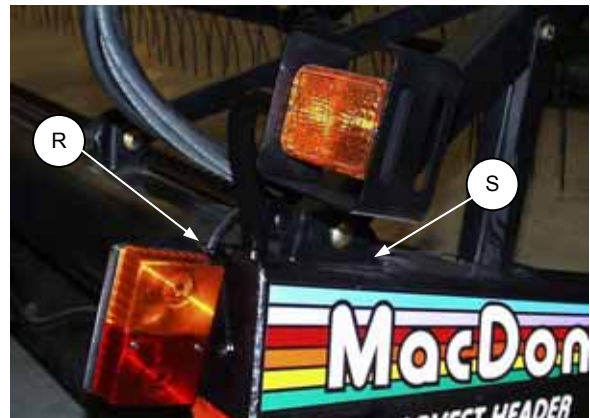

STEP 19: INSTALL LIGHTS AT END SHEET

19. Install lights at R/H end sheet using the hardware that secures the pivoting amber lights. Secure harness with plastic tie at (R).

## TRANSPORT OPTION

### SET-UP INSTRUCTIONS

20. Install lights at R/H reel support arm using 1/2 x 1 inch carriage bolts and flange nuts as shown.

**NOTE:** For headers with floating divider option, a different light mounting bracket is required. See instructions packaged with dividers.

21. Install harness guard as shown at (A).

22. For 972 Headers: Install harness guard holder (G) on reel arm as shown. Secure holder with 5/8 x 1 inch hex head bolt and lock nut.

23. Route harness up inside reel support arm and over bolt (D). Pass harness through guard to lights and make the connections. Secure harness with plastic tie at (C) (see inset, top photo).

**NOTE:** Wire colors do not match up when connecting harness to lights. Refer to wiring schematic on page 11.

24. For 972 single sickle drive headers: Attach Slow Moving Vehicle sign to R/H endsheet with spacer (between sign and endsheet), 3/8 x 1-3/4 carriage bolt and flange nut as shown below left.

For 972 double sickle drive headers: If not present, drill a 0.406" hole in R/H reel support arm located 7-1/2" (190 mm) rearward of reel lift cylinder pin (F), and 3/8" (10 mm) above center-line of reel lift cylinder pin (F). Attach sign to reel arm with spacer (between sign and arm), 3/8 x 1-3/4 carriage bolt and flange nut as shown below center at (E).

For 973 & 974 headers: Attach Slow Moving Vehicle sign to R/H reel support arm with spacer (between sign and arm), 3/8 x 1-3/4 carriage bolt and flange nut as shown below right. For these headers, harness guard holder (G) is not used. Position harness guard above SMV hardware to secure back end.

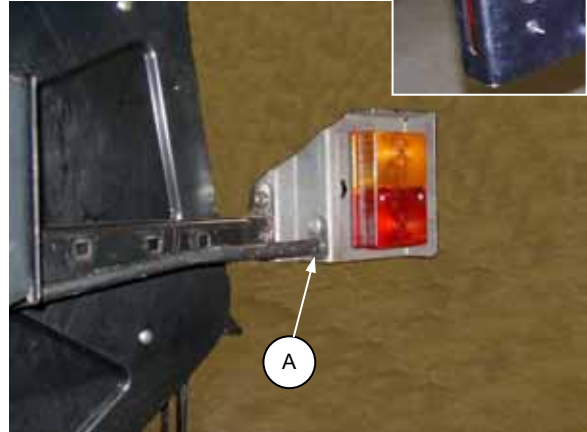
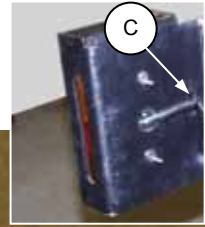

INSTALL LIGHTS & HARNESS GUARD AT R/H REEL ARM

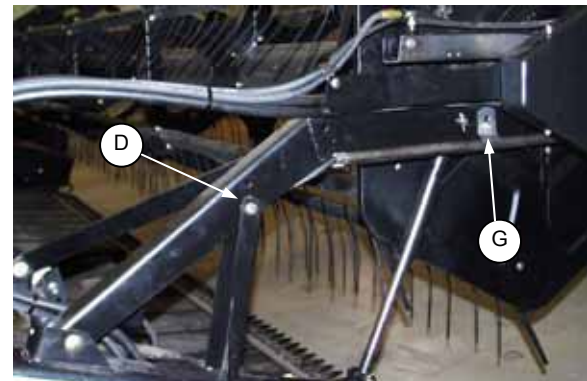

INSTALL GUARD HOLDER - 972



972 SINGLE SICKLE DRIVE

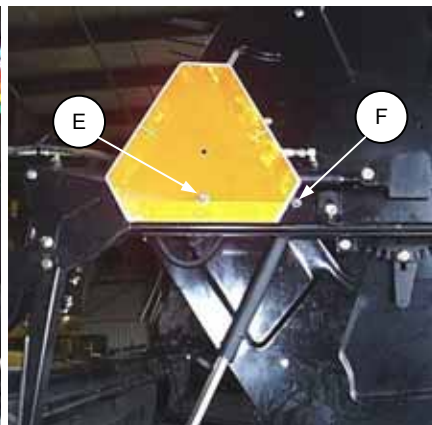

972 DOUBLE SICKLE DRIVE  
INSTALL SMV SIGN



973 / 974 HEADERS

# TRANSPORT OPTION

## ELECTRICAL SCHEMATIC

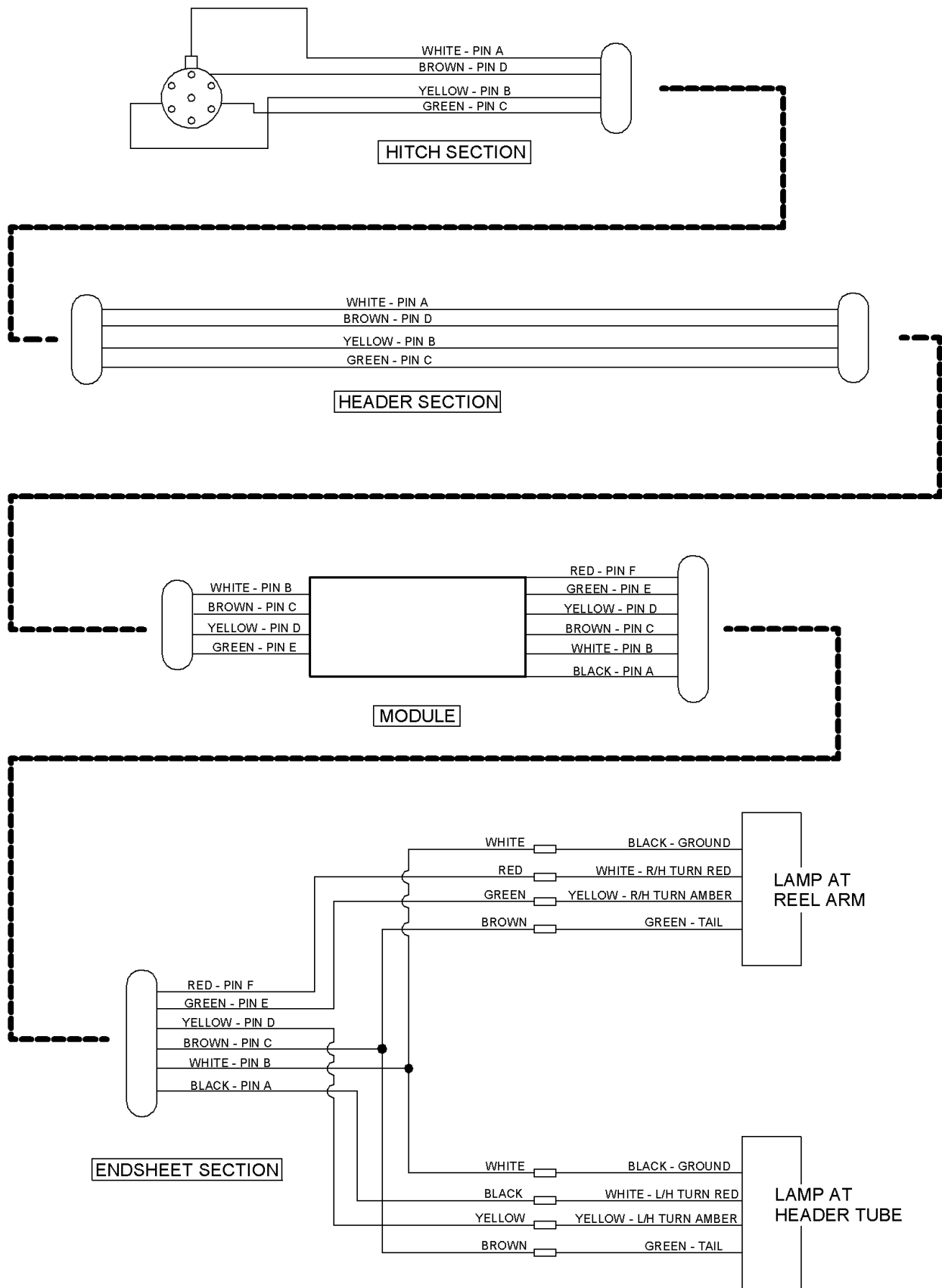

## TRANSPORT OPTION

### CONVERTING FROM FIELD POSITION TO TRANSPORT



**WARNING:** To avoid injury or caused by machine tip-over, move reel fore-aft position to stabilize the load on the two rear wheels in transport. Do not move reel while machine is in transport.

1. Move reel fully back on support arms unless combine adapter is installed in header\*. See "Reel Position - Fore & Aft" in Header Operator's Manual for adjustment details. For manual fore-aft: To avoid binding, move reel two positions at a time, alternating sides so reel moves back evenly. Lower reel. **NOTE:** To prevent damage to reel support arms, do not transport with reel props engaged.

\* **IMPORTANT:** If header is being transported with combine adapter installed:

- With pick up reel – Move reel to a mid-range fore-aft position.
- With bat reel – Move reel further forward.

**Always check stability of load before transporting. The rear wheels should be carrying approximately the same weight.**

2. Fully retract center link between header and adapter.
3. Raise header fully.



**DANGER:** To avoid bodily injury or death from unexpected start-up or fall of raised header, stop engine, remove key and engage header lift cylinder stops before going under header for any reason.

4. Engage float lockout on combine adapter. See Adapter Operator's Manual.

**NOTE:** Steps 5 to 9 are for 974 Flex Header only.

5. Move all four wing float lockout pins to "lockout" position (E). To move pins from "float engaged" position (F) to position (E), see "974 Flex Header: Wing Float Set-Up and Pre-Delivery Check" in Unloading and Assembly section of Header Operator's Manual.

**NOTE:** Steps 6 to 9 are intended to increase ground clearance in transport. If you desire more than 300 mm (12") clearance under the combine adapter when transporting, proceed with steps 6 to 9. Otherwise, go to step 10.

6. Place two 250 mm (10") blocks (A) under center section of cutterbar as shown below.
7. With outer L-pins (E) engaged (in) and inner L-pins (F) disengaged (out), lower header onto blocks.
8. At left and right bellcrank top links, install clevis pin (B) into the transport position (through the bell crank top link) as shown and secure with hairpin. This locks the header in the "frown" position. **NOTE:** On first use, it will be necessary to push tab at hole (B).
9. Raise header fully, engage lift cylinder stops and proceed to step 10.

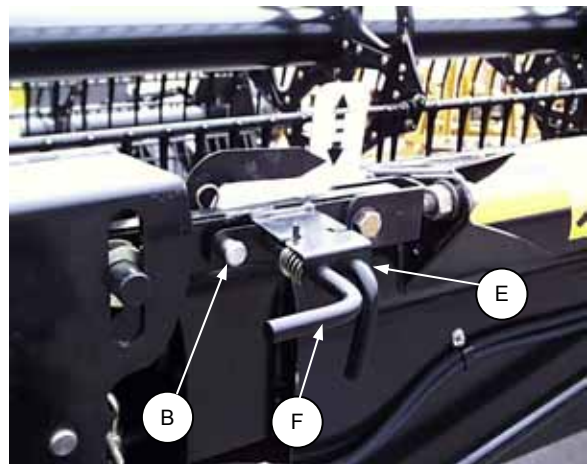

- LOCK OUT WING FLOAT – 974 HEADER
- LOCK HEADER INTO FROWN POSITION FOR INCREASED GROUND CLEARANCE IN TRANSPORT

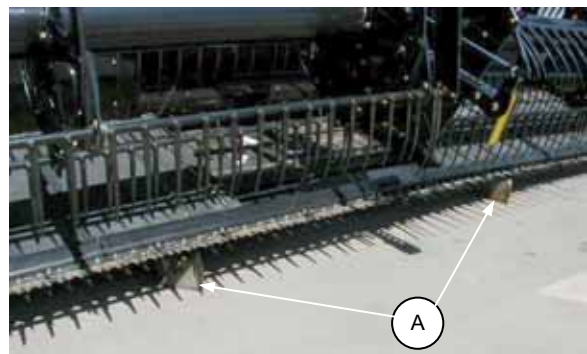

974 HEADER - BLOCK CENTER SECTION OF CUTTERBAR

## TRANSPORT OPTION

At R/H end:

10. Disengage header lift cylinder stops and slowly lower header until wheels are on the ground. Continue lowering header until upper pins are loose. Remove upper pins (C) at left and right wheels. Pins (C) will be installed in transport position in step 17.
11. Raise header fully.



**DANGER:** To avoid bodily injury or death from unexpected start-up or fall of raised header, stop engine, remove key and engage header lift cylinder stops before going under header for any reason.

12. Lift the R/H cutterbar-side wheel to release storage latch at (A). Roll the wheel and trans-axle under cutterbar to transport position.
13. Remove hitch pin from strut channel. Pivot strut channel upwards and engage strut hook into slot on back edge of cutterbar. Install hitch pin in transport position (B). Secure with split ring.

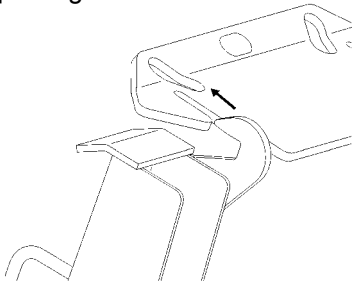

STEP 13:

ENGAGE STRUT HOOK ON CUTTERBAR

**NOTE:** For 973 and 974 Headers with poly wearplates on cutterbar, it will be necessary to notch poly in two places. See page 22.

14. Remove diagonal brace from storage position on header.

**For 972 and 973 Headers:** Engage head of brace on cutterbar anchor and rotate brace clockwise to engage head behind the guard trash bar.

**For 974 Header:** Install brace onto lug welded to rear of cutterbar and secure with  $\frac{3}{4}$  x 1-3/16 clevis pin and split ring.



STEP 14: ENGAGE BRACE ON LUG –  
974 HEADER

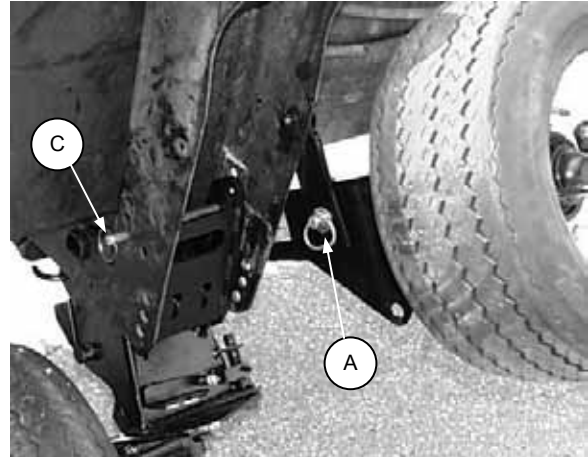

STEP 12:

RELEASE R/H WHEEL FROM STORAGE

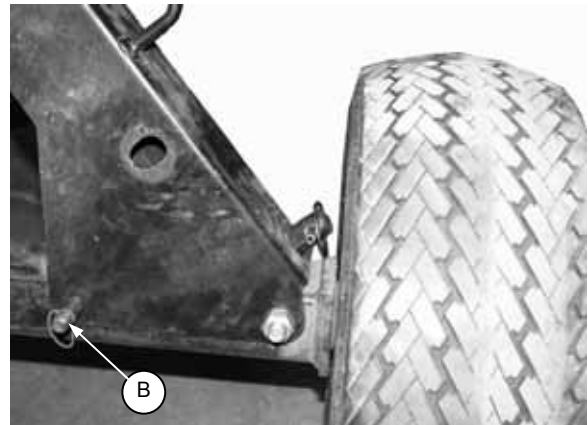

STEP 13: INSTALL PIN IN STRUT



STEP 14: ENGAGE BRACE ON ANCHOR –  
972 & 973 HEADERS

## TRANSPORT OPTION

### CONVERTING FROM FIELD POSITION TO TRANSPORT (continued)

15. Engage other end of diagonal brace on pin at strut. Secure with lynch pin.



STEP 15: SECURE BRACE TO STRUT

16. **972 & 973 Headers only:** Hook the J-bar on back edge of cutterbar and through head of diagonal brace. Secure with lynch pin. *For 972 & 973 Headers with 973 riveted style cutterbar poly skids, use the longer J-bar provided in poly kit.*



STEP 16: INSTALL J-BAR –  
972 & 973 HEADERS

17. Install pins removed in step 10 in transport position (A), engaging the hole in spring loaded bracket as shown in lower right photo. Secure with split ring.

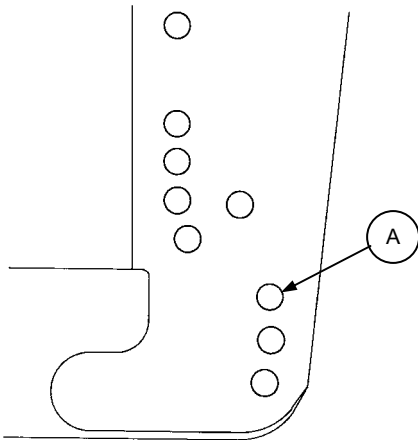

18. Raise header fully and engage lift cylinder stops.
19. At R/H rear wheel, push down on handle (F) and lock under welded bolt head to raise pin (G) to allow wheel to pivot. Pivot wheel to transport position. Release handle (F) from under bolt head to lower pin (G) and lock in transport position.

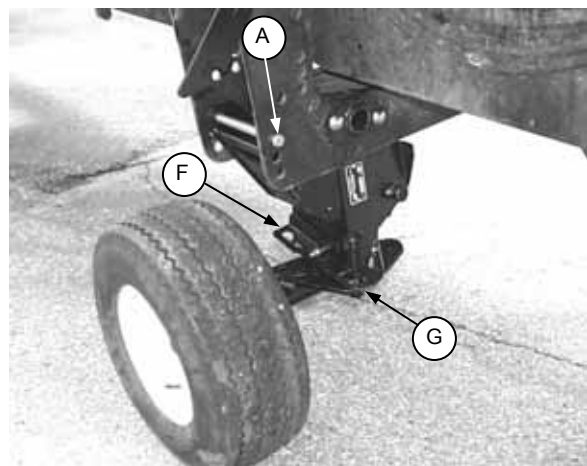

STEPS 17 - 19:  
POSITION R/H REAR WHEEL



## TRANSPORT OPTION

### CONVERTING FROM FIELD POSITION TO TRANSPORT (continued)

At L/H end:

20. Install hitch in socket of dual wheel spindle, engaging hitch end-pin in channel slots.
21. Lower the top channel and secure with lynch pin (A). Push down on handle (B) and lock under welded bolt head to raise pin (C) to allow wheel to pivot. Leave handle in locked position, as the dual wheel assembly must be free to pivot in transport.
22. Connect header wiring harness to hitch harness at (D).
23. Swing the hitch pole around to the left end.
24. If combine adapter is to remain with the header, ensure float lock-outs are engaged.
25. Disengage header lift cylinder stops and slowly lower header until wheels are on the ground. Block the tires to prevent header rolling.
26. Detach header from power unit. See Windrower Tractor or Combine Adapter Operator's Manual. Be sure reel is fully down and all hydraulic lines are properly disconnected and stored.



**WARNING:** For headers with hydraulic reel fore-aft, never connect the fore-aft couplers to each other. This would complete the circuit and allow the reel to creep forward in transport, resulting in instability.



STEP 20:  
INSTALL HITCH IN SPINDLE SOCKET

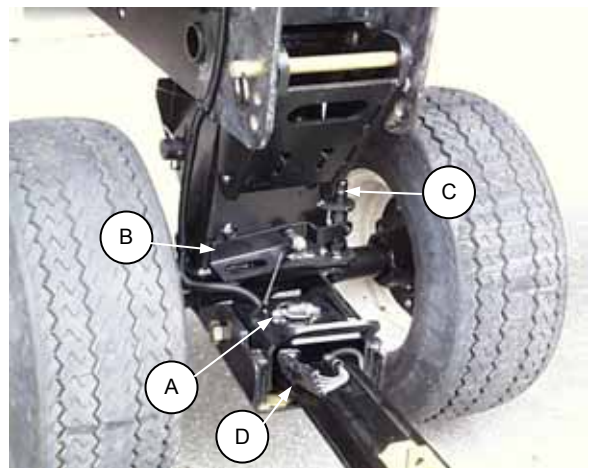

STEPS 21 - 22:  
L/H DUAL WHEELS – TRANSPORT POSITION



STEP 23:  
SWING HITCH TO TRANSPORT POSITION

## TRANSPORT OPTION

### ATTACHING TO TOWING VEHICLE



**CAUTION:** To avoid bodily injury and/or machine damage caused by loss of control:

1. To ensure adequate braking performance and control, do not tow with a vehicle weighing less than 5000 lbs. (2300 kg).
2. To increase header stability in transport, ensure that reel is down and fully back on support arms. For headers with hydraulic reel fore-aft, never connect the fore-aft couplers to each other. This would complete the circuit and allow the reel to creep forward in transport, resulting in instability.
3. Check that all pins are properly secured in transport position at wheel supports, hitch and cutterbar support.
4. Check tire condition and pressure prior to transporting.
5. Connect hitch to towing vehicle with a proper hitch pin with a spring locking pin or other suitable fastener.
6. Attach hitch chain to towing vehicle. Adjust chain length to remove all slack except what is needed for turns.
7. Connect header wiring harness 7-pole plug to mating receptacle on towing vehicle. (The 7-pole receptacle is available from your dealer parts department.)
8. Ensure lights are functioning properly, and clean the slow moving vehicle emblem and other reflectors.

### TOWING THE HEADER



**CAUTION:** THIS IS INTENDED AS A LOW SPEED TRANSPORT. To avoid bodily injury and or machine damage caused by loss of control:

1. Do not exceed 20 mph (30 km/h). Reduce transport speed for slippery or rough conditions.
2. Turn corners only at very low speeds [5 mph (8 km/h) or less]. While cornering, header stability is reduced as front wheel moves to the left.
3. Obey all highway traffic regulations in your area when transporting on public roads. Use flashing amber lights unless prohibited by law.

## TRANSPORT OPTION

### CONVERTING FROM TRANSPORT TO FIELD POSITION

1. Block the tires to prevent header rolling.
2. Attach header to power unit.  
See Windrower Tractor or Combine Adapter Operator Manual.
3. Raise header fully.



**DANGER:** To avoid bodily injury or death from unexpected start-up or fall of raised header, stop engine, remove key and engage header lift cylinder stops before going under header for any reason.

4. Swing the hitch pole around to the back of the header. Detach header wiring harness from hitch harness at 4-way connector (A). Wrap header harness around lynch pin locking bracket (C) once hitch is removed.
5. Remove lynch pin (B), raise the top channel and remove hitch from socket of dual wheel spindle.
6. At L/H support, install upper pin (D) in desired stubble height position and secure with split ring. When header is lowered, spring-loaded bracket will engage upper pin as shown.

Release handle (E) from under bolt head to lower pin (F) and lock in field position.

**NOTE:** If cutting low to the ground and no gauge wheel contact is desired, wheels can be raised to storage position. See page 22.

At R/H end:

7. **972 & 973 Headers:** Detach J-bar (J) which locks diagonal brace to cutterbar.  
**974 Header:** Remove split ring and clevis pin (K) securing diagonal brace to lug at rear of cutterbar.



STEP 7: REMOVE CLEVIS PIN FROM LUG – 974 HEADER



STEP 5: DETACH HITCH

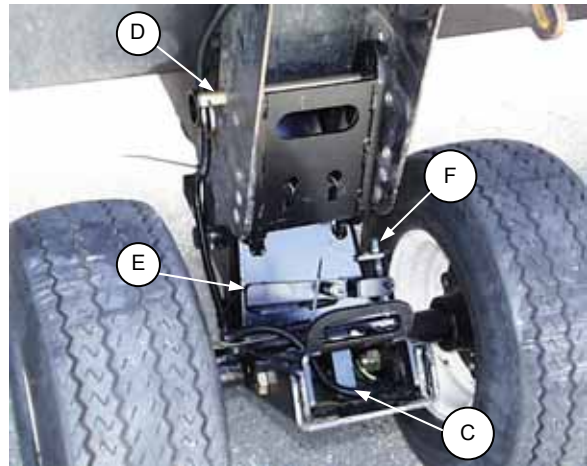

STEP 6:  
L/H DUAL WHEELS – FIELD POSITION

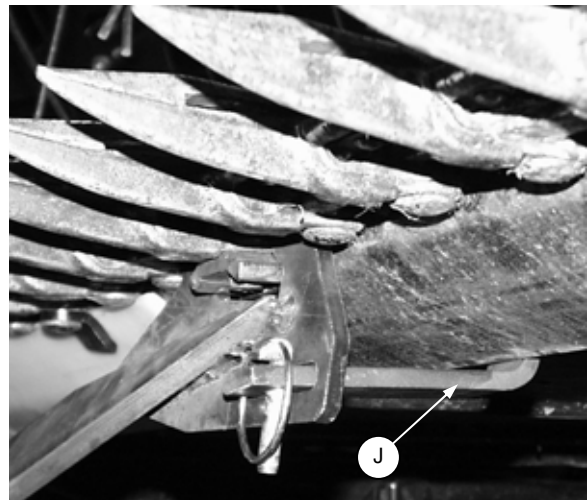

STEP 7: DETACH J-BAR – 972 & 973 HEADER

## TRANSPORT OPTION

### CONVERTING FROM TRANSPORT TO FIELD POSITION (continued)

8. Detach diagonal brace from strut channel at (A) and remove brace head from cutterbar. Remove pin (B) from transport position.

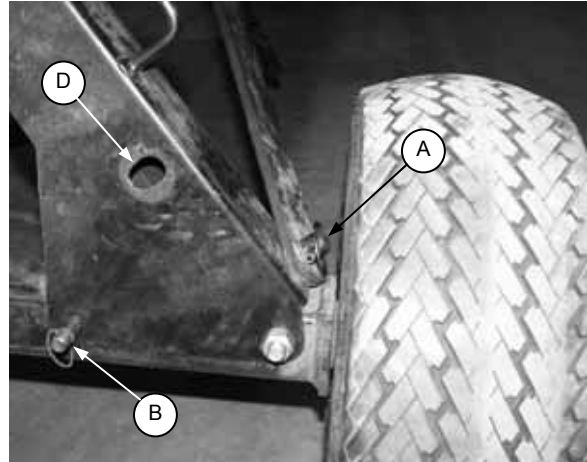

STEP 8: DETACH BRACE FROM STRUT & REMOVE PIN

9. Disengage strut hook from cutterbar and pivot strut channel down to collapsed position on the trans-axle. Install pin (B) in storage position (through hole D in above photo) and secure with split ring.

**NOTE:** Install pin so head is on correct side for storage of trans-axle wheel. See Step 11.

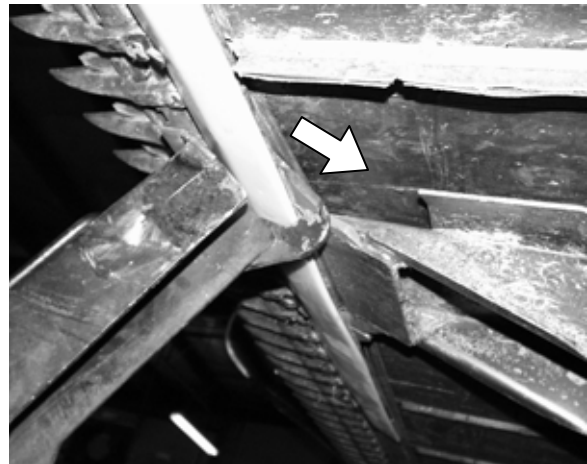

STEP 9: DETACH STRUT HOOK

10. At R/H support, install upper pin (D) in desired stubble height position and secure with split ring. When header is lowered, spring-loaded bracket will engage upper pin.

Push down on handle (F) and lock under welded bolt head to raise pin (G) to allow wheel to pivot. Pivot wheel to desired field position. Release handle (F) from under bolt head to lower pin (G) and lock in field position.

**NOTE:** Wheel can be positioned on either side of support, depending on delivery opening position.

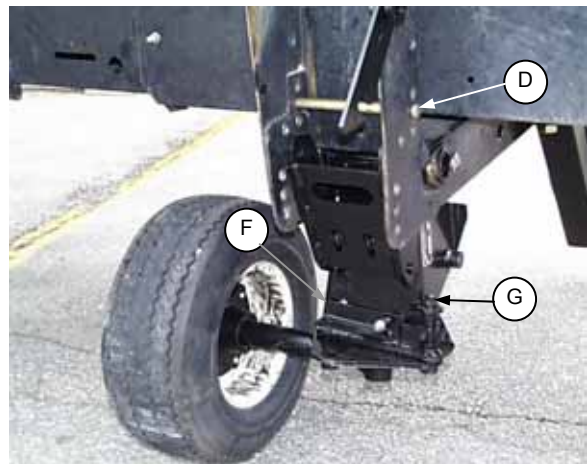

STEP 10: R/H FIELD WHEEL

## TRANSPORT OPTION

### CONVERTING FROM TRANSPORT TO FIELD POSITION (continued)

- Roll the trans-axle to the rear of the header. Lift and engage head of hitch pin (C) in notch of storage latch.
- NOTE:** Trans-axle can be positioned on either side of leg, depending on delivery opening position.
- Lower header to cutting height and move reel to desired operating position. For manual fore-aft: To avoid binding, move reel two positions at a time, alternating sides so reel moves back evenly.



STEP 11:  
TRANS-AXLE WHEEL STORAGE

- Place hitch in storage on back tube: At left endsheet, lay hitch clevis over storage support (D) and secure with hitch pin and lynch pin. At inboard end, rest hitch in support (E). Secure hitch chain and electrical harness at bracket (F) as shown. Use the locking device on hitch chain to secure the hook.

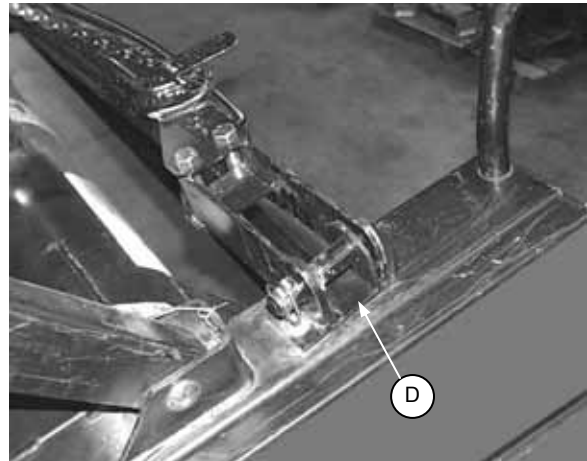

STEP 13: HITCH STORAGE AT ENDSHEET

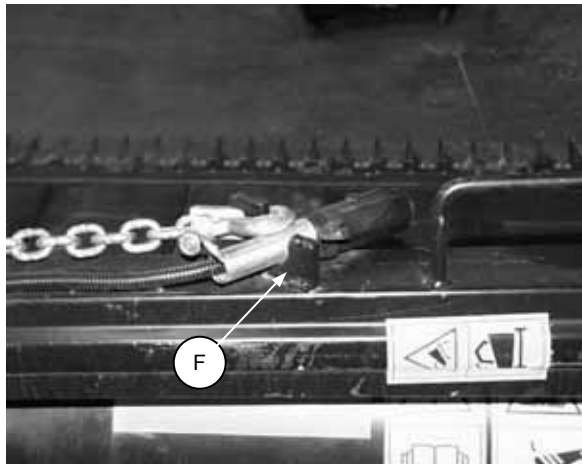

STEP 13: CHAIN & HARNESS STORAGE

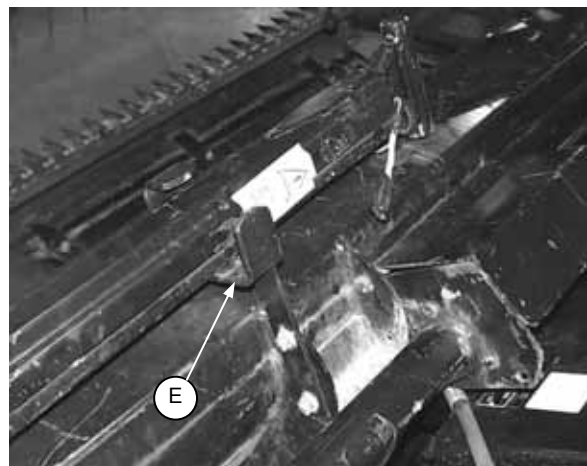

STEP 13: HITCH STORAGE AT LEG

## TRANSPORT OPTION

### CONVERTING FROM TRANSPORT TO FIELD POSITION (continued)

14. **972 Headers:** Place diagonal brace (K) in bracket (G) at right end of channel under header back tube as shown below and insert J-bar (J) through slots in bracket (G) and diagonal brace. Secure J-bar with lynch pin as shown.

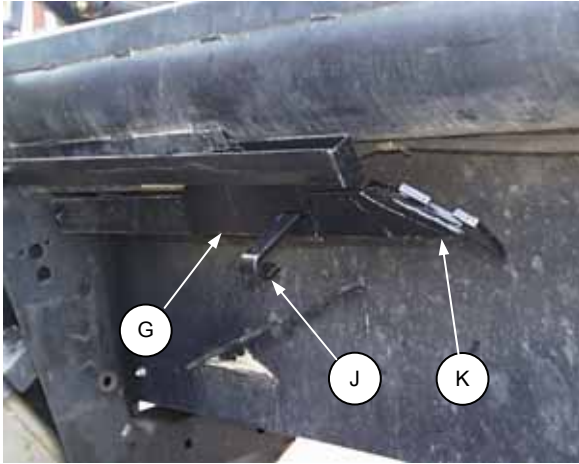

STEP 14:  
DIAGONAL BRACE & J-BAR STORAGE - 972

- 973 Headers:** Store diagonal brace (K) in slots provided in right frame leg. Insert J-bar (J) in slot in diagonal brace and secure with lynch pin.

- 974 Headers:** Store diagonal brace (K) in slots provided in right frame leg. Install clevis pin and split ring at (L).

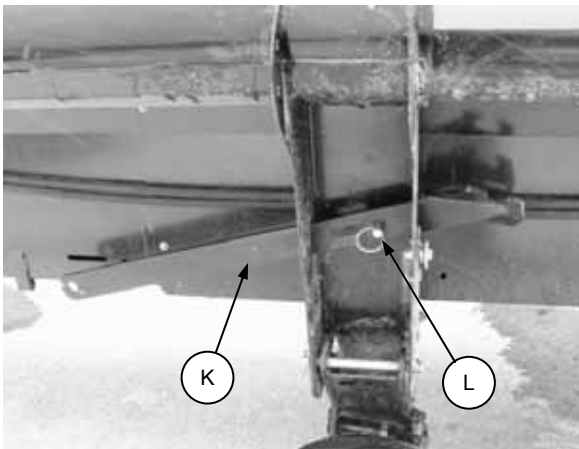

STEP 14: DIAGONAL BRACE STORAGE – 974

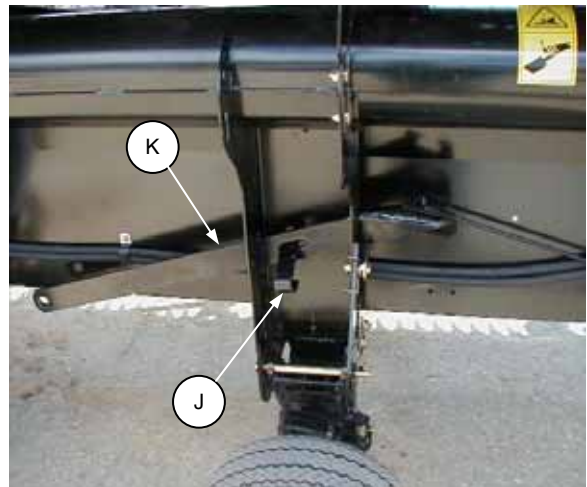

STEP 14: DIAGONAL BRACE STORAGE – 973

## TRANSPORT OPTION

### CONVERTING FROM TRANSPORT TO FIELD POSITION (continued)

15. Raise header fully.



**DANGER:** To avoid bodily injury or death from unexpected start-up or fall of raised header, stop engine, remove key and engage header lift cylinder stops before going under header for any reason.

16. Disengage float lockout on combine adapter and extend center link to desired operating position. See Adapter Operator's Manual.

**NOTE:** Remaining steps are for 974 Flex Header only.

**NOTE:** If pins (B) were installed through bellcrank top link to increase ground clearance in transport, complete steps 17 to 20 to move pins to storage position as follows:

17. Place two 250 mm (10") blocks (A) under center section of cutterbar as shown.

18. Lower header onto blocks.

19. At left and right bellcrank top links, retract clevis pin (B) to the storage position as shown and secure with hairpin.

20. Raise header and engage lift cylinder stops.

21. Move all four wing float lockout pins to "float engaged" position (F).

22. Disengage lift cylinder stops and lower header.

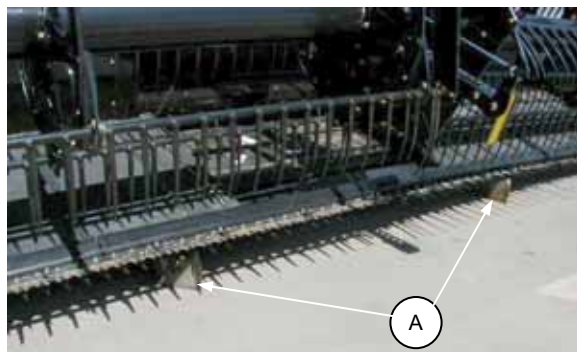

974 HEADER - BLOCK CENTER SECTION OF CUTTERBAR

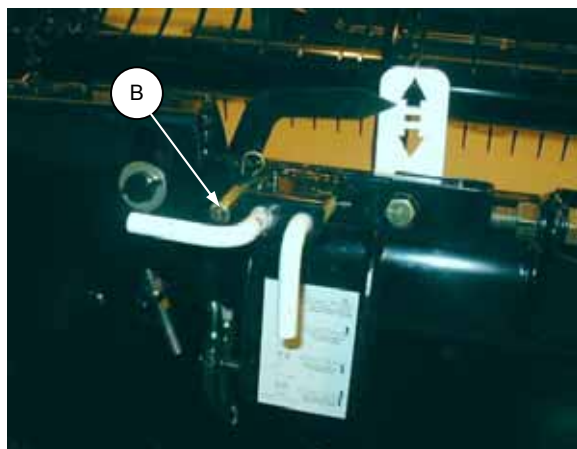

FLEX HEADER – MOVE "FROWN LOCK" PINS TO STORAGE POSITION

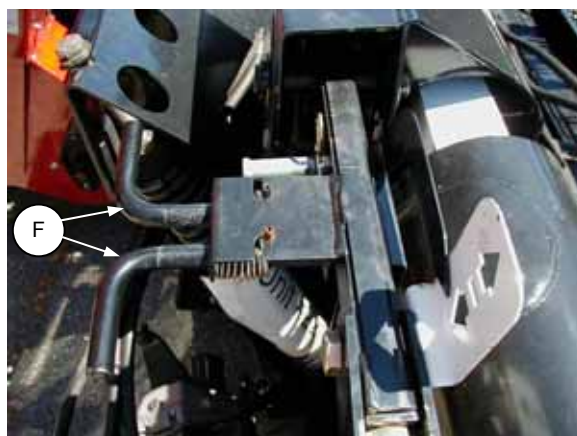

974 HEADER –  
DISENGAGE WING FLOAT LOCKOUT

## TRANSPORT OPTION

### RAISING WHEELS TO STORAGE POSITION

If cutting low to the ground and no gauge wheel contact is desired, wheels can be raised to storage position, as follows:

- Raise header fully.



**DANGER:** To avoid bodily injury or death from unexpected start-up or fall of raised header, stop engine, remove key and engage header lift cylinder stops before going under header for any reason.

- If springs were removed from wheels, simply raise wheel support by hand and install pin in storage position, both sides. If springs are installed, proceed as follows:
- Place 10" (250 mm) blocks under L/H and R/H gauge wheels as shown.
- Lower header until cutterbar touches ground.
- Place pins (D) into storage location to lock wheels in raised position.
- Raise header and remove blocks.

**NOTE:** When converting to transport position when wheels are in storage as above, it will be necessary to block wheels as shown to allow removal of pin (D) (if springs are installed).

### POLY WEARPLATE MODIFICATION FOR 973 & 974 HEADERS

For 973 and 974 Headers with poly wearplates on cutterbar, it will be necessary to notch poly in two places.

There are two types of cutterbar poly designs. One has poly shoes riveted to steel plates and the other has poly shoes bolted to cutterbar.

#### **For Riveted Cutterbar Poly:**

At R/H outer leg, notch poly wearplate assembly (K) and poly skid shoe (L) as shown below.

**NOTE:** Notches are required for clearance for trans-axle strut hook where it engages the cutterbar in transport.

#### **For Bolt-on Cutterbar Poly:**

Trim poly in area of transaxle strut hook and diagonal brace J-hook using the underside of header as a template.



BLOCK WHEELS TO MOVE PIN TO STORAGE POSITION

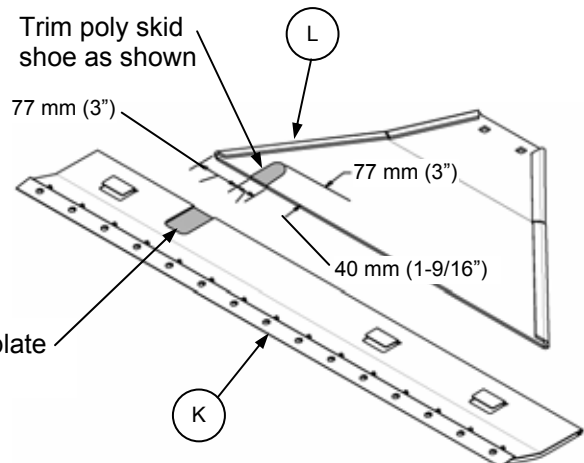
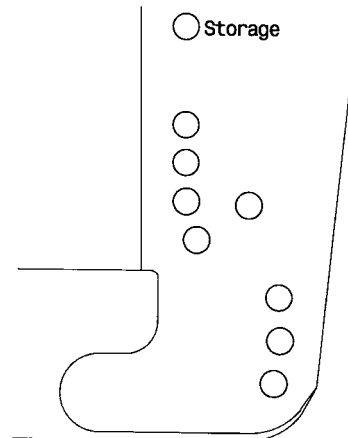

Use notch in steel wearplate as a guide to notch poly

POLY WEARPLATE MODIFICATION FOR 973 & 974 HEADERS (RIVETED STYLE SHOWN)



## TRANSPORT OPTION

### MAINTENANCE / SERVICE

#### 100 Hour or Annual Greasing

Wheel Support Pivots (A) – four fittings  
(2 per wheel support)



WHEEL SUPPORT PIVOTS

#### 500 Hour or Annual Greasing

Wheel Hub Bearings (B) – one fitting per wheel

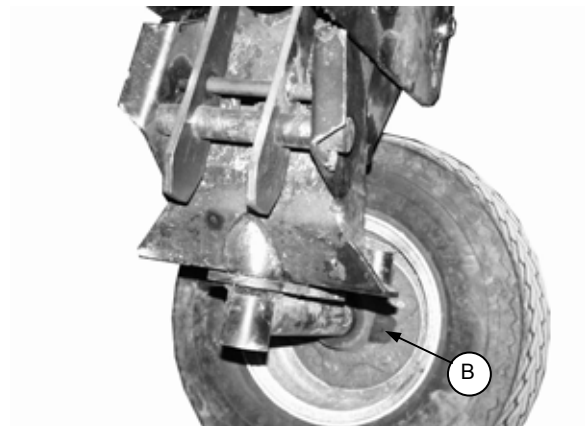

WHEEL HUB BEARINGS

## TRANSPORT OPTION

### MAINTENANCE / SERVICE

#### Wheel Bolts

Check and tighten wheel bolts after the first 10 hours of operation and every 100 hours thereafter.

Whenever a wheel is removed and re-installed, check torque after one hour of operation.

Maintain torque of 80 to 90 ft.lbs. (110 to 120 N-m)

Follow the proper bolt tightening sequence shown.

**NOTE:** When installing wheel, be sure valve stem (C) points away from wheel support.

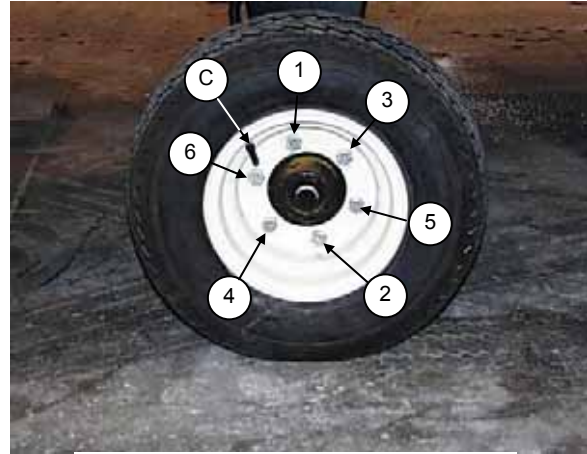

BOLT TIGHTENING SEQUENCE

#### Tire Inflation

Check tire pressure daily. Maintain 100 psi (690 kPa).



**WARNING: Service tires safely. A tire can explode during inflation and cause serious injury or death. Never increase air pressure beyond 35 psi (241 kPa) to seat the bead on the rim. Replace the tire if it has a defect. Replace a wheel rim, which has cracks, wear or severe rust. Never weld a wheel rim. Make sure all the air is removed from a tire before removing the tire from a rim. Never use force on an inflated or partially inflated tire. Make sure the tire is correctly seated before inflating to operating pressure.**

Do not remove, install or make repairs to a tire on a rim unless you have the proper equipment and experience to perform the job. Take the tire and rim to a qualified tire repair shop. If the tire is not in correct position on the rim, or is too full of air, the tire bead can loosen on one side, causing air to leak at high speed and with great force. An air leak of this nature can thrust the tire in any direction, endangering anyone in the area.

(A) - Use a safety cage if available.

(B) - Do not stand over tire. Use a clip-on chuck and extension hose.

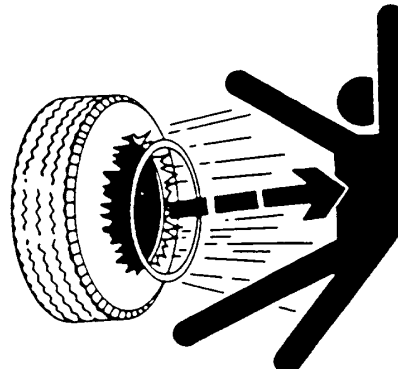

SERVICE TIRES SAFELY

