

**Model 963
30' & 36'
HARVEST HEADERS**

OPERATOR'S MANUAL

Inside Front Cover
(blank)

INTRODUCTION

Your new 963 Harvest Header is designed to serve a dual function in your grain and specialty crop harvesting operation:

1. Teamed with your self-propelled windrower power unit, the header will cut and lay crop into uniform fluffy windrows. Windrowing allows starting the harvest earlier, protects the crop from wind damage, and gives you more flexibility in scheduling combine time. (The left deck of the 963 Header can be manually shifted over the center opening to deliver crop to the end of the header, which allows using your combine as the power unit when windrowing.)
2. When conditions are right for straight cutting, the header can quickly be attached directly to your combine with the addition of an adapter. When weather is not a critical factor, straight cutting eliminates the windrowing operation.

NOTE: This manual contains information on the Harvest Header. It must be used in conjunction with your Windrower, Tractor and/or Combine Operator's Manual. As well, a separate manual is provided for the adapter that is required to allow attachment of the header to the various makes and models of combines and tractors.

CAREFULLY READ ALL MANUALS TO BECOME FAMILIAR WITH RECOMMENDED PROCEDURES BEFORE ATTEMPTING TO UNLOAD, ASSEMBLE OR USE THE MACHINE.

Use this manual as your first source of information about the header. If you follow the instructions given in this manual your Harvest Header will work well for many years.

This manual contains information on "Safety", "Operation" and "Maintenance/Service". In addition, "Unloading and Assembly" instruction is given towards the back of this book.

Use the Table of Contents and the Index to guide you to specific areas. Study the Table of Contents to familiarize yourself with how the material is organized.

Keep this manual handy for frequent reference and to pass on to new operators or owners. Call your dealer if you need assistance, information or additional copies of the manual.

NOTE: Right hand (R/H), and Left hand (L/H) designations are determined from the operators position, facing forward.



TABLE OF CONTENTS

INTRODUCTION	1
SERIAL NUMBER LOCATION	4
SAFETY	
Safety Alert Symbol	4
Signal Words	5
Safety Signs	6
General Farm Safety	7,8
SPECIFICATIONS	
963 Harvest Header	9
Hardware Torque Specifications	10
Hydraulic Fittings Torque Specifications	11
HEADER OPERATION	
Your Responsibilities as an Owner/Operator	12
Break-In Period	13
Pre-Starting Checks: Annual	14
Pre-Starting Checks: Daily	14
Operate Correctly	15
Header Controls	16
Header Lift Cylinder Stops	16
Reel Props	16
Operating Variables	
Ground Speed	17
Cutting Height	18
Gauge Wheel Field Positions	18
Skid Shoes (Attachment)	19
Header Flotation	20
Header Angle	21
Draper Speed	21
Delivery Opening Width	21-23
End Delivery	24
Reel Speed / Reel Height / Reel Position - Fore & Aft	25
Divider Angle	26
Shut-Down Procedure	26
Windrowing	
Effects of Operating Variables on Windrow Formation	27,28
Windrow Characteristics	29,30
TRANSPORT	
Transporting the Header on Windrower or Combine	31
Gauge Wheel / Transport Option	
Converting from Field Position to Transport	32,33
Attaching to Towing Vehicle	34
Towing the Header	34
Converting from Transport to Field Position	35,35
STORAGE	
Storage Procedure	36

TABLE OF CONTENTS

MAINTENANCE/SERVICE	
Service Procedures	37
Closing L/H Drive Shield	37
Recommended Lubricants	38
Enclosed Drive Lubricant Capacities	38
Sealed Bearing Installation	38
Greasing the Header	39-41
Hydraulic System	
Hydraulic System Safety	41
Hoses and Lines	41
Hydraulic Schematic	42
Electrical	42
Sickle and Sickle Drive	
Sickle Lubrication	43
Sickle Sections	44
Sickle Removal and Installation	44,45
Sickle Head Needle Bearing Installation	45
Spare Sickle Storage	45
Sickle Guards and Hold-Downs	46
Sickle Drive Belt Tension	47
Wobble Box	47
Drapers	
Draper Tension Adjustment	48
Replacing Drapers	48
Moving Draper Motors	48
Draper Drive and Idler Rollers	49
Installation of Draper Seals	49
Reel and Reel Drive	
Reel Clearance from Cutterbar	50
Centering the Reel	50
Reel Drive Chain	51
Gauge Wheels	
Wheel Bolts	51
Gauge Wheel/Transport Casters	51
Tire Inflation and Safety	52
Maintenance Schedule	53
Maintenance Record	54
TROUBLE SHOOTING	
Crop Loss at Cutterbar	55
Cutting Components	55-57
Reel	57,58
Drapers	58
Windrow Formation	59
OPTIONS AND ATTACHMENTS	
Pick-Up Reel, Gauge Wheels, Gauge Wheel/Transport Option	60
Skid Shoes, Hydraulic Reel Fore-Aft Kit, Reel Arm Slope Kit	61
UNLOADING AND ASSEMBLY	
Unloading	62
Assembling Header	63-74
Preparing Header For Combine	75
Converting Sickle Drive Assembly	76,77
Moving Draper Motors Inboard/Outboard	78,79
Adjustments and Checks	80
Hydraulic Fore-Aft Reel Positioner (Option) Assembly	81-84
INDEX	85,86

SERIAL NUMBER LOCATION

Record the serial number in the space provided.

Harvest Header: _____

Plate is located on gusset at left hand end sheet, near main tube.

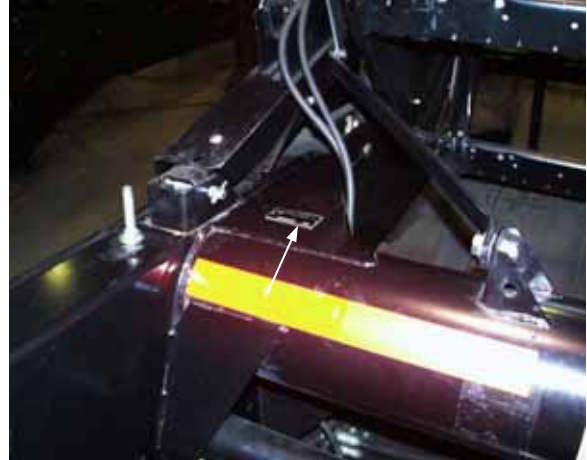

HEADER SERIAL PLATE

NOTE: When ordering parts and service, be sure to give your dealer the complete and proper serial number.

SAFETY

SAFETY ALERT SYMBOL



This safety alert symbol indicates important safety messages in this manual and on safety signs on the header.

This symbol means: ATTENTION !
 BECOME ALERT !
 YOUR SAFETY IS INVOLVED !

Carefully read and follow the safety message accompanying this symbol.

Why is SAFETY important to you?

- 3 BIG REASONS
- ACCIDENTS DISABLE AND KILL
 - ACCIDENTS COST
 - ACCIDENTS CAN BE AVOIDED

SAFETY

SIGNAL WORDS

Note the use of the signal words DANGER, WARNING, and CAUTION with safety messages. The appropriate signal word for each message has been selected using the following guidelines:



DANGER – Indicates an imminently hazardous situation that, if not avoided, will result in death or serious injury.



WARNING – Indicates a potentially hazardous situation that, if not avoided, could result in death or serious injury. It is also used to alert against unsafe practices.



CAUTION – Indicates a potentially hazardous situation that, if not avoided, may result in minor or moderate injury. It is also used as a reminder of good safety practices.

SAFETY SIGNS

- The safety signs reproduced below and on the next page appear on the header at the locations listed.
- Keep safety signs clear and legible at all times.
- Replace safety signs that are missing or become illegible.
- If original parts on which a safety sign was installed are replaced, be sure the repair part also bears the current safety sign.
- Safety signs are available from your Dealer Parts Department.

To install safety signs:

1. Be sure the installation area is clean and dry.
2. Decide on the exact position before you remove the backing paper.
3. Remove the smaller portion of the split backing paper.
4. Place the sign in position and slowly peel back the remaining paper, smoothing the sign as it is applied.
5. Small air pockets can be smoothed out or pricked with a pin.



DRIVELINE

SAFETY

SAFETY SIGNS



HEADER FRAME



BACK TUBE

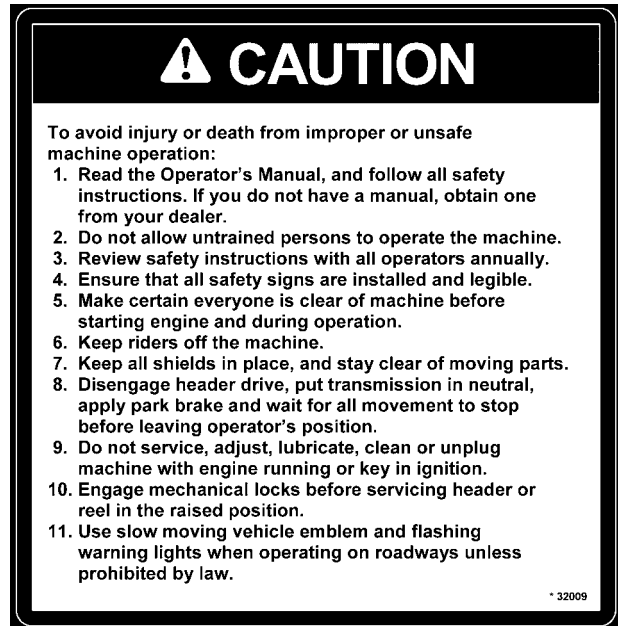

BACK TUBE

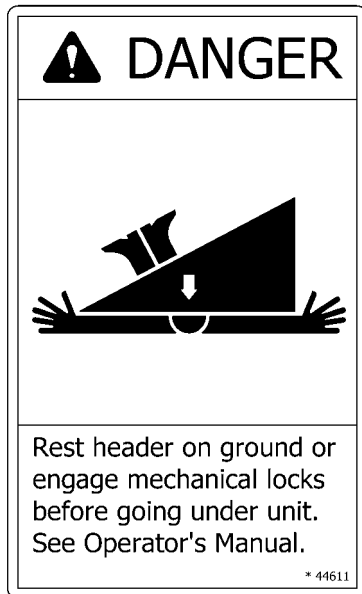

BACK TUBE

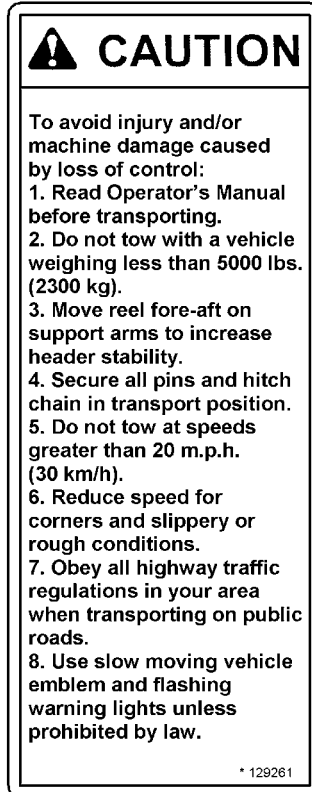

HITCH
(TRANSPORT OPTION)



R/H WHEEL BEAM
(TRANSPORT OPTION)

SAFETY

GENERAL SAFETY



The following are general farm safety precautions that should be part of your operating procedure for all types of machinery.

1. Protect yourself.

When assembling, operating and servicing machinery, wear all the protective clothing and personal safety devices that **COULD** be necessary for the job at hand. Don't take chances.

You may need:

- a hard hat.
- protective shoes with slip resistant soles.
- protective glasses or goggles.
- heavy gloves.
- wet weather gear.
- respirator or filter mask.
- hearing protection. Be aware that prolonged exposure to loud noise can cause impairment or loss of hearing. Wearing a suitable hearing protective device such as ear muffs (A) or ear plugs (B) protects against objectionable or loud noises.

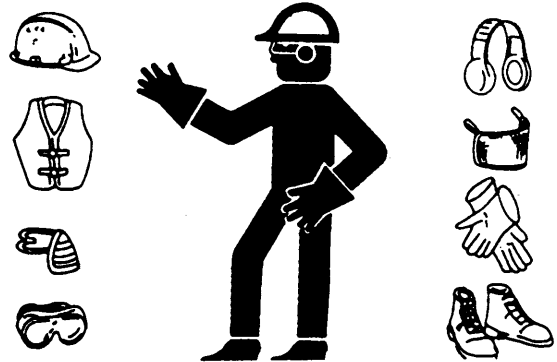

PROTECT YOURSELF

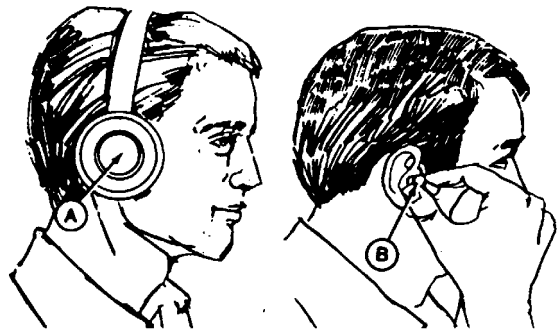

PROTECT AGAINST NOISE

2. Provide a first-aid kit for use in case of emergencies.

3. Keep a fire extinguisher on the machine. Be sure the extinguisher is properly maintained and be familiar with its proper use.

4. Keep young children away from machinery at all times.

5. Be aware that accidents often happen when the operator is tired or in a hurry to get finished. Take the time to consider the safest way. Never ignore warning signs of fatigue.

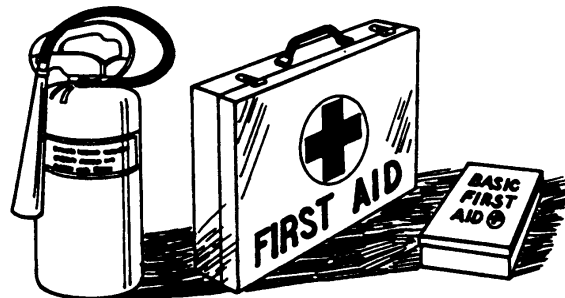

BE PREPARED FOR EMERGENCIES

SAFETY



GENERAL SAFETY (continued)

6. Wear close-fitting clothing and cover long hair. Never wear dangling items such as scarves or bracelets.
7. Keep hands, feet, clothing and hair away from moving parts. Never attempt to clear obstructions or objects from a machine while the engine is running.
8. Keep all shields in place. Never alter or remove safety equipment. Make sure driveline guards can rotate independent of the shaft and can telescope freely.
9. Use only service and repair parts made or approved by the equipment manufacturer. Substituted parts may not meet strength, design, or safety requirements.
10. Do not modify the machine. Unauthorized modifications may impair the function and/or safety and affect machine life.
11. Stop engine and remove key from ignition before leaving operator's seat for any reason. A child or even a pet could engage an idling machine.
12. Keep the area used for servicing machinery clean and dry. Wet or oily floors are slippery. Wet spots can be dangerous when working with electrical equipment. Be sure all electrical outlets and tools are properly grounded.
13. Use adequate light for the job at hand.
14. Keep machinery clean. Straw and chaff on a hot engine are a fire hazard. Do not allow oil or grease to accumulate on service platforms, ladders or controls. Clean machines before storage.
15. Never use gasoline, naphtha or any volatile material for cleaning purposes. These materials may be toxic and/or flammable.
16. When storing machinery, cover sharp or extending components to prevent injury from accidental contact.



NEVER WEAR LOOSE
OR DANGLING CLOTHES

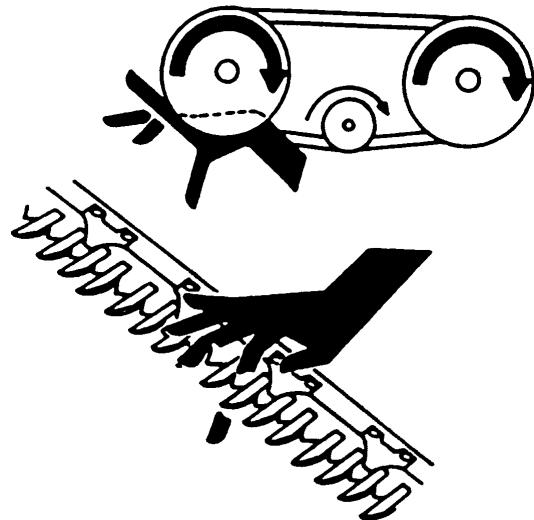

KEEP AWAY FROM MOVING PARTS



KEEP SERVICE AREA CLEAN AND DRY

SPECIFICATIONS

963 HARVEST HEADER

	WINDROWER	COMBINE
		(Specs listed may vary depending on combine)
SICKLE DRIVE	"C" belt to single wobble box (enclosed oil bath)	
SICKLE SPEED	1300 strokes/minute	1240-1345 strokes/minute
SICKLE TYPE	Over-serrated, bolted sections	
DELIVERY OPENING WIDTH (between rollers)	35" (890 mm) to 66" (1676 mm)	
DELIVERY OPENING HEIGHT at 8" (200 mm) cutting height	34" to 37" (880 to 950 mm)	
CUTTERBAR RANGE ground to guard tip, (varies with guard angle and options)	2.5" (65 mm) below ground to 42" (1080 mm) above	determined by combine
GUARD & DRAPER ANGLE: - at 8" (200 mm) cutting height - with cutterbar on ground	9° to 13° 13° to 21°	13° to 18°
DRAPER TYPE	Self-tracking rubber coated polyester with rubber slats	
DRAPER WIDTH	41.5" (1055 mm)	
DRAPER DRIVE	Hydraulic	
DRAPER SPEED	170 to 500 ft./minute (50 to 155 m/min.)	0 to 450 ft./minute (135 m/min.)
FEEDER DRAPER SPEED		see Adapter Manual
FEEDER AUGER SPEED		see Adapter Manual
REEL TYPE	5 Bat metal, <u>or</u> Cam action pick-up reel	
REEL DRIVE	Hydraulic	
REEL SPEED	20 to 60 RPM	determined by combine
HEADER FLOTATION		see Adapter Manual
GAUGE WHEELS (no transport package) Recommended Pressure	6.70-15 I1 Rib Implement 24 to 28 psi (165 to 195 kPa)	
TRANSPORT PACKAGE GAUGE WHEELS Recommended Pressure	9.5L-14 8 ply I1 Rib Implement 42 to 46 psi (290 to 315 kPa)	
HEADER WEIGHT (Sample weights shown are without adapter and will vary with attachments)		
30 ft. with bat reel, without gauge wheels	3060 lbs. (1388 kg)	
30 ft. with pick-up reel and gauge wheels	3560 lbs. (1615 kg)	
36 ft. with bat reel and gauge wheels	3760 lbs. (1706 kg)	
36 ft. with pick-up reel and transport package	4484 lbs. (2034 kg)	

(SPECIFICATIONS AND DESIGN ARE SUBJECT TO CHANGE WITHOUT NOTICE OR OBLIGATION TO REVISE PREVIOUS UNITS.)

TORQUE SPECIFICATIONS

CHECKING BOLT TORQUE

The tables shown below give correct torque values for various bolts and capscrews. Tighten all bolts to the torques specified in chart unless otherwise noted throughout this manual. Check tightness of bolts periodically, using bolt torque chart as a guide. Replace hardware with the same strength bolt.

ENGLISH TORQUE SPECIFICATION

Bolt Dia. "A"	NC Bolt Torque*			
	SAE 5		SAE 8	
	N·m	[lb-ft]	N·m	[lb-ft]
1/4"	12	[9]	15	[11]
5/16"	24	[18]	34	[25]
3/8"	43	[32]	56	[41]
7/16"	68	[50]	95	[70]
1/2"	102	[75]	142	[105]
9/16"	149	[110]	202	[149]
5/8"	203	[150]	271	[200]
3/4"	359	[265]	495	[365]
7/8"	569	[420]	813	[600]
1"	867	[640]	1205	[890]

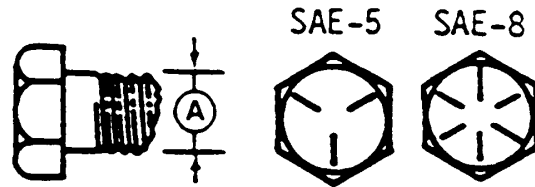

METRIC TORQUE SPECIFICATIONS

Bolt Dia. "A"	Bolt Torque*			
	8.8		10.9	
	N·m	[lb-ft]	N·m	[lb-ft]
M3	0.5	[.4]	1.8	[1.3]
M4	3	[2.2]	4.5	[3.3]
M5	6	[4]	9	[7]
M6	10	[7]	15	[11]
M8	25	[18]	35	[26]
M10	50	[37]	70	[52]
M12	90	[66]	125	[92]
M14	140	[103]	200	[148]
M16	225	[166]	310	[229]
M20	435	[321]	610	[450]
M24	750	[553]	1050	[774]
M30	1495	[1103]	2100	[1550]
M36	2600	[1917]	3675	[2710]

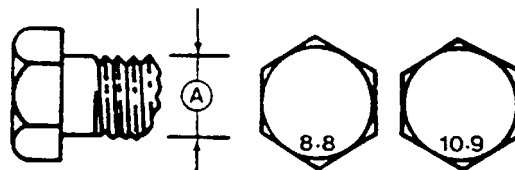

Torque figures indicated above are valid for non-greased or non-oiled threads and heads unless otherwise specified. Do not grease or oil bolts or capscrews unless specified in this manual. When using locking elements, increase torque values by 5%.

* Torque value for bolts and capscrews are identified by their head markings.

TORQUE SPECIFICATIONS

TIGHTENING O-RING FITTINGS*

1. Inspect O-ring and seat for dirt or obvious defects.
2. On angle fittings, back the lock nut off until washer bottoms out at top of groove.
3. Hand tighten fitting until back-up washer or washer face (if straight fitting) bottoms on face and O-ring is seated.
4. Position angle fittings by unscrewing no more than one turn.
5. Tighten straight fittings to torque shown.
6. Tighten angle fittings to torque shown while holding body of fitting with a wrench.

* The torque values shown are based on lubricated connections as in reassembly.

Thread Size (in.)	Nut Size Across Flats (in.)	Torque Value*		Recommended Turns to Tighten (after finger tightening)	
		N·m	[lb-ft]	Flats	Turns
3/8	1/2	8	[6]	2	1/3
7/16	9/16	12	[9]	2	1/3
1/2	5/8	16	[12]	2	1/3
9/16	11/16	24	[18]	2	1/3
3/4	7/8	46	[34]	2	1/3
7/8	1	62	[46]	1-1/2	1/4
1-1/16	1-1/4	102	[75]	1	1/6
1-3/16	1-3/8	122	[90]	1	1/6
1-5/16	1-1/2	142	[105]	3/4	1/8
1-5/8	1-7/8	190	[140]	3/4	1/8
1-7/8	2-1/8	217	[160]	1/2	1/12

TIGHTENING FLARE TYPE TUBE FITTINGS*

1. Check flare and flare seat for defects that might cause leakage.
2. Align tube with fitting before tightening.
3. Lubricate connection and hand tighten swivel nut until snug.
4. To prevent twisting the tube(s), use two wrenches. Place one wrench on the connector body and with the second, tighten the swivel nut to the torque shown.

* The torque values shown are based on lubricated connections as in reassembly.

Tube Size O.D. (in.)	Nut Size Across Flats (in.)	Torque Value*		Recommended Turns to Tighten (after finger tightening)	
		N·m	[lb-ft]	Flats	Turns
3/16	7/16	8	[6]	1	1/6
1/4	9/16	12	[9]	1	1/6
5/16	5/8	16	[12]	1	1/6
3/8	11/16	24	[18]	1	1/6
1/2	7/8	46	[34]	1	1/6
5/8	1	62	[46]	1	1/6
3/4	1-1/4	102	[75]	3/4	1/8
7/8	1-3/8	122	[90]	3/4	1/8

OPERATION

YOUR RESPONSIBILITIES AS AN OWNER/OPERATOR



CAUTION:

1. It is your responsibility to read and understand this manual and the Windrower or Combine Operator's Manual completely before operating the header. Contact your dealer if an instruction is not clear to you.
2. Follow all safety messages in the manuals and on safety signs on the machine.
3. Remember that YOU are the key to safety. Good safety practices protect you and the people around you.
4. Before allowing anyone to operate the machine, for however short a time or distance, make sure they have been instructed in its safe and proper use.
5. Review the manual and all safety related items with all operators annually.
6. Be alert for other operators not using recommended procedures or not following safety precautions. Correct these mistakes immediately, before an accident occurs.
7. Do not modify the machine. Unauthorized modifications may impair the function and/or safety and affect machine life.
8. The safety information given in this manual does not replace safety codes, insurance needs, or laws governing your area. Be sure your machine meets the standards set by these regulations.



READ THE OPERATOR'S MANUAL

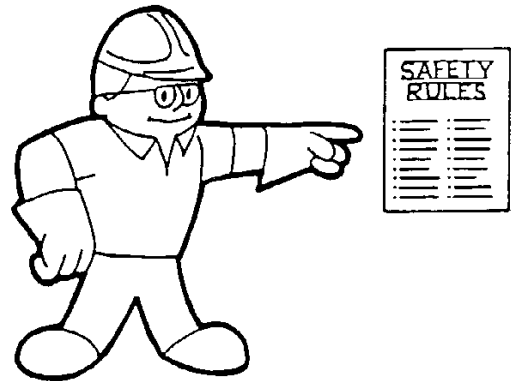

FOLLOW SAFETY RULES

TO THE NEW OPERATOR

It's natural for an operator to be anxious to get started with a new machine. Please take the time to familiarize yourself with the header by reading the Operator's Manuals and safety signs before attempting operation.

HEADER OPERATION

BREAK-IN PERIOD

1. After attaching header to combine or windrower tractor for the first time, operate the machine with reel, drapers and sickle running slowly for 5 minutes, watching and listening FROM THE OPERATOR'S SEAT for binding or interfering parts.



CAUTION: Before investigating an unusual sound or attempting to correct a problem, shut off engine, engage parking brake and remove key.

NOTE: Reel and side drapers will not operate until oil flow fills the lines.

2. Change hydraulic oil filter(s) as recommended in combine or windrower tractor Operator's Manual.
3. Adjust the tension of sickle drive belt (A) after a 5 hour run-in period. (See Maintenance/ Service section, page 47.) Continue to check the belt tension periodically for the first 50 hours.
4. Tighten any loose hardware after the first 5 hours operation. See Specifications section, page 10 for recommended torque values.
5. For headers with gauge wheels, check gauge wheel bolt torque after the first 10 hours operation and periodically thereafter (at least every 100 hours). Torque:
4 bolt hub - 50 to 60 ft.lbs. (70 to 80 N·m)
6 bolt hub - 80 to 90 ft.lbs. (110 to 120 N·m)
6. Tighten the four wobble box mounting bolts (B) after the first 10 hours operation and every 100 hours thereafter. Torque to 200 ft.lbs. (270 N·m), starting with the side mounting bolts.
7. Change wobble box lubricant after the first 50 hours operation and every 1000 hours (or 3 years) thereafter. See Maintenance/Service section, page 47.

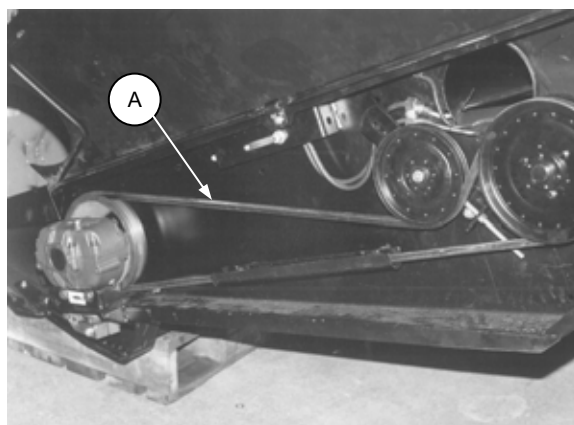

CHECK SICKLE DRIVE BELT TENSION

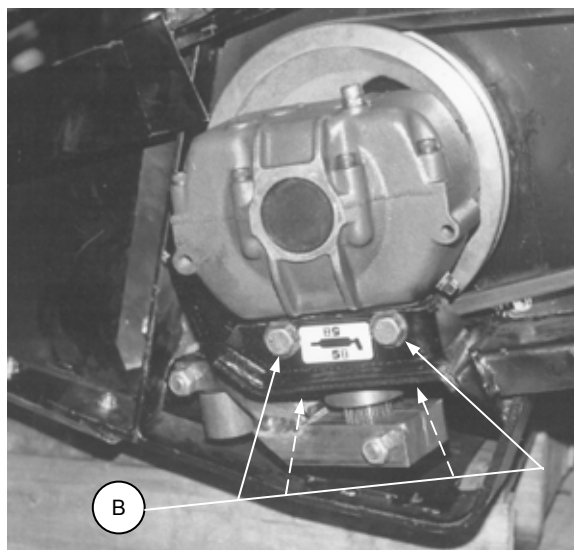

TIGHTEN FOUR WOBBLE BOX MOUNTING BOLTS

HEADER OPERATION

PRE-STARTING CHECKS: ANNUAL

Do the following at the start of each operating season.



CAUTION:

1. Review the Operator's Manuals to refresh your memory on safety and operating recommendations.
2. Review all safety signs and other decals on the machine and note hazard areas.
3. Be sure all shields and guards are properly installed and secured. Never alter or remove safety equipment.
4. Be sure you understand and have practised safe use of all controls. Know the capacity and operating characteristics of the machine.
5. Check the first aid kit and fire extinguisher. Know where they are and how to use them.

Also:

6. Install drapers. See "Drapers" in Maintenance /Service section, page 48.
7. Adjust belt, draper and chain tension. See Maintenance/Service section.
8. Perform all Annual Maintenance. See Maintenance/Service section, page 53.

PRE-STARTING CHECKS: DAILY

Do the following each day before start-up:



CAUTION:

1. Clear the area of other persons, pets etc. Keep children away from machinery. Walk around the header to be sure no one is under, on or close to it.
2. Remove foreign objects from the machine and surrounding area.
3. Wear close fitting clothing and protective shoes with slip resistant soles. As well, carry with you any protective clothing and personal safety devices that **COULD** be necessary through the day. Don't take chances.

You may need:

- hard hat
- protective glasses
- heavy gloves
- respirator or filter mask
- wet weather gear.



4. Protect against noise. Wear a suitable hearing protective device such as ear muffs or ear plugs to protect against objectionable or uncomfortably loud noises.
5. Check the machine for leaks or any parts that are missing, broken, or not working correctly.

NOTE: Use proper procedure when searching for pressurized fluid leaks. See "Hydraulic System" in Maintenance/Service section, page 41.

6. Clean all lights and reflective surfaces on the machine.
7. Perform all Daily maintenance. See Maintenance/Service section, page 53.

HEADER OPERATION

OPERATE CORRECTLY



CAUTION:

1. Follow all safety and operational instructions given in your Operator's Manuals. If you do not have a windrower tractor and/or combine manual, get one from your dealer and read it thoroughly.
2. Never attempt to start the engine or operate the machine except from the operator's seat.
3. Check the operation of all controls in a safe clear area before starting work.
4. Do not allow riders on windrower or combine.
5. Never start or move the machine until you are sure all bystanders have cleared the area.
6. Avoid travelling over loose fill, rocks, ditches or holes.
7. Drive slowly through gates and doorways.
8. When working on inclines, travel uphill or downhill when possible. Be sure to keep transmission in gear when travelling downhill.
9. Never attempt to get on or off a moving machine.
10. Do not leave the operator's station while the engine is running.
11. Stop engine and remove key before adjusting or removing plugged material from the machine. A child or even a pet could engage the drive.
12. Check for excessive vibration and unusual noises. If there is any indication of trouble, shut-down and inspect the machine. Follow proper shutdown procedure:
 - engage brake
 - disengage header drive
 - turn off engine and remove key
 - wait for all movement to stop
 - dismount and engage cylinder stops before inspecting raised machine.
13. Operate only in daylight or good artificial light.



DO NOT ALLOW RIDERS

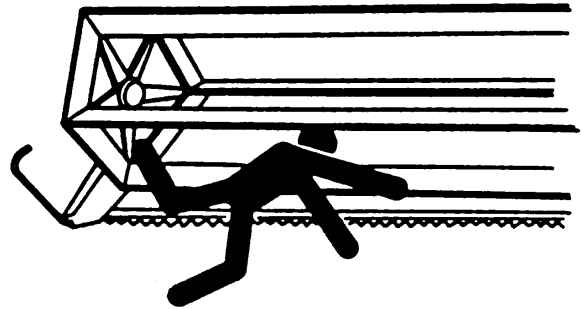

CLEAR THE AREA BEFORE OPERATING

HEADER OPERATION

HEADER CONTROLS



CAUTION: Be sure all bystanders are clear of machine before starting engine or engaging any header drives.

See your Windrower Tractor or Combine Operator's Manual for identification of in-cab controls for:

- Header Drive Clutch
- Header Height
- Ground Speed
- Reel Speed
- Reel Height

HEADER LIFT CYLINDER STOPS



DANGER: To avoid bodily injury or death from fall of raised header, always engage cylinder stops before going under header for any reason. See your Windrower Tractor or Combine Operator's Manual for instruction regarding the use and storage of header lift cylinder stops.

REEL PROPS



WARNING: To avoid bodily injury from fall of raised reel, always engage reel props before going under raised reel for any reason.

IMPORTANT: To prevent damage to reel support arms, do not transport header with reel props engaged.

Reel props are located at each reel support arm.

To engage reel props:

1. Raise reel to maximum height.
2. Move props (B) to engaged position.
3. Lower reel until props contact end frames.

NOTE: Keep pivot bolt (C) properly tightened so prop remains in stored position when not in use, yet can be engaged with hand force.

For 36 foot header, be sure hoses are positioned to pass through slot (D) in center arm prop.

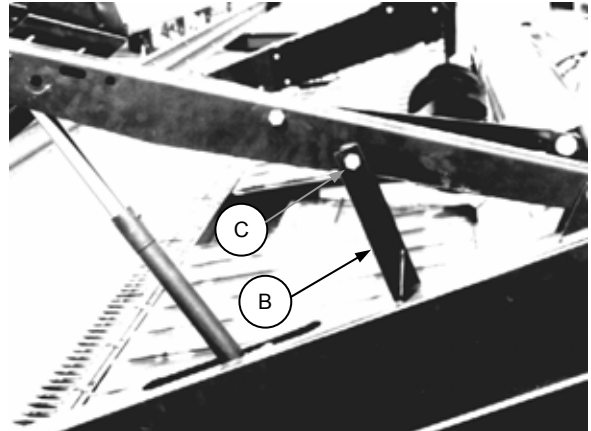

REEL PROP - ENGAGED

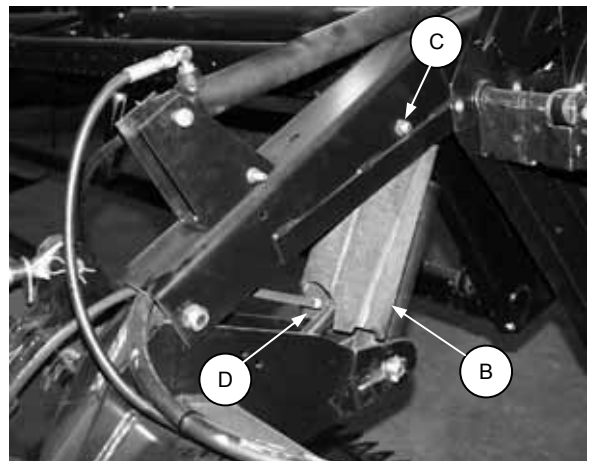

36 FT. CENTER ARM
REEL PROP - ENGAGED

HEADER OPERATION

Operating Variables

Satisfactory function of the header requires making the proper adjustments to suit various crops and conditions.

Correct operation reduces crop loss and allows cutting of more acres. As well, proper adjustments and timely maintenance will increase the length of service you receive from the machine.

The variables listed at right will affect the performance of the header. You will quickly become adept at adjusting the machine to give you the desired results.

OPERATING VARIABLES

1. Ground Speed
2. Cutting Height
3. Header Flotation
4. Header Angle
5. Draper Speed
6. Delivery Opening Width
7. Reel Speed
8. Reel Height
9. Reel Fore-Aft Position
10. Divider Angle

GROUND SPEED

- Ground speed should be such that the sickle can cut crop smoothly and cleanly, while giving the desired delivery of material to the opening. Excessive ground speed results in "ragged" cutting. See "Windrowing" for affects of ground speed on windrow formation.
- In tough-to-cut crops like flax, reduce ground speed to reduce loads on cutting components and drives.
- Higher ground speeds require heavier float settings to prevent excessive bouncing. This will result in increased cutting component damage.
- As ground speed is increased, draper and reel speed should be increased to handle the extra material.

The chart below indicates the relationship between ground speed and area cut for the two header sizes.

Example shown: At a ground speed of 5 miles per hour (8 km/h) with a 36 ft. header, the area cut would be approximately 22 acres (9 hectares) per hour.

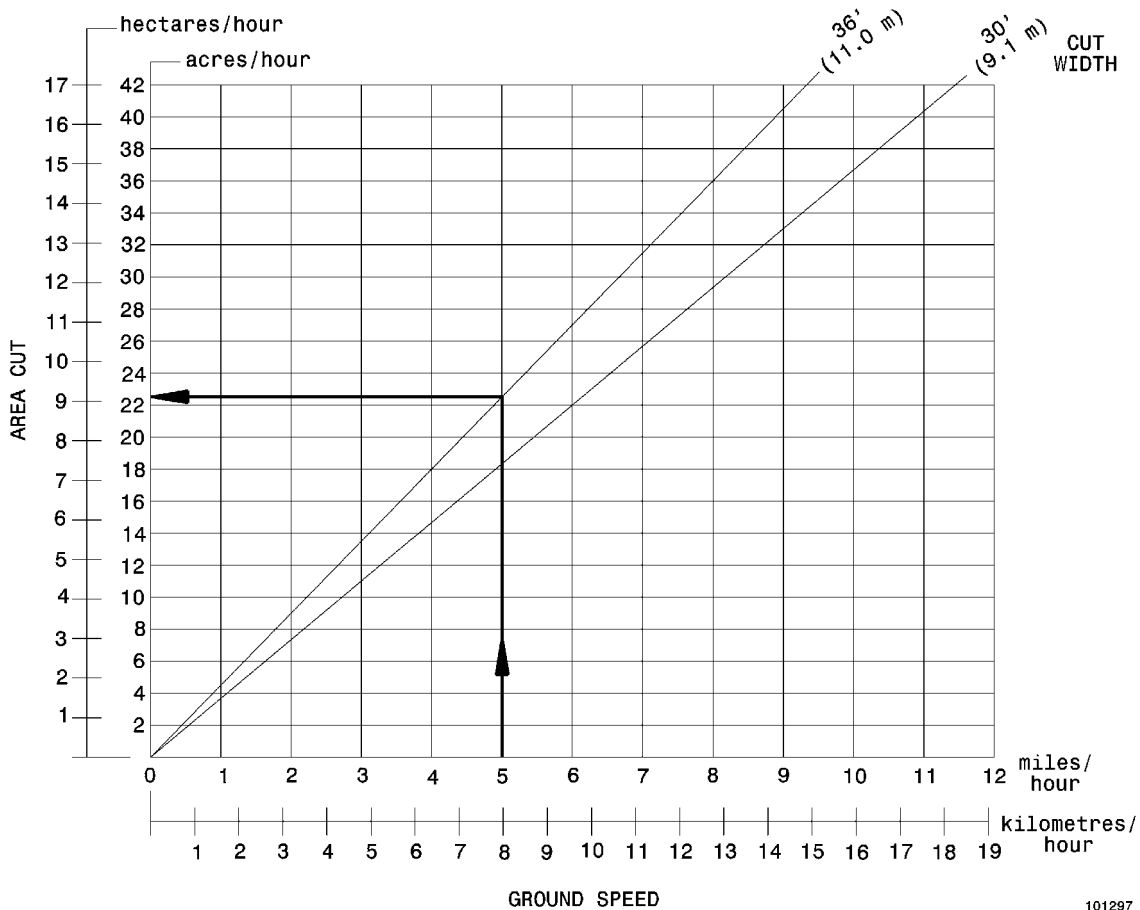

HEADER OPERATION

Operating Variables (continued)

CUTTING HEIGHT

Cutting height will vary, depending on whether windrowing or straight-cutting, type of crop, etc. See "Windrowing" for stubble height recommendations.

Gauge Wheel Field Positions:

For headers equipped with gauge wheels or the gauge wheel/transport package, choose Field Position 1 or 2 to maintain proper gauge wheel spring force at desired cutting height.

Field Position 1 when cutterbar is above the ground (4 to 12 in. [100 to 300 mm] cutting height).

Field Position 2 when cutterbar is on the ground (0 to 4 in. [100 mm] cutting height).

NOTE: When changing gauge wheel field position, readjust header flotation. See "Header Flotation" in Windrower Tractor or Combine Adapter Operator's Manual.

NOTE: Gauge wheel field position should also be related to Header Angle. Use Position 2 for flatter header angles and Position 1 for steeper header angles.

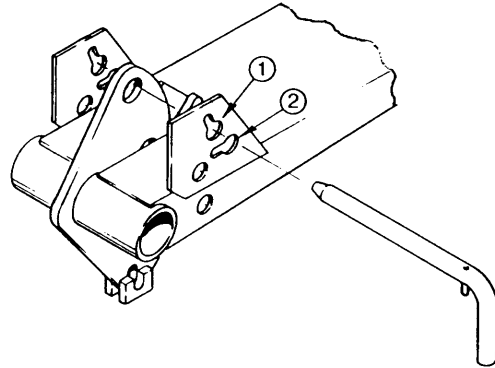

STANDARD GAUGE WHEEL SUPPORT

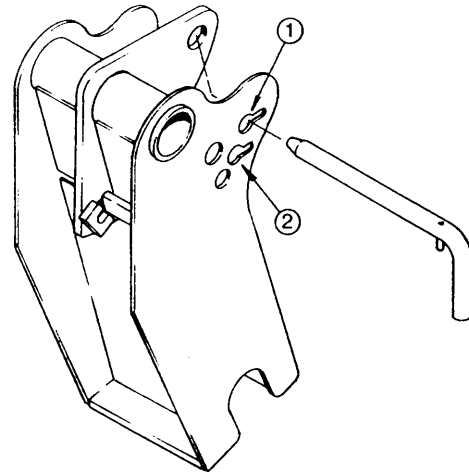

TRANSPORT PACKAGE -
LEFT WHEEL SUPPORT

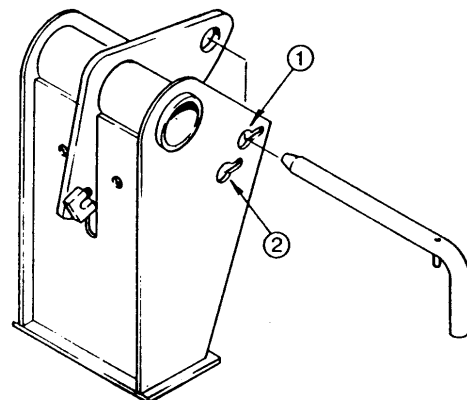

TRANSPORT PACKAGE -
RIGHT WHEEL BEAM SUPPORT

HEADER OPERATION

Operating Variables

CUTTING HEIGHT (continued)

Skid Shoes (Attachment)

Skid shoes are available as an attachment. The primary benefits of skid shoes are:

1. Help prevent damage to cutting components.
2. Reduce scooping of dirt onto cutterbar.
3. Provide a method of setting a minimum cutting height.

To adjust skid shoes:

1. Raise header and engage lift cylinder stops.



DANGER: To avoid bodily injury or death from fall of raised header, always engage cylinder stops before going under header.

2. Remove one of the guard bolts securing support (S).
3. Remove rods from supports and position shoe at desired setting. Adjust both shoes to the same position to provide an even cutting height.

NOTE: When using the "flattest" setting, (Position 1), ensure angle (A) is removed to prevent draper damage.

4. Replace rods in supports and replace guard bolt.

NOTE: The skid shoe kit includes two shoes. Additional skid shoes may be installed if required.

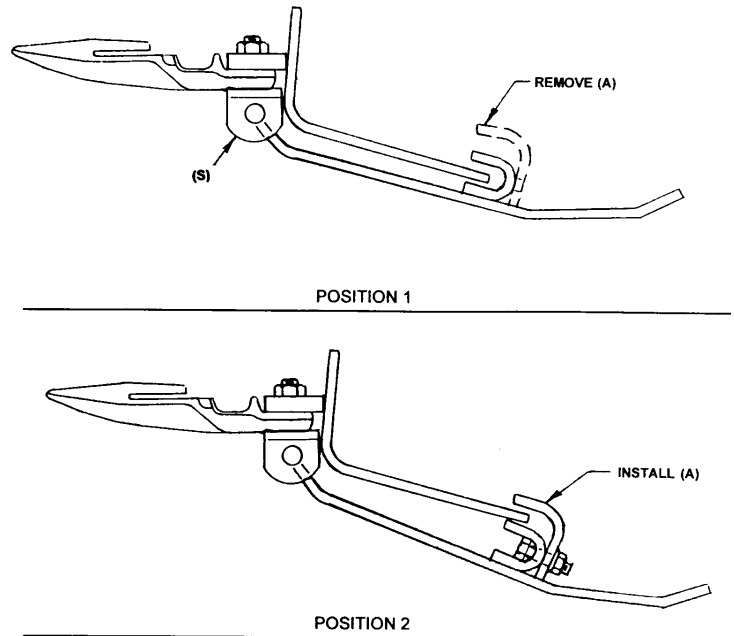

SKID SHOE POSITIONS

HEADER OPERATION

Operating Variables (continued)

HEADER FLOTATION

IMPORTANT: To avoid frequent breakage of sickle components, scooping soil, or soil build-up at cutterbar in wet conditions, set header float as light as possible without causing excessive bouncing.

Under normal conditions, adjust float spring tension so 50 to 70 lbs. force (220 to 310 N) is required to lift cutterbar off ground at each end.

See "Header Flotation" in Windrower or Combine Adapter Operator's Manual for adjustment details.

For Windrower Headers with gauge wheels, follow procedure below:

GAUGE WHEEL/TRANSPORT WHEEL SETTING PROCEDURE:

1. Set guard angle and reel to desired position for cutting conditions.
2. Choose gauge wheel position to maintain proper gauge wheel spring force at desired cutting height.

Field Position 1: when cutter bar is above the ground (4-12 inches (100–300 mm) cutting height)

Field Position 2: when cutter bar is above the ground (2-5 inches (50-125 mm) cutting height)

Storage (locked out): when cutter bar is on the ground (0-2 inches (0-50mm) cutting height. Header is run on skid shoes and height is controlled by guard angle.

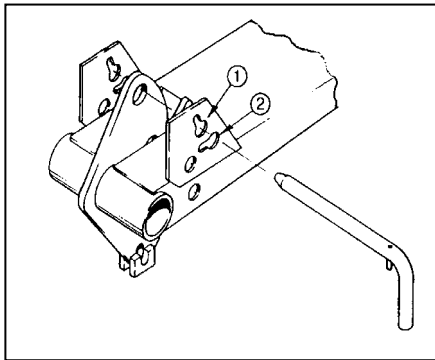

Standard Gauge Wheel Support

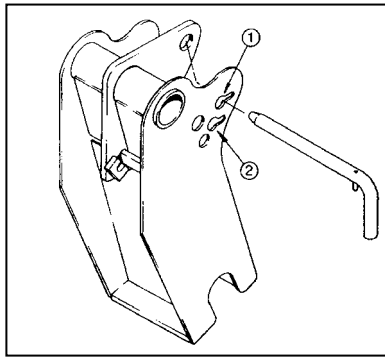

Transport Package – Left Wheel Support

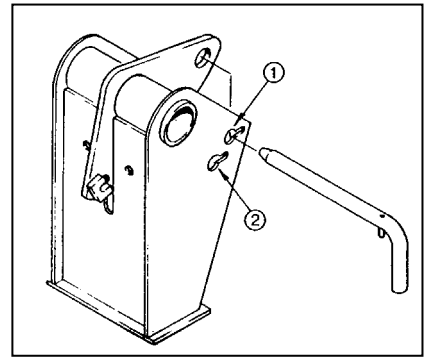

Transport Package – Right Wheel Beam Support

3. Position the header at desired cutting height with gauge wheel pins installed in the appropriate position.

At this position inspect the gap at (C) to ensure that the gauge wheel springs are not pushing the header off the float down-stop pads. If gap at (C) is less than 1 inch (0 – 25 mm) proceed to step 4.

If gap at (C) is larger than 1 inch:

- a.) Lift up on crop divider to check the header's floatation. If float is lighter than 100 lbs (445 N) continue on with setting procedure, if not check to see how many coil springs are installed in the gauge wheels. If two springs are installed remove one spring from each side and repeat step 3.
- b.) If only 1 spring is present in the gauge wheels, move pin to the next available hole. i.e. Move pin from position 1 to position 2 or from position 2 to the stand position.

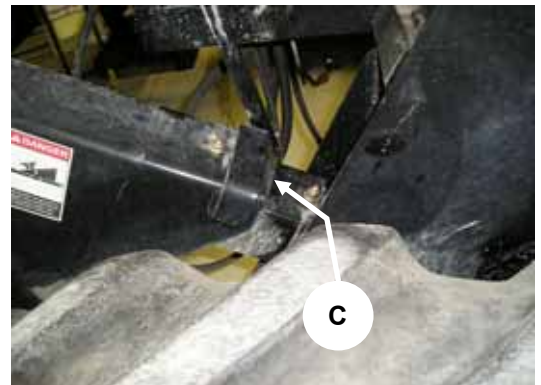

HEADER OPERATION

Operating Variables (continued)

- Adjust float to desired setting while keeping gap less than 1 inch (0-25 mm) gap at (C). Measure gap with header at desired cutting height.

Loosen jam nut (D) and turn adjustment bolt (E) clockwise to increase float.

Loosen jam nut (D) and turn adjustment bolt (E) counterclockwise to decrease float.

Note: Settings require re-adjustment after an adjustment to header angle or reel position.

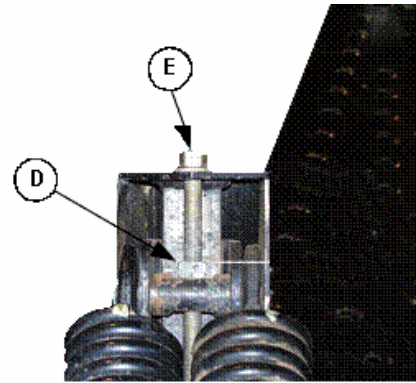

FLOAT ADJUSTMENT

HEADER ANGLE

The header (or guard) angle can be set between 9° and 13° below horizontal on the windrower.

The header (or guard) angle can be set between 13° and 16° below horizontal on the combine. (Actual range may vary with combine set-up.)

IMPORTANT: The flattest header angles are recommended for normal conditions. A flatter header angle reduces sickle section breakage and reduces soil scooping or build-up at the cutterbar in wet conditions. Use a steeper angle to cut very close to the ground, or in down crop for better lifting action.

See "Windrowing" for the effects of header angle on windrow formation. See "Header Angle" in Windrower or Combine Adapter Operator's Manual for adjustment details.

For headers with gauge wheels, see "Gauge Wheel Field Positions", page 18 for proper relationship between gauge wheel setting and header angle.

DRAPER SPEED

Draper speed affects the orientation of stalks in the delivered crop. See "Windrowing", page 27 for the affect of draper speed on windrow formation. See Windrower or Combine Adapter Operator's Manual for adjustment details.

DELIVERY OPENING WIDTH

For windrower, the width and position of the delivery opening affects the width and configuration of the windrow. See "Windrowing", page 27 for more information.

For straight cutting, the side draper opening must be set to properly overlap feeder draper.

The center delivery opening can be adjusted to widths between 32.3" (820 mm) and 65.8" (1670 mm) measured between rollers.

NOTE: End delivery opening size is limited by windrower drive tires and/or deck contacting header frame. When shifting deck to end delivery, ensure center delivery opening size is 61" (1549 mm) or narrower.

To adjust delivery opening width:

- Release draper tension as follows:
 - Loosen bolt (A) and nut (B).
 - Slide bracket (C) towards outboard roller.
- NOTE:** It may be necessary to tap bracket (C) with a hammer to start it moving.

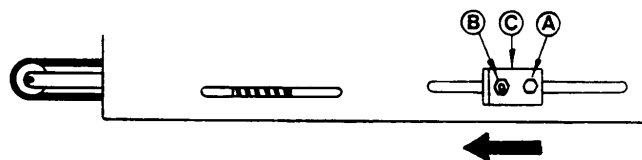

RELEASE DRAPER TENSION

HEADER OPERATION

Operating Variables (continued)

To adjust delivery opening width (continued)

- Remove screws from draper connector slat.
- Use the following chart to position draper connector tubes at the appropriate rows of holes and position rollers at center opening for the desired application.

CONNECTION	CENTER DELIVERY OPENING WIDTH (W) (between rollers)	LEG TO ROLLER EDGE (DIM. X)	DESIGNATED APPLICATION and COMMENTS
Row A to Row F (both drapers)	33.9" (860 mm)	22.4" (568 mm)	Opening for combine models: Case 60 & 66 Series, NH CR 920/940/960 & Gleaner
Row A to Row G (both drapers)	39.7" (1010 mm)	19.4" (493 mm)	Opening for Case 77, 80 & 88 series combines
Row A to Row E (both drapers)	41.7" (1060 mm)	18.4" (468 mm)	Opening for CNH AFX, NH-CR 970/980, Challenger 660 and MF 9690
Row A to Row H (both drapers)	49.6" (1260 mm)	14.4" (365 mm)	Opening for Lexion 450, 460R, 470, 470R, 475, 560, 560R, 570R, 575R, 580, 580R & 585R Combines
Row J to Row D (both drapers)	53.5" (1360 mm)	12.4" (315 mm)	Opening for combine models: JD STS, CTS, 9500, 9510, NH CX, Challenger 670 and MF 9790
Row A to Row C (both drapers)	59.5" (1510 mm)	9.6" (243 mm)	Opening for combine models: JD 9600, 9610, 9650 and Lexion 460, 465, 480, 480R, 485 & 485R Combines
Row A to Row B (both drapers)	65.8" (1670 mm)	6.4" (163 mm)	Maximum opening for windrowing

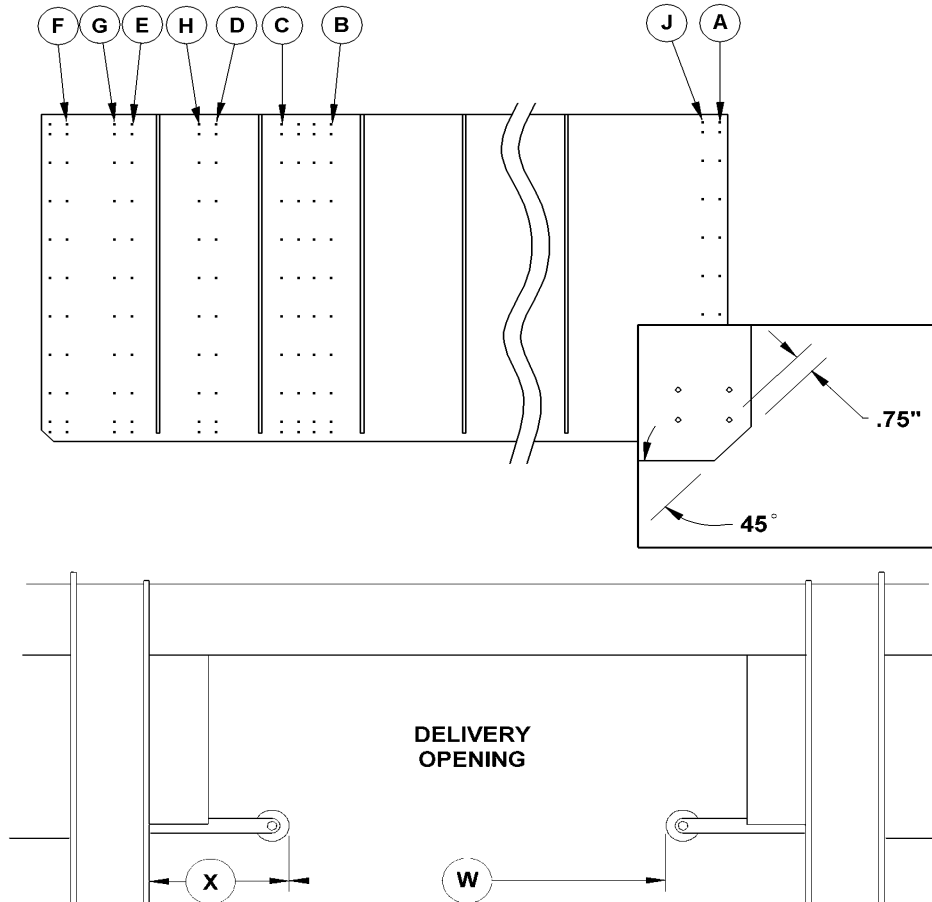

HEADER OPERATION

Operating Variables (continued)

To adjust delivery opening width

3. continued)

Bolt opening adjustment bars to deck at the hole corresponding to the draper row. For example if drapers are to be connected at row E (from chart on previous page), move roller until hole (E) aligns with deck mounting slot. Use a carpenter's square to ensure roller is square to deck and tighten hardware.

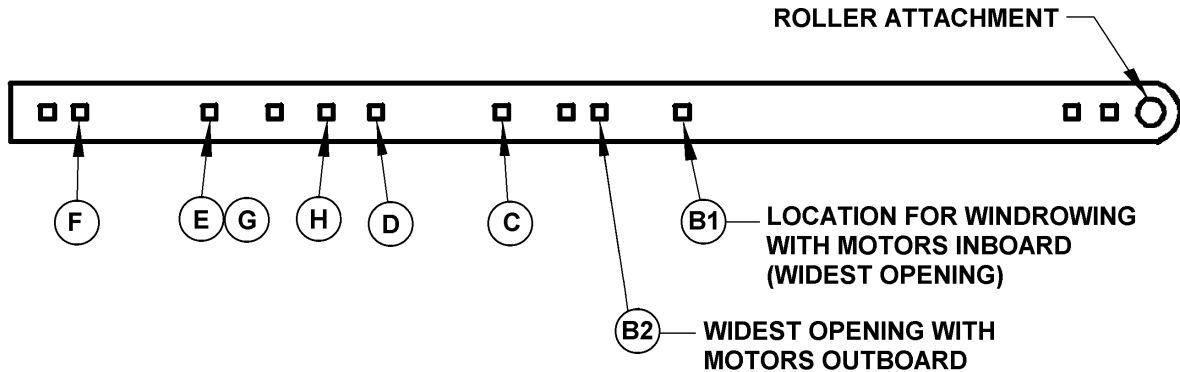

NOTE: For access to bolt securing the adjustment bar at cutterbar on L/H (moveable) deck, remove retainer clips (K) and, if installed, the front edge draper seals and clips (see page 49). Raise front of deck for access to bolt.

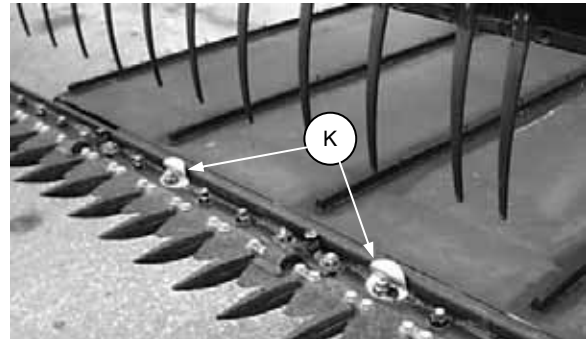

REMOVE CLIPS ON LEFT DECK FOR BOLT ACCESS

4. Cut excessive flap off of draper, leaving 3/8" (10 mm) extending above the connector. Trim the new ends at the front corners as shown on page 22. This allows draper to fit properly under front draper seal to prevent tearing of front edge. Use the cut-offs as a guide for trimming. Keep the cut-offs for use as a splice.

5. **NOTE:** Place connector tube so holes closest to end of tube are at the cutterbar. Connect draper with screw heads facing center opening.

NOTE: To reduce the opening size after it has been enlarged, a short section of draper (available from your dealer) can be added to increase draper length.

6. Slide bracket (C) away from outboard roller as far as hand force allows. Check that draper V-guide (E) is properly engaged in grooves at rear of both rollers.

7. Tighten nut (B) to secure the position of bracket (C).

8. Apply draper tension by turning bolt (A) clockwise until gap between idler spring coils is 1/16 inch (1.5 mm).

IMPORTANT: Do not collapse spring. The spring maintains draper tension and prevents over-tension. If spring is collapsed, damage to draper and rollers may result from excessive draper tension.

9. For narrower opening sizes (roller position E, F or G) backsheet extension panels (L) may be moved inboard to aid feeding. For inboard positions, bolt panel to opening adjustment bar at hole B1.

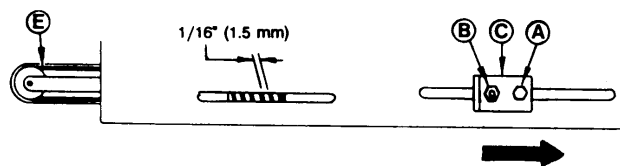
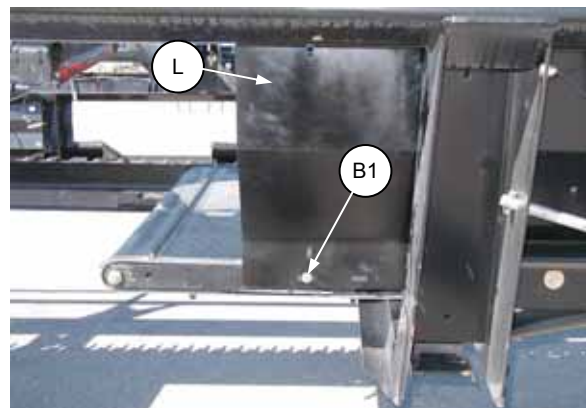

APPLY DRAPER TENSION

HEADER OPERATION

Operating Variables (continued)

END DELIVERY: The left deck of the 963 header can be manually shifted to close off the center opening and deliver crop to the left end of the header. This provides the capability of windrowing with a combine or non-windrower tractor as the power unit.

To shift left deck:

1. Reverse draper travel by disconnecting hydraulic hoses at (B) and connect to opposite lines.
2. Remove deck retainer clips at cutterbar, item (G) on previous page. (If front edge draper seals are installed at cutterbar, remove these seals and clips as well.)
3. For Model 873 Adapters, re-route hydraulic hoses from pump to stop hydraulic flow to the feed draper and drum. See "Windrowing with the Combine" in the 873 Adapter Op. Manual
4. Lower the header to the ground and continue until adapter lowers.
5. Lengthen center link between header and adapter to steepest header angle to increase clearance to header back sheet
6. Loosen bolt securing support (D) at left idler roller (Combine Headers only). Raise support in slot to allow shifting of deck.
7. Loosen bolts (C) at both clamps on left deck. Attach a "Come-Along" from a sickle guard to the deck cross member (A) as shown. Move deck to the right until there is approximately 2 inches (50 mm) clearance between the rollers of the two decks.
8. Tighten bolts (C) at both clamps.
9. Readjust center link to achieve desired header operating angle.
10. Reinstall deck retainer clips (and front edge draper seals, if required).
11. Combine Headers only - To prevent draper damage, lower support (D) in slot at left idler roller until it contacts cutterbar. Tighten bolt.
12. With header and combine feed chain drum floated up, check clearances: There should be 1 to 2 inches (25 to 50 mm) clearance between adapter drum and combine feed chain drum, while still providing adequate clearance to header backsheet. If repositioning adapter drum does not provide enough clearance both fore and aft, remove one row of tines from drum (2 or 3 tines, depending on drum size).
13. Adjust header flotation to compensate for the shift in weight. See "Header Flotation" in Windrower or Combine Adapter Op. Manual.
14. For rotary combines with narrow feeder opening, increase delivery opening width to be suitable for windrowing. See "Delivery Opening Width", beginning on page 21.

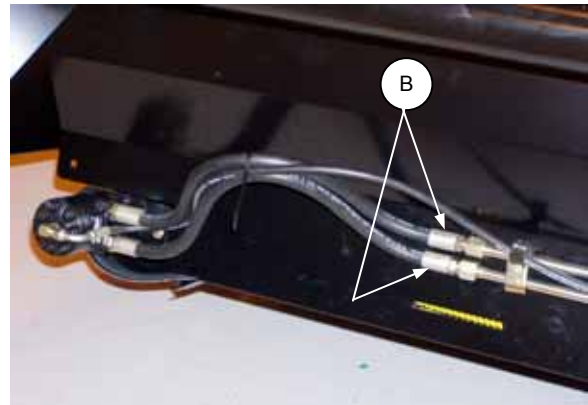

REVERSE HOSES AT HYDRAULIC LINES

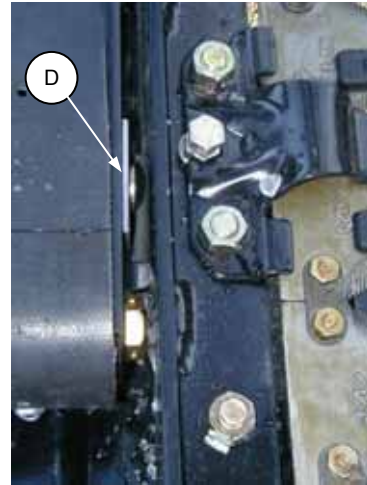

LOOSEN SUPPORT HARDWARE – COMBINE HDR.

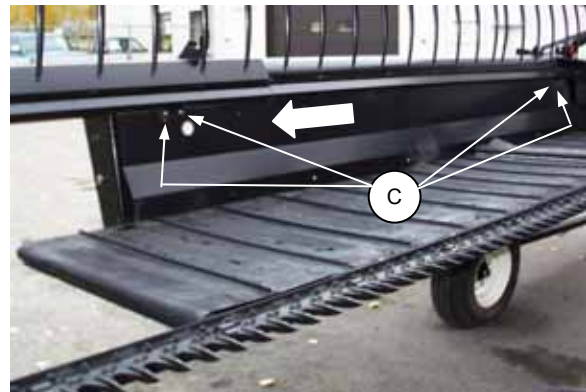

LOOSEN CLAMPS



USE "COME-ALONG" TO MOVE DECK

HEADER OPERATION

Operating Variables (continued)

REEL SPEED

- Reel speed affects the smoothness and evenness of the delivered crop. Operating the reel too fast or too slow relative to ground speed will cause bunching.
- In standing crop, reel speed should be just faster than ground speed, sweeping crop across the sickle.
- A faster reel speed may be necessary in leaning or down crop.
- Excessive shattering of grain heads or crop loss over the header back tube may be indications that reel speed is too fast.

REEL HEIGHT

- In standing crop, adjust reel height so bat contacts the plants just below the head, and carries material through the sickle onto the drapers.
- Down crop may require a lower reel height to wipe crop off the sickle.
- Bushy crop may require raising the reel to prevent unevenness in delivery.
- Indications that reel may be too low are crop loss over the header back tube, or disturbance of crop on the drapers by the reel bats.
- For reel clearance to cutterbar adjustment, see Maintenance/Service section, page 50.

REEL POSITION - FORE & AFT

Reel fore-aft position can be adjusted to suit various crop conditions:

- For straight standing crop, the reel position is normally centered above the cutterbar.
- For crops that are down, tangled, or leaning, move reel ahead of cutterbar.
- Disturbance of crop on the drapers by the reel bats may be an indication that the reel is too far back.

To adjust reel fore-aft position:

1. Lower reel so support arms are horizontal.
2. Back off jam nut on positioning screw (A) at each arm.
3. Loosen screw (A) and slide reel mounting channel (B). Pry bar may be used at hole (C).
4. Tighten screw into selected hole position and secure with jam nut.
5. Be sure screw is in the same hole at each arm.
6. Check reel clearance to cutterbar. See Maintenance/Service section.

NOTE: If reel fore-aft position is changed by more than two holes, check and adjust header flotation.

NOTE: For 36' center arm, positioning screw is on top of mounting channel. (There is no jam nut on positioning screw at center arm.)

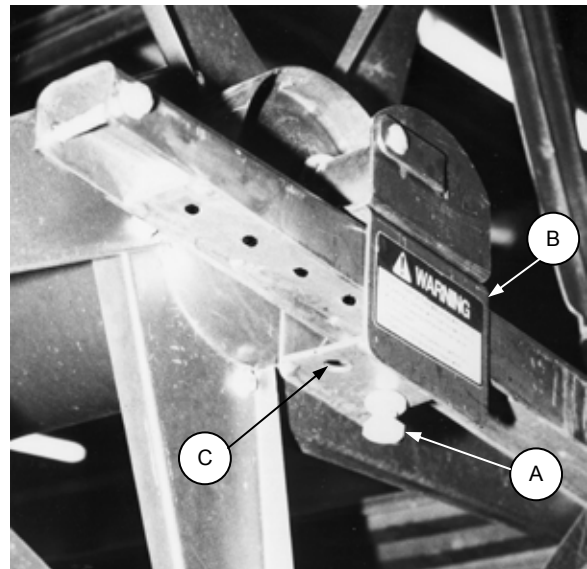

REEL FORE-AFT POSITION ADJUSTMENT

HEADER OPERATION

Operating Variables

DIVIDER ANGLE

The dividers can be angled in or out to provide proper separation and clean entry in a variety of crops. Divider gather is factory set at approximately 1.5 inches (40 mm). In tangled crops like canola, it may be necessary to reduce gather.

To adjust angle, loosen hardware (A), position divider and tighten hardware.

NOTE: On left side, ensure that front hinge pin of side shield remains covered.

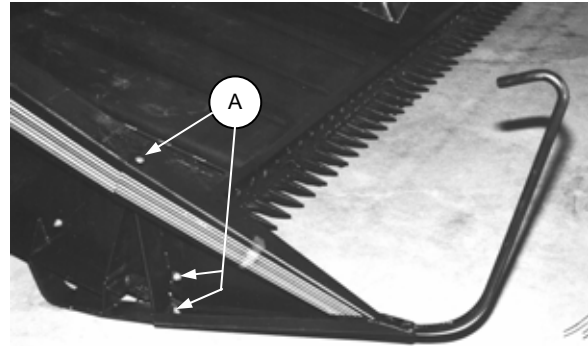

DIVIDER ANGLE ADJUSTMENT

Shut Down Procedure



CAUTION: Before leaving operator's seat for any reason:

1. Park on level ground if possible.
2. Lower the header and reel fully.
3. Place all controls in **NEUTRAL** or **PARK**.
4. Disengage header drive.
5. Engage the park brake.
6. Stop engine and remove key from ignition.
7. Wait for all movement to stop.

HEADER OPERATION

Windrowing

The factors listed below will all affect the formation of the windrow. You will quickly become adept at adjusting these variables to achieve the desired results.

NOTE: Crop condition is a major factor in forming a good windrow. While standing or uniformly leaning crops can generally be easily formed into an acceptable windrow, such is not the case when stalks are tangled or leaning in several directions.

GROUND SPEED

Ground speed should be such that the sickle can cut crop smoothly and cleanly, while giving the desired windrow formation.

Ground speed affects the orientation of stalks in the windrow. Increasing ground speed will cause the configuration of the windrow to go from parallel formation to herringbone or dovetail. See "Windrow Characteristics" in this section.

CUTTING HEIGHT

For grain crops the windrow should normally be laid on stubble from 6 to 8 inches high (150 - 200 mm).

Benefits of a stubble of this height:

- Allows free circulation of air under the windrow for more even drying.
- Supports the windrow without bending.
- Keeps grain heads from contacting ground. Heads that touch the ground are difficult to pick up and will sprout in damp weather.

HEADER ANGLE

Steeper draper angles tend to form herringbone or dovetail configurations, while flatter draper angles form parallel or fantail windrows. See "Windrow Characteristics" in this section.

DRAPER SPEED

Draper speed affects the orientation of stalks in the windrow. Faster draper speeds will tend to form herringbone or dovetail configurations. See "Windrow Characteristics" in this section.

REEL SPEED

Reel speed affects the smoothness and evenness of the windrow. Operating the reel too fast or too slow relative to ground speed will cause bunching.

HEADER OPERATION

Windrowing

DELIVERY OPENING

The width and position of the delivery opening affects the width and configuration of the windrow. The decision to widen or narrow the center delivery opening; or whether or not to double windrow should be based on the following factors:

- combine pick-up capability
- type and yield of crop
- weather conditions (rain humidity, wind)
- drying time available

See "Windrow Characteristics" for the strengths and weaknesses of the various windrow configurations with respect to these factors. See "Delivery Opening Width" under Operating Variables for opening width adjustment procedure.

HEADER OPERATION

Windrowing

WINDROW CHARACTERISTICS

There are three basic criteria by which the quality of a windrow is measured:

1. Weight Distribution - heads and stalks distributed evenly across full width of windrow.
2. Good Curing - a loose, open windrow for better drying.
3. Good Weatherability - a well formed windrow that supports heads off the ground and holds together in extreme weather conditions.

HERRINGBONE WINDROW

The most desirable form of windrow, stalks are crossed and interwoven. Heads are distributed across full width of windrow. This windrow can be formed by center delivery only. Windrow rating:

Weight Distribution: Good
Curing Characteristics: Good
Weatherability: Excellent

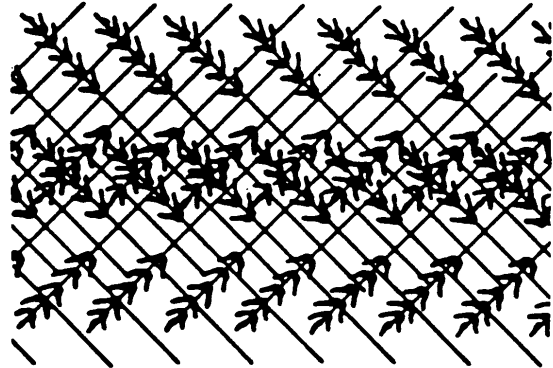

HERRINGBONE WINDROW

FANTAIL WINDROW

The stalk tips are crossed in the center and heads are in line along outside edges. This windrow can be formed by center delivery only. Windrow rating:

Weight Distribution: Fair
Curing Characteristics: Fair
Weatherability: Fair

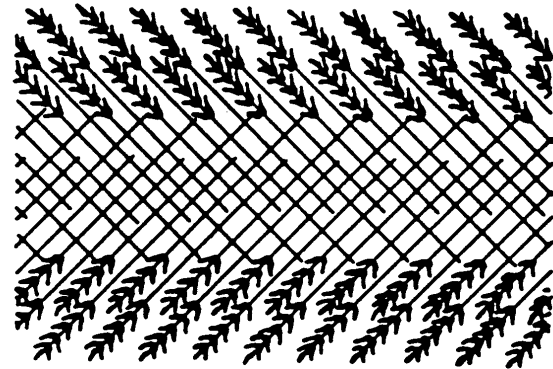

FANTAIL WINDROW

DOVETAIL WINDROW

The stalk tips are lined along outside edges of windrow and heads are crossed in center. This windrow can be formed by center delivery only. Windrow rating:

Weight Distribution: Poor
Curing Characteristics: Fair
Weatherability: Poor

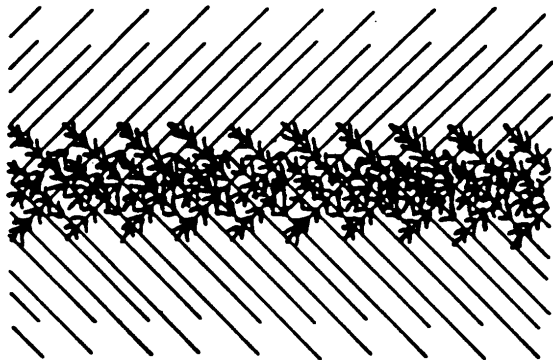

DOVETAIL WINDROW

HEADER OPERATION

Windrowing

WINDROW CHARACTERISTICS (continued)

PARALLEL WINDROW

The stalks are parallel to windrow and heads evenly distributed across width of windrow. This windrow can be formed by center delivery or end delivery. Windrow rating:

Weight Distribution: Good
Curing Characteristics: Good
Weatherability: Good

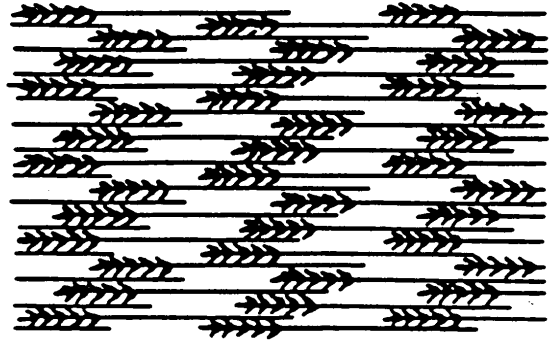

PARALLEL WINDROW

45° DIAGONAL WINDROW

The stalk tips are lined along one edge and heads are along opposite edge, 45° to windrow perpendicular. This windrow can be formed by end delivery only. Windrow rating:

Weight Distribution: Poor
Curing Characteristics: Fair
Weatherability: Poor

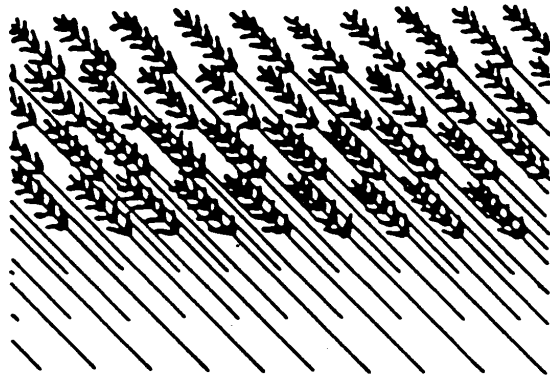

45° DIAGONAL WINDROW

75° DIAGONAL WINDROW

The stalks are closer to parallel than the 45° windrow. Stalk tips are lined along one edge with heads opposite, 75° to windrow perpendicular. This windrow can be formed by end delivery only. Windrow rating:

Weight Distribution: Fair
Curing Characteristics: Good
Weatherability: Fair

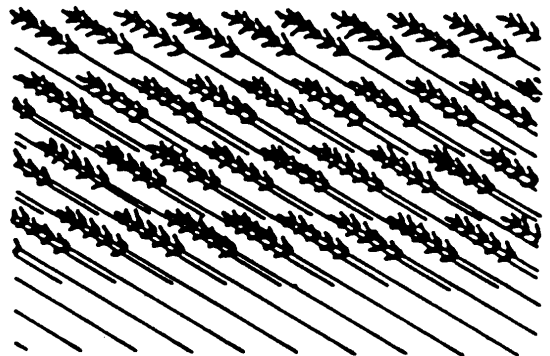

75° DIAGONAL WINDROW

TRANSPORT

Transporting the Header on Windrower or Combine



WARNING: Do not drive windrower or combine with header attached on a road or highway at night, or in conditions which reduce visibility, such as fog or rain. The width of the header may not be apparent under these conditions.



CAUTION:

1. Check local laws for width regulations and lighting or marking requirements before transporting on roads.
2. Follow all recommended procedures in your Windrower or Combine Operator's Manual for transporting, towing etc.
3. Disengage header drive clutch when travelling to and from the field.
4. For headers with gauge wheels, but without transport option, secure gauge wheels in position (A).
5. For headers with transport option: When transporting while attached to windrower or combine, wheels remain in field position. If necessary to raise wheels to clear bridge posts, etc., move to storage position (E). (See NOTE above.) For towing transport, see next page.
6. Before driving windrower or combine on a roadway, be sure flashing amber lamps, red tail lamp and head lamps are clean and working properly. Pivot amber lamps for best visibility by approaching traffic. Always use these lamps on roads to provide adequate warning to other vehicles.
7. Do not use field lamps on roads, other drivers may be confused by them.
8. Before driving on a roadway, clean slow moving vehicle emblem and reflectors. Adjust rear view mirror and clean windows.
9. Lower the reel fully and raise header unless transporting in hills. (See point #10.) Maintain adequate visibility and be alert for roadside obstructions, oncoming traffic and bridges.
10. When travelling down hill, reduce speed and keep header at a minimum height. This provides maximum stability if forward motion is stopped for any reason. Raise header completely at bottom of grade to avoid contacting ground.
11. Travel speed should be such that complete control and machine stability are maintained at all times.

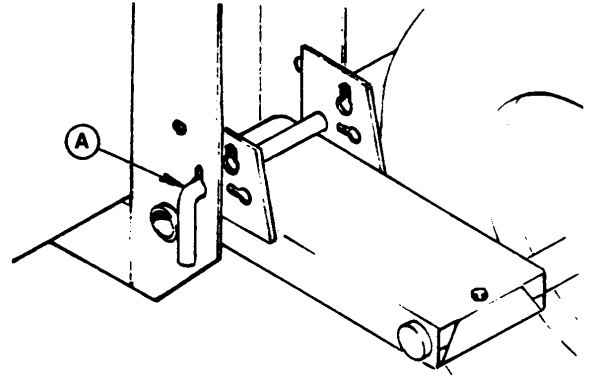

GAUGE WHEELS - TRANSPORT POSITION
(WITHOUT TRANSPORT OPTION)

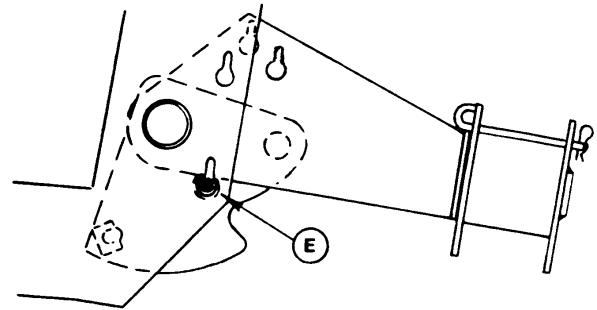

TRANSPORT OPTION GAUGE WHEELS -
STORAGE POSITION (R/H SHOWN)

TRANSPORT

Gauge Wheels / Transport Option

Some 30 and 36 foot headers are equipped with the transport option which allows pivoting the gauge wheels 90° to allow towing the header sideways.

CONVERTING FROM FIELD POSITION TO TRANSPORT

1. Move reel fully back on support arms, unless combine adapter is installed in header*. See "Reel Position - Fore & Aft" for adjustment details. Lower the reel. To prevent damage to reel support arms, do not transport with reel props engaged.

* **IMPORTANT:** If header is being transported with combine adapter installed:

- With pick-up reel – Move reel to a mid-range fore-aft position.
- With bat reel – Move reel further forward.

Always check stability of load before transporting. The wheels on the R/H wheel beam should both be carrying approximately the same weight.

2. If adapter is installed, fully retract center link between header and adapter.

3. Raise header fully.



DANGER: To avoid bodily injury or death from unexpected start-up or fall of raised header, stop engine, remove key and engage header lift cylinder stops before going under header for any reason.

4. If adapter is installed, engage float lockout on combine adapter. See Adapter Operator's Manual.

At R/H end:

5. Remove L-pin (L) at R/H wheel support, lower wheel beam and place L-pin in storage position as shown.

6. · Remove hair pins and bar (D) from field position (in welded plates on beam).

· Rotate wheel beam 90° to position under header as shown.

7. Raise cutterbar support (E) fully. (Top edge of support should be directly beneath guard bolts.)

8. Position head of bar (F) on anchor (G). Install bar (D) (removed in step 6) and secure with two hairpins.

NOTE: Head pivots on bar (F) to allow proper fit in all applications. Do not over-tighten pivot hardware.

Engage latch (H) into notch on bar (F).

At L/H end:

9. Remove L-pin (B) from field position at left wheel support and remove pin (A), allowing caster to lower. Rotate wheel 90° to under side of header.

10. Raise wheel support up to about 45°. Install pin (B) in conversion position as shown (through support and spring plate).

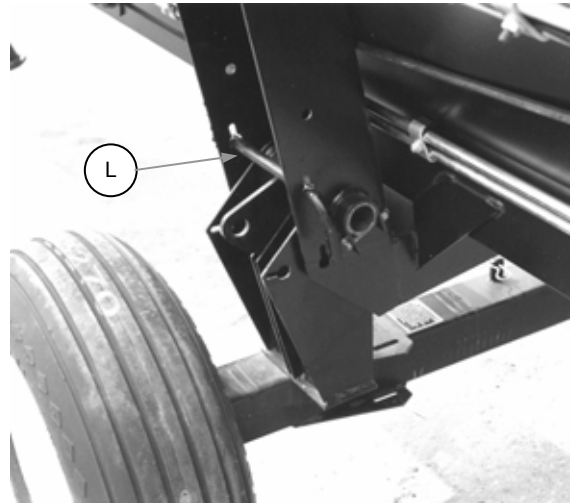

R/H WHEEL BEAM - TRANSPORT POSITION

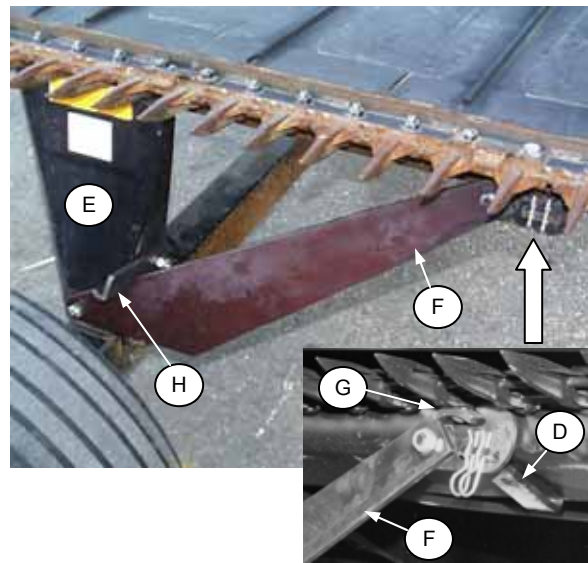

CUTTERBAR SUPPORT

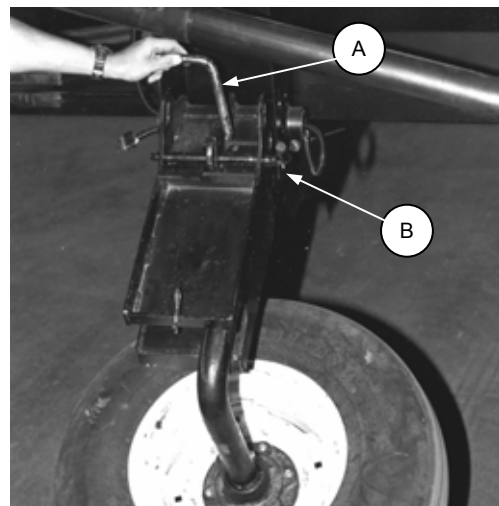

LEFT WHEEL SUPPORT - CONVERSION POSITION

TRANSPORT

Gauge Wheels / Transport Option

CONVERTING FROM FIELD POSITION TO TRANSPORT

At L/H end (continued):

11. Slide bar (C) to caster side of support. (Bar stops caster from sliding up.)
12. Move pin (B) at left wheel support from conversion position to transport position (through header leg as shown).
13. Disengage header lift cylinder stops and slowly lower header until wheels are on the ground. Block the tires to prevent header rolling and to ensure left wheel remains under header, tracking approximately parallel to cutterbar.
14. At right end, check that cutterbar support contacts guards.
15. Detach header from power unit. See Windrower Tractor or Combine Adapter Operator's Manual. Be sure reel is fully down and all hydraulic lines are properly disconnected and stored. If combine adapter is to remain with the header, ensure float lock-outs are engaged.
16. Remove hitch pole from storage on frame tube and place hitch over left wheel caster. Position hitch against stop welded on caster and install pin (A) (removed in step 9) with hairpin.
IMPORTANT: Be sure pin is inserted far enough to allow pin handle to hang down as shown.
17. Attach wiring harness (H) at left caster.

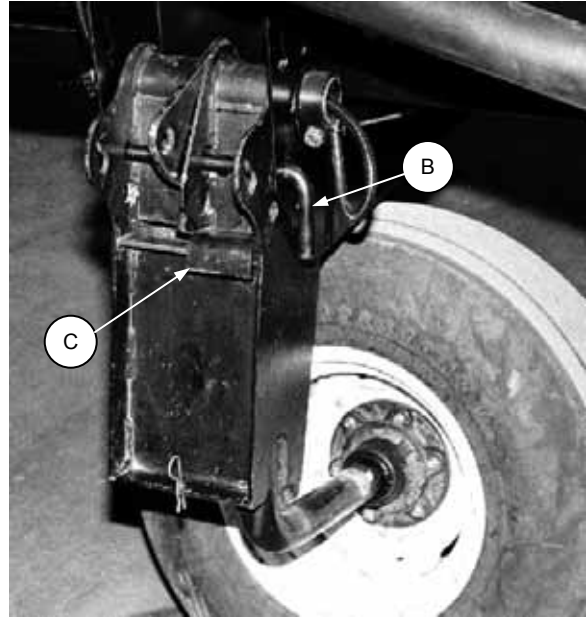

LEFT WHEEL - TRANSPORT POSITION

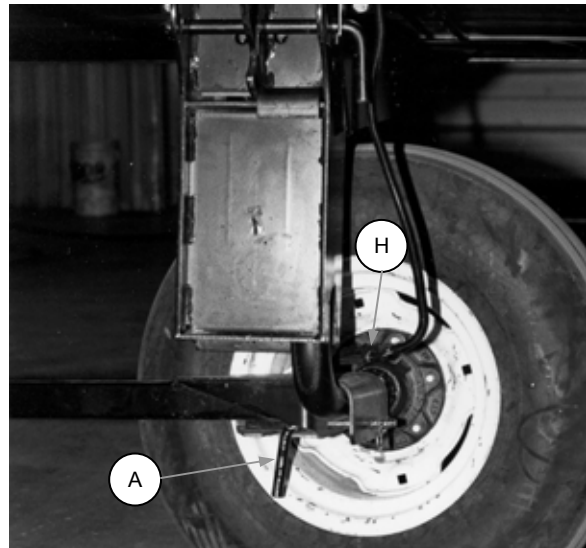

ATTACH HITCH AND WIRING HARNESS

TRANSPORT

Gauge Wheels / Transport Option

ATTACHING TO TOWING VEHICLE



CAUTION: To avoid bodily injury and/or machine damage caused by loss of control:

1. To ensure adequate braking performance and control, do not tow with a vehicle weighing less than 5000 lbs. (2300 kg).
2. To increase header stability in transport, ensure that reel is down and properly positioned on support arms (see page 32, step 1).
3. Check that all pins are properly secured in transport position at wheel supports, hitch and cutterbar support.
4. Check tire condition and pressure prior to transporting.
5. Connect hitch to towing vehicle with a proper hitch pin with a spring locking pin or other suitable fastener.
6. Attach hitch chain to towing vehicle. Adjust chain length to remove all slack except what is needed for turns.
7. Connect header wiring harness 7-pole plug to mating receptacle on towing vehicle. (The 7-pole receptacle is available from your dealer parts department.)
8. Ensure lights are functioning properly, and clean the slow moving vehicle emblem and other reflectors.

TOWING THE HEADER



CAUTION: THIS IS INTENDED AS A LOW SPEED TRANSPORT. To avoid bodily injury and or machine damage caused by loss of control:

1. Do not exceed 20 mph (30 km/h). Reduce transport speed for slippery or rough conditions.
2. Turn corners only at very low speeds [5 mph (8 km/h) or less]. While cornering, header stability is reduced as front wheel moves to the left.
3. Obey all highway traffic regulations in your area when transporting on public roads. Use flashing amber lights unless prohibited by law.

NOTE: There are two holes in cutterbar support (E) for attaching bar (F). If rear wheels are misaligned, causing header to tow at an angle, move hardware to alternate position (G) or (H). (Hardware is shown "ghosted" at (H) for illustration purposes.) Latch (J) will then align with second notch in bar (F).

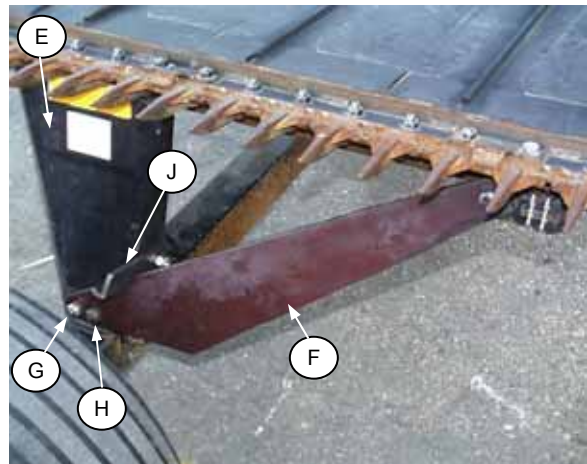

CHOOSE POSITION FOR BEST ALIGNMENT

TRANSPORTING ON A TRAILER

IMPORTANT: When trailer transporting a header equipped with the transport option, support the long end of R/H wheel beam. Failure to do so may result in damage to transport components.

TRANSPORT

Gauge Wheels / Transport Option

CONVERTING FROM TRANSPORT TO FIELD POSITION

1. Block the tires to prevent header rolling. Be sure left wheel is straight (tracking parallel to cutterbar).
2. Remove pin securing hitch to left wheel caster, and detach wiring harness at 4-way connector. (Store header section plug inside wheel support tube.) Remove hitch and store on frame tube as follows: Place drawbar end of hitch over hardware at (J) and secure with hairpin. Rest other end of hitch in support at (K).

NOTE: Secure hitch chain to prevent rubbing on back tube.

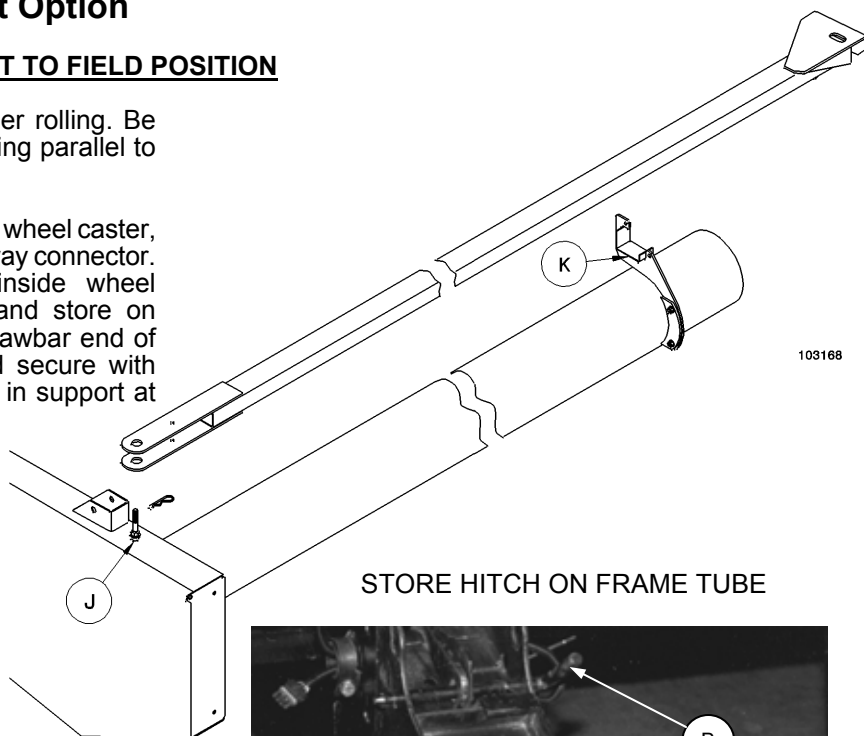

STORE HITCH ON FRAME TUBE

3. Attach header to power unit. See Windrower Tractor or Combine Adapter Operator Manual.
4. Raise header fully.



DANGER: To avoid bodily injury or death from unexpected start-up or fall of raised header, stop engine, remove key and engage header lift cylinder stops before going under header for any reason.

5. At left wheel support, remove pin (B) from transport position and raise wheel support up to about 45°. Install pin (B) in conversion position through support and spring plate as shown.
6. Slide bar (C) to other side of support.
7. Rotate left wheel caster 90° to field position and push caster fully up to engage slot in wheel support. Install pin (A) (removed from hitch in step 2) to hold caster up. Store hairpin in bottom flange of support.
8. Move pin (B) at left wheel support from conversion position to one of two field positions. (See "Gauge Wheel Field Positions" on page 18.) This also locks pin (A) in field position.

NOTE: Left wheel caster can be installed at left or right side of wheel support. This positions the left wheel inboard or outboard of wheel support as desired. See Assembly section, page 67 for installation details.

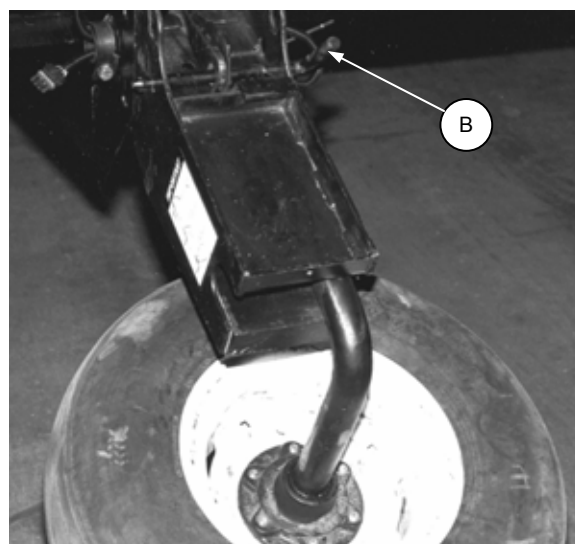

LEFT WHEEL - CONVERSION POSITION

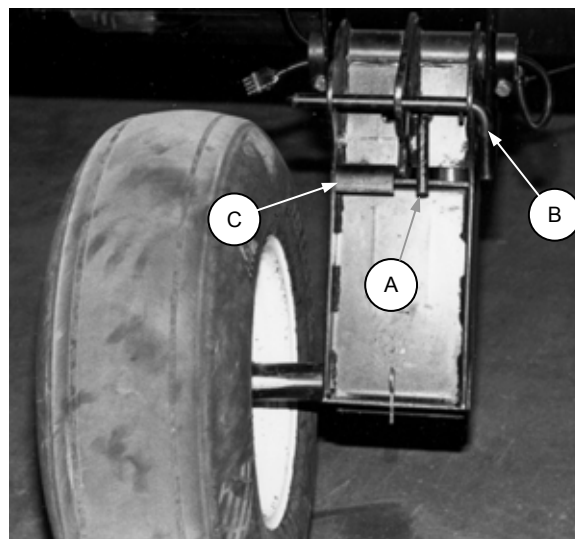

LEFT WHEEL - FIELD POSITION

TRANSPORT

Gauge Wheels / Transport Option

CONVERTING FROM TRANSPORT TO FIELD POSITION (continued)

9. At right hand dual wheel assembly:
 - Remove hairpins and bars (F) and (D) from transport position at cutterbar anchor.
 - Lower cutterbar support (E) and rotate bar (F) to storage position shown. Secure with hairpin.
10. Rotate wheel beam 90°, moving wheel from under cutterbar to field position.
NOTE: The pivot shaft on the right wheel beam can be installed at right or left side of wheel support. This allows field positioning of the beam either "inboard" (towards center of header) or "outboard" (towards end of header). See Assembly section, page 66 for installation details.
11. Install bar (D) and two hair pins in field position shown, contacting edge of support (J). This prevents beam from swinging under raised header in field position.
12. Raise beam and install L-pin (L) in one of two field positions. (See "Gauge Wheel Field Positions" on page 18.)
13. Disengage float lockout on combine adapter. If installed, and extend center link to desired operating position.
14. Lower header to cutting height and move reel to desired operating position.

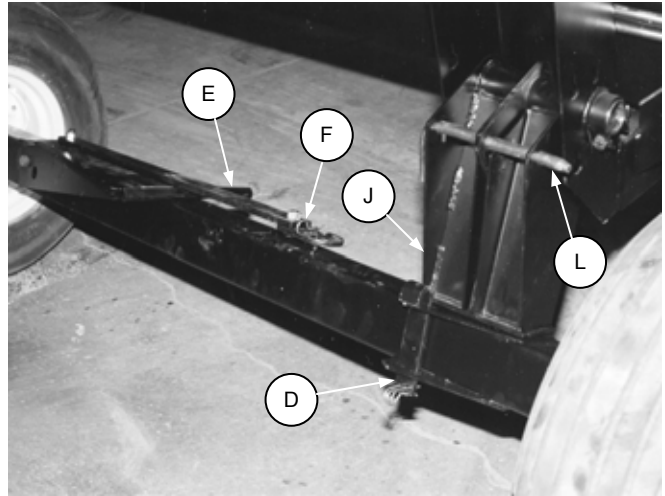

R/H WHEELS - FIELD POSITION
(INBOARD POSITION SHOWN)

Storage Procedure

Do the following at the end of each operating season:

1. Clean the header thoroughly.



CAUTION: Never use gasoline, naphtha or any volatile material for cleaning purposes. These materials may be toxic and/or flammable.

2. **Cover cutterbar and sickle guards to prevent injury from accidental contact.**

Also:

3. Store machine in a dry protected place if possible. If machine is stored outside, cover with a waterproof canvas or other protective material.
4. If machine is stored outside, remove drapers and store in a dark, dry place.
NOTE: If drapers are not removed, store header with cutterbar lowered so water/snow will not accumulate on drapers. This accumulation of weight puts excessive stress on drapers and header.
5. Lower header onto blocks to keep cutterbar off the ground.
6. Lower reel completely. If stored outside, tie reel to frame to prevent rotation caused by wind.
7. Repaint all worn or chipped painted surfaces to prevent rust.
8. Lubricate the machine thoroughly, leaving excess grease on fittings to keep moisture out of bearings. Oil cutterbar and apply grease to exposed threads and sliding surfaces of components.
9. Check for worn or broken components and repair or order replacements from your dealer. Attention to these items right away will save time and effort at beginning of next season.
10. Replace or tighten any missing or loose hardware. See Specifications section, page 10 for torque charts.

MAINTENANCE/SERVICE

SERVICE PROCEDURES



CAUTION: To avoid personal injury, before servicing machine or opening drive covers:

1. Fully lower header and reel. If it is necessary to service in the raised position, first engage header lift cylinder stops and reel props.
2. Disengage header drive clutch.
3. Stop engine and remove key.
4. Engage park brake.
5. Wait for all moving parts to stop.

Park on level surface when possible. Block wheels securely. Follow all recommendations in your Windrower or Combine Operator's Manual.

Wear close-fitting clothing and cover long hair. Never wear dangling items such as scarves or bracelets.

Wear protective shoes with slip resistant soles, a hard hat, protective glasses or goggles and heavy gloves.

If more than one person is servicing the machine at the same time, be aware that rotating the driveline by hand (for example to access a lube fitting) will cause other drive components (belts, pulleys and sickle) to move. Stay clear of driven components at all times.

Be prepared if an accident should occur. Know where the first aid kit and fire extinguisher are located and how to use them.

Keep the service area clean and dry. Wet or oily floors are slippery. Wet spots can be dangerous when working with electrical equipment. Be sure all electrical outlets and tools are properly grounded.

Use adequate light for the job at hand.

Replace all shields removed or opened for service.

NOTE: The left-hand drive shield, in the open position, rests on bracket (A) to prevent it from falling.

To close drive shield, push bracket (A) to free the welded bolt to travel in bracket slot.

To open shield, pull catch handle (along bottom edge of end sheet) towards you.

Use only service and repair parts made or approved by the equipment manufacturer. Substituted parts may not meet strength, design or safety requirements.

Keep the header clean. Never use gasoline, naphtha or any volatile material for cleaning purposes. These materials may be toxic and/or flammable.

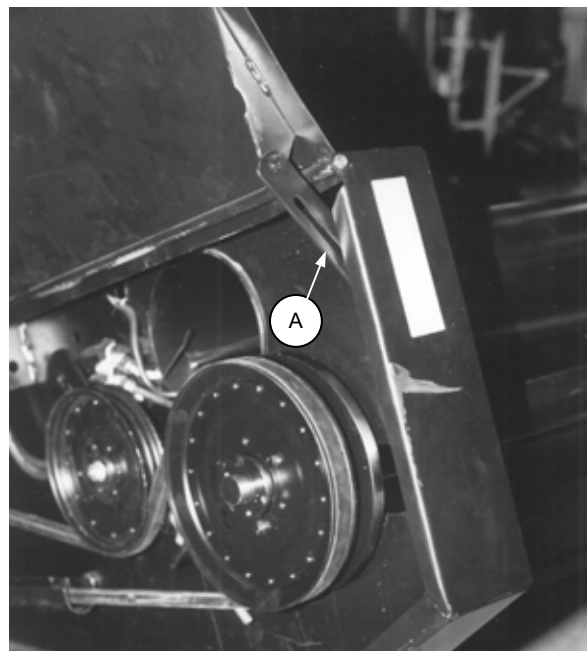

L/H DRIVE SHIELD

MAINTENANCE/SERVICE

RECOMMENDED LUBRICANTS

GREASE

Use an SAE Multi-Purpose High Temperature Grease with Extreme Pressure (EP2) Performance and containing a maximum of 1% moly (molybdenum disulphide).

For driveline slip-joints only, increased moly content (up to 10%) is recommended. **IMPORTANT:** Do not use this higher moly content grease on bearings, as it may cause excessive wear in high speed applications.

WOBBLE BOX LUBRICANT

In sickle drive wobble box, use SAE 85W-140 gear lubricant. (API Service Classification GL-5)

CAPACITIES: Wobble Box - 2.2 L (2.3 U.S. quarts)

STORING AND HANDLING LUBRICANTS

Your machine can operate at top efficiency only if clean lubricants are used. Contaminant in lubricants is the most likely cause of bearing and hydraulic system failure. Use clean containers to handle all lubricants. Store lubricants in an area protected from dust, moisture and other contaminants. Keep hydraulic couplers and connectors clean.

SEALED BEARING INSTALLATION

1. Clean shaft and coat with rust preventative.
2. Install flangette, bearing, flangette and lock collar. The locking cam is only on one side of the bearing.
3. Install and tighten the flangette bolts.
4. When the shaft is located correctly, lock the lock collar with a punch. The collar should be locked in the same direction the shaft rotates. Tighten the setscrew in the collar.
5. Loosen the flangette bolts on the mating bearing one turn and re-tighten. This will allow the bearing to line up.

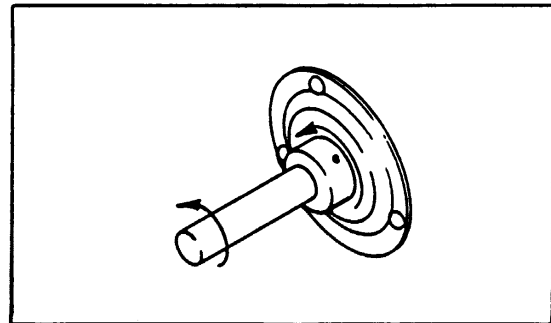

TIGHTEN COLLAR IN DIRECTION
SHAFT ROTATES

MAINTENANCE/SERVICE

GREASING THE HEADER

See "Recommended Lubricants" in this section for recommended greases.

The following greasing points are marked on the header by decals showing a grease gun (A), and grease interval (B) in hours of operation. Use the hour meter in the windrower or combine cab and the "Maintenance Checklist" provided to keep a record of scheduled maintenance.

Procedure:

1. Wipe grease fitting with a clean cloth before greasing, to avoid injecting dirt and grit.
2. Inject grease through fitting with grease gun until grease overflows fitting.
3. Leave excess grease on fitting to keep out dirt.
4. Replace any loose or broken fittings immediately.
5. If fitting will not take grease, remove and clean thoroughly. Also clean lubricant passageway. Replace fitting if necessary.



DANGER: Stay clear of driveline until all movement has stopped. Entanglement with rotating driveline will cause serious personal injury or death. Avoid loose fitting or dangling clothing.

10 Hours or Daily

1. Secondary Driveline (D) - three fittings

NOTE: To open driveline shield at header, pry up with screwdriver as shown to release bolt head from welded tab.

NOTE: For windrower, there are two additional 10 Hour fittings at driveline connector shaft.



REMOVING DRIVELINE SHIELD

25 Hours

1. Sickle Head (E) - one fitting

NOTE: If more than 6 to 8 pumps of the grease gun are required to fill the cavity, replace the seal in the sickle head. When changing seal, check pin and needle bearing for wear. Replace if necessary. See page 45

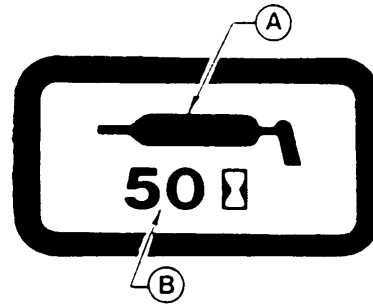

SAMPLE GREASE DECAL



STAY CLEAR OF ROTATING DRIVELINE

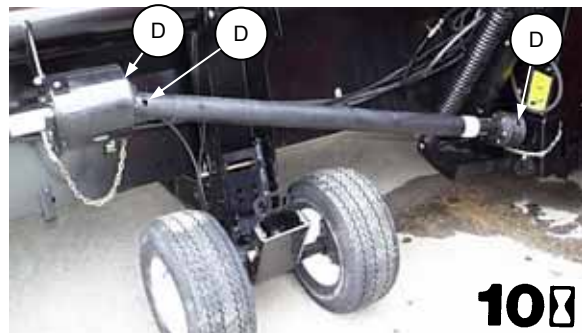

DRIVELINE

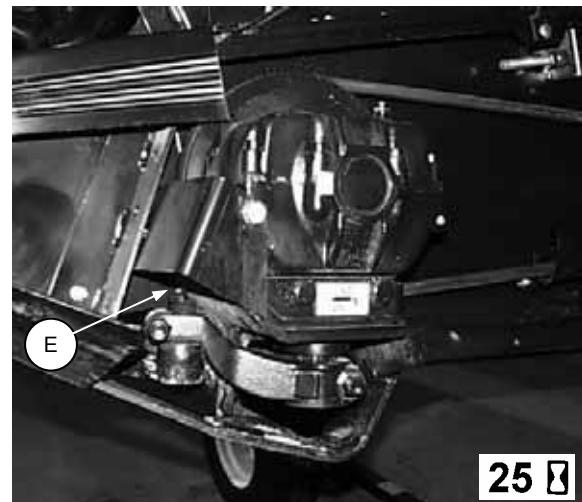

SICKLE HEAD

MAINTENANCE/SERVICE

GREASING THE HEADER (continued)

50 Hours

1. Reel Support Bushing (F) - one fitting (two on 36 ft.)

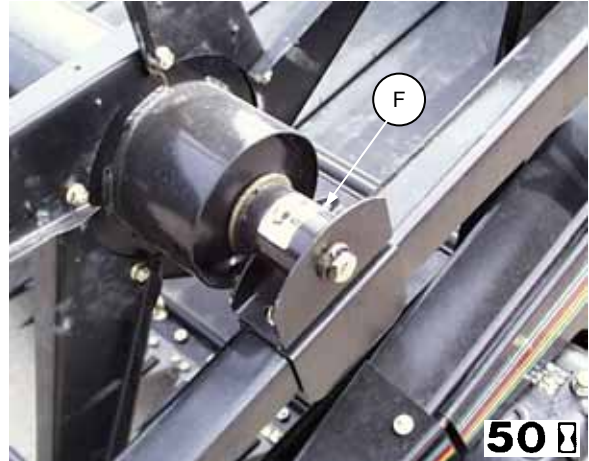

REEL SUPPORT BUSHING

100 Hours or Annually

1. Sickle Drive Shaft Support Bearings (C) - two fittings

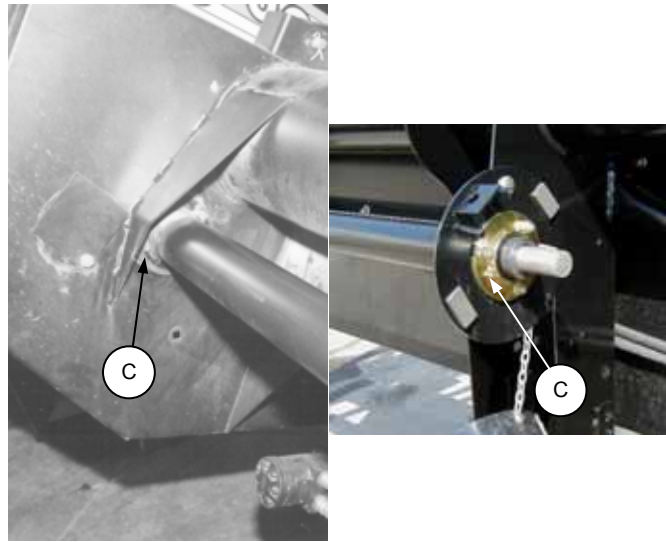

SICKLE DRIVE SHAFT SUPPORT BEARINGS

2. Gauge Wheel Pivot Bushings (H) - one fitting

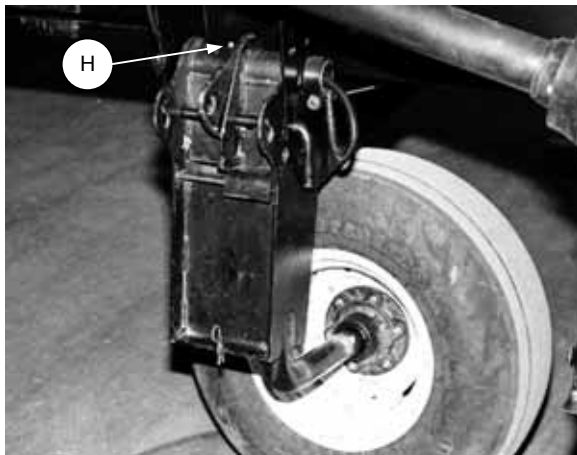

GAUGE WHEEL PIVOT BUSHINGS

3. Split Reel Connector Block (N) - one fitting on 36' headers

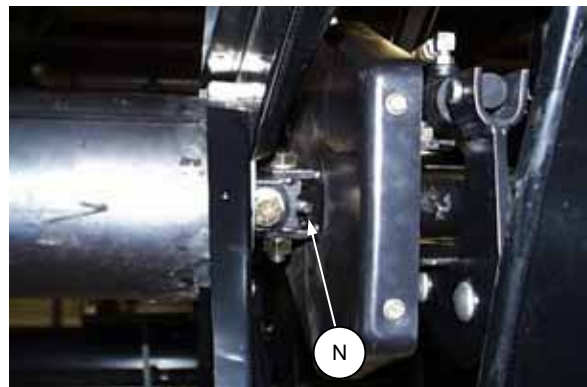

SPLIT REEL CONNECTOR - 36'

MAINTENANCE/SERVICE

GREASING THE HEADER (continued)

500 Hours or Annually

1. Gauge Wheel Hub Bearings (G) - one fitting per wheel

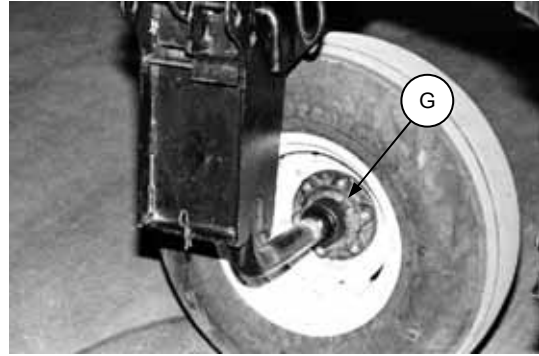

GAUGE WHEEL HUB BEARINGS

HYDRAULIC SYSTEM

Hydraulic Hoses and Lines

Check hydraulic hoses and lines daily for signs of leaks.



WARNING: Avoid high-pressure fluids. Escaping fluid can penetrate the skin causing serious injury. Relieve pressure before disconnecting hydraulic lines. Tighten all connections before applying pressure. Keep hands and body away from pin-holes and nozzles which eject fluids under high pressure. Use a piece of cardboard or paper to search for leaks. IF ANY fluid is injected into the skin, it must be surgically removed within a few hours by a doctor familiar with this type of injury or gangrene may result.

IMPORTANT:

- Ensure all hydraulic couplings are fully engaged before operating header.
- Keep hydraulic coupler tips and connectors clean. Dust, dirt, water and foreign material are the major causes of damage to the hydraulic system.
- To prevent improper mixing of oils: If header is to be switched back and forth from combine to windrower, change oil in Windrower Tractor (or Bi-Directional Tractor) hydraulic system to match Combine hydraulic system. See your Tractor and Combine Operator's Manuals for total hydraulic system care.



AVOID HIGH-PRESSURE FLUIDS



CHECK PROPERLY FOR LEAKS

MAINTENANCE/SERVICE

HYDRAULIC SYSTEM (continued)

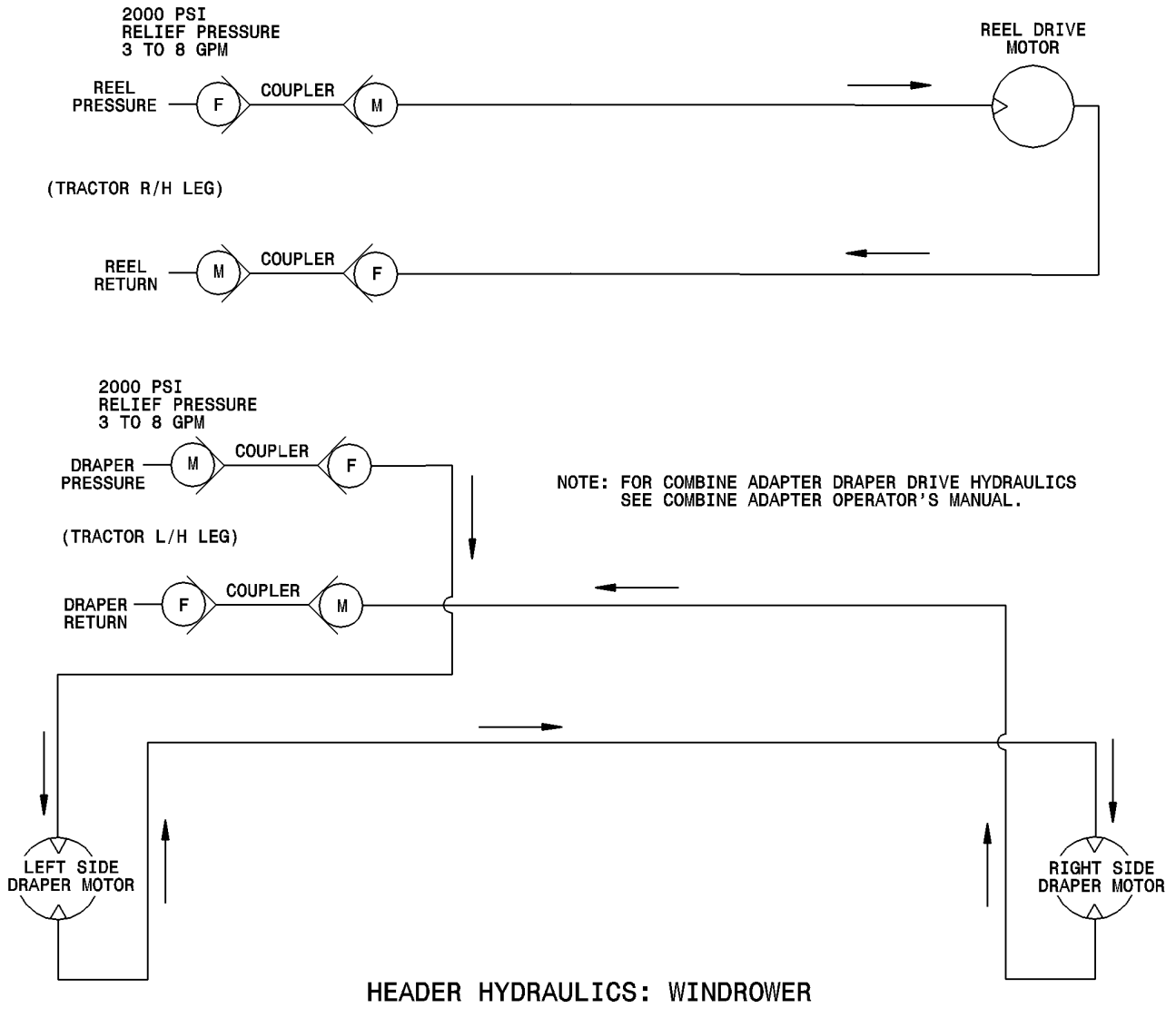

ELECTRICAL SCHEMATIC

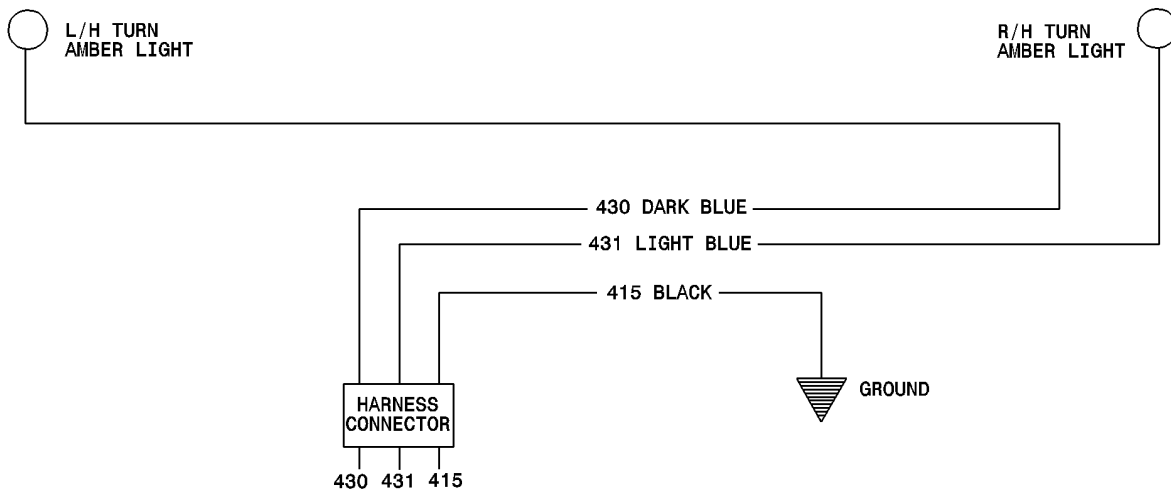

101413

MAINTENANCE/SERVICE

SICKLE AND SICKLE DRIVE



WARNING: Keep hands clear of the area between guards and sickle at all times.



CAUTION: Wear heavy gloves when working around or handling sharp knives.

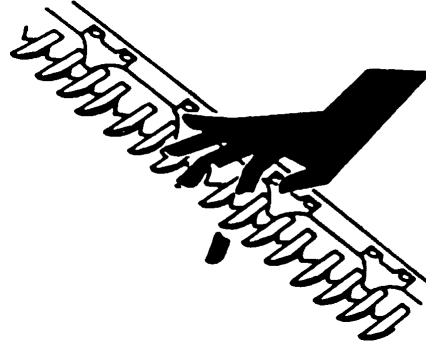

KEEP HANDS AWAY FROM SICKLE

Sickle Lubrication

Apply SAE 10 or equivalent light weight oil daily (one or two drops per section) along entire length of sickle.

NOTE: Do not oil sickle if operating in sandy conditions. Oil will cause sand to adhere to sickle components, resulting in excessive wear.

In some crops, like flax, it may be necessary to wash off the gum that adheres to the sickle with diesel fuel or water.

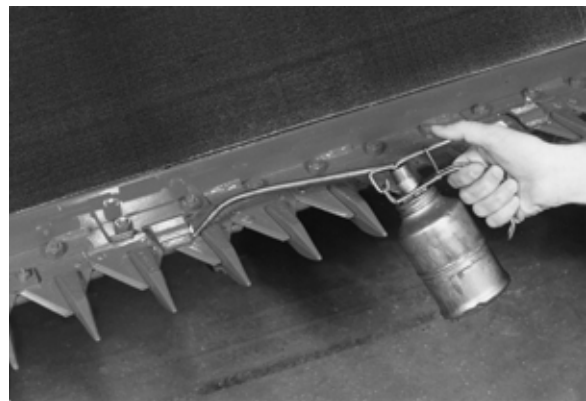

OIL SICKLE DAILY EXCEPT
IN SANDY SOIL

MAINTENANCE/SERVICE

SICKLE AND SICKLE DRIVE (continued)

Sickle Sections

Check daily that sections are firmly bolted to the sickle back and are not worn or broken. Replace as required.

To replace sickle section:

1. A worn or broken sickle section (A) can be replaced without removing sickle from cutterbar.
2. Remove lock nuts and lift section off of bolts.

IMPORTANT: Do not mix heavy and light sickle sections on same sickle.

3. Clean any dirt off of sickle back and position new sickle section on bolts. Secure with lock nuts.

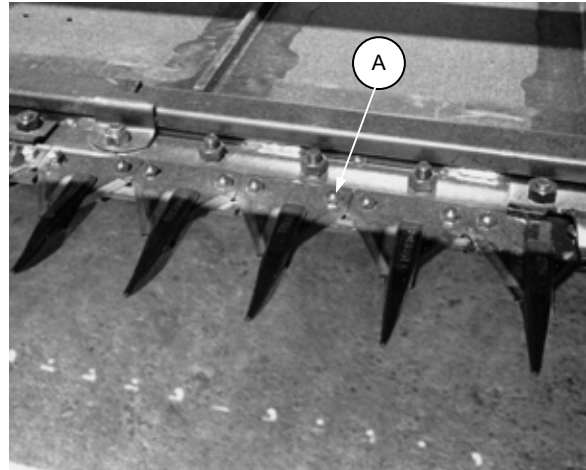

BOLT-ON SECTIONS

To Remove Sickle



WARNING: Always stand to rear and grasp rear edge of sickle during removal to reduce risk of injury from cutting edges. Wear heavy gloves when handling sickle.

1. Clean area around sickle head. Stroke sickle to its outer limit and remove bolt (A).
2. Insert screwdriver in slot (B) and pry up on sickle head pin to free sickle.
NOTE: For ease of disassembly, remove grease fitting from pin to release vacuum.
3. Stroke pitman arm to clear bearing in sickle head. Insert sickle head pin in sickle head to shield bearing from dirt and replace grease fitting if removed.
4. Wrap a chain around sickle head and pull sickle out.

NOTE: For two-piece sickles, remove bolts from splice plate and pull sickle out from both ends.

5. If sickle is not being immediately reinstalled, cover sickle head to shield bearing from dirt.

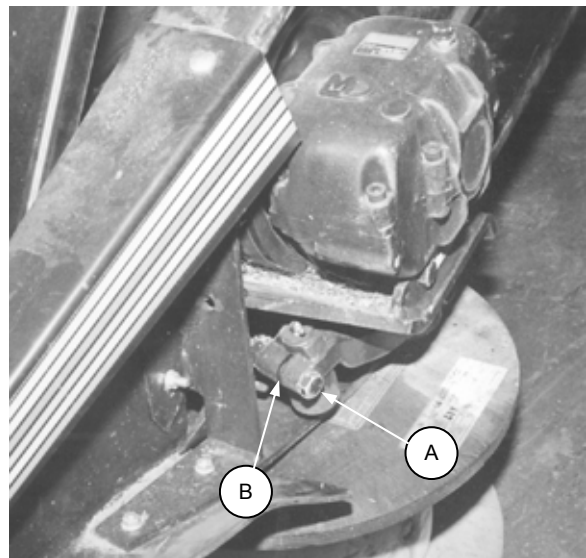

REMOVING SICKLE
(Shield removed for photo clarity)

MAINTENANCE/SERVICE

SICKLE AND SICKLE DRIVE (continued)

Sickle Head Needle Bearing Installation

Using a flat-ended tool (A) with approximately the same diameter as the bearing, push the bearing into the sickle head until the top of the bearing is flush with the step (B) in sickle head.

IMPORTANT: O-ring and plug must be in place in sickle head before installing bearing. Assemble the bearing with the stamped end (the end with identification markings) against the tool.

Install seal (C) in top of sickle head *with lip facing outwards*.

IMPORTANT: To avoid premature sickle head or wobble box failure, be sure there is no looseness in:

- Fit of sickle head pin and needle bearing.
- Fit of sickle head pin and pitman arm.

To Install Sickle



WARNING: Always stand to rear and grasp rear edge of sickle during installation to reduce risk of injury from cutting edges. Wear heavy gloves when handling sickle.

IMPORTANT: Always align guards and re-set sickle hold-downs while replacing sickle.

- Slide sickle into place and replace bolt (D).
NOTE: When installing sickle head pin (E), bottom out the pin in sickle head, then hammer sickle head back up to pitman arm.
- Tighten bolt (D) to 160 ft.lbs. (220 N.m)

Spare Sickle Storage

Provision has been made for storage of a spare sickle in the header main tube, with access from the R/H side.

- From R/H end of header, insert sickle complete with head into plastic sheath in header main tube. Sickle sections point rearward.
- Push sickle into sheath until head (F) contacts stop. Tighten hardware as shown to secure the sickle.

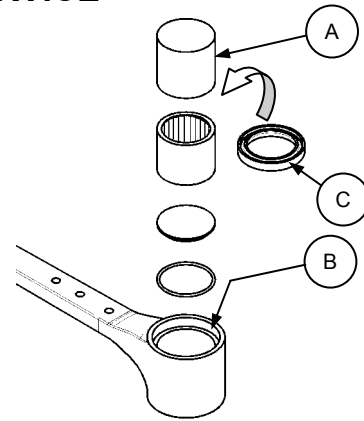

NEEDLE BEARING INSTALLATION

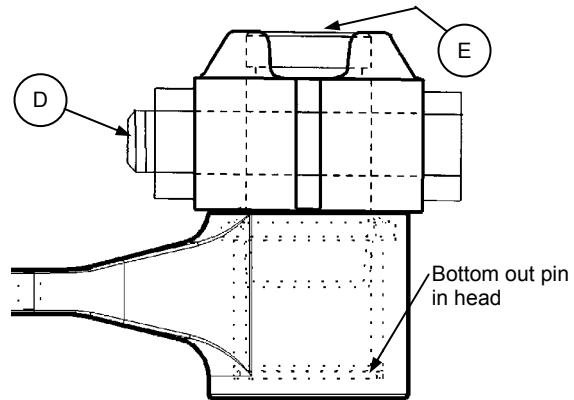

INSTALLING SICKLE – FRONT VIEW

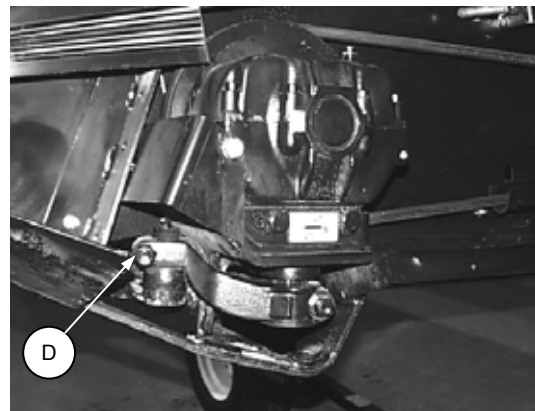

INSTALLING SICKLE

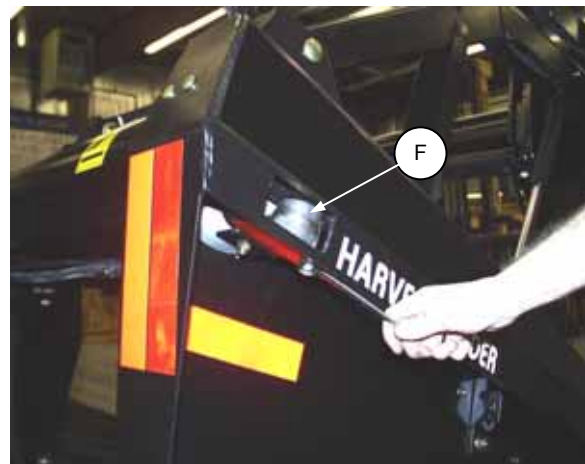

SPARE SICKLE STORAGE

MAINTENANCE/SERVICE

SICKLE AND SICKLE DRIVE (continued)

Guards



CAUTION: Always engage reel props before working under reel.

Check daily that guards are aligned to obtain proper shear cut between sickle section and guard. Sickle sections should contact shear surface of each guard.

Align guards with guard straightening tool (available from your Dealer Parts Department) as shown:

To bend guard tips up, position tool as shown at (A) and pull up.

To bend tips down, position tool as at (B) and push down.

TIP: If trouble is encountered cutting tangled, but easy to cut material (canola, peas, grain) replace guards with stub guards and install a sickle hold-down on every guard. If material is tough to cut, install stub guards with top guard and adjuster plate from the MacDon 932 "Grass Seed Special" Header. See your MacDon dealer.

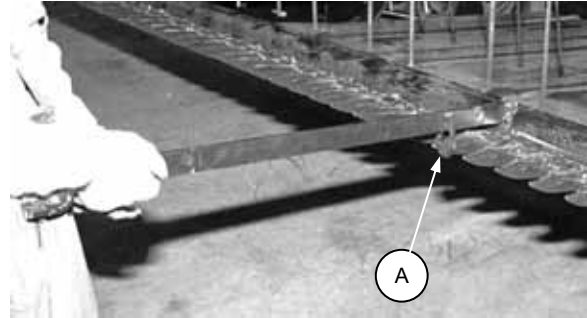

BENDING GUARD TIPS UP



BENDING GUARD TIPS DOWN

Sickle Hold-Downs



CAUTION: Always engage reel props before working under reel.

Check daily that sickle hold-downs are set to prevent sickle sections from lifting off guards but still permit sickle to slide without binding. Set hold-downs after guards are aligned.

To adjust hold-downs:

1. Loosen guard bolts.
2. Using a feeler gauge between hold-down and sickle section, turn bolt (A) to obtain 0.020 inch (0.5 mm) clearance.
3. Tighten guard bolts.
4. After adjusting all sickle hold-downs, run header at a low engine speed and listen for noise due to insufficient clearance. Re-adjust as necessary.

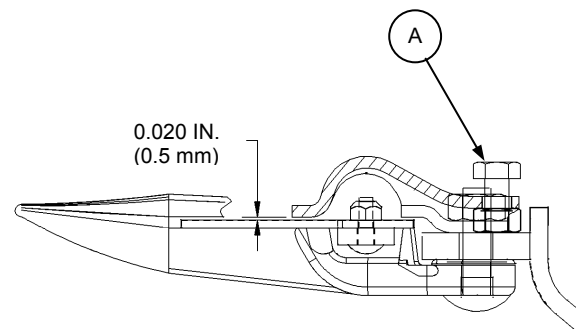

SETTING SICKLE HOLD-DOWNS

MAINTENANCE/SERVICE

SICKLE AND SICKLE DRIVE (continued)

NOTE: The sickle drive assembly at the left end of the header varies depending on the application (windrower or combine). For instructions to convert from one drive configuration to the other, see Assembly section at the back of this book.

Sickle Drive Belt Tension

Check sickle drive belt tension after the first 5 hours operation and every 100 hours thereafter.

IMPORTANT: To prolong belt and drive life, do not over-tighten belt. Operate at minimum tension required to prevent slipping or excessive belt whip. When installing a new belt, never pry belt over pulley. Loosen adjusting device sufficiently to allow easy installation.

To adjust:

1. Loosen nut (A).
2. Turn nut (B) to move idler pulley up or down (depending on drive configuration) to tighten belt until a force of 18 lbs. (80 N) deflects belt 3/4 inch (20 mm) at mid-span.
3. Tighten nut (A).

NOTE: To remove belt, back off idler pulley and remove bolt-on panel in left end sheet at wobble box. Turn belt on edge and work it up and over pulley hub as shown.

Wobble Box Mounting Bolts

Tighten the four wobble box mounting bolts (C) after the first 10 hours operation and every 100 hours thereafter. Torque to 200 ft.lbs. (270 N-m), starting with the side mounting bolts.

Wobble Box Lubricant

Check wobble box lubricant level before first operation and every 100 hours thereafter.

To check:

1. Raise header to a point where the wobble box base is approximately level.
2. Remove breather/dipstick (D). Oil level must be between end of dipstick and bottom hole (or groove) in dipstick.
3. Add as required.

Change wobble box lubricant after first 50 hours operation and every 1000 hours or 3 years thereafter.

To drain wobble box, raise header fully and engage header lift cylinder stops. Remove breather/dipstick (D) and drain plug (E).

Use SAE 85W-140 gear lubricant (API Service Classification GL-5). Capacity of box is 2.2 litres (2.3 U.S. quarts)

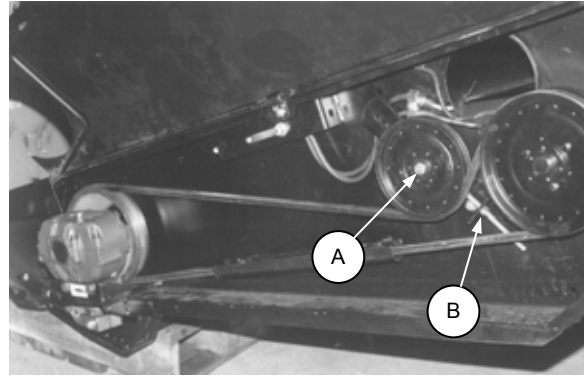

SICKLE DRIVE BELT TENSION - SHOWN IN COMBINE CONFIGURATION

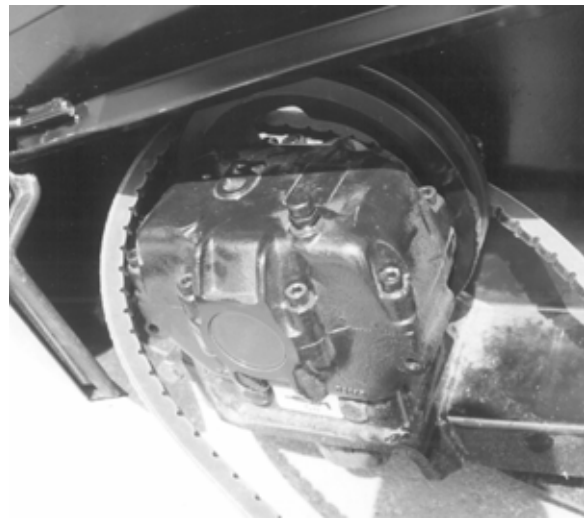

REMOVING SICKLE DRIVE BELT

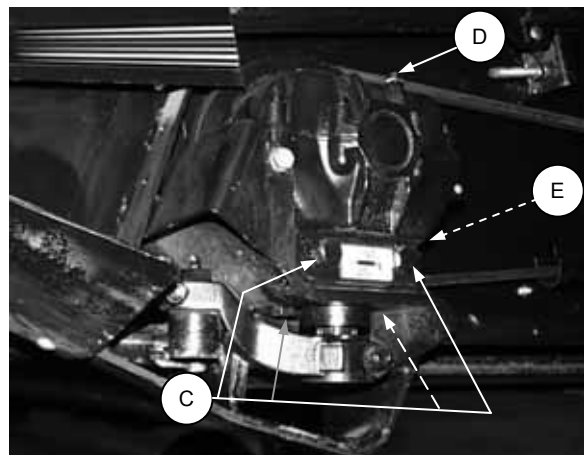

WOBBLE BOX

MAINTENANCE/SERVICE

Wobble Box Assembly/Disassembly

When reinstalling drive arm or pulley:

1. Remove any rust or paint from inner spline. For replacement parts, remove oil/grease with degreasing agent.
2. Before assembly, apply Loctite® #243 adhesive (or equivalent) to spline. Apply in two bands (C) as shown, with one band at end of spline and one band approximately mid-way.

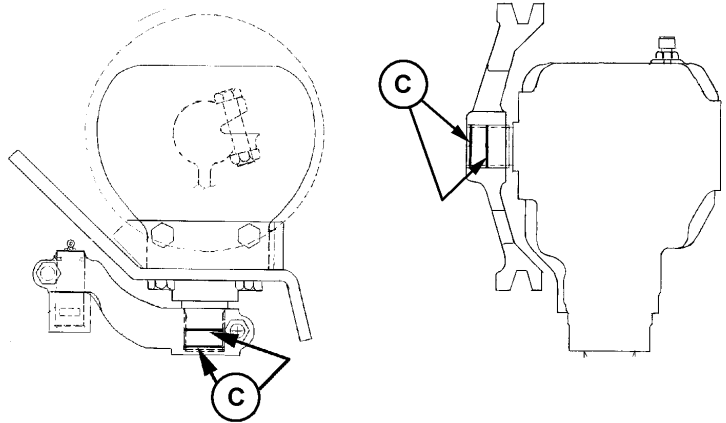

DRAPERS

Draper Tension Adjustment

Draper tension should be just enough to prevent slipping.

Spring assemblies at each outboard roller control draper tension. Set draper tension as follows:

1. Check that draper guide (A) is properly engaged in grooves of both drive and idler rollers.
2. Loosen locknut (B) and slide bracket (C) away from outboard roller as far as hand force allows.
NOTE: It may be necessary to tap bracket (C) with a hammer to start it moving.
3. Tighten locknut (B) to secure the new position.
4. Turn bolt head (D) clockwise until gap (E) between idler spring coils is 1/16 inch (1.5 mm).

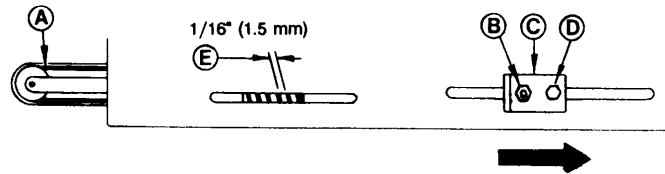

IMPORTANT: Do not over-tighten draper so that spring is completely collapsed (no gap between coils). Operating with spring collapsed may lead to failure of draper, draper rollers and/or tightener components.

Replacing Drapers

When installing drapers:

1. Ensure you have the proper length draper.
2. Adjust draper opening. See page 22.
3. Install screws (C) with heads facing center opening.

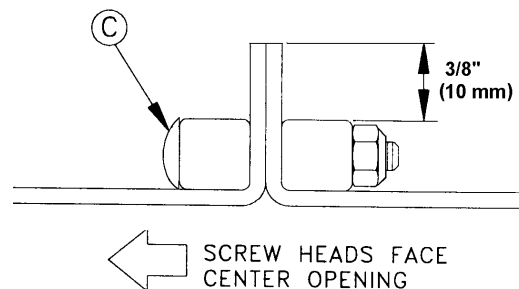

Moving Draper Motors

Draper drive motors may be moved from outboard to inboard and vice versa. The inboard configuration provides more conveying torque in heavy crops and is for windrowing applications only. The maximum delivery opening is recommended with motors inboard.

In combine applications motors must be in outboard configuration because of interference with adapter conveyors.

For instructions on moving draper motors, see "Assembly" section, page 76.

MAINTENANCE/SERVICE

DRAPERS (continued)

Draper Drive & Idler Rollers

Replace draper roller bearings every 500 hours or annually.

NOTE: When tightening jam nuts at ends of idler roller, torque to 30 - 45 ft.lbs. (40 - 60 N-m). Over-tightening may cause thread to fail.

NOTE: At drive roller to motor connection, there is a short "through-bore" setscrew (F) on top of setscrew (G). When removing, be sure to engage Allan wrench only far enough to remove setscrew (F) first, then setscrew (G).

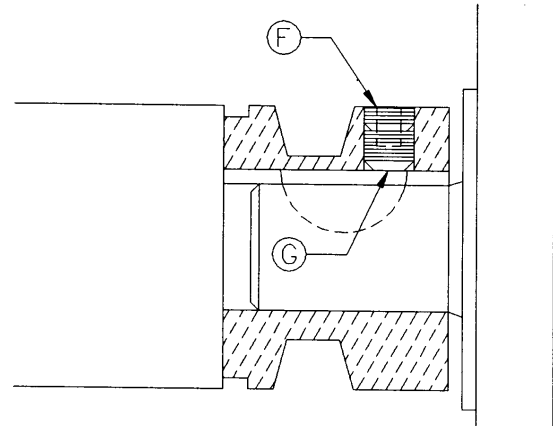

DRIVE ROLLER TO MOTOR CONNECTION

Installation of Draper Seals

Front edge draper seals are supplied with the header. These are three long L-shaped pieces bolted to the right rear header panel. Install these seals if:

- Dry material accumulates inside the draper at (A), or between draper and front track (B).
- Wind raises the front edge of the drapers.

IMPORTANT: To prevent damage to drapers, do not use front edge draper seals in wet or muddy conditions. In these conditions, material may pack under the seal, causing damage to the front edge of the drapers.

To install front edge draper seals:

1. Two of the draper seals are the same length. Position one of these at each end of the cutterbar, with the remaining seal in the center.
2. Install seals (C) and retainer clips (D) as shown. Locate a clip at both seal joints, with the remaining clips spaced approximately every eighth guard bolt. **NOTE:** Clips are already installed to retain the movable left deck. Loosen these to allow installation of draper seal.
3. Push retainer clip against draper seal and tighten hardware to lock in position. Draper seal must not touch draper, but clearance is not to exceed 3/16 inch (4.5 mm).

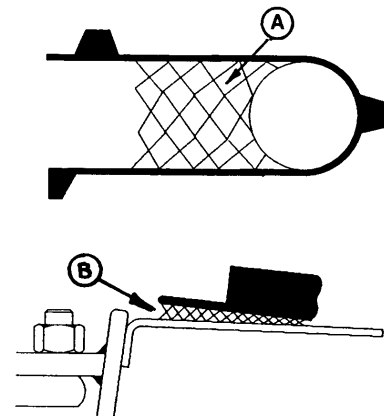

INSTALL DRAPER SEALS TO PREVENT DRY MATERIAL ACCUMULATION

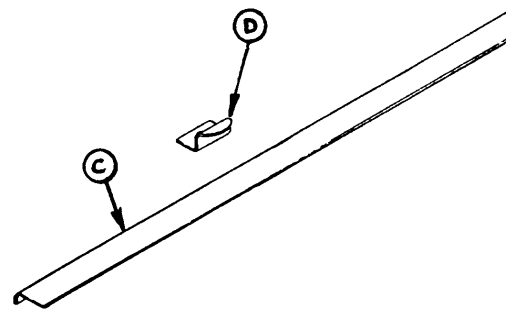

FRONT EDGE DRAPER SEALS AND RETAINER CLIPS

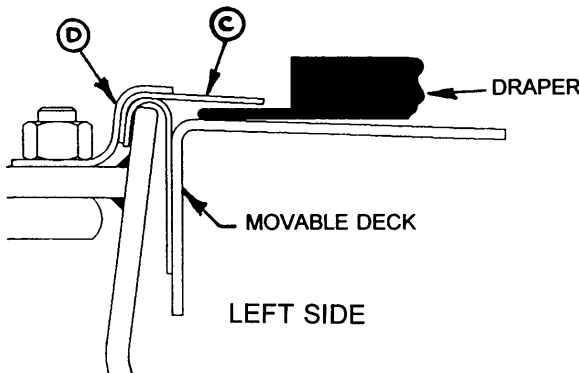

LEFT SIDE

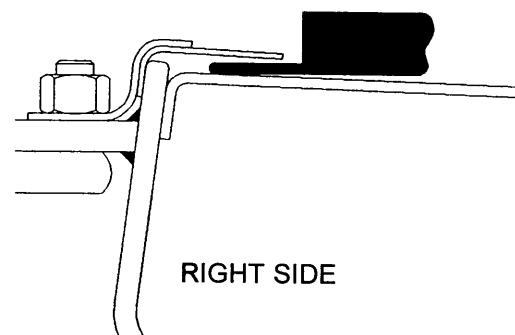

RIGHT SIDE

MAINTENANCE/SERVICE

REEL AND REEL DRIVE

Reel Clearance From Cutterbar

The bat reel should be adjusted to provide 2 inches (50 mm) clearance above cutterbar and/or drapers with reel fully lowered. For pick-up reel clearances, see Reel Operator's Manual.

Check reel clearance whenever the reel fore-aft position is changed.

To increase reel clearance from cutterbar:

1. Lower header and reel fully.
2. At both ends of header: loosen nut (A) and turn adjuster nut (C) clockwise to achieve proper and consistent clearance across cutterbar. Tighten nut (A) against nut (C) to secure the position.

NOTE: For 36' header, in addition to adjusting at each end: At center reel arm, loosen nut (B) and turn nut (D) clockwise. Tighten nut (B) to secure the position.

To decrease reel clearance, loosen nuts (A) and turn nuts (C) counter-clockwise and at 36' center arm, loosen nut (D) and turn nut (B) clockwise.

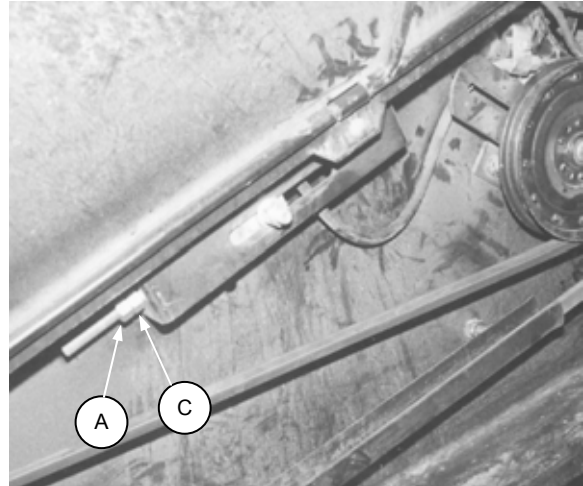

REEL CLEARANCE ADJUSTMENT

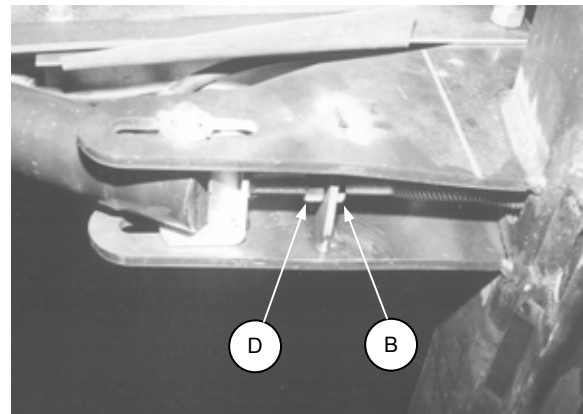

REEL CLEARANCE ADJUSTMENT
36' HEADER - CENTER ARM

Centering the Reel

Center the reel between the header end sheets by adjusting the reel support arm brace (A).

To adjust:

1. Remove nut and offset washer at (E), rear of brace.
2. Position brace (A) as required to center reel.
3. Replace offset washer and nut at (E). Tighten nut to 160 ft.lbs. (215 N·m).

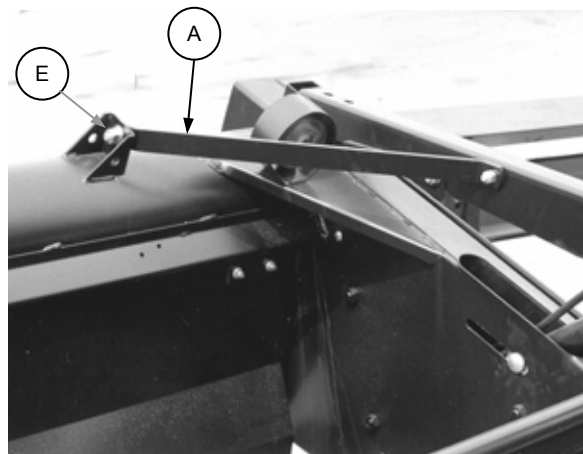

REEL CENTERING ADJUSTMENT

MAINTENANCE/SERVICE

REEL AND REEL DRIVE (continued)

Reel Drive Chain Tension

Check the reel drive chain tension annually.

To adjust:

1. Loosen four bolts (A).
2. Slide motor away from reel shaft until a force of 11 lbs. (50 N) deflects chain 1/8 inch (3 mm) at mid-span.
3. Tighten bolts (A).

Reel Drive Chain Lubrication

Lubricate full length of chain annually with Multi-Purpose Grease.

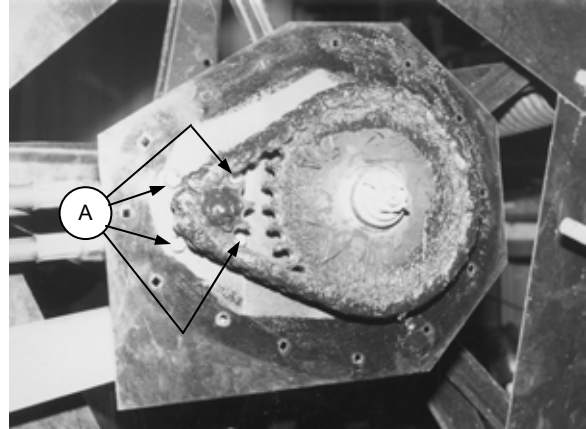

REEL DRIVE CHAIN TENSION AND LUBRICATION

GAUGE WHEELS - 36 FT. STANDARD, 30 FT OPTION

Wheel Bolts

Check and tighten wheel bolts after the first 10 hours of operation and every 100 hours thereafter.

Whenever a wheel is removed and re-installed, check torque after one hour of operation.

Maintain torque as follows:

4-Bolt Hub: 50 to 60 ft.lbs. (70 to 80 N·m)

6-Bolt Hub: 80 to 90 ft.lbs. (110 to 120 N·m)

Follow the proper bolt tightening sequence shown.

NOTE: When installing wheel, be sure valve stem (A) points away from wheel support.

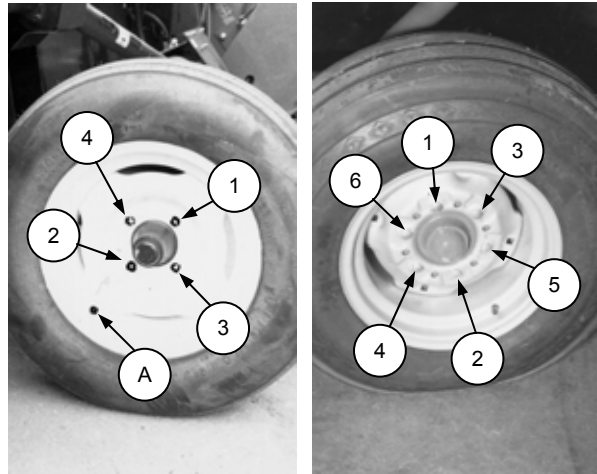

4-BOLT HUB

6-BOLT HUB
GAUGE WHEELS

Gauge Wheel / Transport Casters

Lower casters from both L/H and R/H supports every 500 hours and apply a light coating of Multi-Purpose Grease to the section of caster which engages the support.

NOTE - Headers with Gauge Wheel/Transport Option:
To service left wheel in transport position:

- Block the two rear tires.
- Position jack under mid-point of left end sheet.
- Use a 2 to 3 foot long (60 to 90 cm) piece of wood between jack and end sheet to distribute lifting force and to prevent damage to shield.

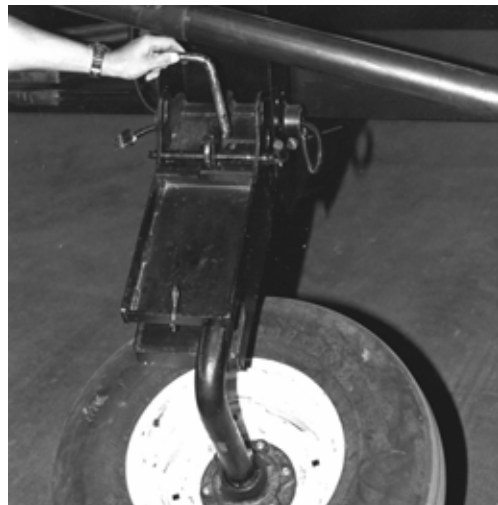

GAUGE WHEEL / TRANSPORT CASTERS

MAINTENANCE/SERVICE

WHEELS AND TIRES (continued)

Tire Inflation

Check tire pressure daily. Maintain pressures recommended in Specifications section.



WARNING: Service tires safely. A tire can explode during inflation and cause serious injury or death. Never increase air pressure beyond 35 psi (241 kPa) to seat the bead on the rim. Replace the tire if it has a defect. Replace a wheel rim which has cracks, wear or severe rust. Never weld a wheel rim. Make sure all the air is removed from a tire before removing the tire from a rim. Never use force on an inflated or partially inflated tire. Make sure the tire is correctly seated before inflating to operating pressure.

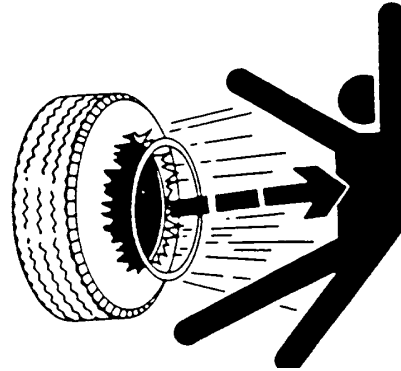

SERVICE TIRES SAFELY

Do not remove, install or make repairs to a tire on a rim unless you have the proper equipment and experience to perform the job. Take the tire and rim to a qualified tire repair shop. If the tire is not in correct position on the rim, or is too full of air, the tire bead can loosen on one side, causing air to leak at high speed and with great force. An air leak of this nature can thrust the tire in any direction, endangering anyone in the area.

(A) - Use a safety cage if available.

(B) - Do not stand over tire. Use a clip-on chuck and extension hose.

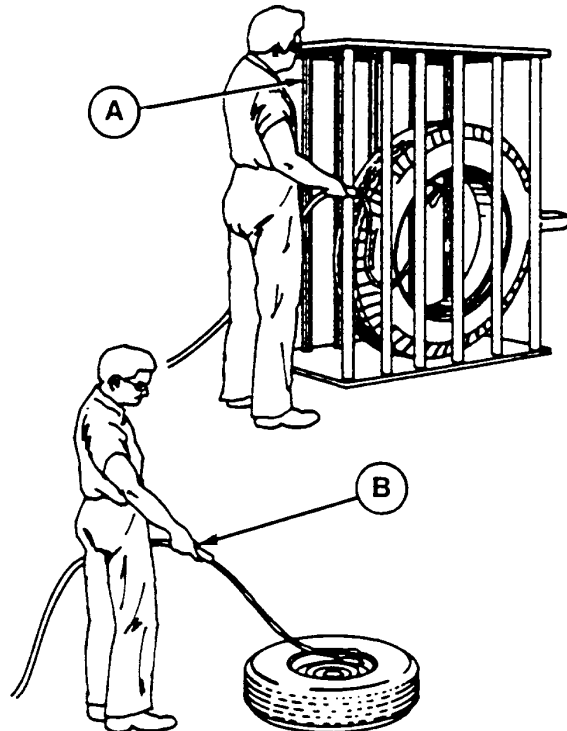

MAINTENANCE/SERVICE

MAINTENANCE SCHEDULE

The following maintenance schedule is a listing of periodic maintenance procedures, organized by service intervals. For detailed instruction, see the specific headings in Maintenance/Service section. Use "Recommended Lubricants" as specified under that heading.

SERVICE INTERVALS

The recommended service intervals are in hours of operation. Use the hour meter in the windrower or combine cab to indicate when the next service interval has been reached.

IMPORTANT: Recommended intervals are for average conditions. Service header more often if operated under adverse conditions (severe dust, extra heavy loads, etc.)

Regular maintenance is the best insurance against early wear and untimely breakdowns. Following this schedule will increase machine life.

Where a service interval is given in more than one time frame, eg. "100 Hours or Annually", service the header at whichever interval is reached first.



CAUTION: Carefully follow safety messages given under "Service Procedures".

AT FIRST USE: See "Break-In Period" in Operation section.

10 HOURS OR DAILY

- | | |
|-----------------------------------------------------------|-------------------------------------------------|
| 1. Grease secondary driveline. | 3. Oil sickle (except in sandy conditions). |
| 2. Check hydraulic hoses, lines and components for leaks. | 4. Check sickle sections, guards and hold-downs |
| | 5. Check tire pressure. |
-

25 HOURS

1. Grease sickle head.
-

50 HOURS

1. Grease reel support bushing(s).
-

100 HOURS OR ANNUALLY *

- | | |
|------------------------------------------------|--------------------------------------------|
| 1. Grease sickle drive shaft support bearings. | 5. Check reel drive chain tension. |
| 2. Check sickle drive belt tension. | 6. Grease reel drive chain. |
| 3. Check wobble box mounting bolts. | 7. Grease split reel connector block (36') |
| 4. Check wobble box lubricant level. | 8. Check wheel bolt torque. |
| | 9. Grease wheel pivot bushings. |
-

END OF SEASON: See "Storage Procedure" in Operation section.

500 HOURS OR ANNUALLY *

1. Grease wheel hub bearings.
 2. Grease gauge wheel transport casters (headers with transport option).
 3. Replace draper drive roller bearings.
-

1000 HOURS OR 3 YEARS

1. Change wobble box lubricant.

* It is recommended that Annual Maintenance be done prior to start of operating season.

MAINTENANCE RECORD

Header Serial No. _____

Combine this record with Windrower or Combine Maintenance Record for "complete unit" service.
See Maintenance/Service section for details on each procedure. Copy this page to continue record.

(G) - Units with gauge wheels or transport option

(T) - Units with transport option only

ACTION:	✓ - Check	⬇ - Lubricate	▲ - Change																				
Hour Meter Reading:																							
Serviced By:																							
Maintenance Procedure																							
BREAK-IN	See "Break-In Period" in Operation section for checklist.																						
10 HOURS OR DAILY																							
⬇	Secondary Driveline																						
✓	Sections, Guards, Hold-downs																						
⬇	Sickle Assembly																						
✓	Hydraulic Hoses and Lines																						
✓	Tire Pressure (G)																						
25 HOURS																							
⬇	Sickle Head																						
50 HOURS																							
⬇	Reel Support Bushing(s)																						
100 HOURS OR ANNUALLY																							
⬇	Sickle Drive Shaft Bearings																						
⬇	Reel Drive Chain																						
⬇	Split Reel Conn. Block (36')																						
✓	Sickle Drive Belt Tension																						
✓	Wobble Box Bolt Torque																						
✓	Wobble Box Lubricant Level																						
✓	Reel Drive Chain Tension																						
✓	Wheel Bolt Torque (G)																						
⬇	Wheel Pivot Bushings (G)																						
500 HOURS OR ANNUALLY																							
⬇	Wheel Hub Bearings (G)																						
⬇	Transport Casters (T)																						
▲	Draper Roller Bearings																						
1000 HOURS OR 3 YEARS																							
▲	Wobble Box Lubricant																						

TROUBLESHOOTING

<u>SYMPTOM</u>	<u>PROBLEM</u>	<u>SOLUTION</u>	<u>REF.</u>
CROP LOSS AT CUTTERBAR			
Heads shattering or breaking off.	Reel speed too fast.	Reduce reel speed.	25
	Ground speed too fast.	Reduce ground speed.	17
	Crop too ripe.	Operate at night when humidity is higher.	---
Cut grain falling ahead of cutterbar.	Reel too high.	Lower reel.	25
	Cutterbar too high.	Lower cutterbar.	18
Does not pick-up down crop.	Cutterbar too high.	Lower cutterbar.	18
	Reel too high.	Lower reel.	25
	Reel too far back.	Move reel forward on support arms.	25
	Ground speed too fast for reel speed.	Reduce ground speed or increase reel speed.	17 25
	Bat reel unsuitable for conditions.	Install pick-up reel.	60
Crop left at dividers.	Divider not gathering crop.	Change divider angle.	26
Strips of uncut material.	Crowding uncut crop.	Allow enough room for crop to be fed to cutterbar.	---
Excessive bouncing at normal field speed.	Float set too light.	Adjust float.	20
Crop build-up at reel lift cylinders.	High crop, like canola, carrying over divider rods.	Cut top bend off divider rods, place plastic tubes over rods to extend height.	---
CUTTING COMPONENTS			
Excessive breakage of sickle sections or guards.	Header angle too steep in stony field conditions.	Flatten header angle or raise header height.	21 18
	Float set too heavy.	Adjust float.	20
	Bent or broken guard.	Straighten or replace.	46

TROUBLESHOOTING

<u>SYMPTOM</u>	<u>PROBLEM</u>	<u>SOLUTION</u>	<u>REF.</u>
CUTTING COMPONENTS (continued)			
Sickle back breakage.	Bent or broken guard.	Straighten or replace.	46
	Worn sickle head pin.	Replace.	44
	Dull sickle.	Replace.	44
	Pitman arm loose at wobble box.	Tighten or replace.	44
Ragged and uneven cutting of crop.	Ground speed too fast.	Reduce ground speed.	17
	Cutting edge of guards not close enough or parallel to sickle sections.	Adjust guards	46
	Sickle hold-downs not adjusted to permit sickle to work freely.	Adjust hold-downs so sickle will work freely, but still keep sickle sections from lifting off guards.	46
	Cutterbar components such as sickle sections, guards are worn, damaged, or broken.	Check and replace all worn and broken cutting components to obtain even cutting of crop.	44
	Cutterbar plugged with material.	Adjust reel to sweep material off cutterbar.	25
	Sickle is not operating at recommended speed.	Check engine speed of windrower or combine.	*
	Bent sickle, causing binding of cutting parts.	Straighten a bent sickle. Check guard alignment and align as necessary for a smooth cut.	44 46
	Top of guard out of adjustment or bent, causing poor shearing action.	Adjust tops of guards so they are parallel to shear edge of guards.	46
	Reel speed too slow.	Increase reel speed.	25
	Loose sickle drive belt.	Adjust belt tension.	47
Excessive vibration of cutting parts.	Sickle is not operating at recommended speed.	Check engine speed of windrower or combine.	*
	Excessive looseness of cutting parts and sickle drive.	Remove excessive play from cutterbar and drive to eliminate vibration. Then make proper adjustments.	44

* See Windrower or Combine Operator's Manual.

TROUBLESHOOTING

<u>SYMPTOM</u>	<u>PROBLEM</u>	<u>SOLUTION</u>	<u>REF.</u>
CUTTING COMPONENTS (continued)			
Sickle plugging.	Loose sickle drive belt.	Adjust belt tension.	47
	Dull or broken sickle sections.	Replace.	44
	Bent or broken guards.	Align or replace.	46
	Improper sickle hold-down adjustment.	Adjust hold-down.	46
	Improper reel adjustment.	Adjust to sweep material off cutterbar.	25
	Improper header float adjustment.	Adjust float springs.	20
	Header angle too steep.	Flatten header angle.	21
	Mud or dirt build-up on cutterbar.	Raise cutterbar.	18
REEL			
Reel will not lift.	Reel lift quick couplers not compatible.	Change quick coupler.	---
Reel seems to lack power (jerky rotation).	Reel speed too fast.	Reduce reel speed.	25
	Reel too low.	Raise reel.	25
	Relief valve on combine or windrower (not on adapter) has incorrect relief setting.	Adjust relief to 2000 psi	*
	Reel too far ahead of sickle.	Move reel back on support arms.	25
	Low oil reservoir level on combine or windrower. (NOTE: Sometimes more than one reservoir.)	Fill to proper level.	*
	Reel wrapping in tangled and weedy crops causing improper reel delivery.	Incorrect location and height of reel.	Place reel well ahead and down.
Reel speed too fast.		Reduce speed of reel to allow weedy crops to fall onto drapers.	25

* See Windrower or Combine Operator's Manual

TROUBLESHOOTING

<u>SYMPTOM</u>	<u>PROBLEM</u>	<u>SOLUTION</u>	<u>REF.</u>
REEL (continued)			
Reel carrying crop over causing improper reel delivery.	Tall grain or nodding varieties of crops catch on reel bats and arms.	Add a second reel bat to each to increase width. (Reel arms have extra holes.)	---
	Reel speed too fast.	Reduce speed of reel so crop will not carry over top of reel. Reel should turn just enough faster than ground speed so that crop heads are laid well back on drapers.	25
	Reel height too low.	Raise reel so bat contacts higher on plant.	25
DRAPERS			
Draper will not drive.	Drapers are loose.	Tighten drapers.	48
	Drive or idler roller wrapped with material.	Loosen draper and clean rollers.	48
	Slat or connector bar jammed by frame or material.	Loosen draper and clear obstruction.	48
	Insufficient clearance between decks in end delivery.	Adjust deck clearance.	24
	Roller bearing seized.	Replace.	39
	Low hydraulic oil.	Fill reservoir to full level.	*
	Incorrect relief setting at flow control valve.	Adjust relief setting.	*
Draper stalling.	Material not feeding evenly off sickle.	Lower reel.	25
		Install stub guards.	**
Dry material accumulates inside or under front edge of draper.	Front edge draper seals not installed.	Install draper seals.	49
Front edge of draper being damaged	In wet/muddy conditions, material packs under draper seals.	Remove front edge draper seals.	49

* See Windrower or Combine Adapter Operator's Manual.

** See your MacDon dealer.

TROUBLESHOOTING

<u>SYMPTOM</u>	<u>PROBLEM</u>	<u>SOLUTION</u>	<u>REF.</u>
WINDROW FORMATION			
Heads on ground (flowered out).	Draper speed too slow.	Increase draper speed.	21
	Draper angle too flat.	Increase draper angle.	21
	Ground speed too slow.	Increase ground speed.	17
	Crop too ripe.	Cut material before too mature.	---
Hollow in center.	Draper speed too slow.	Increase draper speed.	21
	Delivery opening too wide.	Decrease delivery opening width.	21
Heads in center (too much herringbone).	Draper speed too fast.	Reduce draper speed.	21
	Ground speed too fast.	Reduce ground speed.	17
	Crop too green.	Allow to mature.	---
Uneven windrow.	Ground speed too fast for drapers.	Reduce ground speed or increase draper speed.	17 21
	Reel too low.	Raise reel.	25
	Reel too fast.	Reduce reel speed.	25
	Draper angle too steep.	Decrease draper angle.	21
	Material not feeding evenly off of sickle.	Lower reel Install stub guards.	25 * *

* See Windrower or Combine Adapter Operator's Manual.

* * See your MacDon dealer.

OPTIONS AND ATTACHMENTS

Consult your Windrower dealer for details on the following options and attachments.

PICK-UP REEL

WholeGoods order number:

30' – North America: C1372, Australia: C1679

36' – North America: C1373, Australia: C1680

Available for all header sizes, the cam-action pick-up reel is ideal for downed-crop conditions.

Available with replaceable plastic or steel fingers.

A separate Operator's Manual is provided with the pick-up Reel.

Adjust reel clearance after installing pick-up reel. See "Reel Clearance From Cutterbar" in Maintenance/Service section.



PICK-UP REEL

GAUGE WHEELS

WholeGoods order number: B2455

Gauge wheels improve end-to-end float, allowing larger headers to better follow ground contours.

NOTE: When field installing gauge wheels, raise header to ease installation of spring at front end. Be sure header is blocked or cylinder stops are installed.



GAUGE WHEELS

GAUGE WHEEL / TRANSPORT OPTION

WholeGoods order number: C1744

Available as an alternative to the standard gauge wheel package above. This option allows pivoting the gauge wheels 90° to allow towing the header from the left end.



GAUGE WHEEL / TRANSPORT OPTION

OPTIONS AND ATTACHMENTS

SKID SHOES

WholeGoods order number: C1359

Skid shoes are available as an attachment. The primary benefits of skid shoes are:

1. Help prevent damage to cutting components.
2. Reduce scooping of dirt onto cutterbar.
3. Provide a method of setting a minimum cutting height.

See "Skid Shoes" in Operation section for adjustment details.

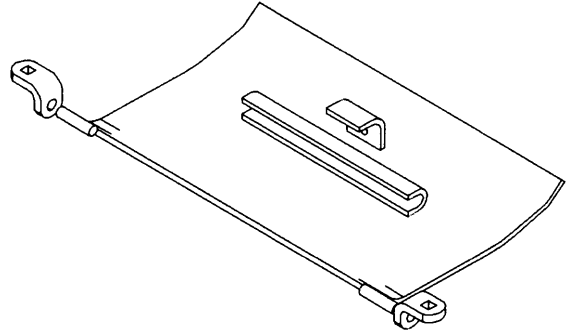

SKID SHOES

HYDRAULIC FORE-AFT REEL POSITIONER

WholeGoods order number:

30' – B2823

36' – B2824

Installation of this kit allows in-cab adjustment of reel fore-aft position on combines equipped with a reel fore-aft hydraulic circuit. This feature shortens header preparation time for truck transport, often used in mobile custom harvest operations. Installation instructions are provided in the Assembly section of this manual.

REEL ARM SLOPE ENHANCEMENT KIT

WholeGoods order number: B2470

Especially recommended for "Rice Special" Headers, this kit raises the rear of the reel support arms for more efficient operation of the pick-up reel with the hydraulic fore-aft reel positioner.

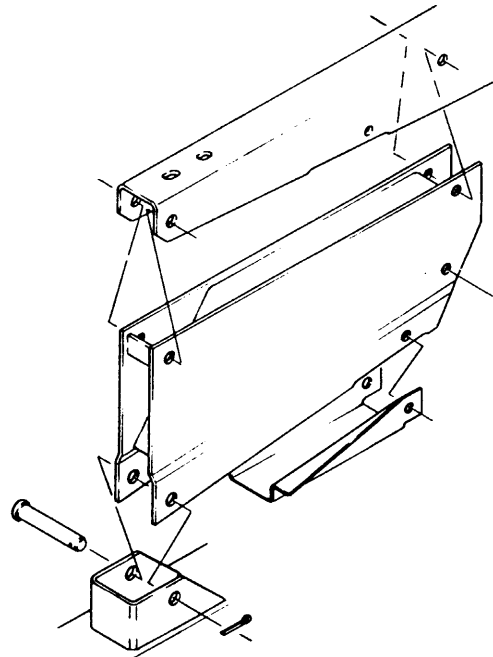

REEL ARM SLOPE ENHANCEMENT KIT

UPPER CROSS AUGER

WholeGoods order number: B2760

For tall or bulky crops, the upper cross auger will aid crop flow across the header and through the delivery opening.

Installation instructions are included with the cross auger.

UNLOADING & ASSEMBLY

PREPARE TO UNLOAD



CAUTION: To avoid injury to bystanders from being struck by machinery, do not allow persons to stand in unloading area.

1. Move trailer into position and block trailer wheels.
2. Lower trailer storage stands.
3. Check that the load has not shifted or otherwise become unstable and check shipping stands for damage before removing hauler's tie-downs. If it appears load is unstable, take precautions to prevent machines falling down when tie-downs are removed.

UNLOADING EQUIPMENT



CAUTION: Unloading equipment must meet or exceed specified requirements. Using inadequate equipment may result in vehicle tipping, chain breakage, or machine damage.

LIFTING VEHICLE REQUIREMENTS

Use a lifting vehicle with minimum 4000 lb. (1815 kg) lifting capacity and a minimum 15 ft. (4.5 m) lifting height.

CHAIN REQUIREMENTS

Use overhead lifting quality chain (1/2 in.) with minimum 5000 lb. (2270 kg) working load limit. Chain length must be sufficient to provide minimum 4 ft. (1.2 m) vertical chain height.

UNLOAD HEADER

1. Attach chain hooks at points (A) and (B) marked "Lift Here".



CAUTION: To avoid injury from shifting or falling machines, remove hauler's tie-downs from one header at a time, after it is secured to unloading vehicle.

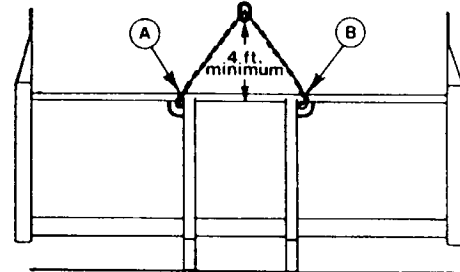

ATTACH CHAIN HOOKS

2. Remove hauler's tie-down straps and chains.



CAUTION: Be sure hooks are secure before moving away from load. Stand clear when lifting, machine may swing. Do not allow anyone to walk under or near the header as it is unloaded or moved.

3. Raise header 12 inches (300 mm) and remove from trailer.
4. Take to storage or set-up area.
5. Set header down securely on level ground. Check for shipping stand damage and remove dividers and other attachments wired to underside of header.
6. Remove chain hooks.



WARNING: Header shipping stands are designed for shipping economy. They do not provide a base broad enough for storage of units in an upright position.

To avoid personal injury, death or machine damage from headers falling or blowing over, proceed with instructions to "Lower Header" (next page) before leaving units in storage.

If it is necessary to store machines upright on shipping stands, ensure that the ground is firm and level. Take factors such as exposure to wind, and the effects of snow melt and ground thaw into consideration. Tie units together and brace on both sides, or place against a secure backstop and brace the unsupported side.

UNLOADING & ASSEMBLY

LOWER HEADER

NOTE: For headers with gauge wheels or gauge wheel/transport package, attach gauge wheel springs to header outer legs before lowering header to ground.

To install springs:

- Position spring inside header leg with open side of spring hook out and install pin (E) and cotter pins.
- Attach spring to clevis (D) (from gauge wheel package). This will later be attached to spring plate in gauge wheel support.
- Repeat at other leg.
- Take care that springs are not damaged as header is lowered.

1. Drive lifting vehicle to approach header from its "underside". Attach chain hooks to points (A) and (B) marked "Lift Here". See "Chain Requirements" in this section for minimum chain specifications.

NOTE: Use angled protectors over cutterbar to prevent chain damaging cutting components.

2. Raise lifting apparatus to take some of the weight off shipping stands and back up SLOWLY to lower header.



CAUTION: Stand clear when lowering, as machine may swing.

3. Place 6" (150 mm) blocks (C) under each end of cutterbar.

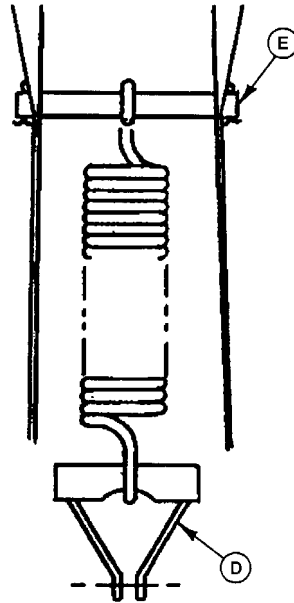

ATTACH GAUGE WHEEL SPRINGS TO HEADER LEGS (OPTION)

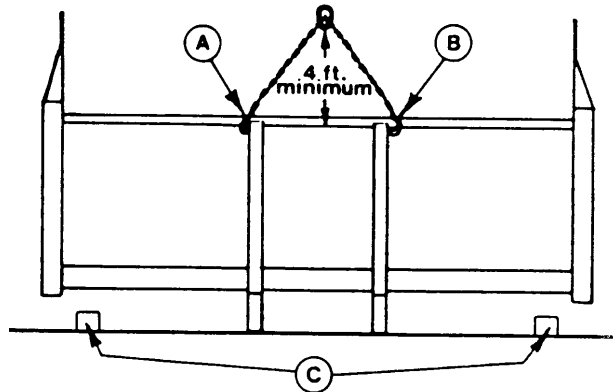

ATTACH CHAIN HOOKS AND PLACE BLOCKS UNDER CUTTERBAR

LOWER HEADER STANDS

For units with gauge wheel or gauge wheel / transport option, see page 64/65.

1. Remove chain hooks and move lifting vehicle to rear of header.
2. Attach chain to center link anchor on frame tube, raise rear of header and lower header stands into position (A) at both outer legs.
3. Lower header onto stands and 6" (150 mm) blocks under cutterbar. Remove shipping stands.

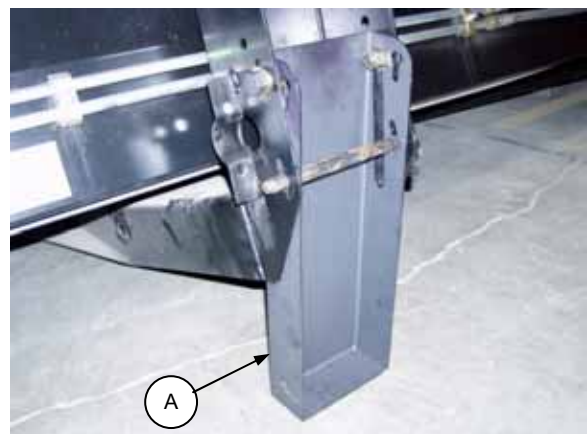

HEADER STAND – LOWERED (BOTH OUTER LEGS)

UNLOADING & ASSEMBLY

INSTALL GAUGE WHEELS (OPTION)

NOTE: These instructions apply to the standard gauge wheel package. For instructions for installing the gauge wheel/transport option, see next page.

1. Remove chain hooks and move lifting vehicle to rear of header. Attach chain to center link anchor on frame tube and raise rear of header.

NOTE: Remove header stands from header outer legs. These stands are not used with gauge wheels.

2. Front end of gauge wheel spring assembly was attached to header outer legs before header was lowered (see previous page). Attach clevis at other end of spring to plate (C) at wheel supports, using 5/8 hex head bolt and lock nut.

NOTE: Do not collapse clevis by over-tightening hardware. Clevis must be free to rotate.

3. Ensure plastic bushings (D) are installed (2 per support). Position wheel support assembly in header leg and install tube (E) from outside header leg through wheel support. Attach two brackets (F) with 1/2 x 1-1/4 inch bolts and nuts to the brackets welded to header leg.

IMPORTANT: Tighten to 80 ft. lbs. (110 N·m). Be sure that welded tab (G) on tube (E) is engaged in slot in bracket (F) on one side. Repeat at other gauge wheel support.

4. Attach gauge wheels to hubs. Torque wheel bolts to 50 to 60 ft.lbs. (70 to 80 N·m).

5. Remove pins securing wheel assemblies and lower to stand position. Secure with pins at (A).
6. Lower header onto gauge wheels and 6" (150 mm) blocks under cutterbar. Remove shipping stands.
7. Check tire pressure. Inflate to 24 to 28 psi (165 to 195 kPa).

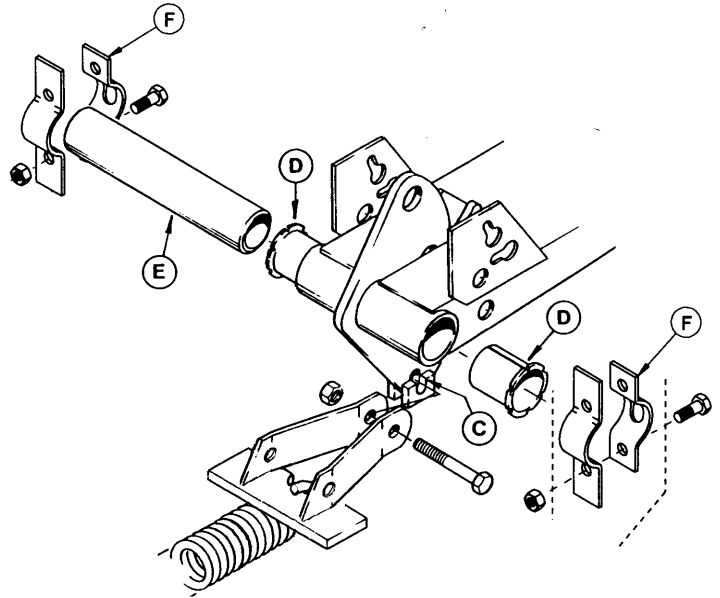

INSTALL GAUGE WHEEL SUPPORTS

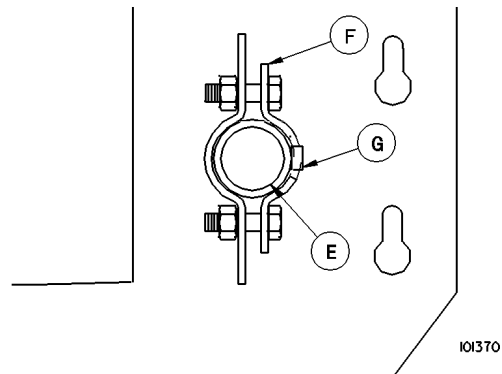

ENGAGE TAB IN BRACKET SLOT

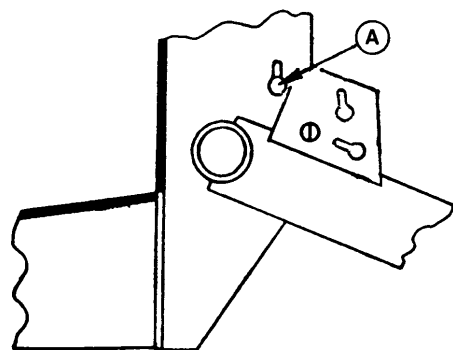

GAUGE WHEELS - STAND POSITION

UNLOADING & ASSEMBLY

INSTALL GAUGE WHEEL / TRANSPORT OPTION

NOTE: These instructions apply to the gauge wheels with transport option. For instructions for installing the standard gauge wheel package, see previous page.

1. Remove chain hooks and move lifting vehicle to rear of header. Attach chain to center link anchor on frame tube and raise rear of header.

NOTE: Remove header stands from header outer legs. These stands are not used with gauge wheels.

2. Identify right and left wheel supports: Left wheel support has single wheel caster, right wheel support is attached to dual wheel beam.
3. Front end of gauge wheel spring assembly was attached to header outer legs before header was lowered (see page 63). Attach clevis at other end of spring to plate (C) at left and right wheel supports, using 5/8 hex head bolt and lock nut.

NOTE: Do not collapse clevis by over-tightening hardware. Clevis must be free to rotate.

NOTE: For ease of installing right wheel support, remove 1/2 inch bolt (H, next page) securing pivot shaft, allowing removal of dual wheel beam.

4. Ensure plastic bushings (D) are installed (2 per support). Position wheel support assembly in header leg and install tube (E) from outside header leg through wheel support. Attach two brackets (F) with 1/2 x 1 1/4 inch bolts and nuts to the brackets welded to header leg.

IMPORTANT: Tighten to 80 ft. lbs. (110 N.m). Be sure that welded tab (G) on tube (E) is engaged in slot in bracket (F) on one side. Repeat at other gauge wheel support.

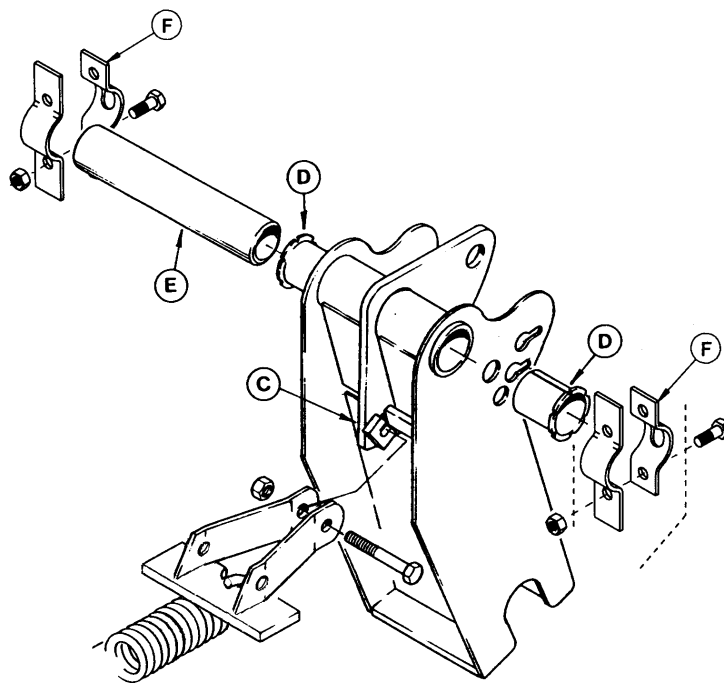

INSTALL WHEEL SUPPORTS (L/H SHOWN)

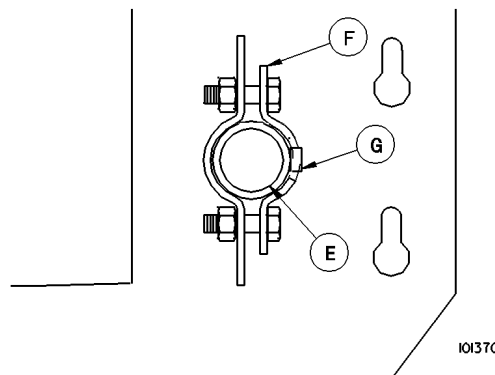

ENGAGE TAB IN BRACKET SLOT

UNLOADING & ASSEMBLY

INSTALL GAUGE WHEEL / TRANSPORT OPTION (continued)

5. Install 1/2 inch hex head bolt (H) and locknut (removed above), attaching dual wheel beam to right wheel support in field position.

NOTE: The pivot shaft on the wheel beam can be installed at right side (A) or left side (B) of wheel support. This allows field positioning of the beam either "inboard" (towards center of header) or "outboard" (towards end of header), as desired. See chart for recommended position depending on power unit.

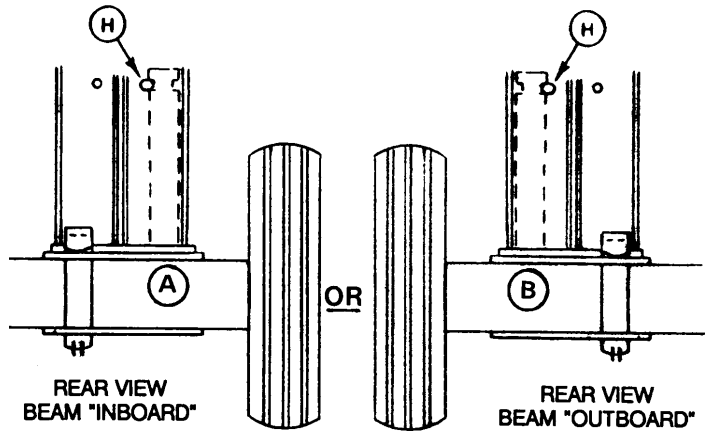

ATTACH RIGHT WHEEL BEAM

H E A D E R	POWER UNIT							
	9000/4900/2900 WINDROWER		9030 TRACTOR: CENTER MOUNT ADAPTER		9030 TRACTOR: OFFSET MOUNT ADAPTER		COMBINE	
	PIVOT SHAFT POSITION	BEAM IN FIELD POSITION	PIVOT SHAFT POSITION	BEAM IN FIELD POSITION	PIVOT SHAFT POSITION	BEAM IN FIELD POSITION	PIVOT SHAFT POSITION	BEAM IN FIELD POSITION
30'	B	OUT	A	IN	A	IN	B	OUT
36'	B or A	OUT or IN	B or A	OUT or IN	B or A	OUT or IN	B or A	OUT or IN

6. Install brace anchor (G) under cutterbar at the 9th guard bolt from center of R/H header leg, replacing standard bolt with 1-3/4" long.

NOTE: If a sickle hold-down or deck support is installed at 9th bolt, relocate hold-down or support to an adjacent location.

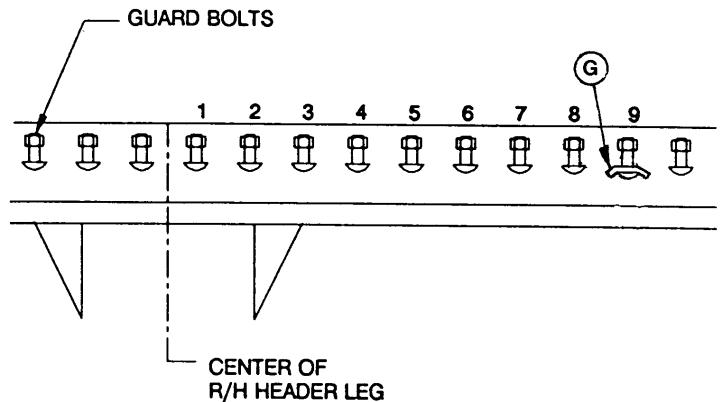

INSTALL BRACE ANCHOR AT CUTTERBAR

UNLOADING & ASSEMBLY

INSTALL GAUGE WHEEL / TRANSPORT OPTION (continued)

7. Attach the three gauge wheels to hubs. Torque wheel bolts to 80 to 90 ft.lbs. (110 to 120 N·m).
8. Install pins (B) in stand position as shown. (Both supports.)

9. Left wheel caster is shipped in field position, with wheel outboard of support.

NOTE: Left wheel caster can be installed at left or right side of wheel support. This positions the left wheel inboard or outboard of wheel support as desired. If caster is being moved to opposite side, note that U-shaped loop (G) on caster must point to middle of wheel support. Access to loop (G) is through slot (H).

10. Lower header onto gauge wheels and 6" (150 mm) blocks under cutterbar. Remove shipping stands.
11. Check tire pressure. Inflate to 42 to 46 psi (290 to 315 kPa).

12. Assemble light package to header as follows:
 - a. Open left hand drive shield and route header section of wiring harness through inside of frame tube to right endsheet.

NOTE: The end of the harness with the 6-way connector goes to the right endsheet.

- b. Route the other end of this harness (with 4-way connector) through slot in left endsheet (see [J] top photo, next page), along driveline shield to left gauge wheel leg, down and through tube which secures wheel support to header leg.

Leaving 22 in. (560 mm) of harness protruding from inboard end of tube (A), use the large plastic ties (E) to secure the harness to driveline shield. For 30 ft. headers, also use one small plastic tie (F) to secure harness at flange on header leg.

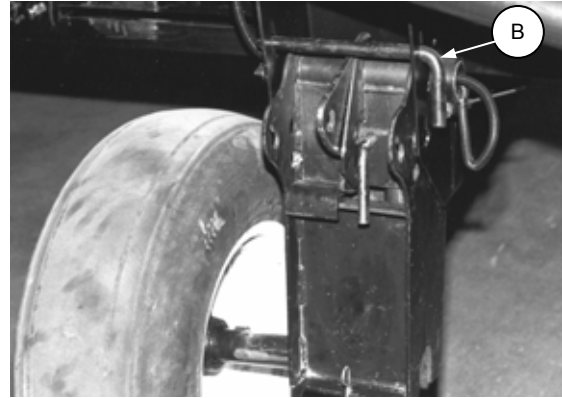

LEG PINS IN STAND POSITION

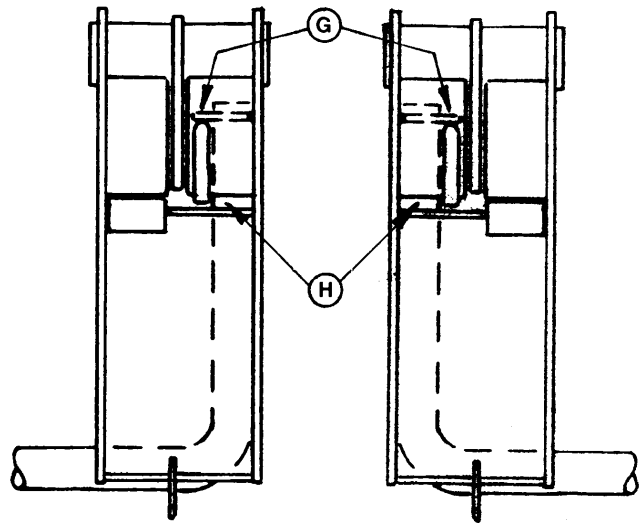

ALTERNATE POSITIONS

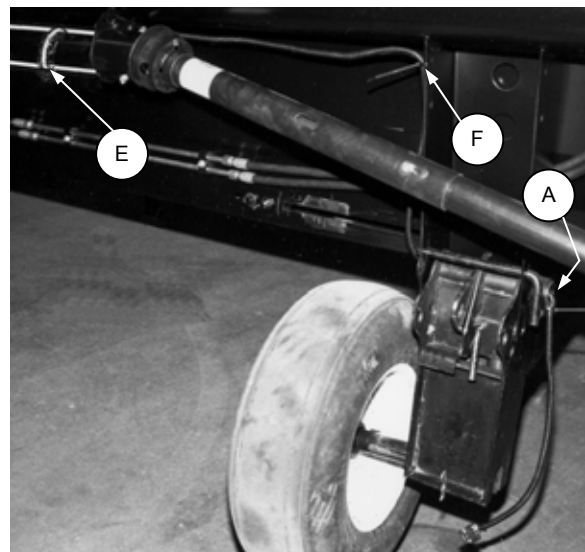

HARNES ROUTING - LEFT WHEEL SUPPORT

UNLOADING & ASSEMBLY

INSTALL GAUGE WHEEL / TRANSPORT OPTION (continued)

12. Assemble light package (continued):
- At left endsheet, attach transport harness ground wire (white) to ground for header lights at (C).
 - Ensure wire cannot reach pulley. If necessary, use small plastic tie at (D) to attach wire to harness at left endsheet.
 - From right end, pull harness through frame tube taut.
 - At the right hand end sheet, install lamp module and support at (N) with the hardware that secures the hydraulic line clamp.
 - Connect header harness and end sheet harness to lamp module. Route longer section of end sheet harness to top of end sheet through hole at reel support arm anchor (S). Route the shorter section of end sheet harness to the inside of end sheet through hole at (P).
 - Install lights at right hand end sheet using the hardware that secures the pivoting amber lights. If shield (X) is installed, install spacer bar (Q) at second bolt to level the mounting surface. Make the wire connections according to the schematic (next page). Cable tie harness at (Y) as shown.

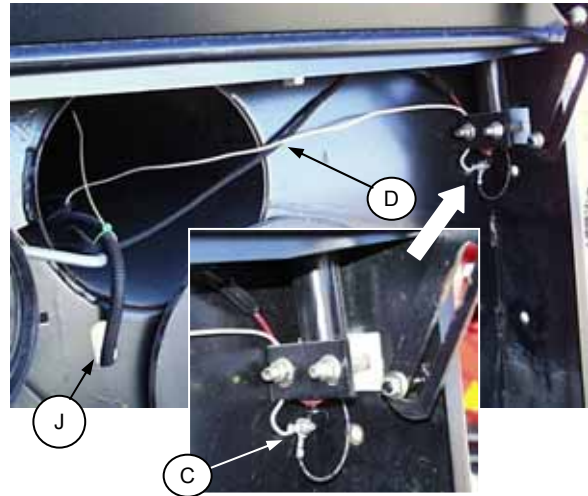

HARNESS ROUTING - LEFT ENDSHEET

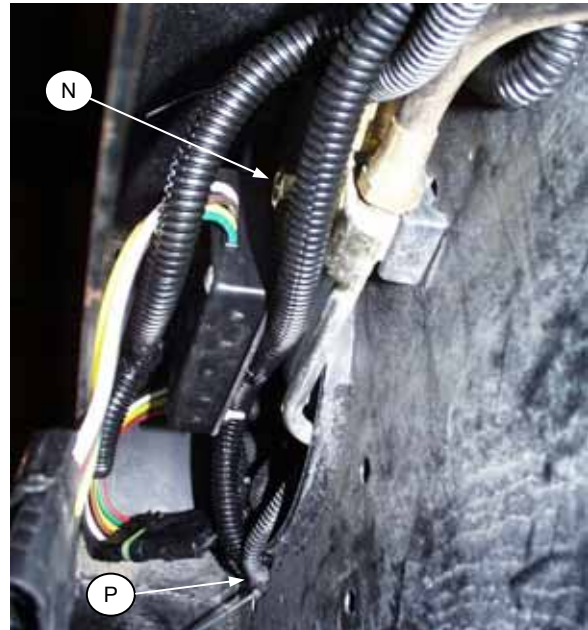

INSTALL LAMP MODULE AT RIGHT ENDSHEET

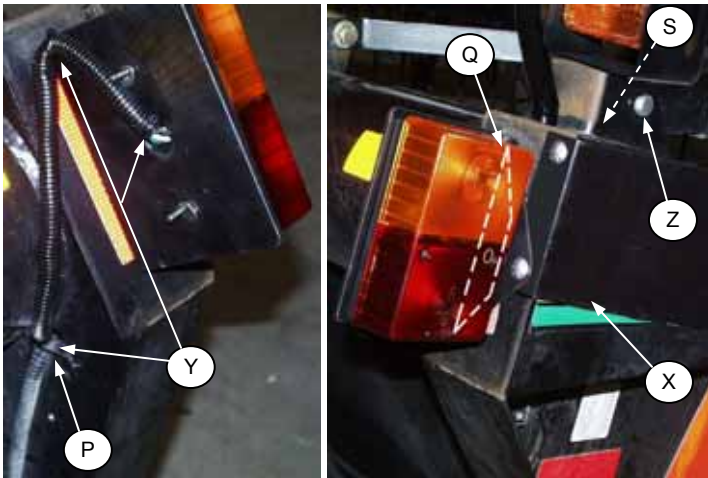

INSTALL LIGHTS AT R/H ENDSHEET

- Install lights at R/H reel support arm using $\frac{1}{2}$ x 1 inch carriage bolts and flange nuts.
- Route harness up inside reel support arm, over rear pivot pin (Z) and over bolts securing reel prop and diagonal brace. Continue to lights at front of reel support arm and make the wire connections according to the schematic (next page). Place wires back inside the conduit and cable tie at (T). Pull excess wiring harness back through reel support arm. Secure excess endsheet harness and header harness to hydraulic line at right endsheet, using small plastic tie.



INSTALL LIGHTS AT R/H REEL SUPPORT ARM

UNLOADING & ASSEMBLY

INSTALL GAUGE WHEEL / TRANSPORT OPTION (continued)

12. Assemble light package (continued): WIRING

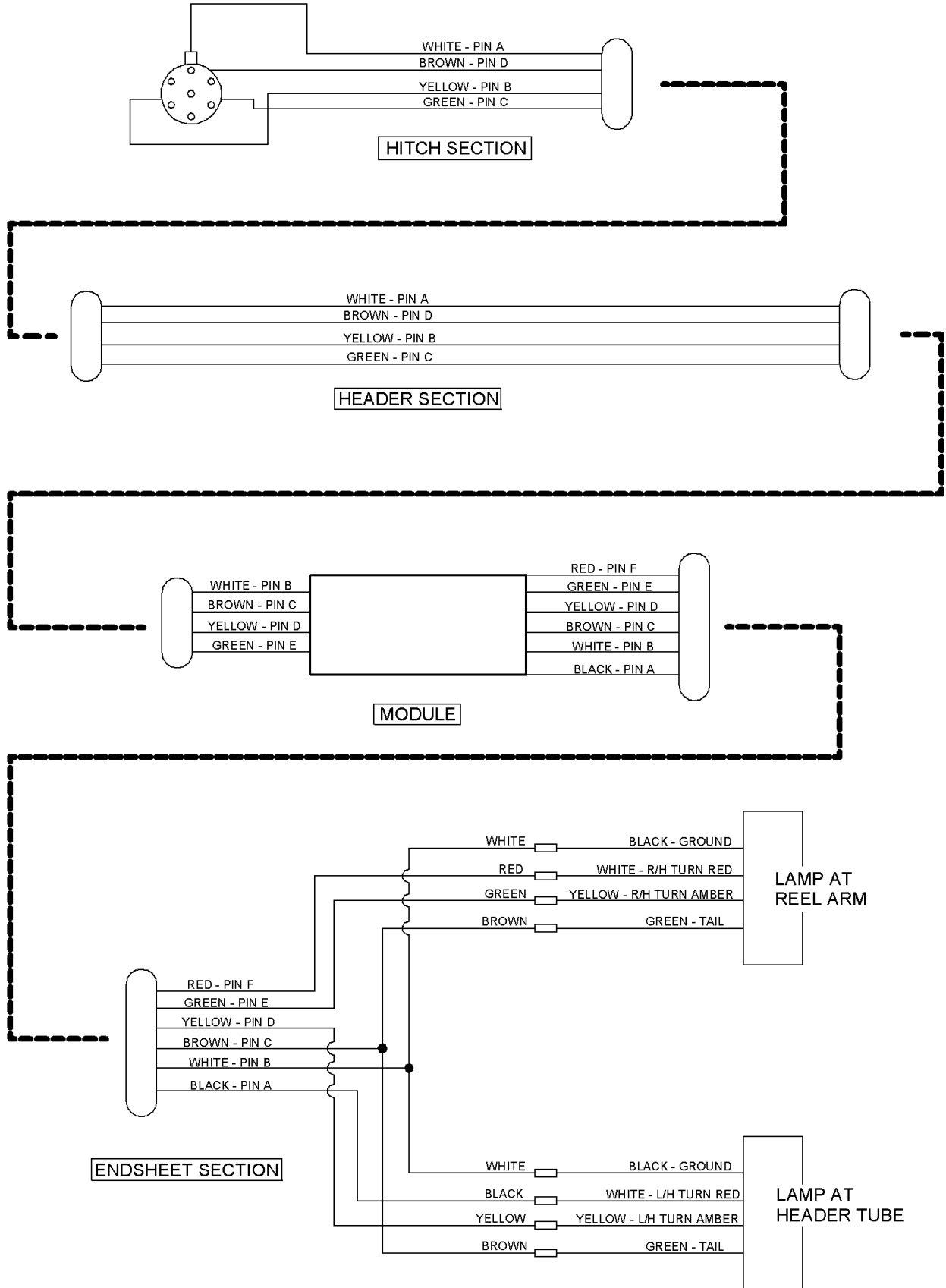

UNLOADING & ASSEMBLY

INSTALL GAUGE WHEEL / TRANSPORT OPTION (continued)

13. Attach Slow Moving Vehicle Emblem at (G).

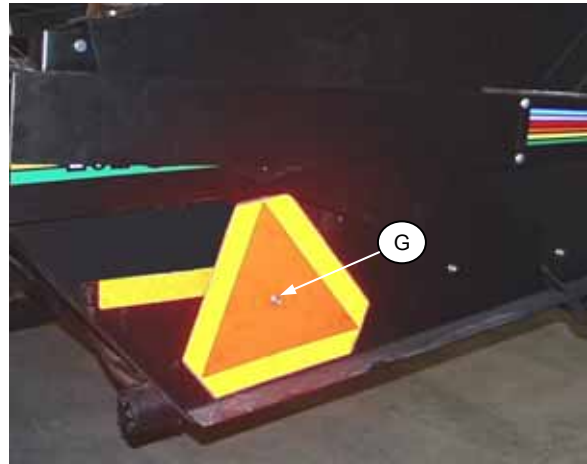

ATTACH SMV SIGN

14. Store hitch on frame tube as follows:

- Remove the following hardware, which is stored in caster clevis at end of hitch:
One 1/2 x 3-1/4 hex head bolt, two locknuts, one flatwasher and one hairpin.
Install this hardware at left endsheet as shown at (A).
- Install hitch support onto bracket welded to frame tube at (B), using two 3/8 x 1 carriage bolts and flange locknuts.
- Place drawbar end of hitch over hardware at (A) and rest other end of hitch in support at (B).

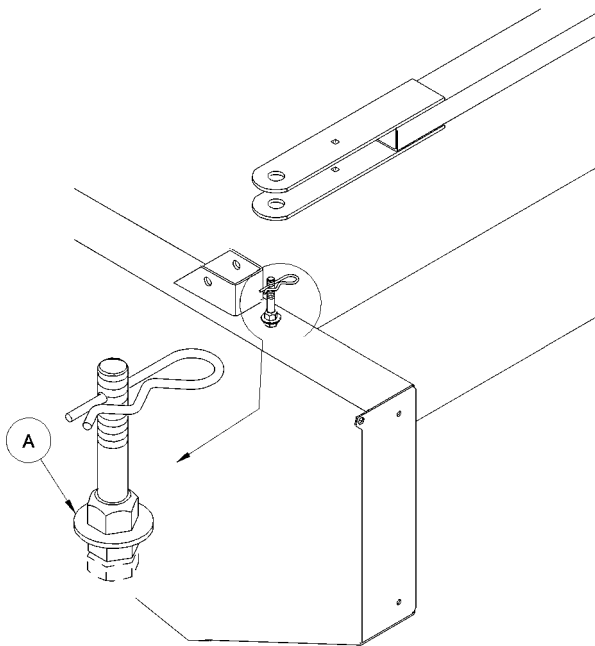

HITCH STORAGE - OUTBOARD END

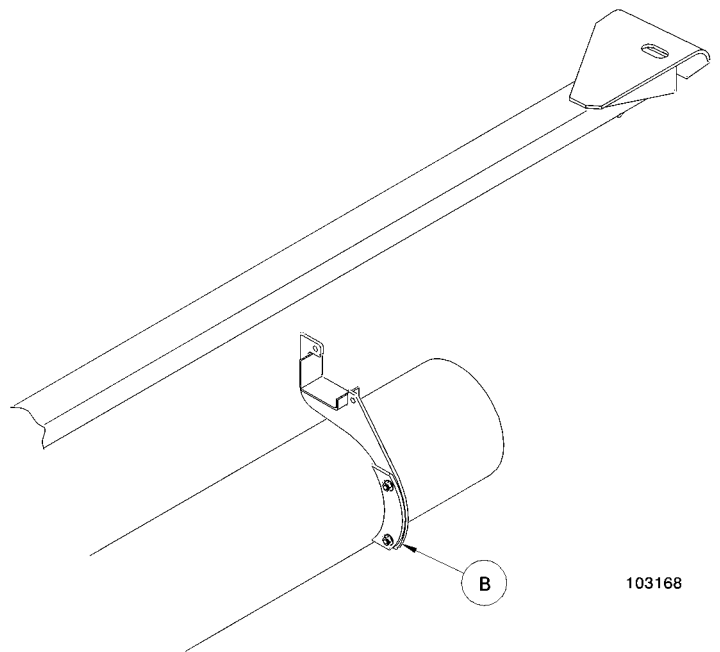

HITCH STORAGE - INBOARD END

103168

UNLOADING & ASSEMBLY

NOTE: For Rice Special Headers only, install reel arm slope enhancement brackets. Instructions are packaged with the brackets. See "Options and Attachments".

ASSEMBLE BAT REEL

1. Remove all strapping and shipping wire and discard away from assembly area.
2. Raise reel support arms and engage reel props (A).

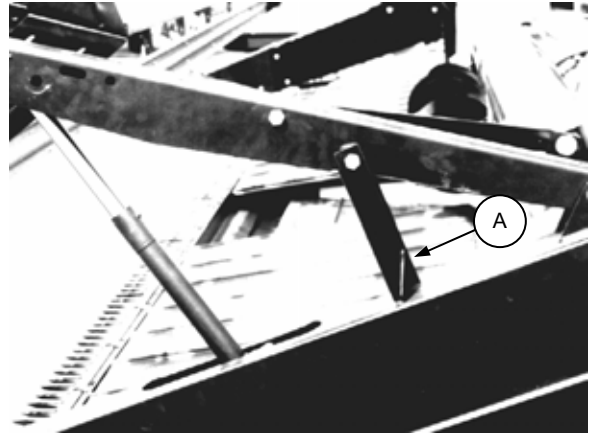

ENGAGE REEL PROPS

3. Loosen positioning screw under reel mounting channels (B) and move channels to desired position. See "Reel Position - Fore & Aft" under Header Operation, page 25. Be sure positioning screw is in the same hole at each reel arm.
4. Attach main reel tube to reel mounting channels.

NOTE: For 36', before attaching tube at reel drive, rotate tube so that the lugs for mounting reel arms on both reel tubes are aligned. This will ensure that reel bats are aligned, not staggered between left and right reels. Also for 36', install reflectors at both ends of header.

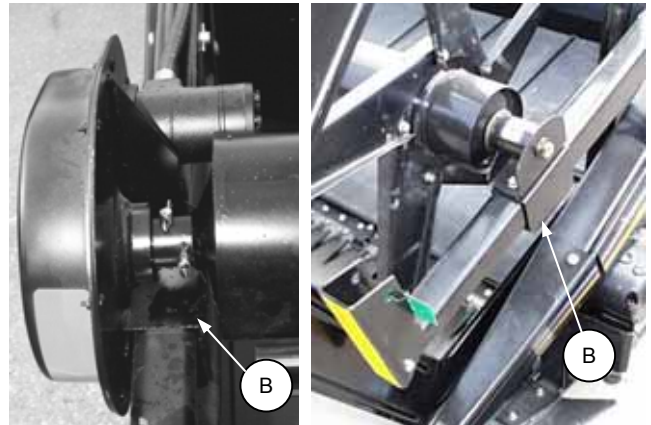

POSITION REEL MOUNTING CHANNELS
AND ATTACH MAIN REEL TUBE

UNLOADING & ASSEMBLY

ASSEMBLE BAT REEL (continued)

NOTE: Install hardware securing arms to tube only finger tight to allow straightening after assembly.

5. Fasten reel arms to main reel tube using round (carriage) head bolts and flange nuts.



FASTEN REEL ARMS TO MAIN TUBE

6. Attach bats to reel arms using flange head bolts and flange nuts.

NOTE: The end of the bat where the distance from the holes for the reel end shields to the next set of holes is 4 inches (100 mm) must be positioned at the reel motor.

7. Fasten the reel ends to the bats using flange head bolts and flange nuts (finger tight only).
8. Straighten the bats by sighting down the length of one bat, making adjustments to the reel arms until that bat is acceptably straight, then tightening the appropriate bolts at the reel tube to secure the position. Working clockwise (from the left end of the header), repeat the procedure at the next bat.

NOTE: In order to straighten the last bat, it may be necessary to loosen the bolts at the tube which are common to the first and last bat.

If, after this procedure, bats do not appear straight, loosen hardware as required to adjust.

9. Tighten the hardware securing the reel ends to the bats.
10. Adjust reel clearance from cutterbar. See Maintenance/Service section, page 50.
11. Adjust reel brace position at (A) to center the reel between the left and right end sheets. See Maintenance/Service section, page 50.

NOTE: Instructions for assembly of the Hydraulic Fore-Aft Reel Positioner option start on page 81.



ATTACH BATS TO REEL ARMS

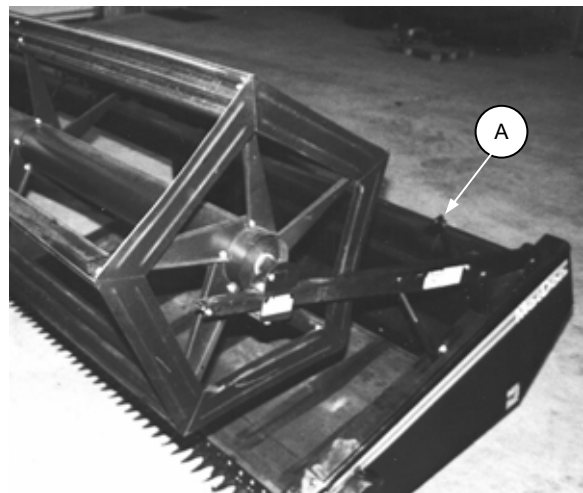

ATTACH REEL ENDS TO BATS
AND CENTER REEL WITH BRACE

UNLOADING & ASSEMBLY

INSTALL DRAPERS

NOTE: For delivery openings of 41.7" (1060 mm) and smaller, before installing draper, install draper supports (S) at cutterbar side of idler roller bars using 3/8 x 3/4 carriage head bolts and flange nuts. For larger openings, remove supports (S), if installed.

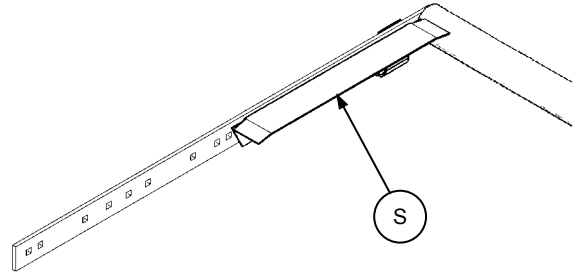

NOTE: Right and left side drapers are different lengths. Be sure you have the drapers properly positioned. Drapers are marked with an identification number. Always install the lower number on the left side.

30' Header: Left side draper #100265 Right side draper #100266
 36' Header: Left side draper #100267 Right side draper #100268

CONNECTION	CENTER DELIVERY OPENING WIDTH (W) (between rollers)	LEG TO ROLLER EDGE (DIM. X)	DESIGNATED APPLICATION and COMMENTS
Row A to Row F (both drapers)	33.9" (860 mm)	22.4" (568 mm)	Opening for combine models: Case 60 & 66 Series, NH-TR and CR 920/940/960 & Gleaner
Row A to Row G (both drapers)	39.7" (1010 mm)	19.4" (493 mm)	Opening for Case 77, 80 & 88 series combines
Row A to Row E (both drapers)	41.7" (1060 mm)	18.4" (468 mm)	Opening for CNH AFX, NH-CR 970/980, Challenger 660 and MF 9690
Row A to Row H (both drapers)	49.6" (1260 mm)	14.4" (365 mm)	Opening for Lexion 450, 460R, 470, 470R, 475, 560, 560R, 570R, 575R, 580, 580R & 585R Combines
Row J to Row D (both drapers)	53.5" (1360 mm)	12.4" (315 mm)	Opening for combine models: JD STS, CTS, 9500, 9510, NH-TX / CX, Challenger 670 and MF 9790
Row A to Row C (both drapers)	59.5" (1510 mm)	9.6" (243 mm)	Opening for combine models: JD 9600, 9610, 9650 and Lexion 460, 465, 480, 480R, 485 & 485R Combines
Row A to Row B (both drapers)	65.8" (1670 mm)	6.4" (163 mm)	Maximum opening for windrowing

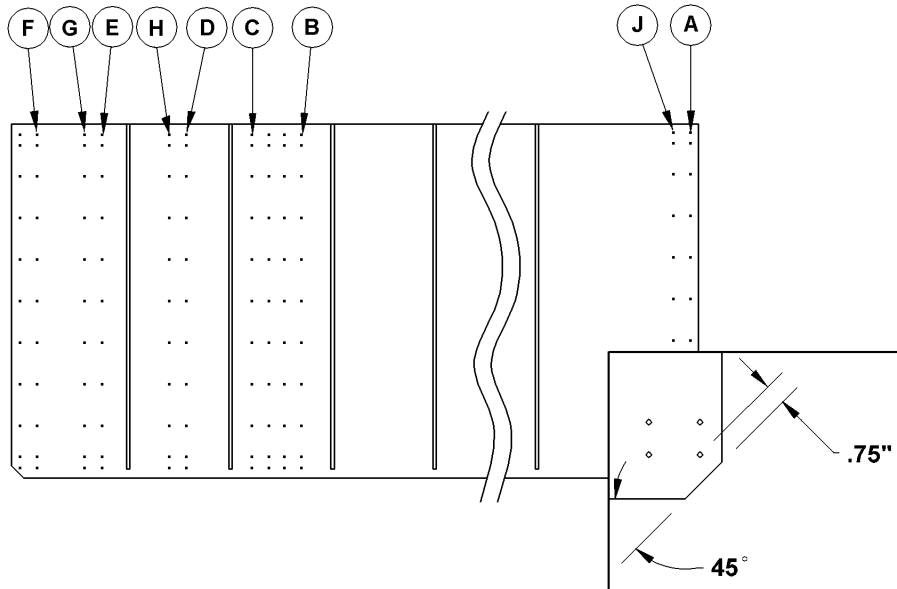

UNLOADING & ASSEMBLY

INSTALL DRAPERS (continued)

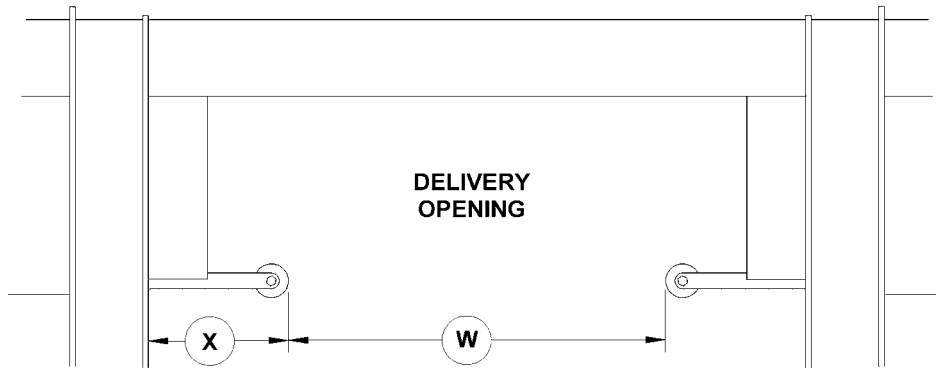

1. Use the chart on page 73 to position draper connector tubes at the appropriate rows of holes and position rollers at center opening for the desired application.

NOTE: For combine applications with 38" feed draper deck, prior to installing drapers, install draper supports on idler roller bars as shown on page 73.

Bolt opening adjustment bars to deck at the hole corresponding to the draper row. For example if drapers are to be connected at row E (from chart on previous page), move roller until hole (E) aligns with deck mounting slot. Use a carpenter's square to ensure roller is square to deck and tighten hardware.

NOTE: For access to bolt securing the adjustment bar at cutterbar on L/H (moveable) deck, remove retainer clips (K). Raise front of deck for access to bolt.

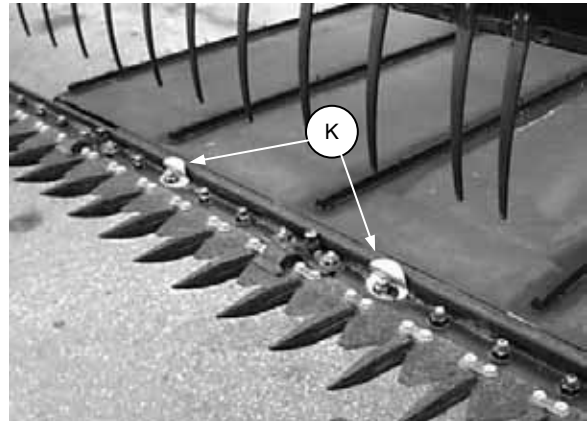

REMOVE CLIPS ON LEFT DECK FOR BOLT ACCESS

ROLLER ATTACHMENT

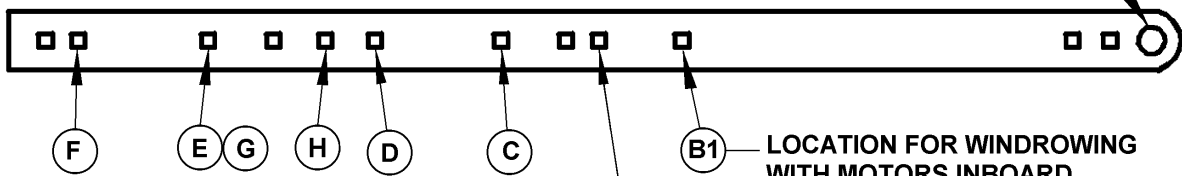

2. Cut excessive flap off of draper, leaving 3/8" (10 mm) extending above the connector. Trim the new ends at the front corners as shown on page 73. This allows draper to fit properly under front draper seal to prevent tearing of front edge. Use the cut-offs as a guide for trimming. Keep the cut-offs for use as a splice.

3. **NOTE:** Place connector tube so holes closest to end of tube are at the cutterbar. Connect draper with screw heads (C) facing center opening.

4. Apply draper tension. See "Draper Tension Adjustment" in Maintenance/Service section, page 48.

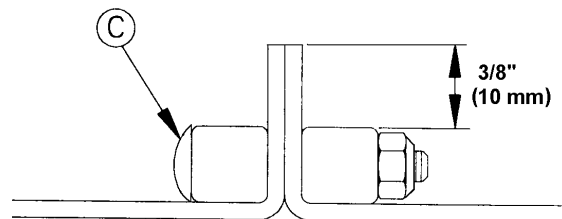

SCREW HEADS FACE CENTER OPENING

CONNECTOR SCREW HEADS

UNLOADING & ASSEMBLY

INSTALL DRAPERS (continued)

5. Backsheet extension panels (L) are shipped in outboard position. For narrower opening sizes (roller positions E, F or G) panels may be moved inboard to improve feeding. Use adjustment bar hole (B1) to secure panel in inboard position.

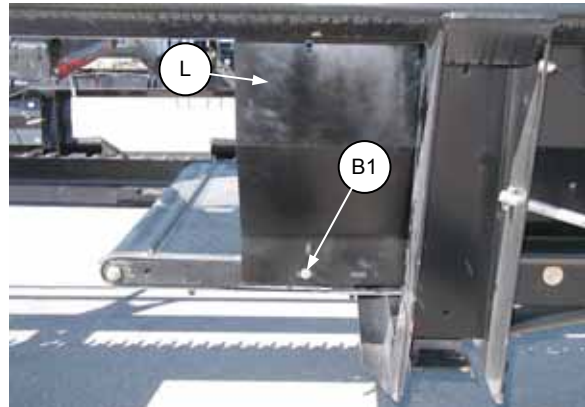

INSTALL COUPLER ON HEADER REEL LIFT LINE

30':

Install quick coupler and hose extension supplied with windrower or combine adapter package on reel lift line (D) at header left leg.

36':

Install quick coupler and hose extension supplied with windrower or combine adapter package on reel lift hose (E) at header left leg.

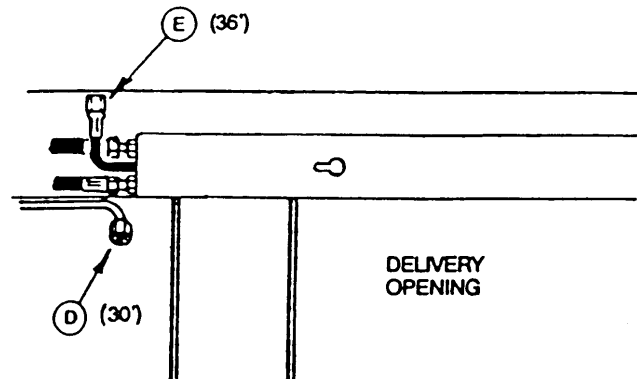

INSTALL REEL LIFT HOSE & COUPLER

PREPARE HEADER FOR WINDROWER OR COMBINE

See the Assembly section of your Windrower Tractor or Combine Adapter Operator's Manual for instruction related to preparing the Model 963 Header for a particular power unit.

UNLOADING & ASSEMBLY

PREPARE HEADER FOR WINDROWER OR COMBINE (continued)

Sickle Drive Assembly

The sickle drive assembly at the left end of the header varies depending on the application (windrower or combine).

Ensure that the assembly is correct for your application. When converting from windrower to straight-cutting or vice-versa, reassemble drive components as shown.

ASSEMBLY A: For windrower applications and 802 Bi-Directional Adapter

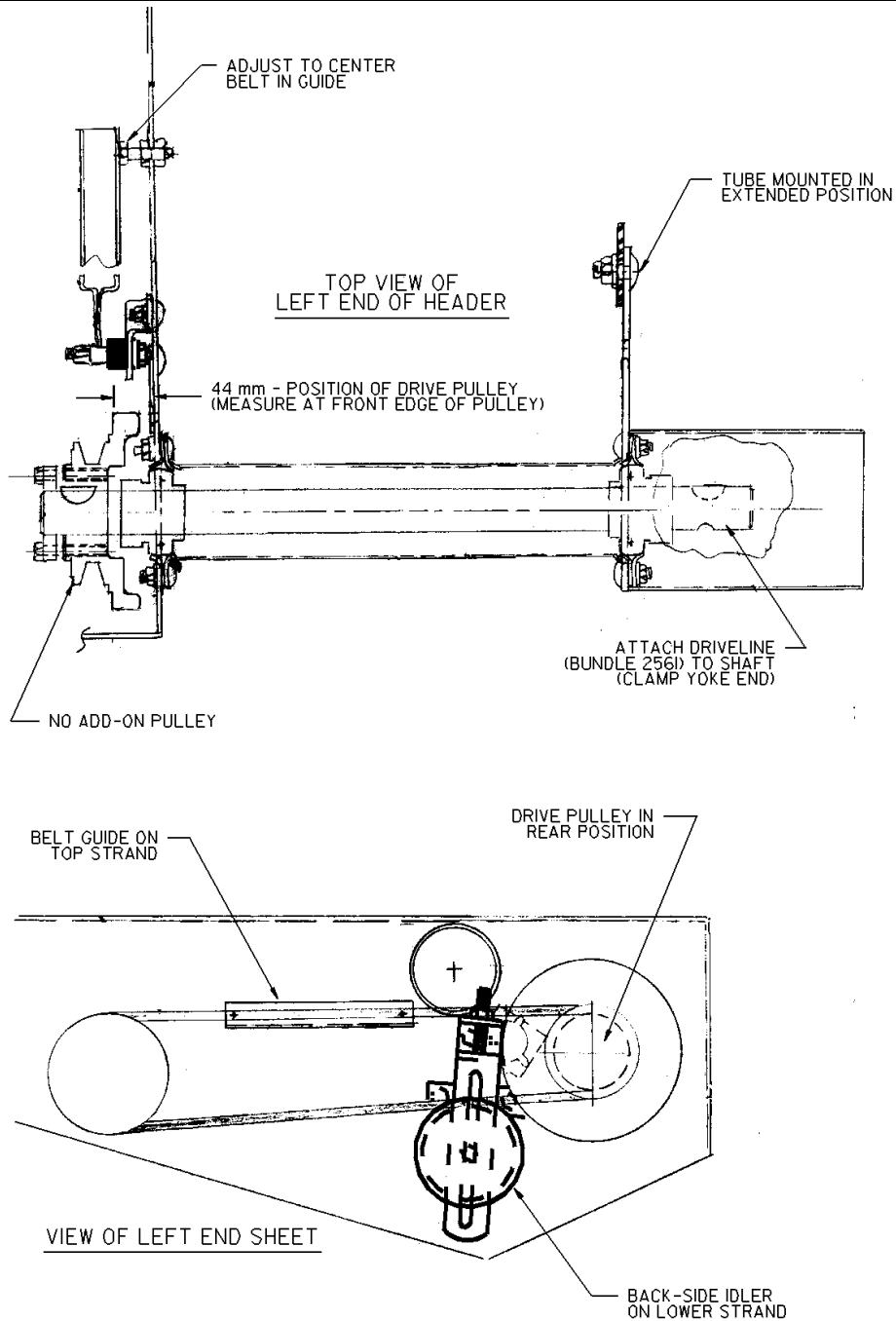

100929

UNLOADING & ASSEMBLY

PREPARE HEADER FOR WINDROWER OR COMBINE

Sickle Drive Assembly (continued)

ASSEMBLY B: For Combine Adapters and 801 Bi-Directional Adapter

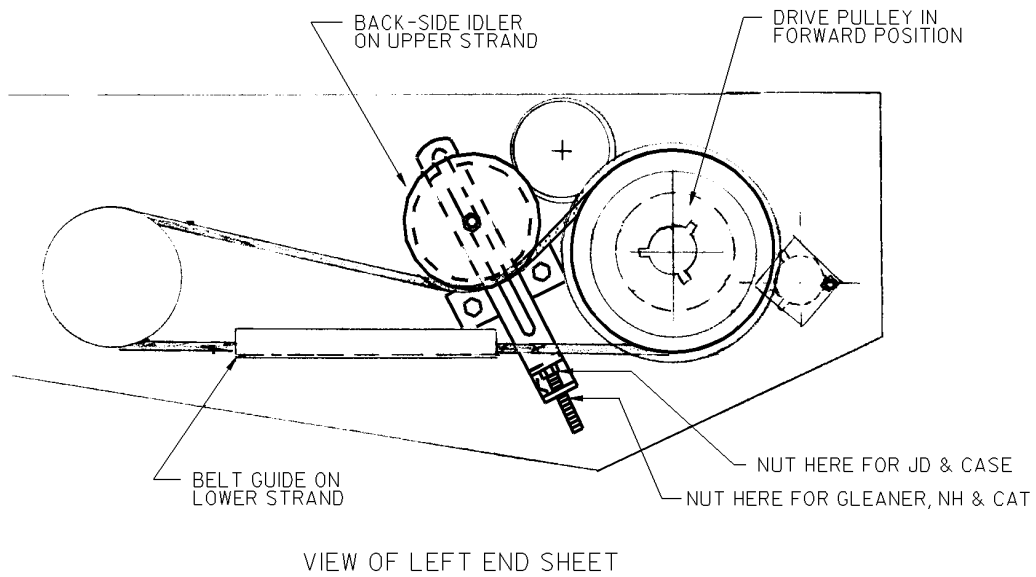
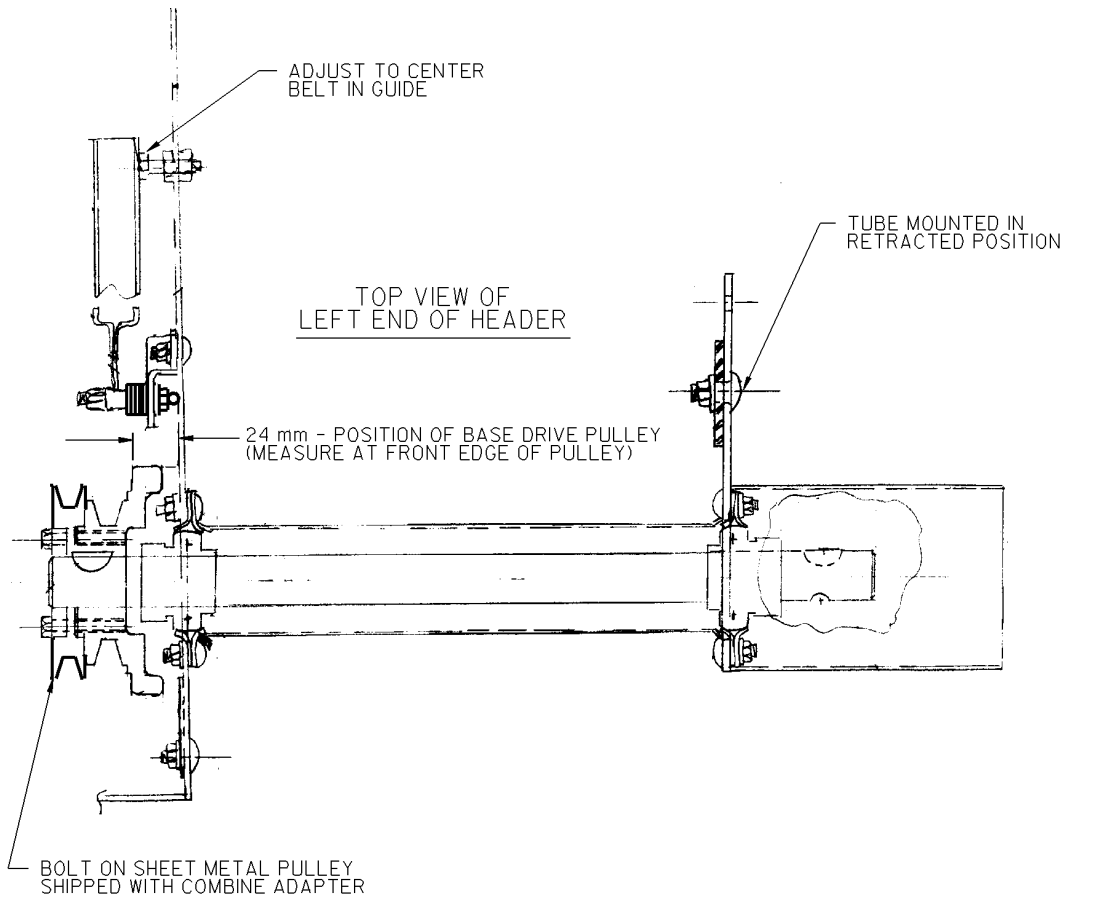

I00928

UNLOADING & ASSEMBLY

PREPARE HEADER FOR WINDROWER OR COMBINE (continued)

Moving Draper Motors

Draper drive motors may be moved from outboard to inboard and vice versa. The inboard configuration provides more conveying torque in heavy crops and is for windrowing applications only. The maximum delivery opening is recommended with motors inboard.

In combine applications motors must be in outboard configuration because of interference with adapter conveyors.

Moving Motors From Outboard to Inboard

1. The following parts must be purchased from your dealer:

- Part No. **43768** - Hose, quantity 1
- Part No. **101917** - Hose, quantity 1
- Part No. **50103** - 45° Elbow - 7/8 O-ring x 7/8 JIC, quantity 4

2. Loosen and remove drapers.
 3. Remove hoses from draper drive motors and remove hardware connecting drive roller assembly to tensioning bars.
 4. Remove hardware connecting opening adjustment bars to deck and remove complete idler roller assembly.
 5. Remove idler roller from opening adjustment bars.
 6. Install idler roller on tensioning bars.
 7. Attach drive roller to opening adjustment bars, using hardware from outer end.
- NOTE:** At R/H side, do not re-use support 103188 from outer end.
8. Install drive roller assembly in deck at widest opening position. See page 74.
 9. Route hoses as shown.

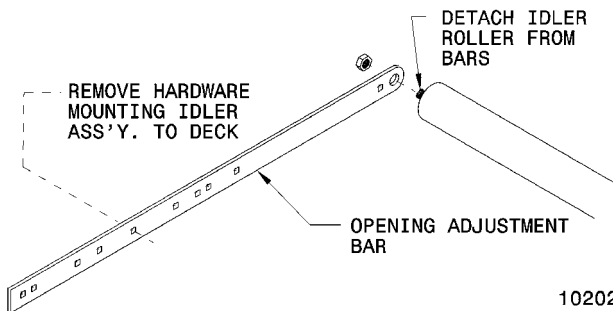
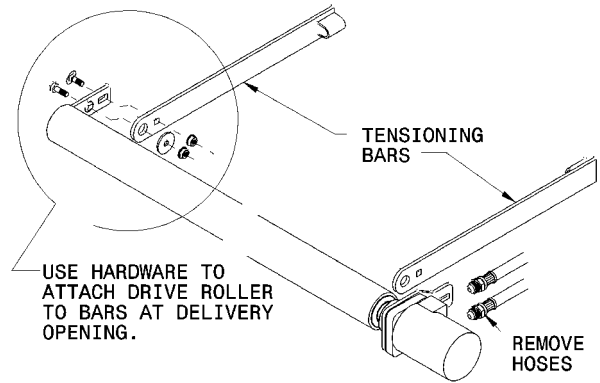

102026

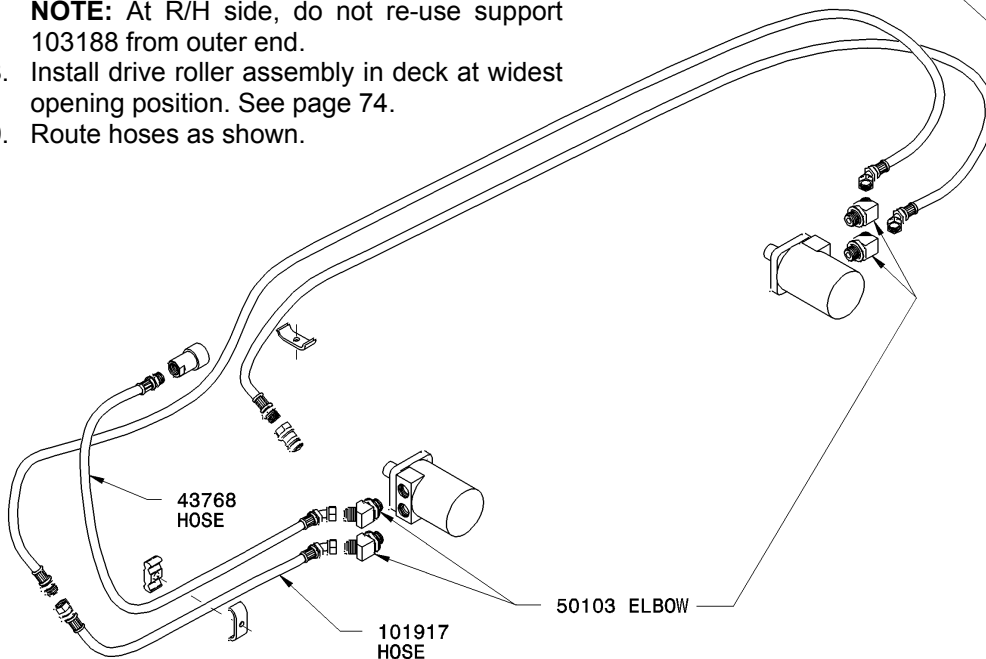
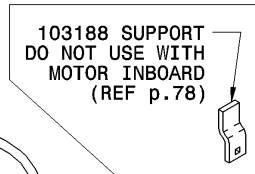

UNLOADING & ASSEMBLY

PREPARE HEADER FOR WINDROWER OR COMBINE (continued)

Moving Motors From Inboard to Outboard

1. The following parts must be purchased from your dealer:

30' Header

- Part No. **43615** - Hose , quantity 2
- Part No. **101916** - R/H Line, quantity 2
- Part No. **30558** - Union, 7/8 JIC, quantity 2
- Part No. **32225** - Holder, quantity 4
- Part No. **37167** - Holder, quantity 4
- Part No. **50197** - Bolt, Carr. 3/8 x 1-3/4, qty.4
- Part No. **30228** - Nut, Lock 3/8, Quantity 4
- Part No. **103188** - Support, Quantity 1
- Part No. **21484** - Bolt, Carr. 3/8 x 1-1/2, qty.1

36' Header

- Part No. **43615** - Hose , quantity 4
- Part No. **43671** - L/H Line, quantity 2
- Part No. **43667** - R/H Line, quantity 2
- Part No. **30558** - Union, 7/8 JIC, quantity 3
- Part No. **32225** - Holder, quantity 6
- Part No. **37167** - Holder, quantity 6
- Part No. **50197** - Bolt, Carr. 3/8 x 1-3/4, qty.6
- Part No. **30228** - Nut, Lock 3/8, Quantity 6
- Part No. **103188** - Support, Quantity 1
- Part No. **21484** - Bolt, Carr. 3/8 x 1-1/2, qty.1

2. Loosen and remove drapers.
3. Remove hoses from draper drive motors.
4. Remove hardware connecting opening adjustment bars to deck and remove complete drive roller assembly.
5. Remove drive roller assembly from opening adjustment bars.
6. Remove hardware connecting idler roller assembly to tensioning bars.
7. Install idler roller assembly on opening adjustment bars.
8. Attach drive roller assembly to tensioning bars, using hardware from inboard end. At R/H side, install support 103188 as shown, using 1-1/2" long carriage bolt instead of 1".
9. Install idler roller assembly in deck and adjust opening size. See page 74.
10. Route hoses as shown.

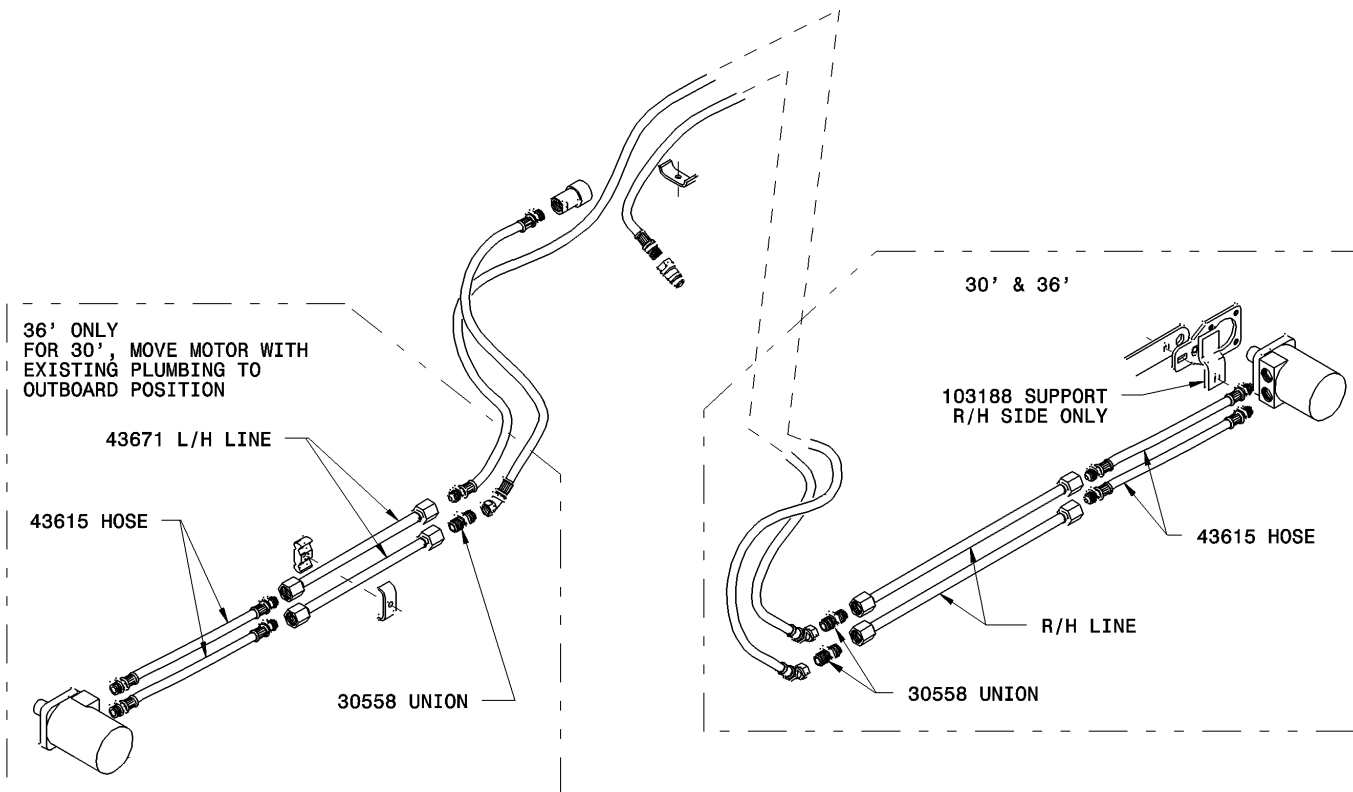

UNLOADING & ASSEMBLY

ATTACH HEADER



CAUTION: Read the Operator's Manuals carefully to familiarize yourself with procedures and controls before attaching header to windrower or combine. Attaching instructions are provided in the Windrower Tractor and Combine Adapter Operator's Manuals.

BLEED HYDRAULIC SYSTEM

Header Lift Cylinders

Raise and lower header a few times to allow trapped air to pass back to the reservoir.

Reel Lift Cylinders



CAUTION: Take care during this procedure as air in the system can cause the reel to raise and lower erratically. Keep body and hands out from under reel and reel support arms.

IMPORTANT: If a pick-up reel is installed: To prevent twisting damage to reel, complete this procedure before installing finger pitch adjustment bolts. See Pick-Up Reel Operator's Manual.

1. Fully lower header and reel.



CAUTION: Bleed screw (A) may be forced from hole by hydraulic pressure. Do not loosen screw too quickly or too far.

2. SLOWLY loosen bleed screw (A) in right hand reel lift cylinder. (For 36 ft. header, bleed screw is in left hand cylinder.)
3. Start engine and activate reel lift. Left hand cylinder will reach full extension first, then oil will pass to right hand cylinder. (For 36 ft. header, sequence will be: center cylinder, R/H cylinder, L/H cylinder.)
4. Continue to activate reel lift until oil comes out around bleed screw.
5. Tighten bleed screw.



REEL LIFT CYLINDER BLEED SCREW
(36 FT. SHOWN - 30 FT AT R/H)

REPOSITION WOBBLE BOX BREATHER

Unless header will be transported on a trailer that carries headers upright, swap position of plug (B) and breather (C) at wobble box, so breather is in rear hole.

ADJUSTMENTS & CHECKS

Perform final adjustments and checks as listed on the "Pre-Delivery Checklist" (yellow insert) to ensure the machine is field-ready. Use the Operator's Manual for directions.

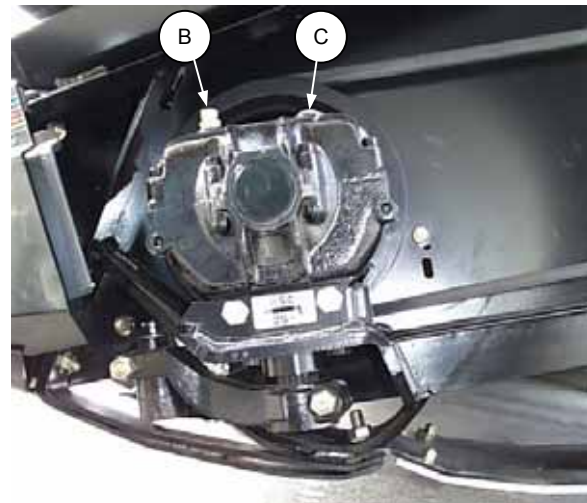

REPOSITION WOBBLE BOX BREATHER

UNLOADING & ASSEMBLY HYDRAULIC REEL FORE-AFT KIT INSTALLATION INSTRUCTIONS

1. Attach cylinder to reel drive at:
 - R/H reel support arm (30' Header)
 - Center reel support arm (36' Header)

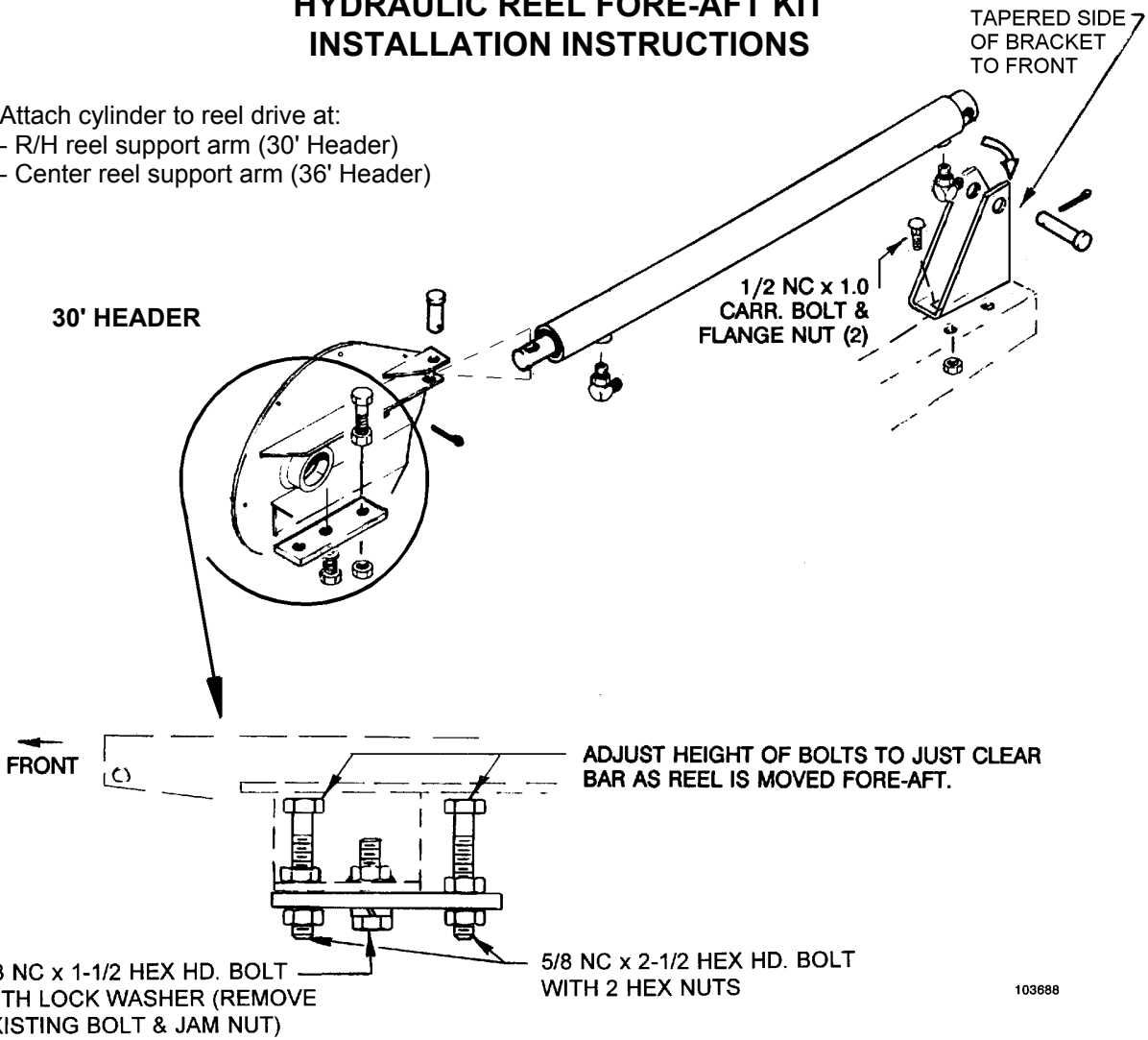

103888

NOTE: Install tapered side of bracket to front unless part interferes with cab when header and reel are raised. Check this carefully once assembly is complete. If more clearance is required, reverse bracket to have tapered side to rear.

36' HEADER

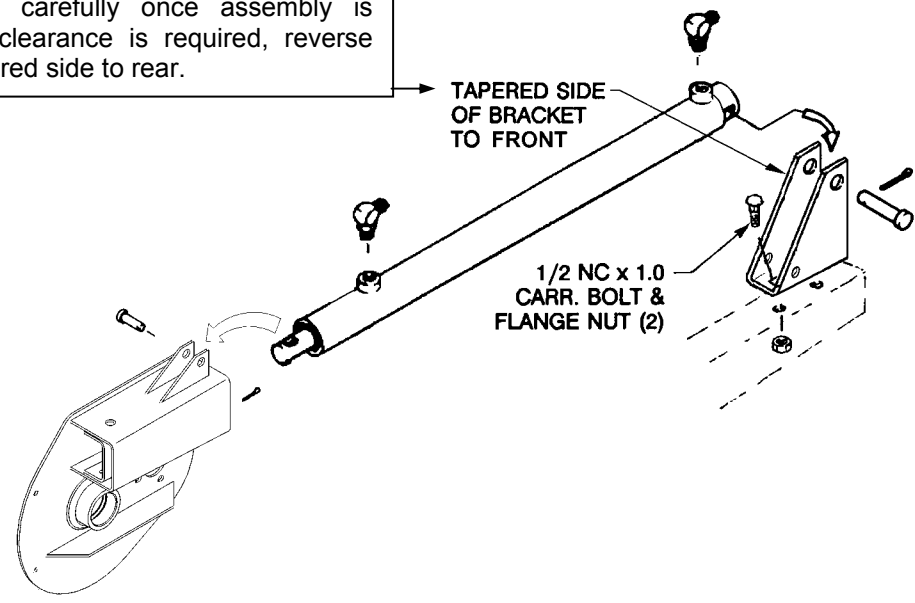

UNLOADING & ASSEMBLY HYDRAULIC REEL FORE-AFT KIT INSTALLATION INSTRUCTIONS

2. Attach cylinder(s) at:
- L/H reel support arm (30' Header)
 - L/H and R/H reel support arms (36' Header) - L/H shown

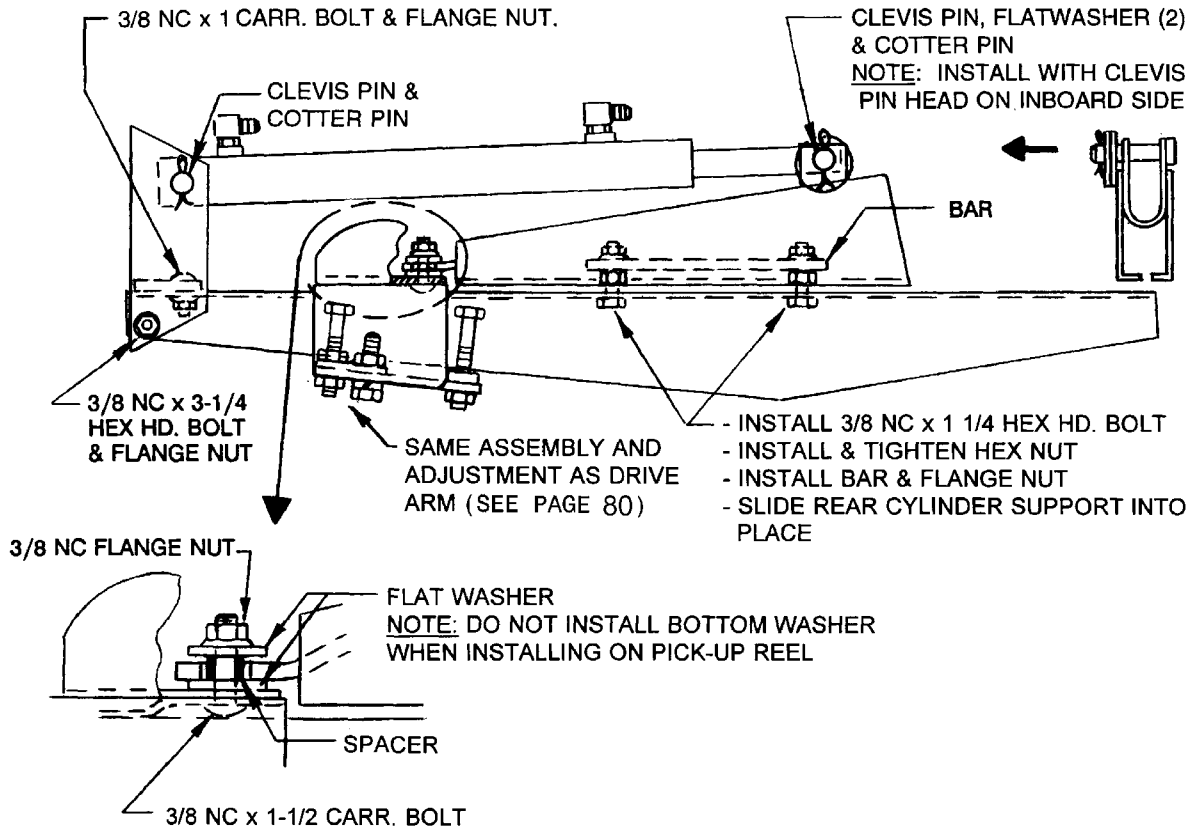

UNLOADING & ASSEMBLY HYDRAULIC REEL FORE-AFT KIT INSTALLATION INSTRUCTIONS

3. Connect hoses (30' Header):

IMPORTANT: To prevent damage to fore-aft kit and/or reel, before moving reel with fore-aft kit:

- a) Remove cylinder pins at rod ends and support cylinders to allow unobstructed movement of cylinder rods.
- b) Activate hydraulics, extending and retracting cylinders several times to fill system with oil and ensure cylinders are in phase.
- c) Reconnect cylinder rod ends.



WARNING: Never connect the fore-aft couplers to each other. This would complete the circuit and allow the reel to slide unexpectedly.

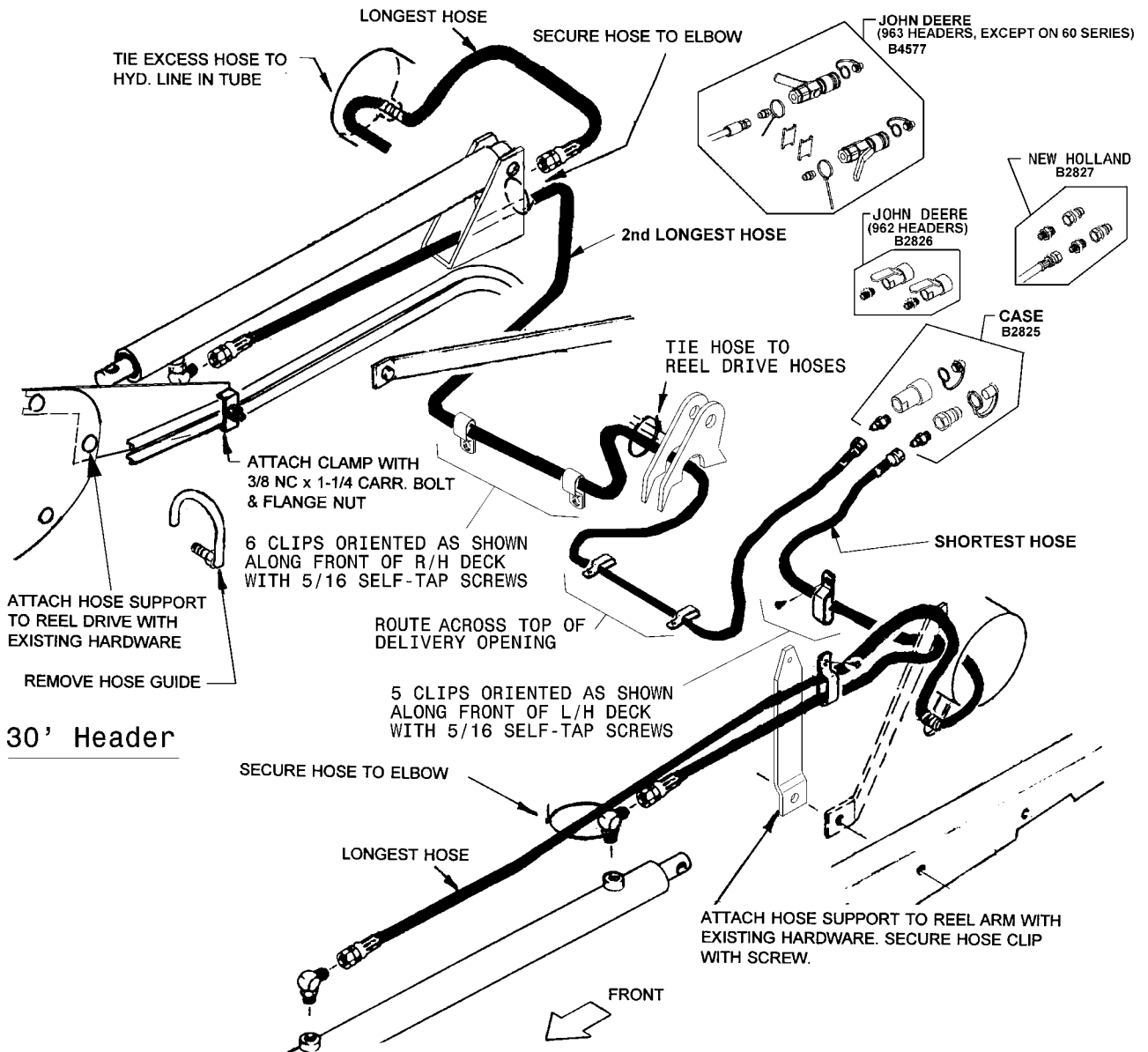

IMPORTANT: To prevent damage to reel from contact with diagonal brace, do not turn reel when it is positioned fully back for transport.

UNLOADING & ASSEMBLY HYDRAULIC REEL FORE-AFT KIT INSTALLATION INSTRUCTIONS

3. Connect hoses (36' Header):

IMPORTANT: To prevent damage to fore-aft kit and/or reel, before moving reel with fore-aft kit:

- a) Remove cylinder pins at rod ends and support cylinders to allow unobstructed movement of cylinder rods.
- b) Activate hydraulics, extending and retracting cylinders several times to fill system with oil and ensure cylinders are in phase.
- c) Reconnect cylinder rod ends.



WARNING: Never connect the fore-aft couplers to each other. This would complete the circuit and allow the reel to slide unexpectedly.

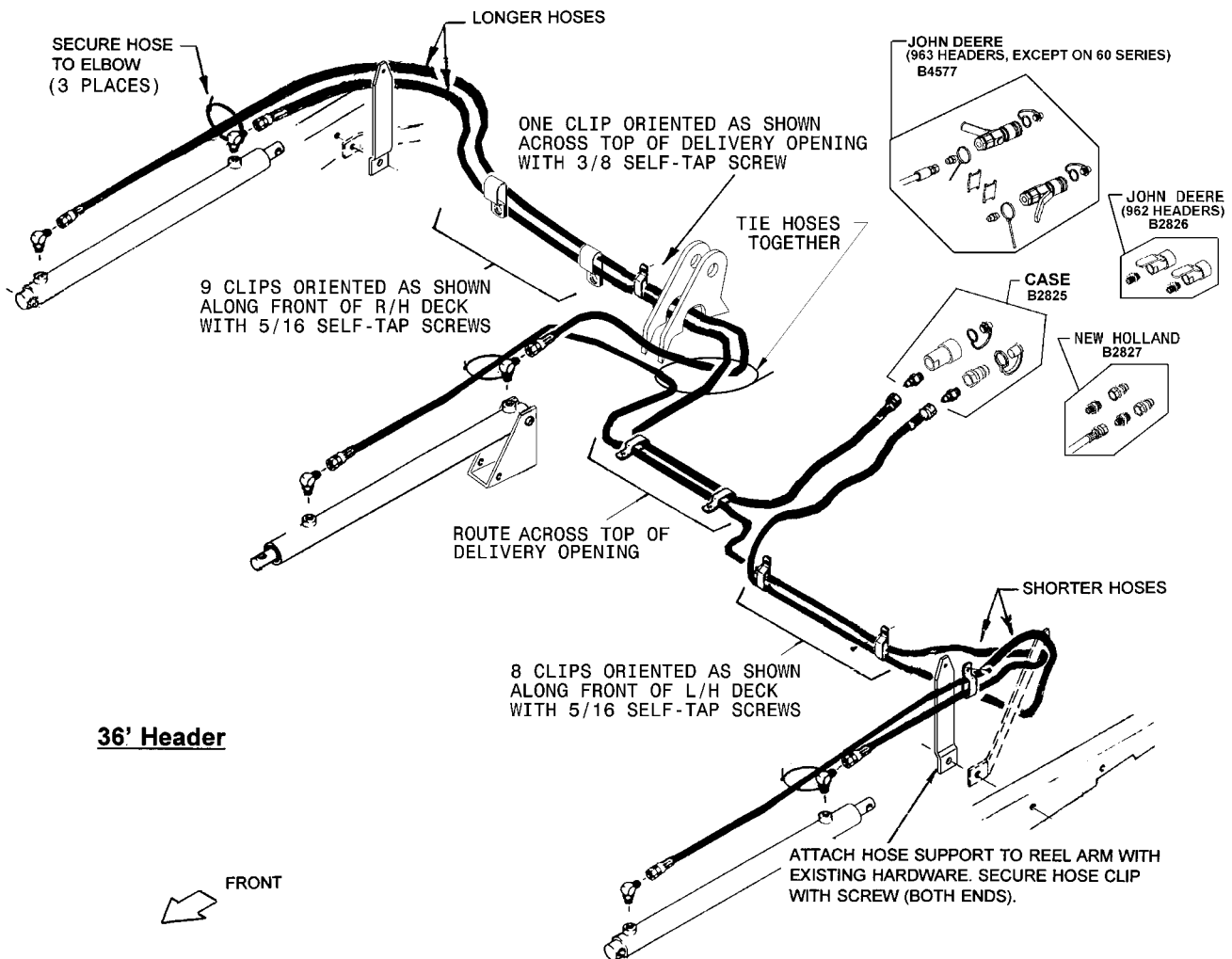

IMPORTANT: To prevent damage to reel from contact with diagonal brace, do not turn reel when it is positioned fully back for transport.

INDEX

<u>A</u>	PAGE
Assembly	63

<u>B</u>	
Bearing Installation	38
Break-In Period	13

<u>C</u>	
Capacities, Enclosed Drive	38
Cutting Height.....	19

<u>D</u>	
Delivery Opening Width Adjustment	21
Divider Angle	26
Draper Motors - Moving Inboard/Outboard ...	78
Draper Replacement	48
Draper Roller Maintenance	49
Draper Front Edge Seals.....	49
Draper Speed	21
Draper Tension Adjustment.....	48

<u>E</u>	
Electrical Schematic	42
End Delivery	24

<u>G</u>	
Gauge Wheels - Maintenance	51
Gauge Wheel Field Positions	18
Gauge Wheel/Transport Option	32
Greasing the Header	39
Ground Speed	17
Guards, Sickle	46

<u>H</u>	
Header Angle	21
Header Controls	16
Header Flotation	20
Header Lift Cylinder Stops	16
Hydraulic Hoses and Lines.....	41
Hydraulic Reel Fore-Aft Kit (Attachment)	61
Hydraulic Schematic.....	42
Hydraulic System Safety	41

<u>L</u>	PAGE
Lubricants, recommended.....	38

<u>M</u>	
Maintenance Record	54
Maintenance Schedule	53

<u>O</u>	
Operating Variables	17
Options/Attachments.....	60
Owner/Operator Responsibilities	12

<u>P</u>	
Pick-Up Reel (Option)	60
Pre-Starting Checks- Annual	14
Pre-Starting Checks- Daily.....	14

<u>R</u>	
Reel Arm Slope Enhancement Kit (Att.).....	61
Reel Centering in Header	50
Reel Clearance from Cutterbar	50
Reel Drive Chain	51
Reel Height	25
Reel Position - Fore & Aft	25
Reel Position (Hydraulic Attachment)	61
Reel Props	16
Reel Speed	25

<u>S</u>	
Safety	
Alert Symbol	4
General Farm.....	7
Header Lift Cylinder Stops	16
Hydraulic System	41
Operating	15
Pre-Starting Checks- Annual	14
Pre-Starting Checks- Daily	14
Reel Props	16
Service Procedures	37
Shut-Down Procedure	26
Signal Words	5
Signs.....	6
Storage Procedure.....	36
Tires.....	52
Transporting.....	31
Your Responsibilities	12

INDEX

S (continued)

	PAGE
Serial Number Location	4
Service Procedures	37
Shield, L/H - Closing.....	37
Shut-Down Procedure	26
Sickle Drive Assembly Conversion.....	76
Sickle Drive Belt Tension	47
Sickle Guards and Hold-Downs	46
Sickle Head Needle Bearing Installation	45
Sickle Lubrication	43
Sickle Removal and Installation	44,45
Sickle Sections	44
Sickle Storage	45
Skid Shoes	19
Specifications - Header	9
Specifications - Torque Values.....	10
Storage Procedure	36

I

Tire Inflation & Maintenance.....	52
Torque Specifications.....	10
Transport Option	
Attaching to Towing Vehicle.....	34
Converting from Field to Transport	32
Converting from Transport to Field	35
Towing the Header.....	34
Transporting the Header	
on Windrower/Combine.....	31
Trouble Shooting	
Crop Loss at Cutterbar	55
Cutting Components	55
Drapers	58
Reel	57
Windrow Formation	59

U

Unloading the Header	62
----------------------------	----

W

Wheel Bolts	51
Windrow Characteristics.....	29
Windrowing.....	27
Wobble Box	47

963 Harvest Header Pre-Delivery Checklist

HEADER: Serial Number _____

Perform these checks and adjustments prior to delivery to your customer. See the Operator's Manual for adjustment details.



CAUTION: Carefully follow the instructions given. Be alert for safety related messages which bring your attention to hazards and unsafe practices.

- Check for shipping damage or missing parts.
- Adjust bat reel fore-aft position to the 8th hole from the front.
- Adjust bat reel clearance from cutterbar. (2 inches [50 mm])
- Check sickle drive belt tension.
- Check tire pressure. (Units with gauge wheels.)
6.70-15 tire: 24 to 28 psi (165 to 195 kPa) 9.5L-14 tire: 42 to 46 psi (290 to 315 kPa)
- Check gauge wheel bolt torque. (Units with gauge wheels.)
6 bolt hub: 85 ft.lbs. (115 N·m) 4 bolt hub: 55 ft.lbs. (75 N·m)
- Select gauge wheel field position 2. (Units with gauge wheels.)
- Check header flotation. (50 to 70 lbs. [220 to 310 N])
- Check that header is level.
- Grease all bearings and drivelines.
- Reposition wobble box breather. (Unless transported upright on trailer).
- Check wobble box lube level.
- Straight Cut Only: Set header side drapers to an opening width that overlaps feeder pan deflectors by 1 inch (25 mm) minimum. See plasticized set up card provided with combine adapter.
- Check draper overlap (previous check) is consistent at left and right deck. Reposition left deck if necessary.
- Straight Cut Only: Adjust mechanical center link between header and adapter to have 1" (25 mm) exposed thread at each end.
- Check hydraulic hose and wiring harness routing, ensuring adequate clearance with header up or down. Be sure colour coding on hydraulic hoses is matched and that all hydraulic connections are fully engaged.
- Complete windrower or combine adapter Pre-delivery, then operate header with reel, drapers and sickle running slowly for 5 minutes.
- Bleed reel lift cylinder.
- Check draper tension.
- Run machine at operating speed for 15 minutes, STOP ENGINE and check for belt/idler alignment and heated bearings. Check sickle sections for discolouration caused by misalignment of components.
- Check lights are functional.

Date Checked: _____ Checked by: _____