

QUICK REFERENCE CARD: CAT LEXION 460 & 480 Series COMBINES

Combine Preparations

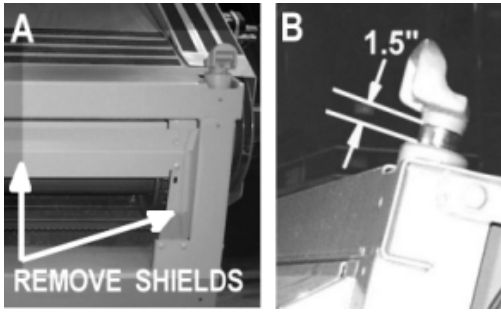

- Remove dust shields (3) from feeder house. **(Fig. A).**
- Ensure auto contour cylinders on the feeder house are level and showing about 1.5" (38mm) of the cylinder shaft. **(Fig. B).** For non-CAC feeder house, check dimension of top support. See Op Manual, page 64.

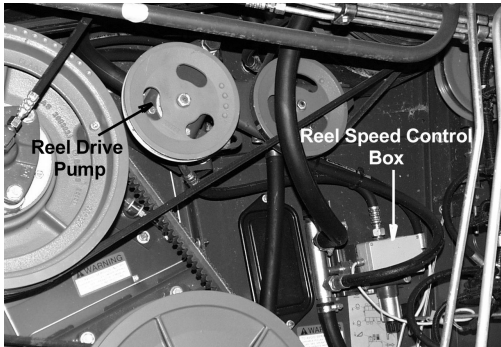

- Combine must be equipped with reel drive pump located on the L/H combine side panel.

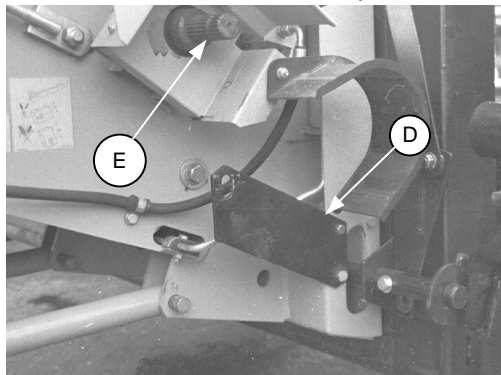

**INSTALL PUMP SUPPORT ARM &
SET VARIABLE SPEED TO 750 RPM**

- Install pump torque arm support (D) to right side of the feeder house.
- Set variable speed header drive to 750 rpm, measured at shaft (E).
- For CAC feeder houses, remove bars (G) at float slot, both sides. For non-CAC feeder houses, bars (G) are required.
- Set feeder house drum to grain position.
- Set feeder house lift cylinder springs to match weight of header.

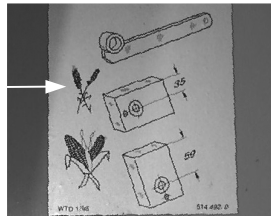

872 Combine Adapter

- Retracting tine drum on adapter is shipped in proper position for combines with dust shields removed. Dimension Y = 6.3" (160 mm)

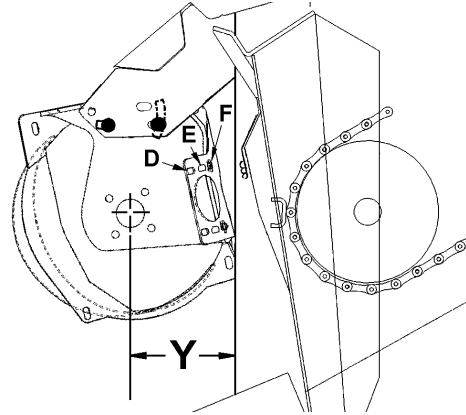

- Set the mechanical center link between the header and adapter to have 1" (2.5 cm) of thread showing from each end.

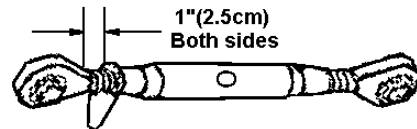

- Set the float to 70 – 100lbs at each crop divider. Use hook scale if necessary.
- The bolts that are used to lock out the float for shipping should now be used to fasten the adapter to the header. Pins with spring clips from the hardware package should be used to lock out the float **(during transport).**
- Set the adapter valve flow control to number "4"

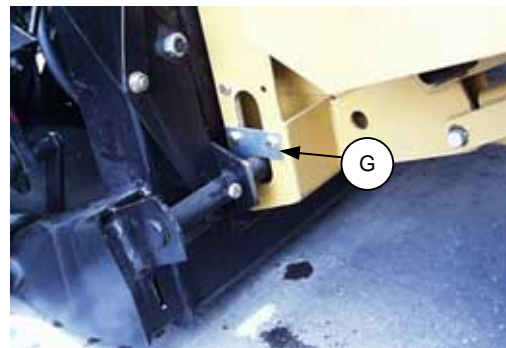
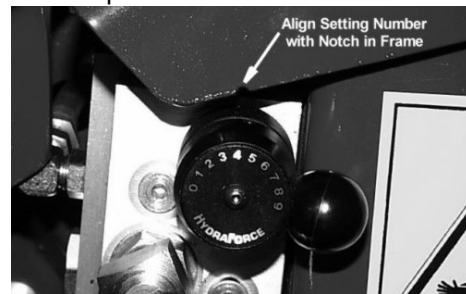

REMOVE BARS – C.A.C. FEEDER

QUICK REFERENCE CARD: CAT LEXION 460 & 480 Series COMBINES

REFER TO OPERATORS MANUAL FOR DETAILS ON THE FOLLOWING:

962

- ❑ Set the center delivery opening for all Caterpillar 460 & 480 Series combines to **58"** (1473mm). Cut drapers for the 59.5" (1510mm) opening, slide the left deck inward so it overlaps adapter side deflector by 2.5" (63mm). The right side will have a 1" (25mm) overlap.

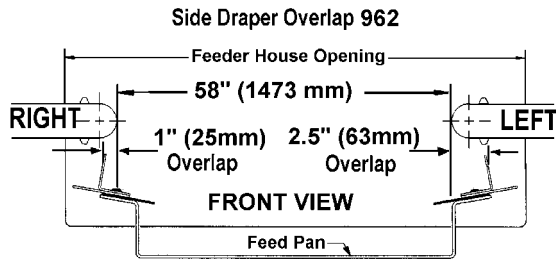

- ❑ Align the **rear** of the rear deflectors on the feed pan to the edge of the feeder house opening.
- ❑ Leave the draper seals in storage position. (Bolted on the back of the right panel on the 962).



- ❑ For crop stubble 8" (210mm) or less, set gauge wheels/transport to low pressure (field position "2").

2000B Pick Up Reel

- ❑ Set the cam arm in the "X" position.
- ❑ Install the bolt going through the cam arm from the inside out (head inboard).

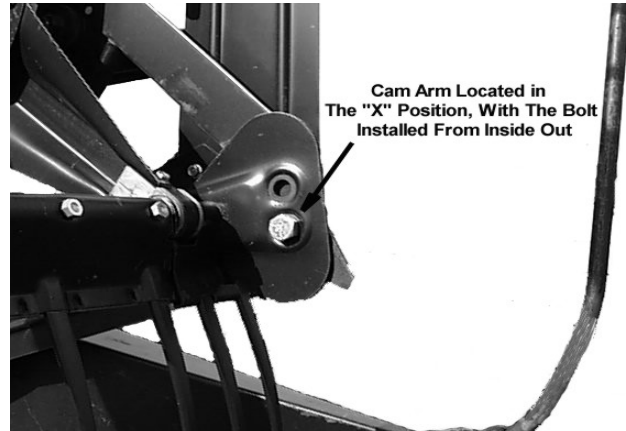

- ❑ Set the reel pitch in **L** or **M** and use range slot **P**. This adjustment is satisfactory for most crop conditions.

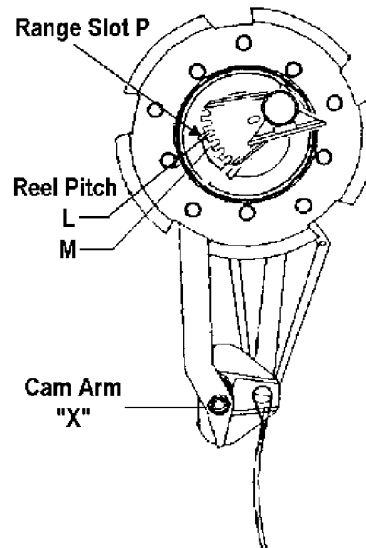

NOTE: Refer to the back side of this card or the Op Manual for further finger pitch adjustments.

- ❑ Set fore/aft position for the pick-up reel in the 5th hole, (bat reel 8th hole) from the front (crop end) of the reel arm.
- ❑ Set the clearance from the reel fingers to the cutterbar to a minimum of 2" (5cm) for a 30' header, and 1-1/2" (4cm) for 36' headers.
- ❑ Recommended reel speed is 10% above ground speed.

QUICK REFERENCE CARD: CAT LEXION 460 & 480 Series COMBINES

972

- ❑ Set the center delivery opening for all Caterpillar 460 & 480 Series combines to **57.5" (1460mm)**. Slide both decks over on the 972 so that there is a **2" (50mm)** overlap of adapter side deflectors per side.

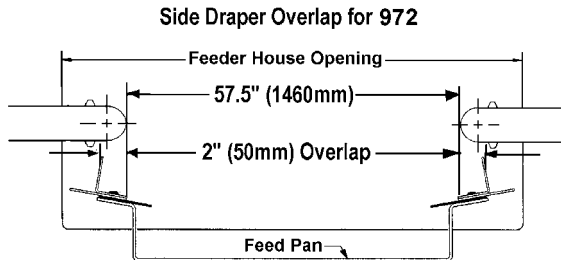

- ❑ Align the **rear** of the rear deflectors on the feed pan to the edge of the feeder house opening to ensure smooth crop flow into combine.

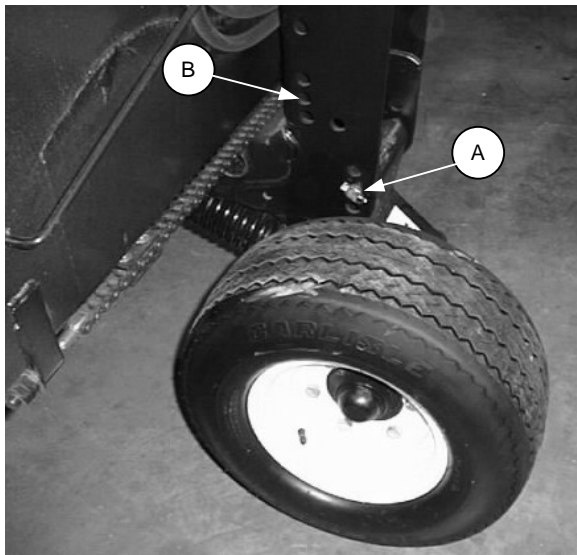

- ❑ Set gauge wheels/transport to "Middle" stubble height. For standard gauge wheels, use hole (A). For transport gauge wheels, use hole (B).

2100 Reel

- ❑ Install the bolt going through the cam arm with head **inboard** and torque to 120 ft. lbs. (162 N·m.).

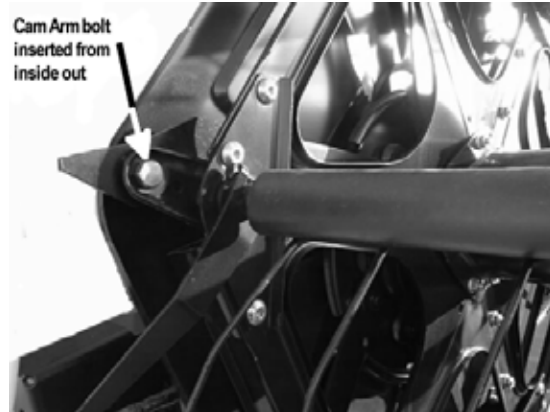

- ❑ Adjust finger pitch to position "5".

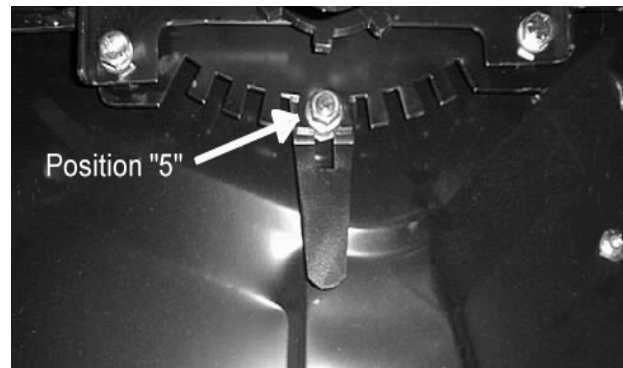

- ❑ Set the fore/aft adjustment in the 9th hole from the front (crop end) of the reel arms.
- ❑ Reel finger to sickle guard minimum clearance with reel fully lowered is 5/8" (15mm), **measured at both ends of the cutter bar.**
- ❑ Recommended reel speed is 10% above ground speed.

Bat Reel

- ❑ Refer to the Op Manual.

QUICK REFERENCE CARD: CAT LEXION 460 & 480 Series COMBINES

962/872 Initial Set-up, Average Cereal Crops	Field Peas		Edible Beans	
	Average Cereal Crops	Dry Conditions	Wet Condition	Dry Conditions
Sickle --Check daily that guards are aligned. Clearance from hold down to sickle .0020" (.05mm)	-	-	Stub guard kit is recommended.	Stub guard kit is recommended.
2000B Reel Fore/ Aft -5 th hole/frt. Cam Arm -Y Range Slot - P Finger Pitch - L or M Reel Clearance - 2" (50mm) Speed - +10% of ground speed	2 nd from front Y Q M 2" (50mm)	2 nd from front. Y P J 2" (50mm)	2 nd from front X P M 2" (50mm)	2 nd from front. X P M 2" (50mm)
Draper Speed - Dial position "4".	-	-	-	-
Draper opening - 58" (1473mm)	-	-	-	-
Guard Angle - 1.0" (25mm) of threads showing on center link. Poly Skids - None	- Yes	- Yes	Center link fully extended. Yes	Center link fully extended. Yes
Gauge Wheels (if equipped) - Most cereals require "position 2" stubble height setting	-	-	-	-
Float - Adjust float in the range of 70 –100 lbs. at cutter bar end.	70 – 100 lbs.	150 – 200 lbs.	150 – 200 lbs.	70 – 100 lbs.

972/872 Initial Set-up, for Average Cereal Crops	Rice		Edible Beans	
	Average Cereal Crops	Normal Cutting	Tough Cutting	Dry Conditions
Sickle --Check daily that guards are aligned. Clearance from hold down to sickle .020" (.05mm)	Stub Guard Kit is recommended.	Stub Guard Kit is recommended.	Stub Guard Kit is recommended.	Stub Guard Kit is recommended.
2100 reel Fore/Aft - 9 th hole/front Finger Pitch Adjustment - Slot 5 Reel Clearance - 5/8" (15mm) Speed - +10 % ground speed.	8 th from front - - -	6 th from front - - -	7 th from front Slot 7 ½" (13mm)	7 th from front Slot 7 ½" (13mm)
Draper Speed - Dial position "4".	Dial position "4"	Position"3,4"	-	-
Draper opening - 57.5" (1460mm)	-	61" (1549mm)	-	-
Guard Angle - 1.0" (25mm) of threads showing on center link. Poly Skids - None	- Yes	- Yes	Center link fully extended. Yes	Center link fully extended. Yes
Gauge Wheels (if equipped) - Most cereals require "medium" stubble height setting.	Not Applicable	Not Applicable	Short	Short
Float - Adjust float in the range of 70 - 100lbs. at cutter bar end.	100 – 130lbs.	100 – 130 lbs.	150 – 200 lbs.	70 – 100 lbs.