

Recommended Fluids and Lubricants

Ensure your machine operates at top efficiency by using clean fluids and lubricants only.

- Use clean containers to handle all fluids and lubricants.
- Store fluids and lubricants in an area protected from dust, moisture, and other contaminants.

Lubricant	Specification	Description	Use	Capacities
Grease	SAE multi-purpose	High temperature extreme pressure (EP) performance grease with 1% max Molybdenum Disulphide (NLGI Grade 2) lithium base	As required unless otherwise specified	—
		High temperature extreme pressure (EP) performance grease with 10% max Molybdenum Disulphide (NLGI Grade 2) lithium base	Driveline slip-joints	—
Gear Lubricant	SAE 85W-140	API service class GL-5	Knife drive box	1.5 liters (1.3 quarts)
			Main drive gearbox	1.5 liters (1.3 quarts)
			Completion gearbox	1.5 liters (1.3 quarts)
Hydraulic Oil	Single grade trans-hydraulic oil Recommended viscosity: • 60.1 cST @ 40°C • 9.5 cST @ 100°C Recommended brands: • Petro-Canada Duratran • John Deere Hy-Gard J20C • Case Hy-Tran Ultraction • AGCO Power Fluid 821 XL	Lubricant trans / hydraulic oil	Header drive systems reservoir	95 liters (25.1 US gallons)

Break-In Inspections

To help avoid major component service or replacement, perform break-in inspections on your machine for the first 50 hours of operation. Refer to your operator's manual for complete break-in inspection and adjustment procedures.

Inspection Instance	Item
First 5 Minutes	Check hydraulic oil level in reservoir (check after first run-up and after the hydraulic hoses have filled with oil).
5 Hours	Check for loose hardware and tighten to required torque.
10 Hours	Check auger drive chain tension.
	Check knife drive box mounting bolts.
50 Hours	Change float module gearbox oil.
	Change float module hydraulic oil filter.
	Change knife drive box lubricant.
	Check gearbox chain tension.

Ongoing Maintenance Intervals

Refer to the operator's manual for a comprehensive maintenance schedule and record. Log hours of operation, use the maintenance record, and keep copies of your maintenance records.

Following the maintenance schedule will increase your machine's life.

Subject to change without notice

SETTING HEADER FLOAT AND WING BALANCE

Follow these five steps in order to set the header float and wing balance:

NOTE:

Read your operator's manual and complete all the setup tasks before setting the header float.

Step 1: Preadjustments

- Park combine on a level surface, and ensure the combine feeder house is level. Use bubble level on float module.
- Adjust header so cutterbar is 250 mm (10 in.) (A) off the ground.
- Set the header angle hydraulic cylinder to D on indicator (B).
- Set the reel fore-aft to 6 on reel arm fore-aft indicator (C).
- Lower the reel completely, shut down the combine, and remove key from the combine ignition.

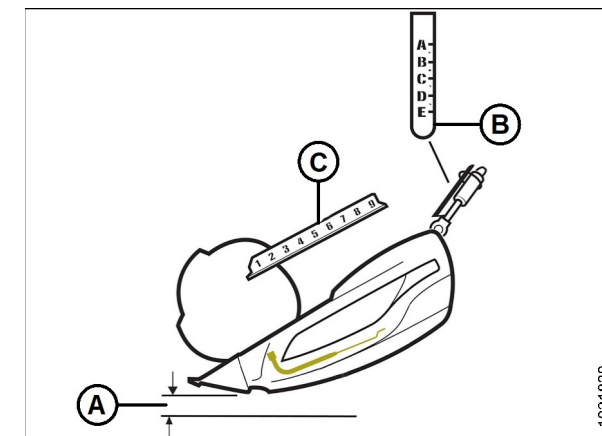

Figure 1: Header – Side View

- Remove linkage cover (A).
- Place both left and right wing lock spring handle (B) in the locked (upper) position. You should hear the lock engaged. If not, move the wings up and down, so that the lock engages.

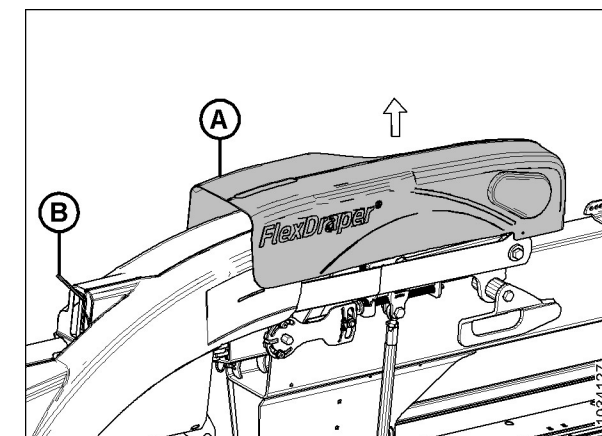

Figure 2: Wing Lock Spring Handle in Locked Position – Left Side Shown

- Place both left and right header float locks in unlocked (lowered) position (A).
- Set stabilizer/transport wheels or contour wheels (if equipped) to upper most position.

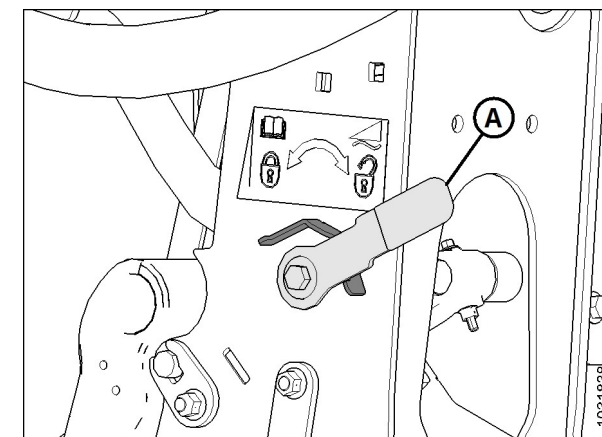

Figure 3: Float Unlocked – Left Side Shown

Step 2: Checking Header Float

NOTE: Oil reservoir tank made transparent in Figure 4 to show tool engaged on the float setting lever at the front of the header.

- Lift float setting lever (A) by hand to remove any slack.
- Place tool (B) on the float setting lever. The tool should be slightly angled towards the front of the header.
- Pull down on tool (B) towards the back of the header until lever (A) is over center and will not return to its original position. Remove the tool and repeat on the opposite side. It is important that float setting levers on both sides are engaged while adjusting.
- On the side that you are adjusting, move header up and down by hand, and release to reduce the effect of friction.

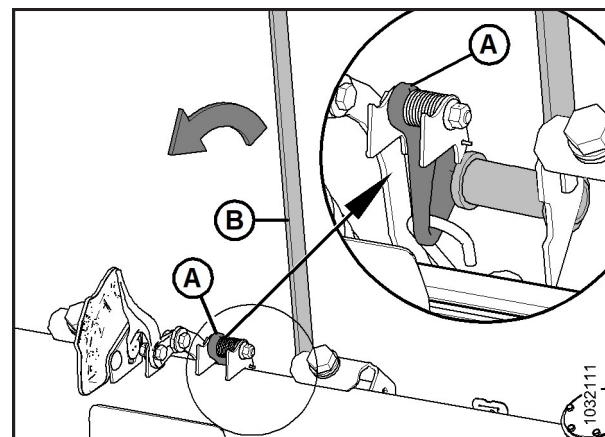

Figure 4: Checking Float – Left Side Shown, View from Rear

- Check the numbers in small print (A) on float setting indicator (FSI) is for the current float value. The pointer arm (B) on the FSI should be on number 2.

- If the reading on FSI is higher than 2, the header is heavy.
- If the reading on FSI is lower than 2, the header is light.

NOTE: The numbers in large print (B) are for the float height indicator and used when operating the header in the field.

NOTE:

If necessary, set float values to suit crop and field conditions. For more information, refer to the header operator's manual.

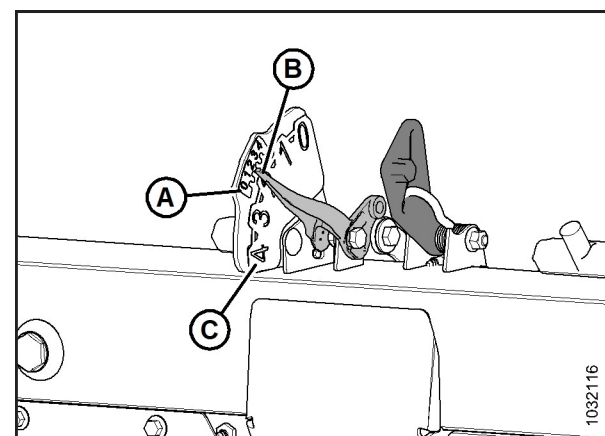

Figure 5: Checking Float – Left Side Shown, View from Rear

Step 3: Setting Header Float

- Loosen bolts (C), and rotate spring locks (B).
 - To decrease header weight, turn both adjustment bolts (A) clockwise (decrease number on float setting indicator [FSI]).
 - To increase header weight, turn both adjustment bolts (A) counterclockwise (increase number on FSI).
- NOTE:** Ensure float setting indicator readings are equal on both sides of the float module.
- Lift end of header by hand after adjusting and recheck reading.
 - Once complete, use the tool and return the float setting lever to its original location.

NOTE: If adequate header float cannot be achieved using all the available adjustments, an optional heavy duty spring is available. See your MacDon Dealer or refer to the parts catalog for ordering information.

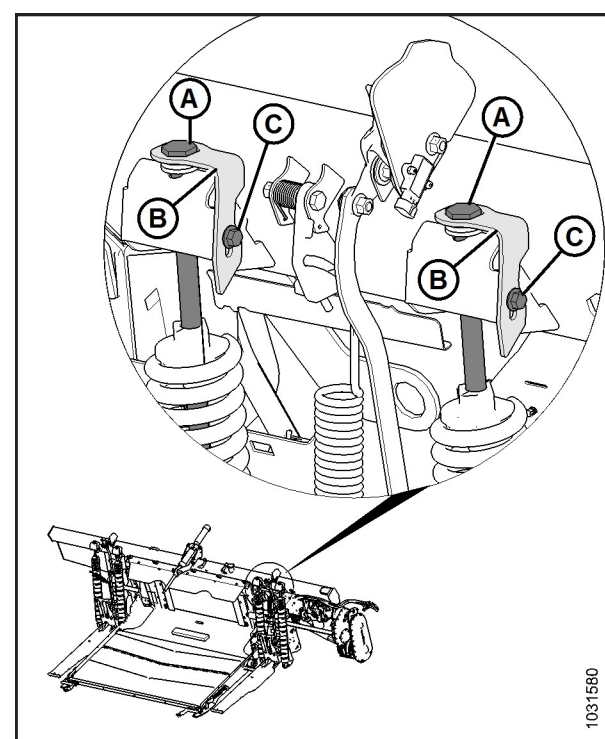

Figure 6: Float Adjustment Bolts – Left Side Shown

Step 4: Checking Wing Balance

NOTE: Before proceeding, the header float must be set properly. Refer to Step 3: Setting Header Float.

- Attach flex checker cable (A) to flex checker cable lock (B).

NOTE: Images shown are from the left side.

- Move spring handle (A) on the side that you are adjusting to the lower (UNLOCK) position. You should hear the lock disengaged. If not, use tool (B) to rotate mechanism so that the lock disengages.

NOTE: Keep the opposite wing locked.

- On flex checker plate, pinch indicators (A) and (B) together with your fingers.
- Use tool (C) to rotate flex checker plate up until pin reaches the end of slot. The lower indicator (B) will move down to give the first reading.
- Use tool (C) to rotate flex checker plate down until pin reaches the end of slot. The upper indicator (A) will move up to give the second reading.

- Repeat Steps c and d.

- Refer to Figure 10 and compare the two readings as follows:

- Condition A – the wing is too light; make wing heavier.
- Condition B – the wing is too heavy; make wing lighter.
- Condition C – wing balance correctly adjusted. Reinstall the linkage cover, and repeat the procedure on the opposite wing.

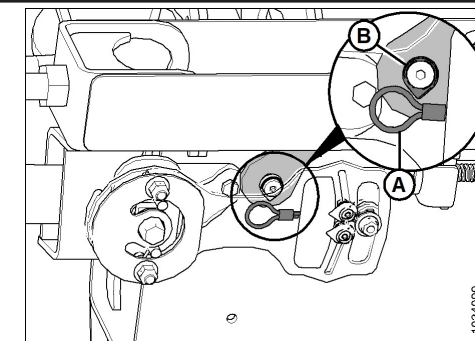

Figure 7: Flex Checker Cable

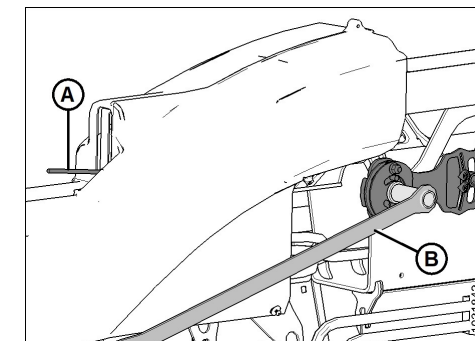

Figure 8: Wing Balance Linkage

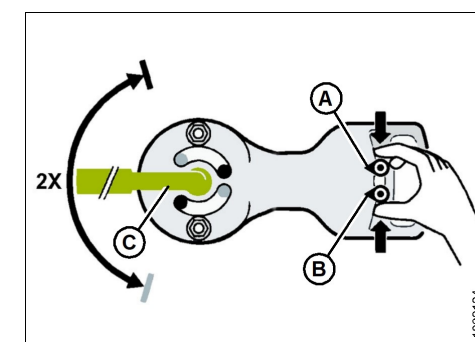

Figure 9: Wing Balance Adjustment

Step 5: Adjusting Wing Balance

- If the wing is too light (Condition A), make it heavier by turning adjuster bolt (A) to move clevis (B) in direction (C).
- If the wing is too heavy (Condition B), make it lighter by turning adjuster bolt (A) to move clevis (B) in direction (D).
- Recheck wing balance. Adjust as required until wing is balanced (Condition C).
- Move the spring handle to the upper (LOCK) position.
- If the lock does not engage, move the wing up and down with tool until it locks.
- Detach the flex checker cable from the flex checker lock.
- Repeat on the other side.
- Return the tool to its storage location, and reinstall the linkage cover.

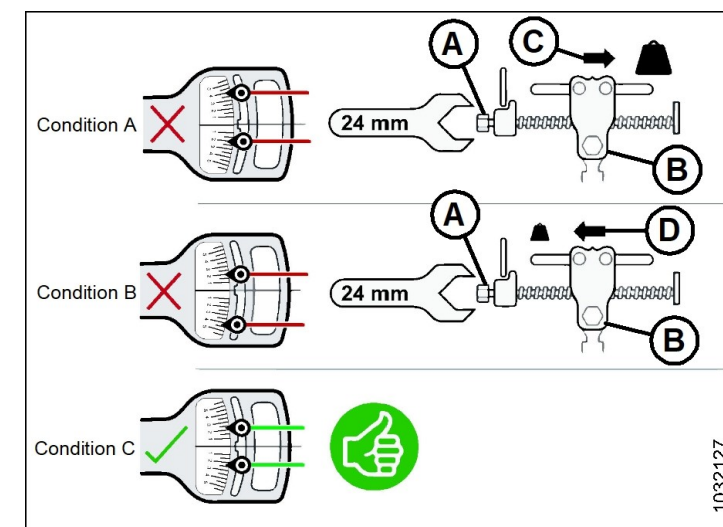

Figure 10: Wing Balance Adjustment