

MacDon™

**Model D65 Harvest Header®
with
CA25 Combine Adapter**

**UNLOADING and
ASSEMBLY INSTRUCTIONS
for
NORTH AMERICAN SHIPMENTS**

INTRODUCTION

This instructional manual describes the unloading, set-up and pre-delivery requirements for the MacDon D65 Harvest Header[®] with a CA25 Combine Adapter for North America.

Use the Table of Contents to guide you to specific areas.

Retain this instruction for future reference.

CAREFULLY READ ALL THE MATERIAL PROVIDED BEFORE ATTEMPTING TO UNLOAD, ASSEMBLE, OR USE THE MACHINE.



MACDON D65 HARVEST HEADER[®] WITH CA25 ADAPTER

CONTENTS

GENERAL SAFETY	3
RECOMMENDED TORQUES	5
A. General.....	5
B. SAE Bolts	5
C. Metric Bolts.....	5
D. Hydraulic Fittings.....	6
CONVERSION CHART	8
STEP 1. UNLOAD HEADER	9
STEP 2. LOWER HEADER	10
STEP 3. REMOVE SHIPPING STANDS	11
STEP 4. INSTALL REEL LIFT CYLINDERS.....	12
STEP 5. RE-POSITION GEARBOX	15
STEP 6A. INSTALL REEL SPEED SENSOR: HI-TORQUE SINGLE & DUAL REEL.....	16
A. Remove Cover	16
B. John Deere Sensor Installation	18
C. CAT Lexion 500 and 700 Series Sensor Installation	20
D. AGCO Sensor Installation.....	22
E. Install Cover	23
STEP 6B. INSTALL REEL SPEED SENSOR: SINGLE REEL, STD TORQUE.....	24
A. Remove Cover	24
B. John Deere Sensor Installation	25
C. CAT Lexion 500 and 700 Series Sensor Installation	26
D. AGCO Sensor Installation.....	27
E. Install Cover	28
STEP 7. INSTALL OPTIONS.....	28
STEP 8. SET-UP ADAPTER	29
A. Filler Cap.....	29
B. Flighting Extensions	30
C. Stripper Bars	30
D. CR Feeder Deflectors	31
STEP 9. ATTACH TO COMBINE	32
A. CASE IH 7010, 8010, 7120, 8120, 5088, 6088, 7088	32
B. John Deere 60, 70 Series	35
I. Install Reel Fore-Aft / Header Tilt Switch	35
II. Attach Header	37
C. CAT Lexion 500, 700 Series	39
D. New Holland CR, CX Series	41
E. AGCO.....	44
STEP 10. ATTACH CAM ARMS	47
STEP 11. REMOVE SHIPPING SUPPORTS	48
STEP 12. POSITION TRANSPORT LIGHTS	48
STEP 13. INSTALL CROP DIVIDERS	49

CONTENTS

STEP 14.	TRIM DRAPER DEFLECTORS	50
STEP 15.	PRE-DELIVERY CHECKS.....	51
A.	Tire Pressure: Transport and Stabilizer Wheel Options	51
B.	Wheel Bolt Torque: Transport and Stabilizer Wheel Options.....	51
C.	Wobble Box	52
D.	Gearbox Oil.....	52
E.	Hydraulic Reservoir	53
F.	Sickle Belt Tension	54
I.	Non-Timed Drive: SK and DK.....	54
II.	Timed Drive: DK	54
G.	Reel Centering.....	56
I.	Dual Reel	56
II.	Single Reel	56
H.	Side Draper Tension.....	57
I.	Check Header Float.....	58
J.	Skid Shoe Settings	60
K.	Reel Tine to Cutterbar Clearance.....	61
L.	Draper Seal.....	63
M.	Lubricate Header	64
N.	Endshields	69
O.	Operator's Manual and Parts Catalogs	70
STEP 16.	RUN-UP THE HEADER	71
STEP 17.	POST RUN-UP ADJUSTMENTS.....	73
A.	Knife.....	73
B.	Knife Speed	74

GENERAL SAFETY



CAUTION

- The following are general farm safety precautions that should be part of your operating procedure for all types of machinery.
- Protect yourself.
- When assembling, operating and servicing machinery, wear all the protective clothing and personal safety devices that **COULD** be necessary for the job at hand. Don't take chances.
- You may need:

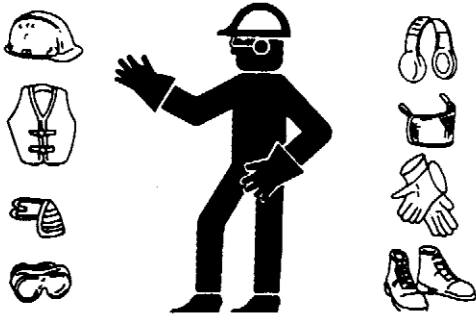

- a hard hat.
- protective shoes with slip resistant soles.
- protective glasses or goggles.
- heavy gloves.
- wet weather gear.
- respirator or filter mask.

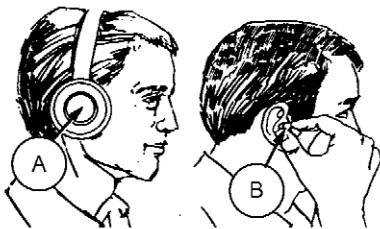

- hearing protection. Be aware that prolonged exposure to loud noise can cause impairment or loss of hearing. Wearing a suitable hearing protective device such as ear muffs (A) or ear plugs (B) protects against objectionable or loud noises.

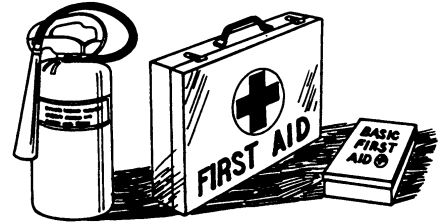

- a first-aid kit for use in case of emergencies.
- Keep a fire extinguisher on the machine. Be sure the extinguisher is properly maintained and be familiar with its proper use.
- Keep young children away from machinery at all times.
- Be aware that accidents often happen when the Operator is tired or in a hurry to get finished. Take the time to consider the safest way. Never ignore warning signs of fatigue.
- Wear close-fitting clothing and cover long hair.
- Never wear dangling items such as scarves or bracelets.
- Keep hands, feet, clothing and hair away from moving parts. Never attempt to clear obstructions or objects from a machine while the engine is running.

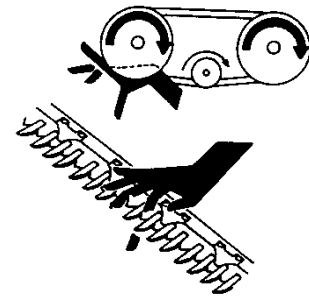

- Keep all shields in place. Never alter or remove safety equipment. Make sure driveline guards can rotate independently of the shaft and can telescope freely.
- Use only service and repair parts made or approved by the equipment manufacturer. Substituted parts may not meet strength, design or safety requirements.

(continued next page)

SAFETY

- Do not modify the machine. Unauthorized modifications may impair the function and/or safety and affect machine life.
- Stop engine, and remove key from ignition before leaving Operator's seat for any reason. A child or even a pet could engage an idling machine.



- Keep the area used for servicing machinery clean and dry. Wet or oily floors are slippery. Wet spots can be dangerous when working with electrical equipment. Be sure all electrical outlets and tools are properly grounded.
- Use adequate light for the job at hand.
- Keep machinery clean. Do not allow oil or grease to accumulate on service platforms, ladders or controls. Clean machines before storage.
- Never use gasoline, naphtha or any volatile material for cleaning purposes. These materials may be toxic and/or flammable.
- When storing machinery, cover sharp or extending components to prevent injury from accidental contact.

RECOMMENDED TORQUES

RECOMMENDED TORQUES

A. GENERAL

The tables shown below give correct torque values for various bolts and capscrews.

- Tighten all bolts to the torques specified in chart unless otherwise noted throughout this manual.
- Check tightness of bolts periodically, using bolt torque chart as a guide.
- Replace hardware with the same strength bolt.
- Torque figures are valid for non-greased or non-oiled threads and heads unless otherwise specified. Do not grease or oil bolts or capscrews unless specified in this manual.
- When using locking elements, increase torque values by 5%.

B. SAE BOLTS

BOLT DIA. "A" (in.)	NC BOLT TORQUE*			
	SAE-5		SAE-8	
	ft·lbf	N·m	ft·lbf	N·m
1/4	9	12	11	15
5/16	18	24	25	34
3/8	32	43	41	56
7/16	50	68	70	95
1/2	75	102	105	142
9/16	110	149	149	202
5/8	150	203	200	271
3/4	265	359	365	495
7/8	420	569	600	813
1	640	867	890	1205

* Torque categories for bolts and capscrews are identified by their head markings.

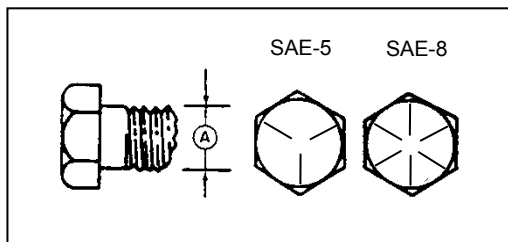

C. METRIC BOLTS

BOLT DIA. "A"	STD COARSE BOLT TORQUE*			
	8.8		10.9	
	ft·lbf	N·m	ft·lbf	N·m
M3	0.4	0.5	1.3	1.8
M4	2.2	3	3.3	4.5
M5	4	6	7	9
M6	7	10	11	15
M8	18	25	26	35
M10	37	50	52	70
M12	66	90	92	125
M14	103	140	148	200
M16	166	225	229	310
M20	321	435	450	610
M24	553	750	774	1050
M30	1103	1495	1550	2100
M36	1917	2600	2710	3675

* Torque categories for bolts and capscrews are identified by their head markings.

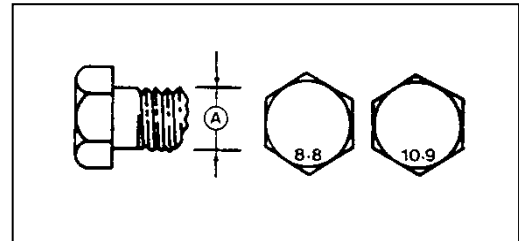

RECOMMENDED TORQUES

D. HYDRAULIC FITTINGS

FLARE TYPE

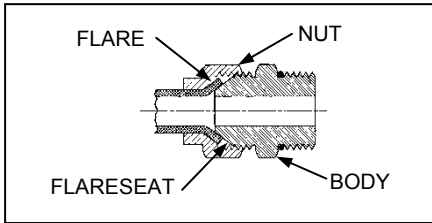

- Check flare and flare seat for defects that might cause leakage.
- Align tube with fitting before tightening.
- Lubricate connection, and hand-tighten swivel nut until snug.
- To prevent twisting the tube(s), use two wrenches. Place one wrench on the connector body, and with the second, tighten the swivel nut to the torque shown.

SAE NO.	TUBE SIZE O.D. (in.)	THD SIZE (in.)	NUT SIZE ACROSS FLATS (in.)	TORQUE VALUE*		RECOMMENDED TURNS TO TIGHTEN (AFTER FINGER TIGHTENING)	
				ft·lbf	N·m	Flats	Turns
3	3/16	3/8	7/16	6	8	1	1/6
4	1/4	7/16	9/16	9	12	1	1/6
5	5/16	1/2	5/8	12	16	1	1/6
6	3/8	9/16	11/16	18	24	1	1/6
8	1/2	3/4	7/8	34	46	1	1/6
10	5/8	7/8	1	46	62	1	1/6
12	3/4	1-1/16	1-1/4	75	102	3/4	1/8
14	7/8	1-3/8	1-3/8	90	122	3/4	1/8

* Torque values shown are based on lubricated connections as in re-assembly.

O-RING TYPE

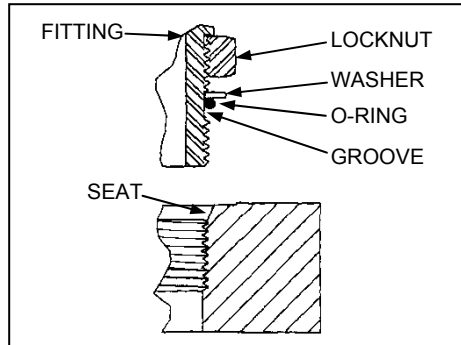

- Inspect O-ring and seat for dirt or obvious defects.

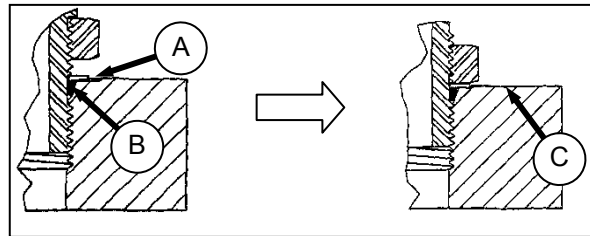

- On angle fittings, back off the lock nut until washer (A) bottoms out at top of groove (B) in fitting.
- Hand-tighten fitting until back up washer (A) or washer face (if straight fitting) bottoms on part face (C), and O-ring is seated.
- Position angle fittings by unscrewing **no more than one turn**.
- Tighten straight fittings to torque shown.
- Tighten angle fittings to torque shown in the following table, while holding body of fitting with a wrench.

SAE NO.	THD SIZE (in.)	NUT SIZE ACROSS FLATS (in.)	TORQUE VALUE*		RECOMMENDED TURNS TO TIGHTEN (AFTER FINGER TIGHTENING)	
			ft·lbf	N·m	Flats	Turns
3	3/8	1/2	6	8	2	1/3
4	7/16	9/16	9	12	2	1/3
5	1/2	5/8	12	16	2	1/3
6	9/16	11/16	18	24	2	1/3
8	3/4	7/8	34	46	2	1/3
10	7/8	1	46	62	1-1/2	1/4
12	1-1/16	1-1/4	75	102	1	1/6
14	1-3/16	1-3/8	90	122	1	1/6
16	1-5/16	1-1/2	105	142	3/4	1/8
20	1-5/8	1-7/8	140	190	3/4	1/8
24	1-7/8	2-1/8	160	217	1/2	1/12

* Torque values shown are based on lubricated connections as in re-assembly.

RECOMMENDED TORQUES

O-RING FACE SEAL (ORFS) TYPE HYDRAULIC FITTINGS

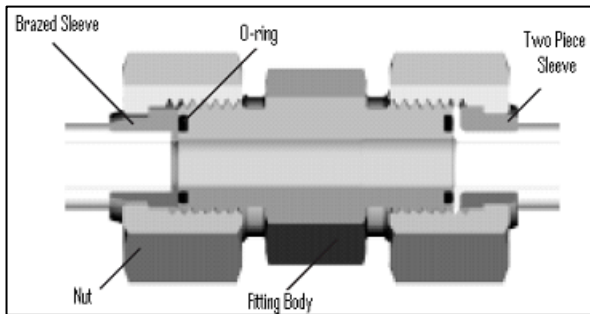
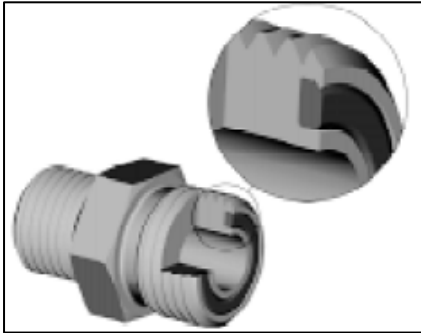

- a. Check components to ensure that the sealing surfaces and fitting threads are free of burrs, nicks, and scratches, or any foreign material.
- b. Apply lubricant (typically Petroleum Jelly) to O-ring and threads. If O-ring is not already installed, install O-ring. Align the tube or hose assembly.
- c. Ensure that flat face of the mating flange comes in full contact with O-ring.
- d. Thread tube or hose nut until hand-tight. The nut should turn freely until it is bottomed out. Torque fitting further to the specified number of F.F.F.T (“Flats From Finger Tight”), or to a given torque value in the table shown in the opposite column.

NOTE

If available, always hold the hex on the fitting body to prevent unwanted rotation of fitting body and hose when tightening the fitting nut.

- e. When assembling unions or two hoses together, three wrenches will be required.

SAE NO.	THD SIZE (in.)	TUBE O.D. (in.)	TORQUE VALUE*		RECOMMENDED TURNS TO TIGHTEN (AFTER FINGER TIGHTENING)**	
			ft-lbf	N·m	Tube Nuts	Swivel & Hose
3	***	3/16	---	---	---	---
4	9/16	1/4	11 - 12	14 - 16	1/4 - 1/2	1/2 - 3/4
5	***	5/16	---	---	---	---
6	11/16	3/8	18 - 20	24 - 27	1/4 - 1/2	1/2 - 3/4
8	13/16	1/2	32 - 35	43 - 47		
10	1	5/8	45 - 51	60 - 68		
12	1-3/16	3/4	67 - 71	90 - 95		1/3 - 1/2
14	1-3/16	7/8	67 - 71	90 - 95		
16	1-7/16	1	93 - 100	125 - 135		
20	1-11/16	1-1/4	126 - 141	170 - 190		
24	2	1-1/2	148 - 167	200 - 225		
32	2-1/2	2	---	---	---	---

* Torque values and angles shown are based on lubricated connection, as in re-assembly.

** Always default to the torque value for evaluation of adequate torque.

*** O-ring face seal type end not defined for this tube size.

CONVERSION CHART

CONVERSION CHART

QUANTITY	INCH-POUND UNITS		FACTOR	SI UNITS (METRIC)	
	UNIT NAME	ABBR.		UNIT NAME	ABBR.
Area	acres	acres	$\times 0.4047 =$	hectares	ha
Flow	US gallons per minute	gpm	$\times 3.7854 =$	liters per minute	L/min
Force	pounds force	lbf	$\times 4.4482 =$	Newtons	N
Length	inch	in.	$\times 25.4 =$	millimeters	mm
	foot	ft	$\times 0.305 =$	meters	m
Power	horsepower	hp	$\times 0.7457 =$	kilowatts	kW
Pressure	pounds per square inch	psi	$\times 6.8948 =$	kilopascals	kPa
			$\times .00689 =$	megapascals	MPa
Torque	pound feet or foot pounds	lbf-ft or ft-lbf	$\times 1.3558 =$	newton meters	N·m
	pound inches or inch pounds	lbf-in. or in-lbf	$\times 0.1129 =$	newton meters	N·m
Temperature	degrees Fahrenheit	°F	$(°F - 32) \times 0.56 =$	Celsius	°C
Velocity	feet per minute	ft/min	$\times 0.3048 =$	meters per minute	m/min
	feet per second	ft/s	$\times 0.3048 =$	meters per second	m/s
	miles per hour	mph	$\times 1.6063 =$	kilometers per hour	km/h
Volume	US gallons	US gal.	$\times 3.7854 =$	liters	L
	ounces	oz.	$\times 29.5735 =$	milliliters	ml
	cubic inches	in. ³	$\times 16.3871 =$	cubic centimeters	cm ³ or cc
Weight	pounds	lb	$\times 0.4536 =$	kilograms	kg

UNLOADING AND ASSEMBLY

STEP 1. UNLOAD HEADER



CAUTION

To avoid injury to bystanders from being struck by machinery, do not allow persons to stand in unloading area.



CAUTION

Equipment used for unloading must meet or exceed the requirements specified below. Using inadequate equipment may result in chain breakage, vehicle tipping or machine damage.

LIFTING VEHICLE	
Minimum Lifting Capacity *	9000 lb (4082 kg)
Minimum Fork Length	78 in. (1981 mm)

* At 48 in. (1220 mm) from back end of forks.

IMPORTANT

Forklifts are normally rated for a load located 24 inches (610 mm) from back end of the forks.

To obtain forklift capacity at 48 inches (1220 mm), check with your forklift distributor.

- a. Move trailer into position, and block trailer wheels.
- b. Lower trailer storage stands.



CAUTION

Avoid lifting the second header and ensure the forks do not interfere with the shipping frame. If the forks contact the second header, damage to the headers may occur.

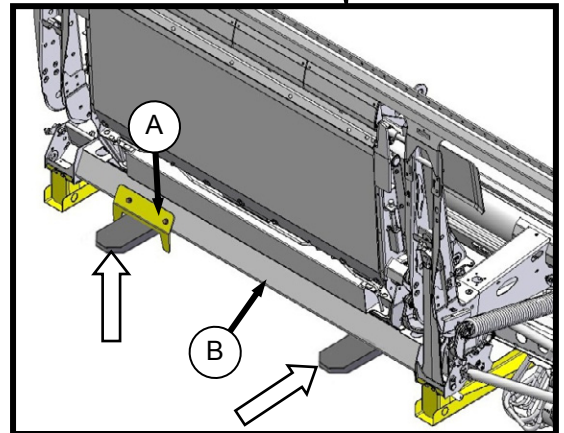

- c. Approach the header, and line up one fork with guide (A) under adapter frame.
- d. Slide forks underneath shipping support (B) of header as far as possible without contacting the shipping support of opposite header.
- e. Remove hauler's tie down straps and chains.



WARNING

Be sure forks are secure before moving away from load. Stand clear when lifting.

- f. Slowly raise header off deck.
- g. Back up until unit clears trailer, and slowly lower to 6 in. (150 mm) from ground.
- h. Take header to storage or set up area.
- i. Repeat above steps for second header.
- j. Check for shipping damage and missing parts.

UNLOADING AND ASSEMBLY

STEP 2. LOWER HEADER

Re-position header in preparation for assembly and set-up as follows:

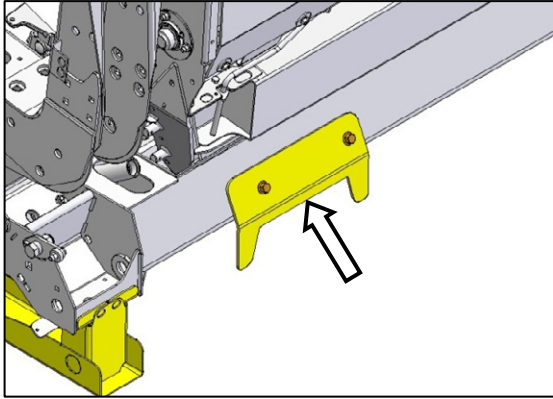

- Remove fork guide from adapter lower frame.
- Choose an area with level ground.
- Drive lifting vehicle to approach header from its underside.

IMPORTANT

Do not lift at cutterbar when unloading from trailer. This procedure is only for laying the machine over into working position.

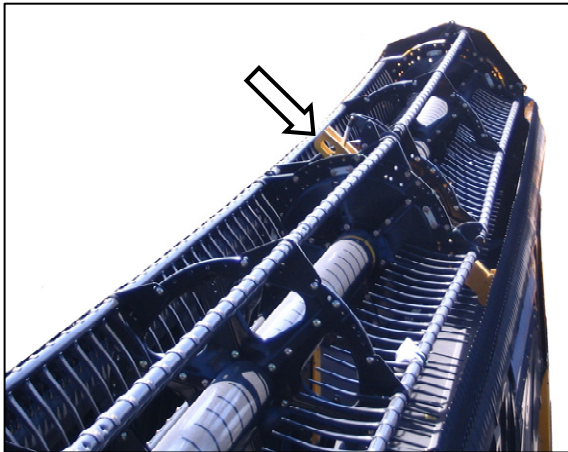

- Attach chain to shipping support at center reel arm.



CAUTION

Stand clear when lowering, as machine may swing.

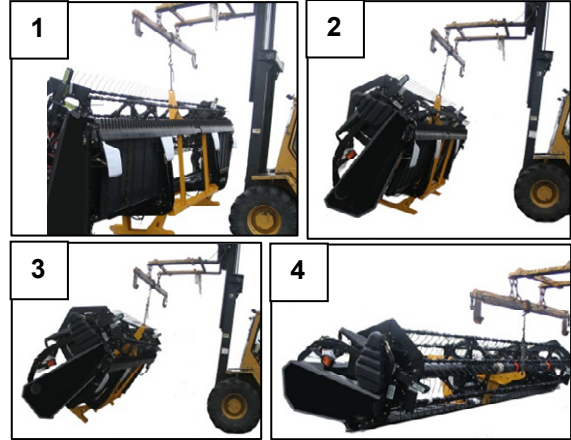

- Back up **SLOWLY** while lowering forks until header rests on the ground.

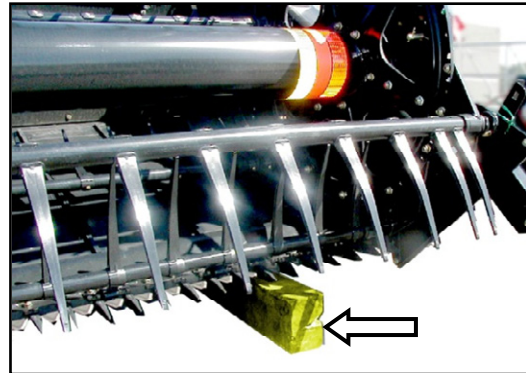

- Place 6 inch (150 mm) blocks under each end and center of cutterbar, and lower header onto blocks.
- Remove chain.

UNLOADING AND ASSEMBLY

STEP 3. REMOVE SHIPPING STANDS

The removable stands are painted yellow.

NOTE

Unless otherwise specified, discard stands, and all shipping material and hardware.

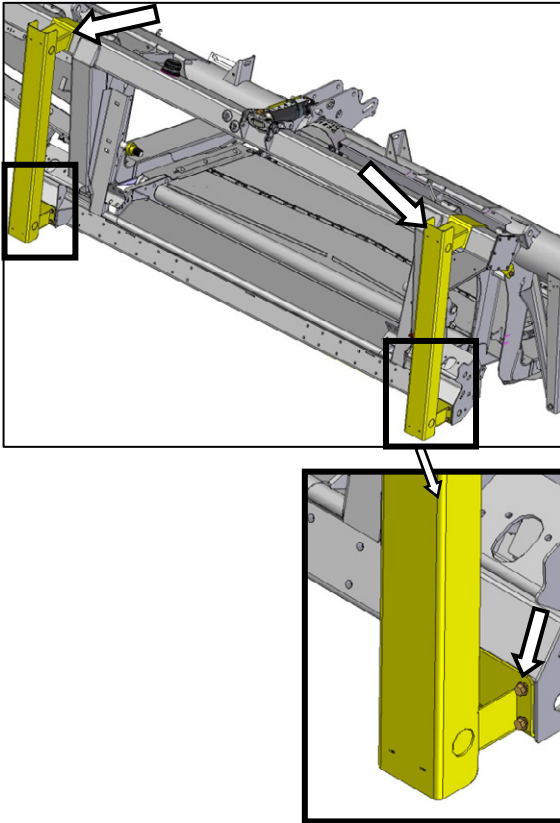

- a. Remove four bolts at the base of the two adapter frame stands, and lift shipping stands off adapter.

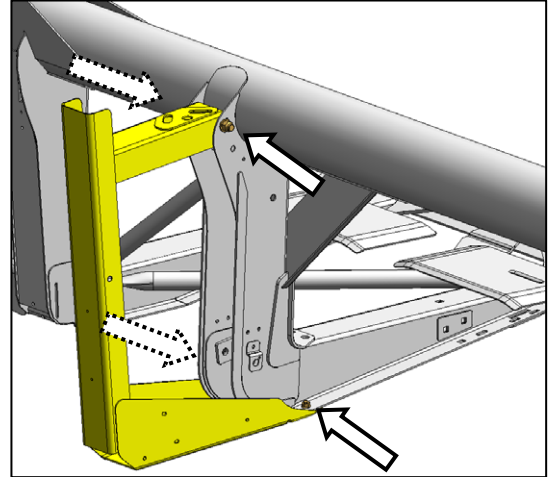

- b. Remove four bolts in each shipping stand on outboard header legs, and remove stands.

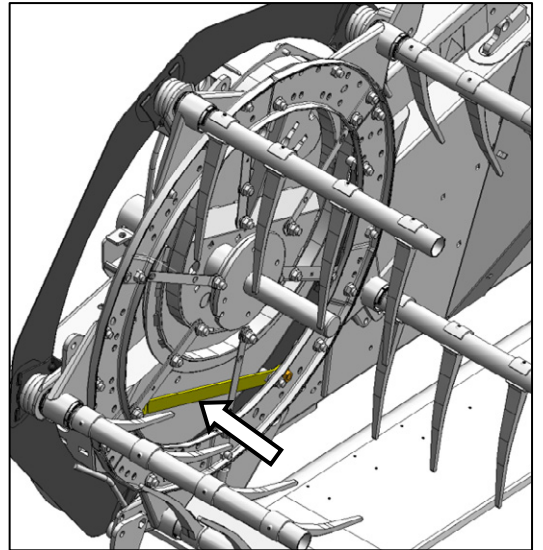

- c. Remove reel anti-rotation brace between reel and endsheet.

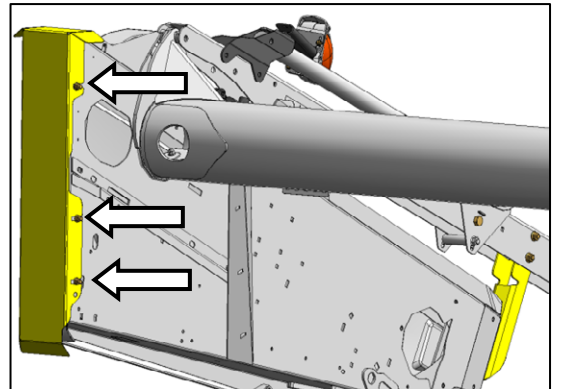

- d. Loosen three bolts in each end shield guard, and remove guard. Hardware can be removed when header end shields are opened.

UNLOADING AND ASSEMBLY

STEP 4. INSTALL REEL LIFT CYLINDERS

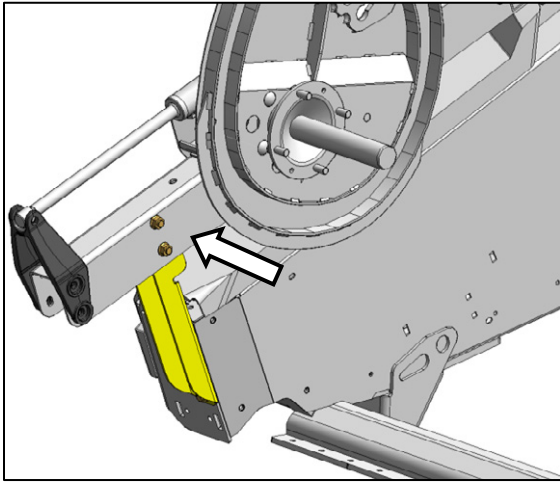

- a. Remove two top bolts on outboard reel arm support - both ends.

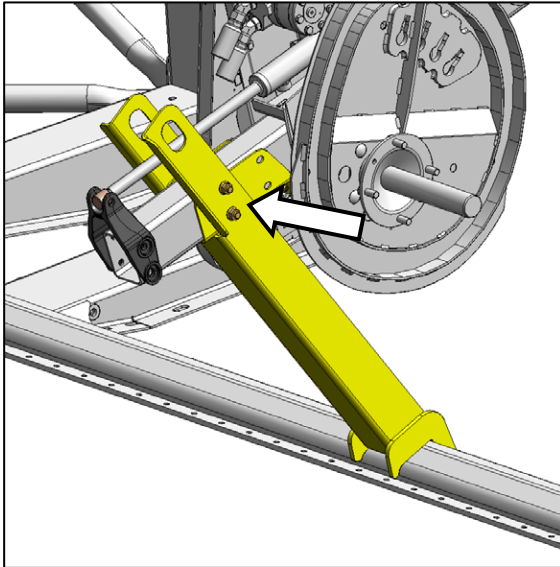

DUAL REEL ONLY

- b. Remove two top bolts on center reel arm support.

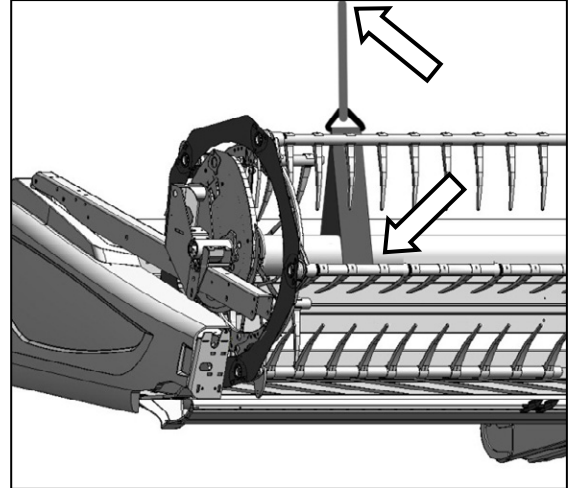

- c. Position sling around the reel tube close to outboard end of reel, and attach sling to a forklift (or equivalent).
- d. Remove shipping wire/banding from cylinder, and remove pins from lug and arm.
- e. Lift reel so that reel lift cylinder mounting holes line up with lug on endsheet and hole in reel arm.

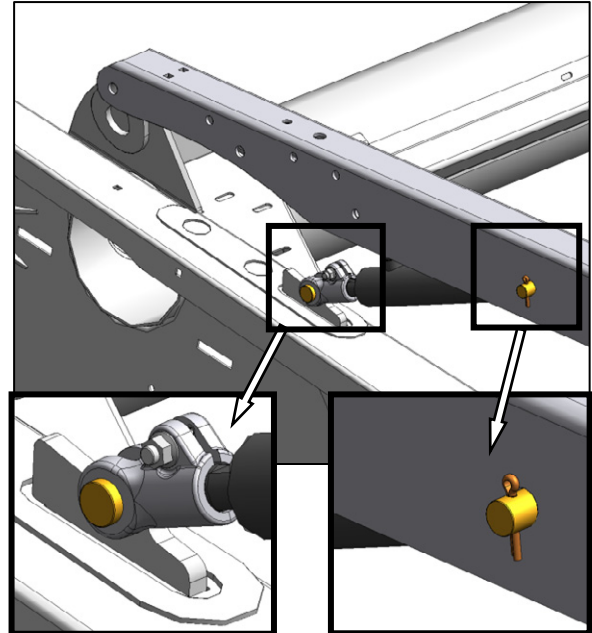

RH SHOWN - LH OPPOSITE

- f. Secure cylinder to endsheet and reel arm with pins as shown.

NOTE

Cotter pin **outboard** at reel arm;
Cotter pin **inboard** at endsheet.

(continued next page)

UNLOADING AND ASSEMBLY

NOTE

Steps g. to m. apply **only** to Dual Reel headers.

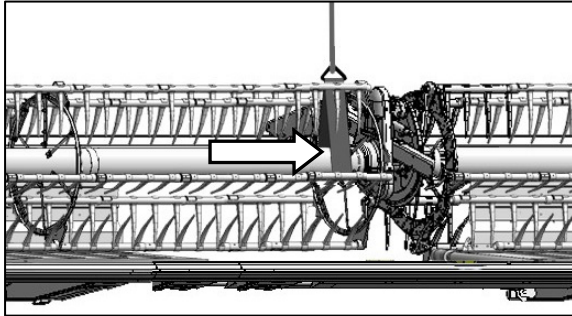

DUAL REEL

- g. Remove sling, and re-position around reel tube near reel center support arm.
- h. Lift reel to gain access to the center lift cylinder.
- i. Remove shipping wire/banding from center reel lift cylinder.

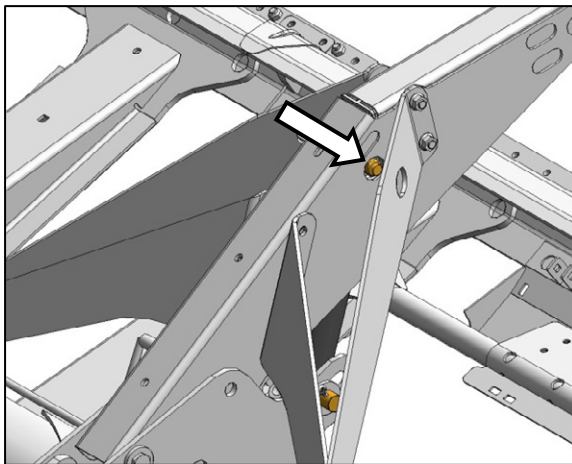

CENTER ARM - DUAL REEL ONLY

- j. Remove socket head bolt and nut from cylinder rod end.
- k. Attach rod end of cylinder to reel arm with socket head bolt and nut. Access hardware through holes in reel arm braces
- l. Remove pin at barrel end of cylinder.
- m. Adjust reel height so pin can be installed at barrel end of cylinder and mounting structure.

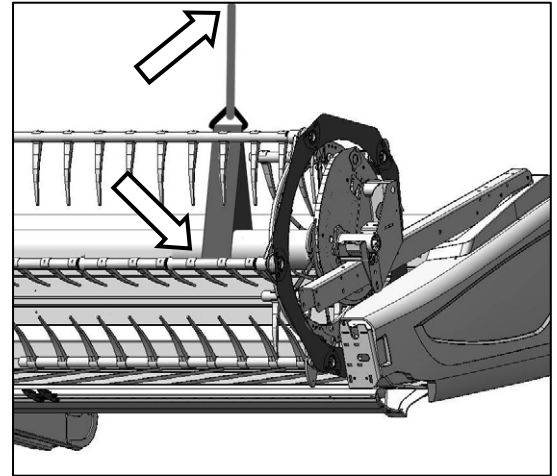

- o. Remove sling, and re-position around reel tube near opposite outboard reel arm.
- p. Remove shipping wire/banding from cylinder, and remove pins from lug and arm.

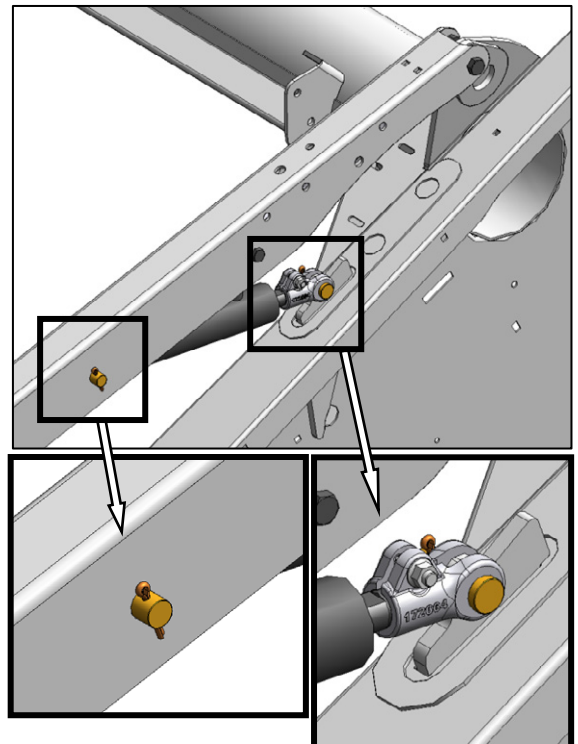

- q. Lift reel so that reel lift cylinder mounting holes line up with lug on endsheet and hole in reel arm.
- r. Secure cylinder to endsheet and reel arm with pins as shown.

NOTE

*Cotter pin outboard at reel arm;
Cotter pin inboard at endsheet.*

(continued next page)

UNLOADING AND ASSEMBLY

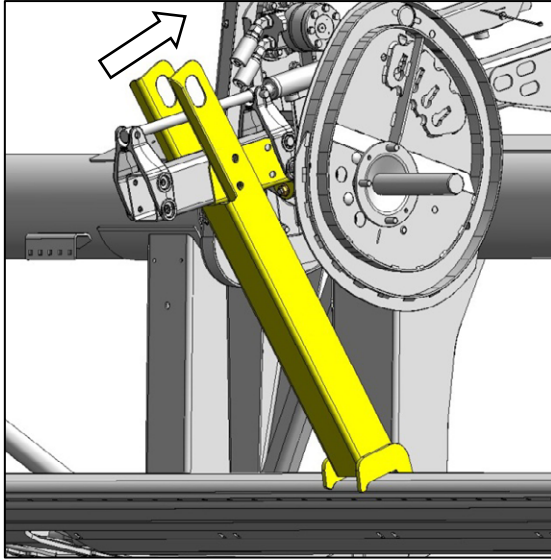

DUAL REEL ONLY

- s. Disengage center reel arm shipping support from cutterbar, and remove.

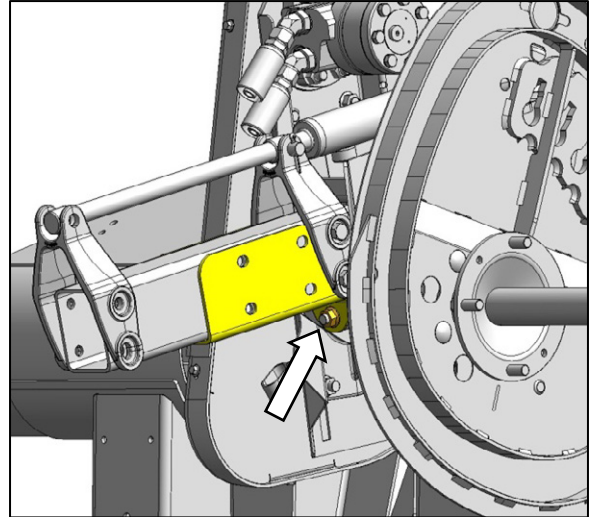

DUAL REEL ONLY

- w. Remove bolt locking reel fore-aft position at center reel arm, and remove center reel arm shipping channel.

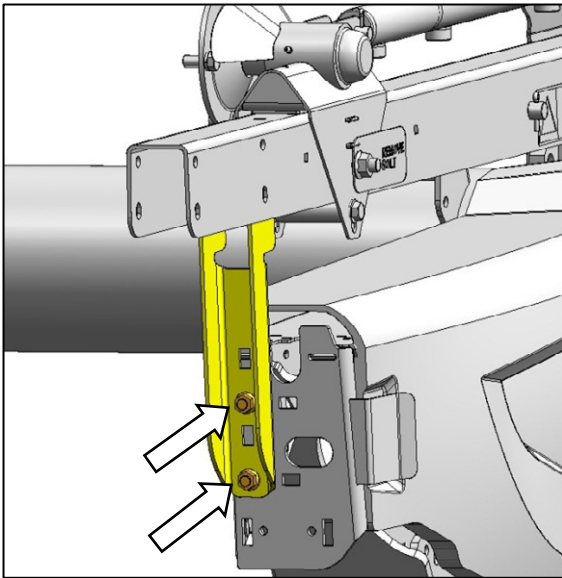

- t. Remove two bolts from reel arm supports at endsheet, and remove support. Repeat at other side.

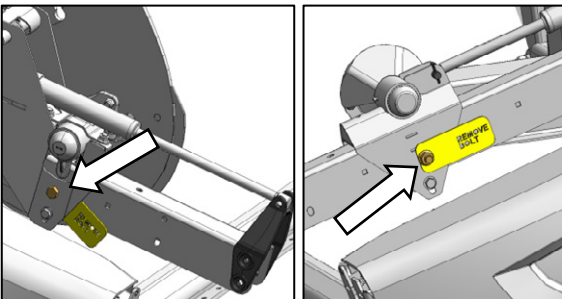

- u. Remove bolts and tags locking reel fore-aft position at outer reel arms.

UNLOADING AND ASSEMBLY

STEP 5. RE-POSITION GEARBOX

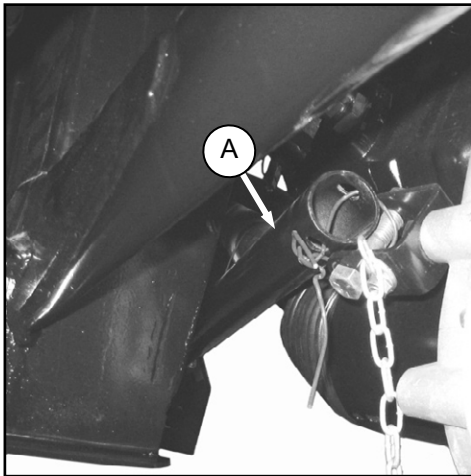

- a. Remove shipping wire and wrapping on brace, and swing brace (A) clear of gearbox.



- b. Loosen nut (B), and move bolt out of shipping position slot.

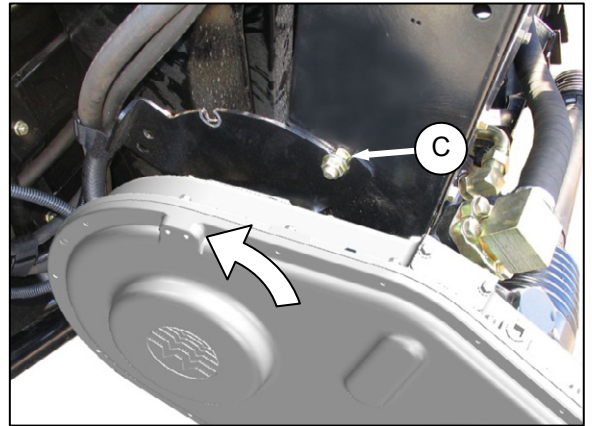

- c. Rotate gearbox, and move bolt into working position slot (C). Tighten nut.
d. Remove bolt and nut from bracket on gearbox.

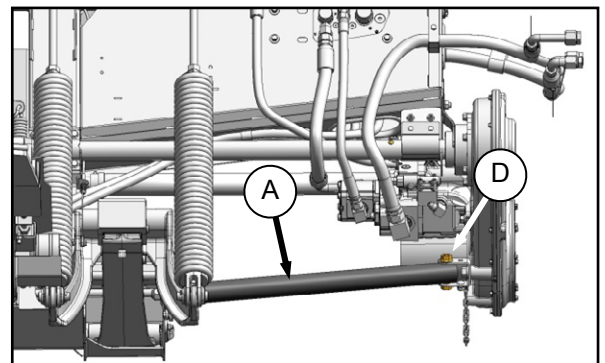

- e. Position brace (A) inside bracket, and re-install bolt (D) and nut.

UNLOADING AND ASSEMBLY

STEP 6A. INSTALL REEL SPEED SENSOR: HI-TORQUE SINGLE & DUAL REEL

NOTE

This step is **not** applicable to CASE-IH or New Holland combines. Proceed to **STEP 7. INSTALL OPTIONS.**

NOTE

If installing reel speed sensor on a single reel standard torque drive, proceed to **STEP 6B.**



CAUTION

To avoid personal injury, before servicing header or opening drive covers:

- Fully lower the header. If necessary to service in the raised position, always engage lift cylinder stops.
- Stop engine, and remove key.
- Engage park brake.

A. REMOVE COVER

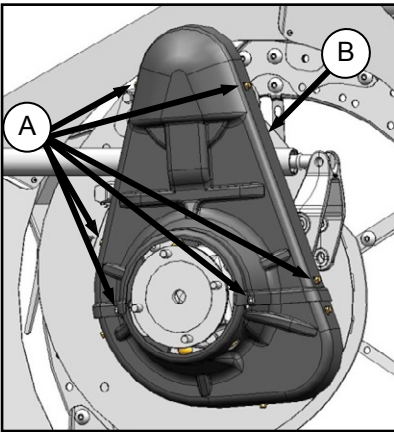

- a. **Dual Reel:** Remove six screws (A), and then remove drive upper cover (B).

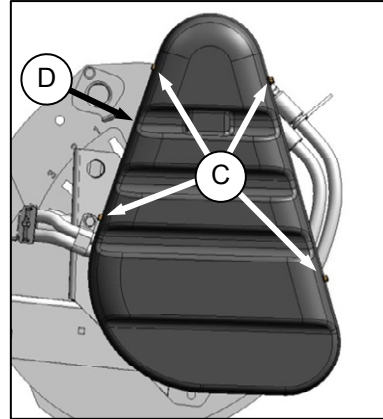

- b. **Single Reel:** Remove four screws (C), and remove drive cover (D).
- c. Clean grease from work area.

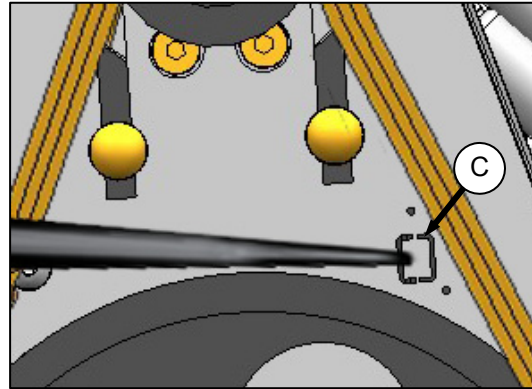

- d. Remove knock-out (C) in chain case for wire harness routing.

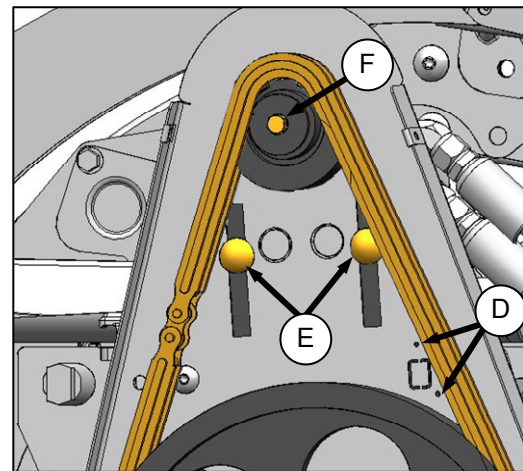

- e. If necessary, clean up holes (D) with a 0.125 in. (3.2 mm) drill.
- f. Remove bolts (E) in chain case.
- g. Remove bolt, lock washer and flatwasher from drive motor shaft at (F).

(continued next page)

UNLOADING AND ASSEMBLY

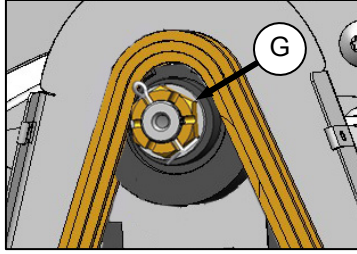

NOTE

If high torque drive is installed, remove cotter pin, castle nut (G) and flat washer.

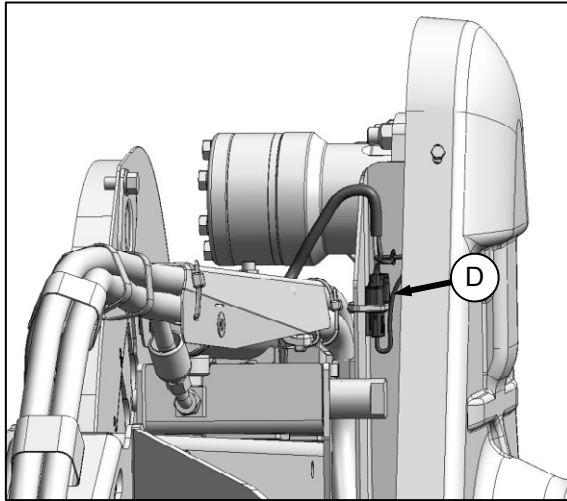

DR SHOWN - SR SIMILAR

- h. Retrieve existing harness (H) from reel arm.
- i. Proceed to procedure **B**, **C**, or **D** depending on your particular combine.

UNLOADING AND ASSEMBLY

B. JOHN DEERE SENSOR INSTALLATION

- Remove cover. See A. REMOVE COVER.
- Retrieve speed sensor kit from combine completion package.

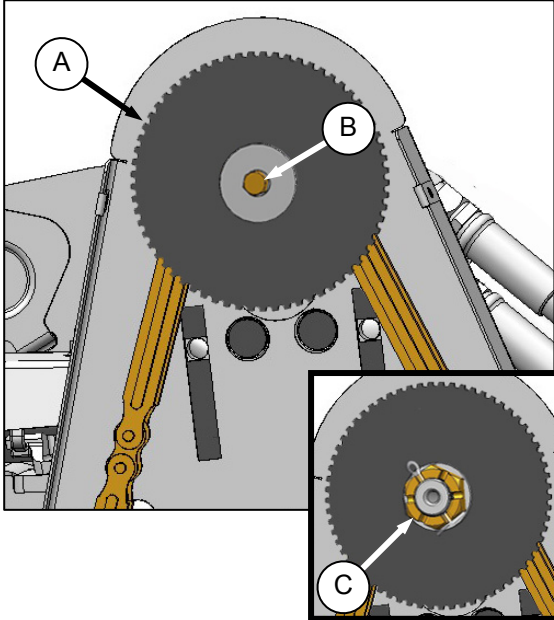

- Position speed sensor disc (A) on shaft, and re-install bolt, lock washer and flatwasher at (B). Torque to 18 ft·lbf (24 N·m).

NOTE

If high torque sprocket is installed, install flat washer, castle nut, and cotter pin (C).

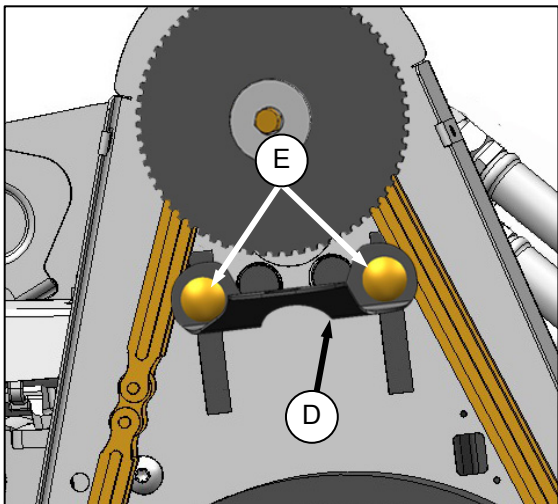

- Locate bracket (D) on chain case, and re-install bolts (E). Torque to 75 ft·lbf (102 N·m).

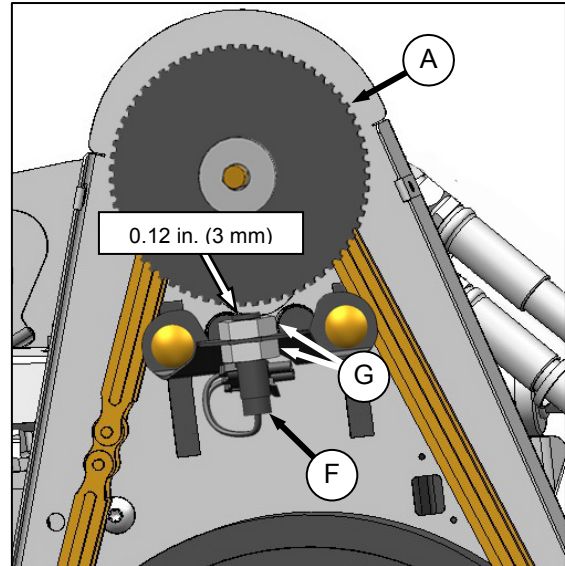

- Remove top nut on sensor (F), and locate sensor in bracket (D). Re-install nut.
- Adjust gap between sensor (F) and disc (A) to 0.12 in. (3 mm) with nuts (G). Tighten nuts.

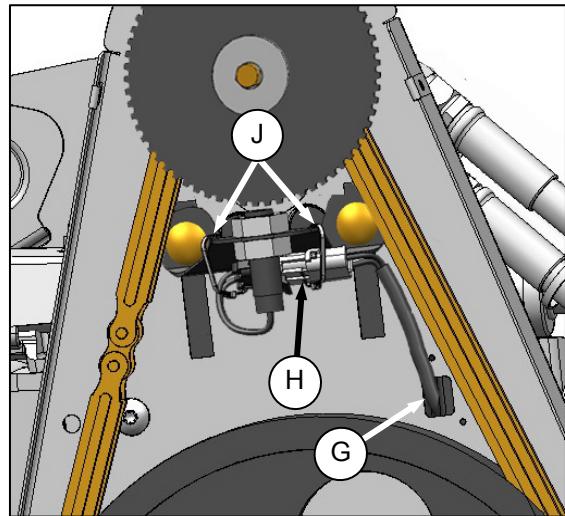

- Feed male connector on harness (G) through hole in chain case.
- Connect female end to sensor connector (H).
- Secure harness to support (D) with two cable ties (J).

(continued next page)

UNLOADING AND ASSEMBLY

IMPORTANT

Ensure harness is clear of chain and sprockets, and that motor can be moved up and down fully in slots without damaging harness.

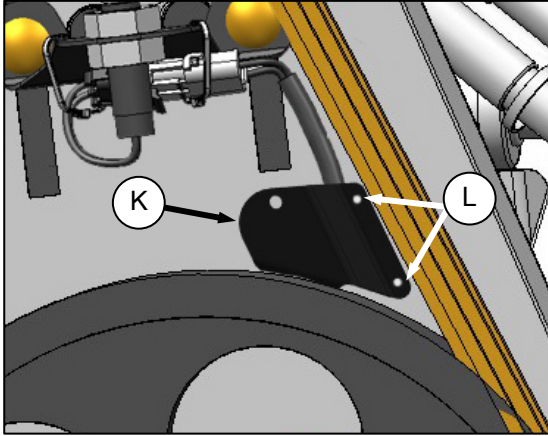

- j. Locate cover (K) over harness, align holes, and attach to chain case with two rivets (L).
- k. Proceed to **E. INSTALL COVER.**

UNLOADING AND ASSEMBLY

C. CAT LEXION 500 AND 700 SERIES SENSOR INSTALLATION

- Retrieve speed sensor kit from combine completion package. The contents are bagged and wired to the header.
- Remove cover. See A. REMOVE COVER.

IMPORTANT

The following steps c. and d. are required to establish the amount of slack in the harness, and to determine the harness location on the cover, so that when the drive chain is loosened, the harness or sensor will not be damaged.

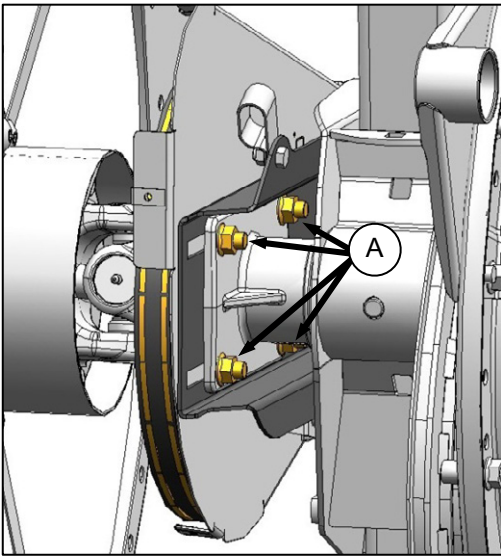

- Loosen four bolts (A) on chain case.

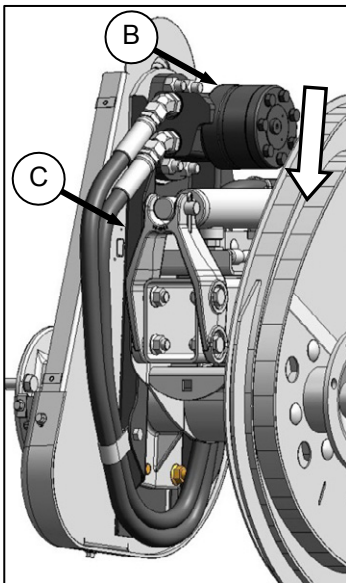

- Slide motor (B) and motor mount (C) down towards reel shaft until drive chain is loose.

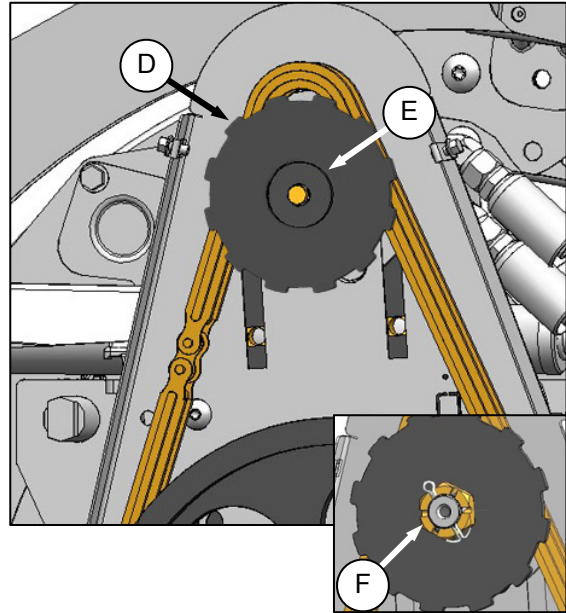

- Position speed sensor disc (D) on shaft, and re-install bolt, lock washer and flatwasher at (E). Torque to 18 ft·lbf (24 N·m).

NOTE

If high torque sprocket is installed, install flat washer, castle nut, and cotter pin (F).

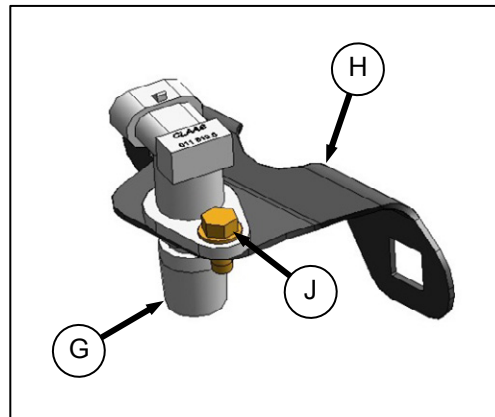

- Assemble sensor (G) in support (H), and secure sensor with 1/4 in. x 0.5 self-tapping screw (J).

(continued next page)

UNLOADING AND ASSEMBLY

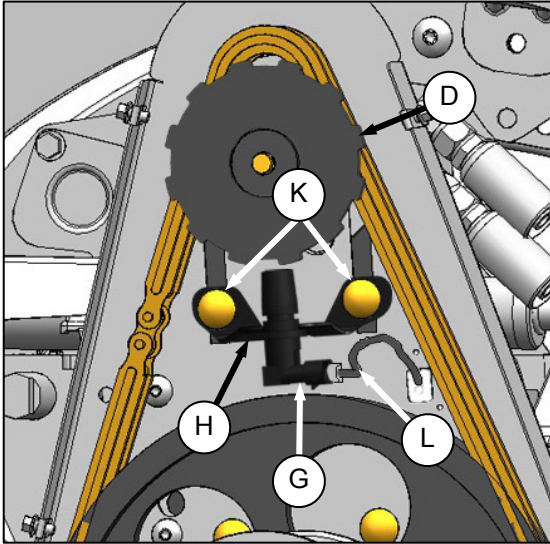

- g. Locate support (H) on chain case, and re-install bolts (K) removed in **STEP A**. If required, bend support so that sensor just clears the disc (D).
- h. Install nuts on bolts (K), but do not tighten.
- i. Adjust gap between sensor (G) and disc (D) to 0.12 inch (3 mm) by bending support.
- j. Retrieve wiring harness (L) from kit, and feed connector through hole in chain case. Route to existing harness on reel arm.
- k. Connect other end to sensor (G).

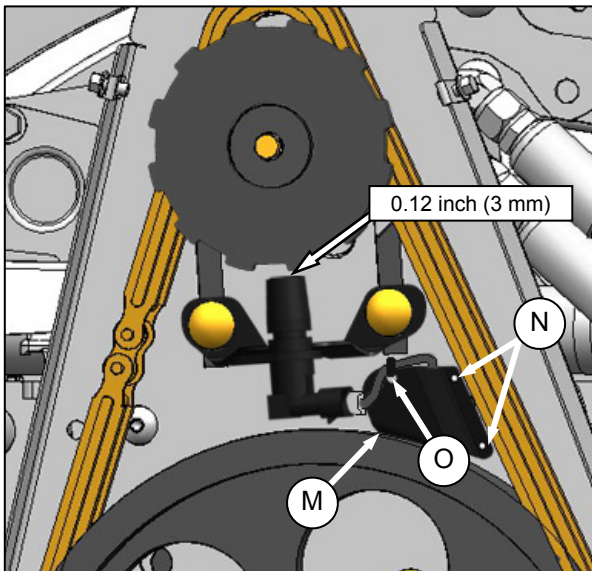

- l. Locate shield (M) over harness, align holes, and attach to chain case with two rivets (N).
- m. Secure harness (L) to shield (M) with cable tie (O) exactly as shown.

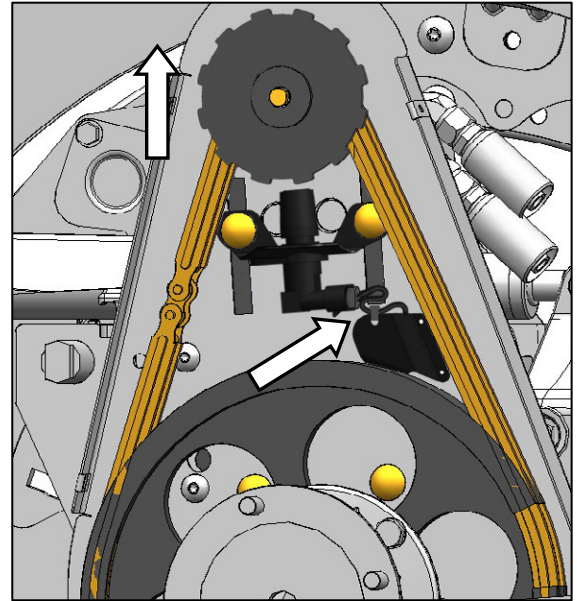

IMPORTANT

Ensure harness is clear of chain and sprockets, and that motor can be moved up and down fully in slots without damaging harness.

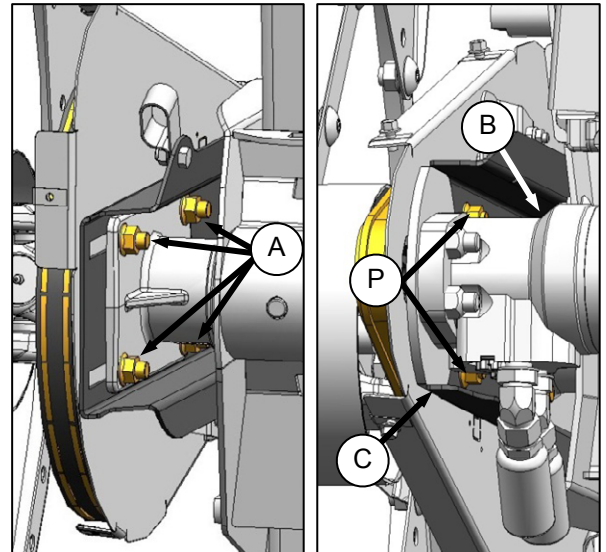

- n. Slide motor (B) and motor mount (C) up away from reel shaft. Check that there is sufficient slack in sensor harness so that sensor or harness are not damaged.
- o. Tighten chain so that hand force deflects the chain approximately 1/8 inch (3 mm). Tighten nuts (A) and (P) to 75 ft·lbf (102 N·m).
- p. Proceed to **E. INSTALL COVER**.

UNLOADING AND ASSEMBLY

D. AGCO SENSOR INSTALLATION

- Remove cover. See **A. REMOVE COVER.**
- Retrieve speed sensor kit from combine completion package. The contents are bagged and wired to the header.

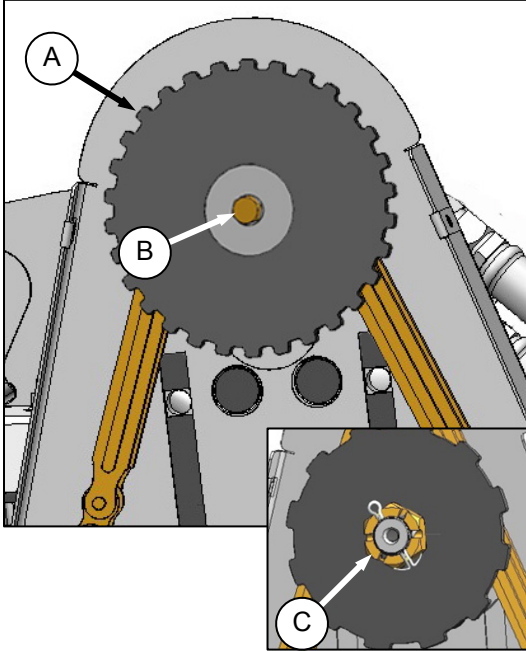

- Position speed sensor disc (A) on shaft, and re-install bolt, lock washer and flat washer at (B). Torque to 18 ft·lbf (24 N·m).

NOTE

If high torque sprocket is installed, install flat washer, castle nut, and cotter pin (C).

NOTE



2-WIRE SENSOR



3-WIRE SENSOR

Install 2-wire sensor for Gleaner R and S Series combines. Install 3-wire sensor for all other AGCO models.

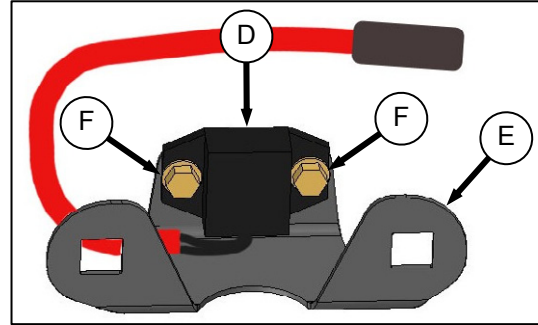

- Assemble sensor (D) to support (E) with self-tapping screws (F).

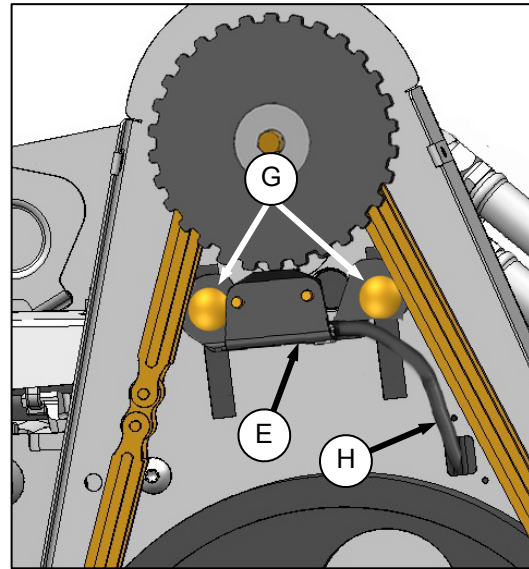

- Locate support (E) on chain case, and re-install bolts (G). Torque to 75 ft·lbf (102 N·m).
- Route connector end of sensor harness (H) through hole in drive case as shown.

(continued next page)

UNLOADING AND ASSEMBLY

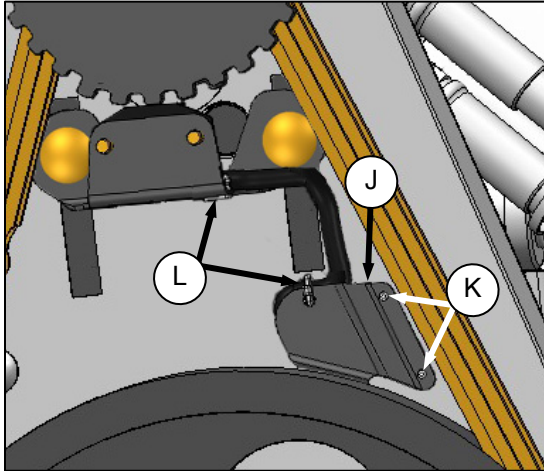

- g. Locate cover (J) over harness, align holes and attach to chain case with two rivets (K).
- h. Secure harness to cover (J) and support with cable ties (L) exactly as shown.

IMPORTANT

Ensure harness is clear of chain and sprockets, and that motor can be moved up and down fully in slots without damaging harness.

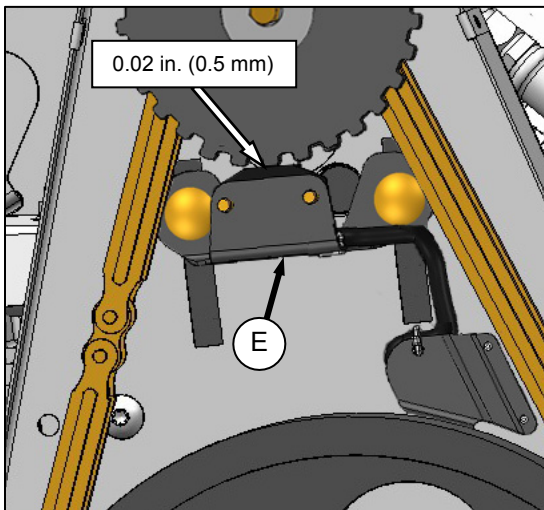

- i. Adjust gap between sensor and disc to 0.02 inch (0.5 mm) by bending support (E).
- j. Proceed to **E. INSTALL COVER**.

E. INSTALL COVER

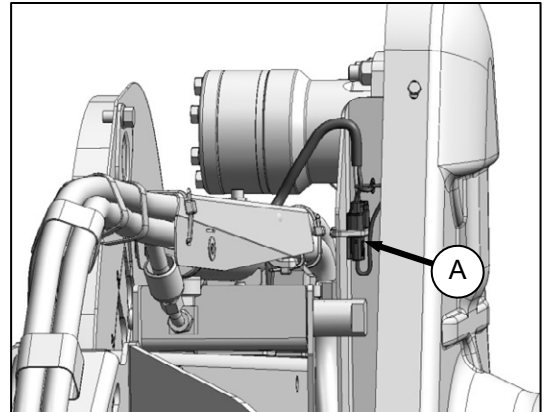

DR SHOWN - SR SIMILAR

- a. Attach sensor connector to existing harness (A) behind chain case.
- b. Re-install drive cover:

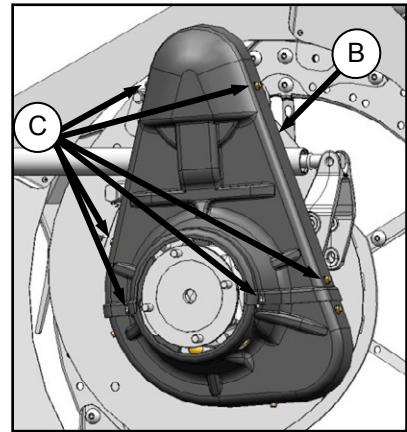

- 1. **Dual Reel:** Position upper cover (B) onto drive and secure with six screws (C).

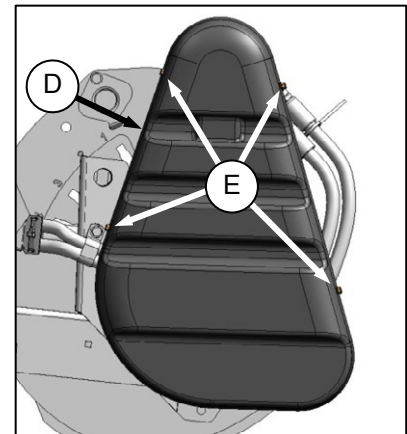

- 2. **Single Reel:** Position cover (D) onto drive and secure with four screws (E).

UNLOADING AND ASSEMBLY

STEP 6B. INSTALL REEL SPEED SENSOR: SINGLE REEL, STD TORQUE

NOTE

This step is **not** applicable to CASE-IH or New Holland combines. Proceed to **STEP 7. INSTALL OPTIONS.**



CAUTION

To avoid personal injury, before servicing header or opening drive covers:

- Fully lower the header. If necessary to service in the raised position, always engage lift cylinder stops.
- Stop engine, and remove key.
- Engage park brake.

A. REMOVE COVER

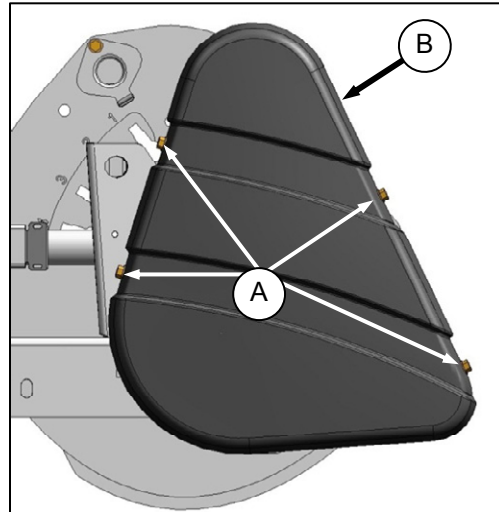

- a. Remove four screws (A), and remove drive cover (B).
- b. Clean grease from work area.

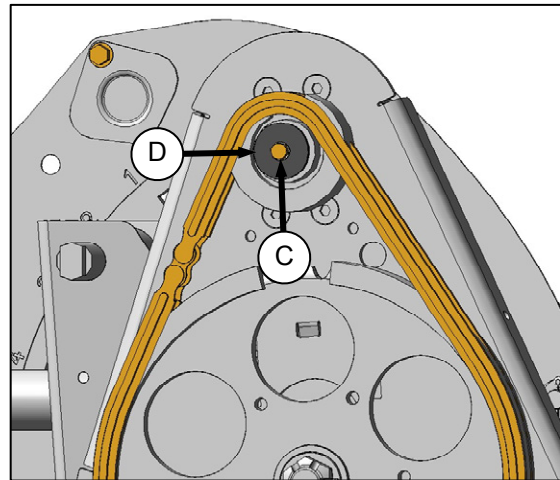

- c. Remove bolt (C), lock washer and flat washer (D) from drive motor shaft.
- d. Proceed to procedure **B, C, or D** depending on your particular combine.

UNLOADING AND ASSEMBLY

B. JOHN DEERE SENSOR INSTALLATION

- a. Remove cover. See **A. REMOVE COVER.**
- b. Retrieve speed sensor kit from combine completion package.

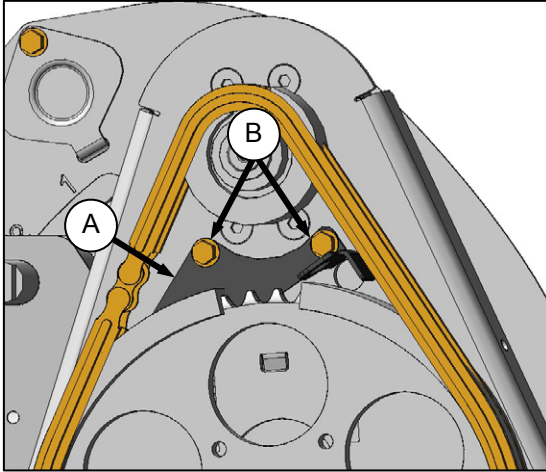

- c. Locate sensor holder (A) on reel drive case, and secure with two 3/8 in. x 0.62 long self-tapping screws (B) in existing holes in drive case.

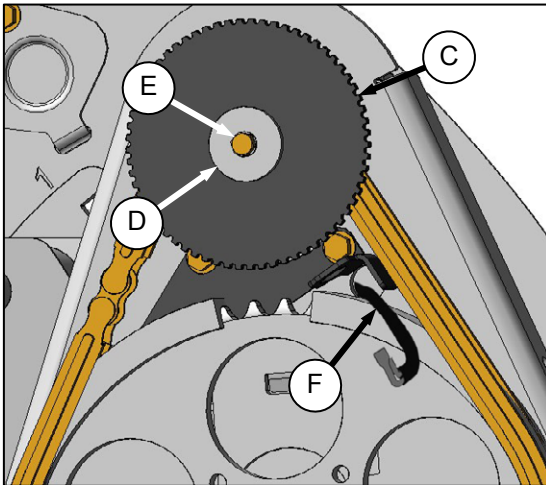

- d. Position speed sensor disc (C) on shaft, and re-install flat washer (D), lock washer, and bolt (E). Torque to 18 ft·lbf (24 N·m).
- e. Route sensor harness (F) through hole in drive case as shown.

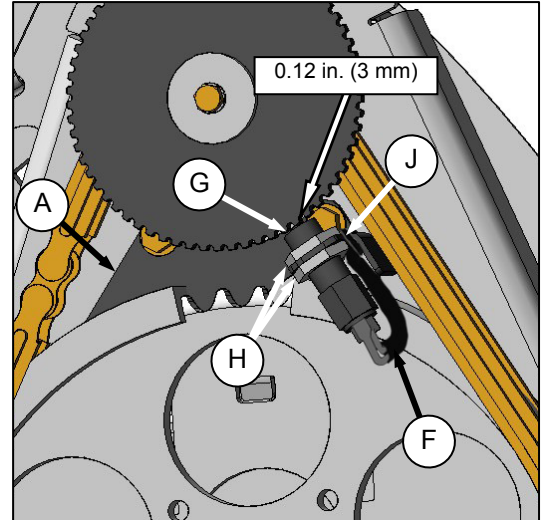

- f. Remove top nut on sensor (G), and locate sensor in holder (A). Re-install nut.
- g. Adjust gap between sensor (G) and disc (C) to 0.12 in. (3 mm) with nuts (H). Tighten nuts.
- h. Connect female end of harness (F) to sensor (G).
- i. Secure harness to support (A) with plastic cable tie (J).
- j. Proceed to **E. INSTALL COVER.**

UNLOADING AND ASSEMBLY

C. CAT LEXION 500 AND 700 SERIES SENSOR INSTALLATION

- a. Retrieve speed sensor kit from combine completion package. The contents are bagged and wired to the header.
- b. Remove cover. See **A. REMOVE COVER.**

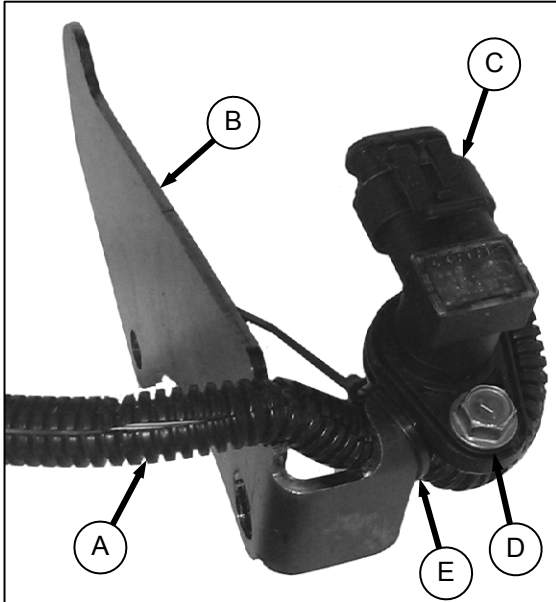

- c. Route sensor harness (A) through holder (B) as shown.
- d. Assemble sensor (C) to holder (B) with self-tapping screw (D).
- e. Secure harness to holder (B) with plastic cable tie (E).

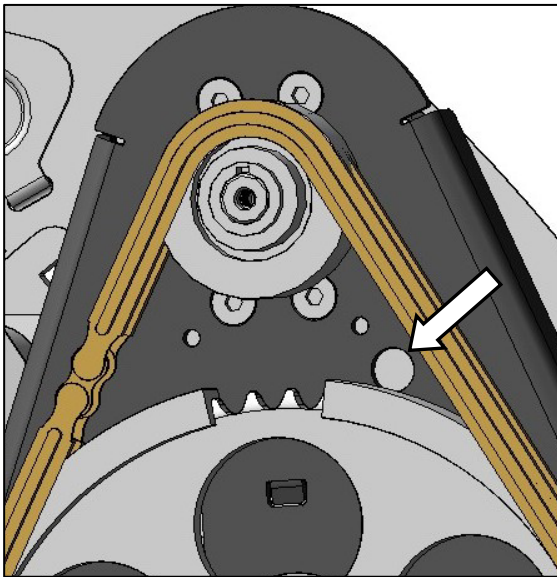

- f. Route sensor harness (A) through hole in reel drive case as shown.

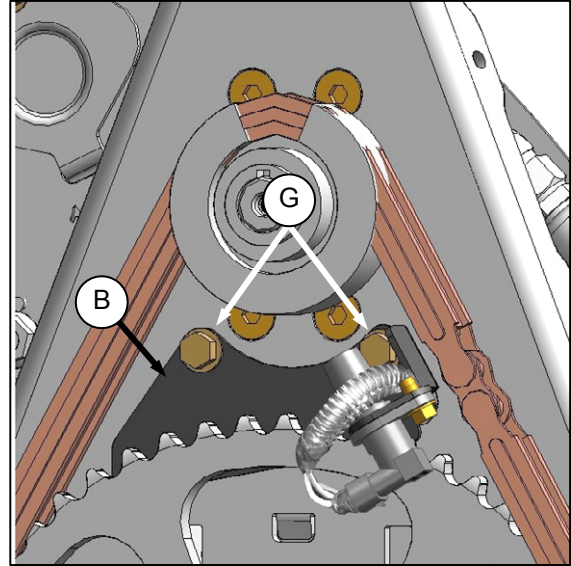

- g. Locate sensor holder (B) on reel drive case, and secure with two 3/8 in. x 0.62 long self-tapping screws (G). Do not fully tighten.

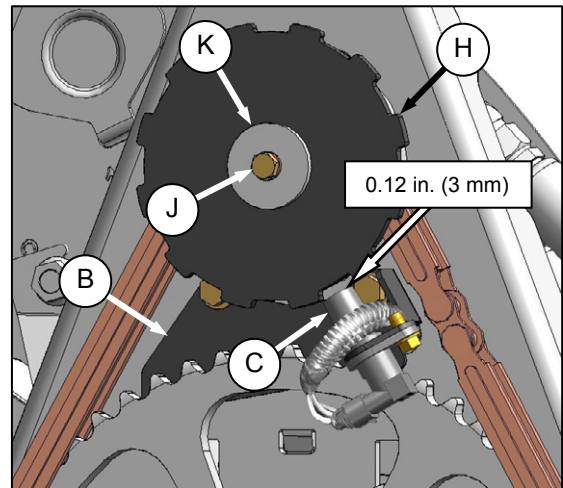

- h. Install sensor disc (H) onto drive sprocket with bolt (J), lock washer, and flat washer (K).
- i. Torque bolt to 18 ft·lbf (24 N·m).
- j. Adjust gap between sensor (C) and disc (H) to 0.12 in. (3 mm) by moving sensor holder (B). Tighten screws (G) after gap is set. Proceed to **E. INSTALL COVER.**

UNLOADING AND ASSEMBLY

D. AGCO SENSOR INSTALLATION

- Remove cover. See **A. REMOVE COVER.**
- Retrieve speed sensor kit from combine completion package. The contents are bagged and wired to the header.

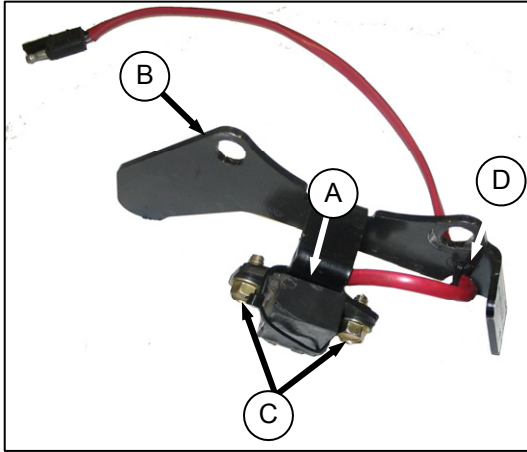

- Assemble sensor (A) to holder (B) with self-tapping screws (C).



2-WIRE SENSOR



3-WIRE SENSOR

NOTE

Install 2-wire sensor for Gleaner R and S Series combines. Install 3-wire sensor for all other AGCO models.

- Secure wire to holder with plastic cable tie (D).

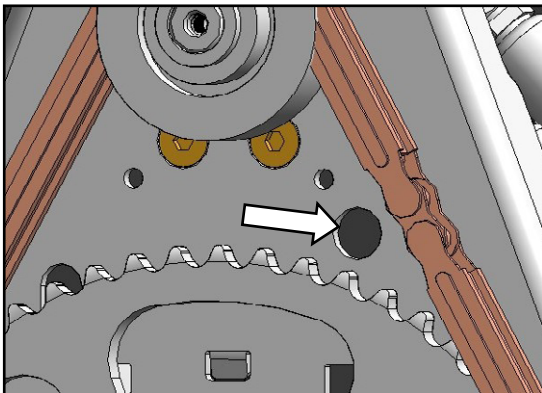

- Route connector end of sensor wire through hole in drive case (as shown).

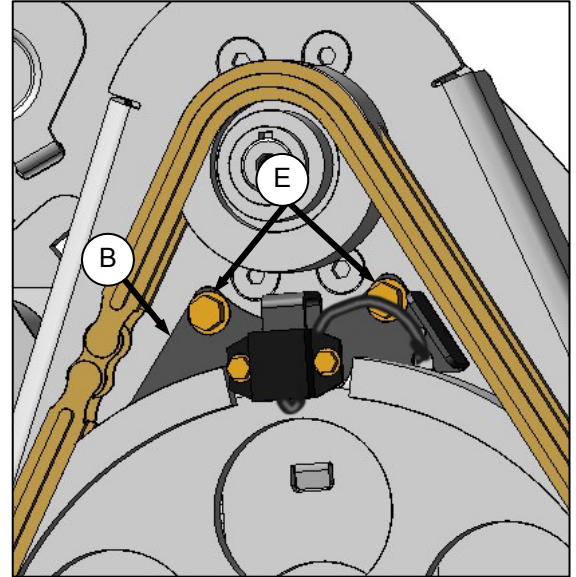

- Locate sensor holder (B) on reel drive case, and secure with two 3/8 in. x 0.62 long self-tapping screws (E). Do not fully tighten.

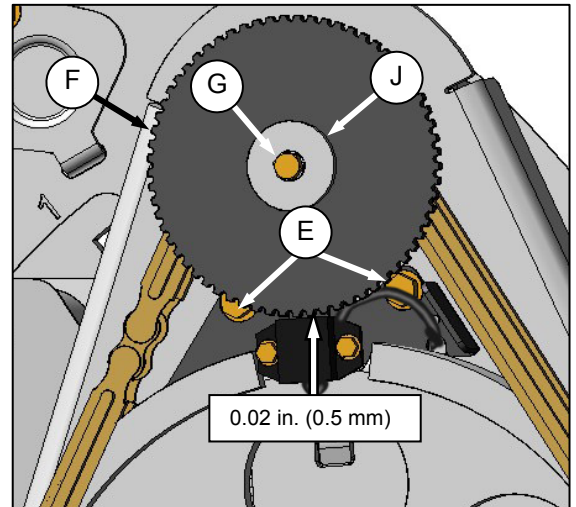

- Install sensor disc (F) onto drive sprocket with bolt (G), lockwasher, and flat washer (J). Torque bolt to 18 ft-lbf (24 N-m).
- Adjust gap between sensor and disc to 0.02 in. (0.5 mm) by moving sensor holder (B). Tighten screws (E) after gap is set.

IMPORTANT

Ensure harness is clear of chain and sprockets, and that motor can be moved up and down fully in slots without damaging harness.

- Proceed to **E. INSTALL COVER.**

UNLOADING AND ASSEMBLY

E. INSTALL COVER

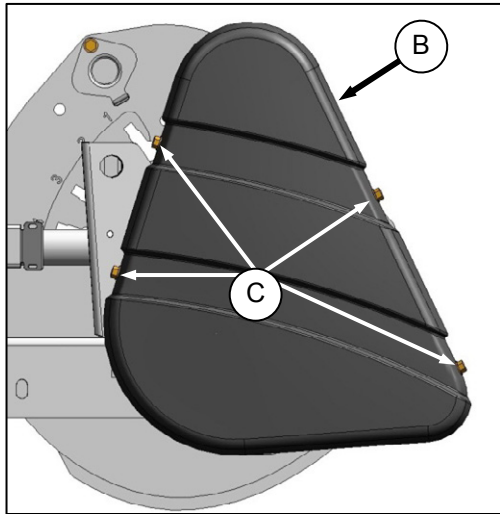

- a. Position cover (B) onto drive, and secure with four screws (C).

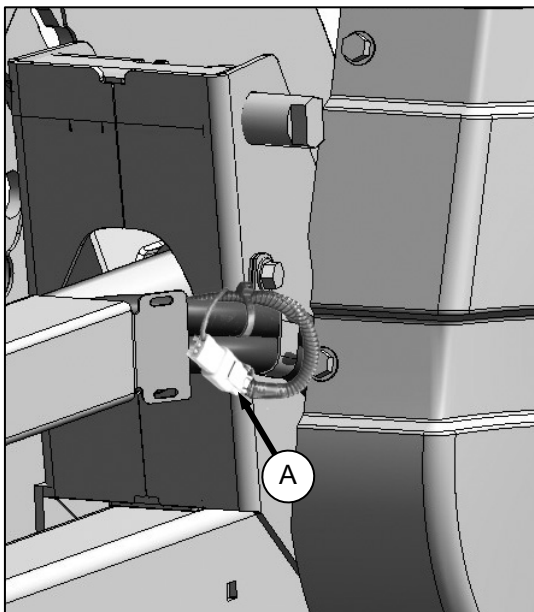

- b. Attach sensor connector to existing harness (A) behind chain case.

STEP 7. INSTALL OPTIONS

Retrieve kits supplied as options with the header, and install in accordance with installation instructions supplied in each kit.

UNLOADING AND ASSEMBLY

STEP 8. SET-UP ADAPTER

A. FILLER CAP

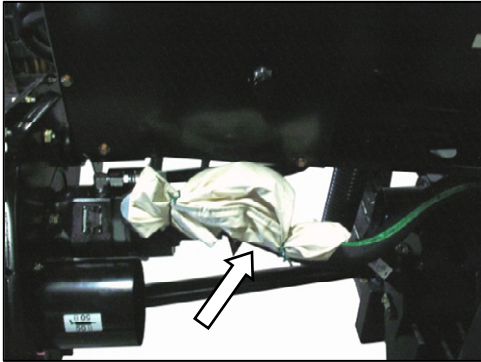

- a. Remove bag from driveline and retrieve filler cap from bag.



- b. Remove yellow shipping cover (A) from adapter frame. Discard cover. Keep screws.



CAUTION

Cap may be under pressure. Allow pressure to equalize by lifting cap slightly with some of the screws remaining.

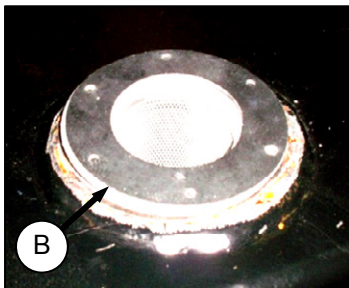

- c. There are two gaskets - one on either side of the filler strainer flange. Remove the top gasket (B) for use in step d.

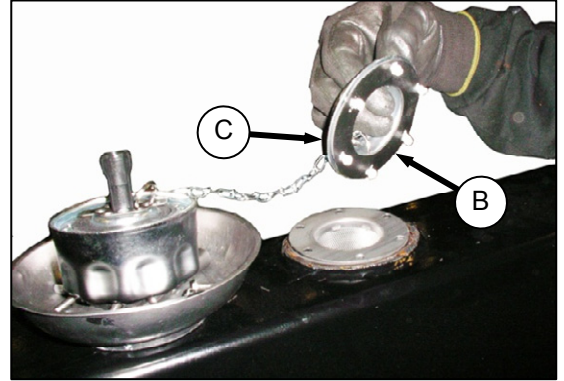

- c. Place gasket (B) that was removed from the top of the filler strainer onto filler cap neck (C), and align holes.
- d. Install #10-32 screws on filler cap neck (C), pressing screws through the gasket (B).
- e. Apply Loctite® #565 (or equivalent) to screws.

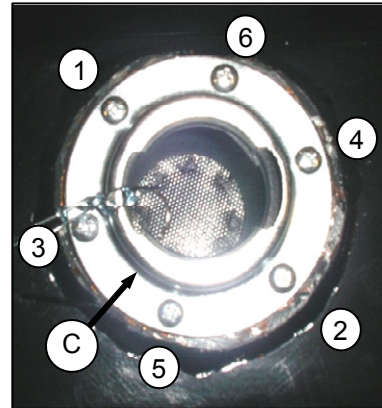

- f. Place filler cap neck (C) (complete with screws) over opening, aligning the machine screws with the threaded holes.
- g. Carefully thread in the machine screws using a cross pattern (see photo above) to prevent cross threading of tapped holes.
- h. Repeat pattern to gradually tighten screws to 31 lbf-in. (3.5 N·m).



- i. Install filler cap (D).

UNLOADING AND ASSEMBLY

B. FLIGHTING EXTENSIONS

Flighting extension kits may have been supplied with your header to improve feeding in certain crops such as rice. They are not recommended in cereal crops.

APPLICABLE COMBINES: All except New Holland CR960, 9060, 970, 9070, and 9080.

If necessary, remove auger flighting extensions as follows.

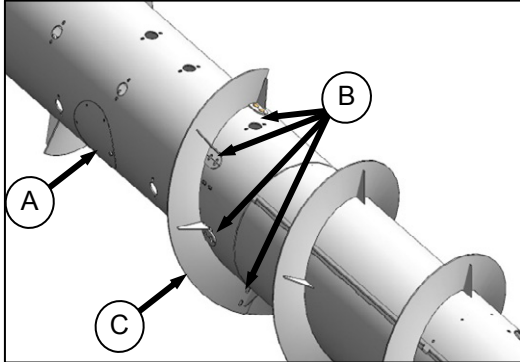

- Remove access cover (A).
- Remove eight bolts (B), washers, and nuts that secure flighting extension (C) to auger, and remove extension.
- Repeat for other flighting extension.
- Re-install access cover (A).

C. STRIPPER BARS

Stripper bar kits may have been supplied with your header to improve feeding in certain crops such as rice. They are not recommended in cereal crops.

APPLICABLE COMBINES: All except New Holland CR960, 9060, 970, 9070, and 9080.

If necessary, remove auger stripper bars as follows:

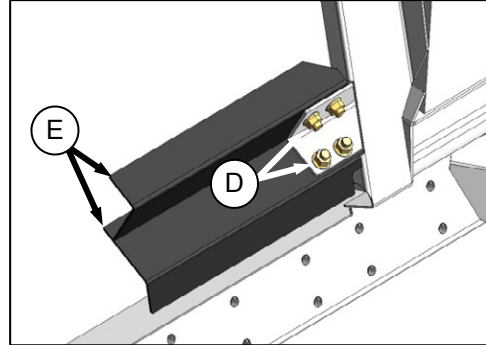

- Remove four bolts (D) and nuts securing bars (E) to adapter frame, and remove bars.
- Repeat for opposite set of stripper bars.

UNLOADING AND ASSEMBLY

D. CR FEEDER DEFLECTORS

For New Holland CR 960, 9070, and 9080 combines, feeder kits have been installed on adapter at the factory to improve feeding into the feeder house. They may also have been installed as an option on older machines. If necessary, they can be removed.

CA25 adapters for the CR Models listed have short feeder kits installed at the factory. Long feeder kits are provided for narrow feeder house combines, and are dealer-installed to replace short feeder kits.

COMBINE MODEL	FEEDER HOUSE SIZE	FEEDER KIT SIZE
CR970, 9070, 9080	Wide	Short: 200 mm
CR960, 9060, 940, 9040	Narrow	Long: 325 mm

If required, replace the feeder deflectors as follows:

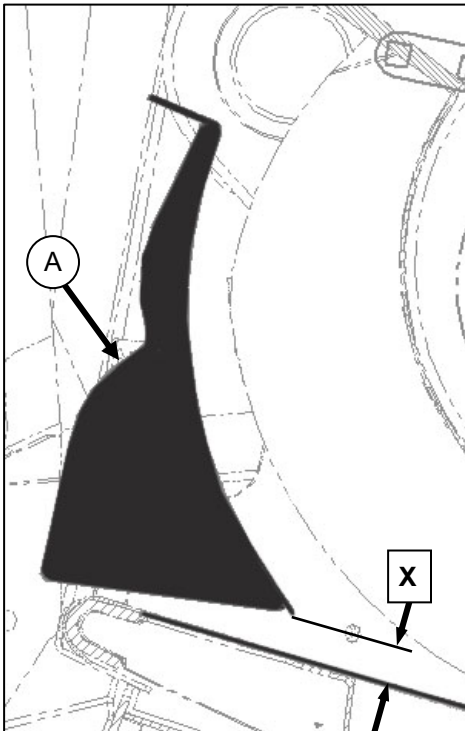

- a. Determine position of existing deflector (A) by measuring gap 'X' between deflector forward edge and pan.

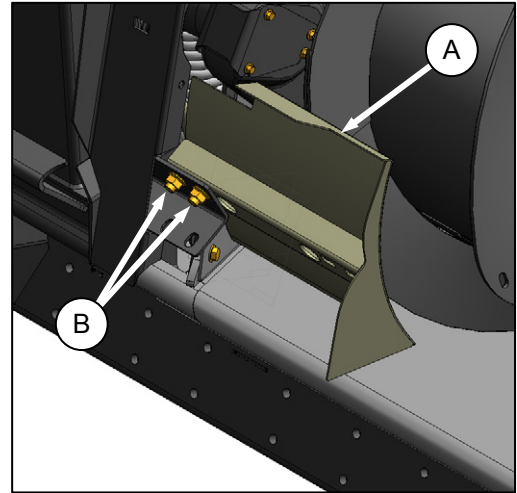

LH SHOWN - RH OPPOSITE

- b. Remove two bolts (B) and nuts securing deflector (A) to adapter frame, and remove deflector.
- c. Position replacement deflector, and secure with bolts (B) and nuts. Maintain dimension 'X' from existing deflector for replacement deflector.
- d. Repeat for opposite deflector.
- e. After attaching header to combine, extend center-link fully, and check gap between deflector and pan. Maintain 7/8 in. (22 mm) +/- 1/8 in. (3 mm).

UNLOADING AND ASSEMBLY

STEP 9. ATTACH TO COMBINE

Refer to specific section for your combine.

COMBINE	SECTION
CASE IH	A
JOHN DEERE 60, 70 SERIES	B
LEXION	C
NEW HOLLAND	D
AGCO	E

NOTE

Kits are available to allow attachment to Case 23 and 25 Series Combines, as well as John Deere 50 Series Combines. See your MacDon Dealer.

IMPORTANT

Ensure that applicable functions (AHHC, Draper Header Option, Hydraulic Center-link Option, Hydraulic Reel Drive, etc.) are enabled on the combine and combine computer. Failure to do so may result in improper header operation.

A. CASE IH 7010, 8010, 7120, 8120, 5088, 6088, 7088

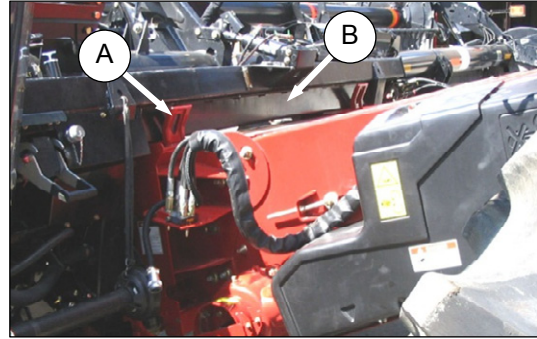

- Slowly drive combine up to adapter until feeder house saddle (A) is directly under the adapter top cross member (B).
- Raise feeder house slightly to lift adapter, ensuring feeder saddle is properly engaged in adapter frame.



CAUTION

Stop engine, and remove key from ignition before leaving Operator's seat for any reason. A child or even a pet could engage an idling machine.

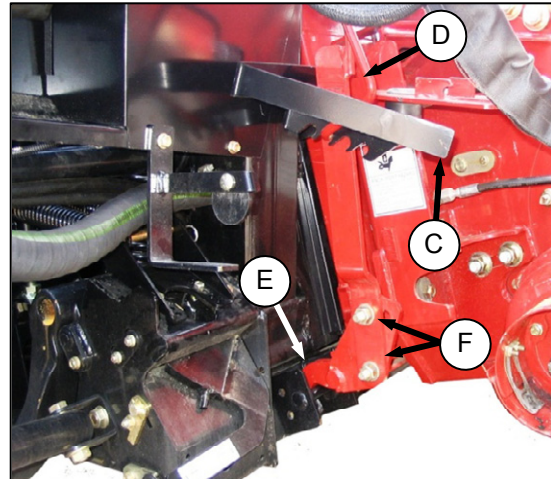

- Lift lever (C) on adapter at left side of feeder house, and push handle (D) on combine to engage locks (E) on both sides of the feeder house.
- Push down on lever (C) so that slot in lever engages handle to lock handle in place.
- If lock (E) does not fully engage pin on adapter when (C) and (D) are engaged, loosen bolts (F), and adjust lock as required. Re-tighten bolts.

(continued next page)

UNLOADING AND ASSEMBLY

- f. Connect combine hydraulic quick coupler to receptacle (G) on adapter as follows:

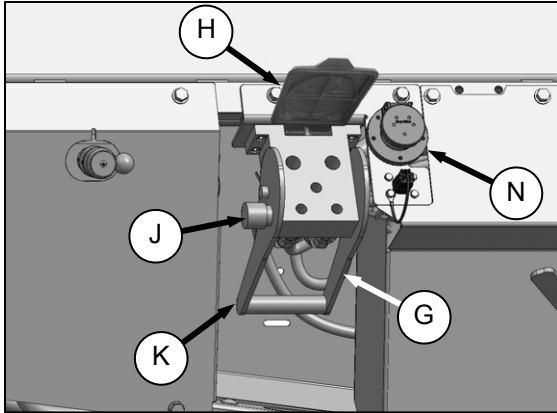

1. Open cover (H).
2. Push in lock button (J), and pull handle (K) to full open position.

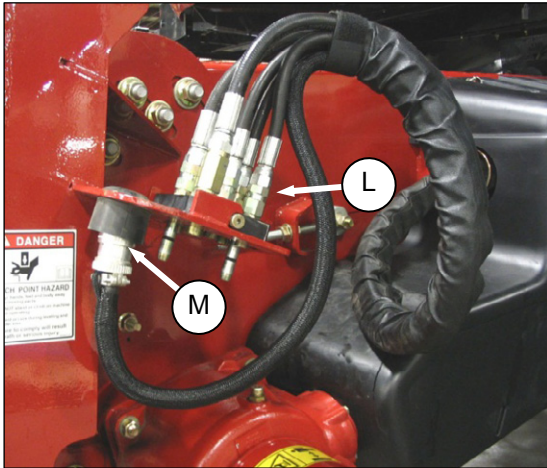

3. Remove coupler (L) from combine, and clean mating surfaces.

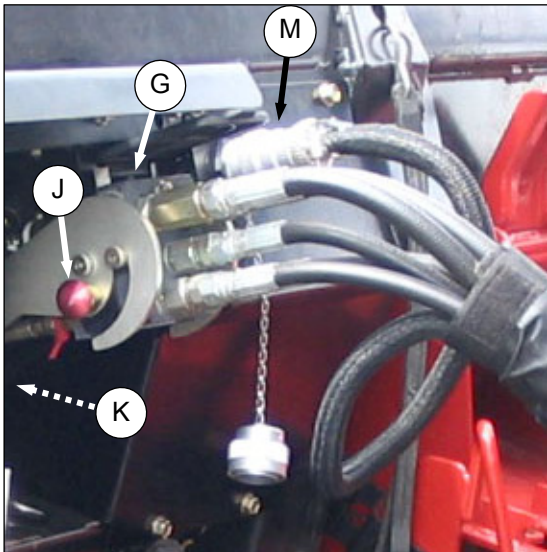

4. Position onto adapter receptacle (G), and push handle (K) to engage coupler pins into receptacle.

5. Push handle to closed position until lock button (J) snaps out.

- g. Remove cover on adapter electrical receptacle (N). See illustration in opposite column.

- h. Remove electrical connector (M) from storage cup on combine, and route to adapter receptacle.

- i. Align lugs on connector with slots in receptacle, push connector onto receptacle, and turn collar on connector to lock it in place.

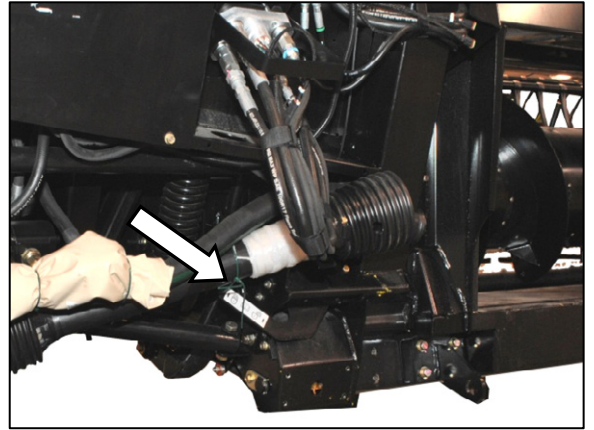

- j. Remove shipping wire from driveline and float lock lever.

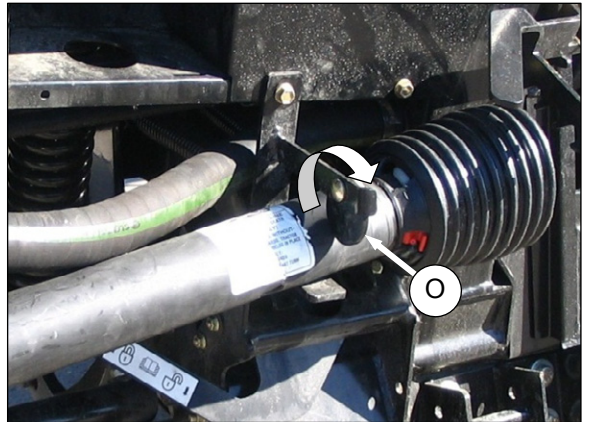

- k. Rotate disc (O) on adapter driveline storage hook, and remove driveline from hook.

(continued next page)

UNLOADING AND ASSEMBLY

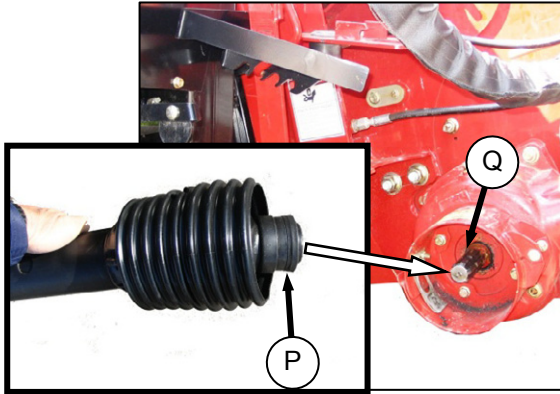

- I. Pull back collar (P) on end of driveline, and push onto combine output shaft (Q) until collar locks.

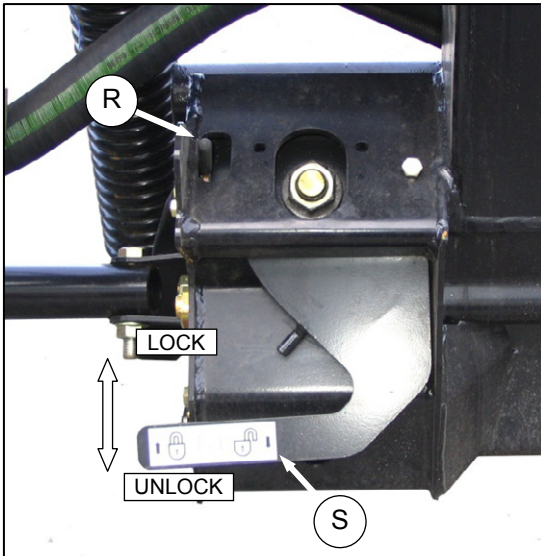

- m. Disengage both adapter float locks by moving latch (R) away from adapter, and moving lever (S) at each lock to lowest position.
- n. Proceed to **STEP 10. ATTACH CAM ARMS** (page 47).

UNLOADING AND ASSEMBLY

B. JOHN DEERE 60, 70 SERIES

Contour Master, Level Land

I. Install Reel Fore-Aft / Header Tilt Switch

This step is applicable to all John Deere S-series combines only. The switch allows the combine Operator to select either reel fore-aft mode or header tilt mode (if hydraulic center-link is installed).

- a. Prepare the combine cab for installing the switch and harness as follows:
 1. Open storage compartment on the console.

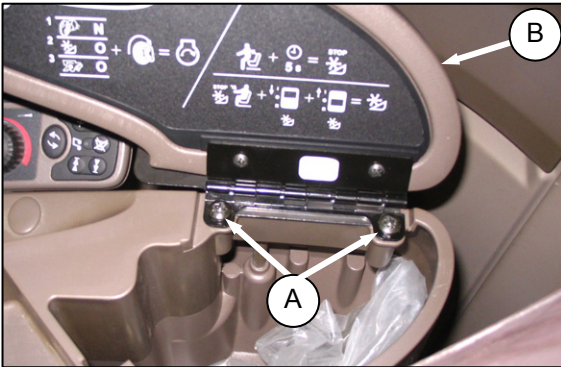

2. Remove the two screws (A) attaching compartment cover (B) to the console and remove cover.

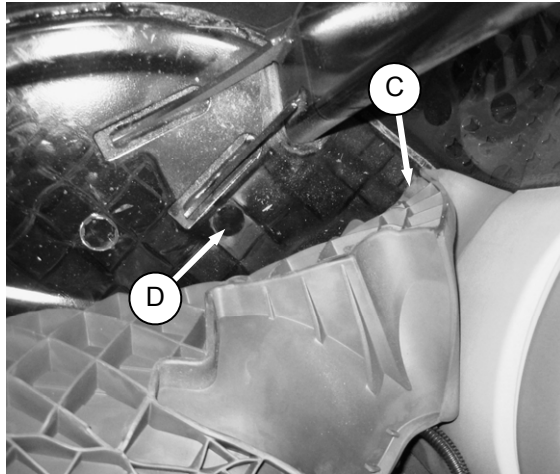

3. Lift floor mat (C) at forward right corner to expose knockout (D). Prop the floor mat for access to the knockout.
 4. Remove the knockout (D).

2. Retrieve switch, harness, and support from bag that was removed in **STEP 6A**.

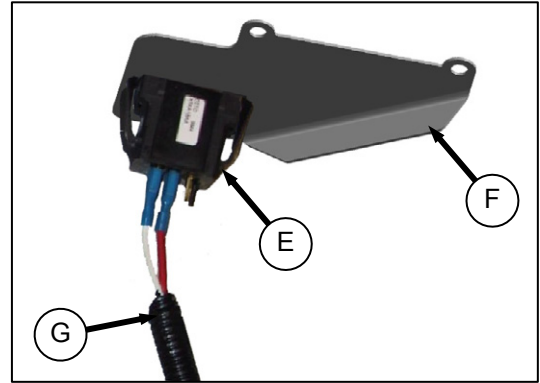

3. Install switch (E) into support (F) from the top. Ensure lugs on underside of support have secured switch.

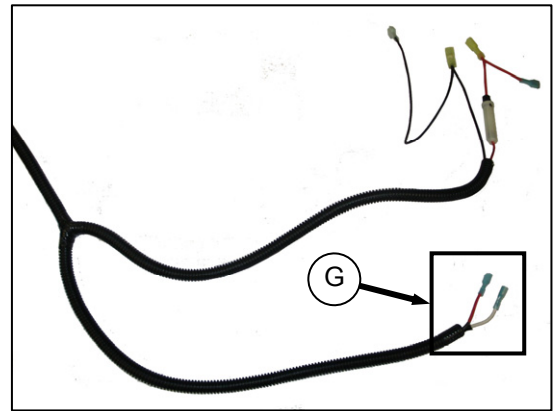

4. Connect switch end (G) of harness to switch (E) with red wire to center terminal, and white to either outer terminal.

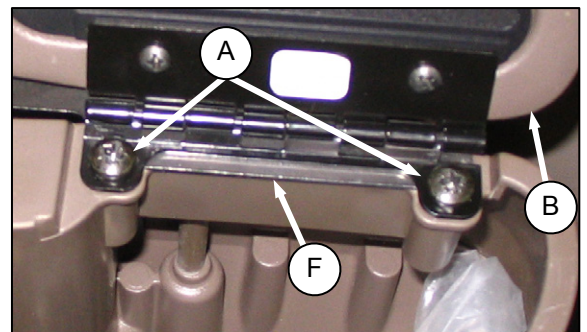

5. Position support (F) onto console and align holes in support with holes in console.
 6. Re-install cover (B) with existing screws (A).

(continued next page)

UNLOADING AND ASSEMBLY



- g. Close cover and check security of switch (E) and support (F).

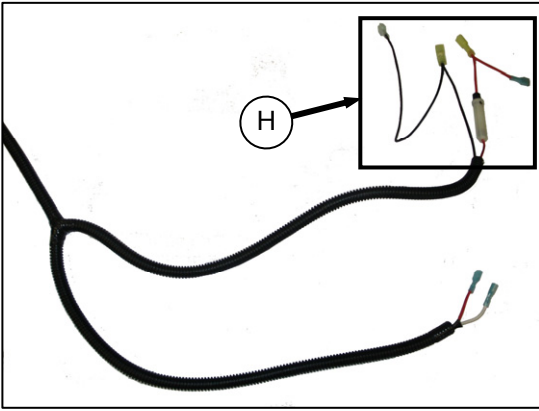

- h. Connect feed end (H) of harness to cigar lighter adapter (not shown).

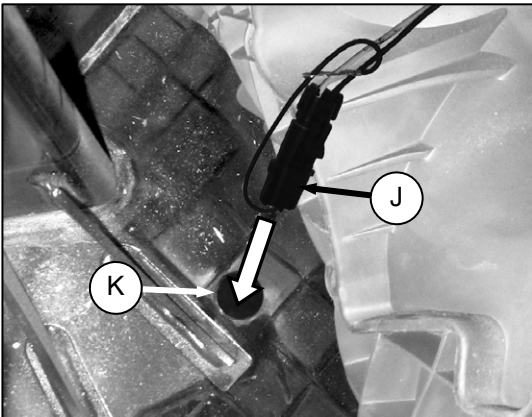

- i. Route plug end (J) of harness through hole (K) in cab floor and feed entire length to outside the cab. Leave some slack in the cab to allow for console adjustment.
- j. Replace floor mat.

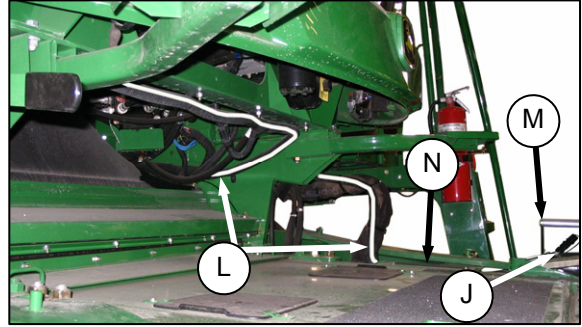

- k. Route harness (L) along existing hoses under the cab to left side of the feeder house and to the multi-coupler (M). Route harness under hose shield (N).
- l. Secure harness to hoses with plastic cable ties as required.

UNLOADING AND ASSEMBLY

II. ATTACH HEADER

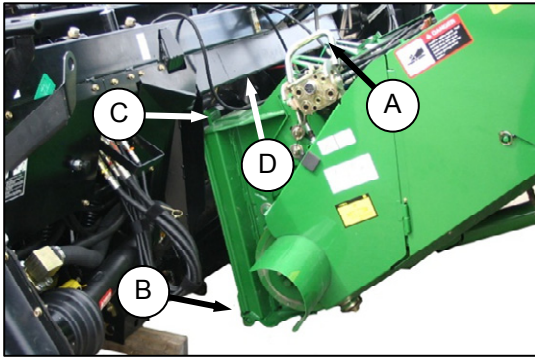

- Push handle (A) on combine coupler toward feeder house to retract pins (B) at bottom corners of feeder house.
- Slowly drive combine up to adapter until feeder house saddle (C) is directly under the adapter top cross member (D).
- Raise feeder house to lift adapter, ensuring feeder saddle is properly engaged in adapter frame.
- Raise or lower header until slightly off the ground.



CAUTION

Stop engine, and remove key from ignition before leaving Operator's seat for any reason. A child or even a pet could engage an idling machine.

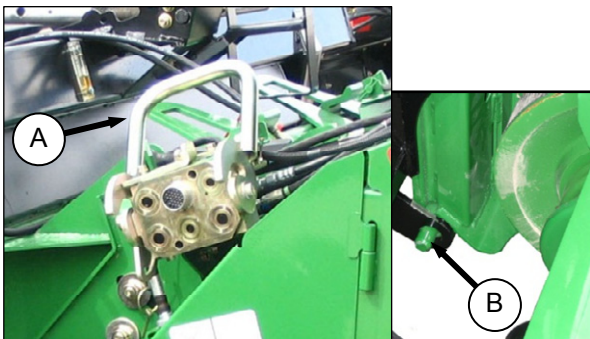

- Pull handle (A) to engage pins (B) in adapter.

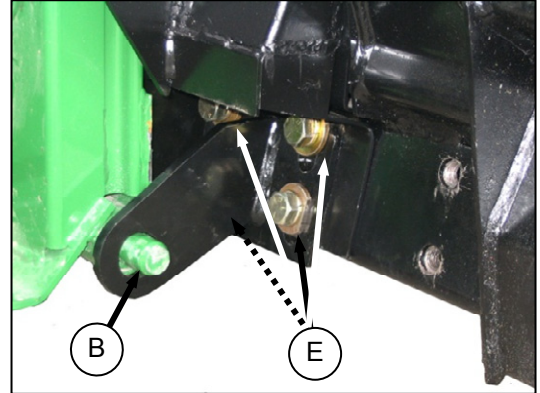

- Check that bolts (E) on adapter brackets are tight.
- If pins (B) do not fully engage adapter brackets, loosen bolts (E), and adjust bracket as required. Re-tighten bolts.
- Remove blocks from under cutterbar.
- Start engine, and lower header.

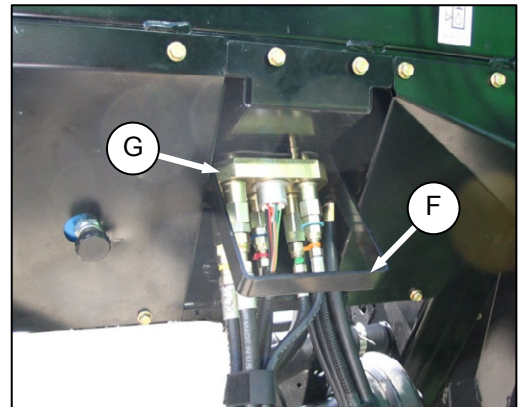

- Pull handle (F) on adapter to release coupler (G) from storage position. Remove coupler, and push handle back into adapter to store.

(continued next page)

UNLOADING AND ASSEMBLY

k. Attach coupler (G) to combine as follows:

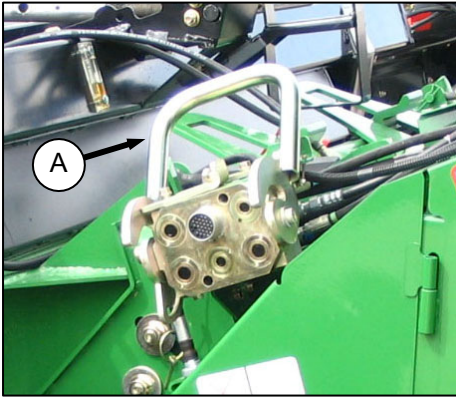

1. Handle (A) should be in the nearly up position. Clean receptacle.

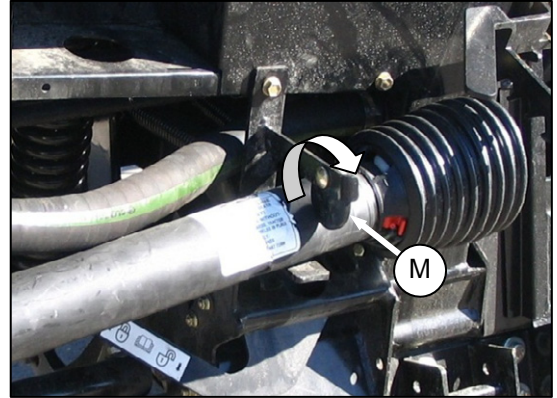

- m. Rotate disc (M) on adapter driveline storage hook, and remove driveline from hook.

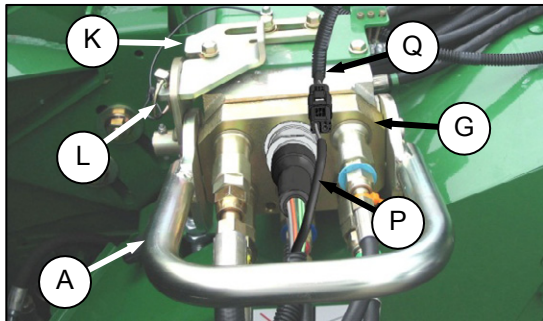

2. Locate coupler (G) onto receptacle, and pull handle (A) so that lugs on coupler are engaged into handle.
3. Pull handle to full horizontal position as shown.
4. Slide latch (K) to lock handle in position, and secure with lynch pin (L).
5. If adapter is equipped with reel fore-aft/header tilt selector, connect harness (P) to combine connector (Q).

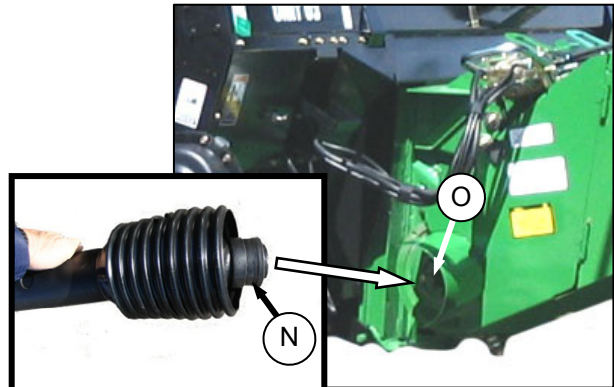

- n. Pull back collar (N) on end of driveline, and push onto combine output shaft (O) until collar locks.
- o. Proceed to **STEP 10. ATTACH CAM ARMS** (page 47).

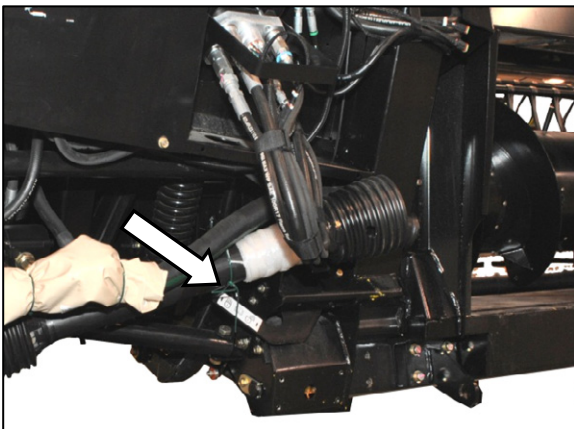

- l. Remove shipping wire from driveline and float lock lever.

UNLOADING AND ASSEMBLY

C. CAT LEXION 500, 700 SERIES

CAT Lexion 500(R), 700 Series Combines

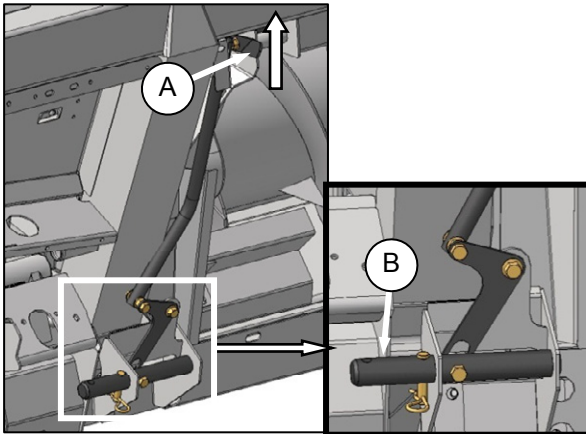

- a. Handle (A) on the adapter should be in raised position, and pins (B) at bottom corners of adapter retracted.
- b. Slowly drive combine up to adapter until feeder house is directly under the adapter top cross member.

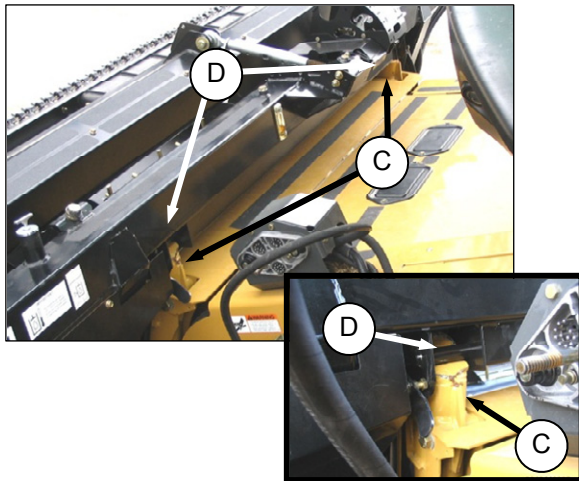

- c. Raise feeder house to lift adapter, ensuring feeder house posts (C) are properly engaged in adapter frame (D).
- d. Position header slightly off the ground.



CAUTION

Stop engine, and remove key from ignition before leaving Operator's seat for any reason. A child or even a pet could engage an idling machine.

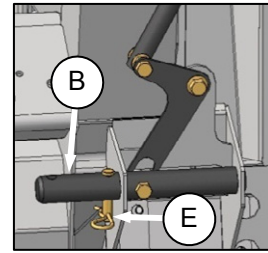

- e. Remove locking pin (E) from adapter pin (B).

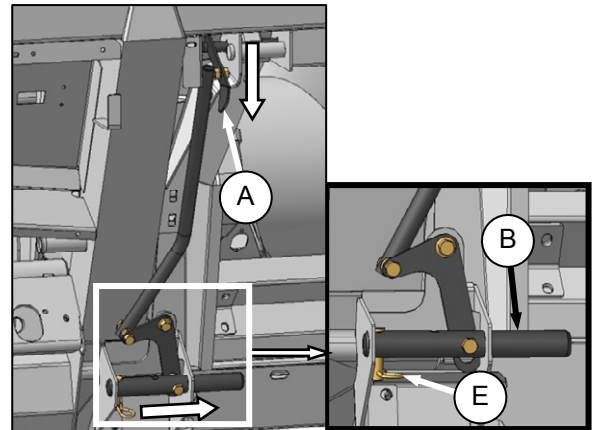

- f. Lower handle (A) to engage adapter pins into feeder house. Re-insert locking pin (E), and secure with hairpin.
- g. Remove blocks from under cutterbar.
- h. Start engine, and lower header. Shut down the combine.

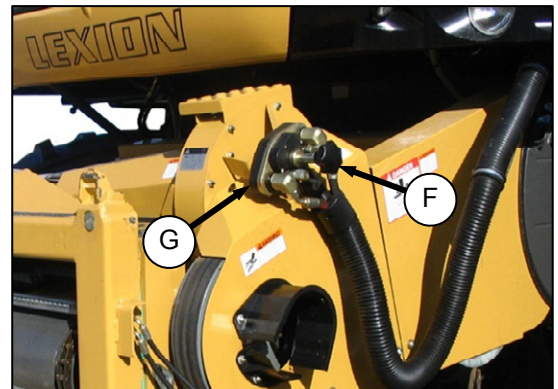

- i. Unscrew knob (F) on combine coupler (G) to release coupler from combine receptacle.

(continued next page)

UNLOADING AND ASSEMBLY

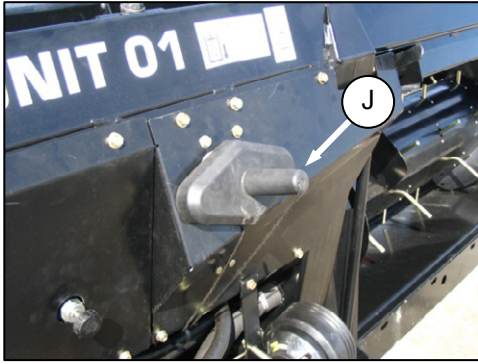

- j. Remove cover (J) from adapter receptacle.

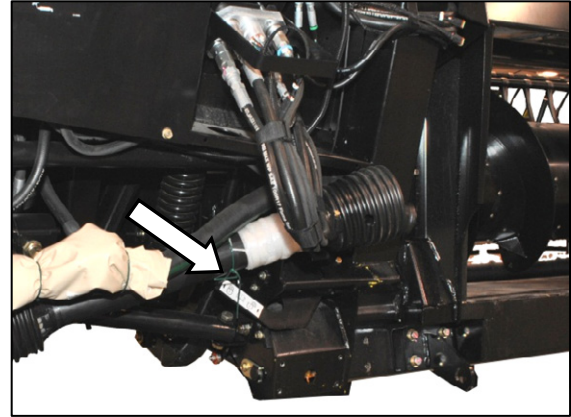

- p. Remove shipping wire from driveline and float lock lever.

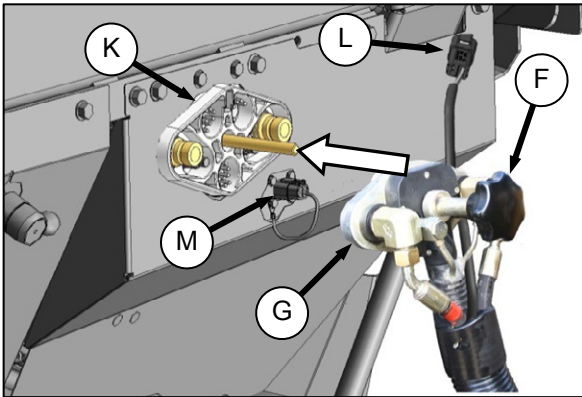

- k. Clean mating surface of coupler (G), and locate onto adapter receptacle (K).
 l. Turn knob (F) to secure coupler to receptacle.
 m. Connect combine harness (L) to reel fore-aft/header tilt selector receptacle (M).

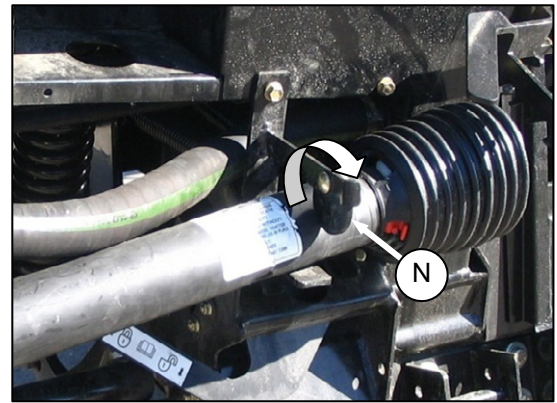

- q. Rotate disc (N) on adapter driveline storage hook, and remove driveline from hook.

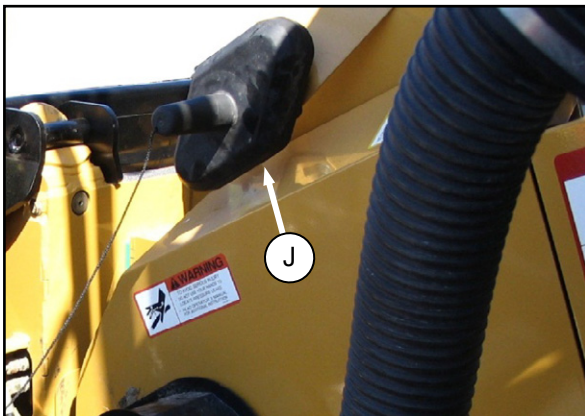

- o. Place cover (J) on combine receptacle.

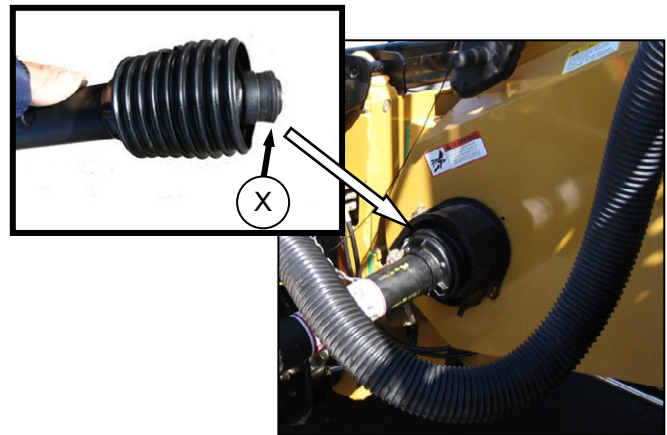

- r. Pull back collar (X) on end of driveline, and push onto combine output shaft until collar locks.
 s. Proceed to **STEP 10. ATTACH CAM ARMS** (page 47)

UNLOADING AND ASSEMBLY

D. NEW HOLLAND CR, CX SERIES

CR, CX Series

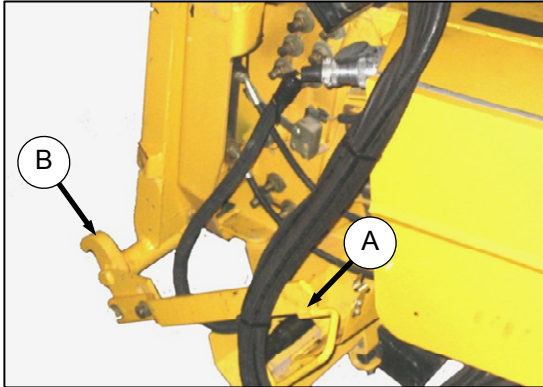

- a. Ensure handle (A) is positioned so that hooks (B) can engage adapter.

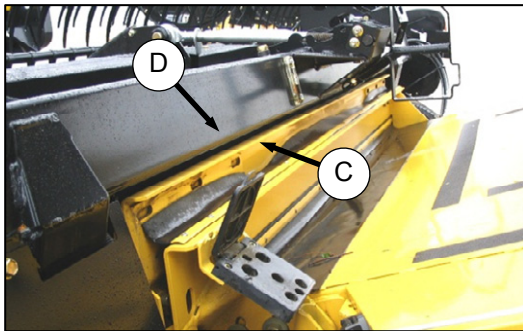

- b. Slowly drive combine up to adapter until feeder house saddle (C) is directly under the adapter top cross member (D).
- c. Raise feeder house to lift adapter, ensuring feeder saddle is properly engaged in adapter frame.



CAUTION

Stop engine, and remove key from ignition before leaving Operator's seat for any reason. A child or even a pet could engage an idling machine.

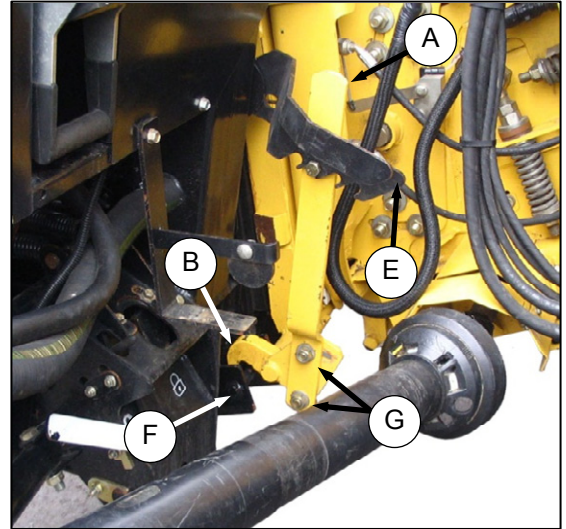

- d. Lift lever (E) on adapter at left side of feeder house, and push handle (A) on combine so that hooks (B) engage pins (F) on both sides of the feeder house.
- e. Push down on lever (E) so that slot in lever engages handle to lock handle in place.
- f. If hook (B) does not fully engage pin on adapter when (A) and (E) are engaged, loosen bolts (G), and adjust lock as required. Re-tighten bolts.

(continued next page)

UNLOADING AND ASSEMBLY

g. Connect to receptacle on adapter as follows:

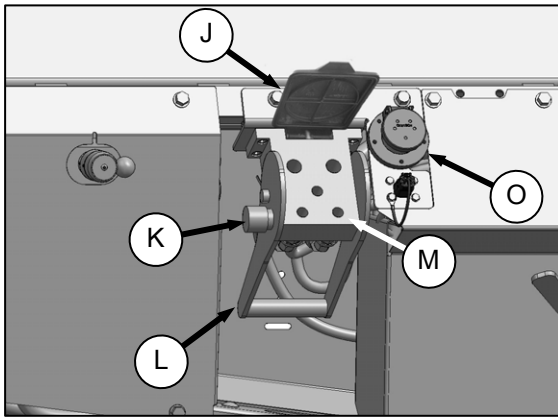

1. Open cover (J).
2. Push in lock button (K), and pull handle (L) halfway up to open position.

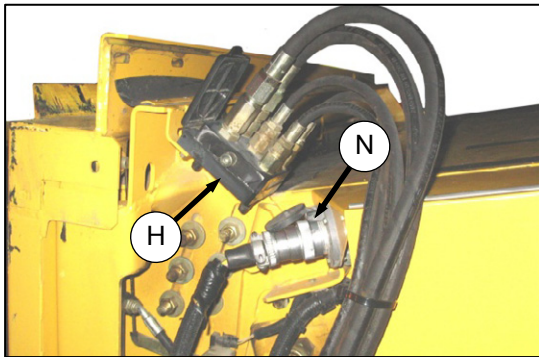

3. Remove hydraulic quick coupler (H) from storage plate on combine.

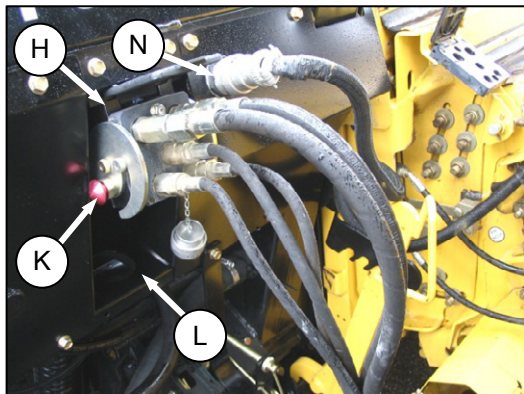

4. Position coupler onto adapter receptacle (M), and push handle (L) to engage pins into receptacle.
5. Push handle (L) to closed position until lock button (K) snaps out.

h. Attach combine electrical connector (N) to adapter as follows:

1. Remove cover on adapter electrical receptacle (O).

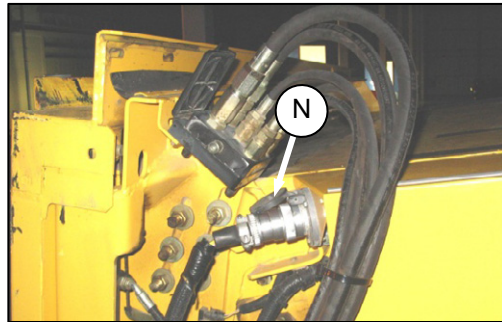

2. Remove connector (N) from combine.
3. Align lugs on connector (N) with slots in adapter receptacle (O), and push connector onto receptacle. Turn collar on connector to lock it in place.

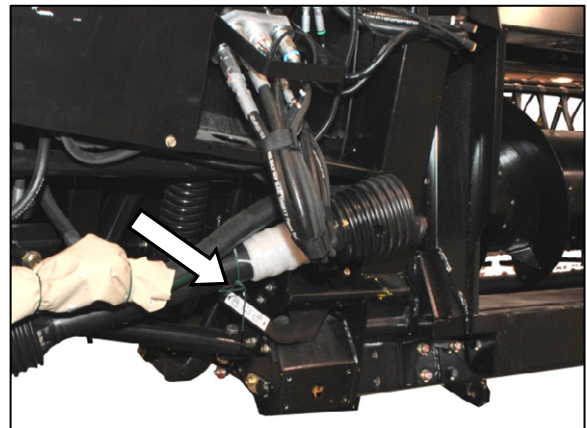

- i. Remove shipping wire from driveline and float lock lever.

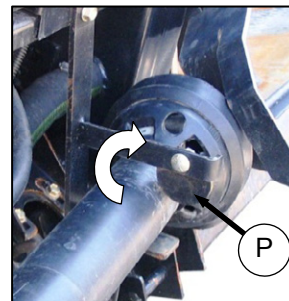

- j. Rotate disc (P) on adapter drive-line storage hook, and remove drive-line from hook.

(continued next page)

UNLOADING AND ASSEMBLY

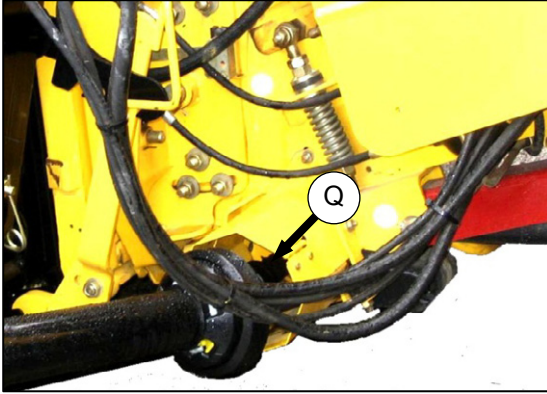

- k. Pull back collar on end of driveline, and push onto combine output shaft (Q) until collar locks.
- l. Proceed to **STEP 10. ATTACH CAM ARMS** (page 47).

UNLOADING AND ASSEMBLY

E. AGCO

Gleaner R Series and S Series
Challenger 660, 670, and 680B
Massey 9690, 9790, and 9895

ALL EXCEPT GLEANER 'R' & 'S' SERIES

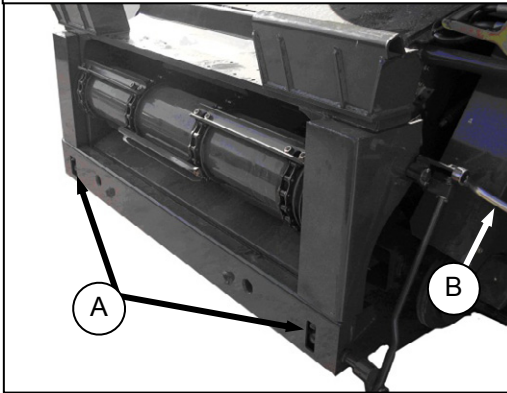

GLEANER 'R' & 'S' SERIES

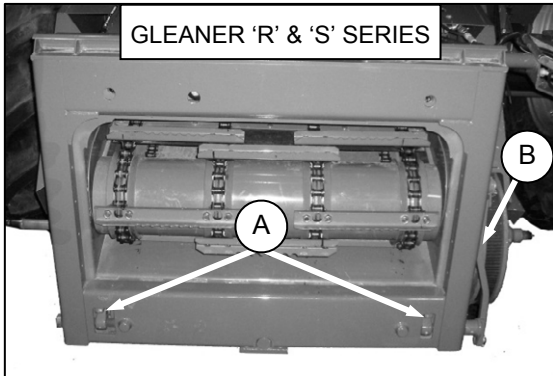

- a. Retract lugs (A) at base of feeder-house with lock handle (B).

EXCEPT GLEANER 'R' & 'S' SERIES
and 'LL' MODEL

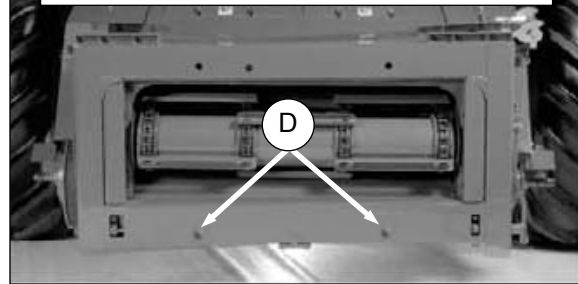

GLEANER 'R' & 'S' SERIES

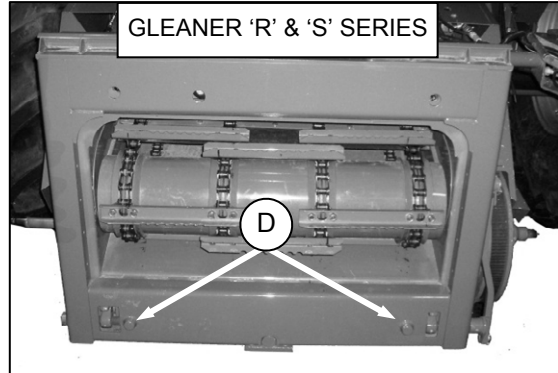

'LL' MODEL

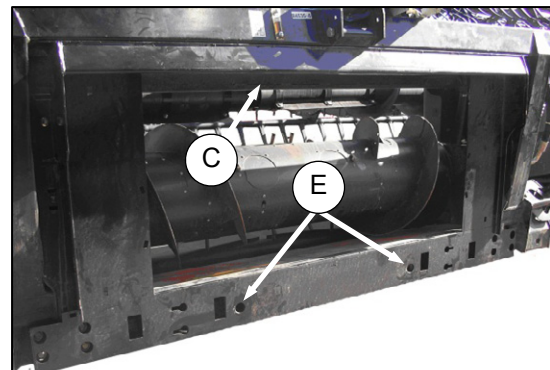
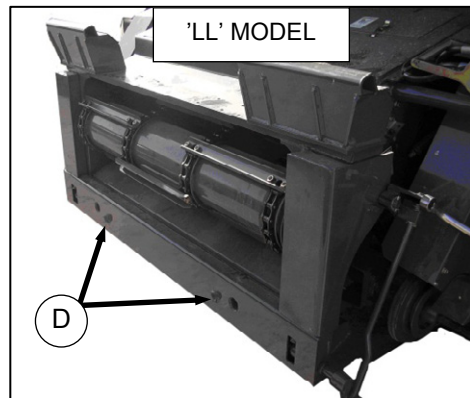

- b. Slowly drive combine up to adapter until feeder house is directly under the adapter top cross member (C), and alignment pins (D) are aligned with holes (E) in adapter frame.

(continued next page)

UNLOADING AND ASSEMBLY

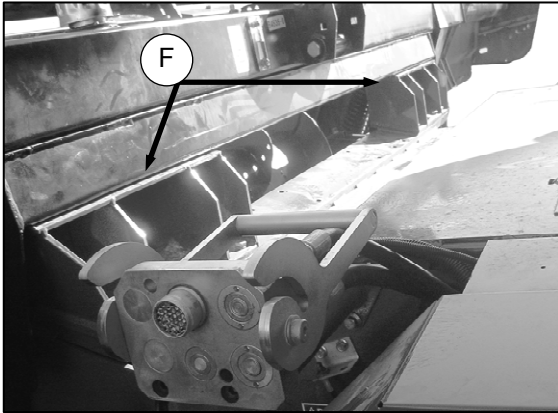

- c. Raise feeder house to lift adapter, ensuring feeder house saddle (F) and alignment pins are properly engaged in adapter frame.
- d. Raise header slightly off the ground.



CAUTION

Stop engine, and remove key from ignition before leaving Operator's seat for any reason. A child or even a pet could engage an idling machine.

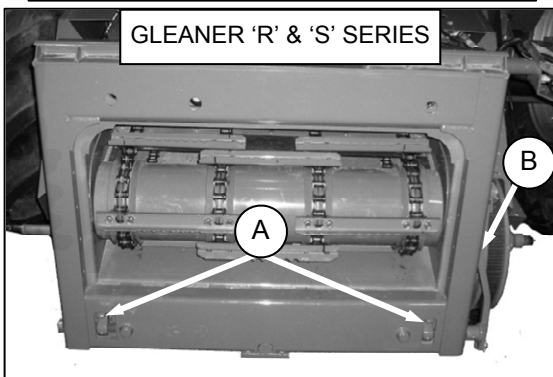
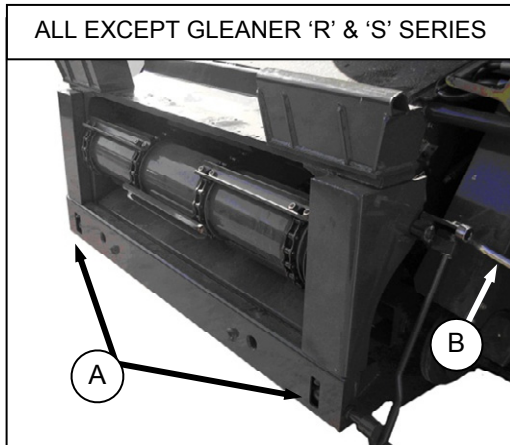

- e. Engage lugs (A) with adapter using lock handle (B).

- f. Remove blocks from under cutterbar.
- g. Start engine, and lower header. Shut down the combine.

NOTE

The CA25 Combine Adapter is equipped with a multi-coupler that connects to the combine. If your combine is equipped with individual connectors, a multi-coupler kit (single-point connector) must be installed.

The kits are available through your AGCO Dealer, and include installation instructions.

COMBINE	AGCO KIT #
Challenger	71530662
Massey	71411594
Gleaner R/S Series	71414706

- h. Connect adapter hydraulic quick coupler to combine receptacle as follows:

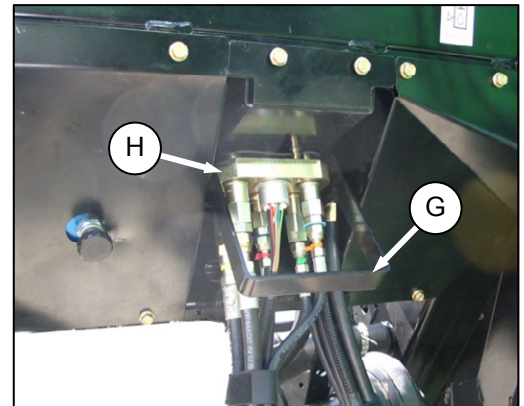

- 1. Raise handle (G) to release coupler (H) from adapter.

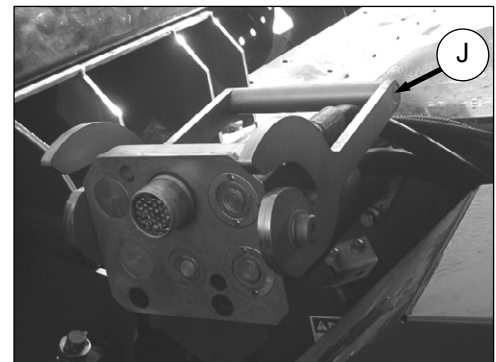

- 2. Push handle (J) on combine to full open position.

(continued next page)

UNLOADING AND ASSEMBLY

3. Clean mating surfaces of coupler and receptacle if necessary.

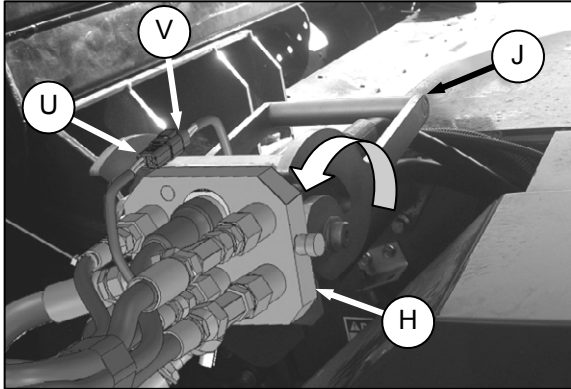

4. Position coupler (H) onto combine receptacle, and pull handle (J) to fully engage coupler into receptacle.
5. Connect reel fore-aft/header tilt selector harness (U) to combine harness (V).

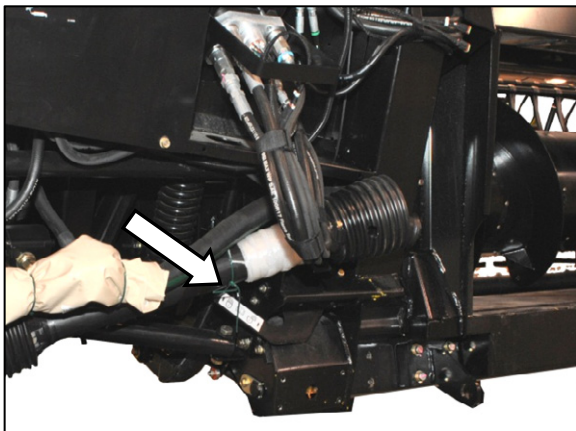

- i. Remove shipping wire from driveline and float lock lever.

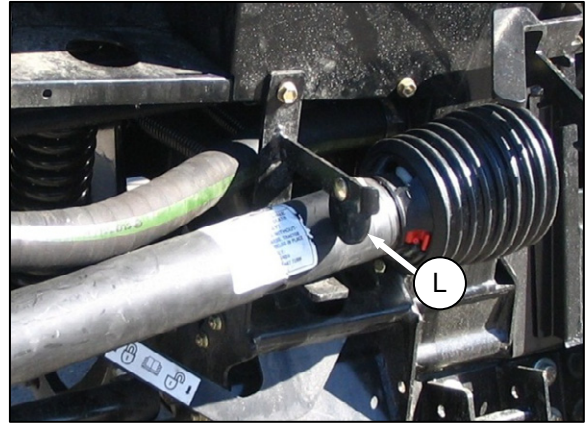

- k. Rotate disc (L) on adapter driveline storage hook, and remove driveline from hook.

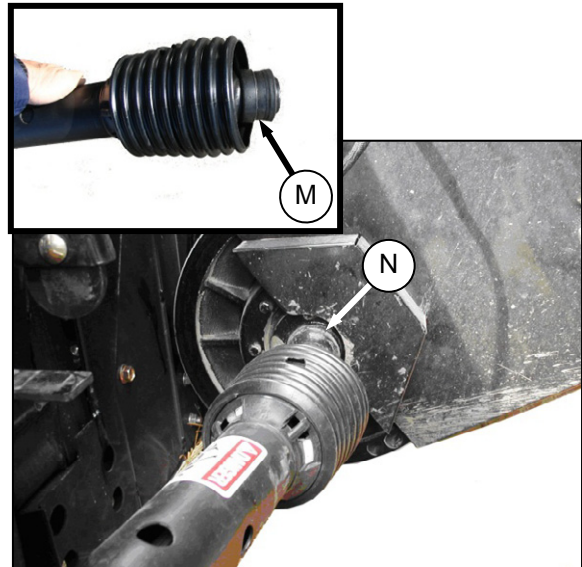

- l. Pull back collar (M) on end of driveline, and push onto combine output shaft (N) until collar locks.
- m. Proceed to **STEP 10. ATTACH CAM ARMS** (page 47).

UNLOADING AND ASSEMBLY

STEP 10. ATTACH CAM ARMS

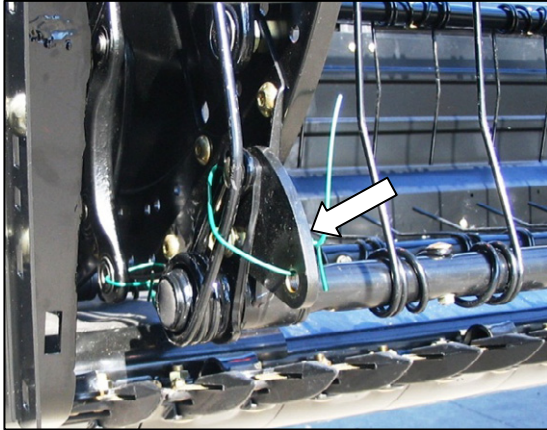

- a. Manually rotate reel until the tine bars with the disconnected cam links are accessible.
- b. Remove shipping wire (if not already removed).

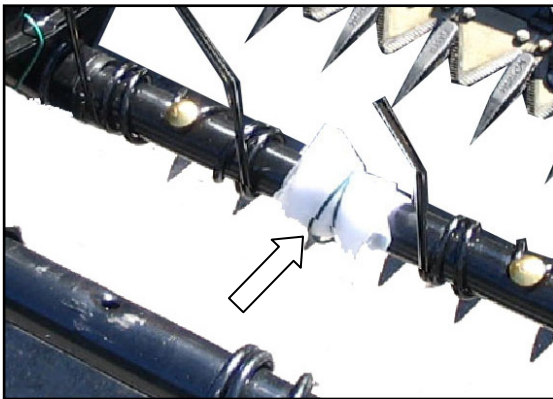

- c. Remove bag of hardware from tine bar. It contains hardware for cam links and endshields.

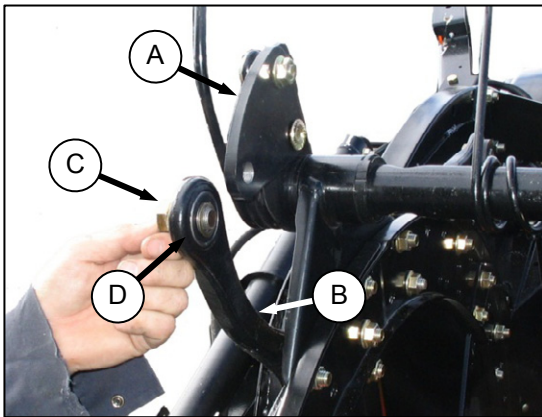

- d. Rotate tine bar crank (A), and position link (B) until attachment holes in bar crank and link are approximately aligned.

- e. Install bolt (C) in link, and position shim (D) on bolt so that shim is between link and tine bar crank.

NOTE

Bolts are pre-coated with Loctite[®], so no further locking method is required.

- f. Re-align link and tine bar crank, and thread in the bolt (C).
- g. Repeat for remaining tine bars, and torque bolts to 120 ft-lbf (165 N-m).

UNLOADING AND ASSEMBLY

STEP 11. REMOVE SHIPPING SUPPORTS

The removable supports are painted yellow. Refer to illustrations, and remove the remaining supports as follows:

NOTE

Unless otherwise specified, discard supports, and all shipping material and hardware.

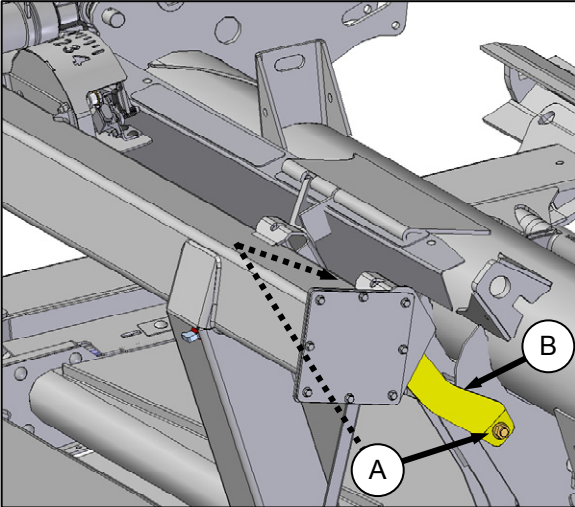

- a. Remove two bolts (A), and remove strap (B) from both sides of center frame.

NOTE

If strap is difficult to remove, lift on one end of header to release the load on the strap so that bolts can be removed.

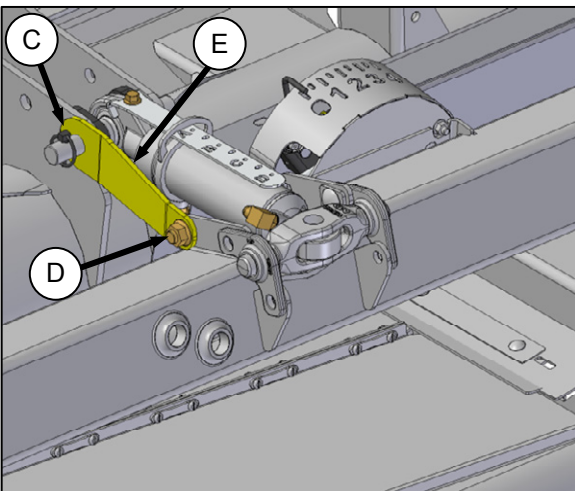

- b. Remove lynch pin (C), nut and bolt (D), and remove shipping brace (E).
- c. Re-install lynch pin (C).

STEP 12. POSITION TRANSPORT LIGHTS

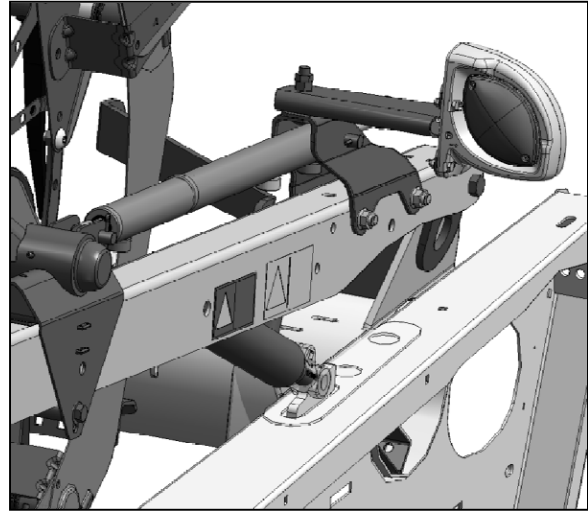

- a. Position light perpendicular to header. Lights are located on each of the outboard reel arms.

UNLOADING AND ASSEMBLY

STEP 13. INSTALL CROP DIVIDERS

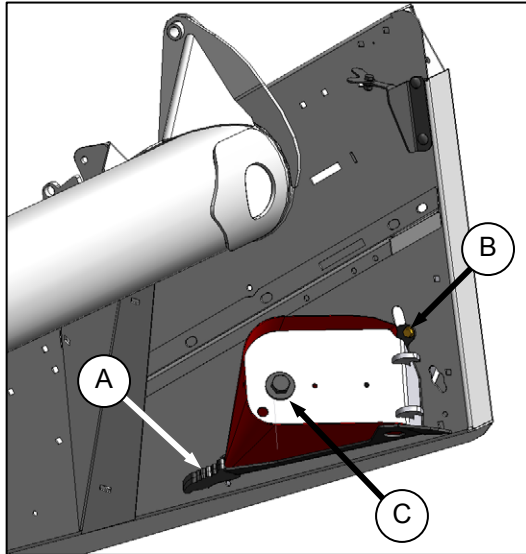

- a. Dividers are stored on inboard side of endsheets. To remove, support the divider and remove shipping wire at front end (A). Then, remove bolt (B).
- b. Remove bolt and washer at (C).

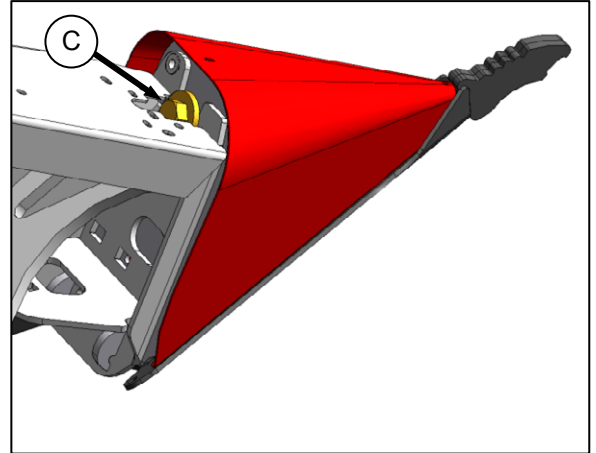

- d. Lift forward end of divider up to endsheet, and install washer and bolt at (C).

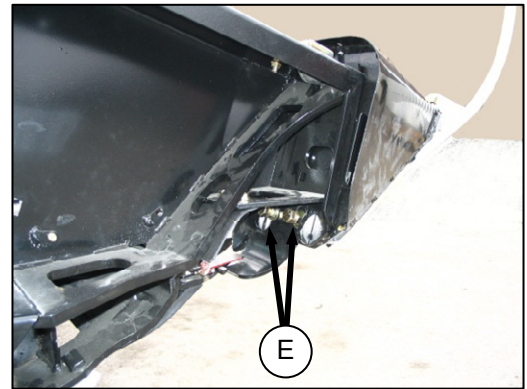

- e. Check that divider does not move laterally. Adjust bolts (E) as required to tighten divider, and remove lateral play when pulling at divider tip.

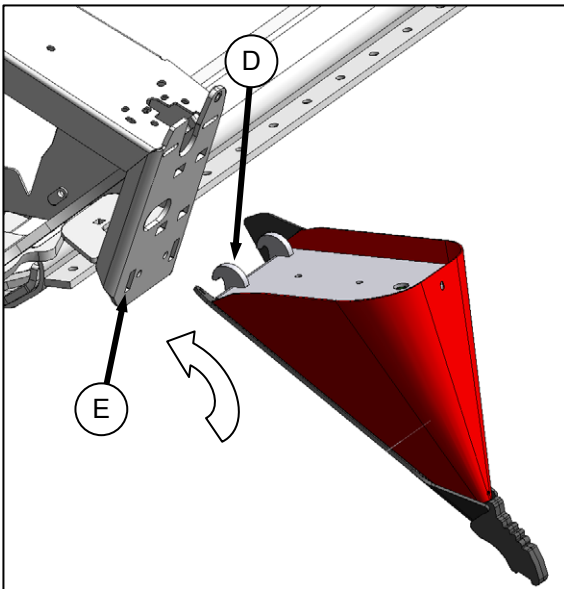

- c. Position crop divider as shown by locating lugs (D) in slots (E) in endsheet.

UNLOADING AND ASSEMBLY

STEP 14. TRIM DRAPER DEFLECTORS

Trim existing deflectors as follows:

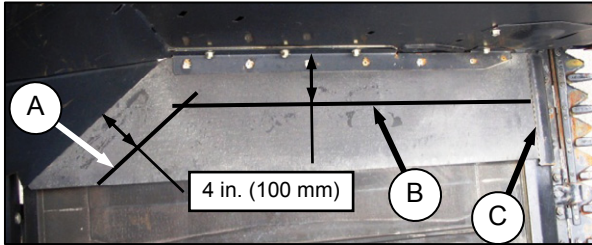

- Mark a straight line (A) on the deflector 4 in. (100 mm) from and parallel to the back edge of the deflector.
- Mark another line (B) on the deflector 4 in. (100 mm) from and parallel to the endsheet.
- Using a sharp knife, cut rubber deflector along the lines (A) and (B), taking care not to cut the draper underneath the deflector.
- Cut the rubber deflector along the steel retainer (C) from the inboard edge up to line (B), and remove the excess rubber.

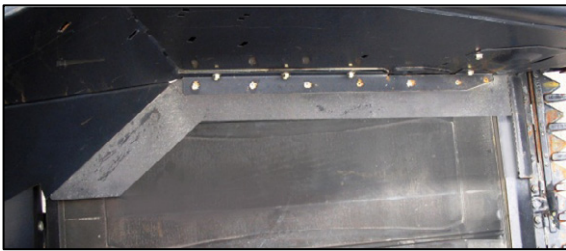

DEFLECTOR AFTER TRIMMING

- Use the cut-off portion of deflector as a template to re-work the deflector on the opposite end.

PRE-DELIVERY CHECKS

STEP 15. PRE-DELIVERY CHECKS



WARNING

Stop combine engine, and remove key before making adjustments to machine. A child or even a pet could engage the drive.

IMPORTANT

To avoid machine damage, check that no shipping dunnage has fallen into machine.

- a. Perform the final checks as listed on the **Pre-Delivery Checklist** (yellow sheet attached to this instruction) to ensure the machine is field-ready. Refer to following pages for detailed instructions as indicated on the Checklist.

IMPORTANT

The machine has been set at the factory, and should require no further adjustments. However, perform the following checks to ensure your machine will provide maximum performance. Adjustments should be made only if absolutely necessary, and in accordance with the instructions in this manual.

- b. The completed Checklist should be retained either by the Operator or the Dealer.

A. TIRE PRESSURE: TRANSPORT AND STABILIZER WHEEL OPTIONS

Check tire inflation pressure. If necessary, inflate as per following table:

SIZE	LOAD RANGE	PRESSURE
ST205/75 R15	D	65 psi (448 kPa)
	E	80 psi (552 kPa)

IMPORTANT

Do not exceed maximum pressure specified on tire sidewall.

B. WHEEL BOLT TORQUE: TRANSPORT AND STABILIZER WHEEL OPTIONS

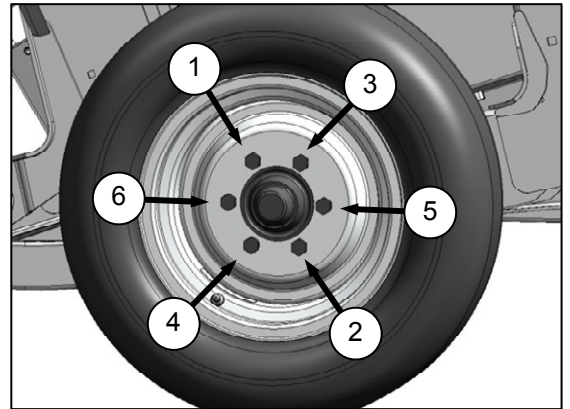

- a. Check wheel bolt torque is 80 - 90 ft·lbf (110 -120 N·m). Refer to bolt tightening sequence illustration above.

PRE-DELIVERY CHECKS

C. WOBBLE BOX

For access to wobble box(es), endshield(s) must be fully opened.

- a. To open endshield(s):

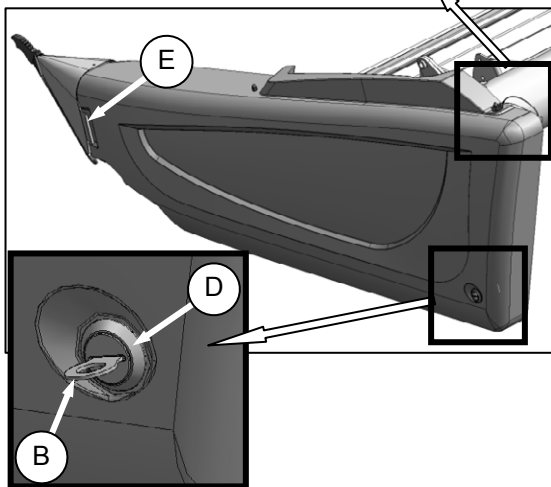
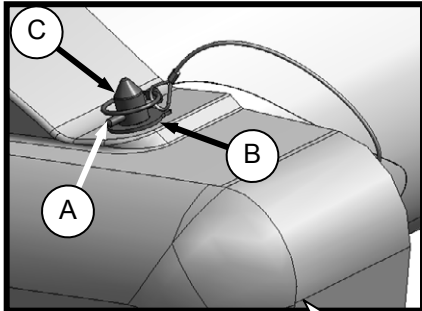

1. Remove lynch pin (A), and tool (B) from pin (C) at top rear of endshield.
2. Use tool (B) to unlock latch (D) at lower rear corner of endshield.
3. Lift shield at aft end to clear pin (C).
4. Swing shield out and away from header while maintaining forward pressure to prevent shield from slipping out of tab (E) at front of endsheet.
5. Carefully disengage front of shield from tab (E), and swing front of shield away from header.

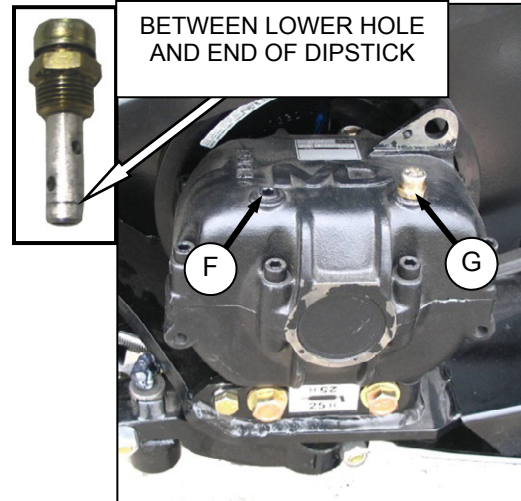

WOBBLE BOX (CHECK OIL LEVEL WITH TOP OF WOBBLE BOX HORIZONTAL)

- b. Position of plug (F) and breather (G) at wobble box must be as shown above.
- c. Check oil level.
- d. Leave endshield(s) open.

D. GEARBOX OIL

- a. Set cutterbar to working position.

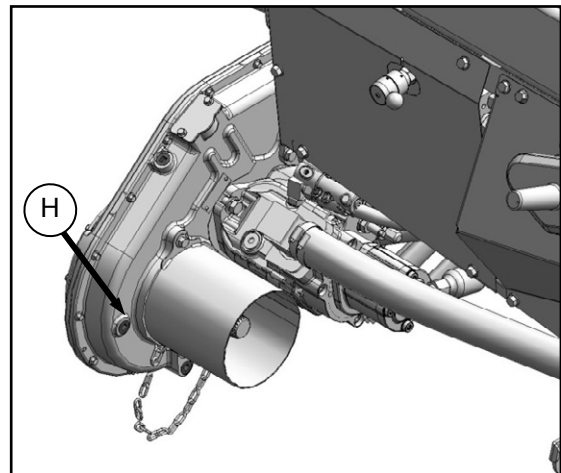

- b. Remove plug (H). Level should be to bottom of hole.

PRE-DELIVERY CHECKS

E. HYDRAULIC RESERVOIR

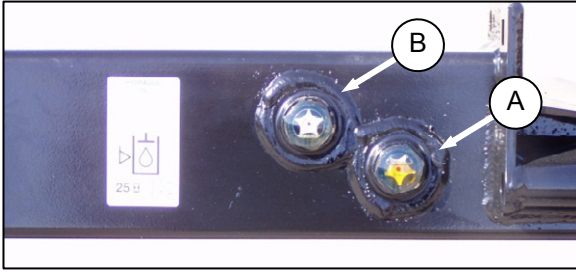

- a. Check oil level at sights (A) and (B) with cutterbar just touching ground. Check when oil is cold, and with center-link retracted.

Nominal: Normal Terrain: Maintain level so lower sight (A) is full, and upper sight (B) is empty.

NOTE

When ambient temperatures are above 95°F (35°C), to prevent overflow at breather under operating temperatures, it may be necessary to lower oil level slightly.

PRE-DELIVERY CHECKS

F. SICKLE BELT TENSION

I. NON-TIMED DRIVE: SK AND DK

- Open endshield(s).
- A force of 20 lbf (80 N) should deflect belt (A) 3/4 in. (18 mm) at mid-span.
- If necessary, adjust tension as follows:

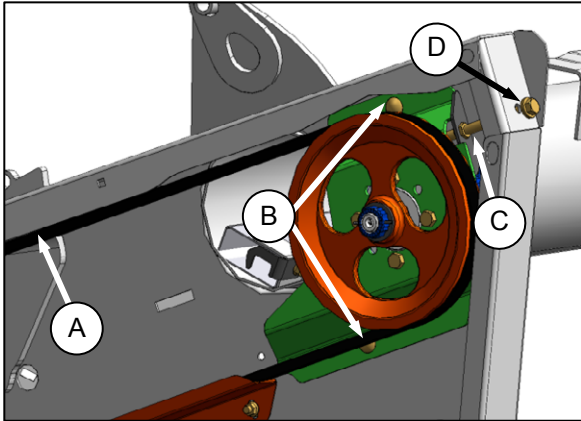

- Loosen two bolts (B) on sickle drive mounting bracket and jam-nut (C).
 - Turn adjuster bolt (D) to move drive motor until tension is achieved.
 - Tighten jam nut (C) and bolts (B) on drive mounting bracket.
- Close endshield(s).

II. TIMED DRIVE: DK

- Open endshield(s).

Timing Belts

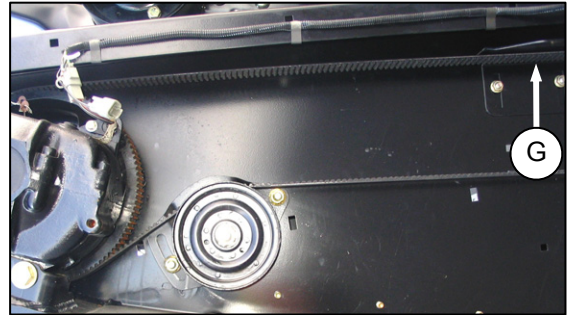

LH SHOWN - RH OPPOSITE

- A force of 6 lbf (27 N) should deflect timing belt (G) 1/2 in. (13 mm) at mid-span.
- Only if necessary, adjust tension as follows:

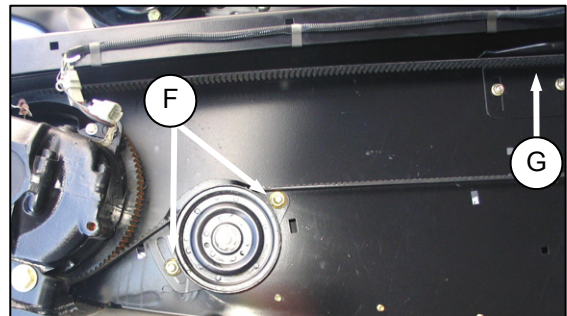

LH SHOWN - RH OPPOSITE

- Loosen two nuts (F) on sickle drive belt idler bracket.

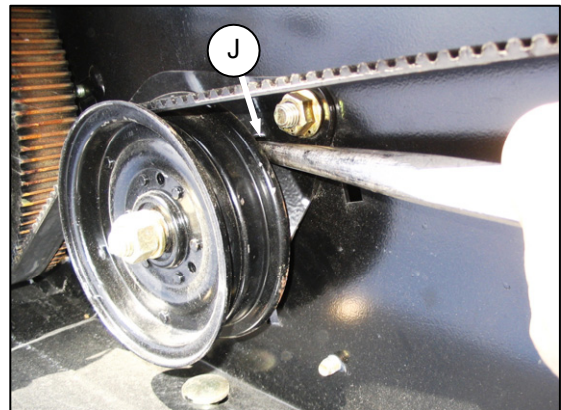

- Insert a long punch into hole (J) in idler bracket, and pry downward until a force of 6 lbf (27 N) deflects timing belt 1/2 in. (13 mm) at mid-span (G).
- Tighten nuts (F) on idler mounting bracket.

PRE-DELIVERY CHECKS

Double V-Belts: LH Side Only

1. A force of 12 lbf (53 N) should deflect V-Belts (K) 1/8 in. (3 mm) at mid-span.
2. Only if necessary, adjust tension as follows:

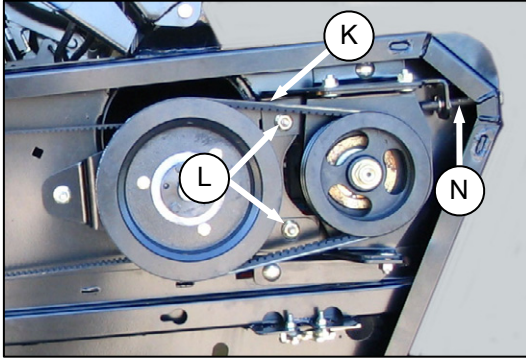

LH SIDE ONLY

- i Loosen two bolts (L) on sickle drive mounting bracket.

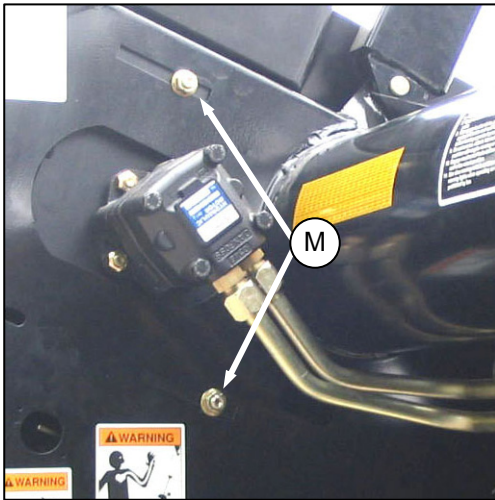

- ii Loosen two bolts (M) on endsheet.
 - iii Turn adjuster bolt (N) to move drive motor until a force of 12 lbf (53 N) deflects V-belts (K) 1/8 in. (3 mm) at mid-span.
 - iv Tighten bolts (L) and (M).
- b. Close endshield(s).

PRE-DELIVERY CHECKS

G. REEL CENTERING

- Start combine, and lower reel and header fully.



WARNING

Stop combine engine, and remove key before making adjustments to machine. A child or even a pet could engage the drive.

- Shut down engine, and remove key from ignition.
- Measure clearance between reel(s) and both endsheets. The clearances should be the same if the reel(s) are centered. If required, center the reels as follows:

I. DUAL REEL

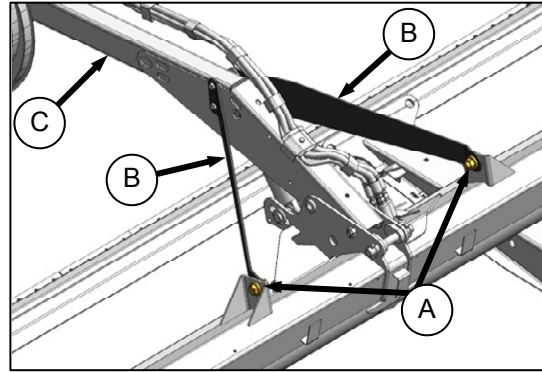

- Loosen bolt (A) on each brace (B).
- Move forward end of reel center support arm (C) laterally as required to center both reels.
- Tighten bolts (A), and torque to 265 ft·lbf (359 N·m).

II. SINGLE REEL

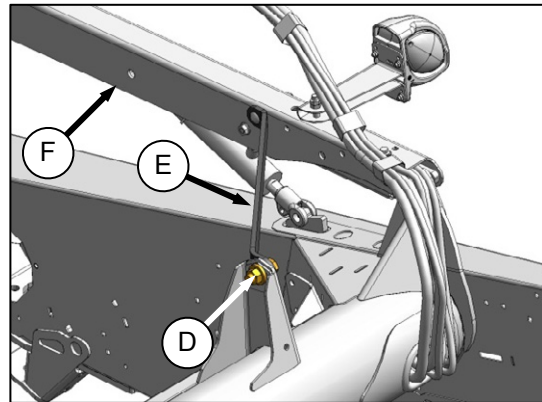

- Loosen bolt (D) on brace (E) at both ends of reel.
- Move forward end of reel support arm (F) laterally as required to center reel.
- Tighten bolts (D), and torque to 265 ft·lbf (359 N·m).

PRE-DELIVERY CHECKS

H. SIDE DRAPER TENSION

- a. Raise header, and shut down engine. Engage header lift props.



WARNING

Stop combine engine, and remove key before making adjustments to machine. A child or even a pet could engage the drive.



CAUTION

Engage header lift cylinder stops before working under header.

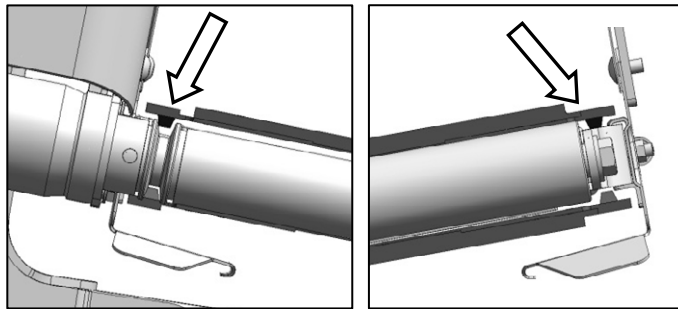

DRIVE ROLLER - ONE END IDLER ROLLER - BOTH ENDS

- b. Check that draper guide (the rubber track on underside of draper) is properly engaged in groove of drive roller, and that idler roller is between the guides.

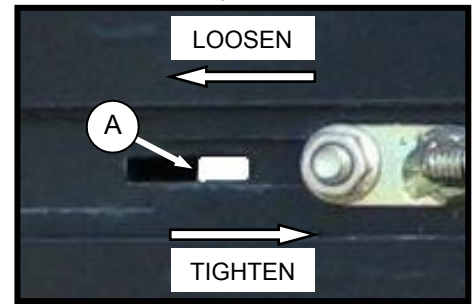
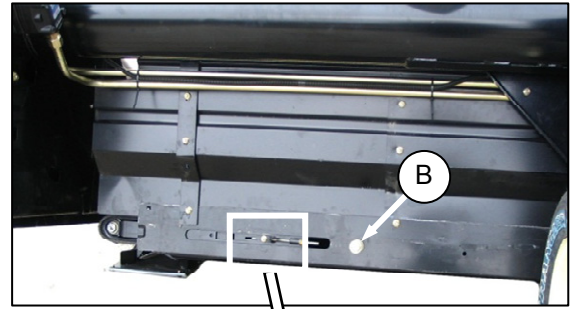

- c. Draper tension should be just enough to prevent slipping, and keep draper from sagging below cutterbar. The white bar (A) should be about halfway in the window.
- d. If required, set draper tension as follows:
1. **Turn bolt (B) clockwise (tighten)** and white indicator bar (A) will move inboard in direction of arrow to indicate that draper is tightening.
 2. **Turn bolt (B) counter clockwise (loosen)** and white indicator bar (A) will move outboard in direction of arrow to indicate that draper is loosening.
 3. Adjust until bar is about halfway in window.

PRE-DELIVERY CHECKS

I. CHECK HEADER FLOAT



CAUTION

Stop engine, and remove key from ignition before leaving Operator's seat for any reason. A child or even a pet could engage an idling machine.

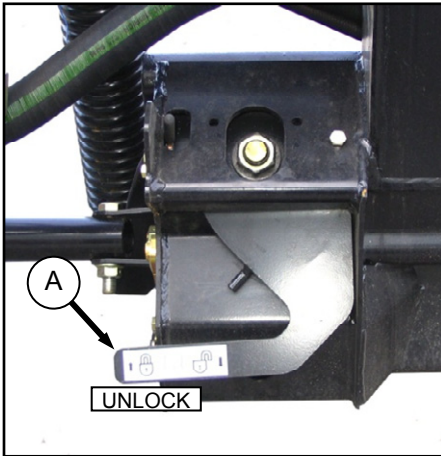

- a. Ensure both header float lock levers (A) are down (UNLOCK).

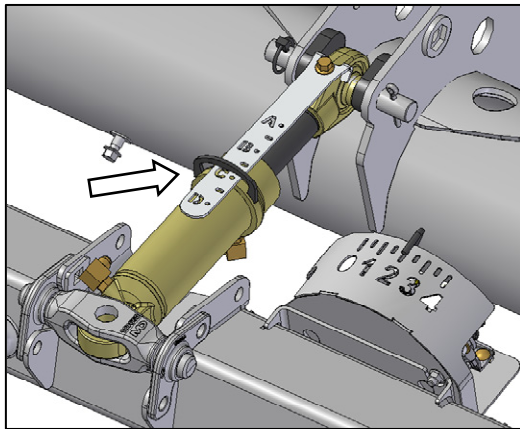

- b. Adjust center-link to mid-range (between B and C on cylinder indicator).
- c. Position cutterbar 8 to 12 in. (200 to 300 mm) off the ground.
- d. If header is equipped with stabilizer wheels or slow speed transport wheels, raise them off the ground so they are supported by the header.

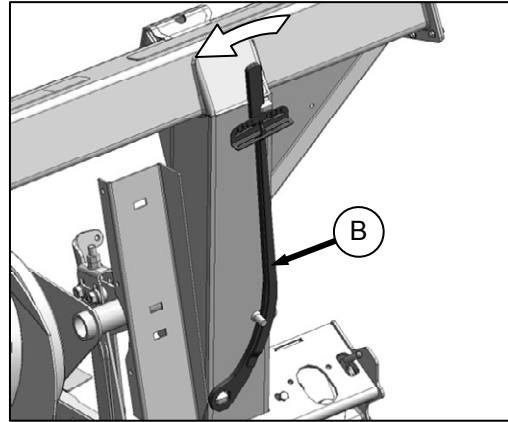

- e. Remove special torque wrench (B) from storage position at RH side of adapter frame. Pull slightly in direction shown to disengage wrench from hook.

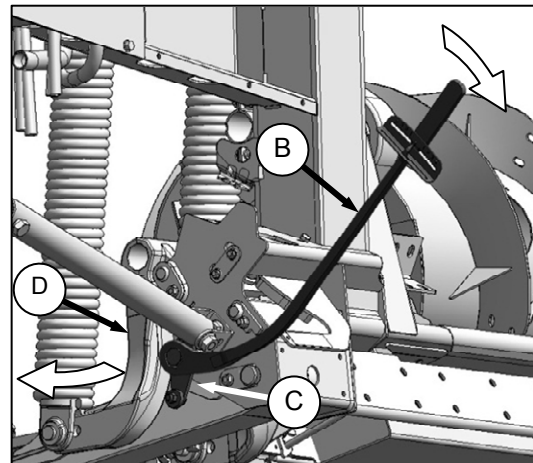

LEFT SIDE

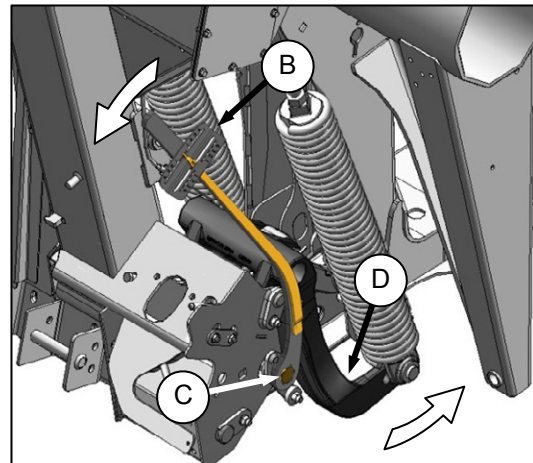

RIGHT SIDE

- f. Place torque wrench (B) onto hex (C) at side of float lock. Note position of wrench for checking RH or LH side.
- g. Push down on wrench to rotate bell crank (D) forward.

(continued next page)

PRE-DELIVERY CHECKS

NOTE

Loosen jam-nuts on adjuster bolts before adjusting and re-tighten once complete.

IMPORTANT

- **For Single Knife headers:** Adjust the float so the wrench reading is equal for both sides.
- **For 40 and 45 FT Double Knife headers:** Adjust the float so that wrench reading is equal for both sides, and then loosen **both** right hand springs **two turns**.

IMPORTANT

Turn each bolt pair equal amounts. After adjustment has been made, repeat torque wrench reading procedure.

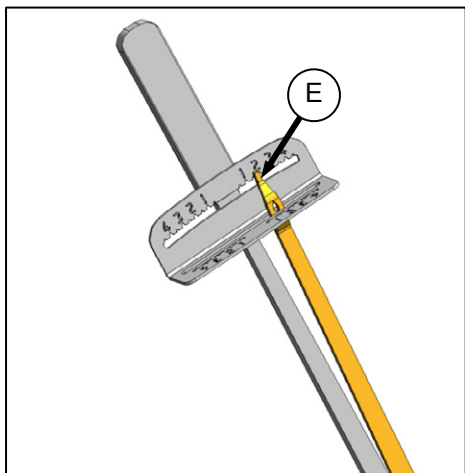

- h. Continue pushing down on the wrench until indicator (E) has reached a maximum reading, and started to drop off. Note the maximum reading. Repeat for opposite side.

Use the table below as a guide for float settings:

HEADER SIZE (FT)	TORQUE SETTINGS	
	CUTTING ON THE GROUND	CUTTING OFF THE GROUND
20, 25, 30, 35	1-1/2 to 2	2 to 2-1/2
40, 45	2 to 2-1/2	2-1/2 to 3

- i. If reading on wrench is **high**, header is **heavy**.
If reading on wrench is **low**, header is **light**.

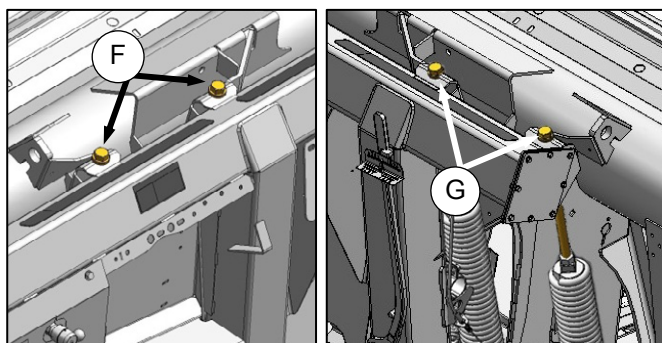

LEFT SIDE FLOAT

RIGHT SIDE FLOAT

1. To **increase** float (lighten the header), **tighten** bolts (F) and (G) at both sides of adapter.
2. To **decrease** float (increase header weight), **loosen** the bolts (F) and (G).

PRE-DELIVERY CHECKS

J. SKID SHOE SETTINGS

If skid shoes are installed, check and adjust if necessary as follows:



WARNING

Stop combine engine, and remove key before making adjustments to machine. A child or even a pet could engage the drive.



CAUTION

Engage header lift cylinder stops before working under header.

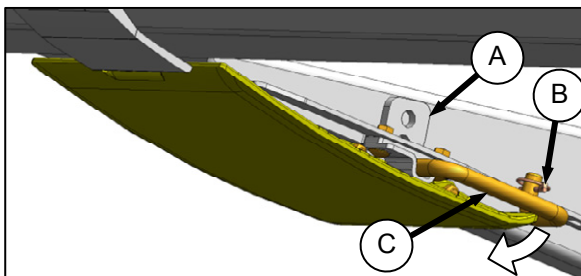

INNER SKID SHOE

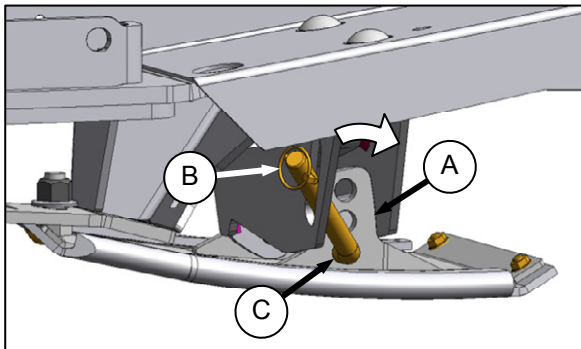

OUTER SKID SHOE

- a. Note the hole positions on the adjuster legs (A) on each skid shoe. They should be the same.
- b. If necessary, adjust as follows:
 1. Remove lynch pin (B).
 2. Hold shoe, and remove pin (C) by disengaging frame, and then pulling away from shoe.
 3. Raise or lower skid shoe to desired position using holes in support as a guide.
 4. Re-insert pin (C), engage in frame, and secure with lynch pin (B).
 5. Check that all skid shoes are adjusted to the same position.

PRE-DELIVERY CHECKS

K. REEL TINE TO CUTTERBAR CLEARANCE

The finger to guard/cutterbar clearances with reel fully lowered varies with header width, and are as follows. See illustration opposite.

HEADER	'X' +/- .12 in. (3 mm) @ REEL ENDS	
	SINGLE REEL	DUAL REEL
20 FT	.78 in. (20mm)	---
25 FT	1.00 in. (25 mm)	
30 FT	1.77 in. (45 mm)	0.78 in. (20 mm)
35 FT	2.36 in. (60 mm)	
40 FT	---	
45 FT	---	

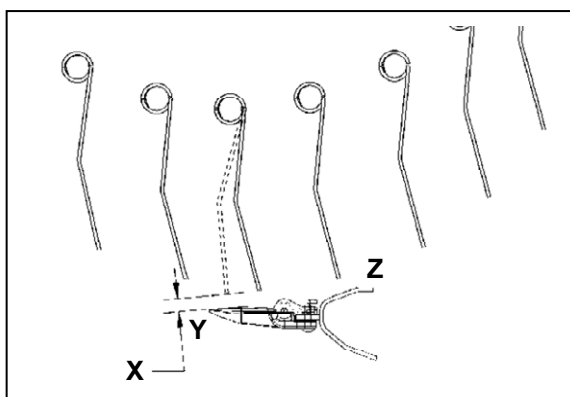

CAUTION

Engage header lift cylinder stops before working under header.

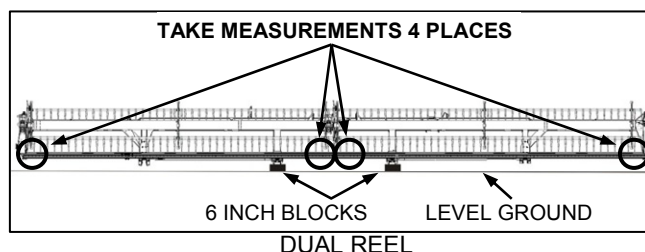
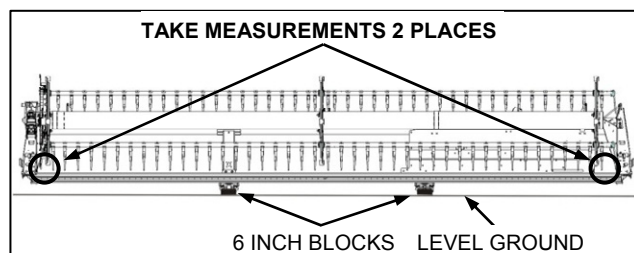

- a. Raise header, and place a 6 in. (150 mm) block under each inboard header leg.
- b. Lower header onto blocks, and fully lower the reel.

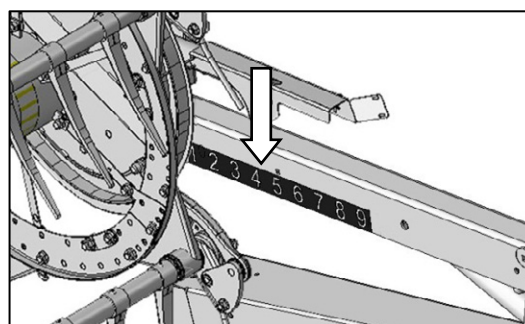

- c. Adjust fore-aft reel position so that back end of cam disc is approximately between 4 and 5 on the arm decal.
- d. Shut down combine, and remove key from ignition.
- e. Measure clearance at ends of each reel.

NOTE

The reel has been adjusted at the factory to provide more clearance at the center of the reel than at the ends ('frown') to compensate for reel flexing.

- f. Check all possible points of contact between points 'Y' and 'Z'. Depending on reel fore-aft position, minimum clearance can occur at guard tine, hold-down, or cutterbar.

(continued next page)

PRE-DELIVERY CHECKS

- g. If required, adjust outside reel arms as follows:



DANGER

Engage header lift cylinder stops before working under header.

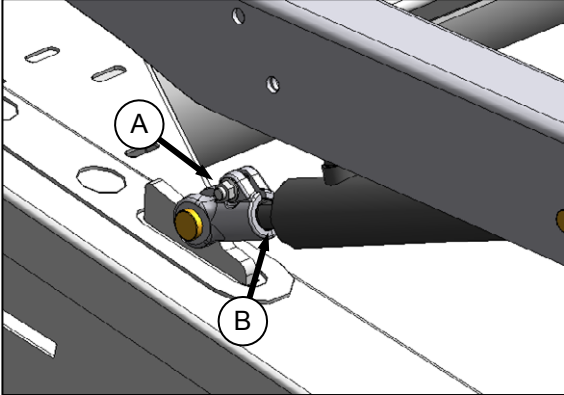

RH SHOWN - LH OPPOSITE

1. Loosen bolt (A).
 2. Turn cylinder rod (B) counter clockwise to raise reel and increase clearance to cutterbar, or clockwise to decrease.
 3. Tighten bolt (A).
 4. Repeat at opposite side.
- h. **For Dual Reel Only:** Adjust center arm to change clearance at center of cutterbar as follows:

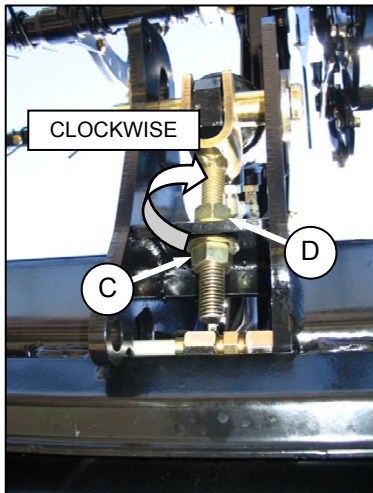

LOOKING UP AT ARM UNDERSIDE

1. Loosen nut (C).
2. Turn nut (D) counter clockwise to raise reel and increase clearance to cutterbar, or clockwise to decrease.
3. Tighten nut (C).

PRE-DELIVERY CHECKS

L. DRAPER SEAL

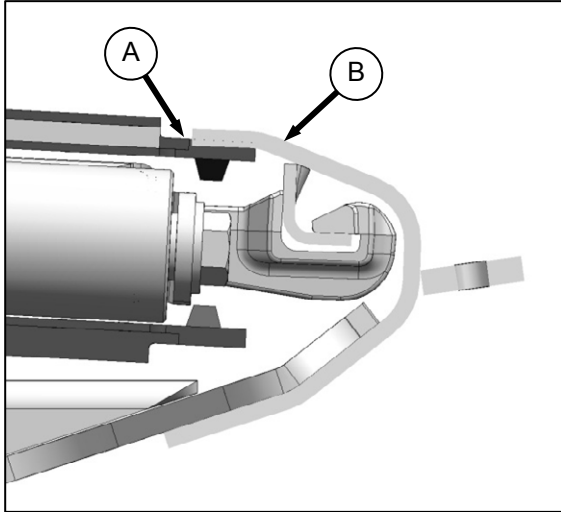

- a. Check deck height so that draper (A) runs just below cutterbar (B) with maximum 1/32 in. (1 mm) gap, or with draper deflected down slightly (up to 1/16 in. (1.5 mm)) to create a seal.

NOTE

Measurement is at supports with header in working position, and decks slid fully ahead.

- b. If deck height requires adjusting, proceed as follows:
 1. Loosen tension on draper. Refer to sub-step **H. DRAPER TENSION**.
 2. Lift draper up at front edge past cutterbar.

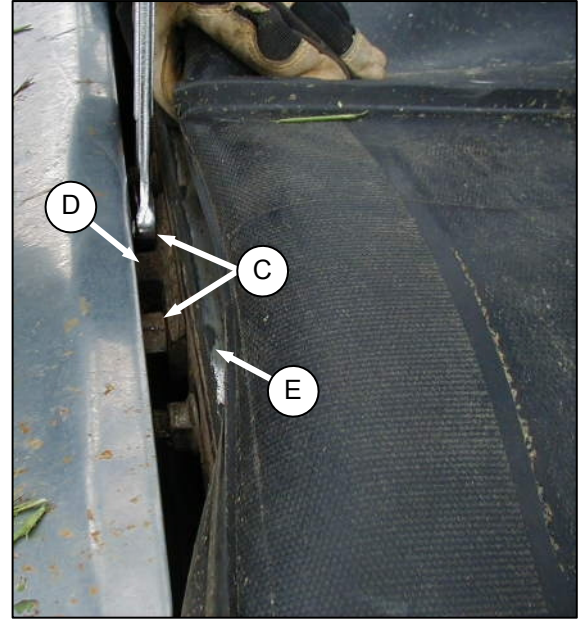

3. Loosen two lock-nuts (C) **one-half-turn only** on each deck support (D). There are two to four supports per deck, depending on header size.
4. Tap deck (E) to lower deck relative to supports to achieve the setting recommended above. Tap support (D) using a punch to raise deck relative to support.
5. Tighten deck support hardware (C).
6. Tension drapers. Refer to sub-step **H. DRAPER TENSION**.

PRE-DELIVERY CHECKS

M. LUBRICATE HEADER

Refer to master grease decals (shown opposite) provided on the header and adapter back frames, and use the illustrations on the following pages to identify the various locations requiring lubrication.

- Wipe grease fitting with a clean cloth before greasing, to avoid injecting dirt and grit.
- Inject grease through fitting with grease gun until grease overflows fitting, except where noted.
- Leave excess grease on fitting to keep out dirt.
- Replace any loose or broken fittings immediately.
- If fitting will not take grease, remove and clean thoroughly. Also clean lubricant passageway. Replace fitting if necessary.
- Use clean grease as specified (except where noted).

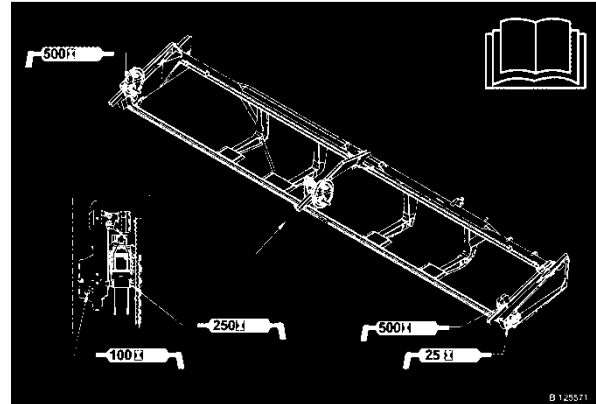

SINGLE KNIFE

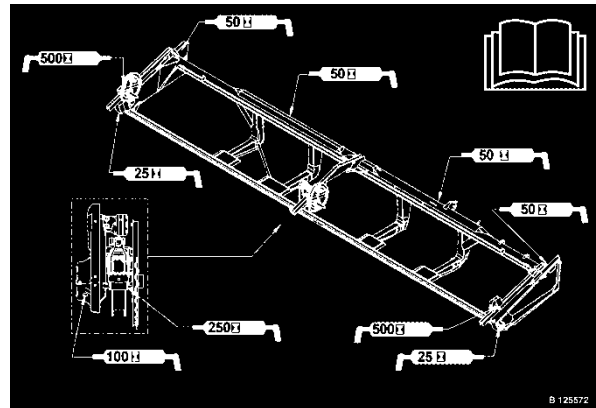

DOUBLE KNIFE

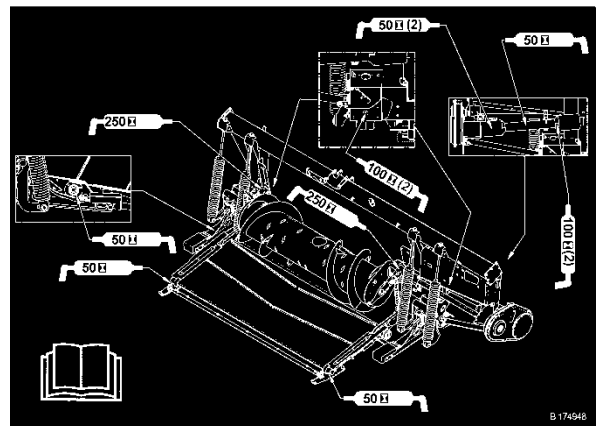

ADAPTER

PRE-DELIVERY CHECKS

Lubrication Points (cont'd)

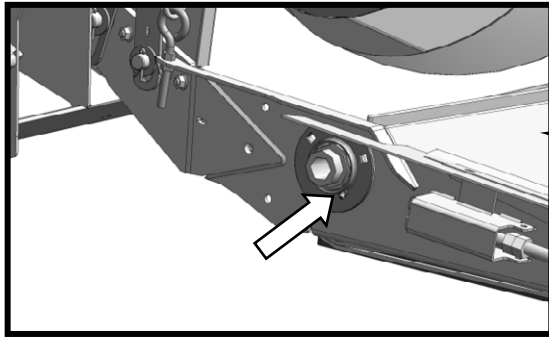

DRIVE ROLLER BEARING

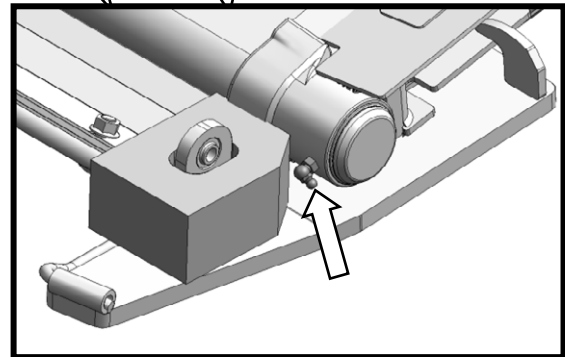
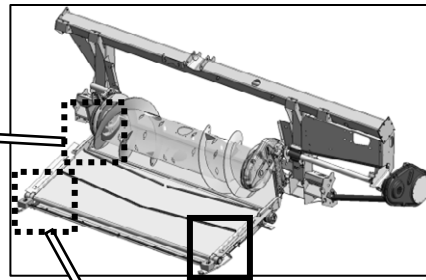

IDLER ROLLER - BOTH SIDES

High Temperature Extreme Pressure (EP2) Performance With 1% Max Molybdenum Disulphide (NLGI Grade 2) Lithium Base

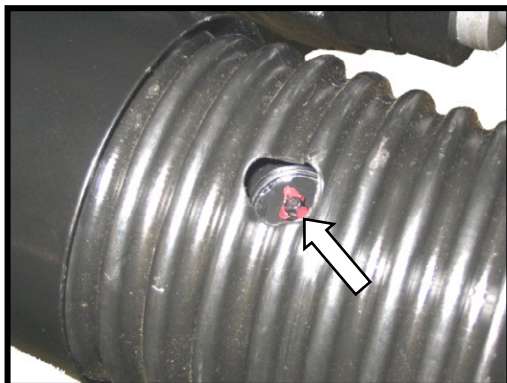
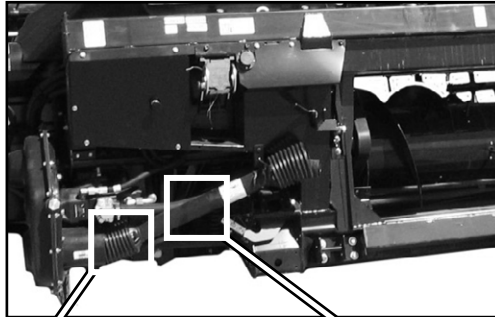

DRIVE UNIVERSAL - 2 PLCS

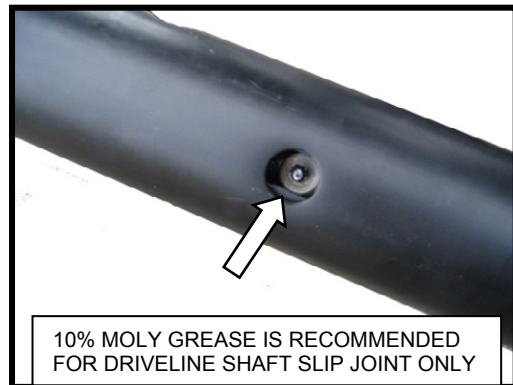

10% MOLY GREASE IS RECOMMENDED FOR DRIVELINE SHAFT SLIP JOINT ONLY

DRIVELINE SLIP JOINT

(continued next page)

PRE-DELIVERY CHECKS

Lubrication Points (cont'd)

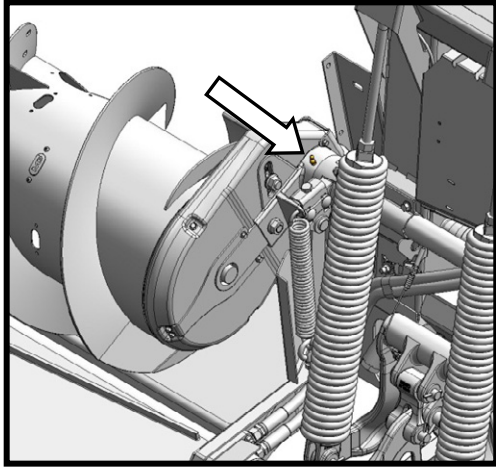

AUGER PIVOT

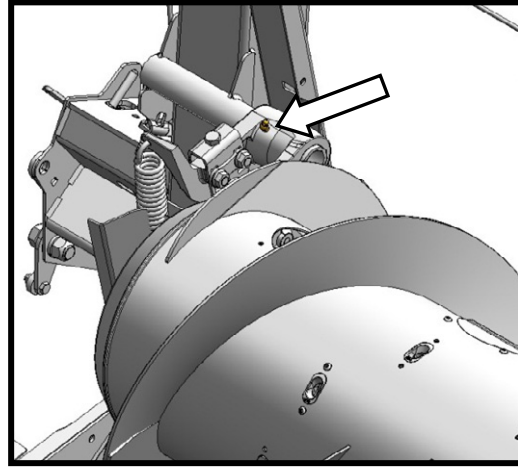

AUGER PIVOT

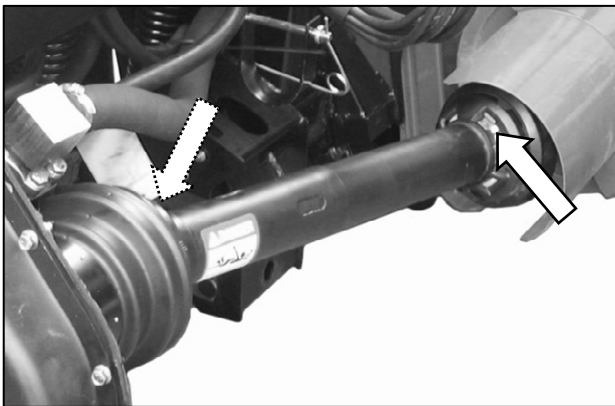
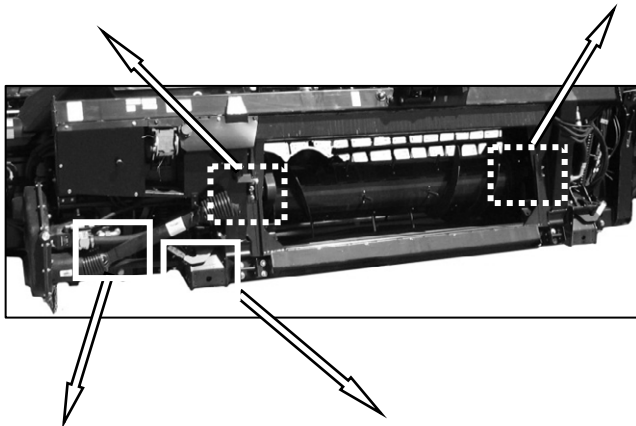

DRIVELINE GUARD - 2 PLCS

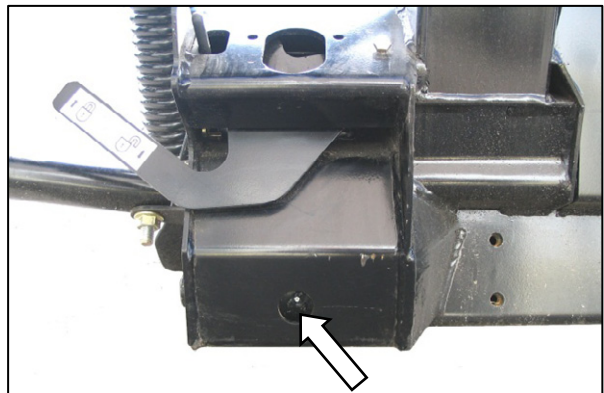

FLOAT PIVOT - 2 PLCS

(continued next page)

PRE-DELIVERY CHECKS

Lubrication Points (cont'd)

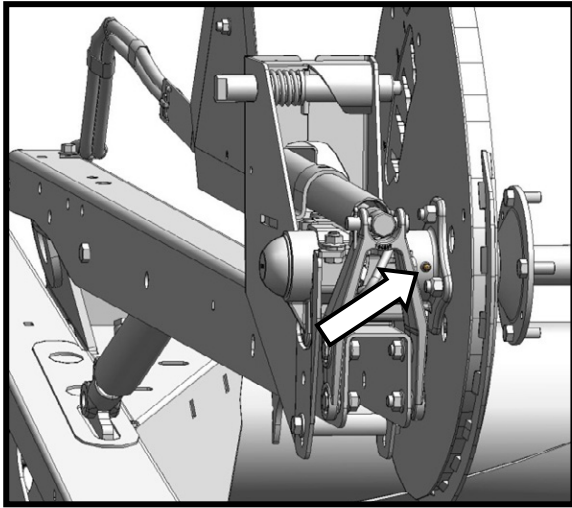

REEL SHAFT RH BEARING (1 PLC)

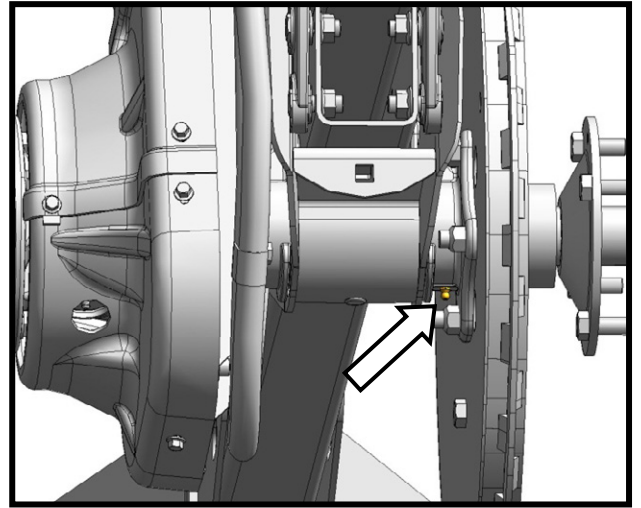

REEL CENTER BEARING (1 PLC) - DR ONLY

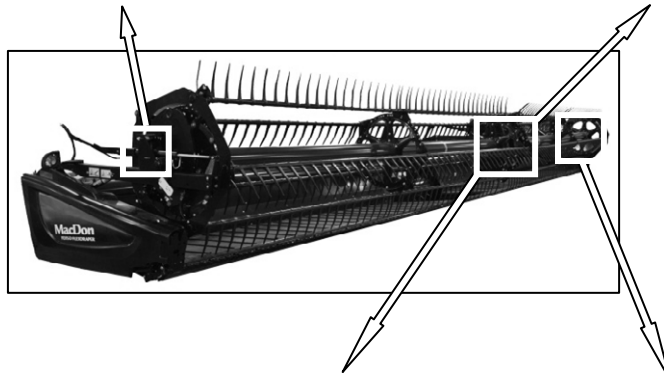

High Temperature Extreme Pressure (EP2) Performance With 1% Max Molybdenum Disulphide (NLGI Grade 2)

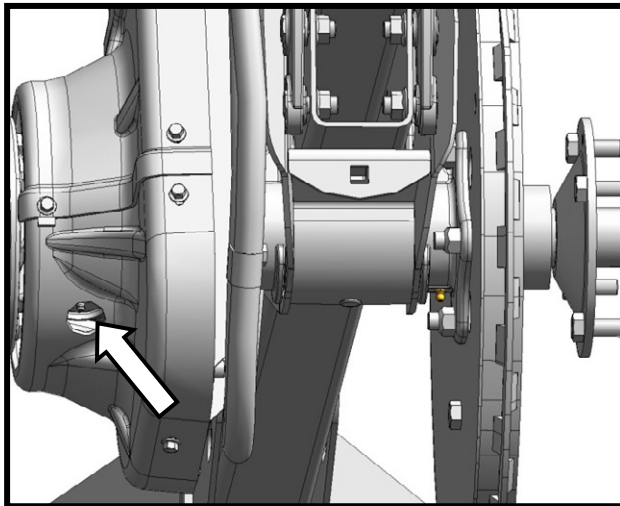
REEL UNIVERSAL (1 PLC) - DR ONLY

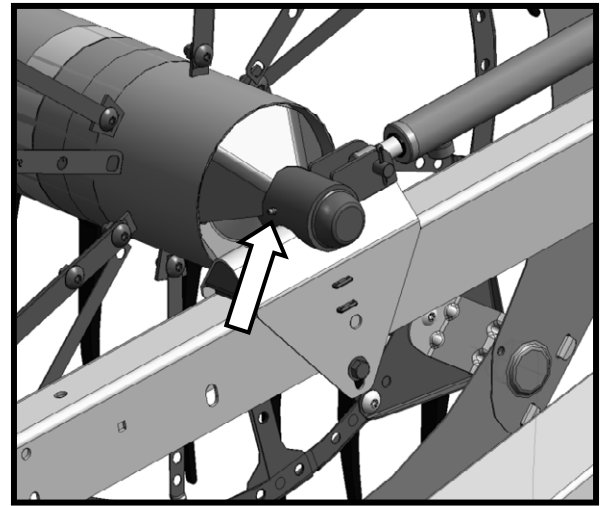

REEL SHAFT LH BEARING (1 PLC)

U-JOINT HAS AN EXTENDED LUBRICATION CROSS AND BEARING KIT. STOP GREASING WHEN GREASING BECOMES DIFFICULT OR IF U-JOINT STOPS TAKING GREASE. **OVERGREASING WILL DAMAGE U-JOINT.** 6 - 8 PUMPS IS SUFFICIENT AT FIRST GREASE (FACTORY). DECREASE GREASE INTERVAL AS U-JOINT WEARS AND REQUIRES MORE THAN 6 PUMPS.

(continued next page)

PRE-DELIVERY CHECKS

Lubrication Points (cont'd)

High Temperature Extreme Pressure (EP2) Performance With 1% Max Molybdenum Disulphide (NLGI Grade 2) Lithium Base

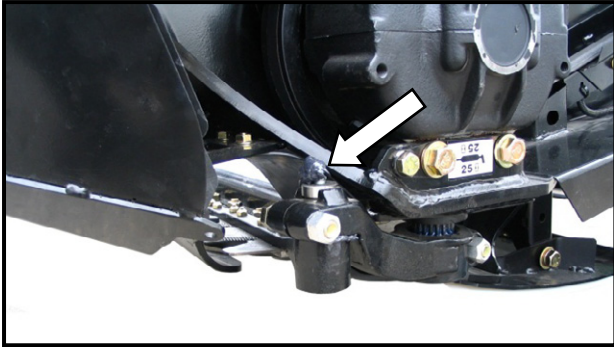

SICKLE HEAD
(SINGLE KNIFE - 1 PLC)
(DOUBLE KNIFE - 2 PLCS)



To prevent binding and/or excessive wear caused by sickle pressing on guards, do **not** over grease. If more than 6 to 8 pumps of the grease gun are required to fill the cavity, replace the seal in the sickle head.

Check for signs of excessive heating on first few guards after greasing. If required, relieve pressure by depressing check-ball in grease fitting.

PRE-DELIVERY CHECKS

N. ENDSHIELDS

NOTE

Plastic endshields are subject to expansion or contraction depending on large temperature variations. Position of top pin and lower catch can be adjusted to compensate for dimensional changes.

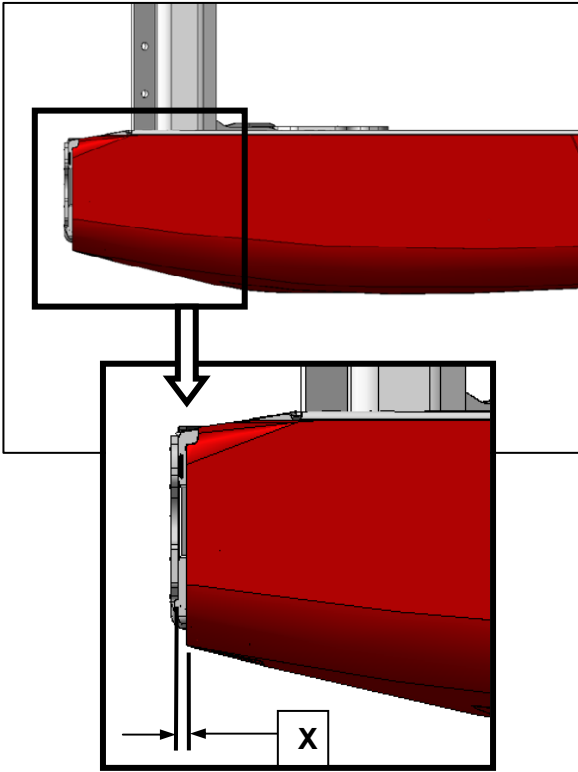

- a. Check gap 'X' between front end of shields and header frame, and compare against values in chart below.

TEMPERATURE Degrees °F (°C)	GAP 'X' Inches (mm)
25 (-4)	1.1 (28)
45 (7)	1.0 (24)
65 (18)	0.79 (20)
85 (29)	0.64 (16)
105 (41)	0.5 (12)
125 (52)	0.32 (8)
145 (63)	0.16 (4)
165 (89)	0

- b. If necessary, open endshield, and adjust the gap as follows:
1. Open endshield.

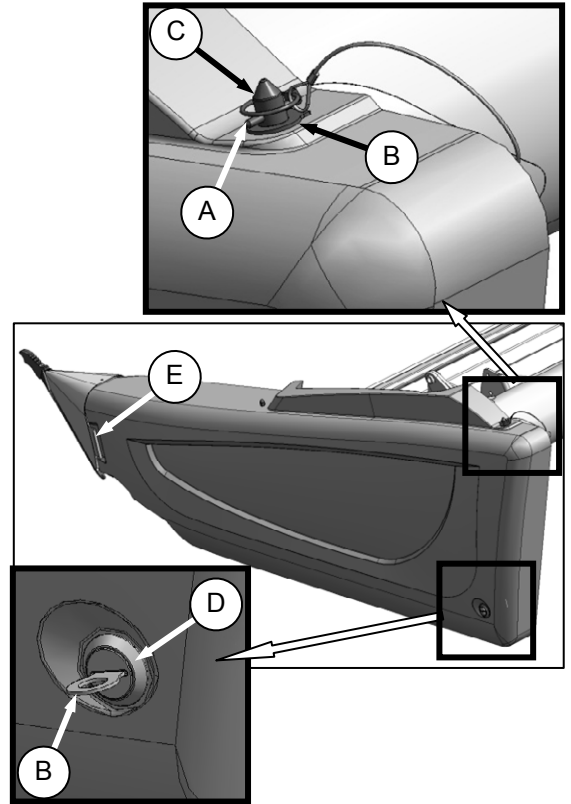

2. Remove lynch pin (A) and tool (B) from pin (C) at top rear of endshield.
3. Use tool (B) to unlock latch (D) at lower rear corner of endshield.
4. Lift shield at aft end to clear pin (C).
5. Swing shield out and away from header while maintaining forward pressure to prevent shield from slipping out of tab (E) at front of endsheet.

(continued next page)

PRE-DELIVERY CHECKS

6. Adjust gap:

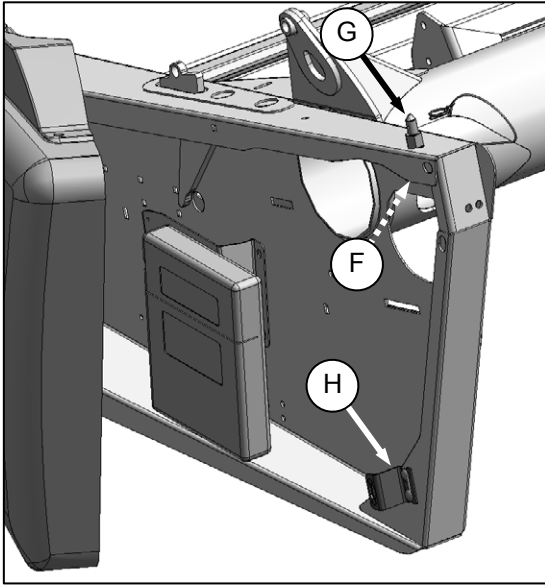

- i From inside endsheet, loosen nut (F) on pin (G).
 - ii Close endshield, and adjust position to achieve the gap 'X' between the front end of shield and header frame in accordance with chart on previous page.
7. Open endshield, and tighten nut (F).
 8. Check for a snug fit between top of shield and header frame, and full engagement of endshield on pin (G). If necessary, loosen bolts on catch (H), and adjust catch as required to re-position shield.
 9. Tighten bolts on catch (H).
 10. Close endshield.

O. OPERATOR'S MANUAL AND PARTS CATALOGS

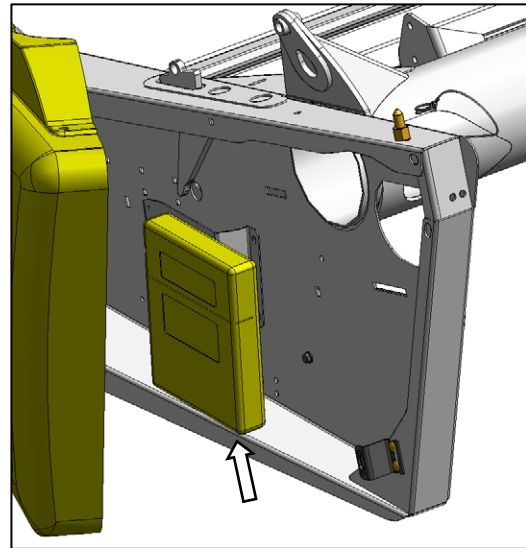

- a. Open the left endshield, and remove plastic tie on manual case.
- b. Check that case contains the following manuals:



- D65 Harvest Header Operator's Manual - Form 169593.
- D65 Harvest Header Parts Catalog - Form 169596.
- CA25 Combine Adapter Parts Catalog - Form 169598.
- D65 Harvest Header Quick Card - Form 169599.

HEADER RUN-UP

STEP 16. RUN-UP THE HEADER

- a. Start combine, raise header fully, and engage header lift cylinder locks. Shut down combine, and remove key.



WARNING

Stop combine engine, and remove key before making adjustments to machine. A child or even a pet could engage the drive.



CAUTION

Engage header lift cylinder stops before working under header.

- b. Lower poly pan under adapter, and check for shipping materials/debris that may have fallen under adapter draper:

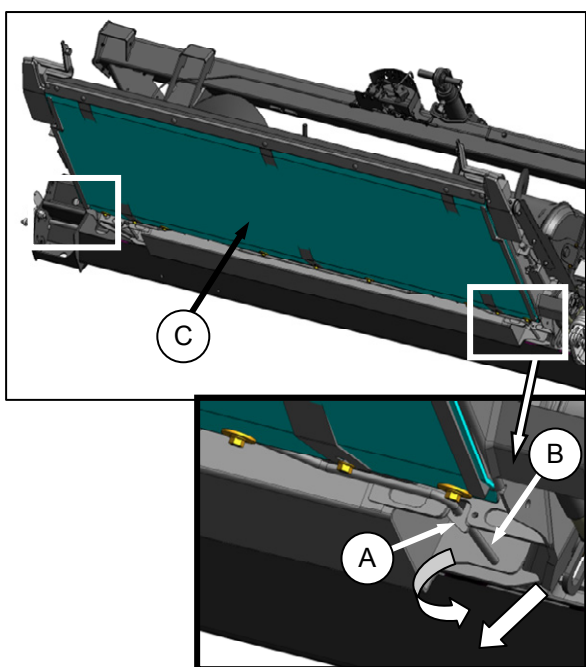

1. Rotate latches (A) to unlock handle (B).
2. Hold pan (C), and rotate handle (B) to release pan. Lower pan to expose draper.

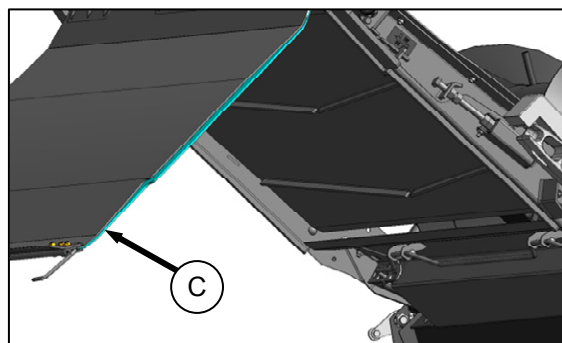

3. Check and remove debris from pan (C) and draper.

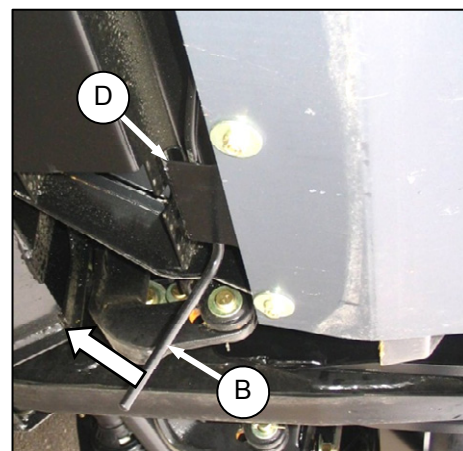

4. Raise pan, and rotate handle (B) so that rod engages clips (D) on pan.

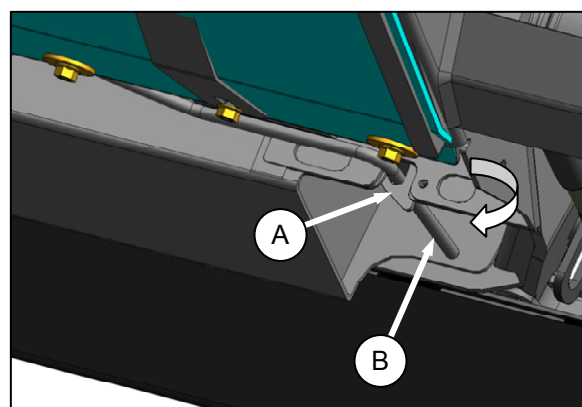

5. Push handle (B) into slot, and secure with latches (A).

(continued next page)

HEADER RUN-UP



CAUTION

Never start or move the machine until you are sure all bystanders have cleared the area.



CAUTION

Clear the area of other persons, pets etc. Keep children away from machinery. Walk around the machine to be sure no one is under, on, or close to it.



CAUTION

Before investigating an unusual sound or attempting to correct a problem, shut off engine, engage parking brake, and remove key.

- d. Ensure feeder house variable speed is set to minimum.
- e. Start combine, and run the machine slowly for 5 minutes, watching and listening FROM THE OPERATOR'S SEAT for binding or interfering parts.
- f. Run the machine at operating speed for 15 minutes. Listen for any unusual sounds or abnormal vibration.
- g. Perform run-up check as listed on **Pre-Delivery Checklist** (yellow sheet attached to this instruction) to ensure the machine is field-ready.

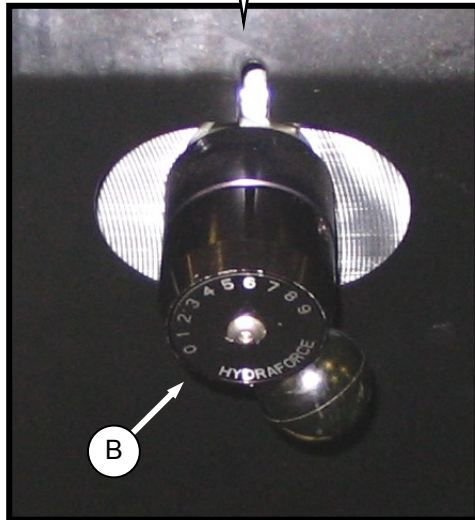
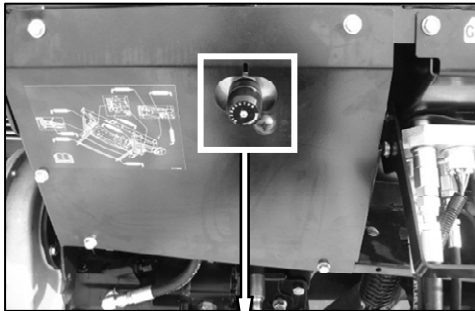

- c. Check that Flow Control (B) is factory-set to position "6" as shown above. If required, turn knob so that setting lines up with slot in panel.

NOTE

Reel and side drapers will not operate until oil flow fills the lines.

HEADER RUN-UP

STEP 17. POST RUN-UP ADJUSTMENTS

The following adjustments may be necessary after the run-up:



WARNING

Stop combine engine, and remove key before making adjustments to machine. A child or even a pet could engage the drive.

A. KNIFE

- a. Check guards for signs of heating during run-up due to insufficient clearance between guard and sickle. If heating is evident, proceed as follows:

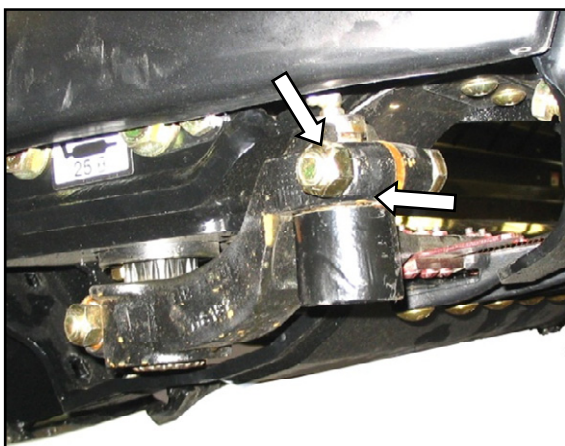

1. Check gap between knife head and pitman arm. A business card should slide easily through the gap. If not, then adjust gap by loosening bolt and tapping knife head with a hammer. Re-tighten bolt.

- b. Adjust guard alignment as follows: The guard straightening tool (MacDon #140135) is available from your MacDon Dealer.

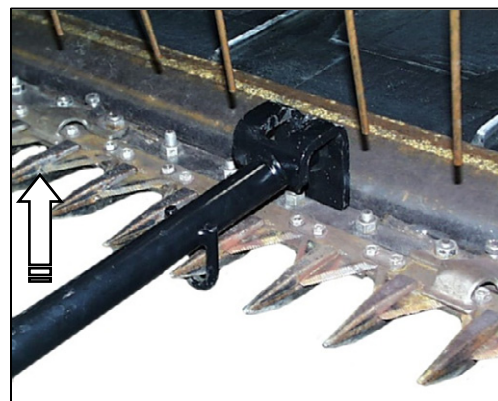

UPWARD ADJUSTMENT

1. To adjust guard tips upwards, position tool as shown, and pull up.



DOWNWARD ADJUSTMENT

2. To adjust tips downward, position tool as shown, and push down.

HEADER RUN-UP

B. KNIFE SPEED

The header knife drive is driven by the adapter mounted hydraulic pump. Knife drive speed is factory-set for a feeder house speed of 575 rpm for CNH and John Deere adapters, and 780 rpm for AGCO and Lexion adapters.

IMPORTANT

For variable speed feeder houses, this will be the **minimum** speed setting. To operate variable speed feeder house at greater than minimum speed, flow to the knife drive motor must be reduced to prevent excessive speeds which could result in premature knife failure.



WARNING

Stop combine engine, and remove key before making adjustments to machine. A child or even a pet could engage the drive.

- Stop combine engine, and remove key from ignition.
- Open LH endshield:

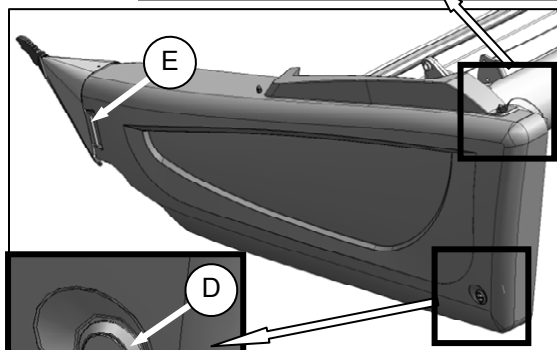
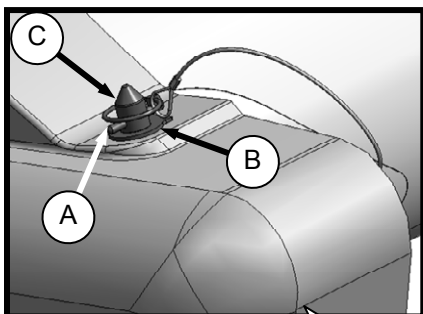

- Remove lynch pin (A), and tool (B) from pin (C) at top rear of endshield.
- Use tool (B) to unlock latch (D) at lower rear corner of endshield.

- Lift shield at aft end to clear pin (C).
- Swing shield out and away from header while maintaining forward pressure to prevent shield from slipping out of tab (E) at front of endsheet.
- Carefully disengage front of shield from tab (E), and swing front of shield away from header.



WARNING

Ensure bystanders are clear before starting.

- Start combine engine, engage header drive, and run combine at operating rpm.



- Have someone check the rpm of wobble box pulley using a hand held tachometer.
- Shut down combine, and close endshield.
- Compare actual pulley rpm with values in the following chart:

HEADER SIZE (FT)	RECOMMENDED KNIFE DRIVE SPEED RANGE (RPM)	
	SINGLE	DUAL
20	N/A	700 - 850
25	600 - 725	
30	600 - 700	600 - 750
35	550 - 650	
40	525 - 600	550 - 700
45	N/A	

- If adjustment to wobble box pulley rpm is necessary, contact your MacDon Dealer or refer to the Header Technical Manual.

NOTES

MacDon™

MacDon Industries Ltd.

680 Moray Street
Winnipeg, Manitoba
Canada R3J 3S3
t. (204) 885-5590
f. (204) 832-7749

MacDon Inc.

10708 N. Pomona Avenue
Kansas City, Missouri
United States 64153-1924
t. (816) 891-7313
f. (816) 891-7323

MacDon Australia Pty. Ltd.

A.C.N. 079 393 721
P.O. Box 243
Suite 3, 143 Main Street
Greensborough, Victoria
Australia 3088
t. 03 9432 9982
f. 03 9432 9972

LLC MacDon Russia Ltd.

123317 Moscow, Russia
10 Presnenskaya nab. Block C,
Floor 5, Office No. 534
Regus Business Centre
t. +7 495 775 6971 direct line
f. +7 495 967 7600

CUSTOMERS

www.macdon.com

DEALERS

www.macdonDealers.com

Trademarks of products are the marks of their
respective manufacturers and/or distributors.

Printed in Canada

Model D65 Harvest Header® / CA25 Combine Adapter Pre-Delivery Checklist - N.A.

Perform these checks prior to delivery to your customer. **Adjustments are normally not required as the machine is factory-assembled and adjusted.** If adjustments are required, refer to the appropriate page number in this manual. The completed Checklist should be retained either by the Operator or the Dealer.



CAUTION: Carefully follow the instructions given. Be alert for safety related messages which bring your attention to hazards and unsafe practices.

Header Serial Number: _____ Adapter Serial Number: _____

✓	ITEM	PAGE
	Check for shipping damage or missing parts. Be sure all shipping dunnage is removed.	---
	Check for loose hardware. Tighten to required torque.	5
	Check tire pressure (Transport/Stabilizer Option).	51
	Check wheel bolt torque (Transport/Stabilizer Option).	51
	Check wobble box breather position.	52
	Check wobble box lube level.	52
	Check adapter gearbox lube level.	52
	Check hydraulic reservoir lube level before and after run-up.	53
	Check sickle drive belt(s) tension.	54
	Check reel centered between header endsheets.	56
	Grease all bearings and drivelines.	64 - 68
	Check side draper tension.	57
	Check draper seal.	63
	Check header main float.	58
	Check reel tine to cutterbar clearance.	61
	Check skid shoes are evenly adjusted at a setting appropriate for first crop.	60
	Check fitment of endshields.	69
	Ensure feeder house variable speed is set to minimum.	---
RUN-UP PROCEDURE.		71
	Check hydraulic hose and wiring harness routing for clearance when raising or lowering header and reel.	---
	Check lights are functional.	48
	Check knife speed.	74
POST RUN-UP CHECK. STOP ENGINE.		73
	Check knife sections for discoloration caused by misalignment of components.	73
	Check for hydraulic leaks.	---
	Check that manual storage case contains Operator's Manual, Quick Card and Parts Catalogs.	70

Date Checked: _____

Checked by: _____