

MacDon™

PW7
Pick-Up Header
Unloading & Assembly Instructions

The Safety Alert Symbol is used to alert the reader to important safety messages in this manual. When you see this symbol, be alert to the possibility of injury. Carefully read and observe all safety messages and symbols in this manual and on your machine to avoid serious injury or death.

SAFETY ALERT SYMBOL



THIS SYMBOL MEANS

-ATTENTION!

-BECOME ALERT!

-YOUR SAFETY IS INVOLVED!

DANGER: Indicates an imminently hazardous situation that, if not avoided, will result in death or serious injury.

WARNING: Indicates a potentially hazardous situation that, if not avoided, could result in death or serious injury.

CAUTION: Indicates a potentially hazardous situation that, if not avoided, may result in minor or moderate injury.

ATTENTION: Indicates a potentially hazardous situation that, if not avoided, could result in machine damage.

*****IMPORTANT*****

Before any person uses this product he/she should take sufficient time learning all necessary precautions and procedures. Each operator should:

- Ensure all people, pets and tools are clear.
- Reads and fully understands all procedures/precautions in the Operators Manual.
- Be instructed and experienced in safe and proper use of the unit.

If additional information is required that is not covered in this manual, contact your local dealer.

INTRODUCTION

In order to ensure that the header/pickup will operate smoothly and efficiently for years to come, it is important that it be correctly set up and properly maintained. Windrow headers with pickup attachments are designed to pick up windrows of agricultural products such as wheat, soybeans, canola, barley, etc. and small seed pick ups, and are only intended for such use.

Contained in this manual are safety precautions and setup instructions and adjustments for PW7 Pickup Header, and Series IV Rake-Up and SwathMaster pickups. The units covered in this manual are compatible with John Deere 50 Series and 60 Series combines, Gleaner/Massey/Challenger Combines and Claas/Lexion combines.

The following header sizes are covered in this manual:

13 foot
15 foot

The following pickup models are covered in this manual:

PICKUP SERIES IV ATTACHMENTS

<u>Rake-Up</u>	<u>SwathMaster</u>
12' Small Seed	12' Small Seed
14'	14'
16'	16'

Note: Left and right hand are referenced from the operator's seat looking forward. The illustrations in this manual may not match your exact machine.

We welcome your suggestions, questions or comments regarding the installation, operation or maintenance of the header /pickup.

All printed publications are classified as uncontrolled documents and are subject to change without notice at the discretion of MacDon Industries Ltd.

Published: October 2010

TABLE OF CONTENTS

SECTION 1 SAFETY

1.1	General Safety Practices	4
1.2	Safety During Combine Attachment.....	4
1.3	Safety During Operation	5
	A) Extremity Lights.....	5
	B) Drive Shaft Safety.....	5
1.4	Safety During Servicing.....	6
	A) Tire Safety.....	6
	B) Holddown Safety Locks.....	6
	C) Feed House Safety Locks.....	7

SECTION 2 SETUP

2.1	Handling Units in Shipping Configuration	8
2.2	Move Wheels To Field Position.....	8
2.3	Lowering To Field Position	9
2.4	Removing Shipping Stand.....	9
2.5	Feeder House Width Completion / Conversion	10
2.6	Connecting Header/Pickup to Combine.....	11
2.7	Rotating Spring Wires Out of Shipping Position.....	18
2.8	Holddown Arm Reassembly	18
2.9	Disengaging Storage Braces / Removing Shipping Braces	19
2.10	Testing Hydraulic Holddown	
	A) Test.....	20
	B) Servicing Holddown Hydraulics	21
	C) Bleed Hydraulics.....	22
2.11	Drive Shaft Installation	23
2.12	Moving Extremity Lights Into Field Position	24

TABLE OF CONTENTS

SECTION 3 ADJUSTMENTS

3.1	Opening Header Side Panels.....	25
3.2	Removal of Pick Up Shields	25
3.3	Teeth Height Adjustment.....	26
3.4	Suspension Adjustment.....	27
3.5	Tire Pressure and Wheel Torque	27
3.6	Draper Belt Tensioning.....	28
3.7	Fiberglass Rod/Spring Wire Orientation.....	29
3.8	Pick Up Drive Belt Tension.....	30
3.9	Speed Control & Height Control.....	30
3.10	Auger Finger Adjustment.....	33
3.11	Auger Adjustment	
	A) Auger Clearance to Header Bottom.....	33
	B) Auger Forward/Rearward Adjustment Procedure.....	34
3.12	Stripper Bar Adjustment	35
3.13	Header Drive Chain Adjustment.....	35

TABLE OF CONTENTS

1.1 GENERAL SAFETY PRACTICES



All operators must:

- Be instructed in the safe and proper use of this machine and understand all safety signs and instructions in this manual.
- Carefully read all safety messages in this manual and on your machine.
- Keep all safety signs in good condition. Replace when necessary.
- Use and maintain all safety lights and devices.
- Wear necessary protective clothing when operating or servicing machinery.
- Be prepared for emergencies by keeping a first aid kit and emergency numbers easily accessible.
- Have authorized personnel repair/replace any damaged or deteriorated parts immediately to reduce the risk of personal injury.
- Find a spacious, clear, and level surface to perform any maintenance or adjustments.
- Always shut-off machinery before performing any adjustments or service.
- Never remove obstructions from running machinery.
- Never operate machinery without all shields in place.
- Never engage pickup drive with people near machine.
- Review safety instructions annually.

1.2 SAFETY DURING COMBINE ATTACHMENT

- Find a spacious, clear, and flat work area.
- Read and understand all installation procedures. Refer to applicable section in this manual for reference.
- Check for obstructions on combine, header, and in work area before starting.
- Lower header and pickup to ground or engage feeder safety locks, shut off combine, remove key and wait until all moving parts have stopped before working around header/combine.
- Take extreme care when working around hydraulic lines. Hydraulic fluid under high pressure can penetrate the skin and cause serious tissue damage. Seek immediate medical attention if skin penetration occurs.
- At all times keep body parts away from the pickup & header when moving.



1.3 SAFETY DURING OPERATION

A) Extremity Lights



Extremity Light



Extremity Lights

The header comes with a left and right hand extremity light that works in conjunction with the flashing/signal combine lights. Move the lights to field position and join the electrical connector to combine wiring harness prior to use. See Section 2.10 in this manual. For bulb replacement, see appropriate section in operator's manual.

NOTE: Disconnect the wiring harness when separating header from combine.

B) Drive Shaft Safety

- Shields are in place for your protection. Replace any worn or missing shields.
- Drive shaft shields are to rotate freely at all times (free from binding while chained). Replace worn shield bearings promptly.
- Never operate header without shields in place.
- Never make modifications to the drive shaft and shields.
- ALWAYS store the drive shaft in its storage holder. Never use safety chains to support drive shaft.
- DO NOT step on the drive shaft.
- Any servicing to the drive shaft must only be done when the header is lowered to the ground or the combine feeder house locks are engaged, the machine is shut off, the ignition key is removed and all moving parts have stopped. **Never** make adjustments to, or clean a running combine.
- Make sure drive shaft is attached properly before operation.
- Keep any loose fitting clothing, jewelry, or long hair away from moving parts, components, or retainer chains.

1.4 SAFETY DURING SERVICING

- Any servicing to machinery must only be done after the header is lowered to the ground or combine feeder house is locked, combine is shut off, the ignition key is removed and all moving parts have stopped.
- Take extreme caution around hydraulic lines. Release all pressure in the system before servicing or inspecting for leaks. Hydraulic fluid under high pressure can penetrate the skin and cause serious injury. Never use your hands to inspect lines. Seek immediate medical attention if fluid is injected into the skin.
- Familiarize yourself with proper servicing procedures in this manual.
- Wear protective clothing and use personal safety devices when required.

A) Tire Safety

- A tire that explodes could cause serious injury. Have a qualified service technician service the tires.
- When inflating tires take extreme care. An over inflated tire can explode.
- Recommended tire pressure is 8-10 psi.
- Replace rim if overly rusted or cracks are noticed.
- Stand clear from tire when inflating. Use a clip-on air chuck, and extension hose.

B) Pickup Holddown Safety Locks



WARNING: OVERHEAD OBJECT HAZARD Always activate safety locks before working under raised hold down.

- Raise hold down all the way up with hydraulic cylinder.
- Engage hold down safety locks as shown.



Safety Lock Engaged

- Complete work underneath holddown.
- Disengage safety locks as shown.



Safety Lock Disengaged



C) **Combine Feeder House Safety Locks**
(Safety Locks Will Vary According to Combine)

NOTES:



WARNING: At no time is any service procedure to be performed without the header lowered to the ground or the feeder house safety locks engaged.

Lined area for taking notes during the procedure.

- a) Raise feeder house up completely.
- b) Engage feeder house lock.



Feeder House Lock Engaged
(May not be exactly as shown)

- c) Complete work underneath header/pickup.
- d) Disengage feeder house lock



Feeder house Lock Disengaged
(May not be exactly as shown)

SECTION 2 – SET UP

2.1 HANDLING UNITS IN SHIPPING CONFIGURATION

The Header/Pickup combination units are shipped from the factory in the vertical position.

NOTE: Extra hardware shipped with units can be found attached to the square holddown tubing on pickups and/or between header floor and auger on headers.



WARNING: Be sure all persons/pets are clear when moving the pickup/header.

The proper method for lifting the pickup/header by lift truck while in the shipping configuration is shown below. It is recommended that the unit be stored in the horizontal position after being received. If being stored in the vertical position, ensure that the storage surface is flat and hard.

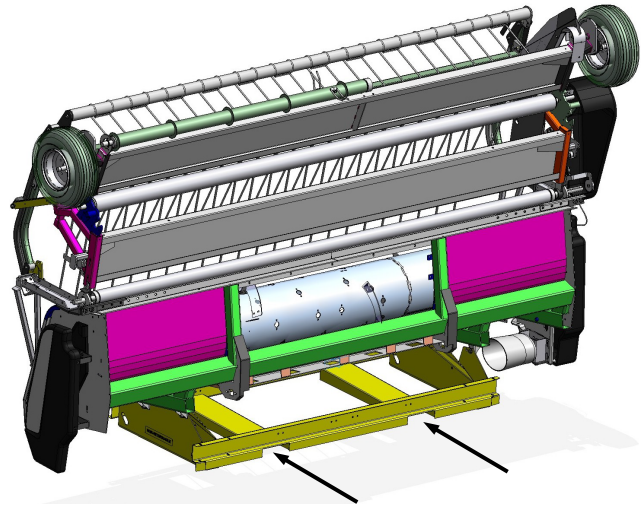

Fork Lift Pockets – 48” Fork Width

- Set the fork width to 48” and approach header/pickup from the “underside” as shown at left.

IMPORTANT: Attempting to lift header/pickup with forks not engaged in lift pockets may result in an unstable load and/or damage to shipping stands.

- Slide the forks of the lift truck into the shipping stand pockets and proceed to raise the header and pickup.
- Place the header/pickup on a level, hard, and spacious area.



**Lifting Header/Pickup
In Shipping Position**

2.2 MOVE WHEELS TO FIELD POSITION

Wheels on pickups have been shipped in a retracted position to lessen shipping height. **IMPORTANT:** To prevent damage to pick-up, rotate wheels out of shipping position prior to lowering the unit to field position. See Adjustments section – Teeth Height.

SECTION 2 – SET UP

2.3 LOWERING TO FIELD POSITION

IMPORTANT: These instructions are for lowering the unit only. Lifting should only be done using a forklift and the shipping stand.

A spreader bar is to be used to lower the header/pickup. The spreader bar should be of sufficient width to allow straps to pull directly upwards on the attachment points (spindles). Do not attach straps to, or through holddown components.

- a) Attach the straps to the spreader bar at appropriate location.
- b) Attach the straps to the pickup spindles as shown



Attaching Straps to The Unit

- d) Slowly lower the header/pickup to the ground and detach the spreader bar.
- e) Remove the shipping stand. See Removing the Shipping Stand.



WARNING: Take extreme care to prevent sudden tipping or sliding of the unit. Damage or personal injury may result.

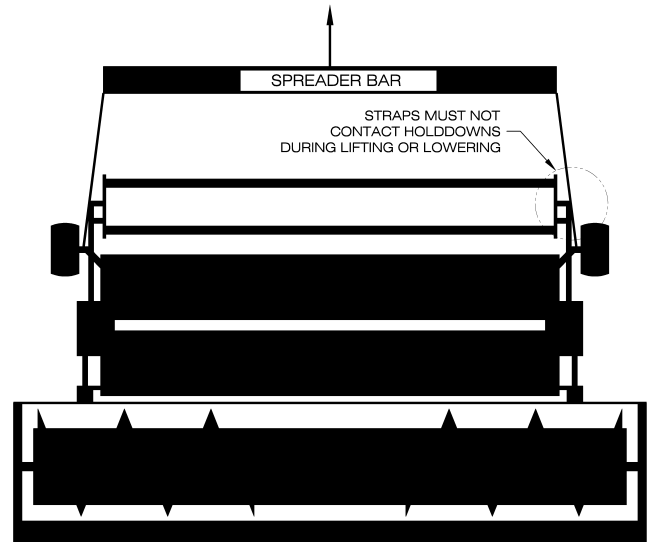

P00319

Spreader Bar Use

IMPORTANT: Damage to pickup/header resulting from lowering the unit with alternate methods will not be covered by warranty.

2.4 REMOVING THE SHIPPING STAND

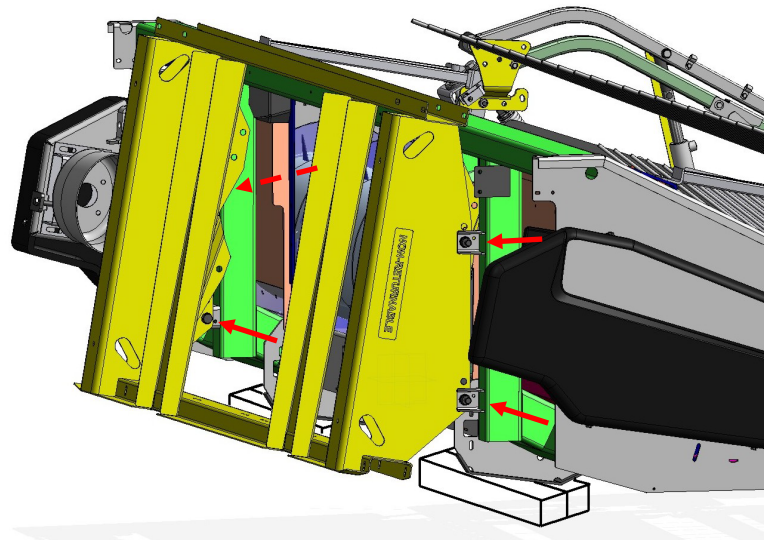

Shipping Stand

SECTION 2 – SET UP

- a) Block the header to relieve the weight on the shipping stand.
- b) Remove the 4 bolts connecting the shipping stand to the header.

CAUTION: Shipping stands are extremely heavy. Use caution when detaching shipping stands.

- c) Remove the shipping stand. Salvage one set of hardware which is required to install the drive shaft storage bracket to the left brace bracket. See Step e).
- d) Remove the blocks from under the header and lower the header to the ground.
- e) Install drive shaft storage bracket to left upper frame bracket. (Lower bracket for Lexion)

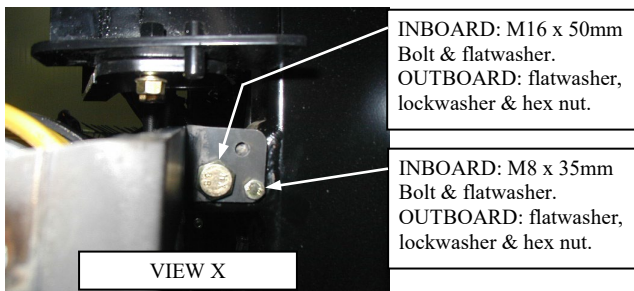
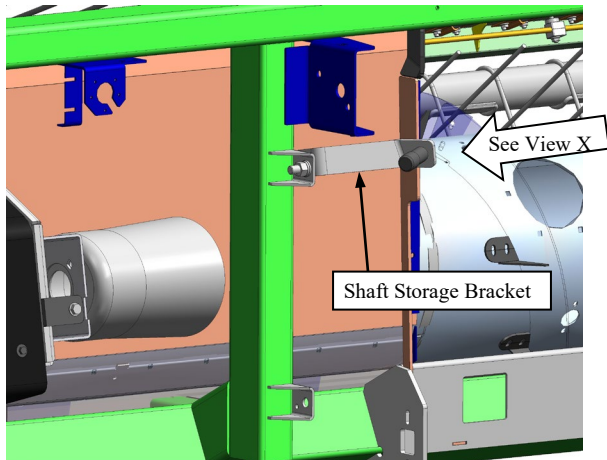

2.5 FEEDERHOUSE WIDTH COMPLETION / CONVERSION

For John Deere and Agco Combines, see the instructions supplied with the mechanical completion package to initially configure the header to suit your combine. For Lexion combines, machines are factory configured for narrow combine feeder. Before use with a Lexion combine with wide feeder house, the header must be reconfigured using the supplied parts as follows:

Lexion – Narrow to Wide:

- a) Remove the two outer auger hand hole covers to gain access to inside of auger.

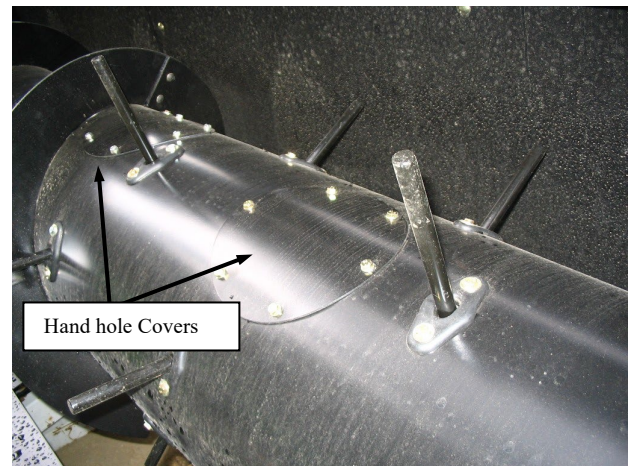

- b) Remove the auger flight extensions. These are the innermost pieces of flighting on each side of auger center.

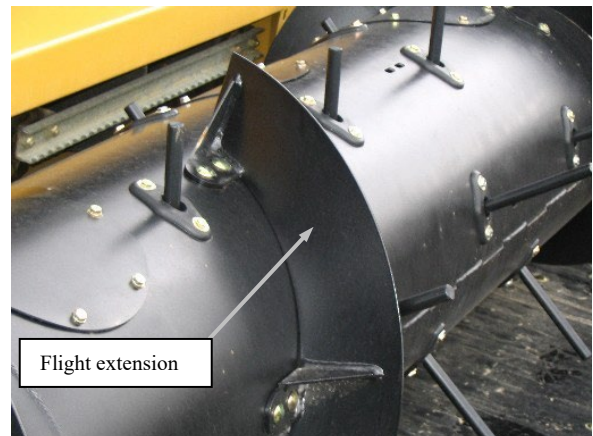

SECTION 2 – SET UP

- c) Remove finger hole covers and add two additional auger fingers and finger guides at the next two open locations at both sides of the auger (total of 4). These are shipped in the document case at back of header.
- d) Reinstall hand hole covers.
- e) Remove lower stripper bar and stripper bar extensions.
- f) Move lower stripper bars outward one hole so they are flush with combine feeder house opening and bolt to the header floor.

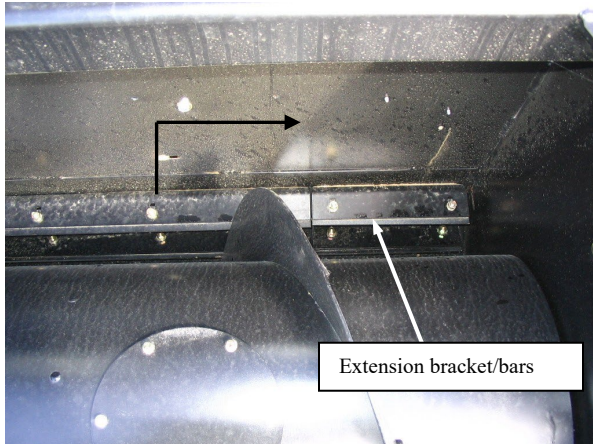

- g) Attach removed stripper bar extensions to the outside of the back wall of header for storage.



Stripper Bar Storage

- h) Adjust stripper bars. See section 3.12 in this manual.
- i) Save all removed components for conversion back to narrow opening at a later date if necessary. In this case, the process described above must be reversed.

2.6 CONNECTING HEADER/PICKUP TO COMBINE

NOTE: The operator of the combine should be well trained in the use of combine controls. Improper use of the combine could result in damage to property or serious injury or death.

- a) Check to see that all header and feeder house locking devices are open and ready for engagement.
- b) On combines equipped with feeder house adjustment, the feeder house face front to back adjustment must be positioned so that the header floor is parallel to the ground when header is in operating position.
- c) Lower the combine feeder house so that the feeder house saddle will just pass under the upper beam of the header
- d) Enter the header opening and lift the header off the ground. The feeder house saddle and header beam should now be firmly engaged.
- e) Raise the feeder house completely.
- f) **TURN OFF COMBINE ENGINE, REMOVE THE KEY FROM THE IGNITION, AND ENGAGE THE FEEDER HOUSE SAFETY LOCK.**

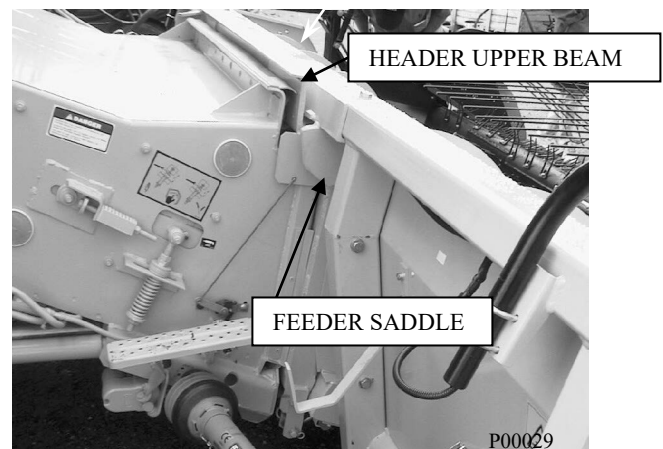

Positioning on Combine

(May not be exactly as shown)

SECTION 2 – SET UP

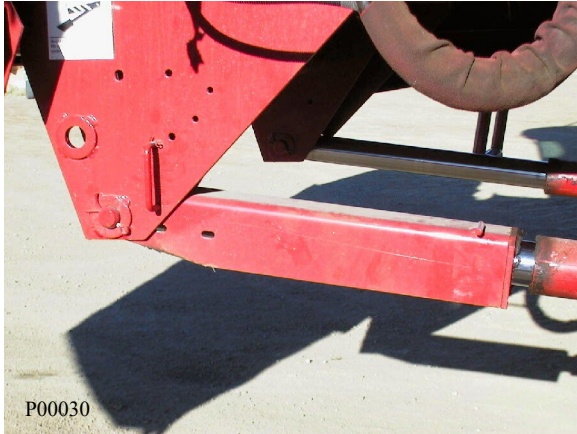

Engaged Feeder House Lock
(May not be exactly as shown)

- g) Engage the header locking mechanisms wiring and hydraulics. Refer to the “Completing Hook Up to Your Combine” section for combine specific instructions.
- h) Attach auger drive shaft. See “Drive Shaft Installation” in this manual.
- i) Disengage the feeder house locks and secure in the storage position.



Disengaged Feeder House Lock
(May not be exactly as shown)

Completing Hook Up To Your Combine

Each combine manufacturer has a different design for lower locking mechanism on the header. The locking mechanism is an important step in protecting your header/pickup from damage.

On all models the feeder house must be properly installed onto the header before the locks could be activated.

ATTENTION: Do not operate or move header without engaging the lower locking mechanism. Failure to do so may cause damage to your equipment.

2.6.1 JOHN DEERE

50 Series:

- a) Engage feeder house locking pin into the slot of the header, both sides.
- b) Loosen the nuts of the header locking plates.
- c) Position the plate so that the lower corner of the plate rests against the pin.
- d) Check that pin moves freely in and out.
- e) Tighten the header adjustment plate nuts.

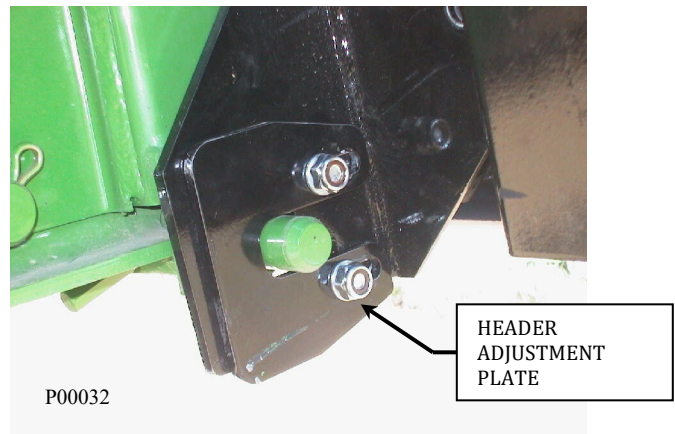

John Deere Locked Position



50 Series Open Position

SECTION 2 – SET UP

- f) Complete the assembly of hydraulic and electrical components as follows:
- Install L/H sub-assembly as shown, using two M10 x 30 bolts, flatwashers (under bolt heads) and lock nuts.
 - Attach hoses from R/H sub-assembly to hydraulic lines at L/H side, matching yellow cable ties as shown. Attach hose from L/H sub-assembly to hold down line.

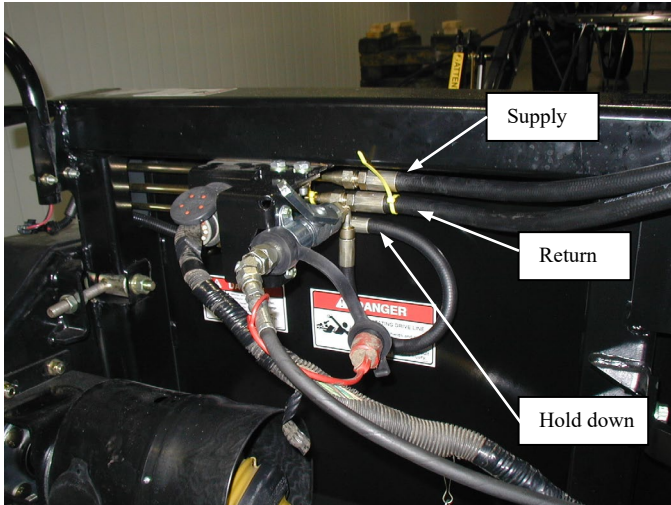

L/H Hydraulic / Electrical – 50 Series

- Route hose across header to R/H side and secure with four clamp assemblies. (Clamps not as shown in photo). Use M8 x 55 bolts, lock washer, flatwasher, cover plate and double-hose clamp as shown.

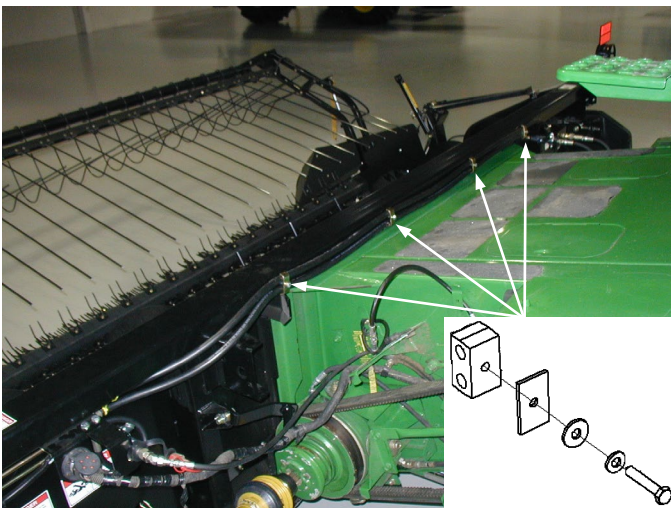

Route Hoses Across Opening

- Install R/H sub-assembly as shown, using two M10 x 30 bolts, flatwashers (under bolt heads) and lock nuts.



R/H Hydraulics – 50 Series

60 Series:

60 Series combines come equipped with a multi function system, which connects the hydraulics, electrical and mechanical locks.

- a) At first use, attach lever to header at left side of delivery opening, using 3/8 x 1 inch shoulder bolts, top and bottom. Install rubber pad as shown.

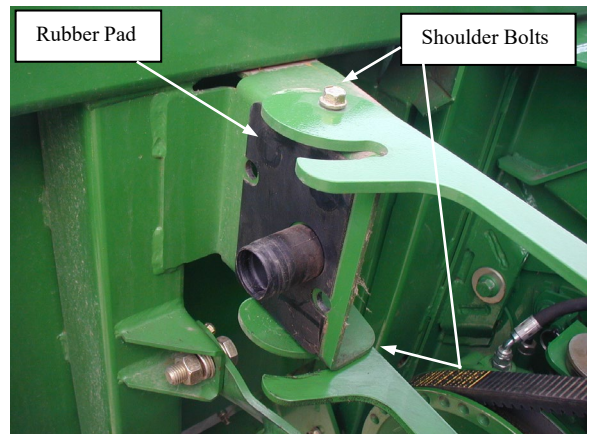

Install Handle & Rubber Pad – 60 Series

- b) At first use, attach hoses from multi-coupler assembly to hydraulic lines at L/H side, matching yellow cable ties as shown. See photo next page.

SECTION 2 – SET UP

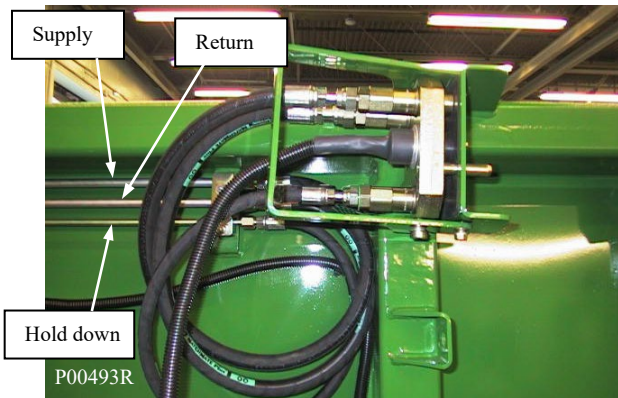
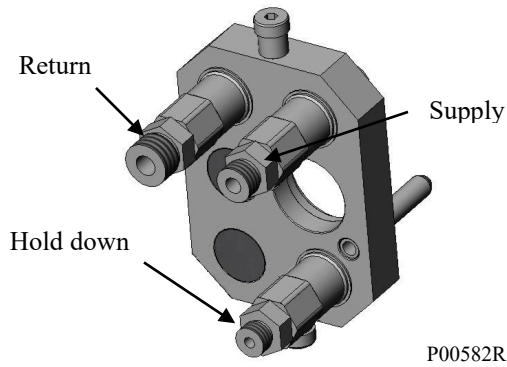

Hydraulic Coupler in Storage Bracket

- c) Remove the hydraulic multi coupler from the storage bracket.
- d) Install the multi coupler onto the feederhouse coupler.
- e) Lower the lever into the engaged or locking position. This will automatically engage the header / feederhouse locks, wiring and hydraulics.

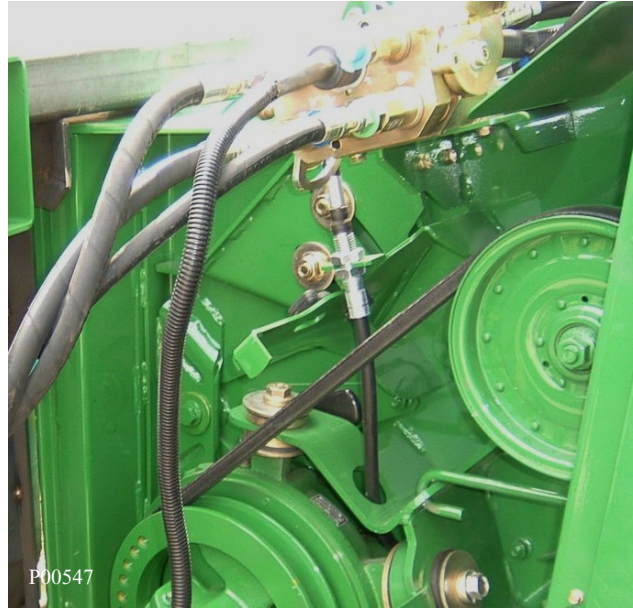

Hydraulic Coupler in Field/Locked Position

To Adjust Plates:

- a) Loosen the nuts of the header locking plates.
- b) Position the plate so that the lower corner of the plate rests against the pin.
- c) Check that pin moves freely in and out.
- d) Tighten the header adjustment plate nuts.



Lower Locking Pin

SECTION 2 – SET UP

2.6.2 CLAAS / LEXION

- a) Check that locking pins are in outward position and secured with clevis pin in hole #2.

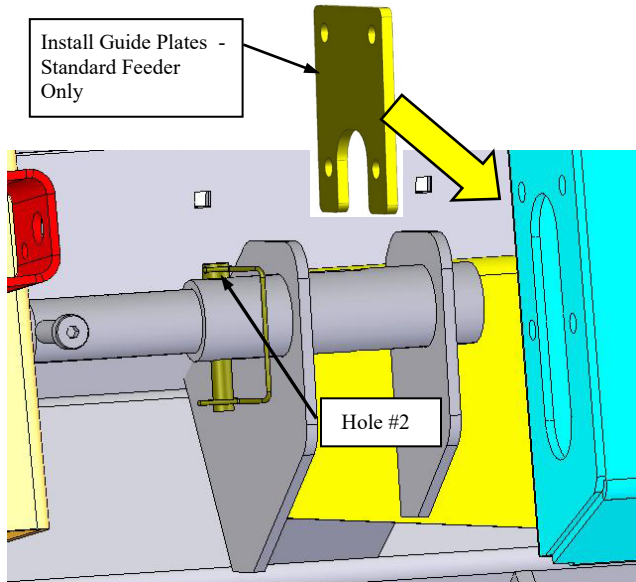

- b) Guide plates are stored in the document holder on the back side of the header. Install guide plates at lower slots on **standard** feeder house only. Guide plates are not required with HP (Header Pitch) feeder house.
- c) Disengage the feeder house locks and secure in the storage position. Lower feeder house so hooks are below mounting bracket.
- d) Move combine into header opening and align cylinders or feeder hooks with mounting brackets on header.

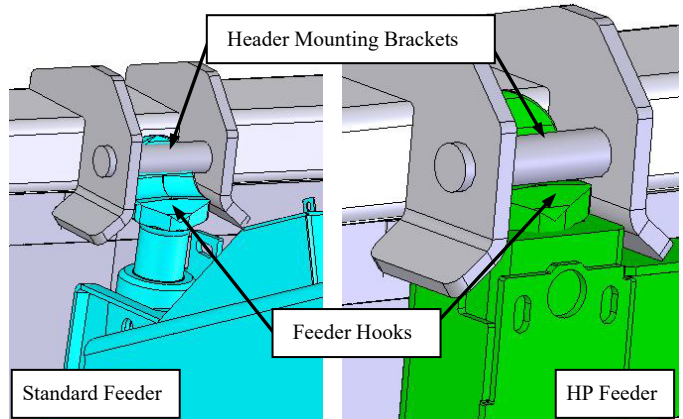

- e) Raise feeder house completely and engage feeder house lock.
- f) Insert lock pins in place using hole #1. Pin must be at the top of the slot as shown.

Note: On combines equipped with feeder house fore-aft tilt, the feeder house face must be positioned so that the header floor is parallel to the ground when header is in operating position.

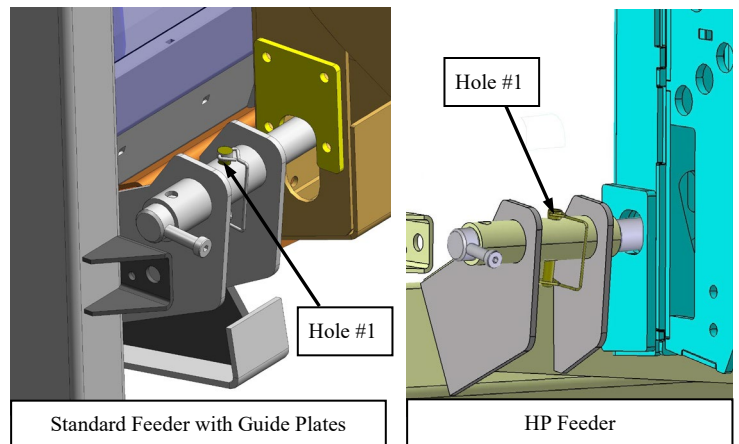

Combines with auto-contour:

Extend cylinder to approximately the middle position. Install guide plates as above to lock the auto contour. Guide plates are stored in the document holder on the back side of the header.

ATTENTION: Not installing locking guide plates on combines with auto-contour may lead to pickup disconnecting from combine, especially when auto-contour is tilted to one side. Severe machine damage can result.

SECTION 2 – SET UP

- g) Disengage pickup storage braces. See Storage Brace Disengagement –next section in this manual.

ATTENTION: Never lower header to the ground while the locking pins are in place and storage braces are engaged. This will cause severe damage to your machine

ATTENTION: Locking pins must be correctly engaged into feeder slots. Operating the unit with locking pins disengaged or improperly engaged can severely damage the unit.

- h) At first use, connect hoses to header hydraulic lines as shown.
- i) Remove the hydraulic/electrical multi coupler cover from the storage bracket.
- j) Install the multi coupler from the feeder house onto the header multi coupler.
- k) This will automatically engage the wiring and hydraulics.

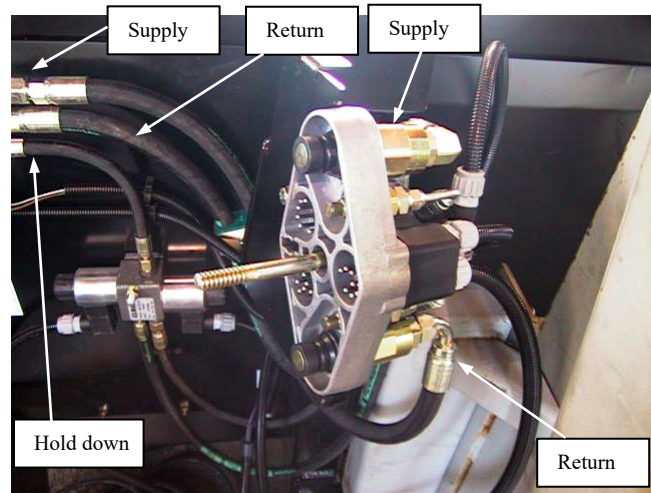

Header Multi Coupler



Feeder house Multi Coupler in Storage

SECTION 2 – SET UP

2.6.3 AGCO

- a) Engage lower locking mechanism as follows: Insert concave door tool (E) in latch socket (F) and rotate latch clockwise to lock hooks (G) into the adapter frame (both sides). **MAKE CERTAIN** that the latch is rotated over-center to securely lock the hooks. If it does not latch, check to determine if the lower pins (H) are seated in the adapter back. If not, place a block under the left end of the adapter and lower the adapter to reseat the pins. Re-latch the hooks.

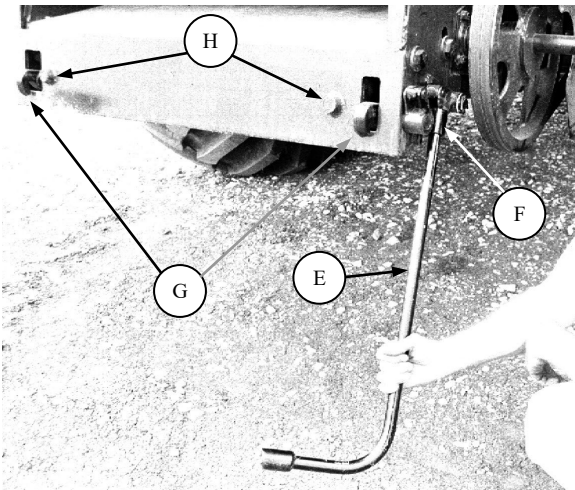

LOCK HOOKS INTO ADAPTER FRAME
BOTH SIDES - Agco

- b) Attach hydraulics and electrical - Single Point Connection:
At first use, connect hoses to header hydraulic lines as shown. Match yellow cable ties on the return hose and steel line. Clean all hydraulic hoses and couplings before connecting to prevent contamination of hydraulic system. Align the single point header connector (A) with the single point connector on the combine (B) and lock by moving latch (C) over-center.

NOTE: To install a header with single point connector on a combine without a single point connector, an adapter is required. See your combine dealer.

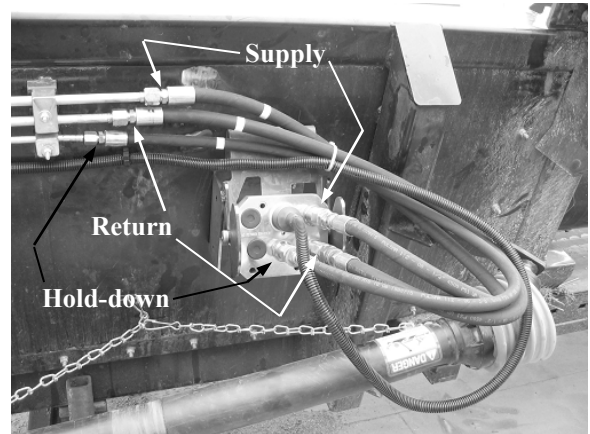

Agco Single Point Connector – Header Side

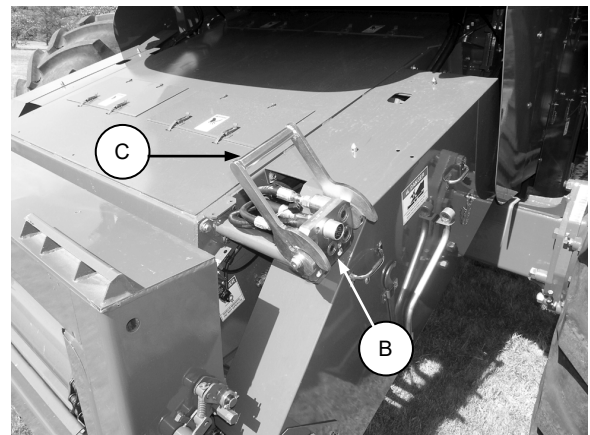

Agco Single Point Connector – Combine Side

SECTION 2 – SET UP

2.7 ROTATING SPRING WIRES OUT OF SHIPPING POSITION

NOTE: The spring wire tube is set in shipping position when shipped from the factory. Before operating the pickup, rotate the spring wire tube to field position.

- Remove the 1/2" clevis pin and hitch pin.
- Align each spring wire to its corresponding tab so that spring wire can rotate freely.
- Rotate the spring wire tube handle just over a full turn, so that the tab begins to engage the spring wire (see following diagrams).
- Secure with the 1/2" clevis pin and hitch pin.

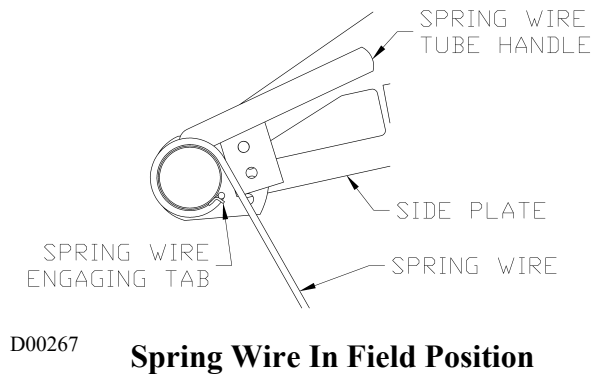
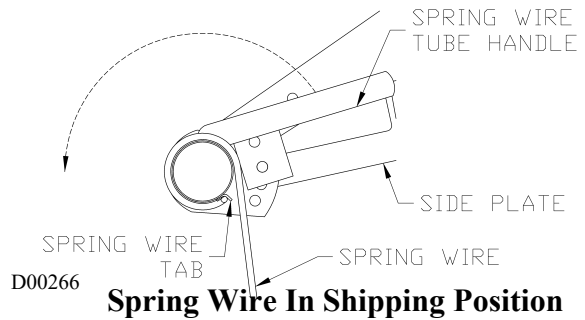

2.8 HOLDDOWN ARM REASSEMBLY

REFER TO ILLUSTRATION NEXT PAGE

NOTE: Do not remove yellow shipping braces (D) until unit is laid down and arms are moved to working position. See next section for instruction on removing shipping braces.

To meet trucking height restrictions, additional disassembly was required at the factory to hold-down arms.

- Support front of hold-down assembly at (E).
- Remove hardware (A) securing back end of hold-down arms to yellow shipping bracket (B). Attach arms to pickup frame at (C), re-using hardware (A). (Orientation of hardware is not critical.)
- Remove yellow shipping brackets (B) from unit.
- Repeat at other side.

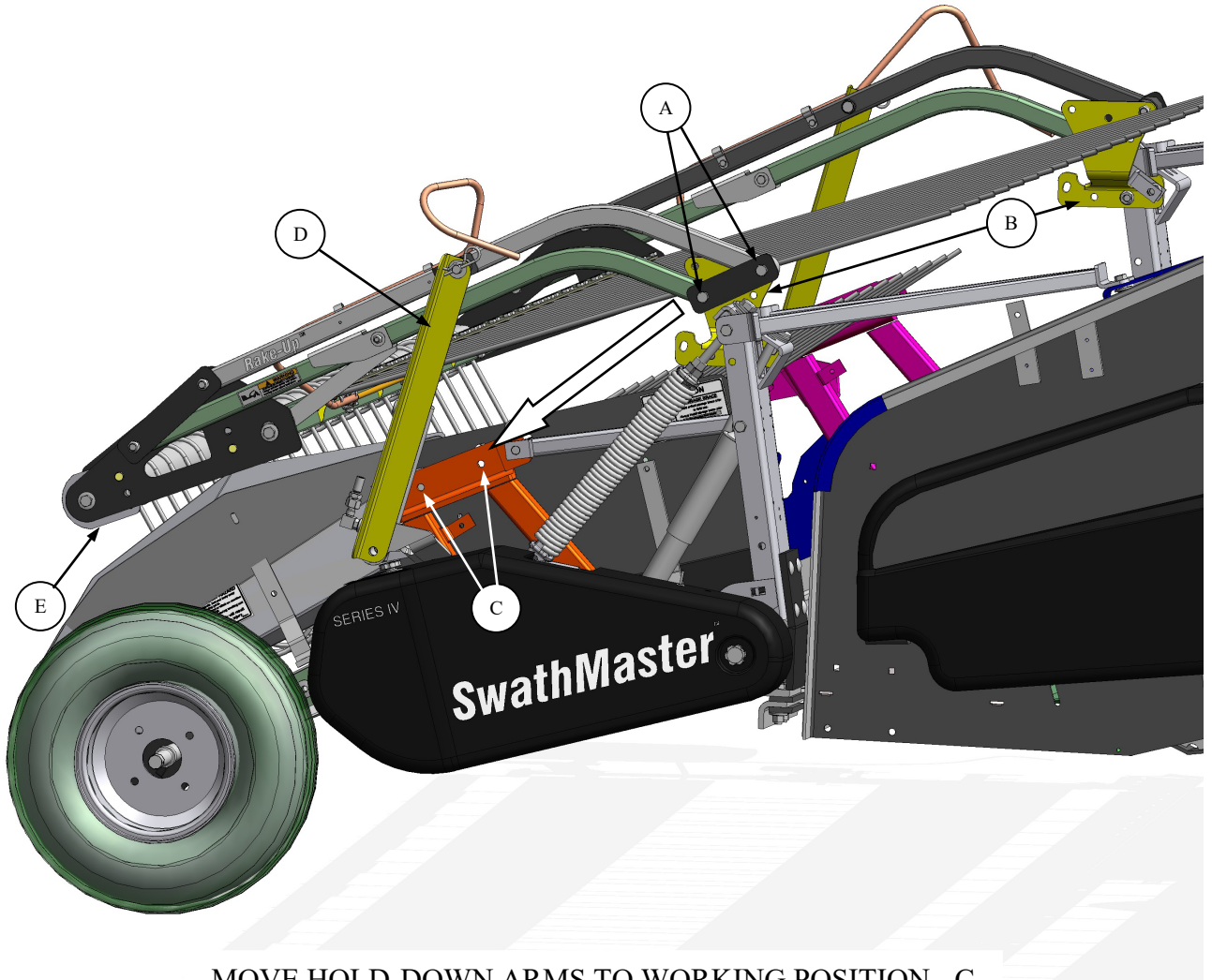

MOVE HOLD-DOWN ARMS TO WORKING POSITION - C

**2.9 DISENGAGING STORAGE BRACES
/ REMOVING SHIPPING BRACES**

NOTE: Before disengaging storage braces, raise the header so wheels are just off the ground.

Pickups are delivered with the storage and cylinder braces engaged. Storage and cylinder braces are located on each side of the pickup. Before the pickup can be used, storage braces and cylinder braces **must** be disengaged or machine will be damaged.



SECTION 2 – SET UP

DISENGAGING STORAGE BRACES

- a) Remove clevis pin.
- b) Rotate storage brace upward into the stiff-arm clevis. **NOTE:** Rotate clevis from its collapsed shipping position to the position shown below. Tighten clevis mounting hardware to secure the position.

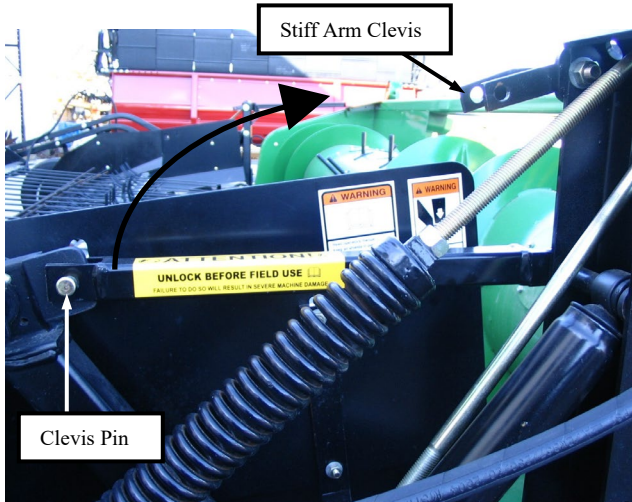

- c) Place clevis pin in stiff-arm clevis and replace clip pin to secure brace upwards.

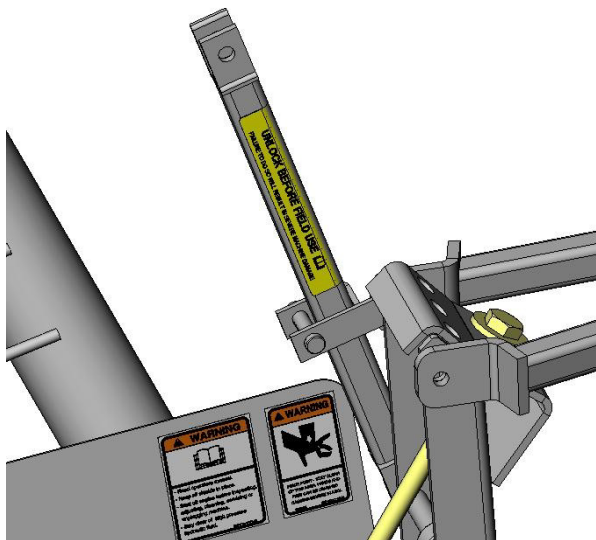

Storage Brace Disengaged

REMOVE CYLINDER SHIPPING BRACES

NOTE: Do not remove yellow shipping braces (D) until unit is laid down and arms are moved to working position.

- a) Support front of hold down assembly (E) and remove the top lynch pins, washers and cylinder pins securing braces (D), both sides.
- b) Rotate braces down. Remove wire securing cylinder rod to brace and raise cylinders until aligned with top pin position and reinstall top cylinder pins, washers and lynch pins.
- c) Remove bottom lynch pins and washers. Remove braces and reinstall the washers and lynch pins, both sides.

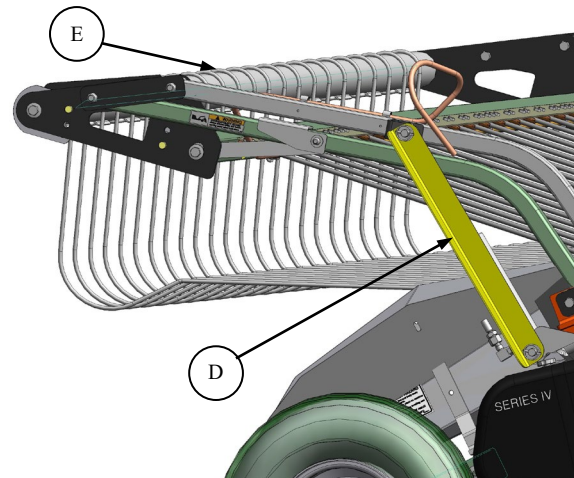

Remove Cylinder Shipping Braces

2.10 TEST HYDRAULIC HOLDDOWN

NOTE: All testing performed with the header/pickup in operating position (wheels are on the ground and the distance from the ground to the center of the rear roller is about 14" (356mm)). This is the standard operating height to be described later in manual.

A) TEST

- a) The holddown is controlled by the reel lift control located in the combine cab. Activate the control to lift the holddown. The cylinders should begin lifting simultaneously.

SECTION 2 – SET UP

- b) Lift the holddown completely to the top. Continue to force the cylinders up for one to two seconds to ensure the cylinders re-phase. Both cylinders should be fully extended.
- c) Lower the holddown. The cylinders should lower at the same time and at the same rate. It should take from 12 to 18 seconds for the holddown to lower from the highest point.
- d) Completely lower the holddown. The cylinders should stop at the same time. It is acceptable for the slave cylinder to remain from 0 to 1/2" (13mm) extended when the master cylinder is fully retracted.

Should the hydraulics not perform as above, complete the following procedures:

B) Servicing Holddown Hydraulics

If your holddown is operating unevenly, follow the instructions in this section to step by step troubleshoot its operation.

Prior to beginning to troubleshoot the hydraulics, additional orifice should be obtained from your dealer. The following procedures indicate adjustments to perform as needed.

Problem 1: Slave Cylinder Remains Extended More Than 1/2 inches (13mm) When the Holddown is Fully Lowered.

Probable Solution: Bleed Hydraulics

- a) Bleed the hydraulics as described in the bleed procedure. (Section C)
- b) Retry the holddown.

- c) Check for improvement.
- d) Repeat two or three times as necessary.

Problem 2: Master Cylinder Lags Behind Slave Cylinder on Descent and Jumps Ahead of Slave When Lifting.

Probable Solution(s): Bleed Hydraulics.
Install Larger Orifice in Bottom of Master Cylinder.

Service Parts: 1/16 inch Orifice (Part # 180625)
1/32 inch Orifice (Part # 180102)

- a) Bleed the hydraulics as described in the Bleeding of Hydraulics.
- b) Retry the holddown.
- c) Check for improvement.
- d) Repeat two times if required.

If this does not work, then replacing the orifice in the master cylinder may fix the problem.

- a) Loosen and remove the hose at the bottom of the master cylinder. Keep rags handy to clean up leaking hydraulic oil.
- b) Loosen and remove the elbow from the bottom of the master cylinder.
- c) Using a large bladed flat screwdriver, loosen and remove the orifice from inside the bottom port of the cylinder.
- d) Install the 1/16-inch orifice in the bottom port. Do not over tighten.
- e) Replace the elbow and the hose.

SECTION 2 – SET UP

- f) Bleed the hydraulics as described in the Bleeding the Hydraulics.
- g) Repeat two or three times as needed.
- h) Check the overall operation of the holddown. Installing the 1/16-inch diameter hole orifice will likely prevent the master cylinder from lagging.

C) Bleeding the Hydraulics

In order for the hydraulics to perform properly, all or most of the air must be removed from the system. The following procedure provides the easiest method of bleeding the hydraulics. The hydraulics should be bled after initial installation, if the unit has sat for a significant period of time, and if adjustments are needed to the hydraulics.



CAUTION: High-pressure hydraulic oil can cause serious injuries such as burns, cuts, and tissue damage! Always take precautions when working with hydraulic oil. Wear safety goggles, gloves and thick clothing. Seek immediate medical attention if cut or burnt.

- a) The hold down is controlled using the reel lift control located in the combine cab. Fully raise the hold down.
- b) Engage the hold down safety locks. Ensure that the lock is fully rotated over center so that it will not slip forward.
- c) Lower the hold down so that it comes to rest on the safety locks. (This serves to relieve the hydraulic pressure in the lines).

- d) Hold the plastic pail so the lip of the pail is underneath the bleed plug and so that a stream of oil shooting out of the plug will go into the pail.
- e) Loosen the small bleed screw on the end of the bleed plug with a 1/4-inch wrench.
- f) Have someone activate the hydraulics. The holddown may lift slightly and a stream of oil will come from the bleed screw.
- g) Run oil from the bleed screw until it is a steady clear stream. Have the operator stop activating the hydraulics and tighten the 1/4inch bleed screw.
- h) Fully raise the holddown again.
- i) Disengage the safety locks.
- j) Lower the holddown.



Bleeding of Hydraulics

SECTION 2 – SET UP

2.11 DRIVE SHAFT INSTALLATION

The drive shaft is to be installed after the header/pickup is attached to combine.



WARNING: DO NOT begin to perform any service procedure until header is lowered to the ground or feed house locks are engaged, combine is shut off, the key is removed and all moving parts have stopped.

- a) Engage the feeder house lock or lower the header completely down.
- b) Shut off engine and remove the key from the ignition.
- c) Take the clutch end of the drive shaft, pull back the locking plate and slide it onto the drive shaft of the header
- d) Release the locking plate and continue sliding it on to the header shaft until it clicks into place. Pull back to ensure that drive shaft is locked into place.



Drive Shaft to Header Installation

- e) Attach both drive shield chains together.
- f) Attach the single chain clip to the back of the header.



Chain Clip Attachment

- g) Take the combine end of the drive, pull on the quick disconnect slide collar and slide it onto the shaft of the combine.
- h) Release the collar and continue sliding it onto the combine shaft until the yoke locks into place. Pull back to ensure that drive shaft is locked



Drive Shaft to Header Installation

- i) If placing drive shaft in storage mode, lock into holder by pulling back locking collar and sliding onto bracket stub shaft. See photos next page. See page 10 for details on installation of storage bracket onto header.

SECTION 2 – SET UP

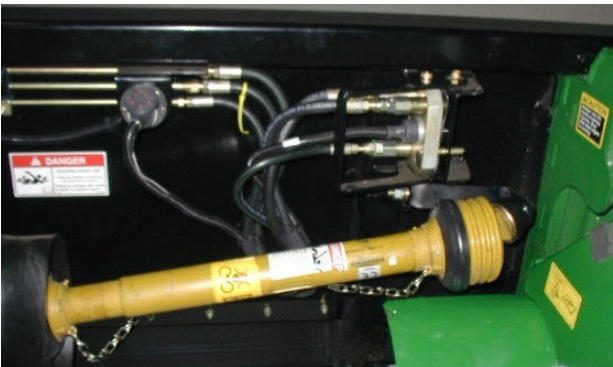
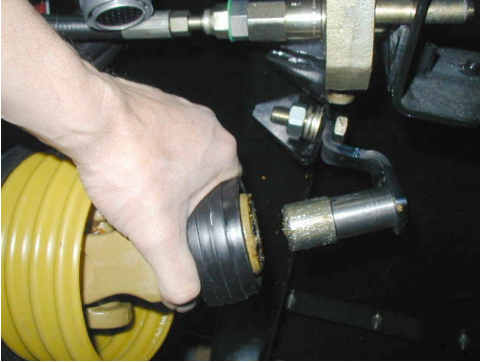

Drive Shaft Storage Bracket

2.12 MOVING EXTREMITY LIGHTS INTO FIELD POSITION

The extremity lights are shipped from the factory in a shipping position. The following procedure will provide instructions on changing them to field position.

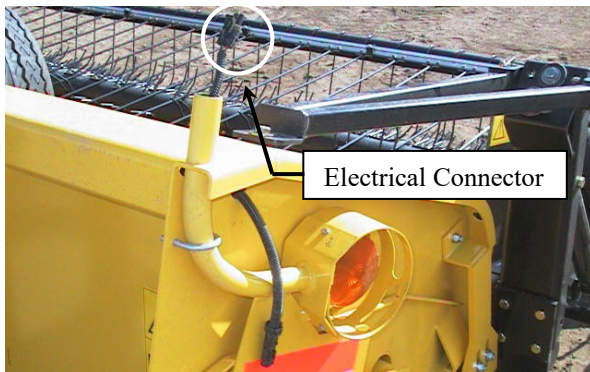

Light in Shipping Position

- Loosen the M8 nuts on the U-bolts that secure the light bracket to the header.

- Remove the extremity light and place in field position.

NOTE: When tightening the U-bolt nuts be sure not to over torque them. Over torque will deform the light bracket on the header.

- Tighten the M8 nuts previously loosened.

- Plug in the electrical connector.

NOTE When plugging in the harness terminals, make sure they are pushed in far enough that they lock together. This will ensure a watertight seal.



Harness Terminal



Extremity Light

SECTION 3 – ADJUSTMENTS

All products come with initial adjustments setting from factory. The following section is supplied for your reference and may be used to verify any settings or adjustments before delivery.

3.1 OPENING HEADER SIDE PANELS

To remove left panel, unscrew bolts and lift up on panel.



Left Hand Shield

To remove right panel, unscrew bolts and pull away from header.



Right Hand Shield

NOTE: It is not necessary to remove panels to perform adjustments on units.

3.2 REMOVING PICKUP SHIELDS

SWATHMASTER

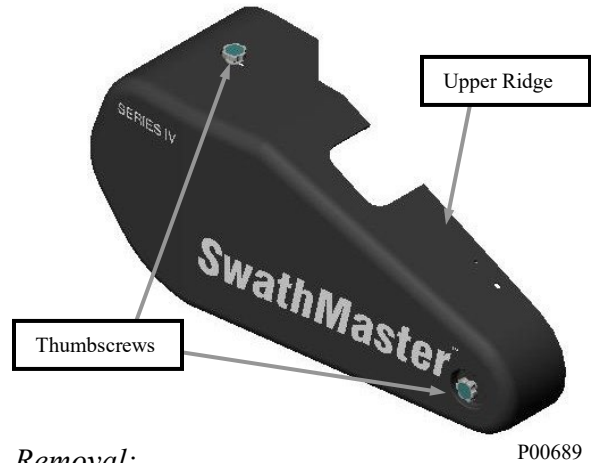

Removal:

- Unscrew the upper and side thumbscrews.
- Grabbing hold of the upper ridge, pull off the Shield.

Installation:

- Position the shield onto the brackets and slide back and forth until circular indentation falls into the rear guide.

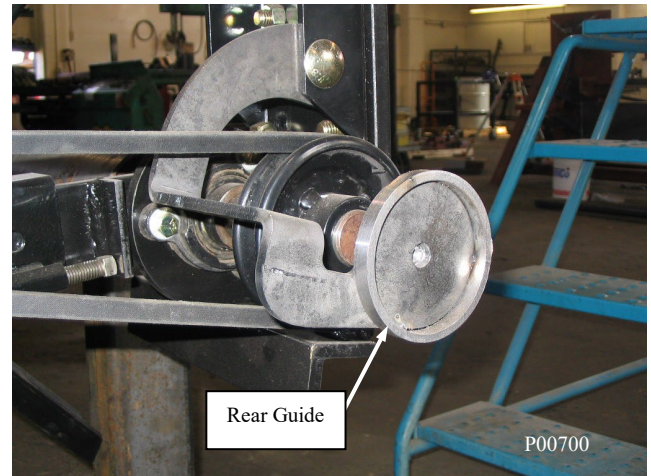

- Tighten the thumbscrews.

SECTION 3 – ADJUSTMENTS

RAKE-UP

Remove four 5/16” bolts and pertaining hardware.



Rake-Up Drive Shield Removal

3.3 TEETH HEIGHT ADJUSTMENT

Wheels on pickup units have been shipped in a retracted position to lessen shipping height. Loosen clamp bolt and rotate to field position. For both SwathMaster and Rake-Up units, the recommended initial setting provides a clearance of 1/2 inch (12mm) between the teeth and the ground. This clearance is achieved when the 6th cog from the bottom on the pick up frame wheel plate lines up with the adjustment cog on the wheel spindle plate. See following.

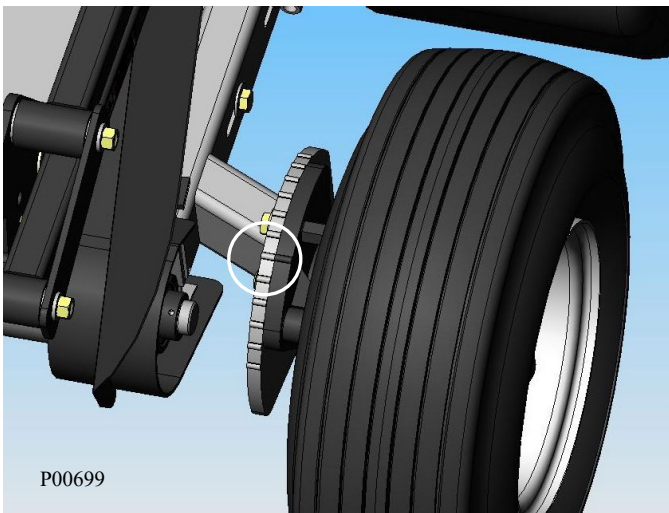

Recommended Initial Setting

To Adjust Teeth Height:

1. Check to see tire pressure is in desired range. (8-10 psi.)
2. Position the pickup so the rear roller is 14” above ground (350mm). Check tooth height at this time. If an alternative height is desired, proceed with steps 3 to 8.
3. Raise the pick-up until the center of the rear roller is approximately 20” above the ground.
4. Using a 3/4” wrench, loosen the clamping/adjustment bolt on one side of the pickup.
5. Using two 3/4” wrenches, move the adjustment nut to the desired clearance.
6. Tighten the clamping bolt to lock into place.



Wheel Adjustment

7. Repeat steps 4 to 6 for the other side. Match the LH and RH wheel height using the cogs on the wheel plates.
8. Adjust suspension.

NOTE: When wheel height/teeth height is changed, suspension should be adjusted as well.

SECTION 3 – ADJUSTMENTS

3.4 SUSPENSION ADJUSTMENT

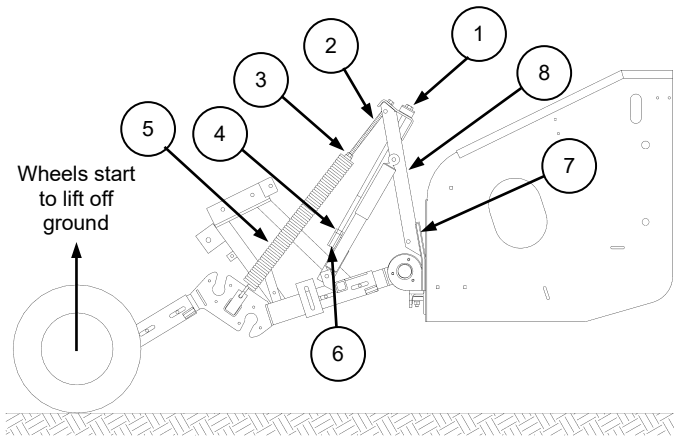

Suspension System Assembly and Parts List (Illustration May Differ)

1. Lifter Adjustment Bolt (w/rubber stoppers)
2. Spring Bolt
3. Spring Bolt Locking Nut
4. Lifter Adjustment Bolt Locking Nut
5. Spring
6. Lifter Bracket
7. Mounting Bracket Plate
8. Channel Upright

- a) Adjust tooth/wheel height. See previous page.
- b) Lower header until wheels just touch the ground. [Rear roller approximately 20 inches (508 mm) above the ground.]
- c) Tighten the spring bolt (2) evenly on both sides until the wheels begin to lift off the ground. Turn the spring bolt clockwise to lift the wheels and counter clockwise to lower the wheels.

NOTE: The friction in the gas shock absorbers must be compensated for by lifting the wheels during tightening and allowing them to fall to their normal resting position. The height of the wheels should be checked in this manner after every 1/2 inch (12mm) of spring adjustment.

- d) Tighten the spring bolt-locking nut (3) against the spring casting to prevent loosening.
- e) Raise header so wheels are approximately 6 inches (150 mm) off the ground.
- f) Lower storage brace into engaged (float lockout) position and insert clevis pin (see Section 2.9). If pin does not go in, adjust lifter adjustment bolt (1) so clevis pin can be easily installed and removed.
- g) Jam the lifter adjustment bolt-locking nut (4) against the lifter bracket (6).

Note: If ground speed is above 7 mph (11 km/h) it may be necessary to back off the float to prevent the header from bouncing excessively.

Note: During field operation, the rear roller shaft should be at 14 inches (350 mm) above the ground.

3.5 TIRE PRESSURE AND WHEEL TORQUE



WARNING: An over inflated tire could explode and cause serious injury or death. Read tire safety section before continuing.

- a) Tire inflation: 8 to 10 psi (55-69kPa)
- b) Wheel bolt torque: 60 lb-ft

SECTION 3 – ADJUSTMENTS

3.6 DRAPER BELT TENSIONING

The pickup draper belts are installed and set at the factory, however the draper belt tension should be checked before operating.

A) Adjustment:

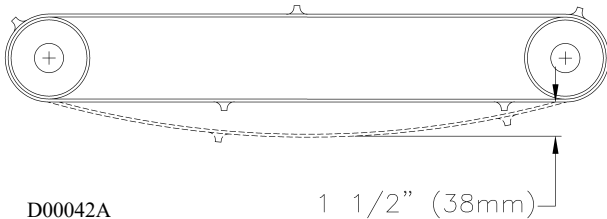

Draper Belt Adjustment

- Loosen 1/2-inch carrier bracket bolts shown in Pickup Belt Tensioner and Carrier Bracket Bolts.
- The belts are tensioned using 1/2 inch set screw.

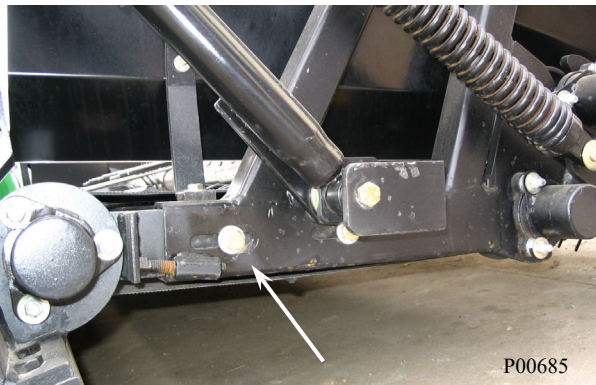

Carrier Bracket Bolts

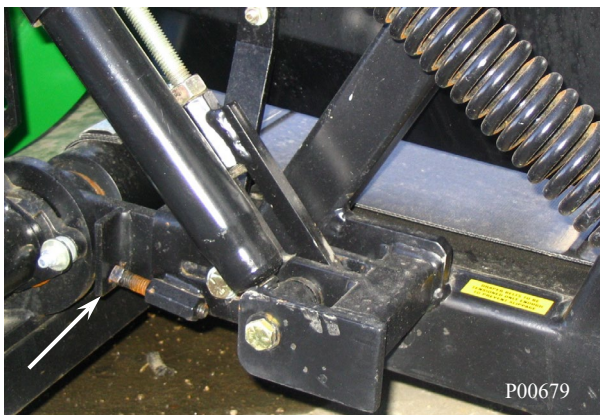

Pickup Belt Tension Set Screws

- Tension the belts until there is approximately 1 1/2 inches of belt sag on conventional Rake-Up and SwathMaster pickups and SwathMaster Small Seed pickups, and 2 inches of belt sag on Rake-Up Small Seed pickups when lifting midway between rollers. This adjustment is shown in the Draper Belt Adjustment For Conventional/Small Seed Pickups.

- Tighten 1/2-inch carrier bracket bolts.

NOTE:

- When the pickup is mounted on the combine, there should be visible sag in the bottom side of the draper belt(s).
- Some draper belts when new are very tacky. Talcum or baby powder rubbed into the belts may help to reduce the tackiness. In addition, for the first few hours of break-in, the belts may need to be run looser than normal.

DRAPER BELTS TO BE TENSIONED ONLY ENOUGH TO PREVENT SLIPPAGE

P00664

DO NOT OVER-TIGHTEN THE BELTS!

This can cause a number of problems:

- Joining bolts can pull out of draper belts.
- The center belts will slip on conventional pickups.
- The belts will crawl over the dividers.
- The rollers or bearings could be damaged.

Any belts that fail from being over tightened will not be covered under warranty!

SECTION 3 – ADJUSTMENTS

B) Belt Alignment–SwathMaster Small Seed Pickups

If you are having trouble with the belts moving sideways out of the pulleys and wearing the belt edges, the following procedure should be followed:

- (a) First, check draper belt tension. An over tensioned draper belt will tend to crawl sideways more. If you are not sure, try loosening the belt very slightly and then re-evaluating.
- (b) Check that each side of the draper is tightened evenly. If the drapers are not tightened evenly, sometimes diagonal ripples will appear running across the belt. Generally, loosen the side that the ripples are moving away from at the rear roller.

3.7 FIBERGLASS ROD/SPRING WIRE ORIENTATION

The orientation of the spring wires and the fiberglass rods must be adjusted for different crop conditions.

- a) Adjust the spring wire tube so that the spring wires protrude up through the fiberglass rods as illustrated. This will protect the fiberglass rods from becoming damaged by the spring wire edges. Secure with the clevis pins.

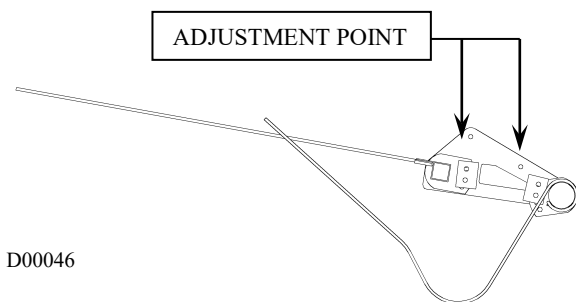

Spring Wire and Fiberglass Rod Adjustment



Hold-down Clevis and Hitch Pins

NOTE: To reduce shelling in heavy swaths, it may be necessary to rotate the spring wires completely out of the way.



Hold-down Adjusted for Short Crops



Hold-down Adjusted for Average Crops

SECTION 3 – ADJUSTMENTS



Hold-down Adjusted for Heavy Crops

NOTE: In some cases, if the hold-down assembly is moved substantially the suspension should be retuned. Rotate the spring wires clear before continuing to operate.

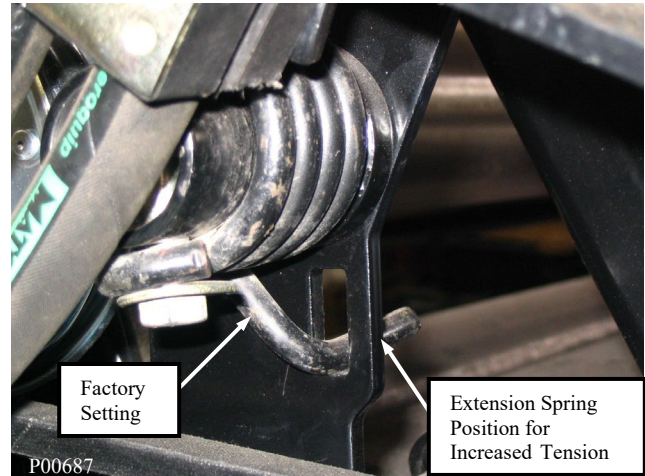

4. Tighten the tension spring hardware and put v-belt back on sheaves.

3.8 PICKUP DRIVE BELT TENSION

Both Rake-Up and SwathMaster models come equipped with self-tightening v-belts. SwathMaster units have an additional method to increase tension if required.

SwathMaster adjustment is as follows:

1. Remove drive shields. (See Section 3.2 in this Manual)
2. Eliminate v-belt tension. (See Service-Section 7 in the Operator's Manual)
3. Remove tension spring and reposition so the extension is outside the mount bracket.

3.9 SPEED CONTROL & HEIGHT CONTROL

3.9.1 JOHN DEERE

John Deere units are be equipped with the speed control and height control features. Adjust as follows:

Speed Control

In order for the speed control to operate effectively the sensor must be properly adjusted to read the target or sprocket teeth.

- Adjust up or down by loosening the 3/4" jam nuts. Adjust to a vertical clearance of 3/16"(5mm).
- Loosen the target sensor and slide it on the roller shaft until the desired horizontal clearance is achieved-the sensor should be centered on a sprocket tooth.
- When proper alignment is achieved, tighten the lower nut to lock the sensor into place and tighten the setscrew to maintain target adjustment.

SECTION 3 – ADJUSTMENTS

- Refer to your Operator Manual for optimum pick up speeds and your combine operator's manual for the combine portion of Dial-a-Speed operation.

ATTENTION: Loosen the lower nut first when removing or adjusting the sensor.

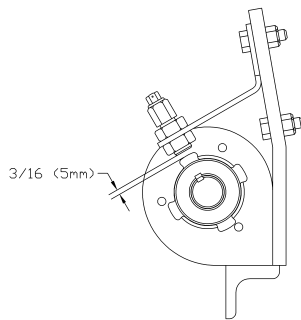

Sensor Details
(Target May Not Be As Shown)

D00126

Height Control

NOTE: Never make any adjustments to the AHC while the AHC unit is active in the combine. Adjusting the AHC unit will cause the feeder house to raise and lower.

Under normal conditions, the optimum pick up height is achieved when the rear draper roller is 14" off of the ground. For normal conditions you should set the AHC so that it is in the neutral position when the pickup rear roller is at the 14" mark. See following illustration.

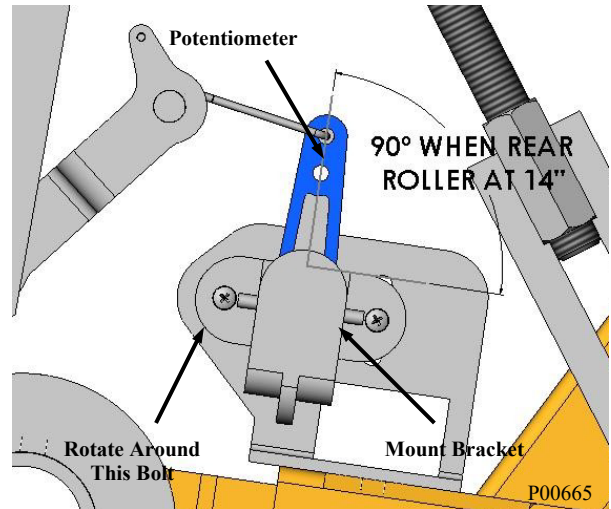

Components in Neutral Position

To set the AHC to this position:

- Disengage the AHC in the combine. Make sure the draper belts are properly tensioned. Each time the belts are adjusted, the AHC should be adjusted as well
- Lift the header until the rear draper roller is 14" from the ground.
- Loosen slightly, both nuts that hold the potentiometer to the mount bracket. Rotate the assembly around the left side bolt. The right bolt will move along the slot. When the arm on the potentiometer is perpendicular to the potentiometer bracket it is in the neutral position.
- Retighten the nuts so that the potentiometer is secure.
- Refer to your combine Operator's Manual for in-cab calibration procedure.
- Test the function of the AHC. If the front end of the pick-up goes up (as if going up a hill) the header height should move up to compensate. If the pick-up front goes down (as if dropping into a hole) the header should drop to compensate.

SECTION 3 – ADJUSTMENTS

3.9.2 **LEXION**

Lexion units are equipped with the speed control feature. In order for the speed control to operate properly the sensor and target are to be set using the below specification.

RAKE-UP

Loosen screw (3), and center the sensor (1) on the target (5). Tighten screw (3). Loosen the 2 nuts (4) and position the sensor assembly bracket (2) so the clearance between the target (5) and sensor (1) is approximately 2.5mm as shown. Tighten nuts (4).

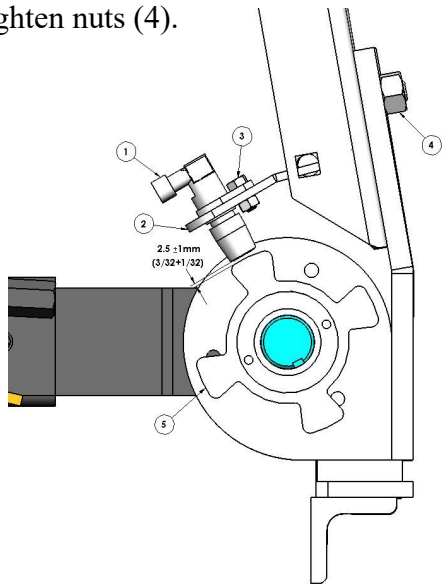

Rake Up Sensor Details

SWATHMASTER

Loosen the setscrew in the target hub (4) and slide along the shaft until the center point of the target (3) is in line with the center of the sensor (2).

There should be a clearance of approximately 3/16 inch between the highest point on the target lobe (3) and the sensor.

To adjust this clearance, loosen the nuts on the bolts (5) holding the speed sensor bracket (1) in place. Slide the bracket/sensor assembly up or down in the slots to achieve the desired clearance. Tighten the nuts.

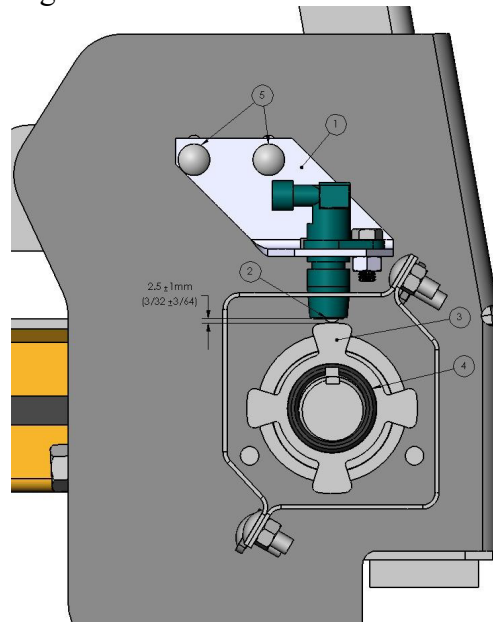

SwathMaster Sensor Details

SECTION 3 – ADJUSTMENTS

3.10 AUGER FINGER ADJUSTMENT

ATTENTION: Do not adjust fingers to less than the minimum 1/4-inch clearance to the header bottom.

Adjusting the fingers may be necessary to optimize performance in different crops.

Finger Adjustment Procedure

- a) Loosen the clamping nut.



Finger Adjustment

- b) Move the handle in the desired direction.
Counterclockwise = Fingers retract
Clockwise = Fingers extend
- c) When the desired position is found, tighten the clamping nut.

3.11 AUGER ADJUSTMENT

The auger is a very important component in getting a smooth, high capacity flow of crop into the feeder house. Factory auger setting is not intended to be field ready for all types of crops. The auger must be adjusted for different crop conditions.

The auger must also rotate freely without contacting the header floor or stripper bars. Check minimum factory clearance prior to operation.

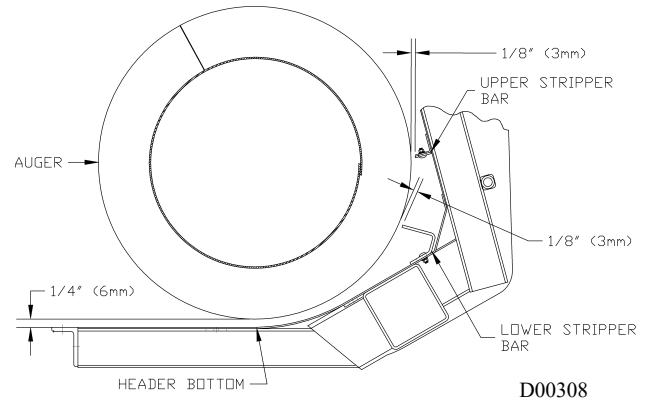

Factory Settings

A) Auger Clearance to Header Bottom

For heavy or bulky crops, a clearance of 25mm (1 inch) can increase header capacity.

For a lighter crop, a minimum clearance of 6mm (1/4 inch) will prove to be more effective.

ATTENTION: Auger contact with the header bottom will cause excess wear to components.

The clearance between auger and header bottom can be adjusted as follows:

Adjust both ends of the auger so clearances are the same across the width of the header.

- a) Loosen clamp bolts protruding through the rubber stopper and sidewall.
- b) Back off the lower auger height adjustment nuts.
- c) Turn the top nuts to raise and lower the auger.

SECTION 3 – ADJUSTMENTS

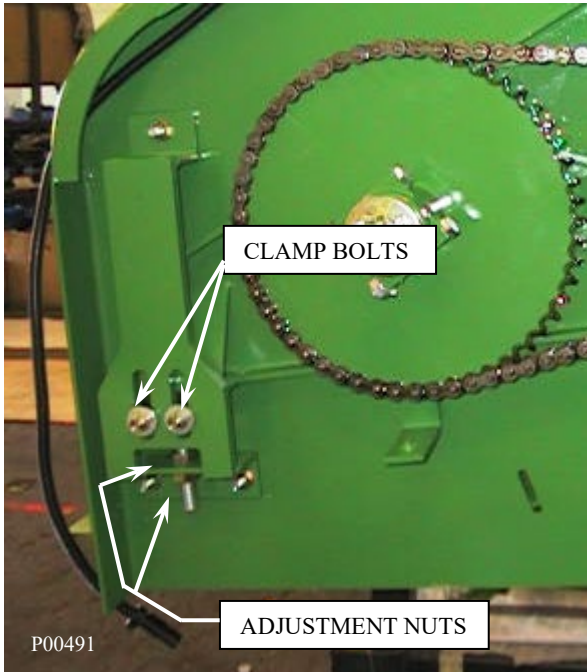

Auger Height Adjustment Nuts

- d) Turn the auger by hand and check for clearance along the entire length of the auger.
- e) Tighten the lower adjustor nuts.
- f) Tighten the clamp bolts.

Clearance between auger and strippers is to be rechecked after the auger height setting has been changed. See Auger Clearance to Stripper Bar.

B) Auger Forward/Rearward Adjustment

The auger can be moved forward or rearward to adjust stripper clearance or improve auger-feeding performance. The factory settings will prove very effective in most crop conditions. In some cases of small grain crops, the auger may be moved further ahead or back in the auger trough to improve performance.

Ensure that that the auger is adjusted evenly on both sides.

- a) Loosen the auger forward/rearward adjustment nut on both sides. See photo.
- b) Turn the rearward nut to pull the auger back to reduce clearance.
- c) Turn the forward nut to push the auger ahead to increase the clearance.
- d) Tighten the adjusting nuts to lock the auger in the desired position.

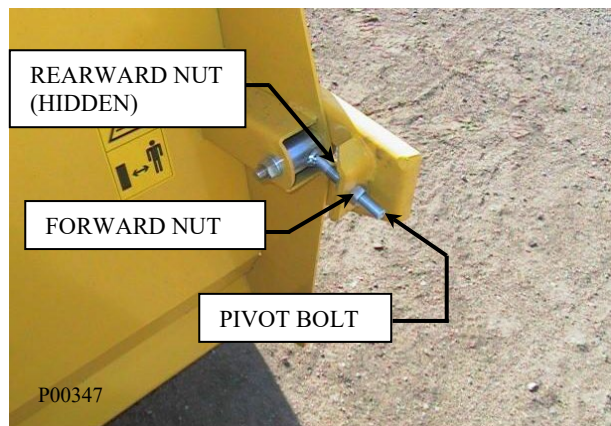

Forward/Rearward Adjustments

SECTION 3 – ADJUSTMENTS

3.12 STRIPPER BAR ADJUSTMENT

The header is equipped with a pair of upper and lower stripper bars.



DANGER: Lower header to the ground or engage feeder house locks, shut-off combine, remove ignition key, and wait for parts to stop moving before performing this adjustment

Stripping edge of the upper stripper bars on CNH models must be aligned with stripper bars on feeder house face.



Upper and Lower Stripper Bars

The clearance between the auger and stripper bars is set at the factory to a minimum of 2mm (3/32 inch). Minimizing the clearance of the auger and stripper bar can reduce crop carry over.

The upper stripper bar nuts are accessible from the top of the header.

A maximum reach of 16mm (5/8inch) can be accomplished by using the slotted holes in the upper stripper bar bracket and bar. If more clearance is desired, see Auger Forward/Rearward Adjustment.

ATTENTION: If the auger comes in contact with the stripper bar excessive wear will occur. Disconnect the drive shaft from combine and rotate auger by hand to find the minimum clearance, than complete all adjustments from that point.

3.13 HEADER DRIVE CHAIN ADJUSTMENT



DANGER: Lower header to ground or raise and engage feeder house locks, shut off combine, remove key and wait for all moving parts to stop before performing this adjustment.

The drive chain is factory adjusted to 1/8 inch deflection either way (1/4 inch total) at the tightest point in a full rotation. After a short run in period, adjust the chain to give 1/2 inch to 3/4-inch deflection at the bottom with approximately 10 lb (5kg) of force applied.

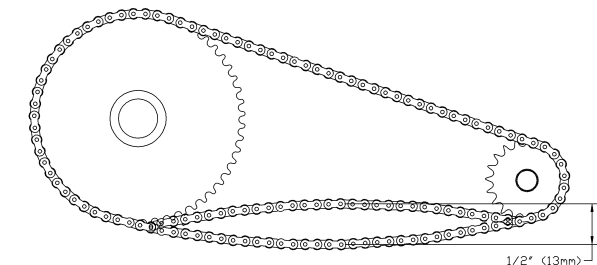

Drive Chain Deflection

SECTION 3 – ADJUSTMENTS

A) Procedure:

- a) Loosen the 4 drive shaft bracket bolts only enough to allow the bracket to slide in slots.



Drive Shaft Bracket Bolts

- b) Loosen the locknut on the chain tension bolt.

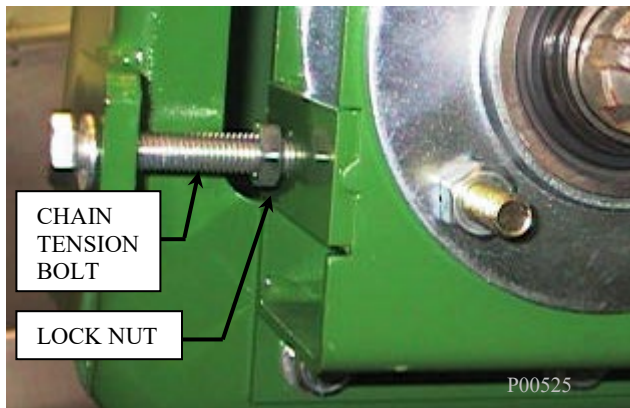

- c) To relieve the chain tension, turn the chain tension bolt counterclockwise.
- d) To tighten the chain, turn the chain tension bolt clockwise.
- e) Retighten the 4 drive shaft bracket bolts to 57 - 60 ft lb.
- f) Tighten the lock nut and to secure the chain tension bolt.
- g) Check chain tension.

ATTENTION: Attempting to adjust chain tension without loosening all four drive shaft bracket nuts will damage the chain tension bolt bracket.

NOTE: The side panel does not need to be removed for chain tension adjustment.



DANGER: Lower header to ground or raise and engage feeder house locks, shut off combine, remove key and wait for all moving parts to stop before performing this adjustment.

Chain tension can be checked with flat screwdriver using the access hole on the left side panel. See following picture.



Checking Chain Tension

MacDon™

MacDon Industries Ltd.

680 Moray Street
Winnipeg, Manitoba
Canada R3J 3S3
t. (204) 885-5590
f. (204) 832-7749

MacDon Inc.

10708 N. Pomona Avenue
Kansas City, Missouri
United States, 64153-1924
t. (816) 891-7313
f. (816) 891-7323

MacDon Australia Pty. Ltd.

A.C.N. 079 393 721
P.O. Box 243
Suite 3, 143 Main Street
Greensborough, Victoria
Australia 3088
t. 03 9432 9982
f. 03 9432 9972

CUSTOMERS

www.macdon.com

DEALERS

www.macdondealers.com

Trademarks of products are the marks of their
respective manufacturers and/or distributors.

Printed in Canada