

# **D50 and D60 Harvest Header FD70 FlexDraper Combine Header**

**IMPORTANT: PAGES 82–83  
HAVE BEEN UPDATED  
SINCE THIS MANUAL WAS  
PUBLISHED.**

**OPERATOR'S MANUAL**

Revision C

Part #169006 \$15

This Manual contains instructions for “SAFETY”, “OPERATION”, and “MAINTENANCE/SERVICE” information for your new MacDon Models D50 and D60 Harvest Header® and FD70 FlexDraper® for combines.



**D50 HARVEST HEADER®**



**D60 HARVEST HEADER®**



**FD70 FLEXDRAPER®**



# 1 INTRODUCTION

This manual contains information on the D50/D60 Harvest Headers, FD70 FlexDraper, and the CA20 Combine Adapter. It must be used in conjunction with your Combine Operator's Manual.

The FD70 FlexDraper header is specially designed as a "straight cut" header and is equipped to work well in all straight cut conditions, whether cutting on or above the ground, and utilizes a three piece flexible frame to closely follow ground contours.

The CA20 Combine Adapter allows any of the D and FD Series headers to be easily attached to your specific combine.

**CAREFULLY READ ALL THE MATERIAL PROVIDED BEFORE ATTEMPTING TO UNLOAD, ASSEMBLE, OR USE THE MACHINE.**

Use this manual as your first source of information about the machine. If you follow the instructions given in this manual, your Header will work well for many years. If you require more detailed service information, a Service Manual is available from your MacDon Dealer.

Use the Table of Contents and the Index to guide you to specific areas. Study the Table of Contents to familiarize yourself with how the material is organized.

Keep this manual handy for frequent reference and to pass on to new Operators or Owners.

A storage case for this manual is located inside the header left endshield.

Call your MacDon Dealer if you need assistance, information, or additional copies of this manual.

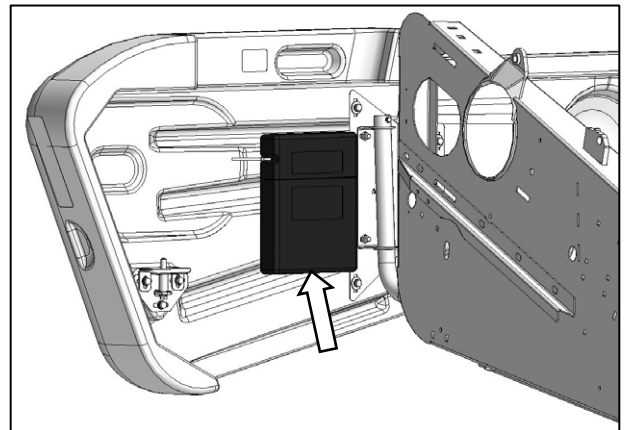

## 2 MODEL AND SERIAL NUMBER

**NOTE:** Right hand (RH) and Left-hand (LH) designations are determined from the Operator's position, facing forward.

Record the Model Number, Serial Number, and Model Year of the Header, Slow Speed Transport/Stabilizer Wheel Option (if installed), and the Combine Adapter on the lines below:

HEADER MODEL \_\_\_\_\_ SERIAL NO. \_\_\_\_\_ YEAR \_\_\_\_\_

Serial Number Plate is located on the left hand endsheet, near the knife drive motor.

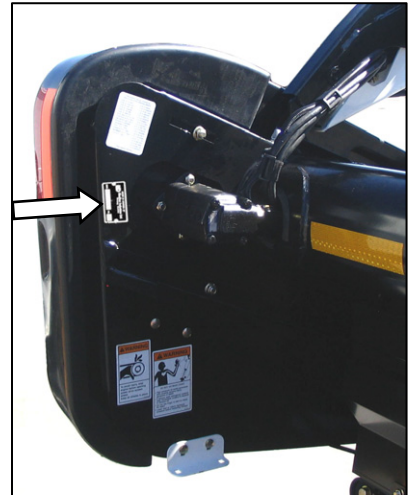

ADAPTER MODEL \_\_\_\_\_ SERIAL NO. \_\_\_\_\_ YEAR \_\_\_\_\_

Serial Number Plate is located on the frame above the main drive gearbox.

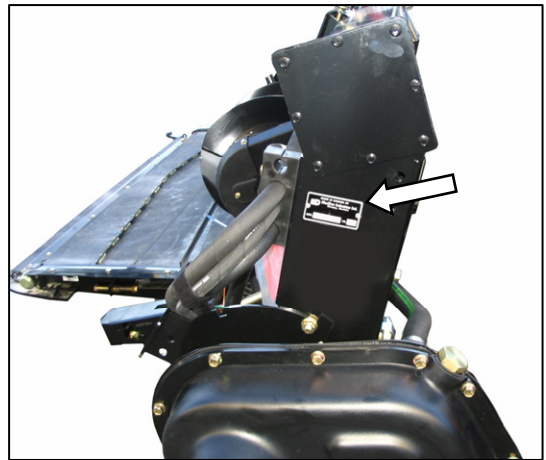

SLOW SPEED TRANSPORT/STABILIZER WHEEL OPTION

SERIAL NO. \_\_\_\_\_ YEAR \_\_\_\_\_

Serial Number Plate is located on the left hand wheel pivot tube.



# TABLE OF CONTENTS

Section/Title	Page
<b>1 INTRODUCTION .....</b>	<b>1</b>
<b>2 MODEL AND SERIAL NUMBER.....</b>	<b>2</b>
<b>3 SAFETY.....</b>	<b>7</b>
3.1 SAFETY ALERT SYMBOL.....	7
3.2 SIGNAL WORDS.....	7
3.3 SAFETY DECALS.....	7
3.3.1 Safety Decal Installation.....	7
3.3.2 Safety Decal Locations.....	8
3.4 GENERAL SAFETY.....	20
<b>4 ACRONYMS AND ABBREVIATIONS .....</b>	<b>22</b>
<b>5 COMPONENT IDENTIFICATION.....</b>	<b>23</b>
5.1 COMBINE HEADER.....	23
5.2 COMBINE ADAPTER.....	24
<b>6 SPECIFICATIONS.....</b>	<b>25</b>
<b>7 HEADER ATTACHMENT / DETACHMENT .....</b>	<b>27</b>
7.1 ADAPTER SET-UP .....	27
7.1.1 Center-Link Kit .....	27
7.1.2 Flighting Extensions.....	28
7.1.3 Stripper Bars.....	28
7.1.4 CR Feeder Deflectors .....	29
7.1.5 Auger Drive.....	29
7.2 CASE IH 7010, 8010, 7120, 8120, 5088, 6088, 7088 .....	30
7.2.1 Attachment.....	30
7.2.2 Detachment.....	32
7.3 CASE IH 2300, 2500 SERIES .....	34
7.3.1 Attachment.....	34
7.3.2 Detachment.....	37
7.4 JOHN DEERE 60, 70 SERIES.....	40
7.4.1 Attachment.....	40
7.4.2 Detachment.....	42
7.5 JOHN DEERE 50 SERIES .....	44
7.5.1 Attachment.....	44
7.5.2 Detachment.....	46
7.6 CAT LEXION 400, 500 SERIES .....	48
7.6.1 Attachment.....	48
7.6.2 Detachment.....	51
7.7 NEW HOLLAND CR, CX .....	54
7.7.1 Attachment.....	54
7.7.2 Detachment.....	56
7.8 AGCO.....	58
7.8.1 Attachment.....	58
7.8.2 Detachment.....	61
<b>8 HEADER/ADAPTER DISASSEMBLY AND ASSEMBLY .....</b>	<b>63</b>
8.1 D50 AND D60 HARVEST HEADER/ADAPTER.....	63
8.1.1 Disassembly.....	63
8.1.2 Assembly.....	66
8.2 FD70 FLEXDRAPER/ADAPTER.....	71
8.2.1 Disassembly.....	71
8.2.2 Assembly.....	75



# TABLE OF CONTENTS

<b>9</b>	<b>OPERATION .....</b>	<b>79</b>
9.1	OWNER/OPERATOR RESPONSIBILITIES .....	79
9.2	OPERATIONAL SAFETY .....	79
9.3	BREAK-IN PERIOD .....	80
9.4	PRE-SEASON CHECK.....	80
9.5	DAILY START-UP CHECK .....	81
9.6	SHUTDOWN PROCEDURE.....	81
9.7	HEADER CONTROLS.....	82
9.8	HEADER LIFT CYLINDER LOCK-OUTS.....	82
9.9	REEL PROPS .....	82
9.10	STORAGE .....	84
9.11	HEADER SET-UP .....	85
9.11.1	Header Operating Variables.....	89
9.11.2	Cutting Height.....	89
9.11.3	Header Float.....	92
9.11.4	Header Angle.....	96
9.11.5	Reel Speed.....	97
9.11.6	Ground Speed .....	98
9.11.7	Draper Speed .....	99
9.11.8	Knife Speed .....	100
9.11.9	Reel Height.....	100
9.11.10	Reel Fore-Aft Position .....	101
9.11.11	Reel Tine Pitch .....	105
9.11.12	Crop Dividers and Rods .....	107
9.12	DRAPER DEFLECTORS.....	110
9.12.1	Deflector Replacement.....	110
9.12.2	Deflector Rework.....	110
9.13	KNIFE HEAD SHIELD .....	111
9.14	HEADER LEVELLING .....	112
9.15	UNPLUGGING CUTTERBAR.....	113
9.16	UNPLUGGING ADAPTER.....	113
9.17	UPPER CROSS AUGER.....	114
9.18	TRANSPORTING HEADER .....	115
9.18.1	On the Combine .....	115
9.18.2	Towing.....	115
9.18.3	Converting from Transport to Field Position.....	116
9.18.4	Converting from Field to Transport Position.....	121
9.19	WINDROWING.....	124
9.19.1	Adapter Modification.....	124
<b>10</b>	<b>MAINTENANCE AND SERVICING .....</b>	<b>128</b>
10.1	PREPARATION FOR SERVICING.....	128
10.2	RECOMMENDED SAFETY PROCEDURES .....	128
10.3	MAINTENANCE SPECIFICATIONS.....	129
10.3.1	Recommended Torques.....	129
10.3.2	Roller Chain Installation.....	131
10.3.3	Sealed Bearing Installation.....	131
10.3.4	Recommended Fluids and Lubricants.....	132
10.3.5	Conversion Chart.....	133
10.4	ENDSHIELDS AND COVERS .....	134
10.4.1	Endshields .....	134
10.4.2	Linkage Cover (FD70 FLEXDRAPER ONLY).....	137
10.5	LUBRICATION.....	138
10.5.1	Greasing Procedure .....	138
10.5.2	Lubrication Points .....	138
10.5.3	Oiling Requirements.....	146
10.5.4	Auger Drive Chain Lubrication .....	147
10.5.5	Main Drive Gearbox Lubrication.....	147

## TABLE OF CONTENTS

10.6	HYDRAULICS .....	149
10.6.1	Reservoir .....	149
10.6.2	Hydraulic Oil Filter .....	151
10.6.3	Hoses and Lines .....	151
10.6.4	Hydraulic Schematics .....	152
10.7	ELECTRICAL .....	155
10.8	MAIN DRIVE .....	155
10.8.1	Driveline Removal .....	155
10.8.2	Driveline Installation .....	156
10.8.3	Guard Removal .....	156
10.8.4	Guard Installation .....	157
10.8.5	Drive Chain Adjustment .....	158
10.9	AUGER .....	159
10.9.1	Auger Pan Clearance .....	159
10.9.2	Auger Drive Chain Adjustment .....	160
10.9.3	Auger Drive Chain Replacement .....	160
10.9.4	Auger Tine Replacement .....	162
10.10	VIBRATION DAMPERS .....	164
10.10.1	Rubber Pad Replacement .....	164
10.11	SICKLE AND SICKLE DRIVE .....	165
10.11.1	Sickle Sections .....	165
10.11.2	Sickle Removal .....	166
10.11.3	Sickle Head Bearing Replacement .....	166
10.11.4	Sickle Installation .....	167
10.11.5	Spare Sickle (Single Knife Headers) .....	167
10.11.6	Sickle Guards .....	168
10.11.7	Sickle Hold-Downs .....	171
10.11.8	Sickle Drive Belts - Non Timed Drive .....	172
10.11.9	Double Knife Drive Belts - Timed Drive .....	173
10.11.10	Wobble Box .....	178
10.12	ADAPTER FEED DRAPER .....	181
10.12.1	Draper Tension Adjustment .....	181
10.12.2	Replacing Draper .....	181
10.13	HEADER DRAPERS .....	183
10.13.1	Header Draper Tension Adjustment .....	183
10.13.2	Replacing Split Draper .....	183
10.13.3	Header Draper Alignment .....	185
10.13.4	Draper Roller Maintenance .....	186
10.13.5	Deck Height .....	189
10.14	REEL AND REEL DRIVE .....	190
10.14.1	Reel Clearance to Cutterbar - D50, D60 .....	190
10.14.2	Reel Clearance to Cutterbar - FD70 .....	191
10.14.3	Reel Frown Adjustment .....	193
10.14.4	Reel Centering .....	193
10.14.5	Reel Drive Chain - D60, FD70 .....	194
10.14.6	Reel Drive Chain - D50 .....	198
10.14.7	Reel Drive Sprocket - D60, FD70 .....	199
10.14.8	Reel Drive Sprocket - D50 .....	200
10.14.9	Reel Drive U-Joint - D60, FD70 ONLY .....	201
10.14.10	Reel Drive Motor - D60, FD70 .....	202
10.14.11	Reel Drive Motor - D50 .....	203
10.14.12	Reel Speed Sensor .....	204
10.14.13	Reel Tines .....	207
10.14.14	Tine Tube Bushings .....	209
10.15	HEADER WING FLOAT .....	213
10.15.1	Wing Float Lock Adjustment .....	213
10.15.2	Wing Balance .....	213
10.15.3	Wing Linkage Adjustment .....	215

# TABLE OF CONTENTS

10.16	TRANSPORT SYSTEM.....	216
10.16.1	Wheel Bolt Torque.....	216
10.16.2	Axle Bolts.....	216
10.16.3	Tire Inflation.....	216
10.17	MAINTENANCE SCHEDULE.....	217
10.17.1	Break-In Inspections.....	217
10.17.2	Interval Maintenance.....	218
10.17.3	Maintenance Record.....	219
<b>11</b>	<b>TROUBLESHOOTING.....</b>	<b>221</b>
11.1	CROP LOSS AT CUTTERBAR.....	221
11.2	CUTTING ACTION AND SICKLE COMPONENTS.....	222
11.3	REEL DELIVERY.....	224
11.4	HEADER AND DRAPERS.....	226
11.5	FD70 FLEXDRAPER.....	228
11.6	CUTTING EDIBLE BEANS.....	229
<b>12</b>	<b>OPTIONS AND ATTACHMENTS.....</b>	<b>233</b>
12.1	AUTO HEADER HEIGHT CONTROLLER.....	233
12.2	KNIFE REVERSING KIT.....	233
12.3	FLOAT/ANGLE INDICATOR.....	233
12.4	HYDRAULIC HEADER TILT.....	233
12.5	CUTTERBAR POLY.....	234
12.6	ADJUSTABLE SKID SHOES WITH POLY COVER.....	234
12.7	STUB GUARD CONVERSION KIT.....	234
12.8	STABILIZER WHEELS.....	234
12.9	STABILIZER/TRANSPORT WHEELS.....	234
12.10	LODGED CROP REEL FINGER KIT.....	235
12.11	VERTICAL KNIFE MOUNTS.....	235
12.12	UPPER CROSS AUGER.....	235
12.13	REEL ENDSHIELD KIT.....	235
12.14	ROCK RETARDER KIT.....	236
12.15	RICE DIVIDER KIT.....	236
12.16	HYDRAULIC REEL FORE-AFT POSITIONER.....	236
12.17	CA20 DELICATE SEED SAVER KIT.....	236
12.18	KNIFE HEAD SHIELD.....	236
<b>13</b>	<b>UNLOADING AND ASSEMBLY.....</b>	<b>237</b>
	<b>INDEX.....</b>	<b>238</b>



## SECTION 3. SAFETY

### 3 SAFETY

#### 3.1 SAFETY ALERT SYMBOL



This safety alert symbol indicates important safety messages in this manual and on safety decals on the machine.

This symbol means:

- ATTENTION!
- BECOME ALERT!
- YOUR SAFETY IS INVOLVED!

Carefully read and follow the safety message accompanying this symbol.

#### WHY IS SAFETY IMPORTANT TO YOU?

- ACCIDENTS DISABLE AND KILL.
- ACCIDENTS COST.
- ACCIDENTS CAN BE AVOIDED.

#### 3.2 SIGNAL WORDS

Note the use of the signal words DANGER, WARNING, and CAUTION with safety messages. The appropriate signal word for each message has been selected using the following guidelines:



#### DANGER

Indicates an imminently hazardous situation that, if not avoided, will result in death or serious injury.



#### WARNING

Indicates a potentially hazardous situation that, if not avoided, could result in death or serious injury. It is also used to alert against unsafe practices.



#### CAUTION

Indicates a potentially hazardous situation that, if not avoided, may result in minor or moderate injury. It is also used as a reminder of good safety practices.

#### 3.3 SAFETY DECALS

- The safety decals appear on the header at the locations shown on pages 8 to 19.
- Keep safety decals clean and legible at all times.
- Replace safety decals that are missing or become illegible.
- If original parts on which a safety decal was installed are replaced, be sure the repair part also bears the current safety decal.
- Safety decals are available from your MacDon Dealer Parts Department.

##### 3.3.1 SAFETY DECAL INSTALLATION

- a. Be sure the installation area is clean and dry.
- b. Decide on the exact location before you remove the decal backing paper.
- c. Remove the smaller portion of the split backing paper.
- d. Place the decal in position and slowly peel back the remaining paper, smoothing the decal as it is applied.
- e. Small air pockets can be smoothed out or pricked with a pin.

## SECTION 3. SAFETY

### 3.3.2 SAFETY DECAL LOCATIONS

#### 3.3.2.1 3-Panel Safety Decals - North America

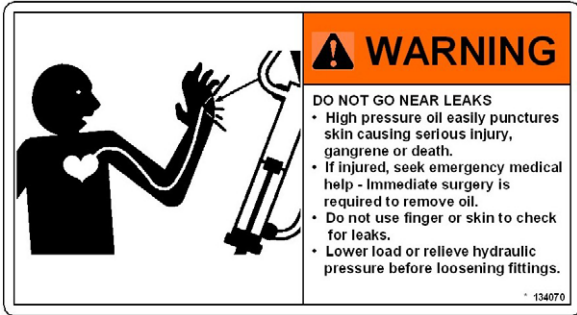

BACK TUBE #134070

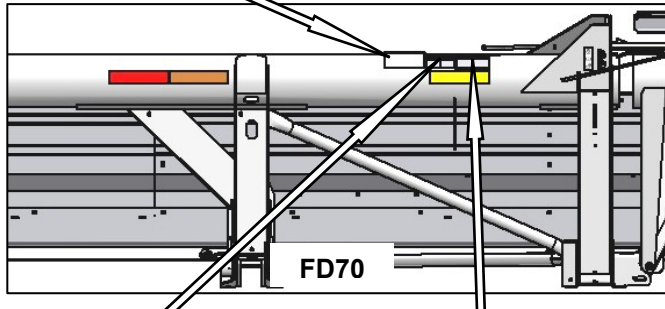

BACK TUBE - BOTH ENDS  
#172147



BACK TUBE #42122

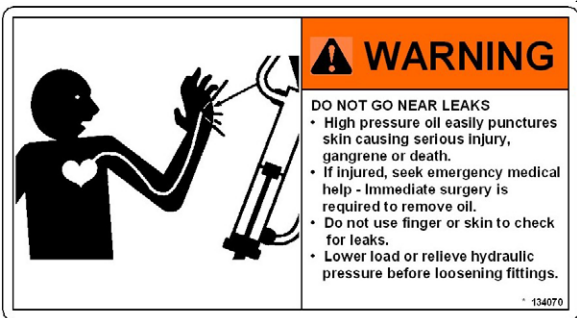
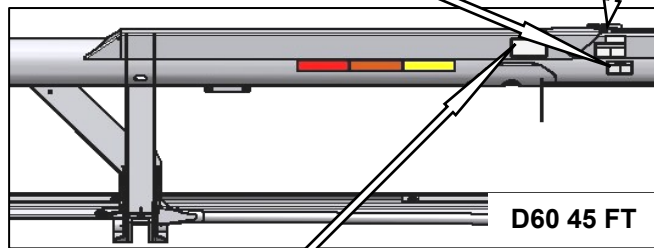

BACK TUBE #134070

## SECTION 3. SAFETY

### 3-Panel Safety Decals - North America (Cont'd)

**⚠ CAUTION**

To avoid injury or death from improper or unsafe machine operation:

1. Read the Operator's Manual, and follow all safety instructions. If you do not have a manual, obtain one from your dealer.
2. Do not allow untrained persons to operate the machine.
3. Review safety instructions with all operators annually.
4. Ensure that all safety signs are installed and legible.
5. Make certain everyone is clear of machine before starting engine and during operation.
6. Keep riders off the machine.
7. Keep all shields in place, and stay clear of moving parts.
8. Disengage header drive, put transmission in neutral and wait for all movement to stop before leaving operator's position.
9. Do not service, adjust, lubricate, clean or unplug machine with engine running or key in ignition.
10. Engage mechanical locks before servicing header or reel in the raised position.
11. Use slow moving vehicle emblem and flashing warning lights when operating on roadways unless prohibited by law.



\* 109843

**⚠ WARNING**

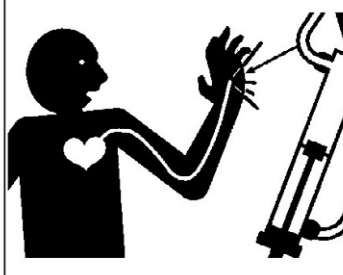

**DO NOT GO NEAR LEAKS**

- High pressure oil easily punctures skin causing serious injury, gangrene or death.
- If injured, seek emergency medical help - Immediate surgery is required to remove oil.
- Do not use finger or skin to check for leaks.
- Lower load or relieve hydraulic pressure before loosening fittings.

\* 134070

BACK TUBE #109843

BACK TUBE #134070

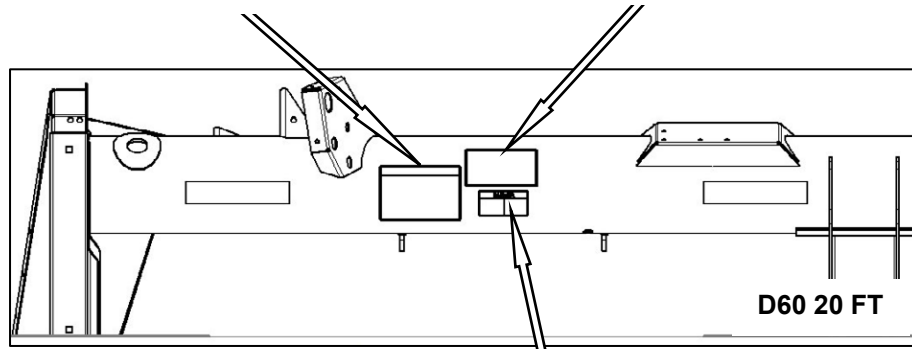

**⚠ DANGER**



**Rest header on ground or engage mechanical locks before going under unit. See Operators Manual.**

\* 172147

BACK TUBE & DECKS #172147

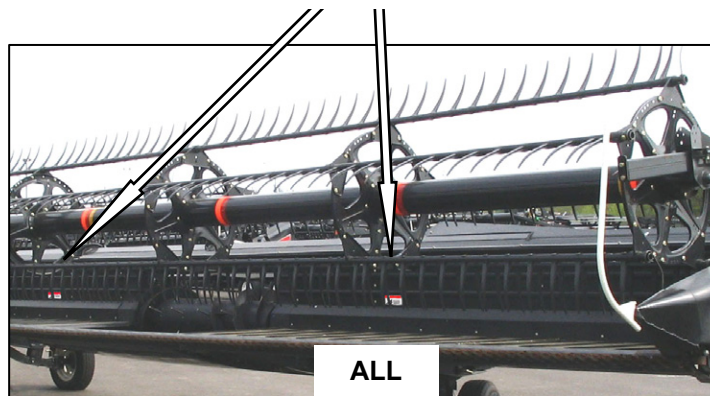



## SECTION 3. SAFETY

### 3-Panel Safety Decals - North America (Cont'd)

	<div style="background-color: orange; color: white; padding: 5px; font-weight: bold; font-size: 1.2em;"> <span style="font-size: 1.5em;">⚠</span> <b>WARNING</b> </div> <p><b>DO NOT GO NEAR LEAKS</b></p> <ul style="list-style-type: none"> <li>High pressure oil easily punctures skin causing serious injury, gangrene or death.</li> <li>If injured, seek emergency medical help - Immediate surgery is required to remove oil.</li> <li>Do not use finger or skin to check for leaks.</li> <li>Lower load or relieve hydraulic pressure before loosening fittings.</li> </ul> <p style="text-align: right; font-size: 0.8em;">* 134070</p>
---	--

BACK TUBE #134070

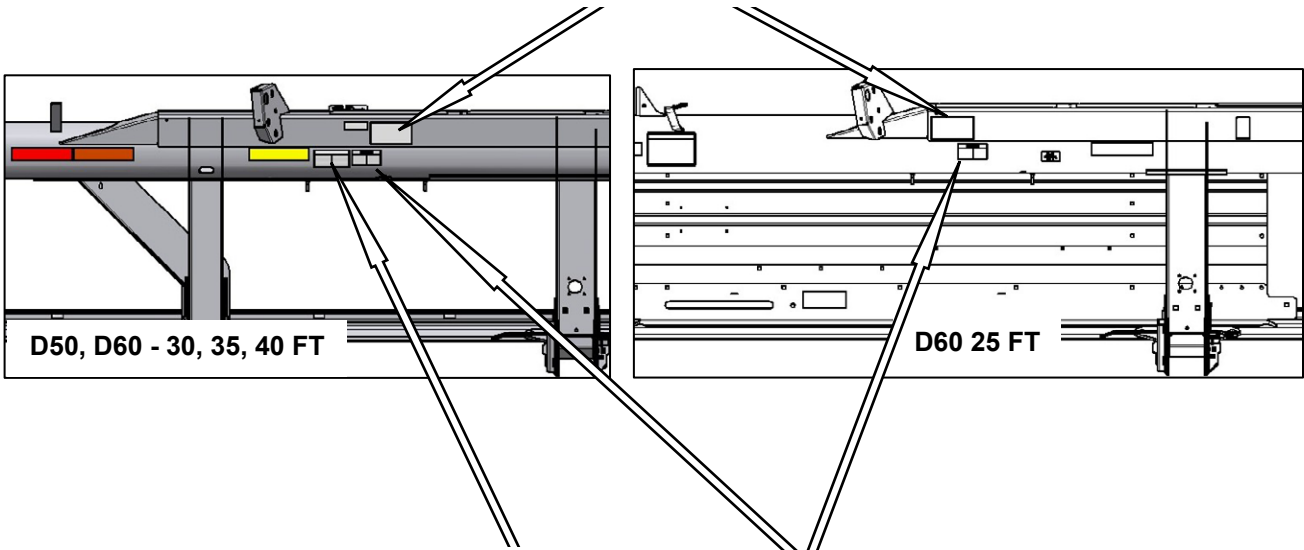

<span style="font-size: 1.5em;">⚠</span> <b>WARNING</b>	
	<p>To avoid injury from fall of raised reel; fully raise reel, stop engine, remove key, and engage mechanical lock on each reel support arm before working on or under reel. See Operator's Manual.</p> <p style="text-align: right; font-size: 0.8em;">*42122</p>

BACK TUBE - DOUBLE REEL ONLY  
#42122

<span style="font-size: 1.5em;">⚠</span> <b>DANGER</b>	
	<p><b>Rest header on ground or engage mechanical locks before going under unit. See Operator's Manual.</b></p> <p style="text-align: right; font-size: 0.8em;">* 172147</p>

BACK TUBE BOTH ENDS  
#172147

# SECTION 3. SAFETY

## 3-Panel Safety Decals - North America (Cont'd)

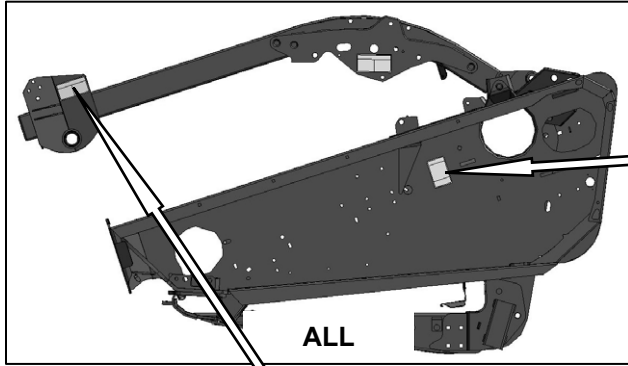

BOTH ENDS - DOUBLE KNIFE  
 LEFT END - SINGLE KNIFE  
 #142909



LH & RH REEL ARMS  
 #174633

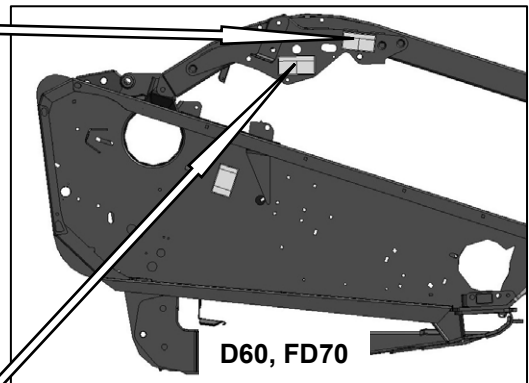

LH & RH REEL ARMS  
 #42122

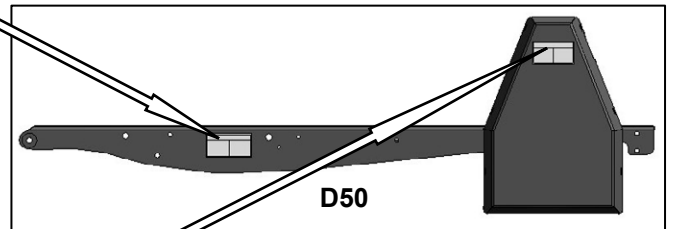

REEL ARMS  
 #174633

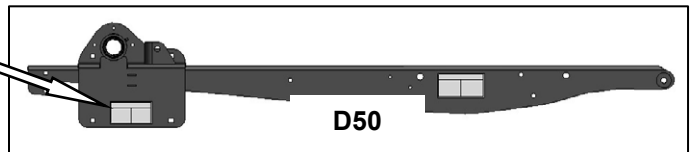

# SECTION 3. SAFETY

## 3-Panel Safety Decals - North America (Cont'd)



DRIVELINE  
#30316



INSIDE DRIVELINE GUARD  
#36651

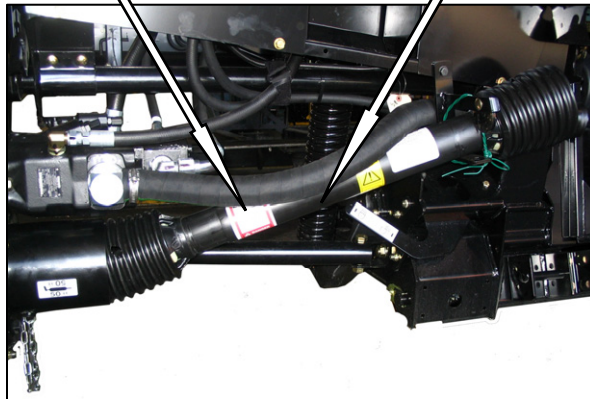



# SECTION 3. SAFETY

## 3.3.2.2 2-Panel Safety Decals - North America and Export

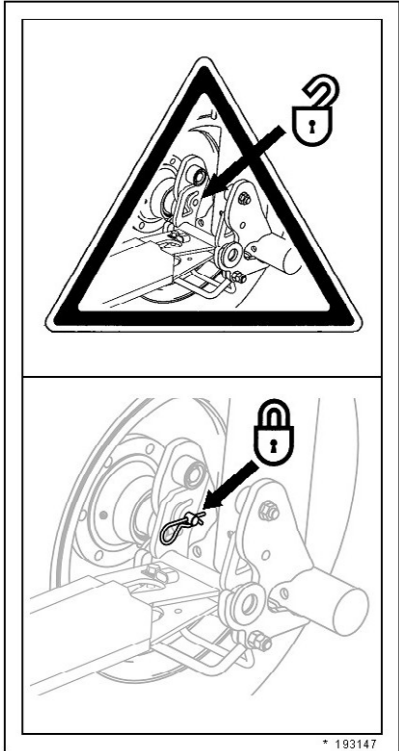

FRONT TRANSPORT LEG  
#193147

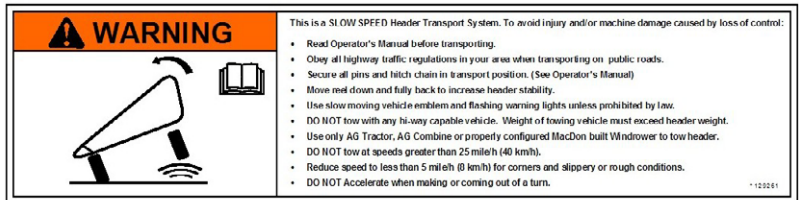
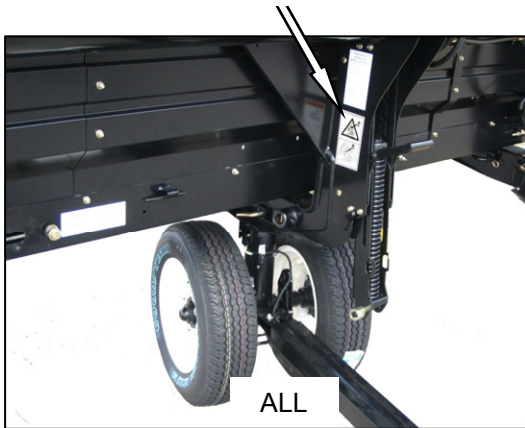

TOW-BAR  
#129261

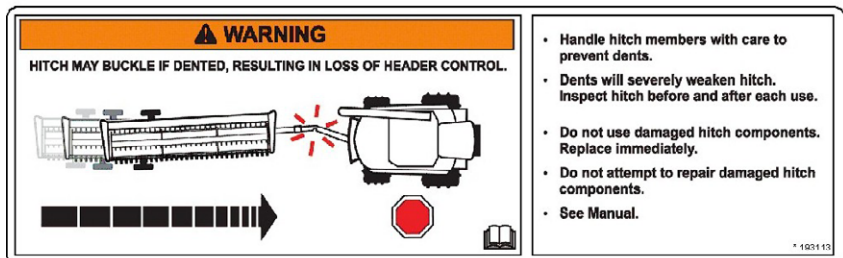
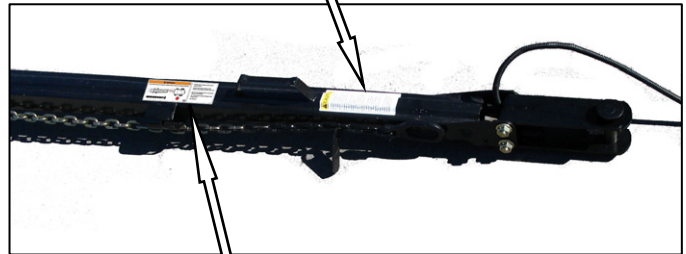

TOW-BAR  
#193113

### SECTION 3. SAFETY

#### 2-Panel Safety Decals - North America and Export (Cont'd)



UPPER CROSS AUGER  
#174682

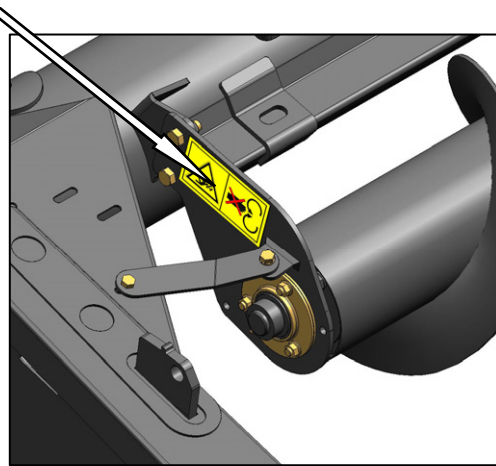
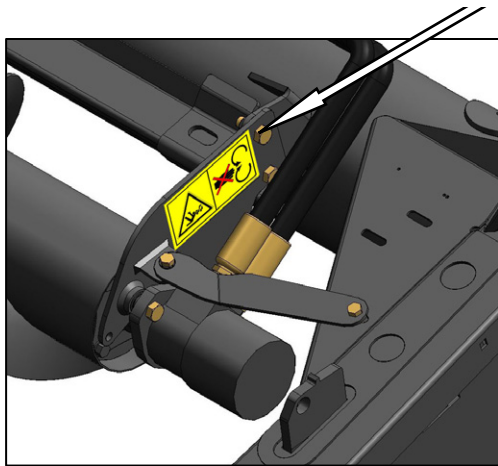

LH AND RH  
VERTICAL KNIFE  
#174684

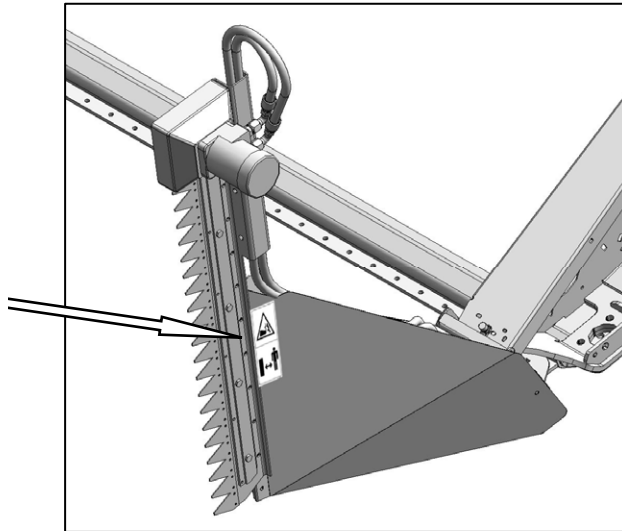

SECTION 3. SAFETY

3.3.2.3 2-Panel Safety Decals - Export

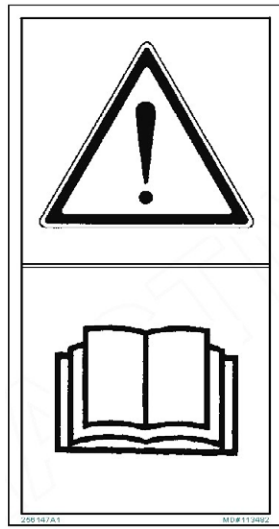

BOTH ENDS #113482

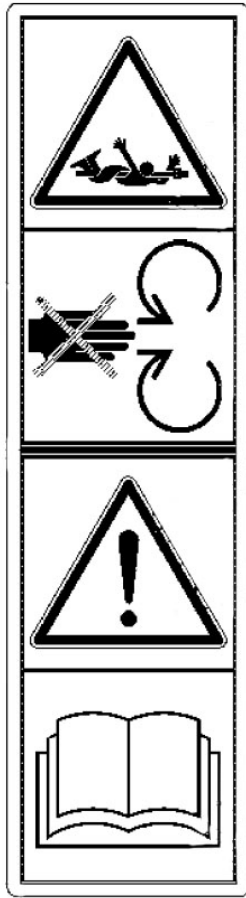
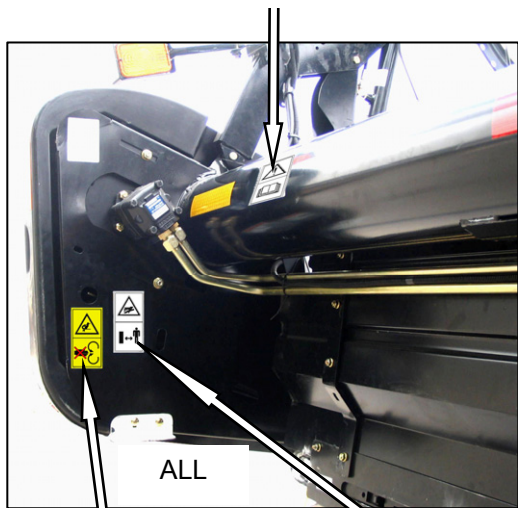
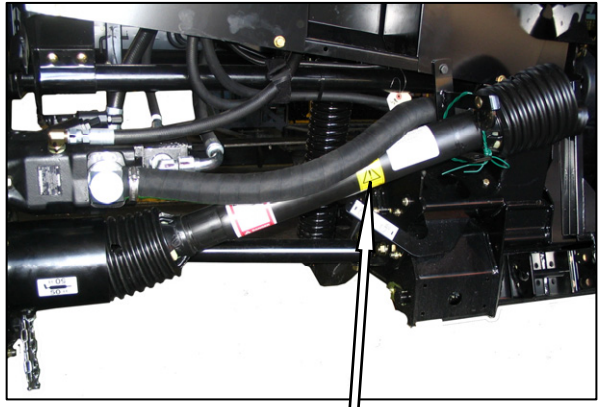

DRIVELINE #194521



BOTH ENDS - DOUBLE KNIFE  
LEFT END - SINGLE KNIFE  
#184371



BOTH ENDS #174436

SECTION 3. SAFETY

2-Panel Safety Decals- Export (Cont'd)

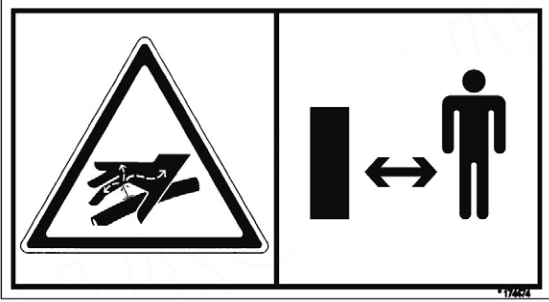

BACKTUBE #174474

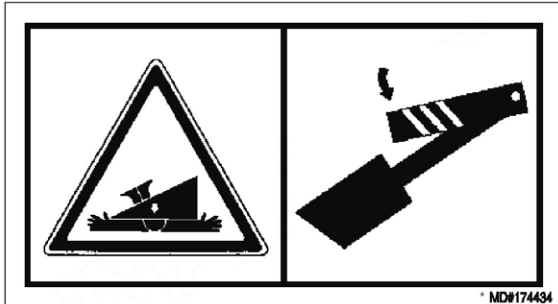
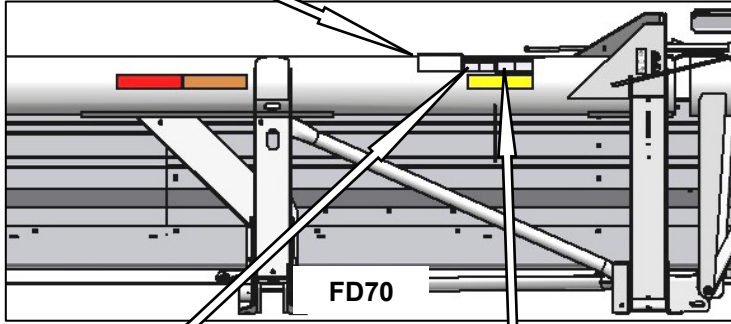

BACKTUBE - BOTH ENDS #174434



BACKTUBE #174432

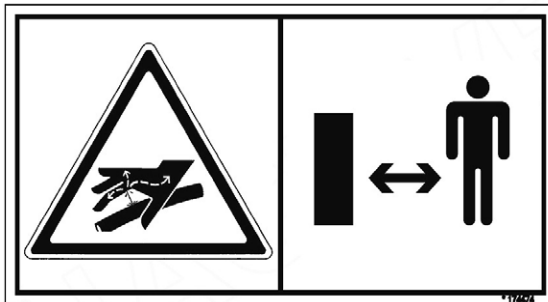
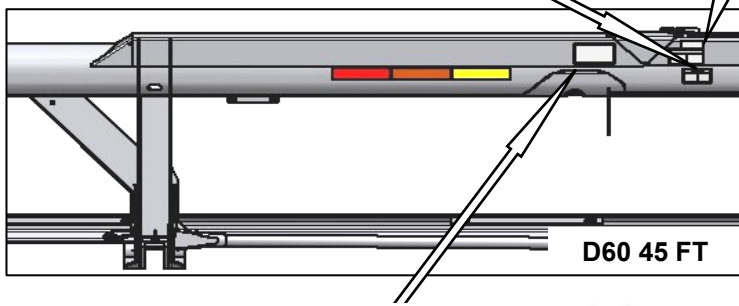

BACKTUBE #174474

# SECTION 3. SAFETY

## 2-Panel Safety Decals- Export (Cont'd)

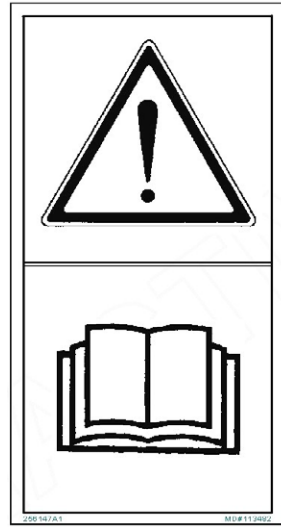

BOTH ENDS #113482

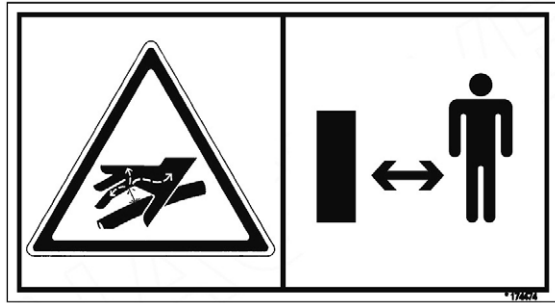

BACKTUBE #174474

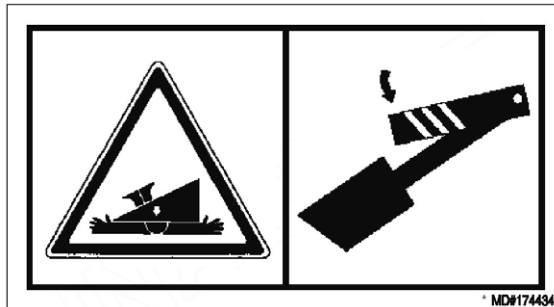
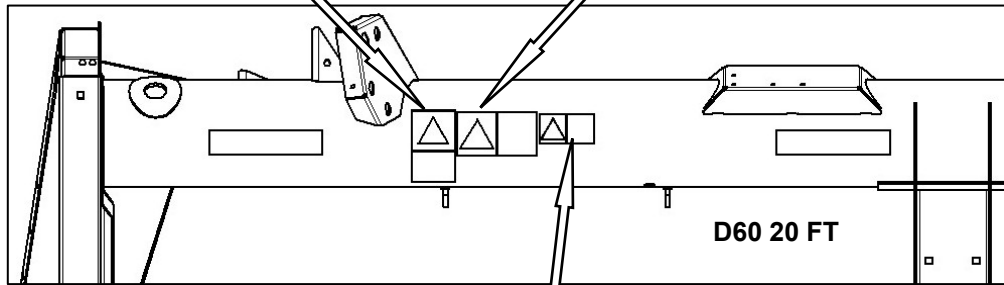

BACKTUBE AND DECKS #174434

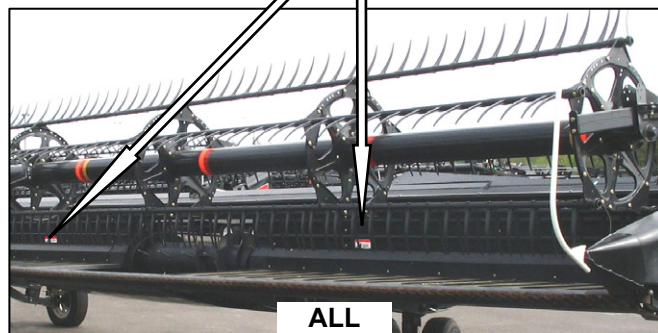

# SECTION 3. SAFETY

## 2-Panel Safety Decals- Export (Cont'd)

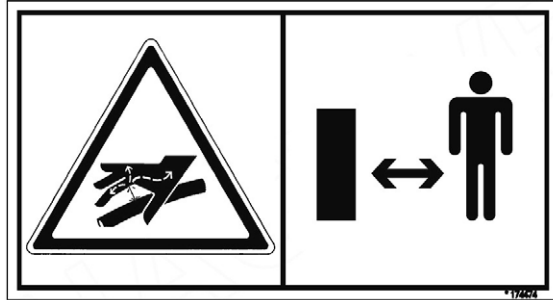

BACK TUBE - BOTH ENDS  
#174474

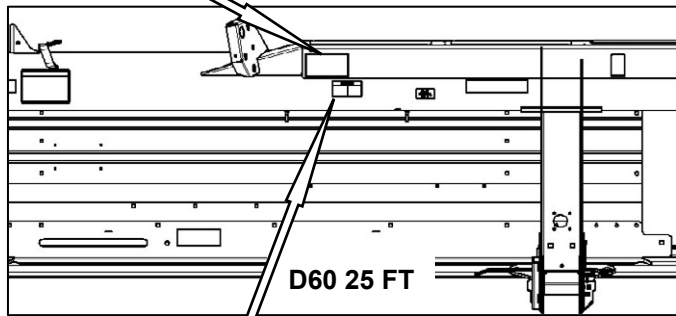
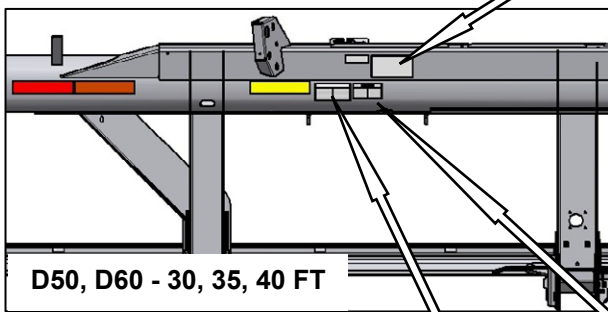

BACK TUBE - DOUBLE REEL ONLY  
#174432

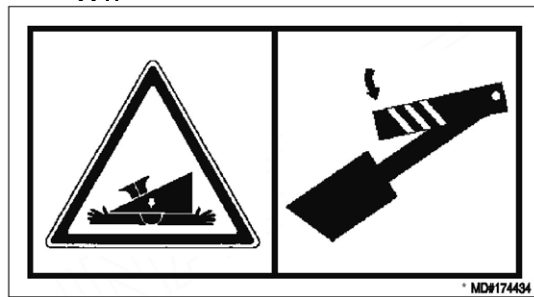

BACK TUBE - BOTH ENDS  
#174434



# SECTION 3. SAFETY

## 2-Panel Safety Decals- Export (Cont'd)

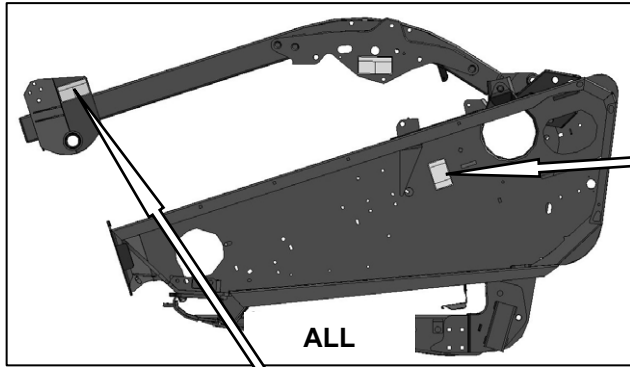

BOTH ENDS - DOUBLE KNIFE  
LEFT END - SINGLE KNIFE  
#184371

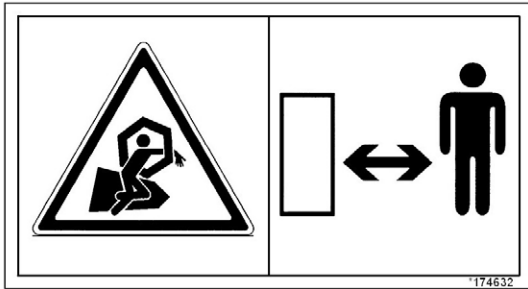

REEL ARMS  
#174632

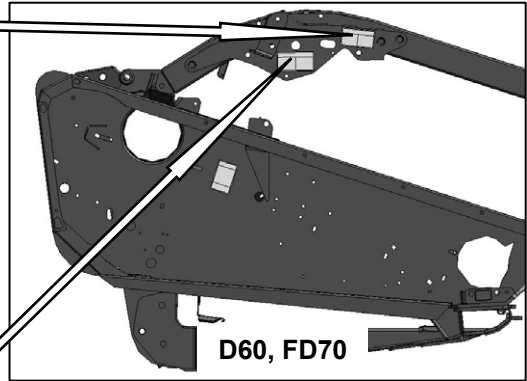

LH & RH REEL ARM  
#174432

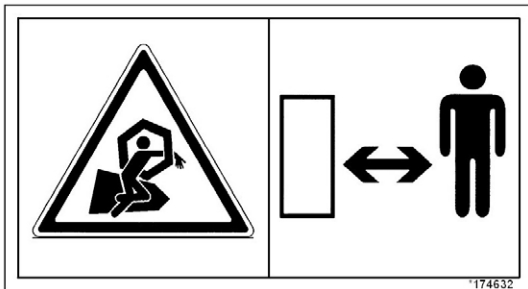
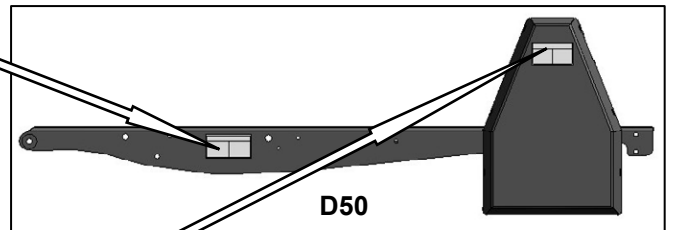

REEL ARMS  
#174632

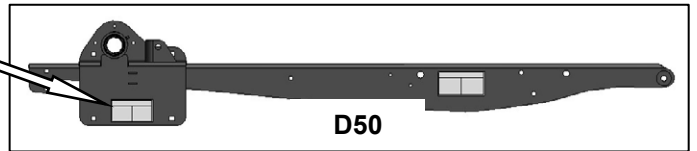



## SECTION 3. SAFETY

### 3.4 GENERAL SAFETY



#### CAUTION

The following are general farm safety precautions that should be part of your operating procedure for all types of machinery.

- Protect yourself. When assembling, operating and servicing machinery, wear all the protective clothing and personal safety devices that **COULD** be necessary for the job at hand. Don't take chances.
- You may need:

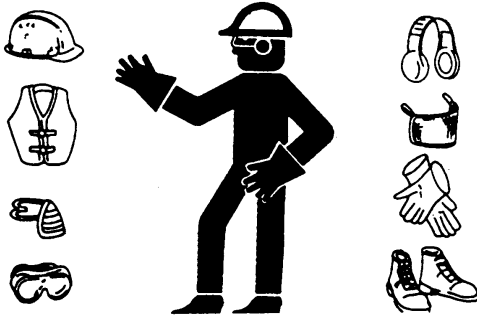

- a hard hat.
- protective shoes with slip resistant soles.
- protective glasses or goggles.
- heavy gloves.
- wet weather gear.
- respirator or filter mask.
- hearing protection. Be aware that prolonged exposure to loud noise can cause impairment or loss of hearing. Wearing a suitable hearing protective device such as ear muffs (A) or ear plugs (B) protects against objectionable or loud noises.



- Provide a first-aid kit for use in case of emergencies.
- Keep a fire extinguisher on the machine. Be sure the extinguisher is properly maintained and be familiar with its proper use.
- Keep young children away from machinery at all times.
- Be aware that accidents often happen when the Operator is tired or in a hurry to get finished. Take the time to consider the safest way. Never ignore warning signs of fatigue.
- Wear close-fitting clothing and cover long hair. Never wear dangling items such as scarves or bracelets.
- Keep hands, feet, clothing and hair away from moving parts. Never attempt to clear obstructions or objects from a machine while the engine is running.

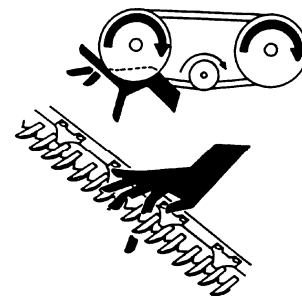

- Keep all shields in place. Never alter or remove safety equipment. Make sure driveline guards can rotate independently of the shaft and can telescope freely.

### SECTION 3. SAFETY

- Use only service and repair parts made or approved by the equipment manufacturer. Substituted parts may not meet strength, design, or safety requirements.
- Do not modify the machine. Unauthorized modifications may impair the function and/or safety and affect machine life.
- Stop engine and remove key from ignition before leaving Operator's seat for any reason. A child or even a pet could engage an idling machine.



- Keep the area used for servicing machinery clean and dry. Wet or oily floors are slippery. Wet spots can be dangerous when working with electrical equipment. Be sure all electrical outlets and tools are properly grounded.
- Use adequate light for the job at hand.
- Keep machinery clean. Straw and chaff on a hot engine are a fire hazard. Do not allow oil or grease to accumulate on service platforms, ladders or controls. Clean machines before storage.
- Never use gasoline, naphtha or any volatile material for cleaning purposes. These materials may be toxic and/or flammable.
- When storing machinery, cover sharp or extending components to prevent injury from accidental contact.

## SECTION 4. ACRONYMS AND ABBREVIATIONS

### 4 ACRONYMS AND ABBREVIATIONS

TERM	DEFINITION
API	American Petroleum Institute
ASTM	American Society Of Testing And Materials
C	Centigrade
DK	Double Knife
F	Fahrenheit
ft	feet
ft/min	feet per minute
ft/s	feet per second
gpm	U.S. gallons per minute
hp	horsepower
in.	inch
in. <sup>3</sup>	cubic inches
lb	pounds mass
lbf	pounds force
lbf·ft or ft·lbf	pound feet or foot pounds
lbf·in. or in·lbf	pound inches or inch pounds
mph	miles per hour
n/a	not applicable
oz.	ounces
psi	pounds per square inch
rpm	revolutions per minute
spm	strokes per minute
SAE	Society Of Automotive Engineers
SK	Single Knife

## SECTION 5. COMPONENT IDENTIFICATION

### 5 COMPONENT IDENTIFICATION

#### 5.1 COMBINE HEADER

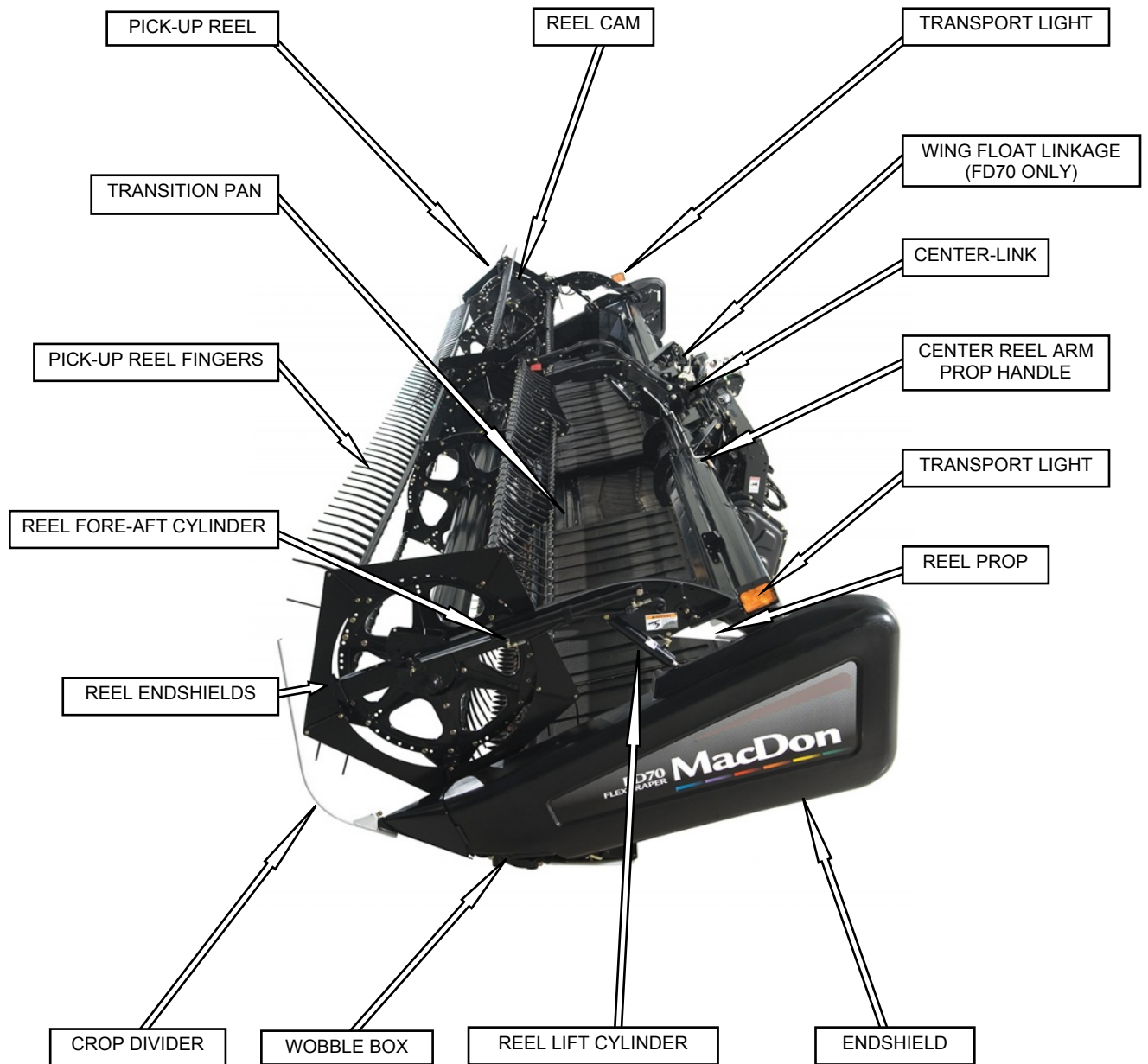

## SECTION 5. COMPONENT IDENTIFICATION

### 5.2 COMBINE ADAPTER

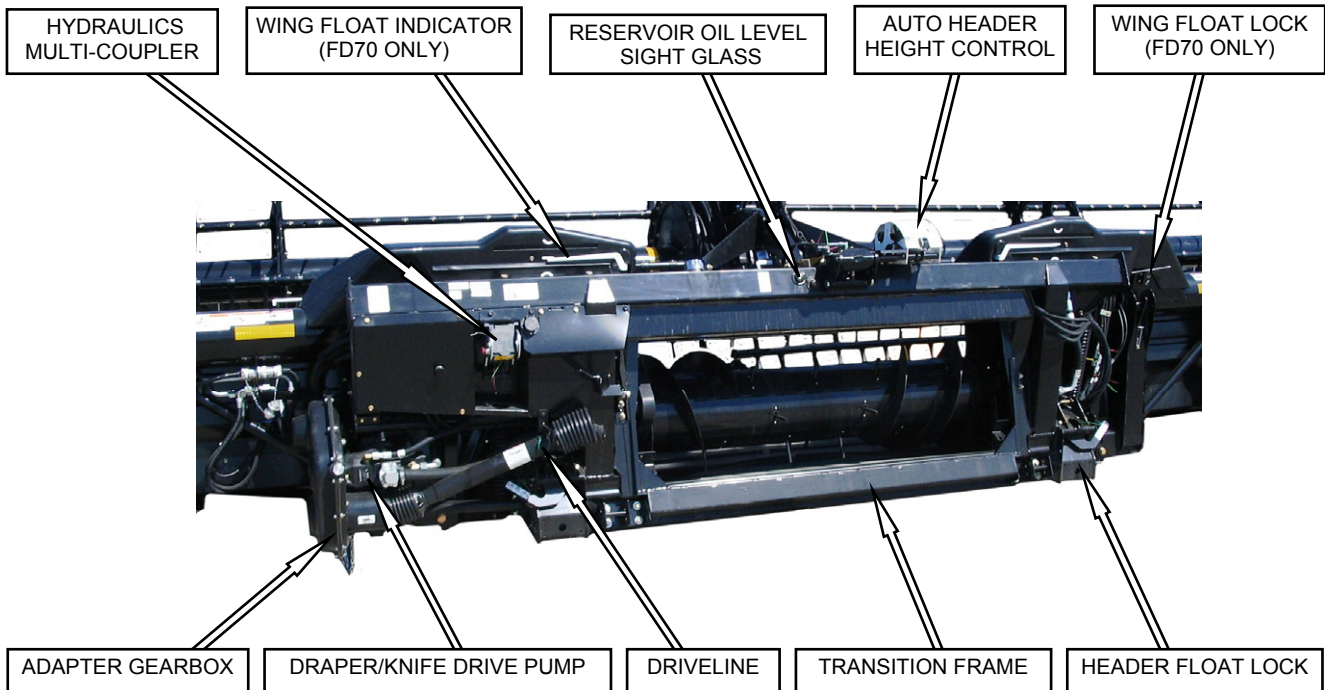
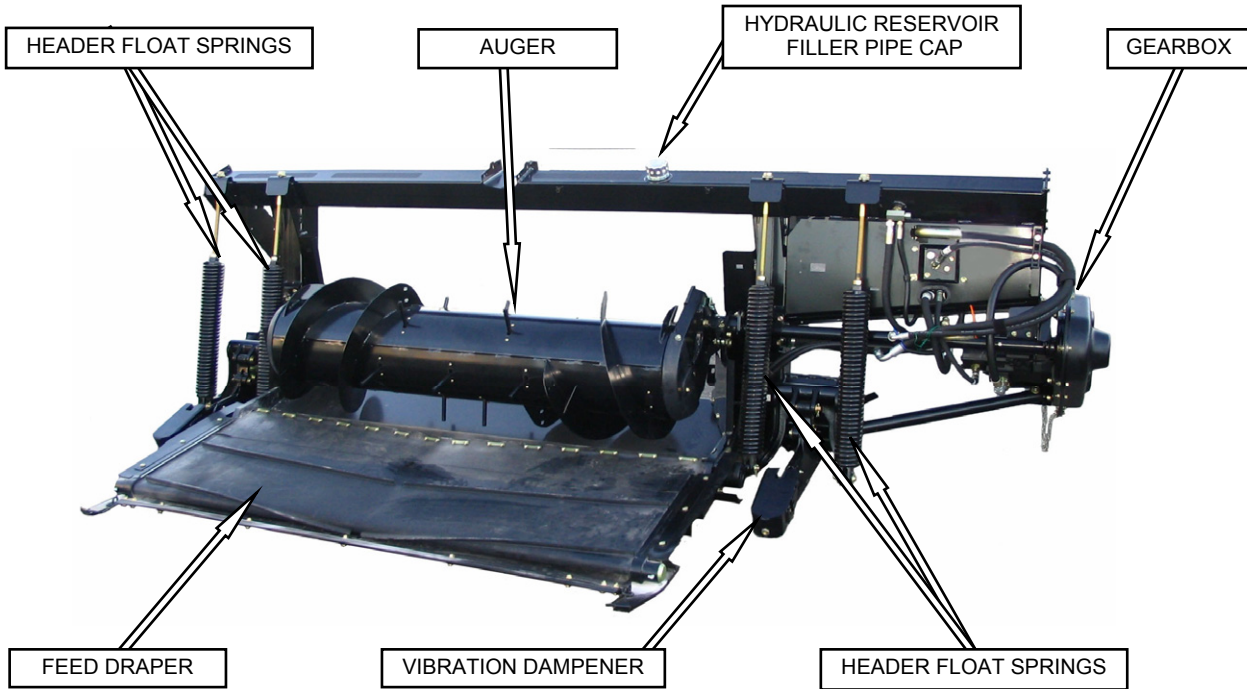

## SECTION 6. SPECIFICATIONS

### 6 SPECIFICATIONS

HEADER MODEL		D60	D50/D60	D50/D60/FD70		D60/FD70	D60/FD70	
HEADER SIZE		20 FT.	25 FT.	30 FT.	35 FT.	40 FT.	45 FT.	
<b>OVERALL</b>								
Width [Inches (mm)]	Transport (Reel Full Aft) With CA20 Adapter		96 (2438)					
	Field		255.1 (6479)	315.1 (8003)	375.1 (9527)	435.1 (11051)	495.1 (12575)	555.1 (14099)
Length [Inches (mm)]	Transport (with Tow Pole)	D50, D60	Not Applicable		505.7 (12845)	547.5 (13907)	601.5 (15278)	631.5 (16040)
		FD70	Not Applicable		513.0 (13029)	556.7 (14141)		
Height -Transport		97 in. (2464 mm)						
Estimated Weight Range Base Header - No Adapter [lb (kg)]		D50	Not Applicable	3500 (1589)	4150 (1884)	4700 (2134)	Not Applicable	
		D60	3400 (1544)	3500 - 4100 (1589 - 1861)	4200 - 5100 (1907 - 2315)	4700 - 5700 (2134 - 2588)	5400 - 5800 (2451 - 2633)	6200 (2815)
		FD70	Not Applicable		4850 (2202)	5250 (2384)	5700 - 5900 (2588 - 2979)	6300 (2860)
<b>CUTTERBAR</b>								
Width [Inches (mm)]			240 (6096)	300 (7620)	360 (9144)	420 (10668)	480 (12192)	540 (13716)
Header Cutting Height	Shortest Center-Link		1.3 in. (32 mm) below ground - 52.3 in. (1328 mm) above		0.8 in. (20 mm) below ground - 52.8 in. (1340 mm) above			
	Longest Center-Link		4.6 in. (117 mm) below ground - 46.9 in. (1192 mm) above		4.1 in. (105 mm) below ground - 47.4 in. (1204 mm) above			
Guard Angle (Cutterbar on Ground)		7.0° - 12.4°			2.0° - 7.4°			
<b>SICKLE</b>								
Drive Type	SK		Hydraulic Motor / 'C' Belt/Heavy Duty (MD) Wobble Box					
	DK (Except D50)		Hydraulic Motor / Two 'B' Timing Belts / Two Heavy Duty (MD) Wobble Boxes			Two Hydraulic Motors To "C" Belts, Untimed To Heavy Duty (MD) Wobble Boxes.		
Sickle Speed	SK		1200 Strokes Per Minute				Not Applicable	
	DK		1380 Strokes Per Minute					
Stroke		3 in. (76 mm)						
Sections - Over-Serrated & Bolted (serrations/inch)	Cut-Out or Solid		14		9 / 14		9	
Guards & Hold-Downs	Pointed	D50	Not Applicable	Pointed / Case Hardened / Sheet Metal / Adjuster Bolt			Not Applicable	
		D60	Case Hardened or Double Heat Treated / Sheet Metal / Adjuster Bolt					
		FD70	Not Applicable		Double Heat Treated / Sheet Metal / Adjuster Bolt			
	Stub (Except D50)		Sheet Metal HD	Sheet Metal or Forged HD	Not Applicable			
<b>CONVEYOR &amp; DECKS</b>								
Draper Drive		Hydraulic						
Draper Width		41.6 in. (1057 mm)						
Draper Speed		247 - 464 ft/min (75 - 141 m/min)						
Delivery Opening	Width	D50	Not Applicable	73.6 in. (1870 mm)			Not Applicable	
		D60	73.6 in. (1870 mm)					
		FD70	Not Applicable		73.6 in. (1870 mm)			
	Height		37.2 - 41.7 in. (945-1058 mm)					
Draper Angle (Cutterbar on Ground)	D50, D60		13.0° - 18.4°					
	FD70		Not Applicable		14.0° - 19.4°			

## SECTION 6. SPECIFICATIONS

HEADER MODEL		D60	D50/D60	D50/D60/FD70		D60/FD70	D60/FD70
HEADER SIZE		20 FT.	25 FT.	30 FT.	35 FT.	40 FT.	45 FT.
<b>REEL</b>							
Drive		Hydraulic From Combine Hydraulic Oil Supply					
Speed		0 - 67 rpm					
Quantity of Tine Tubes		6 / 9	5 / 6 / 9	5 / 6	5		
Effective Reel Diameter		65 in. (1650 mm)					
Finger Tip Radius Range		30.2 - 31.5 in. (766 - 800 mm)					
Finger Type	Plastic	---	Standard				
	Heavy Duty Plastic	Std.	Optional D60 & 30 ft. FD70	Opt. D60 DK	---		
Finger Spacing		6.0 in. (152.4 mm)					
<b>UPPER CROSS AUGER</b>							
Outside Diameter		12 in. (305 mm)					
Weight [lb (kg)]		163 (74)	192 (87)	221 (100)	250 (113)	279 (127)	308 (140)
<b>STABILIZER WHEELS</b>							
Size		ST205 / 75R-15					
Pressure		Load Range E - 80 psi (552 kPa) Load Range D - 65 psi (448 kPa)					
Weight		200 lb (91 kg)					
<b>COMBINE ADAPTER</b>							
Width		151 inches (3835 mm)					
Length		70 inches (1778 mm)					
Height		50 inches (1270 mm)					
Weight		2050 lb (930 kg)					
Main Drive		Combine Driven Piston Pump and Gear Pump Through Gearbox					
Gearbox Capacity		5 Pints (2.5 liters)					
Auger	Drive	Chain					
	Type	Auger - 14 inches (356 mm) with 4 inch (102 mm) Flighting					
	Speed	150 rpm (Combine Dependent)					
Feed Draper	Drive	Hydraulic Motor from Combine Driven Pump					
	Type	Self-Tracking Rubber Coated Polyester Fabric With Rubber Slats					
	Width	78.7 inches (2000 mm)					
	Speed	350 - 400 ft / min (107 - 122 meters / min)					
Reservoir Capacity		16 U.S. gal (60 liters)					
Maximum Operating Pressure		3500 psi (24132 kPa) Piston Pump, 3700 psi (25510 kPa) Gear Pump					
Filter		10 micron #151975					
Header Draper Drive Pump		1.01 in. <sup>3</sup> (16.5 cc) Gear Pump					
Sickle Drive Pump		1.8 - 2.7 in. <sup>3</sup> (29.5 - 44.2 cc) Piston Pump					
Adapter Header Flotation		7 - 8 Inches (178 - 203 mm) Vertical, 4 Degrees Rotation					
Header Angle Control		Mechanical or Hydraulic From Combine Hydraulic Oil Supply (With Solenoid Valve To Toggle To Reel Fore-aft / Header Tilt)					
Combine Requirement		Class 5 or Higher					

NOTES: 1. Specifications and design are subject to change without notice or obligation to revise previously sold units.  
2. Weights do not include options.

## SECTION 7. HEADER ATTACHMENT/DETACHMENT

### 7 HEADER ATTACHMENT / DETACHMENT

The header/adapter is configured to each particular model of combine at the factory. These combines are:

COMBINE	SECTION
Case IH 7010, 8010, 7120, 8120, 5088, 6088, 7088	7.2
Case IH 2300, 2500 Series	7.3
John Deere 60, 70 Series	7.4
John Deere 50 Series	7.5
CAT Lexion 400, 500 (R Series)	7.6
New Holland CR, CX	7.7
AGCO Gleaner R, A Series Challenger 660, 670, 680B Massey 9690, 9790, 9895	7.8

This section includes instructions on setting up, attaching, and detaching the header to the combines listed above.

#### IMPORTANT

Ensure applicable functions (AHHC, Draper Header Option, Hydraulic Center-Link Option, Hydraulic Reel Drive, etc.) are enabled on the combine and combine computer. Failure to do so may result in improper header operation.

#### 7.1 ADAPTER SET-UP

The following sections outline recommended adapter set-up guidelines, depending on your combine and crop. The recommendations cannot cover all conditions. If feeding problems develop with adapter operation, refer to Section 11 TROUBLESHOOTING for detailed information.

#### 7.1.1 CENTER-LINK KIT

Some combine models require shorter center-link components to ensure clearance to the combine cab.

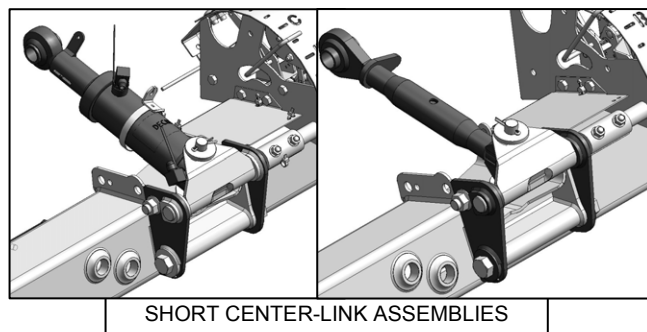

SHORT CENTER-LINK ASSEMBLIES

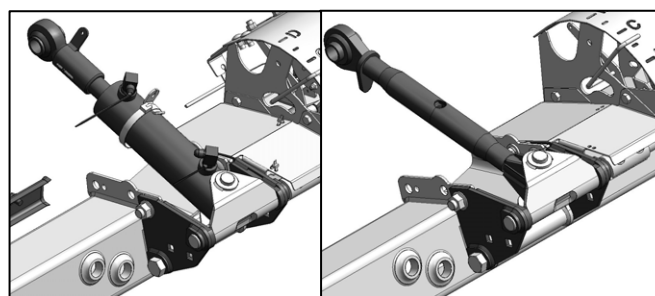

NORMAL CENTER-LINK ASSEMBLIES

To avoid damage to your combine, lift feeder slowly and check clearance between cab and header center-link. If clearance is inadequate, contact your MacDon Dealer to order short center-link components. Installation instructions are included.

The following combine models have been identified for requiring the SHORT center-link components:

- Case IH 5088, 6088, and 7088 without Stone Traps.
- Gleaner R Series.



## SECTION 7. HEADER ATTACHMENT/DETACHMENT

### 7.1.2 FLIGHTING EXTENSIONS

Flighting extension kits may have been supplied with your header to improve feeding in certain crops such as rice. Installation instructions are included with the kits.

They are not recommended in cereal crops.

APPLICABLE COMBINES: All except New Holland CR960, 9060, 970, 9070, and 9080.

If necessary, remove auger flighting extensions as follows:

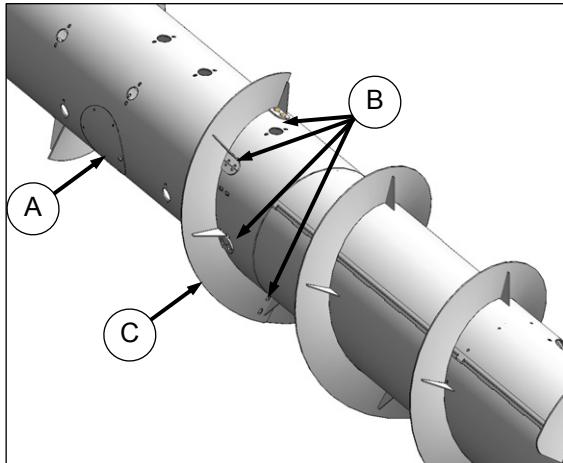

- Remove access cover (A).
- Remove eight bolts (B), washers, and nuts that secure flighting extension (C) to auger and remove extension.
- Repeat for other flighting extension.
- Re-install access cover (A).

### 7.1.3 STRIPPER BARS

Stripper bar kits may have been supplied with your header to improve feeding in certain crops such as rice. Installation instructions are included with the kits.

They are not recommended in cereal crops.

APPLICABLE COMBINES: All except New Holland CR960, 9060, 970, 9070, and 9080.

If necessary, remove auger stripper bars as follows:

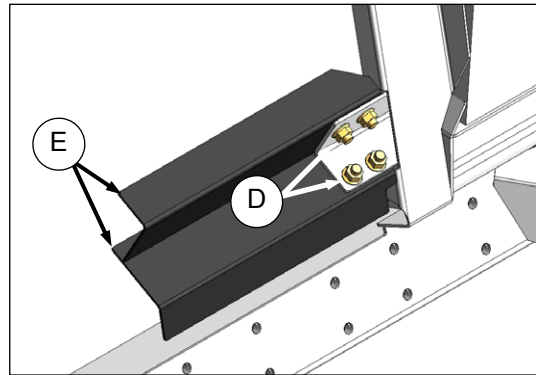

- Remove four bolts (D) and nuts securing bars (E) to adapter frame and remove bars.
- Repeat for opposite set of stripper bars.

## SECTION 7. HEADER ATTACHMENT/DETACHMENT

### 7.1.4 CR FEEDER DEFLECTORS

For New Holland CR 960, 9070, and 9080 combines, feeder kits have been installed on the adapter at the factory to improve feeding into the feeder house. They may also have been installed as an option on older machines. If necessary, they can be removed.

CA20 adapters for the CR Models listed have short feeder kits installed at the factory. Long feeder kits are provided for narrow feeder house combines and are dealer-installed to replace the short feeder kits.

COMBINE MODEL	FEEDER HOUSE SIZE	FEEDER KIT SIZE
CR970, 9070, 9080	Wide	Short - 200 mm
CR960, 9060, 940, 9040	Narrow	Long - 325 mm

If required, replace the feeder deflectors as follows:

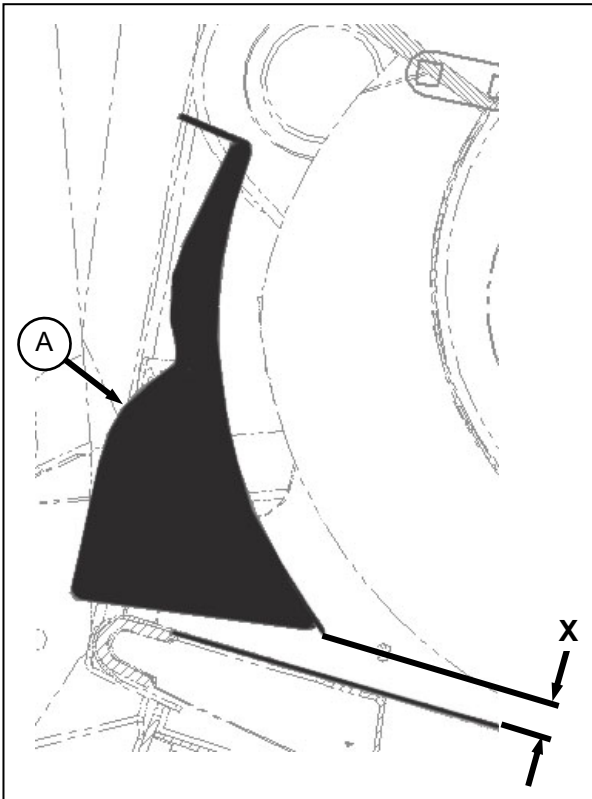

- Determine position of existing deflector (A) by measuring gap "X" between deflector forward edge and pan.

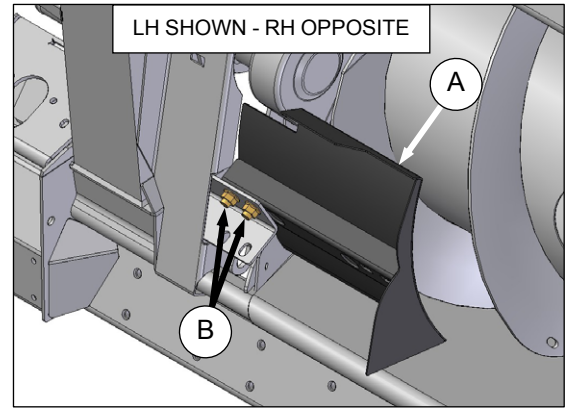

- Remove two bolts (B) and nuts securing deflector (A) to adapter frame and remove deflector.
- Position replacement deflector and secure with bolts (B) and nuts. Maintain dimension "X" from existing deflector for replacement deflector.
- Repeat for opposite deflector.
- After attaching header to combine, extend center-link fully and check gap "X" between deflector and pan. Maintain 7/8 in. (22 mm) +/- 1/8 in. (3 mm).

### 7.1.5 AUGER DRIVE

The adapter auger is chain driven from a sprocket that is mounted on the input shaft from the combine, and which is enclosed in the drive gearbox.

The speed is determined by the combine input shaft, and is matched to each particular combine, so no adjustment is necessary.

However, optional drive sprockets are available to change the auger speed to optimize auger performance. See your MacDon Dealer.

#### NOTE

*For special conditions, 20T, 22T, and 26T sprockets are available to change adapter feed auger speed. Consult with your MacDon Dealer.*

## SECTION 7.2. CASE IH 7010, 8010, 7120, 8120, 88 SERIES

### 7.2 CASE IH 7010, 8010, 7120, 8120, 5088, 6088, 7088



#### 7.2.1 ATTACHMENT

##### IMPORTANT

Some combine models require special center-link components to ensure clearance to the combine cab. To avoid damage to your combine, lift feeder slowly and check clearance between cab and header center-link.

If clearance is inadequate, contact your MacDon Dealer to order special center-link components. Refer to Section 7.1.1 Center-Link Kit.

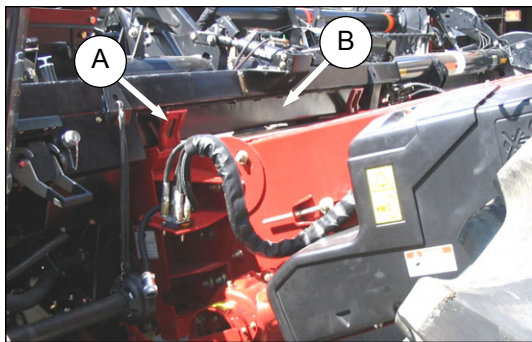

- Slowly drive combine up to adapter until feeder house saddle (A) is directly under the adapter top cross member (B).
- Raise feeder house slightly to lift adapter, ensuring feeder saddle is properly engaged in adapter frame.



##### CAUTION

Stop engine and remove key from ignition before leaving Operator's seat for any reason. A child or even a pet could engage an idling machine.

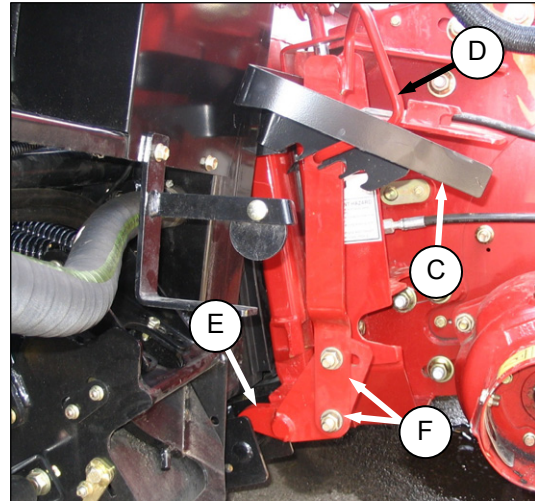

- Lift lever (C) on adapter at left side of feeder house and push handle (D) on combine to engage locks (E) on both sides of the feeder house.
- Push down on lever (C) so that slot in lever engages handle to lock handle in place.
- If lock (E) does not fully engage pin on adapter when (C) and (D) are engaged, loosen bolts (F) and adjust lock as required. Re-tighten bolts.

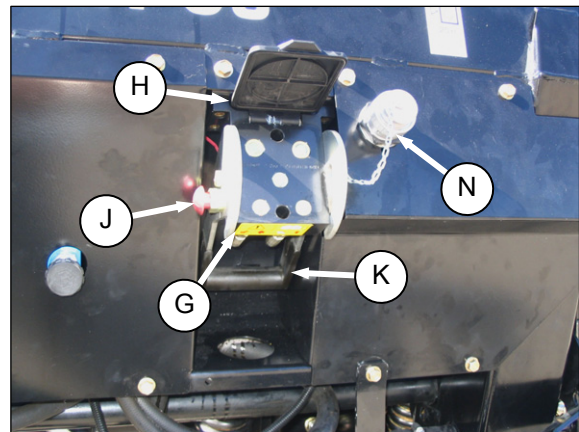

- Connect combine hydraulic quick coupler to receptacle (G) on adapter as follows:
  - Open cover (H).
  - Push in lock button (J) and pull handle (K) to full open position.

*(continued next page)*



## SECTION 7.2. CASE IH 7010, 8010, 7120, 8120, 88 SERIES

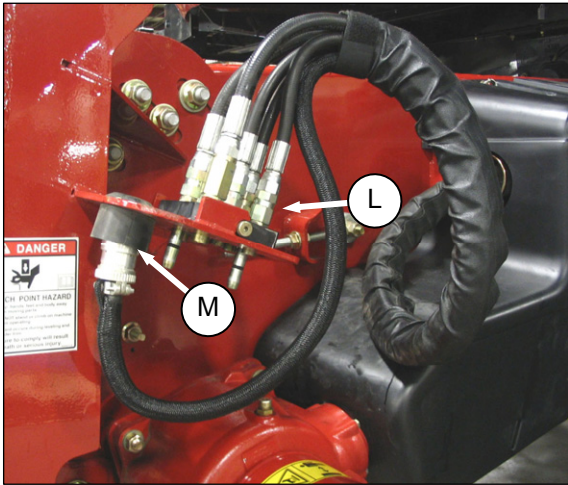

3. Remove coupler (L) from combine and clean mating surfaces.

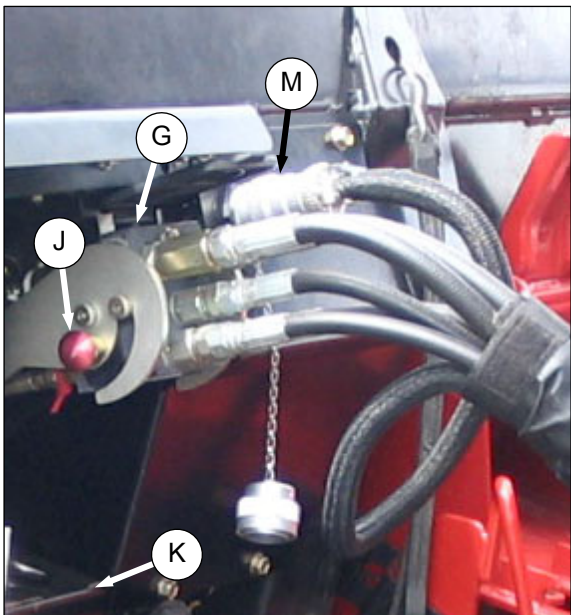

4. Position onto adapter receptacle (G) and push handle (K) to engage coupler pins into receptacle.
  5. Push handle to closed position until lock button (J) snaps out.
- g. Remove cover on adapter electrical receptacle (N). See illustration on previous page.
  - h. Remove electrical connector (M) from storage cup on combine, and route to adapter receptacle.
  - i. Align lugs on connector with slots in receptacle, push connector onto receptacle and turn collar on connector to lock it in place.

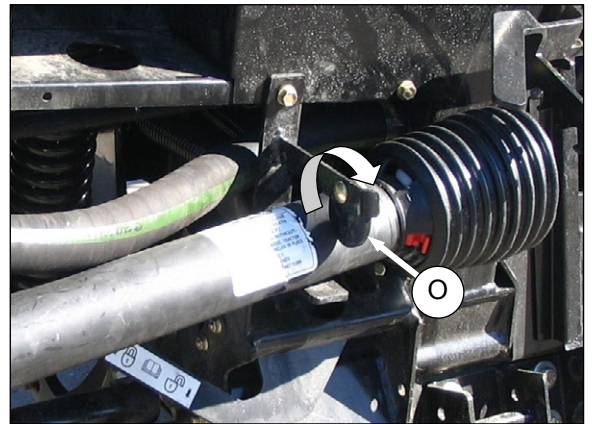

- j. Rotate disc (O) on adapter drive line storage hook and remove drive line from hook.

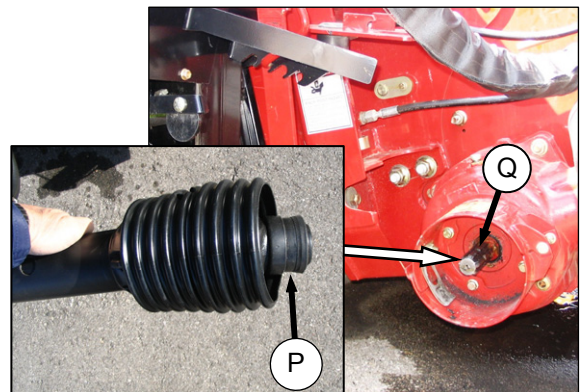

- k. Pull back collar (P) on end of drive line and push onto combine output shaft (Q) until collar locks.

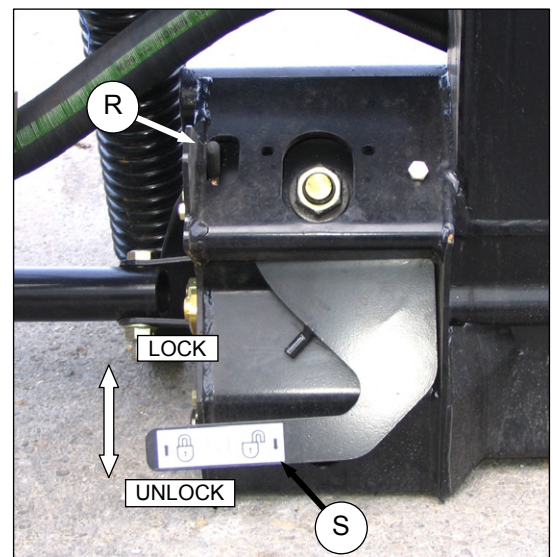

- l. Disengage both adapter float locks by moving latch (R) away from adapter and moving lever (S) at each lock to lowest position.

## SECTION 7.2. CASE IH 7010, 8010, 7120, 8120, 88 SERIES



### IMPORTANT

If stabilizer wheels are installed, set wheels to storage or uppermost working position. Otherwise header may tilt forward so that re-attachment will be difficult. Refer to Section 9.11.2 Cutting Height.

### 7.2.2 DETACHMENT

- Choose a level area. Position header slightly above ground. Stop engine and remove key.



### DANGER

To avoid bodily injury or death from fall of raised machine, always engage lift cylinder stops before going under header for any reason. See your Combine Operator's Manual for instructions for use and storage of header lift cylinder stops.



### CAUTION

Stop engine and remove key from ignition before leaving Operator's seat for any reason. A child or even a pet could engage an idling machine.

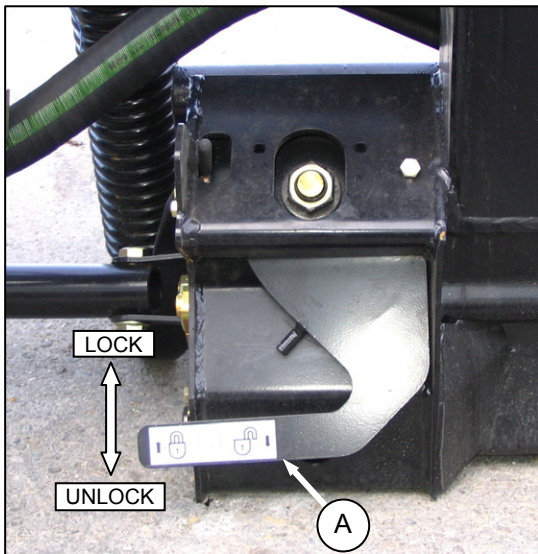

- Engage both adapter float locks by lifting lever (A) at each lock until it latches into the lock position.

### IMPORTANT

If slow speed transport wheels are installed, header may be detached in either transport or field mode. If detaching with wheel in field mode, set wheels to storage or uppermost working position. Refer to Section 9.11.2 Cutting Height.

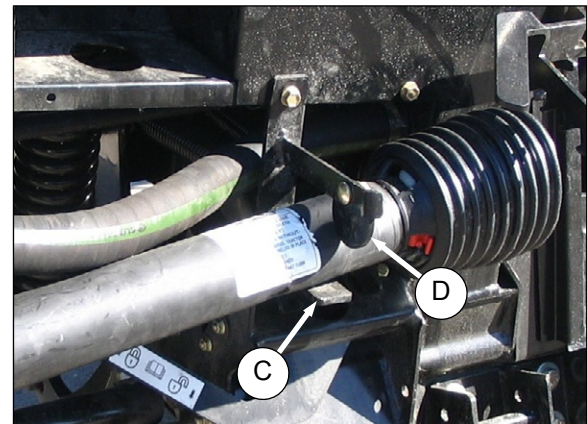
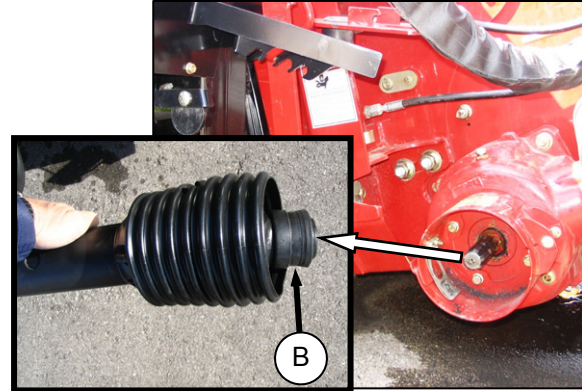

- Disconnect driveshaft (B) from combine and slide driveshaft in hook (C) so that disc (D) drops to secure driveshaft.

*(continued next page)*



## SECTION 7.2. CASE IH 7010, 8010, 7120, 8120, 88 SERIES

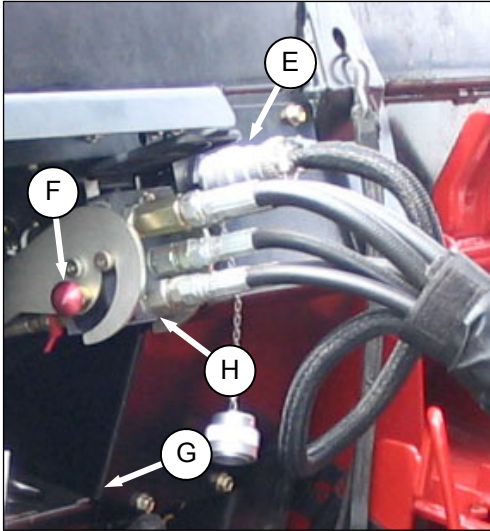

- d. Remove electrical connector (E) and replace cover.
- e. Push in lock button (F) and pull handle (G) to release coupler (H).

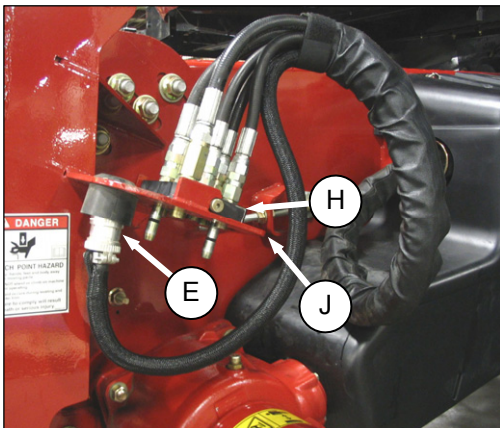

- f. Position coupler (H) onto storage plate (J) on combine. Place electrical connector (E) in storage cup on plate (J).

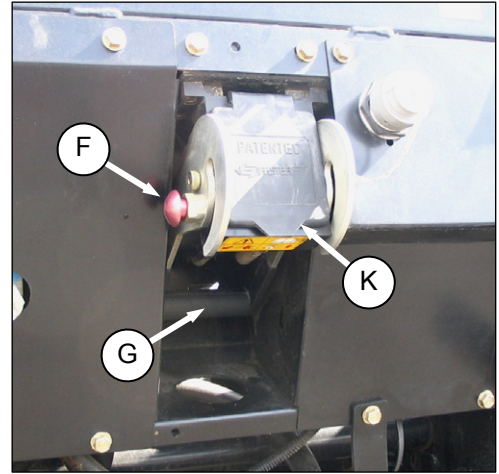

- g. Push handle (G) to closed position until lock button (F) snaps out. Close cover (K).

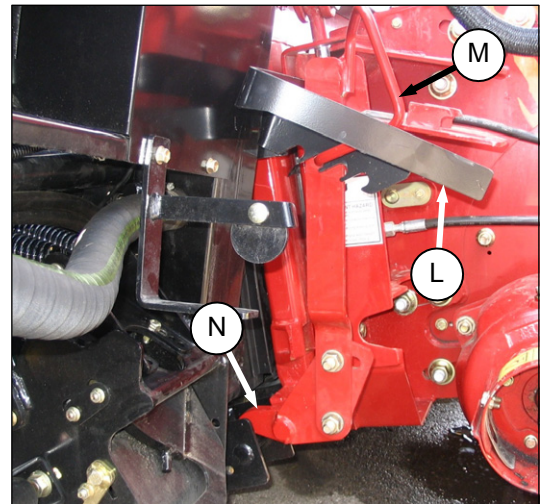

- h. Lift lever (L), pull and lower handle (M) to disengage feeder house/adapter lock (N).
- i. Lower feeder house until it disengages adapter support.
- j. Slowly back combine away from adapter.

## SECTION 7.3. CASE IH 2300, 2500 SERIES

### 7.3 CASE IH 2300, 2500 SERIES



#### 7.3.1 ATTACHMENT

a. Attach adapter to combine as follows:

##### Sliding Pin System

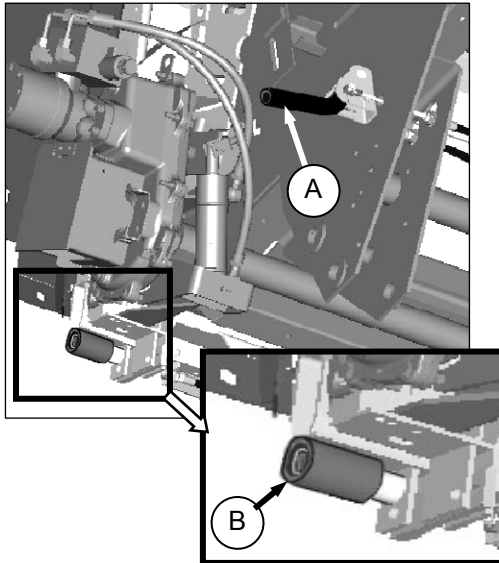

1. Move handle (A) on left side of feeder house to up position to retract both pins (B) at lower corners of feeder house.

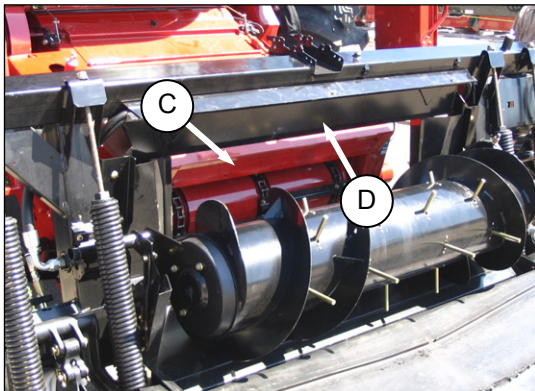

2. Slowly drive combine up to adapter until feeder house saddle (C) is directly under the adapter top cross member (D).
3. Raise feeder house slightly to lift adapter, ensuring feeder saddle is properly engaged in adapter frame.

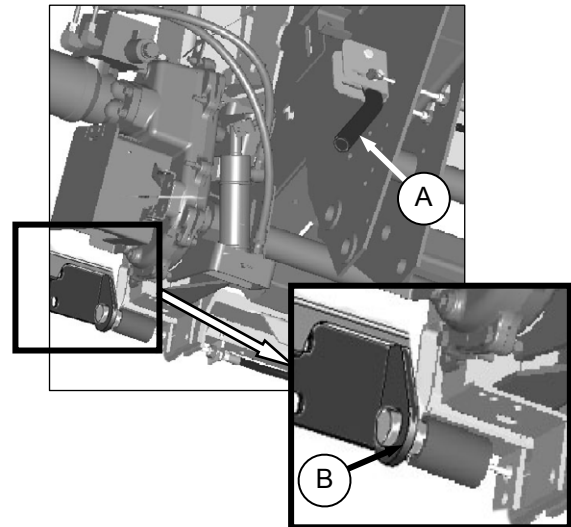

4. Lower handle (A) to engage pins (B) into adapter.
5. Proceed to step c.

##### Latch System



### WARNING

To avoid bodily injury or death from unexpected start-up or fall of raised attachment; stop engine, remove key and engage lift cylinder stop before proceeding with hook-up.

1. Slowly drive combine up to adapter until feeder house saddle (C) is directly under the adapter top cross member (D). See illustration opposite.
2. Raise feeder house fully and engage combine header lift cylinder locks.

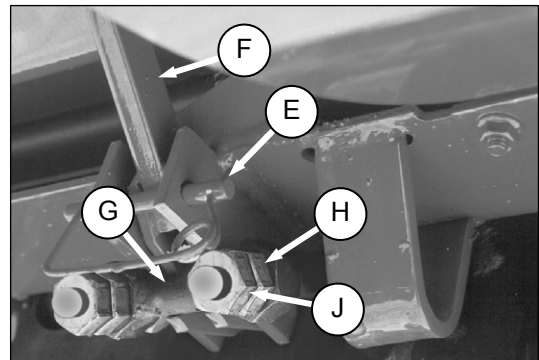

3. Remove pin (E) and lower latch handle (F) (one on each side of feeder house underside) to hook latch (G).
4. Lift handle to overcenter position to lock. Requires 40 - 50 lbf (180 - 220 N) to move handle overcenter. Adjust nuts (H) on U-bolts to vary force required on handle.

*(continued next page)*



## SECTION 7.3. CASE IH 2300, 2500 SERIES

5. Tighten jam-nuts (J) when force is correct.
  6. Install pin (E) as shown to secure latch handle in locked position.
- b. Remove combine header lift cylinder locks and lower header to ground.
- c. Connect combine hydraulics to adapter as follows:

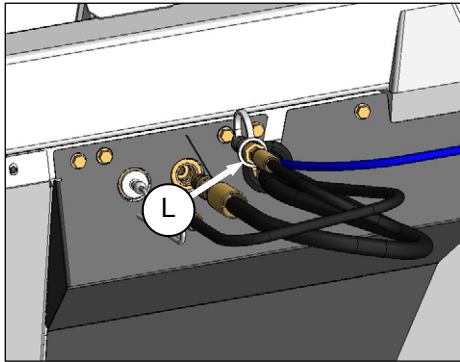
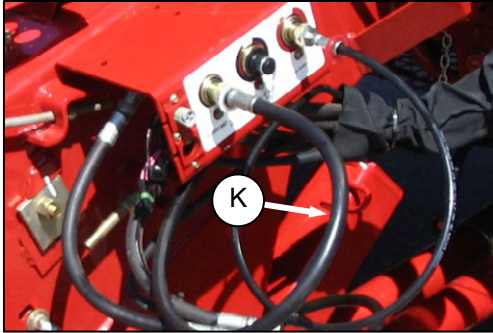

1. Disconnect reel drive hoses (K) and (L) (white discs) from combine and adapter receptacles.

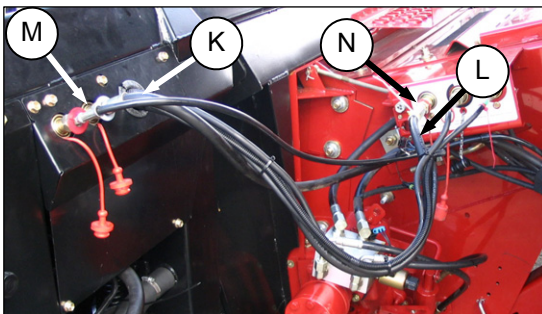

2. Connect hose (K) from combine to adapter coupler (M).
3. Connect hose (L) from the adapter to the combine coupler (N).

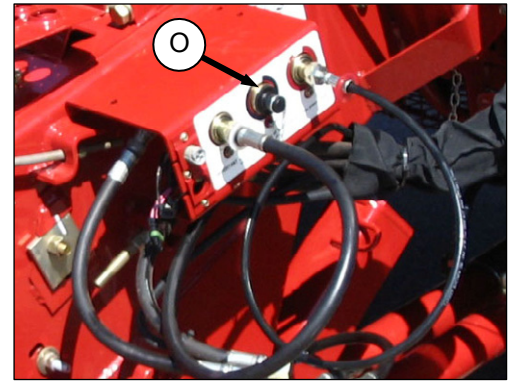

4. Remove plug from reel lift coupler (O) (black disc) on combine.

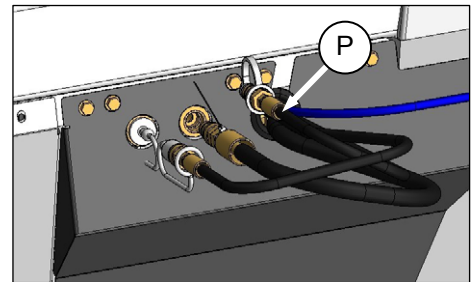

5. Remove red dust cap from reel lift hose (P) on adapter and connect hose to combine coupler (O).

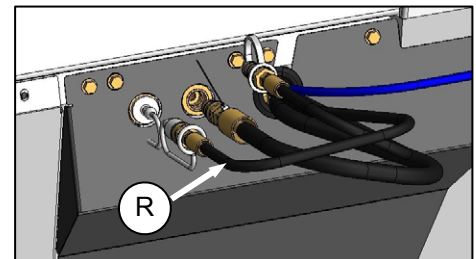
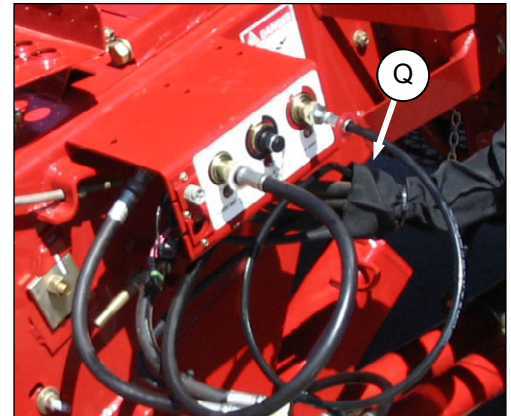

6. Disconnect reel fore-aft hoses (Q) and (R) (red discs) from combine and adapter receptacles.

*(continued next page)*

## SECTION 7.3. CASE IH 2300, 2500 SERIES

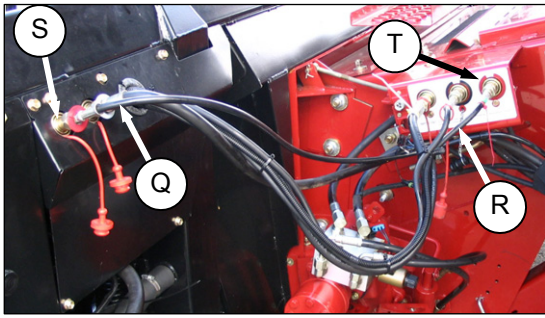

7. Connect hose (Q) from combine to adapter coupler (S).
8. Connect hose (R) from the adapter to the combine coupler (T).

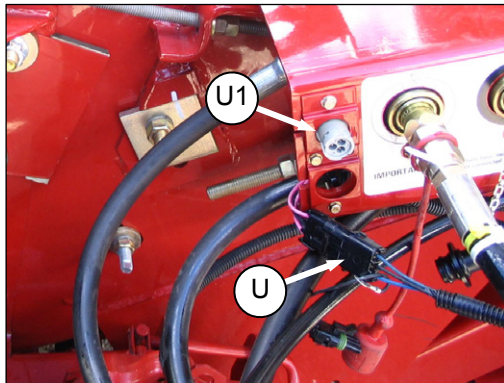

- d. Connect adapter electrical harness (U) to combine electrical connector, and if applicable connect AHHC wire harness at U1.

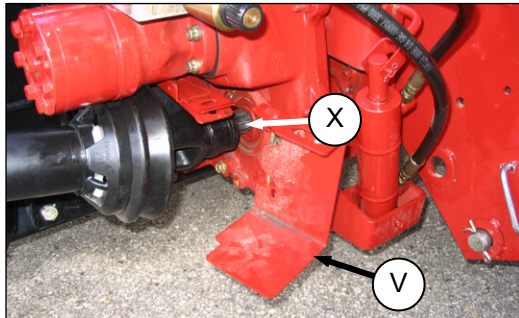

- e. Open guard (V) at combine output shaft.

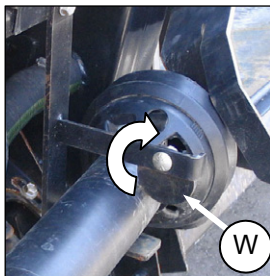

- f. Rotate disc (W) on adapter driveline storage hook and remove driveline from hook.

- g. Pull back collar on end of driveline and push onto combine output shaft (X) until collar locks. Close guard (V).

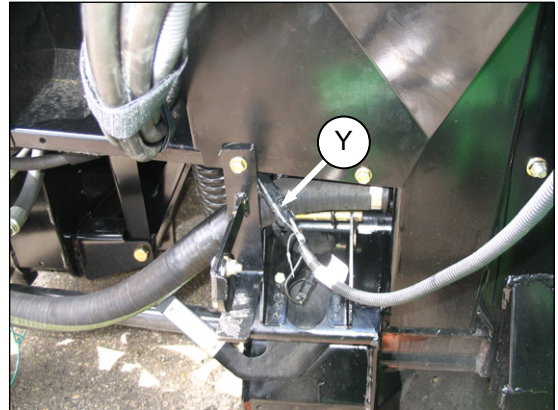

- h. If adapter is equipped with reel fore-aft/header tilt selector, connect harness (Y) to combine.

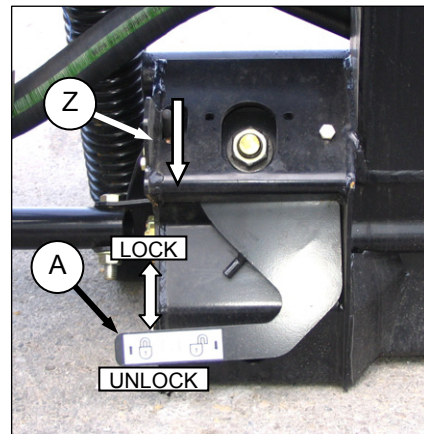

- i. Disengage both adapter float locks by moving latch (Z) away from adapter and moving lever (A) at each lock to lowest position.



## SECTION 7.3. CASE IH 2300, 2500 SERIES



### 7.3.2 DETACHMENT

- a. Choose a level area. Position header slightly above ground. Stop engine and remove key.



#### DANGER

To avoid bodily injury or death from fall of raised machine, always engage lift cylinder stops before going under header for any reason. See your Combine Operator's Manual for instructions for use and storage of header lift cylinder stops.



#### CAUTION

Stop engine and remove key from ignition before leaving Operator's seat for any reason. A child or even a pet could engage an idling machine.

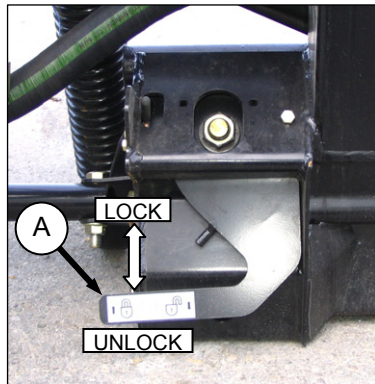

- b. Engage both adapter float locks by lifting lever (A) at each lock until it latches into the lock position.

#### IMPORTANT

If slow speed transport wheels are installed, header may be detached in either transport or field mode. If detaching with wheel in field mode, set wheels to storage or uppermost working position. Otherwise header may tilt forward so that re-attachment will be difficult. Refer to Section 9.11.2 Cutting Height.

#### IMPORTANT

If stabilizer wheels are installed, set wheels to storage or uppermost working position. Otherwise header may tilt forward so that re-attachment will be difficult. Refer to Section 9.11.2 Cutting Height.

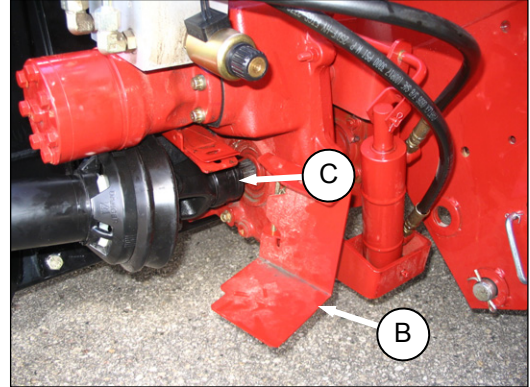

- c. Open guard (B).  
d. Pull back collar (C) on driveline and pull driveline off combine shaft. Close guard (B).

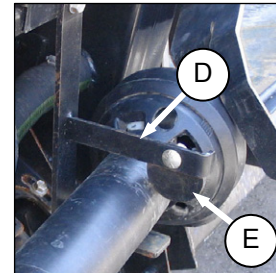

- e. Slide driveline in hook (D) so that disc (E) drops to secure driveshaft.

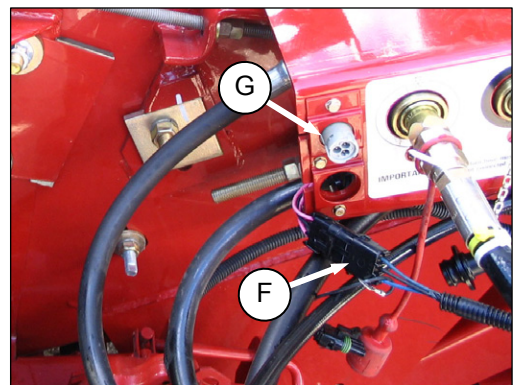

- f. Disconnect wiring harness (F) and attach covers on each plug.  
g. If applicable, unplug AHHC wiring harness from connector (G).

*(continued next page)*

## SECTION 7.3. CASE IH 2300, 2500 SERIES

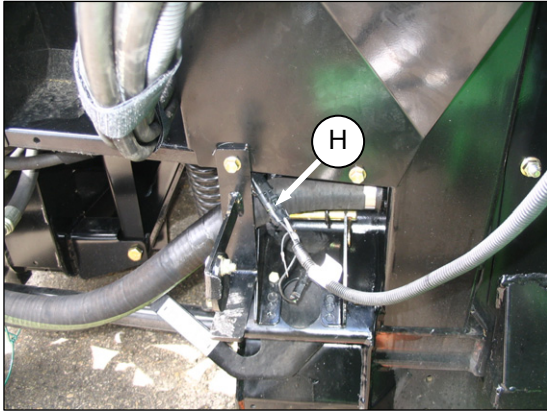

- h. If adapter is equipped with reel fore-aft/header tilt selector, disconnect harness (H) and store on combine.
- i. Disconnect hydraulics as follows:

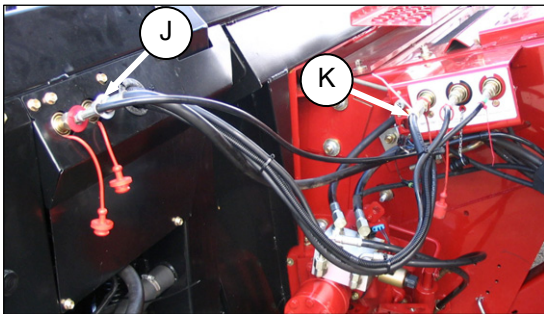

1. Disconnect reel drive hoses (J) and (K) (white discs) from adapter and combine receptacles.

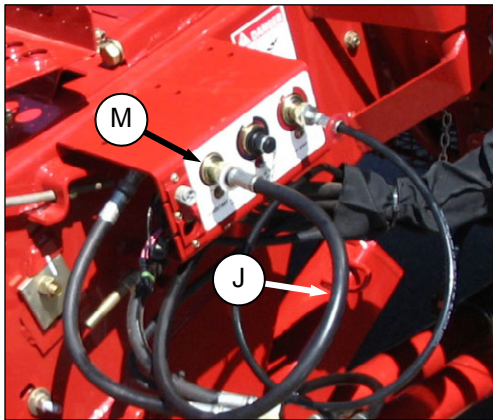

2. Connect hose (J) from combine to combine coupler (M).

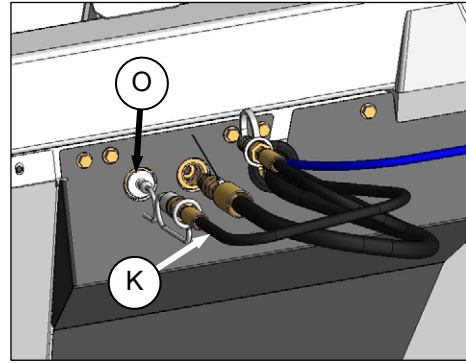

3. Connect hose (K) from the adapter to the adapter coupler (O).

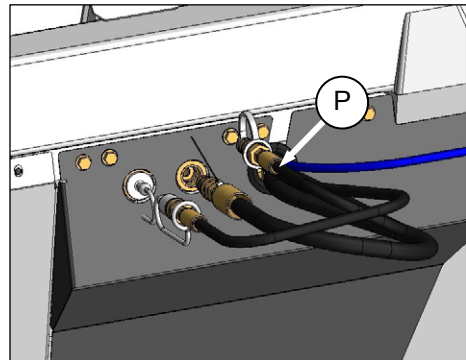
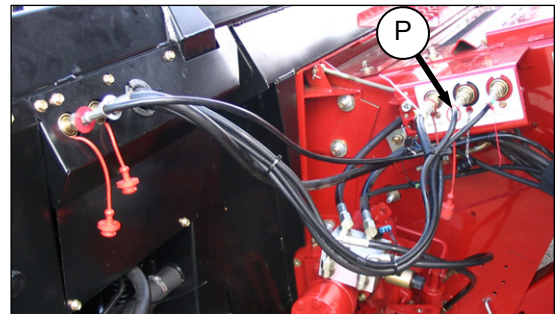

4. Disconnect reel lift hose (P) (black disc) on combine and attach red dust cap. Store hose on adapter.



### CAUTION

Do not connect reel lift hose and reel fore-aft hose to couplers on adapter. Doing so may cause reel to inadvertently shift during transport.

*(continued next page)*



## SECTION 7.3. CASE IH 2300, 2500 SERIES

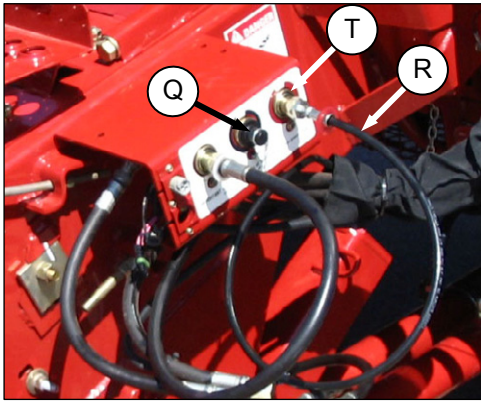

5. Re-install plug on combine coupler (Q).

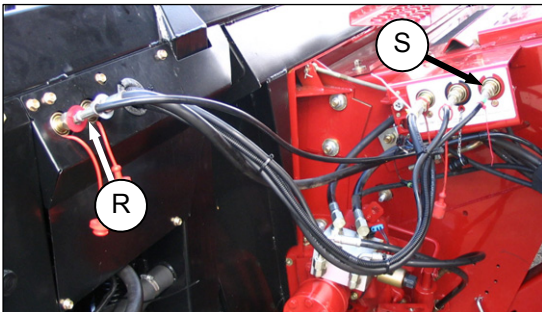

6. Disconnect reel fore-aft hoses (R) and (S) (red discs) from adapter and combine receptacles.
7. Connect hose (R) from combine to combine coupler (T).

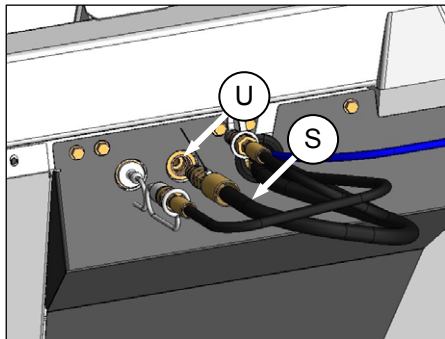

8. Connect hose (S) from the adapter to the adapter coupler (U).



### WARNING

To avoid bodily injury or death from unexpected start-up or fall of raised attachment; stop engine, remove key and engage lift cylinder stop before proceeding with hook-up.

- j. Disengage adapter from combine with one of the following two methods depending on combine model.

#### Latch System

1. Raise feeder house fully and engage combine header lift cylinder locks.

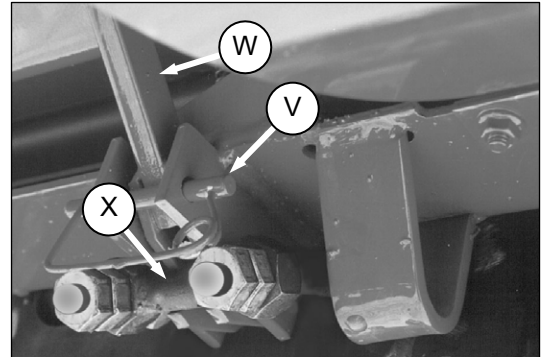

2. Remove pin (V) and lower latch handle (W) (one on each side of feeder house) to disengage latch (X).
3. Raise latch handle to storage position and secure with pin (V).
4. Proceed to step k.

#### Sliding Pin System

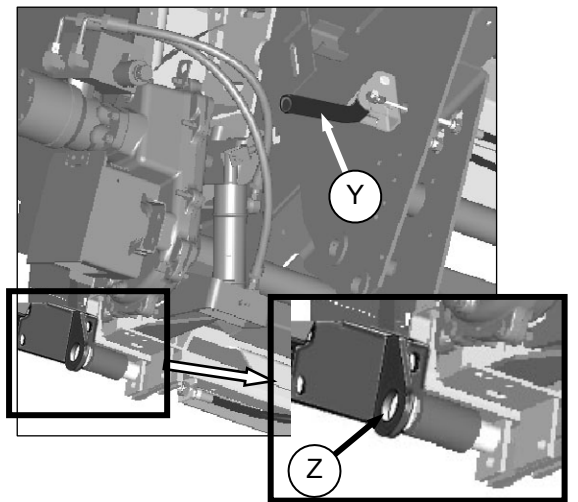

1. Raise handle (Y) on left side of feeder house to retract pins (Z).
- k. Lower feeder house until it disengages adapter support.
- l. Slowly back combine away from adapter.

## SECTION 7.4. JOHN DEERE 60, 70 SERIES

### 7.4 JOHN DEERE 60, 70 SERIES



Contour Master, Level Land

#### 7.4.1 ATTACHMENT

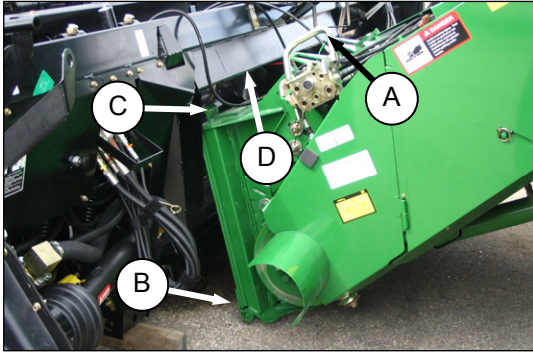

- Push handle (A) on combine coupler toward feeder house to retract pins (B) at bottom corners of feeder house.
- Slowly drive combine up to adapter until feeder house saddle (C) is directly under the adapter top cross member (D).
- Raise feeder house to lift adapter, ensuring feeder saddle is properly engaged in adapter frame.
- Raise or lower header until slightly off the ground.



### CAUTION

Stop engine and remove key from ignition before leaving Operator's seat for any reason. A child or even a pet could engage an idling machine.

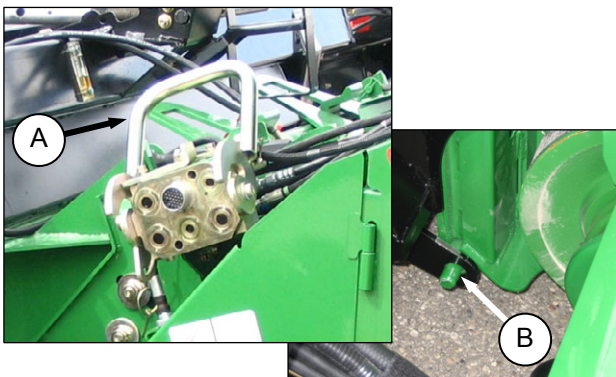

- Pull handle (A) to engage pins (B) in adapter.

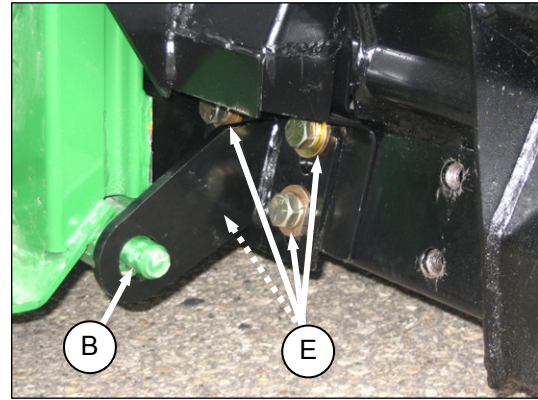

- Check that bolts (E) on adapter brackets are tight.
- If pins (B) do not fully engage adapter brackets, loosen bolts (E) and adjust bracket as required. Re-tighten bolts.
- Remove blocks from under cutterbar.
- Start engine and lower header.

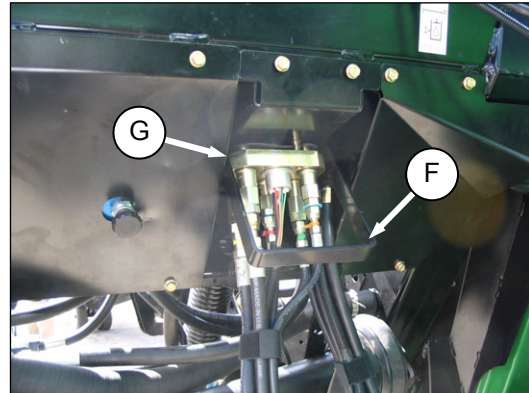

- Pull handle (F) on adapter to release coupler (G) from storage position. Remove coupler and push handle back into adapter to store.
- Attach coupler (G) to combine as follows:

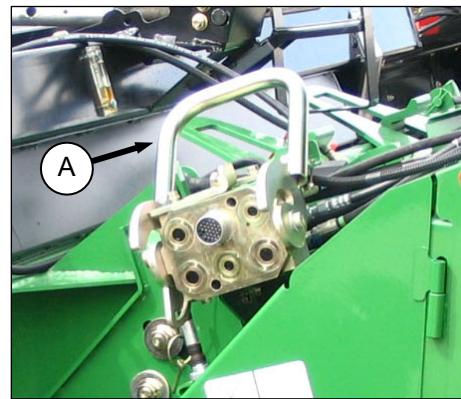

- Handle (A) should be in the nearly up position. Clean receptacle.

(continued next page)



## SECTION 7.4. JOHN DEERE 60, 70 SERIES

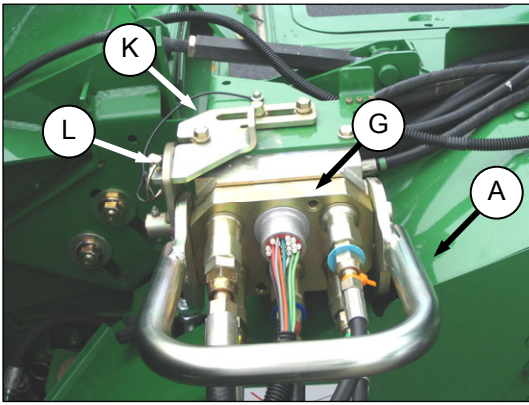

2. Locate coupler (G) onto receptacle and pull handle (A) so that lugs on coupler are engaged into handle.
3. Pull handle to full horizontal position as shown.
4. Slide latch (K) to lock handle in position and secure with lynch pin (L).

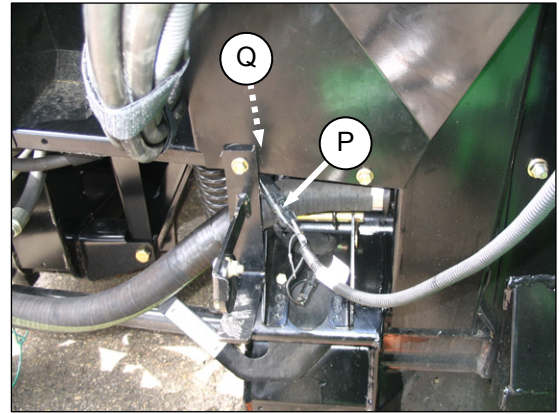

- n. If adapter is equipped with reel fore-aft/header tilt selector, connect harness (P) to combine.

### NOTE

*Connector (P) may need to be retrieved from hydraulics compartment access hole (Q).*

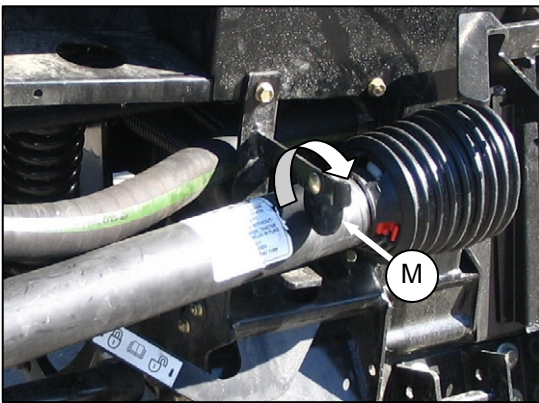

- l. Rotate disc (M) on adapter driveline storage hook and remove driveline from hook.

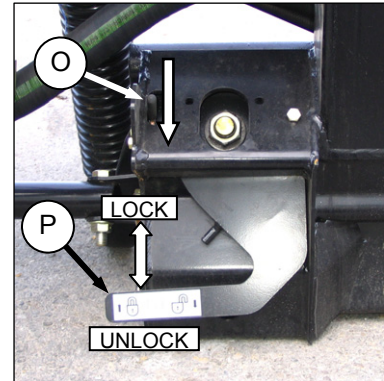

- o. Disengage both adapter float locks by moving latch (O) away from adapter and moving lever (P) at each lock to lowest position.

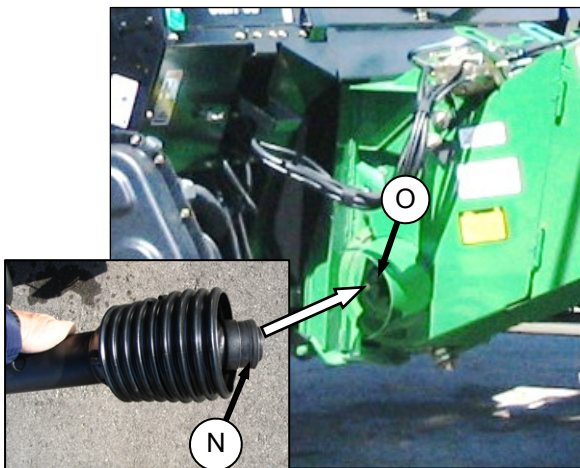

- m. Pull back collar (N) on end of driveline and push onto combine output shaft (O) until collar locks.



## SECTION 7.4. JOHN DEERE 60, 70 SERIES



### IMPORTANT

If stabilizer wheels are installed, set wheels to storage or uppermost working position. Otherwise header may tilt forward so that re-attachment will be difficult. Refer to Section 9.11.2 Cutting Height.

### 7.4.2 DETACHMENT

- a. Choose a level area. Position header slightly above ground. Stop engine and remove key.



### DANGER

To avoid bodily injury or death from fall of raised machine, always engage lift cylinder stops before going under header for any reason. See your Combine Operator's Manual for instructions for use and storage of header lift cylinder stops.



### CAUTION

Stop engine and remove key from ignition before leaving Operator's seat for any reason. A child or even a pet could engage an idling machine.

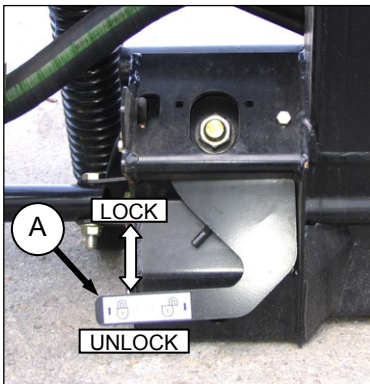

- b. Engage both adapter float locks by lifting lever (A) at each lock until it latches into the lock position.

### IMPORTANT

If slow speed transport wheels are installed, header may be detached in either transport or field mode. If detaching with wheel in field mode, set wheels to storage or uppermost working position. Otherwise header may tilt forward so that re-attachment will be difficult. Refer to Section 9.11.2 Cutting Height.

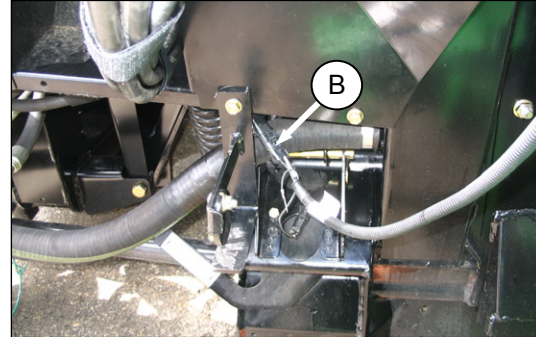

- c. If adapter is equipped with reel fore-aft/header tilt selector, disconnect harness (B) and store on combine.

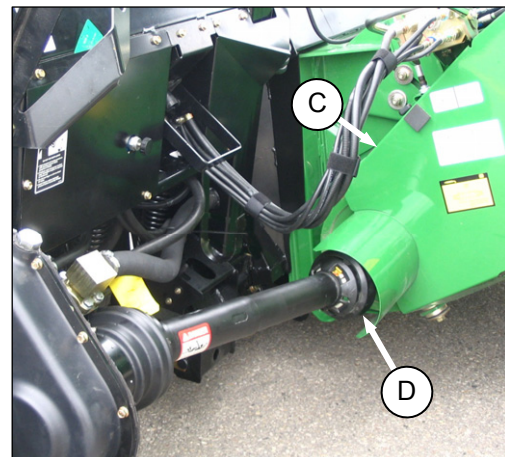

- d. Open shield (C) on combine. Pull back collar on driveline and pull driveline (D) off combine output shaft.

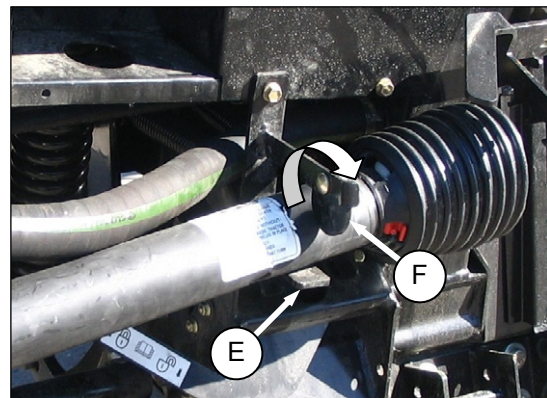

- e. Slide driveshaft in hook (E) so that disc (F) drops to secure driveshaft.

(continued next page)

## SECTION 7.4. JOHN DEERE 60, 70 SERIES

- f. Disconnect hydraulic/electrical coupler (G) from combine as follows:

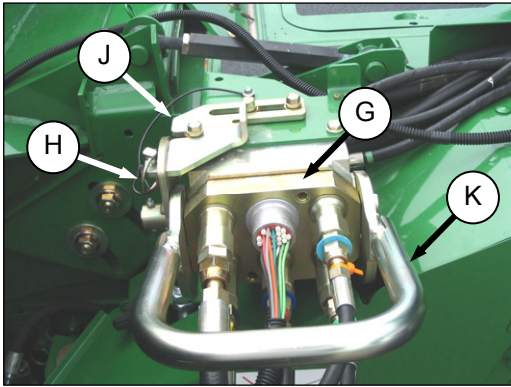

1. Remove lynch pin (H) and slide lock (J) to release handle (K).
2. Lift handle (K) to full vertical position to release coupler (G) from combine.

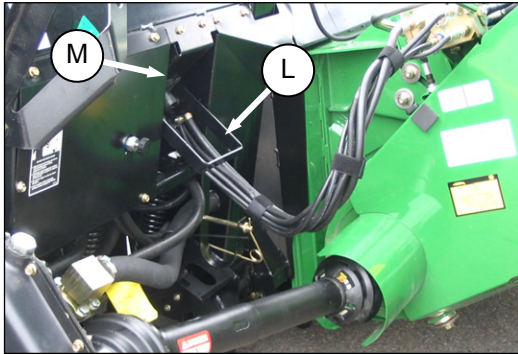

3. Lift handle (L) on adapter, position coupler in adapter at (M), and lower handle (L) to lock coupler.

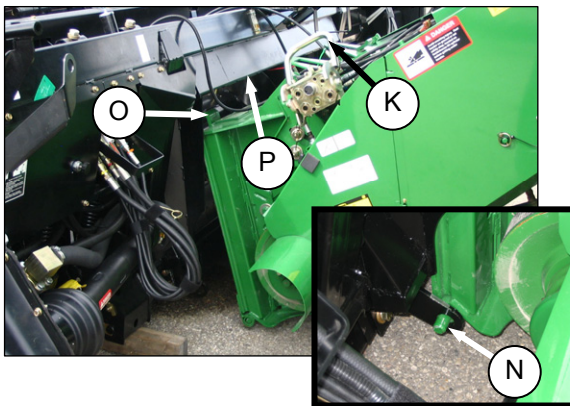

- g. Push handle (K) toward feeder house to disengage feeder house pin (N) from adapter.
- h. Lower feeder house until saddle (O) disengages and clears adapter support (P).
- i. Slowly back combine away from adapter.



## SECTION 7.5. JOHN DEERE 50 SERIES

### 7.5 JOHN DEERE 50 SERIES

Contour Master, Level Land



#### 7.5.1 ATTACHMENT

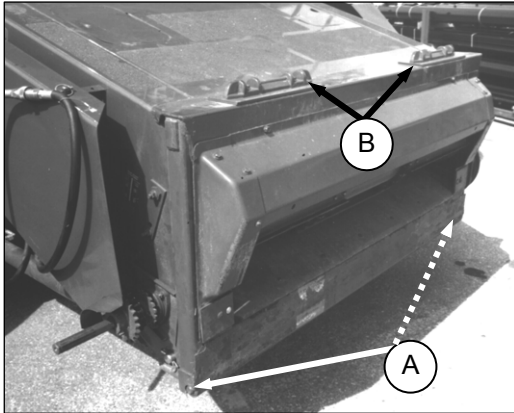

- a. Retract pins (A) at bottom corners of feeder house. See Combine Operator's manual.

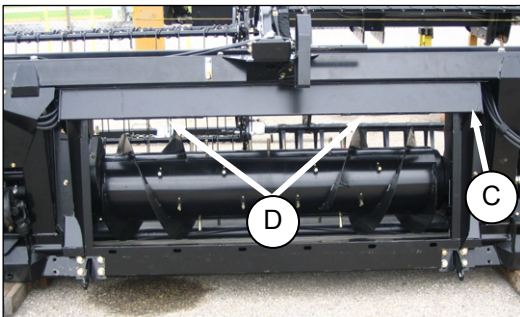

- b. Slowly drive combine up to adapter until feeder house lift lugs (B) are directly under the adapter top cross member (C).  
 c. Raise feeder house slightly to lift adapter, ensuring lift lugs (B) are properly engaged in adapter frame sockets (D).



#### CAUTION

Stop engine and remove key from ignition before leaving Operator's seat for any reason. A child or even a pet could engage an idling machine.

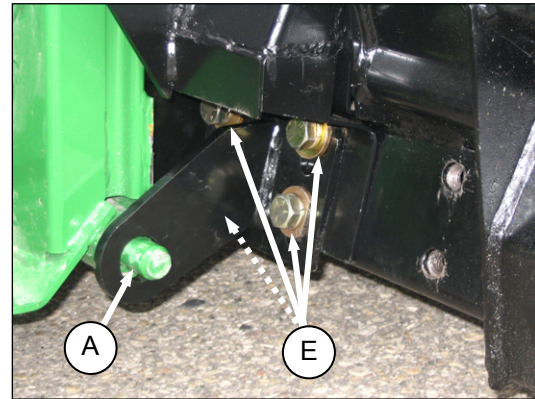

- d. Engage pins (A) in adapter.  
 e. Check that bolts (E) on adapter brackets are tight.  
 f. If pins (A) do not fully engage adapter brackets, loosen bolts (E) and adjust bracket as required. Re-tighten bolts.  
 g. At left side of combine feeder house, retrieve reel aft hose, reel lift hose and electrical harness.

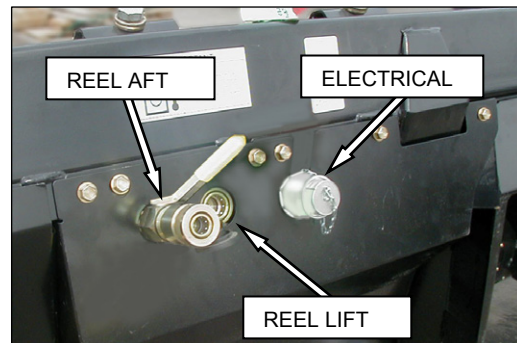

- h. Clean couplers and attach as shown above.  
 i. At right side of feeder house, disconnect reel drive hoses and retrieve reel fore hose.

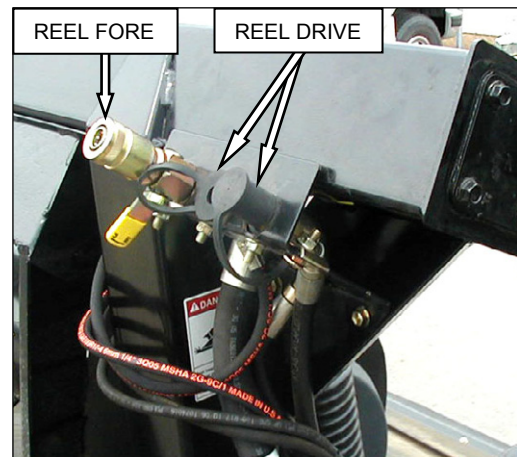

- j. Clean couplers and attach as shown above.

(continued next page)

## SECTION 7.5. JOHN DEERE 50 SERIES

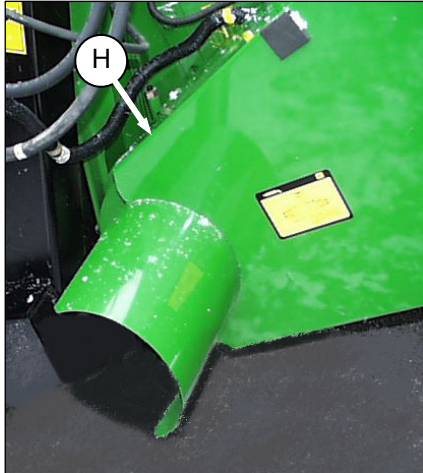

k. Open shield (H) on combine.

n. Close driveshield (H) on combine.

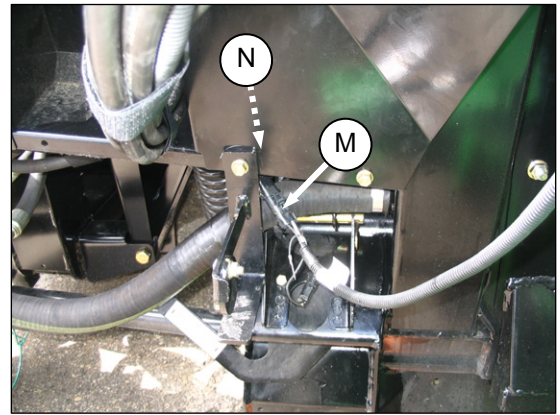

o. If adapter is equipped with reel fore-aft/header tilt selector, connect harness (M) to combine.

### NOTE

*Connector (M) may need to be retrieved from hydraulics compartment access hole (N).*

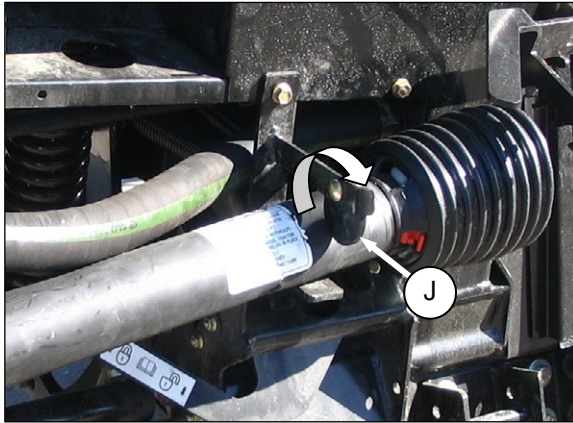

l. Rotate disc (J) on adapter driveline storage hook and remove driveline from hook.

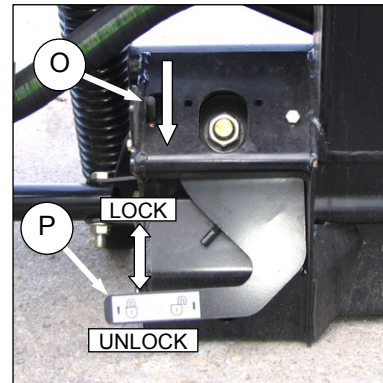

p. Disengage both adapter float locks by moving latch (O) away from adapter and moving lever (P) at each lock to lowest position.

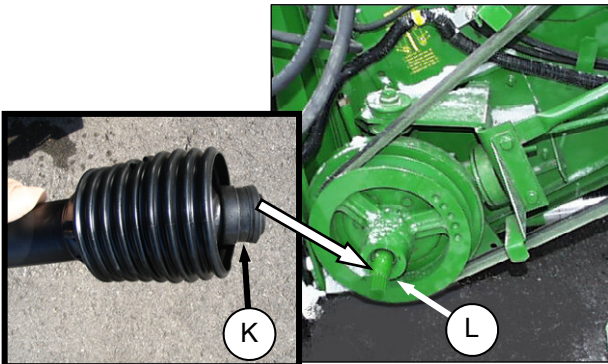

m. Pull back collar (K) on end of driveline and push onto combine output shaft (L) until collar locks.



## SECTION 7.5. JOHN DEERE 50 SERIES



### IMPORTANT

If stabilizer wheels are installed, set wheels to storage or uppermost working position. Otherwise header may tilt forward so that re-attachment will be difficult. Refer to Section 9.11.2 Cutting Height.

### 7.5.2 DETACHMENT

- Choose a level area. Position header slightly off the ground. Stop engine and remove key.



### DANGER

To avoid bodily injury or death from fall of raised machine, always engage lift cylinder stops before going under header for any reason. See your Combine Operator's Manual for instructions for use and storage of header lift cylinder stops.



### CAUTION

Stop engine and remove key from ignition before leaving Operator's seat for any reason. A child or even a pet could engage an idling machine.

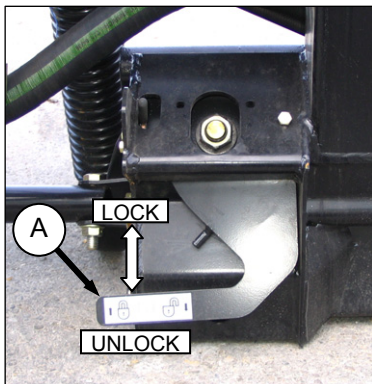

- Engage both adapter float locks by lifting lever (A) at each lock until it latches into the lock position.

### IMPORTANT

If slow speed transport wheels are installed, header may be detached in either transport or field mode. If detaching with wheel in field mode, set wheels to storage or uppermost working position. Otherwise header may tilt forward so that re-attachment will be difficult. Refer to Section 9.11.2 Cutting Height.

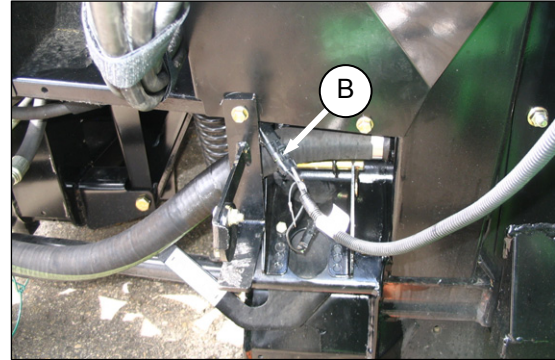

- If adapter is equipped with reel fore-aft/header tilt selector, disconnect harness (B) and store on combine.

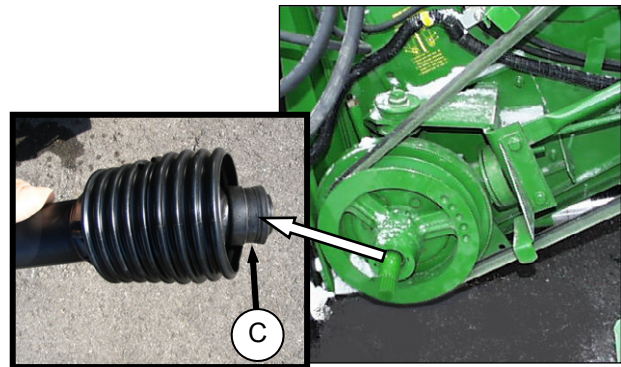

- Open shield on combine. Pull back collar (C) on driveline and pull driveline off combine output shaft.

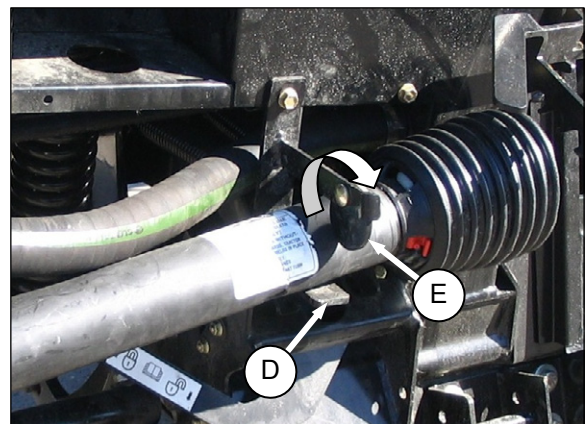

- Slide driveshaft in hook (D) so that disc (E) drops to secure driveshaft.

(continued next page)

## SECTION 7.5. JOHN DEERE 50 SERIES

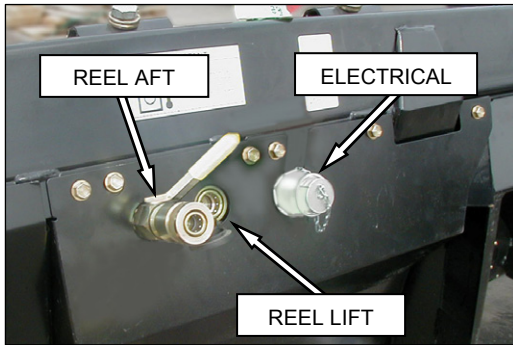

- f. At left side of adapter, close valve on reel aft line. Disconnect both hydraulic lines and electrical cable. Attach caps and plugs and store on combine.

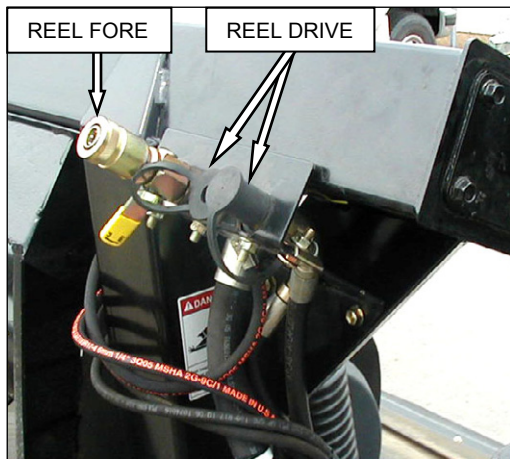

- g. At right side of adapter disconnect the three hydraulic lines. Attach caps and plugs and store hoses on combine.

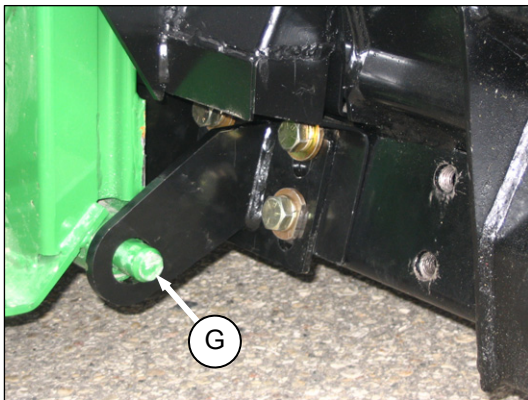

- h. Retract header attachment pins (G) to disengage adapter brackets.

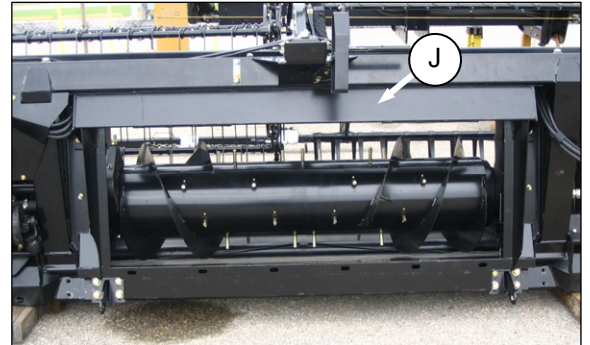
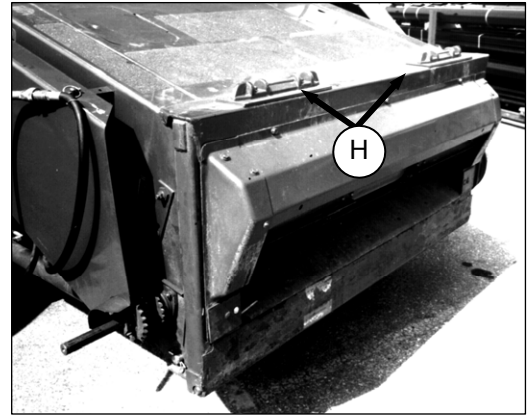

- i. Lower feeder house until saddle (H) disengages and clears adapter support (J).
- j. Slowly back combine away from adapter.

## SECTION 7.6. CAT LEXION 400, 500 SERIES

### 7.6 CAT LEXION 400, 500 SERIES



#### 7.6.1 ATTACHMENT

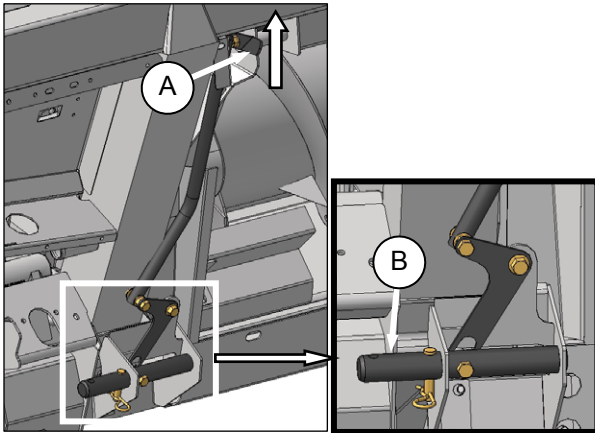

- Handle (A) on the CA20 adapter should be in raised position and pins (B) at bottom corners of adapter retracted.
- Slowly drive combine up to adapter until feeder house is directly under the adapter top cross member.

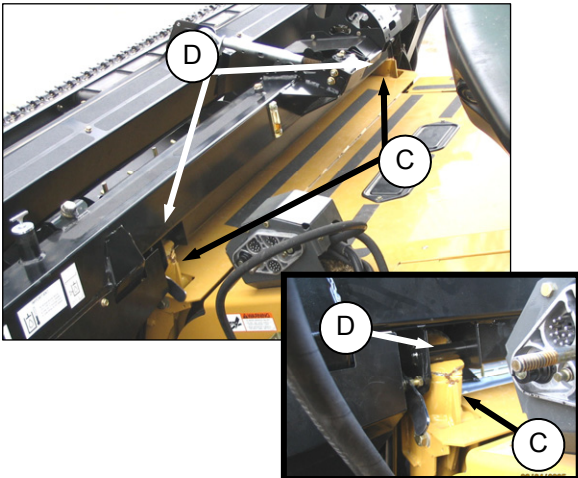

- Raise feeder house to lift adapter, ensuring feeder house posts (C) are properly engaged in adapter frame (D).
- Position header slightly off the ground.



### CAUTION

Stop engine and remove key from ignition before leaving Operator's seat for any reason. A child or even a pet could engage an idling machine.

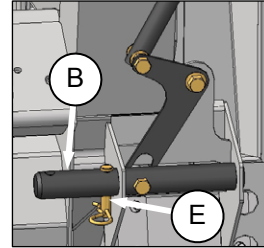

- Remove locking pin (E) from adapter pin (B).

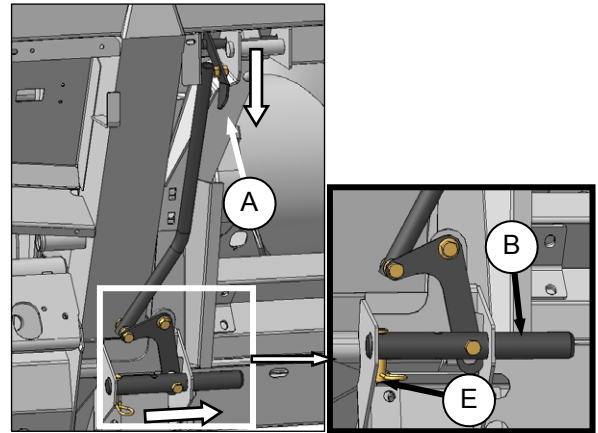

- Lower handle (A) to engage adapter pins into feeder house. Re-insert locking pin (E) and secure with hairpin.

*(continued next page)*



## SECTION 7.6. CAT LEXION 400, 500 SERIES

g. Connect hydraulic hoses as follows:

### Lexion 400 Attachment

#### Lexion 500 Attachment

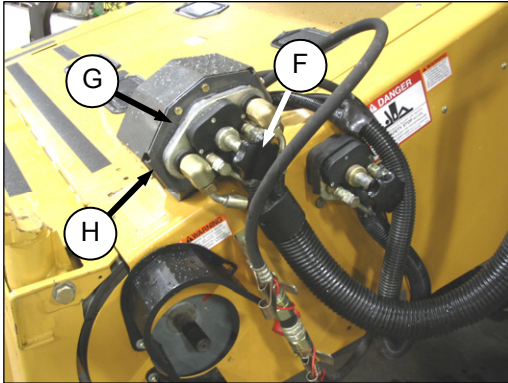

1. Unscrew knob (F) on combine coupler (G) to release coupler from combine receptacle (H).

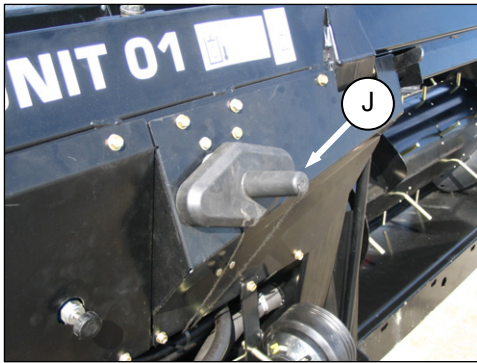

2. Remove cover (J) from adapter receptacle.

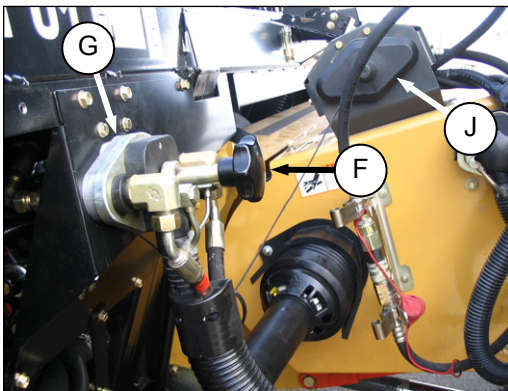

3. Clean mating surface of coupler (G) and locate onto adapter receptacle. Turn knob (F) to secure coupler to receptacle.
4. Place cover (J) on combine receptacle.
5. Proceed to step h.

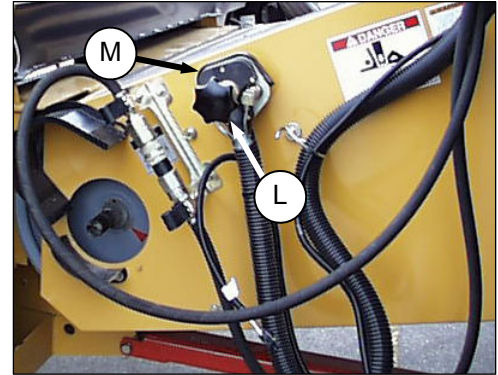

1. Unscrew knob (L) on combine coupler (M) to release coupler from combine receptacle.

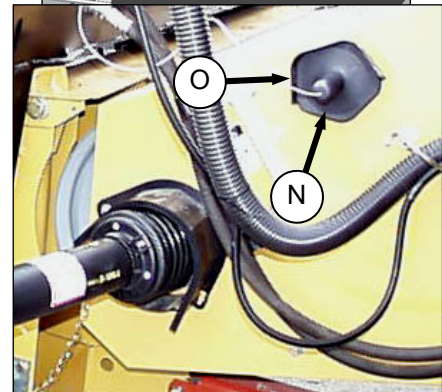
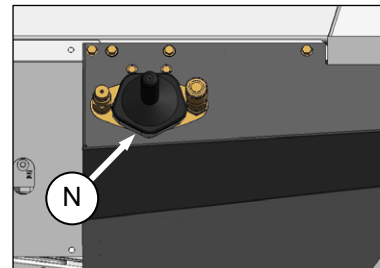

2. Remove cover (N) from adapter receptacle and place on combine receptacle (O).

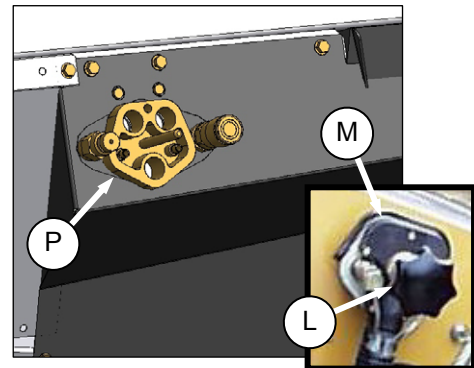

3. Locate combine coupler (M) onto adapter receptacle (P) and turn knob (L) to secure coupler to receptacle.

*(continued next page)*



## SECTION 7.6. CAT LEXION 400, 500 SERIES

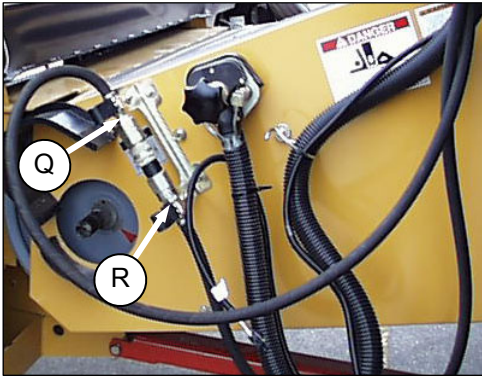

4. Disconnect hoses (Q) and (R) on combine at couplers.

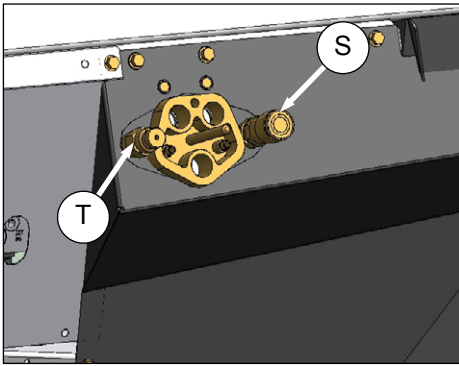

5. Clean couplers (S) and (T) on adapter.
6. Connect hose (R) to coupler (S) on adapter.
7. Connect hose (Q) to coupler (T) on adapter.

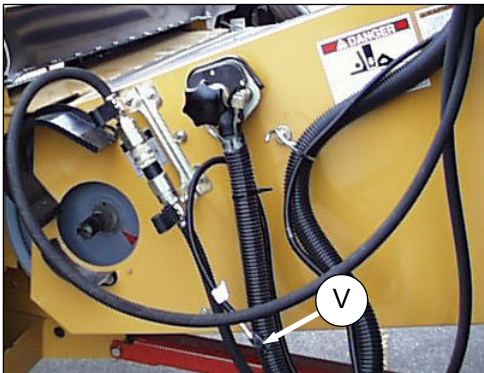
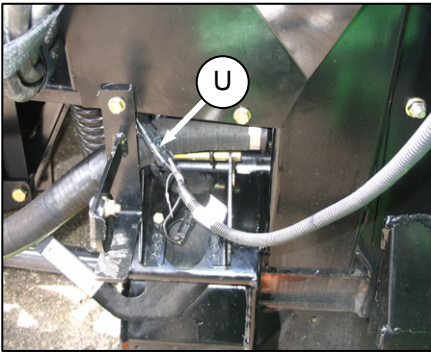

- h. If adapter is equipped with reel fore-aft/header tilt selector, connect harness (U) to combine harness (V).

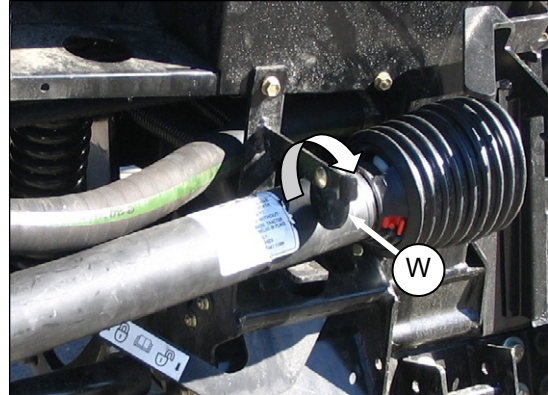

- i. Rotate disc (W) on adapter driveline storage hook and remove driveline from hook.

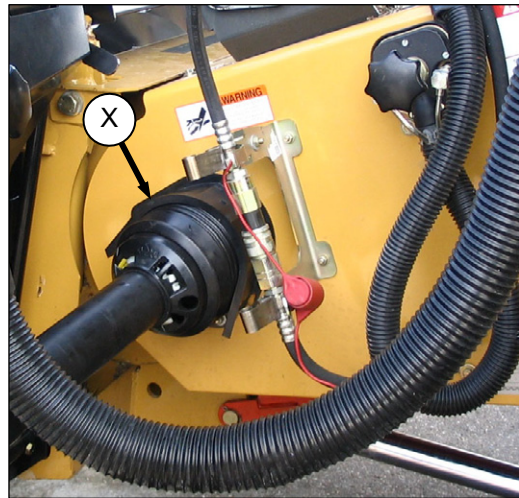

- j. Attach driveline to combine output shaft (X).

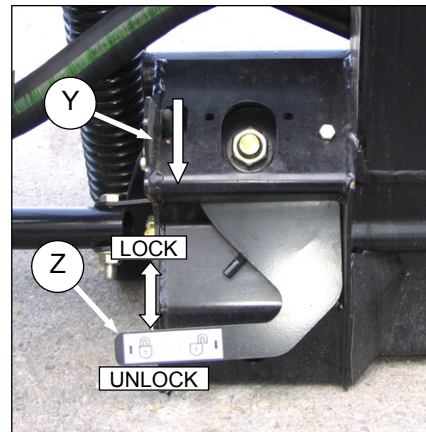

- k. Disengage both adapter float locks by moving latch (Y) away from adapter and moving lever (Z) at each lock to lowest position.

## SECTION 7.6. CAT LEXION 400, 500 SERIES



### 7.6.2 DETACHMENT

- a. Choose a level area. Position header slightly off the ground. Stop engine and remove key



#### DANGER

To avoid bodily injury or death from fall of raised machine, always engage lift cylinder stops before going under header for any reason. See your Combine Operator's Manual for instructions for use and storage of header lift cylinder stops.



#### CAUTION

Stop engine and remove key from ignition before leaving Operator's seat for any reason. A child or even a pet could engage an idling machine.

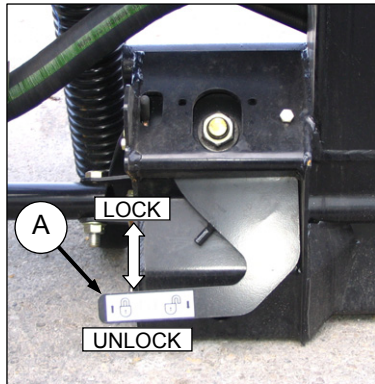

- b. Engage the adapter float locks by lifting lever (A) at both locks until it latches into the lock position.

#### IMPORTANT

If slow speed transport wheels are installed, header may be detached in either transport or field mode. If detaching with wheel in field mode, set wheels to storage or uppermost working position. Otherwise header may tilt forward so that re-attachment will be difficult. Refer to Section 9.11.2 Cutting Height.

#### IMPORTANT

If stabilizer wheels are installed, set wheels to storage or uppermost working position. Otherwise header may tilt forward so that re-attachment will be difficult. Refer to Section 9.11.2 Cutting Height.

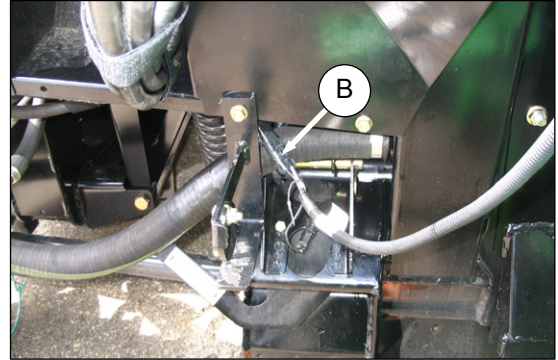

- c. If adapter is equipped with reel fore-aft/header tilt selector, disconnect harness (B) and store on combine.

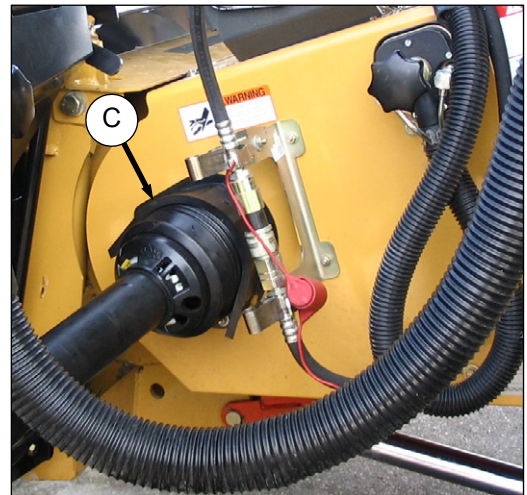

- d. Disconnect driveshaft (C) from combine.

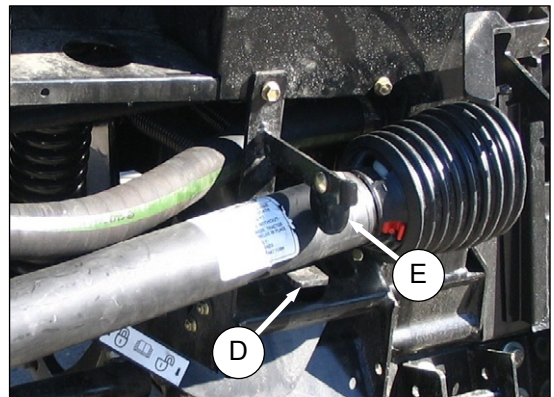

- e. Slide driveshaft in hook (D) so that disc (E) drops to secure driveshaft.

*(continued next page)*



## SECTION 7.6. CAT LEXION 400, 500 SERIES

- f. Disconnect hydraulics/electrical from adapter as follows:

### Lexion 500 Detachment

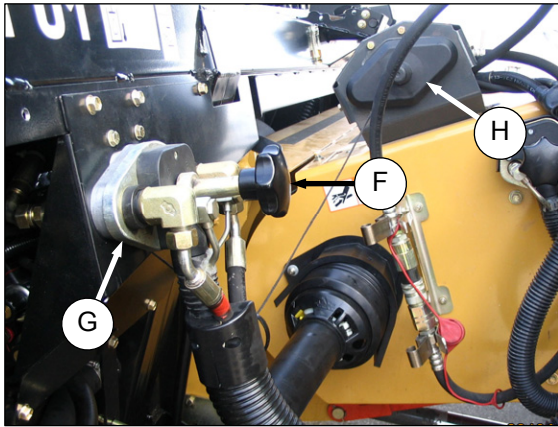

1. Unscrew knob (F) on coupler (G) to release coupler from adapter.
2. Remove cover (H) from combine receptacle.

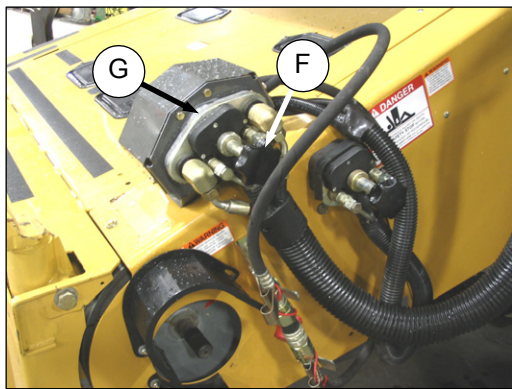

3. Locate coupler (G) onto combine receptacle, and turn knob (F) to secure coupler to receptacle.

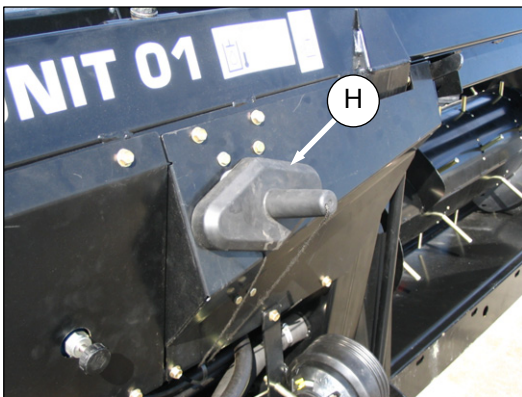

4. Place cover (H) on adapter receptacle.
5. Proceed to step g.

### Lexion 400 Detachment

1. Disconnect electrical harness from adapter.

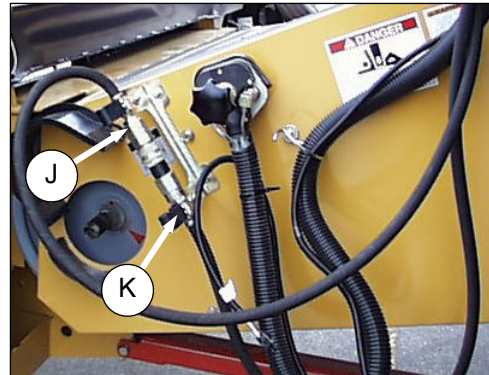
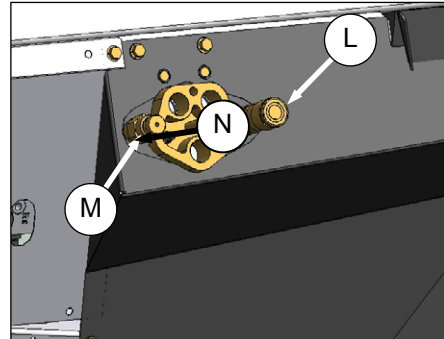

2. Disconnect hydraulic hoses from adapter connectors (L) and (M). Locate hoses (J) and (K) on combine as shown, and reconnect.
3. Unscrew knob on coupler to release coupler from adapter receptacle.

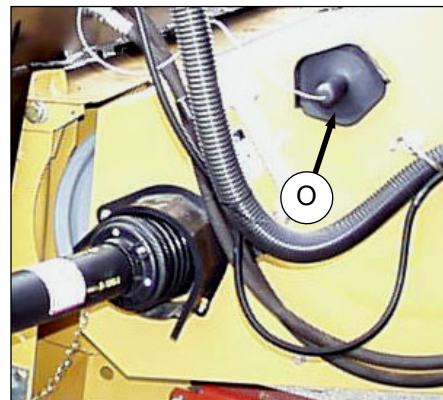

4. Remove cover (O) from combine receptacle (N) and place onto adapter receptacle.

*(continued next page)*

## SECTION 7.6. CAT LEXION 400, 500 SERIES

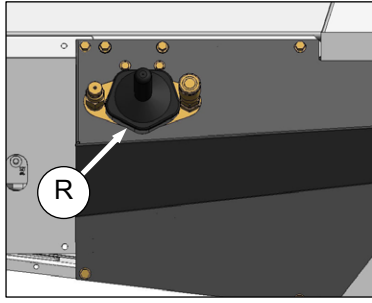

5. Place cover (R) on adapter receptacle.

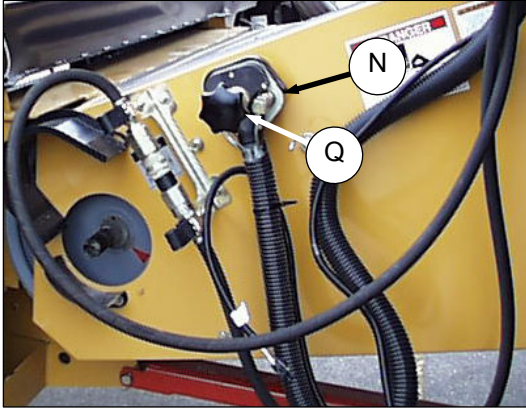
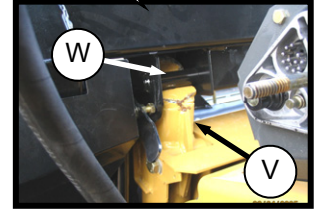
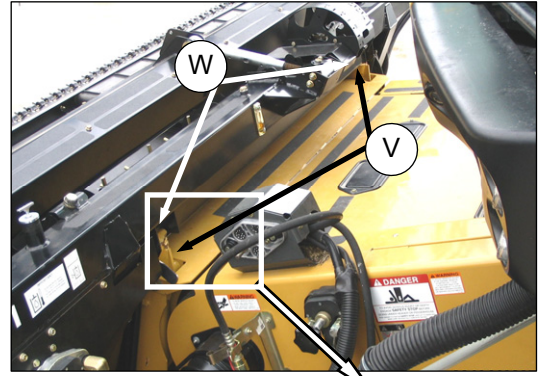

6. Locate coupler (N) onto combine receptacle, and turn knob (Q) to secure coupler to receptacle.

- i. Lower feeder house to ground until feeder house posts (V) disengage adapter (W).
- j. Lower feeder.
- k. Slowly back combine away from adapter.

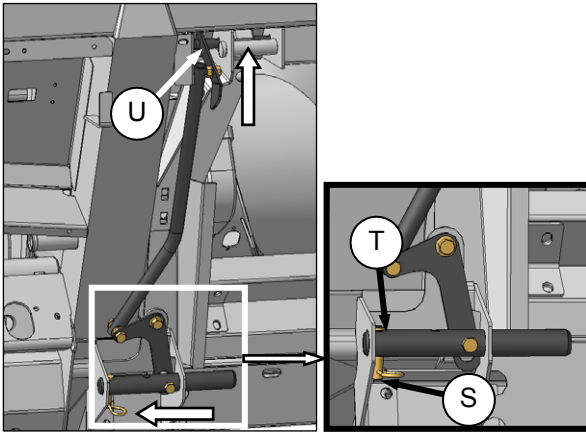

- g. Remove locking pin (S) from adapter pin (T).
- h. Raise handle (U) to disengage adapter pins (T) from feeder house. Replace locking pin (S) in adapter pin and secure with hairpin.



## SECTION 7.7. NEW HOLLAND CR, CX

### 7.7 NEW HOLLAND CR, CX



#### 7.7.1 ATTACHMENT

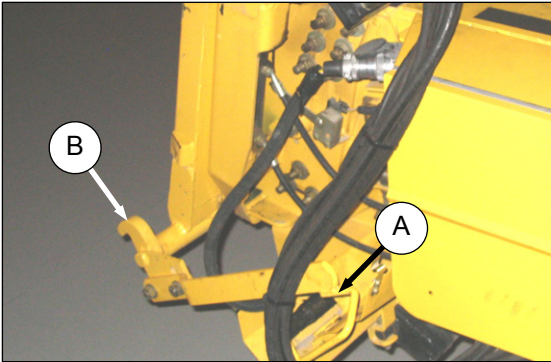

- a. Ensure handle (A) is positioned so that hooks (B) can engage adapter.

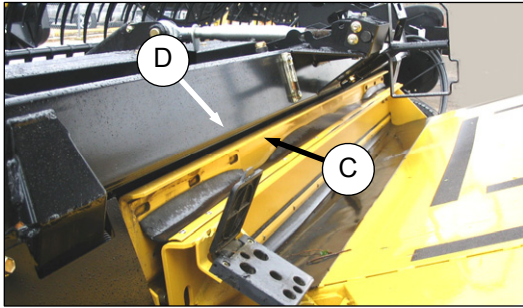

- b. Slowly drive combine up to adapter until feeder house saddle (C) is directly under the adapter top cross member (D).
- c. Raise feeder house to lift adapter, ensuring feeder saddle is properly engaged in adapter frame.



### CAUTION

Stop engine and remove key from ignition before leaving Operator's seat for any reason. A child or even a pet could engage an idling machine.

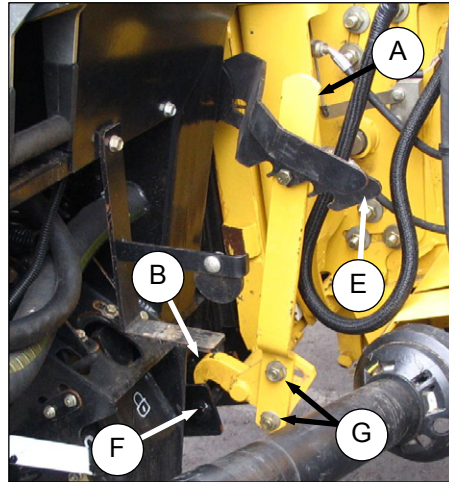

- d. Lift lever (E) on adapter at left side of feeder house and push handle (A) on combine so that hooks (B) engage pins (F) on both sides of the feeder house.
- e. Push down on lever (E) so that slot in lever engages handle to lock handle in place.
- f. If hook (B) does not fully engage pin on adapter when (A) and (E) are engaged, loosen bolts (G) and adjust lock as required. Re-tighten bolts.

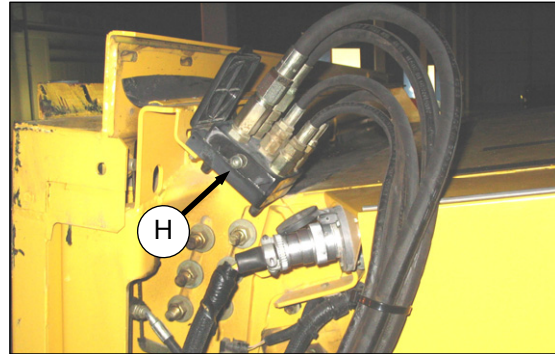

- g. Remove hydraulic quick coupler (H) from storage plate on combine.

*(continued next page)*

## SECTION 7.7. NEW HOLLAND CR, CX

h. Connect to receptacle on adapter as follows:

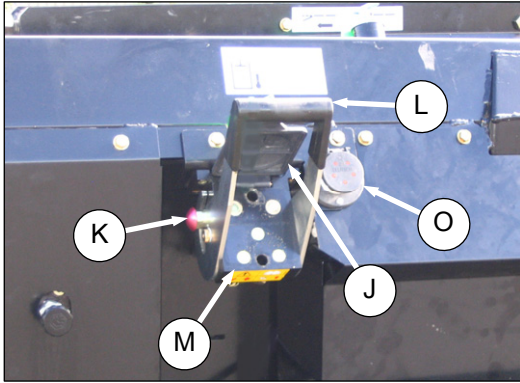

1. Open cover (J).
2. Push in lock button (K) and pull handle (L) halfway up to open position.

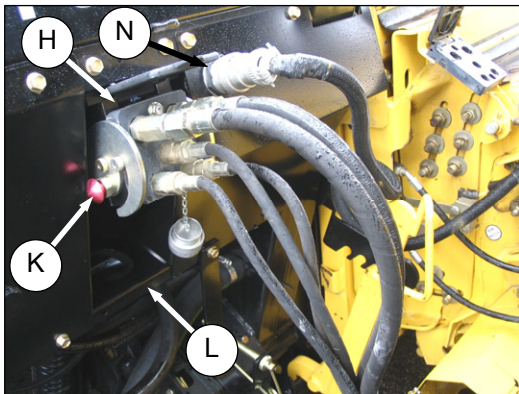

3. Remove coupler (H) from storage location on combine and clean mating surface of coupler.
4. Position coupler onto adapter receptacle (M) and push handle (L) to engage pins into receptacle.
5. Push handle (L) to closed position until lock button (K) snaps out.

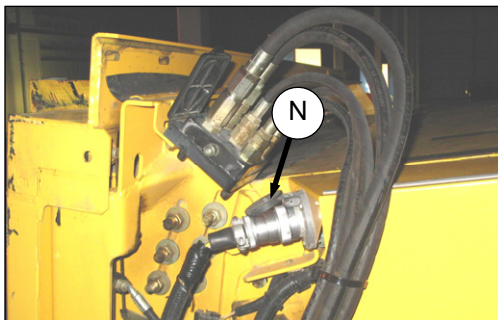

i. Attach combine electrical connector (N) to adapter as follows:

1. Remove cover on adapter electrical receptacle (O).

2. Remove connector (N) from combine.

3. Align lugs on connector (N) with slots in adapter receptacle (O) and push connector onto receptacle. Turn collar on connector to lock it in place.

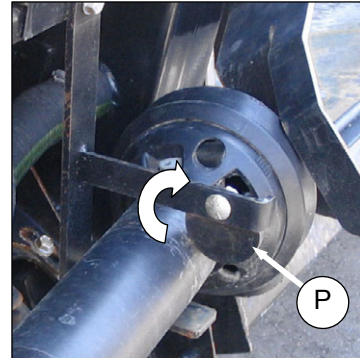

j. Rotate disc (P) on adapter driveline storage hook and remove driveline from hook.

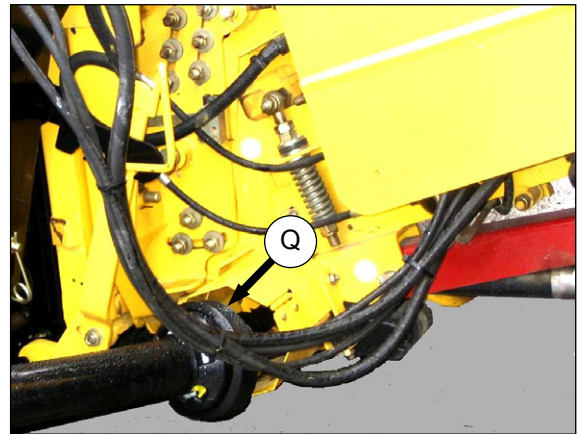

k. Pull back collar on end of driveline and push onto combine output shaft (Q) until collar locks.

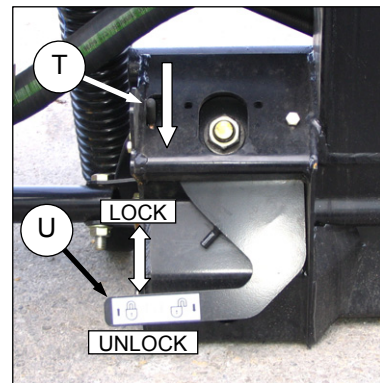

l. Disengage both adapter float locks by moving latch (T) away from adapter and moving lever (U) at each lock to lowest position.



## SECTION 7.7. NEW HOLLAND CR, CX



### IMPORTANT

If stabilizer wheels are installed, set wheels to storage or uppermost working position. Otherwise header may tilt forward so that re-attachment will be difficult. Refer to Section 9.11.2 Cutting Height.

### 7.7.2 DETACHMENT

- a. Choose a level area. Position header slightly off the ground. Stop engine and remove key.



### DANGER

To avoid bodily injury or death from fall of raised machine, always engage lift cylinder stops before going under header for any reason. See your Combine Operator's Manual for instructions for use and storage of header lift cylinder stops.



### CAUTION

Stop engine and remove key from ignition before leaving Operator's seat for any reason. A child or even a pet could engage an idling machine.

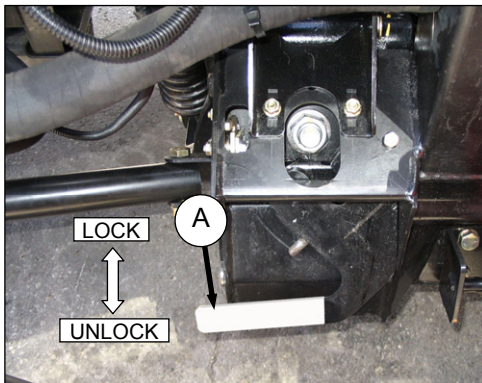

- b. Engage the adapter float locks by lifting lever (A) at each lock until it latches into the lock position.

### IMPORTANT

If slow speed transport wheels are installed, header may be detached in either transport or field mode. If detaching with wheel in field mode, set wheels to storage or uppermost working position. Otherwise header may tilt forward so that re-attachment will be difficult. Refer to Section 9.11.2 Cutting Height.

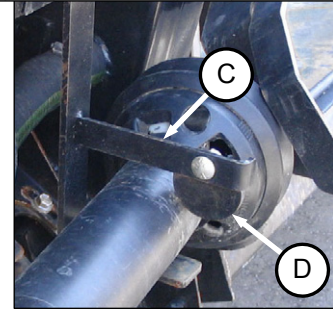
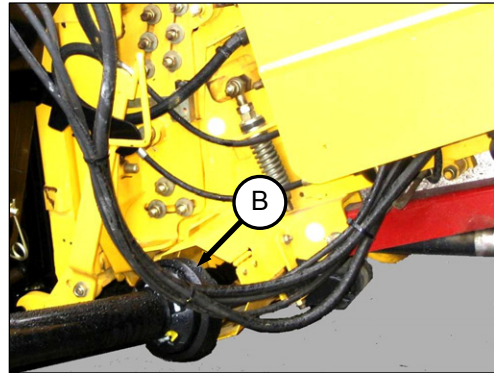

- c. Disconnect driveshaft (B) from combine and slide driveshaft in hook (C) so that disc (D) drops to secure driveshaft.

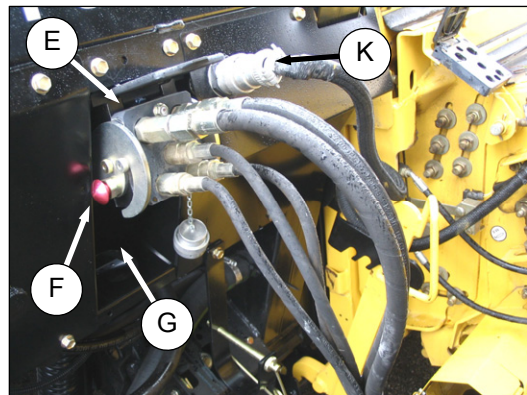

- d. Remove hydraulic quick coupler (E) from receptacle on adapter as follows:
1. Push in lock button (F) and pull handle (G) to release coupler (E).
  2. Push handle (G) to closed position until lock button (F) snaps out. Close cover.

*(continued next page)*



## SECTION 7.7. NEW HOLLAND CR, CX

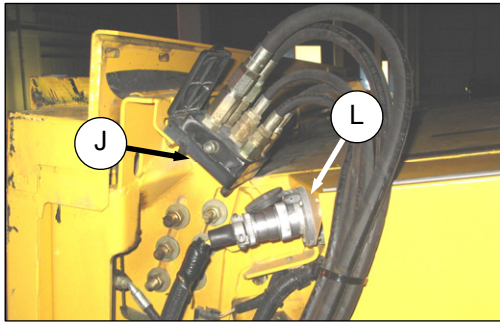

3. Position coupler (E) onto storage plate (J) on combine. (shown on previous page)
- e. Remove electrical connector (K) from adapter and connect to combine at (L). Replace cover on adapter receptacle.

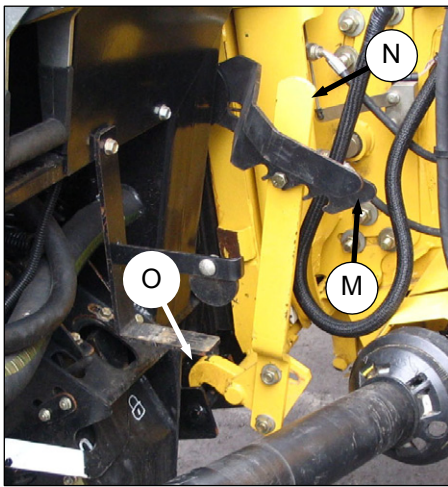

- f. Lift lever (M), and pull and lower handle (N) to disengage feeder house/adapter lock (O).

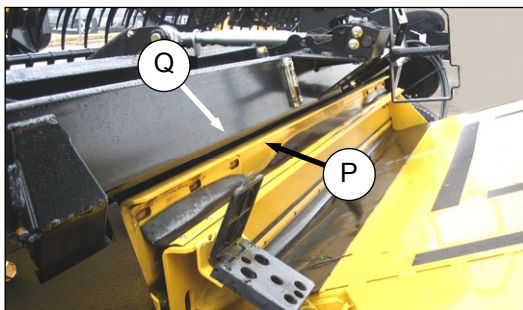

- g. Lower feeder house until feeder house (P) disengages adapter support (Q).
- h. Slowly back combine away from adapter.

## SECTION 7.8. AGCO

### 7.8 AGCO

Gleaner R Series, A Series, Challenger 660, 670, 680B, Massey 9690, 9790, 9895



#### 7.8.1 ATTACHMENT

##### IMPORTANT

Some combine models require special center-link components to ensure clearance to the combine cab.

To avoid damage to your combine, lift feeder slowly and check clearance between cab and header center-link. If clearance is inadequate, contact your MacDon Dealer to order special center-link components. Refer to Section 7.1.1 Center-Link Kit.

- a. Retract lugs (A) at base of feeder-house with lock handle (B) (see picture opposite column).

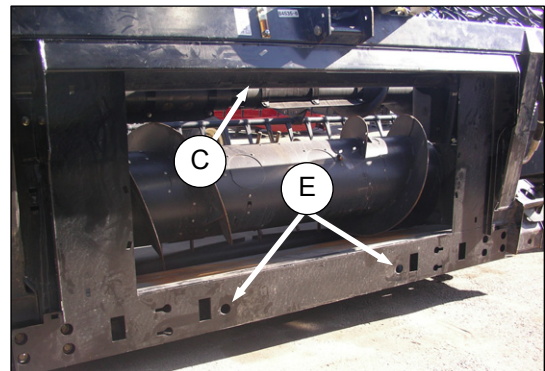
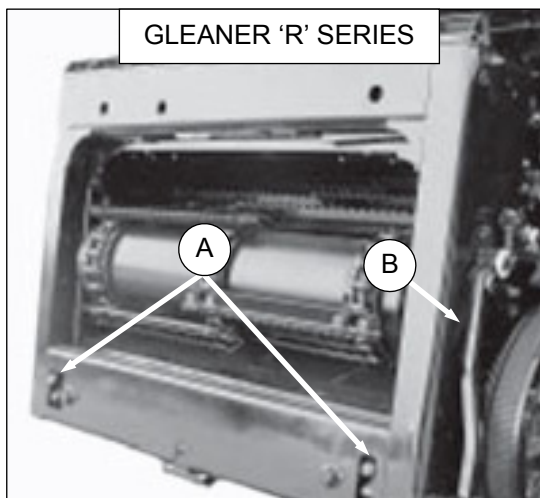
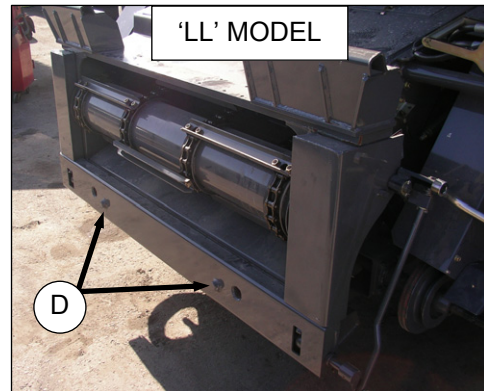
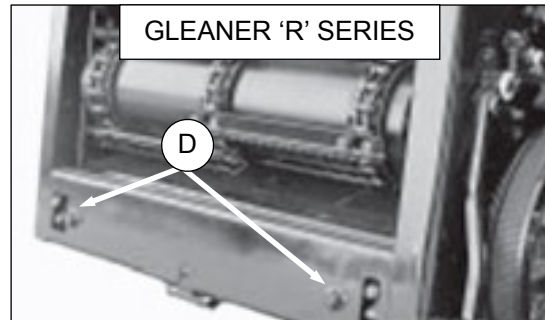
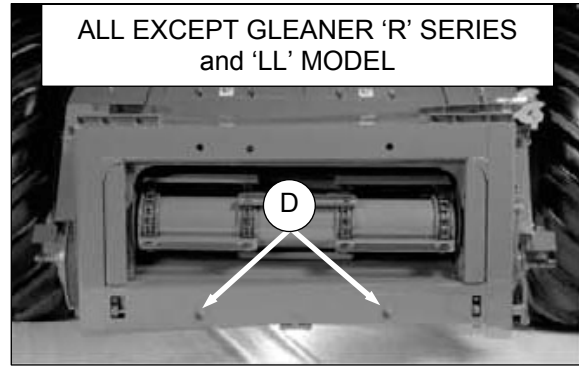

- b. Slowly drive combine up to adapter until feeder house is directly under the adapter top cross member (C) and alignment pins (D) are aligned with holes (E) in adapter frame.

(continued next page)



## SECTION 7.8. AGCO

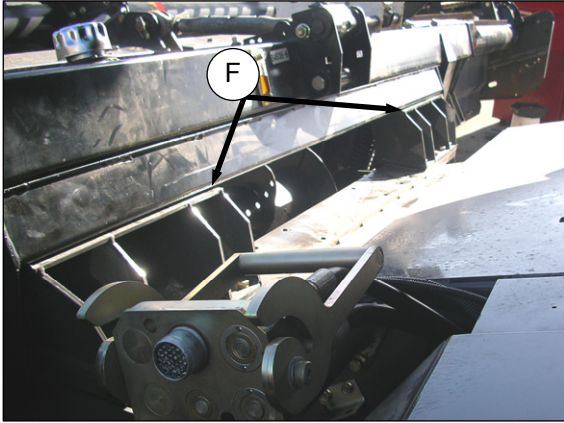

- c. Raise feeder house to lift adapter, ensuring feeder house saddle (F) and alignment pins are properly engaged in adapter frame.
- d. Raise header slightly off the ground.



### CAUTION

Stop engine and remove key from ignition before leaving Operator's seat for any reason. A child or even a pet could engage an idling machine.

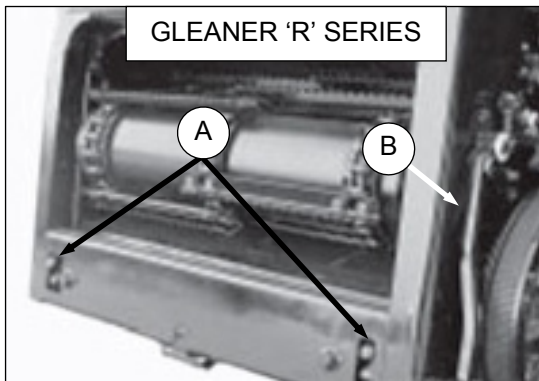

- e. Engage lugs (A) with adapter using lock handle (B).

- f. Connect adapter hydraulic quick coupler to combine receptacle as follows:

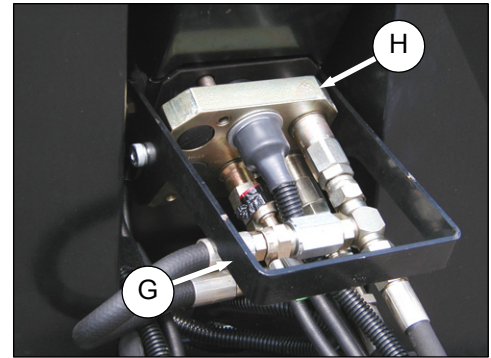

- 1. Pull handle (G) to release coupler (H) from adapter.

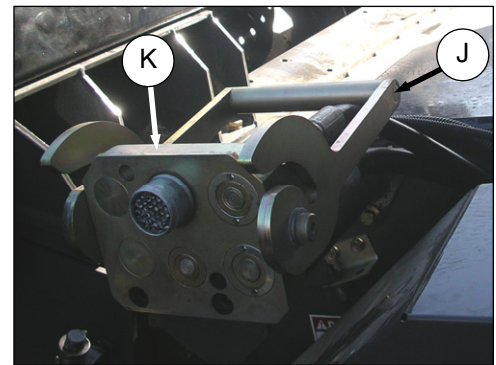

- 2. Push handle (J) on combine to full open position.
- 3. Clean mating surfaces of coupler and receptacle if necessary.
- 4. Position coupler (H) onto combine receptacle (K) and pull handle (J) to fully engage coupler into receptacle.

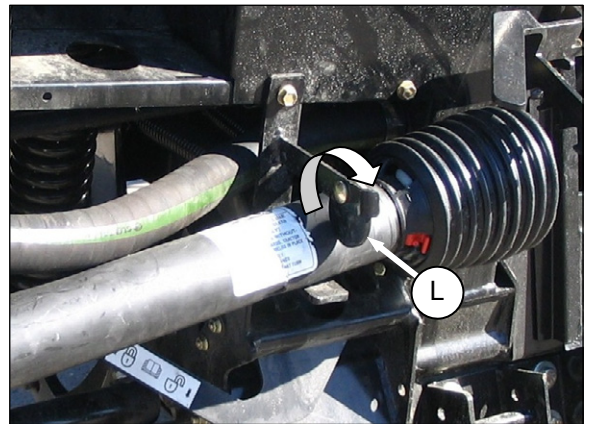

- g. Rotate disc (L) on adapter driveline storage hook and remove driveline from hook.

*(continued next page)*

## SECTION 7.8. AGCO

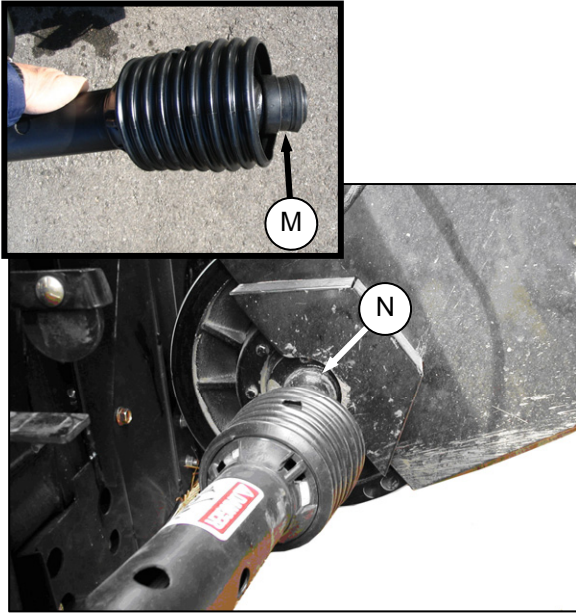

- j. Disengage both adapter float locks by moving latch (Q) away from adapter and moving lever (R) at each lock to lowest position.

- h. Pull back collar (M) on end of driveline and push onto combine output shaft (N) until collar locks.

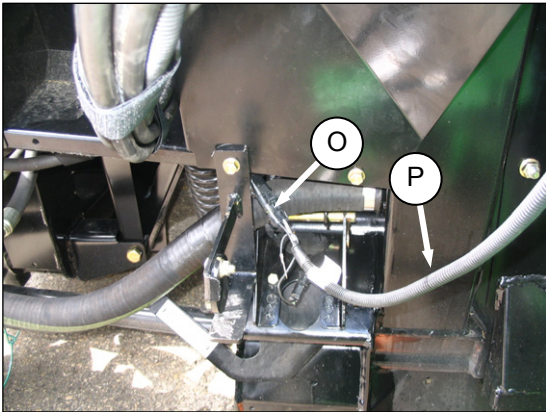

- i. Connect selector valve wire harness (O) to combine harness (P).

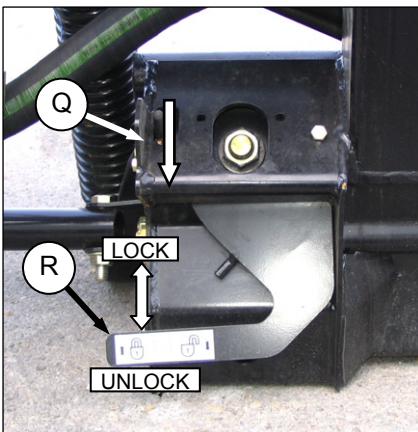



## SECTION 7.8. AGCO



### 7.8.2 DETACHMENT

- Choose a level area. Position header slightly off the ground. Stop engine and remove key



#### DANGER

To avoid bodily injury or death from fall of raised machine, always engage lift cylinder stops before going under header for any reason. See your Combine Operator's Manual for instructions for use and storage of header lift cylinder stops.



#### CAUTION

Stop engine and remove key from ignition before leaving Operator's seat for any reason. A child or even a pet could engage an idling machine.

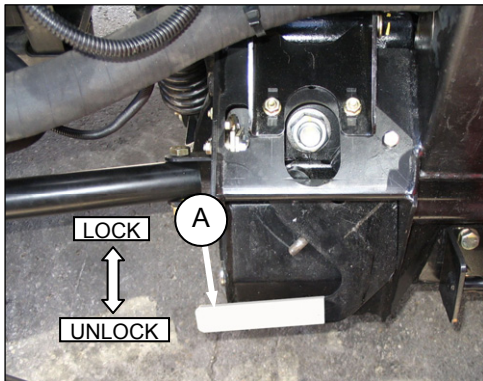

- Engage the adapter float locks by lifting lever (A) at each lock until it latches into the lock position.

#### IMPORTANT

If slow speed transport wheels are installed, header may be detached in either transport or field mode. If detaching with wheel in field mode, set wheels to storage or uppermost working position. Otherwise header may tilt forward so that re-attachment will be difficult. Refer to Section 9.11.2 Cutting Height.

#### IMPORTANT

If stabilizer wheels are installed, set wheels to storage or uppermost working position. Otherwise header may tilt forward so that re-attachment will be difficult. Refer to Section 9.11.2 Cutting Height.

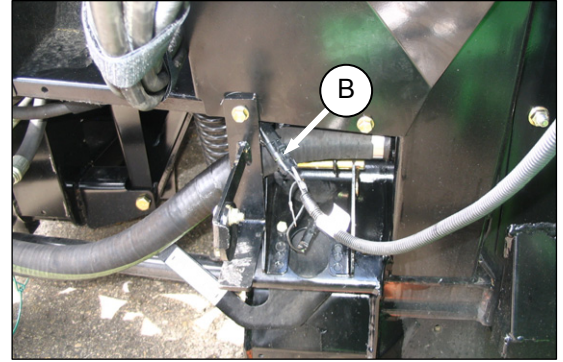

- If adapter is equipped with reel fore-aft/header tilt selector, disconnect harness (B) and store on combine.

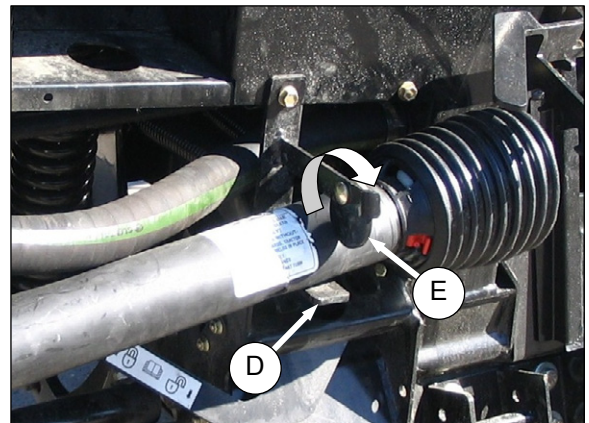

- Disconnect driveshaft (C) from combine and slide driveshaft in hook (D) so that disc (E) drops to secure driveshaft.

*(continued next page)*

## SECTION 7.8. AGCO

- e. Disconnect hydraulic/electrical coupler from combine as follows:

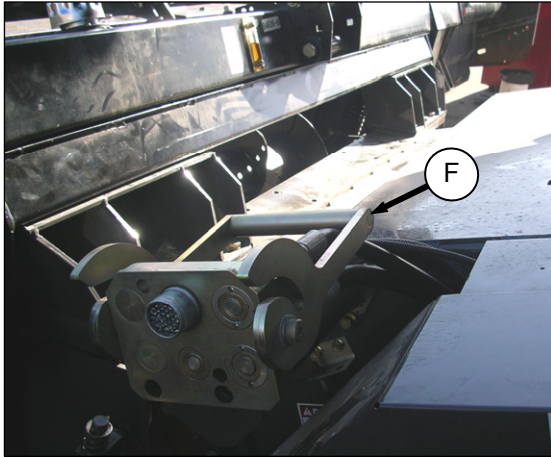

1. Move handle (F) to full open position to release coupler from combine.

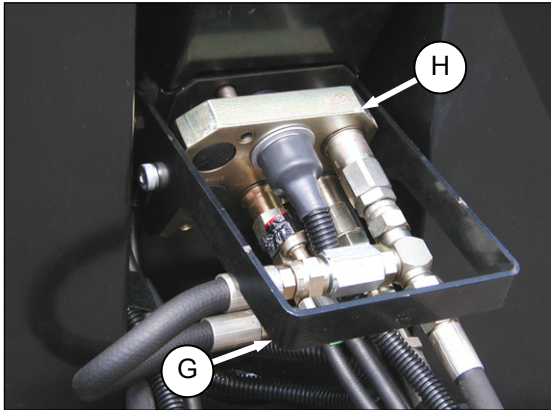

2. Lift handle (G) on adapter, position coupler (H) in adapter and lower handle (G) to lock coupler.

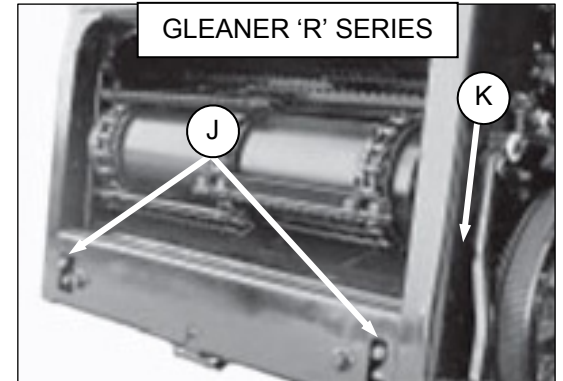

- f. Retract lugs (J) at base of feeder-house with lock handle (K).

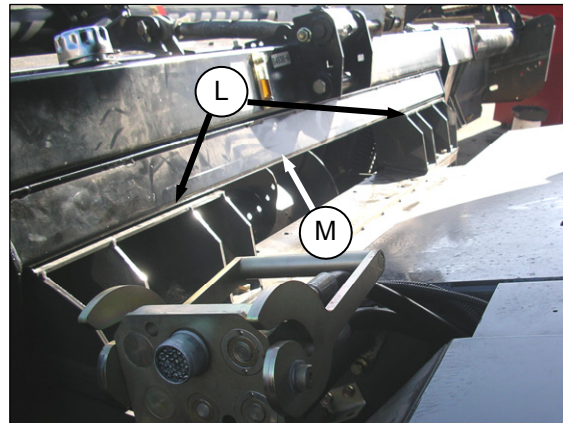

- g. Lower feeder house until saddle (L) disengages and clears adapter support (M).  
h. Slowly back combine away from adapter.



## SECTION 8.1. D50, D60 HEADER AND ADAPTER

# 8 HEADER/ADAPTER DISASSEMBLY AND ASSEMBLY

Using this procedure, the adapter remains attached to the combine and is appropriate when:

- detaching the headers for use on a windrower,
- changing headers, or
- performing certain maintenance tasks.

The procedure is the same for all makes and models of combines. The headers can be attached to the adapter from either field configuration or transport configuration.



### 8.1 D50 AND D60 HARVEST HEADER/ADAPTER

#### 8.1.1 DISASSEMBLY

- a. Choose a level area, lower header to ground, and raise reel fully. Set header tilt to almost full forward to increase clearance under adapter feed draper.



#### CAUTION

Stop engine and remove key from ignition before leaving Operator's seat for any reason. A child or even a pet could engage an idling machine.

- b. Stop engine, remove key, and engage reel props.
- c. Disconnect adapter deck from cutterbar as follows:



#### WARNING

Keep hands clear of the area between guards and sickle at all times.

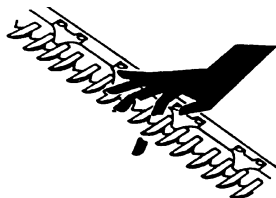

#### CAUTION

Wear heavy gloves when working around or handling sickles.

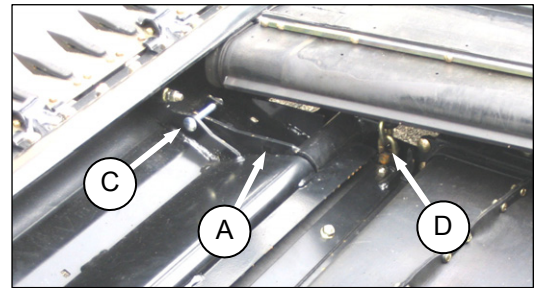
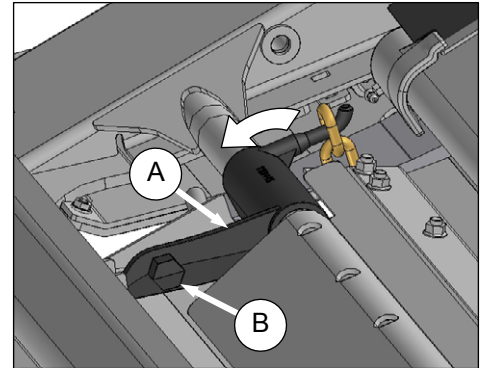

1. Rotate latch (A) with a 15/16 wrench (or equivalent) on hex (B) to raise feed deck so that bolt (C) can be removed. Repeat for other side of feed deck..
2. Rotate latches to lower adapter deck.
3. Remove chain (D) from hook. Rotate latch back to original position and reinstall bolts (C).

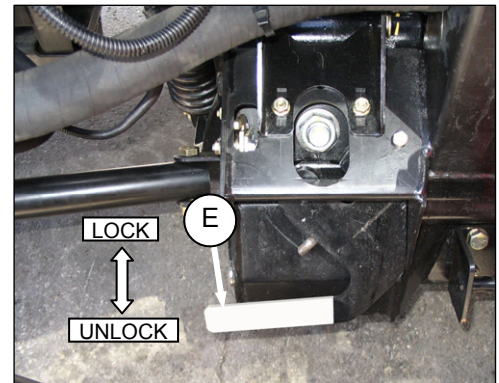

- d. Engage the adapter float locks by lifting lever (E) until it latches into the lock position.

#### NOTE

Stabilizer/Transport wheels can be used in combination with the stand to support header. Refer to Section 9.11.2 Cutting Height.

(continued next page)

## SECTION 8.1. D50, D60 HEADER AND ADAPTER

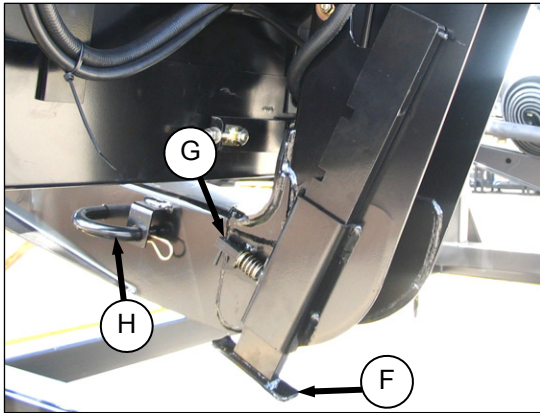

- e. Lower stand (F) by pulling spring loaded pin (G). Release pin when stand at desired height.
- f. Remove pin (H) from leg on both sides of adapter.
- g. Disconnect **hook type** hydraulic center-link as follows:

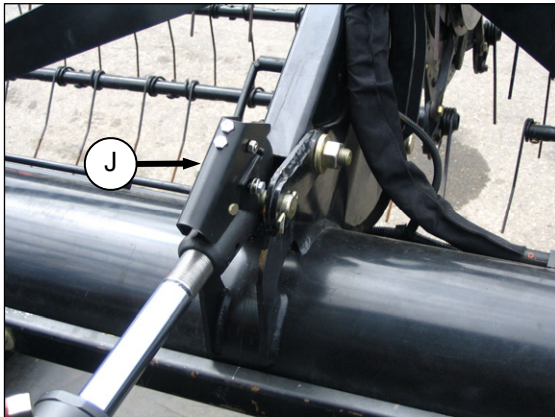

1. Lift release (J) and latch it in up position.
2. Extend center-link cylinder to disengage hook from header.
3. Prop up center-link with a pin or equivalent tool.

- h. Disconnect **eye type** hydraulic center-link as follows:

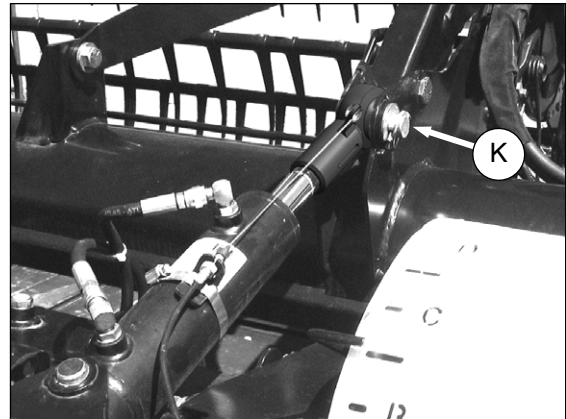

1. Operate center-link hydraulics until pin (K) is loose.
  2. Remove pin (K) and lift center-link clear of bracket.
  3. Replace pin (K) and secure with lynch pin.
- i. Disconnect mechanical link as follows:

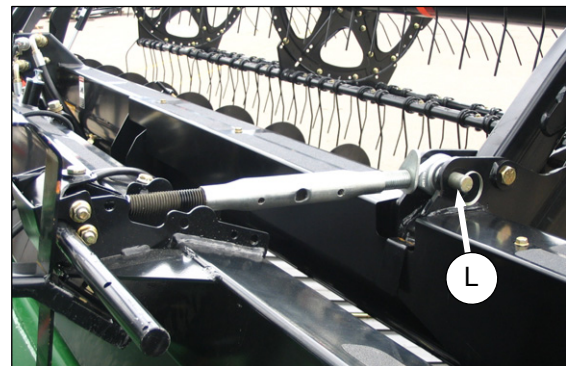

1. Remove pin (L) to release link. Replace pin.

### NOTE

*Feeder house may need to be raised or lowered, or length of link adjusted, to relieve load on link.*

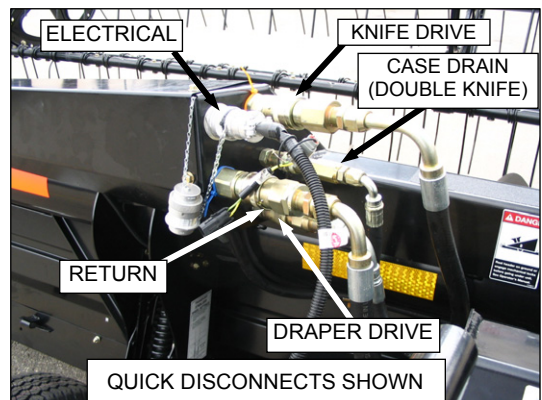

- j. Disconnect sickle and draper drive hydraulic hoses. Install caps and plugs on fittings.

*(continued next page)*



## SECTION 8.1. D50, D60 HEADER AND ADAPTER

- k. If quick disconnects are installed, disconnect as follows:

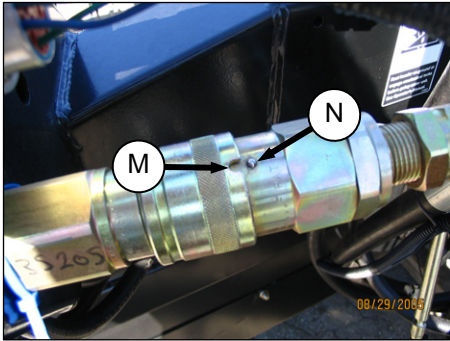

1. Line up slot (M) in collar with pin (N) on connector.
  2. Push collar toward pin and pull connector to disengage.
  3. Install plugs or caps on hose ends (if equipped).
- l. Disconnect electrical connector by turning collar counter clockwise and pulling connector to disengage.

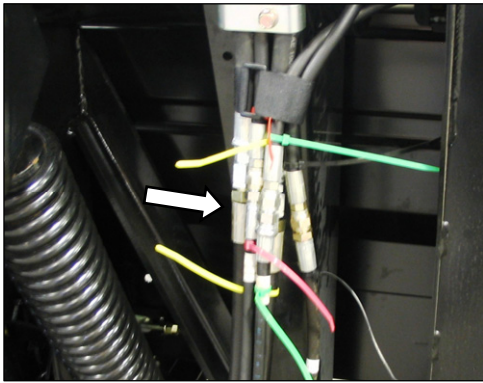

- m. Store and secure hoses on adapter.  
n. Disconnect reel hydraulics at right side of adapter. Install caps and plugs on fittings.

- o. If multi-coupler is installed, disconnect as follows:

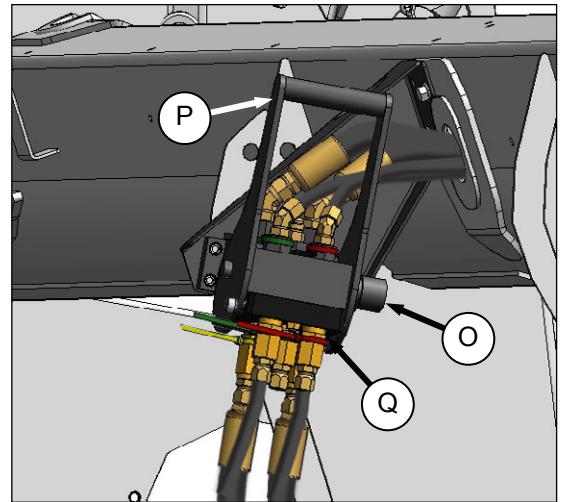

1. Push in lock button (O) and pull handle (P) to release coupler (Q).
2. Push handle down until button (O) snaps out.



3. Store hoses over adapter frame.
- p. Ensure header is on ground or supported by wheels in transport mode or jack stand.  
q. Slowly back combine away from header.

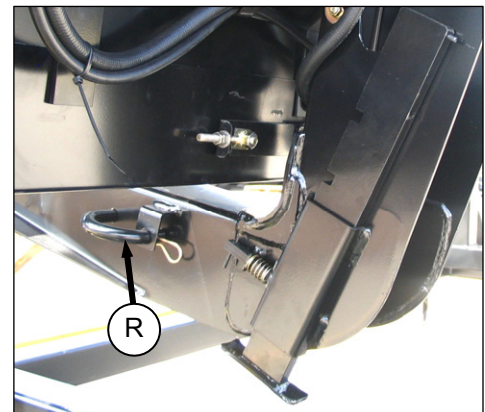

- r. Reinsert pins (R) in legs of header.

## SECTION 8.1. D50, D60 HEADER AND ADAPTER



### 8.1.2 ASSEMBLY

The D50 and D60 Harvest Header can be attached to the adapter from either field configuration or transport configuration.

#### NOTE

*Stabilizer/Transport wheels can be used in combination with the stand to support header.*

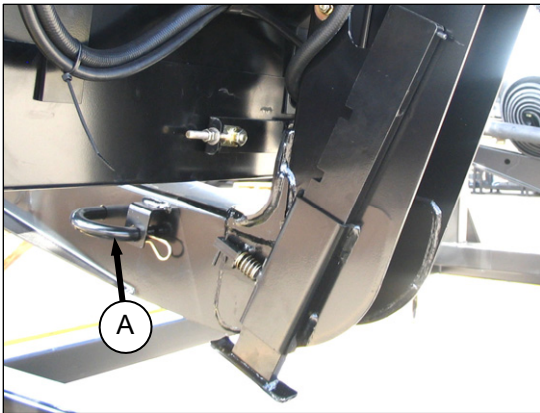

- Remove lynch pin and remove pin (A) from each header leg. Temporarily store in safe place for reinstallation.
- If not installed, install vibration dampers on ends of adapter arms as follows:

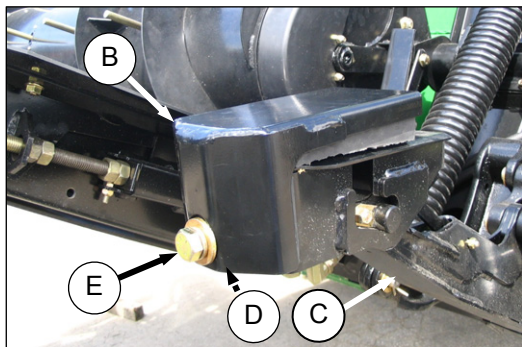

- Locate damper (B) onto adapter arm (C).
- Secure with spacer (D), bolt (E), washer, and lock-washer.

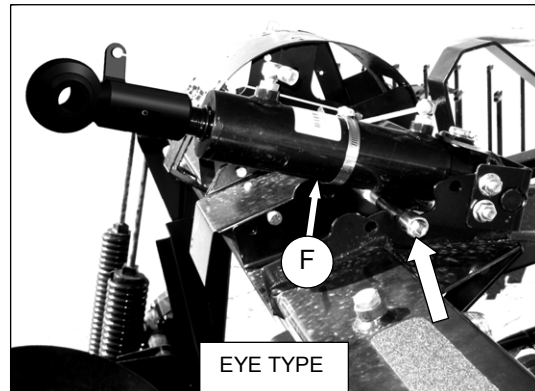
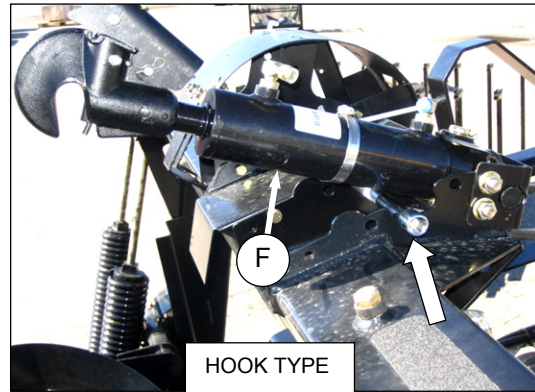

- Prop up center-link (F) (hydraulic shown) with pin or equivalent tool.

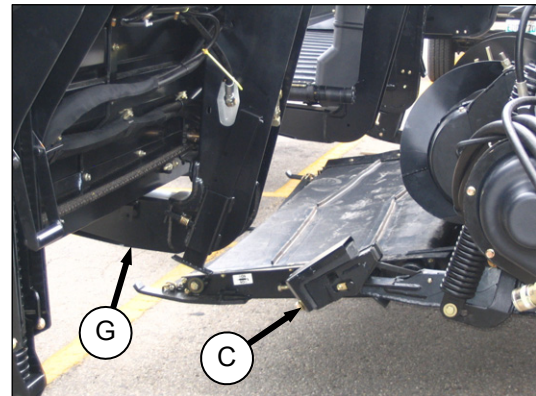

- Lower combine feeder house so that adapter arms (C) are aligned with header legs (G).
- Slowly drive forward, again aligning adapter arms and header legs.
- Keep adapter arm (C) height just under the header leg (G) to ensure adapter leg seats properly in the header linkage supports.

#### IMPORTANT

Keep hydraulic hoses clear to prevent damage when driving into header.

- Continue forward until adapter arm contacts stop in header leg. Raise adapter slightly.

*(continued next page)*



## SECTION 8.1. D50, D60 HEADER AND ADAPTER

- h. Connect **hook type** hydraulic center-link as follows:

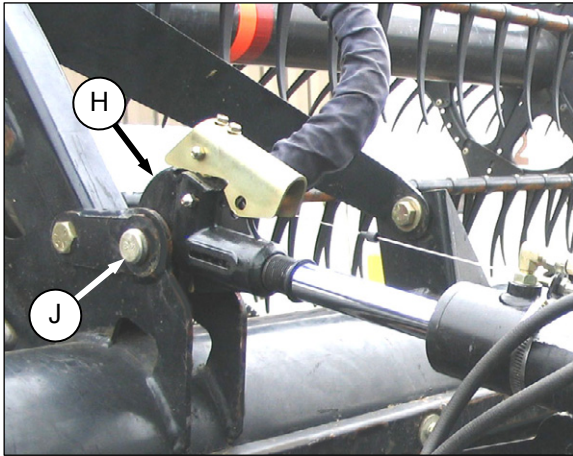

1. Extend hook (H) and remove prop under link so that base of hook rests on pin (J).
2. Operate header angle hydraulics to retract hook until it engages pin and self-latches.



### CAUTION

**Stop engine and remove key from ignition before leaving Operator's seat for any reason. A child or even a pet could engage an idling machine.**

3. Shutdown engine and remove key.
  4. Ensure hook (H) is securely attached.
  5. Proceed to step k.
- i. Connect **eye type** hydraulic center-link as follows:
1. Shutdown engine and remove key.

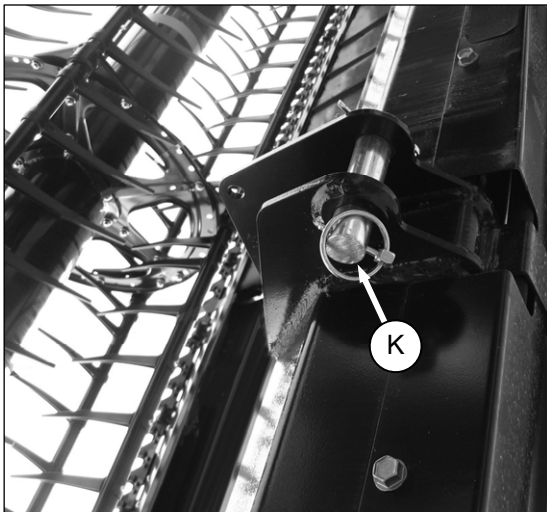

2. Remove pin (K) and the prop under link.

3. Adjust length of link by operating header angle hydraulics to align with header bracket.

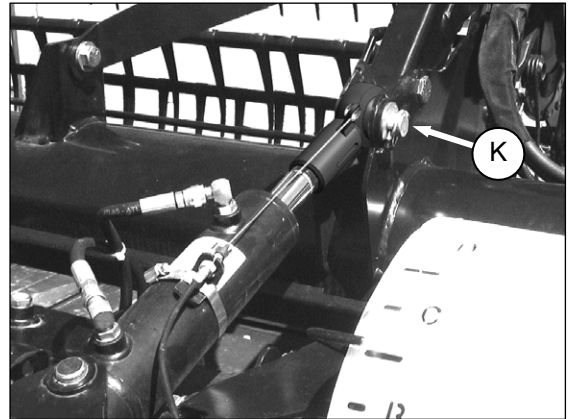

4. Insert pin (K) and secure with lynch pin.
- j. Connect mechanical center-link as follows:
1. Shutdown engine and remove key.

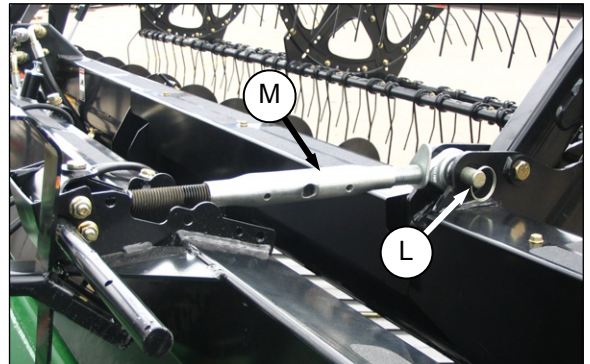

2. Remove pin (L) and the prop under link.
3. Adjust length of link by turning barrel (M) to align with header bracket.
4. Insert pin (L) and secure with lynch pin.

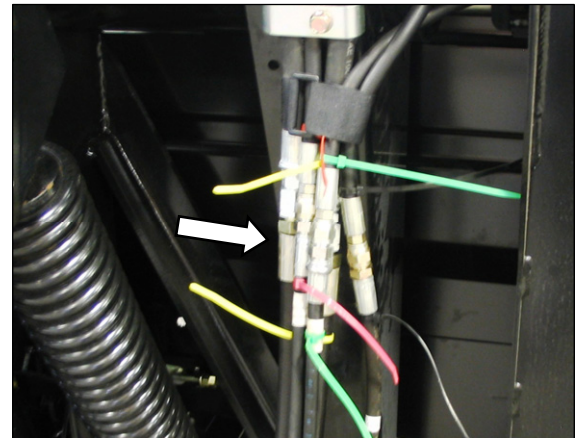

- k. Connect reel hydraulics matching coloured plastic ties.

*(continued next page)*

## SECTION 8.1. D50, D60 HEADER AND ADAPTER

l. If multi-coupler is installed, connect as follows:

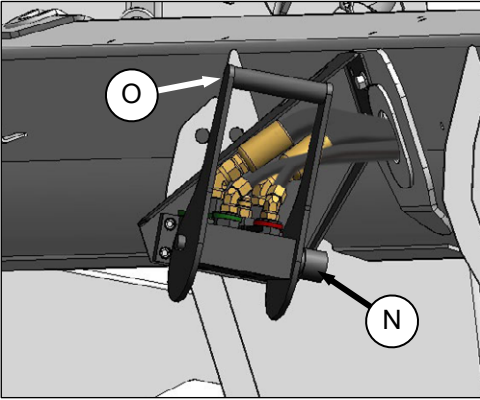

1. Push in lock button (N) and pull handle (O) to full open position.
2. Clean couplers.

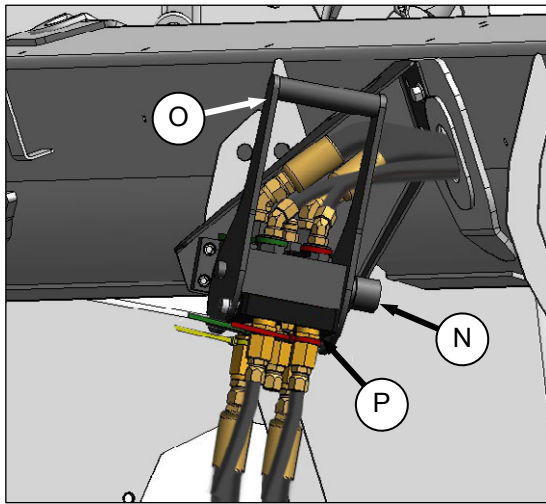

3. Position coupler (P) from combine onto receptacle and push handle (O) to engage pins on coupler.
4. Push handle to closed position until lock button (N) snaps out.

m. Secure header to adapter as follows:

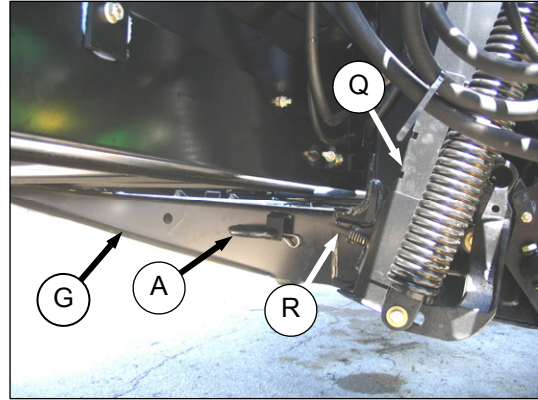

1. Ensure adapter arm is properly located in header leg (G). Reinstall pin (A) in each leg to lock header to adapter and secure with lynch pin.
  2. Return stand (Q) to storage position and secure with pin (R).
- n. Lower header to ground.
- o. Tilt header to almost full forward position to increase clearance under adapter feed draper.



### CAUTION

**Stop engine and remove key from ignition before leaving Operator's seat for any reason. A child or even a pet could engage an idling machine.**

- p. Raise reel, shut off engine, and remove key. Engage reel props.

*(continued next page)*

## SECTION 8.1. D50, D60 HEADER AND ADAPTER

- q. Attach adapter deck to header cutterbar as follows:



### WARNING

Keep hands clear of the area between guards and sickle at all times.

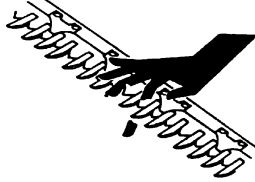

### CAUTION

Wear heavy gloves when working around or handling sickles.

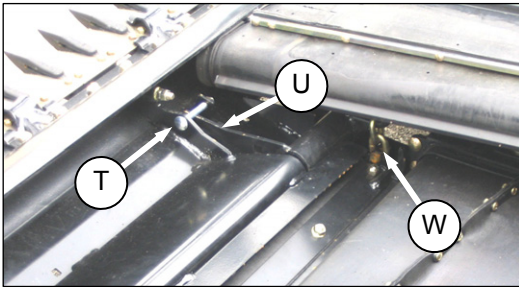

1. If installed, remove bolts (T) at either side of opening to allow attachment of adapter deck.

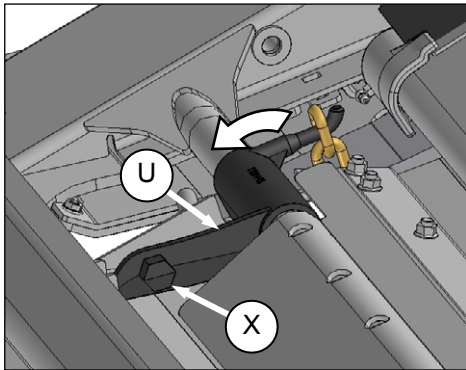

2. Position latches (U) on transition pan so that chain (W) can be attached to the latch hook.
3. Rotate latch (U) with a 15/16 wrench (or equivalent) on hex (X) to raise feed deck so that bolt (T) can be reinstalled. Repeat for other side of feed draper.

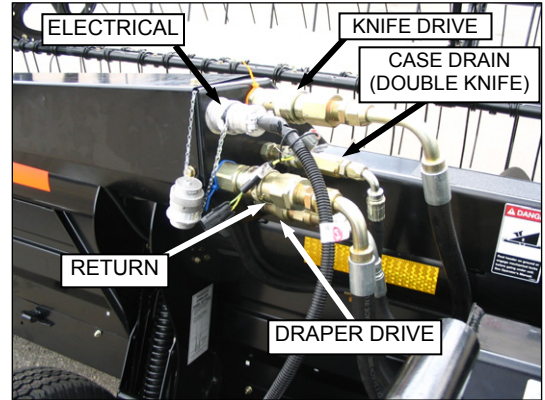

- r. Connect knife and draper drive hydraulics as shown above using colored plastic ties as a guide.
- s. If quick disconnects are installed, proceed as follows:
  1. Check connectors and clean if required.
  2. Push hose connector onto mating receptacle until collar on receptacle snaps into lock position.

#### NOTE

Ensure hoses are clear of driveline and adjacent structure.

- t. Attach electrical connector as follows:

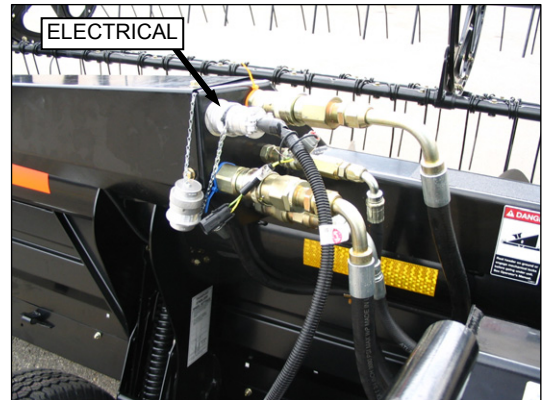

1. Remove cover on receptacle.
2. Align lugs on connector with slots in receptacle, push connector onto receptacle and turn collar on connector to lock it in place.
3. Attach cover to mating cover on combine wiring harness.

(continued next page)



## SECTION 8.1. D50, D60 HEADER AND ADAPTER

- u. Raise and lower header and reel a few times to allow trapped air to pass back to the reservoir.

**NOTE**

*It is not necessary to bleed the system by loosening fittings.*

- v. Check float and if the header is level. If adjustments are required, refer to Section 9.11.3 Header Float, and Section 9.14 HEADER LEVELLING.



## SECTION 8.2. FD70 FLEXDRAPER AND ADAPTER

### 8.2 FD70 FLEXDRAPER/ADAPTER



#### 8.2.1 DISASSEMBLY

- a. Choose a level area, and place 6 inch (150 mm) blocks under hinge area of cutterbar.

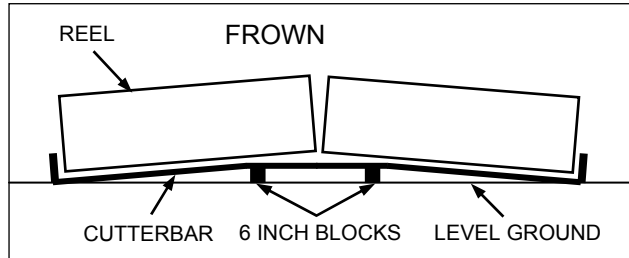

- b. Lower header onto blocks so that header goes into a full frown.  
 c. Fully retract tilt cylinder and raise reel fully.  
 d. Stop engine, remove key, and engage reel props. Refer to Section 9.9 REEL PROPS.

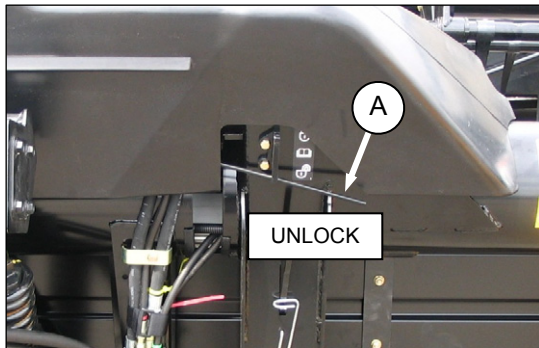

- e. Place spring handles (A) in the lower slot to UNLOCK.



#### CAUTION

Stop engine and remove key from ignition before leaving Operator's seat for any reason. A child or even a pet could engage an idling machine.

- f. Remove the wing float linkage springs from the adapter as follows:

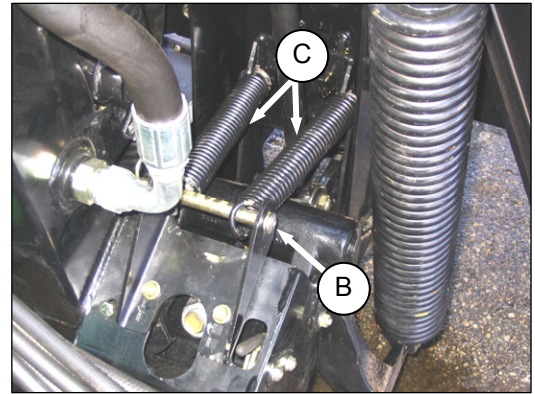

1. Remove pin (B) from bracket so that springs (C) drop free.
  2. Reinstall pin in bracket and secure pin with hairpin.
- g. Disconnect adapter deck from cutterbar as follows:
1. Start engine and tilt header to almost full forward position to increase clearance under adapter feed draper.
  2. Stop engine and remove key.



#### WARNING

Keep hands clear of the area between guards and sickle at all times.

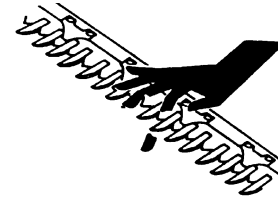

#### CAUTION

Wear heavy gloves when working around or handling sickles.

*(continued next page)*

## SECTION 8.2. FD70 FLEXDRAPER AND ADAPTER

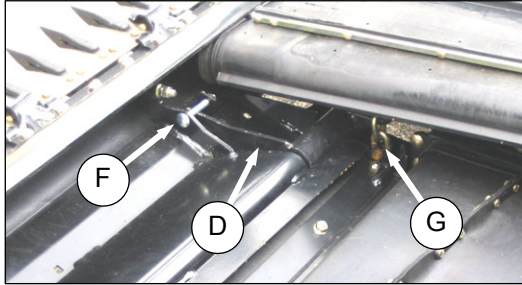
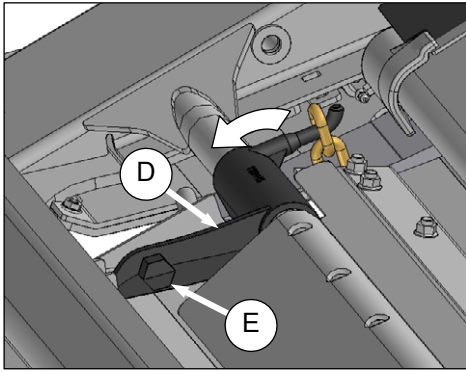

3. Rotate latch (D) with a 15/16 wrench on hex (E) to raise feed deck so that bolt (F) can be removed. Repeat for other side of feed draper deck.
4. Rotate latches to lower adapter deck.
5. Remove chain (G) from hook. Rotate latch back to original position and reinstall bolts (F).

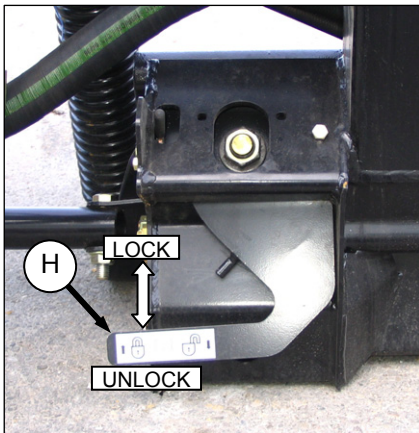

- h. Engage the adapter float locks by lifting lever (H) until it latches into the lock position.

### NOTE

*Stabilizer/Transport wheels can be used in combination with the stand to support header.*

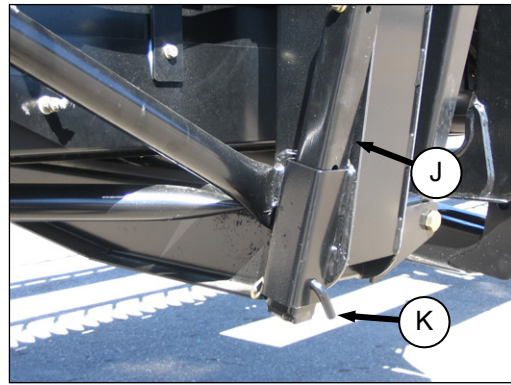

- i. Lower stand (J) by removing pin (K). Reinstall pin when stand at desired height.

### NOTE

*45 foot header does not have a stand.  
Use blocks at this location.*



## DANGER

**To avoid bodily injury or death from fall of raised machine, always engage lift cylinder stops before going under header for any reason. See your Combine Operator's Manual for instructions for use and storage of header lift cylinder stops.**

- j. Disengage reel props, start engine, lower reel and raise header fully. Stop engine, remove key, and engage combine lift cylinder locks.



- k. Remove bolt (L), washer, and spacer from leg on both sides of adapter. Retain for later re-installation.
- l. Disengage lift cylinder locks and lower header to blocks and allow the header wings to go into full frown mode. Stop engine and remove key.



## CAUTION

**Stop engine and remove key from ignition before leaving Operator's seat for any reason. A child or even a pet could engage an idling machine.**

*(continued next page)*

## SECTION 8.2. FD70 FLEXDRAPER AND ADAPTER

- m. Disconnect **hook type** hydraulic center-link as follows:

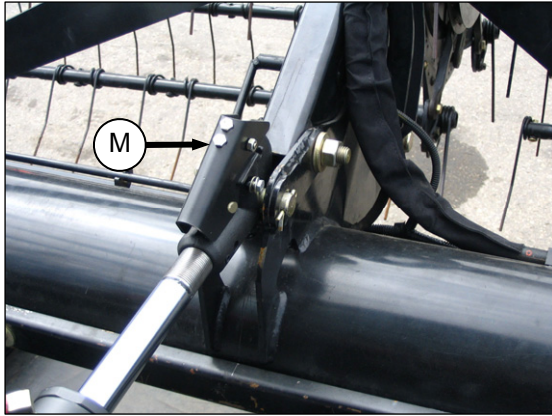

1. Lift release (M) and latch it in up position.
2. Extend center-link cylinder to disengage hook from header. Stop engine and remove key.
3. Prop up center-link with a pin or equivalent tool.
4. Go to step o.

- n. Disconnect **eye type** hydraulic center-link as follows:

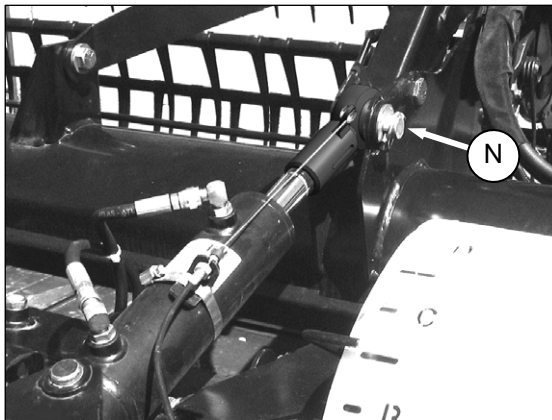

1. Remove pin (N) and lift center-link clear of bracket.
2. Replace pin (N) and secure with lynch pin.

### NOTE

*Feeder house may need to be raised or lowered, or length of link adjusted to relieve load on link.*

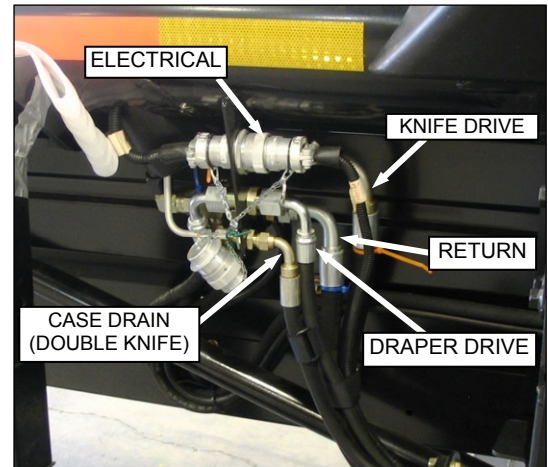

- o. Disconnect knife and draper drive hydraulic hoses.
- p. If quick disconnects are installed, disconnect as follows:

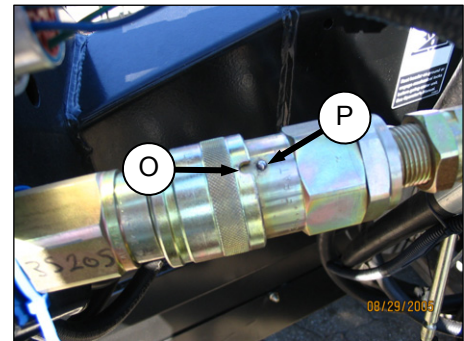

1. Line up slot (O) in collar with pin (P) on connector.
  2. Push collar toward pin and pull connector to disengage.
  3. Install plugs or caps on hose ends (if equipped).
- q. Disconnect electrical connector by turning collar counter clockwise and pulling connector to disengage.
  - r. Store and secure hoses on adapter.

*(continued next page)*



## SECTION 8.2. FD70 FLEXDRAPER AND ADAPTER

s. Disconnect reel hydraulics as follows:

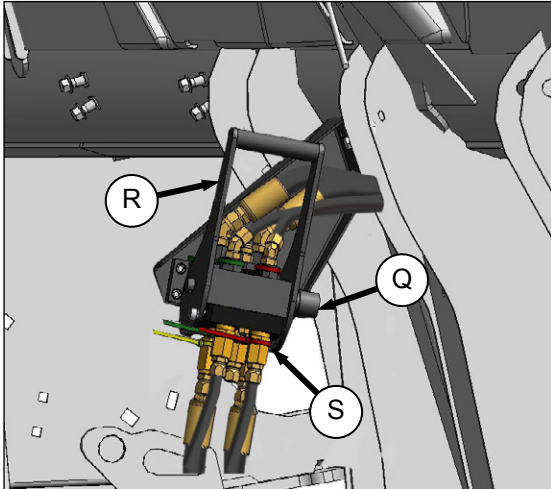

1. Push in lock button (Q) and pull handle (R) to release coupler (S).
2. Push handle down until button (Q) snaps out.

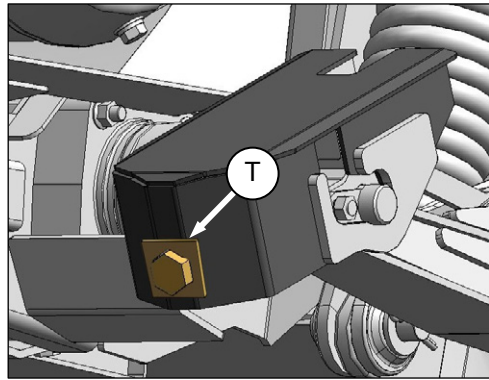

v. Reinstall bolts (T), washers, and spacers removed in step k. into adapter legs.

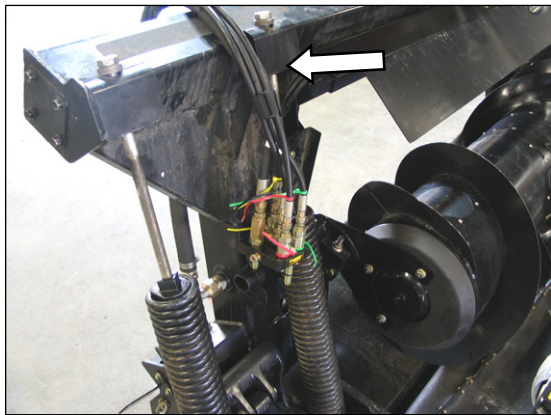

3. Store hoses over adapter frame.
- t. Ensure header is on ground or supported by wheels in transport mode.
- u. Start engine and slowly back combine away from header. Stop engine and remove key.

## SECTION 8.2. FD70 FLEXDRAPER AND ADAPTER



### 8.2.2 ASSEMBLY

The FD70 FlexDraper can be attached to the adapter from either field configuration or transport configuration.

#### NOTE

*Stabilizer/Transport wheels can to be used in combination with the stand to support header. Refer to Section 9.11.2 Cutting Height.*

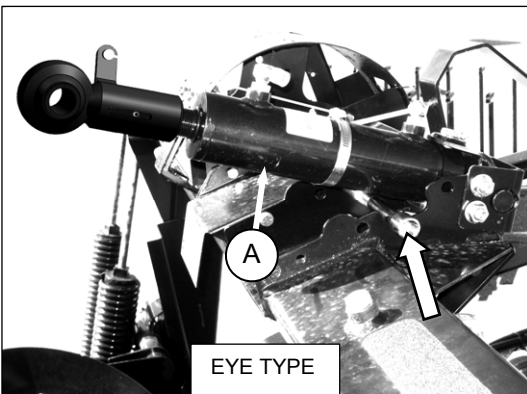
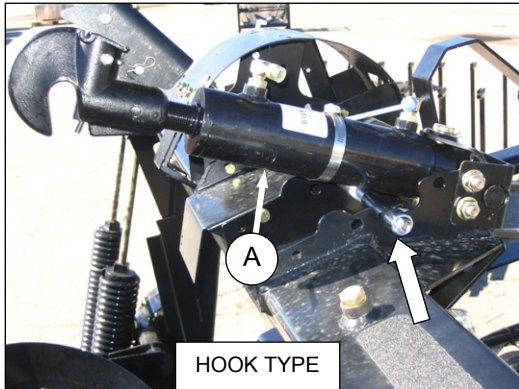

- a. Prop up hydraulic center-link (A) with pin or equivalent tool.



### CAUTION

**Stop engine and remove key from ignition before leaving Operator's seat for any reason. A child or even a pet could engage an idling machine.**

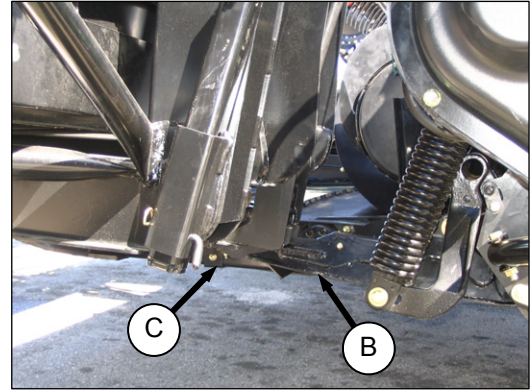

- b. Start engine and lower combine feeder house so that adapter arms (B) are aligned with header balance channel (C). Stop engine and remove key.

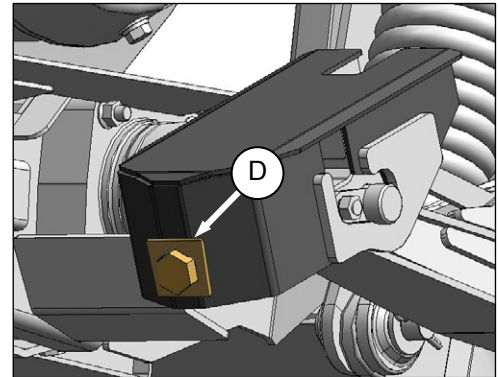

- c. Remove bolts (D), washers, and spacers from adapter legs.
- d. Start engine and slowly drive forward, again aligning adapter arms and header balance channel.
- e. Keep adapter arm height just under the header balance channel to ensure adapter leg seats properly in the header linkage supports.

#### IMPORTANT

Keep hydraulic hoses clear to prevent damage when driving into header.

- f. Continue forward until adapter arm contacts stop in balance channel.

*(continued next page)*

## SECTION 8.2. FD70 FLEXDRAPER AND ADAPTER

- g. Connect **hook type** hydraulic center-link as follows:

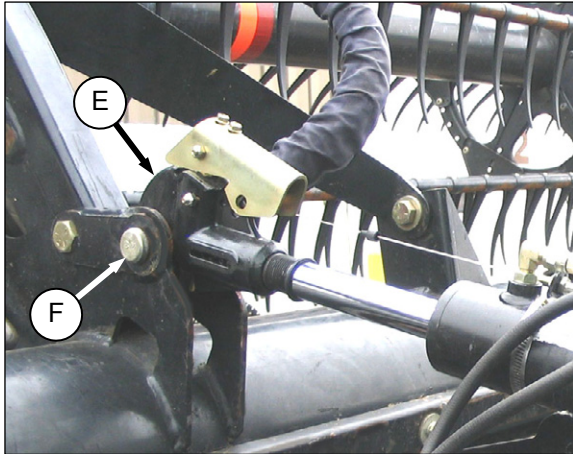

1. Extend hook (E) and remove prop under link so that base of hook rests on pin (F).
2. Operate header angle hydraulics to retract hook until it engages pin and self-latches.



### CAUTION

**Stop engine and remove key from ignition before leaving Operator's seat for any reason. A child or even a pet could engage an idling machine.**

3. Shutdown engine and remove key.
  4. Ensure hook (E) is securely attached.
  5. Proceed to step i.
- h. Connect **eye type** hydraulic center-link as follows:
1. Shutdown engine and remove key.

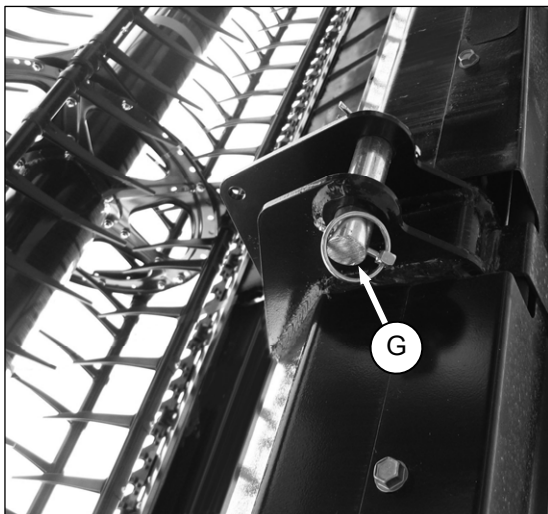

2. Remove pin (G) and the prop under link.

3. Adjust length of link by operating header angle hydraulics to align with header bracket.

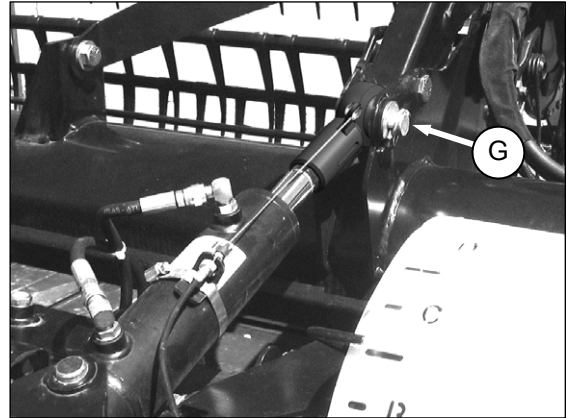

4. Insert pin (G) and secure with lynch pin.

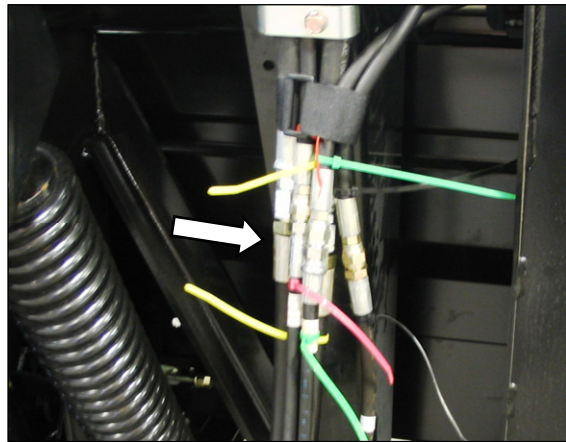

- i. Connect reel hydraulics matching colored plastic ties.
- j. If multi-coupler is installed, connect reel hydraulics as follows:

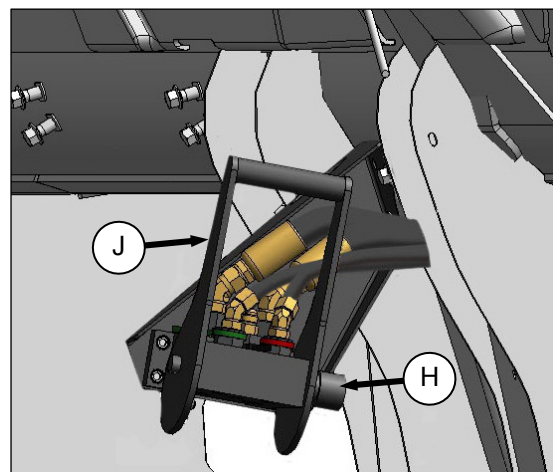

1. Push in lock button (H) and pull handle (J) up to half open position.
2. Clean couplers.

*(continued next page)*



## SECTION 8.2. FD70 FLEXDRAPER AND ADAPTER

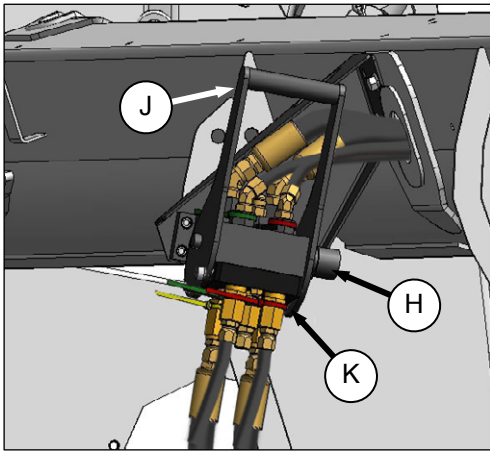

3. Position coupler (K) from adapter onto receptacle and push handle (J) to engage pins on coupler.
4. Push handle to closed position until lock button (H) snaps out.

k. Secure header to adapter as follows:



### CAUTION

**Always connect center-link before fully raising header.**

1. Raise adapter slowly, making sure adapter legs engage in header legs. Raise header fully, stop engine, and remove key.



### DANGER

**To avoid bodily injury or death from fall of raised machine, always engage lift cylinder stops before going under header for any reason. See your Combine Operator's Manual for instructions for use and storage of header lift cylinder stops.**

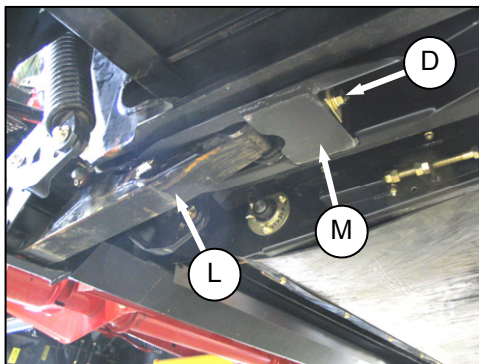

2. Install bolts (D), spacers and lock washers removed at step c. to secure adapter arms (L) to header legs (M).

### IMPORTANT

Do not install bolt longer than 1½ inches (38 mm).

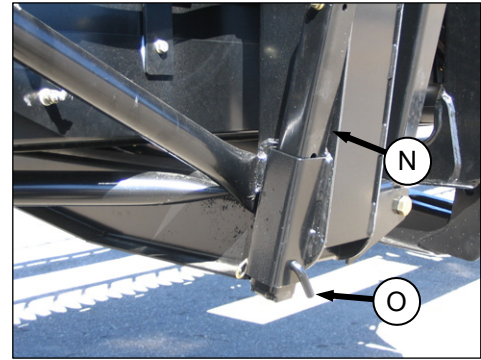

3. Return stand (N) to storage position and secure with pin (O).

### NOTE

*45 foot header does not have a stand.*

- l. Place blocks under center section of header to keep it about 6 inches off the ground.
- m. Adjust header angle to shallowest setting (shortest centre link).
- n. Remove lift cylinder locks and lower header to blocks and allow the header wings to go into full frown mode.
- o. Attach adapter deck to header cutterbar as follows:



### WARNING

**Keep hands clear of the area between guards and sickle at all times.**

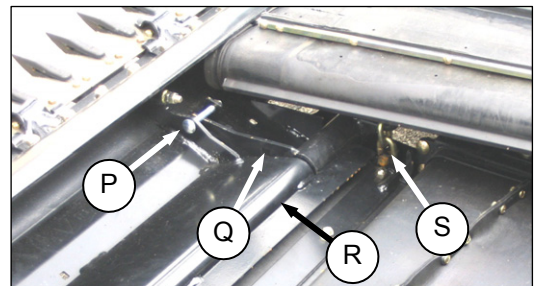
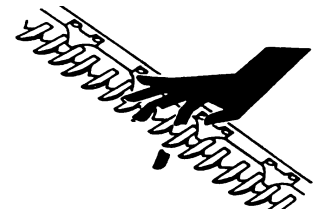

1. If installed, remove bolts (P) at either side of opening to allow attachment of adapter deck.
2. Position latches (Q) on transition pan (R) so that chain (S) can be attached to the latch hook.

*(continued next page)*

## SECTION 8.2. FD70 FLEXDRAPER AND ADAPTER

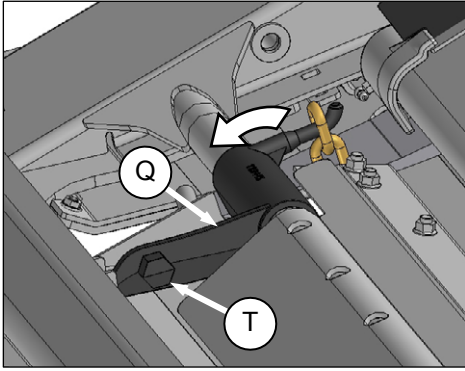

- p. Rotate latch (Q) with a 15/16 wrench (or equivalent) on hex (T) to raise feed deck so that bolt (P) can be reinstalled. Repeat for other side of feed deck.
- q. Attach the wing float linkage to the adapter as follows:

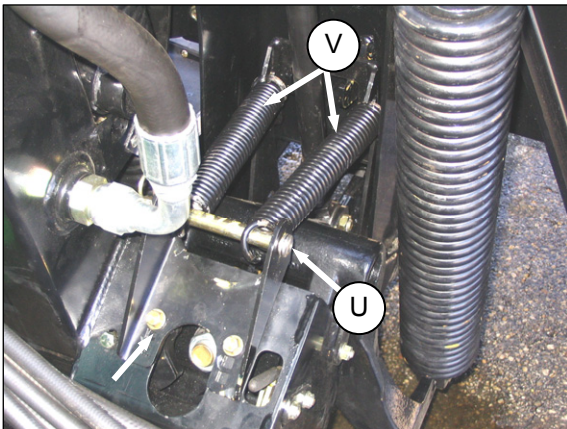

- 1. Remove pin (U) from bracket if installed.
- 2. Reinstall pin with springs (V) and secure with hairpin.

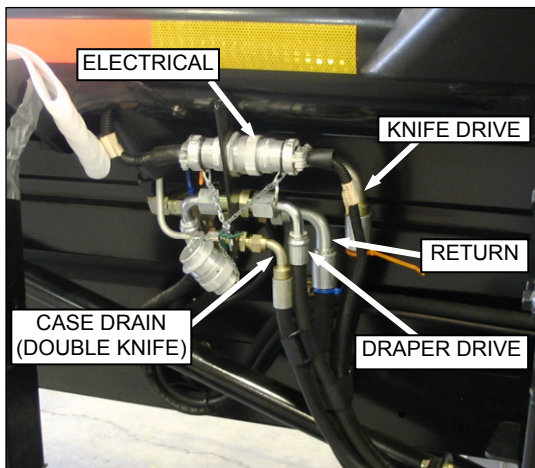

- r. Connect knife and draper drive hydraulics as shown above, matching colored plastic cable ties.

- s. If quick disconnects are installed, connect as follows:

- 1. Remove covers if installed from receptacles and hose ends.
- 2. Check connectors and clean if required.

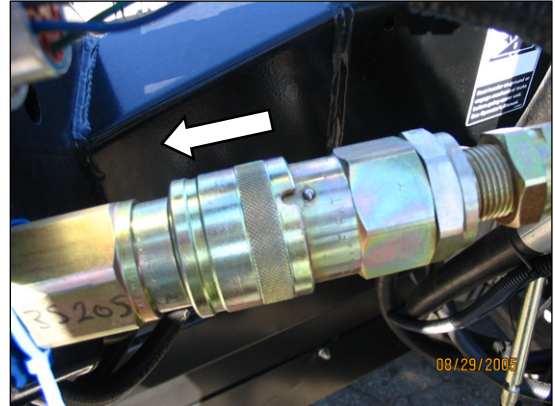

- 3. Push hose connector onto mating receptacle until collar on receptacle snaps into lock position.

### NOTE

*Ensure hoses are clear of driveline and adjacent structure.*

- t. Attach electrical connector as follows:
  - 1. Remove cover on receptacle.
  - 2. Align lugs on connector with slots in receptacle, push connector onto receptacle and turn collar on connector to lock it in place.
  - 3. Attach cover to mating cover on combine wiring harness.
- u. Raise and lower header and reel a few times to allow trapped air to pass back to the reservoir.

### NOTE

*It is not necessary to bleed the system by loosening fittings.*

- v. Check float and if the header is level. If adjustments are required, refer to Section 9.11.3 Header Float, and Section 9.14 HEADER LEVELLING.

## SECTION 9. OPERATION

### 9 OPERATION

#### 9.1 OWNER/OPERATOR RESPONSIBILITIES



#### CAUTION

- It is your responsibility to read and understand this manual completely before operating the header. Contact your MacDon Dealer if an instruction is not clear to you.
- Follow all safety messages in the manual and on safety decals on the machine.
- Remember that YOU are the key to safety. Good safety practices protect you and the people around you.
- Before allowing anyone to operate the header, for however short a time or distance, make sure they have been instructed in its safe and proper use.
- Review the manual and all safety related items with all Operators annually.
- Be alert for other Operators not using recommended procedures or not following safety precautions. Correct these mistakes immediately, before an accident occurs.
- Do not modify the machine. Unauthorized modifications may impair the function and/or safety and affect machine life.
- The safety information given in this manual does not replace safety codes, insurance needs, or laws governing your area. Be sure your machine meets the standards set by these regulations.

#### 9.2 OPERATIONAL SAFETY

Follow these safety precautions:



#### CAUTION

- Follow all safety and operational instructions given in your Operator's Manuals. If you do not have a combine manual, get one from your MacDon Dealer and read it thoroughly.
- Never attempt to start the engine or operate the machine except from the combine seat.
- Check the operation of all controls in a safe clear area before starting work.
- Do not allow riders on combine.



- Never start or move the machine until you are sure all bystanders have cleared the area.

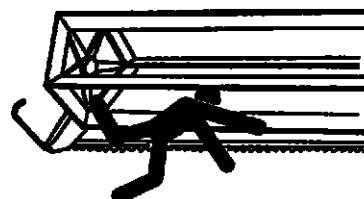

- Avoid travelling over loose fill, rocks, ditches or holes.
- Drive slowly through gates and doorways.
- When working on inclines, travel uphill or downhill when possible. Be sure to keep transmission in gear when travelling downhill.



## SECTION 9. OPERATION

- Never attempt to get on or off a moving machine.
- Do not leave Operator's station while the engine is running.
- Stop engine and remove key before adjusting or removing plugged material from the machine. A child or even a pet could engage the drive.
- Check for excessive vibration and unusual noises. If there is any indication of trouble, shut down and inspect the machine. Follow proper shutdown procedure. Refer to Section 9.6 SHUTDOWN PROCEDURE.
- Operate only in daylight or good artificial light.

### 9.3 BREAK-IN PERIOD

- a. After attaching header to combine for the first time, operate the machine with reel drapers and sickle running slowly for 5 minutes, watching and listening FROM THE OPERATOR'S SEAT for binding or interfering parts.

#### NOTE

*Reel and side drapers will not operate until oil flow fills the lines.*



### CAUTION

**Before investigating an unusual sound or attempting to correct a problem, shut off engine, and remove key.**

- b. Perform the items specified in 10.17.1 Break-In Inspections.

#### NOTE

*Until you become familiar with the sound and feel of your new header, be extra alert and attentive.*

### 9.4 PRE-SEASON CHECK

Perform the following the beginning of each operating season:



### CAUTION

- Review the Operator's Manual to refresh your memory on safety and operating recommendations.
  - Review all safety decals and other decals on the header and note hazard areas.
  - Be sure all shields and guards are properly installed and secured. Never alter or remove safety equipment.
  - Be sure you understand and have practiced safe use of all controls. Know the capacity and operating characteristics of the machine.
  - Check the first aid kit and fire extinguisher. Know where they are and how to use them.
- a. Adjust tension on drive belts. Refer to Sections 10.11.8 Sickle Drive Belts - Non-Timed Drive, and 10.11.9 Double Knife Drive Belts - Timed Drive.
  - b. Perform all annual maintenance. See Section 10.17 MAINTENANCE SCHEDULE.

## SECTION 9. OPERATION

### 9.5 DAILY START-UP CHECK

Do the following each day before start-up:



#### CAUTION

- Clear the area of other persons, pets etc. Keep children away from machinery. Walk around the machine to be sure no one is under, on, or close to it.
- Wear close fitting clothing and protective shoes with slip resistant soles.
- Remove foreign objects from the machine and surrounding area.
- As well, carry with you any protective clothing and personal safety devices that **COULD** be necessary through the day. Don't take chances.
- You may need:

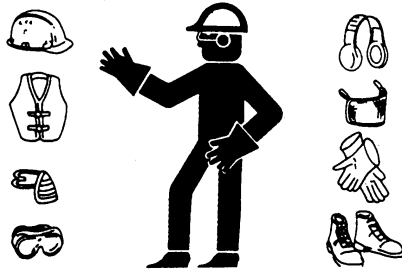

- a hard hat
- protective glasses or goggles
- heavy gloves
- respirator or filter mask
- wet weather gear
- Protect against noise. Wear a suitable hearing protective device such as ear muffs or ear plugs to protect against objectionable or uncomfortable loud noises.



- a. Check the machine for leaks or any parts that are missing, broken, or not working correctly.

#### NOTE:

*Use proper procedure when searching for pressurized fluid leaks. Refer to Section 10.6 HYDRAULICS.*

- b. Clean all lights and reflective surfaces on the machine.
- c. Perform all Daily maintenance. Refer to Section 10.17 MAINTENANCE SCHEDULE.

### 9.6 SHUTDOWN PROCEDURE



#### CAUTION

Before leaving the combine seat for any reason:

- Park on level ground if possible.
- Lower the header fully.
- Place all controls in NEUTRAL or PARK.
- Disengage header drive.
- Stop engine and remove key from ignition.
- Wait for all movement to stop.

## SECTION 9. OPERATION

### 9.7 HEADER CONTROLS



#### CAUTION

Be sure all bystanders are clear of machine before starting engine or engaging any header drives.

See your Combine Operator's Manual for identification of in-cab controls for:

- Header Drive Clutch
- Header Height
- Header Angle
- Ground Speed
- Reel Speed
- Reel Height
- Reel Fore-Aft Position

### 9.8 HEADER LIFT CYLINDER LOCK-OUTS



#### DANGER

To avoid bodily injury or death from fall of raised machine, always engage lift cylinder stops before going under header for any reason. See your Combine Operator's Manual for instructions for use and storage of header lift cylinder stops.

**THE CONTENT ON THIS PAGE HAS CHANGED SINCE THIS MANUAL (169006 REVISION C) WAS PUBLISHED.**

### 9.9 REEL PROPS



#### WARNING

To avoid bodily injury from fall of raised reel, always engage reel props before going under raised reel for any reason.

#### IMPORTANT

To prevent damage to reel support arms, do not transport header with reel props engaged.

Reel props are located at each reel support arm. To engage reel props, proceed as follows:

1. Raise the reel fully.
2. Shut down the engine, and remove the key from the ignition.
3. Move reel safety props (A) to the engaged position (as shown). **The prop MUST be placed on the top surface of raised lug (B), making contact with the cylinder mount, to ensure positive engagement.**

**NOTE:** Keep pivot bolt (C) sufficiently tight so that the prop remains in the stored position when not in use, but can still be engaged using hand force.

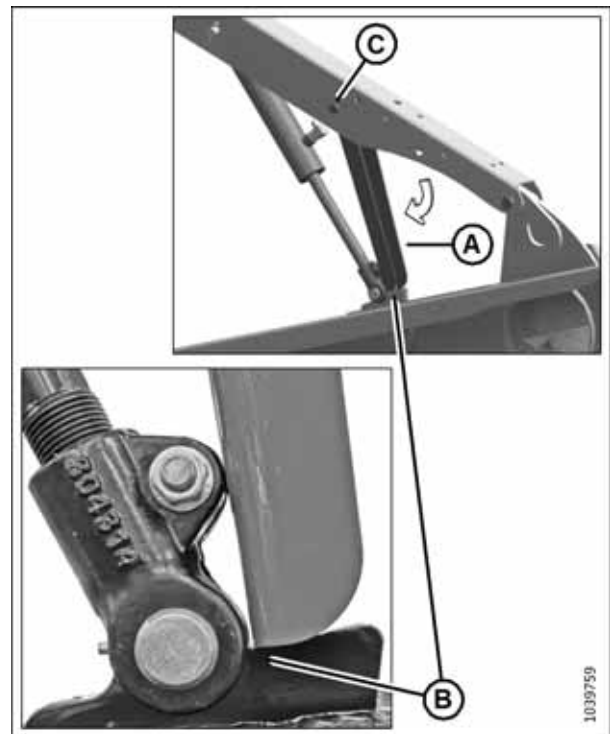

Reel Safety Prop – Left Arm Shown



## SECTION 9. OPERATION

4. Repeat the procedure on the opposite side of the header.
5. **Double-reel headers:** Use handle (A) to move the lock rod to inboard position (B) which engages pin (C) under the prop.
6. **Double-reel headers:** Lower the reel until the safety props contact the outer arm cylinder mounts and the center arm pins.

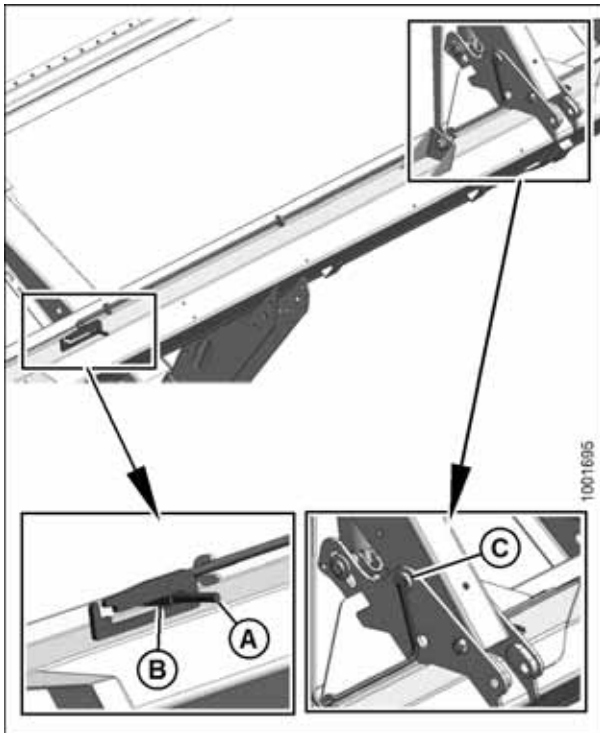

Reel Safety Prop – Center Arm

7. To disengage reel props, raise reel, push outside arm props (A) back against reel arm.
8. For double reel headers, move lock (C) to outboard position.

**THE CONTENT ON THIS PAGE  
HAS CHANGED SINCE THIS  
MANUAL (169006 REVISION C)  
WAS PUBLISHED.**

## SECTION 9. OPERATION

### 9.10 STORAGE

Do the following at the end of each operating season:

- a. Clean the header thoroughly.



#### CAUTION

**Never use gasoline, naphtha or any volatile material for cleaning purposes. These materials may be toxic and/or flammable.**



#### CAUTION

**Cover cutterbar and sickle guards to prevent injury from accidental contact.**

- b. Store the machine in a dry, protected place if possible. If stored outside, always cover with a waterproof canvas or other protective material.
- c. If machine is stored outside, remove drapers and store in a dark, dry place.

#### NOTE:

*If drapers are not removed, store header with cutterbar lowered so water/snow will not accumulate on drapers. This accumulation of weight puts excessive stress on drapers and header*

- d. Lower header onto blocks to keep cutterbar off the ground.
- e. Lower reel completely. If stored outside, tie reel to frame to prevent rotation caused by wind.
- f. Repaint all worn or chipped painted surfaces to prevent rust.
- g. Loosen drive belts.
- h. Lubricate the header thoroughly, leaving excess grease on fittings to keep moisture out of bearings. Apply grease to exposed threads, cylinder rods and sliding surfaces of components. Oil sickle components to prevent rust.
- i. Check for worn or broken components and repair or order replacement from your MacDon Dealer. Attention to these items right away will save time and effort at beginning of next season.
- j. Replace or tighten any missing or loose hardware. Refer to Section 10.3.1 Recommended Torques.

## SECTION 9. OPERATION

### 9.11 HEADER SET-UP

The following table is included as a guideline for setting the pickup reel and the header. Settings other than those suggested can be made to suit various crops and conditions not covered in the table.

To use the table, proceed as follows:

1. Determine crop type to be cut.
2. Determine desired stubble length.
3. Determine condition of the crop.
4. Locate the most suitable set-up for the reel.
5. Refer to chart that starts on the next page for reel settings.

**Example shown:** In Table - Canola, leave long stubble, heavy crop. Select set-up B. In Reel Settings Chart (next page) - set cam at 2; position reel at 3 or 4, and cut with varying header angles to suit varying crop conditions.

CROP TYPE	STUBBLE	RECOMMENDED MACHINE SET-UP				SEE NOTES BELOW
		CROP CONDITION				
		LIGHT	NORMAL	HEAVY	LODGED	
Cereals	4" - 8"	E	A	B	D or G	a, b, c, d
	10"+	F	A	B	D or G	a, b, c, d
	Ground	C	A	A	A	a
Alfalfa	4" - 8"	E	A	A or C	---	a
<b>Canola</b>	10"+	F	A	<b>B or H</b>	D	a, b, d
Grass	Ground	A	A or J	J	---	a
Rice	10"+	F	A	G	G	a, b, c, d

**Notes:**

- a. Adjust reel forward to get closer to ground when tilting header back. Fingers/Tines will dig into ground at extreme reel forward positions so adjust skid shoes or header angle to compensate. Adjust reel rearward to get reel further away from ground when tilting header forward.
- b. Header tilt can be increased to get reel closer to ground or decreased to get reel further away from ground while keeping material flowing onto drapers.
- c. To leave maximum amount of stubble behind in lodged crop, raise header but increase header tilt to keep reel close to ground. Position reel fully forward.
- d. Reel may have to be moved back to prevent lumps or plugging on cutterbar in thinner crops.
- e. Minimum crop carrying capacity (minimum area of exposed draper between reel and header backsheet) occurs with the reel in the furthest aft position.
- f. Maximum crop carrying capacity (maximum area of exposed draper between reel and header backsheet) occurs with the reel in the furthest forward position.
- g. The tip speed of the fingers/tines at the cutterbar becomes higher than the reel speed at higher cam settings due the nature of the cam action. Refer to Reel Settings Chart that starts on the next page.

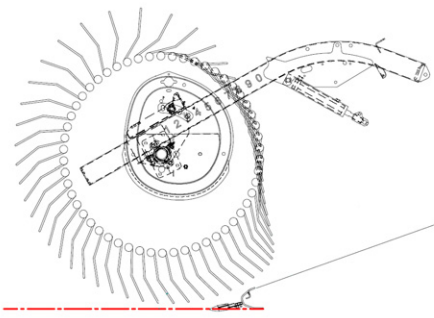
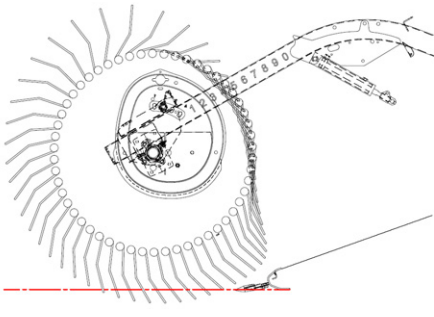
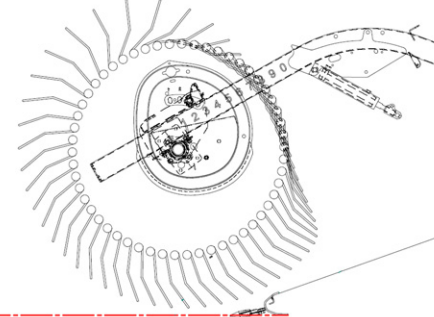
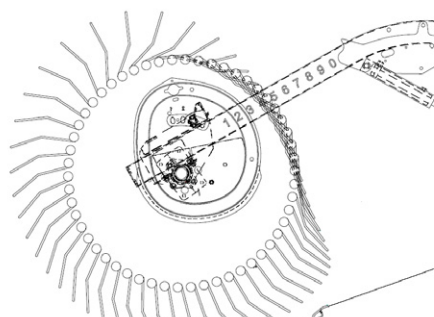

## SECTION 9. OPERATION

REEL SETTING REFERENCE	CAM SETTING NUMBER (Finger Speed Gain)	REEL POSITION NUMBER	HEADER ANGLE	REEL FINGER PATTERN
<b>A</b>	<b>2</b> (20%)	<b>6 or 7</b>	<b>Middle</b>	
<b>B</b>	<b>2</b> (20%)	<b>3 or 4</b>	<b>Variable</b>	
<b>C</b>	<b>3</b> (30%)	<b>6 or 7</b>	<b>Middle</b>	
<b>D</b>	<b>3</b> (30%)	<b>3 or 4</b>	<b>Variable</b>	

## SECTION 9. OPERATION

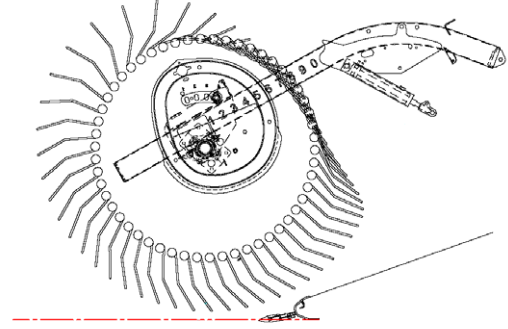
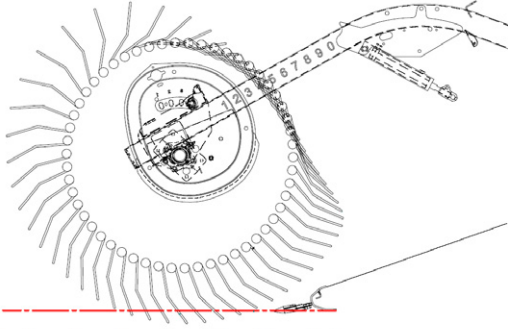
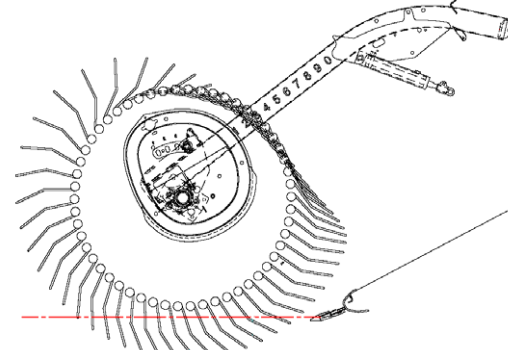
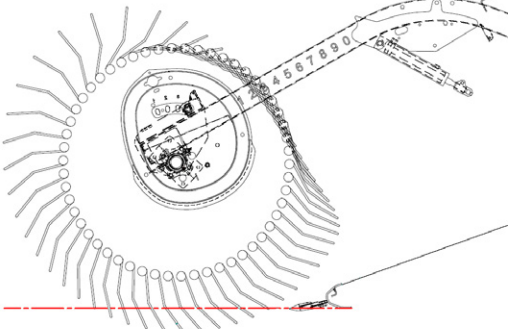
REEL SETTING REFERENCE	CAM SETTING NUMBER (Finger Speed Gain)	REEL POSITION NUMBER	HEADER ANGLE	REEL FINGER PATTERN
<b>E</b>	<b>4</b> <b>(35%)</b>	<b>6 or 7</b>	<b>Middle</b>	
<b>F</b>	<b>4</b> <b>(35%)</b>	<b>2 or 3</b>	<b>Variable</b>	
<b>G</b>	<b>4</b> <b>(35%)</b>	<b>1</b>	<b>Maximum</b>	
<b>H</b>	<b>4</b> <b>(35%)</b>	<b>1</b>	<b>Variable</b>	

## SECTION 9. OPERATION

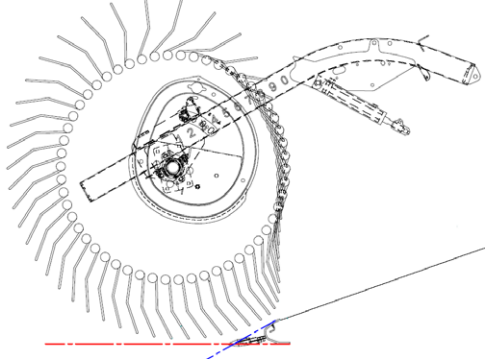
REEL SETTING REFERENCE	CAM SETTING NUMBER (Finger Speed Gain)	REEL POSITION NUMBER	HEADER ANGLE	REEL FINGER PATTERN
<b>J</b>	<b>1 (0)</b>	<b>6 or 7</b>	<b>Middle</b>	



## SECTION 9. OPERATION

### 9.11.1 HEADER OPERATING VARIABLES

Satisfactory function of the header in all situations requires making proper adjustments to suit various crops and conditions.

Correct operation reduces crop loss and allows cutting of more acres. As well, proper adjustments and timely maintenance will increase the length of service you receive from the machine.

The variables listed below and detailed on the following pages will affect the performance of the machine. You will quickly become adept at adjusting the machine to give you the desired results.

VARIABLE	SECTION
Cutting Height	9.11.2
Header Float	9.11.3
Header Angle	9.11.4
Reel Speed	9.11.5
Ground Speed	9.11.6
Draper Speed	9.11.7
Knife Speed	9.11.8
Reel Height	9.11.9
Reel Fore-Aft Position	9.11.10
Reel Tine Pitch	9.11.11
Crop Dividers and Rods	9.11.12

### 9.11.2 CUTTING HEIGHT

The D and FD Series of draper headers are designed to allow an Operator to cut the crop above the ground for a desired stubble height, or to cut the crop at ground level with the header on the ground. Cutting height will vary, depending on factors including whether windrowing or straight-cutting, type of crop, etc.

#### 9.11.2.1 Cutting Off The Ground

Cutting height is controlled with a combination of header lift cylinder adjustment and a stabilizer wheel system or a stabilizer/slow speed transport wheel system. Both systems are only available on 30, 35, 40, and 45 foot headers.

The stabilizing wheel system in both options is designed to minimize bouncing at the header ends, and may be used to “float” the headers to achieve an even cutting height when cutting above ground level in cereal grains.

The system can provide very even stubble height and greatly reduced operator fatigue.

The proper setting requires ‘balancing’ the amount of header weight carried by the main float and the stabilizer wheels.



### CAUTION

**Stop engine and remove key from ignition before leaving Operator’s seat for any reason. A child or even a pet could engage an idling machine.**

- Raise the header so that the stabilizer wheels are off the ground. Shutdown engine and remove the key.
- Check that the main float is working properly. See Section 9.11.3 Header Float.
- Set up the stabilizer wheels, if installed, as follows: Otherwise, proceed to step d.

### IMPORTANT

Do not use the stabilizer wheel system for header height control if your header was manufactured prior to 2007. This would result in damage to the wheel suspension system.



### CAUTION

**Handle may be under tension, especially when the wheels are on the ground. Raise header so that wheels are off the ground before making adjustments.**

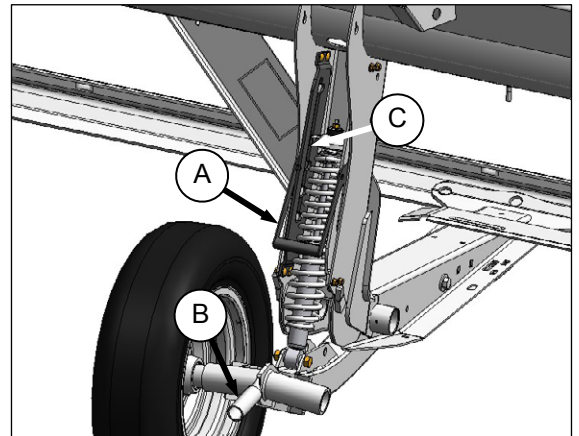

LH SHOWN - RH OPPOSITE

- Support wheel weight by lifting slightly with one hand on handle B. Pull up on handle (A) to release lock.
- Lift wheel with handle (B) to and engage support channel into center slot (C) in upper support.
- Push down on handle (A) to lock.

*(continued next page)*

## SECTION 9. OPERATION

4. Lower header to desired cutting height using combine controls, and check spring length as shown. Readjust wheels as required to achieve range.

### IMPORTANT

Continuous operation with excessive spring compression (i.e. spring length shorter than 12.6 in +/-1.0 (320 mm +/-25)) can result in damage to the suspension system.

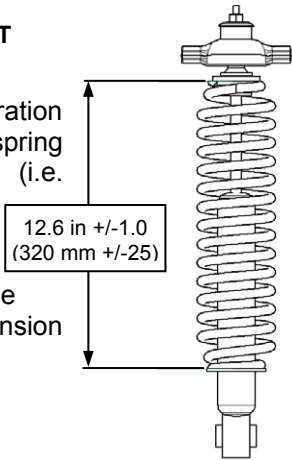

- d. Set up the stabilizer/slow speed transport wheels, if installed, as follows: Otherwise, proceed to step e.

1. Adjust right wheels as follows:

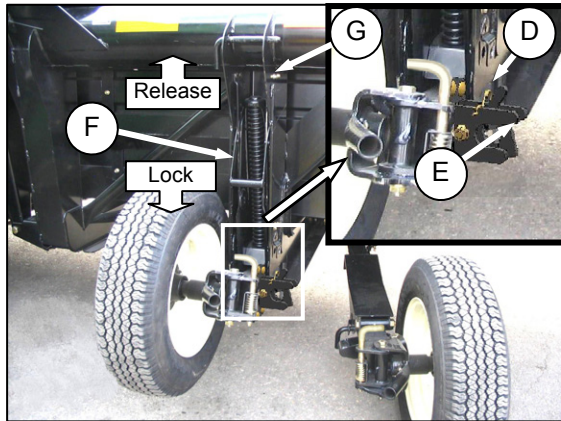

TRANSPORT TO FIELD - RH SIDE

- i. Remove hairpin (D) from latch.
- ii. Disengage latch (E) and lift right wheel out of hook and place on ground as shown. This reduces weight of assembly and makes adjusting wheel position easier.
- iii. Support left wheel weight by lifting slightly with one hand. Pull up on handle (F) to release lock.
- iv. Lift left wheel to desired height and engage support channel into slot (G) in upper support.
- v. Push down on handle (F) to lock.
- vi. Lift right hand wheel back into field position and ensure latch (E) is engaged.
- vii. Secure latch with hairpin (D).

2. Adjust left wheels as follows:

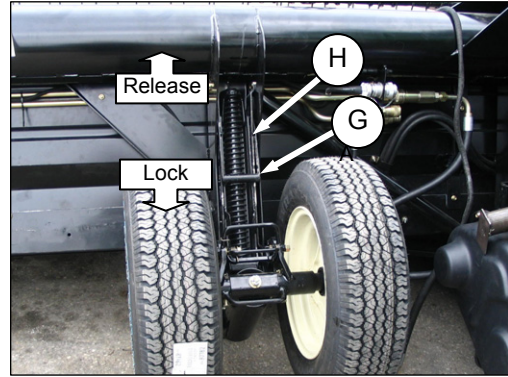

- i. Support wheel weight by lifting slightly with one hand. Pull up on handle (G) to release lock.
- ii. Lift wheels to desired height and engage support channel into slot (H) in upper support.
- iii. Push down on handle (G) to lock.
- iv. Lower header to desired cutting height using combine controls, and check load indicator as shown below. Readjust wheels as required to achieve range between 2 and 3 as shown.

### IMPORTANT

Continuous operation with excessive spring compression (i.e. load indicator reading greater than #4) can result in damage to suspension system.

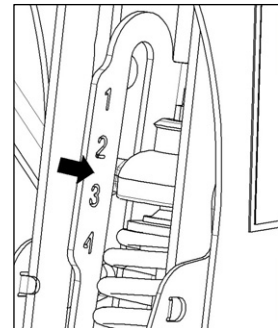

- e. Adjust header angle to desired working angle with the machines' header angle controls. If angle is not critical, set it to mid-position.
- f. Use the combine AHHC to automatically maintain cutting height. Refer to your combine Operator's Manual and AHHC instructions for details.

### NOTE

*Header angle adjustments or AHHC ground pressure control may be used for "on-the-go" cut height adjustments.*

## SECTION 9. OPERATION

### 9.11.2.2 Cutting On The Ground

Cutting on the ground is controlled with a combination of skid shoes, header angle, and float adjustment, and **not** with the header lift cylinders.

Having the header "ride" on the skid shoes allows the float linkage to float the header over obstacles and follow ground contours, rather than supporting the header with the cylinders.

Lowering the skid shoes or decreasing the header angle increases the cutting height. This may be desirable in stony conditions, to reduce damage to cutting components. Also, a longer stubble length helps material dry faster.

Raising the skid shoes and increasing the header angle allows the crop to be "shaved".

Set up the header as follows:

1. Fully raise the stabilizer wheels, or slow speed transport wheels if installed. Refer to previous section.



### DANGER

**To avoid bodily injury or death from unexpected start-up or fall of raised machine, stop engine, remove key and engage lift cylinder stops before going under machine to adjust skid shoes or for any reason.**

2. Fully raise header, engage lift cylinder stops, shutoff engine and remove key.
3. Adjust skid shoes to achieve desired cutting height as follows:

#### Outer Skid Shoes

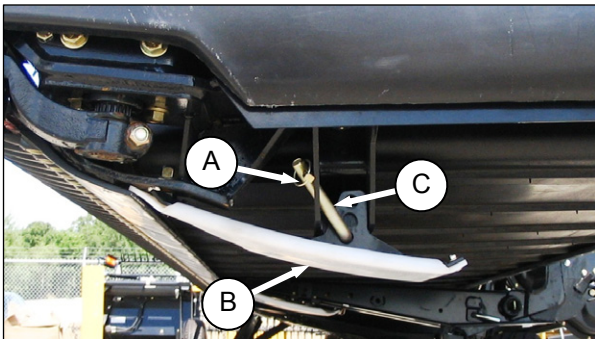

1. Remove lynch pin (A) at each skid shoe (B).
2. Hold shoe and remove pin (C) by disengaging frame and then pulling away from shoe.
3. Raise or lower skid shoe to desired position using holes in support as a guide.

4. Reinstall pin (C), engage in frame, and secure with lynch pin (A).

#### Inner Skid Shoes

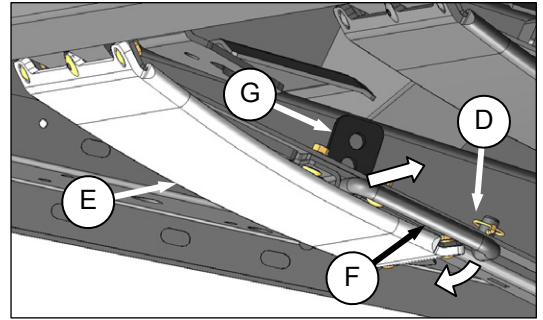

1. Remove lynch pin (D).
2. Hold shoe (E) and remove pin (F) by pulling down to disengage frame and then pulling away from shoe.
3. Raise or lower skid shoe (E) to desired position using holes in support (G) as a guide.

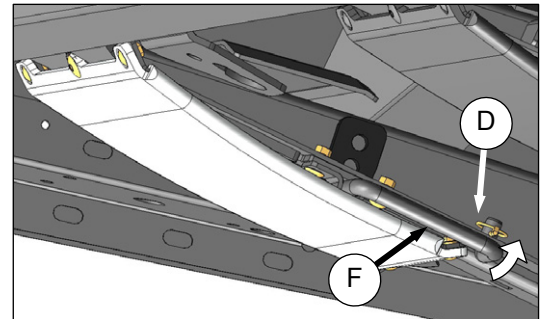

4. Reinsert pin (F), engage in frame, and secure with lynch pin (D).
- d. Check that skid shoes are adjusted to the same position.
- e. Adjust header angle to desired working position using the machines' header angle controls. If angle is not critical, set it to mid-position.
- f. Check header float as described in the following Section 9.11.3 Header Float.



## SECTION 9. OPERATION

### 9.11.3 HEADER FLOAT

D50, D60, and FD70 combine headers perform best with minimum extra weight on the header, under normal conditions.

Check the float as follows:

#### 9.11.3.1 Main Float Locks

The function of the header main float locks are to lock and unlock the header float system.

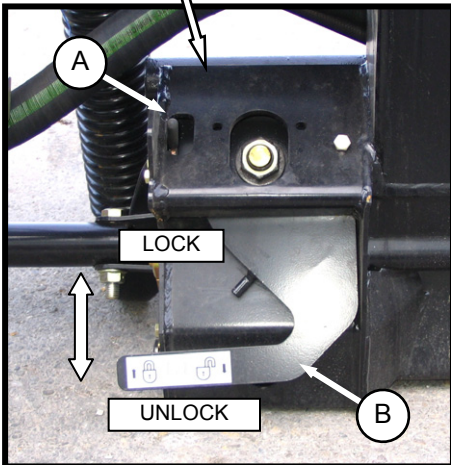
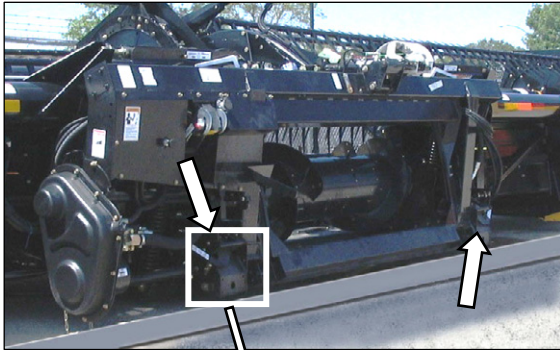

There are two locks - one on each side of the adapter.

#### IMPORTANT

The main float locks must be engaged when the header is being transported with the adapter attached so there is no relative movement between the adapter and header during transport.

The float locks must also be locked during detachment from the combine to allow the feeder house to release the adapter.

- Disengage main float locks by moving latch (A) away from adapter and moving lever (B) at each lock to lowest position. In this position, the header is unlocked and can float with respect to the adapter.
- Engage the main float locks by moving lever (B) up to its highest position. In this position, the header cannot move with respect to the adapter.

#### 9.11.3.2 Checking and Adjusting Float



### CAUTION

Stop engine and remove key from ignition before leaving Operator's seat for any reason. A child or even a pet could engage an idling machine.

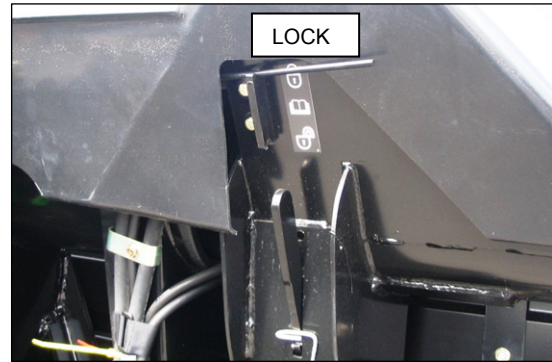

- If adjusting FD70 FlexDraper header main float, ensure both wing float locks are engaged.

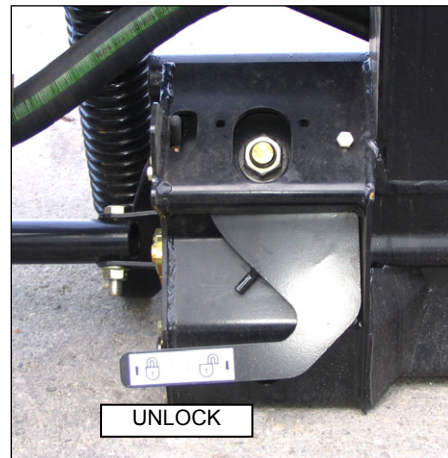

- Ensure both header float lock levers are down (UNLOCK).

*(continued next page)*



## SECTION 9. OPERATION

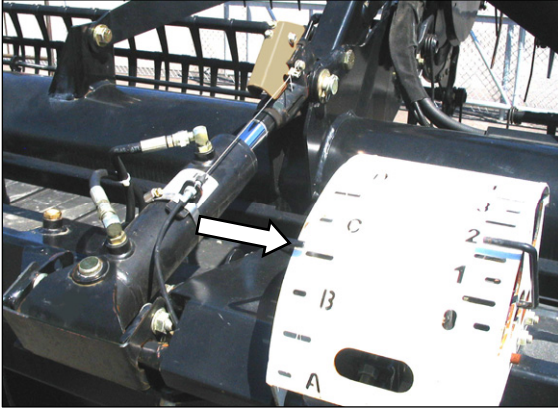

- c. Set center-link to mid-range (B to C on float/angle indicator if installed). Adjust cutterbar to 6 - 10 inches (150 - 250 mm) above the ground.
- d. If header is equipped with stabilizer wheels or slow speed transport wheels, raise them off the ground so they are supported by the header.

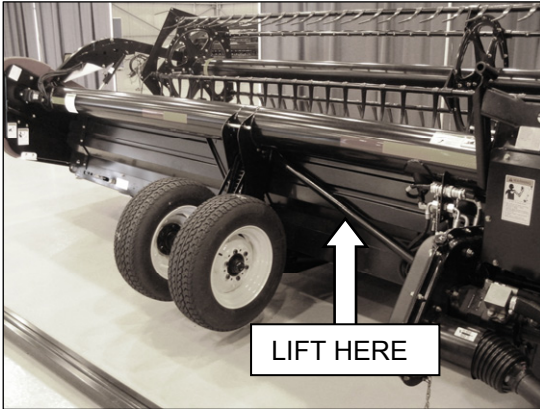

- e. Lift the header at the rear diagonal brace, or on the back-tube. The lifting force should meet the following criteria:
  - If header will be operating with the cutterbar on the ground, the header should move up with approximately 75 lbf (334 N) force and then return to its original position.
  - If header will be mostly operating with the cutterbar off the ground, the float should be set heavier to minimize bouncing of the header.

Also see "IMPORTANT" notes in the opposite column.

### NOTE

Check movement of bellcranks at base of adapter. They should move forward when the header is lifted and then return to the original position.

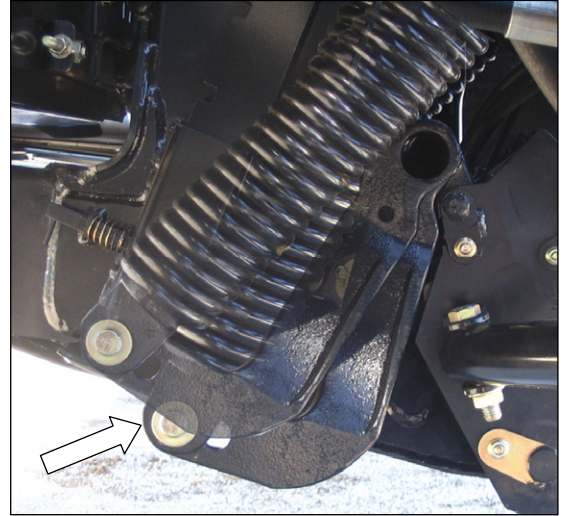

- f. If excessive force is required, or the header does not return to its original position, the float requires adjusting. Refer to following Sections: 9.11.3.3 Adjusting Header Float - Normal, or 9.11.3.4 Adjusting Header Float - Cutterbar On Ground.

### IMPORTANT

To avoid frequent breakage of sickle components, scooping soil, or soil build-up at cutterbar in wet conditions, header float should be set as light as possible without causing excessive bouncing. When float setting is light, it may be necessary to use a slower ground speed to avoid excessive bouncing and leaving a ragged cut.

### IMPORTANT

The stabilizer wheels may be used in conjunction with main float to minimize bouncing at the header ends and control cut height when cutting off the ground. Refer to Section 9.11.2 Cutting Height for details.

### NOTE

If adequate header float cannot be achieved using all of the available adjustments, an optional heavy duty spring is available. It includes an inner spring. See your MacDon Dealer or Parts Catalog for ordering information.

## SECTION 9. OPERATION

### 9.11.3.3 Adjusting Header Float - Normal

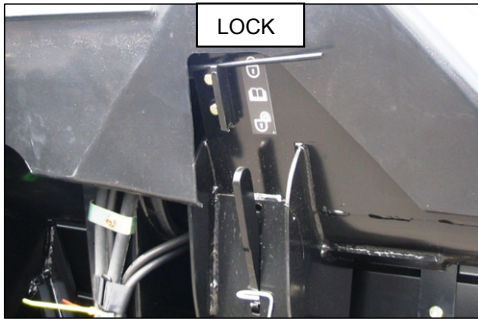

- a. If adjusting FD70 FlexDraper header float, ensure both wing float locks are engaged.

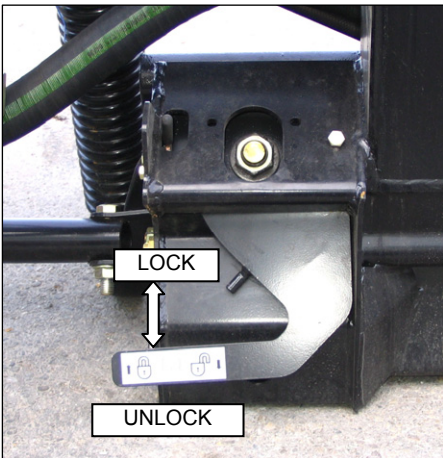

- b. Ensure both header float lock levers are down (UNLOCK).

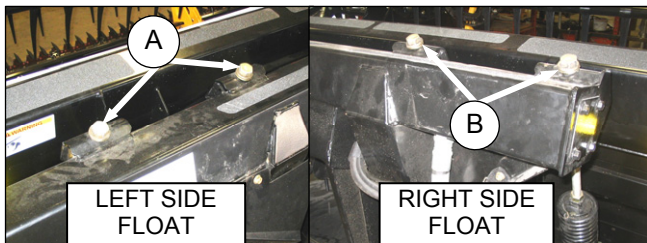

- c. Tighten bolts (A) and (B) at both sides of adapter to increase float (lightens the header).  
 d. Loosen bolts to decrease float (increases header weight).

#### IMPORTANT

Turn each bolt pair equal amounts.

- e. The float is properly adjusted when:
- for **30, 35, and 40 foot single knife**: Both sides of the header are adjusted to the same weight (approximately 75 lbf (334 N)).
  - for **40 and 45 foot double knife**: RH side is slightly heavier (loosen RH side adjuster bolts (B) by 2 turns).

#### IMPORTANT

Proper float adjustment in accordance with the above is critical to maintain proper wing balance when cutting on the ground.

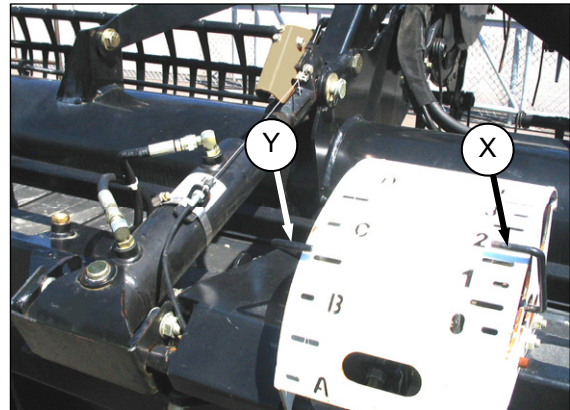

- f. Adjust feeder house height while watching float indicator (X) to set cutterbar down force (normally 2 on indicator). Lower feeder house height to increase ground pressure (decrease float). Indicator reading will increase.

#### NOTE

*Installation of the auto header height controller attachment is recommended for cutting on the ground if the combine is equipped to interface with it.*

- g. When cutting on ground, adjust header angle to achieve desired stubble height. AHHC (Y) indicates A for shallowest angle/higher stubble, and D for steepest angle/lower stubble.  
 h. In rocky fields, adjust skid shoes down to raise guards when operating at flattest header angle to minimize scooping rocks.  
 i. Increase header height or decrease header angle to minimize pushing soil.

#### NOTE

*Header angle and reel fore-aft position changes do not significantly affect header float (down force).*



## SECTION 9. OPERATION

### 9.11.3.4 Adjusting Header Float - Cutterbar on Ground

When operating with the cutterbar on the ground and with the wings unlocked, one wing may tend to smile while the other may tend to frown.

If the wing balance is set per Section 10.15.2 Wing Balance, check that the main float is set as per Section 9.11.3.3 Adjusting Header Float - Normal.

If that does not solve the problem, proceed as follows:

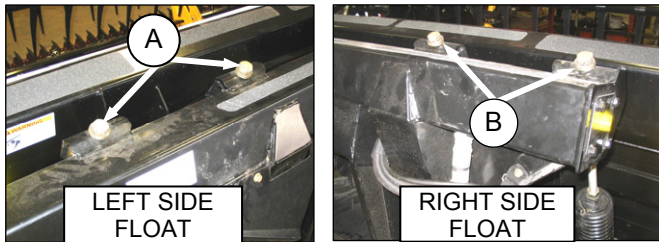

- If the LH wing tends to smile and the RH tends to frown:** make the LH main float heavier by turning bolts (A) on the left side main float spring out 1 or 2 turns. Repeat until both wings tend to move up or down equally when moving across the field.
- If the RH wing tends to smile and the LH wing tends to frown:** make the RH main float heavier by turning bolts (B) on the right side main float spring out 1 or 2 turns. Repeat until both wings tend to move up or down equally when moving across the field.

#### NOTE:

*Loosening the bolts increases header weight and decreases float.*

*Tightening the bolts lightens the header and increases float.*

#### IMPORTANT

Turn each bolt pair equal amounts.

### 9.11.3.5 Wing Float Lock - FD70

The FD70 FlexDraper is designed to operate with the cutterbar on the ground. The three (3) sections move independently to follow the ground contours. In this mode, the wing float lock is **unlocked**.

The FlexDraper can also be operated as a rigid header with the cutterbar straight. A typical application is in cereals when cutting above the ground. In this mode, the wing float lock is **locked**.

Lock and unlock wing float as follows:

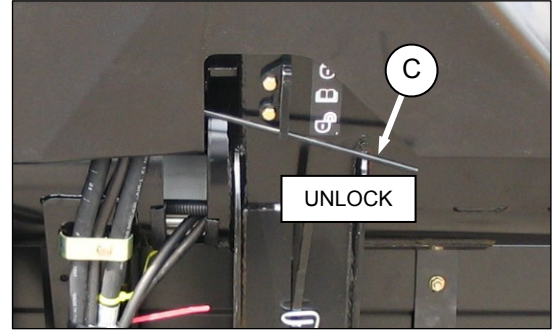

- To operate with wing float, place spring handle (C) in the lower slot to unlock.
- To operate without wing float (rigid cutterbar), place spring handle (C) in the upper slot to lock.

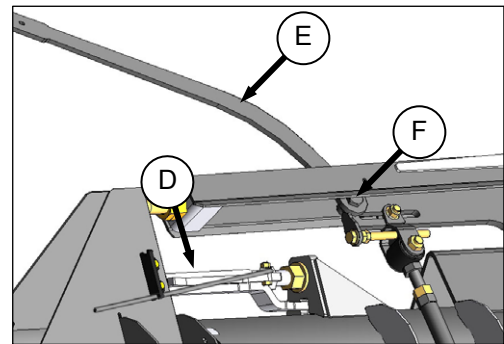

- If the lock link (D) does not disengage, raise and lower the header, change the header angle, or drive the combine to cause wing movement which should cause it to disengage.
- The wing can also be moved by using the supplied wrench (E), and applying torque on bolt (F). The wrench is stored in the header leg, just below the wing float lock.

### 9.11.3.6 Wing Float Linkage Adjustments

The wing float has been adjusted at the factory but the following adjustments may be necessary for optimum operation of the FD70 FlexDraper:

- Wing Balance
- Cutterbar Straightness In Lock Mode
- Wing Flex Range

Refer to Section 10.15 HEADER WING FLOAT for details on performing these adjustments.



## SECTION 9. OPERATION

### 9.11.4 HEADER ANGLE

Header angle is the angle between the drapers and the ground, and is adjustable to accommodate crop conditions and/or soil type.

Guard angle is the similar to header angle which is the angle between the guard upper surface and the ground. Refer to illustration.

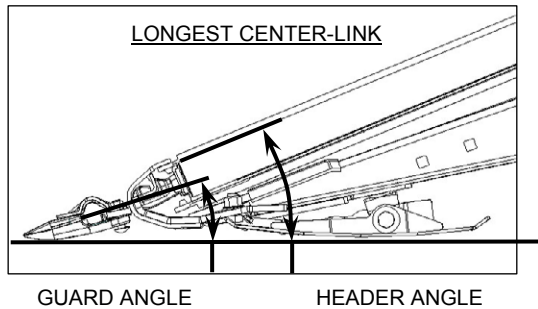
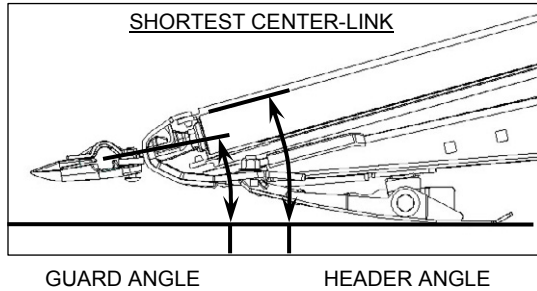

Flatter header angles are recommended for normal crop conditions and for stony ground because it minimizes sickle section breakage and reduces soil scooping or build-up at the cutterbar in wet conditions.

Steeper angles are recommended in “downed” crops for better lifting action, or for cutting close to the ground in soybeans for example.

Refer to Section 9.11.11 Reel Tine Pitch and Section 9.11.10 Reel Fore-Aft Position for adjustment details.

The following table summarizes the adjustment range:

HEADER WIDTH	DRAPER ANGLE	GUARD ANGLE
25 FOOT	13.0° - 18.4°	7.0° - 12.4°
30 FOOT	13.0° - 18.4°	2.0° - 7.4°
35 FOOT	13.0° - 18.4°	2.0° - 7.4°
40 FOOT	13.0° - 18.4°	2.0° - 7.4°
45 FOOT	13.0° - 18.4°	2.0° - 7.4°

#### 9.11.4.1 Angle Adjustment

The header angle is varied by adjusting the length of the top center-link (mechanical or hydraulic) between the combine adapter and the header.

Refer to “Header Angle” in your Combine Operator’s Manual for adjustment details.

## SECTION 9. OPERATION

### 9.11.5 REEL SPEED

Reel speed affects feeding of crop into the sickle and onto the drapers, as well as the smoothness and evenness of the delivered crop.

Operating the reel too fast or too slow relative to ground speed will cause bunching. At the proper speed, the reel discs should appear to be being driven by the ground.

- If they look like they are skidding relative to ground, the reel is turning too slow.
- If they look like they are spinning excessively relative to the ground, reel speed may be too fast.

In standing crop, reel speed should be just faster than or equal to ground speed, sweeping crop across the sickle.

Flattened crop or a crop that is leaning away from the cutterbar requires a higher reel speed in relation to ground speed. This can be achieved by increasing reel speed, decreasing ground speed, or both.

Excessive shattering of grain heads or crop loss over the header back tube may be indications that reel speed is too fast. Excessive reel speed causes undue wear of reel components and unnecessary load on reel drive, resulting in uneven reel motion.

Generally, 9-bat reels can effectively operate at lower reel speed, while minimizing crop loss in shatter prone crops.

The reel speed is adjustable with the controls in the combine cab. Refer to "Reel Speed" in your Combine Operator's Manual for adjustment details.

### 9.11.5.1 Optional Reel Drive Sprockets - D60 and FD70 Only

MACHINE HYDRAULICS	COMBINE	APPLICATION	DRIVE SPROCKET
All	All	Standard	19 Tooth
2000 - 2100 psi (13.79 - 14.48 MPa)	Case 2300, 2500 Series. AGCO Transverse Rotary	Combining Down Rice	10 Tooth
2500 psi (17.24 MPa)	CAT 500 Series. AGCO Axial Rotary	Combining Down Rice	12 Tooth
3000 psi (20.68 MPa)	NH CR, CX. Case IH 7010, 8010	Combining Down Rice	14 Tooth
Low Flow under 11 gpm	---	Combining Light Crops Above 10 mph (16 km/hr)	21 Tooth

Sprockets are available as an option to the factory installed sprocket. See your MacDon Dealer Parts Department to order sprockets.

Refer to Section 10.14.7 Reel Drive Sprocket - D60, FD70, for installation details.

## SECTION 9. OPERATION

### 9.11.6 GROUND SPEED

Ground speed should be such that the sickle can cut crop smoothly and cleanly, while giving the desired delivery of material to the opening. Excessive ground speed results in "ragged" cutting.

In tough-to-cut crops, reduce ground speed to reduce loads on cutting components and drives.

When cutting very light crops like short soybeans, ground speed may have to be reduced to allow reel to pull in small and short plants. Start at 3.0 - 3.5 mph (4.8 - 5.8 km/h) and adjust as required.

Higher ground speeds require heavier float settings to prevent excessive bouncing that would result in increased cutting component damage.

In most cases, as ground speed is increased, draper and reel speed should be increased to handle the extra material.

The chart below indicates the relationship between ground speed and area cut for the six header sizes.

**Example shown:** At a ground speed of 6 miles per hour (9.7 km/h) with a 25 foot header, the area cut in one hour would be approximately 18 acres (7.3 hectares).

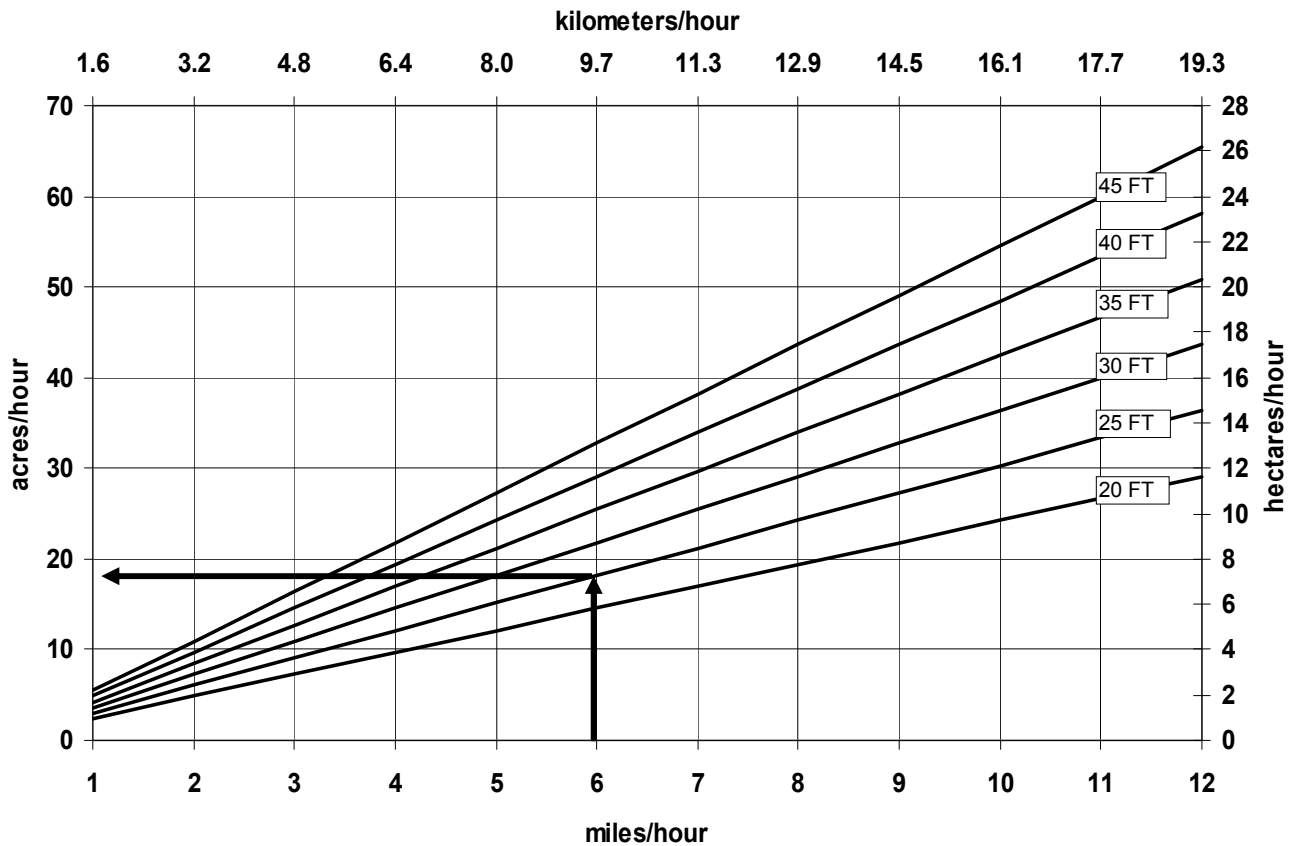



## SECTION 9. OPERATION

### 9.11.7 DRAPER SPEED

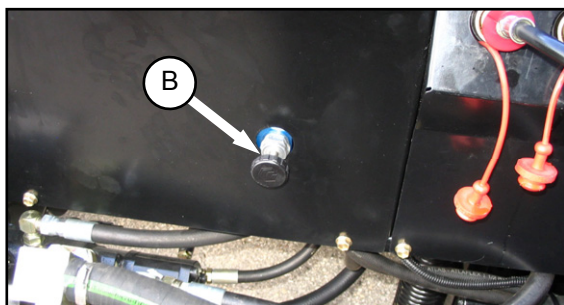
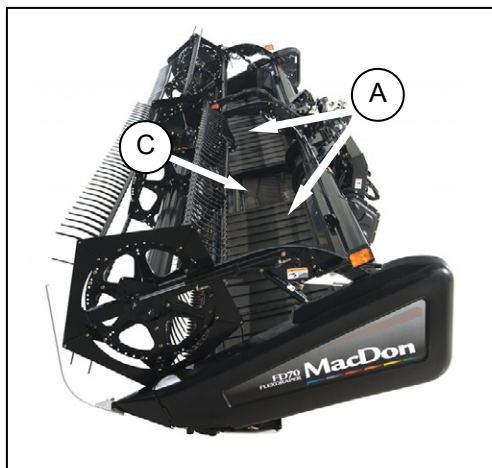

- a. The speed of the header/side drapers (A) is adjusted at the flow control (B) on the combine adapter.
- b. Turn knob (B) two turns from closed, and then adjust draper speed to achieve good feeding of crop onto adapter draper. Excessive draper speed will reduce draper life.

**NOTE**

*Three turns open produces full draper speed.*

**NOTE**

*If sufficient draper speed cannot be achieved, a possible cause is low relief pressure. Refer to the Technical Service Manual for checking and adjusting relief pressure.*

- c. The adapter feed draper (C) is driven by the adapter mounted hydraulic pump. The speed is factory set and cannot be adjusted.

## SECTION 9. OPERATION

### 9.11.8 KNIFE SPEED

The header knife drive is driven by the adapter mounted hydraulic pump. The knife drive speed is factory set for a feeder house speed of 575 rpm for CNH and John Deere adapters, and 780 rpm for AGCO and Lexion adapters.

#### IMPORTANT

For variable speed feeder houses, this will be the **minimum** speed setting. To operate variable speed feeder house at greater than minimum speed, flow to the knife drive motor must be reduced to prevent excessive speeds which could result in premature knife failure.

Check that the knife speed is in the range shown in the chart below using the procedure that follows. If adjustment is required, contact your MacDon Dealer or refer to the D60/FD70/CA20 Technical Manual.

Header Size	Recommended Knife Drive Speed Range (RPM)	
	SKD	DKD
25 FOOT	550 - 675	600 - 800
30 FOOT	550 - 650	600 - 725
35 FOOT	550 - 600	550 - 700
40 FOOT	525 - 600	550 - 650
45 FOOT	N/A	550 - 650



### WARNING

**Stop combine engine and remove key before making adjustments to machine. A child or even a pet could engage the drive.**

- Stop combine engine and remove key from ignition.



- Open the LH endshield.



### WARNING

**Ensure bystanders are clear before starting.**

- Start combine engine, engage the header drive, and run the combine at operating rpm.

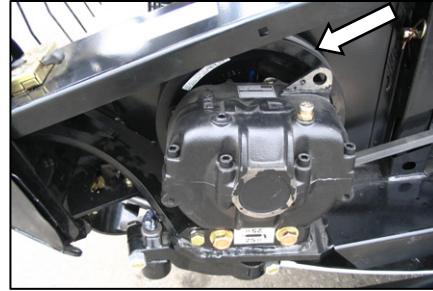

- Have someone check the rpm of the wobble box pulley using a hand held tachometer.
- Shutdown the combine.
- Compare actual pulley rpm with the values in the chart in the previous column.
- If adjustment to the wobble box pulley rpm is necessary, contact your MacDon Dealer or refer to the D60/FD70/CA20 Technical Manual.

### 9.11.9 REEL HEIGHT

Depending on crop height, adjust reel height to carry material through the sickle onto the drapers. Operate combine hydraulics as required. Refer also to Section 9.11.10 Reel Fore-Aft Position.

REEL HEIGHT CHART	
CROP CONDITION	REEL POSITION
Combining Down Rice	Down (Also Increase Reel Speed and/or Cam Setting)
Bushy or Heavy Standing	Up

Indications that reel may be too low are:

- crop loss over the header back tube;
- disturbance of crop on the drapers by the reel fingers; or
- crop being pushed down by the tine tubes.

#### IMPORTANT

Maintain adequate clearance to prevent fingers contacting the knife or the ground. Refer to Section 10.14.1 (D50, D60) or 10.14.2 (FD70) Reel Clearance to Cutterbar.

## SECTION 9. OPERATION

### 9.11.10 REEL FORE-AFT POSITION

Reel position has been found to be a critical factor in achieving good results in adverse conditions.

The reel position is factory set for average straight standing crop, and can be adjusted forward and backward for different crop conditions.

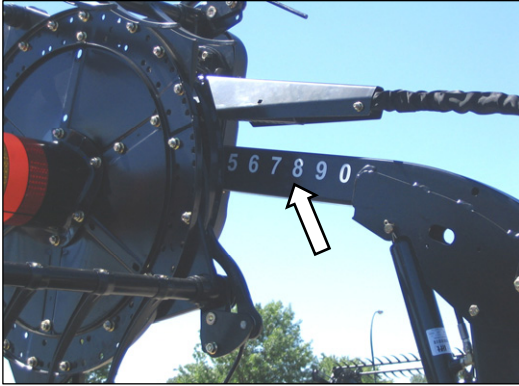

A gauge decal is provided on the reel right support arm for identifying a preferred position. The back edge of the reel cam disc is the gauge indicator.

- For straight standing crop, center the reel over the cutterbar (4 - 5 on gauge).
- For crops that are down, tangled, or leaning, it may be required to move reel ahead of cutterbar (to a lower number on the gauge).

#### IMPORTANT

When difficulty is encountered picking up flattened crop, adjust header angle to a steeper position. This tilts the entire reel/sickle/drafter combination and is often all that is required.

Refer to "Header Angle" in Combine Operator's Manual for adjustment details. Adjust reel position only if header angle adjustments are not satisfactory.

#### NOTE

*In difficult to pick up crops such as rice or severely lodged crops that require full forward positioning of the reel, the reel tine pitch can be set to provide proper placement of the crop onto the drapers.*

*Refer to Section 9.11.11 Reel Tine Pitch for adjustment details.*

#### IMPORTANT

Operating with the reel too far forward can cause the fingers to contact the ground before the Cutterbar. Lower the skid shoes or adjust header tilt as required when operating with the reel in this position, otherwise, damage to the fingers will occur.

### 9.11.10.1 Mechanical Adjustment - Fore-Aft



#### WARNING

**Stop combine engine and remove key before making adjustments to machine. A child or even a pet could engage the drive.**

- Lower or raise reel so support arms are horizontal.

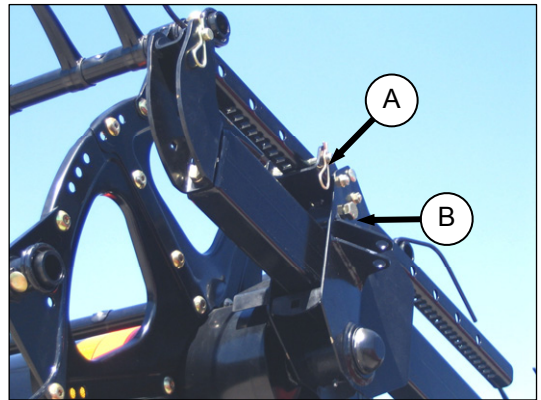

- Remove pin (A) at each support arm.
- Using a 15/16 in. wrench on bolt (B) turn sprocket inside reel arm to slide reel to the desired position. If reel binds on arms from misalignment, move in smaller increments (two holes at a time).
- Re-install pin (A). Be sure the same hole is used at each arm.
- Check that the reel is evenly adjusted.
- Check reel clearance to cutterbar after making changes to cam setting. Refer to Section 10.14.1 (D50, D60) or 10.14.2 (FD70) Reel Clearance to Cutterbar for measurements and adjustment procedures.

## SECTION 9. OPERATION

### 9.11.10.2 Hydraulic Adjustment - Fore-Aft

- Select the fore-aft adjust mode on the selector switch in the cab (if applicable).
- Operate the hydraulics to move the reel to the desired position, again using the gauge as a reference.
- Check reel clearance to cutterbar after making changes to cam setting. Refer to Section 10.14.1 (D50, D60) or 10.14.2 (FD70) Reel Clearance to Cutterbar for measurements and adjustment procedures.

### 9.11.10.3 Fore-Aft Cylinder Position

The reel can be moved approximately nine inches further aft by re-positioning the cylinders on the reel arms. This may be desirable when straight-combining canola.

- Position reel with support arms horizontal. Stop engine and move reel fully back. Remove key.



### WARNING

**Stop combine engine and remove key before making adjustments to machine. A child or even a pet could engage the drive.**

- Reposition center arm cylinder (Double Reel) as follows:

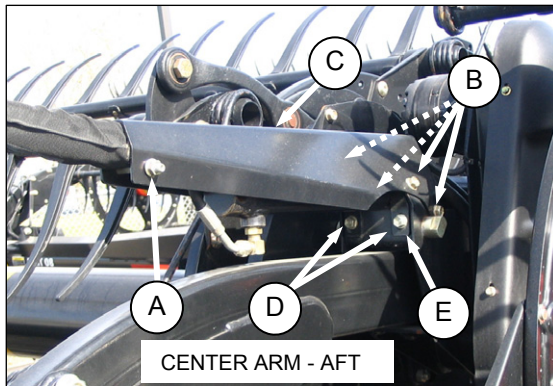

- Remove bolt and nut (A), and four bolts (B) securing hose shield (C) on center arm.
- Move hose shield and hoses away from cylinder.
- Remove bolts (D) that secure aft support plate (E) and remove the plate.

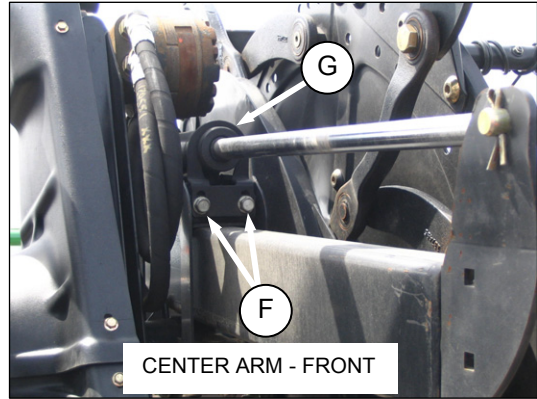

- Remove bolts (F) so that front support plate (G) is free to move up.

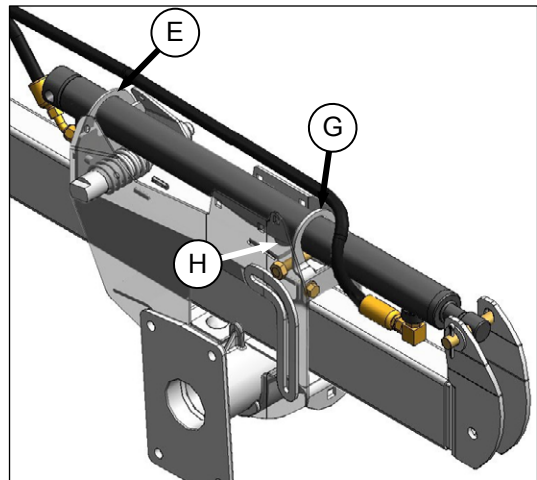

- Lift the aft end of the cylinder out of support assembly and re-position the cylinder so that cylinder center port fitting (H) engages the support assembly.

#### NOTE

*Loosen a hose fitting to allow repositioning of cylinder. Be sure to retighten fitting after cylinder installation.*

- Reinstall forward support plate (G) with bolts (F).
- Reposition hoses and reinstall shield (C) with bolts (B).
- Position hoses inside shield and install bolt and nut (A).
- Reinstall aft support plate (E) with bolts (D).

*(continued next page)*



## SECTION 9. OPERATION

- c. Reposition right arm cylinder (Double Reel) as follows:

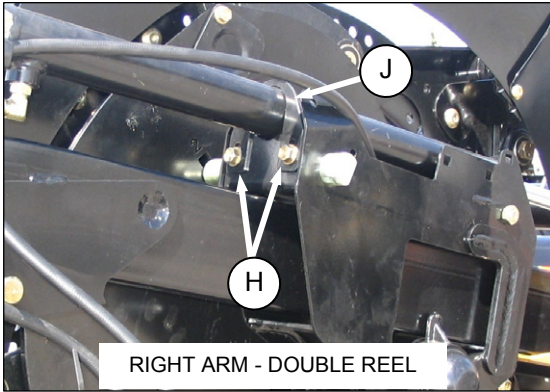

1. Remove bolts (H) that secure plate (J) and remove the plate.

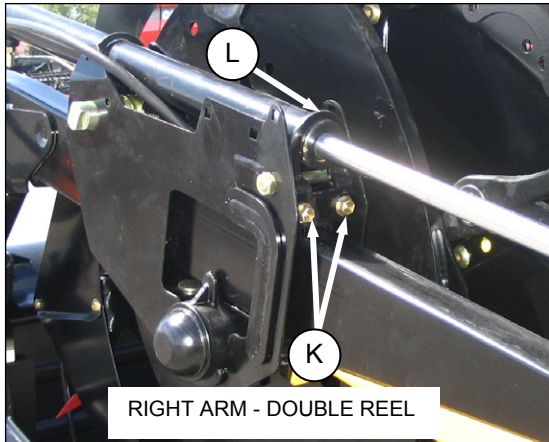

2. Remove bolts (K) so that front plate (L) is free to move up.

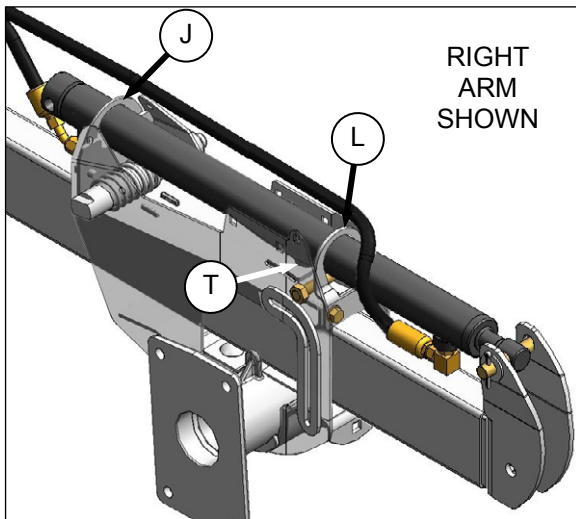

3. Lift the aft end of the cylinder out of support assembly and move the cylinder so that cylinder center port fitting (T) engages the support assembly.

### NOTE

*Loosen a hose fitting to allow movement of cylinder. Be sure to retighten fitting after cylinder installation.*

4. Reinstall plates (J) and (L) with bolts (H) and (K) respectively.
- d. Reposition right arm cylinder (Single Reel) as follows:

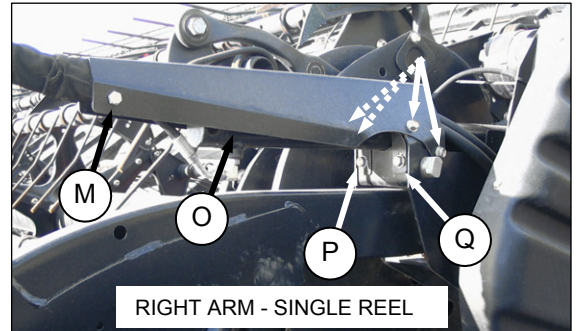

1. Remove bolt and nut (M), four bolts (N) securing hose shield (O).
2. Move hose shield and hoses away from cylinder.
3. Remove bolts (P) that secure aft plate (Q) and remove the plate.

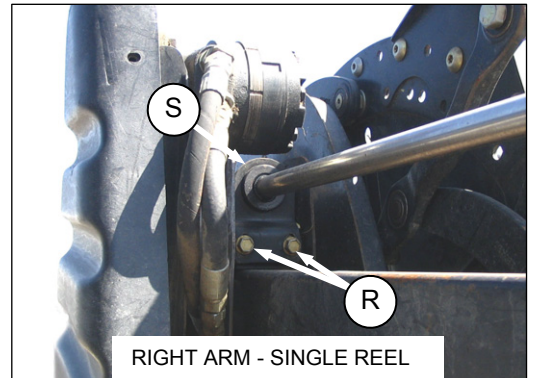

4. Remove bolts (R) so that front plate (S) is free to move up.

*(continued next page)*

## SECTION 9. OPERATION

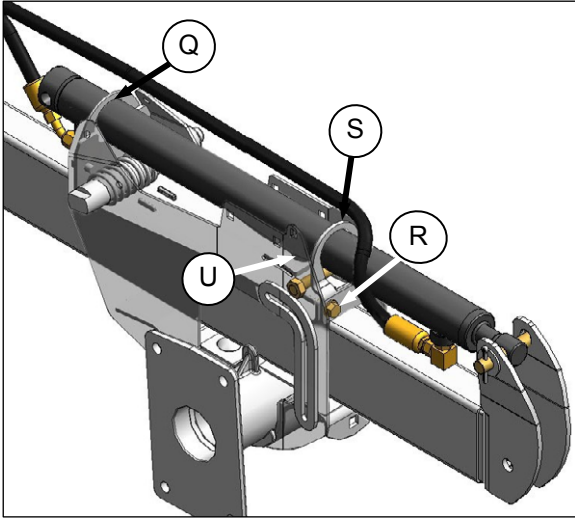

- Lift the aft end of the cylinder out of support assembly, and move the cylinder so that cylinder center port fitting (U) engages the support assembly.

### NOTE

*Loosen a hose fitting to allow movement of cylinder. Be sure to retighten fitting after cylinder installation.*

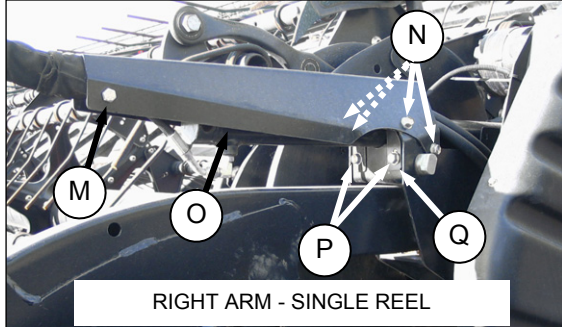

- Reinstall plates (S) and (Q) with bolts (R) and (P) respectively.
- Reposition hoses and reinstall shield (O) with bolts (N).
- Position hoses inside shield and install bolt (M) and nut.

- Reposition left arm cylinder (Double and Single Reel) as follows:

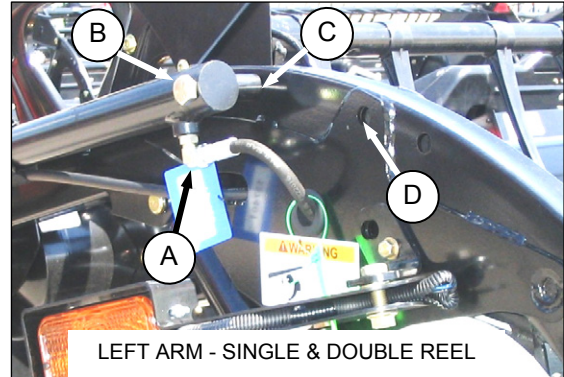

- Loosen fitting (A) to allow it to rotate when cylinder is repositioned.
  - Remove the bolt (B), nut, and spacer (C) that secures the cylinder to the reel arm.
  - Extend cylinder so that mounting hole lines up with new location (D) as shown.
  - Reinstall bolt (B) and nut with spacer (C).
  - Tighten fitting (A).
- Check reel clearance to back sheet, upper cross auger (if installed) and reel braces.
  - Adjust reel tine pitch if required. Refer to Section 9.11.11 Reel Tine Pitch, or Section 10.14.1 Reel Clearance to Cutterbar for adjustment procedures.

## SECTION 9. OPERATION

### 9.11.11 REEL TINE PITCH

#### IMPORTANT

The following describes the concept and operational guidelines of the pickup reel. Please read carefully before operating the machine.

#### 9.11.11.1 Concept

The pickup reel is designed to pick up flattened and severely lodged crops. It is not always necessary to increase the tine pitch (higher cam setting) to pick up crops that are lodged, but rather, the cam settings are mainly used to determine how the crop will get delivered to the drapers.

The position of the fingers relative to ground (tine pitch) is not significantly affected by the cam setting. For example, the cam position range is 33 degrees, but the corresponding finger pitch range is only 5 degrees at the lowest point of reel rotation.

For best performance, use the minimum cam setting that will deliver the crop past the rear edge of the cutterbar and onto the drapers.

#### 9.11.11.2 Operating Guidelines

The following outlines the function of each cam setting and includes guidelines for set-up in various crop conditions. The setting numbers are visible above the slots on the cam disc. Refer to Section 9.11.11.3 Cam Adjustment.

- **Cam Position 1** - Delivers the most even crop flow onto the drapers without fluffing up or disturbing the material. The crop is released quite close to the cutterbar and works best with the cutterbar on the ground. Some crops won't be delivered past the cutterbar when the cutterbar is raised off the ground and the reel is pushed forward. Initially, have the reel speed about equal to the ground speed.

- **Cam Position 2** - Recommended starting position for most crops and conditions. This setting gives a finger tip speed approximately 20% faster than the reel speed. If crops tend to stall on the cutterbar with the reel in a forward position, the cam setting should be increased to push the crop past the rear edge of the cutterbar. If the crop is getting fluffed or the flow across the drapers is disrupted, the cam setting should be decreased.

- **Cam Positions 3 and 4** - Mainly used to leave long stubble. Allows the reel to reach forward and lift the crop across the knife and onto the drapers. The further forward the reel, the higher the cam setting should be. Cam 4 would be used with the reel being fully forward to leave the maximum amount of stubble in lodged crops. This setting gives a finger tip speed approximately 30% faster than the reel speed.

**Cam Position 4, Header Angle At Maximum, and Reel Fully Forward** - Provides the maximum amount of reel reach below the cutterbar to pick up lodged crops and gives a finger tip speed approximately 35% faster than the reel speed.

Cutting height is set to approximately 8 inches (203 mm) to leave a significant amount of stubble. In damp materials such as rice, it is possible to double ground speed because the amount of material that is being cut is less.

#### NOTE

*High cam settings with the reel fore-aft position at 4 - 5, severely decrease the draper capacity because the reel disrupts crop flow across the drapers. The fingers are still engaged in the crop that is moving on the drapers. High cam settings are recommended only with the reel at or close to full forward settings.*

#### IMPORTANT

The reel to cutterbar clearance should always be checked following adjustments to reel tine pitch and reel fore-aft position.

Refer to Section 10.14.1 (D50, D60) and 10.14.2 (FD70) Reel Clearance to Cutterbar.

For detailed reel set-up information, refer to Section 9.11 HEADER SET-UP.



## SECTION 9. OPERATION

### 9.11.11.2.1 Cam Adjustment



#### WARNING

Stop combine engine and remove key before making adjustments to machine. A child or even a pet could engage the drive.

#### D60, FD70

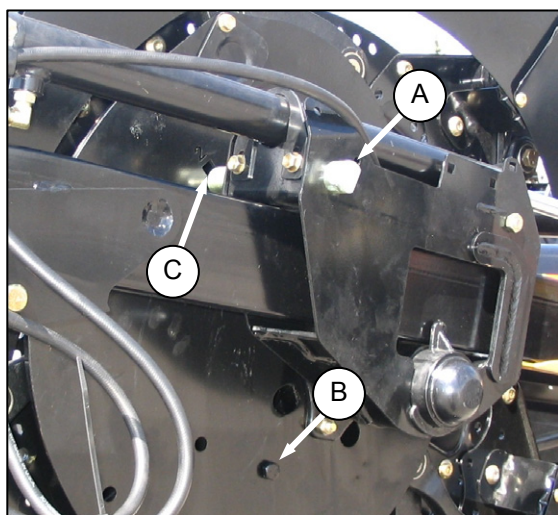

D60 AND FD70

- Using a  $\frac{3}{4}$  in. wrench, turn the cam latch pin (A) counter clockwise to release the cam disc.

#### IMPORTANT

Secure cam position before operating machine.

- Use the wrench on bolt (B) to rotate cam disc and align the latch pin (A) with the desired hole (1 to 4) at (C) in the cam disc.
- Turn the latch pin (A) clockwise to engage and lock the cam disc.
- On a double reel, repeat above procedure for the other.

#### D50

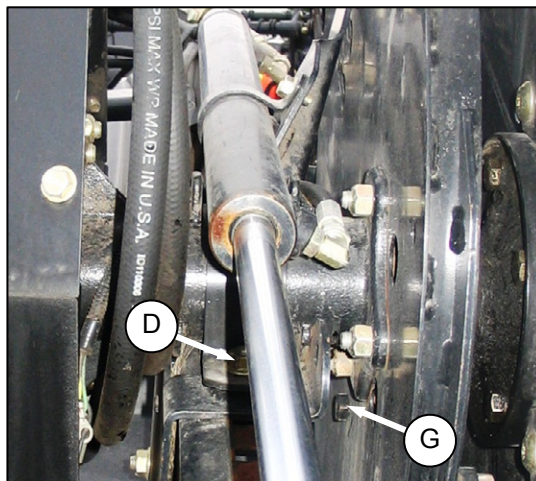

D50

- Loosen bolt (D) on clamp securing cam disc to reel arm.

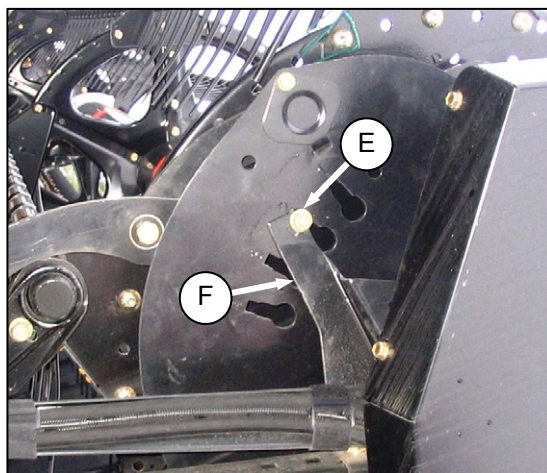

D50

- Loosen bolt (E) in cam slot and rotate cam clockwise so that bolt disengages cam stop (F).
- Remove bolt (E) from cam disc.
- Rotate cam disc to desired position (use wrench on bolt head (G) if necessary).
- Insert bolt head into numbered slot and rotate cam disc so that bolt engages cam stop.
- Tighten cam stop bolt (E), and clamping bolt (D).
- Check reel clearance to cutterbar after making changes to cam setting. Refer to Section 10.14.1 (D50, D60) or 10.14.2 (FD70) Reel Clearance to Cutterbar for measurements and adjustment procedures.



## SECTION 9. OPERATION

### 9.11.12 CROP DIVIDERS AND RODS

#### 9.11.12.1 Divider Rods

The divider rods are removable. The removable divider rods are suitable when crop is down, while the crop divider without the rods is better in standing crops. See the chart below for recommended rod use for various crops.

WITH DIVIDER RODS	WITHOUT DIVIDER RODS
Lodged Cereal Peas Lentils Canola Winter Forage Sudan Grass Flax Alfalfa Grass Seed Soybeans	Standing Cereal Edible Beans Soybeans Rice Milo

Remove divider rods as follows:

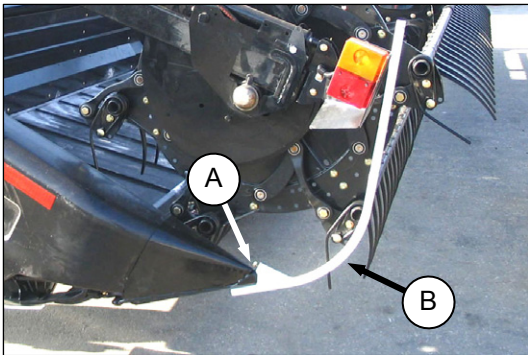

- a. Loosen bolt (A) and remove rod (B).



- b. Store both rods on the inboard side of the right endsheet.

#### 9.11.12.2 Crop Dividers

The crop dividers are removable to suit installation of a vertical knives, and to decrease the transport width.



### DANGER

**To avoid bodily injury or death from unexpected start-up or fall of raised machine, stop engine, remove key and engage lift cylinder stops before going under machine to remove crop dividers or for any reason.**

#### 9.11.12.2.1 Removal

##### D60, FD70

- a. Raise header and engage header lift cylinder lockouts. Refer to combine operating manual. Stop engine and remove key.
- b. Open header endshields. Refer to Section 10.4 ENDSHIELDS AND COVERS.

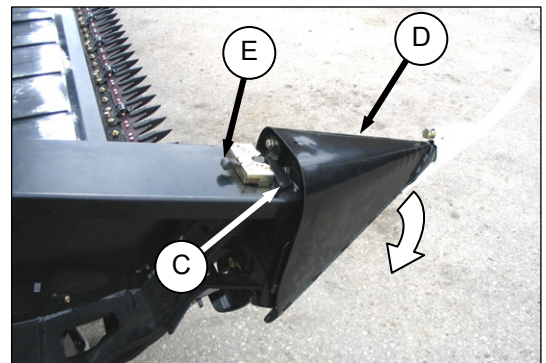

- c. Lift safety lever (C).
- d. Hold onto divider (D), push lever (E) to open latch and lower divider.
- e. Lift divider off endsheet, and store as follows:

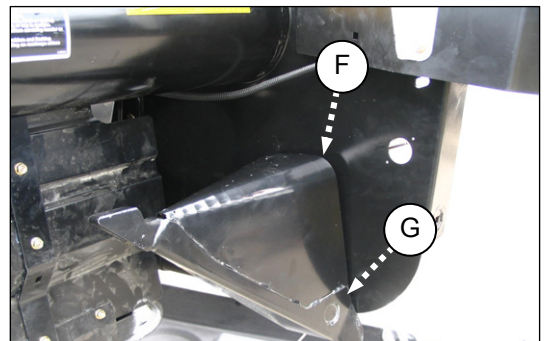

1. Locate pin (F) on divider in hole in endsheet at location shown.
  2. Lift divider and locate lugs (G) on divider into bracket on endsheet. Ensure lugs engage bracket.
- f. Close header endshield.

*(continued next page)*

## SECTION 9. OPERATION

### **D50**

- Raise header and engage lift cylinder lockouts. Refer to combine operating manual.
- Open header endshield. Refer to Section 10.4 ENDSHIELDS AND COVERS.

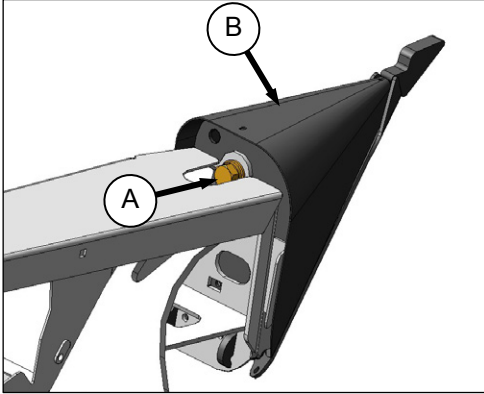

- Remove bolt (A), lock-washer, flat washer, and lower divider (B).
- Lift divider off endsheet.
- Close header endshield.

### **9.11.12.2.2 Installation**

#### **D60, FD70**

- Open header endshield.

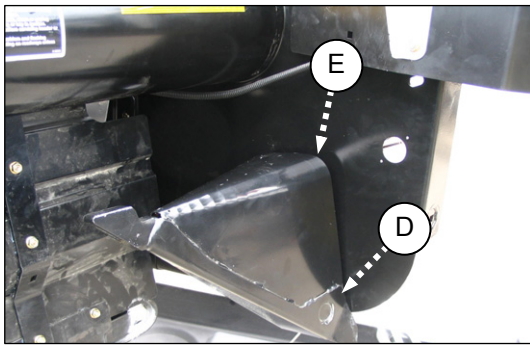

- At divider storage location, lift divider to disengage lugs (D) at lower end and then lower it slightly to disengage pin (E) from endsheet.

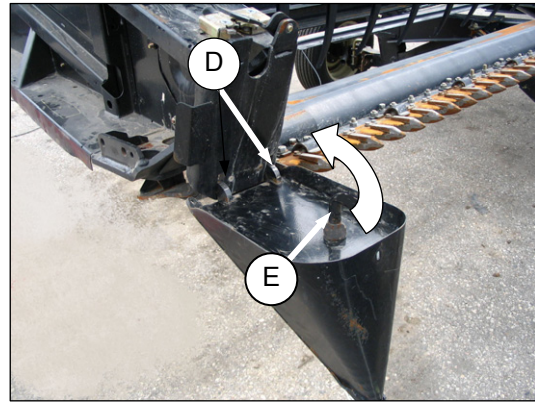

- Position crop divider as shown by locating lugs (D) in holes in endsheet.

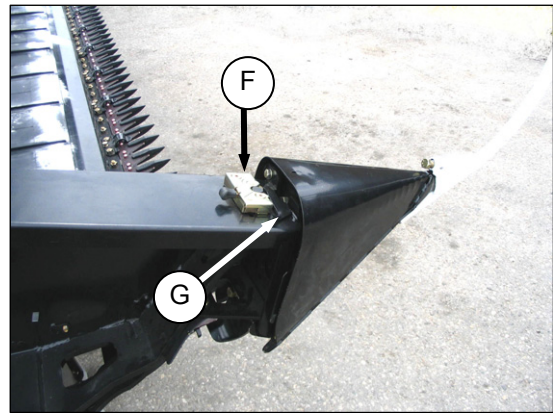

- Lift forward end of divider until pin (E) at top of divider engages and closes latch (F).
- Push safety lever (G) down to lock pin in latch.

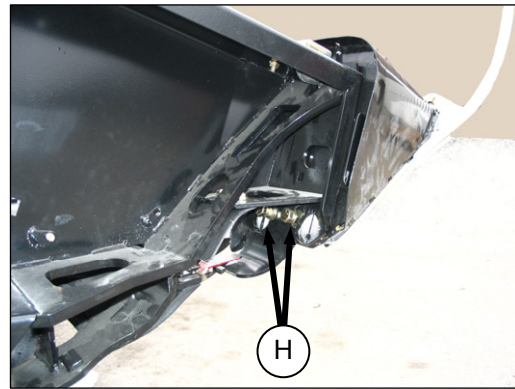

- Check that divider does not move laterally. Adjust bolts (H) as required to tighten divider and remove lateral play when pulling at divider tip.
- Close endshield.

*(continued next page)*

## SECTION 9. OPERATION

### D50

- a. Open endshield.
- b. Remove from storage.

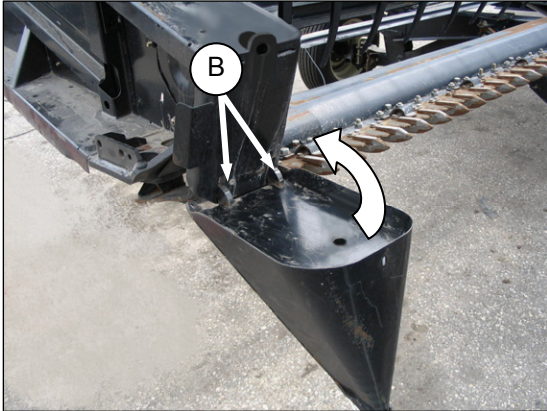

- c. Position crop divider as shown by locating lugs (B) in holes in endsheet.

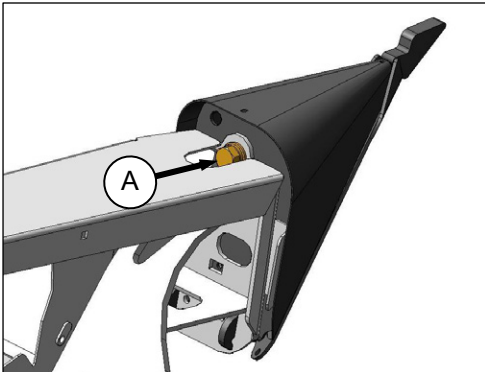

- d. Lift forward end of divider and install bolt (A), lock-washer, and flat washer. Tighten bolt.



- e. Check that divider does not move laterally. Adjust bolts (C) as required to tighten divider and remove lateral play when pulling at divider tip.
- f. Close endshield.

### 9.11.12.3 Rice Dividers

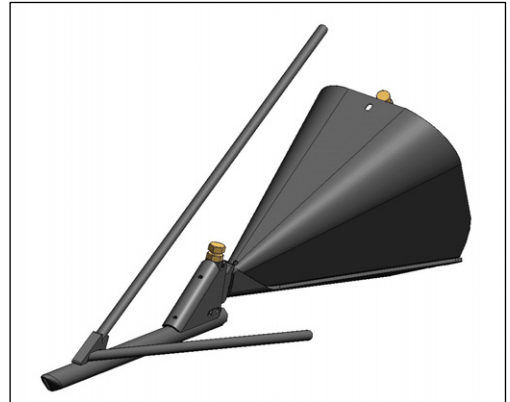

Special rice dividers can be installed and used when required and are available as an option. See Section 12.15 RICE DIVIDER KIT.

The installation and removal procedures are the same as for the standard crop dividers.



## SECTION 9. OPERATION

### 9.12 DRAPER DEFLECTORS

D60 single knife headers are equipped with rubber deflectors that are attached to the inboard side of the endsheets to prevent material from falling through the gap between the endsheet and the draper.

In some cases, material hesitates on the deflectors and will not flow onto the draper. Replace the existing deflector with a narrower one, or rework the existing deflector.

#### 9.12.1 Deflector Replacement

- Raise reel fully and lower header.
- Shutdown combine. Remove key. Engage reel props.

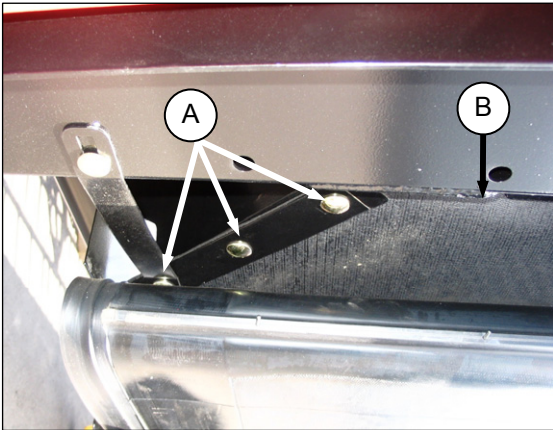

- Remove the three carriage bolts (A) securing the aft end of the existing deflector (B) to the frame behind the backsheet.

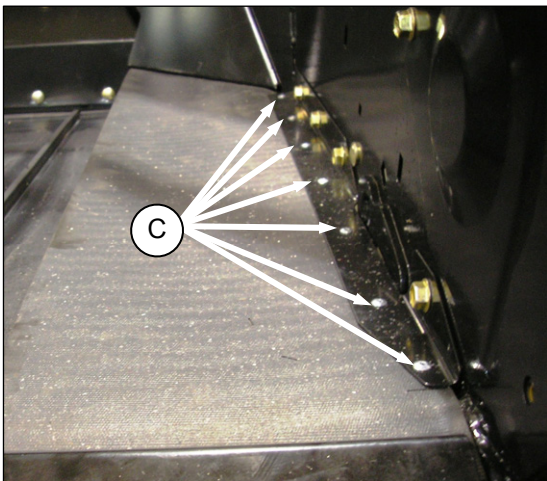

- Drill out the seven pop-rivets (C) along the endsheet and remove the deflector.

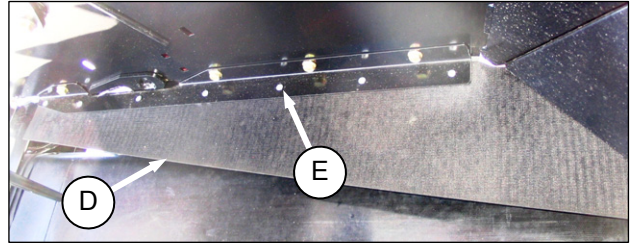

- Position new deflector (part number 172381) (D) onto endsheet bracket and attach with seven pop-rivets (part number 18768) (E).
- Re-install the three carriage bolts (A) at aft end of deflector.

#### 9.12.2 DEFLECTOR REWORK

Trim existing deflectors as follows:

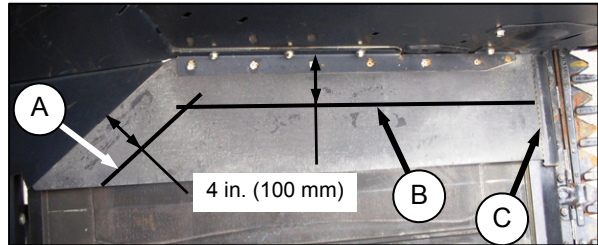

- Mark a straight line (A) on the deflector 4 in. (100 mm) from and parallel to the back edge of the deflector.
- Mark another line (B) on the deflector 4 in. (100 mm) from and parallel to the endsheet.
- Using a sharp knife, cut rubber deflector along the lines (A) and (B), taking care not to cut the draper underneath the deflector.
- Cut the rubber deflector along the steel retainer (C) from the inboard edge up to line (B) and remove the excess rubber.



DEFLECTOR AFTER TRIMMING

- Use the cut-off portion of deflector as a template to rework the deflector on the opposite end.



## SECTION 9. OPERATION

### 9.13 KNIFE HEAD SHIELD

The shield attaches to the endsheet and reduces the knife head opening to prevent cut crop from accumulating over the knife head, which could damage the wobble box and the endsheet.

It is recommended that the shield(s) be installed when harvesting severely lodged crop or any crop condition where the heads tend to accumulate over the knife head.

The shield(s) and mounting hardware are available from your MacDon Dealer and are installed as follows:

#### NOTE

*Shields are slightly different depending on header size. Ensure proper shield is used. See Section 12.18 KNIFE HEAD SHIELD.*

- a. Raise reel fully, lower header to ground, shutdown combine, and remove key.



#### CAUTION

**Always engage reel props before working under reel.**

- b. Engage reel arm locks.



#### DANGER

**To avoid bodily injury or death from unexpected start-up or fall of raised machine, stop engine, remove key and engage lift cylinder stops before going under machine.**

#### NOTE

*The knife head shield is supplied in flattened form and can be bent to suit installation on pointed or stub guard cutterbars, and on double knife headers.*



#### CAUTION

**Wear heavy gloves when working around or handling sickles.**

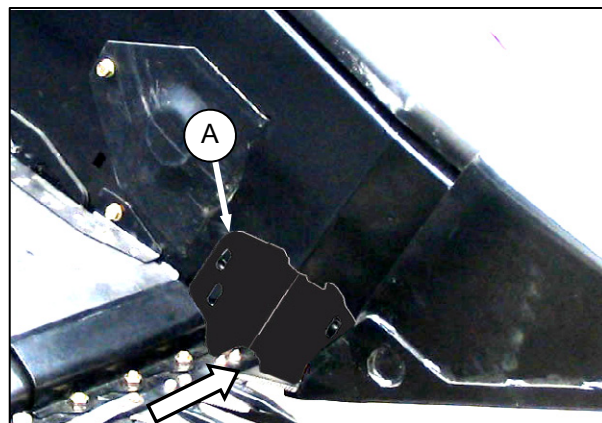

- c. Locate knife head shield (A) against endsheet as shown.
- d. Orient the shield so that cutout matches profile of knife head.
- e. Bend shield along slit to conform to endsheet.

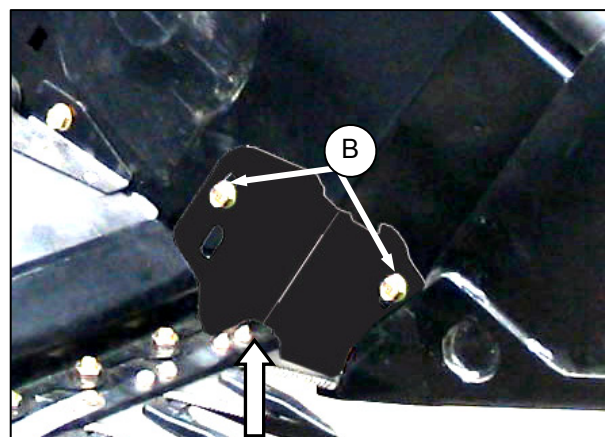

- f. Place shield on endsheet, align mounting holes, and install two 3/8 in. x 1/2 Torx head bolts (B).
- g. Snug up the bolts just enough so that shield can be adjusted as close as possible to knife head.
- h. Manually rotate wobble box pulley to move knife and check for areas of contact between the knife head and shield.
- i. If required, adjust shield to avoid interference with the knife.
- j. Tighten bolts.

## SECTION 9. OPERATION

### 9.14 HEADER LEVELLING

The adapter is factory set to provide the proper level for the header and should not normally require adjustment. If the header is not level, perform the following checks prior to adjusting the leveling linkages.

#### IMPORTANT

The adapter float springs are not used to level the header.

- Check combine tire pressures.
- Check that the combine feeder house is level. Refer to your Combine Operator's Manual.
- Check that top of adapter is level with combine axle.

Make fine adjustments to header leveling as follows:

- a. Park combine on level ground.
- b. Check float lock is disengaged (header can float).
- c. Check and set float adjustment. Refer to Section 9.11.3 Header Float.
- d. Set header approximately 6 inches (150 mm) off ground and check that float linkage is against down stops. Note high and low end of header.

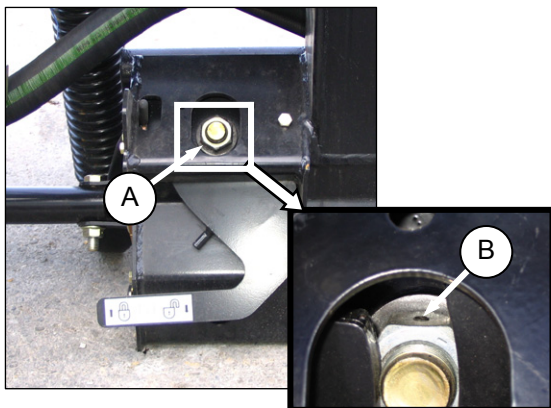

- e. Adjust level with nut (A) at each float lock as follows. Use small adjustments (1/4 -1/2 turn) and adjust each side equally but in opposite directions:

#### NOTE

Set screw (B) does not require loosening for adjustments up to 1/2 turn of nut (A).

1. Turn low-side nut **clockwise** to raise header.
2. Turn high-side nut **counter clockwise** to lower header.

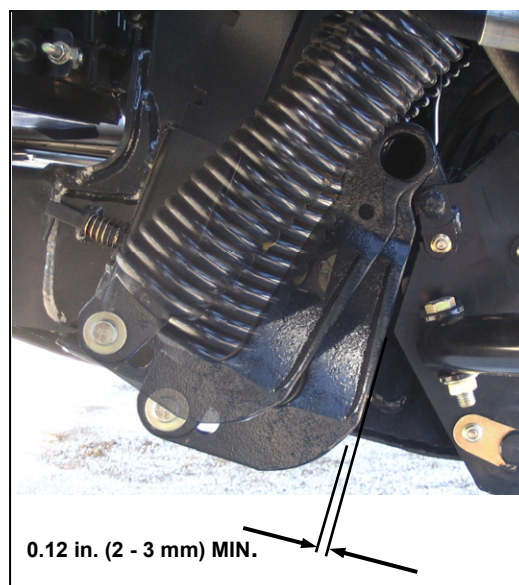

#### NOTE

Adjustment of more than two turns in either direction may adversely affect header float.

Always be sure there is a minimum 0.12 inch (2 to 3 mm) clearance between frame and back of bellcrank lever as shown.

#### NOTE

Float does not require adjustment after levelling header.

## SECTION 9. OPERATION

### 9.15 UNPLUGGING CUTTERBAR

- a. Stop forward movement of the machine and disengage header drives.
- b. With header on ground, back up several feet and engage header drive clutch.



#### CAUTION

**Lowering rotating reel on a plugged cutterbar will damage the reel components.**

- c. If plug does not clear, disengage header drive clutch and raise header fully.



#### WARNING

**Stop engine and remove key before removing plugged material from header. A child or even a pet could engage the drive.**

- d. Shut off engine, remove key and engage park brake.
- e. Engage header lift cylinder locks.



#### WARNING

**Wear heavy gloves when working around sickle.**

- f. Clean off cutterbar by hand.

#### NOTE

*If sickle plugging persists, see Section 11 TROUBLESHOOTING.*

### 9.16 UNPLUGGING ADAPTER

- a. Stop forward movement of the machine and disengage header drives.
- b. Raise header slightly off the ground and raise the reel.
- c. Activate the header reverse drive control on the combine and engage the header drive.
- d. When plug clears, disengage header drive and de-activate the reverse switch.
- e. Re-engage header drive.



## SECTION 9. OPERATION

### 9.17 UPPER CROSS AUGER



The cross auger helps deliver very bulky crops across the header onto the windrow or into the combine.

Removable beater bars assist in delivering material through the header opening, but if wrapping occurs, the beater bars can be removed as follows:



#### WARNING

**Stop engine and remove key before removing plugged material from header. A child or even a pet could engage the drive.**

- a. Lower header to ground, shutdown combine, and remove key.

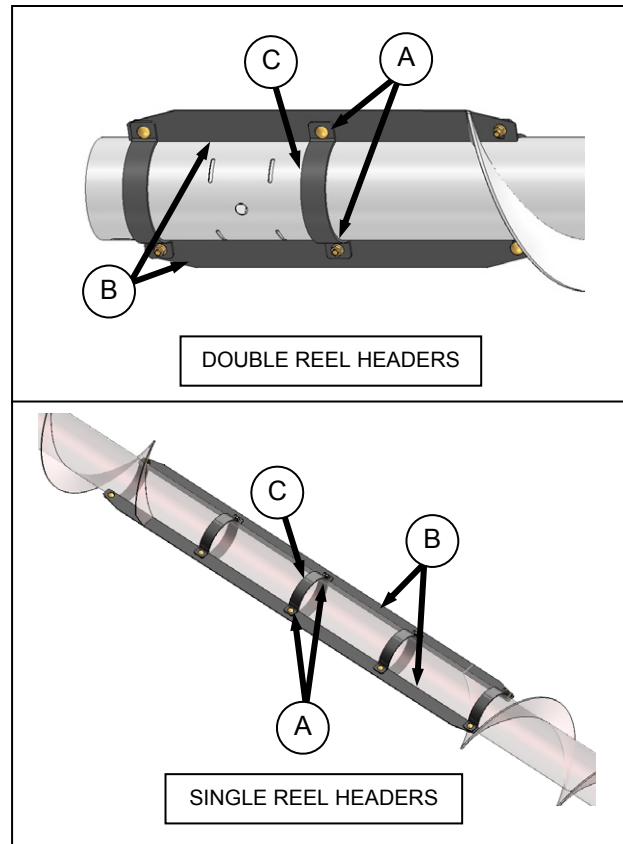

- b. Remove bolts (A) securing bars (B) and clamps (C) to auger tubes and remove bars and clamps.

#### To re-install the beater bars:

- a. Locate one beater bar (B) with one clamp set (C) on auger tube and loosely secure with carriage bolt (A) and nut. Bolt head must face direction of auger rotation.
- b. Locate remaining clamp sets on tube and loosely attach to beater bar with carriage bolts and nuts. Bolt heads must face direction of auger rotation.
- c. Position second beater bar in clamps and secure with carriage bolts and nuts.
- d. Tighten bolts.

## SECTION 9. OPERATION

### 9.18 TRANSPORTING HEADER



#### WARNING

Do not drive combine with header attached on a road or highway at night, or in conditions which reduce visibility, such as fog or rain. The width of the header may not be apparent under these conditions.

#### 9.18.1 ON THE COMBINE



#### CAUTION

- Check local laws for width regulations and lighting or marking requirements before transporting on roads.
- Follow all recommended procedures in your Combine Operator's Manual for transporting, towing etc.
- Disengage header drive clutch when travelling to and from the field.
- Before driving combine on a roadway, be sure flashing amber lamps, red tail lamps and head lamps are clean and working properly. Pivot amber lamps for best visibility by approaching traffic. Always use these lamps on roads to provide adequate warning to other vehicles.
- Do not use field lamps on roads, they may confuse other drivers.
- Before driving on a roadway, clean slow moving vehicle emblem and reflectors. Adjust rear view mirror and clean windows.
- Lower the reel fully and raise header unless transporting in hills. Maintain adequate visibility and be alert for roadside obstructions, oncoming traffic and bridges.
- When travelling downhill, reduce speed and keep header at a minimum height. This provides maximum stability if forward motion is stopped for any reason. Raise header completely at bottom of grade to avoid contacting ground.
- Travel speed should be such that complete control and machine stability are maintained at all times.

#### 9.18.2 TOWING

The headers can be towed behind the combine or with the Slow Speed Transport/Stabilizer Wheel option, or on an approved header transporter. Refer to the Combine Operator's Manuals, or see your MacDon Dealer.

##### 9.18.2.1 Attaching Header To Towing Vehicle



#### CAUTION

- To avoid bodily injury and/or machine damage caused by loss of control:
- Weight of towing vehicle must exceed header weight to ensure adequate braking performance and control.
- Do not tow with any highway capable vehicle. Use only an agricultural tractor, agricultural combine, or properly configured MacDon windrower.
- Ensure that reel is down and fully back on support arms to increase header stability in transport. For headers with hydraulic reel fore-aft, never connect the fore-aft couplers to each other. This would complete the circuit and allow the reel to creep forward in transport, resulting in instability.
- Check that all pins are properly secured in transport position at wheel supports, hitch and cutterbar support.
- Check tire condition and pressure prior to transporting.
- Connect hitch to towing vehicle with a proper hitch pin with a spring locking pin or other suitable fastener.
- Attach safety hitch chain to towing vehicle. Adjust safety chain length to remove all slack except what is needed for turns.
- Connect header wiring harness 7-pole plug to mating receptacle on towing vehicle. (The 7-pole receptacle is available from your MacDon Dealer parts department).
- Ensure lights are functioning properly, and clean the slow moving vehicle emblem and other reflectors. Use flashing warning lights unless prohibited by law.

## SECTION 9. OPERATION

### 9.18.2.2 Towing The Header



#### CAUTION

THIS IS INTENDED AS SLOW SPEED TRANSPORT.



#### CAUTION

- To avoid bodily injury and or machine damage caused by loss of control:
- Do not exceed 25 mph (40 km/h). Reduce transport speed to less than 5 mph (8 km/h) for corners and slippery or rough conditions.
- Do not accelerate when making or coming out of a turn.
- Obey all highway traffic regulations in your area when transporting on public roads. Use flashing amber lights unless prohibited by law.

### 9.18.3 CONVERTING FROM TRANSPORT TO FIELD POSITION

- a. Block the tires to prevent header rolling and unhook from towing vehicle.

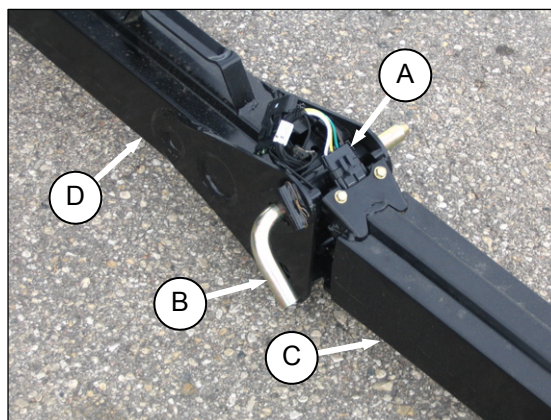

- b. Remove tow-bar as follows:
  1. Disconnect wiring connector (A) on tow-bar.
  2. Remove pin (B) from tow-bar and disassemble forward section (C) from aft section (D).

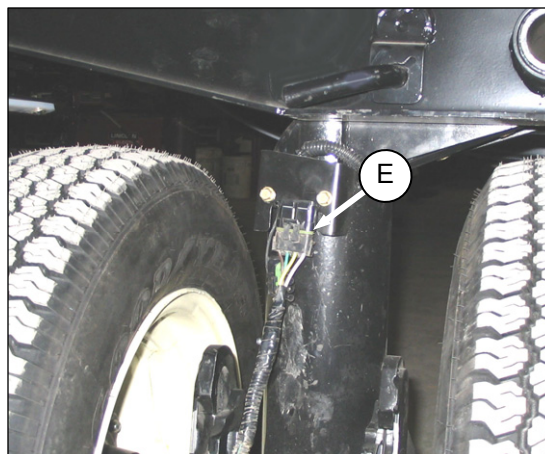

3. Disconnect wiring connector (E) at front wheel.

*(continued next page)*



## SECTION 9. OPERATION

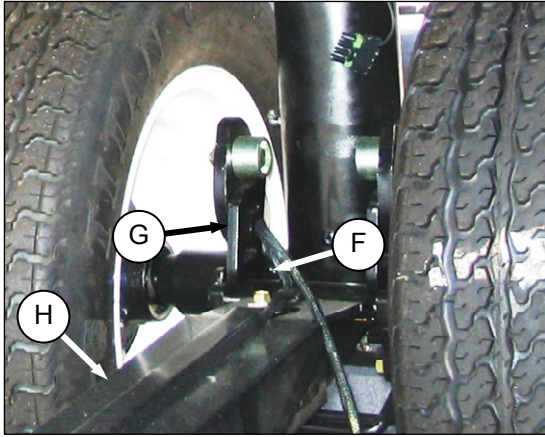

4. Remove clevis pin (F) and set aside for later installation.
  5. Push latch (G) and lift tow-bar (H) from hook. Release latch.
- c. Store tow-bar on header as follows:
1. Locate larger end of one section of tow-bar in cradle (K) on header back-tube.

2. For clevis end of tow-bar, secure in support (L) on endsheet with hitch pin (M). Secure with lynch pin.
  3. Install rubber strap (N) on cradle.
  4. Similarly locate other section of tow-bar in cradle at other end of header.
  5. Secure tube end in support (O) with clevis pin (P). Secure with hairpin.
  6. Install rubber strap (N) on cradle.
- d. Attach header to combine. Refer to Section 7. HEADER ATTACHMENT/DETACHMENT.

### IMPORTANT

Carrying the tow-bar on the header will affect the main header float on all headers and the wing balance on the FD70 FlexDraper. Refer to Section 10.15 HEADER WING FLOAT, and Section 9.11.3 Header Float for adjustment procedures.

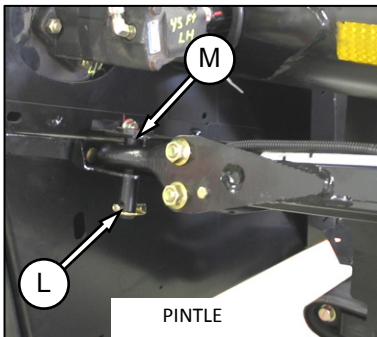
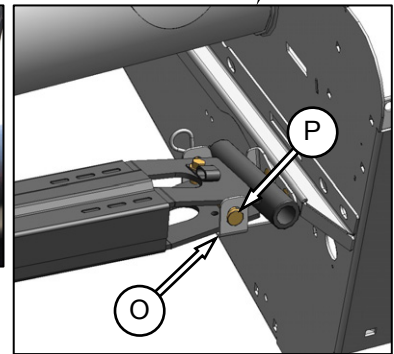
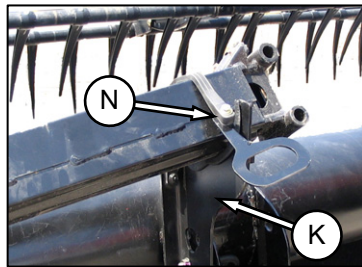
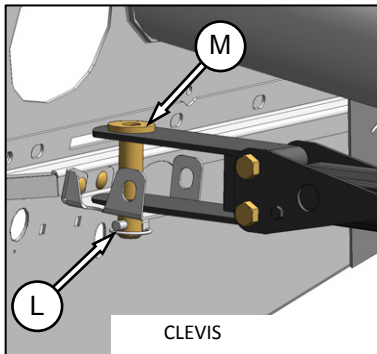
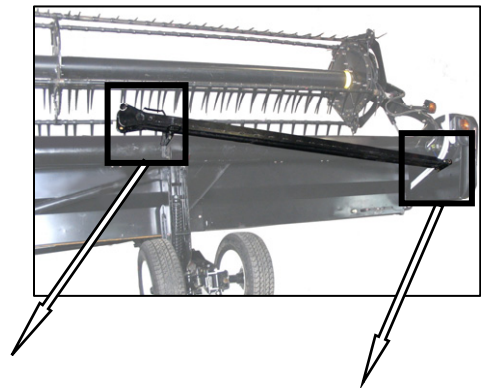
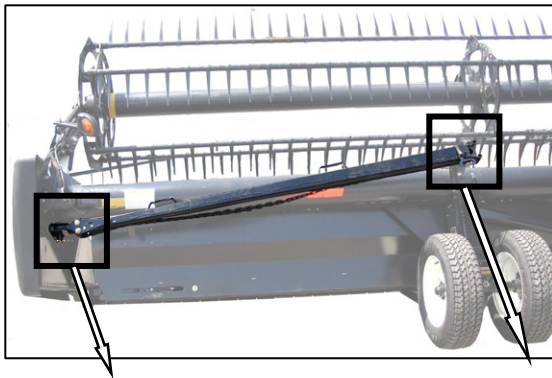

## SECTION 9. OPERATION

### 9.18.3.1 Front Wheels To Field



#### DANGER

To avoid bodily injury or death from unexpected start-up or fall of raised header, stop engine, remove key and engage header lift cylinder stops before going under header for any reason.

- a. Raise header fully.
- b. Swivel the wheel assembly so that wheels are aligned with lower frame.

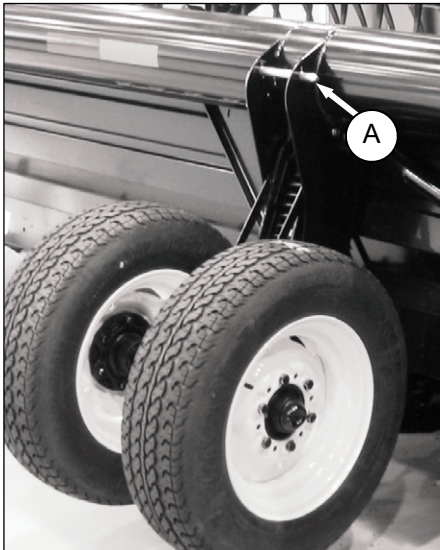
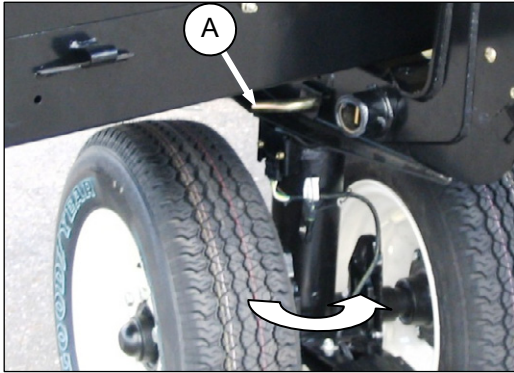

- c. Remove pin (A) and pull wheel assembly towards rear of header. Store pin (A) in hole at top of leg.

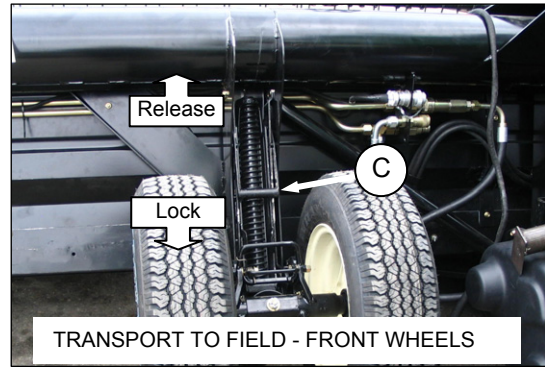

- d. Pull handle (C) to release and lower the linkage.

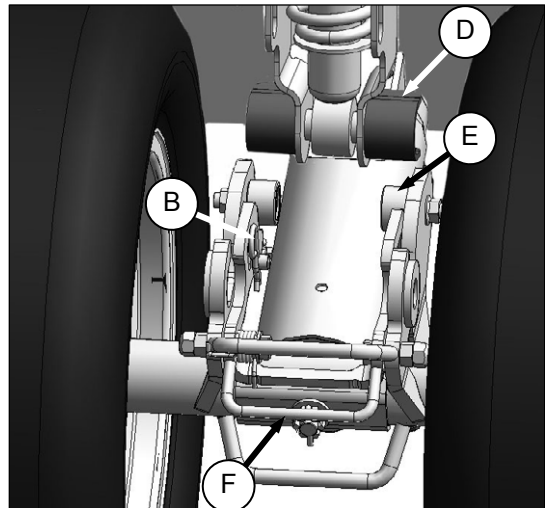

TRANSPORT TO FIELD - FRONT WHEELS

- e. Align lift hook (D) with lug (E) and lift wheel assembly to engage pin in hook. Ensure latch (F) is engaged.
- f. Install clevis pin (B) and secure with hairpin.

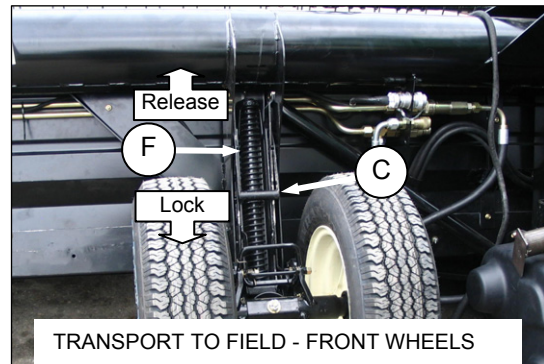

TRANSPORT TO FIELD - FRONT WHEELS

- g. Lift wheel assembly to desired height and slide linkage (F) into appropriate slot in vertical support.
- h. Push down on handle (C) to lock.



## SECTION 9. OPERATION

### 9.18.3.2 Rear Wheels To Field

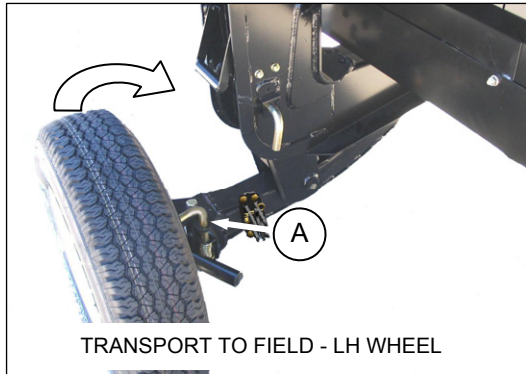

- a. Pull pin (A) at left wheel, swivel wheel clockwise and lock with pin (A).

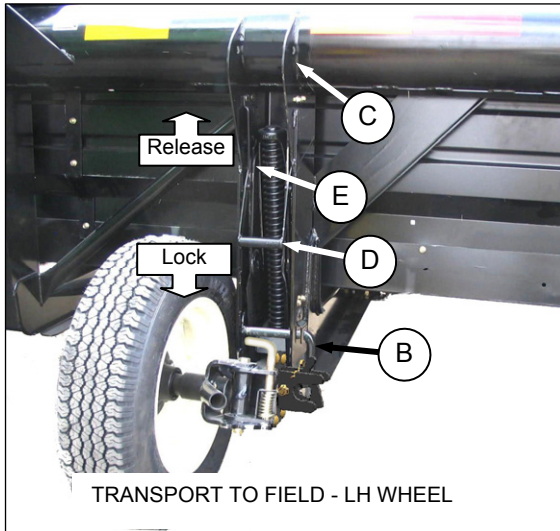

- b. Remove pin at (B). Store pin at (C) as shown.  
 c. Pull handle (D) to release.  
 d. Lift wheel to desired height and engage support channel into slot (E) in upper support.  
 e. Push down on handle (D) to lock.

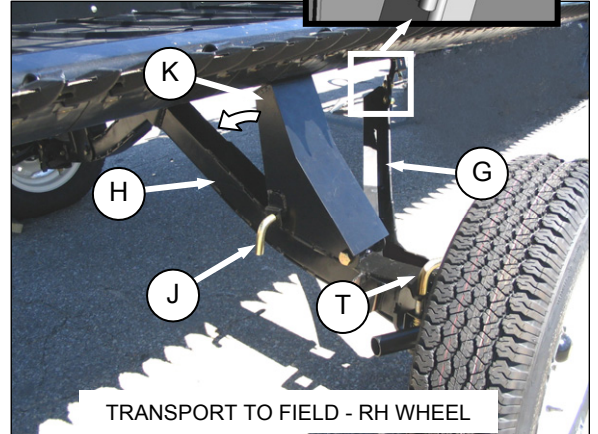
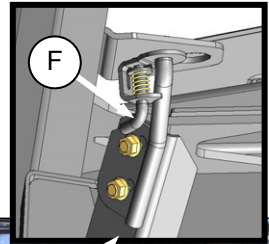

- f. At right cutterbar wheel, pull pin (F) on brace (G), disengage brace from cutterbar, and lower the brace against axle (H).  
 g. Remove pin (J), lower the support (K) onto axle, and reinsert pin into support.  
 h. Swing axle clockwise to rear of header.

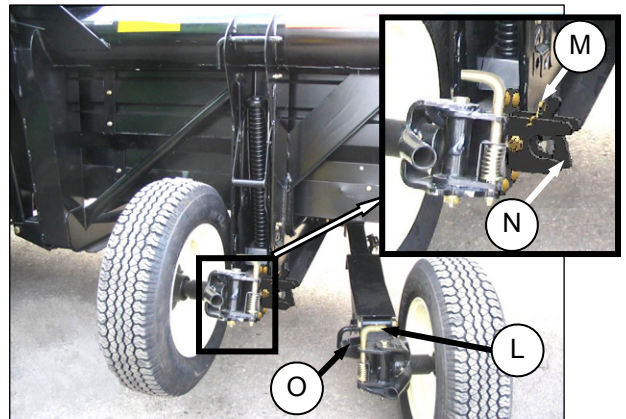

- i. Pull pin (L) at right wheel, swivel wheel counter clockwise to position shown and lock with pin.  
 j. Remove hairpin (M) from latch (N).  
 k. Lift wheel, lift latch (N) and engage lug (O) onto left axle. Ensure latch closes.  
 l. Secure latch with hairpin (M).

*(continued next page)*

## SECTION 9. OPERATION

### IMPORTANT

Check that wheels are locked and that handle is in locked position.



FIELD POSITION - LH SIDE



FIELD POSITION - RH SIDE

- m. The conversion is complete when the wheels are as shown.



## SECTION 9. OPERATION

### 9.18.4 CONVERTING FROM FIELD TO TRANSPORT POSITION

Raise header fully and proceed as follows:



#### DANGER

To avoid bodily injury or death from unexpected start-up or fall of raised header, stop engine, remove key and engage header lift cylinder stops before going under header for any reason.

#### 9.18.4.1 Left Wheels To Transport



#### CAUTION

Stand clear of wheels and release linkage carefully as wheels will drop once the mechanism is released.

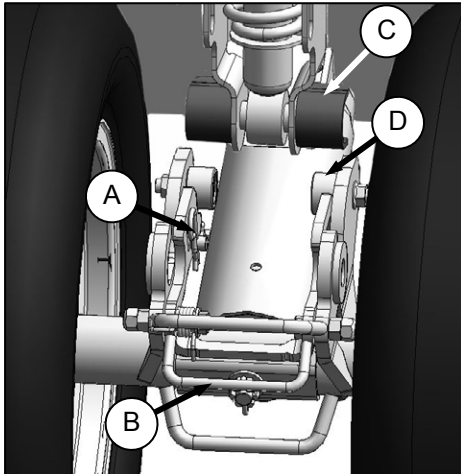

FIELD TO TRANSPORT - LH SIDE

- Remove clevis pin (A).
- Pull latch handle (B), and disengage link (C) from lug (D) to lower wheels.

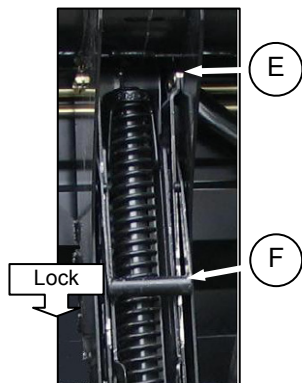

FIELD TO TRANSPORT - LH SIDE

- Place suspension assembly in full upward location (E) in leg and lower handle (F) to lock.

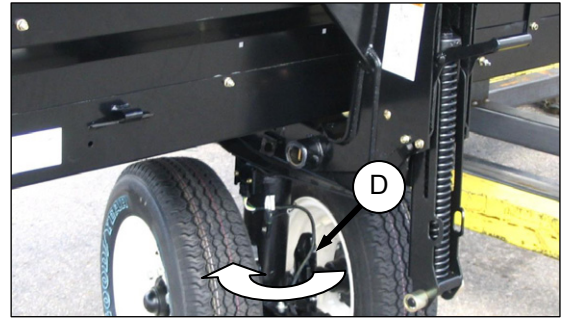

FIELD TO TRANSPORT - LH SIDE

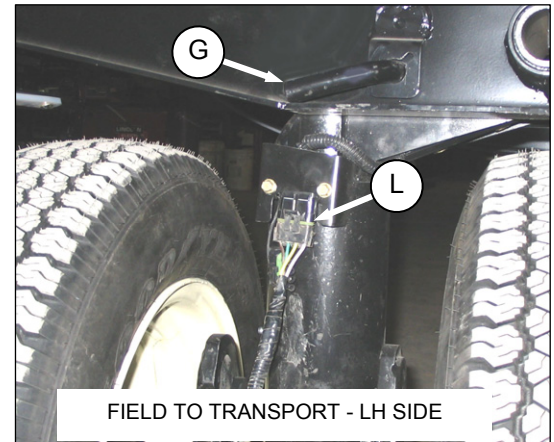

FIELD TO TRANSPORT - LH SIDE

- Remove pin (G) from storage at top of leg, move and swivel wheels clockwise so that lug (D) faces forward.
- Insert pin (G) and turn pin to lock.

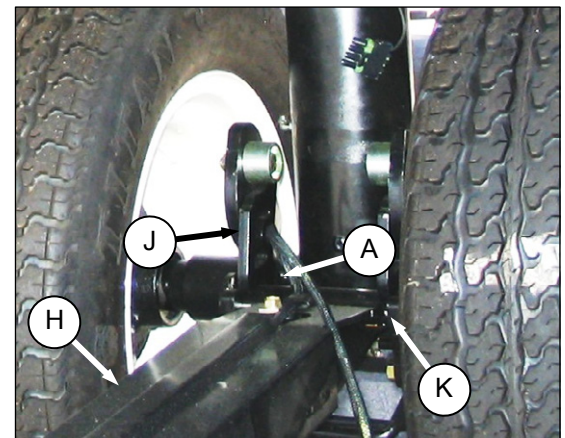

FIELD TO TRANSPORT - LH SIDE

- Locate tow-bar (H) onto axle and push against latch (J) until tow-bar pins drop into hooks (K).
- Check that latch (J) has engaged tow-bar.
- Install clevis pin (A) and secure with hairpin.
- Connect plug (L) for lights.

## SECTION 9. OPERATION

### 9.18.4.2 Right Side Wheels To Transport

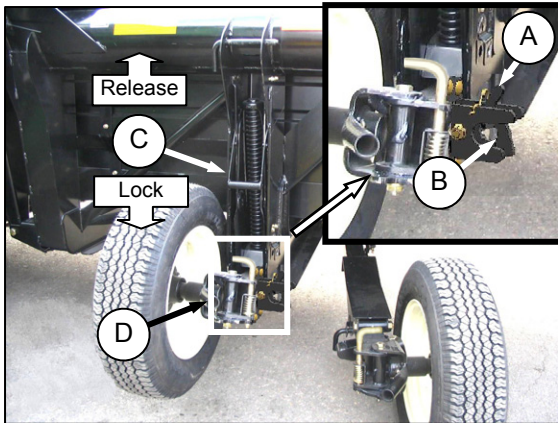

FIELD TO TRANSPORT - RH SIDE

- At wheels at the right end of header, remove hairpin (A) from latch.
- Lift latch (B), disengage right axle and lower to ground.



### CAUTION

Stand clear of wheels and release linkage carefully as wheels will drop once the mechanism is released.

- Carefully pull handle (C) to release the spring and let the wheel drop to the ground.
- Lift wheel and linkage with handle (D) and position linkage in second slot from bottom.
- Lower handle (C) to lock.

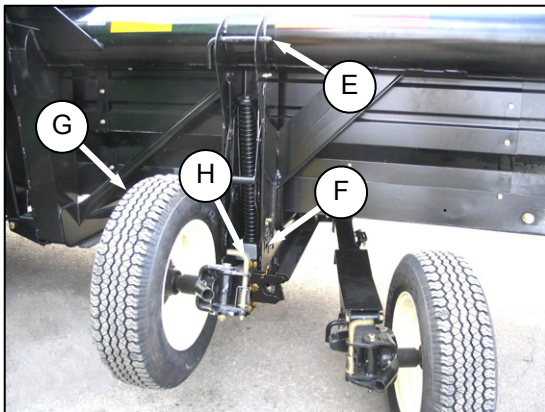

FIELD TO TRANSPORT - RH SIDE

- Remove pin (E) and install at (F) to secure linkage. Turn pin (E) to lock.
- To position the left wheel (G), pull pin (H), swivel wheel counter clockwise, and re-lock with pin (H).



FIELD TO TRANSPORT - LH WHEEL

- Left wheel is now in transport position as shown in illustration.



FIELD TO TRANSPORT - RH SIDE

- Pull pin (J), swivel wheel clockwise as shown, and lock with pin (J).

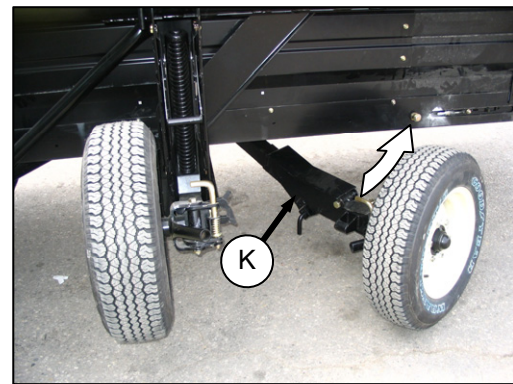

FIELD TO TRANSPORT - RH WHEEL

- Swivel the right axle (K) to front of header.

*(continued next page)*

## SECTION 9. OPERATION

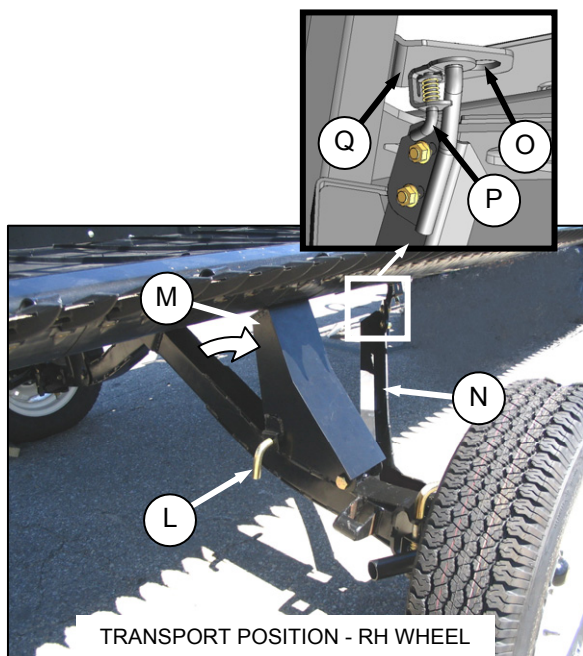

- k. Remove pin (L), raise support (M) to position shown and reinsert pin (L).

### **IMPORTANT**

Ensure pin (L) engages the tube on the axle.

- l. Swing brace (N) into position as shown and insert brace into slot (O) behind cutterbar. Position brace so that pin (P) engages hole in bracket (Q).
- m. Right hand wheel is now in transport position.



## SECTION 9. OPERATION

### 9.19 WINDROWING

The D60 Harvest Header can be used for windrowing with a combine, but the CA20 Combine Adapter requires modifying by removing the auger and the feed deck as per the following procedure. The auger and feed deck can be re-attached for combining by reversing the following procedure.

#### 9.19.1 ADAPTER MODIFICATION

- Remove header from adapter. Refer to Section 8.1.1 Disassembly.
- Place blocks under the adapter legs on level ground. The blocks should be the same length as the legs to keep the adapter stable.
- Remove adapter from combine. Refer to Section 7 HEADER ATTACHMENT/DETACHMENT.

##### 9.19.1.1 Feed Deck Removal

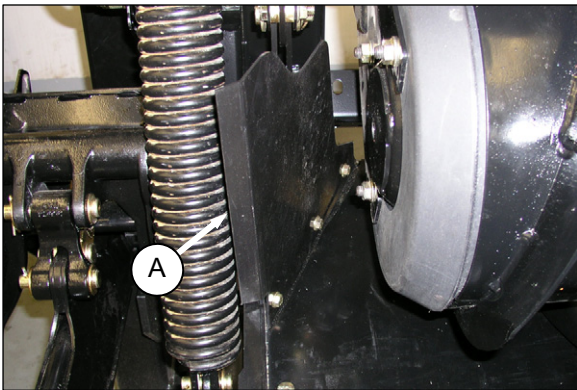

- Remove the poly deflector (A) on the right side of the feed auger.

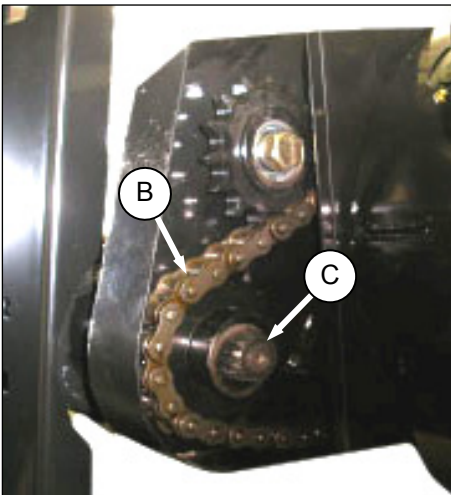

- Remove the auger drive chain (B). Refer to Section 10.9.3 Auger Drive chain Replacement.
- Remove the drive sprocket (C).

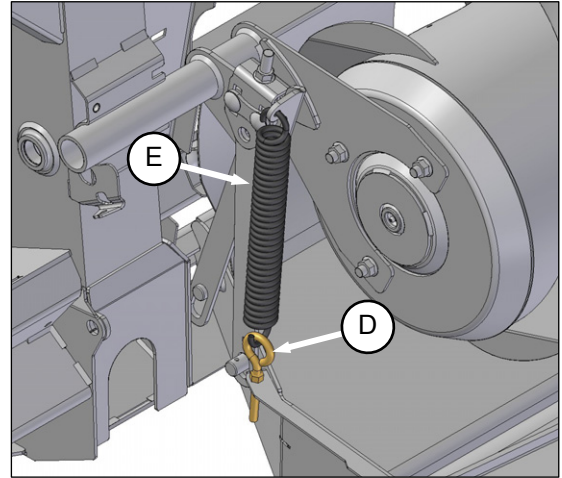

- Loosen eyebolt (D) on auger spring (E) until spring can be removed. Repeat for other spring.

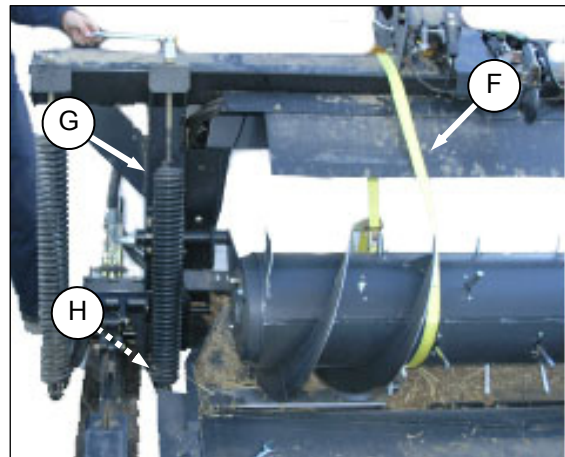

- Support auger at both ends with adjustable straps (F) as shown.
- Loosen inboard float springs (G) until tension is released.
- Remove the pin (H) at the lower end of the spring and remove the adjuster bolt to remove the spring. Set aside for re-installation.

*(continued next page)*

## SECTION 9. OPERATION

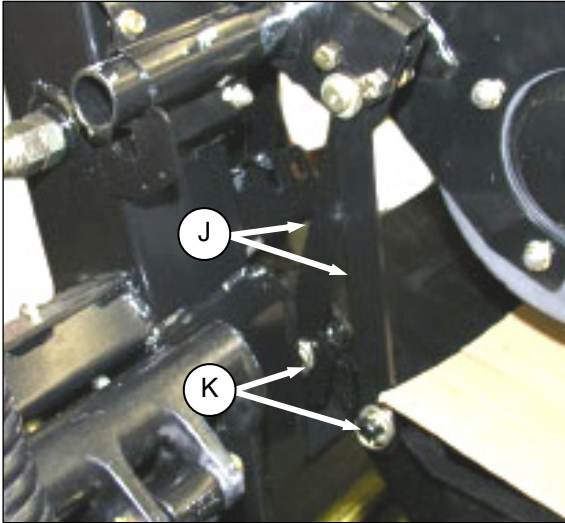

- h. Tighten straps until float limiter bars (J) are loose. Remove pins (K) at lower end of bars.

### NOTE

*Float limiter bars are stamped with letter F.*

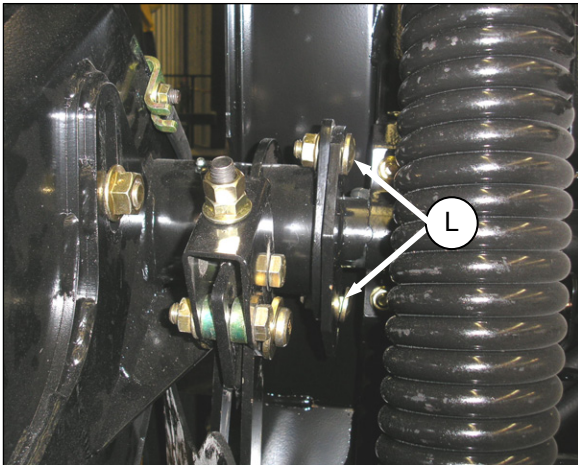

- i. Loosen the two bolts (L) attaching feed auger to drive shaft.

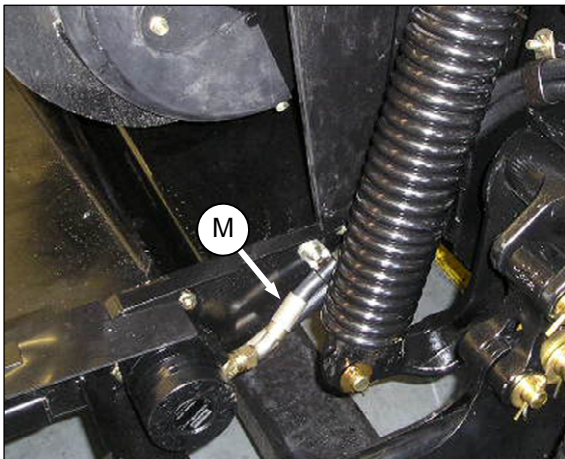

- j. Disconnect hoses (M) at feed draper motor and re-connect ends with a 5/8 inch JIC male to male fitting.

### NOTE

*Mark hoses so that they are re-installed in the matching ports when re-installing the feed deck. Install plugs on motor ports.*

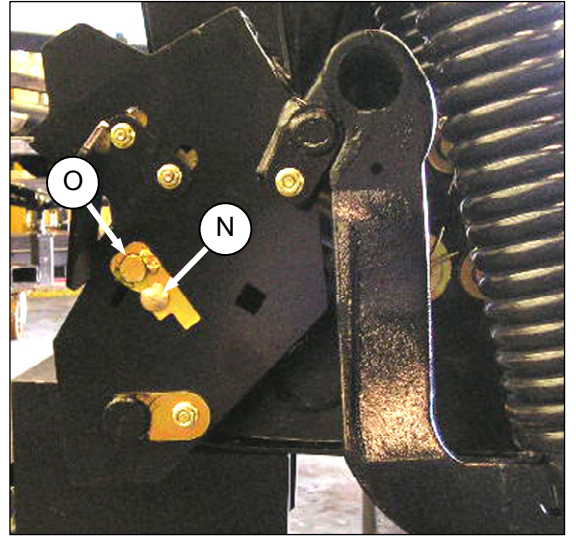

- k. Loosen the two bolts (N) that secure the deck retaining pins (O), one per side.

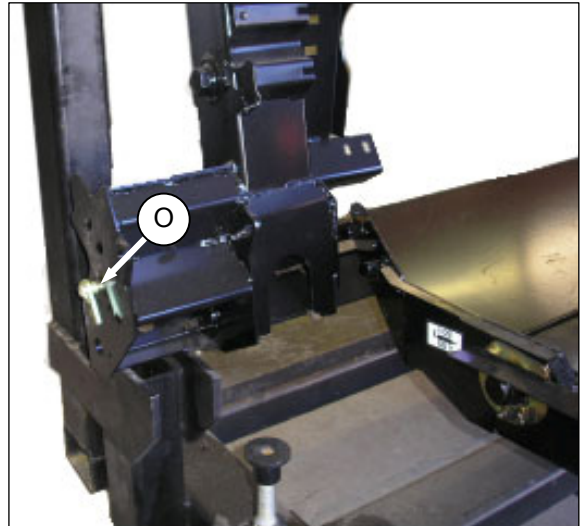

- l. Remove pins (O) and pull feed deck away. Replace pins for re-installation.



## SECTION 9. OPERATION

### 9.19.1.2 Auger and Transition Pan Removal

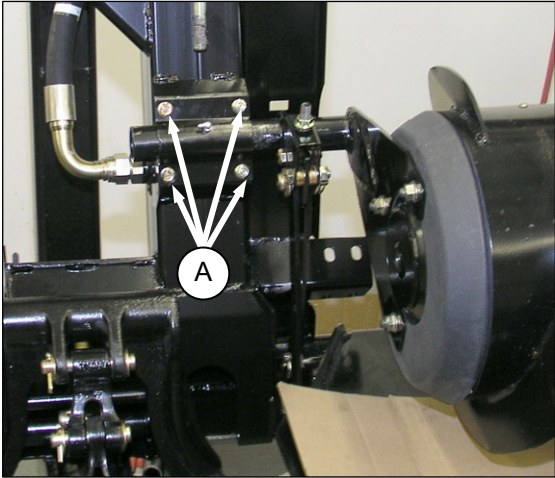

- Remove the four bolts (A) that attach the auger right hand support to adapter frame.
- Move the auger to the right to allow the auger left hand support to slide off the auger drive shaft tube.
- Remove auger and set aside for re-installation.

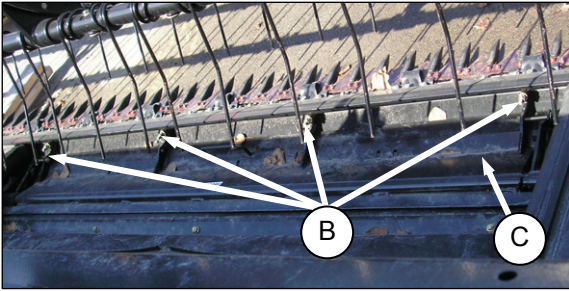

- Remove the four bolts (B) securing the transition pan (C) to the cutterbar.
- Pull transition pan away from cutterbar so that it slides off header legs. Set aside for re-installation.
- Re-install the inboard float springs (D).

Tighten adjuster bolt until tension is approximately that of the adjacent spring.

Tension will be adjusted after the header deck is shifted and header is re-attached to the combine.

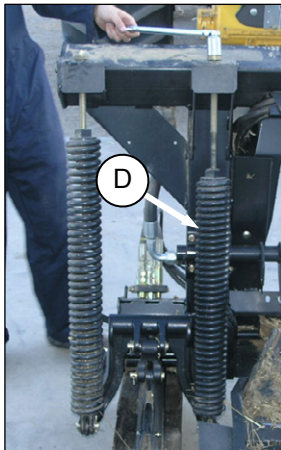

### 9.19.1.3 Reposition Deck

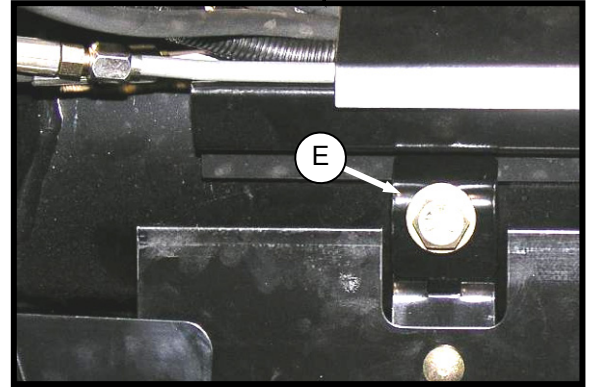
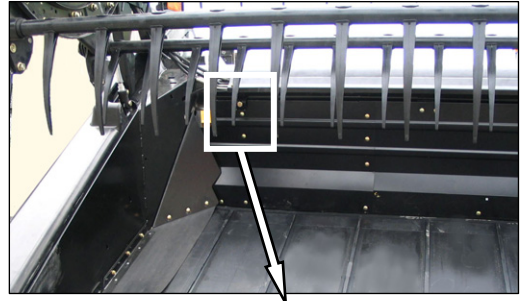

- Loosen bolt (E) on the deck that is to be moved.
- Slide deck to close off the center opening. Retighten bolt (E).

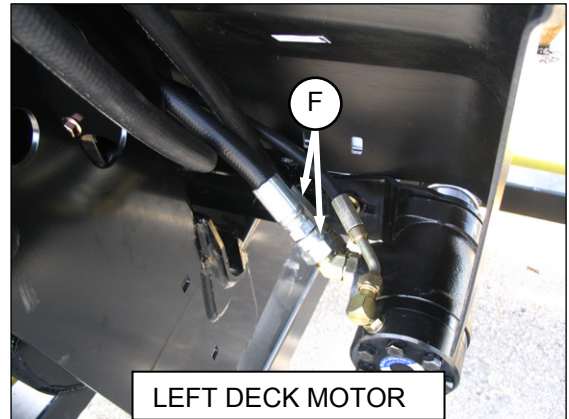

- Reverse the draper drive motor hoses (F) on the moved deck so that the draper turns the same direction as the existing deck.

*(continued next page)*



## SECTION 9. OPERATION

### NOTE

If right deck is moved, loosen clamp on plastic sleeve at right deck drive motor so that hoses can be reversed.

Re-tighten clamp.

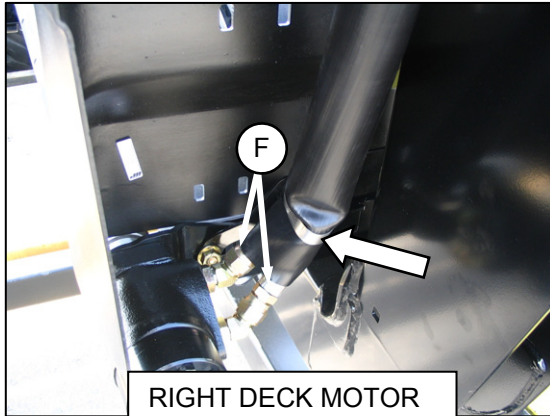

### IMPORTANT

The deck on the 45 foot header needs to be supported at the front when repositioning it, and requires the installation of an additional deck support.

- d. Install support as follows:

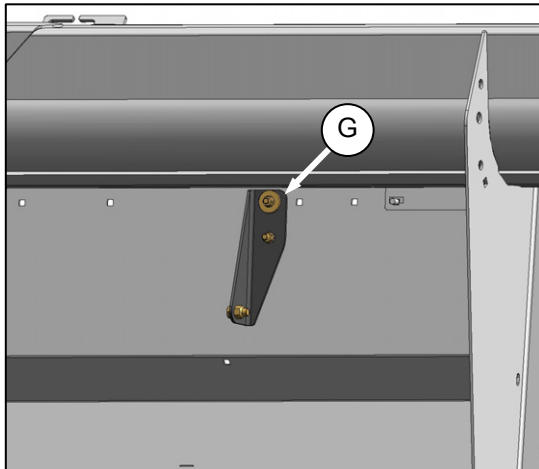

1. Remove support (G) from backsheet and remove hardware from support. Retain hardware.

2. Install support on lift cylinder bracket at center of backtube with bolt and nut. Do not tighten.

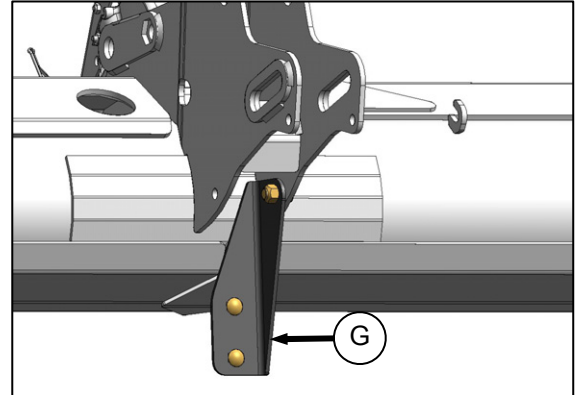

3. After deck is moved, attach backsheet to support (G) with hardware provided.
4. Tighten bolts.

### 9.19.1.4 Header Attachment

- a. Re-attach adapter to combine. Refer to Section 7 HEADER ATTACHMENT/DETACHMENT.
- b. Re-attach header to adapter. Refer to Section 8 HEADER/ADAPTER DISASSEMBLY AND ASSEMBLY.
- c. Adjust header float. Refer to Section 9.11.3 Header Float.
- d. Level header if necessary. Refer to Section 9.14 HEADER LEVELLING.

## SECTION 10. MAINTENANCE AND SERVICING

### 10 MAINTENANCE AND SERVICING

The following instructions are provided to assist the Operator in the use of the header.

Detailed maintenance, service, and parts information are contained in the Service Instruction Manual, and the Parts Catalog that are available from your MacDon Dealer.

#### 10.1 PREPARATION FOR SERVICING



#### CAUTION

To avoid personal injury, before servicing header or opening drive covers:

1. Fully lower the header. If necessary to service in the raised position, always engage lift cylinder stops.
2. Stop engine and remove key.
3. Engage park brake.
4. Wait for all moving parts to stop.

#### 10.2 RECOMMENDED SAFETY PROCEDURES

- Park on level surface when possible. Block wheels securely if combine is parked on an incline. Follow all recommendations in your Combine Operator's Manual.
- Wear close-fitting clothing and cover long hair. Never wear dangling items such as scarves or bracelets.
- Wear protective shoes with slip-resistant soles, a hard hat, protective glasses or goggles and heavy gloves.
- If more than one person is servicing the machine at the same time, be aware that rotating a driveline or other mechanically driven component by hand (for example, accessing a lube fitting) will cause drive components in other areas (belts, pulleys, and sickle) to move. Stay clear of driven components at all times.
- Be prepared if an accident should occur. Know where the first aid kit and fire extinguishers are located and how to use them.
- Keep the service area clean and dry. Wet or oily floors are slippery. Wet spots can be dangerous when working with electrical equipment. Be sure all electrical outlets and tools are properly grounded.
- Use adequate light for the job at hand.
- Replace all shields removed or opened for service.
- Use only service and repair parts made or approved by the equipment manufacturer. Substituted parts may not meet strength, design or safety requirements.
- Keep the machine clean. Never use gasoline, naphtha or any volatile material for cleaning purposes. These materials may be toxic and/or flammable.

## SECTION 10. MAINTENANCE AND SERVICING

### 10.3 MAINTENANCE SPECIFICATIONS

#### 10.3.1 RECOMMENDED TORQUES

- Tighten all bolts to the torques specified in chart unless otherwise noted throughout this manual.
- Check tightness of bolts periodically, using bolt torque chart as a guide.
- Replace hardware with the same strength bolt.
- Torque figures are valid for non-greased or non-oiled threads and heads, unless otherwise specified.
- Do not grease or oil bolts or capscrews unless specified in this manual.
- When using locking elements, increase torque values by 5%.

##### 10.3.1.1 SAE Bolts

BOLT DIA. "A" in.	NC BOLT TORQUE*			
	SAE 5		SAE 8	
	lbf-ft	N-m	lbf-ft	N-m
1/4	9	12	11	15
5/16	18	24	25	34
3/8	32	43	41	56
7/16	50	68	70	95
1/2	75	102	105	142
9/16	110	149	149	202
5/8	150	203	200	271
3/4	265	359	365	495
7/8	420	569	600	813
1	640	867	890	1205

\* Torque categories for bolts and capscrews are identified by their head markings.

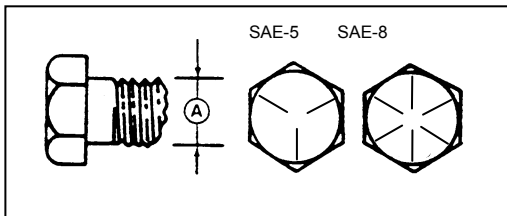

##### 10.3.1.2 Metric Bolts

BOLT DIA. "A"	STD COARSE BOLT TORQUE*			
	8.8		10.9	
	lbf-ft	N-m	lbf-ft	N-m
M3	0.4	0.5	1.3	1.8
M4	2.2	3	3.3	4.5
M5	4	6	7	9
M6	7	10	11	15
M8	18	25	26	35
M10	37	50	52	70
M12	66	90	92	125
M14	103	140	148	200
M16	166	225	229	310
M20	321	435	450	610
M24	553	750	774	1050
M30	1103	1495	1550	2100
M36	1917	2600	2710	3675

\* Torque categories for bolts and capscrews are identified by their head markings.

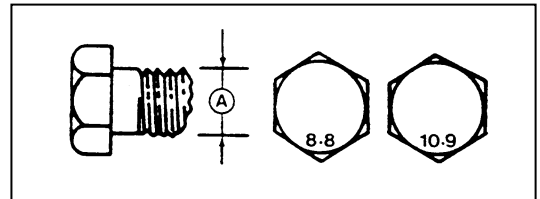



## SECTION 10. MAINTENANCE AND SERVICING

### 10.3.1.3 Flare Type Hydraulic Fittings

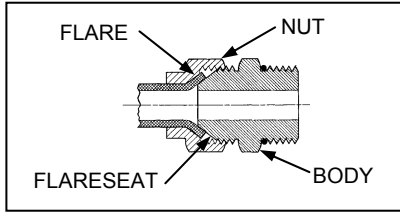

- a. Check flare and flare seat for defects that might cause leakage.
- b. Align tube with fitting before tightening.
- c. Lubricate connection and hand tighten swivel nut until snug.
- d. To prevent twisting the tube(s), use two wrenches. Place one wrench on the connector body, and with the second, tighten the swivel nut to the torque shown.

SAE NO.	TUBE SIZE O.D. (in.)	THD SIZE (in.)	NUT SIZE ACROSS FLATS (in.)	TORQUE VALUE*		RECOMMENDED TURNS TO TIGHTEN (AFTER FINGER TIGHTENING)	
				ft-lbf	N-m	Flats	Turns
3	3/16	3/8	7/16	6	8	1	1/6
4	1/4	7/16	9/16	9	12	1	1/6
5	5/16	1/2	5/8	12	16	1	1/6
6	3/8	9/16	11/16	18	24	1	1/6
8	1/2	3/4	7/8	34	46	1	1/6
10	5/8	7/8	1	46	62	1	1/6
12	3/4	1-1/16	1-1/4	75	102	3/4	1/8
14	7/8	1-3/16	1-3/8	90	122	3/4	1/8
16	1	1-5/16	1-1/2	105	142	3/4	1/8

\* The torque values shown are based on lubricated connections as in reassembly.

### 10.3.1.4 O-ring Type Hydraulic Fittings

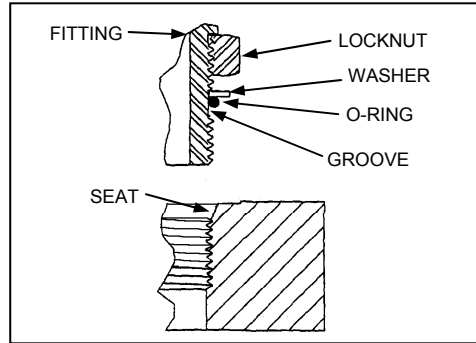

- a. Inspect O-ring and seat for dirt or obvious defects.

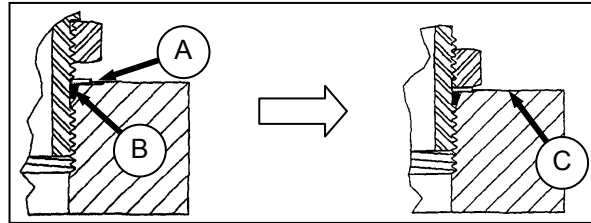

- b. On angle fittings, back off the lock nut until washer (A) bottoms out at top of groove (B) in fitting.
- c. Hand tighten fitting until back up washer (A) or washer face (if straight fitting) bottoms on part face (C) and O-ring is seated.
- d. Position angle fittings by unscrewing **no more than one turn**.
- e. Tighten straight fittings to torque shown.
- f. Tighten angle fittings to torque shown in the following table while holding body of fitting with a wrench.

SAE NO.	THD SIZE (in.)	NUT SIZE ACROSS FLATS (in.)	TORQUE VALUE*		RECOMMENDED TURNS TO TIGHTEN (AFTER FINGER TIGHTENING)	
			ft-lbf	N-m	Flats	Turns
3	3/8	1/2	6	8	3	3/8
4	7/16	9/16	9	12	4	7/16
5	1/2	5/8	12	16	5	1/2
6	9/16	11/16	18	24	6	9/16
8	3/4	7/8	34	46	8	3/4
10	7/8	1	46	62	10	7/8
12	1-1/16	1-1/4	75	102	12	1-1/16
14	1-3/16	1-3/8	90	122	14	1-3/16
16	1-5/16	1-1/2	105	142	16	1-5/16
20	1-5/8	1-7/8	140	190	20	1-5/8
24	1-7/8	2-1/8	160	217	24	1-7/8

\* The torque values shown are based on lubricated connections as in reassembly.

## SECTION 10. MAINTENANCE AND SERVICING

### 10.3.2 ROLLER CHAIN INSTALLATION



#### CAUTION

Stop engine and remove key from ignition before leaving Operator's seat for any reason. A child or even a pet could engage an idling machine.

- Locate ends of chain on sprocket.

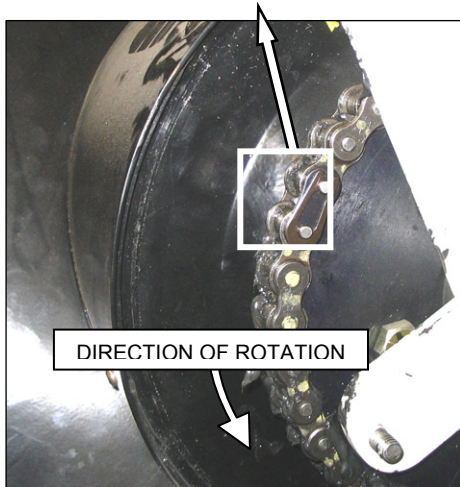
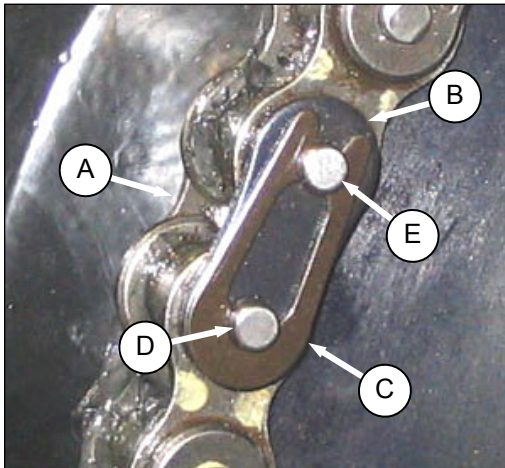

- Install pin connector (A) into chain, preferably from the sprocket backside.
- Install connector (B) onto pins.
- Install spring clip (C) onto front pin (D) with closed end of clip in direction of sprocket rotation.
- Locate one leg of clip in groove of aft pin (E).
- Press other leg of spring clip over face of aft pin (E) until it slips into groove. Do not press clip lengthwise from closed end.
- Ensure clip is seated in grooves of pins.

### 10.3.3 SEALED BEARING INSTALLATION

- Clean shaft and coat with rust preventative.

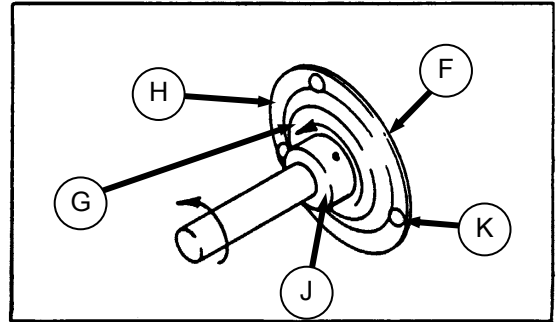

- Install flangette (F), bearing (G), second flangette (H) and lock collar (J).

#### NOTE

*The locking cam is only on one side of the bearing.*

- Install (but do not tighten) the flangette bolts (K).
- When the shaft is correctly located, lock the lock collar with a punch.

#### NOTE

*The collar should be locked in the same direction the shaft rotates. Tighten the set screw in the collar.*

- Tighten the flangette bolts.
- Loosen the flangette bolts on the mating bearing one turn and re-tighten. This will allow the bearing to line up.

## SECTION 10. MAINTENANCE AND SERVICING

### 10.3.4 RECOMMENDED FLUIDS AND LUBRICANTS

Your machine can operate at top efficiency only if clean lubricants are used.

- Use clean containers to handle all lubricants.
- Store in an area protected from dust, moisture, and other contaminants.

LUBRICANT	SPEC.	DESCRIPTION	USE	CAPACITIES
Grease	SAE Multi-Purpose	High Temp. Extreme Pressure (EP2) Performance With 1% Max Molybdenum Disulphide (NLGI Grade 2) Lithium Base	As Required Unless Otherwise Specified.	---
		High Temp. Extreme Pressure (EP) Performance With 10% Max Molybdenum Disulphide (NLGI Grade 2) Lithium Base	Driveline Slip-Joints	---
Gear Lubricant	SAE 85W-140	API Service Class GL-5	Wobble Box	2.3 quarts (2.2 liters)
			Main Drive Gearbox	5 pints (2.5 liters)
Hydraulic Oil	SAE 15W-40	Compliant With SAE Specs For API Class SJ And CH-4 Engine Oil	Header Drive Systems Reservoir	16 gallons. US (60 liters)



## SECTION 10. MAINTENANCE AND SERVICING

### 10.3.5 CONVERSION CHART

QUANTITY	INCH-POUND UNITS		FACTOR	SI UNITS (METRIC)	
	UNIT NAME	ABBR.		UNIT NAME	ABBR.
Area	acres	acres	$\times 0.4047 =$	hectares	ha
Flow	US gallons per minute	gpm	$\times 3.7854 =$	liters per minute	L/min
Force	pounds force	lbf	$\times 4.4482 =$	Newtons	N
Length	inch	in.	$\times 25.4 =$	millimeters	mm
	foot	ft	$\times 0.305 =$	meters	m
Power	horsepower	hp	$\times 0.7457 =$	kilowatts	kW
Pressure	pounds per square inch	psi	$\times 6.8948 =$	kilopascals	kPa
			$\times .00689 =$	megapascals	MPa
Torque	pound feet or foot pounds	lbf·ft or ft·lbf	$\times 1.3558 =$	newton meters	N·m
	pound inches or inch pounds	lbf·in. or in·lbf	$\times 0.1129 =$	newton meters	N·m
Temperature	degrees Fahrenheit	°F	$(^{\circ}\text{F} - 32) \times 0.56 =$	Celsius	°C
Velocity	feet per minute	ft/min	$\times 0.3048 =$	meters per minute	m/min
	feet per second	ft/s	$\times 0.3048 =$	meters per second	m/s
	miles per hour	mph	$\times 1.6063 =$	kilometers per hour	km/h
Volume	US gallons	US gal.	$\times 3.7854 =$	liters	L
	ounces	oz.	$\times 29.5735 =$	milliliters	ml
	cubic inches	in. <sup>3</sup>	$\times 16.3871 =$	cubic centimeters	cm <sup>3</sup> or cc
Weight	pounds	lb	$\times 0.4536 =$	kilograms	kg

## SECTION 10. MAINTENANCE AND SERVICING

### 10.4 ENDSHIELDS AND COVERS

#### 10.4.1 ENDSHIELDS

Single knife headers are fitted with a hinged endshield on the LH end of the header for easy access to the header drive.

The RH end is not hinged, but is still removable.

Double knife headers are fitted with hinged endshields on both ends of the header.

##### 10.4.1.1 Hinged

- a. To open the hinged endshield, press against latch in opening at (A) on inboard side of endsheet.

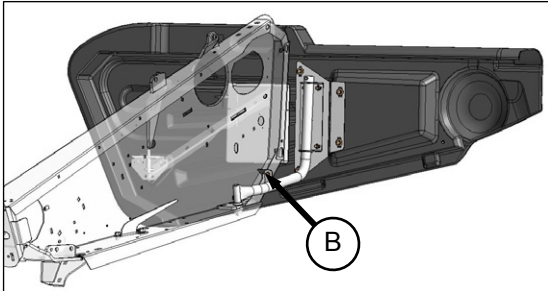
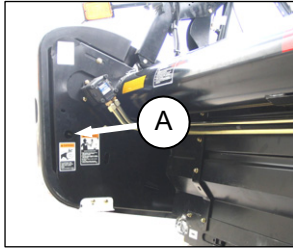

- b. Pull shield away from header and swing it out and back behind the endsheet until the latch (B) engages the hook on the endsheet.



- c. To close shield, lift latch (B) and swing the shield forward until the front engages the crop divider (C).



- d. Push in shield where shown (opposite latch) and shield will self-latch.

##### 10.4.1.1.1 Adjustments

###### NOTE

*Plastic endshields are subject to expansion or contraction depending on large temperature variations. Latch pin can be adjusted to compensate for dimensional changes.*

- a. Open driveshield.

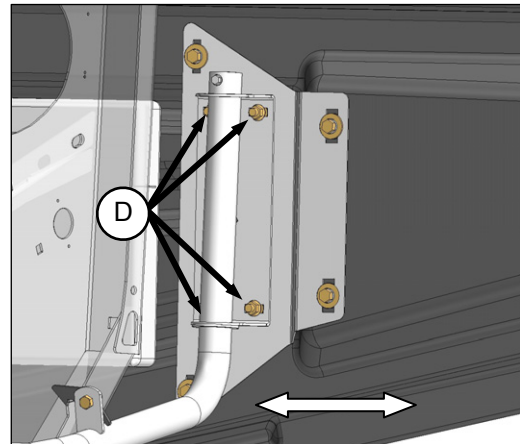

- b. Loosen bolts (D) on support.

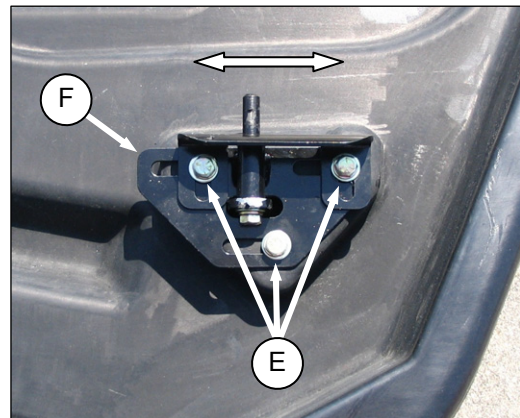

- c. Loosen bolts (E) on latch assembly (F).

*(continued next page)*

## SECTION 10. MAINTENANCE AND SERVICING

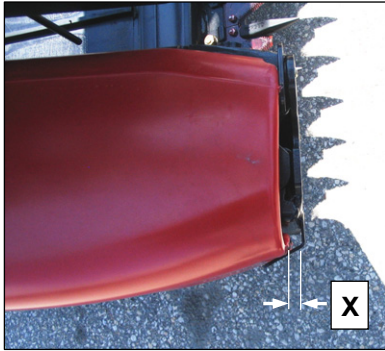

- d. Adjust the endshield to achieve the gap 'X' between the front end of the shield and the header frame in accordance with the following chart.

TEMPERATURE Degrees F (C)	GAP 'X' Inches (mm)
25 (-4)	1.1 (28)
45 (7)	1.0 (24)
65 (18)	0.79 (20)
85 (29)	0.64 (16)
105 (41)	0.5 (12)
125 (52)	0.32 (8)
145 (63)	0.16 (4)
165 (89)	0

- e. Tighten bolts (D) and (E).

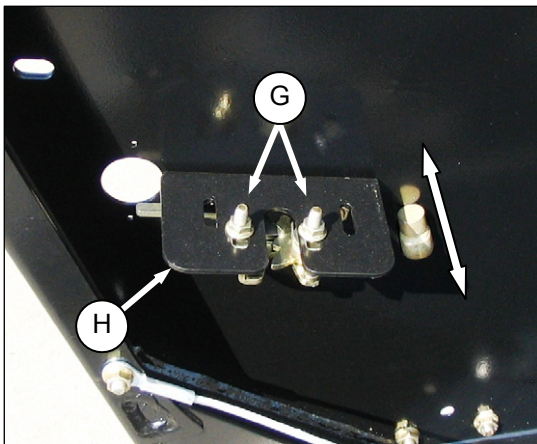
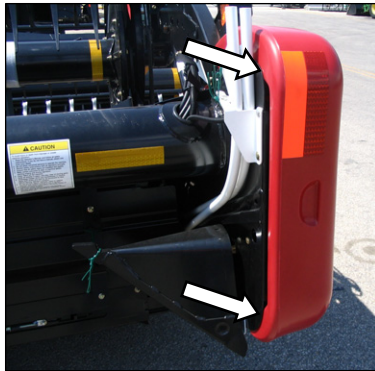

- f. To achieve a snug fit between the aft end of the shield and header frame, loosen bolts (G) and adjust the latch (H) to reposition the shield.

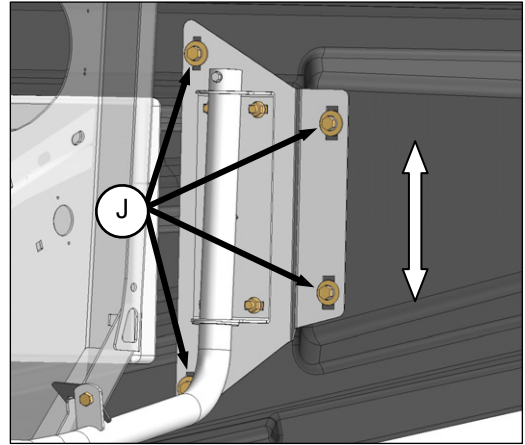

- g. Loosen bolts (J) on endshield support and adjust endshield to align with endsheet as shown above.  
h. Tighten bolts (G) and (J).  
i. Close endshield.

### 10.4.1.1.2 Removal

- a. Open endshield.

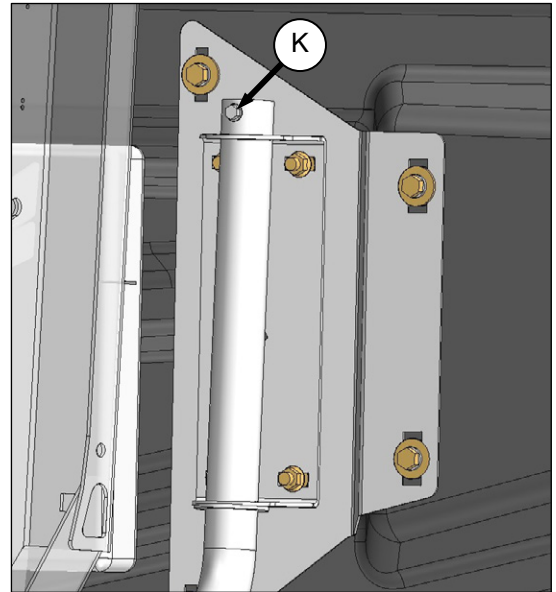

- b. Remove screw (K) at top of support tube.  
c. Lift endshield off support tube.

## SECTION 10. MAINTENANCE AND SERVICING

### 10.4.1.2 Non-Hinged

- a. To remove the endshield, press against latch in opening at (A) on inboard side of endsheet.

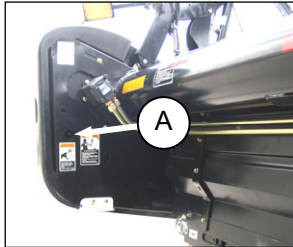

- b. Lift up on shield, pull out and back to remove shield.

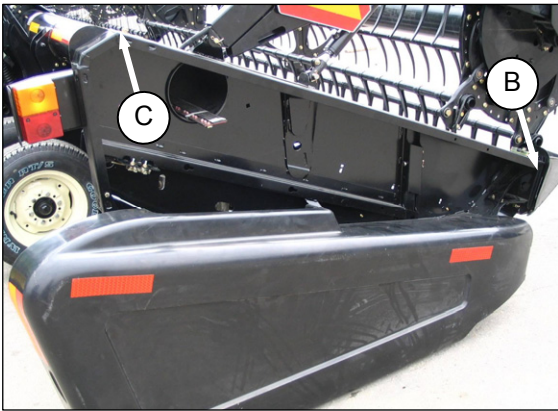

- c. To install shield, locate forward end in crop divider (B) and position shield over endsheet. Pin (C) at top of endsheet must engage shield.



- d. Push in shield where shown (opposite latch) and shield will self-latch.

### 10.4.1.2.1 Adjustments

#### NOTE

*Plastic endshields are subject to expansion or contraction depending on large temperature variations. Latch pin can be adjusted to compensate for dimensional changes.*

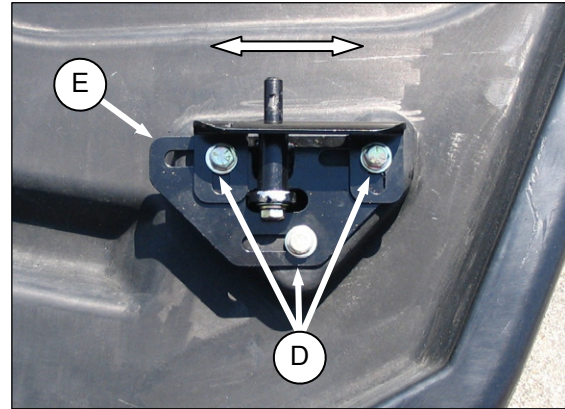

- a. Remove endshield.  
b. Loosen bolts (D).

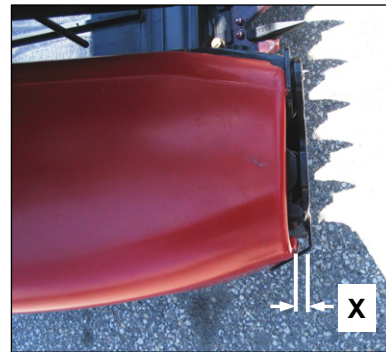

- c. Adjust the pin assembly (E) to achieve the gap 'X' between the front end of the shield and the header frame in accordance with the following chart.

TEMPERATURE Degrees F (C)	GAP 'X' Inches (mm)
25 (-4)	1.1 (28)
45 (7)	1.0 (24)
65 (18)	0.79 (20)
85 (29)	0.64 (16)
105 (41)	0.5 (12)
125 (52)	0.32 (8)
145 (63)	0.16 (4)
165 (89)	0

- d. Tighten bolts (D).

*(continued next page)*



## SECTION 10. MAINTENANCE AND SERVICING

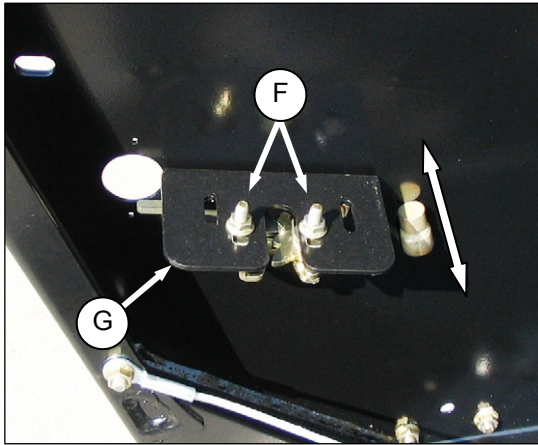
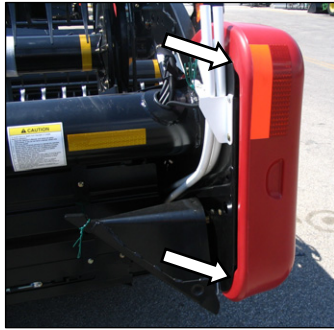

- e. To achieve a snug fit between the aft end of the shield and header frame, loosen bolts (F) and adjust the latch (G) to reposition the shield.
- f. Tighten bolts (F).

### 10.4.2 LINKAGE COVER (FD70 FLEXDRAPER ONLY)

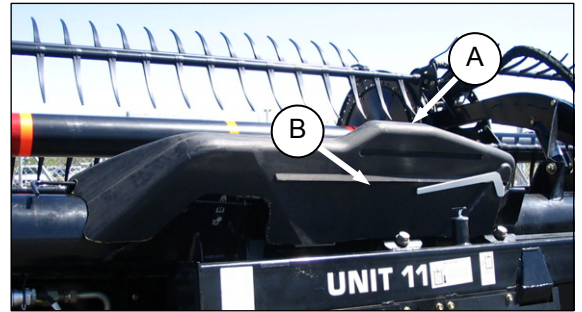

- a. To remove the balance linkage covers (A), remove screw (B) and lift outboard end of cover.



- b. Rotate upwards until inboard end can be lifted off.

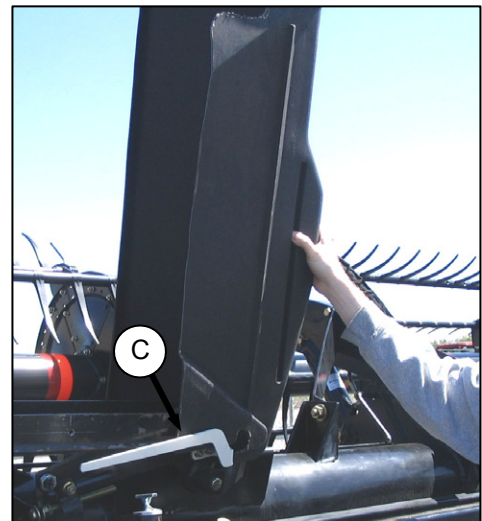

- c. To install the cover, locate inboard end over linkage and behind indicator bar (C).
- d. Lower cover until secure and against the header tube.
- e. Install screw (B).

## SECTION 10. MAINTENANCE AND SERVICING

### 10.5 LUBRICATION



#### CAUTION

To avoid personal injury, before servicing header or opening drive covers, follow procedures in Section 10.1 PREPARATION FOR SERVICING.

Refer to Section 10.3.4 Recommended Fluids and Lubricants for recommended greases.

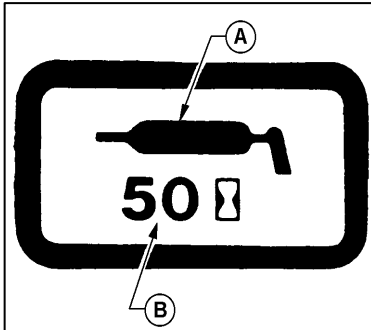

SAMPLE GREASE DECAL

The greasing points are marked on the machine by decals showing a grease gun (A), and grease interval (B) in hours of operation. Log hours of operation and use the "Maintenance Checklist" provided to keep a record of scheduled maintenance. Refer to Section 10.17 MAINTENANCE SCHEDULE.

#### 10.5.1 GREASING PROCEDURE

- a. Wipe grease fitting with a clean cloth before greasing, to avoid injecting dirt and grit.
- b. Inject grease through fitting with grease gun until grease overflows fitting, except where noted.
- c. Leave excess grease on fitting to keep out dirt.
- d. Replace any loose or broken fittings immediately.
- e. If fitting will not take grease, remove and clean thoroughly. Also clean lubricant passageway. Replace fitting if necessary.

#### 10.5.2 LUBRICATION POINTS

Refer to the illustrations on the following pages to identify the various locations that require lubrication.

## SECTION 10. MAINTENANCE AND SERVICING

### 10.5.2 LUBRICATION POINTS (Cont'd)

**NOTE:** REEL BEARING LUBE INTERVALS - 500 HOURS OR ONCE PER SEASON - WHICHEVER OCCURS FIRST.

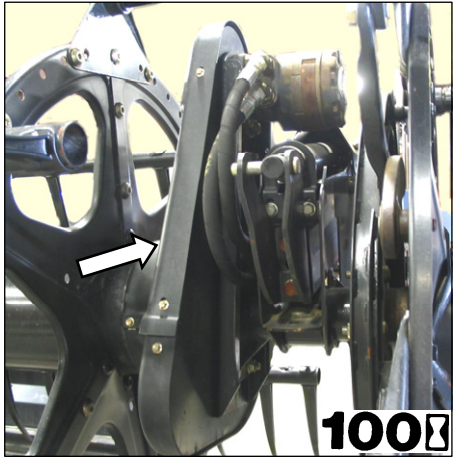

REEL DRIVE CHAIN (1 PLC)  
DOUBLE REEL SHOWN -  
SINGLE REEL SIMILAR

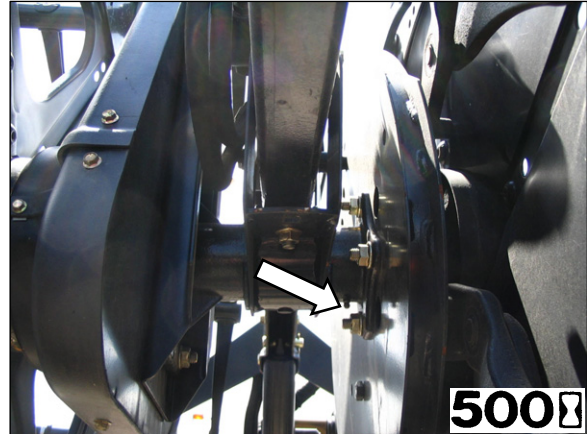

REEL CENTER BEARING (1 PLC)  
DOUBLE REEL ONLY



REEL SHAFT RH BEARING (1 PLC)

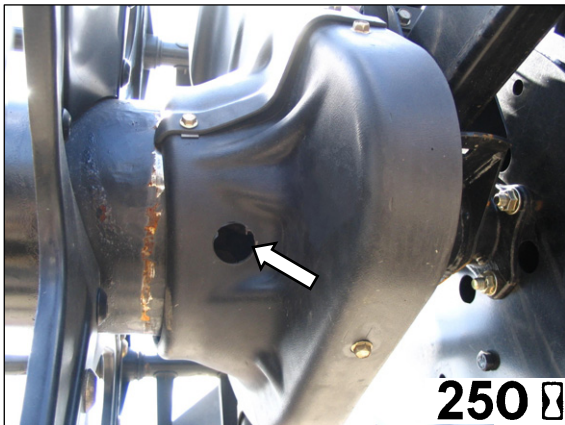
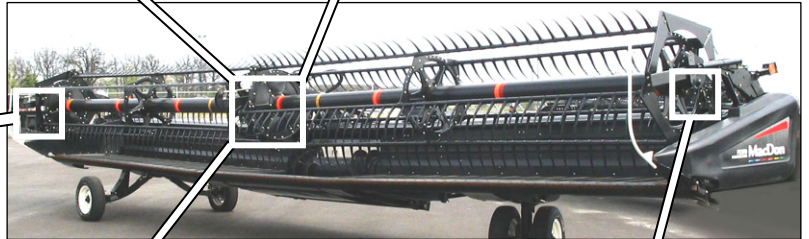

REEL UNIVERSAL (1 PLC)



REEL SHAFT LH BEARING (1 PLC)

U-JOINT HAS AN EXTENDED LUBRICATION CROSS AND BEARING KIT. STOP GREASING WHEN GREASING BECOMES DIFFICULT OR IF U-JOINT STOPS TAKING GREASE. **OVERGREASING WILL DAMAGE U-JOINT.** 6-8 PUMPS IS SUFFICIENT AT FIRST GREASE (FACTORY). DECREASE GREASE INTERVAL AS U-JOINT WEARS AND REQUIRES MORE THAN 6 PUMPS.



## SECTION 10. MAINTENANCE AND SERVICING

### 10.5.2 LUBRICATION POINTS (Cont'd)

**NOTE:** LUBE INTERVALS - 250 HOURS OR ONCE PER SEASON - WHICHEVER OCCURS FIRST.

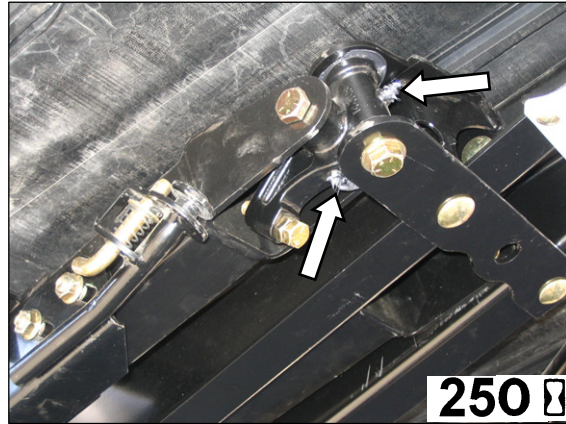

RIGHT SIDE -WHEEL AXLE (2 PLC)

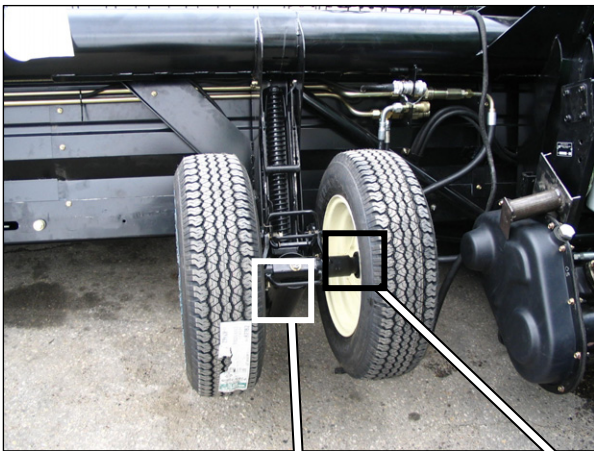

LEFT SIDE WHEELS

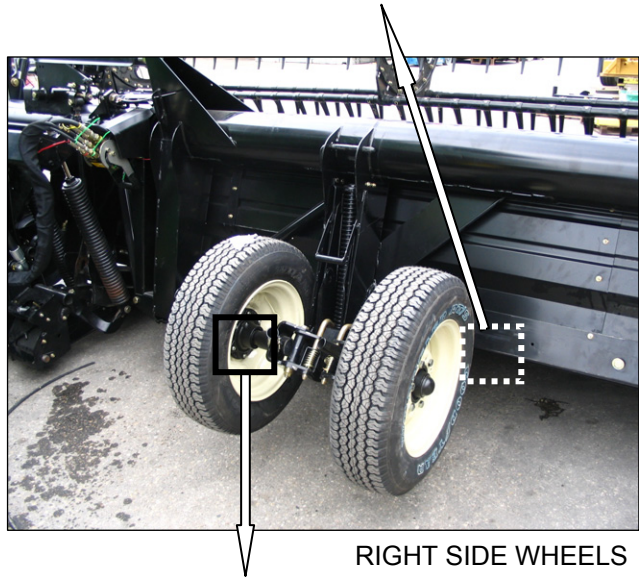

RIGHT SIDE WHEELS



LEFT SIDE - WHEEL PIVOT (1 PLC)



WHEEL BEARINGS (2 PLC BOTH SIDES)



## SECTION 10. MAINTENANCE AND SERVICING

### 10.5.2 LUBRICATION POINTS (Cont'd)

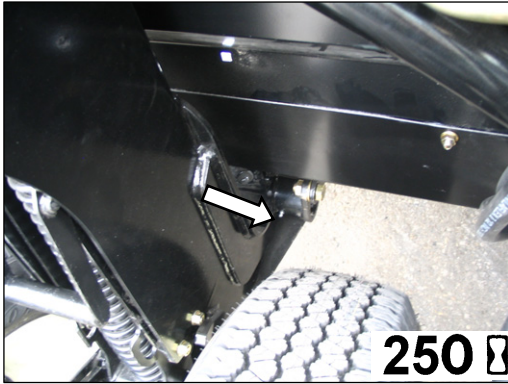

FRAME/WHEEL PIVOT (1 PLC) BOTH SIDES

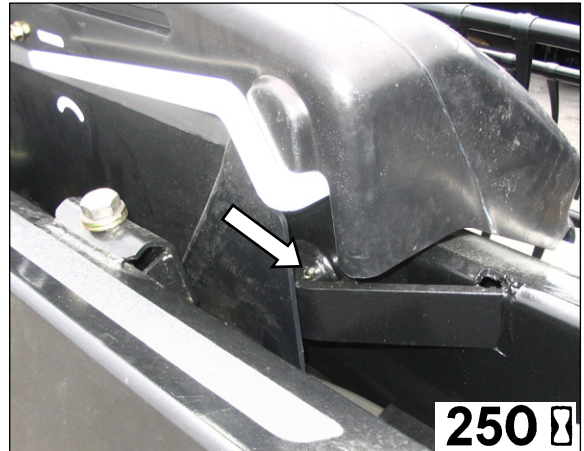

FLEX LINKAGE (FLEX HEADER ONLY)  
BOTH SIDES

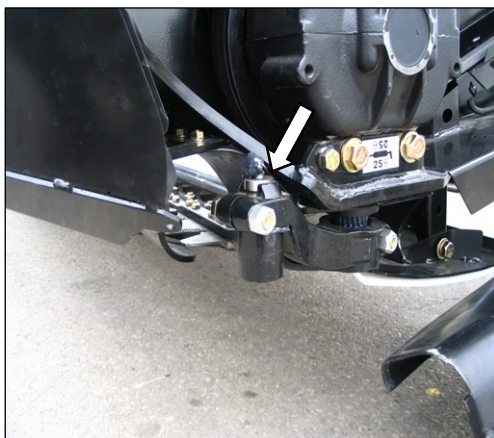
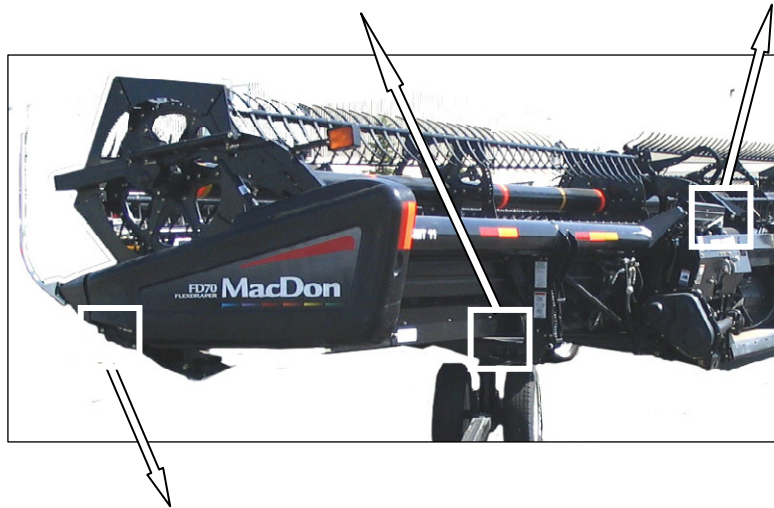

SICKLE HEAD  
(SINGLE KNIFE - 1 PLC  
DOUBLE KNIFE - 2 PLCS)

To prevent binding and/or excessive wear caused by sickle pressing on guards, do not over grease. If more than 6 to 8 pumps of the grease gun are required to fill the cavity, replace the seal in the sickle head.

Check for signs of excessive heating on first few guards after greasing. If required, relieve pressure by depressing check-ball in grease fitting.

# SECTION 10. MAINTENANCE AND SERVICING

## 10.5.2 LUBRICATION POINTS (Cont'd)

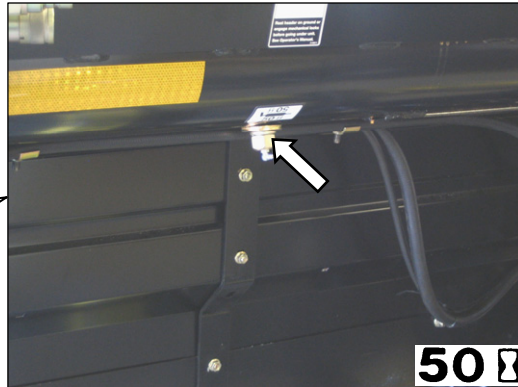
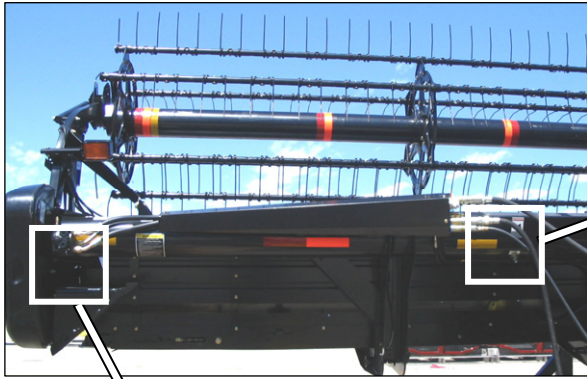

KNIFE DRIVE SHAFT - DK (BOTH SIDES)  
15 PUMPS MINIMUM

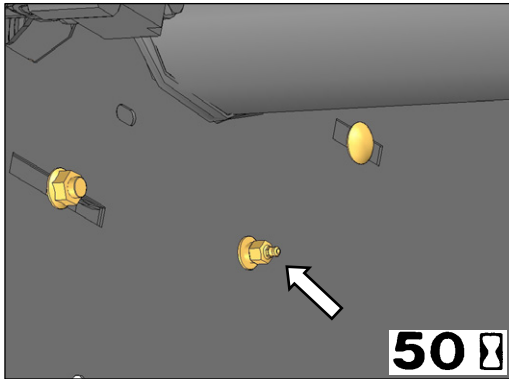

KNIFE DRIVE BEARING - DK (BOTH SIDES)

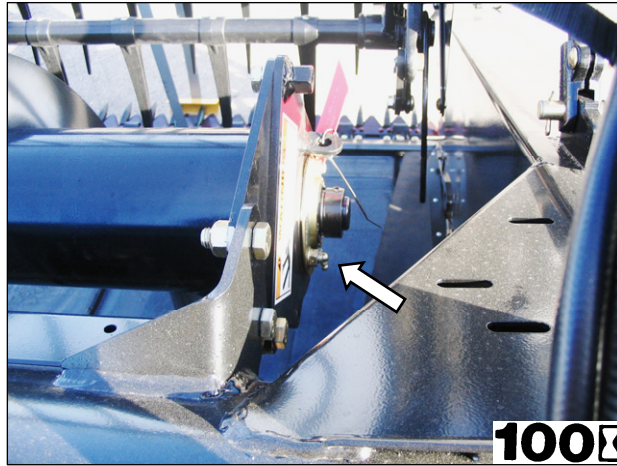

UPPER CROSS AUGER - 1 PLC

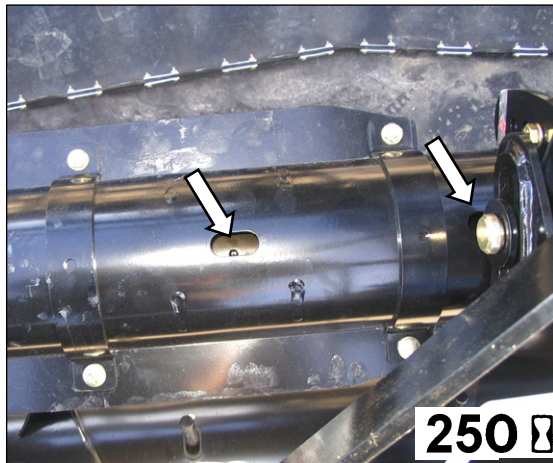

UPPER CROSS AUGER - 2 PLCS

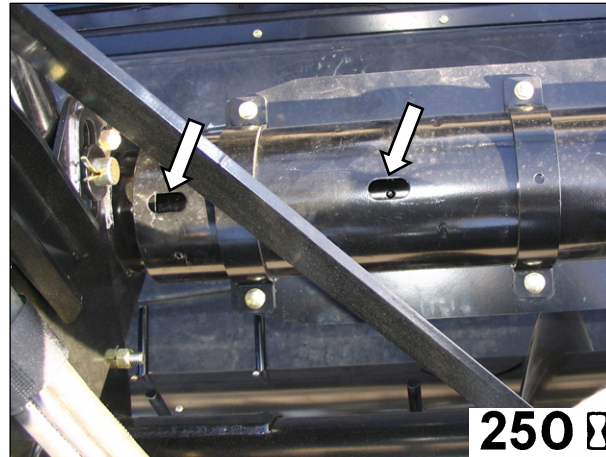

UPPER CROSS AUGER - 2 PLCS



## SECTION 10. MAINTENANCE AND SERVICING

### 10.5.2 LUBRICATION POINTS (Cont'd)

High Temp. Extreme Pressure  
(EP2) Performance With 1%  
Max Molybdenum Disulphide  
(NLGI Grade 2).Lithium Base

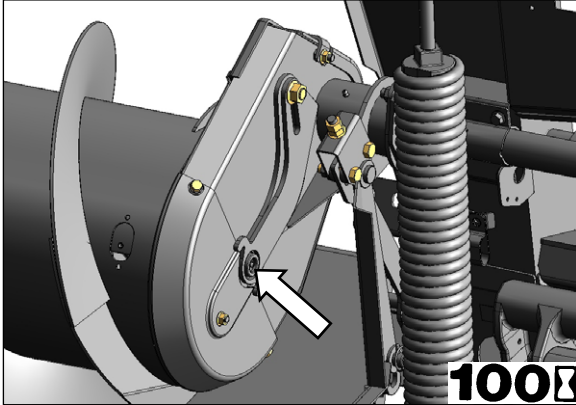

AUGER BEARING

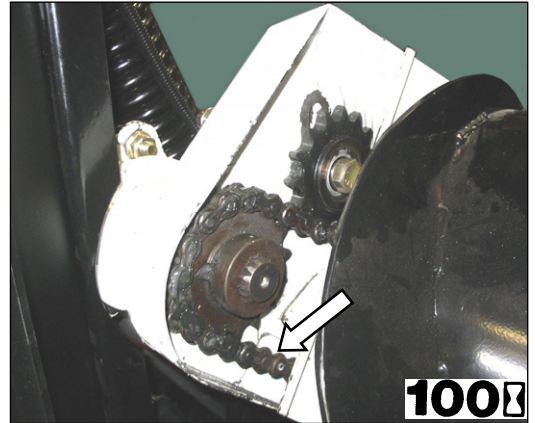

AUGER DRIVE CHAIN  
SEE SECTION 10.9.2

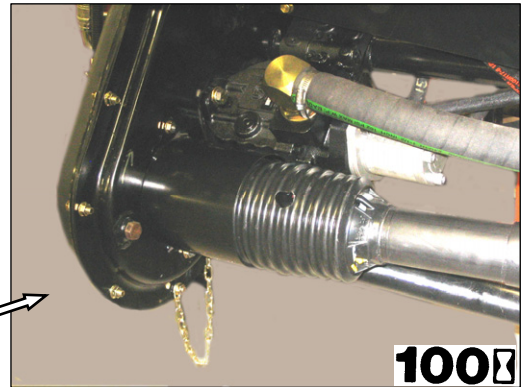
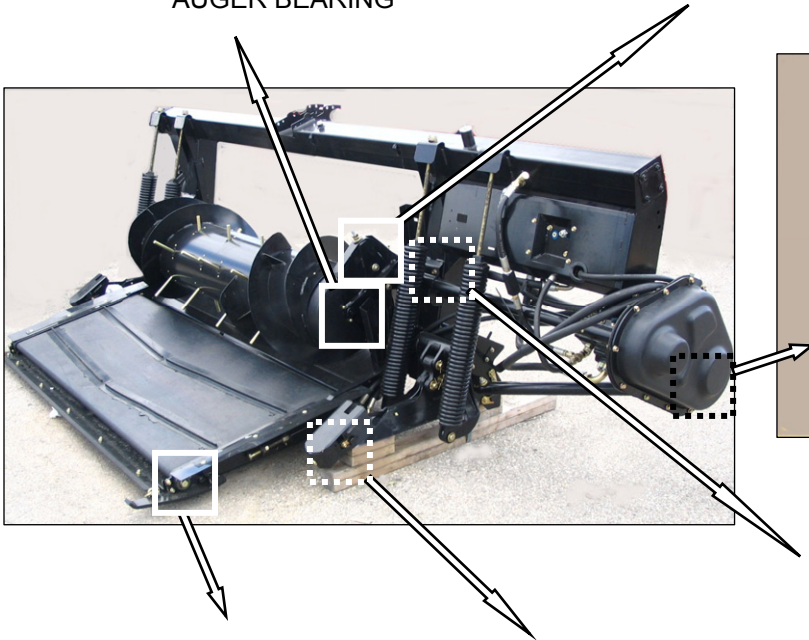

MAIN DRIVE GEARBOX  
SEE SECTION 10.5.5

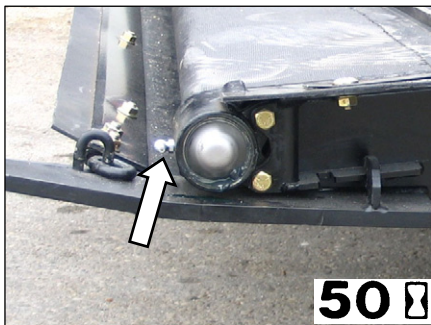

IDLER ROLLER

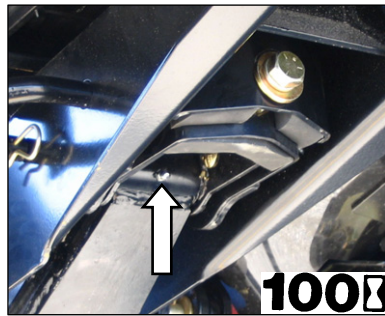

VIBRATION DAMPER PIVOT  
BOTH SIDES

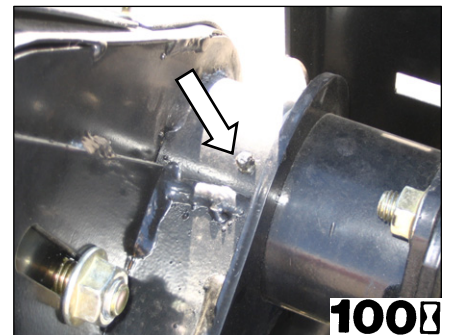

AUGER DRIVE-SHAFT



# SECTION 10. MAINTENANCE AND SERVICING

## 10.5.2 LUBRICATION POINTS (Cont'd)

High Temp. Extreme Pressure (EP2) Performance With 1% Max Molybdenum Disulphide (NLGI Grade 2),Lithium Base

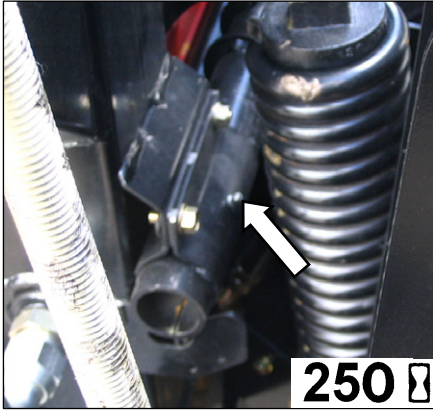

AUGER PIVOT - BOTH SIDES

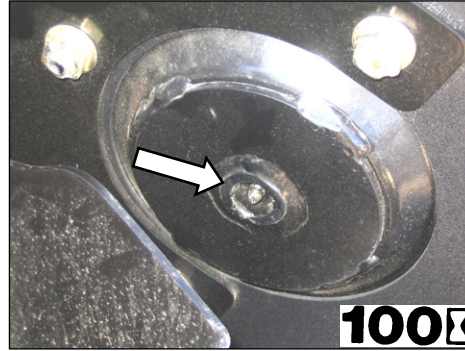

AUGER BEARING

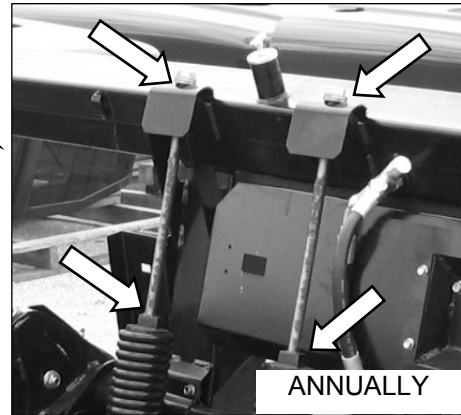
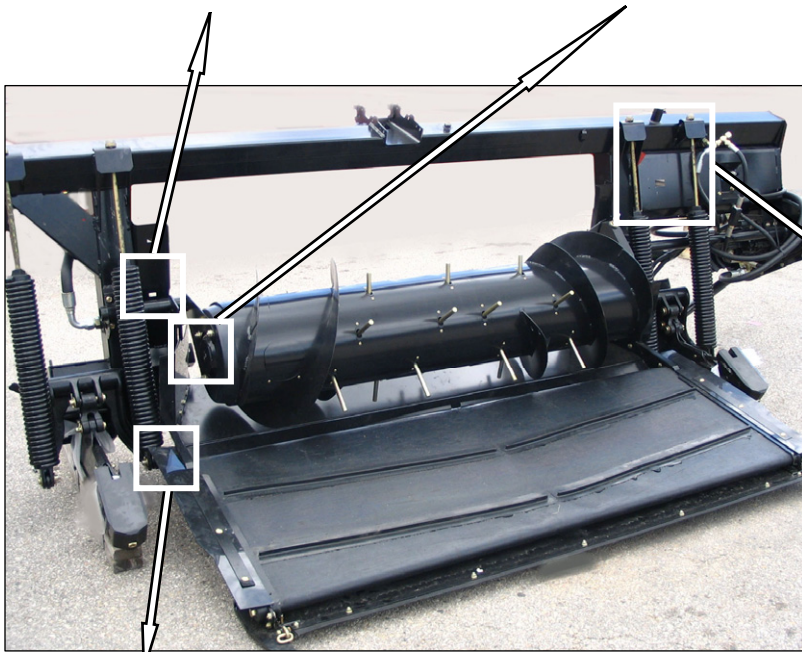

FLOAT ADJUSTERS  
2 PLCS, BOTH SIDES

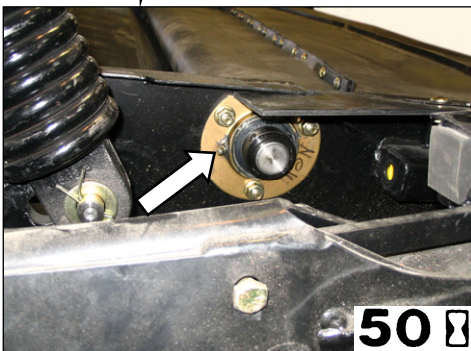

DRIVE ROLLER BEARING

# SECTION 10. MAINTENANCE AND SERVICING

## 10.5.2 LUBRICATION POINTS (Cont'd)

High Temp. Extreme Pressure  
(EP2) Performance With 1%  
Max Molybdenum Disulphide  
(NLGI Grade 2).Lithium Base



DRIVELINE SLIP JOINT

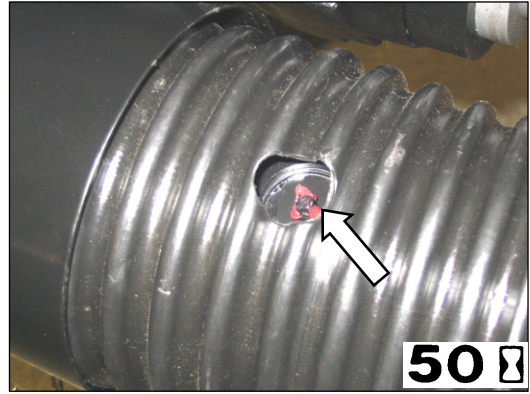

DRIVE UNIVERSAL - 2 PLCS

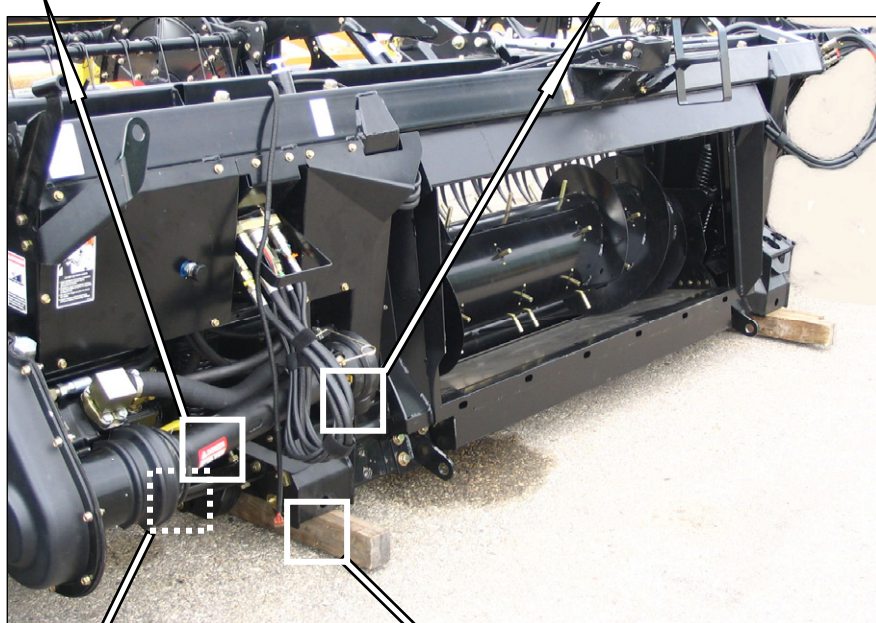

GUARD - 2 PLCS

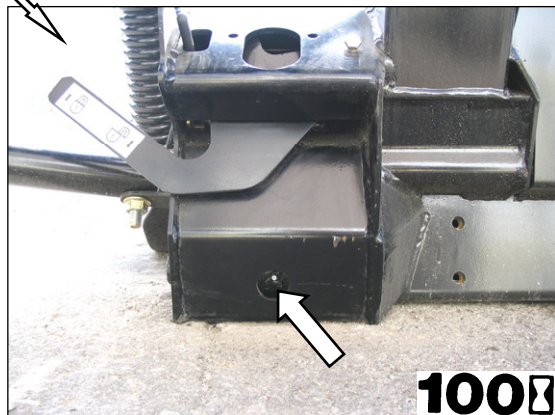

FLOAT PIVOT - 2 PLCS



## SECTION 10. MAINTENANCE AND SERVICING

### 10.5.3 OILING REQUIREMENTS

Refer to the following illustration for identifying the various locations that require lubrication. See Section 10.3.4 Recommended Fluids and Lubricants, for proper oil.

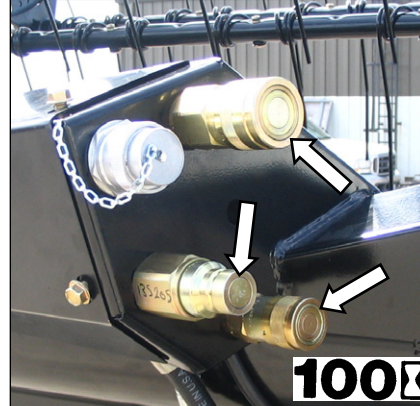

LUBRICATE WITH WD40 OR EQUIVALENT

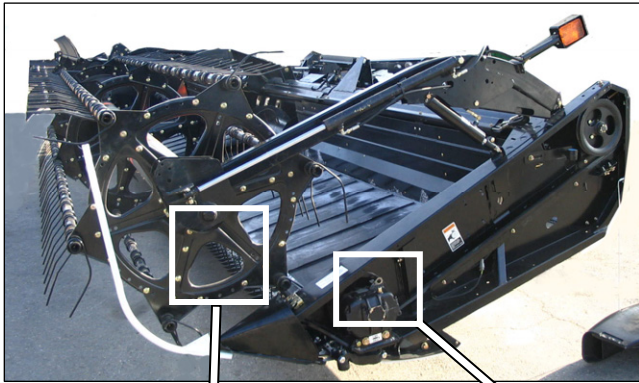

OIL SICKLE DAILY EXCEPT  
IN SANDY SOIL

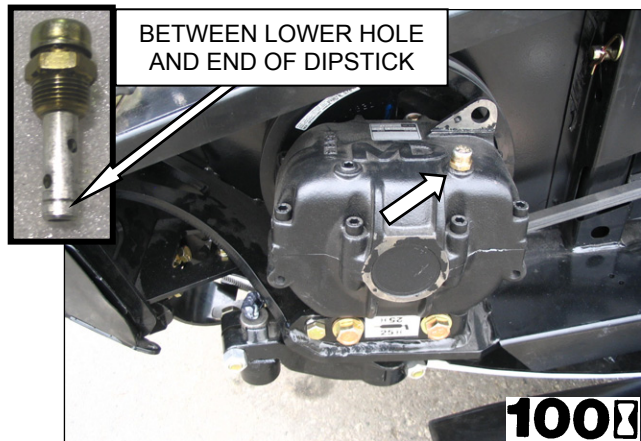

WOBBLE BOX (CHECK OIL LEVEL WITH  
TOP OF WOBBLE BOX HORIZONTAL)



## SECTION 10. MAINTENANCE AND SERVICING

### 10.5.4 AUGER DRIVE CHAIN LUBRICATION

Lubricate auger drive chain every 100 hours. This can be done with the adapter attached to the combine, but it is easier if the adapter is detached.

Refer to following illustration and proceed as follows:

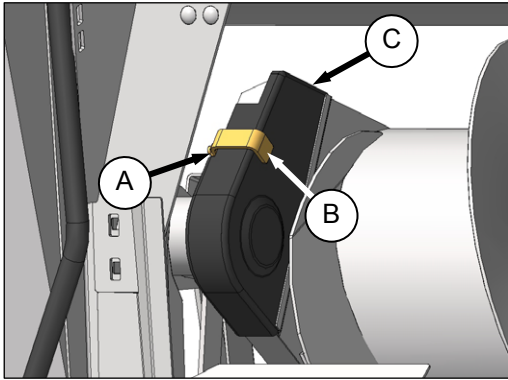

- a. Loosen nut (A) and remove clip (B) and cover (C).

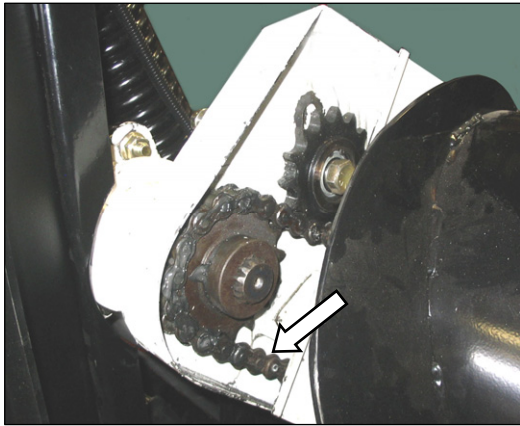

- b. Liberally apply grease to chain.
- c. Reinstall cover (B) with clip (C) and tighten nut (A).

### 10.5.5 MAIN DRIVE GEARBOX LUBRICATION

#### 10.5.5.1 Oil Level

Check oil level every 100 hours as follows:



#### CAUTION

**Stop engine and remove key from ignition before leaving Operator's seat for any reason. A child or even a pet could engage an idling machine.**

- a. Set cutterbar to working position.

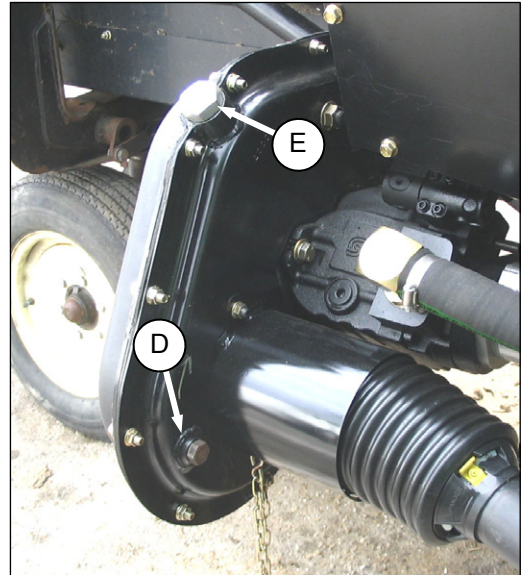

- b. Remove drain plug (D). Level should be to bottom of drain hole.
- c. Check plug for accumulation of filings, and clean if necessary.
- d. Replace drain plug and add oil if required. See next section.

#### 10.5.5.2 Adding Oil

- a. Lower cutterbar to ground. Gearbox must be in working position.
- b. Remove drain plug (D) and filler plug (E).
- c. Add SAE 85W-140 oil at (E) until it runs out of drain hole.
- d. Replace drain plug and filler plug.

## SECTION 10. MAINTENANCE AND SERVICING

### 10.5.5.3 Changing Gearbox Lubricant

#### NOTE

Change main drive gearbox lubricant after the first 50 hours of operation and every 1000 hours (or 3 years) thereafter.

- a. Lower cutterbar to ground.
- b. Position gearbox drain to lowest point as follows:

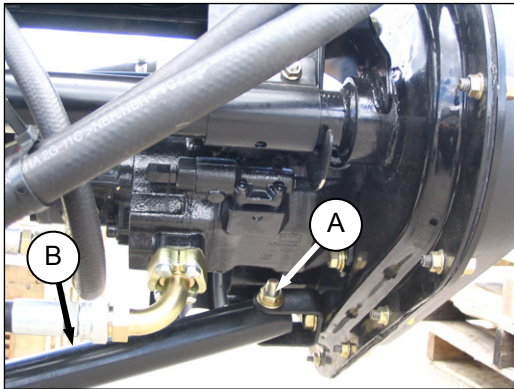

1. Remove bolt (A) securing brace (B) to gearbox and lower brace away from gearbox.

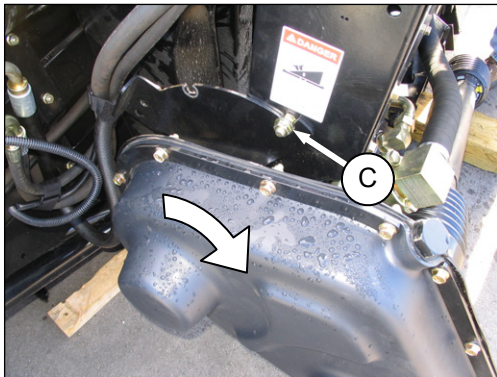

2. Loosen nut (C) and move bolt out of working position slot. Rotate gearbox into header until drain (D) is at lowest point.
- c. Place a suitable container [approx. 1 US gallon (4 liters)] under gearbox drain to collect oil.

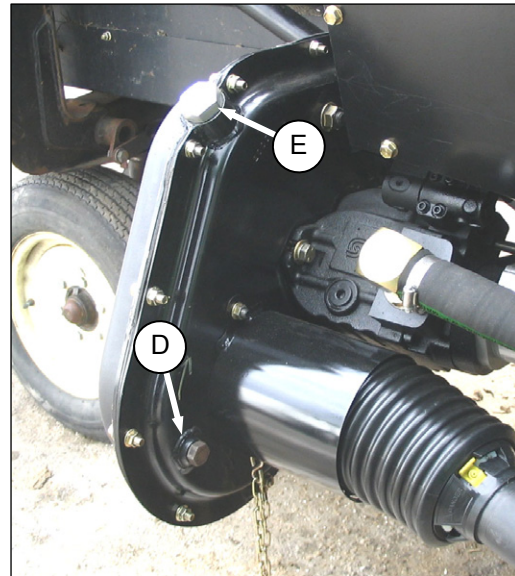

- d. Remove drain plug (D) and filler plug (E) and allow oil to drain.
- e. Reposition gearbox to working position, tighten bolt (C) and reinstall brace (B).
- f. Add SAE 85W-140 oil at (E) until it runs out of drain hole (D). Gearbox holds approximately 5 pints U.S. (2.5 liters).
- g. Replace drain plug and filler plug.

## SECTION 10. MAINTENANCE AND SERVICING

### 10.6 HYDRAULICS

The CA20 Combine Adapter's hydraulic system provides oil for the header draper and knife drives as well as the adapter feed draper.

Reel hydraulics are provided by the combine.

#### 10.6.1 RESERVOIR

The adapter frame is used as a reservoir. Refer to Section 10.3.4 Recommended Fluids and Lubricants, for proper oil.

##### 10.6.1.1 Oil Level

Check oil level every 25 hours at sights (A) and (B) with cutterbar just touching ground. Check when oil is cold and with center-link retracted.

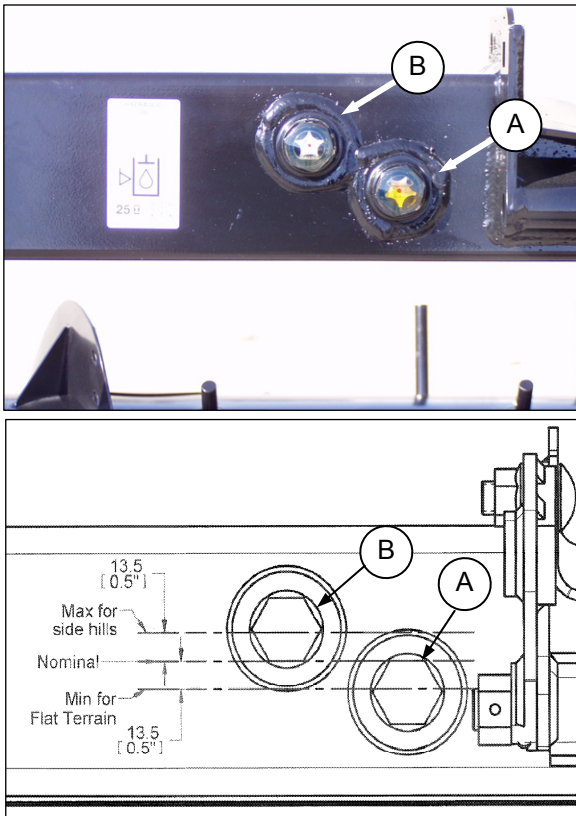

**Nominal – Normal Terrain:** Maintain level so lower sight (A) is full and upper sight (B) is empty.

**Maximum – Hilly Terrain:** Maintain level so sight (A) is full and sight (B) is up to 1/2 filled.

**Minimum – Level Ground:** For slopes of 6° or less, oil level may be kept slightly lower if desired. Maintain level so sight (A) is ½ filled or higher.

#### NOTE

When ambient temperatures are above 35° C (95° F), to prevent overflow at breather under operating temperatures, it may be necessary to lower oil level slightly.

#### 10.6.1.2 Adding Hydraulic Oil



### CAUTION

Stop engine and remove key from ignition before leaving Operator's seat for any reason. A child or even a pet could engage an idling machine.

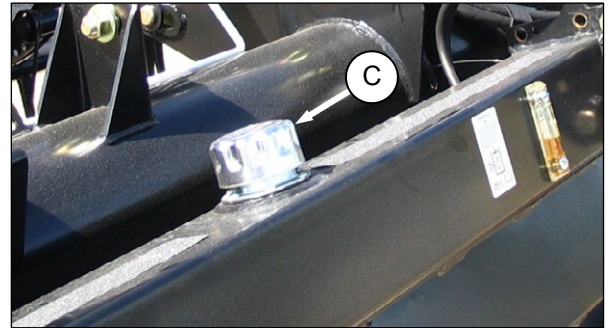

- Turn filler cap (C) counter clockwise until loose and remove cap.
- Add warm (room temperature) SAE 15W-40 oil to required level. Refer to Section 10.3.4 Recommended Fluids and Lubricants, for proper oil.

#### IMPORTANT

Warm (room temperature) oil will flow through the screen better than cold oil. DO NOT REMOVE THE SCREEN.

- Reinstall filler cap. Hand tighten.



## SECTION 10. MAINTENANCE AND SERVICING

### 10.6.1.3 Changing Hydraulic Oil Reservoir

#### NOTE

Change hydraulic oil every 1000 hours or 3 years.



There is a drain plug at the bottom of each side frame.

- Detach header from adapter. Refer to Section 8 HEADER/ADAPTER DISASSEMBLY AND ASSEMBLY.
- Detach adapter from combine. Support adapter on blocks. Refer to Section 7 HEADER ATTACHMENT/DETACHMENT.
- Place a suitable container (at least 16 gal. US) under adapter drain to collect oil.

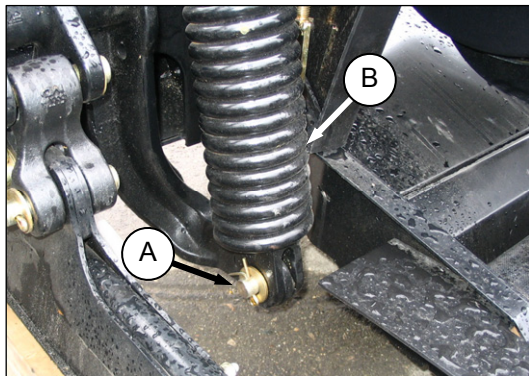

- For access to the drain plugs, remove pin (A) from lower end of float spring (B) and move float spring away from work area.

#### NOTE

If float spring is tensioned, turn adjuster bolts as required. Section 9.11.3 Header Float.

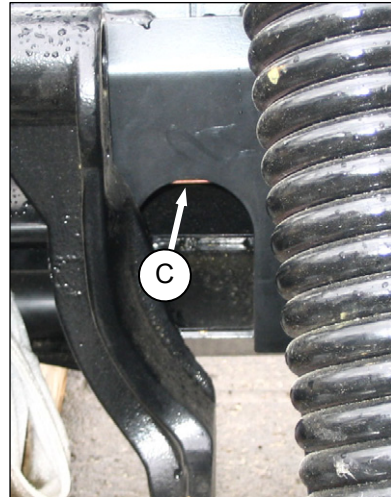

- Using a 1½" hex socket with extension, remove drain plug (C).
- Replace drain plugs (qty 2) when reservoir is empty and fill with 16 gallons U.S. (60 liters) of clean SAE 15W-40 oil. Refer to previous section for filling procedures.
- Reposition float springs (B) and secure with pins (A).
- Readjust float spring tension if released as per above note.

## SECTION 10. MAINTENANCE AND SERVICING

### 10.6.2 HYDRAULIC OIL FILTER

#### NOTE

Change hydraulic oil filter after the first 50 hours of operation and every 250 hours thereafter. Part #151975 can be obtained from your MacDon Dealer.

To change the hydraulic oil filter, refer to following illustrations and proceed as follows:



#### CAUTION

Stop engine and remove key from ignition before leaving Operator's seat for any reason. A child or even a pet could engage an idling machine.

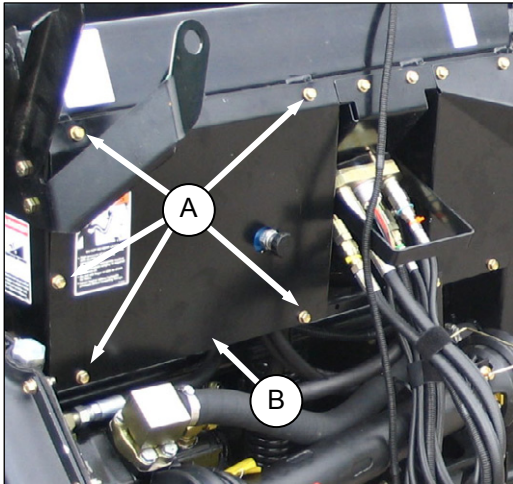

- a. Remove five screws (A) and remove panel (B).

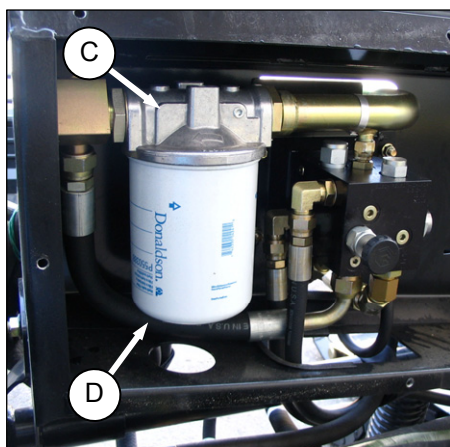

- b. Clean around filter head (C).  
c. Remove spin-off filter (D) and clean gasket surface of filter head.  
d. Apply a thin film of clean oil to the gasket on new filter.

- e. Turn the filter onto the mount until gasket contacts filter head. Tighten filter an additional  $\frac{1}{2}$  to  $\frac{3}{4}$  turn by hand.

#### IMPORTANT

Do not use a filter wrench to install the filter. Over-tightening can damage gasket and filter.

- f. Reinstall panel (B) with screws (A).

### 10.6.3 HOSES AND LINES

Check hydraulic hoses and lines daily for signs of leaks.



#### WARNING

- Avoid high-pressure fluids. Escaping fluid can penetrate the skin causing serious injury. Relieve pressure before disconnecting hydraulic lines. Tighten all connections before applying pressure. Keep hands and body away from pin-holes and nozzles which eject fluids under high pressure.
- If ANY fluid is injected into the skin, it must be surgically removed within a few hours by a doctor familiar with this type of injury or gangrene may result.
- Use a piece of cardboard or paper to search for leaks.



#### IMPORTANT

Keep hydraulic coupler tips and connectors clean. Dust, dirt, water and foreign material are the major causes of hydraulic system damage.

DO NOT attempt to service hydraulic system in the field. Precision fits require WHITE ROOM CARE during overhaul.

## SECTION 10. MAINTENANCE AND SERVICING

### 10.6.4 HYDRAULIC SCHEMATICS

Refer to the appropriate schematic that suits your machine.

#### 10.6.4.1 Double Reel

D60 Harvest Header and FD70 FlexDraper

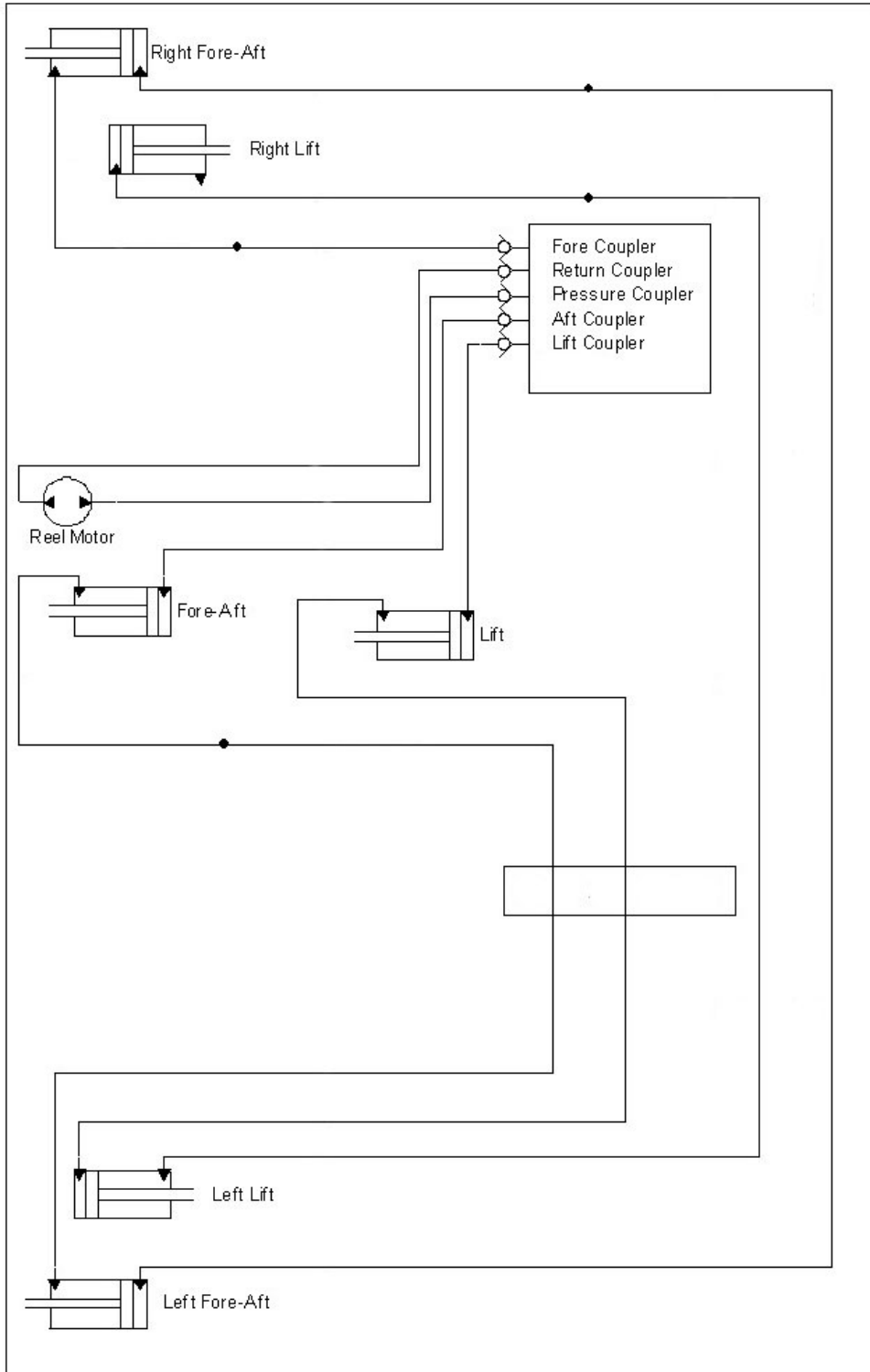



**SECTION 10. MAINTENANCE AND SERVICING**

**10.6.4.2 Single Reel**

D50 and D60 Harvest Header

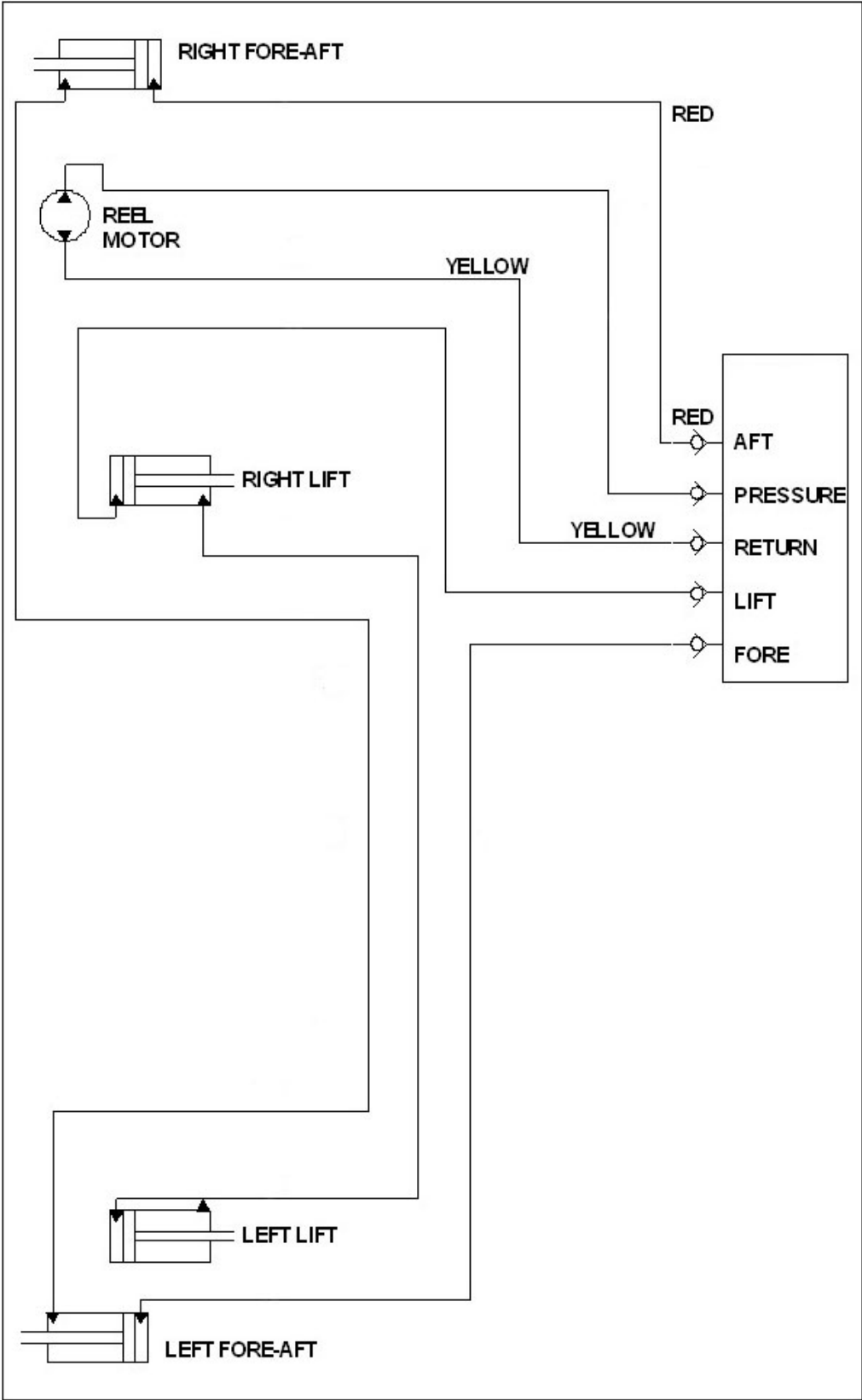

# SECTION 10. MAINTENANCE AND SERVICING

## 10.6.4.3 Combine Adapter

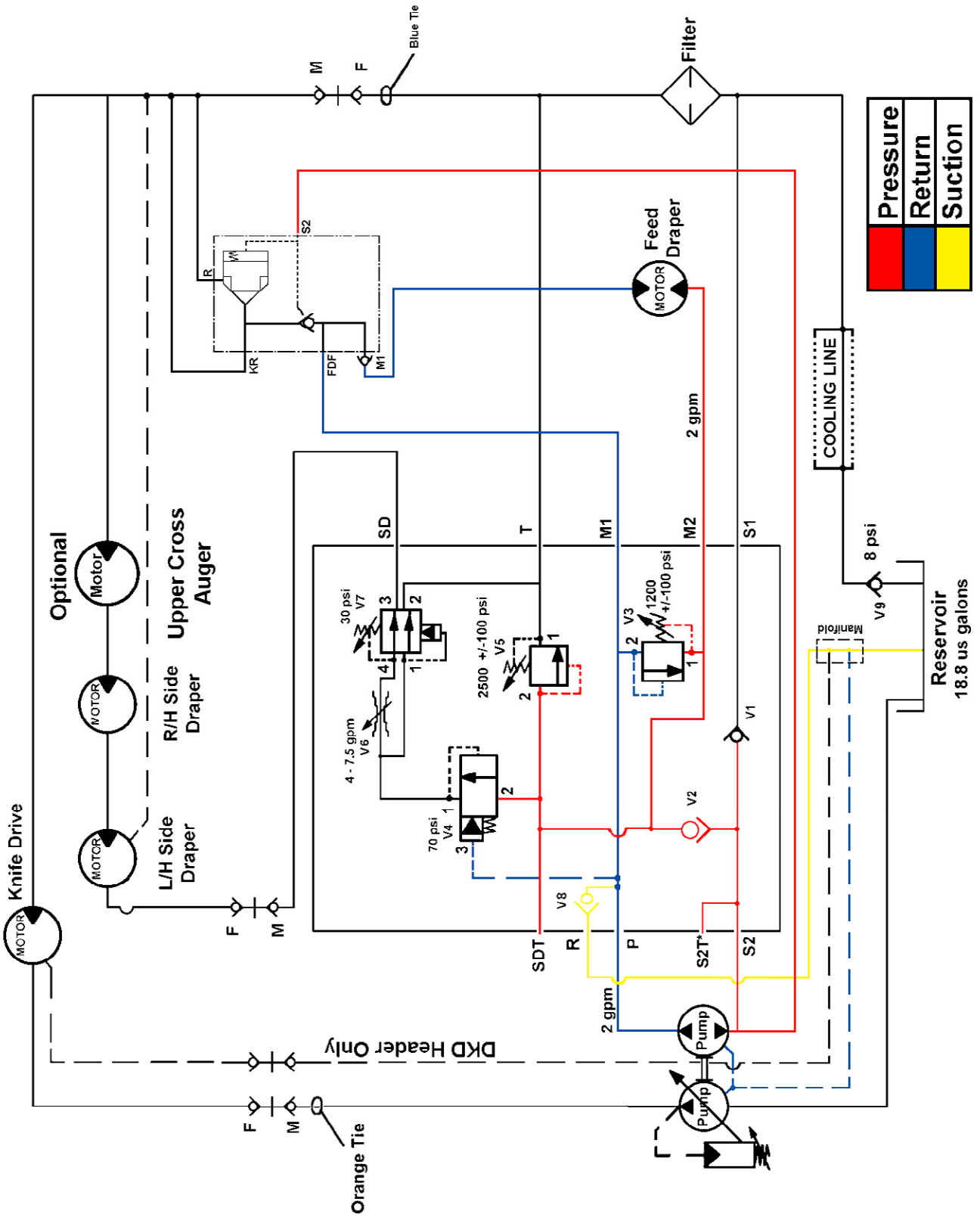

Pressure
Return
Suction

## SECTION 10. MAINTENANCE AND SERVICING

### 10.7 ELECTRICAL

- Use electrical tape and wire clips as required to prevent wires from dragging or rubbing.
- Keep lights clean and replace defective bulbs.



- To replace light bulbs:
  - Using a Phillips screwdriver, remove screws from fixture and remove plastic lens.
  - Replace bulb and reinstall plastic lens and screws.

#### NOTE

*Bulb Part Number - Trade #1156.*

### 10.8 MAIN DRIVE

#### 10.8.1 DRIVELINE REMOVAL

The main driveline normally remains attached to the adapter and stored on the hook provided when not in use.



#### CAUTION

**Stop engine and remove key from ignition before leaving Operator's seat for any reason. A child or even a pet could engage an idling machine.**

- If adapter is attached to the combine, remove the driveline from the combine by pulling quick disconnect collar to release driveline yoke at combine shaft.

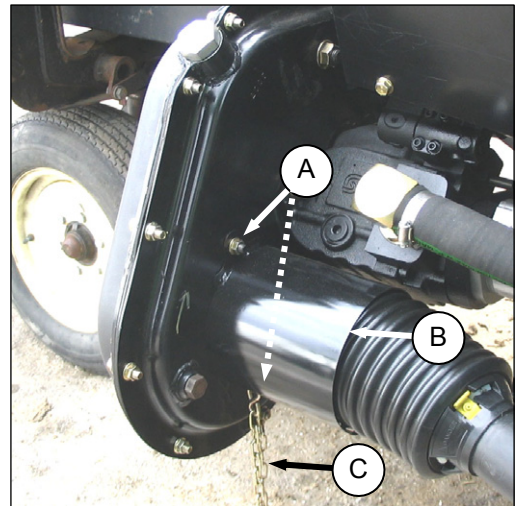

- Remove two nuts (A) attaching shield (B) to gearbox.
- Slide shield over poly driveline shield to expose quick disconnect on gearbox. Do not disconnect tether (C).
- Pull quick disconnect collar to release driveline yoke and pull driveline off shaft.
- Slide shield (B) off the driveline.

- Rotate disc (D) on adapter driveline storage hook (E) and remove driveline from hook.

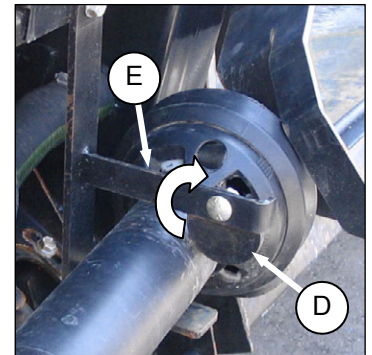



## SECTION 10. MAINTENANCE AND SERVICING

### 10.8.2 DRIVELINE INSTALLATION

#### IMPORTANT

If combine output shaft splines match adapter input shaft splines, ensure driveline is installed with longer guard at adapter gearbox end.



#### CAUTION

Stop engine and remove key from ignition before leaving Operator's seat for any reason. A child or even a pet could engage an idling machine.

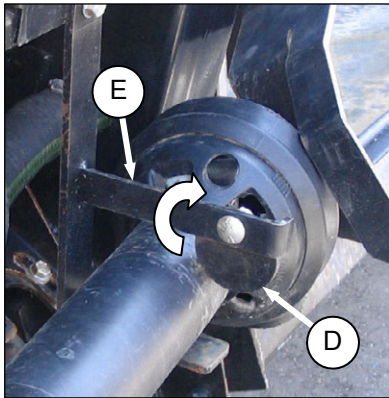

- Slide driveshaft in hook (E) so that disc (D) drops to secure driveshaft.

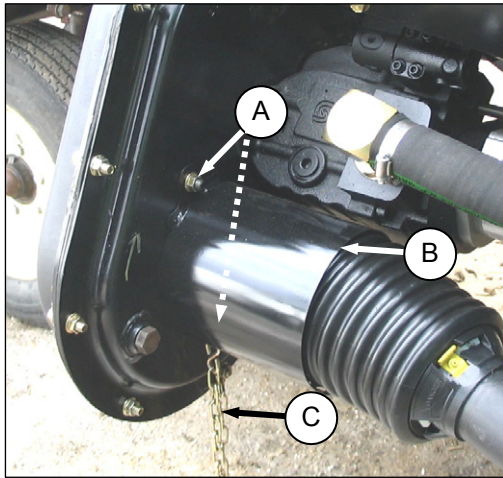

- Slide shield (B) over driveline.
- Locate driveline quick disconnect onto adapter gearbox shaft, pull back collar and slide onto shaft until yoke locks onto shaft. Release the collar.
- Position shield (B) on gearbox and secure with nuts (A).
- Reconnect other end to combine if necessary.

### 10.8.3 GUARD REMOVAL

The main driveline guard normally remains attached to the driveline.

If removal is required for maintenance, proceed as follows:



#### CAUTION

Stop engine and remove key from ignition before leaving Operator's seat for any reason. A child or even a pet could engage an idling machine.

#### NOTE

The driveline does not need to be removed from the adapter in order to remove the driveline guard.

- Rotate disc (D) on adapter driveline storage hook (E) and remove driveline from hook.



- Lift combine end of driveline (F) from hook and extend driveline until it separates. Hold adapter end of driveline to prevent it from dropping and hitting the ground.

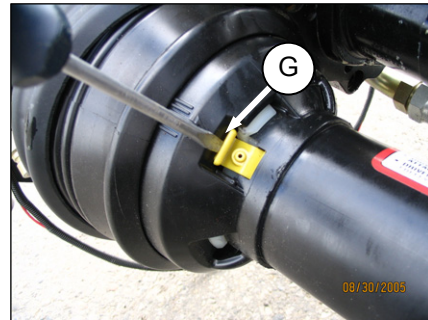

- Release grease zerkl/lock (G) with a screwdriver.  
*(continued next page)*

## SECTION 10. MAINTENANCE AND SERVICING

### 10.8.4 GUARD INSTALLATION

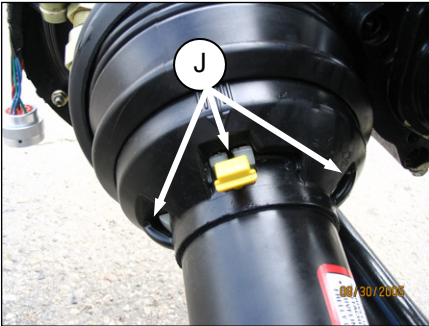
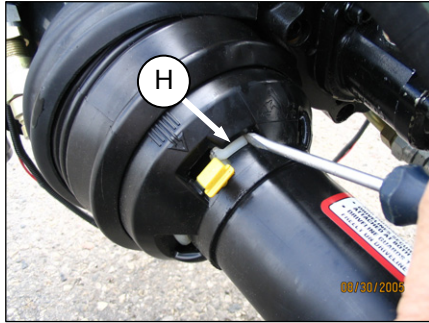

- d. Rotate guard locking ring (H) counter clockwise with a screwdriver until lugs (J) line up with slots in guard.
- e. Pull guard off driveline.
- f. Repeat above steps c. to e. for other driveline guard.

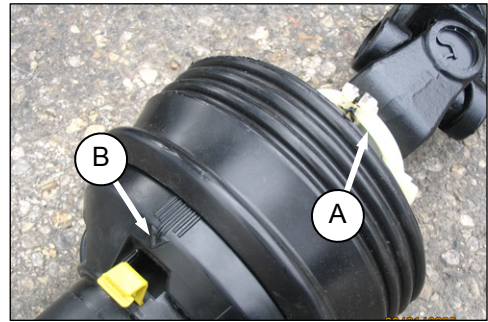

- a. Slide guard onto driveline and line up slotted lug on locking ring (A) with arrow (B) on guard.

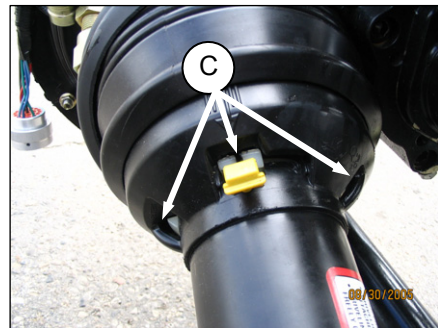

- b. Push guard onto ring until locking ring is visible in slots (C).

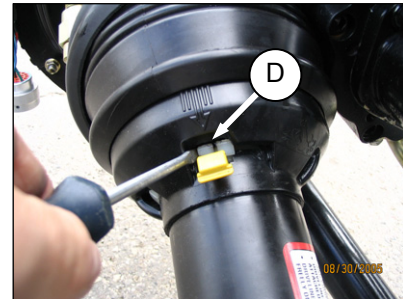

- c. Rotate ring (D) clockwise with a screwdriver to lock ring in guard.



- d. Push grease zerk (E) back into guard.
- e. Repeat steps a. to d. for other guard.

*(continued next page)*



## SECTION 10. MAINTENANCE AND SERVICING

- f. Reassemble driveline.

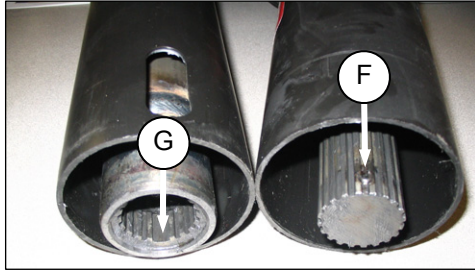

### NOTE

The splines are keyed so that universals are aligned. Align weld (F) with missing spline (G) when assembling.

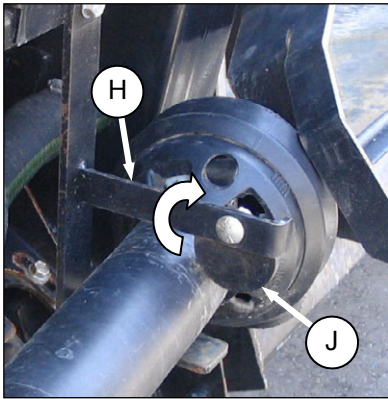

- g. Slide driveshaft in hook (H) so that disc (J) drops to secure driveshaft or connect to combine.

### 10.8.5 DRIVE CHAIN ADJUSTMENT

A sprocket on the main drive input shaft from the combine drives another shaft to the auger.

To adjust tension on the chain in the main gearbox, refer to illustration and proceed as follows:



### CAUTION

Stop engine and remove key from ignition before leaving Operator's seat for any reason. A child or even a pet could engage an idling machine.

- a. Lower header, stop engine and remove key.

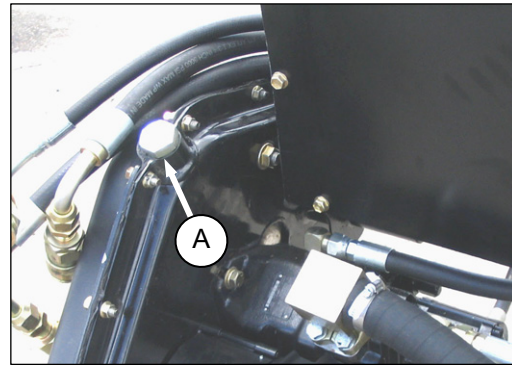

- b. Remove filler plug (A).

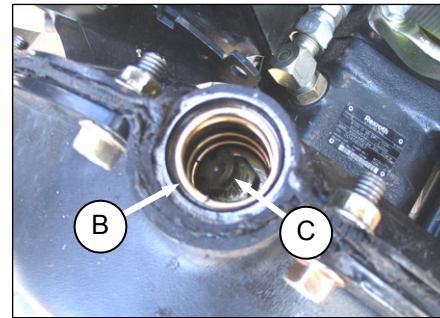

- c. Remove spring (B) and keeper (C) inside filler port.  
d. Using a  $\frac{3}{4}$  inch (19 mm) socket, torque bolt inside filler hole to 20 in·lbf, then back off bolt  $1\frac{1}{4}$  turns.  
e. Replace keeper (C), spring (B), and filler plug (A).



## SECTION 10. MAINTENANCE AND SERVICING

### 10.9 AUGER

#### 10.9.1 AUGER PAN CLEARANCE

Adapters are factory set to the proper auger clearances to the pan and feed draper. See illustration.

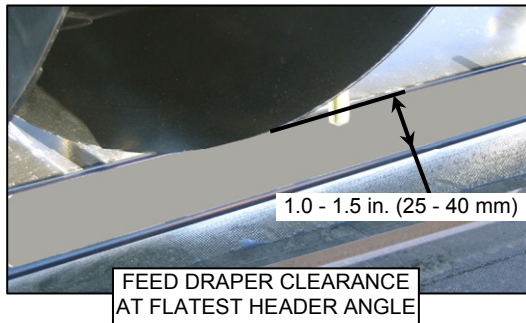
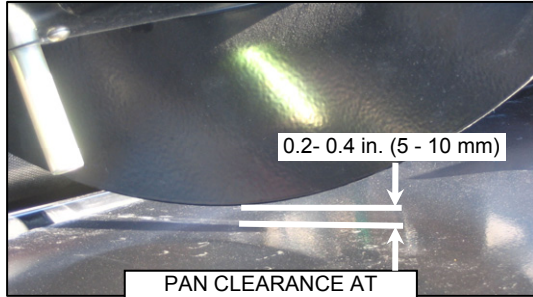

It is important that these clearances are maintained. Too little clearance may result in the tines or flighting contacting and damaging the draper or feed pan under certain orientations of the header. Look for evidence of contact when greasing the adapter.

Should adjustment to the auger be necessary, proceed as follows:

- a. Extend center-link to maximum for steepest header angle and fully lower the header.

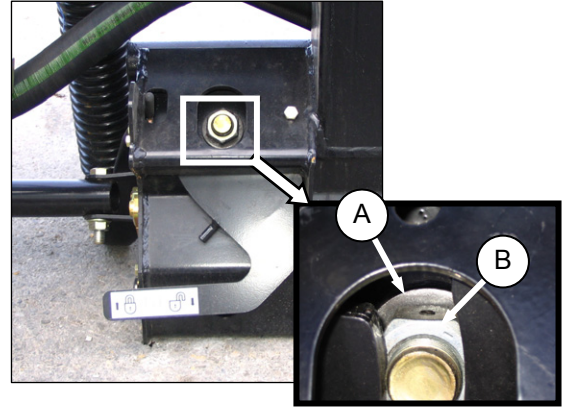

- b. Check that adapter float linkage is on downstops (washer (A) and nut (B) cannot be moved).

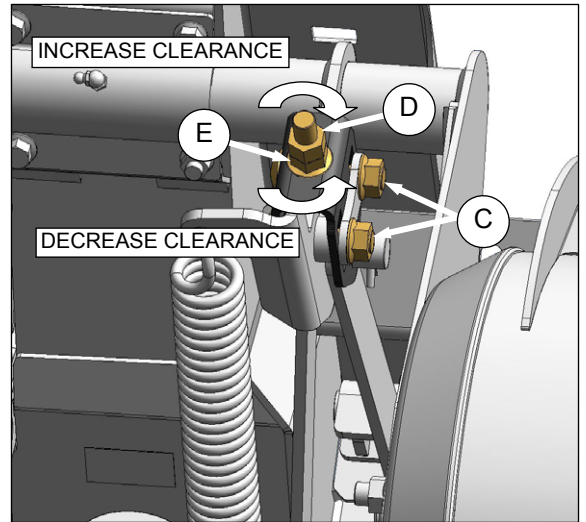

- c. Loosen two nuts (C) and jam-nut (D).
- d. Turn nut (E) clockwise to raise auger and increase pan/draper clearance.
- e. Repeat for other end of auger.
- f. Check clearances and re-adjust as required.
- g. Tighten nuts (C) and jam-nut (D) on both ends of auger.

## SECTION 10. MAINTENANCE AND SERVICING

### 10.9.2 AUGER DRIVE CHAIN ADJUSTMENT

The auger is driven from the adapter drive system by a sprocket that is attached to the side of the auger. To adjust the chain tension, refer to illustration below and proceed as follows:



#### CAUTION

Stop engine and remove key from ignition before leaving Operator's seat for any reason. A child or even a pet could engage an idling machine.

- a. Detach combine from adapter. Refer to Section 7 HEADER ATTACHMENT/DETACHMENT.

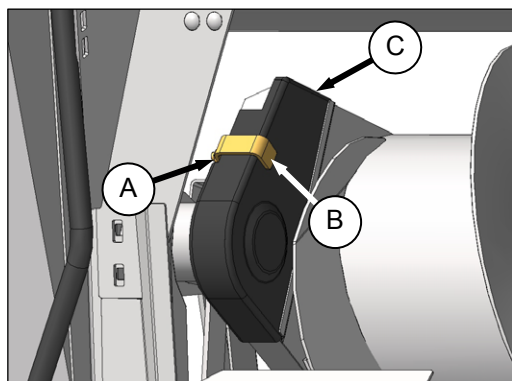

- b. Loosen nut (A) and remove clip (B) and cover (C).

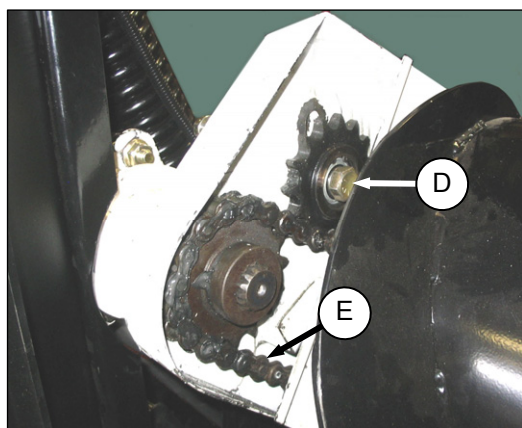

- c. Loosen bolt (D) on idler sprocket.
- d. Rotate auger in reverse to take up slack in lower strand of chain (E).
- e. Push idler sprocket down to eliminate remaining slack in upper strands.
- f. Rotate auger back and forth to check slack and repeat above step if necessary. A slight amount of slack is acceptable.

#### NOTE

Do not use excessive force on idler to tighten chain.

- g. Tighten idler bolt (D) and torque to 150 in·lbf (203 N·m).

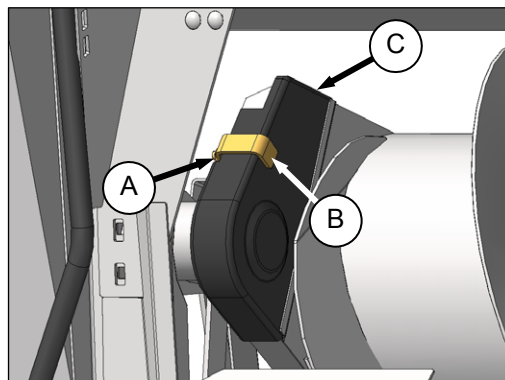

- h. Reinstall cover (C) with clip (B) and tighten nut (A).

### 10.9.3 AUGER DRIVE CHAIN REPLACEMENT

The chain tensioner can only take up slack for a single pitch.

When the chain has worn or stretched beyond the limits of the tensioner, the chain should be replaced, or removed to replace the connector link with an offset half link.



#### CAUTION

Stop engine and remove key from ignition before leaving Operator's seat for any reason. A child or even a pet could engage an idling machine.

- a. Detach header from combine. Refer to Section 7 HEADER ATTACHMENT/DETACHMENT.

*(continued next page)*

## SECTION 10. MAINTENANCE AND SERVICING

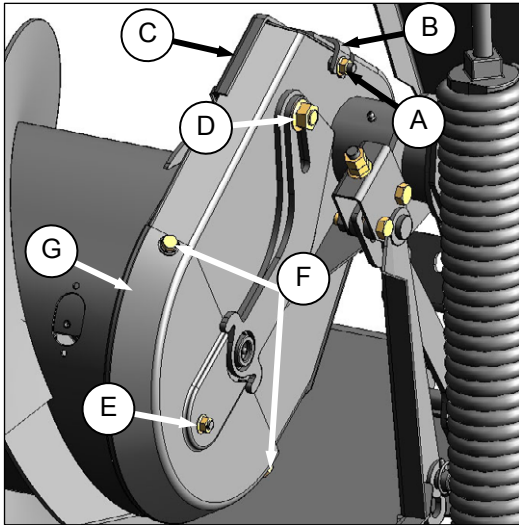

- b. Loosen nut (A) and remove clip (B) and cover (C).
- c. Remove chain as follows:
  1. Loosen idler sprocket bolt (D) and raise to uppermost position to release tension on chain. Snug up bolt (D) to hold sprocket.
  2. Remove nut (E) and bolts (F) and remove cover (G).

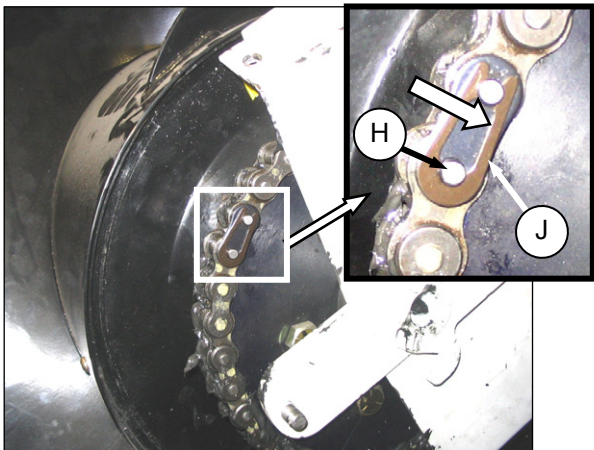

3. Rotate auger to expose connector link (H).
4. Push on one leg of clip (J) to remove it from link.
5. Remove link and remove chain.
6. Replace one link with an offset link and reinstall, or install a new chain.

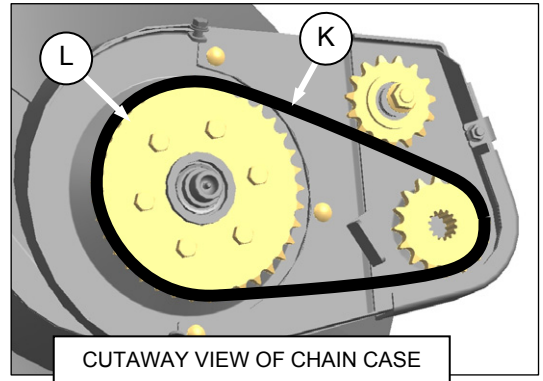

- d. Install chain as follows:
  1. Feed chain (K) around sprockets as shown and position so that connection can be made on driven sprocket (L).
  2. Install connector link (H). Refer to Section 10.3.2 Roller Chain Installation.
- e. Tighten chain. Refer to Section 10.9.2 Auger Drive Chain Adjustment.
- f. Lubricate the chain with SAE Multi-Purpose High Temp. Extreme Pressure (EP2) Performance With 1% Max Molybdenum Disulphide (NLGI Grade 2).

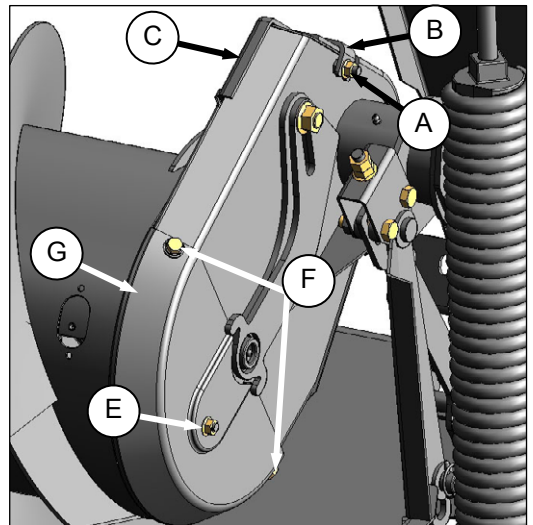

- g. Position cover (G) on case and secure with nut (E) and bolts (F).
- h. Position cover (C) on case and secure with clip (B). Tighten nut (A).



## SECTION 10. MAINTENANCE AND SERVICING

### 10.9.4 AUGER TINE REPLACEMENT

The CA20 Combine Adapters are fitted with tines to accommodate a wide variety and sizes of combines. Some conditions may require the removal or addition of tines for optimal feeding of the crop. In addition, tines that become worn or damaged should be replaced.

To simplify the procedure, detach header from combine.

Refer to Section 7 HEADER ATTACHMENT/DETACHMENT.

#### 10.9.4.1 Tine Removal

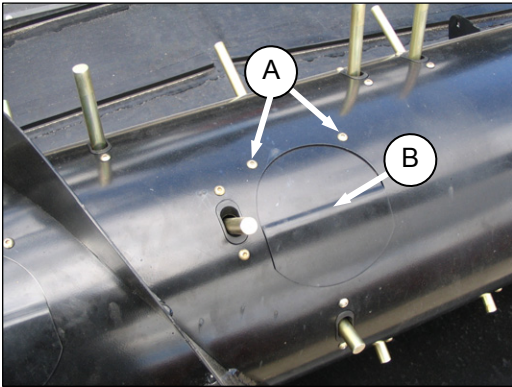

- a. Remove screws (A) and remove access cover (B).

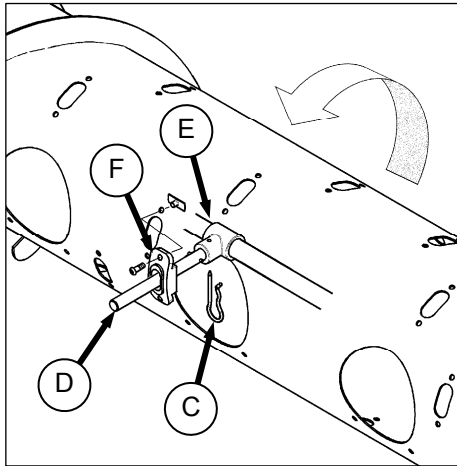

- b. From inside the auger, remove hairpin (C) and pull tine (D) out of bushing (E).
- c. From inside the auger, swivel tine away from bushing, pull from plastic guide (F) and remove from auger.

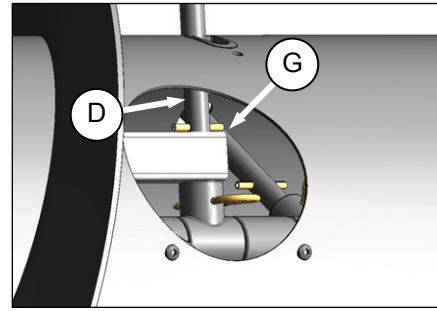

#### NOTE

*If the sixth tine (D) opposite drive side is being replaced, it also must be slipped off drive tube (G). This particular tine cannot be removed for normal operation.*

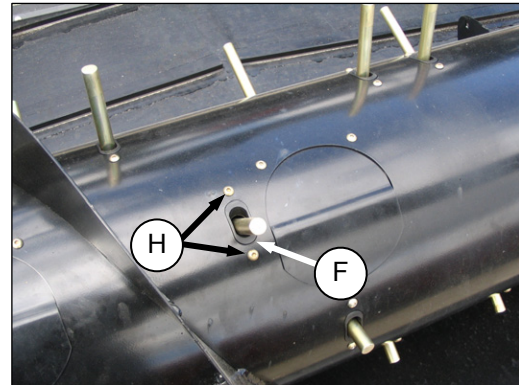

- d. Remove screws (H) securing plastic guide (F) to auger and remove guide from inside auger.

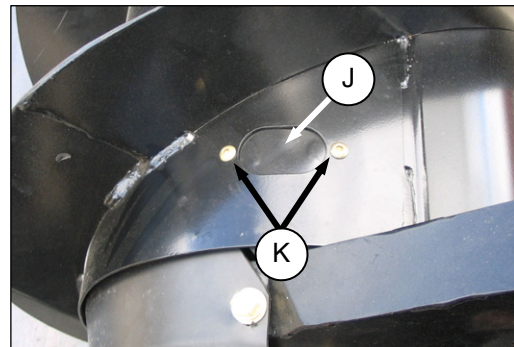

- e. Position cover (J) from inside auger over hole and secure with screws (K). Coat screws with Loctite® #243 (or equivalent) and torque to 75 in·lbf (8.5 N·m).

## SECTION 10. MAINTENANCE AND SERVICING

### 10.9.4.2 Tine Installation

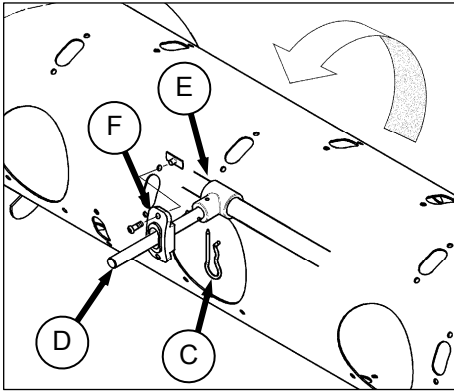

- a. Insert tine (D) through plastic guide (F) from inside the auger.

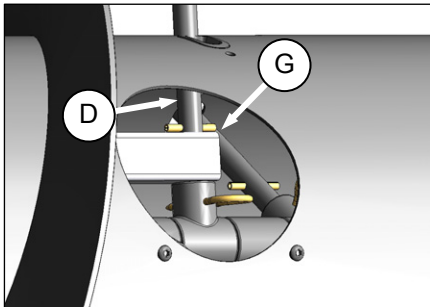

- b. Insert tine into bushing (E).

**NOTE**

*The #6 tine (D) must also be inserted through the square tube (G).*

- c. Secure tine in bushing with hairpin (C). Install hairpin with closed end leading with respect to auger forward rotation.

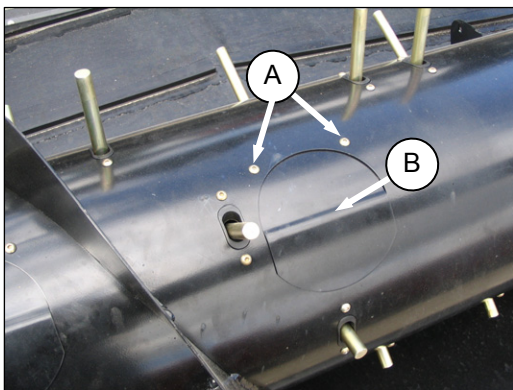

- d. Replace access cover (B) and secure with screws (A). Coat screws with Loctite® #243 (or equivalent) and torque to 75 in·lbf (8.5 N·m).

## SECTION 10. MAINTENANCE AND SERVICING

### 10.10 VIBRATION DAMPERS

Worn or damaged vibration dampers will cause excessive noise and vibration, and it is recommended they be replaced.

The header and adapter must be detached to replace the dampers. Refer to Section 8 HEADER/ADAPTER DISASSEMBLY AND ASSEMBLY.

#### 10.10.1 RUBBER PAD REPLACEMENT

##### Secondary Vibration Damper (D50 and D60 Harvest Header only):

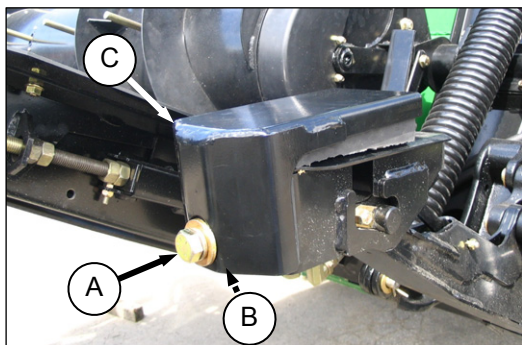

- Remove bolt (A), washer and spacer (B) and remove secondary vibration damper (C) from adapter arm.
- Remove rubber pad (D) from shoe.
- Place new pad (D) in shoe, and position damper (C) on primary damper.
- Secure with bolt (A), spacer (B) and washer.

##### Primary Vibration Damper (D50 and D60 Harvest Header and FD70 FlexDraper):

- Remove secondary damper (if applicable). See above.

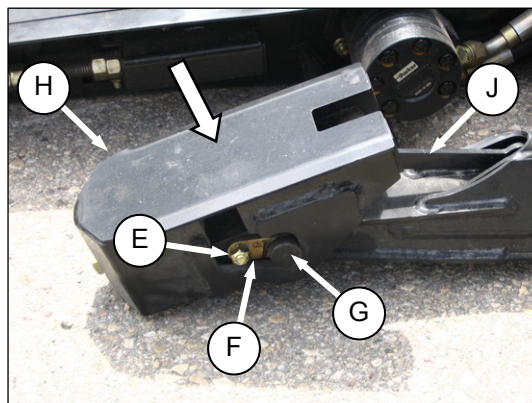

- Remove nut (E) and keeper (F) from primary damper.
- Slightly compress damper as shown and remove pin (G). Remove top half (H). Link (J) will hold bottom half of damper.

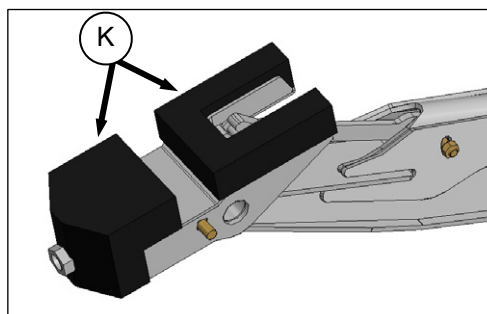

- Remove worn or damaged rubber pads (K).
- Position new rubber pads (K) in lower half and position upper half (H). Ensure link (J) is engaged in damper.
- Slightly compress the two halves so that pin (G) can be installed.
- Attach keeper (F) and secure with nut (E).
- Re-attach secondary damper (if applicable). See opposite.



## SECTION 10. MAINTENANCE AND SERVICING

### 10.11 SICKLE AND SICKLE DRIVE



#### CAUTION

To avoid personal injury, before servicing machine or opening drive covers, follow procedures in Section 10.1 PREPARATION FOR SERVICING.



#### WARNING

Keep hands clear of the area between guards and sickle at all times.

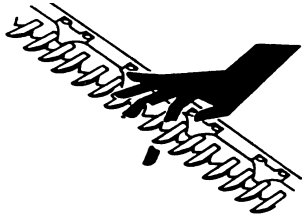

#### CAUTION

Wear heavy gloves when working around or handling sickles.

#### 10.11.1 SICKLE SECTIONS

Check daily that sections are firmly bolted to the sickle back and are not worn or broken. Damaged or worn sections leave behind uncut plants.

Coarse serrated sections last longer than fine serrated sections in dirty or sandy conditions.

Fine serrated sections perform better in fine stemmed grasses and plants that contain more fibrous stems.

A worn or broken sickle section can be replaced without removing sickle from cutterbar.

Replace sickle section as follows:

#### NOTE

Stroke sickle as required to expose sickle.

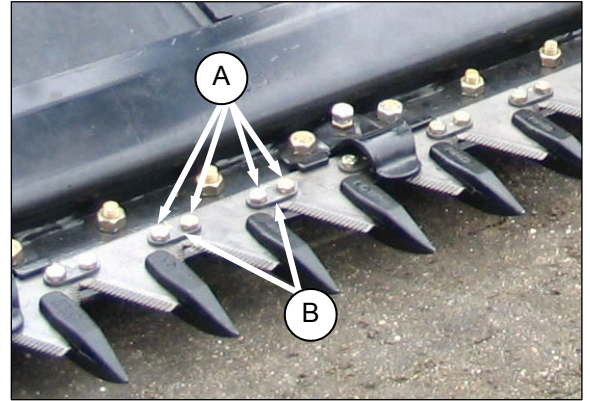

- Remove locknuts (A).
- Remove bars (B) and lift sickle section off knife.

#### IMPORTANT

Do not mix heavy and light sickle sections on same sickle.

- Clean any dirt off of sickle back and position new sickle section on knife.
- Reposition bars (B) and install locknuts (A).
- Torque nuts to 7 ft·lbf (9.5 N·m).

## SECTION 10. MAINTENANCE AND SERVICING

### 10.11.2 SICKLE REMOVAL



#### WARNING

Stand to rear of sickle during removal to reduce risk of injury from cutting edges. Wear heavy gloves when handling sickle.

- Stroke sickle to its outer limit and clean area around sickle head.

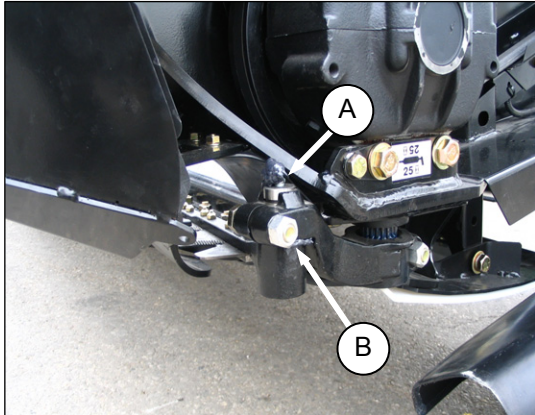

- Remove zerk from pin (A).
- Remove nut and bolt (B).
- Insert screwdriver in groove of pin (A) and pry up on sickle head pin to free sickle. Pin does not have to be removed from arm.
- Seal bearing in sickle head with plastic or tape.
- Wrap a chain around sickle head and pull sickle out.

#### NOTE

For single drive sickles with splice plate, remove bolts from splice plate and pull sickle out from both ends.

### 10.11.3 SICKLE HEAD BEARING REPLACEMENT

#### 10.11.3.1 Bearing Removal

- Remove sickle. Refer to previous section.
- Using a flat-ended tool (D) with approximately the same diameter as the plug (E), tap out the seal (F), bearing (G), and plug from the underside of the head.

#### NOTE

The seal can be replaced without removing the bearing. When changing seal, check pin and needle bearing for wear. Replace if necessary.

#### 10.11.3.2 Bearing Installation

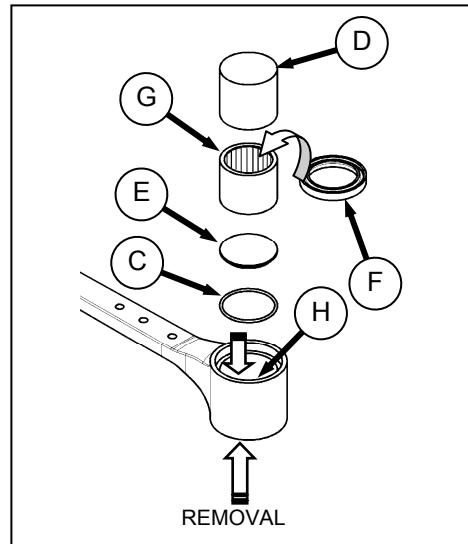

- Place O-ring (C) and plug (E) in sickle head.

#### IMPORTANT

Install the bearing with the stamped end (the end with identification markings) against the tool.

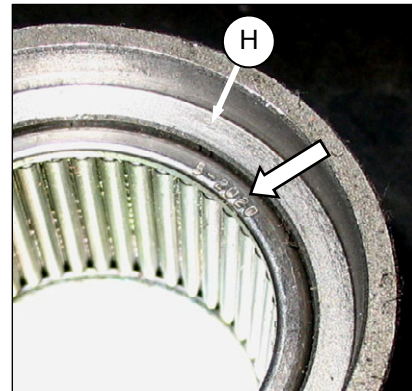

- Using a flat-ended tool (D) with approximately the same diameter as the bearing (G), push the bearing into the sickle head until the top of the bearing is flush with the step (H) in sickle head.
- Install seal (F) in top of sickle head with lip facing outwards.

#### IMPORTANT

To avoid premature sickle head or wobble box failure, be sure there is no looseness in:

- fit of sickle head pin and needle bearing, and
- fit of sickle head pin and pitman arm.

## SECTION 10. MAINTENANCE AND SERVICING

### 10.11.4 SICKLE INSTALLATION



#### WARNING

Stand to rear of sickle during installation to reduce risk of injury from cutting edges. Wear heavy gloves when handling sickle.

#### IMPORTANT

Align guards and re-set sickle hold-downs while replacing sickle.

If sickle head pin (A) is installed in the sickle head, remove the pin.

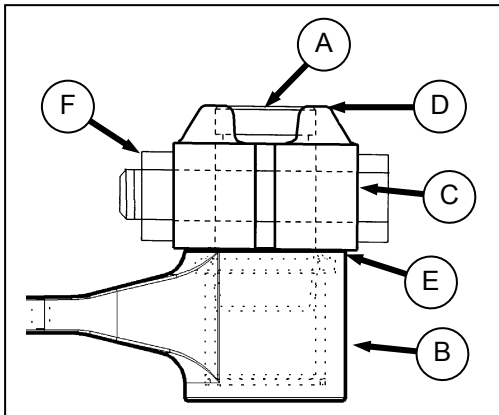

- Slide sickle into place and align sickle head (B) with pitman arm (C).
- Install sickle head pin (A) in pitman arm and tap it down into the sickle head, ensuring pin is bottomed out in the sickle head.
- Tap the underside of the sickle head (B) until the pin is flush with the upper face (D) of the pitman arm and until it just contacts pitman arm [0.010 in. (0.25 mm)] gap (E).
- Reinstall bolt and nut (F).
- Tighten nut to 160 ft·lbf (220 N·m).
- Reinstall grease zerk in pin.
- Grease bearing.

### 10.11.5 SPARE SICKLE (SINGLE KNIFE HEADERS)

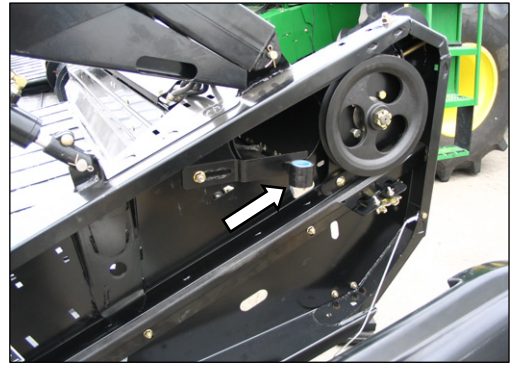

A spare sickle may be stored in the header frame tube at the left end as shown above. Ensure sickle is secured in place.



## SECTION 10. MAINTENANCE AND SERVICING

### 10.11.6 SICKLE GUARDS

Check daily that guards are aligned to obtain proper shear cut between sickle section and guard. Sickle sections should contact shear surface of each guard.

#### 10.11.6.1 Guard Adjustment

To align guards, refer to illustrations and proceed as follows. The guard straightening tool (MacDon #140135) is available from your MacDon Dealer.



UPWARD ADJUSTMENT

- a. To adjust guard tips upward, position tool as shown and pull up.



DOWNWARD ADJUSTMENT

- b. To adjust tips downward, position tool as shown and push down.

**TIP:** If trouble is encountered cutting tangled, or fine-stemmed material, replace lower guards with stub guards and install a sickle hold-down on every guard. If material is tough to cut, install stub guards with top guard and adjuster plate. A stub guard conversion kit is available from your MacDon Dealer. Refer to Section 12.7 STUB GUARD CONVERSION KIT.

#### 10.11.6.2 Guard Replacement



### CAUTION

Always engage reel props before working under reel.

##### 10.11.6.2.1 Pointed Guards - Single Knife

To replace pointed guards in single knife D50 and D60 Harvest Headers and FD70 FlexDraper headers, refer to illustrations and proceed as follows:

- a. Stroke the sickle so that the sickle sections are spaced midway between the guards.

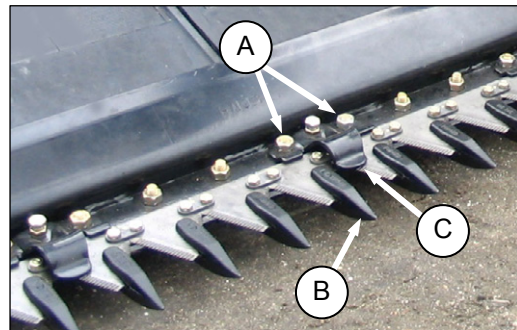

- b. Remove the two nuts (A) and bolts that attach guard (B) and hold-down (C) (if applicable) to the cutterbar.
- c. Remove the guard, hold-down, and poly wear plate (if installed).
- d. Position new guard and poly wear plate (if applicable) on cutterbar and install carriage bolts.

#### IMPORTANT

The first four outboard guards on drive side(s) of the header do not have a ledger plate. Ensure that the proper replacement is installed.

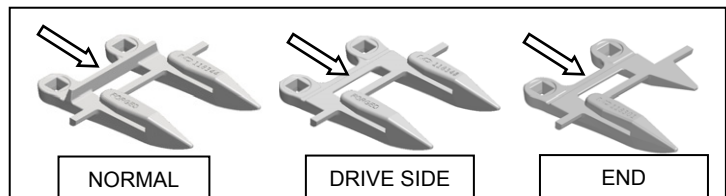

- e. Install hold-down and secure with nuts. Tighten nuts to 50 ft·lbf (68 N·m).
- f. Check and adjust clearance between hold-down and sickle. Refer to Section 10.11.7 Sickle Hold-Downs.

## SECTION 10. MAINTENANCE AND SERVICING

### 10.11.6.2.2 Pointed Guards - Double Knife

Refer to previous section for typical guard replacement.

The guard near the center of the double knife header, where the two sickles overlap, requires a slightly different replacement procedure. Replace the center guard or center top guide as follows:

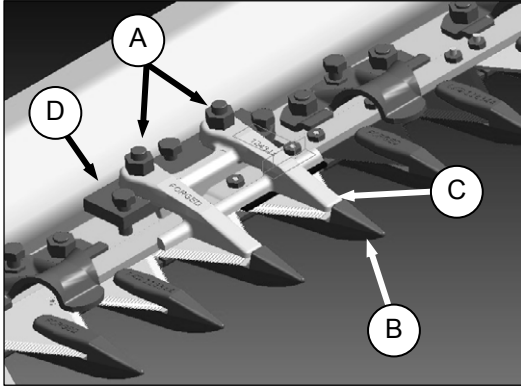

- Remove the two nuts (A) and bolts that attach guard (B) and top guide (C) to cutterbar.
- Remove guard, poly wear plate (if installed), top guide (C), and adjuster bar (D).
- Position poly wear plate (if applicable), replacement guard (B), adjuster bar (D), top guide (C), and install bolts but do not tighten.

#### IMPORTANT

Ensure center guard (B) (right of cutterbar split) has offset cutting surfaces. See illustrations.

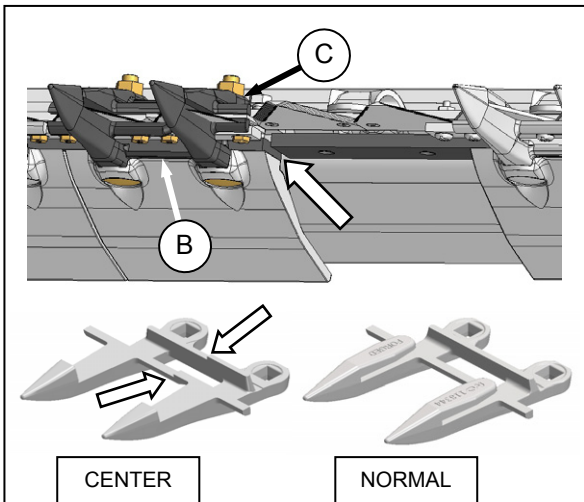

#### NOTE

*Top guide (C) must accommodate the two overlapping knives at center guard location on double-knife header. Ensure replacement is correct part.*

- Check and adjust clearance between hold-down and sickle. Refer to Section 10.11.7 Sickle Hold-Downs.

### 10.11.6.2.3 Stub Guards - Single Knife

Stub guards, complete with top guides and adjuster plates are designed to cut tough crops. Only the D60 Harvest Header 20 ft. and 25 ft. models can be equipped with stub guards.

Replace stub guards as follows:

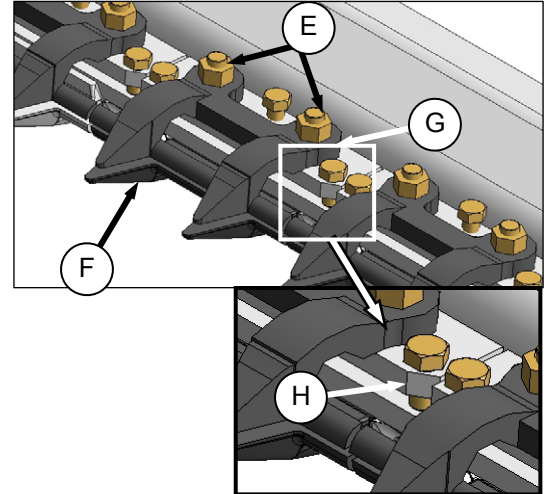

- Remove the two nuts (E) and bolts that attach guard (F) and top guide (G) to cutterbar.
- Remove guard, poly wear plate (if installed), top guide, and adjuster bar (H).
- Position poly wear plate (if applicable), replacement guard (F), adjuster bar (H), top guide (G), and install bolts. Do not tighten.

#### IMPORTANT

Note position of mitre on adjuster bar (H). Bar should be reinstalled in same position. Mitres should not be adjacent to each other.

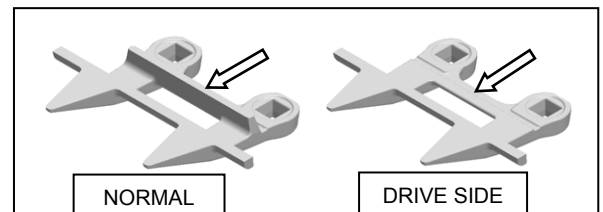

#### IMPORTANT

The first four outboard guards on drive side(s) of the header do not have a ledger plate. Ensure that the proper replacement is installed.

- Check and adjust clearance between top guide and sickle. Refer to Section 10.11.7 Sickle Hold-Downs.

## SECTION 10. MAINTENANCE AND SERVICING

### 10.11.6.2.4 Stub Guards - Double Knife

Refer to previous section for typical guard replacement.

The guard at the center of the double knife header, where the two sickles overlap, requires a slightly different replacement procedure.

To replace the center guard or center top guide, refer to illustration and proceed as follows:

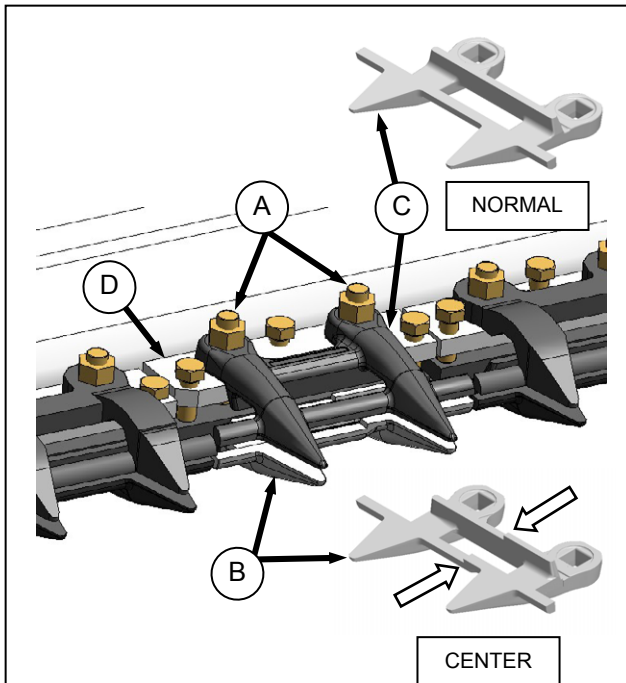

- Remove the two nuts (A) and bolts that attach guard (B) and top guide (C) and adjuster bar (D) to cutterbar.
- Remove guard, poly wear plate (if installed), top guide (C), and adjuster bar (D).
- Position poly wear plate (if applicable), replacement guard (B), adjuster bar (D), top guide (C), and install bolts but do not tighten.

#### IMPORTANT

Ensure center guard (B) (right of cutterbar split) has offset cutting surfaces. See illustration.

#### NOTE

*Top guide (C), which is an inverted normal stub guard, must accommodate the two overlapping knives at center guard location on double-knife header. Ensure replacement is correct part.*

- Check and adjust clearance between hold-down and sickle. Refer to Section 10.11.7 Sickle Hold-Downs.



## SECTION 10. MAINTENANCE AND SERVICING

### 10.11.7 SICKLE HOLD-DOWNS

Check daily that sickle hold-downs are set to prevent sickle sections from lifting off guards but still permit sickle to slide without binding.

#### NOTE

*Guards should be aligned prior to adjusting hold-downs.*

#### 10.11.7.1 Pointed Guard Adjustment

- a. To adjust the clearance between the hold-down and sickle for typical pointed guards:

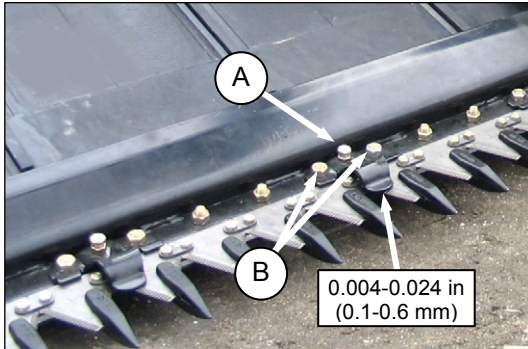

1. Turn the adjuster bolts (A). Using a feeler gauge, clearance from hold-down to sickle section should be 0.004 - 0.024 in. (0.1 - 0.6 mm).

#### NOTE

*For larger adjustments, it may be necessary to loosen nuts (B), turn adjuster bolt (A), then retighten nuts (B).*

- b. To adjust clearance between hold-down and sickle:

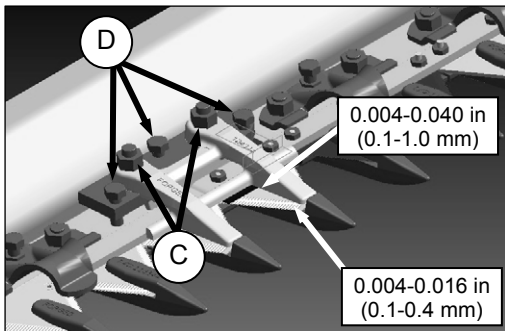

1. Torque nuts (C) to 35 ft·lbf (46 N·m).
2. Turn the adjuster bolts (D). Using a feeler gauge, clearance from hold-down to sickle section should be 0.004 - 0.016 in. (0.1 - 0.4 mm) at the guide tip, and 0.004 - 0.040 in. (0.1 - 1.0 mm) at rear of guide.
3. Torque nuts (C) to 53 ft·lbf (72 N·m).

- c. After adjusting all hold-downs, run header at a low engine speed, and listen for noise due to insufficient clearance. Insufficient clearance will also result in overheating of the sickle and guards. Re-adjust as necessary.

#### 10.11.7.2 Stub Guard Adjustment

To adjust the clearance between the hold-down and sickle for all stub guards:

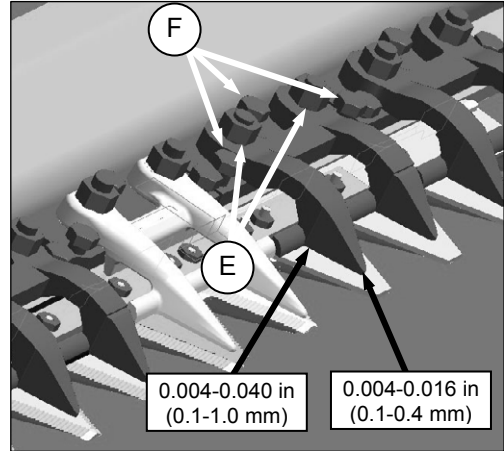

- a. Torque nuts (E) to 35 ft·lbf (46 N·m).
- b. Turn the adjuster bolts (F). Using a feeler gauge, clearance from hold-down to sickle section should be 0.004 - 0.016 in. (0.1 - 0.4 mm) at the guide tip, and 0.004 - 0.040 in. (0.1 - 1.0 mm) at rear of guide.
- c. Torque nuts (E) to 53 ft·lbf (72 N·m).

## SECTION 10. MAINTENANCE AND SERVICING

### 10.11.8 SICKLE DRIVE BELTS - NON TIMED DRIVE

This section applies to single knife headers, and 40 foot and 45 foot double knife headers with non-timed drives.

For double knife headers with timed drives, refer to Section 10.11.9 Double Knife Drive Belts - Timed Drive.

#### 10.11.8.1 Tension Adjustment

##### IMPORTANT

To prolong belt and drive life, do not over-tighten belt.



### CAUTION

To avoid personal injury, before servicing machine or opening drive covers, follow procedures in Section 10.1 PREPARATION FOR SERVICING.

- Open endshield.

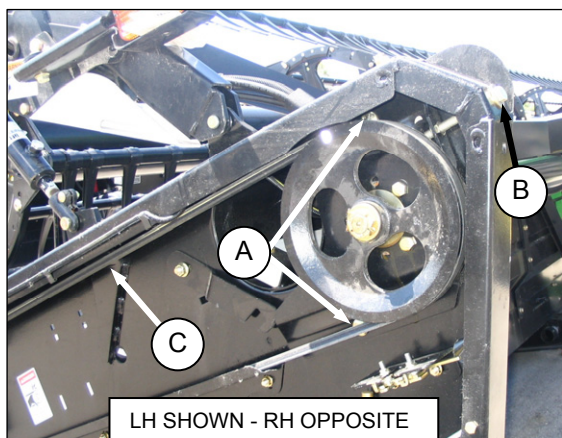

- Loosen two bolts (A) on sickle drive mounting bracket.
- Turn adjuster bolt (B) to move drive motor until a force of 20 lbf (80 N) deflects belt (C) 3/4 in. (18 mm) at mid-span.
- Tighten jam-nut at (B) and bolts (A) on drive mounting bracket.
- Re-adjust tension of a new belt after a short run-in period, (about 5 hours).

#### 10.11.8.2 Removal

- Loosen sickle drive belt using procedure in previous section so that belt (C) can be slipped off drive pulley.

- Remove bolt in plate (D) in endsheet at wobble box and remove the plate.

This provides clearance between the pulley and endsheet for the belt when it is removed.

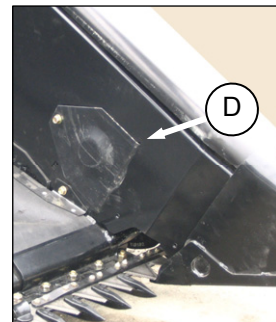

- Slip belt over and behind wobble box pulley (E) and remove belt. Utilize the notch in the pulley to assist in removing the belt.

#### 10.11.8.3 Installation

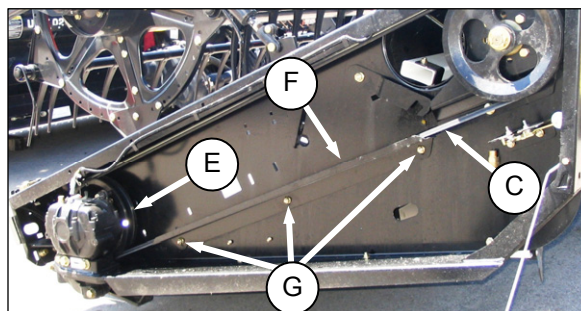

- Route sickle drive belt (C) around wobble box pulley (E) and sickle drive pulley. Utilize the notch in the pulley to assist in installing the belt.

##### NOTE

*When installing new belt, never pry belt over pulley. Be sure drive motor is fully forward, then tension belt.*

- Tighten belt. Refer to Section 10.11.8.1 Tension Adjustment in opposite column.
- Check clearance between belt (C) and belt guide (F). The measurement should be 0.04 in. (1 mm). Adjust as follows:
  - Ensure belt is properly tensioned.
  - Loosen bolts (G) and adjust position of guide (F) as required.
  - Tighten bolts.
- Reinstall plate (D) and secure with bolt and nut.
- Close endshield.



## SECTION 10. MAINTENANCE AND SERVICING

### 10.11.9 DOUBLE KNIFE DRIVE BELTS - TIMED DRIVE

This section applies to 35 foot and smaller double knife Model D60 Harvest Headers with timed drives.

For single knife headers and non-timed double knife headers, refer to Section 10.11.8 Sickle Drive Belts - Non-Timed Drive.

#### 10.11.9.1 Left End Drive

Remove endshield at left end of header. Refer to Section 10.4 ENDSHIELDS AND COVERS.



### CAUTION

To avoid personal injury, before servicing machine or opening drive covers, follow procedures in Section 10.1 PREPARATION FOR SERVICING.

#### 10.11.9.1.1 Tension Adjustment - Timing Belt

##### IMPORTANT

To prolong belt and drive life, do not over-tighten belt.

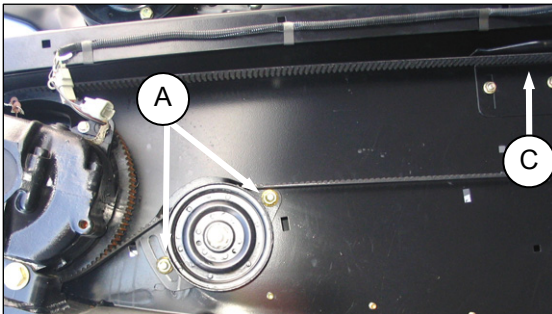

- Loosen two nuts (A) on sickle drive belt idler bracket.

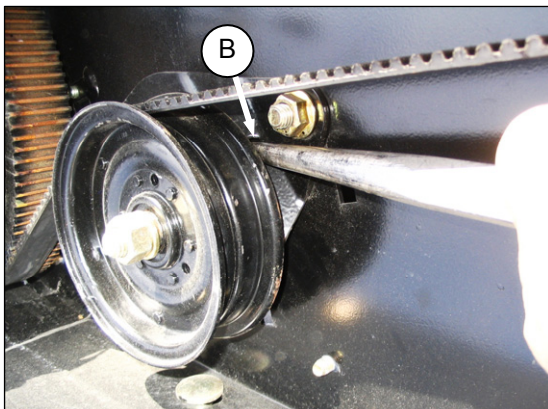

- Insert a long punch or equivalent into hole (B) in idler bracket, and pry downward until a force of 6 lbf (27 N) deflects timing belt 1/2 in. (13 mm) at mid-span (C).

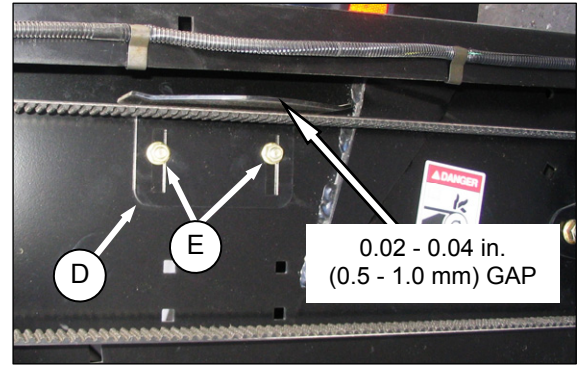

- Tighten nuts (A) on idler mounting bracket.
- Check clearance between belt and belt guide (D). The measurement should be 0.02 - 0.04 in. (0.5 - 1.0 mm). Adjust as follows:
  - Ensure belt is properly tensioned.
  - Loosen bolts (E) and adjust position of guide as required.
  - Tighten bolts.
- Re-adjust tension of a new belt after a short run-in period, (about 5 hours).

#### 10.11.9.1.2 Removal - Left End Timing Belt

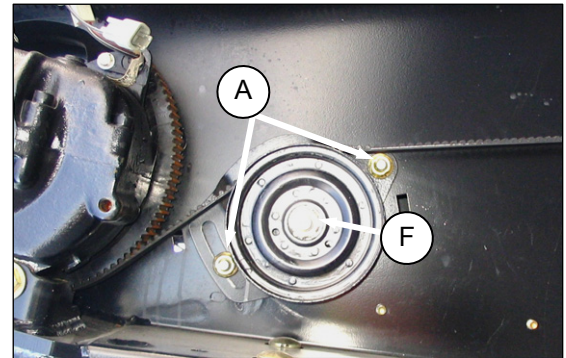

- Loosen two nuts (A) on belt idler bracket to relieve tension on belt.
- Loosen nut (F) on idler pulley and slide idler down to loosen belt.

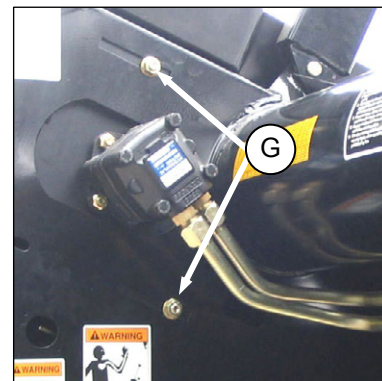

- Loosen two bolts (G) on endsheet.

(continued next page)



## SECTION 10. MAINTENANCE AND SERVICING

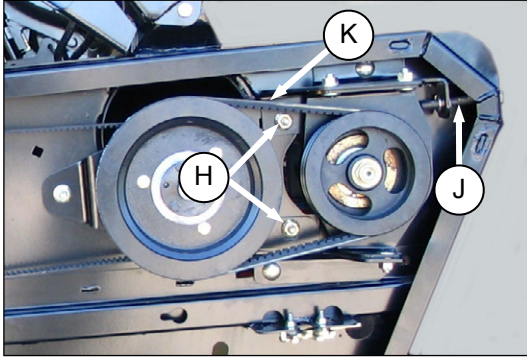

- d. Loosen two bolts (H) on sickle drive mounting bracket.
- e. Turn adjuster bolt (J) to loosen the two V-belts (K) and remove belts.

- f. Remove bolt in plate (L) in left endsheet at wobble box and remove the plate.

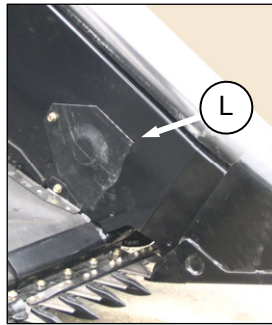

This provides clearance between the pulley and endsheet for the belt when it is removed.

- g. Slip timing belt off wobble box pulley and route the belt between the wobble box pulley and the endsheet.
- h. Remove belt from drive pulley.

### 10.11.9.1.3 Installation - Left End Timing Belt

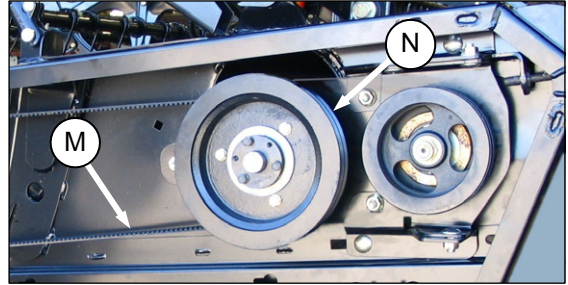

- a. Locate timing belt (M) onto drive pulley (N).

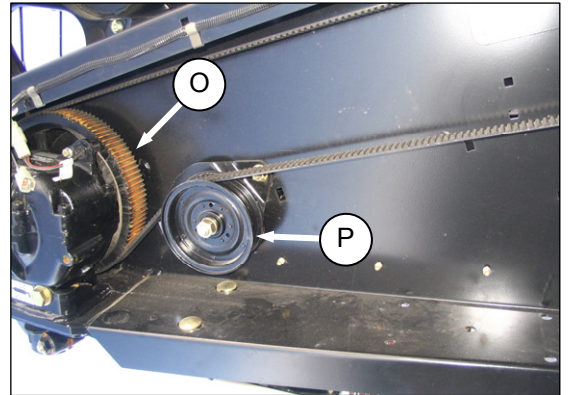

- b. Route belt between the wobble box pulley (O) and the endsheet and locate on wobble box pulley and over idler (P).

#### NOTE

*When installing new belt, never pry belt over pulley. Be sure adjusting device is fully loosened, then tension belt.*

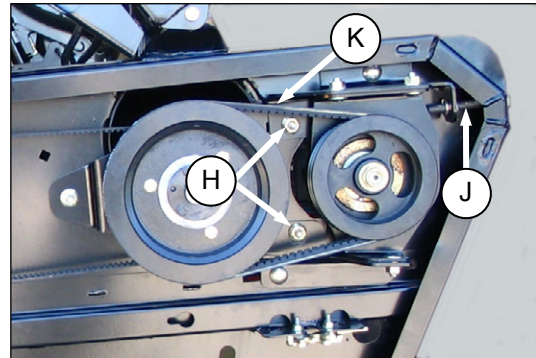

- c. Position V-belts (K) onto drive pulleys.
- d. Turn adjuster bolt (J) to move drive motor until a force of 12 lbf (53 N) deflects V-belts (K) 1/8 in. (3 mm) at mid-span.
- e. Tighten the two bolts (H) on drive mounting brackets.

*(continued next page)*

## SECTION 10. MAINTENANCE AND SERVICING

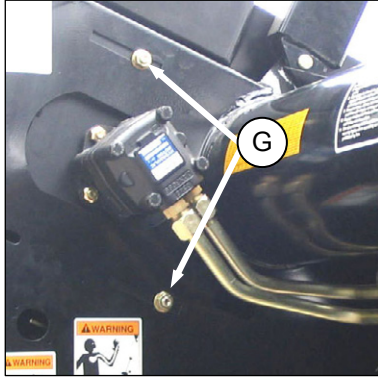

- f. Tighten the two bolts (G) on the endsheet.

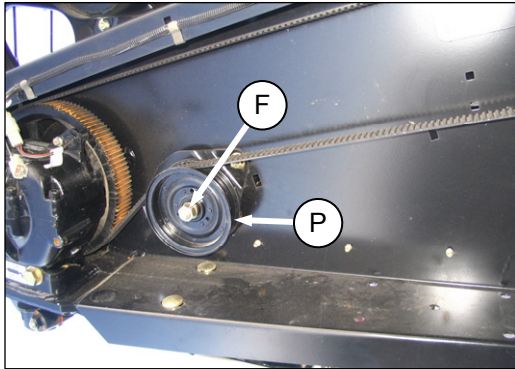

- g. Slide idler (P) up until most of the belt slack is taken up. Tighten idler nut (F).
- h. Adjust the timing belt tension and check belt clearance to belt guide. See 10.11.9.1.1 Tension Adjustment - Timing Belt.
- i. Reinstall plate (L) in the endsheet.
- j. Close left endshield.
- k. Re-adjust tension of a new belt after a short run-in period, (about 5 hours).

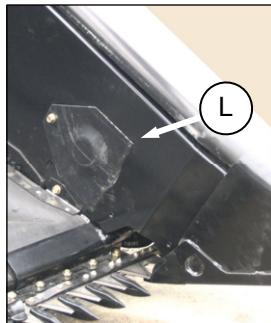

### 10.11.9.1.4 Tension Adjustment - Left Drive Double V-Belts

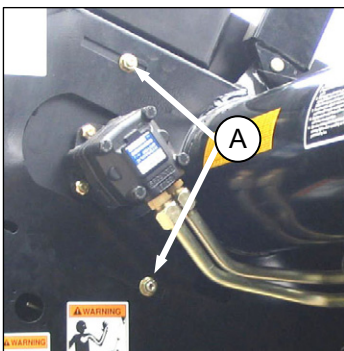

- a. Loosen two bolts (A) on endsheet.

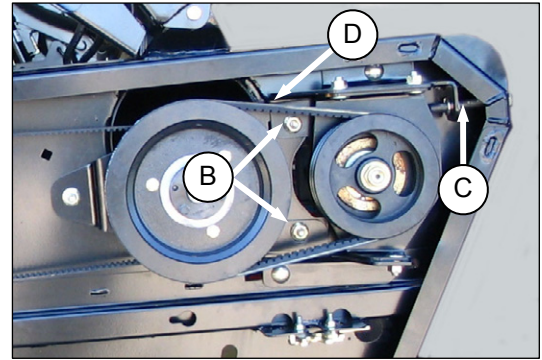

- b. Loosen two bolts (B) on sickle drive mounting bracket.
- c. Turn adjuster bolt (C) to move drive motor until a force of 12 lbf (53 N) deflects V-belts (D) 1/8 in. (3 mm) at mid-span.
- d. Tighten bolts (A) and (B).
- e. Re-adjust tension of a new belt after a short run-in period, (about 5 hours).

### 10.11.9.1.5 Removal - Left Drive V-Belts

- a. Loosen two bolts (A) on endsheet.
- b. Loosen two bolts (B) on sickle drive mounting bracket.
- c. Turn adjuster bolt (C) to loosen the two V-belts (D) and remove belts.

### 10.11.9.1.6 Installation - Left Drive V-Belts

#### IMPORTANT

Sickle drive V-belts are a matched set. Replace both drive belts even if only one needs replacing. Do not pry belt over pulley, loosen adjusting device sufficiently to allow easy installation.

- a. Install belts (D) onto drive pulleys.
- b. Turn adjuster bolt (C) to move drive motor until a force of 12 lbf (53 N) deflects V-belts (D) 1/8 in. (3 mm) at mid-span.
- c. Tighten bolts (A) and (B) on drive mounting bracket.
- d. Re-adjust tension of a new belt after a short run-in period, (about 5 hours).



## SECTION 10. MAINTENANCE AND SERVICING

### 10.11.9.2 Right End Drive



#### CAUTION

To avoid personal injury, before servicing machine or opening drive covers, follow procedures in Section 10.1 PREPARATION FOR SERVICING.

#### 10.11.9.2.1 Tension Adjustment - Timing Belt

##### IMPORTANT

To prolong belt and drive life, do not over-tighten belt.

Refer to 10.11.9.1.1 Tension Adjustment - Timing Belt.

#### 10.11.9.2.2 Removal - Right End Timing Belt

- a. Open right endshield.

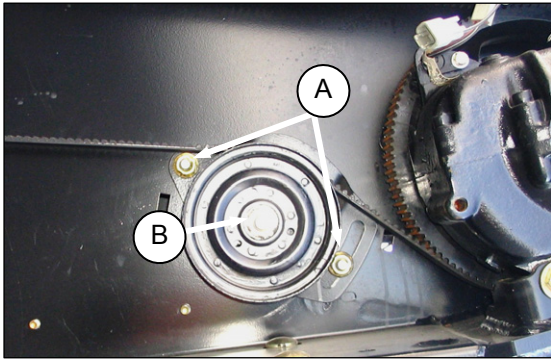

- b. Loosen two nuts (A) on belt idler bracket to relieve tension on belt.
- c. Loosen nut (B) on idler pulley and slide idler down to loosen belt.

- d. Remove bolt in plate (C) in right endsheet at wobble box, and remove the plate. This provides clearance between the pulley and endsheet for the belt when it is removed.

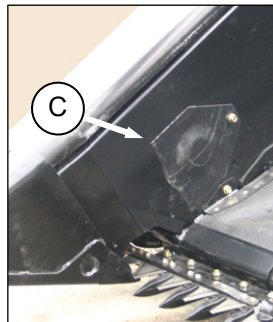

- e. Slip timing belt off wobble box pulley and route the belt between the wobble box pulley and the endsheet.
- f. Remove belt from drive pulley.

#### 10.11.9.2.3 Installation - Right End Timing Belt

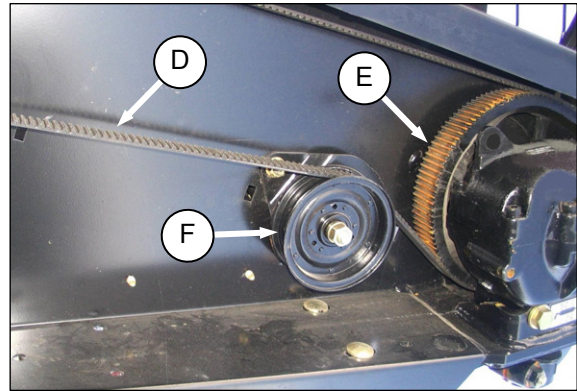

- a. Route timing belt (D) between the wobble box pulley (E) and the endsheet and locate on wobble box pulley and over idler (F).

##### NOTE

When installing new belt, never pry belt over pulley. Be sure adjusting device is fully loosened, then tension belt.

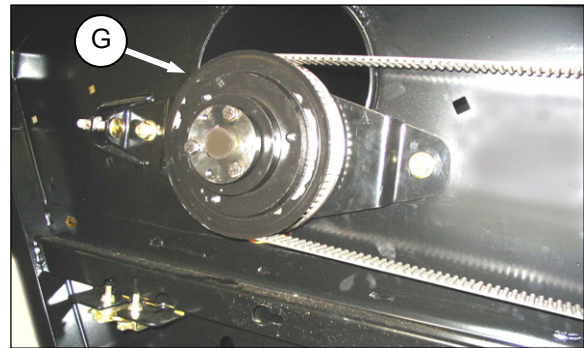

- b. Position timing belt on drive pulley (G).
- c. Adjust the timing belt tension and check belt clearance to belt guide. See 10.11.9.1.1 Tension Adjustment - Timing Belt.

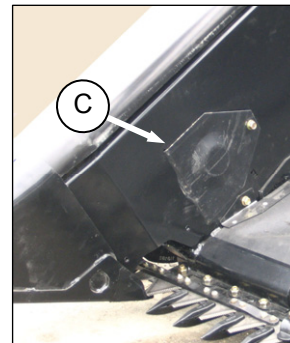

- d. Reinstall plate (C) in endsheet.
- e. Close left endshield.
- f. Re-adjust tension of a new belt after a short run-in period, (about 5 hours).



## SECTION 10. MAINTENANCE AND SERVICING

### 10.11.9.3 Sickle Drive Timing

Double knife D60 Harvest Headers 35 ft. and smaller require that the sickles are properly timed to move in opposite directions.

To adjust the sickle timing, refer to following illustrations and proceed as follows:

- a. Remove the right sickle drive belt. Refer to Section 10.11.9.2.2 Removal - Right End Timing Belt.

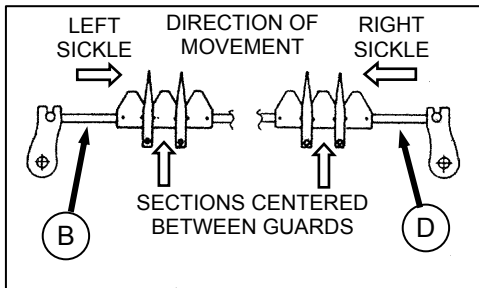
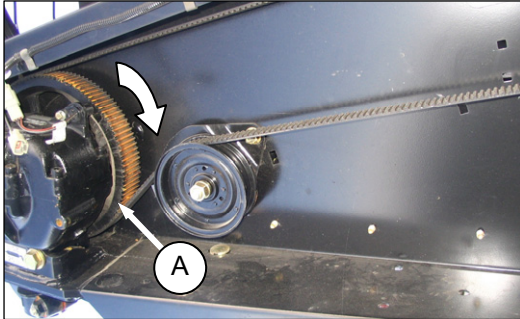

- b. Rotate the left wobble box driven pulley (A) clockwise until the left sickle (B) is at the center of the inboard stroke (moving towards center of header).

#### NOTE

*Center stroke is when the sickle sections are centered between guard points as shown.*

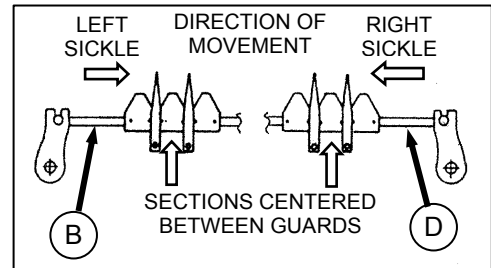
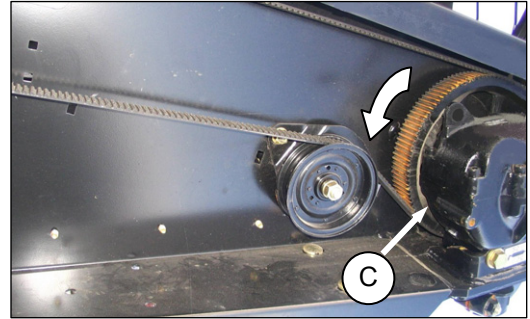

- c. Rotate the right wobble box pulley (C) counter clockwise until the right sickle (D) is at the center of the inboard stroke.
- d. Install the right wobble box drive belt and adjust tension. Refer to Section 10.11.9.2.3 Installation - Right End Timing Belt.

#### IMPORTANT

To maintain timing, wobble box driver and driven pulleys must not rotate as the belt is tightened.

- e. Check that the timing belts are properly seated in the grooves on both driver and driven pulleys.
- f. Check for correct sickle timing by rotating the drive slowly by hand and observe sickles where they overlap at the center of the header.

#### IMPORTANT

Sickles must move in opposite directions and must begin moving at exactly the same time. If timing is off, proceed as follows:

1. Loosen right belt sufficiently to allow skipping the belt one or more teeth as required. Refer to Section 10.11.9.2.1 Tension Adjustment - Timing Belt.
2. If right sickle "leads" left sickle, rotate RIGHT SIDE driven pulley (C) clockwise.
3. If right sickle "lags" left sickle, rotate RIGHT SIDE driven pulley (C) counter clockwise.
4. Tighten right belt.

## SECTION 10. MAINTENANCE AND SERVICING

### 10.11.10 WOBBLE BOX



#### CAUTION

To avoid personal injury, before servicing machine or opening drive covers, follow procedures in Section 10.1 PREPARATION FOR SERVICING.

#### 10.11.10.1 Mounting Bolts

Check four wobble box mounting bolts (B) torque after the first 10 hours operation and every 100 hours thereafter. Torque should be 200 ft·lbf (270 N·m).

When tightening, start with the side mounting bolts.

#### 10.11.10.2 Wobble Box Removal

- Loosen sickle drive belt and slip off wobble box pulley. Refer to Section 10.11.8 Sickle Drive Belts - Non-Timed Drive, and Section 10.11.9 - Double Knife Drive Belts - Timed Drive.
- Remove sickle head pin. Refer to Section 10.11.2 Sickle Removal, steps a. and b.

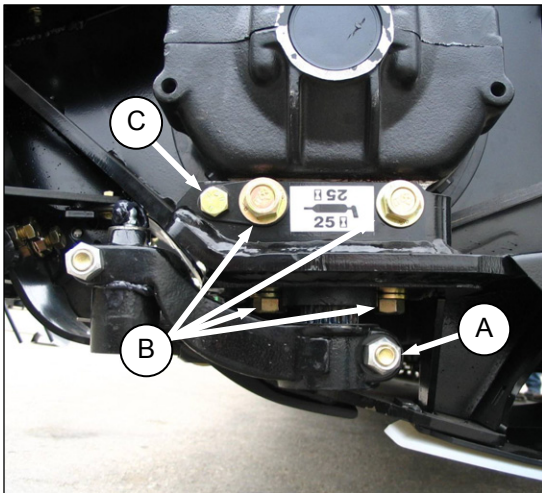

- Remove bolt (A) from pitman arm.
- Remove pitman arm from wobble box shaft.
- Remove bolts (B) attaching wobble box to frame.

#### IMPORTANT

Do not remove or loosen locating tab (C). This is a factory adjustment.

- Remove wobble box.

### 10.11.10.3 Pulley Removal

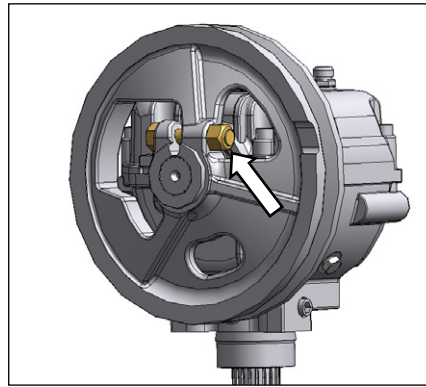

- Loosen nut and bolt from pulley.
- Remove pulley using a 3-jaw puller.

### 10.11.10.4 Pulley Installation

- Remove any rust or paint from shaft and pulley splines. For replacement parts, remove oil/grease with degreasing agent.

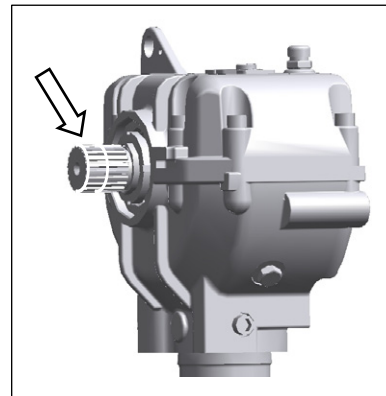

- Apply Loctite® #243 adhesive (or equivalent) to spline. Apply in two bands around shaft as shown, with one band at end of spline and one band approximately mid-way.
- Install pulley on shaft until flush with end of shaft and secure with bolt and nut. Torque bolt to 160 ft·lbf (217 N·m).

## SECTION 10. MAINTENANCE AND SERVICING

### 10.11.10.5 Wobble Box Installation

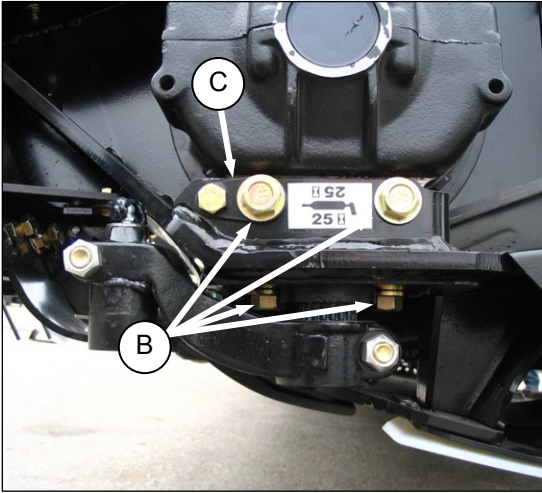

- a. Position wobble box with locating tab (C) at original position and install four bolts (B). Torque side bolts and then bottom bolts to 200 ft-lbf (270 N-m).

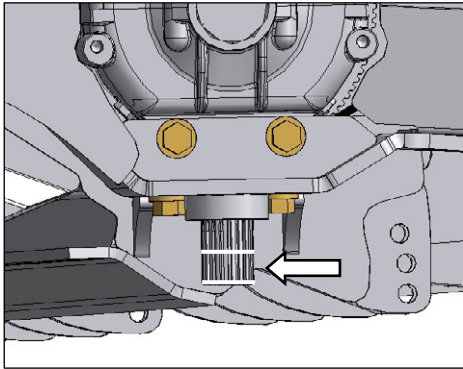

- b. Apply Loctite® #243 adhesive (or equivalent) to spline. Apply in two bands around shaft as shown, with one band at end of spline and one band approximately mid-way.
- c. Remove any rust or paint from pitman arm splines. For replacement parts, remove oil/grease with degreasing agent.

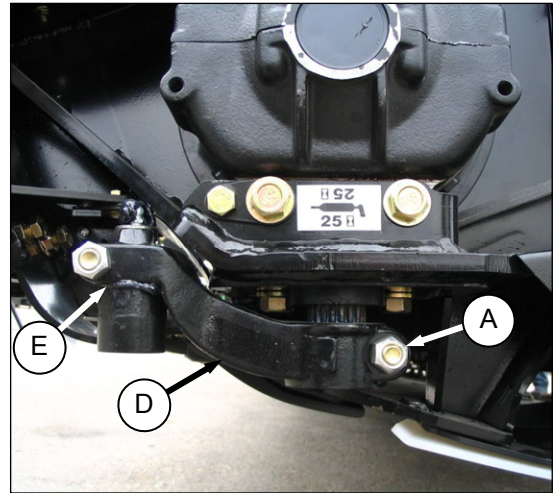

- d. Slide pitman arm (D) onto output shaft.
- e. Slide arm up or down on shaft until it just contacts knifehead (0.010 in. (0.25 mm) gap) (E).
- f. Rotate pulley to ensure drive arm just clears frame to ensure proper placement on splines. Position pitman arm at furthest outboard position.
- g. Install bolt (A) and nut and torque to 160 ft-lb. (217 N-m).
- h. Install sickle head pin. Refer to Section 10.11.4 Sickle Installation.
- i. Install drive belt onto wobble box pulley and tighten. Refer to Section 10.11.8 Sickle Drive Belts - Non-Timed Drive, and Section 10.11.9 - Double Knife Drive Belts - Timed Drive.



## SECTION 10. MAINTENANCE AND SERVICING

### 10.11.10.6 Changing Oil

#### NOTE

*Change wobble box lubricant after the first 50 hours of operation and every 1000 hours (or 3 years) thereafter.*

- a. Raise header to allow a suitable container to be placed under wobble box drain to collect oil.
- b. Open endshield(s).

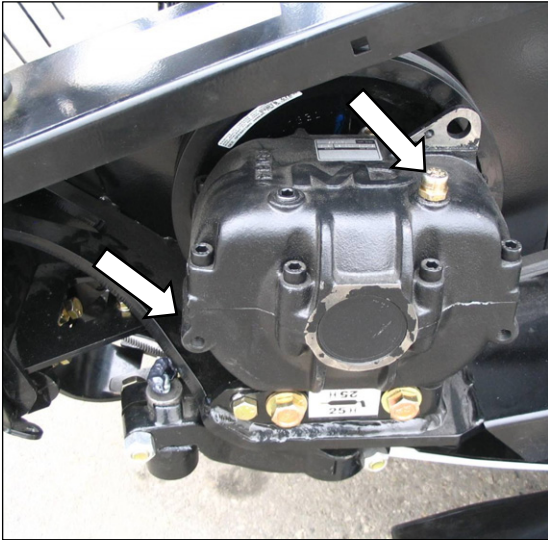

- c. Remove breather/dipstick and drain plug.
- d. Reinstall drain plug and add 2.3 U.S. quarts (2.2 litres) SAE 85W-140 oil to required level.
- e. Close endshield(s).

## SECTION 10. MAINTENANCE AND SERVICING

### 10.12 ADAPTER FEED DRAPER



#### CAUTION

To avoid personal injury, before servicing machine or opening drive covers, follow procedures in Section 10.1 PREPARATION FOR SERVICING.

#### 10.12.1 DRAPER TENSION ADJUSTMENT

Draper tension should be just enough to prevent slipping and keep draper from sagging below cutterbar. Set draper tension as follows:



#### DANGER

To avoid bodily injury or death from fall of raised machine, always engage lift cylinder stops before going under header for any reason. See your Combine Operator's Manual for instructions for use and storage of header lift cylinder stops.



#### CAUTION

Stop engine and remove key from ignition before leaving Operator's seat for any reason. A child or even a pet could engage an idling machine.

- Raise header fully, stop engine, and remove key. Engage header lift cylinder stops.
- Check that draper guide (rubber track on underside of draper) is properly engaged in groove of drive roller and that idler roller is between the guides.

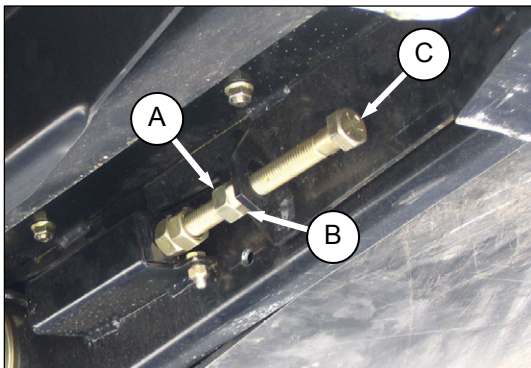

- Loosen jam-nut (A).
- Hold nut (B) with a wrench and turn bolt (C) clockwise to increase tension.

#### IMPORTANT

Adjust both sides equal amounts.

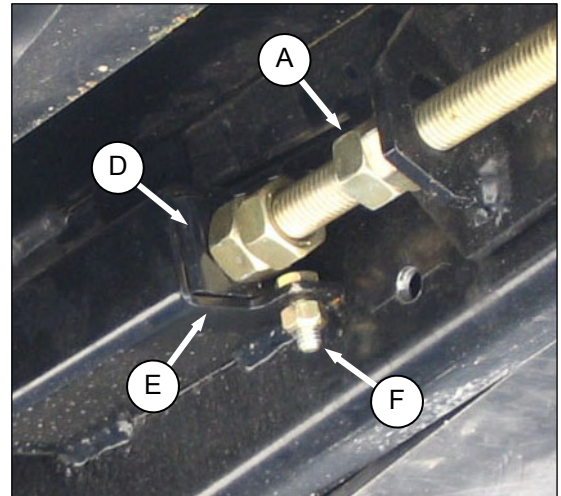

- Correct tension is when retainer (D) is flush with bracket (E), and bolt (F) is free.
- Tighten jam-nut (A).

#### 10.12.2 REPLACING DRAPER

The draper should be replaced or repaired if they are torn, missing slats, or cracked.

- If adapter is attached to combine and header, disconnect header. Refer to Section 8 HEADER/ADAPTER DISASSEMBLY AND ASSEMBLY.
- Raise header fully, stop engine, and remove key. Engage header lift cylinder stops.



#### CAUTION

Stop engine and remove key from ignition before leaving Operator's seat for any reason. A child or even a pet could engage an idling machine.

- Loosen draper as follows:
  - Loosen jam-nut (A).
  - Hold nut (B) with a wrench and turn bolt (C) counter clockwise to release tension.
- Repeat on opposite side of adapter.
- Disengage header lift cylinder stops, and lower feeder house and adapter onto blocks to keep adapter slightly off the ground.

*(continued next page)*

## SECTION 10. MAINTENANCE AND SERVICING

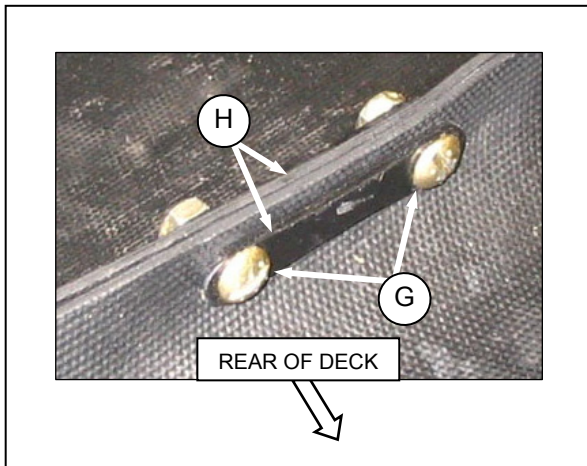

- f. Remove nuts, screws (G), and straps (H) along draper joint.
- g. Pull draper from deck.

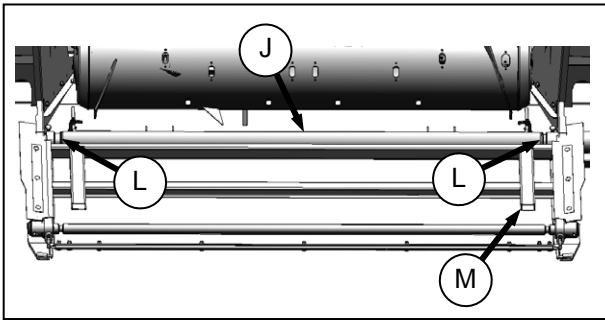

- h. Install new draper over drive roller (J) with chevron cleat (K) pointing to front of adapter, and ensuring draper guides fit in drive roller grooves (L).
- i. Pull draper along bottom of adapter deck and over draper supports (M).
- j. Connect draper with straps (H), screws (G) and nuts with screw heads facing rear of deck. Tighten nuts so that end of screw is approximately flush with nut.
- k. Adjust draper tension. Refer to Section 10.12.1 Draper Tension Adjustment.



## SECTION 10. MAINTENANCE AND SERVICING

### 10.13 HEADER DRAPERS



#### CAUTION

To avoid personal injury, before servicing machine or opening drive covers, follow procedures in Section 10.1 PREPARATION FOR SERVICING.

#### 10.13.1 HEADER DRAPER TENSION ADJUSTMENT

Draper tension should be just enough to prevent slipping and keep draper from sagging below cutterbar. Set draper tension as follows:

- Check that draper guide (rubber track on underside of draper) is properly engaged in groove of drive roller and that idler roller is between the guides.

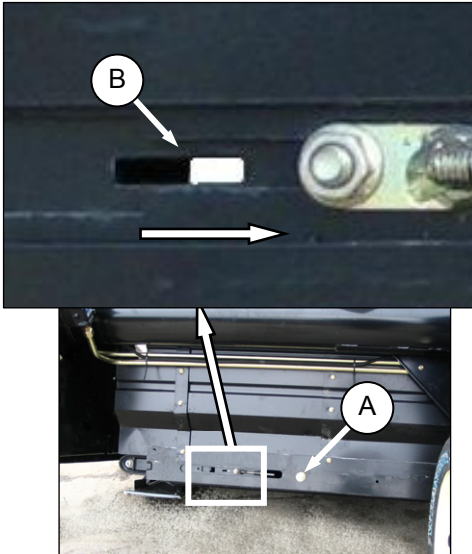

- Turn bolt (A) clockwise (tighten) and white indicator bar (B) will move inboard in direction of arrow to indicate that draper is tightening. Tighten until bar is about halfway in window.

#### IMPORTANT

To avoid premature failure of draper, draper rollers and/or tightener components, do not operate with tension set so that white bar is not visible.

Also to prevent the draper from scooping dirt, ensure draper is tight enough that it does not sag below point where cutterbar contacts the ground.

### 10.13.2 REPLACING SPLIT DRAPER

The draper should be replaced or repaired if it is torn, missing slats, or cracked.



#### CAUTION

To avoid bodily injury from fall of raised reel, always engage reel props before going under raised reel for any reason.



#### DANGER

To avoid bodily injury or death from unexpected start-up or fall of raised machine, stop engine, remove key and engage lift cylinder locks before going under machine for any reason.

#### 10.13.2.1 Draper Removal

- Raise reel and engage reel props.
- Raise header and install lift cylinder locks.
- Stand in draper opening or on combine feed draper and move draper until draper joint is in work area.

#### NOTE

*Deck can also be shifted towards center to provide opening at endsheet.*

- Release tension on the draper. Refer to previous section.

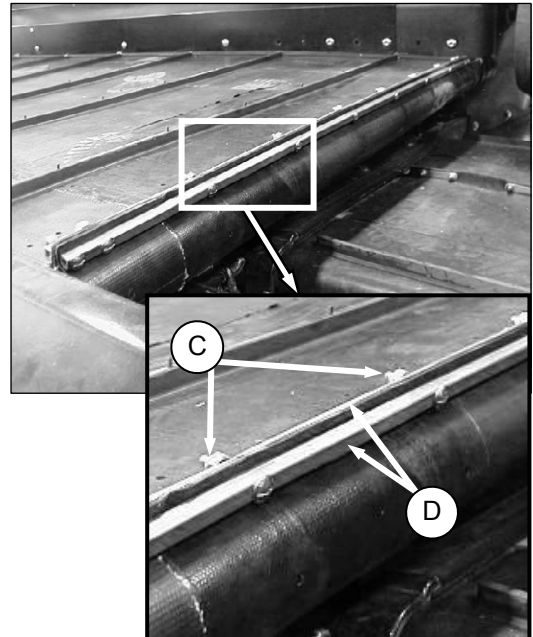

- Remove nuts (C) and tube connectors (D) at draper joint.
- Pull draper from deck.

## SECTION 10. MAINTENANCE AND SERVICING

### 10.13.2.2 Draper Installation



- a. Insert draper into deck at outboard end, under the rollers. Pull draper into deck while feeding it at the end.
- b. Feed in the draper until it can be wrapped around the drive roller.
- c. Similarly insert the other end into the deck over the rollers. Pull draper fully into the deck.

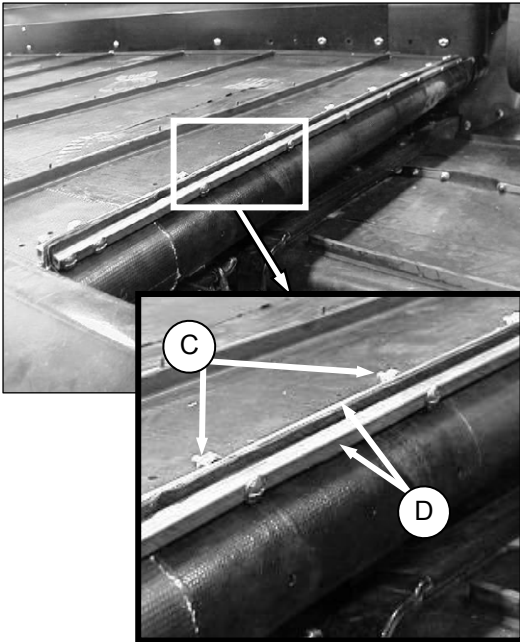

- d. Attach ends of draper with tube connectors (D).
- e. Install screws (C) with heads facing the center opening.
- f. Adjust tension. Refer to Section 10.13.1 Header Draper Tension Adjustment.

## SECTION 10. MAINTENANCE AND SERVICING

### 10.13.3 HEADER DRAPER ALIGNMENT

Each draper deck has one fixed roller and one spring-loaded roller. The spring-loaded roller is located at the same end of the deck as the draper tensioner.

Both rollers can be aligned by adjuster rods so that the draper tracks properly on the rollers.



#### CAUTION

**To avoid personal injury, before servicing machine or opening drive covers, follow procedures in Section 10.1 PREPARATION FOR SERVICING.**

If the draper is tracking incorrectly, make the following adjustments to the rollers:

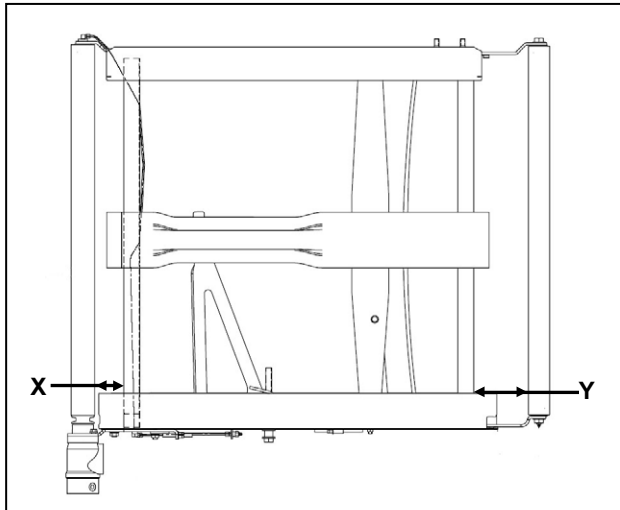

TRACKING	AT LOCATION	ADJUSTMENT	METHOD
Backward	Drive Roller	INCREASE 'X'	Tighten Nut 'C'
Forward		DECREASE 'X'	Loosen Nut 'C'
Backward	Idler Roller	INCREASE 'Y'	Tighten Nut 'F'
Forward		DECREASE 'Y'	Loosen Nut 'F'

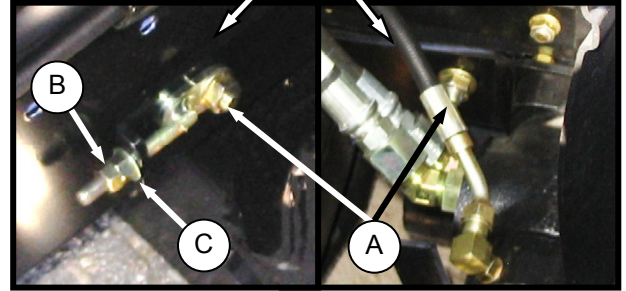
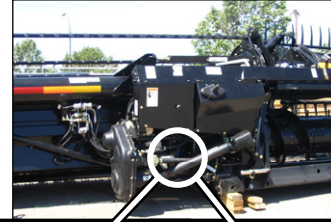

LH DRIVE ROLLER ADJUST - RH OPPOSITE

- g. Adjust the drive roller 'X' by loosening nuts (A), jam-nut (B) on adjuster rod, and turning the adjusting nut (C).

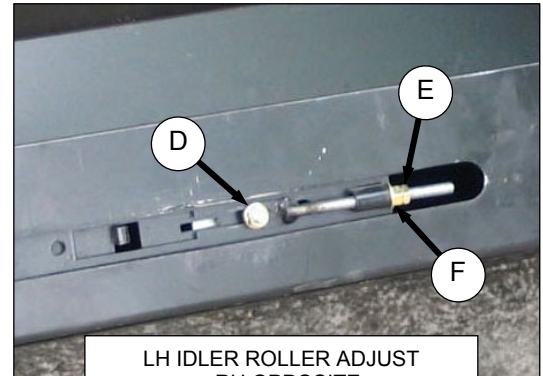

LH IDLER ROLLER ADJUST - RH OPPOSITE

- b. Adjust the idler roller 'Y' by loosening nut (D), jam-nut (E) on adjuster rod and turning adjusting nut (F).
- c. If the draper will not track at the idler roller end, the drive roller is likely not square to the deck. Adjust the drive roller and then re-adjust the idler.



## SECTION 10. MAINTENANCE AND SERVICING

### 10.13.4 DRAPER ROLLER MAINTENANCE

The draper rollers have non-greaseable bearings.

The external seal should be checked every 200 hours, or more frequently in sandy conditions, to obtain the maximum bearing life.



#### **DANGER**

**Engage header lift cylinder stops and reel props before working under header or reel.**

#### 10.13.4.1 Drive Roller Removal

- Raise header and reel and engage cylinder and reel stops.
- On deck shift headers, position deck so drive roller is easily accessible.
- Loosen and uncouple draper. Refer to Section 10.13.2 Replacing Split Draper.

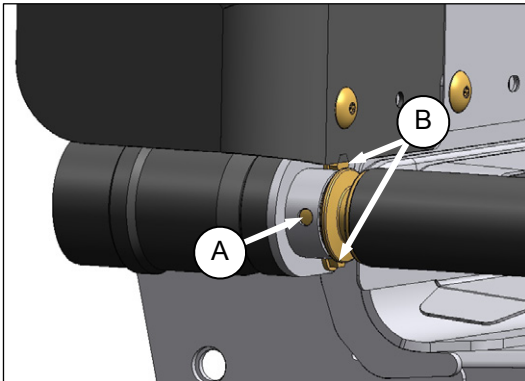

- Loosen the two set screws in access hole (A) in the drive roller hub at motor end.
- Remove the two bolts (B) that hold hydraulic motor to arm and pull motor off roller.

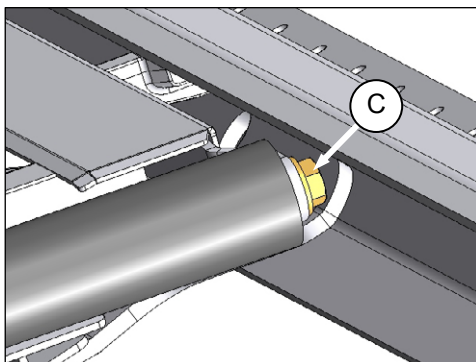

- Remove bolt (C) at forward end of roller and remove roller from deck.

#### 10.13.4.2 Drive Roller Installation



#### **DANGER**

**Engage header lift cylinder stops and reel props before working under header or reel.**

Refer to illustrations opposite.

- Position roller in deck arms and secure forward end with bolt (C) and washer. Do not tighten at this time.
- Apply SAE Multi-Purpose grease to motor shaft, locate motor on roller arm and engage motor shaft into roller.
- Secure motor with bolts (B) and tighten.
- Push roller against shoulder on motor shaft and hand tighten the two set screws (A). Torque set screws to 20 ft·lbf (27 N·m).
- Torque bolt (C) to 70 ft·lbf (95 N·m).
- Re-attach draper. Refer to Section 10.13.2 Replacing Split Draper.
- Adjust draper tension. Refer to Section 10.13.1 Header Draper Tension Adjustment.
- Readjust hydraulic motor hoses if required and tighten hose clamps.
- Run machine and adjust tracking if required. Section 10.13.3 Header Draper Alignment.

## SECTION 10. MAINTENANCE AND SERVICING

### 10.13.4.3 Idler Roller Removal



#### DANGER

Engage header lift cylinder stops and reel props before working under header or reel.

- Raise header and reel and engage cylinder and reel stops.
- On deck shift headers, position deck so idler roller is easily accessible.
- Loosen and uncouple draper. Refer to Section 10.13.2.1 Draper Removal.

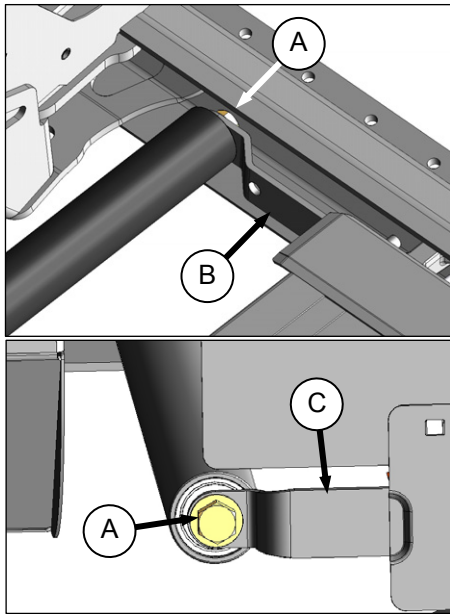

- Remove bolts (A) and washer at ends of idler roller.
- Spread roller arms (B) and (C) and remove roller.

### 10.13.4.4 Idler Roller Installation

See illustration opposite.

- Position stub shaft in idler roller in forward arm (B) on deck.
- Push on roller to deflect forward arm slightly so that stub shaft at rear of roller can be slipped into rear arm (C).
- Install bolts (A) with washers and torque to 70 ft·lbf (93 N·m).
- Re-attach draper. Refer to Section 10.13.2 Replacing Split Draper.
- Adjust draper tension. Refer to Section 10.13.1 Header Draper Tension Adjustment.
- Run machine and adjust tracking if required. Refer to Section 10.13.3 Header Draper Alignment.

### 10.13.4.5 Draper Roller Bearing/Seal Replacement

#### NOTE

Seal (D) not included in D50 header.

- Remove roller assembly. Refer to Section 10.13.4.1 Drive Roller Removal or Section 10.13.4.3 Idler Roller Removal.

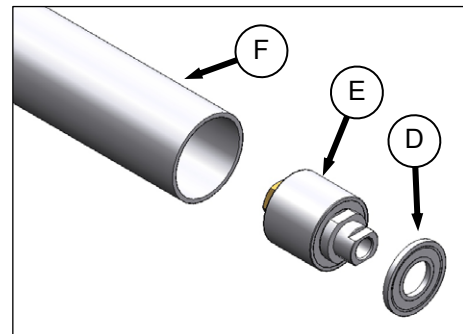

- Remove bearing assembly (E) and seal (D) from roller tube (F) as follows:

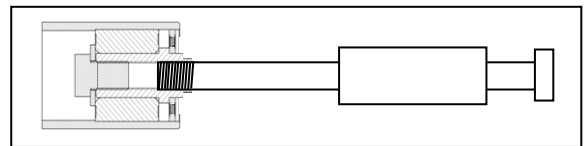

- Attach a slide hammer to threaded shaft.
  - Tap out the bearing assembly.
- Clean inside of roller tube (F). Check tube for wear or damage. Replace if necessary.

(continued next page)

## SECTION 10. MAINTENANCE AND SERVICING

d. Install bearing and seal as follows:

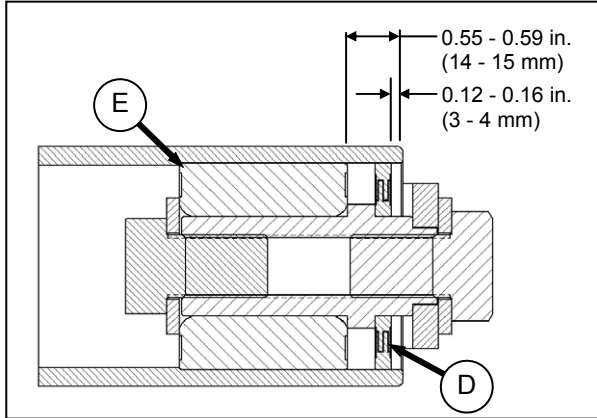

1. Install bearing assembly (E) into roller by pushing on outer race of bearing. The bearing is fully positioned when the 0.55 inch (14 mm) dimension is achieved. See illustration below.
  2. Apply grease in front of bearing. Refer to Section 10.3.4 Recommended Fluids and Lubricants.
- e. Install seal (D) as follows:
1. Locate seal at roller opening and position a flat washer (1.0 inch I.D. X 2.0 in. O.D.) on seal.
  2. Using a suitable socket to locate on the washer, tap seal into roller opening until it seats on the bearing assembly. The seal is fully positioned when the 0.12 in. (3 mm) dimension is achieved. See illustration above.
- f. Re-install roller assembly. Refer to Section 10.13.4 Draper Roller Maintenance.



## SECTION 10. MAINTENANCE AND SERVICING

### 10.13.5 DECK HEIGHT

To prevent material from entering drapers and cutterbar, maintain deck height so that draper runs just below cutterbar with maximum 1/32 in. (1 mm) gap, or with draper deflected down slightly [up to 1/16 in. (1.5 mm)] to create a seal.

The illustration shows the adjustment without the draper.

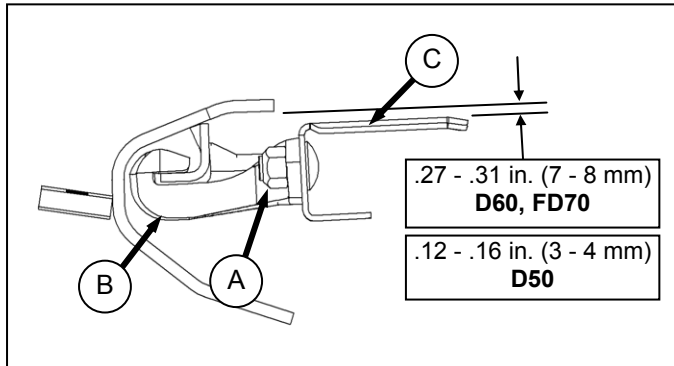

Adjust as follows:



### DANGER

Engage header lift cylinder stops and reel props before working under header or reel.



### DANGER

To avoid bodily injury or death from unexpected start-up or fall of raised machine, stop engine, remove key and engage lift cylinder locks before going under machine for any reason.

- Loosen tension on draper. Refer to Section 10.13.1 Header Draper Tension Adjustment.
- Lift draper up at front edge past cutterbar.

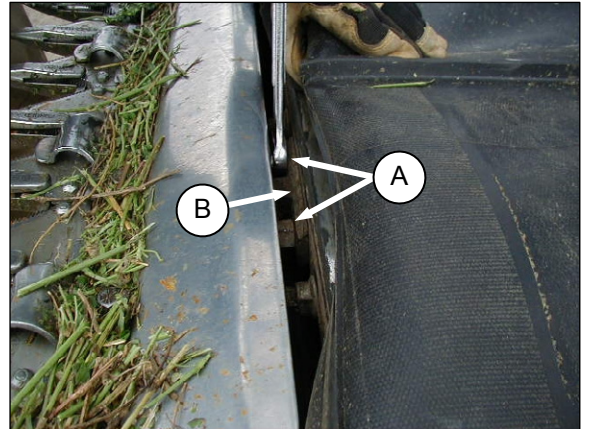

- Loosen two lock-nuts (A) (four if it is an endless draper) a half-turn only on deck support (B). There are two to four supports per deck, depending on header size.
- Tap deck (C) to lower deck relative to supports to achieve setting recommended above. Tap support (B) using a punch to raise deck relative to support.
- Tighten deck support hardware (A).
- Tension draper. Refer to Section 10.13.1 Header Draper Tension Adjustment.

## SECTION 10. MAINTENANCE AND SERVICING

### 10.14 REEL AND REEL DRIVE



#### CAUTION

To avoid personal injury, before servicing header or opening drive covers, follow procedures in Section 10.1 PREPARATION FOR SERVICING.

#### 10.14.1 REEL CLEARANCE TO CUTTERBAR - D50, D60

The finger to guard/cutterbar clearances with reel fully lowered varies with header width and are as follows. See illustration opposite.

HEADER	'X' +/- .12 in. (3 mm) @ ENDSHEETS	
	SINGLE REEL	DOUBLE REEL
20 FOOT	.78 in. (20mm)	---
25 FOOT	1.00 in. (25 mm)	---
30 FOOT	1.77 in. (45 mm)	0.78 in. (20 mm)
35 FOOT	2.36 in. (60 mm)	0.78 in. (20 mm)
40 FOOT	---	0.78 in. (20 mm)
45 FOOT	---	0.78 in. (20 mm)

##### 10.14.1.1 Clearance Measurement - D50, D60



#### DANGER

To avoid bodily injury or death from unexpected start-up or fall of raised machine, stop engine, remove key and engage lift cylinder locks before going under machine for any reason.

- a. Raise header, engage header lift cylinder stops, and lower header onto stops.
- b. Lower the reel fully.

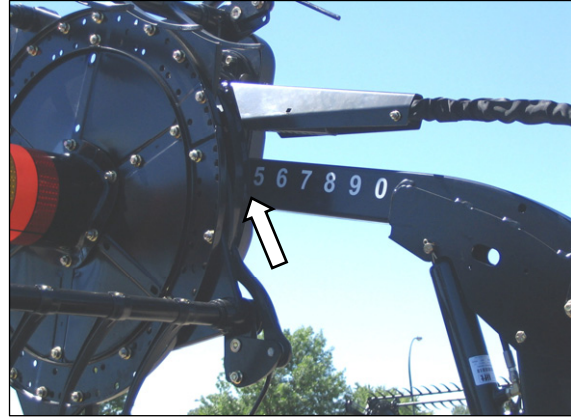

- c. Adjust fore-aft reel position so that back end of cam disc is approximately between 4 and 5 on the arm decal.

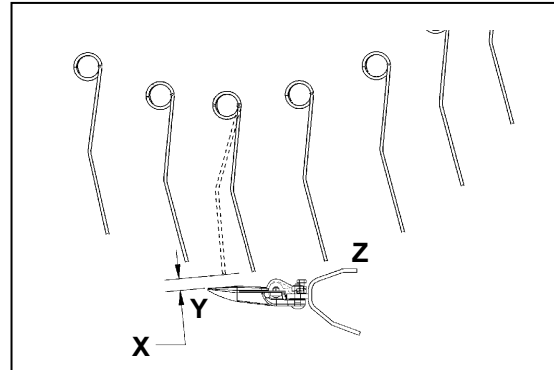

- d. Measure clearance 'X' at ends of each reel.

#### NOTE

*The reel has been adjusted at the factory to provide more clearance at the center of the reel than at the ends (frown) to compensate for reel flexing.*

- e. Check all possible points of contact between points 'Y' and 'Z'. Depending on reel fore-aft position, minimum clearance can occur at guard tine, hold-down or cutterbar.
- f. If adjustment is required, refer to following section.

## SECTION 10. MAINTENANCE AND SERVICING

### 10.14.1.2 Reel Clearance Adjustment - D50, D60



#### DANGER

Engage header lift cylinder stops before working under header.

- Raise header, engage header lift cylinder stops, and lower header onto stops.
- Lower the reel fully.
- Adjust outside arms as follows:

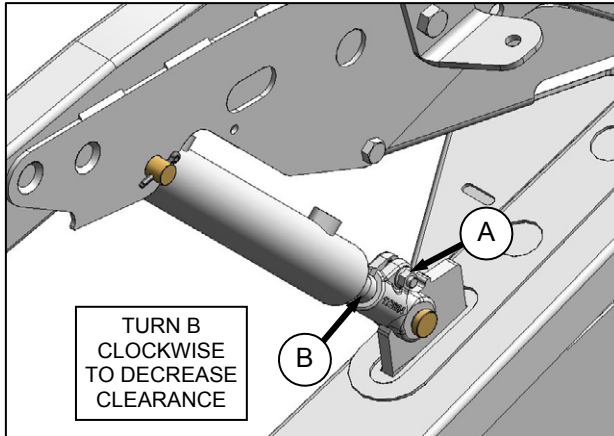

- Loosen bolt (A).
  - Turn cylinder rod (B) counter clockwise to raise reel and increase clearance to cutterbar, or clockwise to decrease.
  - Tighten bolt (A).
  - Repeat at opposite side.
- d. For double reel (D60 only), adjust center arm as follows:

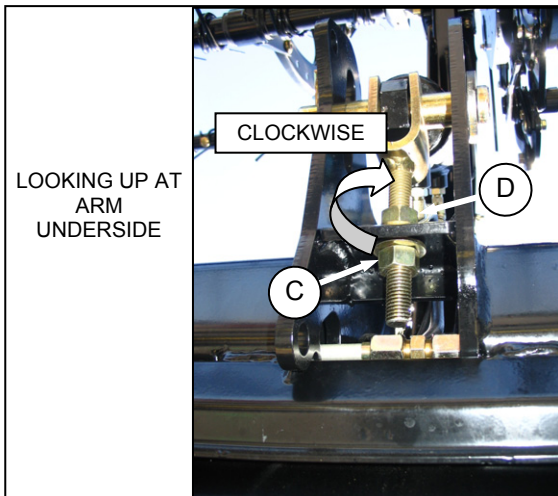

- Loosen nut (C), and turn nut (D) clockwise to raise reel and increase clearance to cutterbar, or counter clockwise to decrease.

### 10.14.2 REEL CLEARANCE TO CUTTERBAR - FD70

The finger to guard/cutterbar clearance with reels fully lowered is 0.78 in. (20 mm) +/- 0.12 in. (3 mm) measured **at both ends of each reel, and at the cutterbar flex locations** with the header in full frown mode.

#### 10.14.2.1 Clearance Measurement - FD70



#### CAUTION

Engage header lift cylinder stops before working under header.

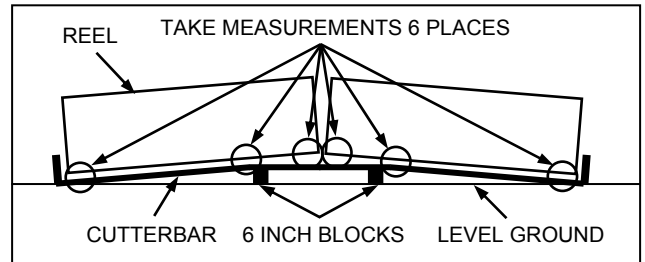

- Raise header and place two 6 in. (150 mm) blocks placed just inboard of wing flex points.
- Lower header fully, allowing it to flex into full frown mode.

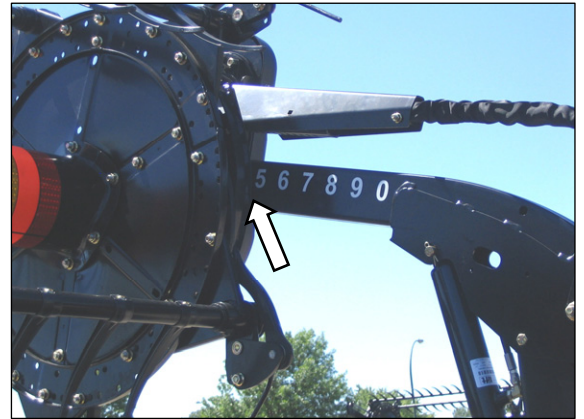

- Adjust fore-aft reel position so that back end of cam disc is approximately between 4 and 5 on the arm decal.
- Measure clearance at ends of each reel.

#### NOTE

The reel has been adjusted at the factory to provide more clearance at the center of the reel than at the ends (frown) to compensate for reel flexing.

- Measure the clearance at both flex locations.

(continued next page)



## SECTION 10. MAINTENANCE AND SERVICING

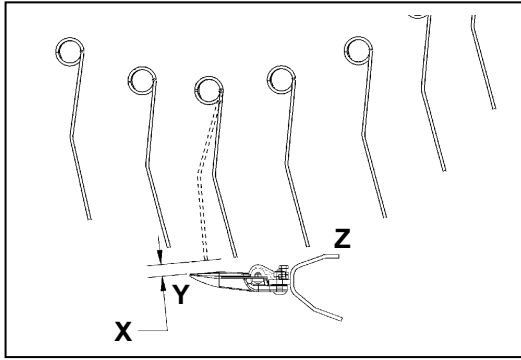

- f. Check all possible points of contact between points 'Y' and 'Z'. Depending on reel fore-aft position, minimum clearance can occur at guard tine, hold-down, or cutterbar.
- g. Refer to following section for adjustment procedure.

### 10.14.2.1.1 Reel Clearance Adjustment - FD70



## DANGER

**Engage header lift cylinder stops before working under header.**

- a. Raise header and place two 6 in. (150 mm) blocks placed just inboard of wing flex points.
- b. Lower header fully, allowing it to flex into full frown mode. See previous section.
- c. Adjust outside arms to change clearance at ends of cutterbar as follows:

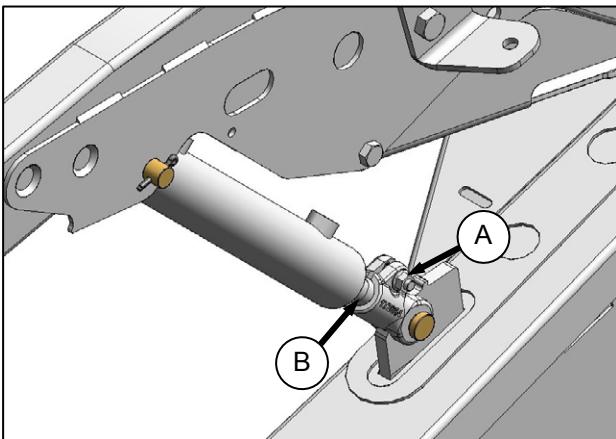

1. Loosen bolt (A).
2. Turn cylinder rod (B) counter clockwise to raise reel and increase clearance to cutterbar, or clockwise to decrease.
3. Tighten bolt (A).
4. Repeat at opposite side.

- d. Adjust center arm to change clearance at center of cutterbar and at flex locations as follows:

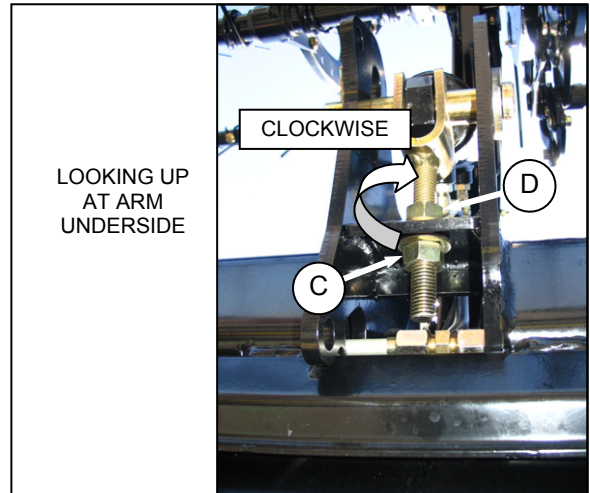

1. Loosen nut (C).
2. Turn nut (D) counter clockwise to raise reel and increase clearance to cutterbar, or clockwise to decrease.
3. Tighten nut (C).

## SECTION 10. MAINTENANCE AND SERVICING

### 10.14.3 REEL FROWN ADJUSTMENT

The reel has been adjusted at the factory to provide more clearance at the center of the reel than at the ends (frown) to compensate for reel flexing.

The “frown” is adjusted by repositioning the hardware connecting reel finger tube arms to reel discs. The frown adjustment compensates for reel flexing.

**IMPORTANT**

The “frown” profile should be measured prior to reel disassembly for servicing so that the profile can be maintained after reassembly.

- a. Position the reel over the cutterbar (4 - 5 on gauge). This position provides adequate clearance at all reel fore-aft positions. Refer to Section 9.11.10 Reel Fore-Aft Position.
- b. Take a measurement at each reel disc location for each reel tube.
- c. Adjust the profile as follows: Start with the reel disc set closest to center of header, and proceed to the ends.

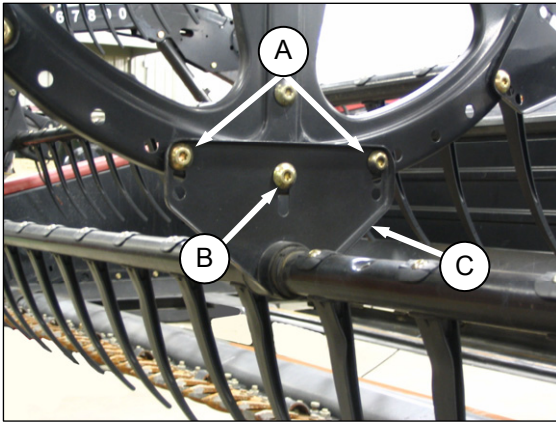

1. Remove bolts (A).
2. Loosen bolt (B) and adjust arm (C) until desired measurement is obtained between reel tube and cutterbar.

**NOTE**

*Allow the reel tubes to find a natural curve and position the hardware appropriately.*

3. Re-install bolts (A) in aligned holes and tighten.

### 10.14.4 REEL CENTERING

#### 10.14.4.1 Double Reel Header

The reels should be centered between the endsheets.

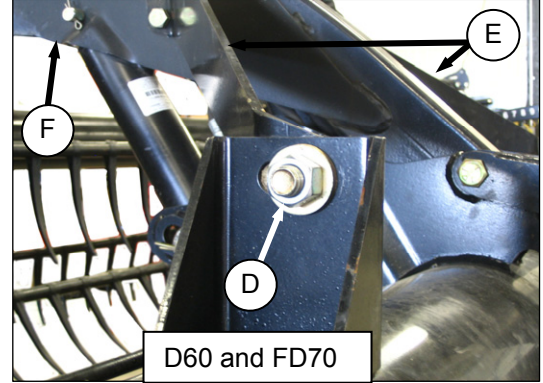

- a. Loosen bolt (D) on each brace (E).
- b. Move forward end of reel center support arm (F) laterally as required to center both reels.
- c. Tighten bolts (D) and torque to 265 ft·lbf (359 N·m).

#### 10.14.4.2 Single Reel Header

The reel should be centered between the endsheets.

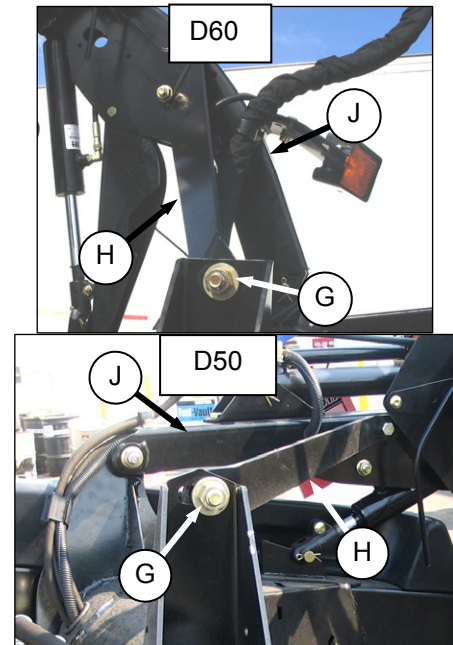

- a. Loosen bolt (G) on brace (H) at both ends of reel.
- b. Move forward end of reel support arm (J) laterally as required to center reel.
- c. Tighten bolts (G) and torque to 265 ft·lbf (359 N·m).

## SECTION 10. MAINTENANCE AND SERVICING

### 10.14.5 REEL DRIVE CHAIN - D60, FD70

#### 10.14.5.1 Tension Adjustment



### DANGER

To avoid bodily injury from fall of raised reel, always engage reel props before going under raised reel for any reason.

- Lower header, raise reel and engage reel props.

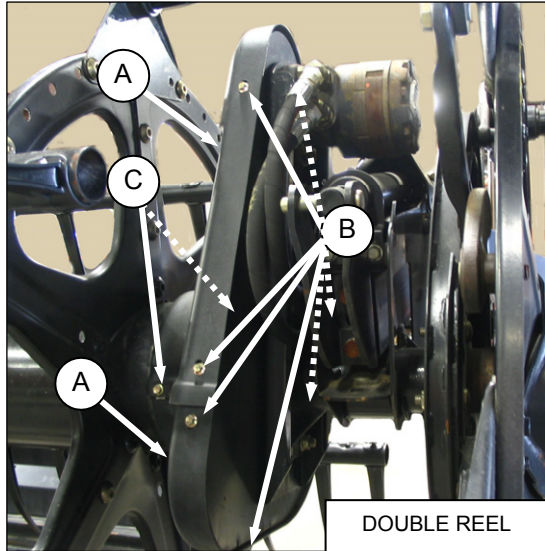

- On a double reel header, the drive is located on the center reel arm. Remove drive cover (A) by removing seven screws (B) and two screws (C). The cover comes off in two pieces.

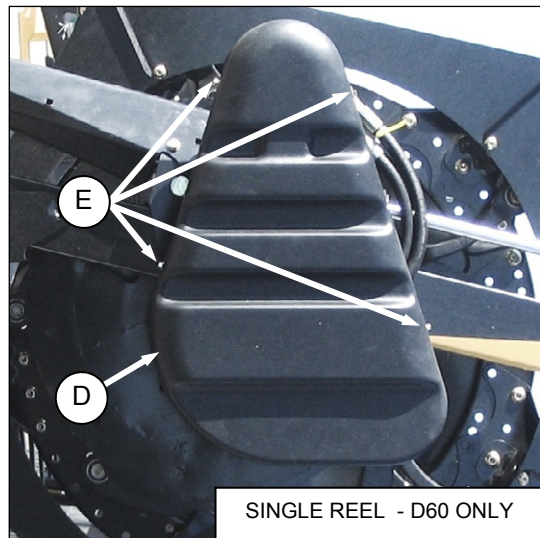

- On a D60 single reel header, the drive is located on the right outside arm. Remove the one piece cover (D) by removing four screws (E).

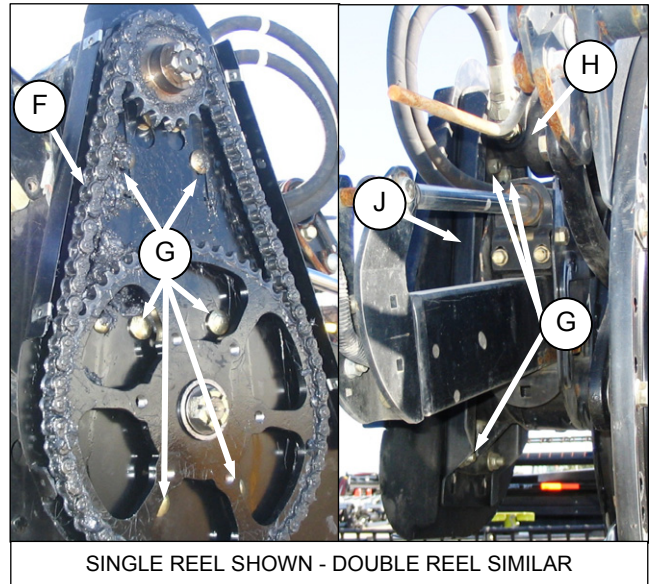

- The tension on the chain (F) should be such that hand force deflects the chain 1/8 inch (3 mm) at mid-span. Adjust as follows:
- Loosen six bolts (G) on motor mount.
- Slide the motor (H) and motor mount (J) until the required tension is achieved.
- Tighten bolts (G) to 75 ft·lbf (102 N·m).
- Re-install drive cover(s).

#### NOTE

*On double reel headers, install screws (C) after both cover halves have been positioned.*



## SECTION 10. MAINTENANCE AND SERVICING

### 10.14.5.2 Replacing Drive Chain - D60 Single Reel



#### DANGER

To avoid bodily injury from fall of raised reel, always engage reel props before going under raised reel for any reason.

#### Removal

- Remove reel drive cover. Refer to previous section.

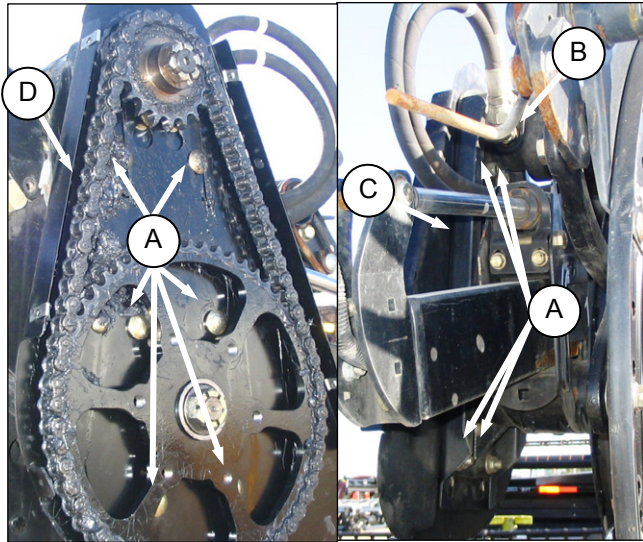

- Loosen bolts (A) and slide motor (B) and motor mount (C) down towards reel shaft.
- Remove chain (D).

#### Installation

- Position chain (D) around sprockets as shown opposite.
- Slide the motor (B) and motor mount (C) until the tension on the chain (D) is such that hand force deflects the chain 1/8 inch (3 mm) at mid-span.
- Tighten nuts (A) and recheck tension.
- Reinstall drive cover.

### 10.14.5.3 Replacing Drive Chain - D60, FD70 Double Reel

#### Removal

- Remove reel drive cover. Refer to previous section.

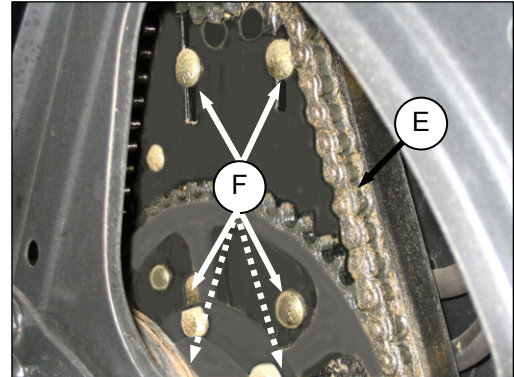

- Loosen six bolts (F).

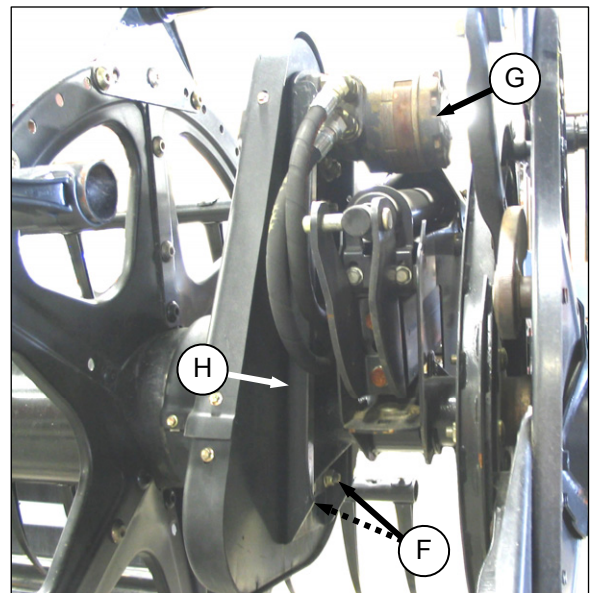

- Slide motor (G) and motor mount (H) down towards reel shaft to loosen chain.

The endless chain (E) can be replaced by:

- Method 1** - Disconnecting the reel drive,

#### OR

- Method 2** - By breaking the chain and installing a new chain with a connector link.

Method 1 is preferred because the chain integrity is not affected.

*(continued next page)*

## SECTION 10. MAINTENANCE AND SERVICING

### 10.14.5.3.1 Disconnecting the Reel Drive (Method 1):



1. Support inboard end of right reel with a front end loader and nylon slings (or equivalent set-up).

#### IMPORTANT

To avoid damaging or denting center tube, support reel as close as possible to the end disc.

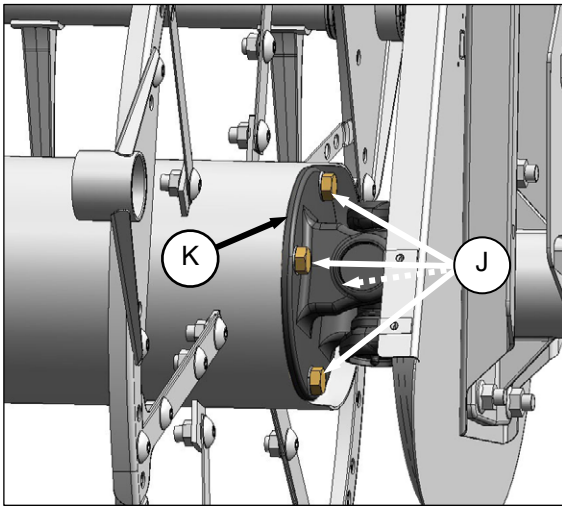

2. Remove four bolts (J) attaching reel tube to U-joint (K).
3. Loosen the RH reel arm brace (D60).
4. Move RH reel sideways to separate the reel tube and the U-Joint (K).
5. Remove the chain.

### 10.14.5.3.2 Break the Chain (Method 2):

1. Grind off head of a link rivet on chain (E), punch out the rivet and remove chain.

### Installation

The endless chain (E) can be installed by:

- **Method 1** - Disconnecting the reel drive,  
**OR**
- **Method 2** - By breaking the new chain, and installing it with a connector link.

Method 1 is preferred because the chain integrity is not affected.

### 10.14.5.3.3 Disconnecting the Reel Drive (Method 1):

1. If not already disconnected, disconnect reel drive as described in 10.14.5.3.1 opposite.

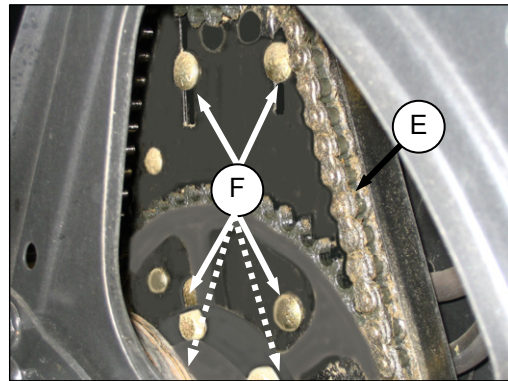

2. Route new chain (E) over U-Joint (K) and locate on sprockets.

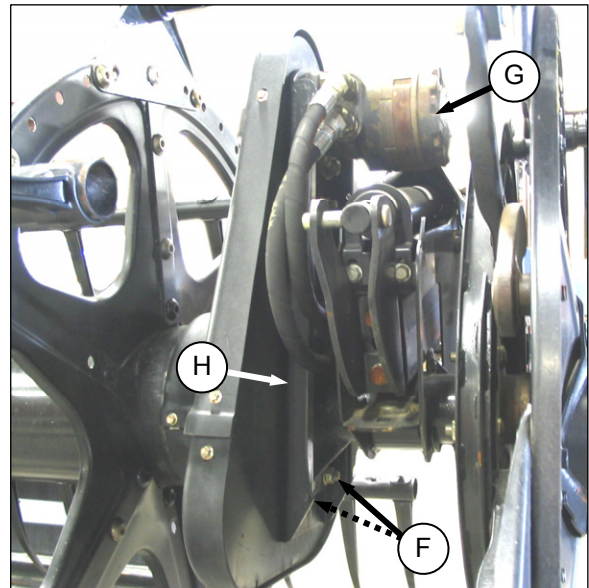

3. Slide the motor (G) and motor mount (H) until the tension on the chain is such that hand force deflects the chain 1/8 inch (3 mm) at mid-span.
4. Tighten nuts (F) and recheck tension.

(continued next page)



## SECTION 10. MAINTENANCE AND SERVICING

5. Position RH reel tube against reel drive and engage stub shaft into U-joint (K) pilot hole.
6. Rotate reel until holes in end of reel tube and U-joint line up.

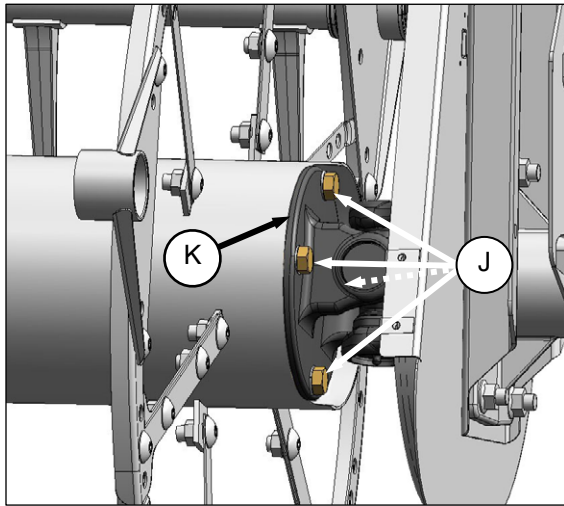

7. Apply Loctite® 243 (or equivalent) to four ½” bolts (J) and install with lock-washers.
8. Torque to 75-85 ft·lbf (102-115 N·m).
9. Tighten RH reel arm brace (D60).
10. Remove temporary reel support.
11. Reinstall drive covers.

### 10.14.5.3.4 Breaking the Chain (Method 2).

1. Grind off the head from one of the link rivets and punch out the rivet to separate the chain.
2. Locate ends of chain on sprocket.

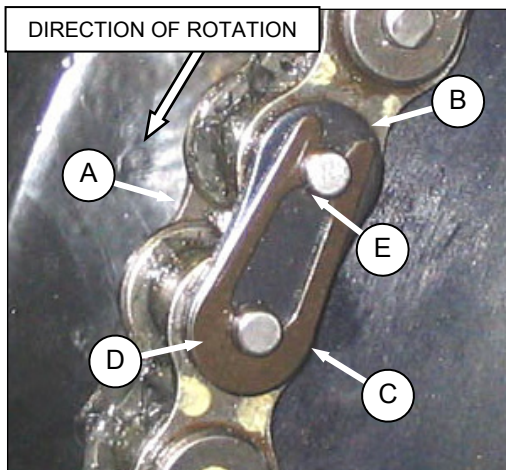

3. Install pin connector (A) (not available as a MacDon part) into chain, preferably from the sprocket backside.
4. Install connector (B) onto pins.

5. Install spring clip (C) onto front pin (D) with closed end of clip in direction of sprocket rotation.
6. Locate one leg of clip in groove of aft pin (E).
7. Press other leg of spring clip over face of aft pin (E) until it slips into groove. Do not press clip lengthwise from closed end.
8. Ensure clip is seated in grooves of pins.

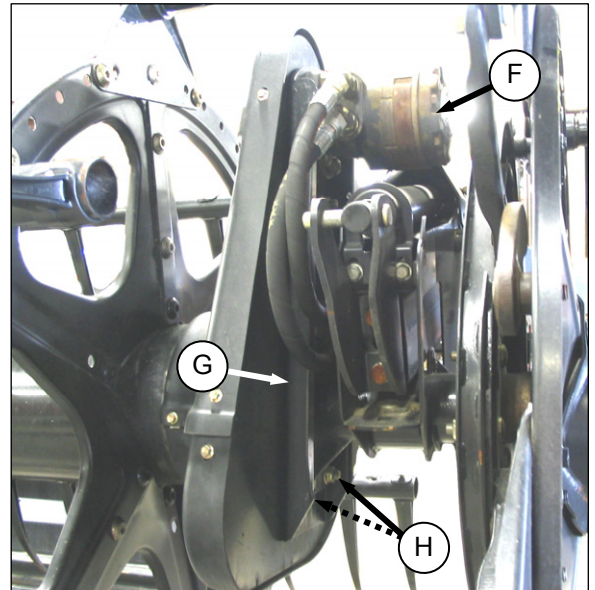

- d. Slide the motor (F) and motor mount (G) until the tension on the chain is such that hand force deflects the chain 1/8 inch (3 mm) at mid-span.
- e. Tighten nuts (H) and recheck tension.
- f. Reinstall drive covers.



## SECTION 10. MAINTENANCE AND SERVICING

### 10.14.6 REEL DRIVE CHAIN - D50

#### 10.14.6.1 Tension Adjustment



#### DANGER

To avoid bodily injury from fall of raised reel, always engage reel props before going under raised reel for any reason.

- Lower header, raise reel and engage reel props.

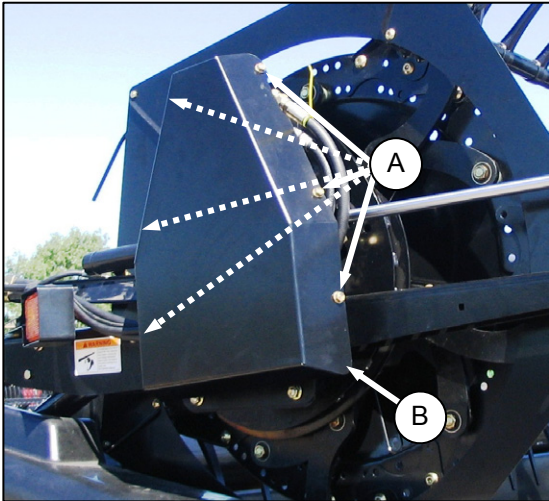

- Remove six screws (A) and remove cover (B).

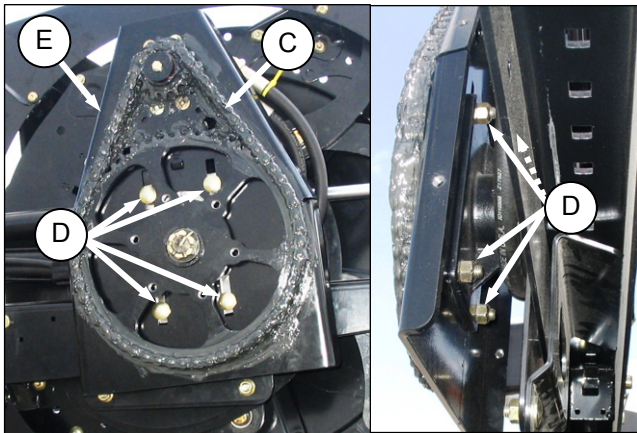

- The tension on the chain (C) should be such that hand force deflects the chain 1/8 inch (3 mm) at mid-span.
- To adjust the tension, loosen four bolts (D).
- Slide the motor and motor mount (E) until the required tension is achieved.
- Tighten bolts (D) to 75 ft·lbf (102 N·m).
- Re-install drive cover.

#### 10.14.6.2 Removal - Drive Chain



#### DANGER

To avoid bodily injury from fall of raised reel, always engage reel props before going under raised reel for any reason.

- Remove reel drive cover. Refer to previous section.
- Loosen drive chain (C) by loosening bolts (D) and sliding motor and motor mount (E) down towards reel shaft.
- Remove chain.

#### 10.14.6.3 Installation - Drive Chain

- Position chain (C) around sprockets as shown.
- Slide the motor and motor mount (E) until the tension on the chain (F) is such that hand force deflects the chain 1/8 in. (3 mm) at mid-span.
- Tighten nuts (D) and recheck tension.
- Reinstall drive cover.

## SECTION 10. MAINTENANCE AND SERVICING

### 10.14.7 REEL DRIVE SPROCKET - D60, FD70



#### CAUTION

To avoid bodily injury from fall of raised reel, always engage reel props before going under raised reel for any reason.

#### 10.14.7.1 Removal - Drive Sprocket

- Remove reel drive cover(s). Refer to Section 10.14.5 Reel Drive Chain - D60, FD70.

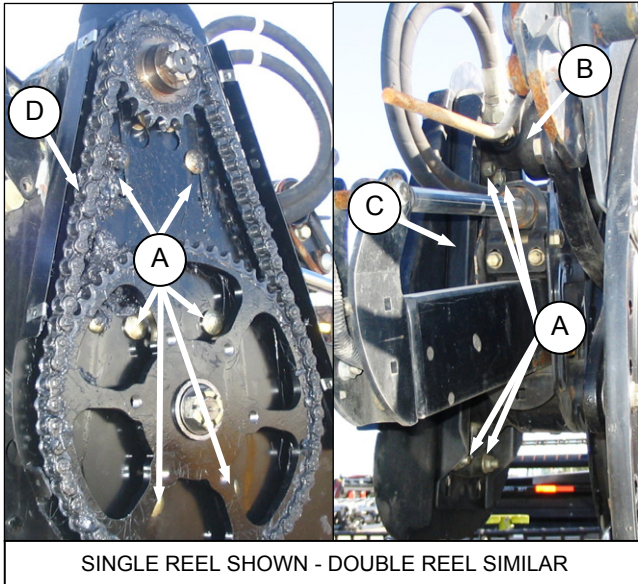

SINGLE REEL SHOWN - DOUBLE REEL SIMILAR

- Loosen six bolts (A) on motor mount.
- Slide the motor (B) and motor mount (C) downward until chain (D) is loose.

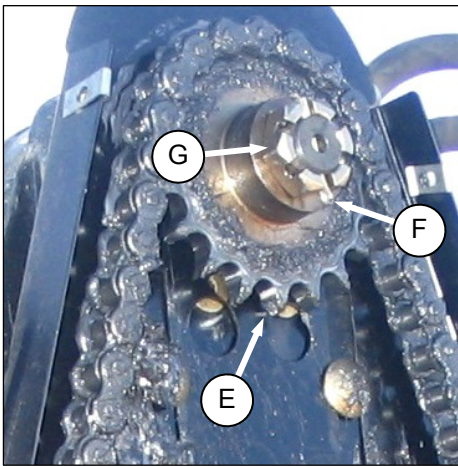

- Slip chain off drive sprocket (E).
- Remove cotter pin (F) and slotted nut (G).
- Remove sprocket (E).

#### IMPORTANT

Do not use pry bar and/or hammer to remove sprocket. This will damage the motor. Use a puller if sprocket does not come off by hand.

#### 10.14.7.2 Installation - Drive Sprocket

Refer to illustrations opposite.

- Align keyway in sprocket (E) with key in shaft and slide new sprocket onto shaft.
- Install slotted nut (G) and torque to 10 - 20 in·lbf (1.1 - 2.2 N·m).
- Install cotter pin (F). Tighten nut to next slot if required.
- Slip chain (D) over drive sprocket and tighten chain.
- Slide the motor (B) and motor mount (C) until the required tension is achieved. The tension on the chain (D) should be such that hand force deflects the chain 1/8 inch (3 mm) at mid-span.
- Tighten bolts (A) to 75 ft·lbf (102 N·m).
- Reinstall drive cover(s). Refer to Section 10.14.5 Reel Drive Chain - D60, FD70.

## SECTION 10. MAINTENANCE AND SERVICING

### 10.14.8 REEL DRIVE SPROCKET - D50



#### CAUTION

To avoid bodily injury from fall of raised reel, always engage reel props before going under raised reel for any reason.

#### 10.14.8.1 Removal - Drive Sprocket

- a. Lower header, raise reel and engage reel props.

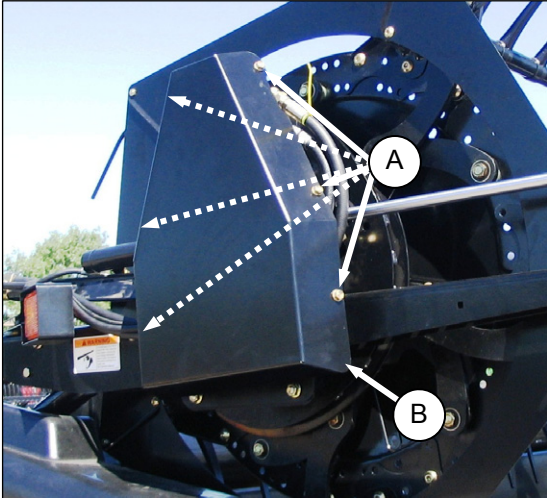

- b. Remove six screws (A) and remove cover (B).

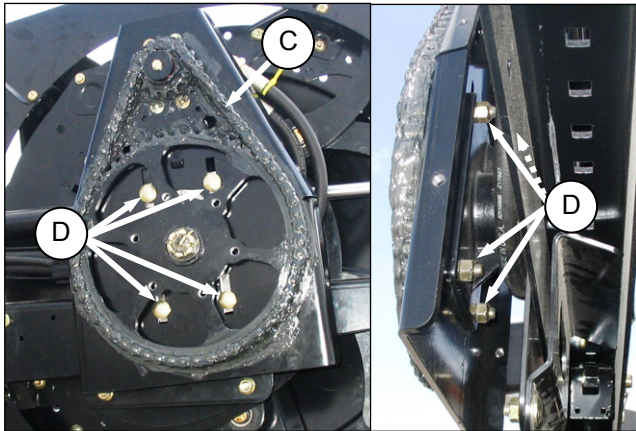

- c. Loosen drive chain (C) by loosening bolts (D) and sliding motor and motor mount (E) down towards reel shaft.

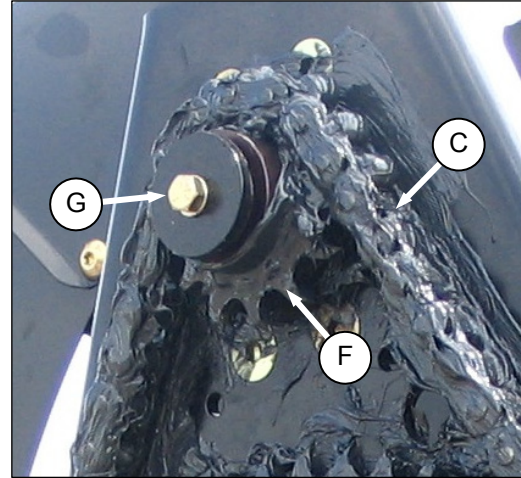

- d. Slip chain (C) off drive sprocket (F).
- e. Remove bolt (G), lock-washer, and flat washer.
- f. Remove sprocket (F).

#### IMPORTANT

Do not use pry bar and/or hammer to remove sprocket. This will damage the motor. Use a puller if sprocket does not come off by hand.

#### 10.14.8.2 Installation - Drive Sprocket

Refer to illustrations above and opposite.

- a. Align keyway in sprocket with key in shaft and slide new sprocket onto shaft as shown.
- b. Install bolt (G), flat washer, and lock-washer. Torque to 18 ft-lbf (24 N·m).
- c. Slip chain (C) over drive sprocket and tighten chain.
- d. Slide the motor and motor mount (E) until the required tension is achieved. The tension on the chain (C) should be such that hand force deflects the chain 1/8 inch (3 mm) at mid-span.
- e. Tighten bolts (D) to 75 ft-lbf (102 N·m).
- f. Reinstall drive cover.



## SECTION 10. MAINTENANCE AND SERVICING

### 10.14.9 REEL DRIVE U-JOINT - D60, FD70 ONLY



#### CAUTION

To avoid bodily injury from fall of raised reel, always engage reel props before going under raised reel for any reason.

#### 10.14.9.1 Removal - U-Joint

- Lower header, raise reel and engage reel props.
- Remove reel drive cover. Refer to Section 10.14.5 Reel Drive Chain - D60, FD70.
- Support inboard end of right reel with a front end loader and nylon slings (or equivalent set-up).

#### IMPORTANT

To avoid damaging or denting center tube, support reel as close as possible to the end disc.

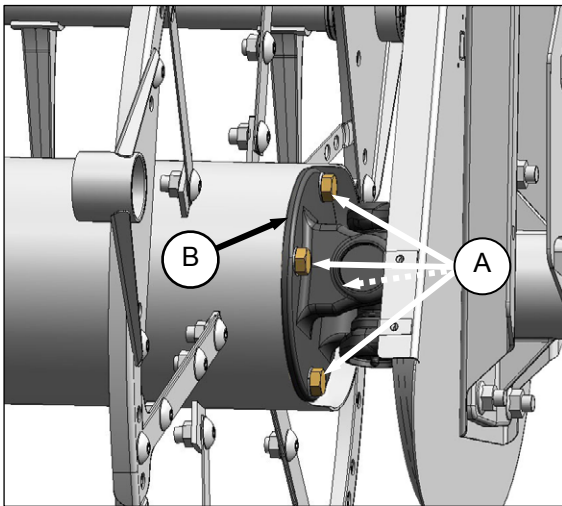

- Remove four bolts (A) attaching reel tube to U-joint (B).

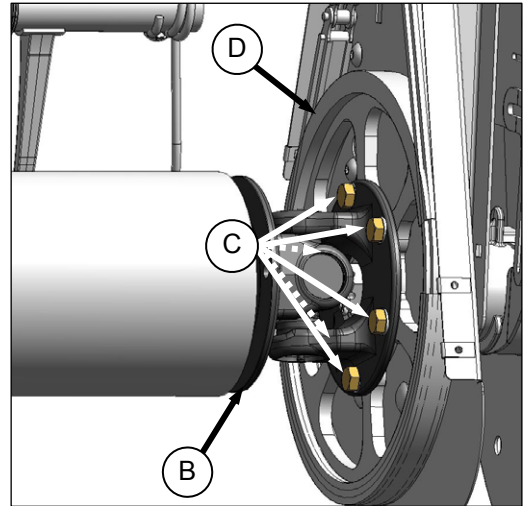

- Remove six bolts (C) attaching U-joint (B) to driven sprocket (D).
- Remove U-joint.

#### NOTE

*Right hand reel may need to be moved sideways for U-joint to clear reel tube.*

#### 10.14.9.2 Installation - U-Joint

Refer to illustrations opposite.

- Position U-joint (B) onto driven sprocket (D) as shown and install six bolts (C) and tighten. Do not torque at this time.
- Position RH reel tube against reel drive and engage stub shaft into U-joint pilot hole.
- Rotate reel until holes in end of reel tube and U-joint line up.
- Install four bolts (A) and torque to 70 - 80 ft·lbf (95 - 108 N·m).
- Torque bolts (C) to 70 - 80 ft·lbf (95 - 108 N·m).
- Remove temporary reel support.
- Re-attach reel drive cover. Refer to Section 10.14.5 Reel Drive Chain - D60, FD70.

## SECTION 10. MAINTENANCE AND SERVICING

### 10.14.10 REEL DRIVE MOTOR - D60, FD70



#### DANGER

To avoid bodily injury from fall of raised reel, always engage reel props before going under raised reel for any reason.

#### 10.14.10.1 Removal - Drive Motor

- Lower header, raise reel and engage reel props.
- Remove reel drive cover. Refer to Section 10.14.5 Reel Drive Chain - D60, FD70.

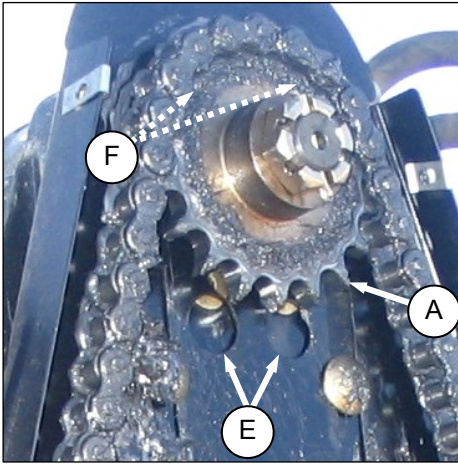

- Loosen chain and remove drive sprocket (A). Refer to Section 10.14.7 Reel Drive Sprocket - D60, FD70.

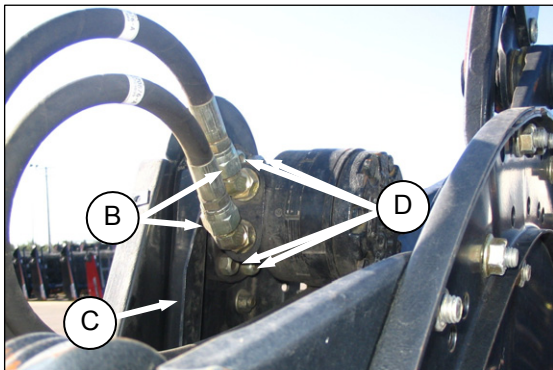

- Disconnect hydraulic lines (B) at motor. Cap or plug open ports and lines.
- Slide motor mount (C) so that attachment bolts (D) are exposed in holes (E) and slots (F) in back plate.
- Remove four nuts and bolts (D) and remove motor.

#### 10.14.10.2 Installation - Drive Motor

Refer to illustrations opposite.

- Position hydraulic motor on motor mount (C) and install four countersunk bolts (D) through holes (E) and slots (F) in chain case into mount. Torque to 75 ft·lbf (102 N·m).
- Re-attach hydraulic lines (B) to motor.
- Install sprocket (A) onto motor shaft and install chain. Refer to Section 10.14.7 Reel Drive Sprocket - D60, FD70.
- Re-attach reel drive cover. Refer to Section 10.14.5 Reel Drive Chain - D60, FD70.

## SECTION 10. MAINTENANCE AND SERVICING

### 10.14.11 REEL DRIVE MOTOR - D50



#### DANGER

To avoid bodily injury from fall of raised reel, always engage reel props before going under raised reel for any reason.

#### 10.14.11.1 Removal - Drive Motor

- Lower header, raise reel and engage reel props.
- Remove reel drive cover. Refer to Section 10.14.6 Reel Drive Chain - D50.

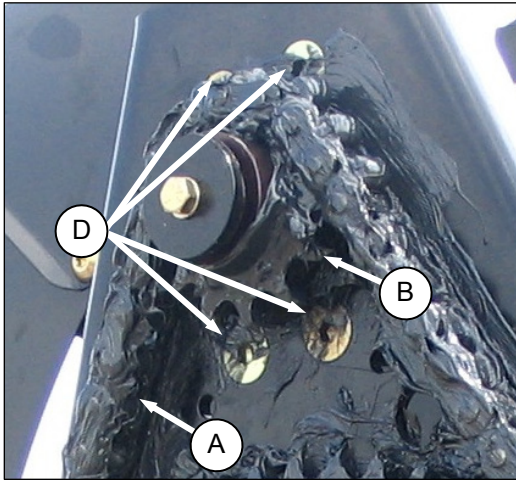

- Loosen chain (A) and remove drive sprocket (B). Refer to Section 10.14.8 Reel Drive Sprocket - D50.

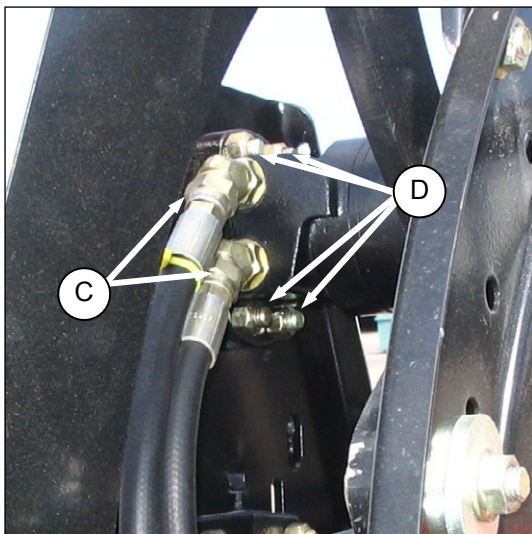

- Disconnect hydraulic lines (C) at motor fittings. Cap or plug open ports and lines.
- Remove the four nuts and bolts (D), and remove motor.

#### 10.14.11.2 Installation - Drive Motor

Refer to illustrations opposite.

- Position hydraulic motor on motor mount and install four countersunk bolts (D). Torque to 75 ft·lbf (102 N·m).
- Re-attach hydraulic lines (C) to motor.
- Install sprocket (B) and chain (A). Refer to Section 10.14.8 Reel Drive Sprocket - D50.
- Re-attach reel drive cover. Refer to Section 10.14.6 Reel Drive Chain - D50.



## SECTION 10. MAINTENANCE AND SERVICING

### 10.14.12 REEL SPEED SENSOR



#### CAUTION

To avoid bodily injury from fall of raised reel, always engage reel props before going under raised reel for any reason.



#### WARNING

Stop combine engine and remove key before making adjustments to machine. A child or even a pet could engage the drive.

Remove reel drive cover for access to the reel speed sensor. Refer to Section 10.14.5 Reel Drive Chain - D60, FD70, or Section 10.14.6 Reel Drive Chain - D50.

#### 10.14.12.1 John Deere

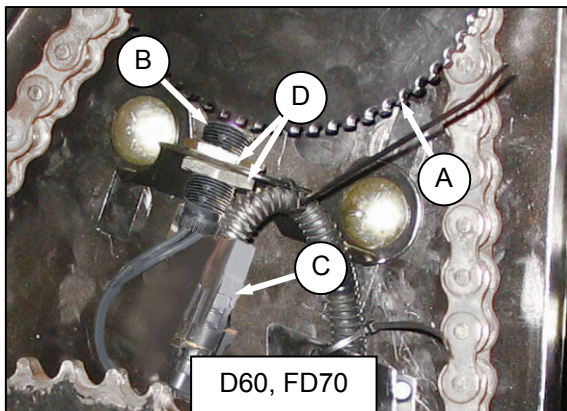
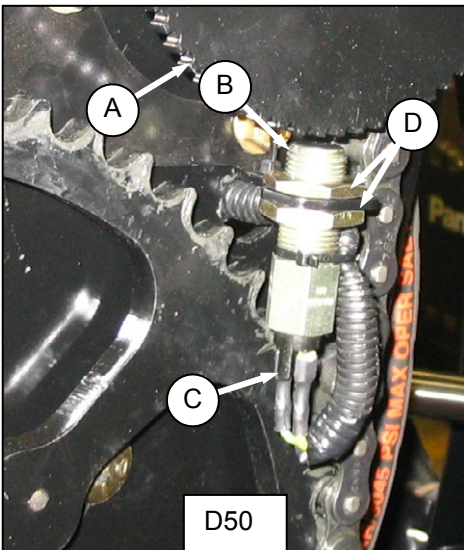

- a. Maintain a 0.12 inch (3 mm) gap between sensor disc (A) and sensor (B). Adjust with nuts (D) as required.

- b. Replace sensor as follows:

1. Disconnect connector (C).
2. Remove nuts (D) and remove sender (B).
3. Remove top nut (D) from new sensor (B) and locate in support.
4. Secure with top nut (D).
5. Adjust gap between sensor disc (A) and sensor (B) to 0.12 in. (3 mm).
6. Connect to harness at (C).

#### IMPORTANT

Ensure sensor electrical harness does not contact chain or sprocket.

#### 10.14.12.2 Lexion 500

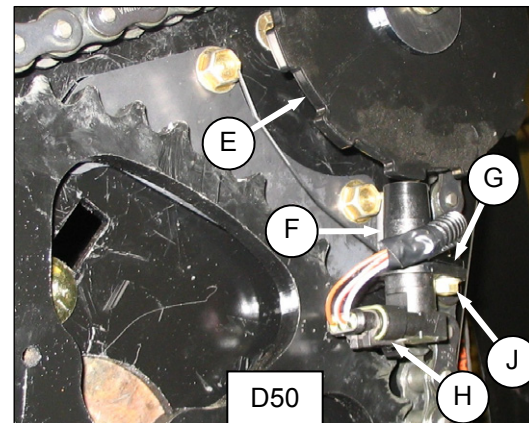
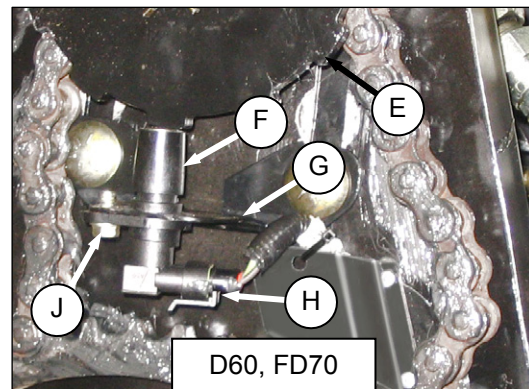

- a. Maintain a 0.12 in. (3 mm) gap between sensor disc (E) and sensor (F). Adjust by bending support (G).
- b. Replace sensor as follows:
1. Disconnect connector (H).
  2. Remove screw (J) attaching and remove sensor (F).
  3. Locate new sensor in support and secure with screw (J).
  4. Adjust gap between sensor disc (E) and sensor (F) to 0.12 in. (3 mm) by bending support (G).
  5. Connect to harness at (H).

## SECTION 10. MAINTENANCE AND SERVICING

### 10.14.12.3 Lexion 400

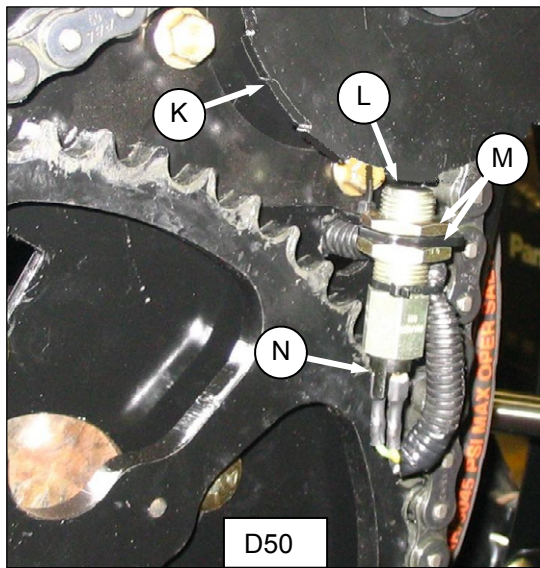
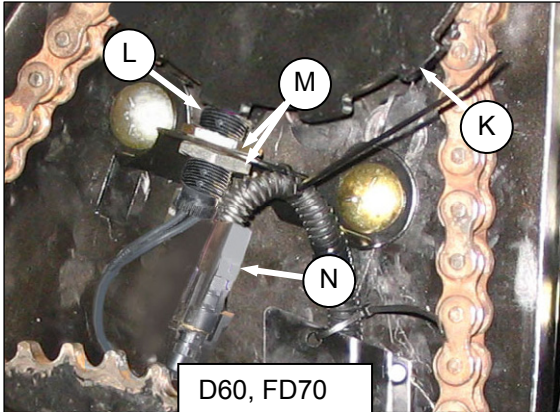

- a. Maintain a 0.12 in. (3 mm) gap between sensor disc (K) and sensor (L). Adjust with nuts (M) as required.
- b. Replace sensor as follows:
  1. Disconnect connector (N).
  2. Remove nuts (M) and remove sender (L).
  3. Remove top nut (M) from new sensor and locate in support.
  4. Secure with top nut (M).
  5. Adjust gap between sensor disc (K) and sensor (L) to 0.12 in. (3 mm) with nuts (M).
  6. Connect to harness at (N).

#### IMPORTANT

Ensure sensor electrical harness does not contact chain or sprocket.

### 10.14.12.4 AGCO

#### D60, FD70 Speed Sensor

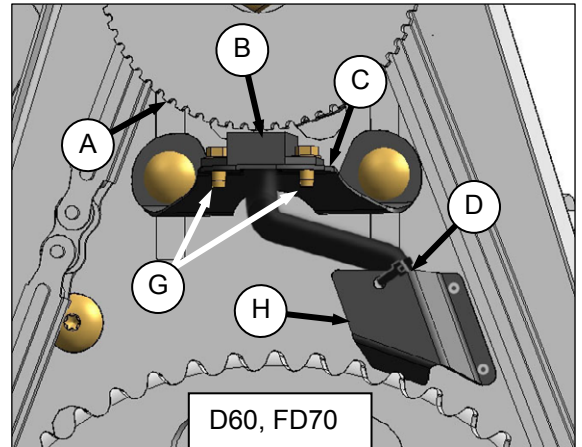

- a. Maintain a 0.02 in. (0.5 mm) gap between sensor disc (A) and sensor (B). Adjust by bending support (C),
- b. Replace sensor as follows:
  1. Cut plastic tie (D) securing harness to cover.

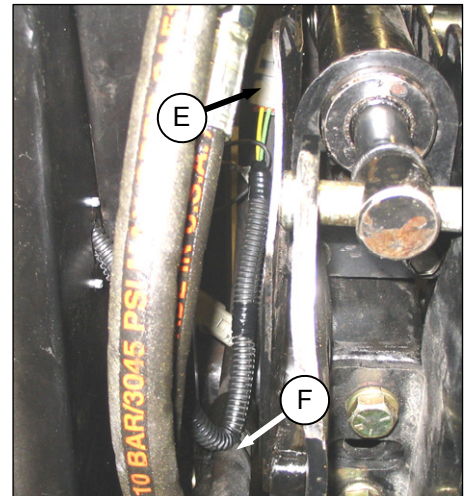

2. Disconnect connector (E) and cut plastic tie (F) securing harness to hose.
3. Remove screws (G), and remove sensor (B) and harness. Bend cover (H) if necessary to remove harness.
4. Feed wire of new sensor behind cover (H) through frame.
5. Locate new sensor in support and attach with two screws (G).
6. Adjust gap between sensor disc (A) and sensor (B) to 0.02 in. (0.5 mm).
7. Connect to harness at (E).
8. Secure harness with plastic ties (D) and (F).



## SECTION 10. MAINTENANCE AND SERVICING

### D50 Speed Sensor

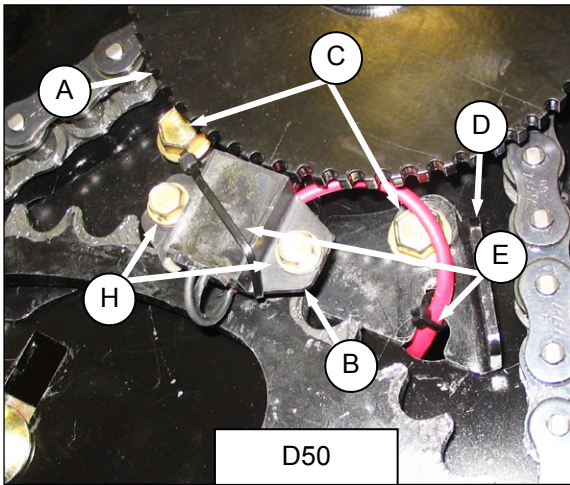

### **IMPORTANT**

Ensure sensor electrical harness does not contact chain or sprocket.

- a. Maintain a 0.02 in. (0.5 mm) gap between sensor disc (A) and sensor (B). Adjust by loosening screws (C) and moving support (D) as required.
- b. Tighten screws (C).
- c. Replace sensor as follows:
  1. Cut plastic ties (E) securing wire to support and sensor.

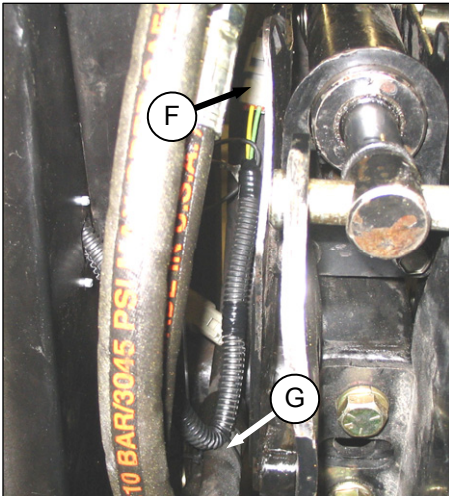

2. Disconnect connector (F) located behind the drive case, and cut plastic tie (G) securing harness to hose.
3. Remove screws (H), and remove sensor (B) and harness.
4. Feed wire of new sensor through hole in case.
5. Locate new sensor in support (D) and attach with two screws (H).
6. Adjust gap between sensor disc (A) and sensor (B) to 0.02 in. (0.5 mm).
7. Connect to harness at (F).
8. Secure harness with plastic ties (E) and (G).



## SECTION 10. MAINTENANCE AND SERVICING

### 10.14.13 REEL TINES

#### IMPORTANT

Keep reel tines in good condition. Straighten or replace as required.

#### 10.14.13.1 Removal - Steel Tines



#### CAUTION

**To avoid bodily injury from fall of raised reel, always engage reel props before going under raised reel for any reason.**

- Lower header, raise reel and engage reel props.
- Remove the tine tube bushings from the applicable tine tube at the center and left discs. Refer to Section 10.14.14 Tine Tube Bushings.

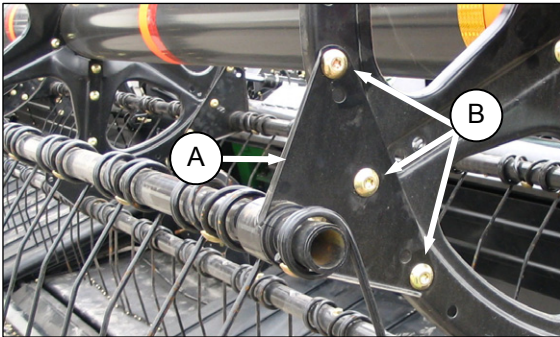

- Temporarily attach reel arms (A) to the reel disc, using the original attachment locations (B).
- Cut the damaged tine(s) so that it can be removed from tube.
- Remove bolts on existing tines and slide tines over to replace the tine cut off in previous step. Remove reel arms (A) from tube as required.

#### 10.14.13.2 Installation - Steel Tines

#### IMPORTANT

Ensure tine tube is supported at all times to prevent damage to the tube or other components.

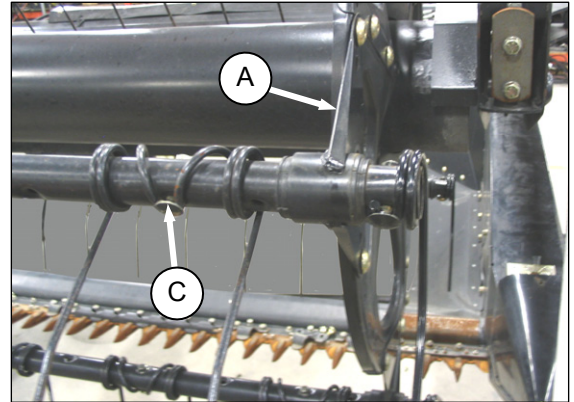

- Slide new tines and reel arms (A) onto end of tube.
- Install tine tube bushings. Refer to Section 10.14.14 Tine Tube Bushings.
- Attach tines to tine bar with bolts and nuts (C).

## SECTION 10. MAINTENANCE AND SERVICING

### 10.14.13.3 Removal - Plastic Fingers

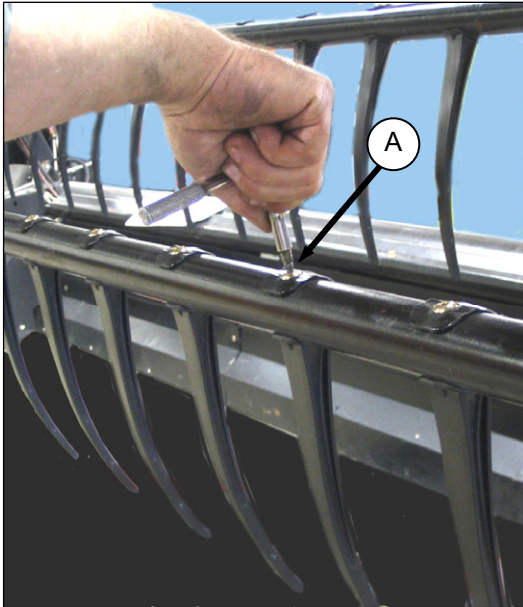

- Remove screw (A) with a Torx-Plus 27 IP socket wrench.
- Push finger top clip back toward reel tube and remove from finger tube.

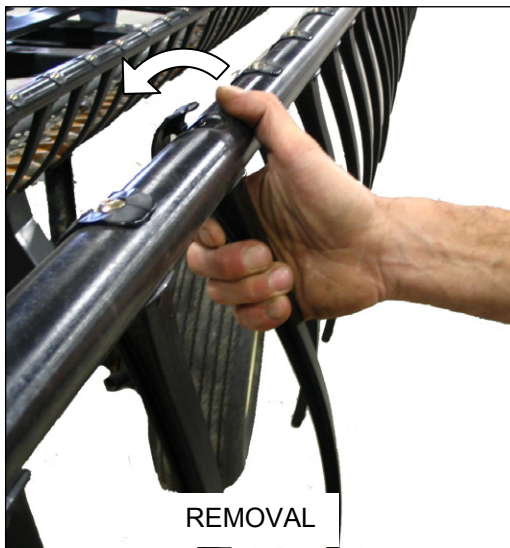

### 10.14.13.4 Installation - Plastic Fingers

- Position finger on rear of finger tube and engage lug at bottom of finger in lower hole in finger tube.



- Gently lift top flange, and rotate finger until lug in top flange engages upper hole in finger tube.

#### **IMPORTANT**

Do not apply force to finger prior to tightening mounting screw. Applying force to finger without screw tightened will break finger or shear off locating pins.

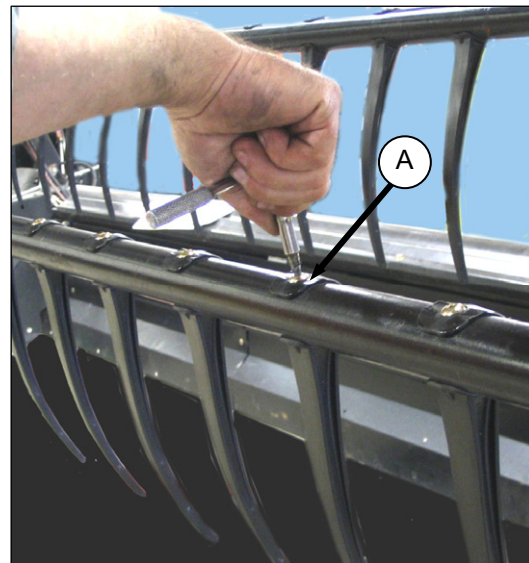

- Install screw (A) and torque to 75 - 80 in-lbf (8.5 - 9.0 N-m) with a Torx-Plus 27 IP socket wrench.



## SECTION 10. MAINTENANCE AND SERVICING

### 10.14.14 TINE TUBE BUSHINGS



#### CAUTION

To avoid bodily injury from fall of raised reel, always engage reel props before going under raised reel for any reason.

Lower header, raise reel fully and engage reel stops.

#### 10.14.14.1 Bushing Removal - 6 and 9-Bat Pick-Up Reels

- a. Remove bushings at center disc and left end disc as follows:

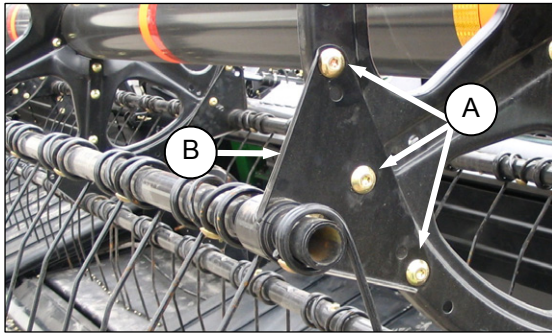

1. Remove bolts (A) securing arm (B) to disc at both locations.

#### IMPORTANT

Ensure tine tube is supported at all times to prevent damage to the tube or other components.

#### IMPORTANT

Note the hole locations in arm and disc and ensure bolts are re-installed at original locations.



2. Release bushing clamps (C) using a small screwdriver to separate the serrations. Pull clamp off tine tube.

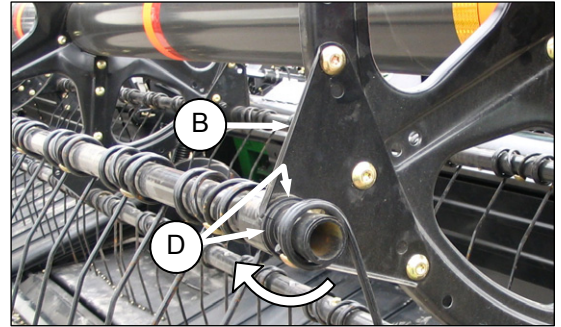

3. Rotate arm (B) clear of disc and slide arm inboard off bushing and remove bushing halves (D). Remove bolt from tine next to arm (or remove plastic finger) if required so that arm can slide off bushing.

- b. Remove cam end bushings as follows:

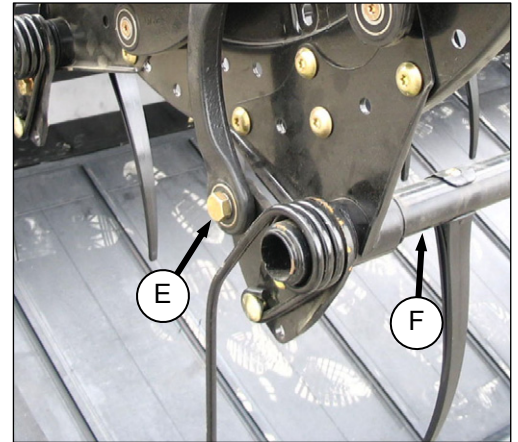

1. Remove bolt (E) at on cam linkage so that tine tube (F) is free to rotate.

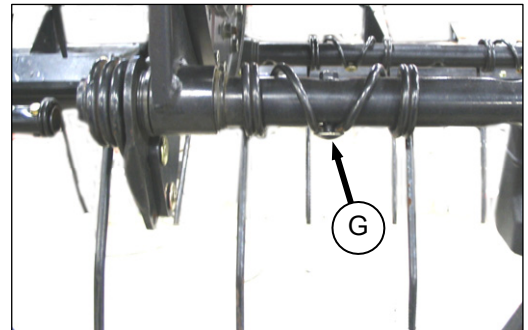

2. If required, remove bolt (G) securing the first tine to the left of the support so that tine is free to move inboard (to the right). If plastic finger is installed, refer to previous section for removal procedure.

*(continued next page)*



## SECTION 10. MAINTENANCE AND SERVICING

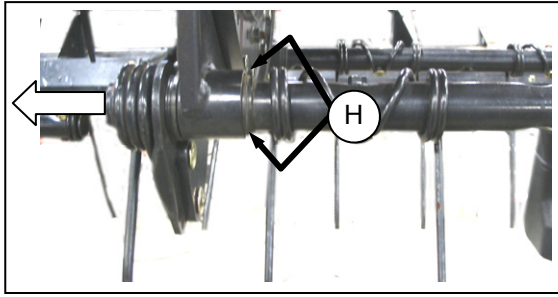

3. Slide tine tube to expose bushing. Remove bushing halves (H).

### 10.14.14.2 Bushing Installation - 6 and 9-Bat Pick-Up Reels

#### IMPORTANT

Ensure tine tube is supported at all times to prevent damage to the tube or other components.

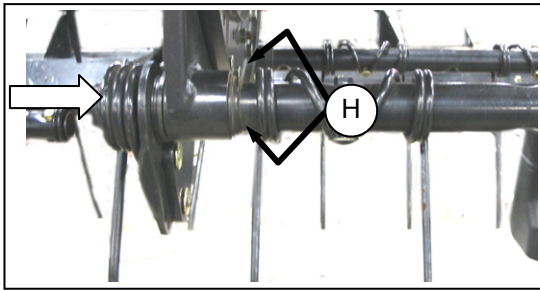

- a. At cam end, position bushing halves (H) on tine tube so that lug in each bushing half locates in hole in tine tube.
- b. Slide tine tube to the left side of header to locate bushings in reel arm.

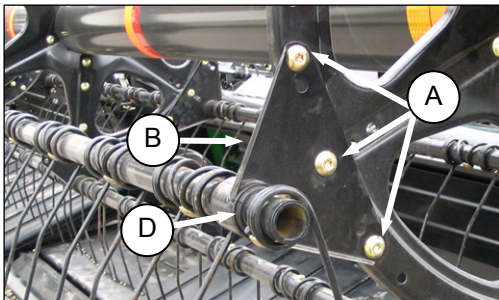

- c. At the center and left side disc, position bushing halves (D) on tine tube so that lug in each bushing half locates in hole in tine tube.
- d. Slide reel arm (B) onto bushing and position against disc at original location.
- e. Install bolts (A) in original holes and tighten.
- f. Reinstall any fingers or tines that were removed.

- g. Install bushing clamps as follows:

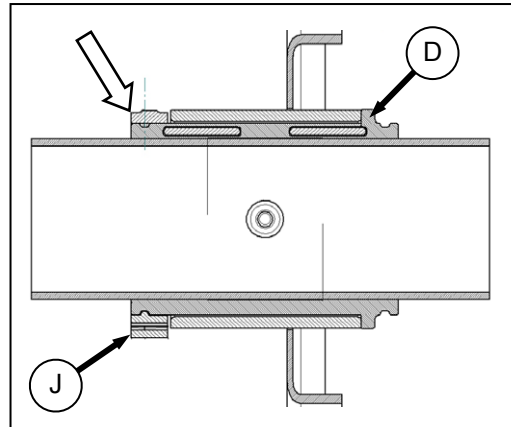

1. Spread clamp (J) and slip over tine tube adjacent to flangeless end of bushing.
2. Locate clamp on bushings (D) so that edges of clamp and bushing are flush when clamp fits into groove on bushing and lock tabs are engaged.

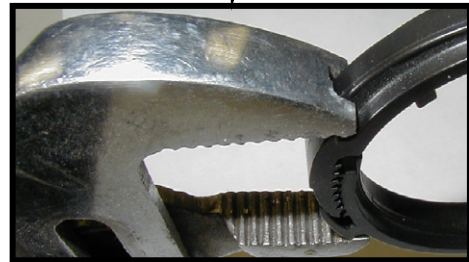
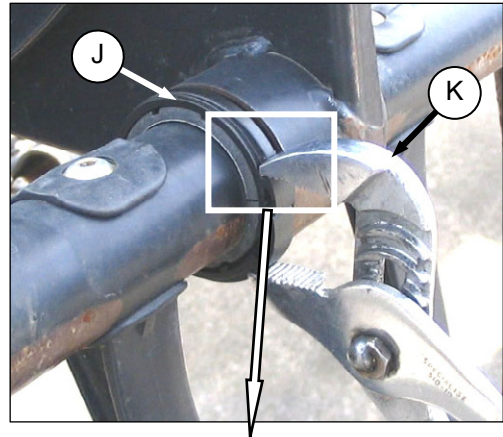

3. Tighten clamp with modified channel lock pliers (K) so that finger pressure will not move clamp.

#### IMPORTANT

Over tightening clamp may result in breakage.

## SECTION 10. MAINTENANCE AND SERVICING

### 10.14.14.3 Bushing Removal - 5-Bat Pick-Up Reels

a. Remove bushings at cam end disc as follows:

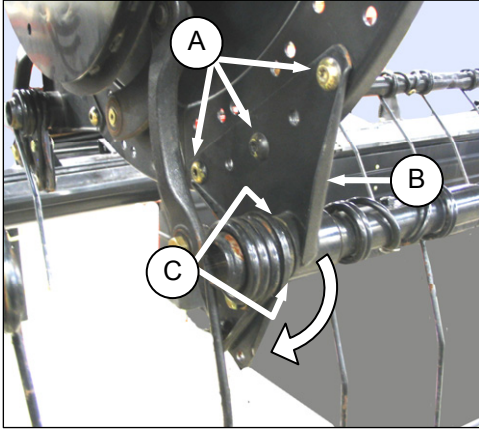

1. Remove bolts (A) securing arm (B) to disc.

**IMPORTANT**

Ensure tine tube is supported at all times to prevent damage to the tube or other components.

**IMPORTANT**

Note the hole locations in arm and disc and ensure bolts are re-installed at original locations.

2. Remove bushing clamp as previously described.
3. Rotate arm (B) clear of disc and slide arm off bushing. Remove bolt from tine next to arm (or remove plastic finger) if required so that arm can slide off bushing.
4. Remove bushing halves (C).

b. Remove bushings at center disc and left end disc as follows:

1. Disconnect reel arm at cam end so that tine tube is free to move. See step a.1.

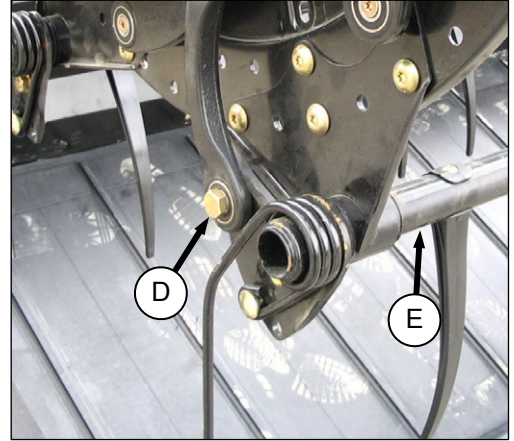

2. Remove bolt (D) at on cam linkage so that tine tube (E) is free to rotate.
3. Slide tine tube outboard to expose bushings.

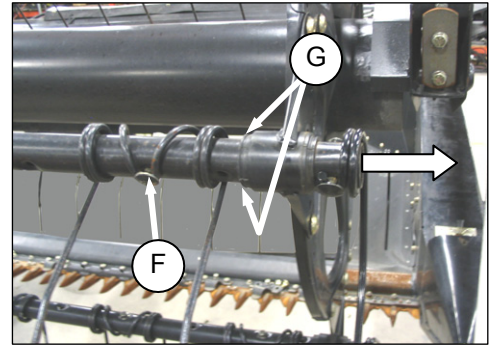

4. Remove bolt (F) from tine (or remove plastic finger) next to arm if required so that tube can slide through arm.
5. Remove bushing halves (G).

*(continued next page)*

## SECTION 10. MAINTENANCE AND SERVICING

### 10.14.14.4 Bushing Installation - 5-Bat Pick-Up Reels

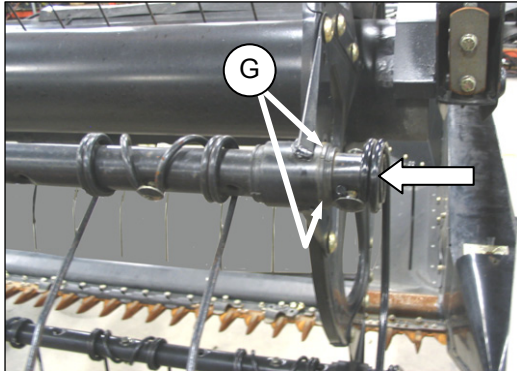

- a. At center disc and left end disc, position bushing halves (G) on tine tube so that lug in each bushing half locates in hole in tine tube.
- b. Slide tine tube inboard (towards cam end) to locate bushing in reel arm.

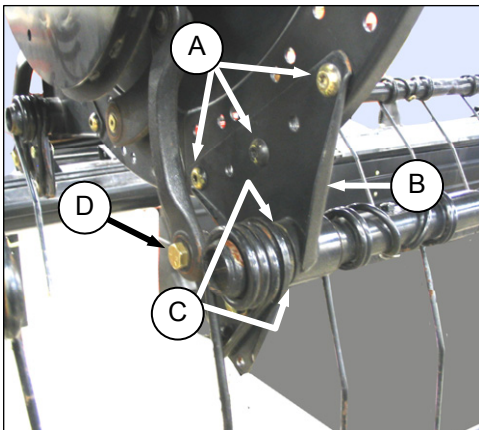

- c. At the cam end disc, position bushing halves (C) on tine tube so that lug in each bushing half locates in hole in tine tube.
- d. Slide reel arm (B) onto bushing and position against disc at original location.
- e. Install bolts (A) in original holes and tighten.
- f. Reinstall any fingers or tines that were removed.
- g. Re-install bolt (D) at on cam linkage.
- h. Install bushing clamps as previously described.



## SECTION 10. MAINTENANCE AND SERVICING

### 10.15 HEADER WING FLOAT



#### CAUTION

To avoid personal injury, before servicing machine or opening drive covers, follow procedures in Section 10.1 PREPARATION FOR SERVICING.

#### 10.15.1 WING FLOAT LOCK ADJUSTMENT

If the cutterbar is not straight when the wings are in LOCK mode, proceed as follows:

- Remove linkage cover. Refer to Section 10.4.2 Linkage Cover (FD70 FLEXDRAPER ONLY).

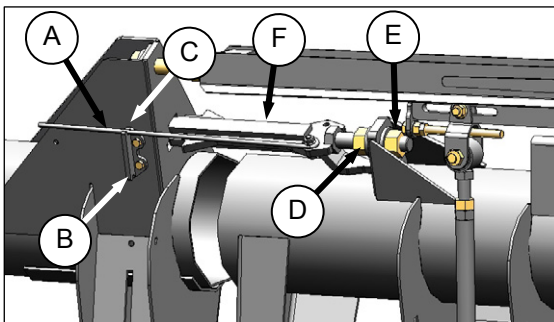

- Unlock the wing float by moving handle (A) to lower UNLOCK position (B).
- Support the header so that the cutterbar is straight by either lowering on level ground or on blocks that are even.
- Lock the wing float by moving handle (A) to the upper LOCK position (C).
- Loosen nut (D) and (E) and adjust so that lock link (F) freely moves out of and into the upper LOCK position.
- Tighten nuts (D) and (E) against spacer to 150 ft·lbf (200 N·m).
- Replace linkage cover.

### 10.15.2 WING BALANCE

If a wing has a tendency to be in a smile or frown position, the wing balance may require adjusting. Check and balance the header wings as follows:



#### WARNING

Stop combine engine and remove key before making adjustments to machine. A child or even a pet could engage the drive.

- Extend the header angle hydraulic cylinder (or mechanical link) 2 - 3 in. (50 - 75 mm) from fully retracted.
- Raise header until cutterbar is 6 - 10 in. (152 - 254 mm) off the ground.
- Stop engine and remove key.

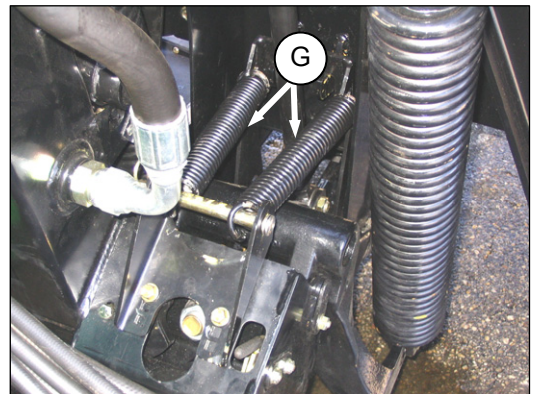

- Check that trim springs (G) are connected to the combine CA20 adapter. Refer to Section 8.2.1 - FD70 FLEXDRAPER/ADAPTER Disassembly if springs are not connected.
- Move transport/stabilizer wheels so that they are supported by header. Refer to Section 9.11.2 Cutting Height.
- Move spring handle (A) to lower position to UNLOCK the wing float.
- Remove linkage cover. Refer to Section 10.4.2 Linkage Cover (FD70 FLEXDRAPER ONLY).

*(continued next page)*

## SECTION 10. MAINTENANCE AND SERVICING

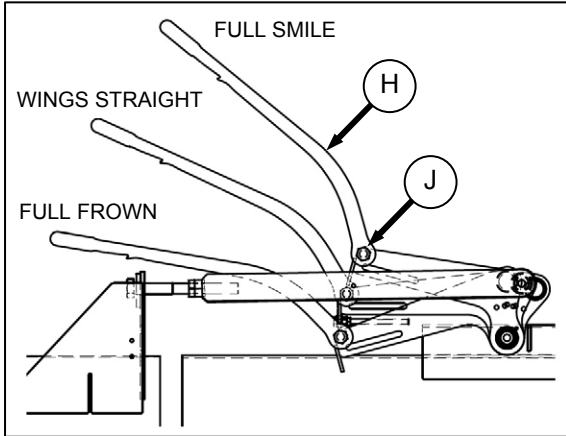

- h. Place wrench (H) (in header leg) on bolt (J).
- i. Move each wing up and down with the wrench (H) to determine tendency of wing to 'smile' or 'frown'.
- j. Balance is set when the same effort is required to move the bellcrank (wing) up or down, or the wing tends to align itself with the center cutterbar.

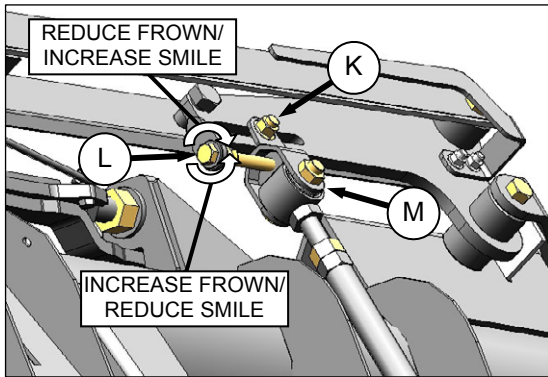

- k. If wing tends to 'smile' (stay up), loosen clamp-bolt (K) and turn draw-bolt (L) counter clockwise to move clevis (M) inboard to reduce the 'smile'.
- l. If wing tends to 'frown' (stay down), loosen clamp-bolt (K) and turn draw-bolt (L) clockwise to move clevis (M) outboard to reduce the 'frown'.
- m. Tighten clamp bolt (K)

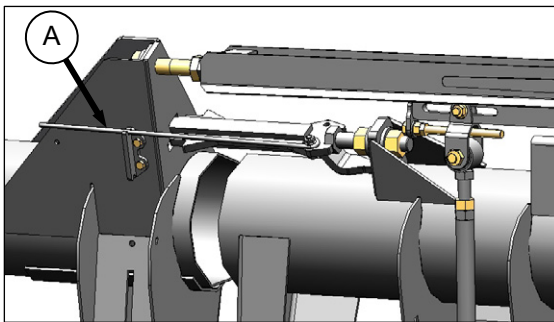

- n. Move spring handle (A) to upper position to LOCK the wing float.

### NOTE

If the cutterbar is not straight when wings are in lock mode, then further adjustments are required. Refer to Section 10.15.1 Wing Float Lock Adjustment.

### NOTE

Decals (N) and (O) are located on the center-link for each wing to indicate adjustments. Refer to illustration below for details.

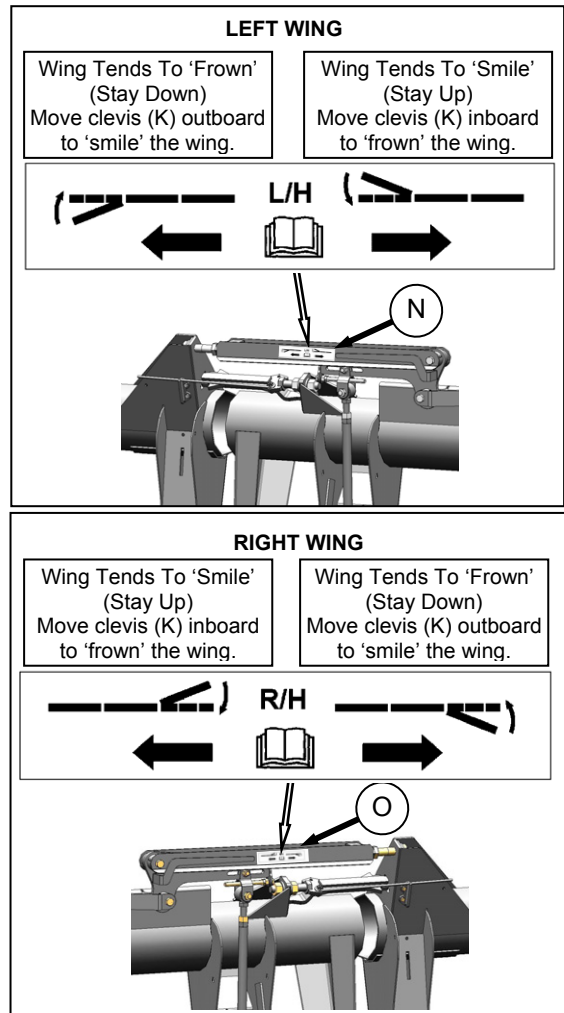

- o. Replace linkage cover and wrench.

### IMPORTANT

Adjustment to the main float may be required to maintain good wing balance when operating in the field. See Section 9.11.3.4 Adjusting Header Float - Cutterbar on Ground.

## SECTION 10. MAINTENANCE AND SERVICING

### 10.15.3 WING LINKAGE ADJUSTMENT



#### WARNING

Stop combine engine and remove key before making adjustments to machine. A child or even a pet could engage the drive.

If the wing vertical movement up or down is not equal, adjust the wing linkage as follows, referring to following illustrations:

- Check that the cutterbar is straight when wings are in LOCK mode.
- Set cutterbar approximately 6 in. (150 mm) off the ground.
- Remove linkage cover. Refer to Section 10.4.2 Linkage Cover (FD70 FLEXDRAPER ONLY).
- With cutterbar straight, check that the following **two conditions exist**:

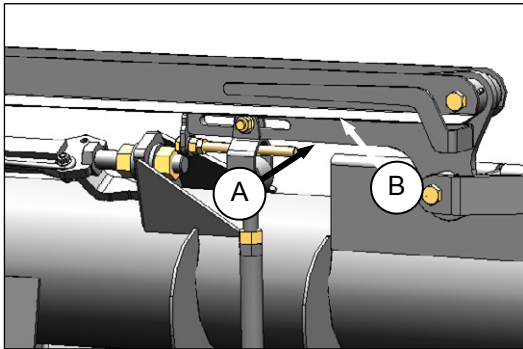

**Condition 1:** Bottom edge of bellcrank (A) is parallel to the bottom edge of the center-link (B).

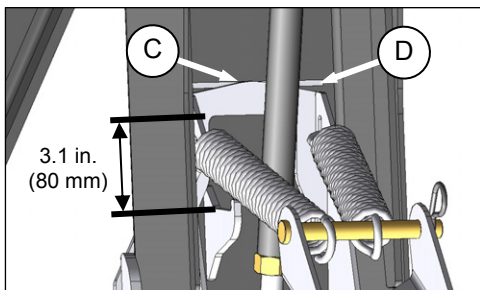

**Condition 2:** The top of the balance link (C) is lined up with the white decal strip (D) within  $\frac{1}{2}$  in. (12 mm).

#### NOTE

If decal is missing, check that dimension is 3.1 +/- 0.5 in. (80 +/- 12 mm).

- If above conditions **do not exist**, perform the following adjustments.

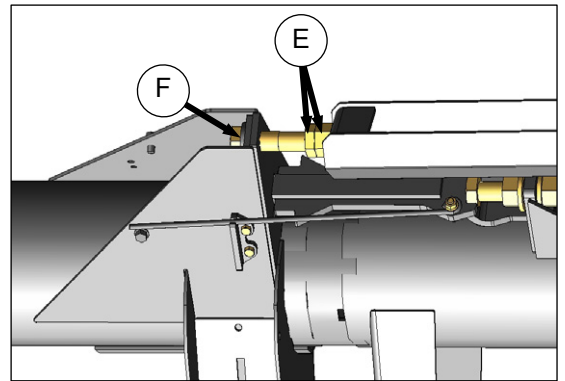

**Condition 1:** Unlock nuts (E) and turn bolt (F) until edges are parallel. Lock nuts (E).

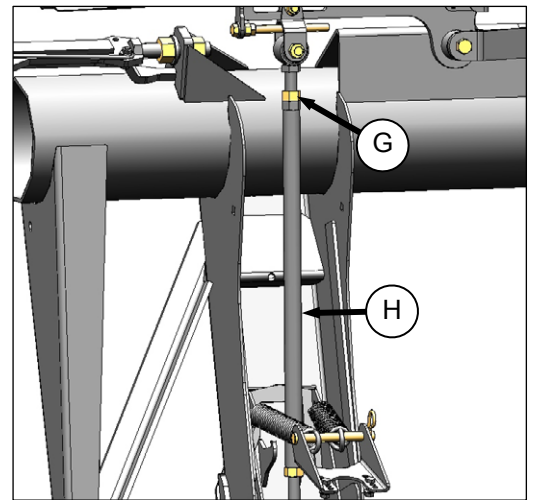

**Condition 2:** Unlock jam-nut (G) and turn compression link (H) until balance link (C) and decal (D) are lined up, or the dimension is met. Lock the nut (G).

#### NOTE

One adjustment may correct both conditions. For example, if the bellcrank lower edge (A) points down, and top of balance link (C) is too low, adjusting the center-link bolt (F) will also improve the alignment of balance link (C) with decal strip (D).

- Replace linkage cover.



## SECTION 10. MAINTENANCE AND SERVICING

### 10.16 TRANSPORT SYSTEM

Optional equipment on 30, 35, 40, and 45 foot headers.

#### 10.16.1 WHEEL BOLT TORQUE

##### IMPORTANT

Whenever a wheel is removed and re-installed, check torque after one hour of operation. Maintain 80 - 90 ft-lbf (110 - 120 N·m) torque.

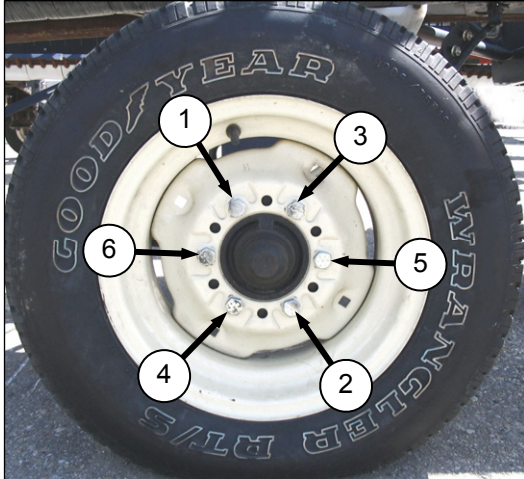

- Check and tighten wheel bolts after the first hour of operation and every 100 hours thereafter. Maintain 80 - 90 ft-lbf (110 - 120 N·m) torque.

##### IMPORTANT

Follow proper bolt tightening sequence shown.

#### 10.16.2 AXLE BOLTS

- Check and tighten axle bolts daily until torque is maintained as shown.

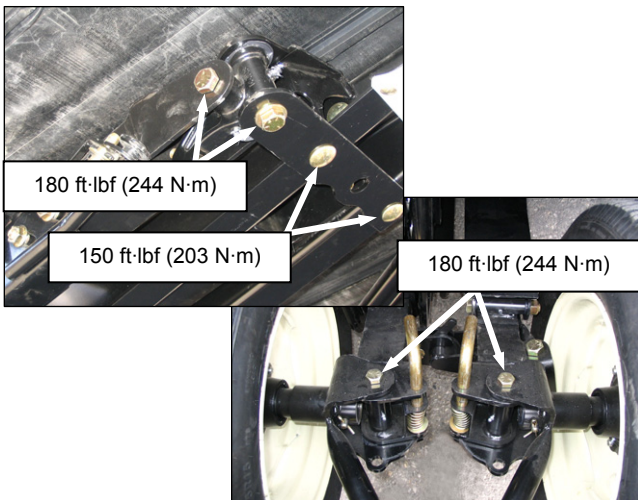

#### 10.16.3 TIRE INFLATION

Check tire pressure daily. Maintain pressures recommended in following table:

YEAR	TIRE	SIZE	PRESSURE
2006 & EARLIER	GOODYEAR WRANGLER RT/S	205-75 R15	40 psi (276 kPa)
2007 to 2009	CARLISLE & TITAN	ST205/75 R15	65 psi (448 kPa)
2010 & LATER	DICO	ST205/75 R15	LR "D" 65 psi (448 kPa)
			LR "E" 80 psi (552 kPa)

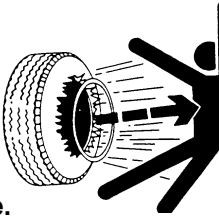

### WARNING

- Service tires safely.
- A tire can explode during inflation and cause serious injury or death. 
- Do not stand over tire. Use a clip-on chuck and extension hose.
- Never increase air pressure beyond pressure specified on tire side wall to seat the bead on the rim.
- Replace the tire if it has a defect.
- Replace a wheel rim, which has cracks, wear or severe rust.
- Never weld a wheel rim.
- Never use force on an inflated or partially inflated tire.
- Make sure the tire is correctly seated before inflating to operating pressure.
- If the tire is not in correct position on the rim, or is too full of air, the tire bead can loosen on one side, causing air to leak at high speed and with great force. An air leak of this nature can thrust the tire in any direction, endangering anyone in the area.
- Make sure all the air is removed from a tire before removing the tire from a rim.
- Do not remove, install or make repairs to a tire on a rim unless you have the proper equipment and experience to perform the job. Take the tire and rim to a qualified tire repair shop.

## SECTION 10. MAINTENANCE AND SERVICING

### 10.17 MAINTENANCE SCHEDULE

The following maintenance schedule is a listing of periodic maintenance procedures, organized by service intervals. Regular maintenance is the best insurance against early wear and untimely breakdowns. Following this schedule will increase machine life.

For detailed instructions, refer to the specific headings in Section 10 MAINTENANCE AND SERVICE. Use the fluids and lubricants specified in Section 10.3.4 Recommended Fluids and Lubricants.

**Service Intervals:** The recommended service intervals are in hours of operation. Where a service interval is given in more than one time frame, e.g. "100 hours or Annually", service the machine at whichever interval is reached first.

#### IMPORTANT

Recommended intervals are for average conditions. Service the machine more often if operated under adverse conditions (severe dust, extra heavy loads, etc.).



#### CAUTION

**Carefully follow safety messages given under Section 10.1 PREPARATION FOR SERVICING, and Section 10.2 RECOMMENDED SAFETY PROCEDURES.**

#### 10.17.1 BREAK-IN INSPECTIONS

BREAK-IN INSPECTIONS		
HOURS	ITEM	CHECK
<b>5 Minutes</b>	Reservoir Hydraulic Oil Level.	Sight Gauge - Lower full, Upper empty.
<b>5</b>	Hardware.	Torque. Refer to Section 10.3.1 Recommended Torques.
	Sickle Drive Belts.	Tension. Refer to Section 10.11.8 Sickle Drive Belts - Non-Timed Drive, and Section 10.11.9 Double Knife Drive Belts - Timed Drive. Periodically check for first 50 hours.
<b>10</b>	Wobble Box Mounting Bolts.	Torque. Refer to Section 10.11.10.1 Mounting Bolts.
<b>50</b>	Adapter Gearbox Oil.	Change. Refer to Section 10.5.5.3 Changing Gearbox Lubricant.
	Adapter Hydraulic Oil Filter.	Change. Refer to Section 10.6.2 Hydraulic Oil Filter.
	Wobble Box Lubricant.	Change. Refer to 10.11.10.6 Changing Oil.

## SECTION 10. MAINTENANCE AND SERVICING

### 10.17.2 INTERVAL MAINTENANCE

<b>INTERVAL</b>	<b>SERVICE</b>	
<b>FIRST USE</b>	Refer To Section 10.17.1 Break-In Inspections (previous page).	
<b>100 HOURS OR ANNUALLY *</b>	<ol style="list-style-type: none"> <li>1. Check Wobble Box Mounting Bolts.</li> <li>2. Check Wobble Box Lubricant Level.</li> <li>3. Check Sickle Drive Belt Tension.</li> <li>4. Check Transport Wheel Bolt Torque (Option).</li> <li>5. Check Reel Tine To Cutterbar Clearance.</li> <li>6. Check Reel Drive Chain Tension.</li> <li>7. Check Auger to Pan and Feed Draper Clearance.</li> <li>8. Check Gearbox Lubricant Level.</li> <li>9. Grease Flex Header Lower Links.</li> </ol>	<ol style="list-style-type: none"> <li>10. Grease Float Spring Tensioners.</li> <li>11. Grease Reel Drive Chain.</li> <li>12. Grease Upper Cross Auger RH Support (Option).</li> <li>13. Grease Auger Bearing.</li> <li>14. Grease Auger Drive Chain.</li> <li>15. Grease Auger Drive-shaft Bearings.</li> <li>16. Grease Anti-Vibration Pivots.</li> <li>17. Grease Float Pivots.</li> <li>18. Lubricate Hydraulic Couplers.</li> <li>19. Check Draper Seal.</li> </ol>
<b>END OF SEASON</b>	Refer To Section 9.10 STORAGE.	
<b>10 HOURS OR DAILY</b>	<ol style="list-style-type: none"> <li>1. Check Hydraulic Hoses and Lines For Leaks.</li> <li>2. Check Stabilizer/Transport Wheels Tire Pressure.</li> <li>3. Check Sickle Sections, Guards, and Hold-Downs.</li> <li>4. Oil Sickle (Except In Sandy Conditions).</li> </ol>	
<b>25 HOURS</b>	<ol style="list-style-type: none"> <li>1. Check Hydraulic Oil Level at Reservoir.</li> <li>2. Grease Sickle Head.</li> </ol>	
<b>50 HOURS</b>	<ol style="list-style-type: none"> <li>1. Grease Sickle Drive Shaft Bearings (Double Knife).</li> <li>2. Grease Driveline and Driveline Universals.</li> <li>3. Grease Draper Roller Bearings.</li> </ol>	
<b>250 HOURS OR ANNUALLY *</b>	<ol style="list-style-type: none"> <li>1. Grease Transport Axle Pivot Bushings (Option).</li> <li>2. Grease Split Reel U-Joint.</li> <li>3. Grease Flex Header Bellcrank Linkage.</li> <li>4. Grease Upper Cross Auger Center Support (30 ft. and Up - Option).</li> <li>5. Grease Auger Pivots.</li> <li>6. Change Hydraulic Oil Filter.</li> <li>7. Check Draper Seal.</li> </ol>	
<b>500 HOURS OR ANNUALLY*</b>	<ol style="list-style-type: none"> <li>1. Grease Transport/Stabilizer Wheel Hub Bearings.</li> <li>2. Grease Reel Shaft Bearings.</li> <li>3. Check Draper Seal.</li> </ol>	
<b>1000 HOURS OR 3 YEARS</b>	<ol style="list-style-type: none"> <li>1. Change Wobble Box Lubricant.</li> </ol>	
<b>1500 HOURS OR 3 YEARS</b>	<ol style="list-style-type: none"> <li>1. Change Hydraulic Oil.</li> <li>2. Change Gearbox Lubricant.</li> </ol>	

**\* IT IS RECOMMENDED THAT ANNUAL MAINTENANCE BE DONE PRIOR TO START OF OPERATING SEASON.**



## SECTION 10. MAINTENANCE AND SERVICING

### 10.17.3 Maintenance Record

MAINTENANCE RECORD	ACTION:	✓ - Check	⬇ - Lubricate	▲ - Change																	
	Hour Meter Reading																				
	Date																				
	Serviced By																				
	<b>FIRST USE</b>	Refer To Section 10.17.1 Break-In Inspections.																			
	<b>100 HOURS OR ANNUALLY</b>																				
✓	Auger to Pan and Feed Draper Clearance																				
✓	Draper Seal																				
✓	Gearbox Lubricant Level																				
✓	Reel Drive Chain Tension																				
✓	Reel Tine/Cutterbar Clearance																				
✓	Sickle Drive Belt Tension																				
✓	Wheel Bolt Torque																				
✓	Wobble Box Lubricant Level																				
✓	Wobble Box Mounting Bolts																				
⬇	Anti-Vibration Pivots																				
⬇	Auger Bearing																				
⬇	Auger Drive Chain																				
⬇	Auger Drive-Shaft Bearings																				
⬇	Flex Header Lower Linkage																				
⬇	Float Pivots																				
⬇	Float Spring Tensioners																				
⬇	Hydraulic Couplers																				
⬇	Reel Drive Chain																				
⬇	Upper Cross Auger RH Support																				
	<b>END OF SEASON</b>	Refer To Section 9.10 STORAGE.																			
	<b>10 HOURS OR DAILY</b>	<b>NOTE: A RECORD OF DAILY MAINTENANCE IS NOT NORMALLY REQUIRED BUT IS AT THE OWNER/OPERATOR'S DISCRETION.</b>																			
✓	Hydraulic Hoses and Lines																				
✓	Sickle Assembly																				
✓	Tire Pressure																				
⬇	Sections, Guards, Hold-downs																				
	<b>25 HOURS</b>																				
✓	Hydraulic Oil Level at Reservoir																				
⬇	Sickle Head(s)																				
	<b>50 HOURS</b>																				
⬇	Draper Roller Bearings																				
⬇	Driveline and Driveline Universals																				
⬇	Sickle Drive Shaft Bearings (DK)																				
▲	Wobble Box Oil - First 50 Hours Only																				

*(continued next page)*



## SECTION 11. TROUBLESHOOTING

### 11 TROUBLESHOOTING

#### 11.1 CROP LOSS AT CUTTERBAR

SYMPTOM	PROBLEM	SOLUTION	SECTION
<b>Does Not Pick Up Down Crop.</b>	Cutterbar too high.	Lower cutterbar.	9.11.2
	Header angle too flat.	Steepen header angle.	9.11.4
	Reel too high.	Lower reel.	9.11.9
	Reel too far back.	Move reel forward.	9.11.10
	Ground speed too fast for reel speed.	Reduce ground speed or increase reel speed.	9.11.6 & 9.11.5
	Reel fingers not lifting crop sufficiently.	Increase finger pitch aggressiveness.	9.11.11
Install lifter guards.		*	
<b>Heads Shattering Or Breaking Off.</b>	Reel speed too fast.	Reduce reel speed.	9.11.5
	Reel too low.	Raise reel.	9.11.9
	Ground speed too fast.	Reduce ground speed.	9.11.6
	Crop too ripe.	Operate at night when humidity is higher.	---
<b>Cut Grain Falling Ahead Of Cutterbar.</b>	Ground speed too slow.	Increase ground speed.	9.11.6
	Reel speed too slow.	Increase reel speed.	9.11.5
	Reel too high.	Lower reel.	9.11.9
	Cutterbar too high.	Lower cutterbar.	9.11.2
	Reel too far forward.	Move reel back on arms.	9.11.10
	Cutting at speeds over 6 mph (10 km/h) with high-torque (10 tooth) reel drive sprocket.	Replace with high speed (19 tooth) reel drive sprocket.	10.14.7
	Worn or broken sickle components.	Replace.	10.11
<b>Strips Of Uncut Material.</b>	Crowding uncut crop.	Allow enough room for crop to be fed to cutterbar.	---
	Broken sickle sections.	Replace.	10.11.1
<b>Excessive Bouncing At Normal Field Speed.</b>	Float set too light.	Adjust header float.	9.11.3
<b>Divider Rod Running Down Standing Crop.</b>	Divider rods too long.	Remove divider rod.	9.11.12

\* See your MacDon dealer.

\*\* Refer to Combine Operator's Manual.

\*\*\* Refer to Draper Header Technical Manual



## SECTION 11. TROUBLESHOOTING

SYMPTOM	PROBLEM	SOLUTION	SECTION
<b>Bushy or Tangled Crop Flows Over Divider Rod, Builds Up On Endsheets.</b>	Divider rods providing insufficient separation.	Install long divider rods or floating dividers.	9.11.12
<b>Crop Not Being Cut At Ends.</b>	Reel not "frowning" or not centered in header.	Adjust reel "frown" or reel horizontal position.	9.11.10 & 10.14.3
	Sickle hold-downs not adjusted properly.	Adjust hold-downs so sickle works freely, but still keep sections from lifting off guards.	10.11.7
	Sickle sections or guards are worn or broken.	Replace all worn and broken cutting parts.	10.11
	Header is not level.	Level header.	9.14
	Reel fingers not lifting crop properly ahead of sickle.	Adjust reel position/finger pitch.	9.11.10 & 9.11.11
	Divider runs down thick crop at ends, preventing proper feeding due to material bridging the cutter guards.	Replace 3 or 4 end guards with stub guards.	*, 10.11.6 & 10.11.7 & 12.7

### 11.2 CUTTING ACTION AND SICKLE COMPONENTS

SYMPTOM	PROBLEM	SOLUTION	SECTION
<b>Ragged Or Uneven Cutting Of Crop.</b>	Sickle hold-downs not adjusted properly.	Adjust hold-downs.	10.11.7
	Sickle sections or guards are worn or broken.	Replace all worn and broken cutting parts.	10.11
	Sickle is not operating at recommended speed.	Check engine speed of combine.	**
	Ground speed too fast for reel speed.	Reduce ground speed or increase reel speed.	9.11.6 & 9.11.5
	Reel fingers not lifting crop properly ahead of sickle.	Adjust reel position/finger pitch.	9.11.10 & 9.11.11
	Cutterbar too high.	Lower cutting height.	9.11.2
	Header angle too flat.	Steepen header angle.	9.11.4
	Bent sickle, causing binding of cutting parts.	Straighten a bent sickle. Align guards.	10.11.6
	Cutting edge of guards not close enough, or parallel to sickle sections.	Align guards.	

\* See your MacDon dealer.

\*\* Refer to Combine Operator's Manual.

\*\*\* Refer to Draper Header Technical Manual

## SECTION 11. TROUBLESHOOTING

SYMPTOM	PROBLEM	SOLUTION	SECTION
<b>Ragged Or Uneven Cutting Of Crop. (Continued).</b>	Tangled/tough to cut crop.	Install stub guards.	*, 10.11.6 & 10.11.7 & 12.7
	Reel too far back.	Move reel forward.	9.11.10
	Loose sickle drive belt.	Adjust drive belt tension.	10.11.8 & 10.11.9
<b>Sickle Plugging.</b>	Reel too high or too far forward.	Lower reel or move reel rearward.	9.11.9 & 9.11.10
	Ground speed too slow.	Increase ground speed.	9.11.6
	Loose sickle drive belt.	Adjust drive belt tension.	10.11.8 & 10.11.9
	Improper sickle hold-down adjustment.	Adjust hold-down.	10.11.7
	Dull or broken sickle sections.	Replace sickle section.	10.11.1
	Bent or broken guards.	Align or replace guards.	10.11.6
	Reel fingers not lifting crop properly ahead of sickle.	Adjust reel position/finger pitch.	9.11.10 & 9.11.11
	Steel pick-up fingers contacting sickle.	Increase reel clearance to cutterbar, or adjust "frown".	10.14.1 & 10.14.2 & 10.14.3
	Main float too heavy.	Adjust springs for lighter float.	9.11.3
	Mud or dirt build-up on cutterbar.	Raise cutterbar by lowering skid shoes.	9.11.2.2
		Install cut-out sections.	*
		Flatten header angle.	9.11.4
	Sickle is not operating at recommended speed.	Check engine speed of combine.	*
<b>Excessive Header Vibration.</b>	Sickle hold-downs not adjusted properly.	Adjust hold-downs.	10.11.7
	Sickles on double knife drive not timed.	Adjust sickle timing.	10.11.9.3
	Sickle not operating at recommended speed.	Check engine speed of combine.	*
	Excessive sickle wear.	Replace sickle.	10.11.2 & 10.11.4
	Loose or worn sickle head pin or drive arm.	Tighten or replace parts.	10.11.3 & 10.11.10

\* See your MacDon dealer.

\*\* Refer to Combine Operator's Manual.

\*\*\* Refer to Draper Header Technical Manual

## SECTION 11. TROUBLESHOOTING

SYMPTOM	PROBLEM	SOLUTION	SECTION
<b>Excessive Vibration Of Adapter And Header.</b>	Vibration dampers not installed (D50 and D60 Harvest Header).	Install vibration dampers.	10.10
	Vibration dampers worn.	Replace rubber in dampers.	10.10.1
	Incorrect knife speed.	Adjust knife speed.	9.11.8
	Driveline U-joints worn.	Replace U-joints.	***
	Bent cutterbar.	Straighten cutterbar.	*
<b>Excessive Breakage Of Sickle Sections Or Guards.</b>	Sickle hold-downs not adjusted properly.	Adjust hold-downs.	10.11.7
	Cutterbar operating too low in stony conditions.	Raise cutterbar, using skid shoes.	9.11.2.2
	Main float is set too heavy.	Adjust float springs for lighter float.	9.11.3
	Bent or broken guard.	Straighten or replace.	10.11.6
	Header angle too steep.	Flatten header angle.	9.11.4
<b>Sickle Back Breakage.</b>	Bent or broken guard.	Straighten or replace.	10.11.6
	Worn sickle head pin.	Replace.	10.11.3
	Dull sickle.	Replace.	10.11.2 & 10.11.4

### 11.3 REEL DELIVERY

SYMPTOM	PROBLEM	SOLUTION	SECTION
<b>Reel Not Releasing Material in Normal Standing Crop.</b>	Reel speed too fast.	Reduce reel speed.	9.11.5
	Reel too low.	Raise reel.	9.11.9
	Reel tines too aggressive.	Reduce cam setting.	9.11.11
	Reel too far back.	Move reel forward.	9.11.10
<b>Reel Not Releasing Material in Lodged and Standing Crop (Reel Fully Lowered).</b>	Reel tines too aggressive for standing crop.	Reduce cam setting (1 or 2).	9.11.11
<b>Wrapping On Reel End.</b>	Reel tines too aggressive.	Reduce cam setting.	
	Reel too low.	Raise reel.	9.11.9
	Reel speed too fast.	Reduce reel speed.	9.11.5
	Crop conditions.	Install optional endshields.	* & 12.13
	Reel not centered in header.	Center reel in header.	10.14.4



\* See your MacDon dealer.

\*\* Refer to Combine Operator's Manual.

\*\*\* Refer to Draper Header Technical Manual



## SECTION 11. TROUBLESHOOTING

SYMPTOM	PROBLEM	SOLUTION	SECTION
<b>Reel Releases Crop Too Quickly.</b>	Reel tines not aggressive enough.	Increase cam setting.	9.11.11
	Reel too far forward.	Move reel back.	9.11.10
<b>Reel Will Not Lift.</b>	Reel lift couplers are incompatible or defective.	Change quick coupler.	---
<b>Reel Will Not Turn.</b>	Quick couplers not properly connected.	Connect couplers.	**
	Reel drive chain disconnected.	Connect chain.	10.14.5 & 10.14.6
<b>Reel Motion Uneven Under No Load.</b>	Excessive slack in reel drive chain.	Tighten chain.	10.14.5 & 10.14.6
<b>Reel Motion Is Uneven or stalls In heavy crops.</b>	Reel speed too fast.	Reduce reel speed.	9.11.5
	Reel fingers not aggressive enough.	Move to a more aggressive finger pitch notch.	9.11.11
	Reel too low.	Raise reel.	9.11.9
	Relief valve on combine (not on combine adapter) has low relief pressure setting.	Increase relief pressure to manufacturer's recommendations.	**
<b>Reel Motion Is Uneven Or Stalls In Heavy Crop.</b>	Low oil reservoir level on combine. (NOTE: Sometimes more than one reservoir.)	Fill to proper level.	
	Relief valve malfunction.	Replace relief valve.	
<b>Plastic Fingers Cut at Tip.</b> 	Insufficient reel to cutterbar clearance.	Increase clearance on D50, D60.	10.14.1
		Increase clearance on FD70.	10.14.2
<b>Plastic Fingers Bent Rearward at Tip.</b> 	Reel digging into ground with reel speed slower than ground speed.	Raise header.	9.11.2
		Decrease header tilt.	9.11.4
		Move reel aft.	9.11.10
<b>Plastic fingers Bent Forward at Tip (opposite of above).</b> 	Reel digging into ground with reel speed faster than ground speed.	Raise header.	9.11.2
		Decrease header tilt.	9.11.4
		Move reel aft.	9.11.10

\* See your MacDon dealer.

\*\* Refer to Combine Operator's Manual.

\*\*\* Refer to Draper Header Technical Manual

## SECTION 11. TROUBLESHOOTING

### 11.4 HEADER AND DRAPERS

SYMPTOM	PROBLEM	SOLUTION	SECTION
Header Lift Insufficient.	Low relief pressure.	Increase relief pressure.	**
Insufficient Side Draper Speed.	Speed control set too low.	Increase control setting.	9.11.7
	Relief pressure too low.	Increase relief pressure to recommended setting.	***
	Combine header drive too slow.	Adjust to correct speed for combine model.	**
	Worn out gear pump.	Replace pump.	***
	Pressure compensator (V7) set too low.	Adjust to increase setting.	**
Draper Will Not Drive.	Drapers are loose.	Tighten drapers.	10.13.1
	Drive or idler roller wrapped with material.	Loosen draper and clean rollers.	
	Slat or connector bar jammed by frame or material.	Loosen draper and clear obstruction.	
	Roller bearing seized.	Replace.	10.13.4
	Low hydraulic oil.	Fill reservoir to full level.	10.6.1.2
	Incorrect relief setting at flow control valve.	Adjust relief setting.	***
Draper Stalling.	Material not feeding evenly off sickle.	Lower reel.	9.11.9
		Install stub guards.	*, 10.11.6 & 10.11.7 & 12.7
Adapter Auger Back-Feeds.	Auger set too high.	Check reversing mechanism inside auger.	***
		Lower auger.	10.9.1
	John Deere: Feeder chain running too slow.	Run feeder chain at high speed.	**
	John Deere: Equipped with feeder chain with 4 pitches per bar.	Replace with 6 pitch per bar feeder chain, or remove every other bar.	
Case: Stone retarding drum installed, or smooth feeder chain bars installed.	Install standard drum or fill slots in stone retarding drum, or install serrated feed chain bars.		
Hesitation In Flow Of Bulky Crop.	Header angle too flat.	Steepen header angle.	9.11.4
	Material overload on drapers.	Increase side draper speed.	9.11.7
		Install upper cross auger.	*
		Add flighting extensions.	7.1.2
Material accumulation at auger ends.	Install stripper bars.	7.1.3	

\* See your MacDon dealer.

\*\* Refer to Combine Operator's Manual.

\*\*\* Refer to Draper Header Technical Manual

## SECTION 11. TROUBLESHOOTING

SYMPTOM	PROBLEM	SOLUTION	SECTION
<b>Hesitation In Flow Of Bulky Crop (Continued).</b>	Case: Stone retarder blocks interfering with crop flow.	Adjust blocks to minimum height.	**
	Side drapers running too fast, piling material in center of feeder draper.	Reduce header side draper speed.	9.11.7
	Feed chain drum too low.	Move drum to corn position.	**
<b>Adapter Auger Wraps Crop.</b>	Crop susceptible to wrapping (flax).	Add fighting extensions or stripper bars.	7.1.2 7.1.3
	Auger speed too fast.	Install slow down kit.	*
<b>Combine Feeder Drum Wraps Crop.</b>	Crop susceptible to wrapping (flax).	Add stripper bars.	7.1.3
<b>Crop Backs Up Or Hesitates On Feed Draper.</b>	Feed draper stalling.	Clean debris from poly pan.	---
		Check feed draper tension.	10.12.1
		Replace roller bearing(s).	***
		Check feed draper motor.	
	Heavy crop plugging between adapter auger and feed draper.	Check auger clearance.	10.9.1
		See also "Adapter Auger back-feeds on opposite page.	---
Auger speed too low.	Install auger speed up kit.	*	
<b>Crop Back Feeds On Center Feed Draper.</b>	Excessive clearance from auger to drive roller.	Lower auger.	10.9.1
	Auger speed too slow.	Install auger speed-up kit.	*
<b>Side Drapers Back-Feed.</b>	Side drapers running too slow in heavy crop.	Increase side draper speed.	9.11.7
<b>Crop Is Thrown Across Opening And Under Opposite Side Draper.</b>	Side drapers running too fast in light crop.	Reduce side draper speed	
	Excessive overlap of feeder draper.	Center side draper drive rollers over feed draper side deflectors.	***
<b>Crop Feeding Into Feeder House At Sides More Than At Center.</b>	Auger not delivering crop properly.	Add fighting extensions.	7.1.2
		Add stripper bars.	7.1.3
		Remove auger outer tines.	10.9.4
		Install auger speed-up kit.	*
<b>Crop Feeding Into Feeder House At Center More Than At Sides.</b>	Auger not delivering crop properly.	Add auger outer tines.	10.9.4
		Remove fighting extensions.	7.1.2
		Remove auger stripper bars	7.1.3

\* See your MacDon dealer.

\*\* Refer to Combine Operator's Manual.

\*\*\* Refer to Draper Header Technical Manual



## SECTION 11. TROUBLESHOOTING

SYMPTOM	PROBLEM	SOLUTION	SECTION
<b>Crop Getting Stuffed In Gap Between Cutout in Endsheets and Knife Head.</b>	Crop heads leaning away from knife head hole in endsheet.	Add shields, except in damp/sticky soils,	9.13
<b>Material Accumulates Inside Or Under Front Edge Of Draper.</b>	Deck height improperly adjusted.	Adjust deck height.	10.13.5
<b>Material Wrapping At Upper Cross Auger Beater Bars.</b>	Crop conditions do not require beater bars.	Remove beater bars.	9.17
<b>Material Accumulating On End Deflectors And Releasing In Bunches.</b>	End deflectors too wide.	Manual Deck Shift Only – Trim deflector or replace with narrow deflector (172381).	9.12.1

### 11.5 FD70 FLEXDRAPER

SYMPTOM	PROBLEM	SOLUTION	SECTION
<b>Cutterbar Pushes Dirt Across Entire Length.</b>	Header height too low.	Raise header height with float optimizer control.	**
	Main float locked.	Unlock main float.	9.11.3
	Main float set too heavy.	Adjust main float.	
	Header angle too steep.	Adjust header to optimum angle.	9.11.4
<b>Stubble Longer At Center Than At Dividers, Or Cutterbar Pushes Dirt At Dividers, Not At Center.</b>	Too much weight on wings.	Adjust wing balance, transferring weight to center section.	10.15.2
	Too much weight on center of header.	Adjust wing balance, transferring weight to wings.	
<b>Pushing Dirt At Combine Adapter Lower Beam.</b>	Combine face plate incorrectly installed.	Remove adapter and check combine faceplate.	**
	Header angle too flat.	Increase header angle.	9.11.4
	Main float too light, header legs do not rest on stops.	Adjust to heavier float.	9.11.3
<b>Wings Will Not Frown Without Excessive Down Force.</b>	Wings set too light.	Adjust wing balance.	10.15.2
<b>Wing Float Assembly Binding.</b>	Main float locked out.	Disengage adapter float lockout.	9.11.3
	Main float set too heavy.	Adjust adapter springs to lighter float.	

\* See your MacDon dealer.

\*\* Refer to Combine Operator's Manual.

\*\*\* Refer to Draper Header Technical Manual

## SECTION 11. TROUBLESHOOTING

SYMPTOM	PROBLEM	SOLUTION	SECTION
<b>Reel Contacts Endsheets, Especially In Smile Condition.</b>	Reel not centered in header.	Center reel in header.	10.14.4
	Loose reel arm brace.	Center reel in header and tighten brace.	
<b>Reel Fingers Being Cut At Header Hinge Points In Frown Condition.</b>	Reel clearance inadequate.	Adjust reel clearance to cutterbar.	10.14.2
		Adjust reel frown at finger tubes.	10.14.3

### 11.6 CUTTING EDIBLE BEANS

SYMPTOM	PROBLEM	SOLUTION	SECTION
<b>Plants Being Stripped, and Complete Or Partial Plants Left Behind.</b>	Header being carried off ground.	Lower header to ground and run on skid shoes and/or cutterbar.	9.11.2.2
	Float set too light - rides on high spots and does not get back down soon enough.	Set float for: 100-150 lbf - dry ground; 50-100 lbf - wet ground.	9.11.3
	Reel being operated too high.	Fully retract reel cylinders.	9.11.9
	Reel too high with cylinders fully retracted.	Adjust reel height.	10.14.1 & 10.14.2
	Finger pitch not aggressive enough.	Adjust finger pitch.	9.11.11
	Reel too far back on reel support arms.	Move reel forward until the fingertips skim the soil surface with header on ground and center-link properly adjusted.	9.11.10
	Header angle too shallow.	Lengthen center-link. If cutting on ground, header angle can be increased by fully retracting lift cylinders.	9.11.4
	Reel too slow.	Adjust reel speed to be marginally faster than ground speed.	9.11.5
	Ground speed too fast.	Lower ground speed.	9.11.6
	Header skid shoes adjusted too low.	Raise skid shoes to maximum up position.	9.11.2.1
	Dirt packs on bottom of cutterbar and raises cutterbar off the ground.	Install plastic wear strips on bottom of cutterbar and skid shoes.	*

\* See your MacDon dealer.

\*\* Refer to Combine Operator's Manual.

\*\*\* Refer to Draper Header Technical Manual

## SECTION 11. TROUBLESHOOTING

SYMPTOM	PROBLEM	SOLUTION	SECTION
<b>Plants Being Stripped, and Complete Or Partial Plants Left Behind.</b>	Dirt packing on bottom of cutterbar with poly wear strips on cutterbar and raises cutterbar off the ground.	Ground too wet. Allow soil to dry.	---
		Manually clean the bottom of cutterbar when accumulation gets unacceptable.	
	Plastic wear strip for cutterbar has been installed over top of steel wear plates.	Remove steel cutterbar wear plates when installing the plastic wear strips for cutterbar	
	Header not level.	Level Header.	9.14
	Worn/damaged knife sections.	Replace sections or complete knife.	10.11.1 & 10.11.2 & 10.11.4
	Parts of vines get caught in pointed guard tip. (Occurs more in row-cropped beans that are hilled from cultivating.)	Install stub guard kit.	*, 10.11.6 & 10.11.7 & 12.7
<b>Plant Vines Pinched Between Top Of Draper And Cutterbar.</b>	Cutterbar has filled up with trash with draper to cutterbar gap properly adjusted.	Raise header fully at each end of field or as required and shift decks back and forth to help clean out cutterbar.	---
	Shifting of decks with header raised does not clean out cutterbar debris.	Manually remove debris from cutterbar cavity to prevent damage to drapers.	
<b>Excessive Losses At Dividers.</b>	Divider rod running down crop and shattering pods.	Remove divider rod.	9.11.12
	Vines and plants build up on endsheet.	Install divider rod.	
<b>Crop Accumulating At Guards And Not Moving Rearward Onto Drapers.</b>	Reel finger pitch not aggressive enough.	Increase finger aggressiveness (cam position).	9.11.11
	Reel too high relative to knife.	Re-adjust reel minimum height with cylinders fully retracted.	10.14.1 & 10.14.2
	Reel too far forward of cutterbar C-section.	Reposition reel.	9.11.10
<b>Cutterbar Guards Breaking.</b>	Main float insufficient.	Increase float	9.11.3
	Excessive amount of rocks in field.	Consider installing optional stub guards. Tip: Experiment with a few guards on a section of cutterbar to compare the performance of the two different styles of guards.	*, 10.11.6 & 10.11.7 & 12.7

\* See your MacDon dealer.

\*\* Refer to Combine Operator's Manual.

\*\*\* Refer to Draper Header Technical Manual

## SECTION 11. TROUBLESHOOTING

SYMPTOM	PROBLEM	SOLUTION	SECTION
<b>Cutterbar Pushing Too Much Trash And Dirt.</b>	Header too heavy.	Readjust float to make header lighter.	9.11.3
	Header angle too steep.	Decrease header angle with lift cylinders.	9.11.4
		Shorten the center-link	
	Regular guards push dirt and plug up with trash or plug up with trash and then push dirt.	Install stub guard kit.	*, 10.11.6 & 10.11.7 & 12.7
Improper support for header.	Install center skid shoes on header.	*	
<b>Cutterbar Pushing Too Much Dirt In Certain Locations For Length Of Field.</b>	Tire tracks or row crop ridges caused by seeding or spraying operations.	Cut at angle to ridges or crop rows to allow knife and guards to clean out better.	---
	Rolling land along length of field due to cultivating.	Cut at 90° to undulations, provided knife floats across without digging in.	
<b>Cutterbar Fills Up With Dirt.</b>	Excessive gap between top of front of draper and cutterbar.	Adjust front deck hooks to obtain proper clearance between cutterbar and draper.	10.13.5
		Raise header fully at each end of field or as required and shift decks back and forth to help clean out cutterbar.	---
<b>Reel Shattering Pods.</b>	Reel running too fast.	Reduce reel speed.	9.11.5
	Bean pods are too dry.	Cut at night with heavy dew once pods have softened.	---
	Reel finger pitch not aggressive enough.	Increase finger aggressiveness (cam position).	9.11.11
	Reel too far forward of cutterbar C-section.	Reposition reel.	9.11.10
<b>Reel Carries Over Odd Plants In Same Location.</b>	Reel fingers (steel) bent and hook plants out of the crop flow on drapers.	Straighten fingers (steel).	---
	Dirt accumulation on end of fingers do not let plants slide off fingers over drapers.	Raise reel.	9.11.9
		Adjust reel fore and aft location to move fingers out of the ground.	9.11.10

\* See your MacDon dealer.

\*\* Refer to Combine Operator's Manual.

\*\*\* Refer to Draper Header Technical Manual



## SECTION 11. TROUBLESHOOTING

SYMPTOM	PROBLEM	SOLUTION	SECTION
<b>Reel Carries Over Excessive Amounts Of Plants Or Wads.</b>	Excessive accumulation of crop on drapers (up to height of reel center tube).	Increase draper speed.	9.11.7
	Finger pitch too retarded.	Increase finger pitch.	9.11.11
<b>Reel Wraps Up With Crop.</b>	Reel too low.	Raise reel.	9.11.9
<b>Reel Ends Wrap Up With Crop.</b>	Uncut crop interfering on reel ends.	Add reel endshields.	10.4.1

\* See your MacDon dealer.

\*\* Refer to Combine Operator's Manual.

\*\*\* Refer to Draper Header Technical Manual

## SECTION 12. OPTIONS AND ATTACHMENTS

### 12 OPTIONS AND ATTACHMENTS

See your MacDon Dealer for availability and ordering information.

#### 12.1 AUTO HEADER HEIGHT CONTROLLER

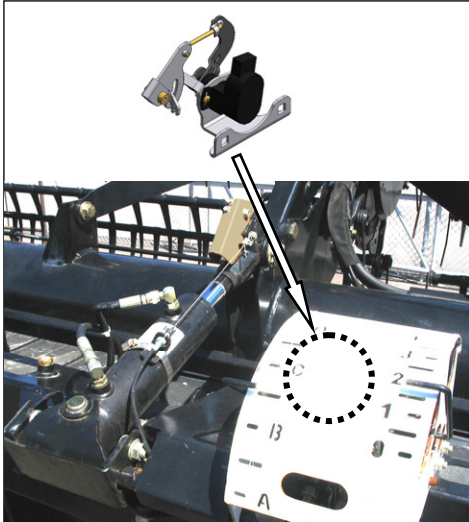

For use in conjunction with Auto Header Height Control option on Case, New Holland, John Deere and AGCO combines, and with the Header Float option on Lexion combines on Model D50 and D60 Harvest Headers. It is standard equipment on the FD70 FlexDraper header.

This attachment includes a potentiometer that sends a signal to the combine to allow maintaining a consistent cutting height and optimum adapter float as the header follows ground contours.

Mounting hardware, electrical harnesses and installation instructions are included.

#### 12.2 KNIFE REVERSING KIT

Available as an attachment for use with combine headers. The reversing kit attaches to the CA20 adapter hydraulics and allows the header knife drive to be reversed which assists in unplugging the knife.

Installation and adjustment instructions are included with the kit.

#### 12.3 FLOAT/ANGLE INDICATOR

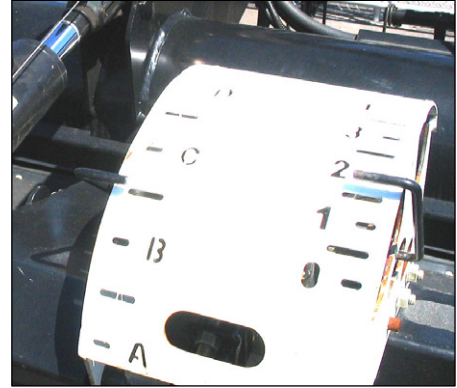

Available as an attachment for use with D50 and D60 Harvest Headers, and standard equipment on FD70 FlexDraper headers.

This attachment indicates to the Operator the float setting and header angle setting with the hydraulic center-link system.

Mounting hardware, electrical harnesses and installation instructions are included.

#### 12.4 HYDRAULIC HEADER TILT



Available as an attachment for use with D50 and D60 Harvest Headers, and standard equipment on FD70 FlexDraper headers.

This system allows changing the header angle from the Operator's console without stopping the machine.

## SECTION 12. OPTIONS AND ATTACHMENTS

### 12.5 CUTTERBAR POLY



Available as an attachment for use with D50 and D60 Harvest Headers, and standard equipment on FD70 FlexDraper headers.

They are recommended for cutting on the ground where the soil adheres to steel.

### 12.6 ADJUSTABLE SKID SHOES WITH POLY COVER

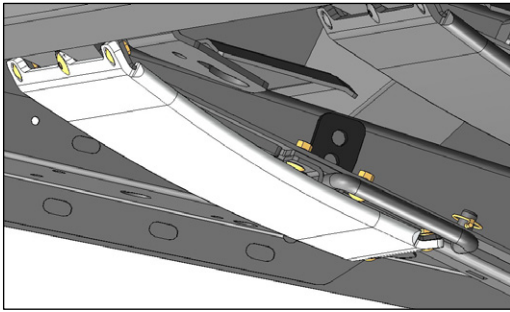

Available as an attachment for use with D50 and D60 Harvest Headers, and standard equipment on FD70 FlexDraper headers.

They are recommended for cutting on the ground.

### 12.7 STUB GUARD CONVERSION KIT

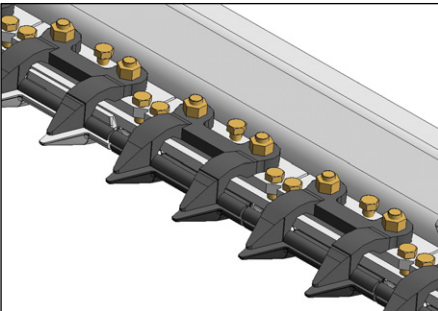

Stub guards, complete with top guides and adjuster shoes are designed to cut tough crops.

Installation and adjustment instructions are included with the kit.

### 12.8 STABILIZER WHEELS

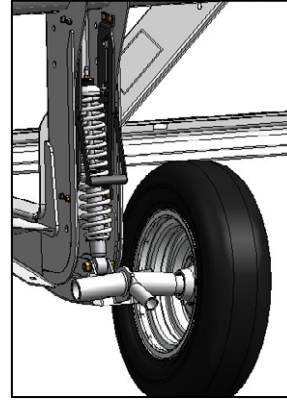

Available as an attachment for use with selected sizes of D50 and D60 Harvest Headers, and FD70 FlexDraper headers.

The stabilizer wheels help stabilize the header in field conditions that would otherwise cause the header to bounce and result in uneven cutting height.

Installation and adjustment instructions are included with the kit.

### 12.9 STABILIZER/TRANSPORT WHEELS



Available as an attachment for use with selected sizes of D50 and D60 Harvest Headers, and FD70 FlexDraper headers.

The stabilizer/transport wheels help stabilize the header in field conditions that would otherwise cause the header to bounce and result in uneven cutting height.

The wheels convert to transport mode to allow the header to be towed behind the combine, or pick-up at slow speed.

## SECTION 12. OPTIONS AND ATTACHMENTS

### 12.10 LODGED CROP REEL FINGER KIT

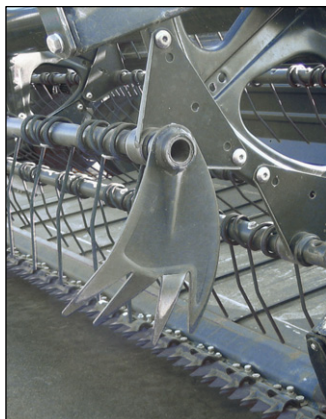

Available as an attachment for use with D50 and D60 Harvest Header, and FD70 FlexDraper headers.

The steel fingers attach to ends of every other tine bar and help in clearing material in heavy hard to cut crops.

Two kits are required for modifying each bar of a 6-bat reel.

Installation and adjustment instructions are included with the kit.

### 12.11 VERTICAL KNIFE MOUNTS

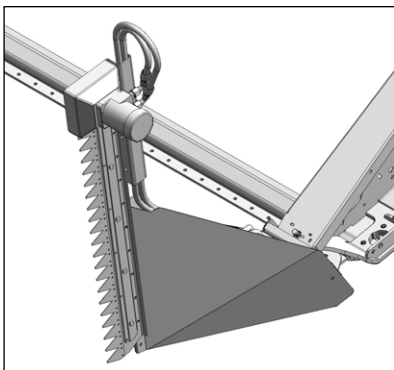

The vertical knife mounts allow installation of vertically oriented sickles onto both ends of D50, D60, and FD70 headers.

The SABRE vertical knife must be obtained from Canadian Agri Technologies. See your MacDon Dealer for further details.

Installation and adjustment instructions are included with the kit.

### 12.12 UPPER CROSS AUGER



Available as an attachment for use with D50 and D60 Harvest Header, and FD70 FlexDraper headers.

The cross auger helps deliver very bulky crops across the header onto the windrow or into the combine.

Installation and adjustment instructions are included with the kit.

### 12.13 REEL ENDSHIELD KIT



Available as an attachment for use with D50 and D60 Harvest Header, and FD70 FlexDraper headers.

The steel shields attach to ends of the reel and help in clearing material in heavy hard to cut crops.

Installation and adjustment instructions are included with the kit.



## SECTION 12. OPTIONS AND ATTACHMENTS

### 12.14 ROCK RETARDER KIT



Available as an attachment for use with D50 and D60 Harvest Header, and FD70 FlexDraper headers.

The rock retarder kit keeps rocks from rolling past the cutterbar and onto the drapers.

Installation and adjustment instructions are included with the kit.

### 12.15 RICE DIVIDER KIT

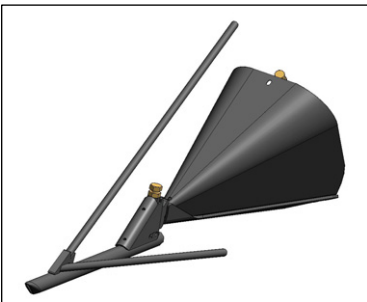

Available as an attachment for use with D50 and D60 Harvest Header, and FD70 FlexDraper headers.

The rice dividers attach to the LH and RH endsheets, and perform the same function in tall and tangled rice crops as standard equipment crop dividers.

Installation and adjustment instructions are included with the kit.

### 12.16 HYDRAULIC REEL FORE-AFT POSITIONER

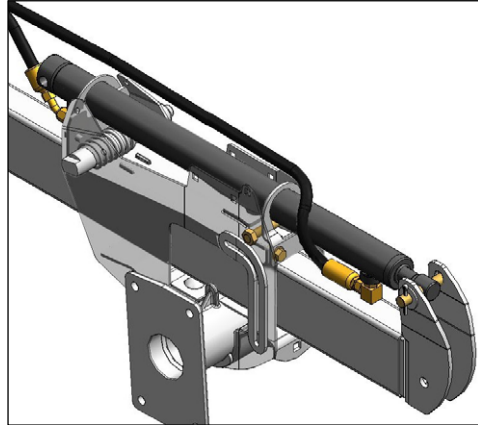

Available for headers that were not factory equipped with the hydraulic reel fore-aft option.

The hydraulic fore-aft option allows an Operator to control the reel fore-aft position from the cab.

Installation and adjustment instructions are included with the kit.

### 12.17 CA20 DELICATE SEED SAVER KIT

It is a kit that encloses the transition area of the feed draper and side draper area near the front of the header and also includes side rubber flaps to close off areas in between the adapter and header.

This kit is NOT RECOMMENDED for use if there are rocks present.

### 12.18 KNIFE HEAD SHIELD

Available as an attachment for use with D50 and D60 Harvest Header, and FD70 FlexDraper headers.

The shields attach to the endsheets and reduce the knife head opening to prevent cut crop from accumulating over the knife head. They are slightly different depending on header size.

- Use MacDon part # 125853 for 25 foot and down.
- Use MacDon part #125538 for 30 foot and up.

## SECTION 13. UNLOADING AND ASSEMBLY

### 13 UNLOADING AND ASSEMBLY

Refer to header specific instruction for the unloading, assembly and set-up procedures that are included with your shipment, according to the following table:

<b>SHIPPING DESTINATION</b>	<b>HEADER DESCRIPTION</b>	<b>INSTRUCTION PART NUMBER</b>
NORTH AMERICA	D50/D60 HARVEST HEADER AND CA20 ADAPTER	169076
	FD70 FLEXDRAPER AND CA20 ADAPTER	169010
EXPORT	D50/D60 HARVEST HEADER AND CA20 ADAPTER	169077
	FD70 FLEXDRAPER AND CA20 ADAPTER	169012

# INDEX

Abbreviations.....	22	adjustments .....	185
Adapter		clearance .....	189
auger removal.....	126	replacement.....	181, 183
components.....	24	roller maintenance .....	186
feed deck removal .....	124	roller seal replacement.....	187
feed draper .....	181	speed .....	99
mounting.....	27	tension .....	183
unplug.....	113	Drive Chain	
Adapter/Header		replacement.....	160
D50, D60 disassembly.....	63	Driveline	
D50, D60 assembly .....	66	guard.....	156
FD70 assembly.....	75	installation.....	156
FD70 disassembly .....	71	removal .....	155
Adjustable Skid Shoes with Poly Cover.....	234	Electrical	
Attachment		lights and wiring .....	155
adapter .....	27	Endshields .....	134
AGCO.....	58	Feed Draper	
Case IH 7010, 8010.....	30	tension .....	181
CAT Lexion.....	48	Flighting Extensions.....	27, 28
John Deere 60, 70 Series.....	40	Float	
John Deere 50 Series.....	44	header.....	92
New Holland CR/CX .....	54	lock .....	92
Attachments.....	233	wing lock - FD70 .....	95
Auger		Float/Angle Indicator.....	233
drive chain adjustment.....	160	Flotation, header	
drive chain lubrication.....	147	linkage adjustment.....	215
flighting .....	27	lock adjustment.....	213
pan clearance .....	159	Gearbox	
speed.....	29	drive chain adjustment.....	158
tine replacement.....	162	main drive .....	147
Auto Header Height Controller.....	233	oil changing.....	147
Bearing, sealed		oil level.....	147
installation.....	131	Greasing.....	138, 139, 140, 141, 142, 143, 144, 145
Bolt Torques .....	129	Ground	
Break-In Inspections.....	217	cutting on .....	91
Break-In Period.....	80	Ground Speed .....	98
CA20 Delicate Seed Saver Kit.....	236	Guards	
Cam		alignment .....	168
adjustment .....	106	pointed .....	168, 169, 171
operation.....	105	replacement.....	168
Center-Link		stub .....	169, 171, 234
disconnect .....	64, 73	Header	
Center-Link Kit.....	27	angle.....	96
Components .....	23	components .....	23
Cover, linkage.....	137	controls .....	82
Crop dividers and rods .....	107	cylinder lockouts .....	82
Cutterbar Poly.....	234	float adjust .....	92
Cutting Height.....	89	float lock.....	92
Deck Height.....	189	levelling.....	112
Deck Repositioning.....	126	set-up.....	85
Detachment		Header Float .....	92
AGCO.....	61	cutterbar on ground.....	95
Case IH 7010, 8010.....	32	normal.....	94
Case 2300, 2500 .....	37	Header/Adapter	
CAT Lexion.....	51	detach/attach .....	63
John Deere 50 Series.....	46	Hydraulic Header Tilt .....	233
John Deere 60, 70 Series.....	42	Hydraulic Oil .....	132
New Holland CR/CX .....	56	Hydraulic Reel Fore Aft Positioner .....	236
Dimensions.....	25	Hydraulics	
Divider Rods.....	107	hoses and lines.....	151
Draper Deflectors .....	110	knife and draper.....	69
replacement.....	110	leaks .....	151
trimming.....	110	oil adding .....	149
Drapers		oil changing.....	150

# INDEX

oil filter.....	151	procedures.....	128
oil level.....	149	signal words.....	7
reservoir.....	149	symbols.....	7
schematics.....	152	Serial Number.....	2
Interval Maintenance.....	218	Servicing.....	
Knife Head Shield.....	111, 236	preparation.....	128
Knife Reversing Kit.....	233	Shields.....	
Knife Speed.....	100	end.....	134
Lift Cylinder Lockouts.....	82	Shut-Down.....	81
Lights.....	155	Sickle.....	
Lodged Crop Reel Finger Kit.....	235	bearing replacement.....	166
Lubricants.....	132	guards.....	168
Lubrication.....	138	hold-downs.....	171
Main Drive Gearbox.....	147	installation.....	167
Maintenance.....		removal.....	166
intervals.....	218	sections.....	165
record.....	219	spare.....	167
schedule.....	217	Sickle Drive Belt.....	
Maintenance and Servicing.....	128	double.....	173
Metric Conversions.....	133	installation.....	172, 176
Oiling.....	146	removal.....	172, 176
Operating Variables.....	89	single.....	172
Operation.....	79	tension.....	172, 173, 175, 176
Options.....	233	timing.....	173
Owner/Operator Responsibilities.....	79	v-belts.....	175
Pre-Season Check.....	80	Sickle, Double.....	
Reel.....		timing.....	177
centering.....	193	Skid Shoes.....	91
chart.....	86	Specifications.....	25
fore-aft position.....	101	Stabilizer Wheels.....	89, 234
height.....	100	Stabilizer/Transport Wheels.....	234
optional sprockets.....	97	Start-Up Check.....	81
props.....	82	Storage.....	84
reel/cutterbar clearance.....		Stripper Bars.....	28
D50, D60.....	190	Stub Guard Conversion Kit.....	234
FD70.....	191	Stub Guards.....	See Guards - stub
speed.....	97	Tine Tube Bushings.....	
speed sensor.....	204	installation.....	210
tine pitch.....	105	replacement.....	209
Reel and Reel Drive.....	190	Tines.....	
Reel Drive.....		auger.....	162
U-Joint replacement.....	201	plastic.....	208
Reel Drive Chain.....		reel.....	207
D60, FD70.....	194	steel.....	207
D50.....	198	Tire inflation.....	216
Reel Drive Motor.....		Top Link.....	See Center-Link
D50.....	203	Torques.....	129
D60, FD70.....	202	Transport System.....	
Reel Drive Sprocket.....		axle bolts.....	216
D50.....	200	field to transport.....	121
D60, FD70.....	199	tire inflation.....	216
Reel Endshield Kit.....	235	transport to field.....	116
Reel Tines.....		wheel bolt torque.....	216
plastic.....	208	Transporting Header.....	
replacement.....	207	on combine.....	115
steel.....	207	tow.....	115
Rice Divider Kit.....	236	Troubleshooting.....	
Rock Retarder Kit.....	236	crop loss.....	221
Roller Chain.....	131	cutting action.....	222
Safety.....		drapers.....	226
decals locations - export.....	15	edible beans.....	229
decals locations - N.A.....	8	FD70 FlexDraper.....	228
decals.....	7	header.....	226
general.....	20	reel delivery.....	224



## INDEX

sickle components .....	222	Wing	
Unloading .....	237	balance .....	213
Unplug Cutterbar .....	113	float .....	213
Upper Cross Auger		lock .....	95
operation .....	114	Wobble Box	
the kit .....	235	installation .....	179
Vertical Knife Mounts .....	235	mounting bolts .....	178
Vibration Dampers		oil change .....	180
installation .....	66	oil level .....	146
pad replacement .....	164	pulley removal/installation .....	178
Windrowing .....	124	removal .....	178