

MacDon™

A30-S and A30-D Pull-Type Mower Conditioner Unloading and Assembly Instructions



**MACDON A30-D PULL-TYPE
MOWER CONDITIONER**

INTRODUCTION

This instructional manual describes the unloading, set-up and pre-delivery requirements for the Model A30-S and A30-D Pull-Type Mower Conditioners.

Use the Table of Contents below to guide you to specific areas.

CAREFULLY READ ALL THE MATERIAL PROVIDED BEFORE ATTEMPTING TO UNLOAD, ASSEMBLE, OR USE THE MACHINE.

TABLE OF CONTENTS

INTRODUCTION	1
GENERAL SAFETY	3
RECOMMENDED TORQUES	5
A. GENERAL	5
B. SAE BOLTS	5
C. METRIC BOLTS.....	5
D. HYDRAULIC FITTINGS	6
ENGLISH/METRIC EQUIVALENTS	7
DEFINITIONS	7
STEP 1. UNLOAD ARTICULATING POWER TONGUE (APT)	8
A. TRUCK FLATBED	8
B. CONTAINER	8
STEP 2. UNLOAD HEADER	9
A. TRUCK FLATBED	9
B. CONTAINER	9
STEP 3. REMOVE SIDE DEFLECTORS	10
STEP 4. INSTALL GAUGE ROLLERS (Optional)	10
STEP 5. INSTALL ADDITIONAL SKID SHOES (Optional)	10
STEP 6. LOWER MOWER CONDITIONER	11
STEP 7. INSTALL WHEELS	12
STEP 8. REMOVE SHIPPING CHANNELS AND BLOCKING	13
STEP 9. UNPACK APT	14
STEP 10. ATTACH APT	15
STEP 11. CONNECT HOSES	16
STEP 12. ATTACH MOWER CONDITIONER TO TRACTOR	17
A. DRAWBAR TYPE HITCH.....	17
B. 3-POINT HITCH (Cat. II, III, IIIN)	20
STEP 13. ATTACH HYDRAULICS AND ELECTRICAL	23
STEP 14. INSTALL STEERING CYLINDER	25
STEP 15. INSTALL ROLL OPENER LINKS	27
STEP 16. INSTALL FORMING SHIELD COVER	28
STEP 17. INSTALL SIDE DEFLECTORS	28
STEP 18. ADJUST CENTER LINK	30
A. MECHANICAL LINK.....	30
B. HYDRAULIC LINK.....	30
STEP 19. ADJUST FLOAT SPRINGS	30
STEP 20. REPOSITION WOBBLE BOX BREATHER	31
STEP 21. ADJUST LEAN BAR	31
STEP 22. ADJUST TRANSPORT LIGHTS	31

STEP 23. INSTALL OPTIONS	32
A. GAUGE ROLLERS.....	32
B. SKID SHOES.....	33
C. STUB GUARDS	33
D. HYDRAULIC HEADER ANGLE	34
E. TALL CROP DIVIDER KIT	34
STEP 24. LUBRICATE THE MOWER CONDITIONER.....	35
A. HEADER DRIVE: A30-S	36
B. HEADER DRIVE: A30-S	37
C. HEADER DRIVE: A30-D	38
D. HEADER DRIVE: A30-D	39
E. HAY CONDITIONER: A30-S.....	40
F. HAY CONDITIONER: A30-D.....	41
G. CARRIER	42
H. ARTICULATING POWER TONGUE (APT)	43
STEP 25. PERFORM PRE-DELIVERY CHECKS	44
A. DRIVE BELTS AND CHAINS.....	44
B. AUGER STRIPPER BAR CLEARANCE	46
C. REEL TINE TO HEADER PAN CLEARANCE	46
D. HEADER FLOTATION	46
E. CONDITIONER ROLLS	47
F. SKID SHOES/GAUGE ROLLERS	48
G. LIGHTS.....	48
H. MANUALS	48
I. RUN-UP THE MOWER CONDITIONER.....	49
J. KNIFE	49

GENERAL SAFETY



CAUTION

The following are general farm safety precautions that should be part of your operating procedure for all types of machinery.

- Protect yourself.
- When assembling, operating and servicing machinery, wear all the protective clothing and personal safety devices that **COULD** be necessary for the job at hand. Don't take chances.
- You may need:

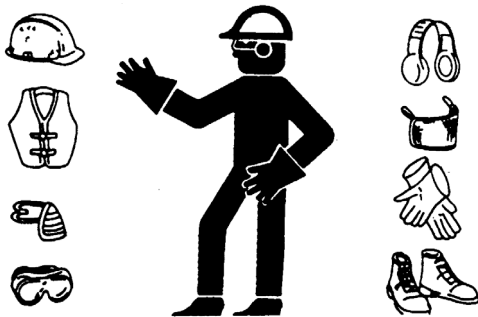

- a hard hat.
- protective shoes with slip resistant soles.
- protective glasses or goggles.
- heavy gloves.
- wet weather gear.
- respirator or filter mask.



- hearing protection. Be aware that prolonged exposure to loud noise can cause impairment or loss of hearing. Wearing a suitable hearing protective device such as ear muffs (A) or ear plugs (B) protects against objectionable or loud noises.



- Provide a first-aid kit for use in case of emergencies.
- Keep a fire extinguisher on the machine. Be sure the extinguisher is properly maintained and be familiar with its proper use.
- Keep young children away from machinery at all times.
- Be aware that accidents often happen when the operator is tired or in a hurry to get finished. Take the time to consider the safest way. Never ignore warning signs of fatigue.
- Wear close-fitting clothing and cover long hair. Never wear dangling items such as scarves or bracelets.
- Keep hands, feet, clothing and hair away from moving parts. Never attempt to clear obstructions or objects from a machine while the engine is running.

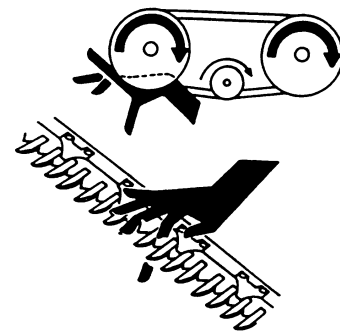

- Keep all shields in place. Never alter or remove safety equipment. Make sure driveline guards can rotate independently of the shaft, and can telescope freely.
- Use only service and repair parts made or approved by the equipment manufacturer. Substituted parts may not meet strength, design, or safety requirements.
- Do not modify the machine. Unauthorized modifications may impair the function and/or safety and affect machine life.

(continued next page)

- **Stop engine, and remove key from ignition before leaving Operator's seat for any reason. A child or even a pet could engage an idling machine.**
- **Keep the area used for servicing machinery clean and dry. Wet or oily floors are slippery. Wet spots can be dangerous when working with electrical equipment. Be sure all electrical outlets and tools are properly grounded.**
- **Use adequate light for the job at hand.**
- **Keep machinery clean. Do not allow oil or grease to accumulate on service platforms, ladders or controls. Clean machines before storage.**
- **Never use gasoline, naphtha or any volatile material for cleaning purposes. These materials may be toxic and/or flammable.**
- **When storing machinery, cover sharp or extending components to prevent injury from accidental contact.**



RECOMMENDED TORQUES

A. GENERAL

- Tighten all bolts to the torques specified in chart unless otherwise noted throughout this manual.
- Check tightness of bolts periodically, using bolt torque chart as a guide.
- Replace hardware with the same strength bolt.
- Torque figures are valid for non-greased or non-oiled threads and heads unless otherwise specified. Do not grease or oil bolts or capscrews unless specified in this manual.
- When using locking elements, increase torque values by 5%.

B. SAE BOLTS

BOLT DIA. "A" in.	NC BOLT TORQUE*			
	SAE 5		SAE 8	
	lbf-ft	N·m	lbf-ft	N·m
1/4	9	12	11	15
5/16	18	24	25	34
3/8	32	43	41	56
7/16	50	68	70	95
1/2	75	102	105	142
9/16	110	149	149	202
5/8	150	203	200	271
3/4	265	359	365	495
7/8	420	569	600	813
1	640	867	890	1205

* Torque categories for bolts and capscrews are identified by their head markings.

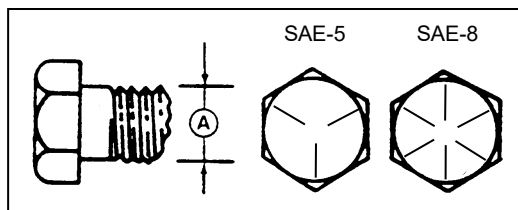

C. METRIC BOLTS

BOLT DIA. "A"	STD COARSE BOLT TORQUE*			
	8.8		10.9	
	lbf-ft	N·m	lbf-ft	N·m
M3	0.4	0.5	1.3	1.8
M4	2.2	3	3.3	4.5
M5	4	6	7	9
M6	7	10	11	15
M8	18	25	26	35
M10	37	50	52	70
M12	66	90	92	125
M14	103	140	148	200
M16	166	225	229	310
M20	321	435	450	610
M24	553	750	774	1050
M30	1103	1495	1550	2100
M36	1917	2600	2710	3675

* Torque categories for bolts and capscrews are identified by their head markings.

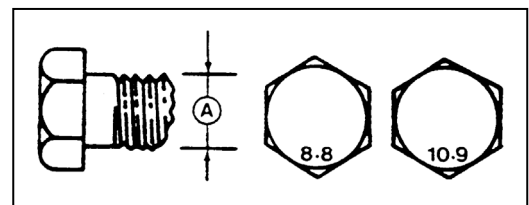

D. HYDRAULIC FITTINGS

FLARE TYPE

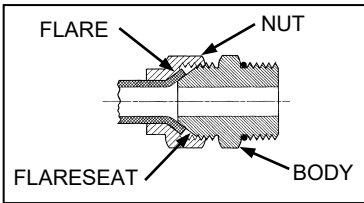

- Check flare and flare seat for defects that might cause leakage.
- Align tube with fitting before tightening.
- Lubricate connection and hand-tighten swivel nut until snug.
- To prevent twisting the tube(s), use two wrenches. Place one wrench on the connector body, and with the second, tighten the swivel nut to the torque shown.

SAE NO.	TUBE SIZE O.D. (in.)	THD SIZE (in.)	NUT SIZE ACROSS FLATS (in.)	TORQUE VALUE*		RECOMMENDED TURNS TO TIGHTEN (AFTER FINGER TIGHTENING)	
				ft·lbf	N·m	Flats	Turns
3	3/16	3/8	7/16	6	8	1	1/6
4	1/4	7/16	9/16	9	12	1	1/6
5	5/16	1/2	5/8	12	16	1	1/6
6	3/8	9/16	11/16	18	24	1	1/6
8	1/2	3/4	7/8	34	46	1	1/6
10	5/8	7/8	1	46	62	1	1/6
12	3/4	1-1/16	1-1/4	75	102	3/4	1/8
14	7/8	1-3/16	1-3/8	90	122	3/4	1/8
16	1	1-5/16	1-1/2	105	142	3/4	1/8

* The torque values shown are based on lubricated connections as in re-assembly.

O-RING TYPE

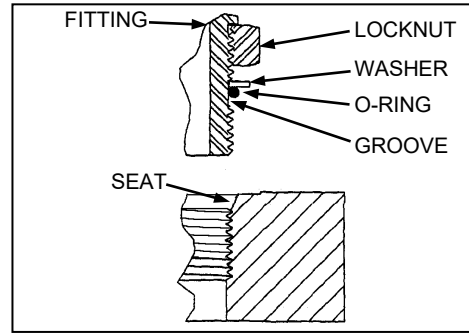

- Inspect O-ring and seat for dirt or obvious defects.

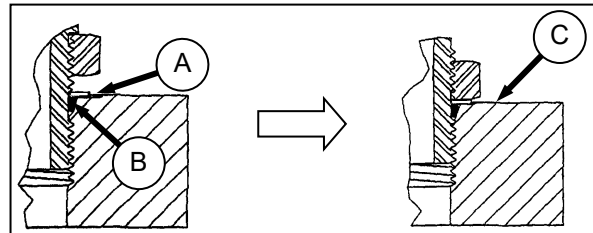

- On angle fittings, back off the lock nut until washer (A) “bottoms out” at top of groove (B) in fitting.
- Hand-tighten fitting until back up washer (A) or washer face (if straight fitting) bottoms on part face (C), and O-ring is seated.
- Position angle fittings by unscrewing no more than one turn.
- Tighten straight fittings to torque shown.
- Tighten angle fittings to torque shown in the following table, while holding body of fitting with a wrench.

SAE NO.	THD SIZE (in.)	NUT SIZE ACROSS FLATS (in.)	TORQUE VALUE*		RECOMMENDED TURNS TO TIGHTEN (AFTER FINGER TIGHTENING)	
			ft·lbf	N·m	Flats	Turns
3	3/8	1/2	6	8	2	1/3
4	7/16	9/16	9	12	2	1/3
5	1/2	5/8	12	16	2	1/3
6	9/16	11/16	18	24	2	1/3
8	3/4	7/8	34	46	2	1/3
10	7/8	1	46	62	1-1/2	1/4
12	1-1/16	1-1/4	75	102	1	1/6
14	1-3/16	1-3/8	90	122	1	1/6
16	1-5/16	1-1/2	105	142	3/4	1/8
20	1-5/8	1-7/8	140	190	3/4	1/8
24	1-7/8	2-1/8	160	217	1/2	1/12

* The torque values shown are based on lubricated connections as in re-assembly.

ENGLISH/METRIC EQUIVALENTS

QUANTITY	INCH-POUND UNITS		FACTOR	SI UNITS (METRIC)	
	UNIT NAME	ABBR.		UNIT NAME	ABBR.
Area	acres	acres	x 0.4047 =	hectares	ha
Flow	US gallons per minute	gpm	x 3.7854 =	liters per minute	L/min
Force	pounds force	lbf	x 4.4482 =	Newtons	N
Length	inch	in.	x 25.4 =	millimeters	mm
	foot	ft	x 0.305 =	meters	m
Power	horsepower	hp	x 0.7457 =	kilowatts	kW
Pressure	pounds per square inch	psi	x 6.8948 =	kilopascals	kPa
			x .00689 =	megapascals	MPa
Torque	pound feet or foot pounds	lbf·ft or ft·lbf	x 1.3558 =	newton meters	N·m
	pound inches or inch pounds	lbf·in. or in·lbf	x 0.1129 =	newton meters	N·m
Temperature	degrees Fahrenheit	°F	(°F - 32) x 0.56 =	Celsius	°C
Velocity	feet per minute	ft/min	x 0.3048 =	meters per minute	m/min
	feet per second	ft/s	x 0.3048 =	meters per second	m/s
	miles per hour	mph	x 1.6063 =	kilometers per hour	km/h
Volume	US gallons	US gal.	x 3.7854 =	liters	L
	ounces	oz.	x 29.5735 =	milliliters	ml
	cubic inches	in. ³	x 16.3871 =	cubic centimeters	cm ³ or cc
Weight	pounds	lb	x 0.4536 =	kilograms	kg

DEFINITIONS

TERM	DEFINITION
API	American Petroleum Institute
APT	Articulating Power Tongue
ASTM	American Society Of Testing And Materials
Header	The removable portion of a harvesting machine (windrower, combine, mower) that cuts and conveys crops to a delivery opening. Includes sickle, reel and conveying systems.
Mower Conditioner	A machine that cuts and conditions hay, and is pulled by an agricultural type tractor.
PTO	Power Take-Off
rpm	Revolutions Per Minute
SAE	Society Of Automotive Engineers
Tractor	Agricultural type tractor.
Wobble Box	An enclosed system that translates rotating motion from the machine drive into reciprocating motion to the sickle.

UNLOADING AND ASSEMBLY

STEP 1. UNLOAD ARTICULATING POWER TONGUE (APT)



CAUTION

To avoid injury to bystanders from being struck by machinery, do not allow persons to stand in unloading area.



CAUTION

Equipment used for unloading must meet or exceed the requirements specified below. Using inadequate equipment may result in chain breakage, vehicle tipping or machine damage.

LIFTING VEHICLE	
MINIMUM CAPACITY	8000 lb (3630 kg)
MINIMUM LIFTING HEIGHT	15 ft (4.5 m)

CHAIN	
OVERHEAD LIFTING QUALITY (1/2 INCH)	5000 lb (2270 kg) MINIMUM WORKING LOAD

A. TRUCK FLATBED

- a. Remove hauler's tie down straps and chains.



- b. Attach chain to two brackets on top of APT as shown.
- c. Adjust chain lengths so APT is lifted evenly.
- d. Raise APT off deck, back up until unit clears trailer, and slowly lower to 6 inches (150 mm) from ground.

IMPORTANT

Take care not to contact the other machine if load is two-wide.

- e. Take to storage or set-up area, and set APT down securely on level ground.
- f. Repeat for second APT if required.
- g. Check for shipping damage and missing parts.

B. CONTAINER

- a. Open container doors, and remove all blocking.
- b. Check container floor for nails or other obstructions, and remove if necessary.
- c. Unload tires and other loose components.

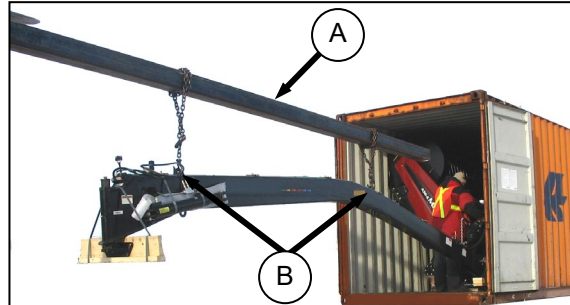

- d. Position boom (A) inside container with forklift.
- e. Attach chains to hooks (B) on APT and to boom.
- f. Lift APT, and slowly back forklift away from container.

IMPORTANT

Take care not to contact the other machine inside container.

- g. Take to storage or set-up area, and set APT down securely on level ground.
- h. Repeat for second APT if required.
- i. Check for shipping damage and missing parts.

UNLOADING AND ASSEMBLY

STEP 2. UNLOAD HEADER



CAUTION

To avoid injury to bystanders from being struck by machinery, do not allow persons to stand in unloading area.



CAUTION

Equipment used for unloading must meet or exceed the requirements specified below. Using inadequate equipment may result in chain breakage, vehicle tipping or machine damage.

LIFTING VEHICLE	
MINIMUM CAPACITY	8000 lb (3630 kg)
MINIMUM LIFTING HEIGHT	15 ft (4.5 m)

CHAIN	
OVERHEAD LIFTING QUALITY (1/2 INCH)	5000 lb (2270 kg) MINIMUM WORKING LOAD



WARNING

Be sure forks are secure before moving away from load. Stand clear when lifting.

A. TRUCK FLATBED

- a. Remove hauler's tie down straps and chains.

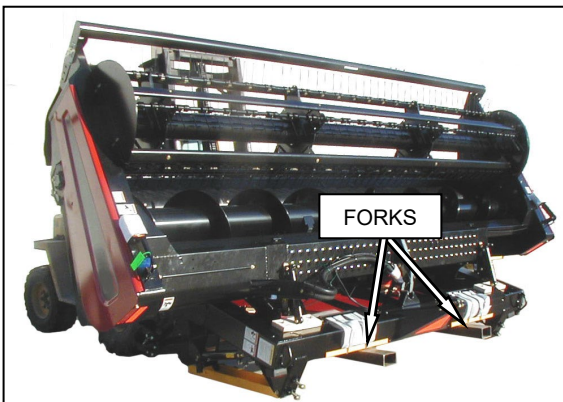

- b. Approach mower conditioner from either its "underside" or "topside", and slide forks in underneath lifting framework as far as possible.

NOTE

When possible, approach from the underside to minimize potential for scratching the unit.

- c. Raise mower conditioner off deck.

IMPORTANT

Take care not to contact the other machine if load is two-wide.

- d. Back up until unit clears trailer, and slowly lower to 6 inches (150 mm) from ground.
- e. Take to storage or set-up area
- f. Set machine down securely on level ground.
- g. Repeat for other mower conditioner if required.
- h. Check for shipping damage and missing parts.

B. CONTAINER

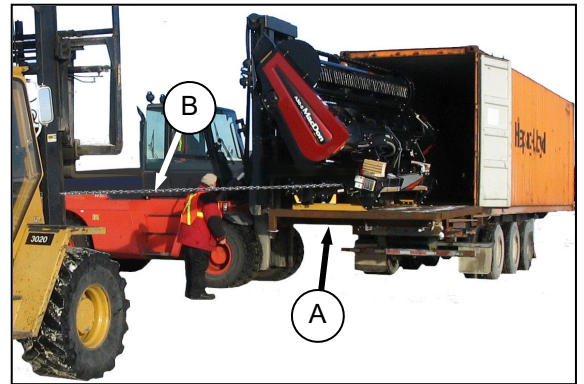

- a. Position platform (A) at container opening with forklift.
- b. Attach chain (B) to header frame and to forks on a second forklift.
- c. Pull header from container onto platform.
- d. Lift platform slightly to take weight off container.
- e. Slowly drive trailer with container away from header, carefully watching all clearances and repositioning header as required.
- f. When container is clear of header, remove chain from frame, and lower platform and header to ground.

(continued next page)

UNLOADING AND ASSEMBLY



- g. Approach from underside, lift header off platform, and take to storage or set-up area.
- h. Set machine down securely on level ground.
- i. Repeat for other header.
- j. Check headers for shipping damage and missing parts.

STEP 3. REMOVE SIDE DEFLECTORS

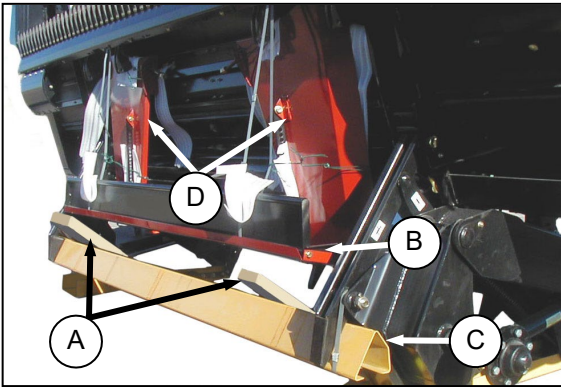

- a. Place wooden blocks (A) between forming shield top cover (B) and lifting beam (C).
- b. Cut shipping bands, and remove side deflectors (D).
- c. Leave lifting framework in place to support the top cover as the windrower is lowered.

STEP 4. INSTALL GAUGE ROLLERS (Optional)

NOTE

This kit may be installed later in the header assembly sequence, but it may be easier prior to laying the header down.

If kit not supplied, proceed to STEP 5. INSTALL ADDITIONAL SKID SHOES (Optional). Otherwise refer to STEP 23A. GAUGE ROLLERS for installation details.

STEP 5. INSTALL ADDITIONAL SKID SHOES (Optional)

NOTE

This kit may be installed later in the header assembly sequence, but it may be easier prior to laying the header down.

If kit not supplied, proceed to STEP 6. LOWER MOWER CONDITIONER. Otherwise refer to STEP 23B. SKID SHOES for installation details.

UNLOADING AND ASSEMBLY

STEP 6. LOWER MOWER CONDITIONER

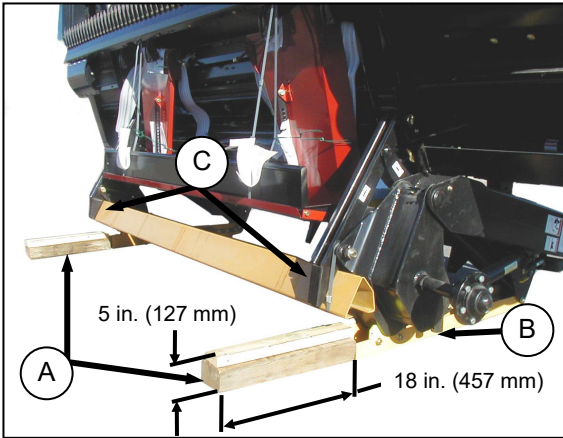

- a. Place wooden blocks (A) against end of shipping channels (B), and align blocks with lower links (C).

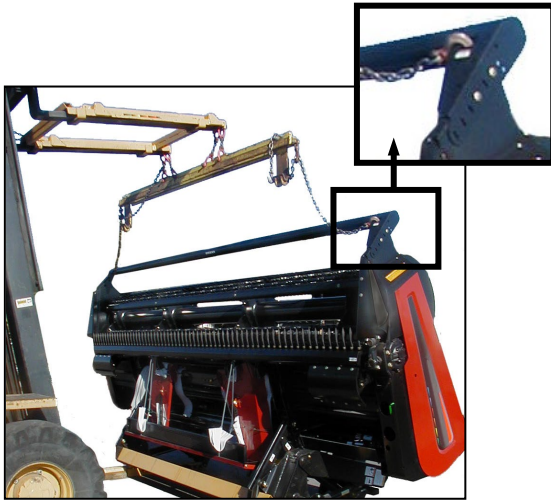

LOWERING HEADER WITH FORKLIFT

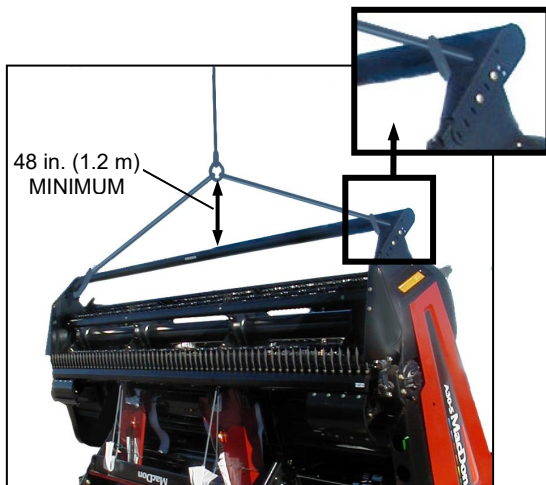

LOWERING HEADER WITH CRANE

- b. Attach either a spreader bar or chain to forks.



CAUTION

Ensure spreader bar or chain is secured to the forks so that it cannot slide off the forks or towards the mast as the header is lowered to the ground.

CHAIN TYPE	OVERHEAD LIFTING QUALITY (1/2 INCH)
MINIMUM WORKING LOAD	5000 lb (2270 kg)

- c. Drive lifting vehicle to approach header from its "underside".
 d. Attach chain hooks to hooks on either side of header.



CAUTION

Stand clear when lowering the header.

NOTE

Do not lift at hooks when unloading from trailer. This procedure is only for laying the machine over into working position.

IMPORTANT

Chain length must be sufficient to provide a minimum 4 feet (1.2 m) vertical chain height.

- e. Raise forks until lift chains are fully tensioned.

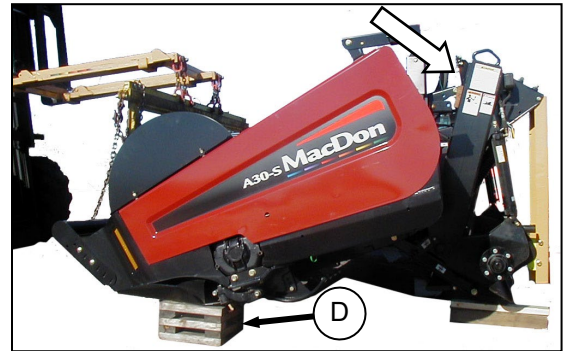

- f. Back up SLOWLY, while simultaneously lowering machine so that cutterbar skid shoes rest on blocks (D).

NOTE

The front face of the carrier mast should be approximately vertical for easier assembly of the APT.

- g. Remove chain from header.

UNLOADING AND ASSEMBLY

STEP 7. INSTALL WHEELS

- a. Remove wheel bolts from wheel hub.



CAUTION

When installing wheel be sure to use the holes that are countersunk to match bolt head profile. The “non-countersunk” holes do not seat the bolts correctly.

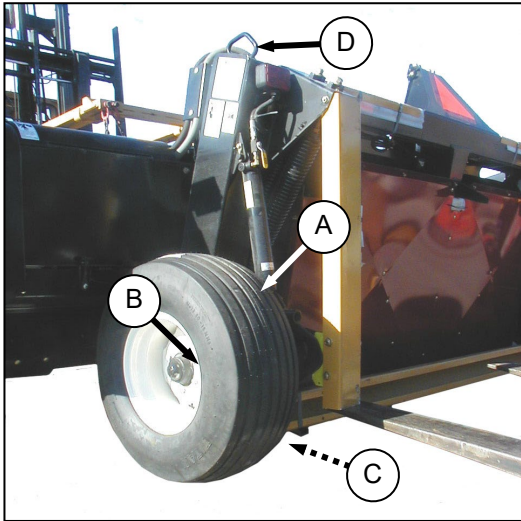

- b. Install wheels (A) with existing bolts. Be sure valve stem (B) points away from wheel support.

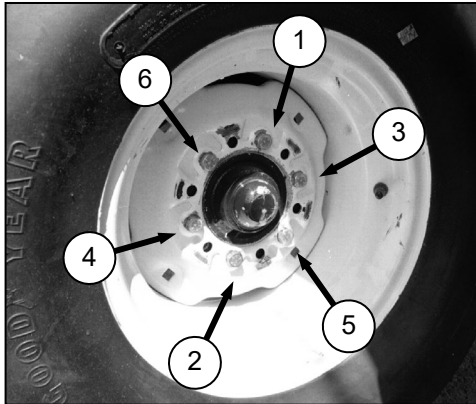

- c. Torque bolts to 120 ft·lbf (160 N·m), following tightening sequence shown above.

IMPORTANT

Follow proper bolt tightening sequence shown above.

- d. Raise aft end of header with forklift so that blocks (C) under lower links can be removed. Chain may also be used at hook (D).
e. Lower header onto wheels.

- f. Check tires inflated to 30 psi (207 kPa).

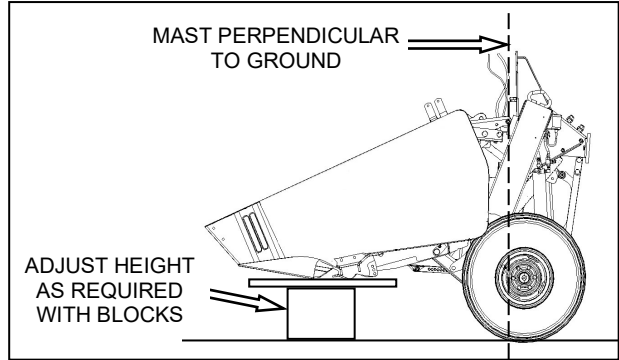

- g. Check that frame is sitting at proper angle, with APT pivot pin mounting hole perpendicular to ground. Adjust height of blocks as required.

UNLOADING AND ASSEMBLY

STEP 8. REMOVE SHIPPING CHANNELS AND BLOCKING



CAUTION

Keep feet clear when removing banding.

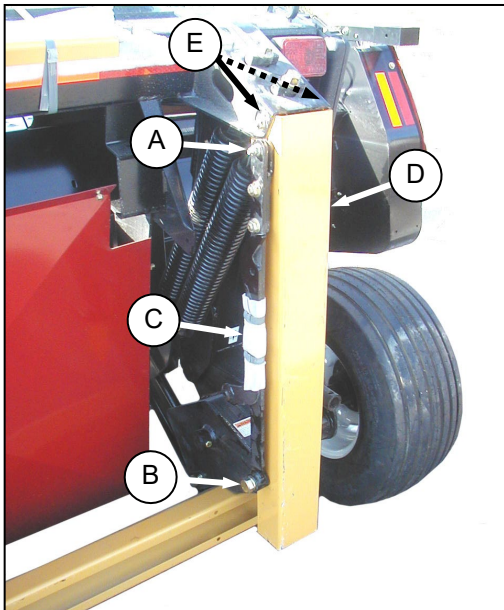

- Remove bolts (A) and (B), and remove banded link and arm (C) from shipping channel (D) at each float spring mount. Retain bolts (A) and (B) for re-installation.
- Remove bolts (E), and remove shipping channel (D). Discard.

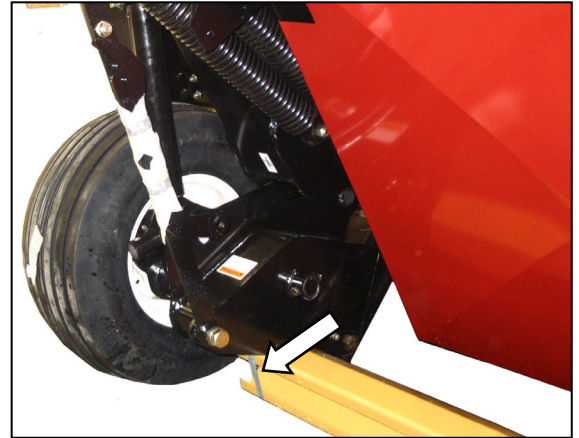

- Remove banding at ends of shipping beam, and let beam fall to ground.

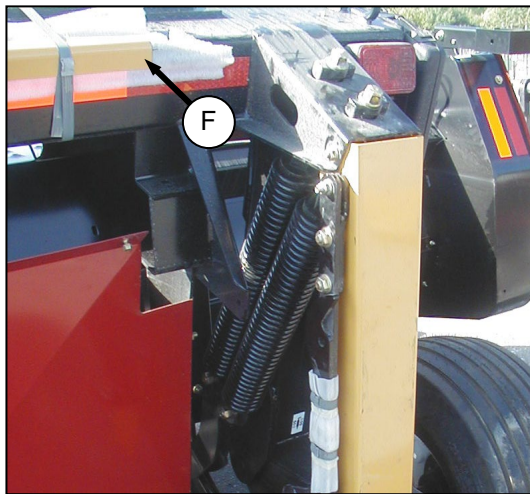

- Remove banding, and remove the two shipping angles (F). Discard.

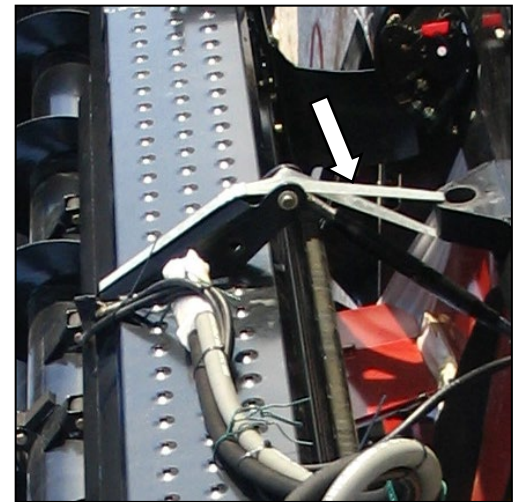

- Remove banding at center link location.

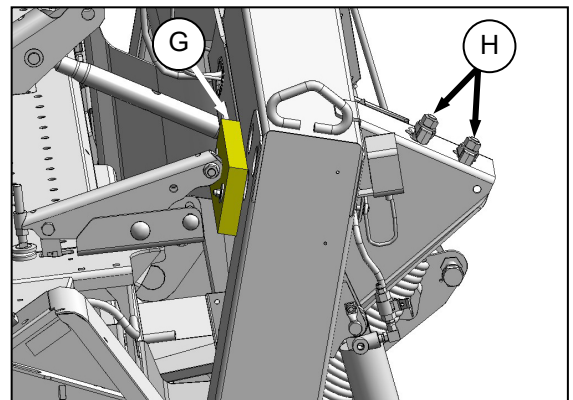

- Loosen float springs by turning bolts (H) counter clockwise on both sides of frame, so that blocks (G) can be removed.

UNLOADING AND ASSEMBLY

STEP 9. UNPACK APT

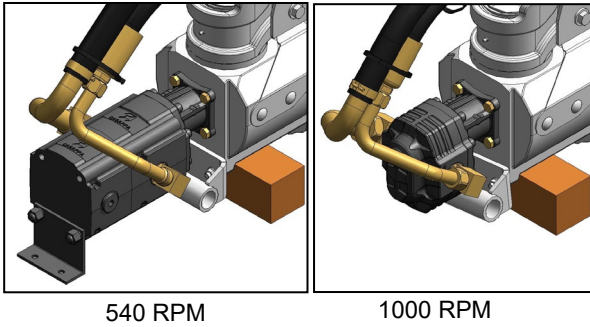

IMPORTANT

If there is more than one machine to be assembled, and they are different PTO speeds (540 or 1000 RPM), be sure the proper APT is matched to each unit. They are identified on a plastic tag tied to the hose support near the front end.

Should this tag be missing, they can be identified by the pump. See above illustrations.



- Attach chain from lifting vehicle, or hoist to APT hooks, and raise it approximately 24 inches (610 mm) off ground.

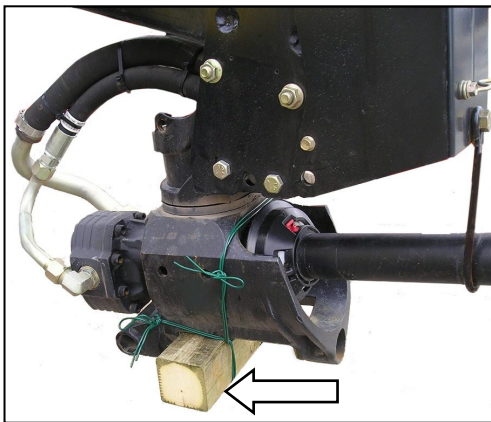

- Remove shipping wire and wooden block from under pump.

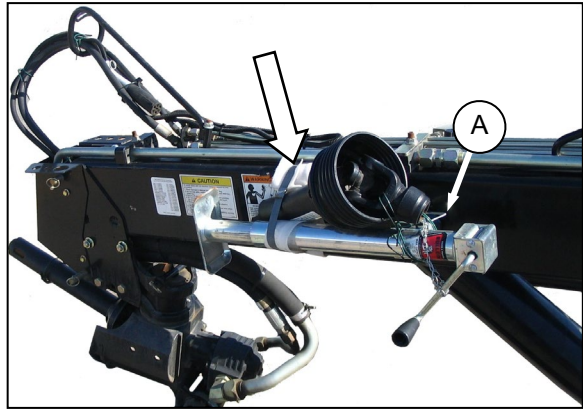

- Remove banding and shipping wire from jack and driveline half-shaft. Set driveline half-shaft aside.
- Remove pin (A) securing jack to APT, and remove jack from shipping position.

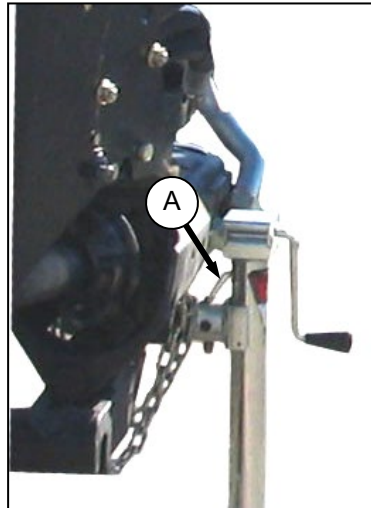

- Install at jack location at front of APT, and secure with pin (A).

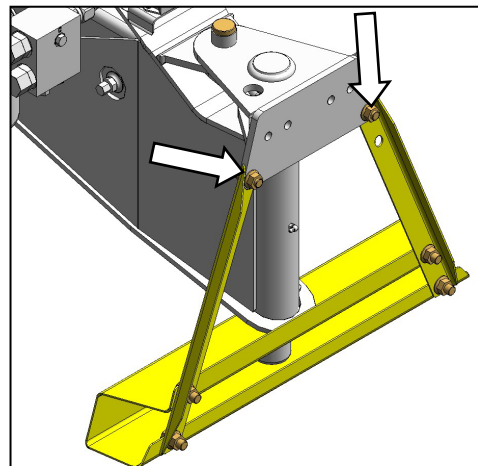

- Remove the two bolts securing aft shipping stand to APT, and remove stand.

UNLOADING AND ASSEMBLY

STEP 10. ATTACH APT



CAUTION

Keep hands clear when lowering APT.



- a. Remove the six bolts and nuts from frame, and retain for re-installation.

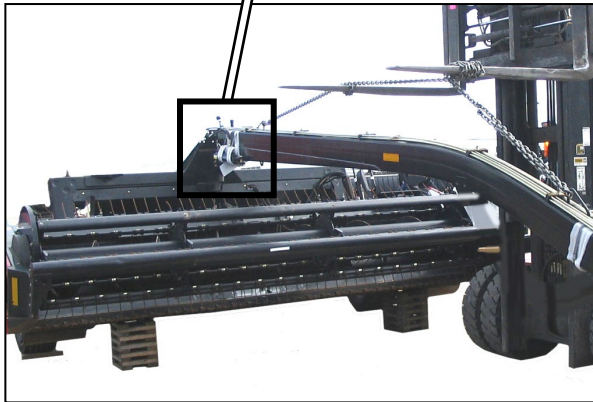
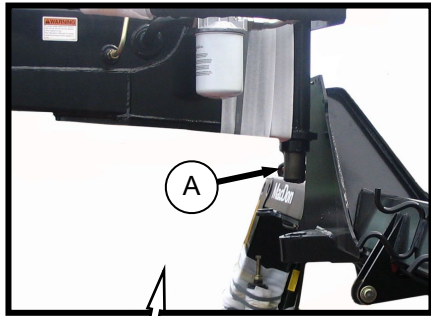

- b. Using a forklift or equivalent, manoeuvre APT into position, and install pivot pin (A) into mower conditioner carrier frame.

NOTE

Use the jack to adjust the pitch of the APT for proper alignment when installing pivot pin.

NOTE

Pin may need to be tapped into final position with a hammer due to the tight clearances.

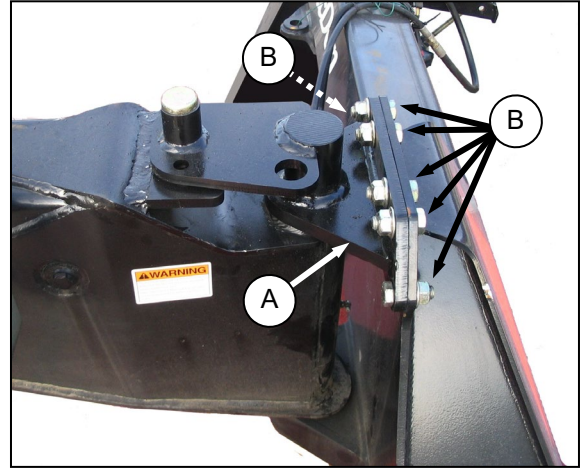

- c. Secure pivot pin (A) to frame by installing six 5/8 x 1.75 long Gr. 8 bolts (B) with lock nuts removed at step a. Install bolts with heads facing aft.
- d. Torque to 250 ft·lbf (339 N·m).

UNLOADING AND ASSEMBLY

STEP 11. CONNECT HOSES

IMPORTANT

Hoses should be routed so there are no twists or sharp bends, and no locations where contact with the frame is likely. Ensure that there is sufficient length of hose and wiring in span to accommodate full swing of APT in both directions. Re-locate plastic ties if necessary to provide suitable slack in hoses and wiring.

IMPORTANT

To prevent contamination of the hydraulic system, extreme care must be taken to avoid dirt entering at connection points. To minimize exposure to contamination, remove cap from one hose and its mating connection, and connect before removing other caps and plugs.

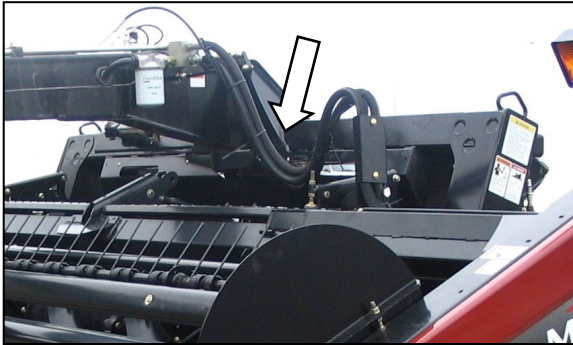

- Cut shipping wire holding hoses on the walk platform, and route to connections at aft end of APT.
- Remove wrapping from hose ends. Do not remove cable ties holding hoses together.
- Remove caps and plugs from manifold and hoses.

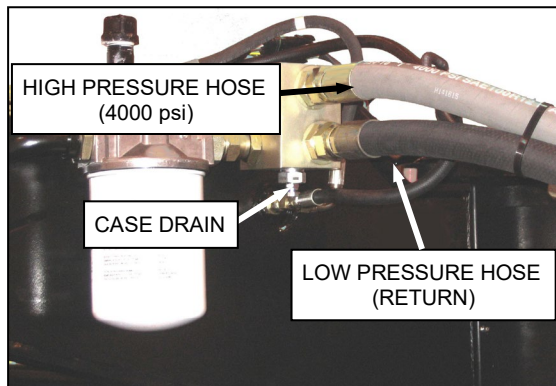

- Connect the three header drive motor hoses to the pressure relief/filter manifold as shown.

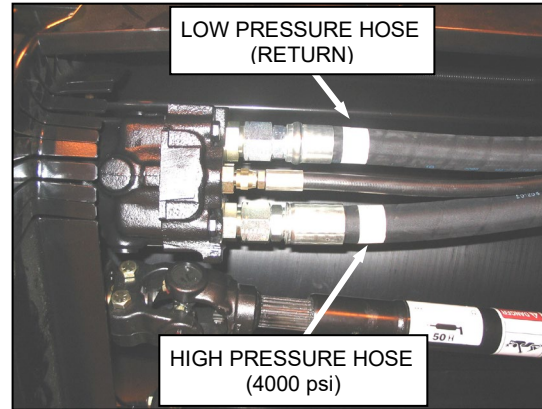

IMPORTANT

Ensure that pressure and return hoses are connected to the proper fitting as shown. High pressure hose is marked with "4000 psi", and is slightly larger and stiffer than return hose. Check that it connects to lower fitting on motor as shown. Tighten all hoses securely.

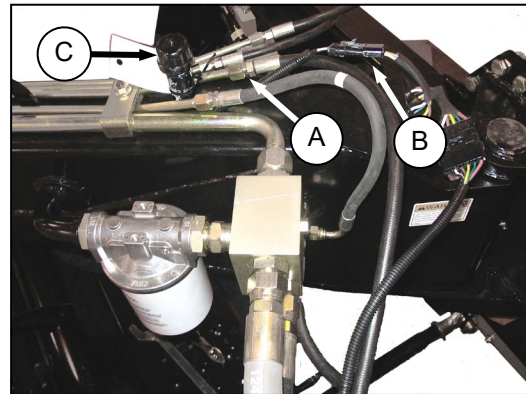

- Connect the lift cylinder hose (A) and wiring harness (B) to the respective fittings on the APT.

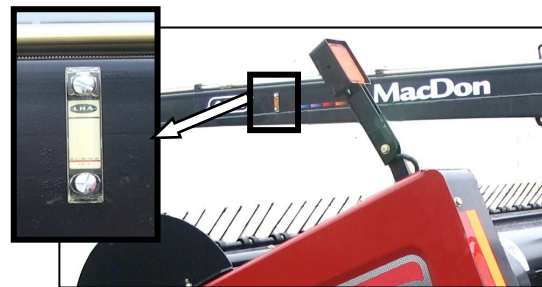

- Check oil level is between ADD and FULL marks on sight gauge on side of APT. If required, add oil as follows:
 - Slowly unscrew filler cap (C) from filler tube.
 - Add SAE 15W40 oil until level is between ADD and FULL marks on sight gauge.
 - Replace filler cap.

UNLOADING AND ASSEMBLY

STEP 12. ATTACH MOWER CONDITIONER TO TRACTOR



CAUTION

Shut off tractor, engage parking brake and remove key before working around hitch.

A. DRAWBAR TYPE HITCH

I. SET UP THE DRAWBAR

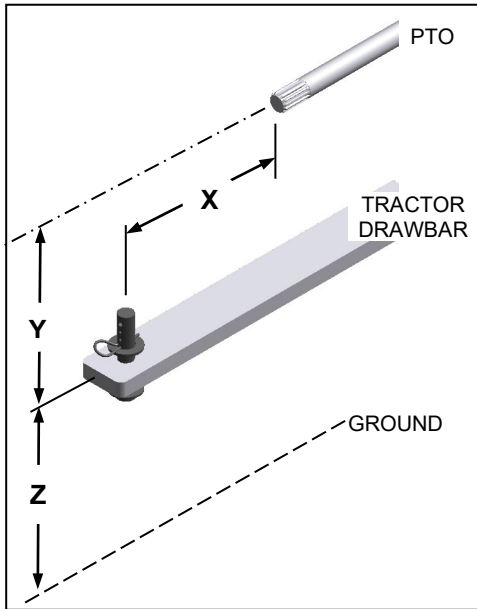

- a. Adjust tractor drawbar to meet ASAE Standard specifications as listed below.

DIMENSION	1000 RPM PTO	
	1.37 IN. DIA.	1.75 IN. DIA.
X	16 in. (406 mm)	20 in. (508 mm)
Y	6 - 12 in. (152 - 305 mm) 8 in. (203 mm) Recommended	
Z	13 - 17 in. (330 - 432 mm) 16 in. (406 mm) Recommended	

IMPORTANT

Improper drawbar length can cause driveline vibration and premature wear on the pump and gearbox.

II. ATTACH DRAWBAR EXTENSION

- a. Secure the tractor drawbar so the hitch-pin hole is directly below the driveline.

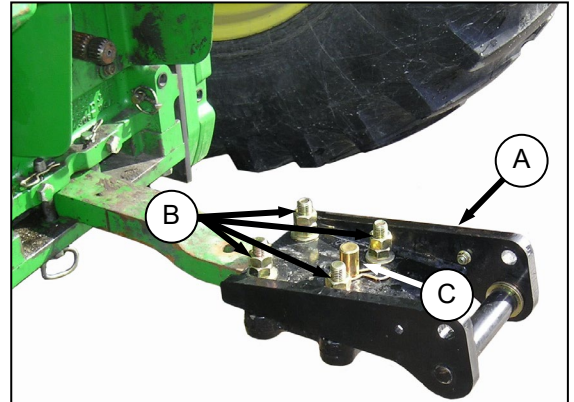

- b. Loosen bolts (B) on extension assembly (A), and slide onto drawbar.
- c. Install pin (C) through drawbar and extension from underside, and secure with hairpin.
- d. Gradually tighten the four bolts to 265 ft·lbf (359 N·m).

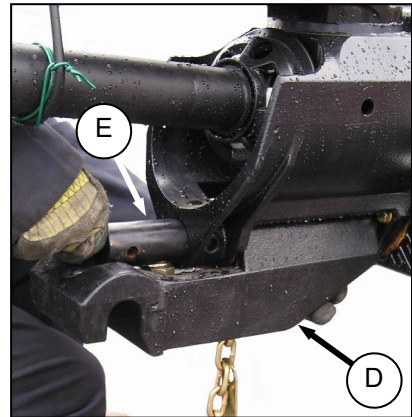

- e. Attach the swivel APT member (D) with pin (E) onto the APT.

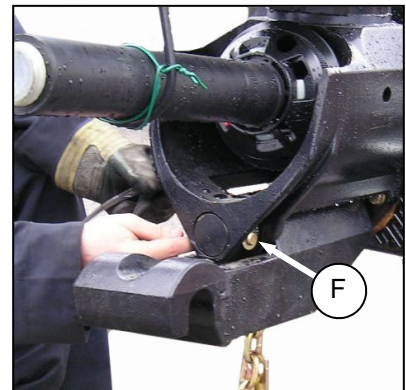

- f. Secure pin with clevis pin (F), washers, and cotter pin.

(continued next page)

UNLOADING AND ASSEMBLY

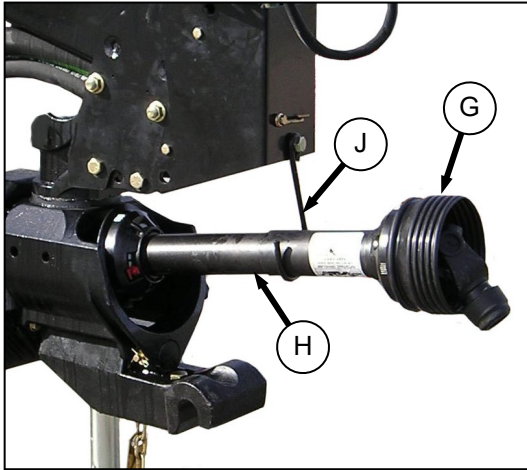

- g. Assemble PTO driveline male half (G) onto PTO shaft (H) on APT. Push male half so that PTO shaft is at its "fully compressed" length.
- h. Locate PTO shaft in hook (J).

III. ATTACH MOWER CONDITIONER TO TRACTOR

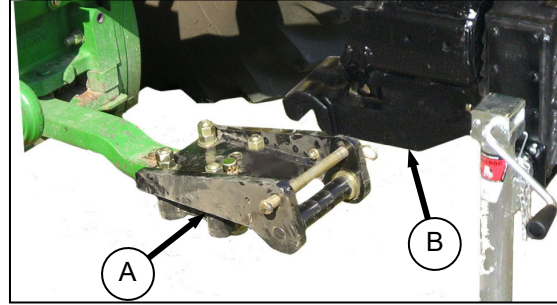

- a. Start engine, and position tractor to align drawbar extension (A) with arm (B) on mower conditioner APT.



CAUTION

Stop engine, and remove key from ignition before leaving Operator's seat for any reason. A child or even a pet could engage an idling machine.

- b. Set park brake, stop engine, and remove key.

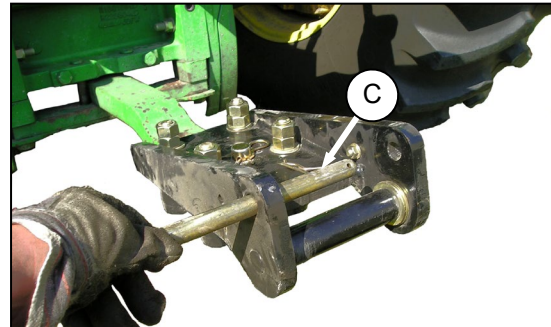

- c. Remove pin (C).

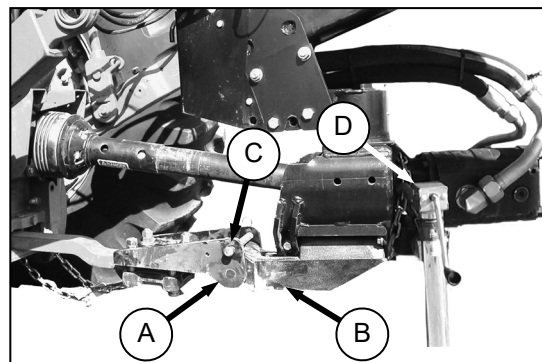

- d. Raise jack (D) to engage arm (B) on drawbar extension (A).

(continued next page)

UNLOADING AND ASSEMBLY

- e. Install hitch-pin (C), and secure with hairpin.

IMPORTANT

If the tractor has a three-point hitch, lower the lower links as low as possible to prevent damage to APT.

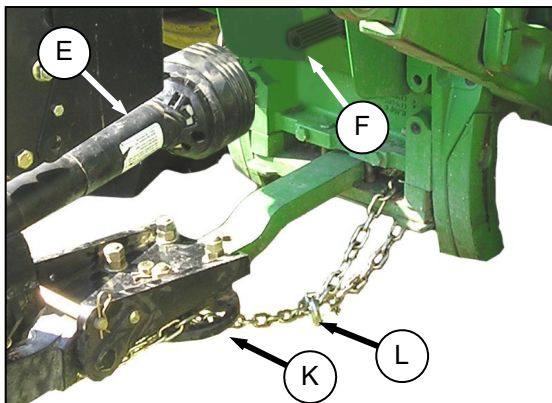

- f. Attach driveline (E) to tractor PTO shaft as follows:
1. Position driveline onto tractor PTO shaft (F).
 2. Pull back collar on driveline, and push until it locks. Release collar.
- g. Route safety chain from mower conditioner through chain support (K), around drawbar support, and lock the hook (L) on chain.

IMPORTANT

Adjust safety chain length to remove all slack except what is needed for turns.

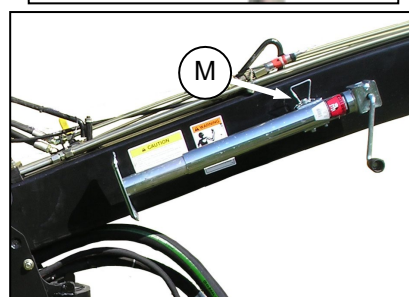
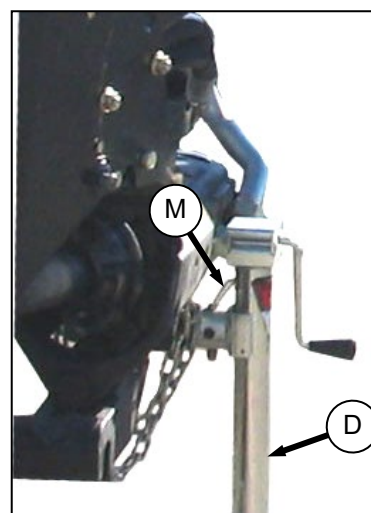

- h. Raise jack (D), pull pin (M), and move jack to storage position on side of APT.
- i. Secure jack with pin (M).
- j. Proceed to STEP 13. ATTACH HYDRAULICS AND ELECTRICAL.

UNLOADING AND ASSEMBLY

B. 3-POINT HITCH (CAT. II, III, IIIN)

I. INSTALL THE 3-POINT HITCH YOKE

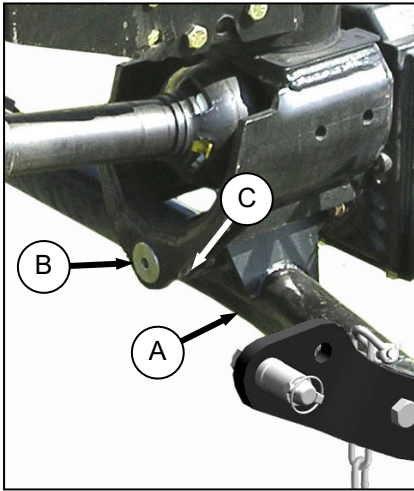

- Attach the 3 point hitch yoke (A) to the APT with pin (B). The installation is similar to that described in the previous section.
- Secure pin (B) with clevis pin (C), washers, and cotter pin.

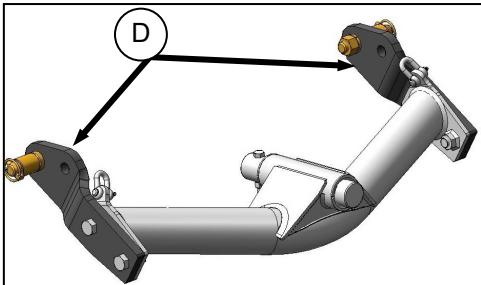

CATEGORY II or IIIN

- The arms (D) on APT yoke can be set up to suit the tractor hitch arms:

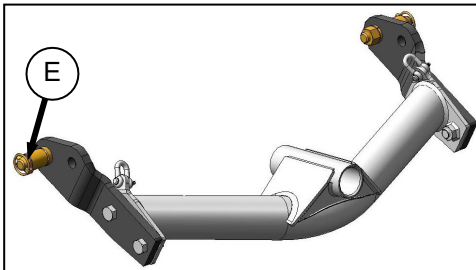

CATEGORY III

- Remove pins (E) from arms.
- Remove arms (D) from APT yoke.
- Re-install arms on opposite ends of yoke as shown.
- Re-install pins (E) in arms.

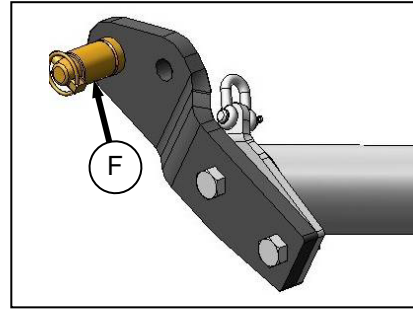

NOTE

Bushings (F) on pins can be removed to suit hole size in tractor hitch arms.

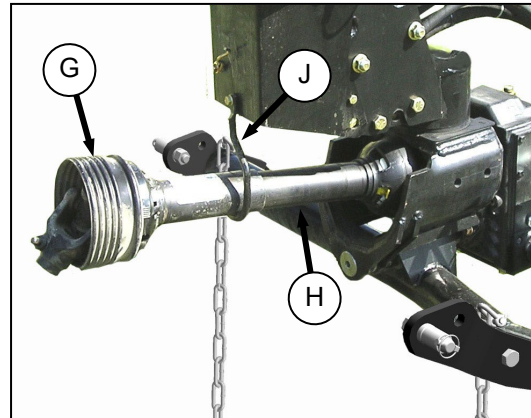

- Assemble PTO driveline male half (G) onto PTO shaft (H) on APT. Push male half so that PTO shaft is at its "fully compressed" length.
- Locate PTO shaft in hook (J).

UNLOADING AND ASSEMBLY

II. ATTACH MOWER CONDITIONER TO TRACTOR

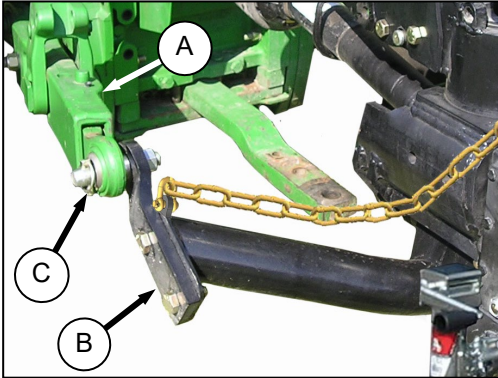

CAT. II and IIIN CONFIGURATION

- a. Position tractor, and align tractor hitch arms (A) with windrower arms (B).



CAUTION

Stop engine, and remove key from ignition before leaving Operator's seat for any reason. A child or even a pet could engage an idling machine.

- b. Stop engine, and remove key.
- c. Use the jack to adjust height of windrower.
- d. Secure arms with lynch pins (C).
- e. Install anti-sway bars on tractor hitch to stabilize lateral movement of hitch arms (A). Refer to your tractor Operator's Manual.

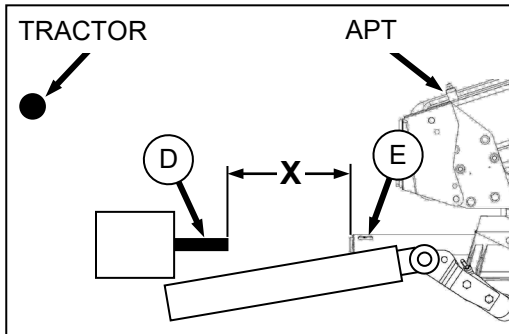

- f. Check distance 'X' between tractor PTO shaft (D) and implement input shaft (E) (without the front half of the driveline attached).

IMPORTANT

The measurement must not exceed the distance 'X' specified values in the following table. Otherwise, the driveline can vibrate and cause premature failure of the driveline and pump gearbox:

DRIVELINE SHAFT SIZE	DISTANCE 'X'
1.375 in. (34 mm)	14 in. (356 mm)
1.75 in. (43 mm)	17 in. (432 mm)

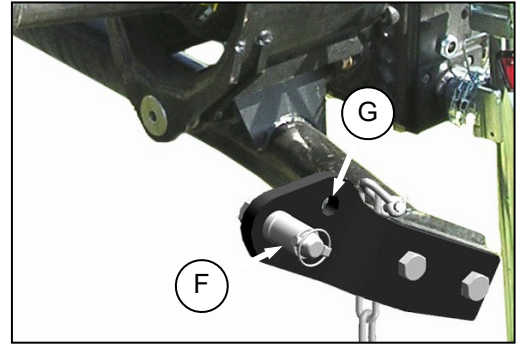

- g. Change locations of pins (F) in APT arms to hole (G) to locate implement closer to tractor (if necessary).

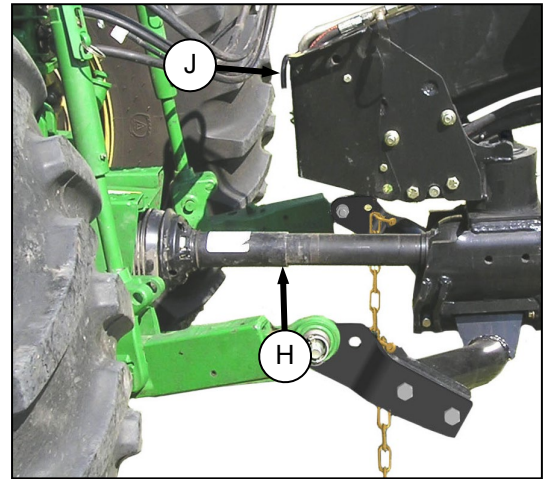

- h. Position driveshaft (H) onto tractor PTO shaft. Driveline should be approximately level.
- i. Pull back collar on driveshaft, and push driveshaft until it locks. Release collar.
- j. Rotate driveline storage hook (J) to "upward" position.

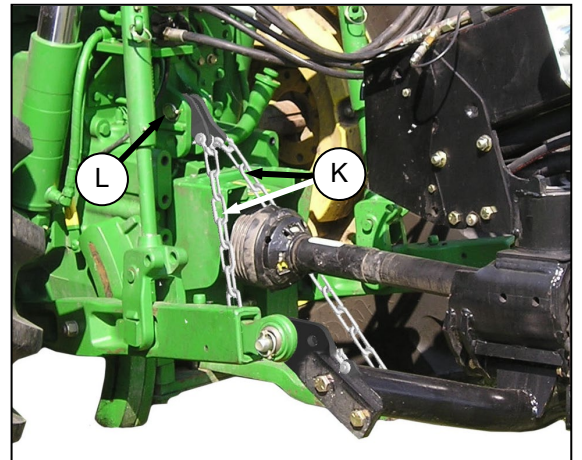

- k. Attach down-stop chains (K) to pin (L) on tractor.

(continued next page)

UNLOADING AND ASSEMBLY



CAUTION

The downstop chains limit the downward travel of the 3-point hitch lifting arms to prevent damaging the PTO driveline on the mower conditioner.

Ensure chains are attached when operating the mower conditioner.

- I. Adjust chain length as required by relocating end link at tractor end of chain as follows:

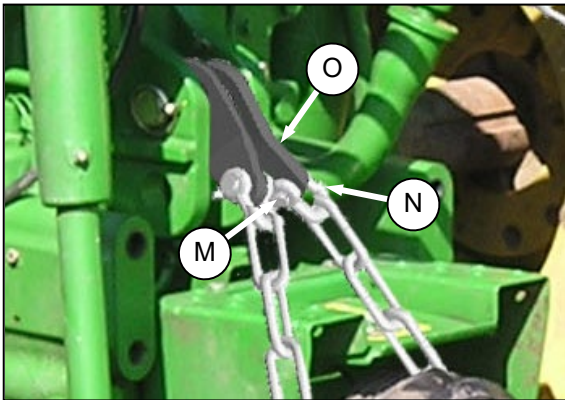

1. Remove cotter pin and clevis pin (M) to disconnect open link (N) and end link (O).
2. Re-locate open link (N) to new location on chain, and re-attach to end link (O) with clevis pin (M). Chains do not need to be tight.
3. Secure clevis pin with cotter pin.

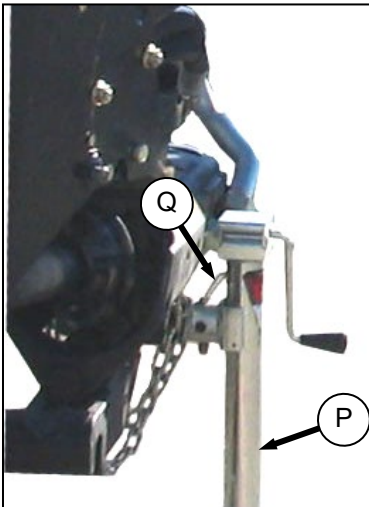

- m. Raise jack (P), pull pin (Q), and move jack to storage position on side of APT.

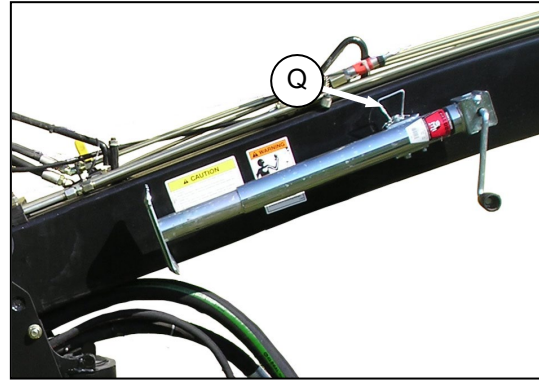

- n. Secure jack with pin (Q).

UNLOADING AND ASSEMBLY

STEP 13. ATTACH HYDRAULICS AND ELECTRICAL



WARNING

Do **not** use remote hydraulic system pressures over 3000 psi (20684 kPa). Check your tractor Operator's Manual for remote system pressure.

- a. Install quick disconnect couplers onto hydraulic hoses at front of APT as per following table. Use #8 ORB (3/4 inch - 16 UNF Thread).

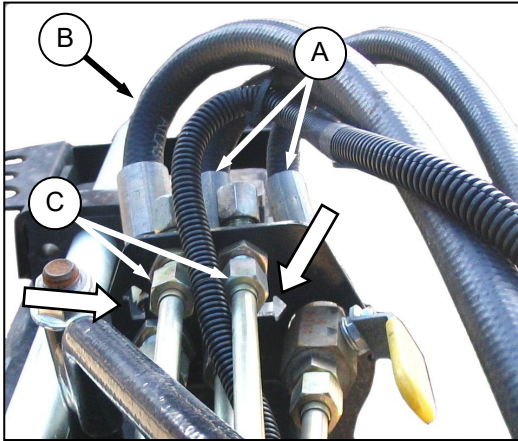

SYSTEM	HOSE	TRACTOR HYDRAULICS
Steering	A (2 Hoses)	Control 1
Lift	B (1 Hose)	Control 2
Header Tilt	C (2 Hoses)	Control 3

NOTE

Arrows cut into plate indicate system for hoses. LIFT ↑ STEERING ↔

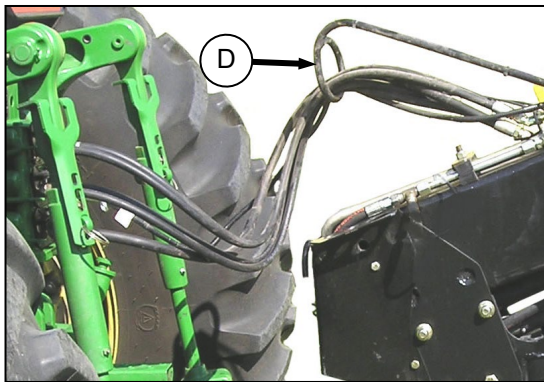

- b. Ensure hoses are routed through guide (D) to provide proper hose arc as shown.

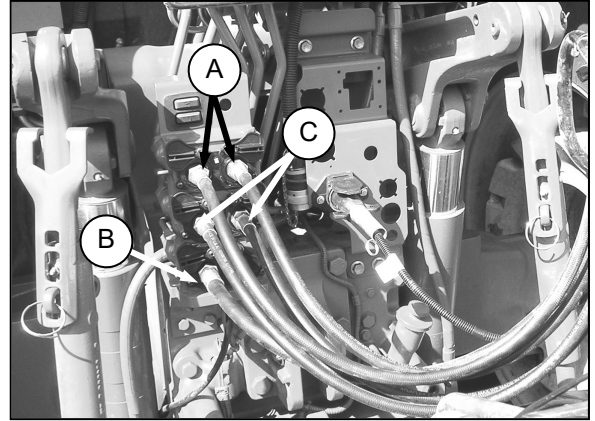

- c. Connect two **steering** cylinder hoses (A) as follows:

CONTROL LEVER POSITION	CYLINDER MOVEMENT	MOWER CONDITIONER DIRECTION
Forward	Extend	Right
Backward	Retract	Left

- d. Connect one **lift** cylinder hose (B) as follows:

CONTROL LEVER POSITION	CYLINDER MOVEMENT	HEADER MOVEMENT
Forward	Retract	Lower
Backward	Extend	Raise

- e. Connect two **header tilt** cylinder hoses (C) as follows: (Not required with mechanical center link).

CONTROL LEVER POSITION	CYLINDER MOVEMENT	HEADER MOVEMENT (TILT)
Forward	Extend	Steeper
Backward	Retract	Flatter

(continued next page)

UNLOADING AND ASSEMBLY

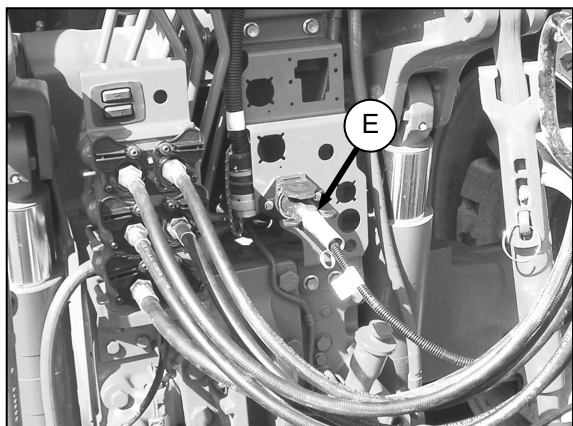

- f. Connect the mower conditioner wiring harness connector (E) to tractor. The connector is designed to fit tractors equipped with a round 7-pin receptacle (SAE J560).

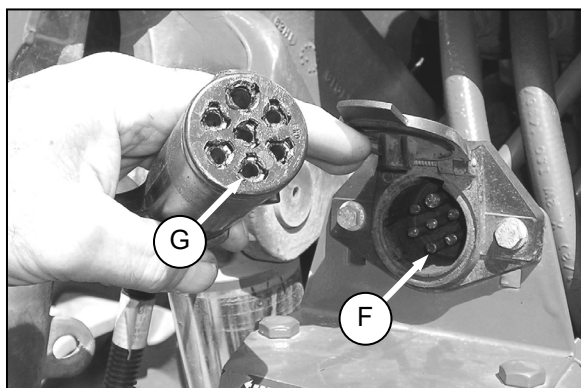

IMPORTANT

Older model tractors will have Pin #4 (F) energized as an accessory circuit. The mower conditioner uses this pin position (G) for brake lights. Check that Pin #4 in the tractor receptacle is not constantly energized - see tractor's Operator's Manual, and remove the appropriate fuse (if required).

UNLOADING AND ASSEMBLY

STEP 14. INSTALL STEERING CYLINDER

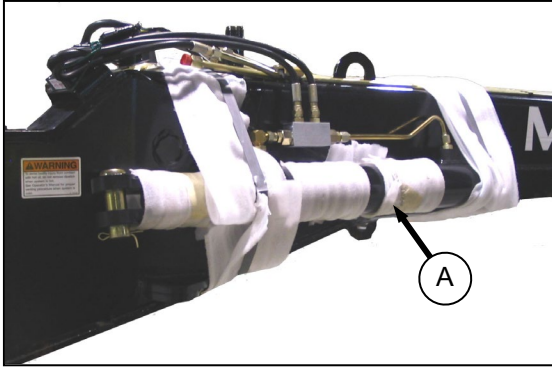

- a. Cut the banding that secures the cylinder (A) to the APT, and remove all shipping material.



CAUTION

Hold cylinder to stop it from falling when the bands are cut.

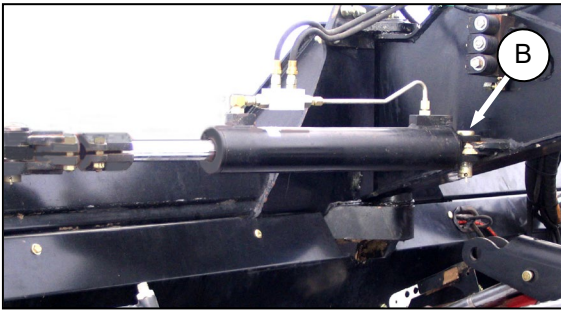

- b. Attach the barrel end to bracket on the APT with pin (B) as shown. Secure with cotter pin. Do not attach rod end.



IMPORTANT

To allow APT to swing, the valve on the APT must be in the working or "open" position (handle in line with APT).



DANGER

Never start or move the machine until you are sure all bystanders have cleared the area.

- c. Start tractor.
- d. Stroke the cylinder to full extension and retraction 3 or 4 times to ensure that cylinder and hydraulic lines are fully charged with oil.

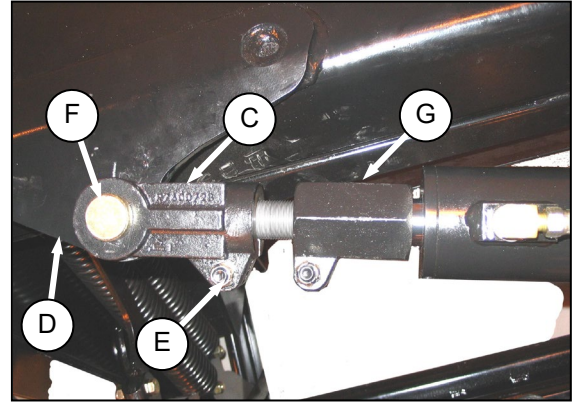

- e. Stroke the cylinder so that the clevis (C) can be slipped onto the bracket (D) on the frame. Do not install pin (F) at this time.



CAUTION

Stop engine, and remove key from ignition before leaving Operator's seat for any reason. A child or even a pet could engage an idling machine.

- f. Shutdown the tractor, and remove the key.
- g. Loosen clamping bolt (E) on clevis (C).
- h. Using a wrench on the stroke control (G), rotate cylinder rod so that holes in clevis and frame "line up", and pin (F) can be installed. Secure pin with cotter pin.

(continued next page)

UNLOADING AND ASSEMBLY

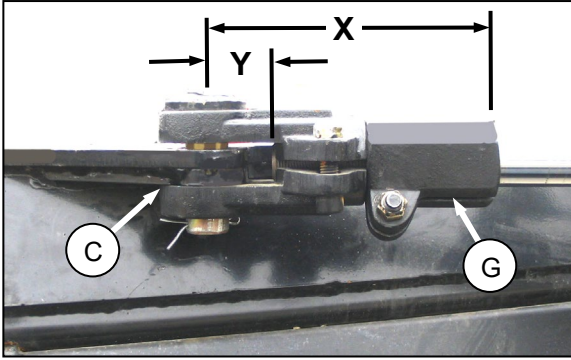

- i. Rotate cylinder rod with wrench on stroke control (G) to dimension 'Y' in following chart.
- j. Tighten clamping bolt on clevis (C).
- k. Loosen clamping bolt on stroke control (G) and rotate stroke control to dimension 'X' in the following table:

MODEL	DIM. 'X' in. (mm)	DIM. 'Y' in. (mm)
14 FT	8.70 (221)	1.97 (50)
16 and 18 FT	8.23 (209)	2.48 (63)

- l. Tighten clamping bolt to 65 ft·lbf (90 N·m).

NOTE

Dimensions 'X' and 'Y' may require additional adjustments to obtain correct tracking of unit to suit field conditions.

Each turn of the stroke control changes the tracking by approximately 2 in. (51 mm).

UNLOADING AND ASSEMBLY

STEP 15. INSTALL ROLL OPENER LINKS

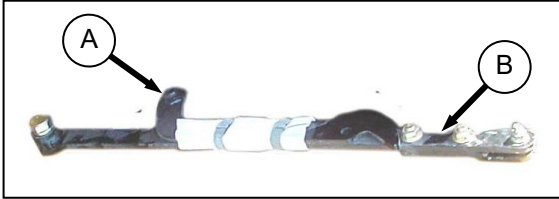

- a. Remove banding securing conditioner roll opener arm (A) to rear link (B).

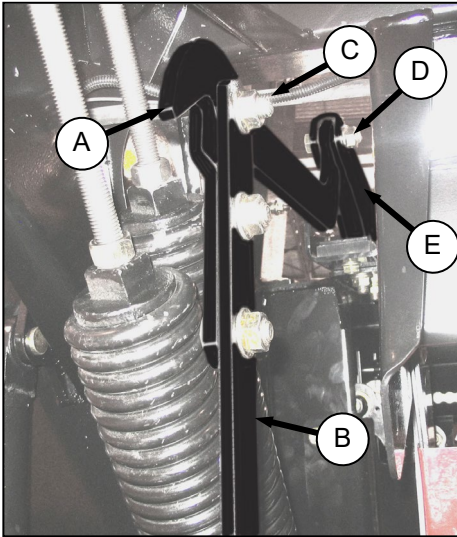

LOOKING FORWARD AT LH LINK
RH OPPOSITE

- b. Attach head (hook end) of roll opener arm (A) to rear link (B) with bolt (C) that was removed in STEP 8a. Do not over-tighten locknut. Links must pivot freely at (C).

IMPORTANT

Joggle in rear links (B) must face outboard.

- c. Remove bolt (D) from roll lift arm (E) on header, and attach **ball joint end** of opener arm at this location. Tighten securely.

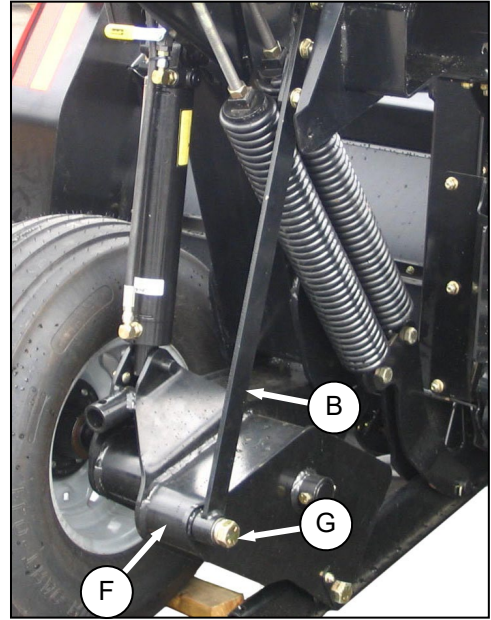

- d. Attach lower end of rear link (B) to arm (F) with bolt (G) that was removed in STEP 8a. Torque to 150 ft·lbf (203 N·m).
- e. Repeat above steps for opposite side.

UNLOADING AND ASSEMBLY

STEP 16. INSTALL FORMING SHIELD COVER

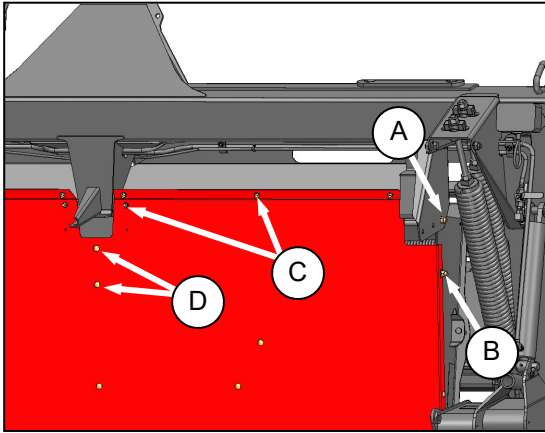

- Loosen carriage bolt (A) securing forming shield to frame at each side of shield.
- Remove two ½ in. x 1.25 carriage bolts (B) from each side of forming shield, and retain for re-installation.
- Remove eight 3/8 in. x .75 bolts (C) along top of shield, and two (D) bolts at center that will be used to secure shield to frame once it is in place.

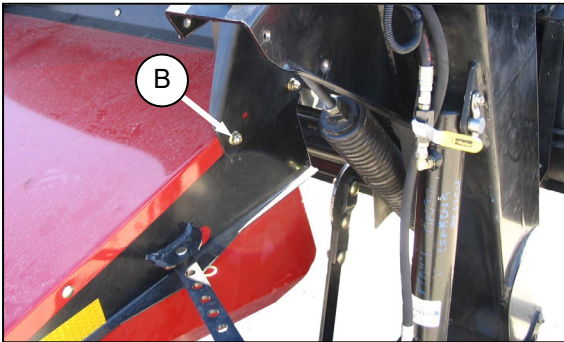

- Swing forming shield into position, and support it so that the ½ in. x 1.25 carriage bolts (B) can be re-installed. Bolt heads to be facing inboard. Leave bolts loose.

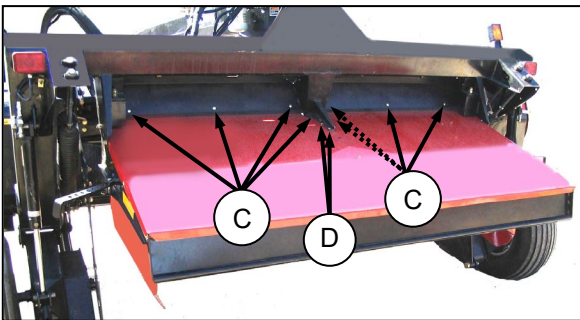

- Install two 3/8 in. x .75 carriage bolts (D) at center support.
- Fasten forming shield to frame with 3/8 in. x .75 carriage bolts (C) and serrated nuts at eight places.
- Tighten all hardware.

STEP 17. INSTALL SIDE DEFLECTORS

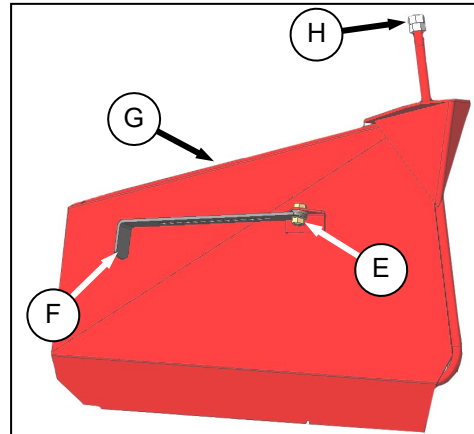

- Remove bolt (E), washers, and nut that attaches adjuster bar (F) to side deflector (G). Note location of washers relative to adjuster bar. Retain hardware.

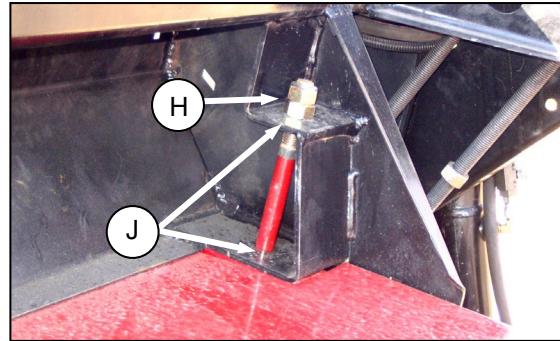

- Remove nuts (H) from support rod.
- Install each side deflector support rod through frame at (J), and secure with ¾ in. hex nuts (H). Hardware (H) must be tight enough to hold deflectors in position, but still allow positioning with adjuster bars.

NOTE

Swing deflector to inboard position to assist installation.

- If forming shield side deflectors are too loose, or if they bind when moved with adjuster bars, back off top nut at (H), and adjust lower nut at (H) as required. Then, holding lower nut with a wrench, tighten top nut securely against lower nut.

(continued next page)

UNLOADING AND ASSEMBLY

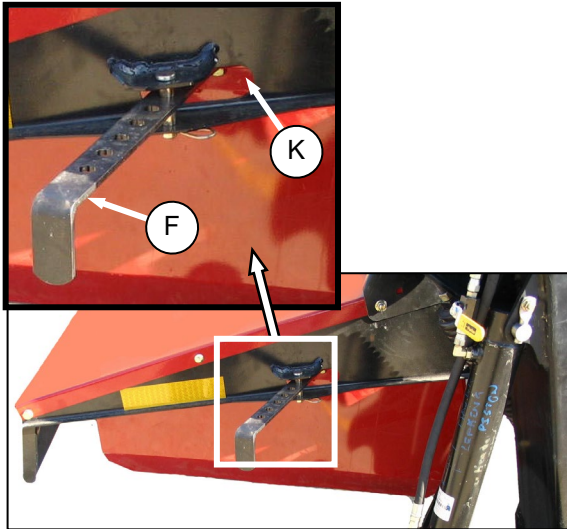

- e. Locate adjuster bars (F) through openings (K) in forming shield.

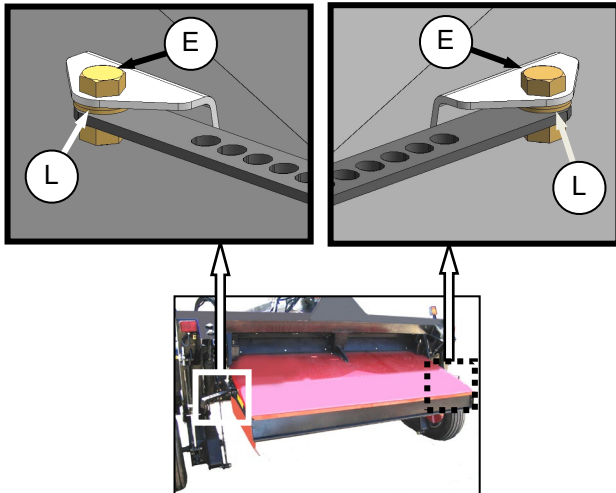

- f. Secure bars (F) to brackets on side deflectors with bolts (E), washers (L), and nuts.

IMPORTANT

To avoid binding with deflectors at full outboard position, bar (F) and washers (L) must be re-installed exactly as shown.

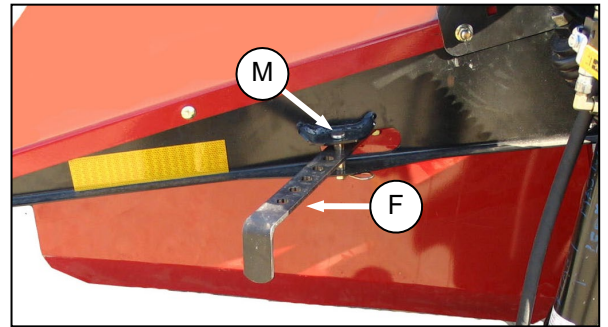

- g. Secure each adjuster bar (F) to forming shield with pin (M) and hairpin. Use same hole location on both sides.

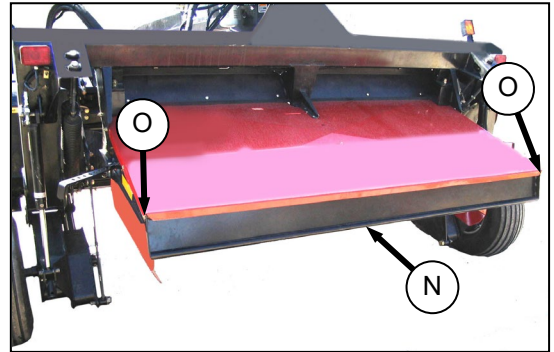

- h. Adjust fluffer shield (N) to middle position. Loosen bolts (O) if required.

UNLOADING AND ASSEMBLY

STEP 18. ADJUST CENTER LINK

A. MECHANICAL LINK

- Lower header so that cutter bar is resting on the ground. Stop engine, and remove key.



CAUTION

Stop engine, and remove key from ignition before leaving Operator's seat for any reason. A child or even a pet could engage an idling machine.

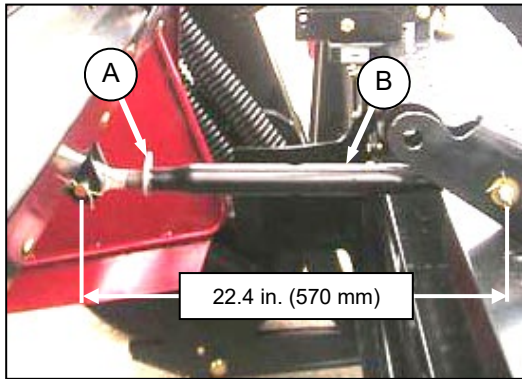

- Loosen nut (A).
- Rotate the turnbuckle sleeve (B) to obtain 22.4 inches (570 mm) dimension.
- Snug up nut (A), but do not over-tighten. A slight tap with a small hammer is sufficient.

B. HYDRAULIC LINK

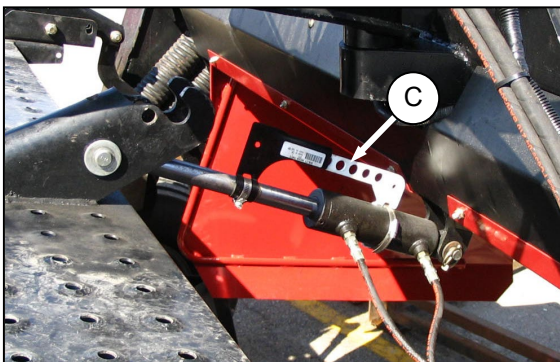

- Operate tractor hydraulic control so that gauge (C) is approximately at the middle hole.

STEP 19. ADJUST FLOAT SPRINGS

The float springs were factory set to provide the minimum width for shipping, and need to be re-adjusted prior to use.



CAUTION

To prevent damage to front panel on carrier frame, do not raise header with lift cylinders before backing off float spring drawbolts.

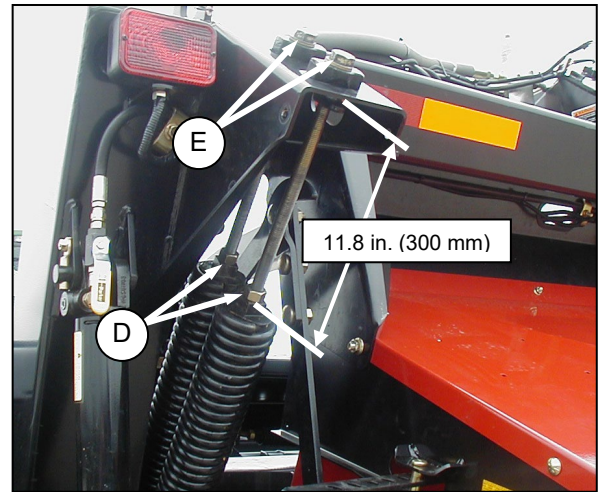

- Unlock jam-nuts (D) from float springs.
- Turn drawbolts (E) counter clockwise to release spring tension to 11.8 inches (300 mm) dimension shown. There are two springs on each side to adjust.



CAUTION

To prevent damage to the float spring system, do not lower the header before tightening jam nuts (A) against the springs.

IMPORTANT

Because header weight transfers to outside tire whenever header is swung from one side to the other, tires must be fully inflated (30 psi (207 kPa)) to minimize effects on header float.

- Lift either end of the header "just" off the ground. Header flotation springs are normally set so 70 lbf (311 N) force is required to lift the header.
- Adjust springs as required.
- Tighten jam nuts (D) against float springs.

UNLOADING AND ASSEMBLY

STEP 20. REPOSITION WOBBLE BOX BREATHER

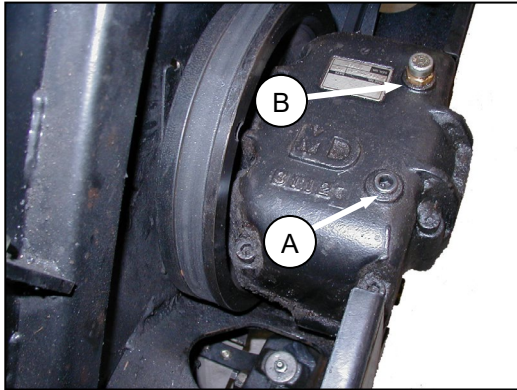

- Move breather (B) to back port and install plug (A) in forward port at wobble box(es).

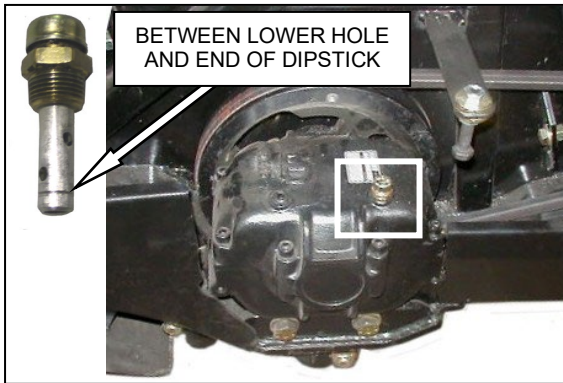

CHECK OIL LEVEL WITH TOP OF WOBBLE BOX HORIZONTAL

- Check oil level.

STEP 21. ADJUST LEAN BAR

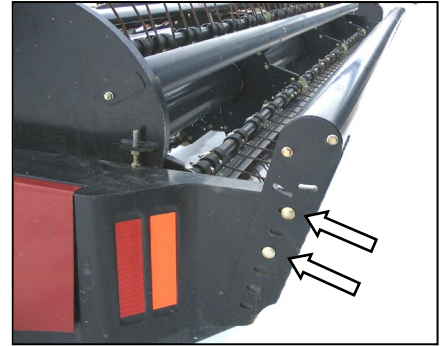

Lean bar is fully retracted for shipping. Remove hardware on both sides, and install lean bar in field position at position suitable for crop (normally 2/3 of crop height).

NOTE

If optional tall crop divider kit is supplied, it can be installed prior to re-installing the lean bar. See STEP 23E. TALL CROP DIVIDER KIT.

STEP 22. ADJUST TRANSPORT LIGHTS

- Position amber light supports perpendicular to header.

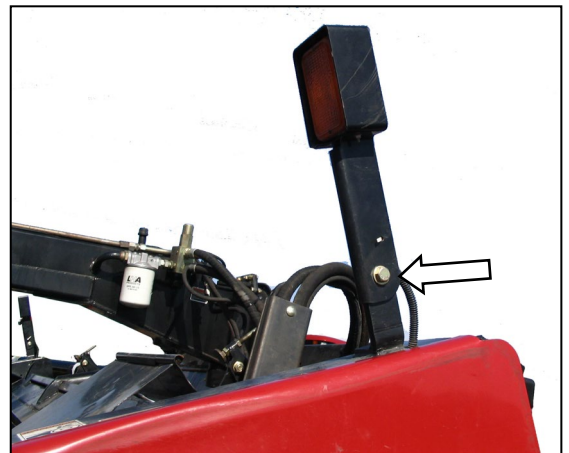

- Check that pivot bolt is tight enough to hold light support in upright position, yet allow light to pivot out of the way of obstructions.

NOTE

Do not over-tighten mounting hardware.

- Ensure base of light housings and bolted connections on light supports provide proper electrical grounding.

UNLOADING AND ASSEMBLY

STEP 23. INSTALL OPTIONS

A. GAUGE ROLLERS

- a. Unpack gauge roller bundle.

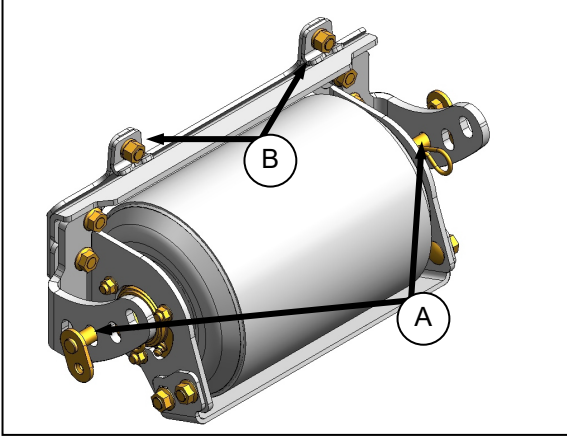

- b. Remove two locking pins (A) from each assembly.
c. Remove nuts, bolts, and clips (B) from assembly.

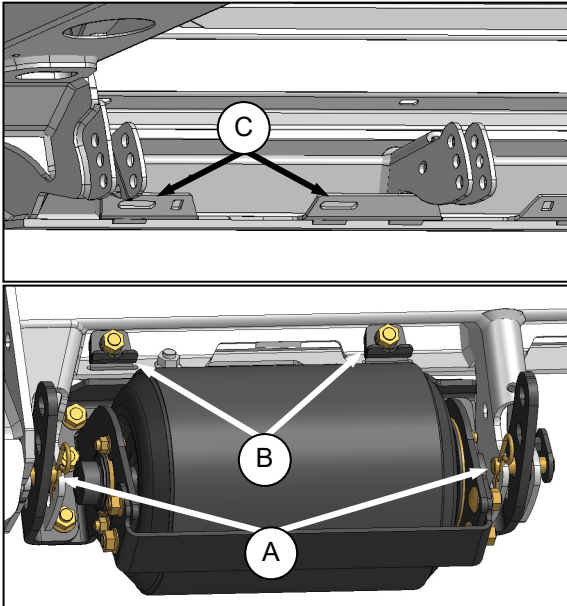

- d. Insert tabs on roller assembly into slots (C) on cutterbar at outboard mounting locations on frame, and secure to support bracket with locking pin (A) at lowest position.

- e. Attach clips (B) with bolts and nuts removed at step c. to secure roller assembly to cutterbar.
f. Tighten nuts.

NOTE

Use a socket and ratchet wrench to access the nuts.

- g. Remove locking pin (A), and adjust rollers to desired height. Re-install both locking pins (A).

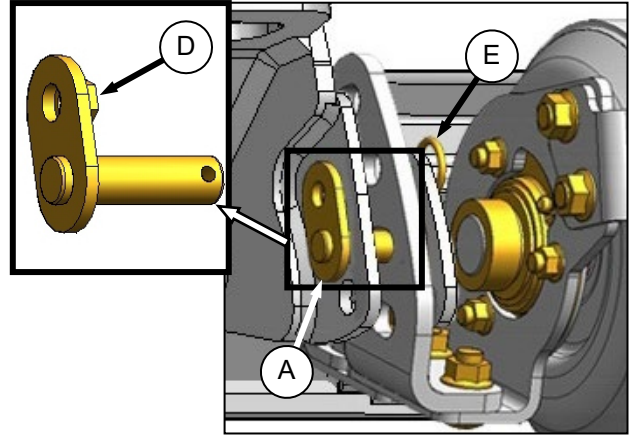

- h. Ensure that nut (D) on each pin registers in adjacent hole in support bracket.
i. Secure pins with hairpins (E).
j. Repeat above steps for opposite side. Set both gauge rollers to same position.

UNLOADING AND ASSEMBLY

B. SKID SHOES

- a. Unpack skid shoe bundle.

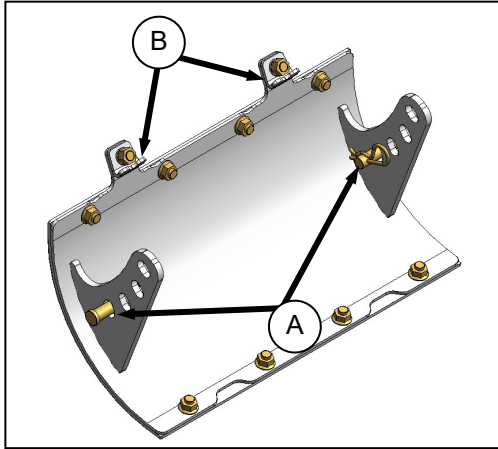

- b. Remove two clevis pins (A) from each skid shoe.
c. Remove nuts, bolts, and clips (B) from skid shoe.

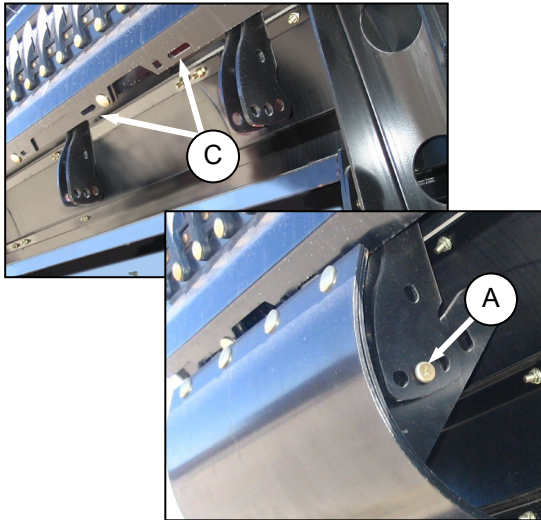

- d. Position skid shoe below cutterbar, and insert tabs on skid shoe into slots (C) in frame. Secure with clevis pin (A).

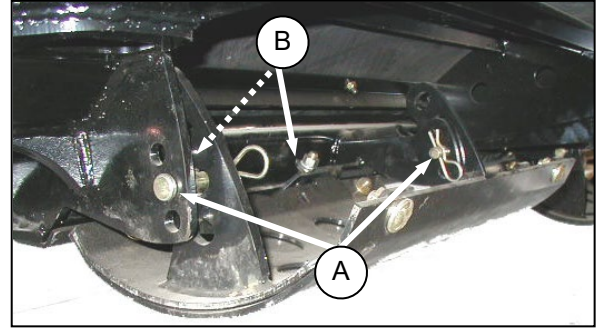

- e. Attach clips (B) with bolts and nuts removed at step c. to secure skid shoe to cutterbar.

NOTE

Use a socket and ratchet wrench to access the nuts.

- f. Tighten nuts.
g. Remove clevis pin (A), and adjust skid shoe to desired height. Re-install two clevis pins (A), and secure with lynch pins.
h. Repeat above steps for opposite side. Set both skid shoes to same position.

C. STUB GUARDS

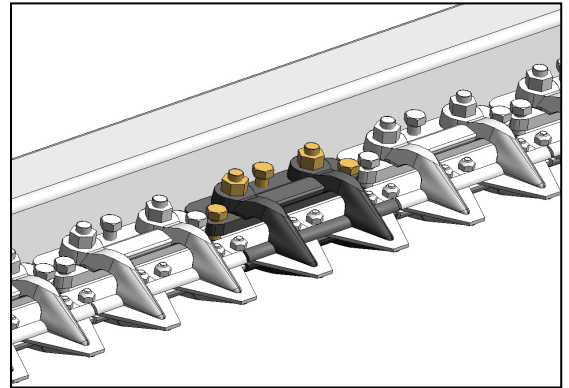

Refer to installation and adjustment instructions in the kit.

UNLOADING AND ASSEMBLY

D. HYDRAULIC HEADER ANGLE

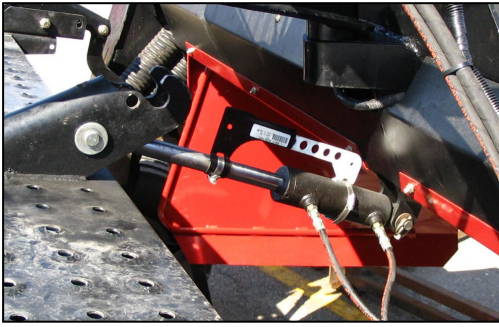

Refer to installation and adjustment instructions in the kit.

E. TALL CROP DIVIDER KIT

- Unpack kit, and disassemble hardware from divider.
- Remove lean bar from header.

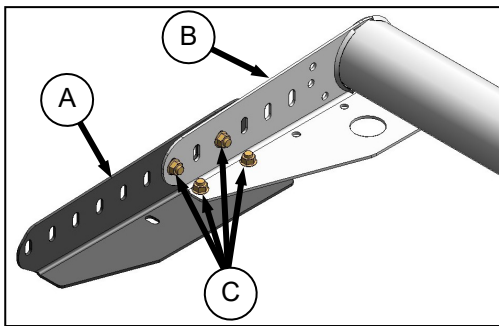

- Attach extension angles (A) to each end of lean bar (B) with four 1/2 x 1.0 in. hex bolts (C) and nuts provided.
- Re-install lean bar on header with existing hardware. Tighten bolts.

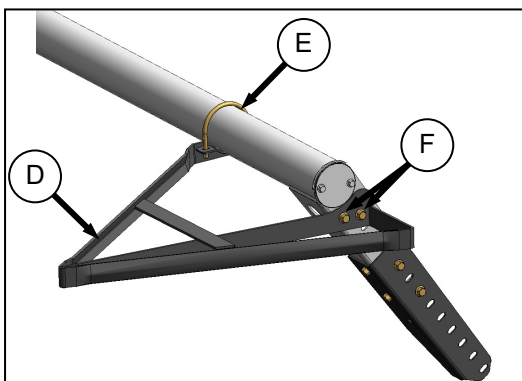

- Position LH divider (D) at LH side of lean bar, and attach with U-bolt (E), two 3/8 nuts, and two 1/2 x 1.0 in. hex bolts (F) and nuts provided.
- Adjust to desired position, and tighten hardware.
- Repeat steps e. and f. for RH side.

UNLOADING AND ASSEMBLY

STEP 24. LUBRICATE THE MOWER CONDITIONER



WARNING

To avoid bodily injury or death from unexpected start-up or fall of raised machine, stop engine, remove key and engage lift cylinder stops before going under machine for any reason.

The mower conditioner has been lubricated at the factory. However, it is recommended to lubricate the mower conditioner prior to delivery to offset the effects of weather during outside storage and transport, and to familiarize the Dealer with the machine.

Refer to the following table and illustrations on the following pages for lubrication points.

- Wipe grease fitting with a clean cloth before greasing, to avoid injecting dirt and grit.
- Inject grease through fitting with grease gun until grease overflows fitting, except where noted.
- Leave excess grease on fitting to keep out dirt.
- Replace any loose or broken fittings immediately.
- If fitting will not take grease, remove and clean thoroughly. Also clean lubricant passageway. Replace fitting if necessary.

MODEL	APPLICABLE PAGE NUMBERS			
	HEADER DRIVE	HAY CONDITIONER	CARRIER	APT
A30-S	36 - 37	40	42	43
A30-D	38 - 39	41		

PRE-DELIVERY CHECKS

A. HEADER DRIVE: A30-S

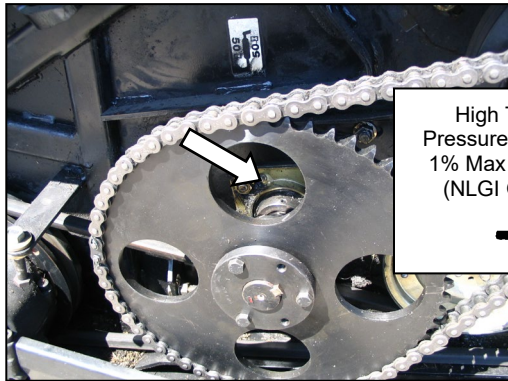

AUGER SHAFT BEARING (1 PLC)

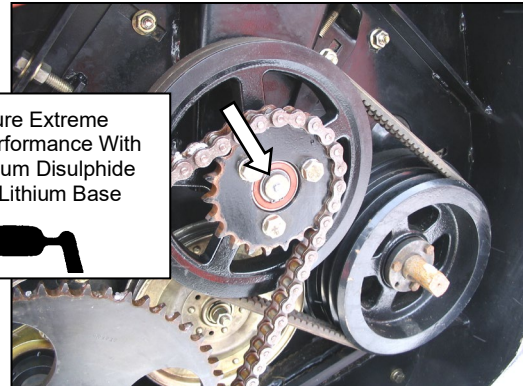

AUGER DRIVE BEARING (1 PLC)

High Temperature Extreme Pressure (EP2) Performance With 1% Max Molybdenum Disulphide (NLGI Grade 2) Lithium Base

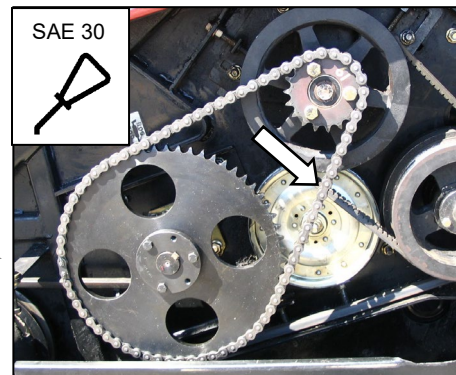
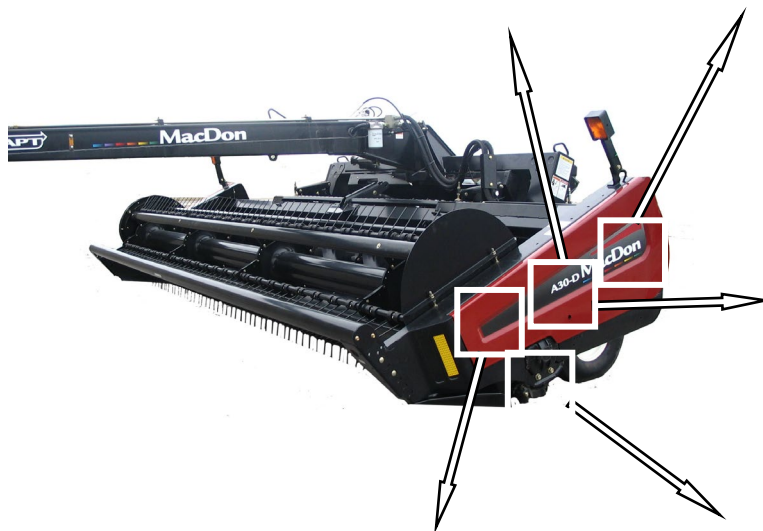
AUGER DRIVE CHAIN (1 PLC)

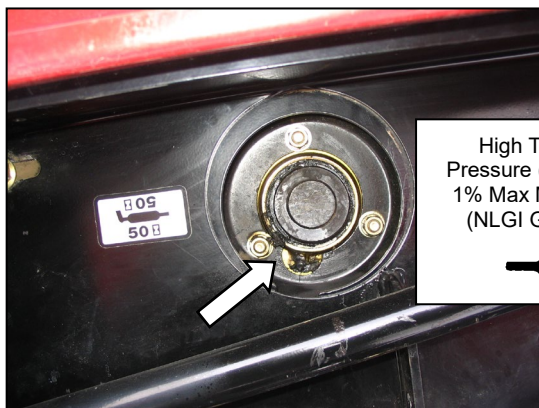

REEL SHAFT BEARING (1 PLC)

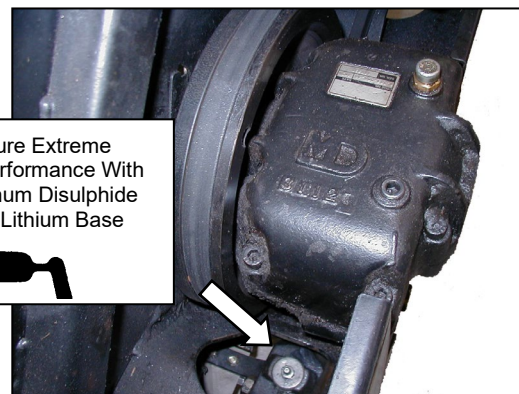

SICKLE HEAD BEARING (1 PLC)

High Temperature Extreme Pressure (EP2) Performance With 1% Max Molybdenum Disulphide (NLGI Grade 2) Lithium Base





NOTE

To prevent binding and/or excessive wear caused by sickle pressing on guards, do not over grease. If more than 6 to 8 pumps of the grease gun are required to fill the cavity, replace the seal in the sickle head.

PRE-DELIVERY CHECKS

B. HEADER DRIVE: A30-S

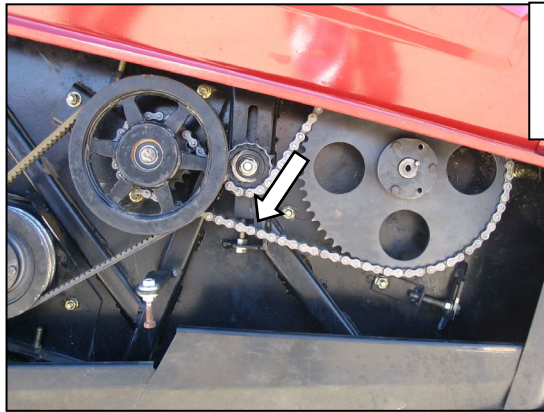
High Temperature Extreme Pressure (EP2) Performance With 1% Max Molybdenum Disulphide (NLGI Grade 2) Lithium Base



REEL DRIVE CHAIN (1 PLC)

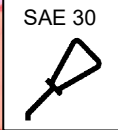

OIL KNIFE DAILY EXCEPT IN SANDY SOIL

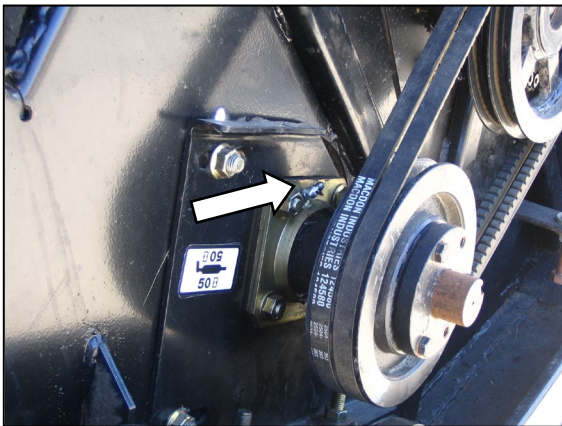

AUGER SHAFT BEARING (1 PLC)

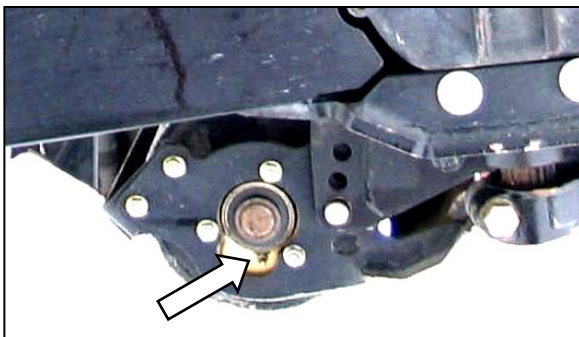
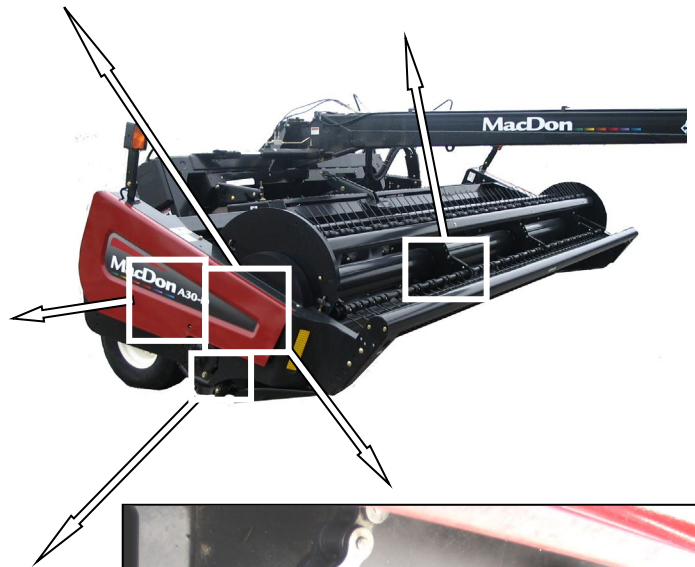

GAUGE ROLLER BEARINGS (2 PLCS)
- BOTH SIDES

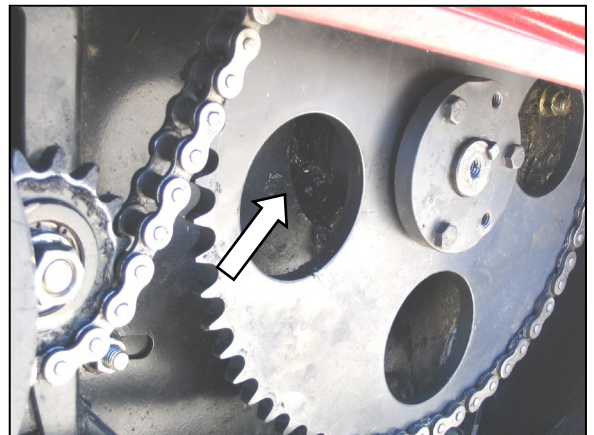

REEL SHAFT BEARING (1 PLC)

PRE-DELIVERY CHECKS

C. HEADER DRIVE: A30-D

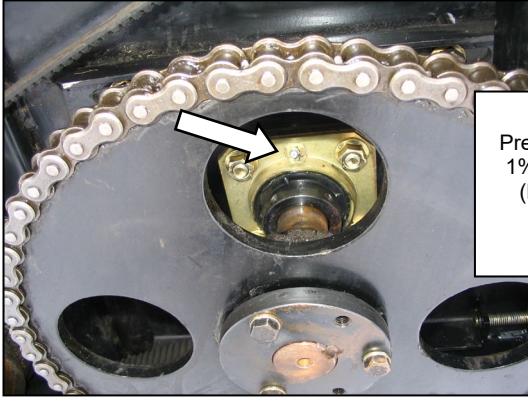

AUGER SHAFT BEARING (1 PLC)

High Temperature Extreme Pressure (EP2) Performance With 1% Max Molybdenum Disulphide (NLGI Grade 2) Lithium Base

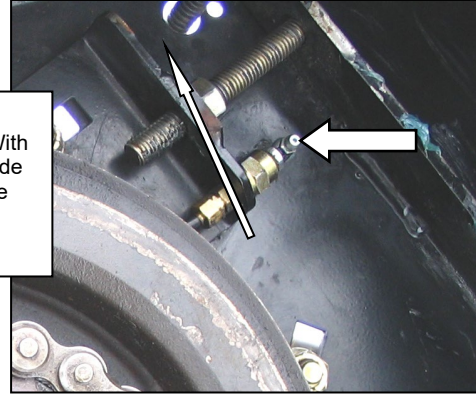
CROSS SHAFT BEARING (1 PLC)

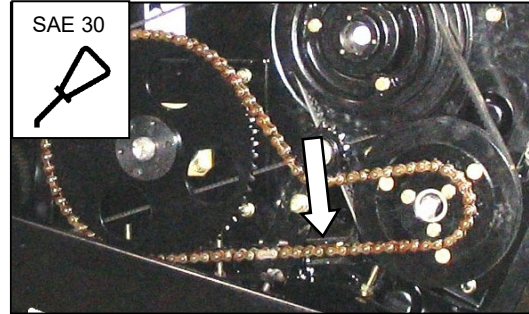
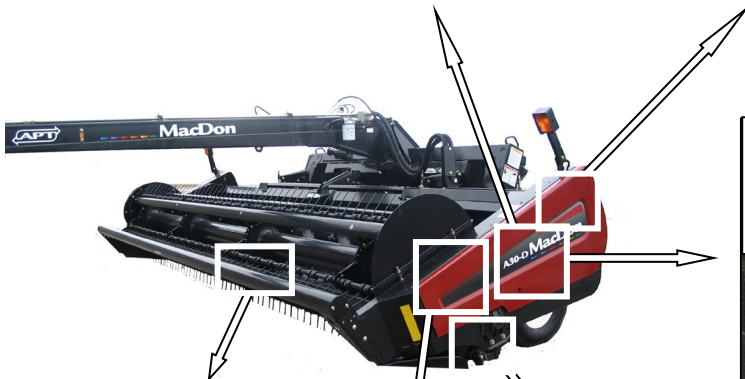

AUGER DRIVE CHAIN (1 PLC)



OIL KNIFE DAILY EXCEPT IN SANDY SOIL

High Temperature Extreme Pressure (EP2) Performance With 1% Max Molybdenum Disulphide (NLGI Grade 2) Lithium Base

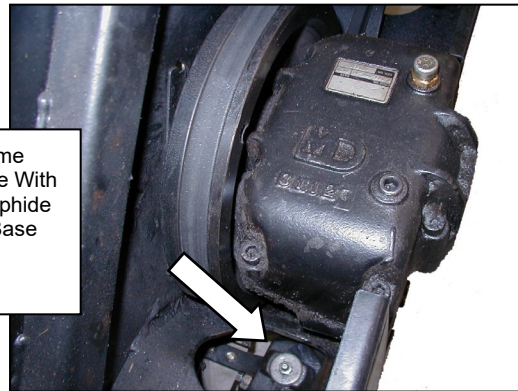
SICKLE HEAD BEARING (1 PLC)



REEL SHAFT BEARING (1 PLC)

NOTE

To prevent binding and/or excessive wear caused by sickle pressing on guards, do not over grease. If more than 6 to 8 pumps of the grease gun are required to fill the cavity, replace the seal in the sickle head.

PRE-DELIVERY CHECKS

D. HEADER DRIVE: A30-D

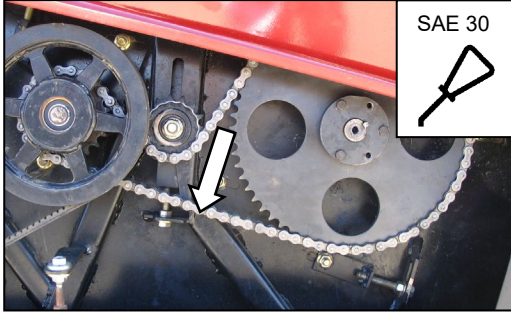

REEL DRIVE CHAIN (1 PLC)

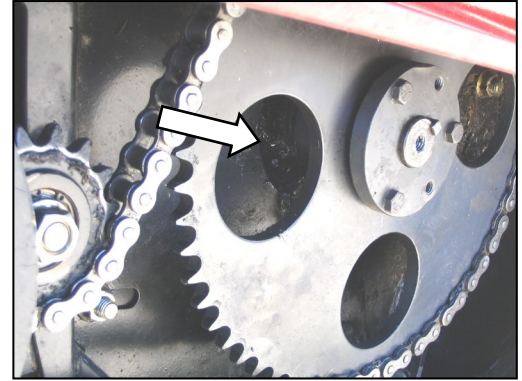

REEL SHAFT BEARING (1 PLC)

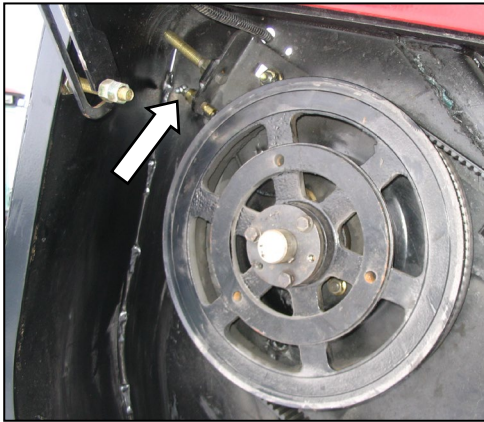

SICKLE DRIVE BEARING (1 PLC)

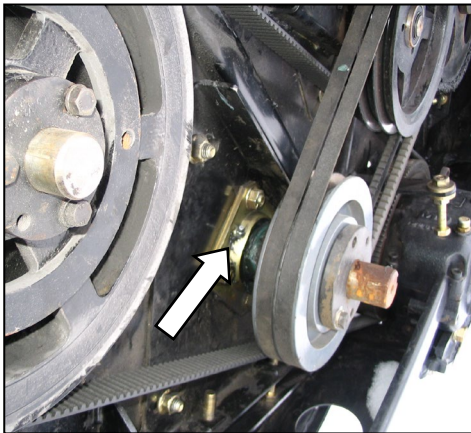

AUGER SHAFT BEARING (1 PLC)

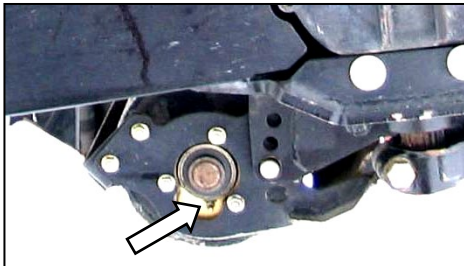

GAUGE ROLLER BEARINGS (2 PLCS)
- BOTH SIDES

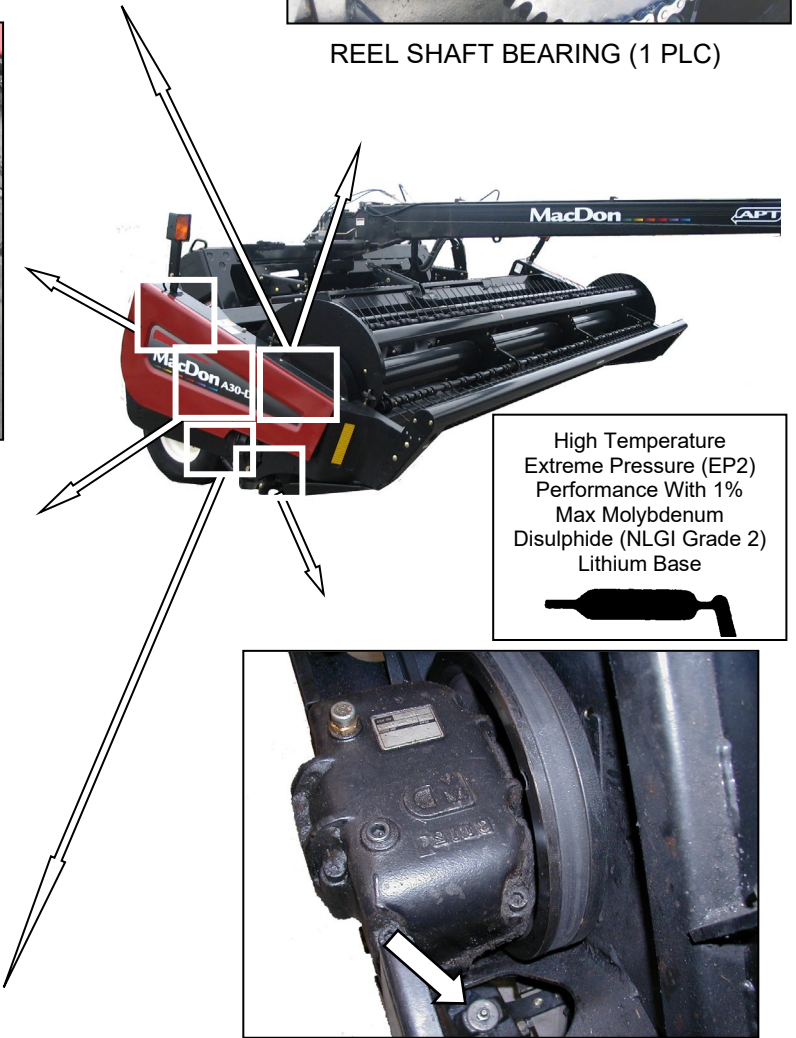

SICKLE HEAD BEARING (1 PLC)

NOTE

To prevent binding and/or excessive wear caused by sickle pressing on guards, do not over grease. If more than 6 to 8 pumps of the grease gun are required to fill the cavity, replace the seal in the sickle head.

PRE-DELIVERY CHECKS

E. HAY CONDITIONER: A30-S

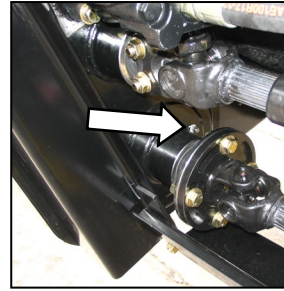

GEARBOX OIL LEVEL WITH HEADER IN WORKING POSITION
- OIL RUNS OUT OF CHECK PLUG

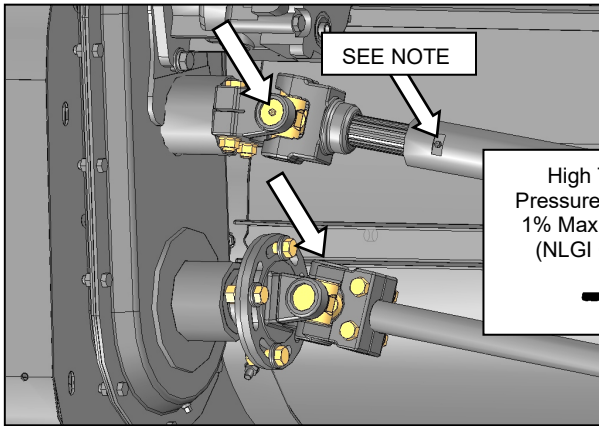

DRIVELINE UNIVERSALS (2 PLCS)
DRIVELINE SHAFTS (1 PLC)

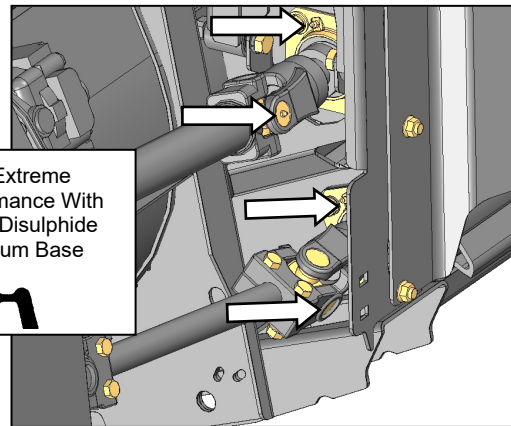

DRIVELINE UNIVERSALS (2 PLCS)
ROLL SHAFT BEARINGS (2 PLCS)

High Temperature Extreme Pressure (EP2) Performance With 1% Max Molybdenum Disulphide (NLGI Grade 2) Lithium Base

NOTE
10% MOLY GREASE IS RECOMMENDED FOR DRIVELINE SHAFT SLIP JOINTS ONLY.

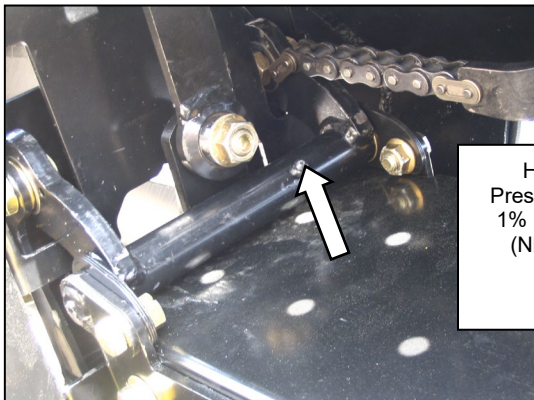

ROLL PIVOT (1 PLC BOTH SIDES)

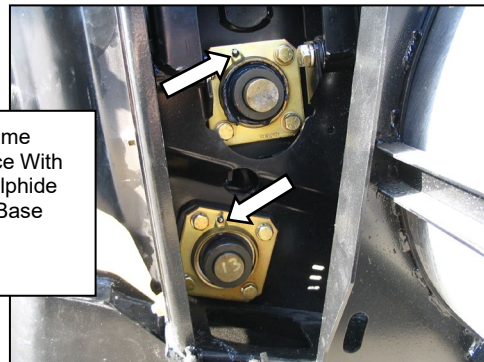

ROLL SHAFT BEARINGS (2 PLCS)

High Temperature Extreme Pressure (EP2) Performance With 1% Max Molybdenum Disulphide (NLGI Grade 2) Lithium Base

PRE-DELIVERY CHECKS

F. HAY CONDITIONER: A30-D

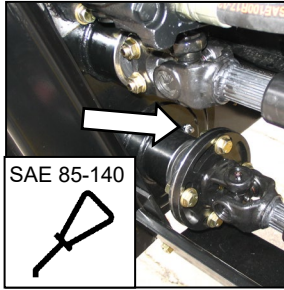

GEARBOX OIL LEVEL WITH HEADER IN WORKING POSITION
- OIL RUNS OUT OF CHECK PLUG

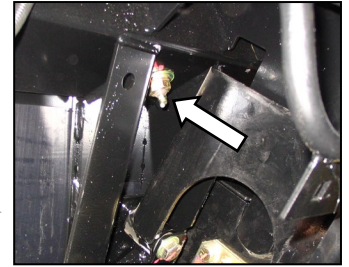

CROSS SHAFT (1 PLC)

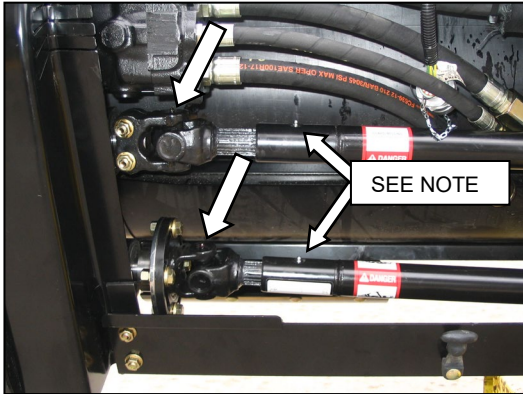

DRIVELINE UNIVERSALS (2 PLCS)
DRIVELINE SHAFTS (2 PLCS)

High Temperature Extreme Pressure (EP2) Performance With 1% Max Molybdenum Disulphide (NLGI Grade 2) Lithium Base

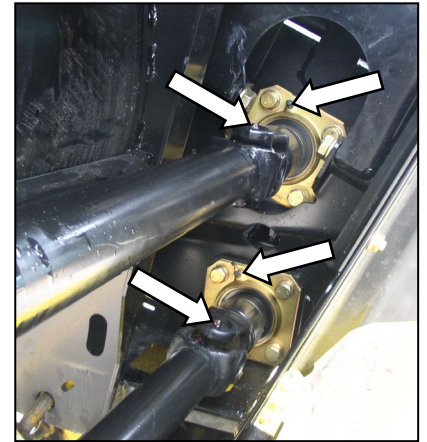

DRIVELINE UNIVERSALS (2 PLCS)
ROLL SHAFT BEARINGS (2 PLCS)

NOTE
10% MOLY GREASE IS RECOMMENDED FOR DRIVELINE SHAFT SLIP JOINTS ONLY.

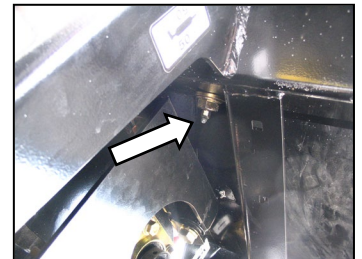

CROSS SHAFT (1 PLC)

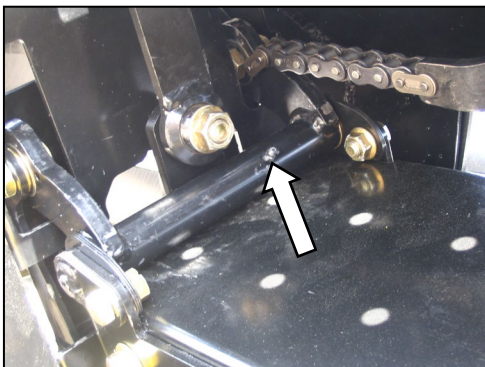

ROLL PIVOT (1 PLC BOTH SIDES)

High Temperature Extreme Pressure (EP2) Performance With 1% Max Molybdenum Disulphide (NLGI Grade 2) Lithium Base

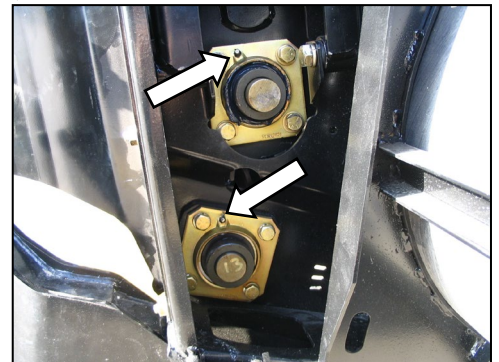

ROLL SHAFT BEARINGS (2 PLCS)

PRE-DELIVERY CHECKS

G. CARRIER

High Temperature Extreme Pressure (EP2) Performance With 1% Max Molybdenum Disulphide (NLGI Grade 2) Lithium Base

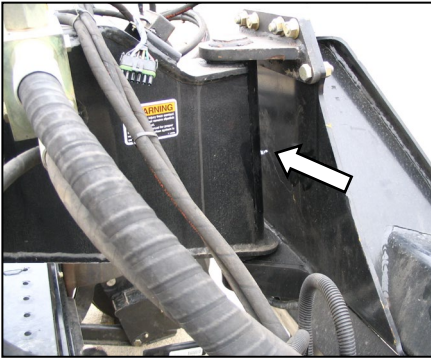

HITCH PIVOT (1 PLC)

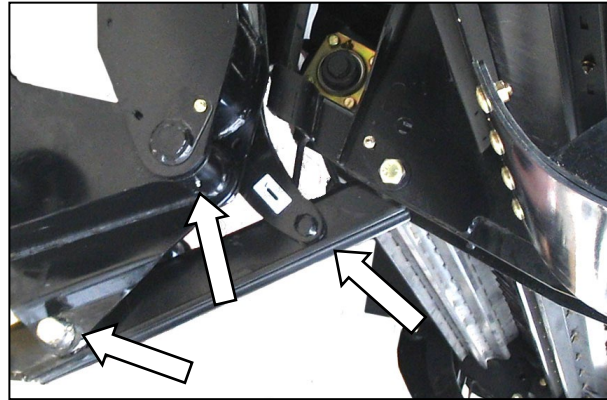

FLOAT LINK (3 PLCS) BOTH SIDES

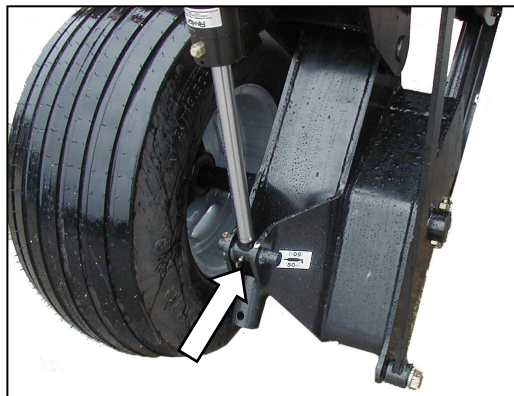

LIFT CYL ATTACH
(1 PLC LH SIDE)



WHEEL BEARINGS
(1 PLC BOTH SIDES)

PRE-DELIVERY CHECKS

H. ARTICULATING POWER TONGUE (APT)

High Temperature Extreme Pressure (EP2) Performance With 1% Max Molybdenum Disulphide (NLGI Grade 2) Lithium Base



APT SWIVEL

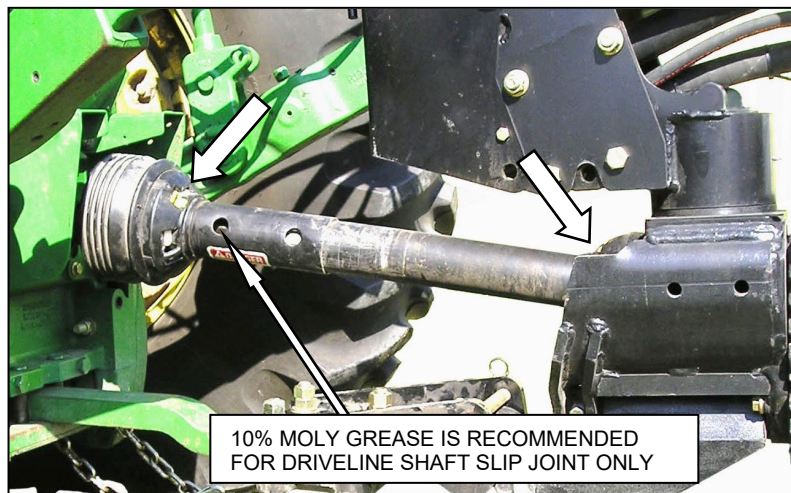

APT DRIVELINE

PRE-DELIVERY CHECKS

STEP 25. PERFORM PRE-DELIVERY CHECKS



WARNING

Stop tractor engine, and remove key before making adjustments to machine. A child or even a pet could engage the drive.

IMPORTANT

To avoid machine damage, check that no shipping dunnage has fallen into cutterbar.

- a. Perform the final checks and adjustments as listed on the "Pre-Delivery Checklist" (yellow sheet attached to back of this instruction) to ensure the machine is field-ready. Refer to the pages for detailed instructions as indicated on the checklist.
- b. The completed checklist should be retained either by the Operator or the Dealer.

NOTE

The majority of checks and adjustments are performed during the set-up procedures. The following additional inspections should be performed after the set-up is complete.

A. DRIVE BELTS AND CHAINS

- a. Drive belt and chain tensions have been properly set at the factory, and should not require any further adjustment.

Check as shown, depending on the model.

I. A30-S SINGLE KNIFE

- a. Open shield on header RH side.

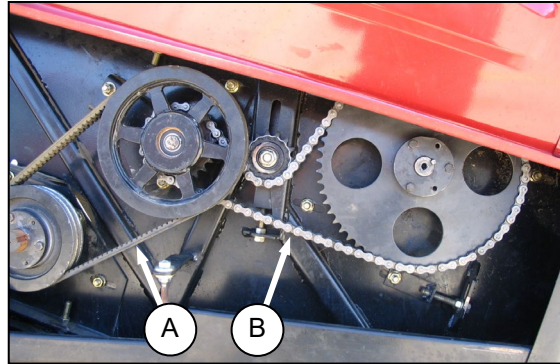

- b. Reel drive belts (A) should deflect 3/16 in. (4 mm) when a load of 8 - 12 lbf (35 - 40 N) is applied to each belt at mid-span.
- c. Reel drive chain (B) slack should be 1/4 in. (6 mm).
- d. Close shield.
- e. Open shield on header LH side.

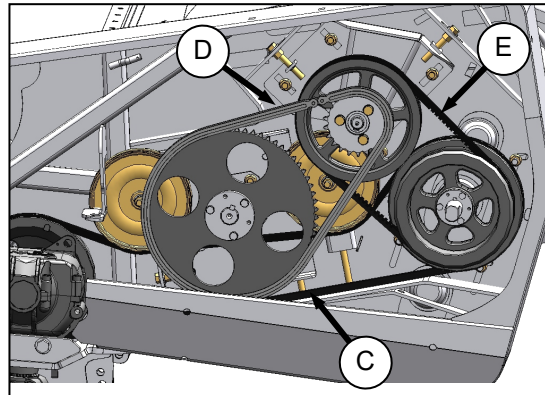

- f. Sickle drive belt (C) should deflect 1/4 in. (6 mm) when a load of 20 lbf (80 N) is applied at mid-span).
- g. Auger drive chain (D) deflection at midspan should be 1/4 in. (6 mm).
- h. Auger drive belts (E) should deflect 3/16 in. (4 mm) when a load of 8 - 12 lbf (35 - 40 N) is applied to each belt at mid-span.
- i. Close shield.
- j. Proceed to Section 25B. AUGER STRIPPER BAR CLEARANCE.

PRE-DELIVERY CHECKS

II. A30-D DOUBLE KNIFE

- a. Open shield on header RH side.

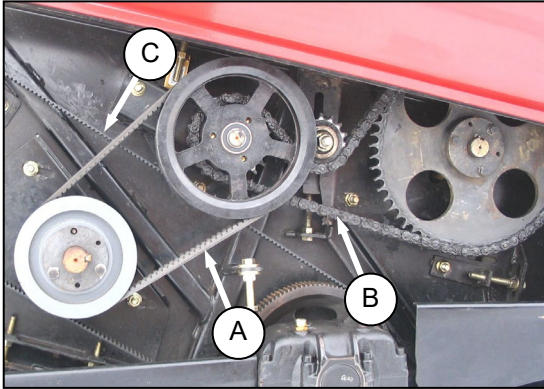

- b. **Reel drive belt (A)** should deflect 3/16 in. (4 mm) when a load of 8 - 12 lbf (35 - 40 N) is applied to each belt at mid-span.
- c. **Reel drive chain (B)** slack should be 1/4 in. (6 mm).
- d. **Sickle drive belt (C)** should deflect 0.55 in. (14 mm) when a load of 5 - 6.5 lbf (22 - 30 N) is applied at mid-span).
- e. Close shield.
- f. Open shield on header LH side.

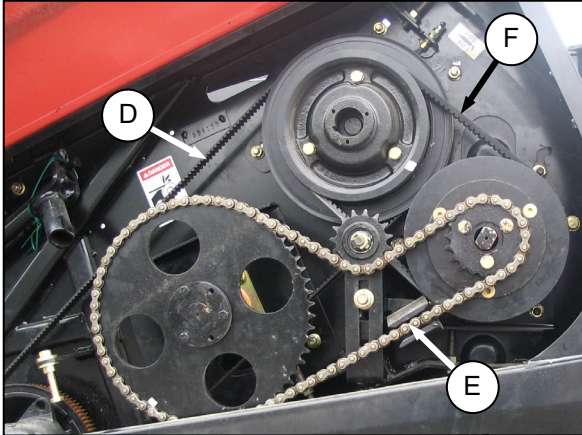

- g. **Sickle drive belt (D)** should deflect 0.55 in. (14 mm) when a load of 5 - 6.5 lbf (22 - 30 N) is applied at mid-span).
- h. **Auger drive chain (E)** deflection should be 1/4 in. (6 mm).
- i. **Auger drive belts (F)** should deflect 3/16 in. (4 mm) when a load of 8 - 12 lbf (35 - 40 N) is applied to each belt at mid-span.
- j. Close shield.

PRE-DELIVERY CHECKS

B. AUGER STRIPPER BAR CLEARANCE

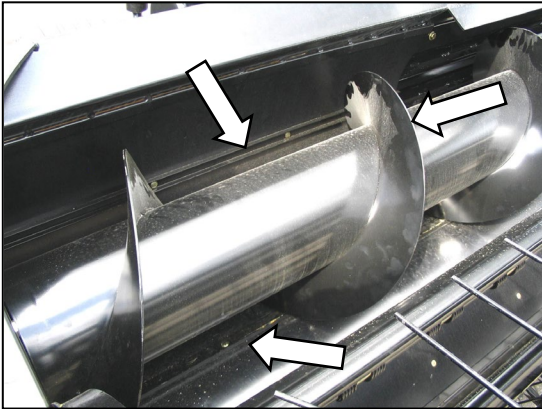

- a. Check for signs of auger flighting rubbing stripper bars after run-up.

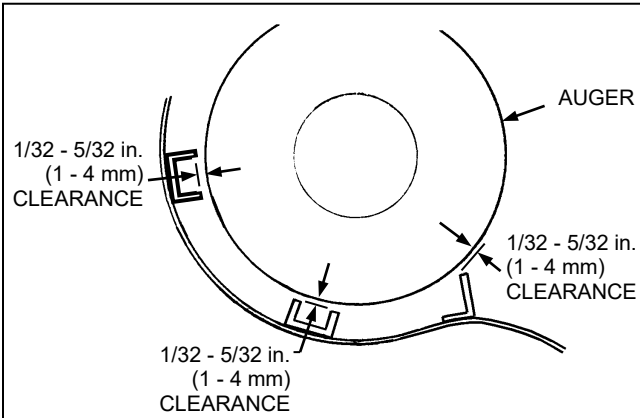

- b. Check clearance between auger flighting and stripper bars.

NOTE

The auger should clear the stripper bars on the auger pan by approximately 1/32 - 5/32 in. (1 - 4 mm). Shimming the stripper bars may be required.

C. REEL TINE TO HEADER PAN CLEARANCE

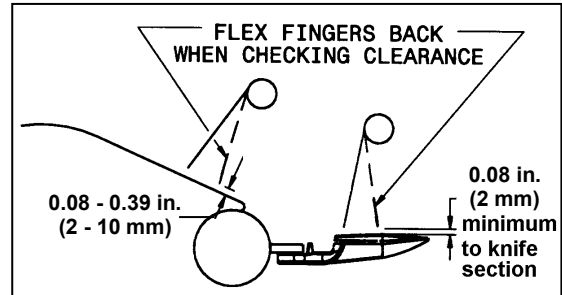

IMPORTANT

The above dimensions are provided as guidelines only. Tines may "slightly" contact the guards, but not the knife sections or the auger pan.

- a. Rotate reel slowly by hand, and check tine clearance at knife and pan. Flex tines to simulate crop-loaded position to ensure tine clearances to knife sections and auger pan are adequate for working conditions.
- b. Check that the reel rotates freely.

NOTE

In order to set the reel as close as possible to the knife and pan, it may be necessary to trim a small number of tines that appear exceptionally long.

D. HEADER FLOTATION

- a. Position header directly behind tractor, and lower to ground.
- b. Stop engine, and remove key.



CAUTION

Stop engine, and remove key from ignition before leaving Operator's seat for any reason. A child or even a pet could engage an idling machine.

- c. Lift either end of the header "just" off the ground. Header flotation springs are normally set so 70 lbf (311 N) force is required to lift the header.
- d. Adjust springs as required. Refer to STEP 19. ADJUST FLOAT SPRINGS.

PRE-DELIVERY CHECKS

E. CONDITIONER ROLLS



WARNING

Stop tractor engine, and remove key before making adjustments to machine. A child or even a pet could engage the drive.

Lower header fully, stop engine, and remove key.

I. ROLL GAP

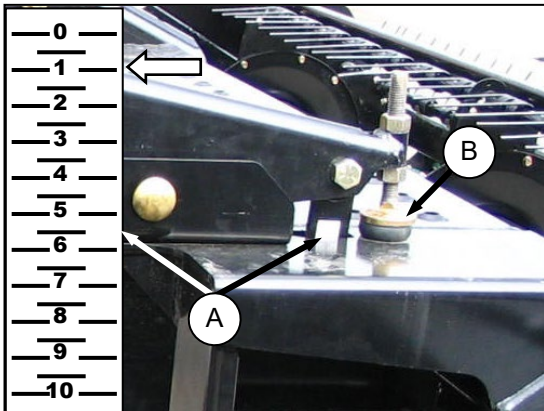
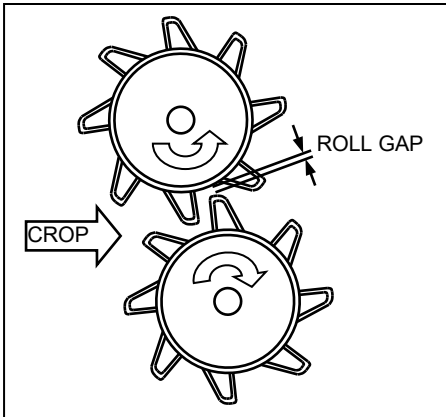

- Check **roll gap** is mark 1 on the decal (A).
- If required, adjust the stop (B).

NOTE

When adjusting roll gap, be sure that the decal reading is the same on both sides of the conditioner roll to achieve consistent intermesh across the rolls.

II. ROLL TIMING

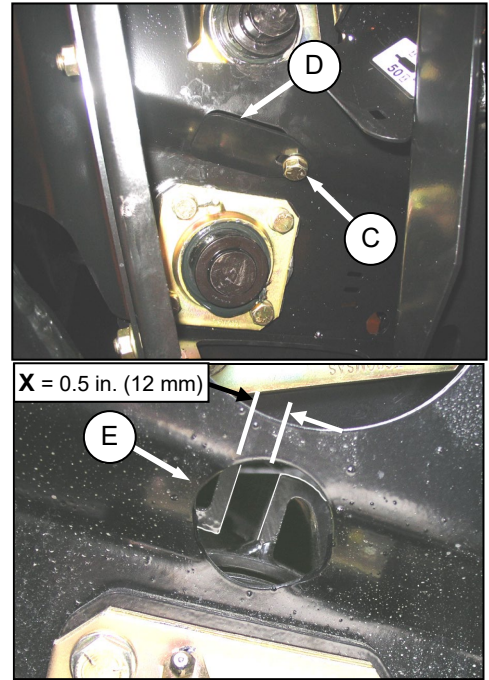

- Loosen bolt (C), and rotate cover (D) to expose access port (E) at each end of conditioner.
- Check **roll timing** by examining distance 'X' at each end of the rolls (E). Each steel bar on one roll should be centered between two bars of the other roll, so that distance 'X' is 0.5 in. (12 mm).
- If required, adjust the roll timing as follows:

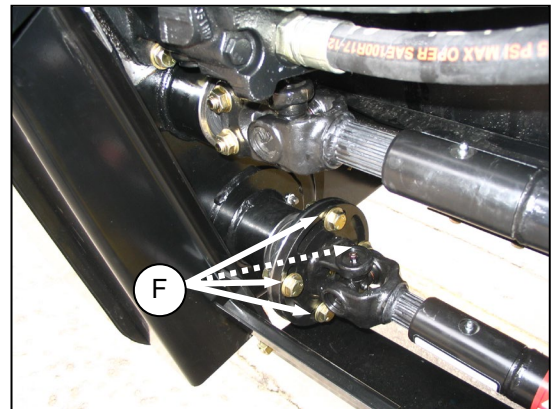

- Loosen four bolts (F) in slots of yoke plate on lower roll universal shaft.
- Turn rolls to achieve best timing.
- When roll timing is satisfactory, tighten bolts (F) to secure the position.
- Close cover (D), and tighten bolt (C).

PRE-DELIVERY CHECKS

F. SKID SHOES/GAUGE ROLLERS



WARNING

To avoid bodily injury or death from unexpected start-up or fall of raised machine, stop engine, remove key and engage lift cylinder lockout valves before going under machine to adjust skid shoes or for any reason.

- Raise header, and engage lift cylinder lockouts.

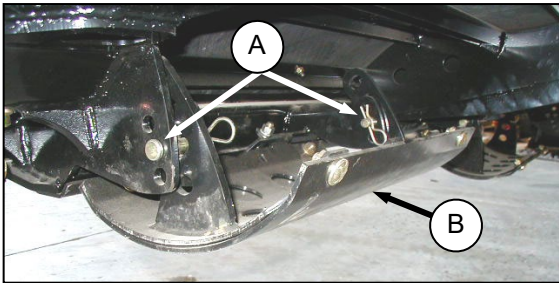

- Remove pins (A), raise or lower skid shoe/gauge roller (B) to desired position, and replace pins (A). Secure with hairpins.
- All shoes/rollers should be set at the same position.

G. LIGHTS

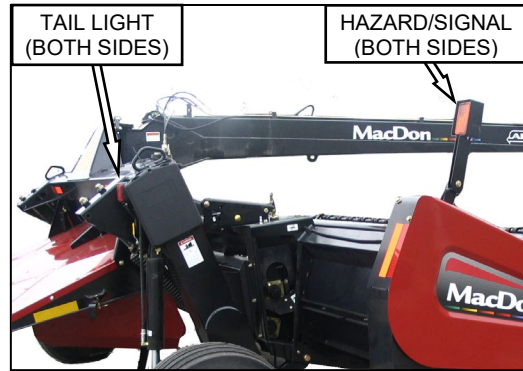

- The two amber hazard lights are mounted on both ends of the header, and are activated by switches in the tractor cab.
- The two red running and brake lights are mounted on the carrier frame, and are activated by a switch in the tractor cab, and by applying the brakes on the tractor.
- Check light mountings for security, and check lights for damage and for proper operation during run-up.

H. MANUALS

The following manuals should be stored in the manual storage case on the RH end of the carrier frame.



- A30-S and A30-D Pull-type Mower Conditioners, A30-S, A30-D, and A40-D Self-Propelled Windrower Headers PARTS CATALOG. See table below for manual number.
- A30-S and A30-D Pull-type Mower Conditioners, A30-S, A30-D, and A40-D Self-Propelled Auger Headers OPERATOR'S MANUAL. See table below for manual number.

HEADER	OPERATOR'S MANUAL NUMBER	PARTS CATALOG NUMBER
MacDon	169000	169002
Premier	169040	169073

PRE-DELIVERY CHECKS

I. RUN-UP THE MOWER CONDITIONER



CAUTION

- Never start or move the machine until you are sure all bystanders have cleared the area.
- Clear the area of other persons, pets etc. Keep children away from machinery. Walk around the machine to be sure no one is under, on or close to it.
- Before investigating an unusual sound or attempting to correct a problem, shut off engine, engage parking brake and remove key.



DANGER

Keep everyone several hundred feet away from your operation. Ensure bystanders are never in line with the front or rear of the machine. Stones or other foreign objects can be ejected from either end with force.



- a. Start tractor, and run the mower conditioner slowly for 5 minutes, watching and listening FROM THE TRACTOR for binding, interfering parts, or unusual noises.



CAUTION

Before investigating an unusual sound or attempting to correct a problem, shut off tractor, engage parking brake and remove key.

- b. Run machine at operating speed for 15 minutes, and perform the run-up check as listed on the "Pre-Delivery Checklist" (yellow sheet attached to this manual) to ensure machine is field-ready.

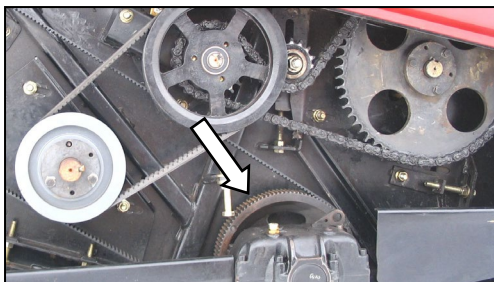

- c. Check actual speed of wobble box pulley speed using a hand-held optical tachometer during run-up. It should be 770 rpm. If not, check for pump and gearbox mis-match at front of APT.
- d. Retain the checklist and if desired, retain this instruction for future reference.

J. KNIFE

- a. Check guards for signs of heating during run-up due to insufficient clearance between guard and sickle.
- b. If heating is evident, proceed as follows:

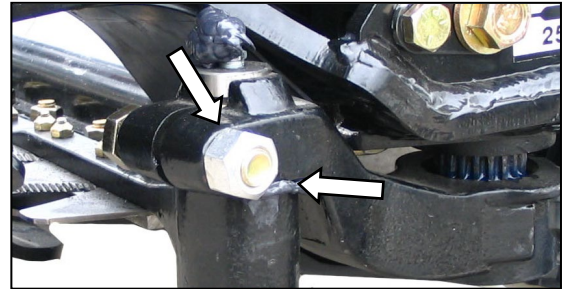

1. Check gap between knife head and pitman arm. A business card should slide easily through the gap. If not, then adjust gap by loosening bolt, and tapping knife head with a hammer. Re-tighten bolt.
2. Adjust guard alignment as follows: The guard straightening tool (MacDon #140135) is available from your MacDon Dealer:



UPWARD ADJUSTMENT

- i. Position tool as shown at and pull "up".



DOWNWARD ADJUSTMENT

- ii. Position tool as shown and push "down".

NOTES

NOTES

Pull-Type Mower Conditioner Model A30-S and A30-D Pre-Delivery Checklist

Perform these checks and adjustments prior to delivery to your Customer. See the Unloading and Assembly Instructions for details. The completed checklist should be retained either by the Operator or the Dealer.



CAUTION: Carefully follow the instructions given. Be alert for safety related messages which bring your attention to hazards and unsafe practices.

Windrower Serial Number: _____ APT Serial Number: _____

✓	ITEM	PAGE
	Check for shipping damage or missing parts. Be sure all shipping dunnage is removed.	---
	Check for loose hardware. Tighten to required torque if applicable.	5
	Check sickle drive belt tension.	44 - 45
	Check reel drive belt and chain tension.	44 - 45
	Check auger drive belt and chain tension.	44 - 45
	Check reel tine to header pan clearance.	46
	Check header angle to middle of adjustment range.	30
	Check header flotation - 70 lbf (311 N)).	46
	Check conditioner roll gap and timing.	47
	Check lean bar is adjusted at a setting appropriate for first crop.	31
	Check skid shoes are evenly adjusted at a setting appropriate for first crop.	48
	Check wobble box lube level and breather position.	31
	Check tire pressure - 30 psi (207 kPa).	---
	Check wheel bolt torque - 120 ft·lbf (160 N·m). If roading machine, re-torque wheel bolts after 1 hour.	12
	Check hydraulic oil level at sight gauge on side of APT.	16
	Check rear and side forming shields evenly set to desired position.	29
	Grease all bearings and drivelines.	35 - 43
	Check gearbox lube level.	40, 41
	Check roll intermesh hardware is securely tightened.	47
	Check hydraulic hose and wiring harness routing.	16
RUN-UP PROCEDURE		49
	Check hydraulic hose and wiring harness routing for clearance when raising or lowering header.	16
	Check speed of wobble box pulley - 770 rpm.	49
	Check running lights, amber hazard and signal lights are functional.	48
POST RUN-UP CHECKS. STOP ENGINE.		
	Check for hydraulic leaks.	---
	Check belt and chain drives for idler alignment and heated bearings.	44 - 45
	Check knife sections for discoloration caused by misalignment of components.	---
	Check auger stripper bar clearance.	46
	Check manuals in manual case.	48

Date Checked: _____

Checked by: _____

MacDon™

MacDon Industries Ltd.

680 Moray Street
Winnipeg, Manitoba
Canada R3J 3S3
t. (204) 885-5590
f. (204) 832-7749

MacDon Inc.

10708 N. Pomona Avenue
Kansas City, Missouri
United States, 64153-1924
t. (816) 891-7313
f. (816) 891-7323

MacDon Australia Pty. Ltd.

A.C.N. 079 393 721
P.O. Box 243
Suite 3, 143 Main Street
Greensborough, Victoria
Australia 3088
t. 03 9432 9982
f. 03 9432 9972

CUSTOMERS

www.macdon.com

DEALERS

www.macdondealers.com

Trademarks of products are the marks of their
respective manufacturers and/or distributors.

Printed in Canada